

www.spaceanimations.org

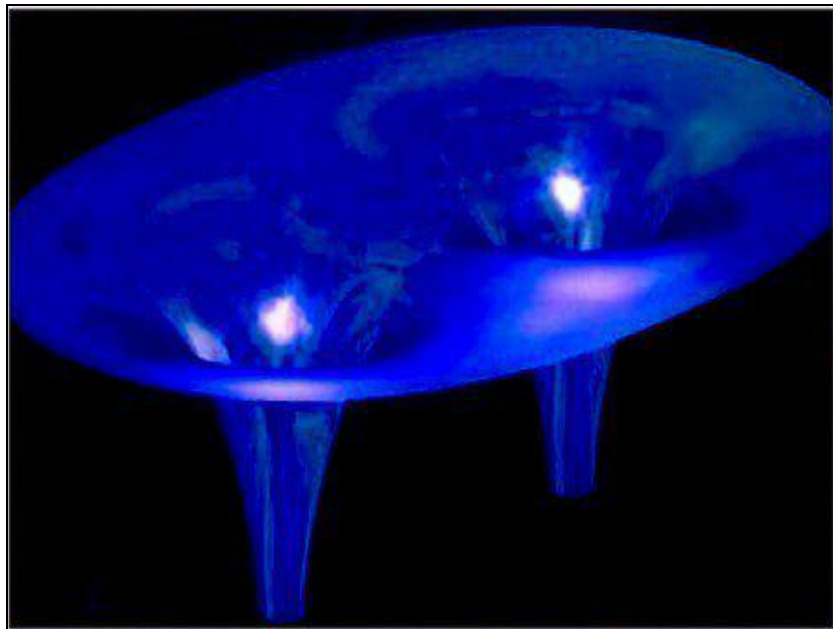

www.spaceanimations.org

VISUAL INSIGHTS TO SPACETIME AND GRAVITATION

Keith J. Mirenberg

INTRODUCTION TO GRAVITY-WELL MODELS OF CELESTIAL OBJECTS

AUTHORS PREFACE TO THIS SAMPLER

*This is a brief introduction to the book, "Beyond the Event Horizon: Gravity-Well Models of Celestial Objects". This short book is designed to familiarize the reader with the concept of the gravity-well, and to the effects of gravity on bodies in space. The larger book includes more detailed descriptions, formulas and insights for those more interested or advanced readers. The reader may obtain the full book when it becomes available. **Information will be posted at www.spaceanimations.org for obtaining the full book. One may contact the author with comments, as well as the current status of the developing full length book and for related research at keith314@optonline.net.***

The purpose of this e-book is to present the visual or **graphic** results of an ongoing interest I have had in the *gravity-well* model used by planetariums to demonstrate celestial motions. This model greatly assists in understanding the effects of gravity on orbital motions. It combines the products of my own research and learning experiences acquired over the years. This book attempts to explain the gravity-well model using intuition, illustrations, as well as examples from astronomy and Newtonian mechanics. The *full* length book, entitled "Gravity-Well Models of Celestial Objects", includes some 140 pages, where this sample e-book contains under 50. The *full* book includes many additional visual materials, numerically solved orbital mechanics problems and rules for scaling problems from actual space to the much smaller dimensions of the gravity-well model, as well as the supporting math.

Suggestions for reading this book:

The casual reader can review this material in any sequence, and depending on your interest in the physics was written to require no reference to the math. Any encountered during a first viewing may be skipped and later viewed at your discretion. On the other hand, some important technical details are provided in Appendix-A. The figures have been arranged in a topically logical order to promote understanding. Therefore, it is suggested that the text and illustrations simply be viewed in their order of appearance.

The motions of celestial objects were first set forth by Sir Isaac Newton in the **Principia** (*pronounced Prinkipia*): **The Mathematical Principles of Natural philosophy**. When first published the theory of motion of natural and artificial bodies was explained using this very simple and often cited drawing by Newton himself. This sketch illustrates how the flight of a cannon ball fired from a lofty mountain top with incrementally greater and greater velocity will either strike the Earth progressively further downrange, or given sufficient velocity, actually go into orbit around the Earth. Whether the trajectory strikes the ground, or continues in orbit, it is considered to be in "free fall". When in orbit, it never impacts the ground because the curve of the Earth falls away beneath the advance of the projectile. This was a very clever teaching tool for a then very new idea, and I will try to employ similar drawings to demonstrate how the gravity-well functions.

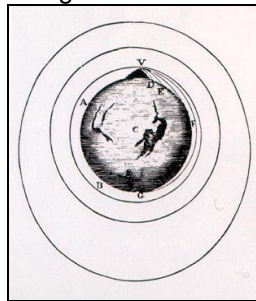

**Original Figure obtained from Newton's Principia:
The mathematical principles of natural philosophy**

Jumping from classic times to current times, the *gravity-well* has been popularized in recent years and those interested in astronomy may have noticed this visual tool presented during televised astronomy features as well as in beautifully animated science films dealing with gravity, general relativity, and black holes. Prior to their popularization, I witnessed my first model gravity-well in action in 1967 at New York's original Hayden Planetarium. Although I had noticed this concept used in illustrations for various science books, I had never seen a *working* model of gravity, or the movements of rolling steel balls used to represent the orbital motion of satellites.

INTRODUCTION TO GRAVITY-WELL MODELS OF CELESTIAL OBJECTS

The well fascinated and intrigued me, and its very beautiful and sensible shape enabled me to anticipate many of the effects of gravity fields before my training covered these subjects in formal courses in orbital mechanics. For the benefit of those readers not familiar with the subject, the gravity-well is a surface of revolution formed by rotating a suitably shaped curve around a central vertical axis, sweeping out an axisymmetric surface resembling the bell mouth of a horn. As illustrated by the following figure the motions of a rolling ball on the well resemble those of a satellite of the Earth or planet of the Sun. It also provides the ability to play out orbits in a lab setting or planetarium which could otherwise only be experienced very slowly using a pencil, paper and calculator, more rapidly on a digital computer, or physically in orbit. In a real sense, the gravity-well provides a defacto analogue computer for orbital mechanics. In any case, a quick Google search on the World Wide Web will demonstrate the current use of this model in planetariums and other educational settings.

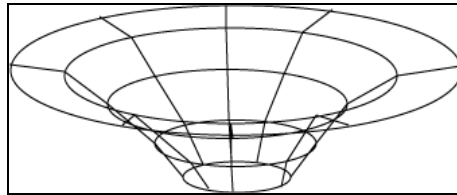

www.nasa.gov

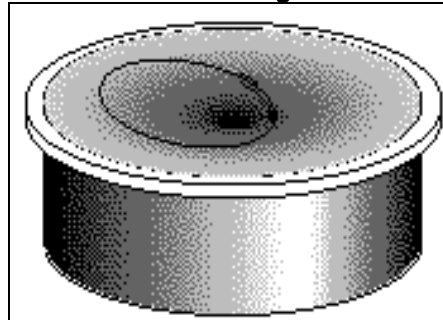

www.nasa.gov



Gravity-well Exhibit at Boston Museum of Science-Photo taken by author ~1980

Just a note that the *majority* of the computer graphics contained herein were, for better or worse, created using my original graphics and orbital mechanics programs written in Fortran, Basic, Excel or otherwise developed in a commercial CAD system. These drawings reflect my long term obsession with the gravity-well as an object of great interest, utility and graphic beauty. The above two public domain figures are credited to NASA's web site, www.nasa.gov. There are also some excellent materials on Wikipedia, the free encyclopedia.

TABLE OF CONTENTS TO THIS SAMPLER

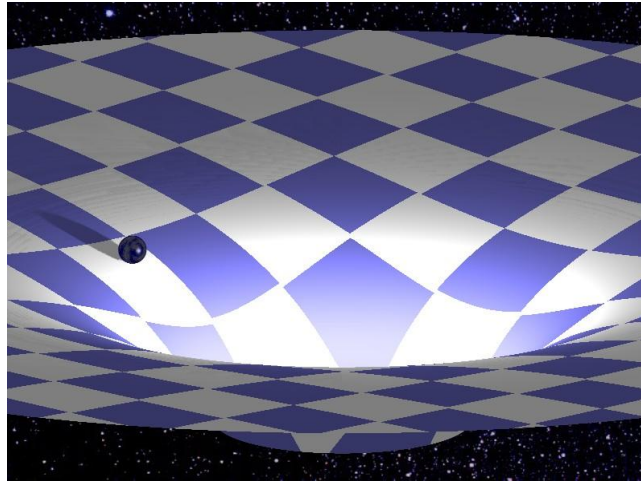

Figure-1 Body Orbiting within a Gravity-well – www.spaceanimations.org

1.0	<u>INTRODUCTION</u>	6
2.0	<u>WHAT IS A GRAVITY-WELL AND HOW TO INTERPRET IT?</u>	
2.1	Potential Energy in a Gravitational Field	8
2.2	Civil Engineering's Banking Formula and the Gravity-Well	12
2.3	Graphic Development of the Gravity-well Shape	13
3.0	<u>ORBITAL MECHANICS AND A HISTORY OF THE LAWS OF MOTION</u>	17
3.1	Galileo's Inclined Plane Experiments for Projectile Motion	17
3.2	Kepler's Three Laws of Planetary Motion	20
3.3	Newton's Three Laws, Universal Law of Gravitation, and Planetary Motion	22
3.4	Einstein's Laws of Gravitation and Spacetime Curvature	23
4.0	<u>BASIC ORBITAL MOTION AND THE GRAVITY-WELL</u>	25
4.1	Circular Orbits	27
4.2	Elliptical Orbits	28
4.3	Parabolic Orbits	28
4.4	Hyperbolic Orbits	29
4.5	Comments on Motions Observed on Gravity-Well Models	30
5.0	<u>CONCLUDING REMARKS</u>	
5.1	The Commerce of Gravity-Wells	
5.2	My final thoughts	
6.0	<u>REFERENCES, BOOKS, & SUGGESTED READING MATERIALS</u>	
7.0	<u>Popular Articles, Technical Papers, and Web Papers</u>	

INTRODUCTION TO GRAVITY-WELL MODELS OF CELESTIAL OBJECTS

Appendices:

- A: Gravity Analogue, Keith J. Mirenberg, SPECTRA, THE STUDENT PUBLICATION OF THE COLLEGE OF SCIENCE AND ENGINEERING AT FDU, TEANECK, NEW JERSEY, VOLUME 4, NO. 2, APRIL 1968**

- B: Examples of orbital computer graphics automatically generated by the "TIME-HIST" Orbital Prediction Code, Program written in Basic for Microsoft DOS – by Keith Mirenberg of WWW.SPACEANIMATIONS.ORG**

- C: Friction and the Influence of Spin and Inertia on Gravity-Well Motions
1) Insights on the Longevity and Fidelity of Orbits on the Gravity-Well**

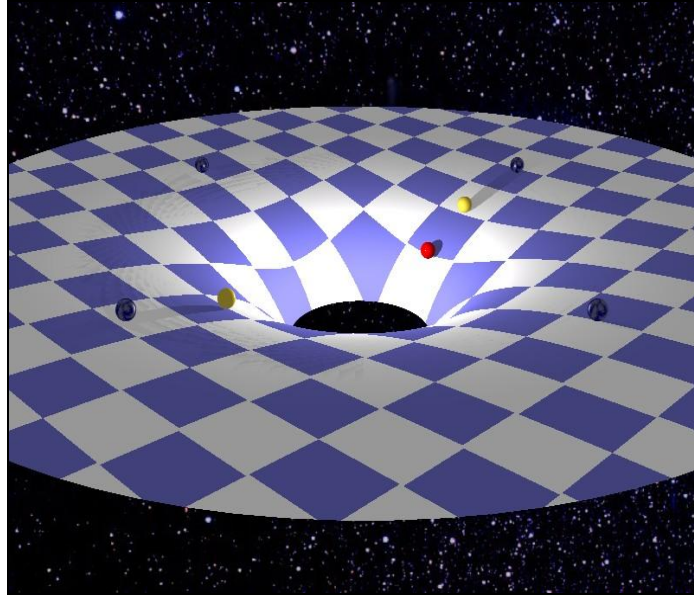

Figure-2 Graphic Interpretation of Orbiting Planets and Central Sun-
www.spaceanimations.org

1.0 INTRODUCTION

It was as a young and impressionable engineering student that way back in 1967 I had my first look at a working *gravity-well* model while visiting the original Hayden Planetarium in New York City. The older Hayden (replaced by its currently beautiful but glitzy counterpart) was a wonderfully atmospheric and moody place, filled with the darkness of space and a veritable maze of fascinating exhibits. As I walked through the silence and rounded a corner, I suddenly heard the impact and rolling sound of a pinball machine, so out of place in this setting. Walking ahead in the darkness I found that a new exhibit had been added to the Hayden. The exhibit caught my attention running itself endlessly while repeatedly demonstrating planet and comet like motions. It was roughly five feet in diameter and then appeared very similar to the exhibit shown below, which was photographed some years later at the Boston Museum of Science by the author.



Figure-3 Photo of a Gravity-Well Model
with permission of the Boston Museum of Science

INTRODUCTION TO GRAVITY-WELL MODELS OF CELESTIAL OBJECTS

Just as glad to be alone on this first viewing occasion, I lingered for a moment watching this new device operate. It appeared to have a life of its own and sounded with the *regularity* of a cosmic clock and the *urgency* of a celestial pinball machine, as several steel balls were dispensed to demonstrate their orbit like motions. So much so that the softer white well surface beneath the moving balls was starting to wear from the cumulative effects of friction with the hard steel ball bearings. As shown on the bottom of page 11, the visible wear on the well surface formed an elliptical trace and caught my attention. Realizing that I had read about this visual aid before in books by then popular science writers like Arthur C. Clarke, I had never heard it suggested that an actual surface could be constructed to form an analogue of gravity. At the time I wondered what equations were used to produce this surface and what physics it was based on. The problem instantly caught my interest and without realizing it, I took this problem home to think about, indeed intermittently for the rest of my life. I thought about it for a while obsessively, and then returned to the business of an engineering student, homework and school.

Shortly after this we student engineers were introduced to an equation used in civil engineering called the banking formula. This equation is employed to determine the radial slope of a banked roadway required to prevent cars and trains from spiraling out of control while making rapid bends and comfortably maneuvering turns at a given speed and radius. When a roadway is properly banked for specific speeds an occupant will “feel” little or no outward centrifugal force during the turn. After mentally playing with this convenient formula I suddenly remembered the planetarium gravity-well problem, and realized that I could use this relationship to determine the banking slope angle and ultimately the formula of the gravity-well surface.

I applied the banking formula to a gravity-well having approximately the same size as the working model I saw at the Hayden. I assumed a scaled value of orbital velocity for the ball based on circular orbits around the Earth. I assumed that the ball possessed the exact velocity required to maintain a circular orbit at every radius on the well and the local slope of the well surface required beneath it. This step provided me the radial slope of the gravity-well at every radius along the surface. I was then able to determine the height of the well at each radius by using calculus and what is called a single integration. At this point the only remaining task was confirming the equation by contacting the Hayden Planetarium in writing. After drafting a letter to the curator I received verification of the formulae. I also received some free advice concerning the practical construction of a working gravity-well model from the Hayden. Engineering school continued, and while studying more down to Earth topics in mechanical engineering I kept the gravity-well model in the back of my mind for future development. I realized that the gravity-well could be used to explain many effects in orbital mechanics. This book is the result of that focus while studying subjects in physics and the motions of bodies in a gravity field.

The gravity-well applies to: planet like near circular and elliptical orbits, as well as comet like parabolic and hyperbolic orbits. It is also applicable to pure radial motions. In addition, noteworthy velocities known as **escape**, **excess** and **residual velocity** can all be explained and demonstrated on the well, as well as several effects hinted at in the table of contents. As will be explained, **escape velocity** is the minimum speed required to escape the gravity-well, **excess velocity** is the amount by which local velocity exceeds escape and **residual velocity** is the theoretical velocity remaining with the object after traveling an “infinite” or very great distance from a gravitating body.

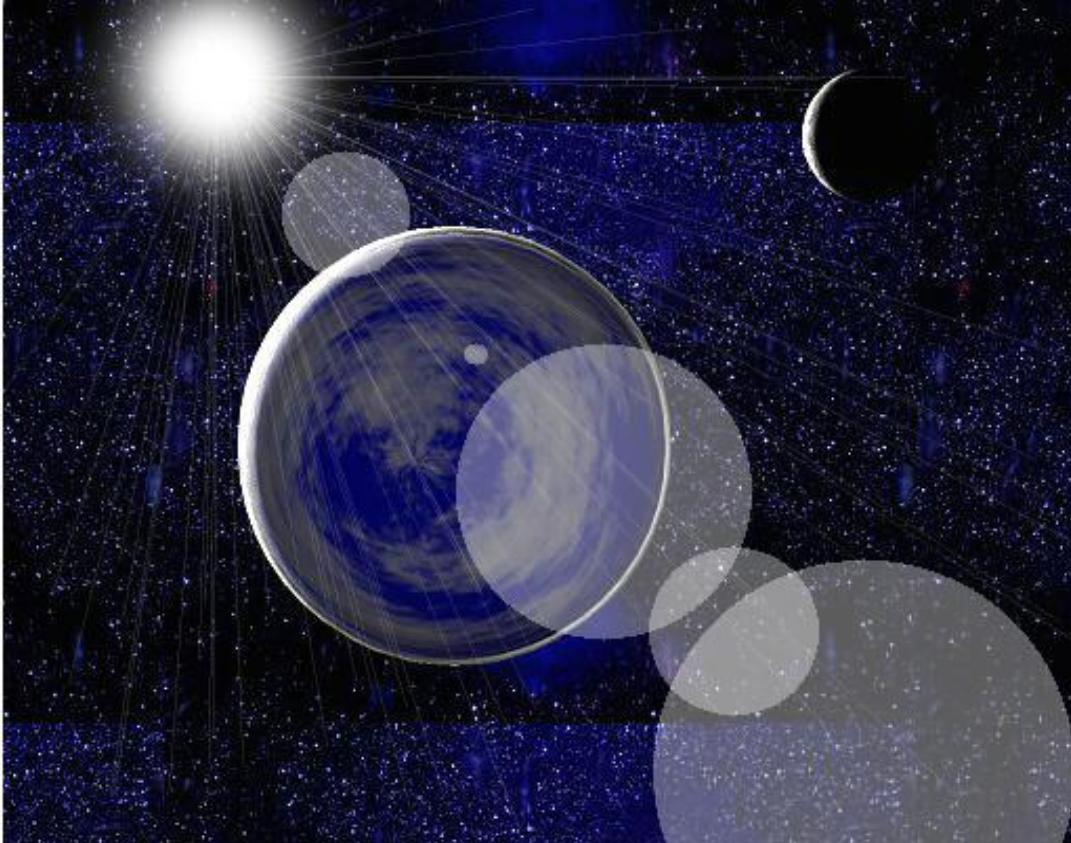

Figure-4 The Earth-Moon System in Space - www.spaceanimations.org

2. WHAT IS A GRAVITY-WELL AND HOW TO INTERPRET IT?

2.1 Potential Energy in a Gravitational Field

A gravity-well model of the Sun visually represents the *gravitational potential energy* in what is called the solar systems Newtonian inverse square force field. This is derived using basic dynamics to define the equation and plotted shape below. This equation is also called a $1/R$ *potential function*, and as was done in Appendix-A, was developed using Newton's law of gravity, his second law of motion and the banking formula, producing the equation for gravitational potential energy and the shape of the gravity-well which is: $Z = -Cs / R$.

As illustrated in Figure-5 below, the greater the radial distance R and the further out the ball from the well center, the greater the elevation of the ball and its gravitational potential energy. Potential energy can be exchanged for velocity and associated kinetic energy of motion, as when in an actual orbit. A ball released from rest accelerates along the well surface by rolling downward and inward towards the well center. Also, as will be discussed, an initially rolling ball having a velocity which carries it **around** the well center will move in a similar manner to an object in orbit and subject to the gravity field of the star or planet modeled to be at the center of the well.

INTRODUCTION TO GRAVITY-WELL MODELS OF CELESTIAL OBJECTS

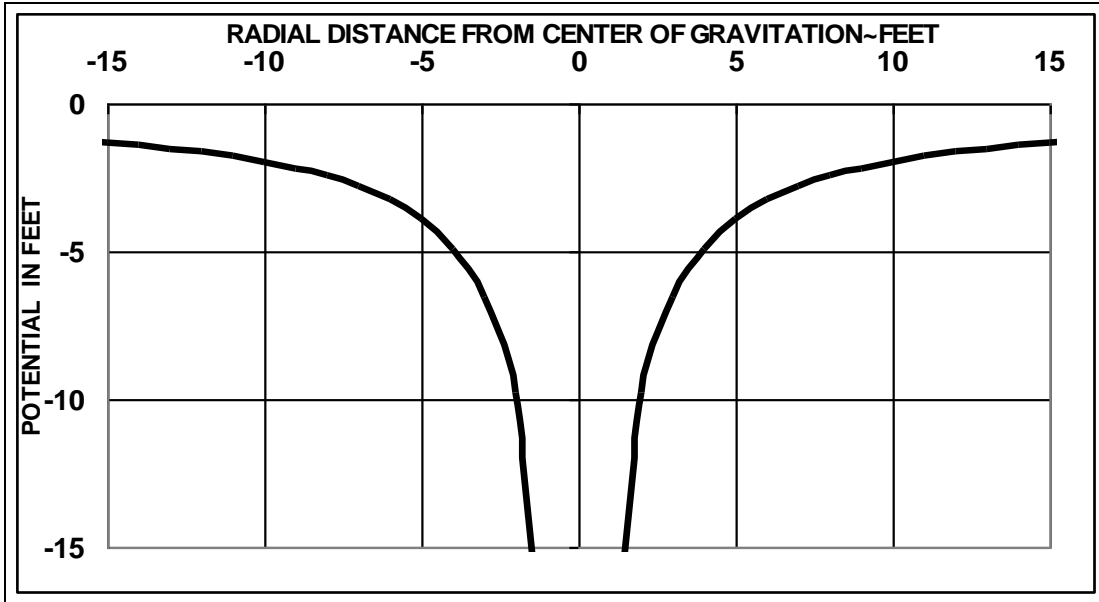

Figure – 5 ELEVATION OR POTENTIAL OF GRAVITY-WELL PRODUCED BY SINGLE BODY

The gravitational potential energy of an object like a metal sphere, or rolling ball bearing, can be computed *in the laboratory* as the weight of the sphere in pounds *multiplied* by its height in feet, relative to some *arbitrary elevation level* established in the lab for the well. **Gravitational potential** can be thought of as the potential energy per unit weight, or a simple *elevation* measured in feet, Z. Analogously, this is called *the elevation head* in fluid mechanics, and in Bernoulli's equation along a streamline.

$$\text{Potential: } V = [\text{PE} / W] = [\text{Weight} \times \text{Height}] / \text{Weight} = \text{Height } Z$$

It is possible to establish the “zero” of potential energy at any location along the sloping surface of a gravity-well. However, it is often located at the maximum height of the theoretical *flat* summit at the highest point of the gravity-well, as is conventionally done for solar or planetary potential energy. The most radially distant location and the top of the gravity-well is an especially convenient reference point where the height and potential energy are a *maximum* and become increasingly negative (i.e., smaller) as the distance R decreases from infinity to zero. There is no contradiction in saying the potential energy is **zero** at an infinite distance and **maximum** at the same place, since at every other location the potential energy is *negative* and is indeed *numerically smaller*.

It can be said without qualification that the gravity-well provides an excellent model of **gravitational potential energy** in the Newtonian “inverse square” gravity field. Newton's law of gravity is provided below for completeness, where M and m are the masses of the planet and satellite, R is the distance between their mass centers, and G is Newton's universal constant of gravity which was observationally approximated and then more precisely determined by numerous laboratory tests many years ago.

$$F = (GM \times m) / R^2$$

The equation of Newton's law of gravity states that the gravitational force varies *directly* as the product of the mass of the planet and the body, and *inversely* as the square of the distance between the mass centers of the planet and body.

INTRODUCTION TO GRAVITY-WELL MODELS OF CELESTIAL OBJECTS

Note that Newton's law of gravity has stood *the test of time** and is used to predict the paths of satellites in Earth orbit, the trajectories of vehicles to the Moon, and those of our deepest space probes on their way to the outer planets and interstellar space. While it is possible to derive the shape of the gravity-well starting with the equation for Newton's law of gravity, (as has been done in Appendix-A), we will pause here and step through the development of the gravity-well *graphically* by employing the next few figures to familiarize the reader with the general shape of the gravity-well. Also, these figures illustrate some convenient coordinate systems in which to develop the equation of the well. Optional review of Appendix-A is suggested for those who may be interested in the mathematics.

Those readers interested in physical analogies may appreciate the reference made by Willey Ley (in Reference 5, Satellites, Rockets and Outer Space), to the motions of space vehicles in the *nested* and moving gravitational *whirlpools of the planets contained in the single and much larger gravitational whirlpool of the Sun*. This model can be used to help visualize the movements of space vehicles within and between the various gravity fields of the solar system. Although Mr. Ley did not specifically mention the "gravity-well", there is little doubt that his reference was to the vortex shaped "gravity-well". The multiple vortex analogy of Mr. Ley can be used to illustrate the motions of space vehicles as they exit the smaller gravity field of a planet and enter the much larger and *much* more pervasive solar gravity-well to become an artificial planet of the Sun. **The reader is invited to see "Gravity-Well Models of Celestial Objects" for additional details.**

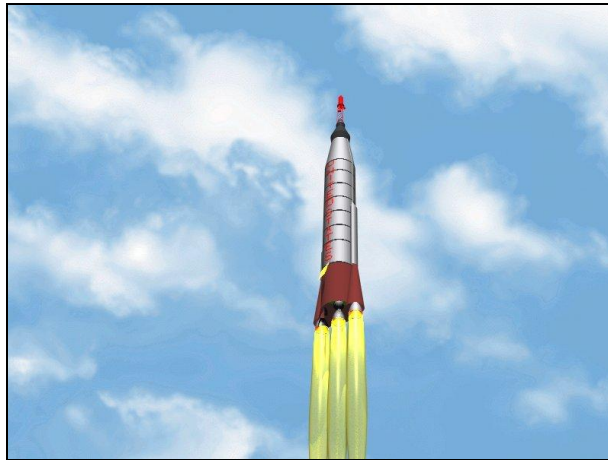

An Atlas Mercury Launch – www.spaceanimations.org

* Note that the only corrections which have been made to Newton's law of gravity is for extremely distant deep space probes, attempting to explain the small differences which have accumulated in their long term trajectories after many years. We are referring specifically to the Pioneer missions which were both ejected from our solar system by the strong gravity field of Jupiter and entered interstellar space many years ago. These corrections included Einstein's General Theory of Relativity which alone can't explain the cumulative differences between our best predictions and observations. These adjustments included other various and more speculative ad hoc corrections ranging from modifications to Einstein's gravity model, to perturbations due to solar wind, clouds of space dust, and spacecraft out gassing of materials. The mystery of the small anomalous motions of Pioneer X and XI is called the Pioneer-X anomaly and is a subject of professional debate by NASA and other space scientists, and publication on the World Wide Web (See referenced technical papers 1 and 2).

INTRODUCTION TO GRAVITY-WELL MODELS OF CELESTIAL OBJECTS



**Author's Photo of Gravity-Well Model taken and published with
Permission of the Boston Museum of Science & Planetarium-1980**

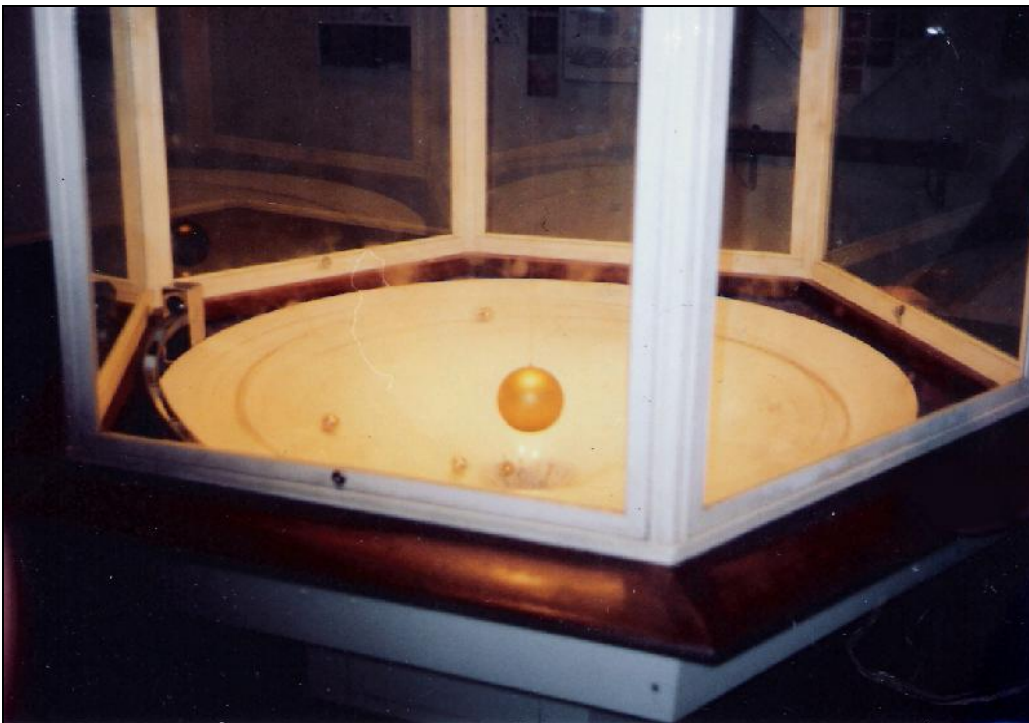

**Gravity-Well at the Hayden Planetarium by Keith Mirenberg 1967
Courtesy American Museum of Natural History**

Notice the elliptical wear trace on the well surface due to the rolling friction of the balls.

INTRODUCTION TO GRAVITY-WELL MODELS OF CELESTIAL OBJECTS

2.2 Civil Engineering's Banking Formula is Related to the Gravity-Well.

The banking formula and Newton's second law of motion ($\Sigma F=ma$) are used to develop the equation of the radial slope of the gravity-well. Illustrated below is a section of roadbed having a radius R and banked at the angle φ and also an object representing a vehicle moving along the banked turn with circular velocity V .

The banking formula is:

$$\tan(\varphi) = V^2 / (R \times g)$$

Where: φ = the slope angle (see figure below)
 R = the radial location of vehicle in feet
 g = gravitational constant (32.2 ft/sec²)
 V = velocity for a banked turn (in ft/sec)
 in "pseudo-equilibrium" (see below)

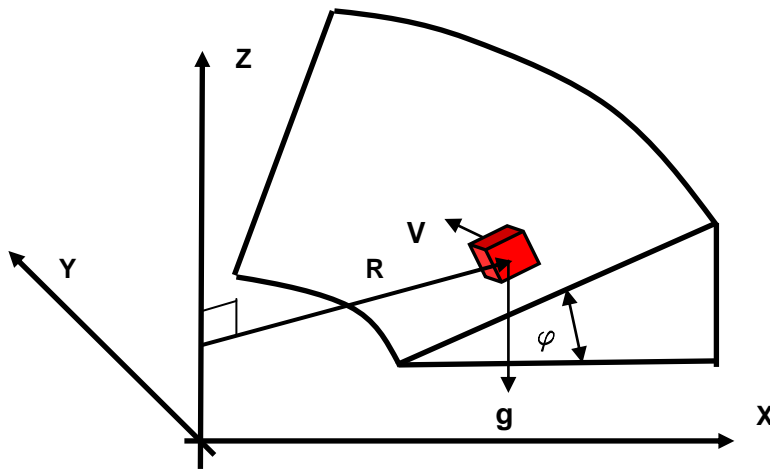

Figure – 6 BANKED ROAD BED IN CONVENIENT X, Y, Z COORDINATE SYSTEM

The radial slope angle φ , constant radius R , and local velocity V provide a condition of dynamic equilibrium (or pseudo-equilibrium), and in the case of a powered vehicle (i.e., car, truck, train, etc.) will maintain a circular path parallel to the horizontal (X-Y) plane. The reason this condition is termed "pseudo-equilibrium" is that the vehicle is in actuality experiencing centripetal (or center seeking) acceleration, $a_c = V^2/R$.

If we replace the vehicle with a rolling ball placed at a radius R and intend for its motions to mimic the effect of gravity and travel in a circular orbit on the surface it must travel with velocity V which varies as the *square root of 1/R*, as in planetary motion. In other words, the smaller R and the *closer* the ball is to the center of the well the *greater* the velocity V required to maintain a circular orbit. Conversely, the greater R and the more distant the ball is from the well center the smaller the velocity V needed for a circular orbit.

* Note that circular orbital velocity of the Earth is $V_c = \sqrt{GM_e / R_e}$

INTRODUCTION TO GRAVITY-WELL MODELS OF CELESTIAL OBJECTS

The tangent of the radial slope angle φ must be set equal to the ratio of the centripetal acceleration $\mathbf{a}_c = \mathbf{V}^2/\mathbf{R}$, to the acceleration of gravity \mathbf{g} ($\sim 32.2 \text{ ft/sec}^2$), producing the banking formula. This formula can be used to represent the radial slope of a gravity-well for circular orbits having velocity \mathbf{V} and radius \mathbf{R} . The radial slope is the $\mathbf{Tan}(\varphi)$, or the value of the “rise over the radial run” of the surface, (i.e., $d\mathbf{Z}/d\mathbf{R} \sim \Delta\mathbf{Z}/\Delta\mathbf{R}$).

$$\mathbf{Tan}(\varphi) = (\mathbf{a}_c) / \mathbf{g} = (\mathbf{V}^2/\mathbf{R}) / \mathbf{g} = \mathbf{V}^2 / (\mathbf{R} \mathbf{g})$$

2.3 Graphical Development of the Gravity-Well Shape

In Figure – 7 below the coordinate system is one in which the equation of the surface of revolution defining a gravity-well can be readily developed. The radial distance \mathbf{R} is the shortest straight line between the well central axis \mathbf{Z} and the ball. In other words, it is the distance between the well center and the orbiting object measured perpendicular to the axis \mathbf{Z} . It is this shortest distance \mathbf{R} which is analogous to the distance between a gravitating Sun and its planet, or planet and its orbiting satellite.

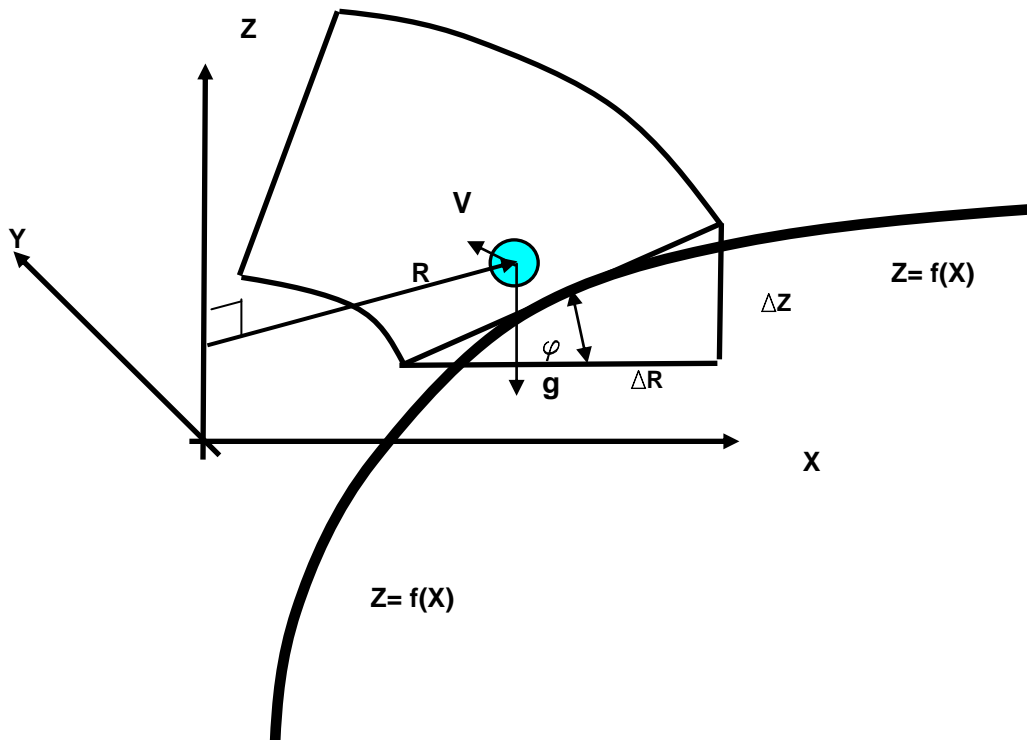

Figure – 7 BANKED ROADBED IN X, Y, Z COORDINATE SYSTEM, INCLUDING $Z=f(X)$

The equation of the well projected into the front $\mathbf{X} - \mathbf{Z}$ plane will be called $\mathbf{Z} = \mathbf{f}(\mathbf{X})$ or “ \mathbf{Z} of \mathbf{X} ” which stands for the elevation \mathbf{Z} of the surface as a function of \mathbf{X} . This curve when rotated around the vertical \mathbf{Z} axis will define the surface of revolution as shown in Figure – 8.

INTRODUCTION TO GRAVITY-WELL MODELS OF CELESTIAL OBJECTS

In Figure – 8 below we show the partially developed gravity-well by illustrating that portion of the surface produced by 90 degrees rotation of the curve $Z=f(X)$ around the vertical Z axis. Since we are developing an axisymmetric surface, or surface of revolution, the function $Z=f(X)$ has the same shape as $Z=f(Y)$ or any curve for the surface in the radial direction, $Z=f(R)$. Intuitively, this axisymmetric shape mimics the effects of gravity.

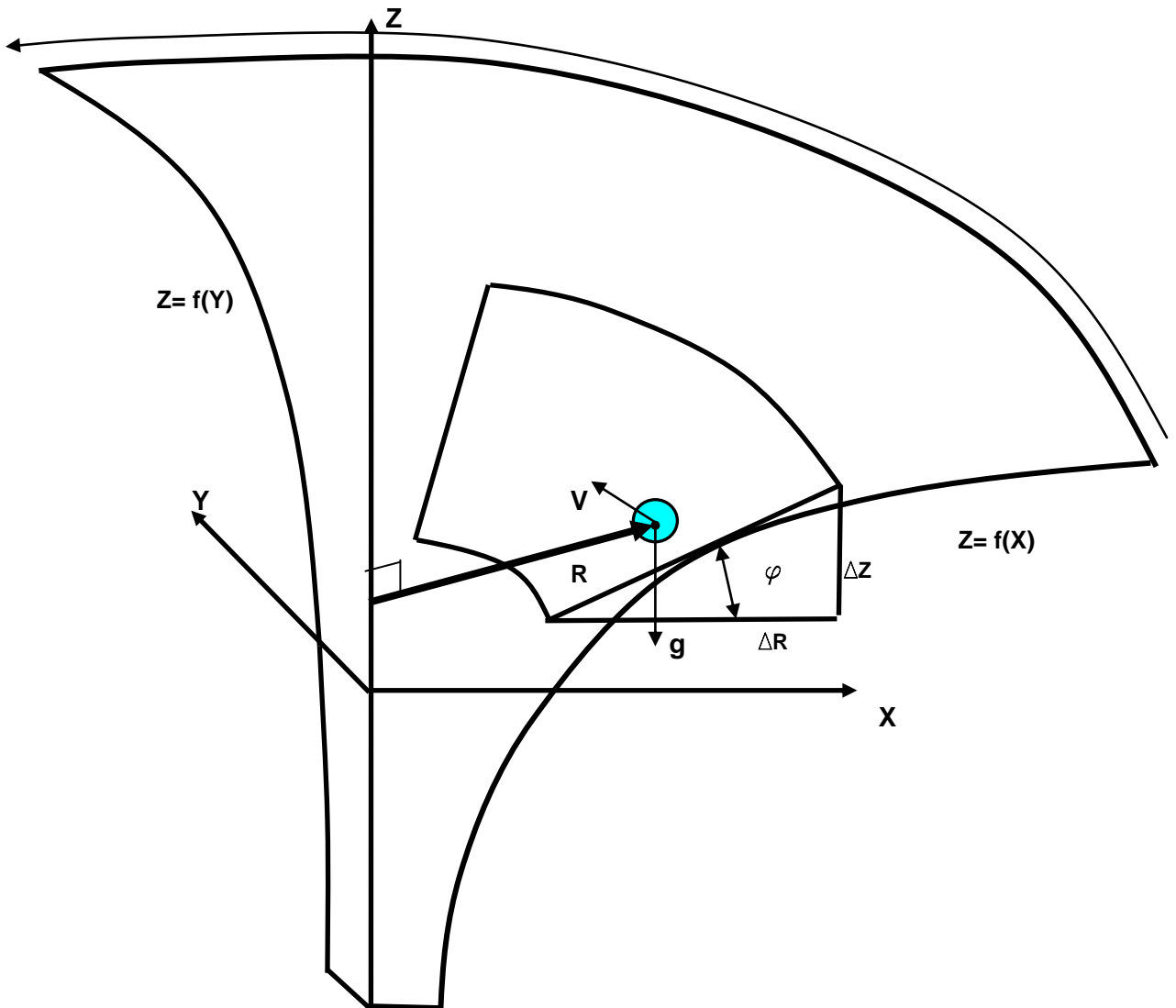

Figure – 8 SURFACE GENERATED BY THE FIRST 90 DEGREE ROTATION OF $Z=f(X)$ ABOUT Z -AXIS

Since the above figure is a bit cluttered by the remnants of the banked roadbed, we will remove the road from the figure and instead insert all the labels associated with the instantaneous coordinates (i.e., lower case x , y and z) of the rolling ball.

INTRODUCTION TO GRAVITY-WELL MODELS OF CELESTIAL OBJECTS

As shown in Figure 9 we again illustrate the partial surface generated by the first 90 degrees of rotation around the Z-Axis. Figure 9 contains pure geometry. Note that the radius r is defined as the distance between the origin of the system (i.e., the intersection of the X, Y and Z axes) and the location of the ball (or the surface immediately below the ball), while R represents that distance projected into a horizontal plane passing through the ball. The location of the ball is indicated as lower case letters x , y and z .

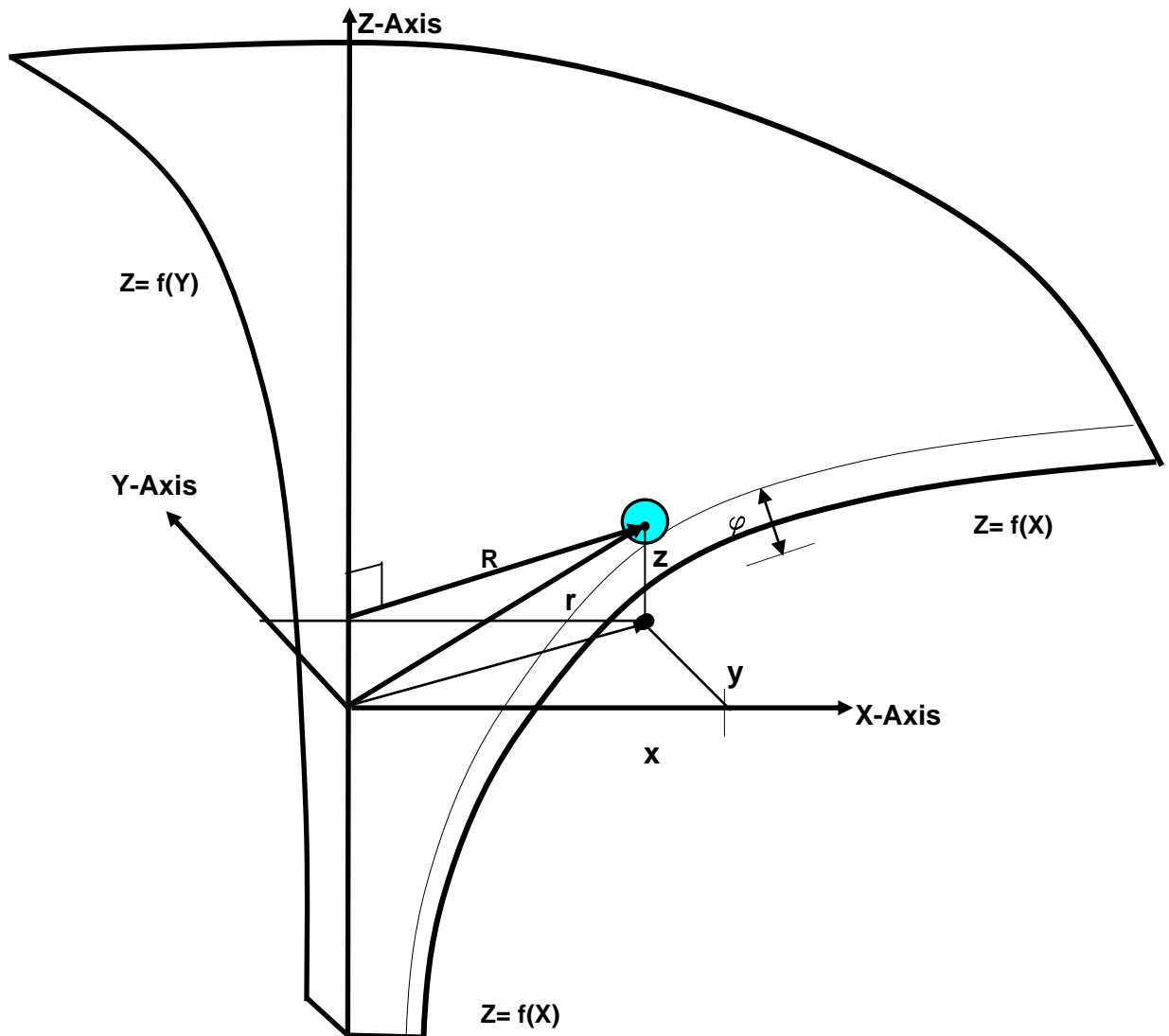

Figure-9 SURFACE GENERATED BY FIRST 90 DEGREE ROTATION AROUND Z-AXIS

The equation for the gravity-well is presented immediately below and has been sketched in Figure 10. This figure illustrates a fully developed gravity-well in its space.

$$Z = -C_s / R$$

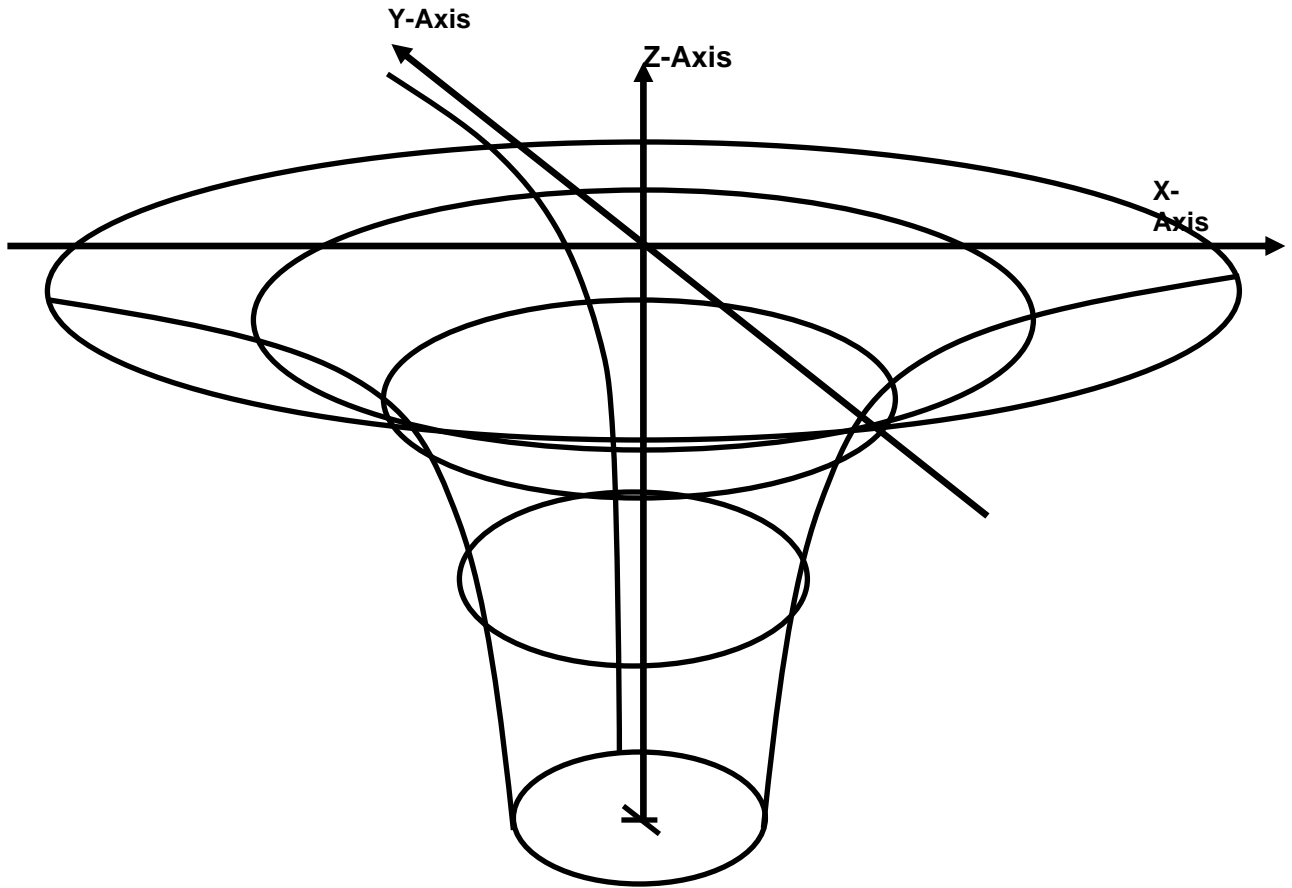

Figure-10 WIRE FRAME MODEL OF FULLY DEVELOPED GRAVITY-WELL

The above equation, whose curve must be rotated around the central Z-axis to generate the surface of revolution of the gravity-well, is that of a simple hyperbola, $x^2 = cz$.

The derivation of the working formula for the gravity-well surface is contained in Appendix-A. Note that within Appendix-A, the x, y and z coordinate system has been employed with a vertically oriented Y-Axis. Therefore, both the X and Z-Axes and the X-Z plane lie within the horizontal. This appendix, which was originally written in 1968, contains the following topics: 1) Kepler's three laws, 2) Newton's work to derive them, 3) quantities which must be preserved by a gravity-well, 4) sample scale factors for distance and velocity calculated for a sample "gravity-well". Also discussed are: 5) interference with modeling accuracy due to surface friction and air windage of a rolling ball, 6) partial reduction of surface resistance with the use of a low friction surfacing material called Teflon, 7) the role of the moment of inertia of a solid sphere on the total kinetic energy of the ball when rolling without slippage, 8) the probable further reduction of the effect of surface friction and windage by substituting a low profile air puck for the ball. Also, the possible interference with the air puck film "surface effect" due to excessive well curvature. The reader is invited to see "Gravity-Well Models of Celestial Objects" for additional details.

3. ORBITAL MECHANICS AND A SHORT HISTORY OF THE LAWS OF MOTION



Figure-11 Early Spiritual Places and Temples were likely Observatories having Celestial Alignments with the Sun, Moon and Stars - www.spaceanimations.org

It is very likely that the earliest people to observe the sky and ascribe meaning to what they saw were the wise shamans and priests of their community. These persons produced the mythical origins, assigned names and perhaps imaginative stories to our great constellations and the important activities of seasonal hunting, gathering, planting and harvesting, indeed human survival benefited.

Then first starting with simple mounds of earth, circles of wood and piles of crude stone, proto-temples were built. These eventually evolved into the construction of grand temples all over the world. The Aztecs, Babylonians, Chinese, Egyptians, Incans and Mayans were among the earliest astrologers and astronomers. These peoples fashioned the beautiful stone and plaster temples of the Americas, Asia, Babylon, Egypt, and the Arab world which are believed to have featured numerous celestial alignments. These structures permitted a record to be made of the periodic motions of the heavens, and the sudden appearance of noteworthy celestial objects to be kept against their fine stonework.

It is these records of the time and place of celestial events and general sky movements which enabled much later people to begin the development of the rules governing the movements of sky objects and ultimately the laws of celestial motions and orbital mechanics. A short history of these laws is next discussed.

INTRODUCTION TO GRAVITY-WELL MODELS OF CELESTIAL OBJECTS

It can be said that the development of the accepted laws of orbital mechanics began in the 17th century with the work of Johannes Kepler (1571 – 1630). Kepler was a mathematician and apprenticed to the great astronomer Tycho Brahe who had recorded the precise motions of the planet Mars. Kepler accepted the problem of explaining the motions of Mars as recorded by his teacher. Starting with nothing more than good intentions and Tycho's excellent data, and after searching in the dark for 20 years, Kepler arrived at his three laws of planetary motion still taught at universities today. Since these laws were formulated without the aid of any physical theory, Kepler's approach can be described as empirical requiring trial and error, and at times resorting to mystical numerology and notions of numerical and natural beauty. However, some years later when Newton was able to derive Kepler's laws by assuming an inverse square law for planetary attractive force, the Newtonian theory scored a major victory.

3.1 Galileo's Inclined Plane Experiments for Projectile Motion

The refinements of the laws of motion owe a debt to many people, but none more than the great Galileo Galilei (1564 – 1642). In addition to other ingenious means, Galileo was able to employ inclined tracks and planes to slow down and study the motions of falling (or rolling) objects in his lab. In this way he could time the distance they covered against the semi-regular beat of his heart or water clock. This approach is similar to using a gravity-well model where the radial slope of the well is restricted to a *constant* value of gravity acting near the surface of the Earth. It was by these means that Galileo learned that the distances covered by a falling (or rolling) object increases as the square of the time of travel (**Dist = [1/2] x A x t²**), known as the Law of Squares. He was thus able to study rectilinear motion along a straight line and reach useful conclusions regarding motion.

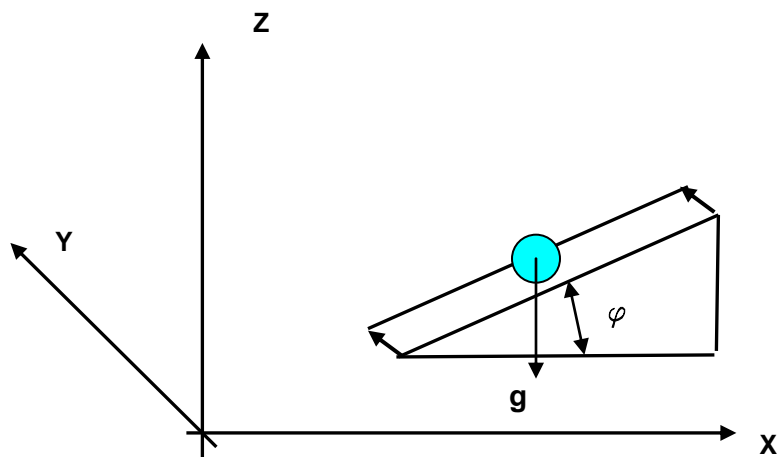

If Galileo extended his sloping flat plane into the third dimension (Y above) he would have been able to reproduce projectile or near parabolic motion. The reader can also see the similarity of the figure below and rotating a suitable curve around the Z axis to produce a true gravity-well, the illustration of which is provided in Figure-10 and below.

INTRODUCTION TO GRAVITY-WELL MODELS OF CELESTIAL OBJECTS

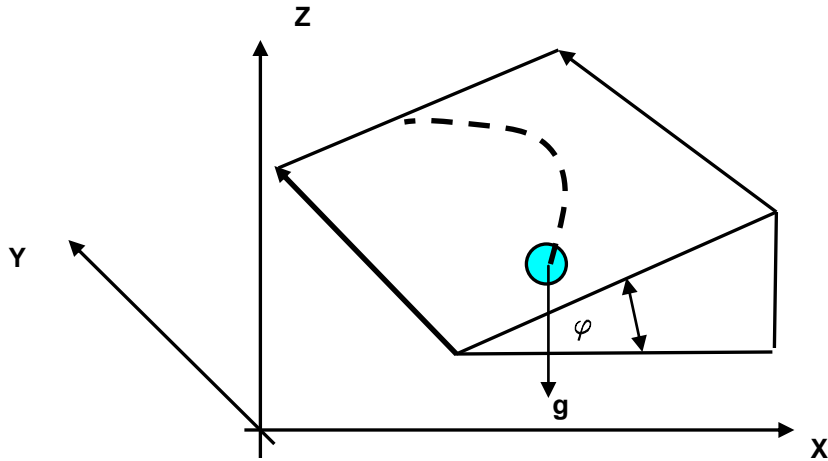

In a real sense Galileo's inclined plane depicted above represents the uniform gravity field existing over a relatively small distance along the Earth's surface, or over a flat Earth. In addition, the climb of the projectile over the Earth must be modest in order that the gravity field remains uniform. If the extent of the climb is too great the value of local gravitational attraction and acceleration would be reduced which would be represented by a flattening of the angle between the inclined plane and the horizontal, as shown below.

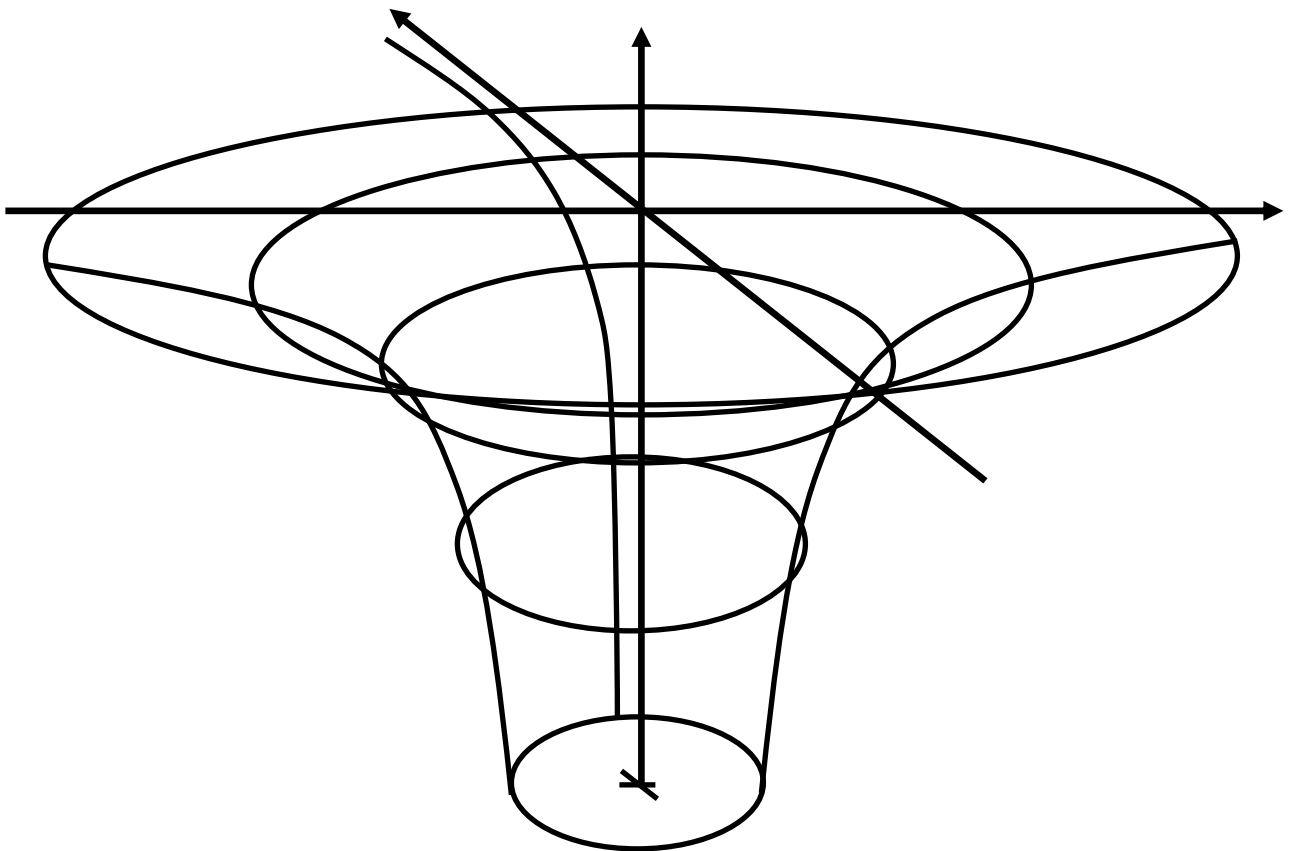

INTRODUCTION TO GRAVITY-WELL MODELS OF CELESTIAL OBJECTS

Galileo appreciated the intimate relationship between mathematics, and both hypothetical and experimental physics. He understood the parabola in terms of the conic section and also expressed as the ordinate (y for height) varying as the square of the value of the abscissa (x for the horizontal distance downrange relative to the launch point on a flat non-rotating Earth). Galileo further understood that the parabola was only the theoretical trajectory of a uniformly accelerated projectile moving under the influence of gravity and ignoring air resistance. He acknowledged that there are limits to the accuracy of his theory, noting that a real trajectory of very large size covering too great a range or climb distance could not possibly be a mathematically precise parabola, but he maintained that for distances up to the range of his contemporary artillery the deviation of a projectile's path from a parabola would be minor. He recognized that his experimental data would never agree exactly with any theoretical or mathematically derived data because of unavoidable measurement errors, friction, and other factors.

In more recent years, students of physics have used a small device called a Fletchers Trolley (which is very similar to Galileo's inclined track and rolling ball) to study uniformly accelerated motion, as well as basic photographic methods employing a strobe light similar to that illustrated below, to directly observe projectile motion in a uniform gravity field.

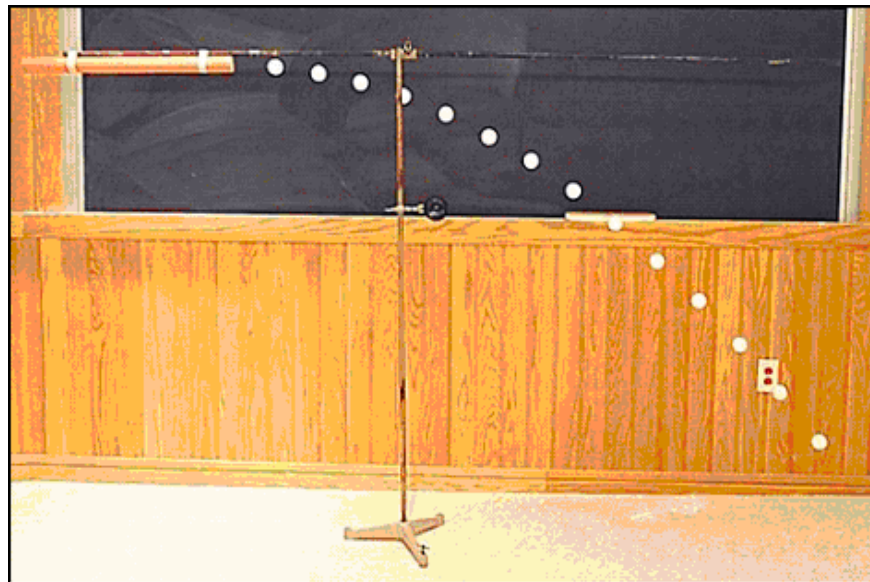

Figure-12 Laboratory Demonstration of Parabolic Projectile Motion in a Gravity Field

3.2 Kepler's Three Laws of Planetary Motion

Kepler's laws may be simply stated as follows:

1. The orbit of every planet is an ellipse with the Sun located at one focus.
2. The line joining a planet and the Sun sweeps out equal areas during equal times.
3. The square of the time a planet takes to orbit the Sun is directly proportional to the cube of the planets mean distance (called the semi-major axis) from the Sun.

INTRODUCTION TO GRAVITY-WELL MODELS OF CELESTIAL OBJECTS

To recap and emphasize, Kepler worked for over 20 years to arrive at his laws of planetary motion. Since these were formulated *without* the aid of physical theory, Kepler's approach was empirical and at times guided by his personal notions of beauty. It is therefore understandable that this task took him two decades to complete. **However, when Newton was later able to dispassionately derive Kepler's three laws by assuming an inverse square law for the gravitational attractive force, Newton's theory scored a resounding victory in science. Kepler's three laws are described and illustrated below, and further discussed in Appendix-A.**

1. K1 The orbit of every planet is an ellipse with the Sun located at one focus.

The geometry of the ellipse and the mathematical relationships between its geometric elements were well understood at the time of the discovery of Kepler's three laws. It followed that excellent predictions could be made which compared precisely with the observed motions of the planets.

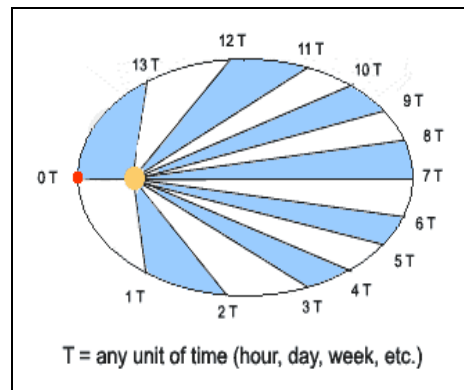

www.nasa.gov

2. K2 The line joining a planet and Sun sweeps out equal areas in equal times.

As illustrated above, when at a relatively small distance from the Sun the planet sweeps out a larger and more *obtuse angle in a given period of time*. Conversely, and when located at a larger distance from the Sun, the planet sweeps out a smaller and more *acute angle in that same time*. Therefore, a planet travels fastest nearest the Sun and slowest when most distant from the Sun, and the radius demonstrates what is termed constant "*areal velocity*". To clarify, the white and blue sectors above all have equal areas and represent the same time of travel over each one of the fourteen individual sectors, and one fourteenth of the total orbital period to complete an orbit.

3. K3 The square of the time a planet requires to orbit the Sun is directly proportional to the cube of the planets mean distance from the Sun.

This third rule became known as the harmonic law and predicts exactly how long a planet requires to orbit the Sun. Kepler's three laws can be used to make accurate predictions of planetary positions, velocities, and the transit times between these. The underlying physics behind these laws had not yet been developed. Although other great scientists of the time had some solid thoughts on gravity, it required the disciplined mind of Sir Isaac Newton to explain the physics of these laws.

INTRODUCTION TO GRAVITY-WELL MODELS OF CELESTIAL OBJECTS

Newton's inverse square law of universal gravitational attraction was needed. The well known astronomer Sir Edmond Halley offered to bear the considerable printing costs if Newton could develop and publish the physics behind Kepler's three laws. Newton was up to the task, and claimed to know the solution to the problem having worked with it before. He collected his thoughts, meticulously cleaned them up and ultimately published the formal Principia and described the so called "System of the World".

3.3 Newton's Three Laws, Universal Law of Gravitation, and Planetary Motion

"If I have done the public any service, it is due to my patient thought." - Newton

Newton's Three Laws of motion are the fundamental principles that form the basis of classical mechanics. They describe the relationship between the **forces** acting on a body and the resulting **motions** produced by those forces. They have been verbally expressed in numerous ways, and can be summarized as follows:

N1 First Law: *A body at rest tends to remain at rest. A body in motion tends to remain in motion and moves at constant speed along a straight line.* Every physical body remains in a state of rest or uniform motion unless acted upon by an external unbalanced force.

N2 Second Law: A body of mass ***m*** subjected to a net force ***F*** undergoes a resulting acceleration ***a***, that has the same direction as the net force and a magnitude that is directly proportional to the net force and inversely proportional to the mass of the body, i.e., **$F = ma$** . Alternatively, the total force applied to a body is equal to the time rate of change of *linear momentum* (i.e., $m \times v$) of the body.

N3 Third Law: The mutual forces of "action and reaction" between two bodies are equal, opposite and collinear. This means that whenever a first body exerts a force ***F*** on a second body, the second body exerts a corresponding force **$-F$** on the first body. ***F*** and **$-F$** are equal in magnitude and opposite in direction.

The three laws of motion were first stated by Sir Isaac Newton in his Philosophiæ Naturalis Principia Mathematica. His above three laws were used to explain and further investigate the motion of physical objects. Newton showed that the laws of motion, combined with his new ***universal law of gravitation*** below, fully explained Kepler's laws of planetary motion.

Newton ***never*** fully explained, however, the physical origin, mechanism, or underlying causes of gravity, and restricted his work to relating the magnitude of this "action at a distance force" to other observables (i.e., *M*, *m* and *R*) which worked very accurately. Newton assumed gravity to act instantaneously over any distance, implying that gravitation traveled at an infinite speed. It is reported that this disturbed Newton, and left him somewhat unsatisfied in this regard.

Newton's Universal Law of Gravitation

$$F = (G M \times m) / R^2$$

3.4 Einstein's Laws of Gravitation and Spacetime Curvature

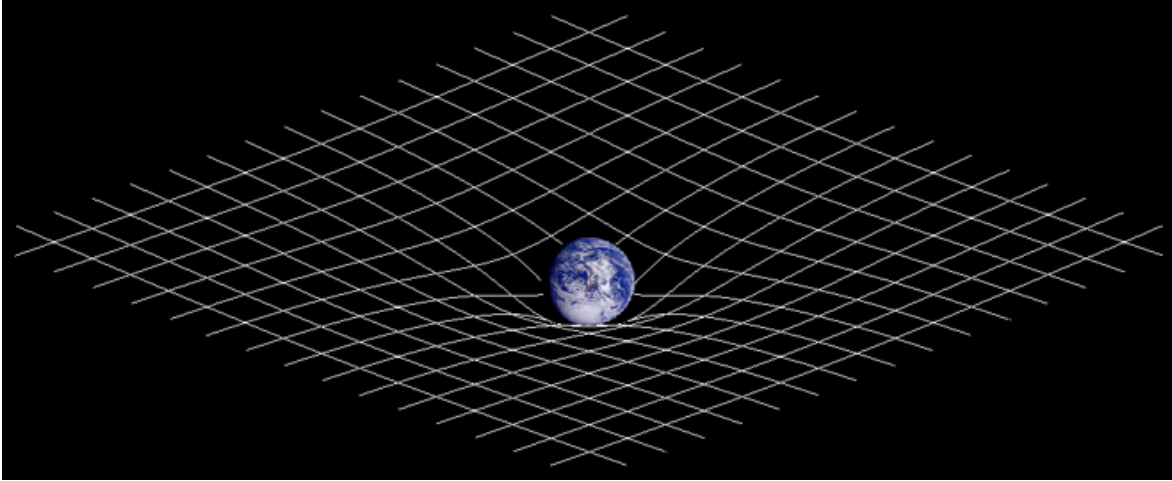

Figure-13 Graphical Interpretation of Einstein's "Fabric of Spacetime"– Johnstone @ www.wikipedia.org

Isaac Newton believed that space was effectively a three dimensional *stage* on which world events transpired with the natural passage of time. Newton's space was totally independent of time, and time of space. Einstein mathematically *weaved* the four dimensions of space and time (i.e., x, y, z, and t) into the fabric of a newly unified "spacetime continuum". We experience both space and time, but in a related and "relative" way. With his revolutionary changes to Newton's system of the world, Albert Einstein was able to reproduce the effects of gravitating matter with the curvature of this new continuum, which is nicely illustrated above and on the web by Johnstone. In Einstein's new world view, orbital motion was an exercise in higher order geometry. Planets moved in orbits along the straightest paths possible in this higher space, called "geodesics" around their Sun. As defined in mathematics, a **geodesic** is a generalization of the notion of a "straight line" for "curved spaces". *Unfortunately, book keeping these concepts in general relativity necessitated some relatively complex mathematics, which Einstein first needed to learn for himself. Reported to be a lover of simplicity and intuition, if he had a simpler mathematical alternative for his theory he would have quickly embraced it.*

In place of Newton's gravitational force, Einstein explained the effects of gravity as the warping or curving of the fabric of the spacetime continuum. It was not forces which were responsible for orbital motion, but **mass which told spacetime how to curve, and curved spacetime which told matter how to move**. The price many of us pay for this, is difficulty appreciating the non-intuitive idea of a four dimensional spacetime. Einstein's new continuum included the three spatial dimensions and the single temporal dimension of time. *This new continuum was sought and mathematically accepted by Einstein because it was then desperately needed to explain the constant speed of light, which was by all observations invariant under every tested condition. Up until these observations there was no need for spacetime, and Newton's simple space was sufficient for science.* Einstein's higher order geometry is real enough for *GPS satellites* to obey and depend on its rules of relative space and time for their proper operation, and every experiment performed to date shows that this model has all the properties required to qualify it as a valid world view (see Clifford Will's, **Was Einstein Right?**).

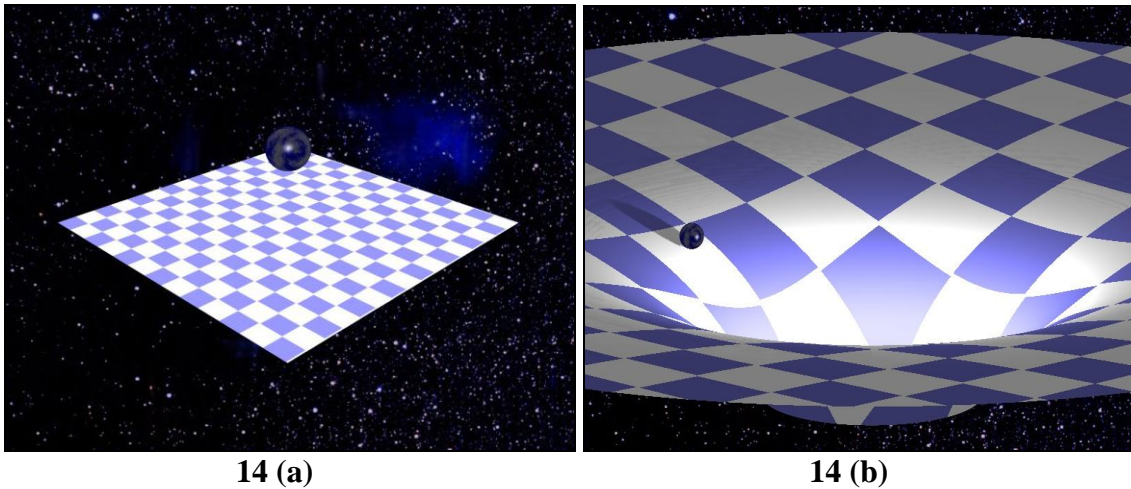

Figure-14 Mass Tells Spacetime How to Curve and Spacetime Tells Matter How to Move-
www.spaceanimations.org

3.4.1 Flexible Membrane Analogy for Spacetime and the Gravity-Well:

Another way of thinking about matter warping space is to first imagine a locally mass free flat space as you would be taught but flexible surface of a *trampoline*, illustrated in Figure-14(a). Mentally place a heavy bowling ball at the center of the initially flat trampoline. The bowling ball represents the mass of the star in the modeled solar system. Naturally, due to the weight of the bowling ball and the elasticity of the fabric, the bowling ball once placed on the membrane drops out of sight and into the initially flat surface, leaving in its wake the curved surface of the gravity-well, as illustrated in Figure-14(b).

I remember seeing this subject presented during a televised feature on Einstein's gravity in the late-60s. The enthusiastic scientist projected small ball bearings along the curved rubber membrane surface which orbited this flexible gravity well beautifully. *An added benefit of this modeling approach is that the trampoline surface assumes a slightly warped shape immediately beneath the rolling ball while in contact with the surface*, similar to what Einstein's spacetime experiences. With this model we have produced a mini and moving gravity-well beneath the advancing ball, which orbits the larger central well. Due to partially *irreversible friction losses* inherent in a flexible membrane, this would be a short lived advantage, since a *rigid surface model* coated with the low friction material permits the ball to orbit longer before succumbing to friction losses. Engineers would say that a *rigid well* has a lower *friction coefficient* because of a smaller "*friction circle*". However, the flexible membrane is conceptually a better analogy to Einstein's gravity since the *geometry of the membrane reacts to both the presence and quantity of "gravitating matter"*.

When a suitable mass per unit surface area is used for the fabric, the flexible membrane analogy can be extended to demonstrate the tremendous, but finite speed of gravity. The propagation speed of gravity was assumed by Newton to be infinite, who was disturbed by this "instantaneous action at a distance" form of gravity. Although never directly demonstrated, Einstein concluded that gravity travels at the same speed as does light (c). Einstein had already established that the speed of light is the highest possible speed for any signal. Note that if the seated bowling ball is disturbed (i.e., tapped or suddenly moved) on a membrane having the correct mass-elastic properties) one can demonstrate, at least in principle, the concept of gravity waves and their finite but tremendous speed to scale on a flexible membrane gravity-well. The reader is invited to see "Gravity-Well Models of Celestial Objects" for additional details and mathematics.

INTRODUCTION TO GRAVITY-WELL MODELS OF CELESTIAL OBJECTS

4.0 BASIC ORBITAL MOTION AND THE GRAVITY-WELL

The wonder of natural orbits is that they may be described using simple **conic sections**. A conic section is formed by the intersection of a cutting plane and right circular cone, thereby producing a **circle, ellipse, parabola or hyperbola**. As illustrated below and on the next page, any natural Keplerian orbit may have an eccentricity which is exactly equal to zero for a circle ($e_c=0.0$), between zero and one for an ellipse ($0 < e_e < 1$), exactly equal to one for a parabola ($e_p=1.0$), or greater than one for a hyperbola ($e_h > 1.0$). Eccentricity is a measure of the shape of the conic and generally the larger the value of “e”, the flatter the orbit. A conic section is defined as the locus of points in space whose ratio of distances from a fixed point and line is constant, called the eccentricity.

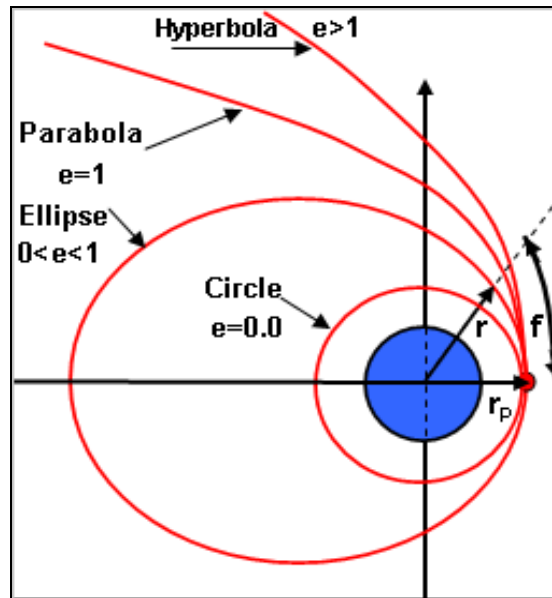

Orbits are Conic Sections

*Just why** the geometry of a conic section faithfully represents an orbit around a single gravitating body can not really be answered. In this instance we should think of the conic section as just another result of Newton’s physics and a consequence of our beautiful mathematics. Any further thoughts we might have on the matter probably says more about us than any orbit.

Among a handful of characterizing constants we will introduce to describe Keplerian orbits, there also exists the **true anomaly angle “f”** shown above, measured within the orbital plane between the lowest or minimum radius in orbit, called the “pericenter” (or r_p), and our current location in orbit. The true anomaly angle “f” locates our instantaneous position in orbit at any time t past pericenter.

* This is only a single example of this type of occurrence in physics. Other examples include: baseballs projected in constant gravity fields and *electrons in uniform electric fields* which travel along parabolas, structural cables having *self weight* hang in the shape of a perfect centenary, suspension bridge cables *supporting a massive but uniform roadbed* hang in parabolas, a single drop of water initially released from a dropper forms a sphere from its surface tension, and then becomes a tear shaped object as it falls and accumulates speed and streamlining air drag, etc.).

INTRODUCTION TO GRAVITY-WELL MODELS OF CELESTIAL OBJECTS

A conic section is formed by the four types of intersection produced by a *cutting plane* and a *right circular cone*, illustrated below. As noted previously, this intersection results in a *circle*, *ellipse*, *parabola* or *hyperbola*. The type of conic and shape of the orbit depend on the orientation of the cutting plane α , and the relative size of the semi-cone angle β .

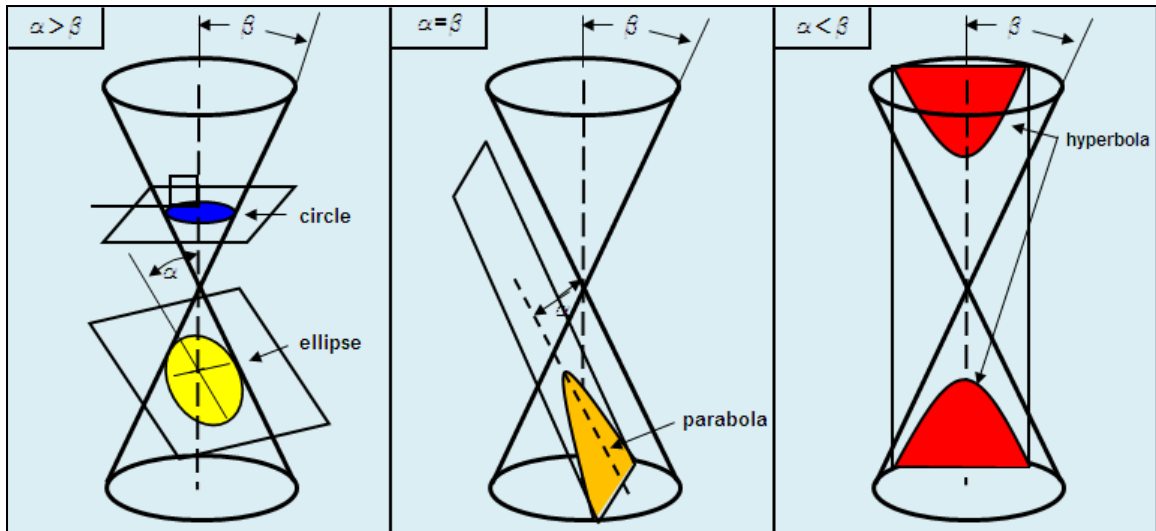

Orbits are Conic Sections

Note that the conic section and resulting shape of the orbit **reside in the common plane of intersection**. The relative values of the *semi-cone angle* β and the *cutting plane angle* α , are also important (**i.e., if $\alpha > \beta$, $\alpha = \beta$, & $\alpha < \beta$**).

- 1) As shown in the *left* panel for $\alpha > \beta$, the required angle α , between the cutting plane and the centerline of the cone must be precisely 90 degrees to generate the **circle (shown in blue)**.
- 2) As also shown in the *left* panel for $\alpha > \beta$, the magnitude of the angle α , must be greater than the semi-cone angle β and less than 90 degrees to produce the **ellipse (shown in yellow)**.
- 3) As shown in the *middle* panel for $\alpha = \beta$, the plane angle α required to produce the **parabola (in orange)** must be precisely equal to the semi-cone angle (β).
- 4) As shown in the *right* panel for $\alpha < \beta$, in order to generate the (two legged) **hyperbola (shown in red)**, α , the cutting plane angle measured to the cone centerline, must be **equal to, or greater than 0.0 and less than the semi-cone angle (β)**.

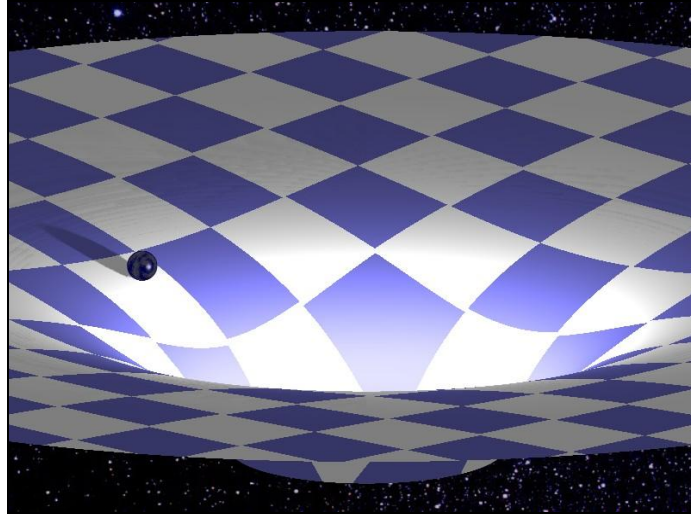

A Body orbiting within a Gravity-Well - www.spaceanimations.org

Note: Appendix-B contains computer generated illustrations of circular and elliptical orbits of the Earth – www.spaceanimations.org.

4.1 Circular Orbits (eccentricity $e=0$, a special case of ellipse)

We see illustrated in the above figure a ball rolling in a circular orbit around the gravity-well. The circular orbit is illuminated and rendered using a point light source in the geometry model. When the ball is projected into a horizontal plane along the surface of the well with its initial velocity *perpendicular* to its instantaneous radius to the well center and with *precisely the correct value of speed*, it is in a circular orbit. Any faster than this circular speed and the ball rises, any slower and it descends. A circular orbit on the well will maintain a constant speed and distance from the well center and a fixed elevation (ignoring friction and windage) on the gravity-well. **The reader is invited to see “Gravity-Well Models of Celestial Objects” for additional details, and the governing equations.**

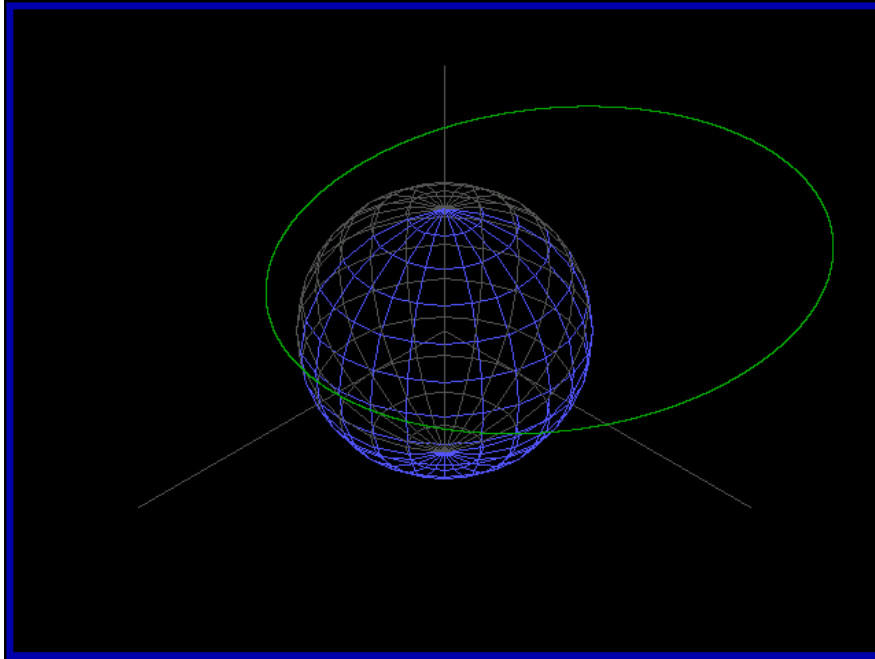

An elliptical orbit-www.spaceanimations.org

4.2 Elliptical Orbits (eccentricity $0 < e < 1$) within their orbital plane

Ellipses are a more general case of orbit in which the *velocity of the orbiting body varies* from a *maximum speed* at the point of closest approach to the Earth, called the perigee, to a *minimum speed* when most distant, called the apogee. ***When speaking in the context of a ball rolling on the gravity-well, it is suggested that the more general terms “pericenter” and “apocenter” be used, as these terms apply to all circumstances.***

An ellipse type of shape is produced by a satellite in space (or a ball on the gravity-well) when it is projected at insert with a **greater** velocity than what is required for maintaining a purely circular orbit. The ball therefore rises above this point, and in gaining height and radius the ball gains potential energy at the expense of kinetic energy (and speed) until its subsequent velocity is insufficient to orbit in a pure circle. It therefore descends downward, only to oscillate up and down forming an ellipse like trajectory. **The reader is invited to see “Gravity-Well Models of Celestial Objects” for additional details and working equations for elliptical orbits.**

4.3 Parabolic Orbits ($e=1$)

The minimum energy escape trajectory from the Earth or any celestial body is parabolic in shape and has a numerical value of eccentricity exactly equal to one ($e=1.0$). As such, it is a special case of a just super elliptical orbit for which *escape velocity* is a **minimum**. Of course, *the shapes of all escape trajectories are open as they do not close on themselves*. The equation for the parabola is similar in form to that of an ellipse in which the eccentricity is assigned a value of exactly 1.0. Willy Ley, one of the original founding members of the German Rocket Society, has written that in his opinion, there are no precisely parabolic (or for that matter pure circular) trajectories since every orbital eccentricity when written out to a sufficient number of decimal places, will deviate, however slightly from exactly 1.0 (or 0.0 for the circular case).

INTRODUCTION TO GRAVITY-WELL MODELS OF CELESTIAL OBJECTS

This is actually true, although when a circular orbit deviates slightly from a true circle, it *is still in an approximately circular* orbit, and can be more simply book kept as one. The same is true for an escape orbit which is only slightly super-parabolic, known as a hyperbolic escape trajectory. As such, a slightly hyperbolic trajectory may have an orbital eccentricity of just over **1.0** (e.g., 1.00000001), but be adequately represented by a parabola having an eccentricity of **1.0**. It is a matter of application and convenience.

In the context of the gravity-well, an *escape parabola* would permit a rolling ball so projected to be capable of ascending to the most distant and furthest modeled position along the gravity-well wall. If the gravity-well could actually be modeled out to an *infinite radius*, that most distant and theoretical point along the well would have a zero slope and *be quite flat*. All of the initial kinetic energy of motion of the ball near pericenter would be *replaced by only potential energy of height* at the distant apocenter. It is at this distant and theoretical flat point along the parabolic trajectory that the ball would very slowly come to rest. We say, therefore, that the ball has *escaped from the well center*, and for this reason the parabolic trajectory is said to be an “escape trajectory”. **The reader is invited to see “Gravity-Well Models of Celestial Objects” for additional details and working equations describing parabolic trajectories.**

4.4 Hyperbolic Orbits ($e > 1$)

In the context of the gravity-well, an *escape hyperbola* would permit a rolling ball projected with *greater than parabolic velocity* to climb not just to, but infinitely *beyond* the most distant and furthest position along the well wall. At this great distance the slope of the well flattens out and remains level beyond. Instead of the ball slowly coming to rest, it would *travel with some remaining linear velocity*, called “*residual velocity*”. Here the well surface becomes an extended flat annulus shaped area, where the ball would continue infinitely on out maintaining its residual speed.

All of the initial potential energy and kinetic energy of motion near pericenter would be replaced by both potential energy of height, *and* some remaining residual kinetic energy and its associated speed in deepest space. The *hyperbolic trajectory* can pass *beyond* that hypothetical point where a body with parabolic velocity would very slowly come to rest, and forever travel beyond that distant point maintaining constant residual velocity along this extended theoretical flat surface into deepest space.

We therefore also say that the ball has *escaped from the well*, and for this reason the *hyperbolic path* is said to be another form of *escape trajectory*, which can carry us out to gravity-field free space, or until we might cross the threshold of the gravitational *sphere of influence*, and the gravity-well of a different celestial body. Note that corrections must be made for the relative velocities of these moving gravity wells. **The reader is invited to see “Gravity-Well Models of Celestial Objects” for additional details and working equations for hyperbolic trajectories.**

INTRODUCTION TO GRAVITY-WELL MODELS OF CELESTIAL OBJECTS

4.5 Comments on Motions Observed on Gravity-Well Models

I can't recall how many times I have watched the gravity-well operate at the Hayden. At first, just to enjoy the show, and then more soberly while trying to make sense of its busy and continuous operation. The Hayden's *program* for dispensing balls was an important part of their overall demonstration. This included the *type of orbit*, the *number of balls*, as well as the *time of release* of each ball. Close timing was needed for an entertaining and informative show.

Planets: Each new planetary ball was introduced to the gravity-well by slowly gathering speed by *rolling down a calibrated and elevated acceleration ramp along the top left edge of the well shown below*. This *steel ramp* had the required *height* to project the ball at the desired velocity along the well. In this fashion every planetary ball began its orbital life as a model planet, and as a member of a tiny solar system.

The Hayden projected four such balls serially, spaced in time so that the *earlier* ball's orbit had decayed a bit, and had a slightly smaller orbit. Viewers were treated to watching these *planetary balls* simultaneously as they **orbited the well in near circular ellipses**. *The four balls could be thought to represent our first four inner planets, Mercury, Venus, Earth and Mars circling the model Sun at the well center*. Naturally, while circling the well these orbits gradually decayed, and slowly spiraled inward and downward due to the influence of friction on the rolling balls.

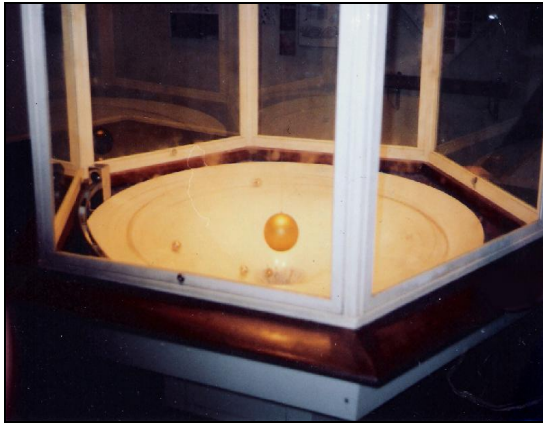

New York's Hayden Planetarium-1967



Boston Museum of Science-1980

Each ball steadily **increased in speed** due to **reduced orbital radius**, until the leading ball approached the central hole with *amazing speed and noise*. *After the ball had spiraled in and descended from the top to the bottom of the well, it rapidly circled round the bottom central hole, orbiting madly like a crazed daredevil*. Just when you thought the ball might continue indefinitely, it suddenly disappeared from sight and down the central hole with a muted but definite **thump**. Immediately on the heels of the first ball's departure down the hole, a new planetary ball was automatically dispensed at the top of the well to repeat the entire process.

INTRODUCTION TO GRAVITY-WELL MODELS OF CELESTIAL OBJECTS

Precession: *One comment regarding the motions of planetary balls is that their near circular and slightly elliptical motions were observed to **precess**.* In the context of gravity-wells, *precession* produces a steady rotation of the ellipse and its axis of symmetry in the direction of rotation during each orbit. The axis of symmetry runs between the apocenter and pericenter of the rotating ellipse, and results in the *angular advance of pericenter* in orbit by a few degrees every well orbit.

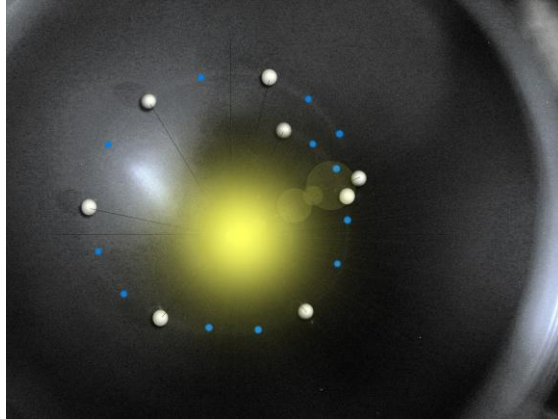

Touched up time exposure taken by the author of the spiraling and precessing motions of a ball traveling in a roughly circular ellipse on a model gravity-well

This motion was only slightly like that of the actual planet Mercury. I say slightly, since Mercury experiences a very slight advance of pericenter by *precession*, and for different, but related reasons. Most of the small *precession angle* of the actual planet Mercury can be explained by Newton's laws as due to small disturbances or *perturbations*, produced by the other planets. Only, a very minute fraction of the total *precession angle* of Mercury was explained by Einstein as produced by the *greater curvature of spacetime close to the more gravity warped space surrounding our Sun; the larger remainder being due to the planets*. Since Mercury is the first and closest of all the planets to the Sun, it has demonstrated this slight orbital **precession** attributable to the relativistic effects of **curved spacetime**.

Comets: Next, without warning, the routine order of the above planetary series of balls would be broken by the loud *crack* of a single high speed projectile representing a solitary *comet* rapidly invading our solar system. Some comets are often near parabolic with eccentricities close to 1.0. However, others are elliptical as is Halley's Comet, which travels along an elongated ellipse with an eccentricity of about 0.97, and repeats its orbit about every 76 years. This *fast comet like ball* had a significantly greater *inward motion* than the previous near circular planetary balls. The simulated well comet would quickly travel somewhat radially and more directly towards the central *Sun, in its near parabolic orbit*, then travel very rapidly round the Sun at perihelion. Last, almost as quickly as it appeared, return to deep space and roll off the top outer edge of the model, somewhere along the perimeter of the well. This speedy comet like motion was almost over before it began, and required one to keep a sharp watch to see it.

INTRODUCTION TO GRAVITY-WELL MODELS OF CELESTIAL OBJECTS

5.0 CONCLUDING REMARKS

What is the ultimate fate of the gravity-well? Over the years, the gravity-well become an object of *commerce*. Gravity-well exhibits can now be purchased for between \$1,000 and \$10,000 dollars for sale on the web. The first commercial well was made and patented in 1985 by Mr. Steve Divnick, the inventor of the coin well who now operates www.spiralwishingwells.com. Improved commercial models, additional patents, sizes and colors have been added over the years.

5.1 The Commerce of Gravity-wells

The commercial appearance of the gravity-well has become more commonplace with the passage of time. Many of these wells are designed to permit the use of coins in place of ball bearings to represent orbiting bodies. It has lost a little of its “scientific” luster for many but the gravity-well obsessed author, and children (including my grandson) who just love to watch it operate. This makes the current vintage of gravity-well a very sensible item to exhibit at any public gathering, which pays for itself in a short time by gathering the coins of the curious and raising funds for charity including the continued operation of small museums, educational institutions and other good causes. Noteworthy among these is www.spiralwishingwells.com whose fine wells have earned over \$200 million dollars for many charitable causes. Spiral Wishing Wells also supports teachers, education and research efforts with non-profit grants.



**Mini-Gravity-well model in my Home Office
Coin Vortex by www.spiralwishingwells.com**



Larger Gravity-wells on Public Exhibition used for Fund Raising

Reproduced with Permission of www.spiralwishingwells.com who have raised over \$200 million for charities, organizations, and museums with this device

INTRODUCTION TO GRAVITY-WELL MODELS OF CELESTIAL OBJECTS



Commercially Available Coin or Ball Bearing Type Gravity-Wells
Graphic Reproduced with the Permission of www.spiralwishingwells.com



Commercially Available Coin or Ball Bearing Type Gravity-Wells
Graphic Reproduced with the Permission of www.spiralwishingwells.com

INTRODUCTION TO GRAVITY-WELL MODELS OF CELESTIAL OBJECTS



**Commercially Available Coin or Ball Bearing Type Gravity-Wells
Graphic Reproduced with the Permission of www.spiralwishingwells.com**

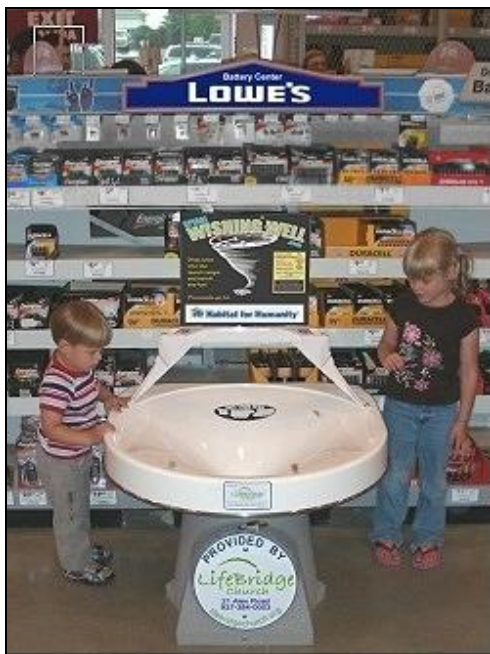

**Commercially Available Coin or Ball Bearing Type Gravity-Wells
Appeals to Children of All Ages
Graphic Reproduced with the Permission of www.spiralwishingwells.com**

INTRODUCTION TO GRAVITY-WELL MODELS OF CELESTIAL OBJECTS

5.2 My final thoughts on the subject of gravity-wells is that in the right environment, under correct conditions of lighting and ambient noise, gravity-well exhibits can still be used to instill interest, and scientific curiosity in both children and adults.

This has been accomplished by the Carter Observatory exhibit on a very reasonable scale and is shown below in the photograph they provided showing two small children with their interest fully engaged. Who can say where this first attention will take them? Such exhibits providing a setting suitable for learning and appreciating the laws of science and perhaps awe for our often beautiful universe are still needed.

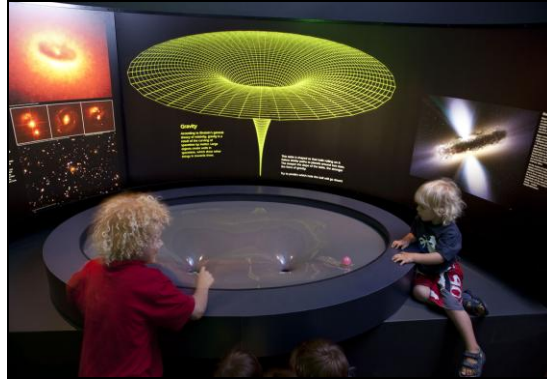

**Children Enjoying Model of the Gravity Field of a Binary Star System
With Permission and Courtesy of Carter Observatory in New Zealand**

I had visited the old Hayden Planetarium for many years as a child and into my adulthood. Always most impressed by the model solar system exhibit which was located in a dedicated and darkened room located on the first floor beneath the great star dome. My next favorite was the star show projected above. In the Solar System Room the revered human speaker, rather than a recording, would stand off to the side and below the planets and comment on our solar system. These models were outfitted with their model moons and rings which slowly moved in their coordinated orbits, suspended to the overhead with barely visible tracks.

As a New Yorker, I spent a large portion of my formative years viewing the magnificent exhibits of the American Museum of Natural History and Hayden planetarium. These included their large meteorite collection, many beautiful celestial murals, the historic Martin Viking Sounding Rocket, telescopes, ancient timepieces and optical devices, and many other wonderful items too numerous to mention.

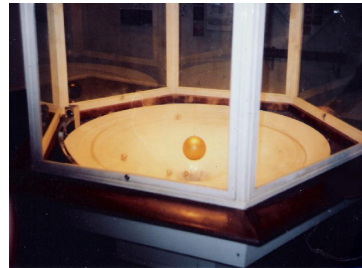

There were many distracting exhibits at the Hayden, but when the modest and expertly crafted gravity-well model first appeared, it grabbed my imagination like no other, resulting in much self study and this book. Who can say where any first attention will take us?

INTRODUCTION TO GRAVITY-WELL MODELS OF CELESTIAL OBJECTS

6.0 REFERENCES, BOOKS, & SUGGESTED READING MATERIALS

Please note that the following reading materials are listed in order of their publication dates:

- 1) Vladimir Fock, *The Theory of Space, Time, and Gravitation*, Translated from the Russian by N. Kemmer, Pergamon, New York, 1959. **An advanced level mathematical discussion of the subject of gravity.**
- 2) Reginald J. Stephenson, *Mechanics and Properties of Matter*, John Wiley & Sons, Inc., 1960, **Intermediate level mathematical introduction to Kepler's laws of celestial motions.**
- 3) Irving H. Shames, *Engineering Mechanics*, Prentice-Hall, Inc., Englewood Cliffs New Jersey, 1960, **Intermediate engineering and college level mathematical introduction to motions in a Central Force Field.**
- 4) Arthur C. Clarke, *The Exploration of Space*, Printed by Kingsport Press, 1961. **A simple descriptive introduction to the gravity-well concept.**
- 5) Willey Ley, *Satellites, Rockets and Outer Space*, Signet Science Library, 1961. **Another simple and basic introduction to the gravity-well concept, and the vortex or solar whirlpool analogy by Willey Ley.**
- 6) Nelson and Loft, *Space Mechanics, Statics and Dynamics*, Prentice Hall International Series and Space Technology, Prentice Hall Englewood Cliffs, NJ. 1962, **Engineering level discussion of the Role of the Moon in the Production of Tides and Tidal Friction.**
- 7) Battin, *Astronautical Guidance*, McGraw-Hill Electronic Science Series, 1964, **A graduate engineering text book from MIT on Astronautical guidance in orbit.**
- 8) Peter van de Kamp, *Elements of Astromechanics*, W.H. Freeman and Company, 1964, **An excellent and simple to follow mathematical introduction by a world class astronomer to celestial mechanics, the rotating binary and the LaGrange Restricted Three Body Problem.**
- 10) Archie E. Roy, *The Foundations of Astrodynamics*, The Macmillan Company, 1967, **Graduate engineering details on the Rotating Binary and the LaGrange Restricted Three Body Problem.**
- 11) Albert Shadowitz, Department of Physics Fairleigh Dickinson University, *Special Relativity*, W. B. Saunders Company, 1968. **Intermediate to graduate level physics introduction and a mathematical (and graphic) definition of the "Interval" in spacetime, world lines, length, mass, time, charge, momentum, etc.**
- 12) Dr. Wallace Arthur and Dr. Saul K. Fenster of Fairleigh Dickinson University, *Mechanics*, Holt, Rinehart, and Winston, Inc. 1969. **Details on Motions in a Central Force Field (both gravitating and of charged particle)**
- 13) P. A. M. Dirac, *General Theory of Relativity*, John Wiley and Sons, 1975. **Advanced level mathematical discussion of the subject.**
- 14) H. L. Shipman, *Black Holes, Quasars, & the Universe*, Houghton Mifflin Company, Boston, 1976, **A popular discussion of black hole theory**
- 15) Nigel Calder, *Einstein's Universe*, Viking Press, NY, 1979, **A wonderful and easy to understand book on relativity that reads like poetry.**
- 16) Clifford Will, *Was Einstein Right?: Putting General Relativity to the Test*, New York: Basic Books, 1986, **Discusses the many successful past tests as well as more current and further recent experiments performed to validate Einstein's theory made possible by advances in technology.**
- 17) Dr. A. Zee, *Einstein's Universe Gravity at Work and Play*, Oxford University Press, 1989, **A fascinating and authoritative main stream popular book including very informed speculations on gravity**
- 18) Alyn & Allison Duxbury, *Introduction to the World's Oceans*, 1989. **Very detailed Information on the formation of the tides**
- 19) John Gribbin, *Unveiling the Edge of Time (Black Holes, White Holes, Wormholes)*, Three Rivers Press, NY, 1992, **Wonderful popular book on Black Hole Theory and the strange structures of general relativity.**
- 20) J-P Luminet, *Black Holes*, Cambridge University Press, 1992, **Also, one of the most authoritative popular books on the Black Hole by a French specialist and astronomer working with the Meudon Observatory**

INTRODUCTION TO GRAVITY-WELL MODELS OF CELESTIAL OBJECTS

- 21) Tom Van Flandern, *Dark Matter Missing Planets & New Comets, Paradoxes Resolved Origins Illuminated*, North American Books, 1993, A non-mainstream book which should be read by every defender of the confidence we have in science and the value of scientific consensus.
- 22) Kip S. Thorne, *Black Holes & Time Warps, Einstein's Outrageous Legacy*, W. W Norton & Company, New York, NY, 1994, One of the most definitive popular books on the history and cosmology of black holes.
- 23) Ignazio Ciufolini and John Archibald *Wheeler, Gravitation and Inertia*, Princeton Series in Physics, Published by Princeton University Press, Princeton, New Jersey, 1995, This text book reads very easily, but has much mathematics. However, the narratives are filled with metaphor and physical meaning. These gentlemen write with all the authority of their accomplishments (Note that John A . Wheeler coined the term black hole).

7.0 Popular Articles, Technical Papers, and Web Papers

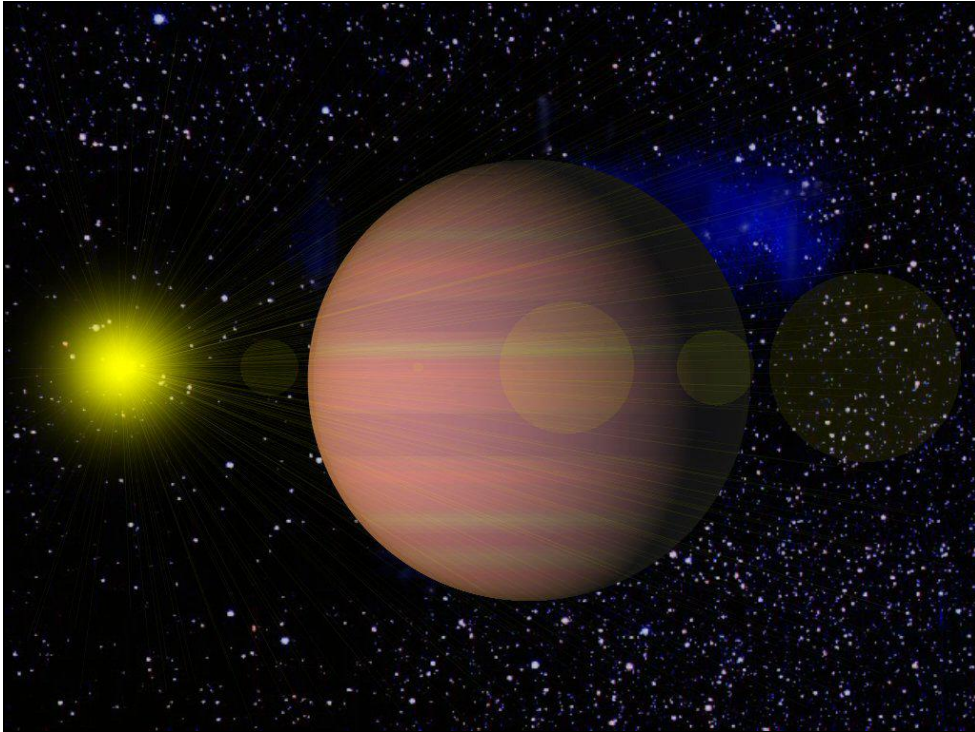

www.spaceanimations.org

Please note that the following papers, articles and web literature are listed from the most *current* to the *oldest* date, in reverse order of their publication dates:

- 1) The Study of the Anomalous Acceleration of the Pioneer 10 and 11, S. G. Turyshev, J. D. Anderson (*Jet Propulsion Laboratory, Caltech*), M. M. Nieto (*Los Alamos National Laboratory, U of California*), *The XXII Texas Symposium, December 13-17, 2004, The Anomalous Orbital Motions of the Deep Space Probes Pioneer 10 and 11.* -<http://science.jpl.nasa.gov/people/Turyshev/>
- 2) The Pioneer 10 and 11 anomalous acceleration and Oort cloud comets, Daniel P. Whitmire and John J. Matese, Department of Physics, University of Louisiana at Lafayette, January – April 2003 *The Anomalous Orbital Motions of the Deep Space Probes Pioneer 10 and 11 past the planet Jupiter*-<http://www.ucla.edu/~dpw9254/108536.pdf>
- 3) *Regular Keplerian Motions in Classical Many-Body Systems*, Eugene I. Butikov, St Petersburg State University, St Petersburg Russia, *European Journal of Physics*, 21 (2000) 1-18.
- 4) *Winners of the CISE Software Competition (for Educational Software)*, Denis Donnelly, Donnelly@siena.edu, Nov / Dec 1999.

APPENDIX A Page A-1

This article was originally published in SPECTRA, the student publication of the Fairleigh Dickinson University College of Science and Engineering, April 1968.



STUDENT PUBLICATION OF THE **COLLEGE OF SCIENCE AND ENGINEERING**

ELLIOTT BRILLIANT
Editor-in-Chief

NORMAN LANES
Managing Editor

JEFFREY LOZMAN
Advisory Editor

MARTIN WISHNOW
Business Manager

Editorial Staff

JOHN CUADRADO
JOHN DUFFY
MELVIN GRABEN
WAN-YOK HIOE
PAUL JANKOWSKI
MARJA JONGEDYK
JAMES R. STINE

Staff

RUTH CLUGGISH
JANET ZEIDLER
DONNA TRETIAK

Advertising Manager

LAWRENCE KLEIN

Photographic Director

ALEX CZETO

Faculty Advisor

DR. SALVATORE GIMELLI

VOL. 4, NO. 2 APRIL, 1968

Contents

ARTICLES

Limb Morphogenesis in the Chicken 9
Jeffrey Lozman

An Introduction To Thermonuclear Control 16
Marja C. M. Jongedyk and
Richard L. Schlosser

An Introduction To Digital Computers 23
Brian G. Boden

Gravity Analogue 29
Keith Mirenberg

FEATURES

Author's Page 4

Dean's Page 7

About the Cover: Capacitive and Inductive Grids in the Far Infrared 21
Charles Kramer

Bio-Medical Telemetry 34

spectra is published biannually by the students of the College of Science and Engineering of Fairleigh Dickinson University, Teaneck, New Jersey. About the Cover: See page 21.

APPENDIX A Page A-2

GRAVITY ANALOGUE

KEITH MIRENBERG

It can be said that the development of the accepted laws of orbital mechanics began with the work of Johannes Kepler. At this time the Copernican Hypothesis of a central sun with orbiting planets had already been formulated. However, this hypothesis needed further clarification. Kepler, who was a student of the astronomer Tycho Brahe, took upon himself the problem of explaining the motions of the planet Mars, as recorded by his teacher. After twenty years of work, he came to the conclusion that there were three basic laws which could rationalize the observed motions of the planets. These laws were formulated without the aid of any physical theory. When Newton was able to derive Kepler's laws by assuming an inverse square law of planetary attractive force, a major victory was scored for the Newtonian Theory.

Kepler's laws may be stated as follows:

- (1) A planet moves in an ellipse about its sun, which is located at one of the foci of the ellipse.
- (2) The area per unit time swept out by the line joining a planet and its sun is constant as the planet moves about the sun.
- (3) The square of the time it takes a planet to orbit its sun is proportional to the cube of its mean distance from the sun.

It is the aim of this article to provide an intuitive understanding of the basic laws of orbital mechanics.

To facilitate this, a concept will be introduced which can best be described as an orbital analogue.

Many of the phenomena observed in planetary motion may be represented by employing a surface of revolution and a ball. The ball plays the role of the satellite, and the surface simulates the gravitational field. If the surface is properly contoured, the ensuing motion of the ball along it will in many ways be analogous to orbital phenomena. Before the exact shape of this surface can be determined, we must mathematically describe the motions we seek to analogue.

The Central Force Field

Our survey of Kepler's laws begins with Newton's second law and the inverse square law of attraction as it applies to a sun and its planet, or

to a planet and its satellite,

$$\mathbf{F} = -\frac{GMm}{r^2} \hat{\mathbf{r}} \quad \text{Eq. A}$$

Where G is the Universal Gravitational Constant, M is the mass of the orbited planet, and m is the mass of the satellite. We shall assume in our derivation that the planet's center of mass may be considered the origin of an inertial frame of reference. Applying Newton's second law,

$$F \hat{\mathbf{r}} = m \frac{d\mathbf{V}}{dt} \quad \text{Eq. B}$$

$$F \frac{\mathbf{r}}{|\mathbf{r}|} = m \frac{d\mathbf{V}}{dt}$$

taking the cross product

$$\mathbf{r} \times F \frac{\mathbf{r}}{|\mathbf{r}|} = \mathbf{r} \times m \frac{d\mathbf{V}}{dt}$$

since $\mathbf{r} \times \mathbf{r} = 0$

then $\mathbf{r} \times m \frac{d\mathbf{V}}{dt} = 0$

As a result of the above,

$$\frac{d}{dt}(\mathbf{r} \times m\mathbf{V}) = 0$$

and $\mathbf{r} \times m\mathbf{V} = \mathbf{L}$

In which L is a vector of constant value. L is called the moment of momentum or angular momentum. We can see from the above derivation that this vector is constant in magnitude and has a constant orientation in a direction normal to the plane of the orbit.

The expression for angular momentum is:

$$\mathbf{L} = I\omega \quad \text{Eq. 1}$$

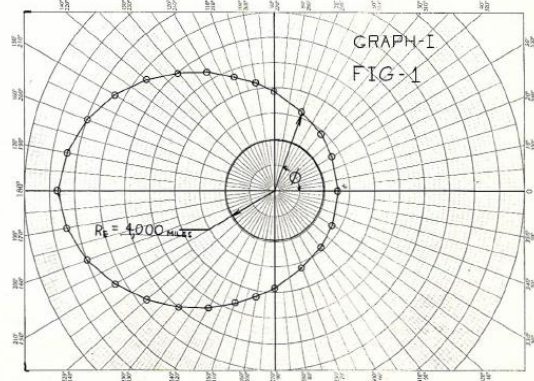

APPENDIX A Page A-3

In which $\omega = \frac{d\phi}{dt}$ and for a point mass, the moment of inertia about 0 is, $I = mr^2$.

Dividing both sides by m and defining $\frac{L}{m}$ as C we obtain:

$$C = r^2 \frac{d\phi}{dt} = \frac{L}{m}$$

The constant C is the angular momentum per unit mass. Substituting $\frac{d\phi}{dt} = \omega = \frac{V_\phi}{r}$ into Eq. 1,

$$C = r^2 \frac{V_\phi}{r} = rV_\phi \quad \text{Eq. 2}$$

Thus at any point in the orbit the satellite's tangential velocity is readily determined. The dimensions of C are those of length squared divided by time or area per unit time. We have thus derived Kepler's law of constant areal velocity.

From Figure 2, it is clear that

$$dA = \frac{r^2}{2} d\phi$$

Where dA is the differential area swept out by radius r during angular displacement $d\phi$.

$$\frac{dA}{dt} = \frac{r^2}{2} \frac{d\phi}{dt} = \frac{C}{2}$$

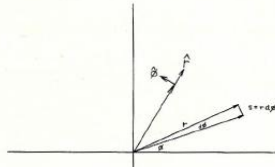

FIG-11

The areal velocity is thus found to equal one half the angular momentum per unit mass of the satellite.

In order to determine the general trajectory of the satellite we combine Eq. A and B, expressing the acceleration in polar coordinates:

$$m[(\ddot{r} - r\dot{\phi}^2)\hat{r} + (r\ddot{\phi} + 2\dot{r}\dot{\phi})\hat{\phi}] = -\frac{GMm}{r^2}\hat{r}$$

From which

$$\ddot{r} - r\dot{\phi}^2 = -\frac{GM}{r^2} \quad \text{Eq. 3}$$

$$r\ddot{\phi} + 2\dot{r}\dot{\phi} = 0 \quad \text{Eq. 4}$$

Consider the derivatives of r :

$$\dot{r} = \frac{dr}{dt} = \frac{dr}{d\phi} \left(\frac{d\phi}{dt} \right) = \frac{dr}{d\phi} \left(\frac{C}{r^2} \right)$$

Next the second derivative of r may be expressed,

$$\ddot{r} = \frac{d\dot{r}}{dt} = \frac{d}{dt} \left(\frac{C}{r^2} \frac{dr}{d\phi} \right) = \left[\frac{d}{d\phi} \left(\frac{C}{r^2} \frac{dr}{d\phi} \right) \right] \frac{C}{r^2}$$

The substitution $u = \frac{1}{r}$ simplifies solution of the differential equations leading to

$$\ddot{r} = \left[\frac{d}{d\phi} \left(Cu^2 \frac{d(u^{-1})}{d\phi} \right) \right] Cu^2$$

and

$$\ddot{r} - r\dot{\phi}^2 = -\frac{GM}{r^2}$$

Substituting this into Eq. 3,

$$\ddot{r} - r\dot{\phi}^2 = -\frac{GM}{r^2}$$

which results in the simple differential equation,

$$\frac{d^2u}{d\phi^2} + u = \frac{GM}{C^2}$$

the solution of which is:

$$u = \frac{1}{r} = \frac{GM}{C^2} + D \cos \phi$$

We recognize this function as the equation of the conic section in polar coordinates. The constant C has already been defined, the constant D may be found from initial conditions. The angle ϕ is the reference angle the radius r makes with the axis of symmetry of the conic. It can be shown that the eccentricity of the conic is given by:

$$\epsilon = \frac{DC^2}{GM}$$

Depending upon the value of the eccentricity, the orbit can be a circle ($\epsilon = 0$), ellipse ($0 < \epsilon < 1$), parabola ($\epsilon = 1$) or hyperbola ($\epsilon > 1$).

It should be pointed out that the equation containing tangential and Coriolis acceleration terms can be manipulated to produce the equation of constant areal velocity.

A simple example will show how to use the resulting functions. Given: A rocket vehicle has its engines shut down while it is at an altitude of 1000 miles. Its insertion speed with respect to the center of the Earth (an "inertial reference") is 19,750 MPH or about 29,000 FPS. Calculate C by means of Eq. 2.

$$C = rV_\phi$$

$$C \approx (2.64 \times 10^7 \text{ ft})(2.9 \times 10^4 \text{ ft/sec})$$

$$\approx 7.65 \times 10^{11} \frac{\text{ft}^2}{\text{sec}}$$

$$\frac{1}{r} = \frac{GM}{C^2} + D \cos(\phi)$$

Note. $GM \approx 14.3 \times 10^{15} \frac{\text{lb-ft}^2}{\text{slug}}$

The constant D may be evaluated from the boundary conditions. At insertion the vehicle is traveling parallel to the surface of the Earth. At this point its reference angle ϕ is zero. Thus:

$$D = \frac{1}{r_0} - \frac{GM}{C^2} \approx 1.34 \times 10^{-7} \text{ ft}^{-1}$$

Substituting the constants, we obtain:

$$\frac{1}{r} \approx 2.44 \times 10^{-8} + [1.34 \times 10^{-8}] \cos(\phi)$$

The trajectory may be determined by evaluating r for varying ϕ . The results are given in Figure 1.

APPENDIX A Page A-4

The survey has revealed many effects the surface model must analogue. First, the net force provided by contact with the surface should be proportional to the inverse square of its radial coordinate. Secondly, it is necessary that angular momentum be conserved as the ball rolls around the surface. In Figure 3 the coordinate system employed is one in which the equation defining the surface of revolution can be readily developed. The distance \bar{r} is the distance from the point of origin to the location of the ball (projected into the x - z plane). Thus \bar{r} is always perpendicular to Y . The unit vector \hat{r} defines this direction. The unit vector $\hat{\phi}$ is in the direction of an increasing reference angle in the x - z plane. In Figure 4 we see the ball rolling on the surface of revolution. In the same diagram we see that gravity and the normal force on the ball are the only forces present, assuming that friction and windage are negligible. The differential equation of motion for the ball is:

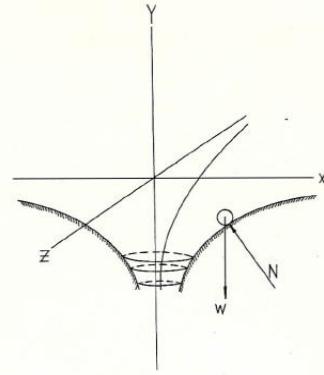
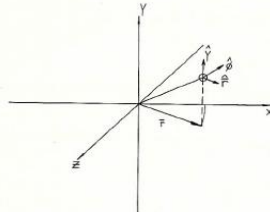

FIG-IV

The only remaining r term is therefore the centripetal acceleration. The equation may now be written

$$N_r = m \frac{V^2}{r}$$

In Figure 5 the free body diagram is presented for the special case of a circular orbit. We can see from this diagram the following:

$$\sin \theta = \frac{N_r}{N} \quad \cos \theta = \frac{N_y}{N}$$

$$N_r = (N) \sin \theta = \left(\frac{N_y}{\cos \theta} \right) \sin \theta$$

$$N_r = mg \tan \theta$$

$$N_r = mg \frac{dY}{d\bar{r}}$$

We have found that

$$N_r = m \frac{V^2}{\bar{r}}$$

$$m \frac{V^2}{\bar{r}} = mg \frac{dY}{d\bar{r}}$$

$$\boxed{\frac{dY}{d\bar{r}} = \frac{V^2}{\bar{r}g}}$$

Eq. 7

Banking formula

The above formula defines the angle the surface of revolution must be banked at in order to maintain a circular orbit with the ball rolling at a given radius and velocity.

In actual planetary motion the velocity required to maintain a circular orbit is:

$$V = \sqrt{\frac{K}{\bar{r}}} \quad \text{Eq. 8}$$

For the problem of a satellite in an Earth orbit the value of K will equal GM . For our surface the value of K will depend on our selected scale factors. If we substitute Eq. 8 into the banking formula, Eq. 7 an expression will result which describes the slope of the gravity model at every radius. Thus:

$$m[(\ddot{\bar{r}} - \dot{\bar{r}}\dot{\phi}^2)\hat{r} + (\ddot{\bar{r}}\dot{\phi} + 2\dot{\bar{r}}\ddot{\phi})\hat{\phi} + (\ddot{Y})\hat{Y}] = \mathbf{N} + m\mathbf{g} \quad \text{Eq. 5}$$

The normal force \mathbf{N} has two components

$$\mathbf{N} = (N_r)\hat{r} + (N_y)\hat{Y} \quad \text{Eq. 6}$$

N_r will always be negative as it is this force which is analogous to planetary attraction. Substituting Eq. 6 into Eq. 5,

$$m[(\ddot{\bar{r}} - \dot{\bar{r}}\dot{\phi}^2)\hat{r} + (\ddot{\bar{r}}\dot{\phi} + 2\dot{\bar{r}}\ddot{\phi})\hat{\phi} + (\ddot{Y})\hat{Y}] = (N_r)\hat{r} + (N_y - mg)\hat{Y}$$

The above expression can be simplified by restricting its use to a circular orbit. When a circular orbit is assumed the following terms drop out:

$\ddot{\bar{r}}$ the outward acceleration of the ball in the unit vector \hat{r} direction.

\ddot{Y} will drop out because the motion is planar, parallel to the x - z plane. It has also been implied that tangential and Coriolis accelerations were zero, leaving

$$m[(-\dot{\bar{r}}\dot{\phi}^2)\hat{r}] = (N_r)\hat{r} + (N_y - mg)\hat{Y}$$

It is then evident that for a circular orbit the following is true:

$$N_y = mg$$

$$N_r = -m\dot{\bar{r}}\dot{\phi}^2$$

APPENDIX A Page A-5

$$\frac{dY}{d\bar{r}} = \frac{V^2}{\bar{r}g} = \frac{K}{\bar{r}^2g}$$

Define $C_s = \frac{K}{g}$ as the surface constant. Integration yields the surface function

$$Y = C_s \int \frac{d\bar{r}}{\bar{r}^2} = -\frac{C_s}{\bar{r}} + C_1$$

The surface function, by defining the elevation of a point on the surface (and thus the ball at that point) also implies the potential energy of the ball.

If the zero of potential energy is taken at an infinite radius, the constant $C_1 = 0$. This is what is conventionally done in defining planetary and electrostatic potential energy. In this way the potential energy is a maximum at an infinite radius, and becomes increasingly negative (smaller) as the radius decreases. The surface function is now in the established reference:

$$Y = -\frac{C_s}{\bar{r}} \tag{Eq. 9}$$

In order to build a useful model, it is necessary to determine the value of the constant C_s . The actual velocity of a satellite in a circular orbit about a planet of mass M is given by:

$$V_s = \sqrt{\frac{GM}{r_s}} \tag{Eq. 10}$$

We have specified that the velocity of a ball in a circular orbit on the surface must vary in accordance with:

$$V_B = \sqrt{\frac{K}{\bar{r}_B}} \tag{Eq. 11}$$

We can define the velocity and radial scale factors as follows.

$$(VSF) = \frac{V_s}{V_B}$$

$$(RSF) = \frac{r_s}{\bar{r}_B}$$

Squaring Eqs. 10 and 11 and divide,

$$\frac{V_s^2}{V_B^2} = (VSF)^2 = \frac{GM}{K(RSF)}$$

Solving for K ,

$$K = \frac{GM}{(VSF)^2(RSF)}$$

Once convenient scale factors have been selected, the value of K can be determined. The value of C is given by:

$$C_s = \frac{K}{g}$$

The surface can now be constructed. If we wished to analogue the Earth's gravitational field out to a distance of 10,000 miles from the center of the Earth, we could do it in the following way. First select scale factors for velocity and space. Let us represent every 1000 miles by one foot on the model. The radial scale factor is then,

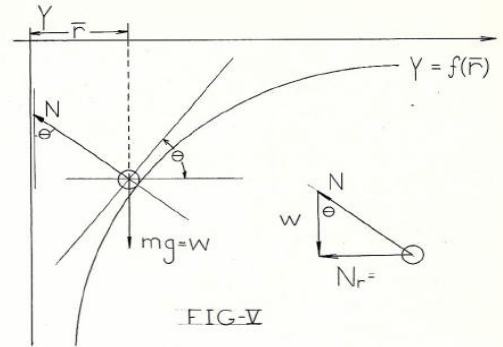

FIG-V

$$(RSF) = 5.28 \times 10^6 \frac{\text{ft}}{\text{ft}}$$

If we desired to analogue gravity at a radial distance of 10,000 miles it would require a model 10 feet in radius. The next step would be the selection of a convenient velocity scale factor. If a value of 2.07×10^3 the value of K can be determined.

$$K = \frac{GM}{(VSF)^2(RSF)} \approx 6.31 \times 10^2$$

$$C_s = \frac{K}{g} \approx 19.6$$

A plot of the potential surface is shown in Graph 2. It should be noted that the surface function varies in the same manner in which gravitational and electrostatic potential energy do. This is significant because it shows that the surface is a conceptual model of the gravitational field (potential energy).

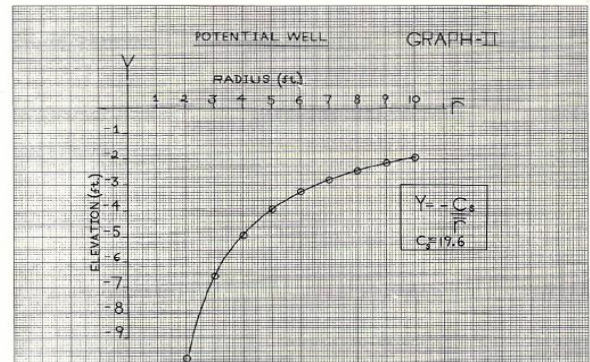

The actual construction of such a model presents some difficulties. Frictional forces, for example, could only be reduced by coating the surface with teflon. A more difficult problem is related to the coupling of the ball's spin with its motion around the central hole. We would, of course, desire that the energy appear only in the forms of gravitational potential and translational kinetic energy

APPENDIX A Page A-6

($\frac{1}{2}mv^2$). In actuality the ball possesses rotational kinetic energy as well ($\frac{1}{2}I\omega^2$). Substituting the moment of inertia of a solid sphere (about its own center) in terms of parameters convenient, the rotational kinetic energy can be written,

$$KE_R = \frac{1}{2} \left(\frac{2}{5}mR^2 \right) \frac{V^2}{R^2} = \frac{1}{5}mv^2$$

The total kinetic energy of the ball is thus:

$$KE_T = KE_L + KE_R = \frac{7}{10}mv^2$$

This problem could be partially eliminated by constructing the sphere with a dense core of small radius as compared with the outer radius of the ball (thus reducing the sphere's moment of inertia). If the surface were constructed of large enough dimensions so that its surface curvature did not interfere with the use of an air puck, the problem could be effectively eliminated. Linear kinetic energy would interchange with potential energy as the air puck accelerated down the potential well and then swung around at perigee to climb again to maximum potential energy.

Because of the difficulties involved in the construction (and use) of such a model, it presently serves only as a conceptual model of a gravity field.

BIBLIOGRAPHY

- Irving H. Shames, *Engineering Mechanics*. Prentice-Hall, Inc., 1960.
 Stephenson, *Mechanics and Properties of Matter*. John Wiley & Sons, Inc., 1960.

BIO-MEDICAL TELEMETRY

Valuable information may be found from the recording of brain waves. Up to the recent past, such recordings involved elaborate sensing equipment with the patient confined during such tests.

The availability of small transistors with low power supply requirements has rendered telemetry of the electro-encephalograph feasible. A miniaturized transmitter consisting of three transistors, a battery and associated passive components has been designed under contract by Dr. E. Wantuch with the Rockland State Mental Hospital of Orangeburg, New York.

Two electrodes separated by approximately $\frac{1}{2}$ " are located on the skull and contact is made by means of a conductive paste. Typical signal voltages are 10 microvolts over a frequency range of 0.1 to 30 Hz.

Operating with a carrier frequency of approximately 100 MHz, the desired information appears as frequency modulation of the carrier. This signal was received with a modified, commercial F-M tuner.

Since the immediate application involved patients confined to a restricted area, a transmitter range of 25 feet was satisfactory. The power drain from the 1.5 V battery was approximately 1 ma, thus producing an operating life of one week with a battery only $\frac{1}{2}$ " in diameter and $\frac{1}{8}$ " high.

The entire transmitter is shown in the accompanying photograph.

The assistance of Dr. W. Schick and Mr. A. Schielke is gratefully acknowledged.

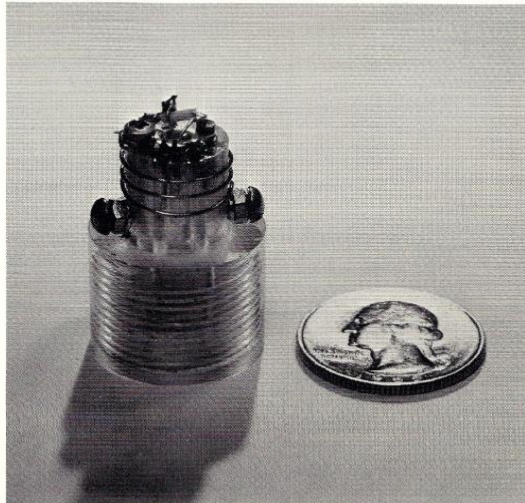

INTRODUCTION TO GRAVITY-WELL MODELS OF CELESTIAL OBJECTS

SAMPLER APPENDIX B Page B-1

Examples of Computer Images Generated by "TIME-HIST" Orbital Prediction Program – WWW.SPACEANIMATIONS.ORG

140 MILE CIRCULAR ORBIT OF THE EARTH INCLINED AT 30 DEGREES

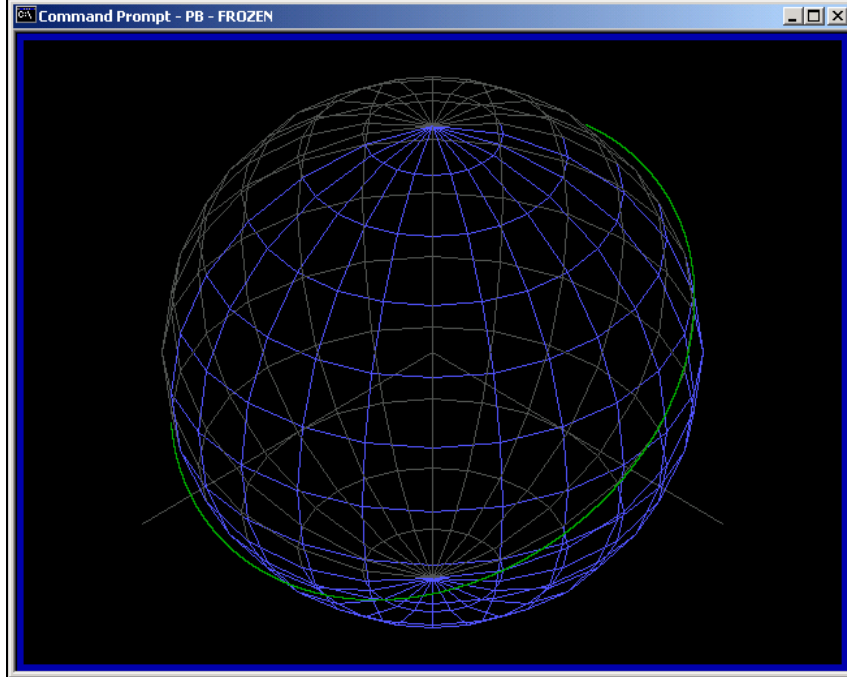

CIRCULAR ORBIT OF EARTH INCLINED AT 30 DEGREES TO THE EQUATOR
<http://www.spaceanimations.org/orbit6.htm>

HIGHLY ECCENTRIC ELLIPTICAL EQUATORIAL ORBIT OF THE EARTH

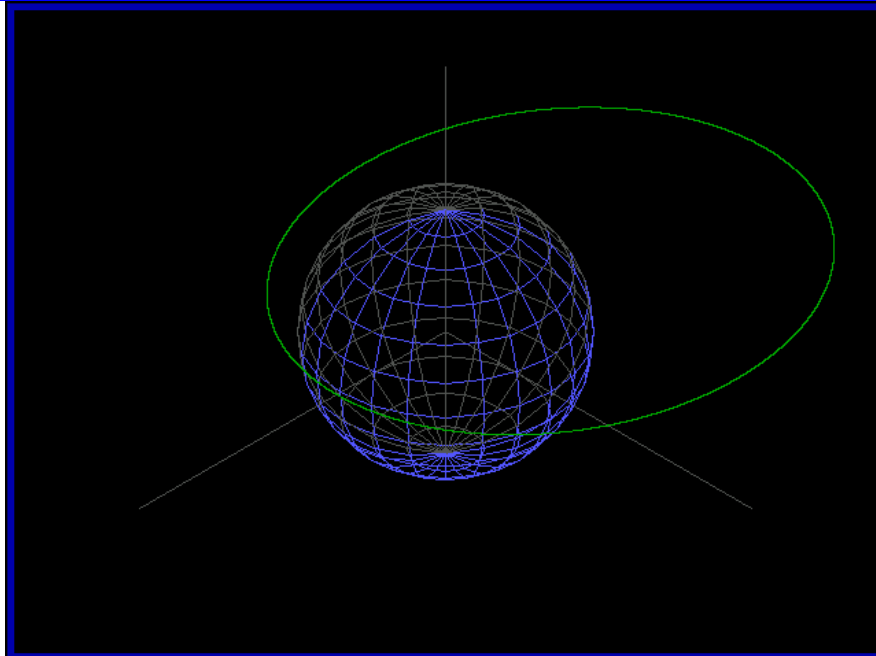

ECCENTRIC EQUATORIAL ORBIT
(4,100 MILES BY 12,000 MILES PERIGEE TO APOGEE RADIUS)

Friction and the Influence of Spin and Rotational Inertia on Gravity-Well Motions

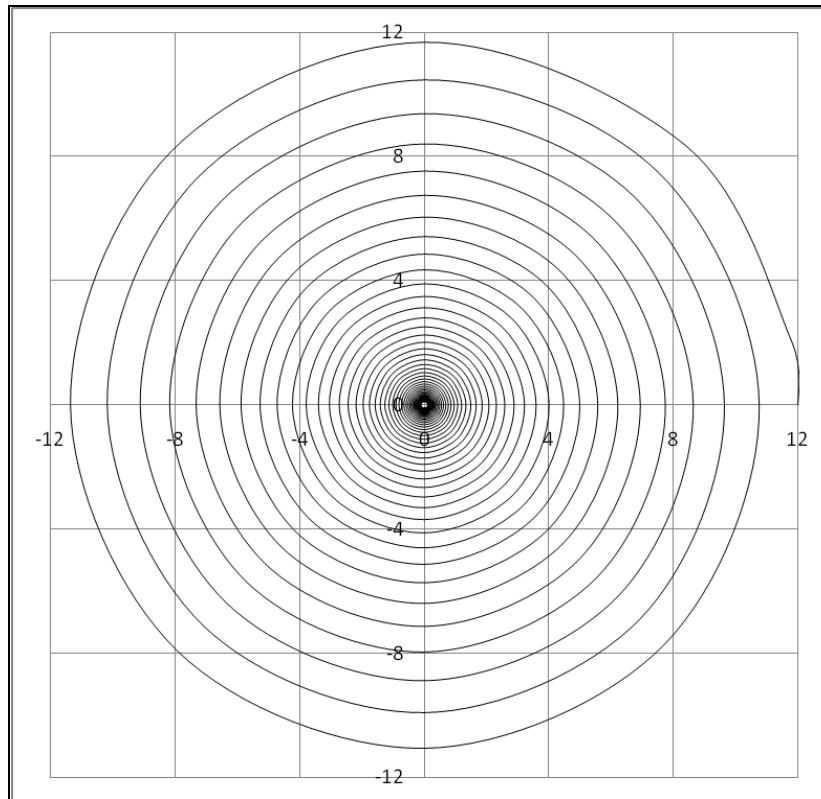

Influence of Rolling Friction on an Initially Circular Orbit Depicted by a Log Spiral on a 24" Diameter Gravity-Well Orbit (i.e., Initial Insert Radius of 12")

As demonstrated on actual gravity-well models, friction has an obvious visual effect on orbital motions. As shown above, a ball projected into an initially circular orbit will spiral in and decay. This fact is demonstrated on all gravity-wells whose surfaces are usually coated with Teflon, Gelcoat, or some other low friction finish. Depending on the cleanliness of the surfaces, complete decay can take between thirty to ninety seconds on smaller 24" or 36" diameter wells, to over two minutes on 6 foot and larger diameter wells, ultimately permitting the ball to drop down the central hole.

The above log spiral trajectory has been assigned a low friction coefficient, corresponding to a rigid metallic ball rolling on a structurally "hard" surface. Note that in this context, hardness is defined as surface resistance to distortion by a rigid sphere. If an "air puck" or hockey table approach is used to "lubricate" the well surface, the author believes the *decay rate* of the orbit may be significantly reduced, extending the total time for the puck to spiral into the central hole. More significantly, the air puck approach would totally eliminate spin effects such as rotational kinetic energy and gyroscopic inertia from producing errors in the simulated orbit. This approach may be investigated by inventors, or the technical staff of museums or planetariums that may be interested in what I believe may be a unique and very enjoyable science exhibit.

APPENDIX C Page C-2

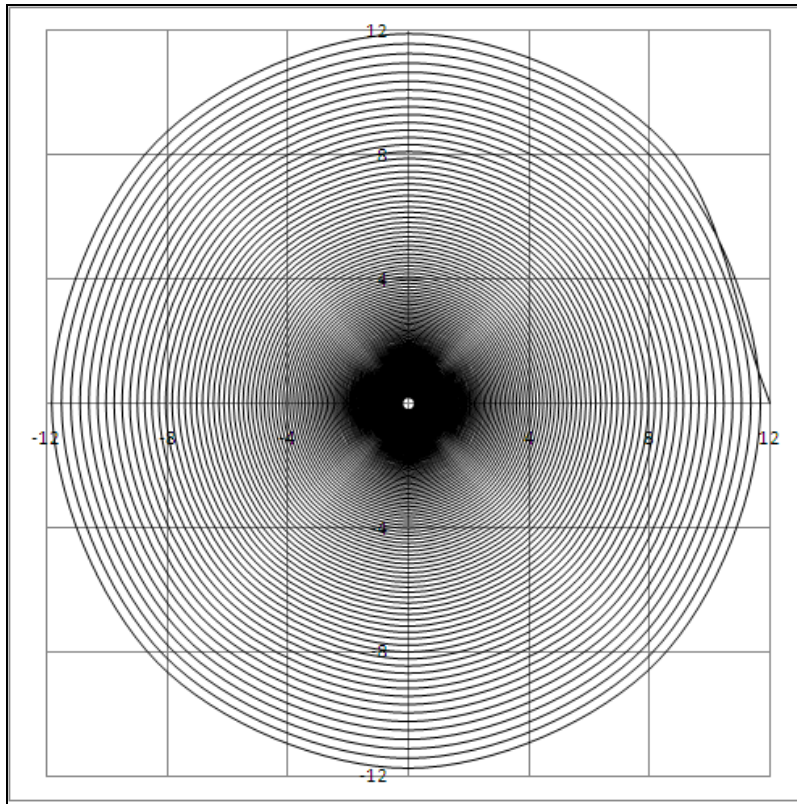

Reduced Influence of Friction on an Initially Circular Orbit Depicted by Possible Use of an Air Puck or Lubricating Bleed Air Holes on a 24" Diameter Gravity-Well (i.e., Initial Insert Radius of Orbit=12")

An air puck would take the place of the rolling ball and would look like a small flat disk made from aluminum less than $\frac{1}{4}$ " thick and 2" in diameter and would permit a thin pressurized layer of air to form and lubricate the surface beneath it. Such a measure is anticipated to result in somewhat reduced rate of decay orbits, similar to, or possibly better than the above figure in which the *differences* between a larger number of immediately adjacent orbits may be indistinguishable to the eye. This would produce a more realistic display to the casual observer. This approach would, of course, have to be tested, verified and optimized. Then the puck could be made to look more like a planet.

Should room temperature superconductivity ever be achieved the possibility of some form of magnetic levitation has also been considered. While surface friction can be virtually "eliminated", there would still be some slight orbital decay due to the air resistance on the orbiting item called *windage*, and the limited evacuation of some portion of the air from a pressure tight Lexan hemisphere (above the well surface to create a partial vacuum) would be a tricky proposition at best. Currently, these two approaches used in combination would likely be impractical for some time to come, and be revisited when advances in technology may make these measures economically and technically feasible.

Insights on the Longevity and Fidelity of Orbits on the Gravity-Well Model

Based on my own observations and experiences working with a number of gravity-wells, I can offer the following advice to experimenters on installation. Note that the respective commercial gravity-well vendors should always be contacted for their assistance and technical support regarding their wells.

- 1) *The first thing one must do when installing a gravity-well is level it, and find some means of marking the well for easy re-leveling with an inclinometer.* A simple carpenter's level can be used to level any two mutually perpendicular edges, like the front and side edges. If the well is off-level this will affect the contours of equal potential energy along the well surface. Threaded adjustable leveling feet are commercially available, inexpensive, and suggested for fine leveling adjustments. In addition to adjustable feet, two inclinometers permanently installed along the leveling edges will also prove helpful for periodic adjustments, and are currently available for only a few dollars.
 - a. An unlevelled gravity-well will have non-circular and roughly elliptical contours of equal elevation and a well which is *several* degrees out of the horizontal will have lines of equal-potential unsuitable for a single gravitating body. These will resemble those around the Moon due to the influence of the Earth (appearing below and reproduced from Figure 18 on page 54).

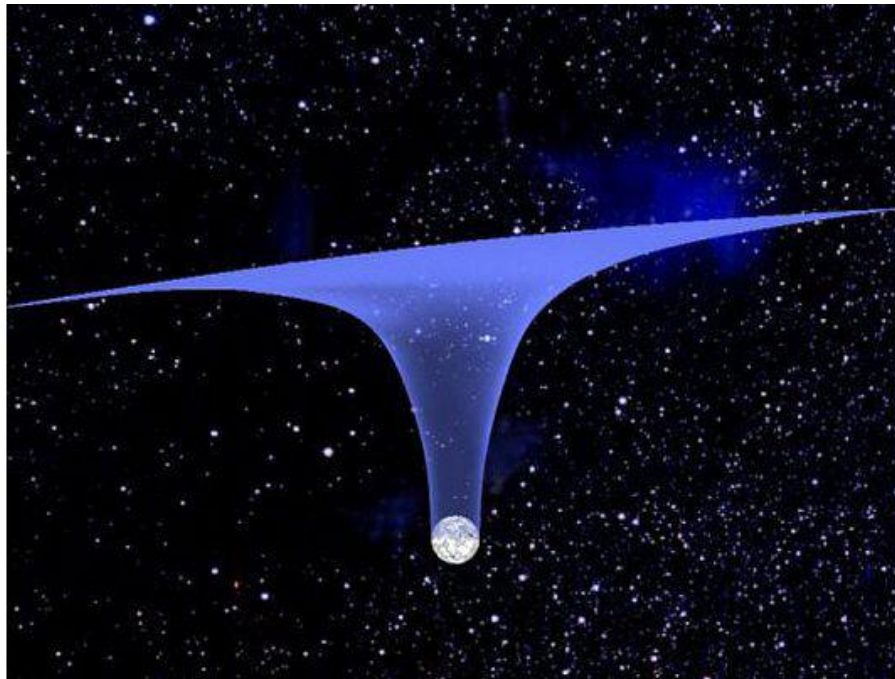

The Inclined Gravity-Well of the Earth-Moon System

Influence of the Earth Appears Related to an “Inclined” Gravity-Well
Lines of Constant Elevation Potential Will Appear Similar on Tilted Well

APPENDIX C Page C-4

- 2) **Once leveled and marked, immobilize the gravity-well as securely as practicable.** When using the well for scientific measurements this is obviously important, and can be done by bracing or adding stiffness to the well structural supports. While stable bases are provided by well vendors for relatively light objects, extra stability can be provided for more massive objects by securing the rear of the well to an adjacent wall using anchors. This bracing is especially easy for a well similar to www.spiralwishingwells.com design because of the *flat back edge* provided. If the well is not rigidly immobilized it will respond to the influence of centrifugal forces on the ball and will move and *slightly wobble* (like the suns of unseen companion stars). In their day the very early museum gravity-wells of the type featured at the Hayden and Boston Museum of Science were significantly more *massive* and rigid and thus less subject to this potential “wobble” problem than more current cost effective models.
- a. The greater size and mass of these museum exhibits tends to immobilize wells and produce orbits of greater longevity and fidelity for massive balls. However, the newer and lighter cost effective gravity-wells can be **structurally immobilized** by various other simple means.
 - b. The center of a star or planet is often mathematically treated as a stationary or “inertial frame of reference”. The fidelity of Keplerian like motions will be improved by securing gravity-wells as rigidly as possible, to prevent gross movements of the well. Any structure with mass and stiffness containing an accelerating mass (*i.e., the orbiting ball*) is subject to small vibration inputs and some periodic mechanical response, and an operating gravity well is no different.
 - c. The fiberglass gravity-well offered by vendors is well suited for this application as this material is inherently rigid and the surface is stiffened by its double curvature. This rigidity will help prevent local surface deflections at the moving point of support of the rolling ball, reducing friction and preventing gross translations of the well.
- 3) **The mass and inertia of the ball projected along the gravity-well will play a significant role in the longevity of the balls motions,** as I have determined empirically that the larger and more massive the ball, the greater the duration of the orbit. This is supported by the use of the *larger* ball bearings by the Hayden Planetarium, Boston Museum of Science and the Science Museum of Virginia for their very fine gravity-well exhibits.

APPENDIX C Page C-5

- a. In this regard, I have also tested a range of steel ball bearings of various diameters ranging from 1/4" diameter to the larger and more massive 1-1/4" diameter and found that the larger size balls produce moderately greater duration and somewhat higher fidelity orbits. During testing I found that the optimum for a 36" well was between 1" and 1-1/4" diameter balls for the longest duration orbit, owing to slight movements of my test well.
 - b. I also experimented with lighter 1 inch diameter solid glass spheres (i.e., marbles) as well as one inch diameter solid rubber balls. However, the larger steel balls always appeared to work best. This may be due to the relatively poor precision of a glass marble as well as their smaller density and mass. As one might expect, the orbits of light rubber balls decayed quickly and are useful for demonstrating the rapid orbital decay effects of friction, corresponding to air resistance.
 - c. The larger the size of the steel ball, the greater the mass (for the fixed density 0.28 lbs per cubic inch of steel) and the quantity of stored kinetic energy at a given speed. Also, according to the rules of rolling friction, friction force is *reduced* for larger *diameter* ball bearings. Less significant energy losses are consumed by rolling friction for larger balls. Since the reaction force "normal" to the well surface also varies with the mass and weight of the ball, this benefit will be only be slowly accrued with greater size, but generally speaking, the larger diameter steel balls produce a longer and more accurate orbit until well movements become a problem. This can be influenced by the tolerances of the ball bearings and any inaccurate spherical shaping would be detrimental to rolling true and the resulting orbit.
 - d. Note that the above result assumes that the gravity-well surface is itself *structurally rigid and immobilized* against any possible deflection. Otherwise, more massive balls will tend to produce greater local deformation at the moving point of support on the well surface, resulting in somewhat greater rolling friction.
- 4) *The coupling of the balls spin to its linear velocity is not desirable for high orbital fidelity* as at higher speeds the ball will possess (in addition to spin angular momentum and rotational kinetic energy) some gyroscopic inertia which also has no analogue in orbital mechanics.
- a. Such gyroscopic effects are believed to only detract from the fidelity of orbital motions and produce disturbing perturbations. *However, it is possible that longer duration orbits will be produced by gyroscopic effects, providing a more interesting exhibit for general public viewing.*

APPENDIX C Page C-6

- 5) The use of an air puck, table hockey bleed air design or possible magnetic levitation would effectively eliminate surface friction and decouple the spin of orbiting objects from meaningful linear motions.
- 6) Frictional surface effects are not always undesirable. For example, if one wished to demonstrate the natural decay of a satellite orbit once it encounters the tenuous atmosphere, it is possible to illustrate orbital braking using increased friction surface materials. If this more rapid spiraling effect is desired, it is an easy matter to increase the local surface friction coefficient by application of some anti-skid material to the well surface, providing greater traction.
- 7) The cleanliness of the well surface and an oil free ball are very important, and cannot be overemphasized. Obviously, ball bearings get dirty with handling and have imperfections on their surface. Balls tend to “jump” when they hit these imperfections, slowing them down and allowing test balls to suddenly and audibly *skid* down the well. I would also suggest that a very clean or polished ball will roll longer than one that has been handled and has various degrees of oils, contaminants and fingerprints on it. I have used various cleaning agents and found that *liquid* car cleaners work very well, while any *paste* like rubbing compound should be used only for refinishing a damaged well surface.
- 8) An adjustable but rigid curved launching ramp is very effective for providing the desired initial rolling conditions for the ball. Vendors of coin donation wells provide these ramps, which can be modified for ball bearings, or dedicated ball ramps can be constructed from “scratch” using a curved bicycle fender, or any similarly shaped item that may be available. The use of this ramp enables one, with proper selection of initial height and ramp terminal direction to find a combination that provides the desired initial velocity and orbit. This helps produce repeatable orbits for study. The roulette like rim of the well is also available for flinging the ball to start it off on a near perfect circular orbit. It is also informative to note when the ball breaks away from the rim and starts to make its slow descent once its speed and centrifugal force can no longer maintain that outer orbit.

INTRODUCTION TO GRAVITY-WELL MODELS OF CELESTIAL OBJECTS



Keith Mirenberg at Cyberchron Corporation in Cold Spring, New York

My personal research to support the writing of this book has employed early observations of orbital motions produced on several previously cited museum and planetarium gravity-wells, as well as two gravity-wells on which I was able to perform motion measurements and strobe light photography. These two wells were generously provided by www.spiralwishingwells.com and Hyperbolicfunnel.com in support of research efforts, and are shown below using one inch diameter ball bearings rolling along their surfaces.



Hyperbolicfunnel.com



www.spiralwishingwells.com

I have also employed the World Wide Web to support research by always searching for technical consensus between the various web sites. I do believe that the web can be productively employed for research by handling the information obtained from any particular web site as one would examine a single observation during experiments. This must be verified by additional testing and further searching on the web for corroboration, and *not* only be used when the information obtained supports ones pet purpose, favorite theory or agenda.

I do *not* agree with the proposition that the web should *never* be used to support research. I believe this was the original purpose of the web. In any case, I would think that the **technical content** of the World Wide Web is somewhat less subject to corruption by scoundrels and hoaxers. Notwithstanding, by using suitable methods of cross checking, personal inquiry and reflection, one can hopefully separate the “signal from the noise” contained in technical information available on the web. I wish the web were available during my early years when I was an engineering student, and am very glad for its current availability to us all.

INTRODUCTION TO GRAVITY-WELL MODELS OF CELESTIAL OBJECTS



Keith J. Mirenberg, PE

“Beyond the Event Horizon: Gravity-Well Models of Celestial Objects” was written by Keith J. Mirenberg who is an engineering consultant for Gibbs & Cox, (G&C) Inc. in New York, where he works in the fields of mechanical shock, vibration and noise control engineering. In addition, Keith has an interest in astronomy, cosmology, orbital mechanics, and computer graphics. He enjoys the challenge of summarizing a large quantity of technical but tedious numerical data into an attractive illustration using computer graphics. He has written this book which attempts to provide visual insights to gravitation by employing math models and computer generated images. On rare and fortunate occasions, the resulting figures might be considered “techno-art”, many of which appear on www.spaceanimations.org, his web site.

The origins of this book go back to 1967 when as a young engineering student Keith first saw a working *gravity-well* model while walking through the original Hayden Planetarium. This reproduced planetary like motions employing steel ball bearings rolling on a hard curved surface representing the gravity field. At the time he wondered what equations were used to generate this surface. The problem instantly caught his interest and without realizing it, he took the puzzle home to ponder obsessively and solve. This and related studies continued intermittently for years, culminating in this book. His first article on the gravity-well was published in 1968 in the Student Science Journal of Fairleigh Dickinson University, SPECTRA.



Boston Museum of Science-1980

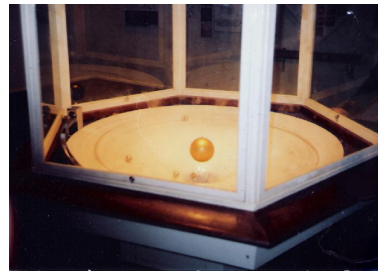

New York's Hayden Planetarium-1967

Keith has written articles on several subjects including noise field prediction, rocket propulsion, orbital mechanics, and natural and artificial gravity fields. He has also written noise prediction programs for twenty odd years at G&C. He has over thirty years of experience in the related areas of mechanical shock, vibration and noise control and also acquired a broad engineering background working for a number of organizations including: Pratt & Whitney Aircraft predicting gas turbine performance and jet exhaust noise, Boeing during the Apollo program, Combustion Engineering on reactor seismic analysis, Cyberchron Corporation on shock and vibration isolation systems, GEA Westfalia Separator Inc., where he worked on equipment dynamic characteristics, and Lane Engineering where he performed architectural noise control for various projects in the tri-state area. He is a 1968 BSME from FDU located in Teaneck New Jersey, and studied graduate level orbital mechanics and aerospace propulsion systems at the University of Connecticut. He earned his professional engineering license in Connecticut in 1978, and acquired a New York professional engineering license in 2002. While working as a PE in the tri-state area he has worked on various community noise projects, highway and rail noise, and housing noise controls. He also enjoyed working part time as an adjunct faculty member instructing professional engineering review courses at the Hartford Graduate Center of RPI in Hartford Connecticut for almost a decade (now known as Rensselaer at Hartford).