

OP 1280

(FIRST REVISION)

AIRCRAFT BOMBS



30 August 1955



DEPARTMENT OF THE NAVY
BUREAU OF ORDNANCE
WASHINGTON 25, D. C.

30 August 1955

CONFIDENTIAL

ORDNANCE PAMPHLET 1280 (FIRST REVISION)

AIRCRAFT BOMBS

1. Ordnance Pamphlet 1280 (First Revision) describes aircraft bombs in current use, and contains instructions for their flight preparation.
2. This publication is intended for use by all personnel concerned with tactical use of aircraft bombs and associated equipment.
3. This publication supersedes OP 878 (Second Revision), OP 1280, dated 17 February 1945, and OTI AV3-45, which should be destroyed by burning.
4. It is not intended that this publication be carried in aircraft for use therein.
5. This publication is CONFIDENTIAL and shall be safeguarded in accordance with the security provisions of U. S. Navy Regulations and the provisions of applicable Federal Statutes and Executive Orders summarized in the Department of Defense Industrial Security Manual for Safeguarding Classified Information. As stated in Article 0906.2 of OPNAVINST 5510.1A, dated 2 October 1954, it is forbidden to make extracts from or to copy this classified document without authorization.

A handwritten signature in black ink, reading "F. S. Withington", is positioned above the typed name and title.

F. S. WITHINGTON,
Rear Admiral, U. S. Navy
Chief, Bureau of Ordnance

CONFIDENTIAL

CONFIDENTIAL

NAVY DEPARTMENT
BUREAU OF ORDNANCE
WASHINGTON 25, D.C.

To all holders of ORDNANCE PAMPHLET 1280 (FIRST REVISION)
insert change; write on cover 'Change 1 inserted'
Approved by The Chief of the Bureau of Ordnance

OP 1280 (1st Rev) **CHANGE 1**

Assistant Director, Research Division

1 Page _____ Page 1
(with enclosures)
AIRCRAFT BOMBS

ORDNANCE PAMPHLET 1280 (FIRST REVISION)

is changed as follows:

1. Page iv, add "Section 11.9 - 250-1b Practice Bomb Mk 86 Mod 0 - - - 222a".
2. Page viii, add
"11.23 - 250-1b Practice Bomb Mk 86 Mod 0 - - - - - 222a
11.24 - 250-1b Practice Bomb Mk 86 Mod 0, Exploded View - 222b
11.25 - 250-1b Practice Bomb Mk 86 Mod 0, Cutaway View - - 222d".
3. Page 191, add "Section 11.9 - 250-1b Practice Bomb Mk 86 Mod 0".
4. Page 193, add under Practice Bombs "250-1b Practice Bomb Mk 86 Mod 0".
5. Between pages 221-222 and 223-224, insert the attached new pages 222a, 222b, 222c, and 222d.
6. After the above corrections and additions have been completed, insert this CHANGE sheet in the front of the book, following the title page.

CONFIDENTIAL

CONTENTS

<i>Chapter</i>	<i>Page</i>
1. INTRODUCTION	3
Section 1.1—General	3
Section 1.2—Fuzes	8
Section 1.3—Arming Wires	10
Section 1.4—Packing	12
2. ARMOR-PIERCING BOMBS	19
Section 2.1—General	19
Section 2.2—1000-lb AP Bomb AN-Mk 33 and Mods	21
Section 2.3—1600-lb AP Bomb AN-Mk 1 and Mods	25
3. SEMI-ARMOR-PIERCING BOMBS	31
Section 3.1—General	31
Section 3.2—500-lb SAP Bombs AN-M58A2, AN-M58, and AN-M58A1	34
Section 3.3—1000-lb SAP Bombs AN-M59A1 and AN-M59	38
Section 3.4—2000-lb SAP Bomb M103	42
4. GENERAL PURPOSE BOMBS	47
Section 4.1—General	47
Section 4.2—100-lb GP Bomb AN-M30A1 with Fin Assembly AN-M103A1	50
Section 4.3—100-lb GP Bomb AN-M30A1 with Fin Assembly M135 (T144)	54
Section 4.4—250-lb GP Bomb AN-M57A1 with Fin Assembly AN-M106A1	56
Section 4.5—250-lb GP Bomb AN-M57A1 with Fin Assembly M126 (T147)	60
Section 4.6—500-lb GP Bomb AN-M64A1 with Fin Assembly AN-M109A1	62
Section 4.7—500-lb GP Bomb AN-M64A1 with Fin Assembly M128A1 (T127)	66
Section 4.8—1000-lb GP Bomb AN-M65A1 with Fin Assembly AN-M113A1	68
Section 4.9—1000-lb GP Bomb AN-M65A1 with Fin Assembly M129 (T142)	72
Section 4.10—2000-lb GP Bomb AN-M66A2 with Fin Assembly AN-M116A1	74
Section 4.11—2000-lb GP Bomb AN-M66A2 with Fin Assembly M130 (T143)	78
5. GENERAL PURPOSE BOMBS (LOW DRAG)	83
Section 5.1—General	83
Section 5.2—250-lb GP Bomb Mk 81 Mod 1	87
Section 5.3—500-lb GP Bomb Mk 82 Mods 0 and 1	91
Section 5.4—1000-lb GP Bomb Mk 83 Mods 2 and 3	95
Section 5.5—2000-lb GP Bomb Mk 84 Mod 1	100
6. FRAGMENTATION BOMBS	107
Section 6.1—General	107
Section 6.2—4-lb Fragmentation Bomb M83	109
Section 6.3—20-lb Fragmentation Bomb AN-M41A1	112
Section 6.4—90-lb Fragmentation Bomb M82	115
Section 6.5—220-lb Fragmentation Bomb AN-M88 with Fin Assembly AN-M103A1	118
Section 6.6—220-lb Fragmentation Bomb AN-M88 with Fin Assembly M135	122
Section 6.7—260-lb Fragmentation Bomb AN-M81 with Fin Assembly AN-M103A1	124
Section 6.8—260-lb Fragmentation Bomb AN-M81 with Fin Assembly M135	128

Chapter	Page
7. FRAGMENTATION BOMB CLUSTERS	133
Section 7.1—General	133
Section 7.2—100-lb Fragmentation Bomb Cluster AN-M1A2	135
Section 7.3—100-lb Fragmentation Bomb Cluster M28A2	139
Section 7.4—500-lb Fragmentation Bomb Cluster M26A2 (M26A1)	143
Section 7.5—500-lb Fragmentation Bomb Cluster M27A1	147
Section 7.6—500-lb Fragmentation Bomb Cluster M29A1	151
8. DEMOLITION BOMBS	159
Section 8.1—General	159
Section 8.2—750-lb Demolition Bomb M117	161
Section 8.3—3000-lb Demolition Bomb M118	165
9. AIRCRAFT DEPTH BOMBS	171
Section 9.1—General	171
Section 9.2—350-lb AD Bomb AN-Mk 54 Mods 0 and 1	173
10. MINIATURE PRACTICE BOMBS	179
Section 10.1—General	179
Section 10.2—3-lb MP Bomb Mk 5 Mods 0, 1, 2, and 3	181
3-lb MP Bomb AN-Mk 23 Mods 0 and 1	181
4.5-lb MP Bomb Mk 43 Mods 0 and 1	181
Section 10.3—13-lb MP Bomb Mk 19 Mods 0 and 1	186
11. PRACTICE BOMBS	193
Section 11.1—General	193
Section 11.2—25-lb Practice Bomb Mk 76 Mod 0	196
Section 11.3—100-lb Practice Bomb Mk 15 Mod 3	200
Section 11.4—100-lb Practice Bomb Mk 15 Mod 4	204
Section 11.5—500-lb Practice Bomb Mk 65 Mod 0	208
Section 11.6—1000-lb Practice Bomb Mk 66 Mod 0	211
Section 11.7—1000-lb Practice Bomb Mk 88 Mod 0	215
Section 11.8—2000-lb Practice Bomb Mk 67 Mod 0	219
12. FIRE BOMBS	225
Section 12.1—General	225
Section 12.2—750-lb Fire Bomb Mk 77 Mod 0	228
Section 12.3—750-lb Fire Bomb Mk 77 Mod 0 with Bomb Conversion Kit Mk 19 Mod 0	232
Section 12.4—500-lb Fire Bomb Mk 77 Mod 1	235
Section 12.5—750-lb Fire Bomb Mk 78 Mod 2	239
Section 12.6—1000-lb Fire Bomb Mk 79 Mod 0	243
Section 11.9 - 750-lb. Practice Bomb Mk 86 Mod 0 - - - 222d.	222d

"Section 11.10 - 56-lb Practice Bomb Mk 89 Mod 0 - - - - -	222e
Section 11.11 - 500-lb Practice Bomb Mk 87 Mod 0 - - - - -	222i
Section 11.12 - 25-lb Practice Bomb Mk 76 Mod 1 - - - - -	222m
Section 11.13 - 25-lb Practice Bomb Mk 76 Mod 2 - - - - -	222q
Section 11.14 - 25-lb Practice Bomb Mk 76 Mod 3 - - - - -	222u

ILLUSTRATIONS

<i>Figure</i>	<i>Page</i>
1.1 —Explosive Train.....	4
1.2 —Bombs Released “ARMED” and “UNARMED”.....	8
1.3 —Arming Wires.....	11
1.4 —Packing of Bombs.....	13
1.5 —Packing of Fins.....	14
1.6 —Packing of Arming Wires.....	15
2.1 —Armor-piercing Bombs, Comparative Size.....	19
2.2 —1000-lb AP Bomb AN-Mk 33.....	21
2.3 —1000-lb AP Bomb AN-Mk 33, Exploded View.....	22
2.4 —1000-lb AP Bomb AN-Mk 33, Cutaway View.....	23
2.5 —1600-lb AP Bomb AN-Mk 1.....	25
2.6 —1600-lb AP Bomb AN-Mk 1, Exploded View.....	26
2.7 —1600-lb AP Bomb AN-Mk 1, Cutaway View.....	27
3.1 —Semi-armor-piercing Bombs, Comparative Size.....	31
3.2 —500-lb SAP Bomb AN-M58A2.....	34
3.3 —500-lb SAP Bomb AN-M58A2, Exploded View.....	35
3.4 —500-lb SAP Bomb AN-M58A2, Cutaway View.....	37
3.5 —1000-lb SAP Bomb AN-M59A1.....	38
3.6 —1000-lb SAP Bomb AN-M59A1, Exploded View.....	39
3.7 —1000-lb SAP Bomb AN-M59A1, Cutaway View.....	41
3.8 —2000-lb SAP Bomb M103.....	42
3.9 —2000-lb SAP Bomb M103, Exploded View.....	43
3.10—2000-lb SAP Bomb M103, Cutaway View.....	44
4.1 —General Purpose Bombs, Comparative Size.....	48
4.2 —100-lb GP Bomb AN-M30A1 with Fin Assembly AN-M103A1.....	49
4.3 —100-lb GP Bomb AN-M30A1 with Fin Assembly AN-M103A1, Exploded View.....	50
4.4 —100-lb GP Bomb AN-M30A1 with Fin Assembly AN-M103A1, Cutaway View.....	53
4.5 —100-lb GP Bomb AN-M30A1 with Fin Assembly M135, Exploded View.....	54
4.6 —250-lb GP Bomb AN-M57A1 with Fin Assembly AN-M106A1.....	56
4.7 —250-lb GP Bomb AN-M57A1 with Fin Assembly AN-M106A1, Exploded View.....	57
4.8 —250-lb GP Bomb AN-M57A1 with Fin Assembly AN-M106A1, Cutaway View.....	58
4.9 —250-lb GP Bomb AN-M57A1 with Fin Assembly M126, Exploded View.....	60
4.10—500-lb GP Bomb AN-M64A1 with Fin Assembly AN-M109A1.....	62
4.11—500-lb GP Bomb AN-M64A1 with Fin Assembly AN-M109A1, Exploded View.....	63
4.12—500-lb GP Bomb AN-M64A1 with Fin Assembly AN-M109A1, Cutaway View.....	65
4.13—500-lb GP Bomb AN-M64A1 with Fin Assembly M128A1, Exploded View.....	66
4.14—1000-lb GP Bomb AN-M65A1 with Fin Assembly AN-M113A1.....	68
4.15—1000-lb GP Bomb AN-M65A1 with Fin Assembly AN-M113A1, Exploded View.....	69
4.16—1000-lb GP Bomb AN-M65A1 with Fin Assembly AN-M113A1, Cutaway View.....	70
4.17—1000-lb GP Bomb AN-M65A1 with Fin Assembly M129, Exploded View.....	72
4.18—2000-lb GP Bomb AN-M66A2 with Fin Assembly AN-M116A1.....	74
4.19—2000-lb GP Bomb AN-M66A2 with Fin Assembly AN-M116A1, Exploded View.....	75
4.20—2000-lb GP Bomb AN-M66A2 with Fin Assembly AN-M116A1, Cutaway View.....	76
4.21—2000-lb GP Bomb AN-M66A2 with Fin Assembly M130, Exploded View.....	78

<i>Figure</i>	<i>Page</i>
5.1a—Low-drag General Purpose Bombs (Electrically Fuzed), Comparative Size	84
5.1b—Low-drag General Purpose Bombs (Mechanically Fuzed), Comparative Size	85
5.2 —250-lb GP Bomb Mk 81 Mod 1 (Mechanically Fuzed)	87
5.3 —250-lb GP Bomb Mk 81 Mod 1 (Mechanically Fuzed), Exploded View	88
5.4 —250-lb GP Bomb Mk 81 Mod 1 (Mechanically Fuzed), Cutaway View	89
5.5 —500-lb GP Bomb Mk 82 Mod 0 (Mechanically Fuzed)	91
5.6 —500-lb GP Bomb Mk 82 Mod 0 (Mechanically Fuzed), Exploded View	92
5.7 —500-lb GP Bomb Mk 82 Mod 0 (Mechanically Fuzed), Cutaway View	93
5.8 —1000-lb GP Bomb Mk 83 Mod 2 (Mechanically Fuzed)	95
5.9 —1000-lb GP Bomb Mk 83 Mod 2 (Mechanically Fuzed), Exploded View	97
5.10—1000-lb GP Bomb Mk 83 Mod 2 (Mechanically Fuzed), Cutaway View	98
5.11—2000-lb GP Bomb Mk 84 Mod 1 (Mechanically Fuzed)	100
5.12—2000-lb GP Bomb Mk 84 Mod 1 (Mechanically Fuzed), Exploded View	101
5.13—2000-lb GP Bomb Mk 84 Mod 1 (Mechanically Fuzed), Cutaway View	102
6.1 —Fragmentation Bombs, Comparative Size	107
6.2 —4-lb Fragmentation Bomb M83	109
6.3 —4-lb Fragmentation Bomb M83 (Armed and Unarmed Positions)	111
6.4 —20-lb Fragmentation Bomb AN-M41A1	112
6.5 —20-lb Fragmentation Bomb AN-M41A1, Exploded View	113
6.6 —20-lb Fragmentation Bomb AN-M41A1, Cutaway View	114
6.7 —90-lb Fragmentation Bomb M82	115
6.8 —90-lb Fragmentation Bomb M82, Exploded View	116
6.9 —90-lb Fragmentation Bomb M82, Cutaway View	117
6.10—220-lb Fragmentation Bomb AN-M88 with Fin Assembly AN-M103A1	118
6.11—220-lb Fragmentation Bomb AN-M88 with Fin Assembly AN-M103A1, Exploded View	119
6.12—220-lb Fragmentation Bomb AN-M88 with Fin Assembly AN-M103A1, Cutaway View	121
6.13—220-lb Fragmentation Bomb AN-M88 with Fin Assembly M135, Exploded View	122
6.14—260-lb Fragmentation Bomb AN-M81 with Fin Assembly AN-M103A1	124
6.15—260-lb Fragmentation Bomb AN-M81 with Fin Assembly AN-M103A1, Exploded View	125
6.16—260-lb Fragmentation Bomb AN-M81 with Fin Assembly AN-M103A1, Cutaway View	127
6.17—260-lb Fragmentation Bomb AN-M81 with Fin Assembly AN-M135, Exploded View	129-130
7.1 —Cluster Adapter AN-M1A3	135
7.2 —100-lb Fragmentation Bomb Cluster AN-M1A2, Perspective View	136
7.3 —20-lb Fragmentation Bomb AN-M41A1	137
7.4 —100-lb Fragmentation Bomb Cluster M28A2	139
7.5 —100-lb Fragmentation Bomb Cluster M28A2, Cutaway View	140
7.6 —4-lb Fragmentation Bomb M83	141
7.7 —Cluster Adapter AN-M13A2	143
7.8 —500-lb Fragmentation Bomb Cluster M26A2, Perspective View	144
7.9 —20-lb Fragmentation Bomb AN-M41A1	145
7.10—Cluster Adapter M14A1	147
7.11—500-lb Fragmentation Bomb Cluster M27A1, Perspective View	148
7.12—90-lb Fragmentation Bomb M82	150

<i>Figure</i>	<i>Page</i>
7. 13—500-lb Fragmentation Bomb Cluster M29A1	151
7. 14—500-lb Fragmentation Bomb Cluster M29A1, Cutaway View	153
7. 15—4-lb Fragmentation Bomb M83 and Wafer	154
8. 1 —Demolition Bombs, Comparative Size	159
8. 2 —750-lb Demolition Bomb M117 (Mechanically Fuzed)	161
8. 3 —750-lb Demolition Bomb M117 (Mechanically Fuzed), Exploded View	162
8. 4 —750-lb Demolition Bomb M117 (Mechanically Fuzed), Cutaway View	164
8. 5 —3000-lb Demolition Bomb M118 (Mechanically Fuzed)	165
8. 6 —3000-lb Demolition Bomb M118 (Mechanically Fuzed), Exploded View	166
8. 7 —3000-lb Demolition Bomb M118 (Mechanically Fuzed), Cutaway View	167
9. 1 —350-lb Aircraft Depth Bomb AN-Mk 54 Mod 1	173
9. 2 —350-lb Aircraft Depth Bomb AN-Mk 54 Mod 1, Exploded View	174
9. 3 —350-lb Aircraft Depth Bomb AN-Mk 54 Mod 1, Cutaway View	176
10. 1 —Miniature Practice Bombs, Comparative Size	179
10. 2 —3-lb Miniature Practice Bomb AN-Mk 23 Mod 1	182
10. 3 —3-lb Miniature Practice Bomb AN-Mk 23 Mod 1, Exploded View	183
10. 4 —3-lb Miniature Practice Bomb AN-Mk 23 Mod 1, Cutaway View	185
10. 5 —13-lb Miniature Practice Bomb Mk 19 Mod 1	186
10. 6 —13-lb Miniature Practice Bomb Mk 19 Mod 1, Exploded View	187
10. 7 —13-lb Miniature Practice Bomb Mk 19 Mod 1, Cutaway View	189-190
11. 1 —Practice Bombs, Comparative Size	194
11. 2 —25-lb Practice Bomb Mk 76 Mod 0	196
11. 3 —25-lb Practice Bomb Mk 76 Mod 0, Exploded View	197
11. 4 —25-lb Practice Bomb Mk 76 Mod 0, Cutaway View	198
11. 5 —100-lb Practice Bomb Mk 15 Mod 3	200
11. 6 —100-lb Practice Bomb Mk 15 Mod 3, Exploded View	201
11. 7 —100-lb Practice Bomb Mk 15 Mod 3, Cutaway View	203
11. 8 —100-lb Practice Bomb Mk 15 Mod 4	204
11. 9 —100-lb Practice Bomb Mk 15 Mod 4, Exploded View	205
11. 10—100-lb Practice Bomb Mk 15 Mod 4, Cutaway View	207
11. 11—500-lb Practice Bomb Mk 65 Mod 0	208
11. 12—500-lb Practice Bomb Mk 65 Mod 0, Exploded View	209
11. 13—500-lb Practice Bomb Mk 65 Mod 0, Cutaway View	210
11. 14—1000-lb Practice Bomb Mk 66 Mod 0	211
11. 15—1000-lb Practice Bomb Mk 66 Mod 0, Exploded View	212
11. 16—1000-lb Practice Bomb Mk 66 Mod 0, Cutaway View	213
11. 17—1000-lb Practice Bomb Mk 88 Mod 0	215
11. 18—1000-lb Practice Bomb Mk 88 Mod 0, Exploded View	216
11. 19—1000-lb Practice Bomb Mk 88 Mod 0, Cutaway View	218
11. 20—2000-lb Practice Bomb Mk 67 Mod 0	219
11. 21—2000-lb Practice Bomb Mk 67 Mod 0, Exploded View	220
11. 22—2000-lb Practice Bomb Mk 67 Mod 0, Cutaway View	221-222
* 12. 1 —Fire Bombs, Comparative Size	226
12. 2 —750-lb Fire Bomb Mk 77 Mod 0	228
12. 3 —750-lb Fire Bomb Mk 77 Mod 0, Exploded View	229
12. 4 —750-lb Fire Bomb Mk 77 Mod 0, Cutaway View	230
12. 5 —750-lb Fire Bomb Mk 77 Mod 0 with Bomb Conversion Kit Mk 19 Mod 0, Exploded View	232

James V.

<i>Figure</i>	<i>Page</i>
12.6 —500-lb Fire Bomb Mk 77 Mod 1	235
12.7 —500-lb Fire Bomb Mk 77 Mod 1, Exploded View	236
12.8 —500-lb Fire Bomb Mk 77 Mod 1, Cutaway View	237
12.9 —750-lb Fire Bomb Mk 78 Mod 2	239
12.10—750-lb Fire Bomb Mk 78 Mod 2, Exploded View	240
12.11—750-lb Fire Bomb Mk 78 Mod 2, Cutaway View	241
12.12—1000-lb Fire Bomb Mk 79 Mod 0	243
12.13—1000-lb Fire Bomb Mk 79 Mod 0, Exploded View	244
12.14—1000-lb Fire Bomb Mk 79 Mod 0, Cutaway View	247
<i>11.23 250-lb. Practice Bomb Mk 86 Mod 0</i>	<i>222 A</i>
<i>11.24 250-lb Practice Bomb Mk 86 Mod 0, Exploded View</i>	<i>222 B</i>
<i>11.25 250-lb Practice Bomb Mk 86 Mod 0, Cutaway View</i>	<i>222 C</i>

see viii, add

11.26 - 56-lb Practice Bomb Mk 89 Mod 0	222e
11.27 - 56-lb Practice Bomb Mk 89 Mod 0, Exploded View	222f
11.28 - 56-lb Practice Bomb Mk 89 Mod 0, Cutaway View	222g
11.29 - 500-lb Practice Bomb Mk 87 Mod 0	222i
11.30 - 500-lb Practice Bomb Mk 87 Mod 0, Exploded View	222j
11.31 - 500-lb Practice Bomb Mk 87 Mod 0, Cutaway View	222k
11.32 - 25-lb Practice Bomb Mk 76 Mod 1	222m
11.33 - 25-lb Practice Bomb Mk 76 Mod 1, Exploded View	222n
11.34 - 25-lb Practice Bomb Mk 76 Mod 1, Cutaway View	222o
11.35 - 25-lb Practice Bomb Mk 76 Mod 2	222q
11.36 - 25-lb Practice Bomb Mk 76 Mod 2, Exploded View	222r
11.37 - 25-lb Practice Bomb Mk 76 Mod 2, Cutaway View	222s
11.38 - 25-lb Practice Bomb Mk 76 Mod 3	222u
11.39 - 25-lb Practice Bomb Mk 76 Mod 3, Exploded View	222v
11.40 - 25-lb Practice Bomb Mk 76 Mod 3, Cutaway View	222w

CONFIDENTIAL

Chapter 1

INTRODUCTION

Section 1.1—General

Section 1.2—Fuzes

Section 1.3—Arming Wires

Section 1.4—Packing

CONFIDENTIAL

Chapter 1

INTRODUCTION

Section 1.1—General

This publication describes aircraft bombs used by the Navy and the Air Force, and gives instructions for identifying, handling, and assembling these bombs. It also includes safety precautions, and physical characteristics (weight and measurements) and components of complete rounds in tabular form.

Detailed information concerning installation and the release of bombs from aircraft is not included herein.

The security classification of this publication is CONFIDENTIAL because of the information in chapter 5. All other chapters, however, contain only unclassified information.

Aircraft bombs are designed for release over enemy targets to reduce and neutralize their war potential by destructive explosion, fire, nuclear reaction, war gases, biological agents, and interdiction. They are used strategically to destroy installations, armament, and personnel, and tactically to provide direct support of our land and sea forces engaged in offensive or defensive operations.

A bomb usually consists of a body, stabilizer, and means of detonation. The body can be filled with either an explosive, chemical, biological, nuclear, or inert filler. Stabilizers are attached to the bomb body and may consist of sheet-metal fins, parachutes, or cloth streamers. The efficient destruction of the various types of enemy targets requires different types of bombs (fragmentation, blast, incendiary, armor-piercing, etc.).

A fundamental characteristic of the explosive charge of a bomb is its relative insensitivity to ordinary shock and heat incident to loading, transporting, handling, and storing. A three-fold advantage is gained by the use of insensitive explosives because they permit:

1. An adequate degree of safety for the using personnel, when the explosives are handled properly;

2. Maximum target damage by control of the bomb's detonation;

3. Bombs to be dropped "SAFE" from aircraft without exploding, in most instances.

Because of this insensitive characteristic, a fuze is used to provide a supersensitive explosive element and the action necessary for detonating it. The component of a fuze containing this supersensitive explosive is called the detonator. Shock created by the explosion of the detonator may not be strong enough to explode the less sensitive main charge of the bomb. An intermediate element then is required. This connecting link between the fuze detonator and the bomb's main charge is called the booster. It is small enough to be set off by the detonator, and large enough so that its shock will explode the main charge.

The detonator within the fuze is fired by mechanical or electrical action, and its explosion is amplified and relayed to the main charge by the booster. This pattern of action is called the explosive train, figure 1.1.

Types of Explosives

Various classifications of bombs use different types of explosives for maximum target destruction. When a high-explosive bomb is detonated, the charge is transformed, in an instant, into a very hot gas. This gas momentarily occupies only the volume of the solid explosive and develops enormous pressure. The gases then expand violently in all directions, shattering or displacing surrounding material. Shock and pressure waves are built up which throw fragments of the shattered case outward at a high

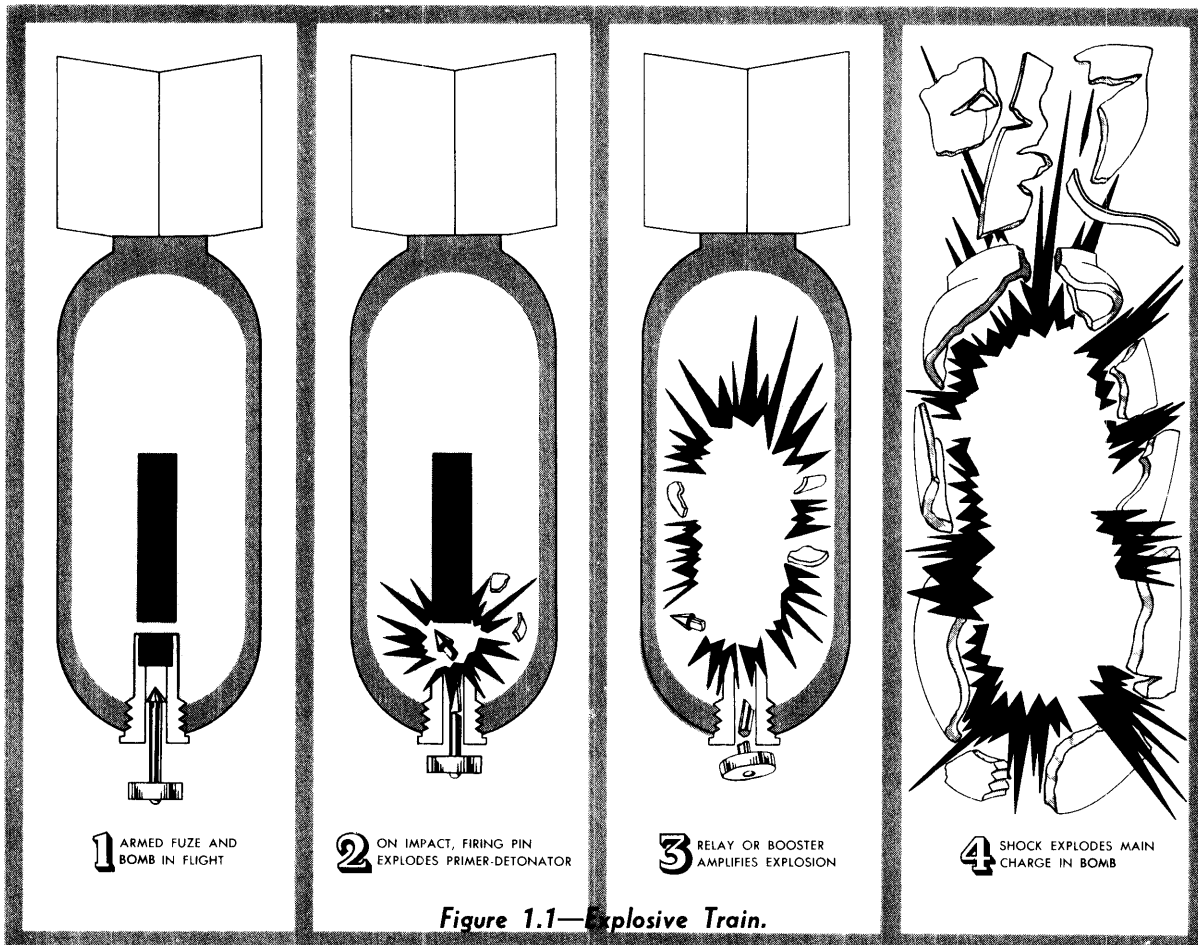

velocity. The high explosives used in bombs are:

TNT (Trinitrotoluene). Trinitrotoluene, commonly known as TNT, is a relatively insensitive high-explosive of great stability. It has been used as the main charge in general purpose bombs. In recent years, it has been superseded by more powerful explosives, such as Tritonal.

Amatol. Amatol, a mixture of ammonium nitrate and TNT, is less sensitive than TNT. When used in a 50/50 ratio, it has approximately the same rate of detonation and brisance (shattering ability) as TNT. It was used as a main charge in bombs prior to, and during, the early part of World War II.

Composition B. Composition B (Comp B) is a very powerful explosive, particularly from the fragmentation standpoint. It consists of

large percentages of RDX and TNT with a small amount of wax. The principal ingredient, RDX, is a powerful but sensitive explosive, and therefore always is used in mixtures with other materials. Composition B presently is used as the main filler in fragmentation bombs.

Explosive D (Ammonium picrate). Ammonium picrate is the least sensitive, of military explosives, to shock and friction. For this reason, it is used in armor-piercing bombs which must withstand severe shock and stresses before detonating.

Tritonal. Tritonal, the present standard explosive filler in general purpose bombs, is an 80/20 ratio, by weight, of TNT and aluminum powder. The blast effect is greater than TNT, and its sensitivity is of the same order of magnitude as TNT.

HBX. The newest explosive being con-

sidered for use in bombs is HBX, a mixture of RDX, TNT, aluminum powder, and desensitizer. Like Tritonal, its use will be in general purpose bombs.

Components of a Complete Round

A "complete round" is the term used to indicate a bomb with all its components as it is suspended from the rack or shackle of the aircraft ready for flight. Some of the major components of bombs are:

Bomb Body. The bomb body is the container that holds the filler. This filler may be either an explosive, incendiary, chemical, or napalm mixture.

Fin Assembly. The fin assembly is the flight stabilizer of the bomb and usually is made of sheet metal.

Fuzes. Fuzes are the means for bomb detonation. They contain sensitive explosives and should be handled accordingly.

Arming Wire Assembly. This item consists of either a single or double wire attached to a swivel loop, and is used to keep the fuzes safe prior to release of the bomb from the aircraft. Arming wires together with Fahnestock clips usually are shipped in a separate container.

Suspension Lugs. Suspension lugs may be either welded to, bolted on, or screwed into the bomb body. Lugs for double-hook racks are either 14 or 30 inches apart, depending upon the size of the bomb. On bombs currently in use, a lug for single-hook suspension is located on the side of the bomb body opposite the double lugs. In the new series of Air Force bombs and low-drag series Navy bombs, it is located midway between the double lugs.

Hoisting Lugs. These lugs are either welded to or screwed into the bomb body. The hoisting lug usually is located between the double suspension lugs.

Classification of Bombs

Bombs described in this publication are classified according to use as follows:

- Armor-piercing (AP)
- Semi-armor-piercing (SAP)
- General Purpose (GP)
- Low-drag General Purpose (Low-drag GP)
- Fragmentation (Frag)

- Fragmentation Clusters
- Light-case Demolition (Dem)
- Aircraft Depth (AD)
- Practice (P)
- Miniature Practice (MP)
- Fire

Armor-piercing Bombs. Armor-piercing bombs have a heavy case and a thick nose. Approximately 13 percent of the bomb's weight consists of explosive. This type of bomb is used against heavy armor and reinforced concrete. To be most effective, an armor-piercing bomb should score a direct hit on its target, because it has less explosive and therefore less blast effect than other bomb types. These bombs contain a delay-action tail fuze only to permit penetration of the target before the bomb explodes.

Semi-armor-piercing Bombs. These bombs have a medium heavy case and normally are tail-fuzed; however, the solid-metal nose plug can be replaced with a nose fuze, when it is tactically necessary. Thirty percent of the complete weight of the bomb is explosive. Semi-armor-piercing bombs sometimes are used as substitutes for general purpose bombs.

General Purpose Bombs. These bombs are used in the majority of bombing operations. The case is relatively light, and approximately 50 percent of the complete weight of the bomb is explosive. General purpose bombs may use both nose and tail fuzes.

A conical fin may be used instead of the box-type fin with the AN series GP bombs. The conical fin improves the aerodynamic characteristics of the bomb.

Fragmentation Bombs. The bodies of fragmentation bombs, with the exception of Fragmentation Bomb M83, usually consist of a thin steel tube with square wire spirally wound on the outside. The wire provides the principal source of fragments when the bomb is detonated. The explosive filler is about 14 percent of the total weight of the bomb. Fragmentation bombs are used against personnel and light materiel. These bombs have provisions for either a nose or tail fuze. Some of the smaller bombs have provisions for only a nose fuze. Also, the lock-ring thread often is used for the attachment of a parachute unit.

Light-case Demolition Bombs. These bombs are designed to carry maximum explosive charges. The percentage of explosive is 70 percent or more of the total bomb weight. These bombs should not be used where penetration is required. Demolition bombs are best used where blast will provide maximum damage. To ensure functioning upon impact, both a nose and a tail fuze are used.

Aircraft Depth Bombs. The aircraft depth bomb is used primarily against underwater targets. It has a secondary use as a demolition bomb. Because of its light case, approximately 70 percent of its complete weight is explosive. A flat nose prevents ricochet when dropped into the water. The depth bomb is fuzed with a hydrostatic tail fuze which functions at a predetermined depth rather than on impact. A nose fuze may be substituted for the hydrostatic tail fuze when used as a demolition bomb.

Practice and Miniature Practice Bombs. This type of bomb is used for target practice. There is a wide range of types and weights in order to simulate all types of service bombs. Some practice bombs have a fuze and a spotting charge; others are completely inert. Practice bombs generally are loaded with sand or water; some are fabricated to a desired weight.

Fire Bombs. A fire bomb is a thin-skinned

container of gasoline gel designed for use against dug-in troops, supply installations, wooden structures, and land convoys.

Fire bombs rupture upon impact or airburst to spread burning gasoline gel upon surrounding objects. One or more igniters or fuzes are used to ignite the gasoline mixture, upon impact. Chief use of the fire bomb is in low-level attack. On a high-level attack, a fire bomb will dig a crater and trap a large portion of the burning gel. This cratering effect can be reduced, in high-level attack, by fuzing the bomb to rupture prior to impact.

Markings

Bomb and bomb components are identified completely by standard nomenclature and ammunition lot numbers that are stamped on all packings and on the item itself.

Color Coding

Bombs are painted in various color schemes as a ready means of identification. Color bands, depending upon their color, size, and location, indicate the type of bomb and the type of explosive used. Identifying nomenclature and its color provide further identification of the bomb. Color coding is indicated in the following tabulation.

BOMB COLOR CODING

Type of Bomb	Explosive Filler	Color of Body	Color of Bands	Color of Markings
GP and Dem	TNT, Tritonal, Amatol.	Olive drab	Yellow	Black or yellow.
GP and Frag	Comp B	Olive drab	Yellow	Black.
Frag	TNT	Olive drab	Yellow ¹	Black or yellow.
AP, SAP, or AD.	Expl D Amatol	Olive drab	Yellow	Black.
Practice	Inert	Black ²	None	White.
Fire	Napalm	Olive drab	Purple	Black or yellow.

¹ Small fragmentation bombs (under 90 lbs) are painted on the nose and base in lieu of an actual color band.
² 4-lb Fragmentation Bombs M83 have a 1/2-inch yellow band around the bomb casing.

² Some practice bombs are unpainted.

Model Numbers

To distinguish between different designs of the same type, a model number is assigned when a design is adopted as a standard item.

Navy. Items of Navy design are designated by the word "Mark" or its abbreviation "Mk" followed by an arabic numeral. Modifications of the original design are indicated by the abbreviation "Mod" and an arabic numeral following the "Mod" designation. An original design item includes the term "Mod 0" to distinguish it from later modifications.

Army. On items of Army design, the model designation consists of the letter "M" followed by an arabic numeral. Modification of the original design is indicated by the letter "A" and an appropriate arabic numeral is added after the "A".

Army-Navy. Certain items have been standardized for use by both the Army and Navy. The model designation of such an item is prefixed by the letters "AN". When an AN item is de-standardized by either the Army or Navy, the AN is deleted from the model designation; however, to preclude loss of identity, the AN designation is shown parenthetically in standard nomenclature; for example, M120A1 (AN-M120A1). When an item is classified as AN standard, the previous model is shown parenthetically; for example, AN-M146 (M146).

Safety Precautions

Most bombs and their components are shipped separately and are assembled in the field to form a complete round. Preparing bombs for flight requires extreme care, because a mis-step may prove fatal. This is especially true of bombs installed with fuzes which incorporate an anti-withdrawal device. Any attempt to unscrew these fuzes will result in the functioning of the anti-withdrawal mechanism, and instantaneous detonation. Be absolutely sure of your procedure; follow assembly instructions carefully.

Safety Precautions To Be Observed

1. Fuzes and bombs shall not be unpacked in advance of requirements. They shall be returned to their original packings, if not used.
2. Fuzes shall not be assembled to bombs in anticipation of future needs.

3. Any accidentally armed fuze, either fully or partially armed, must not be handled except by authorized personnel.

4. Guard fuzes against dropping or bumping at all times, to prevent detonation.

5. Protect long-delay tail fuzes from excessive heat, shock, or damage.

6. Examine indicator vials of long-delay fuzes when fuze packing is opened, to determine if a leak has developed. If all fuzes in the box are not used, the vials shall be left in the box with the remaining fuzes and inspected again when the box is reopened.

7. Screw fuzes into bombs **HANDTIGHT ONLY**. Never use a tool, unless authorized. Tools may distort fuzes, causing premature detonation.

8. Use only a "screwing-in" motion when installing long-delay tail fuzes.

9. Do not remove warning tags when fuzes are installed in bombs.

10. Never remove safety cotter pins or car seals from fuzes prematurely.

11. Handle and install arming vanes of fuzes with care to prevent distortion of blades and the malfunction of both fuze and bomb.

12. Never defuze a bomb equipped with an anti-withdrawal device; it is certain to detonate. Dispose of fuzed bomb in accordance with NAVORD Instruction 8150.1.

13. Replace all safety pins when defuzing a bomb.

WARNING

Fuzes equipped with anti-withdrawal devices must not be removed from bombs.

14. Never allow primer detonators to drop or strike an object; they are extremely sensitive and rough handling may explode them.

15. Do not use a fin assembly if it cannot be secured to the bomb properly. If the fin assembly is loose and turns on the bomb, it will pull the arming wire from the tail fuze, and the fuze may arm before the bomb is dropped.

16. Do not use a defective arming wire: one with kinks, twists, or burrs.

Section 1.2—Fuzes

A bomb fuze is a device used to cause the bomb to explode at the time and under the circumstances desired. This is accomplished by the use of sensitive explosive elements and the required mechanical or electrical action. The most important considerations that fuzes provide are control of detonation and safety in releasing of bombs.

To achieve different types of control for varied types and sizes of bombs, many varieties of fuzes are required. These different varieties of fuzes are installed in different locations in the bombs.

Normally, fuzes are in a "SAFE" or "UN-ARMED" condition, figure 1.2, to make sure that they do not detonate prematurely. In the "UNARMED" condition, fuzes cannot cause the bomb to explode. A fuze is ready to detonate the bomb when all parts are in

or can move into alignment, so that the fuze may operate. This is known as the "ARMED" condition. This usually is accomplished by either the ejection of an arming pin, the rotation of an arming vane, or both.

Classification of Fuzes

For control of detonation, there are five types of fuzes:

IMPACT FUZES function upon impact, either instantaneously or with a short time-delay after impact.

TIME FUZES will not detonate until a predetermined time has elapsed after release.

HYDROSTATIC FUZES are operated by water pressure, functioning at a predetermined depth.

ANTI-DISTURBANCE FUZES will function if they are disturbed in any manner after impact.

PROXIMITY (VT) FUZES are essentially

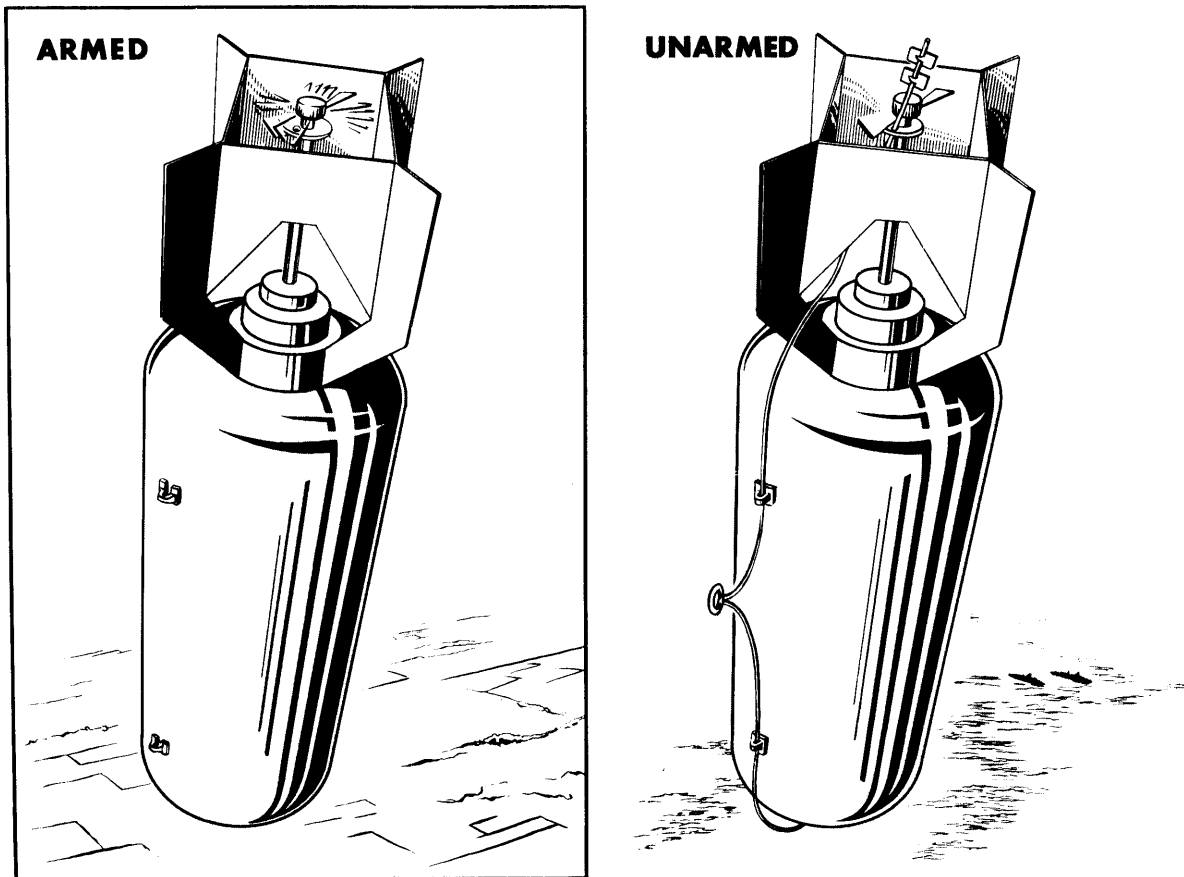

Figure 1.2—Bombs Released "ARMED" and "UNARMED".

radio transmitting and receiving units. In free flight, they are detonated by the reflection of their transmitted radio signals.

Installation

Fuzes must suit the function or purpose of the bomb in which they are to be installed. They are designed for installation in the nose, in the tail, or on the side of a bomb.

Fuzes usually fit the small-size bombs of a series, without any additional auxiliary parts. As the bombs increase in size, standardized fuze seat liners and adapter-boosters are needed. These compensate for the increased diameter and depth of the fuze well. Nose and tail fuze seats are machined in the bomb casing. Their dimensions (thread size and depth of seat) are standardized for maximum flexibility of use.

Components that make fuzing possible in the larger bombs are:

The FUZE SEAT LINER is a metal cup, assembled inside the nose of the bomb to keep

the cavity clear for installing the fuze. Tail adapter-boosters are usually the fuze seat liners for tail fuzing.

The AUXILIARY BOOSTER consists of a column of tetryl pellets or other sensitive explosive in a suitable container. Its function is to relay and amplify the detonation wave from the booster to ensure proper detonation of the main charge.

The ADAPTER-BOOSTER is a bushing threaded on both the inside and outside and is used for the assembly of fuzes to larger bomb bodies. It includes an explosive booster charge.

Installation of the proper fuze in a bomb is essential in order to locate the arming vanes in the airstream. Usually, the same family group of nose and tail fuzes are used throughout a series of bombs. Location of the vanes in the airstream is controlled by the fuze arming stem tube. The overall length in a family group of fuzes (Example: AN-M100A2, AN-M101A2, and AN-M102A2) increases in the order given. Thus, it is possible to have identical fuze action in various sizes of bombs.

Section 1.3—Arming Wires

The arming wire is a very important component of a fuzeed bomb. It is the means of starting the explosive train that detonates the bomb. It also is used to lock the fuze arming mechanism in the unarmed position. When a bomb is released from the rack, the wire is pulled from the fuze head, allowing the fuze vanes to rotate. This allows the fuze to arm.

If a bomb is to be dropped from an aircraft "SAFE", the arming wire is released with the bomb, thus preventing the fuze vanes from rotating.

The wires usually consist of either one or two strands attached to a swivel loop. Safety Fahnestock clips are attached to the ends of the wires after installation of fuzes in the bomb. This prevents accidental withdrawal of the arming wires, with consequent premature arming of the fuzes, while the aircraft is in flight.

The standard arming wire assemblies, figure 1.3, will fit any bomb up to and including 2000 pounds. For larger bombs, an extension cable is supplied. After the bomb is installed on the shackle, excessive wire is cut to approximately 2½ inches beyond the fuze. For proper release, wire should be free from twists, kinks, and burrs. The use of arming wire brackets is

required on fuzes used with armor-piercing and depth bombs. Brackets are furnished with armor-piercing bomb fin assemblies. They should be separately requested for use with depth bombs. A metal tubular protector is supplied for use with the arming wire bracket to prevent chafing of the arming wire by vibration of the fuze vane.

Arming wires are packed in metal containers or spiral-wound fiber containers containing 50 or 100 assemblies and overpacked in a wooden box. Safety Fahnestock clips generally are packed with the wires.

Fragmentation bomb clusters are an exception. Each cluster is supplied with its own arming wire assembly.

The most commonly used arming wire assemblies, figure 1.3, are:

- Mk 1
- Mk 1, Extension
- Mk 2
- Mk 3
- AN-M1A2
- AN-M6A2
- AN-M7A1
- AN-M8A1
- M13
- M16

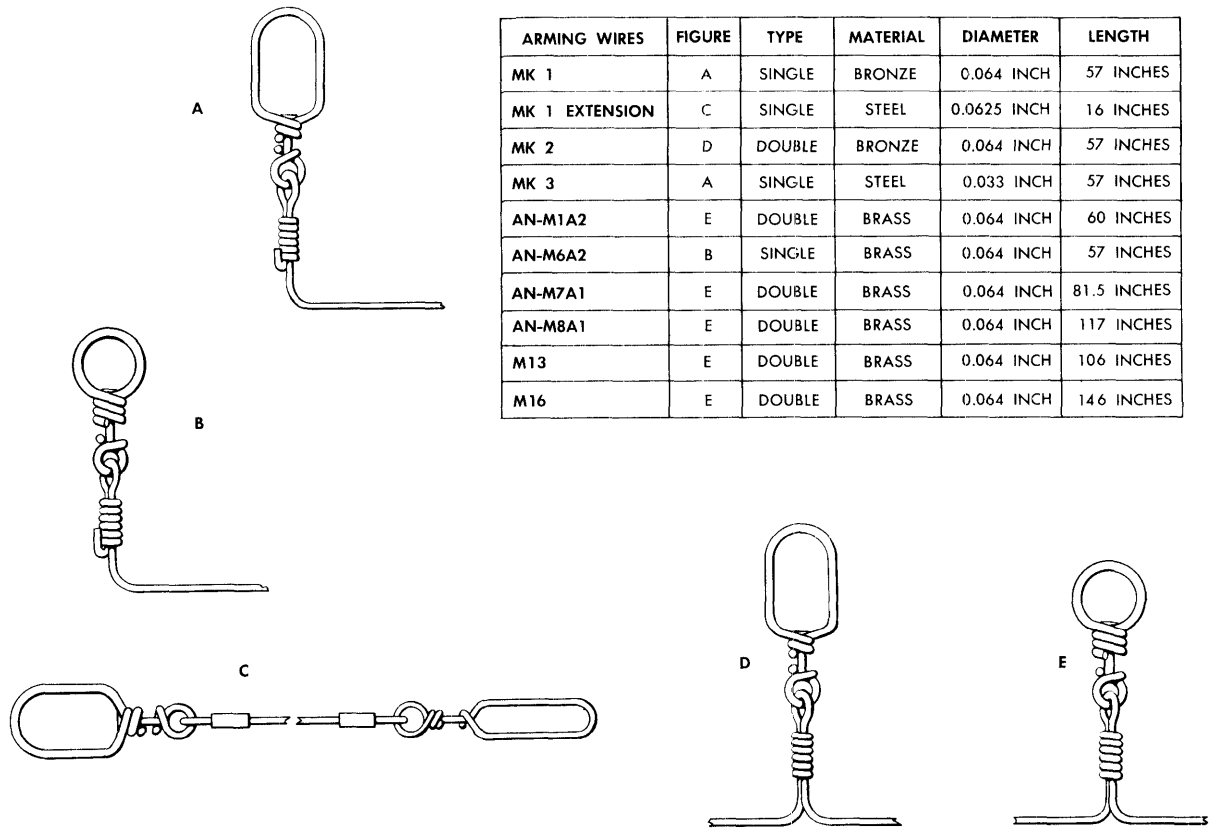

Figure 1.3—Arming Wires.

Section 1.4—Packing

Generally, bombs are separated into basic components or assemblies for shipping and stowing. The components are packed in a manner that facilitates handling, provides safety for personnel and maximum protection for components.

The bomb body, the fin assembly, and the fuzes are packed individually. Fuzes usually are packed in sealed containers. Refer to OP 988 (First Revision) for detailed instructions on packing of fuzes.

Arming wires, in rare cases, are packed as components of the bomb, but in general, they are packed in separate containers in lots of 50 or 100 assemblies, figure 1.6. Small bombs may be packed as units, less fuzes.

Packing depends upon the size, shape, and composition of the component. The following table describes the usual packing for the various types of bombs.

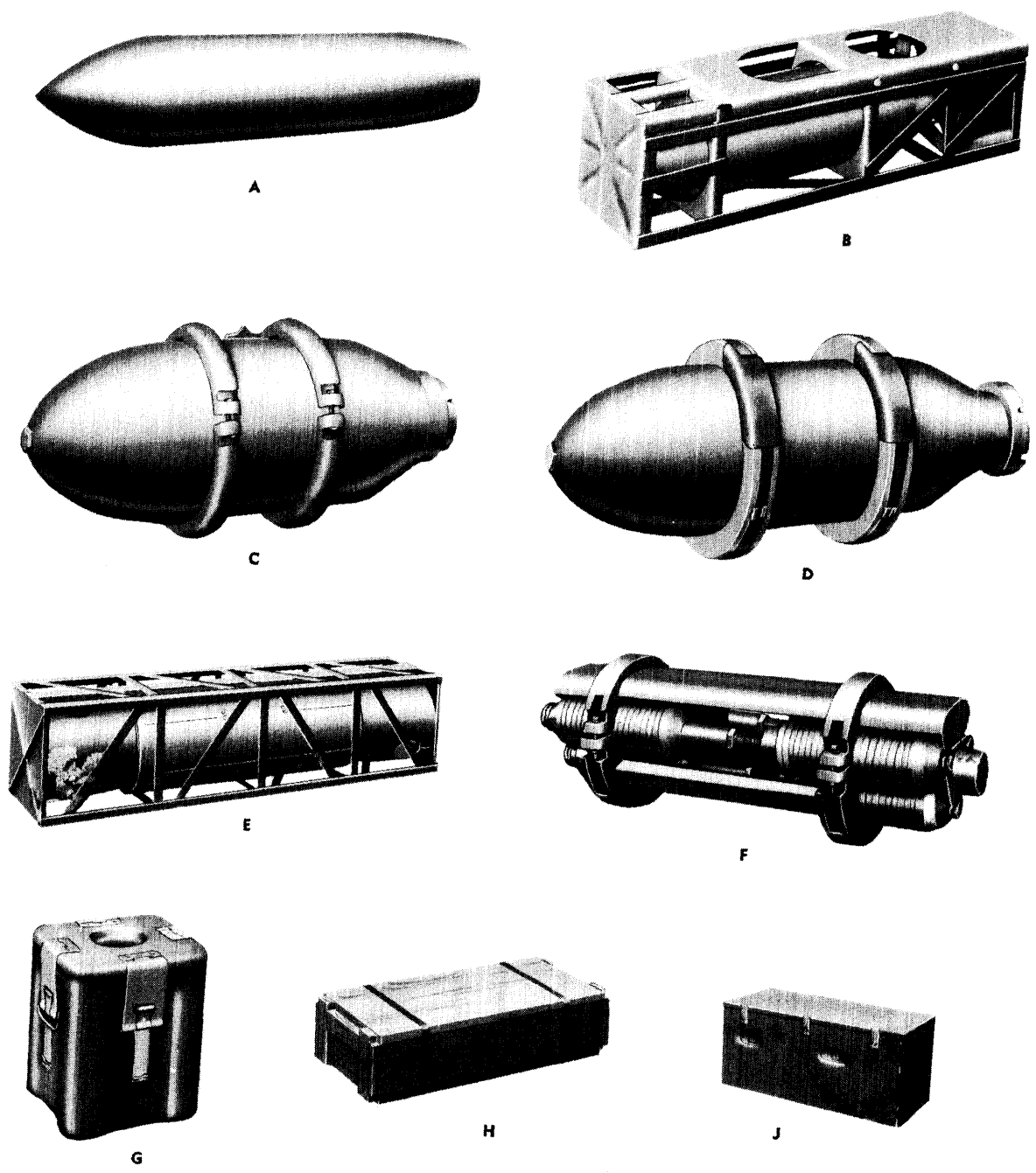

Figure 1.4—Packing of Bombs.

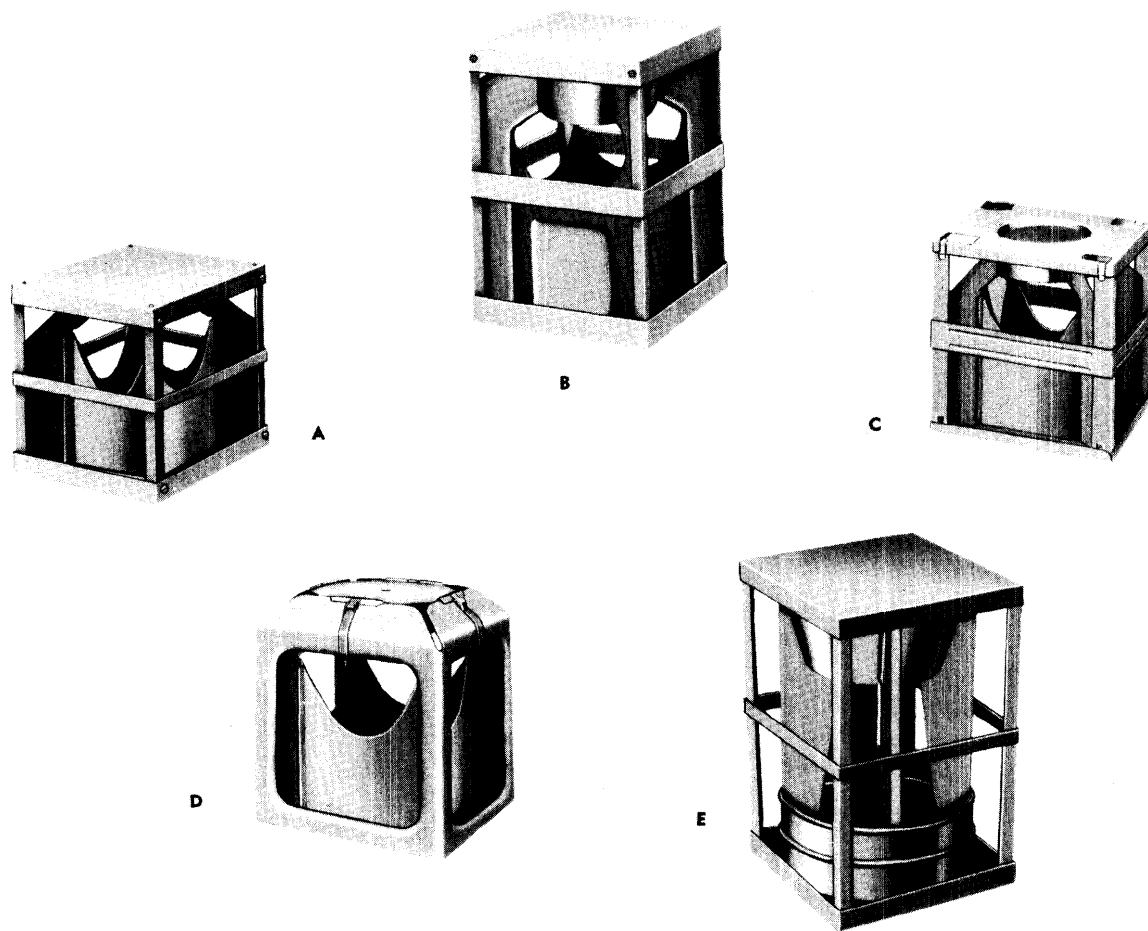

Figure 1.5—Packing of Fins.

CONFIDENTIAL

INTRODUCTION

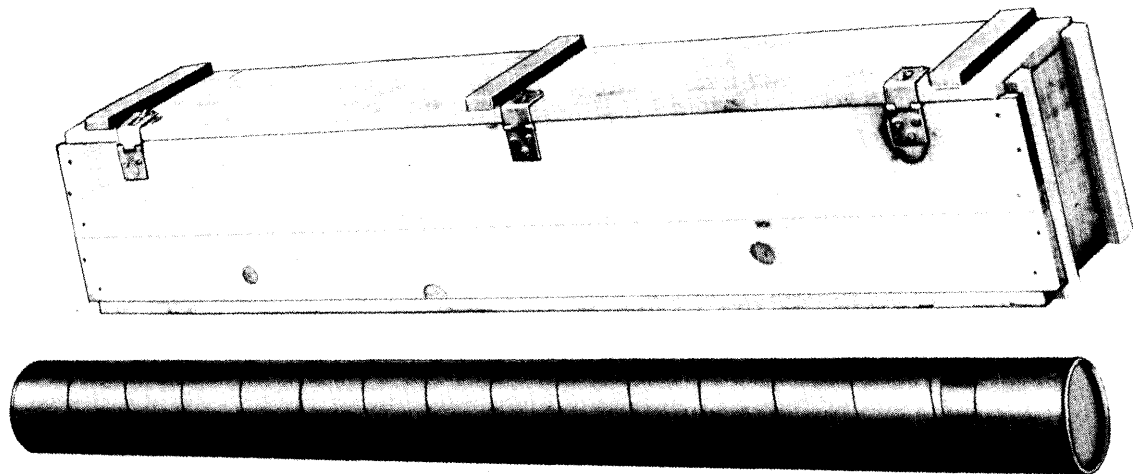

Figure 1.6—Packing of Arming Wires.

CONFIDENTIAL

PACKING

Bomb Type	Bomb Body	Figure Reference	Fin Assembly	Figure Reference	Assembled Bombs	Figure Reference
Armor - piercing Bombs (AP).	No protection; fuze cavities plugged.	Fig. 1.4 Sketch A.	Metal containers with lugs, arming wires, and mounting screws.	Fig. 1.5 Sketch B.		
Semi - armor - piercing Bombs (SAP).	Metal shipping rings; fuze cavities plugged.	Fig. 1.4 Sketch C.	Metal containers	Fig. 1.5 Sketch C.		
General Purpose Bombs (GP).	Metal or composition shipping rings; fuze cavities plugged.	Fig. 1.4 Sketches C and D.	Metal containers	Fig. 1.5 Sketch A.	100-lb GP Bomb shipped as a unit in metal container.	Fig. 1.4 Sketch B.
Fragmentation Bombs (Frag).	Metal shipping rings; fuze cavities plugged.	Fig. 1.4 Sketch C.	Metal containers	Fig. 1.5 Sketch D.	In clusters of or wafers (Refer to Frag Clusters).	Fig. 1.4 Sketch F.
Fragmentation Bomb Clusters.					Shipping Bands	Fig. 1.4 Sketch F.
Aircraft Depth Bombs (AD).	Metal containers	Fig. 1.4 Sketch J.	Metal containers	Fig. 1.5 Sketch E.		
Miniature Practice Bombs (MP).					Metal or wood containers.	Fig. 1.4 Sketches G and H.
Practice Bombs	Fiberboard, wood, or no containers.		Metal containers	Fig. 1.5 Sketch C.	Metal or wood containers.	Fig. 1.4 Sketch H.
Fire Bombs	Metal containers	Fig. 1.4 Sketch E.	Metal containers	Fig. 1.4 Sketch E.		

CONFIDENTIAL

OP 1280 (First Revision)

CONFIDENTIAL

CONFIDENTIAL

Chapter 2

ARMOR-PIERCING BOMBS

Section 2.1—General

Section 2.2—1000-lb AP Bomb AN-Mk 33 and Mods

Section 2.3—1600-lb AP Bomb AN-Mk 1 and Mods

CONFIDENTIAL

17-18

Chapter 2

ARMOR-PIERCING BOMBS

Section 2.1—General

Description

Armor-piercing bombs have extremely heavy cases. The weight of an AP bomb is concentrated in its solid metal nose. The cavity of these bombs usually tapers toward the nose and aft sections; thus, providing the wall thickness required to withstand impacts on hard targets. A box-type fin fits onto the conical aft section of the bomb body and is secured in place by a fin locknut.

Armor-piercing bombs use a delay-action tail fuze. This results in deeper penetration of the target before initiation of its bursting charge of explosive D. One auxiliary booster is used. The auxiliary booster is furnished in place in the bomb fuze cavity.

Two suspension lugs and one hoisting lug are secured to the bomb body with cap screws. All three lugs are located on the same side of the bomb.

Approximately 13 percent of the released weight of the armor-piercing bombs is high-explosive filler.

Usage

Because of its physical characteristics and functions, the AP bomb is used for piercing heavily armored targets, reinforced concrete or heavy steel construction. Because of the limited explosive content, direct hits are essential. A high-impact velocity is required for deep penetration of the target. This velocity is gained by releasing the bombs at high altitudes.

Armor-piercing Bombs (Figure 2.1)

- 1000-lb AP Bomb AN-Mk 33 and Mods
- 1600-lb AP Bomb AN-Mk 1 and Mods

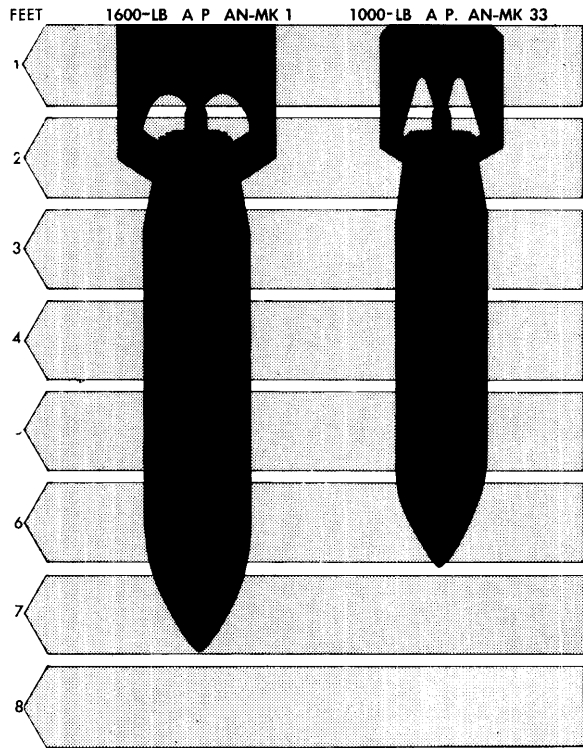

Figure 2.1—Armor-piercing Bombs, Comparative Size.

Fuzes Compatible with AP Bombs

Tail Impact Fuze AN-Mk 228 is the only fuze used in armor-piercing bombs. It is a short-delay fuze that ensures penetration of the target before detonation. An arming vane bracket is used with the installation of Tail Impact Fuze AN-Mk 228.

Markings

Yellow bands of various widths and locations categorize the AP bomb as to its filling and classification. The color scheme consists of a

three-inch band on the tail end, a one-inch band on the nose, and a broken ¼-inch band at the center of gravity. This latter band may be omitted from some bombs.

An olive-drab painted body affords protection from rust and prevents easy detection of stock piles from the air.

Bomb components are identified completely by standard nomenclature and ammunition lot number stenciled on all packings and, if size permits, on each item.

On the conical aft portion of the body in ¼-inch letters, and on the mid-section of the bomb in ½-inch letters, the following information is stamped:

- Bomb type
- Bomb case number
- Manufacturer's name
- Contract number
- Lot number
- Inspector
- Serial number
- Weight of body in pounds
- Drawing number

Suspension

Armor-piercing bombs are issued with suspension lugs, hoisting lugs, and cap screws for securing the lugs to the bomb body. The lugs are not attached to the bomb body but are packed in the tail crate.

The bomb bodies are drilled and tapped at the points required for the attachment of suspension and hoisting lugs. The proper fittings are selected for the type of suspension or hoisting desired. The shipping screws plugging the tapped holes are removed, and the fittings are attached with cap screws.

Safety Precautions

Most bombs and their components are shipped separately and are assembled in the field to form a complete round. Preparing bombs for flight requires extreme care, because a mis-step may prove fatal. Nothing should be taken for granted; every step must be checked and double-checked.

Safety Precautions To Be Observed

1. Fuzes and bombs shall not be unpacked in advance of requirements; they shall be returned to their original packings, if not used.
2. Any accidentally armed fuzes, either fully or partially armed, must never be handled except by authorized personnel. The fuzes if installed may detonate the bomb.
3. Guard fuzes against dropping or bumping at all times, to prevent accidental detonation.
4. Never remove safety cotter pins or car seals from fuzes prematurely.
5. Screw the fuze into bomb **HANDTIGHT ONLY**. A suitable spanner wrench may be used for this operation, if required.
6. All safety cotter pins must be replaced when defuzing a bomb.
7. Handle and install arming vanes of fuzes with care to prevent distortion of blades and the resultant malfunction of both fuze and bomb.
8. Do not use a fin assembly if it cannot be secured to the bomb properly. If the fin assembly is loose and turns on the bomb, it will pull the arming wire from the tail fuze, causing the fuze to arm before the bomb is dropped.
9. Never use a defective arming wire: that is, one with kinks, twists, or burrs.

Section 2.2—1000-lb AP Bomb AN-Mk 33 and Mods

Description

The 1000-lb AP Bomb AN-Mk 33 is a thick metal-cased bomb with a solid, pointed nose. The bomb is equipped with a box-type fin assembly, figure 2.2.

The only fuze authorized for use with Bomb AN-Mk 33 is Tail Impact Fuze AN-Mk 228. The bursting charge is explosive D. Approximately 13 percent of the complete released weight of the bomb is explosive charge.

Suspension lugs are screwed to the bomb body 14 inches apart. A hoisting lug is screwed to the body between the two suspension lugs at the center of gravity. Yellow bands of varying widths are painted on the nose and aft portion of the bomb case. The protective paint coating of olive drab identifies the high-explosive filler. Standard nomenclature is stenciled in black on the nose, mid-section, and conical aft portion of the casing.

Differences Between Mods

There are no physical differences between Mods 1, 2, and 3. The Mod number is used only to identify the manufacturer.

Physical Characteristics

- Weight of assembled fuzed bomb:
 - Loaded with explosive D. 1008 lbs
- Weight of explosive:
 - Explosive D. 140 lbs
- Weight of fin:
 - Fin Assembly (Dwg 328811) 21.5 lbs
- Dimensions:
 - Length or height of complete bomb 73.0 inches
 - Length of bomb body 58.0 inches
 - Diameter 12.0 inches
 - Fin span 16.0 inches
 - Fin length 17.0 inches
- Suspension:
 - Two suspension lugs 14 inches c to c
 - Hoisting lug (single) Center of gravity

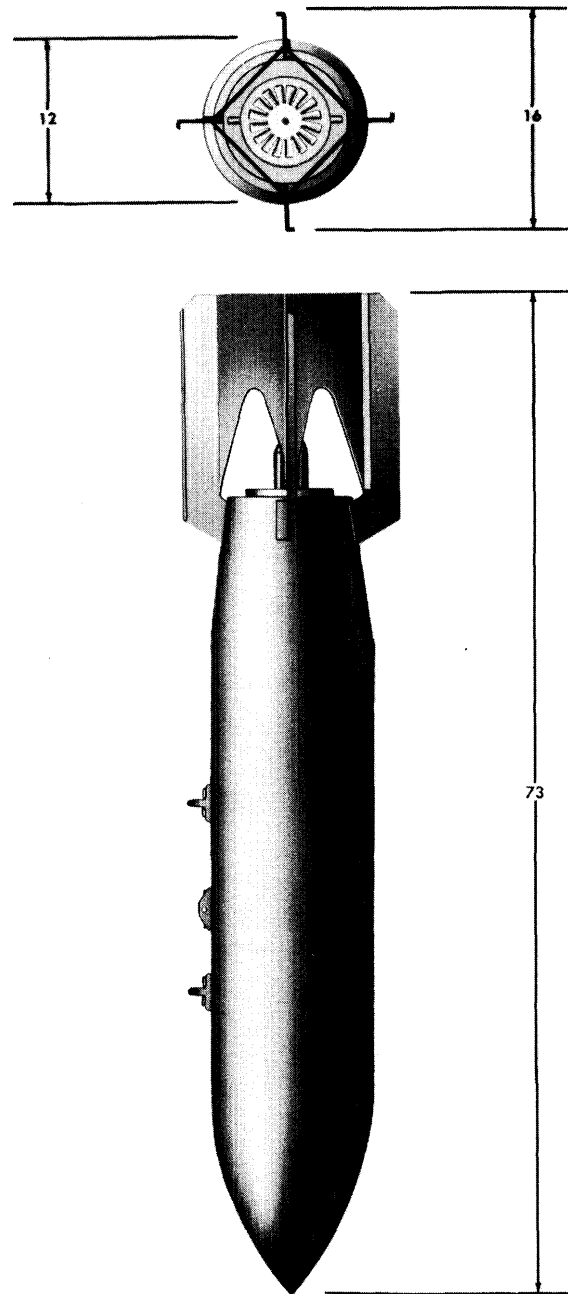

Figure 2.2—1000-lb AP Bomb AN-Mk 33.

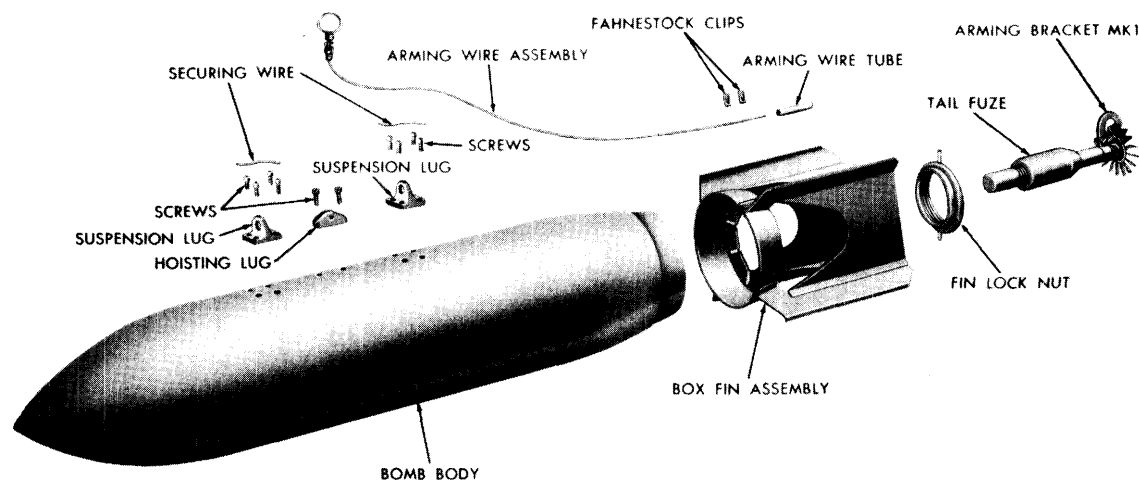

Figure 2.3—1000-lb AP Bomb AN-Mk 33, Exploded View.

Components of a Complete Round (Figures 2.3, and 2.4)

Bomb body assembly (including):

- Bomb body
- Shipping plugs
- Fin locknut

Auxiliary Booster Mk 1 Mod 0

Fin Assembly (Dwg 328811)

Suspension lugs with slotted cap screws

Hoisting lug with slotted cap screws

Tail fuze:

AN-Mk 228

Arming Wire Assembly Mk 1 or AN-M6A2

Arming Bracket Mk 1 Mod 0

Fahnestock clips

Assembly

CAUTION: Fuzes and bombs shall not be unpacked in advance of requirements and shall be returned to their original packings, if not used.

1. Remove shipping plugs from the holes that are used for securing suspension lugs or hoisting lug. Clean the holes.
2. Remove the fin assembly and attachments from their shipping crate.

CAUTION: Use only fin assemblies that are in good condition. Reject fin assemblies which are rusted, dented, bent, or have loose fins.

3. Remove required fuze and arming wire from their packings and inspect; particularly be sure the fuze is unarmed by observing through inspection window in the fuze.

CAUTION: Only safe and serviceable fuzes shall be used in the assembly of the complete round. When opening the packing boxes, if any of the hermetically sealed containers are damaged or have broken seals, the fuzes within such containers shall be considered unserviceable. This does not apply to those fuzes repacked in the field and resealed with adhesive tape for temporary protection. These fuzes should be examined carefully for serviceability. All fuzes should have their safety devices (cotter, shear, and arming pins) in place. If any safety device is missing, handle the fuze with extreme care; return the fuze to its container, and mark the container for disposal by authorized personnel.

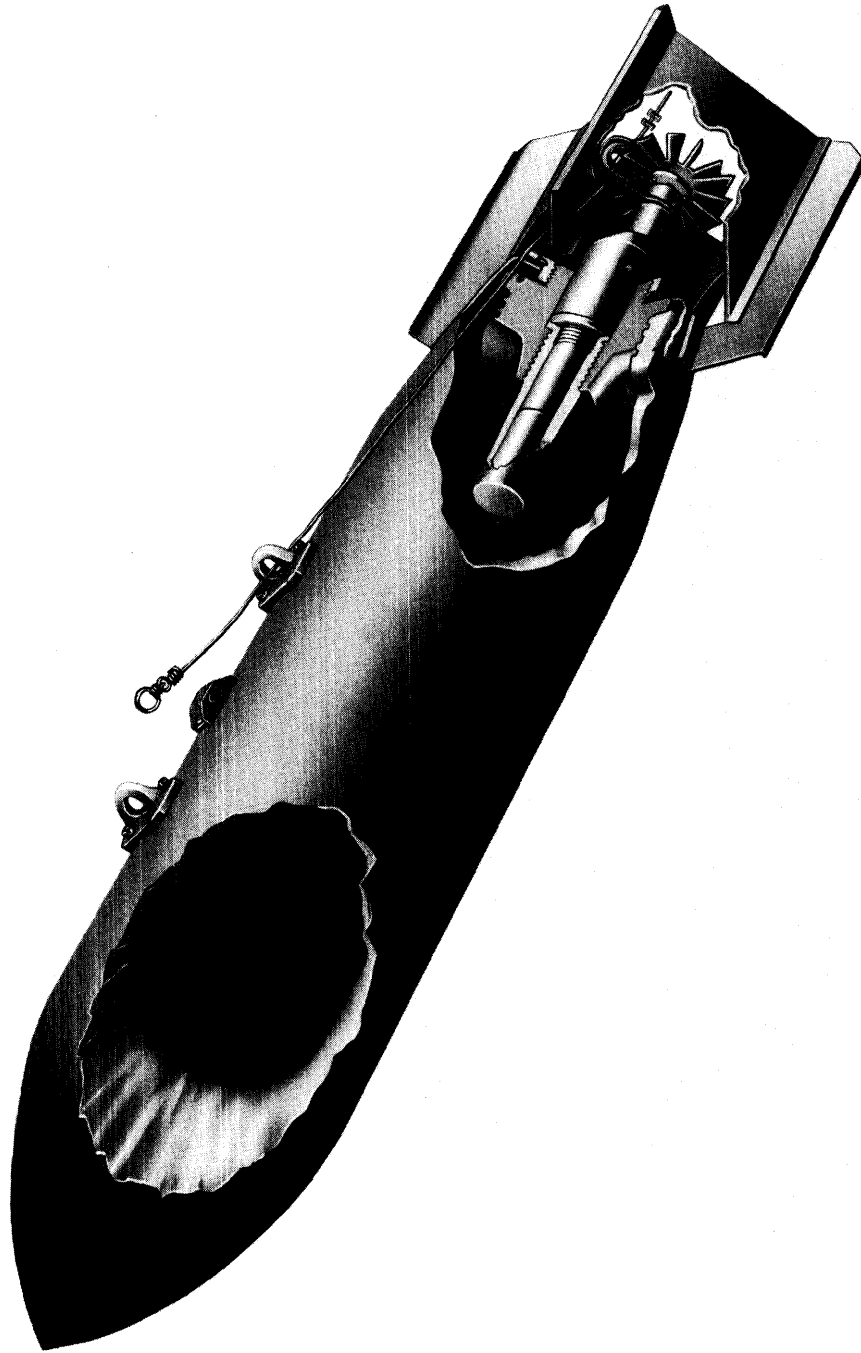

Figure 2.4—1000-lb AP Bomb AN-Mk 33, Cutaway View.

4. Attach suspension fittings. Tighten securely. Screws holding suspension lugs should be safety-wired in pairs.

CAUTION: Inspect suspension and hoisting lugs for damage or defects before securing them to bomb body. Replace if necessary.

5. Remove shipping plug from fuze cavity of bomb. Be sure the auxiliary booster is in place and that the tail fuze seat is clean.

6. Back off setscrew and unscrew fin locknut. Locate fin vanes in a position that will clear aircraft structure and ground, when installed on aircraft. Replace fin locknut and tighten. Hold a wooden drift against the pins of the locknut. Tap drift lightly. Tighten setscrews on locknut.

CAUTION: Do not use a fin assembly if it cannot be secured to the bomb properly. If fin assembly is loose and turns on the bomb, it will pull the arming wire from the tail fuze, and the fuze may arm before the bomb is dropped.

7. Tail Impact Fuze AN-Mk 228 is used with the 1000-lb AP Bomb AN-Mk 33.

8. For detailed information on fuzing and defuzing, refer to OP 988 (First Revision).

CAUTION: Never use an arming wire that is twisted, kinked, or burred. These conditions are caused by mishandling. Burrs may result when the arming wire is cut to its required length or they may occur at any other time. To remedy this condition, file or recut the arming wire.

Section 2.3—1600-lb AP Bomb AN-Mk 1 and Mods

Description

The 1600-lb AP Bomb AN-Mk 1, figure 2.5, is a thick metal-cased bomb with a solid, pointed nose. The thick metal case is designed to penetrate the heaviest horizontal armor of combat ships. The bomb is equipped with a box-type fin assembly.

The only fuze authorized for use with Bomb AN-Mk 1 is Tail Impact Fuze AN-Mk 228. The bursting charge is explosive D. Approximately 13 percent of the weight of the complete round is explosive filler.

Suspension lugs are screwed to the bomb body. Four sets of mounting holes in the bomb body are used to mount the suspension lugs, with either 14 or 30 inches between centers. A hoisting lug is screwed to the body between the suspension lugs at the center of gravity.

The bomb is painted olive drab. A one-inch yellow band encircles the nose end of the bomb, and a 5.75-inch band encircles the conical aft portion of the bomb. A 1/4-inch broken yellow band may be found at the center of gravity; however this is no longer required. Identifying nomenclature is stenciled in black on the bomb casing.

Differences Between Mods

The difference between AN-Mk 1 Mod 1, AN-Mk 1 Mod 2, and AN-Mk 1 Mod 3 is in the manufacturer only; the complete rounds contain the same components and are the same in all physical aspects.

Physical Characteristics

- Weight of assembled fuze
bomb:
- Loaded with explosive D 1590 lbs
- Weight of explosive:
- Explosive D..... 209 lbs
- Weight of fin:
- Fin Assembly (Dwg 28.50 lbs
294201)
- Dimensions:
- Length or height of 83.5 inches
complete bomb
- Length of bomb body 67.15 inches
- Diameter..... 14.0 inches

Dimensions—Continued

- Fin span..... 20.6 inches
- Fin length..... 21.1 inches

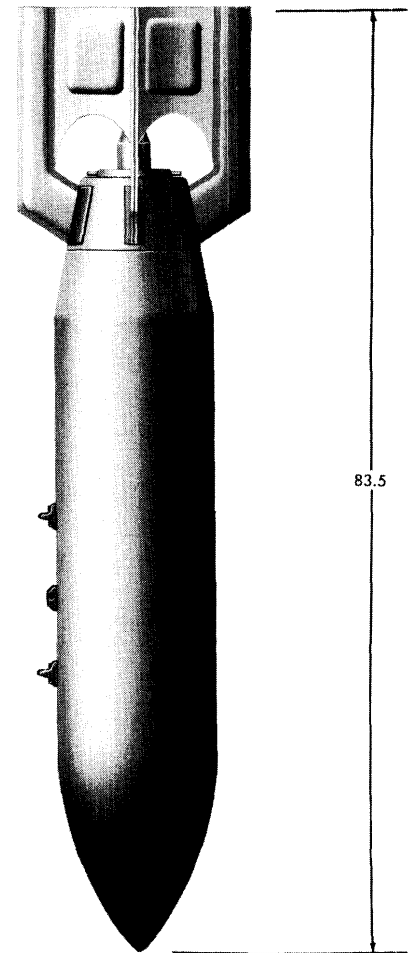
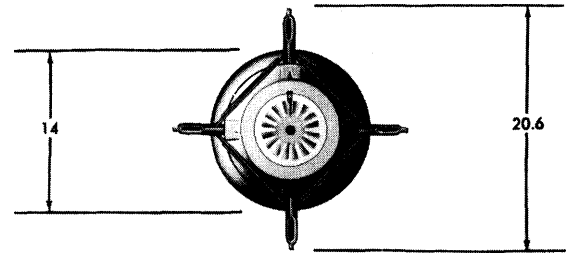

Figure 2.5—1600-lb AP Bomb AN-Mk 1.

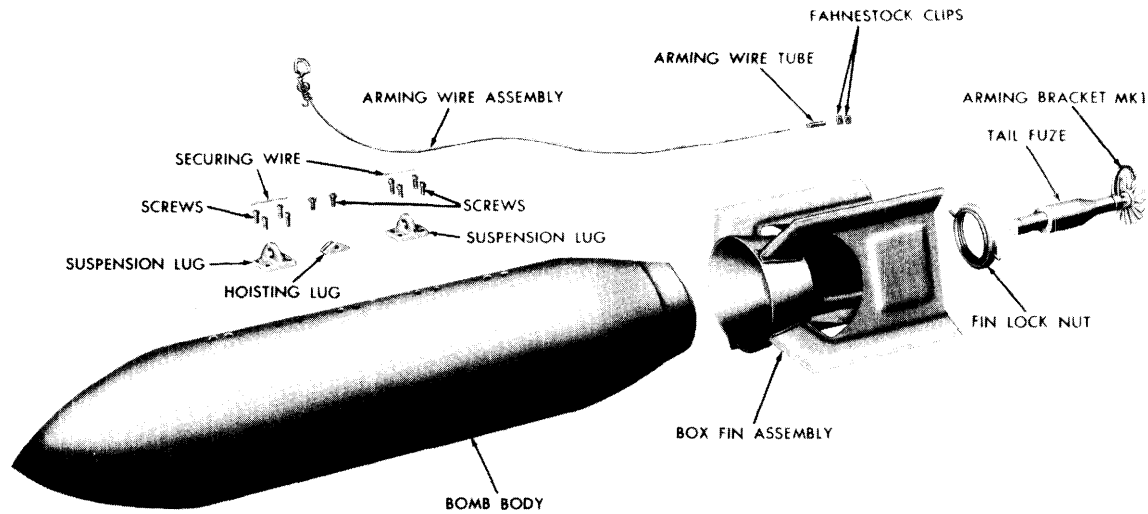

Figure 2.6—1600-lb AP Bomb AN-Mk 1, Exploded View.

Suspension

- Two suspension lugs----- 14 inches c to c
or
30 inches c to c
- Hoisting lug (single)----- Center of gravity

Components of a Complete Round (Figures 2.6 and 2.7)

- Bomb body assembly (including):
 - Bomb body
 - Shipping plugs
 - Fin locknut
- Auxiliary Booster Mk 1 Mod 0
- Fin Assembly (Dwg 294201)
- Suspension lugs with slotted cap screws
- Hoisting lug with slotted cap screws
- Tail fuze:
 - AN-Mk 228
- Arming Wire Assembly Mk 1 or AN-M6A2
- Arming Bracket Mk 1
- Fahnestock clips

Assembly

CAUTION: Fuzes and bombs shall not be unpacked in advance of requirements and shall be returned to their original packings, if not used.

1. Remove shipping plugs from the threaded holes in bomb body before attaching the suspen-

sion and hoisting lugs. Clean the threaded holes.

2. Remove fin assembly and attachments from their shipping crate.

CAUTION: Use only fin assemblies that are in good condition. Reject fin assemblies which are rusted, dented, bent, or have loose fins.

3. Remove required fuze and arming wire from their packings and inspect; particularly be sure the fuze is unarmed by observing through the inspection window in the fuze.

CAUTION: Only safe and serviceable fuzes shall be used in the assembly of the complete round. When opening packing boxes, if any of the hermetically sealed containers are damaged or have broken seals, the fuzes within such containers shall be considered un-serviceable. This does not apply to fuzes repacked in the field and resealed with adhesive tape for temporary protection. These fuzes should be examined carefully for serviceability. All fuzes should have their safety devices (cotter, shear, and arming pins) in place. If any safety device is missing, handle the fuze with extreme care. Return the fuze to its container, and mark the container for disposal by authorized personnel.

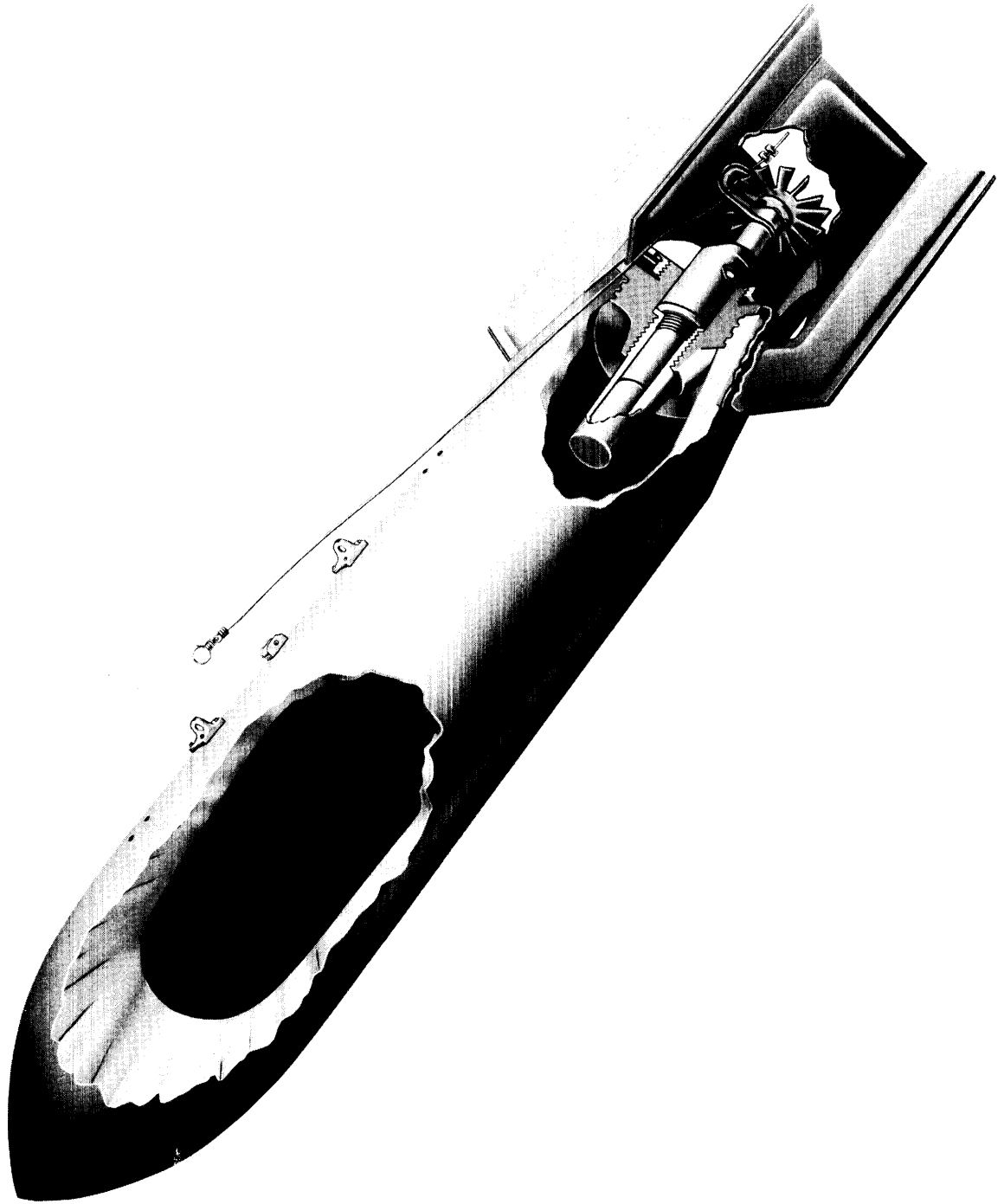

Figure 2.7—1600-lb AP Bomb AN-Mk 1, Cutaway View.

4. Attach fittings for suspension and hoisting, using slotted cap screws. Use a screwdriver, and tighten securely. Screws holding suspension lugs to bomb body should be safety-wired in pairs.

CAUTION: Inspect suspension and hoisting lugs for damage or defects before securing them to bomb body.

Replace if necessary.

5. Remove the fuze hole cover from the bomb, and clean threads if necessary. Be sure auxiliary booster is in place. Back off two setscrews holding tail locknut in place; remove locknut and fit tail to the body. Replace tail locknut and tighten by hand. Rotate vanes until their position clears airplane structure and ground,

when the bomb is installed. Tighten locknut securely. Hold a wooden drift against the pins of the locknut. Tap drift lightly. Tighten setscrews on locknut.

6. Tail Impact Fuze AN-Mk 228 is used with the 1600-lb AP Bomb AN-Mk 1.

7. For detailed information on fuzing and defuzing, refer to OP 988 (First Revision).

CAUTION: Never use an arming wire that is twisted, kinked, or burred. These conditions are caused by mishandling. Burrs may result when the arming wire is cut to its required length or they may occur at any other time. To remedy this condition, file or recut the arming wire.

Chapter 3

SEMI-ARMOR-PIERCING BOMBS

Section 3.1—General

Section 3.2—500-lb SAP Bombs AN-M58A2, AN-M58, and AN-M58A1

Section 3.3—1000-lb SAP Bombs AN-M59A1 and AN-M59

Section 3.4—2000-lb SAP Bombs M103

Chapter 3
SEMI-ARMOR-PIERCING BOMBS

Section 3.1—General

Description

Semi-armor-piercing bombs have bodies similar in contour to those of armor-piercing bombs. SAP bomb bodies are of thinner wall construction than those of the armor-piercing series. With but one exception (2000-lb M103) these bombs will accommodate both nose and tail fuzes. Most tactical uses do not require a nose fuze; in which case, the nose fuze seat cavity is fitted with a solid steel plug. The semi-armor-piercing series was developed to provide greater penetrative ability than that afforded by comparable weight general purpose bombs.

The bursting charge incorporated in semi-armor-piercing bombs is either Pieratol, TNT, or Amatol, and accounts for approximately 30 percent of the total bomb weight. The blast effect produced is considerably less than that of

general purpose bombs in the same weight class, but greater than that produced by corresponding weight armor-piercing bombs.

Usage

A case lighter than that of AP bombs, a higher-explosive content, and delay-action fuzing make the semi-armor-piercing bomb highly effective for horizontal, glide, and dive bombing operations. Armored ships, reinforced concrete construction, pill boxes, and bunkers are vulnerable targets for this type of bomb.

Semi-armor-piercing Bombs (Figure 3.1)

500-lb SAP Bombs AN-M58A2, AN-M58A1, and AN-M58

1000-lb SAP Bombs AN-M59A1 and AN-M59

2000-lb SAP Bomb M103

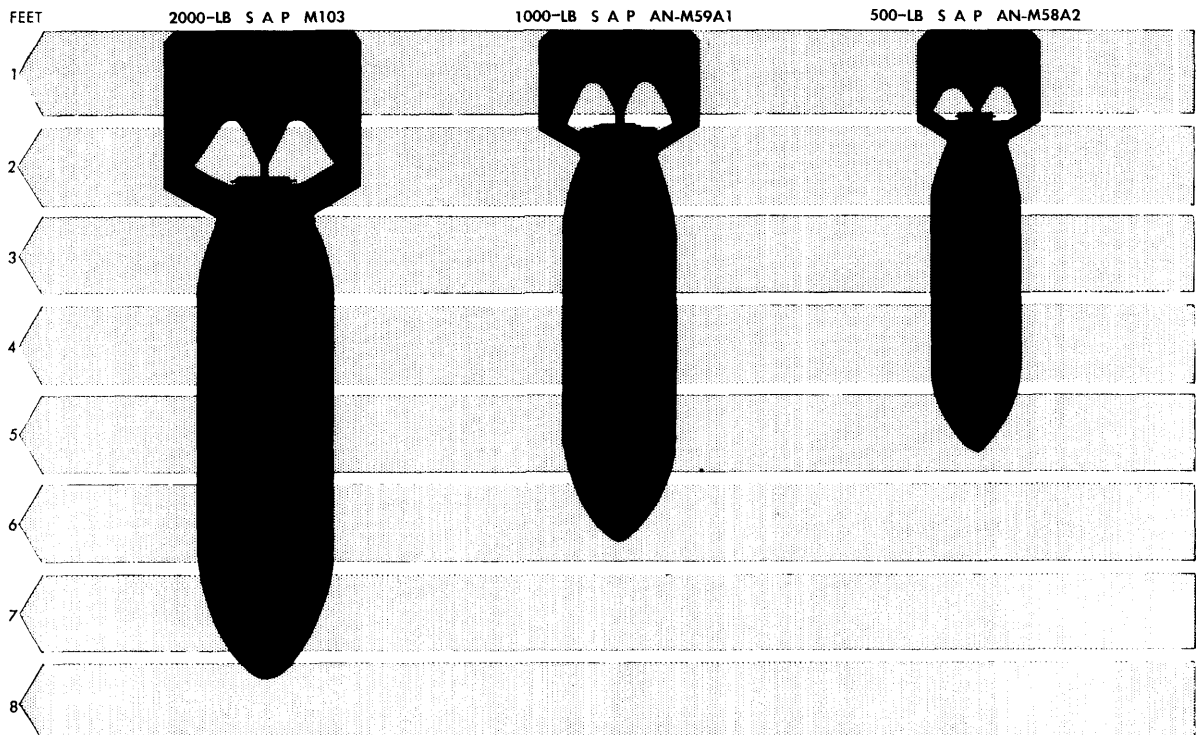

Figure 3.1—Semi-armor-piercing Bombs, Comparative Size.

Fuzes Compatible with SAP Bombs

Tail fuzes:

AN-M101A2
 AN-M102A2
 M115
 M116
 M117
 M123A1
 M124A1
 M125A1
 M132
 M133
 M134

Nose fuzes:

AN-M103A1
 AN-M139A1
 AN-M140A1

Markings

SAP bombs are identified by standard nomenclature which consists of name, type, weight, and model designation stenciled in black on the bomb body. The following information is stamped on the bomb.

Nose of bomb:

Type of bomb
 Weight of bomb
 Bomb case number

Conical aft portion of bomb:

Average gross weight (as shipped)
 Displacement (cubic feet)

Mid-section of bomb:

AIC symbol
 Explosive charge (Picratol, TNT, or AM 50/50)
 Lot number
 Explosive US bomb (indicates United States property)

Month and year of loading

WITH PAD (bomb contains wax pads in nose and tail)

Two 1-inch wide yellow bands circumscribe the bomb case, designating a high-explosive filler. One band is painted around the nose and the other encircles the tail end of the bomb.

A coat of olive-drab paint protects the bomb casing from rust and prevents easy detection of stock piles from the air.

Bomb components and packings are identified completely by standard nomenclature and ammunition lot number stenciled in black on all packings and on the item itself, if size permits.

Suspension

SAP bombs have single and double suspension lugs which are welded to the side of the case. The single lug is located at the center of gravity of the bomb. Double suspension lugs are located diametrically opposite the single lug and are on a line parallel to the axis of the bomb. They are 14 inches apart on 500-lb and 1000-lb bombs and 30 inches apart on the 2000-lb SAP Bomb M103.

Safety Precautions

The SAP bomb and its components are shipped separately and are assembled before flight. The preparation of bombs for flight requires extreme care, because a mis-step may prove fatal. Bombs assembled with long-delay tail fuzes are particularly hazardous because these fuzes incorporate an anti-withdrawal device. Any attempt to unscrew these fuzes from a bomb will result in the functioning of the anti-withdrawal mechanism, and instantaneous detonation. This type of fuze is particularly responsive to shock and temperature change. Bombs of the semi-armor-piercing series can be fitted with this type of fuze. When using such fuzes, it is imperative that fuzes not be assembled to bombs in anticipation of future needs.

Nothing should be taken for granted; every step must be checked and double-checked. Follow assembly instructions carefully.

Safety Precautions To Be Observed

1. Fuzes and bombs shall not be unpacked in advance of requirements; they shall be returned to their original packings, if not used.

2. Any accidentally armed fuzes, either fully or partially armed, must never be handled except by authorized personnel. The fuzes if installed may detonate the bomb.

3. Fuzes shall not be assembled to bombs in anticipation of future needs.

4. Protect long-delay tail fuzes (M124A1 and M125A1) from heat and shock.

5. Guard fuzes against dropping or bumping at all times, to prevent accidental detonation.

6. Never allow primer detonators to drop or strike an object; they are extremely sensitive and rough handling may cause them to explode.

7. Examine temperature indicator vials when the fuze packing is opened. If all fuzes in the box are not used, the vials shall be left in the box with the remaining fuzes and inspected again when box is reopened.

8. Screw fuzes into bombs **HANDTIGHT ONLY**. Never use a tool, unless authorized.

9. USE A "SCREWING-IN" MOTION ONLY WHEN INSTALLING LONG-DELAY TAIL FUZES.

10. Handle and install arming vanes with

care to prevent distortion of blades and the malfunction of both fuze and bomb.

11. Never remove a warning tag from a fuze when it is installed in a bomb.

12. Never defuze a bomb equipped with an anti-withdrawal device; it is certain to detonate. Authorized personnel only shall destroy both bomb and fuze.

13. Never remove safety cotter pins or car seals from fuzes prematurely.

14. All safety pins must be replaced when defuzing a bomb.

15. Do not use a fin assembly if it cannot be secured to the bomb properly. If fin assembly is loose and turns on the bomb, it will pull the arming wire from the tail fuze, causing the fuze to arm before the bomb is dropped.

16. Never use an arming wire with kinks, twists, or burrs.

Section 3.2—500-lb SAP Bombs AN-M58A2, AN-M58, and AN-M58A1

Description

The 500-lb SAP Bomb AN-M58A2, figure 3.2, has a cylindrical, heavy metal casing with a pointed nose. A box-type fin assembly is attached to the aft end of the bomb body by a fin locknut. The base plug of AN-M58A2 locks securely in place, and the adapter-booster may be locked to the base plug.

This bomb accommodates both nose and tail fuzes. Tactical requirements usually nullify the need for a nose fuze; in which case, the nose fuze cavity is fitted with a solid steel plug. The 500-lb SAP Bomb AN-M58A2 was developed to provide greater penetrative ability than that afforded by a comparable weight general purpose bomb.

Suspension lugs for either single or double point suspension are welded to the bomb body. Yellow bands on the nose and aft end of the bomb body identify the explosive charge. Identifying nomenclature is stenciled in black on the olive-drab painted bomb casing. Picratol and TNT fillers account for the difference in released weights.

Differences Between Bombs AN-M58A2, AN-M58A1, and AN-M58

Bombs AN-M58A2, AN-M58A1, and AN-M58 are similar to each other in outward appearance. AN-M58A2 contains anti-withdrawal pins in the base plug, and an adapter-booster which can be locked in place. Bombs AN-M58 and AN-M58A1 lack these features.

The three bombs also differ in their released weights. AN-M58 has a lighter body than its two modifications. The complete round weighs 480 pounds, of which 154.6 pounds (32.3 percent of the total bomb weight) is explosive filler. AN-M58A1 weighs 499.5 pounds as released; its explosive filler weighs 145.1 pounds (29 percent of the total bomb weight).

Physical Characteristics of SAP Bomb AN-M58A2

- Weight of assembled fuzeed bomb:
- Loaded with Picratol_ 554.0 lbs
- Loaded with TNT_ _ _ 552 lbs

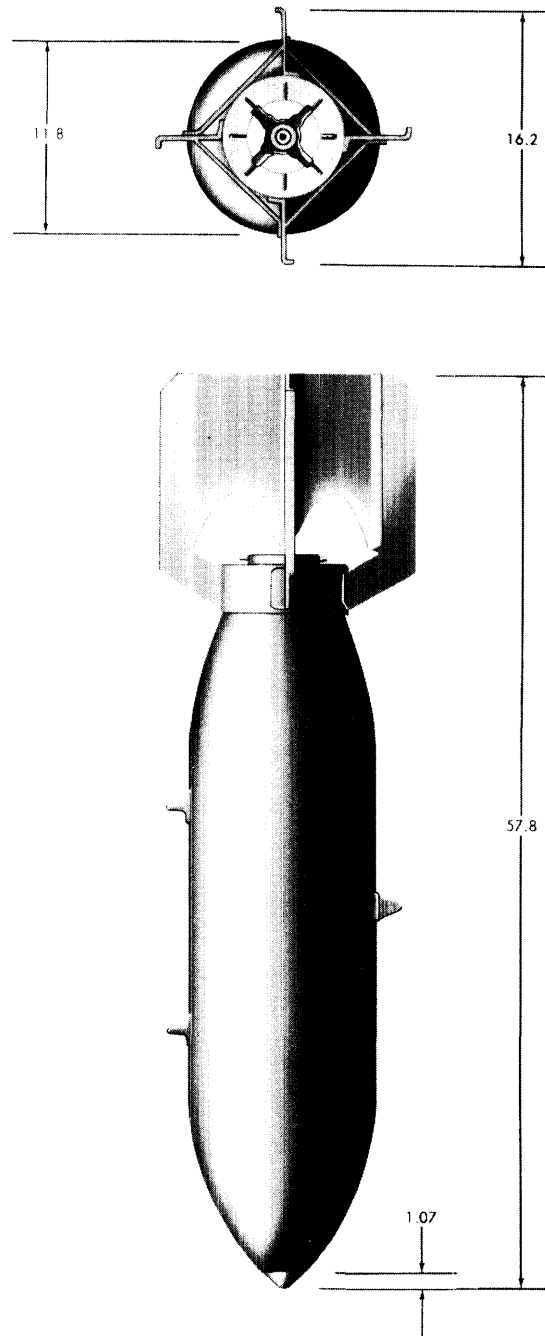

Figure 3.2—500-lb SAP Bomb AN-M58A2.

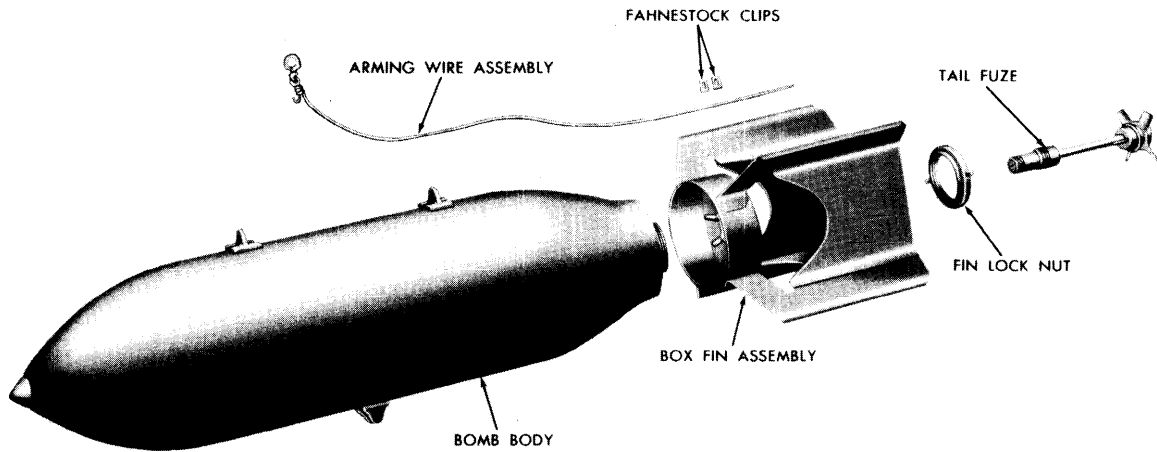

Figure 3.3—500-lb SAP Bomb AN-M58A2, Exploded View.

Weight of explosive:

- Picratol 154 lbs
- TNT 152 lbs

Weight of fin:

- Fin Assembly AN- 17.5 lbs
- M110A1

Dimensions:

- Length of complete bomb 57.8 inches
- Length of bomb body 45 inches
- Diameter 11.8 inches
- Fin span 16.2 inches
- Fin length 15.05 inches

Suspension:

- Two suspension lugs 14 inches c to c
- Single suspension lug Center of gravity

Components of a Complete Round (Figures 3.3 and 3.4)

Bomb body assembly (including):

- Bomb body
- Fin locknut
- Closing plugs

Fin Assembly AN-M110A1

Fahnestock clips

Tail fuze (one of):

- M116
- M124A1
- M133

AN-M101A2

Nose fuze (one of):

- AN-M103A1
- AN-M139A1
- AN-M140A1

Arming Wire Assembly Mk 1 or AN-M6A2

Assembly

CAUTION: Fuzes and bombs shall not be unpacked in advance of requirements and shall be returned to their original packings, if not used.

1. Remove shipping bands from bomb by removing nuts from securing bolts. Remove closing plugs.

CAUTION: Inspect for damage (cracks, broken weldments, etc.) which might weaken lugs or their attachment to the bomb body.

2. Cut the shipping wire, and remove fin locknut and its protector. Remove protector from locknut.

3. Remove fin assembly and attachments from shipping crate. Place fin assembly over end of bomb with one fin in line with suspension lugs. If suspended in external racks, locate fin to clear aircraft structure and ground, when installed. Replace fin locknut and tighten with wrench. When bomb is to be carried

externally at speeds in excess of 350 knots, Fin Lock Nut Mk 1 Mod 0 should be used in place of the regular fin locknut. This is necessary to prevent rotation of the fin assembly.

CAUTION: Do not use a fin assembly if it cannot be secured to the bomb properly. If the fin assembly is loose and turns on the bomb, it will pull the arming wire from the tail fuze, causing it to arm prematurely.

4. Install bomb on aircraft and securely lock in place. If bomb bay does not provide enough space for fuzing, fuzing shall be done prior to hoisting bomb into place on the rack.

5. Remove required number of fuzes and arming wire assemblies from their containers.

CAUTION: If containers are punctured, split, or if the seal is broken in any way, the fuzes contained therein shall be considered unserviceable. This does not apply to fuzes repacked in the field and resealed with adhesive tape for temporary protection. These

fuzes should be examined carefully for serviceability.

6. For detailed information on fuzing and defuzing, refer to OP 988 (First Revision).

CAUTION: One of the fuzes with this bomb is Tail Fuze M124A1 which incorporates an anti-withdrawal device. Non-detonation of bombs fuzed with the M124A1 when released "SAFE" cannot be relied upon, because the glass solvent ampule in the fuze may be broken upon impact of the bomb. Once Fuze M124A1 is installed, never attempt to remove fuze from the bomb or to return the bomb to an airfield or aircraft carrier, upon an incomplete mission. Do not turn Fuze M124A1 back and forth to engage threads; use a "screwing-in" motion only. The anti-withdrawal device will cause the fuze and bomb to detonate if the fuze is rotated counterclockwise while in the adapter-booster, even before threads are engaged.

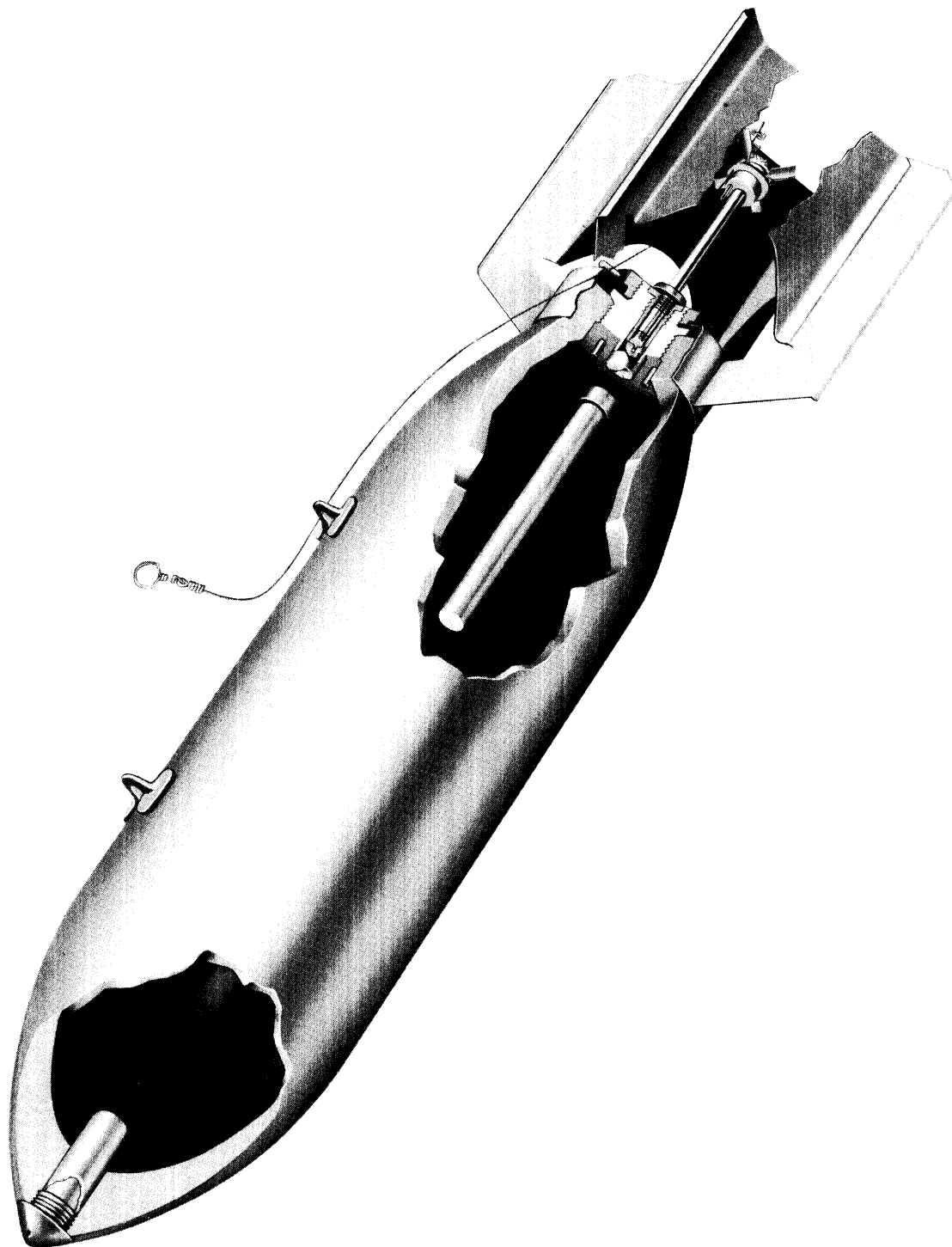

Figure 3.4—500-lb SAP Bomb AN-M58A2, Cutaway View.

Section 3.3—1000-lb SAP Bombs AN-M59A1 and AN-M59

Description

The 1000-lb SAP Bomb AN-M59A1, figure 3.5, is a heavy nosed, cylindrical-shaped bomb. Its thick metal body is designed to give greater penetration than a general purpose bomb of comparable weight. A box-type fin assembly is attached to the aft end by a fin locknut. The base plug of Bomb AN-M59A1 locks securely in place, and the adapter-booster may be locked to the base plug.

This bomb can accommodate both nose and tail fuzes. Tactical requirements usually nullify the need for a nose fuze; in which case, the nose fuze cavity is fitted with a solid steel plug. Approximately 30 percent of the total weight of the 1000-lb SAP Bomb AN-M59A1 is explosive charge.

Differences Between Bombs AN-M59 and AN-M59A1

The 1000-lb SAP Bomb AN-M59A1 has anti-withdrawal pins in the base plug, and an adapter-booster which can be locked to the base plug. Bomb AN-M59 lacks these features. The explosive charge in Bomb AN-M59 is approximately 315 pounds or 31.8 percent of the total bomb weight of 990 pounds. In all other physical aspects the 1000-lb SAP Bomb AN-M59 is identical to the 1000-lb SAP Bomb AN-M59A1.

Physical Characteristics of Bomb AN-M59A1

- Weight of assembled fuzeed bomb:
 - Loaded with Picratol... 1041.9 lbs
 - Loaded with TNT..... 1036.0 lbs
- Weight of explosive:
 - Picratol..... 320.0 lbs
 - TNT..... 315.0 lbs
- Weight of fin:
 - Fin Assembly AN-M114A1..... 25.5 lbs
- Dimensions:
 - Length of complete bomb..... 70.38 inches
 - Length of bomb body... 55.5 inches

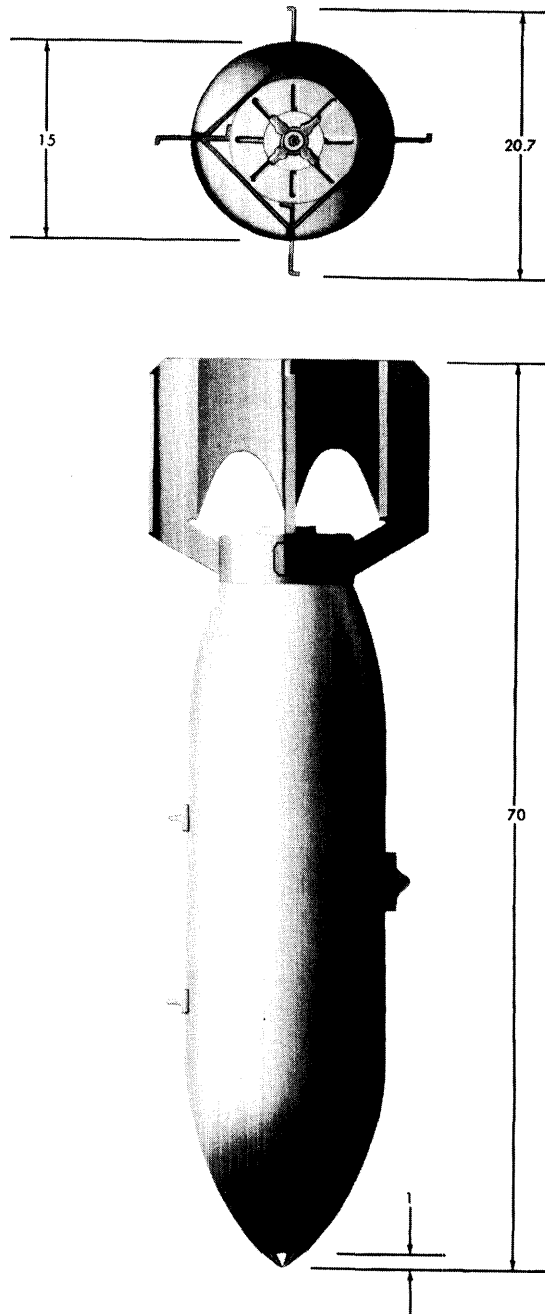

Figure 3.5—1000-lb SAP Bomb AN-M59A1.

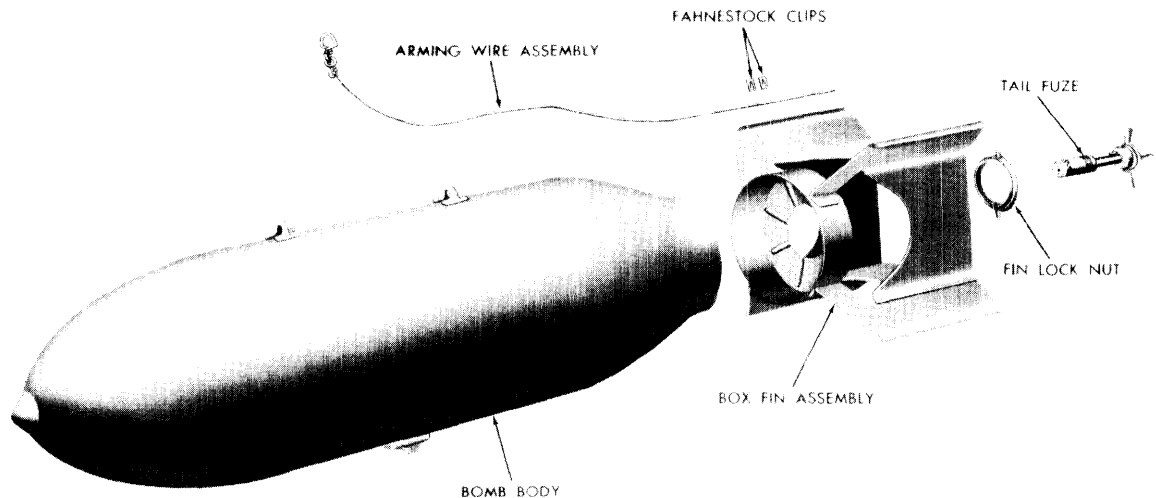

Figure 3.6—1000-lb SAP Bomb AN-M59A1, Exploded View.

Dimensions—Continued

Diameter.....	15.13 inches
Fin span.....	20.7 inches
Fin length.....	16.8 inches

Suspension:

Two suspension lugs...	14 inches c to c
Single suspension lug...	Center of gravity

Components of a Complete Round (Figures 3.6 and 3.7)

Bomb body assembly (including):

- Bomb body
- Fin locknut
- Closing plugs

Fin Assembly AN-M114A1

Tail fuze (one of):

- AN-M102A2
- M117
- M125A1
- M134

Nose fuze (one of):

- AN-M103A1
- AN-M139A1
- AN-M140A1

- Arming Wire Assembly Mk 1 or AN-M6A2
- Fahnestock clips

Assembly

CAUTION: Fuzes and bombs shall not be unpacked in advance of requirements and shall be returned to their original packings, if not used.

1. Remove shipping bands from bomb by removing nuts from securing bolts. Remove closing plugs.

CAUTION: Inspect for damage, (cracks, broken weldments, etc.) which might weaken lugs or their attachment to the bomb body.

2. Cut the shipping wire, and remove fin locknut and its protector. Remove protector from locknut.

3. Remove fin assembly and attachments from shipping crate. Place fin assembly over end of bomb with one fin in line with suspension lugs. If suspended in external racks, turn fin and locate to clear aircraft structure and ground when installed. Replace fin locknut and tighten with wrench. When bomb is to be carried externally at speeds in excess of 350 knots, Fin Lock Nut Mk 1 Mod 0 should be used in place of the regular locknut. Setscrews should be

securely tightened. This is necessary to prevent rotation of the fin assembly.

CAUTION: Do not use fin assembly if it cannot be secured to the bomb properly. If the fin assembly is loose and turns on the bomb, it will pull the arming wire from the tail fuze, causing it to arm prematurely.

4. Install bomb on aircraft and securely lock in place. If bomb bay does not provide enough space for fuzing, fuzing shall be done prior to hoisting bomb into place on the rack.

5. Remove required number of fuzes and arming wire assemblies from their containers.

CAUTION: If containers are punctured, split, or if the seal is broken in any way, the fuzes contained therein shall be considered unserviceable. This does not apply to fuzes repacked in the field and resealed with adhesive tape for temporary protection. These fuzes should be examined carefully for serviceability.

6. For detailed instructions on fuzing and defuzing, refer to OP 988 (First Revision).

CAUTION: Bomb AN-M59A1 uses Tail Fuze M125A1 or M134 which incorporates an anti-withdrawal device. Non-detonation of bombs fuzed with Fuze M125A1 or M134 when release "SAFE" cannot be relied upon, because the glass solvent ampule in the fuze may be broken upon impact of the bomb. Once Fuze M125A1 or M134 is installed, never attempt to remove the fuze or to return the bomb to an airfield or aircraft carrier, upon an incomplete mission. Do not turn Fuze M125A1 or M134 back and forth to engage threads; use a "screwing-in" motion only. The anti-withdrawal device will cause the fuze and bomb to detonate if the fuze is rotated counter-clockwise while in the adapter-booster, even before threads are engaged.

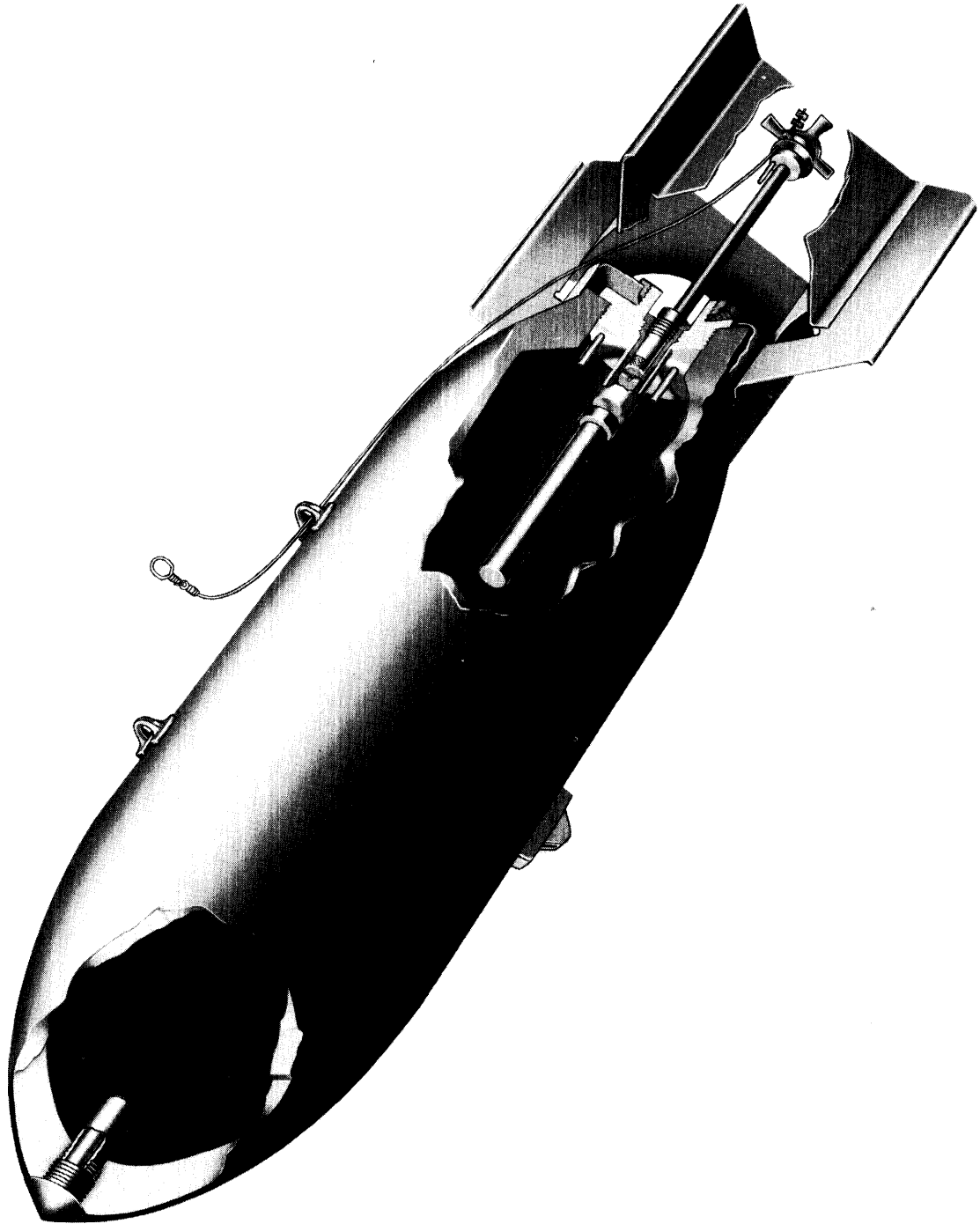

Figure 3.7—1000-lb SAP Bomb AN-M59A1, Cutaway View.

Section 3.4—2000-lb SAP Bomb M103

Description

The 2000-lb SAP Bomb M103, figure 3.8, is fabricated from seamless steel tubing and has a solid, semi-pointed nose. This bomb uses only a tail fuze; it has no provision for a nose fuze. A box-type fin assembly is used as on other SAP bombs.

Approximately 27 percent of the total weight of the 2000-lb SAP Bomb M103 is explosive filler, Picratol. Double suspension lugs having a 30-inch spacing are welded to the bomb casing. A single lug is located on the side opposite the double lugs.

Yellow bands on the nose and aft end of the body identify the high-explosive charge. Identifying nomenclature is stenciled in black on the olive-drab painted bomb casing.

Physical Characteristics

- Weight of assembled fuzed bomb:
 - Loaded with Picratol... 2039.35 lbs
- Weight of explosive:
 - Picratol..... 556.48 lbs
- Weight of fin:
 - Fin Assembly M117A1.. 52.75 lbs
- Dimensions:
 - Length of complete bomb 88.5 inches
 - Length of bomb body.. 66.3 inches
 - Diameter..... 18.75 inches
 - Fin span..... 25.84 inches
 - Fin length..... 25.68 inches
- Suspension:
 - Two suspension lugs... 30 inches c to c
 - Single suspension lug.. Center of gravity

Components of a Complete Round (Figures 3.9 and 3.10)

- Bomb body assembly (including):
 - Bomb body
 - Fin locknut
 - Closing plug
- Fin Assembly M117A1
- Tail fuze (one of):
 - AN-M102A2
 - M117
 - M125A1
 - M134

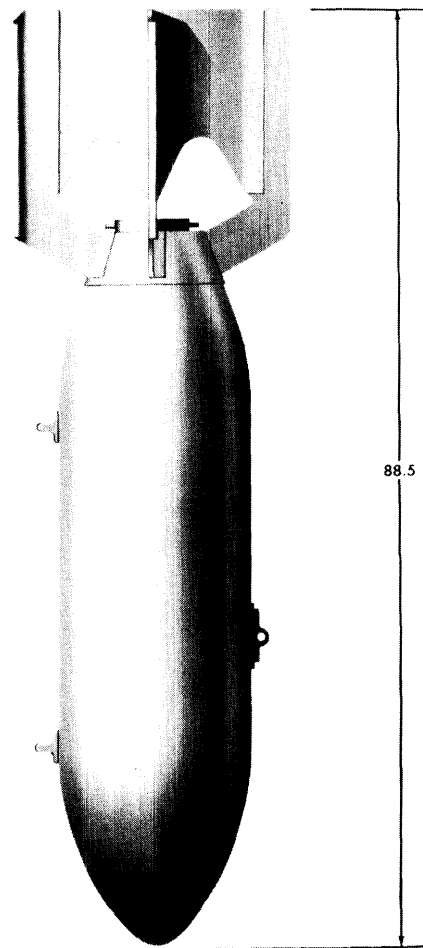
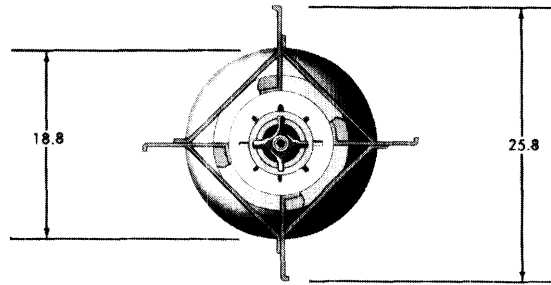

Figure 3.8—2000-lb SAP Bomb M103.

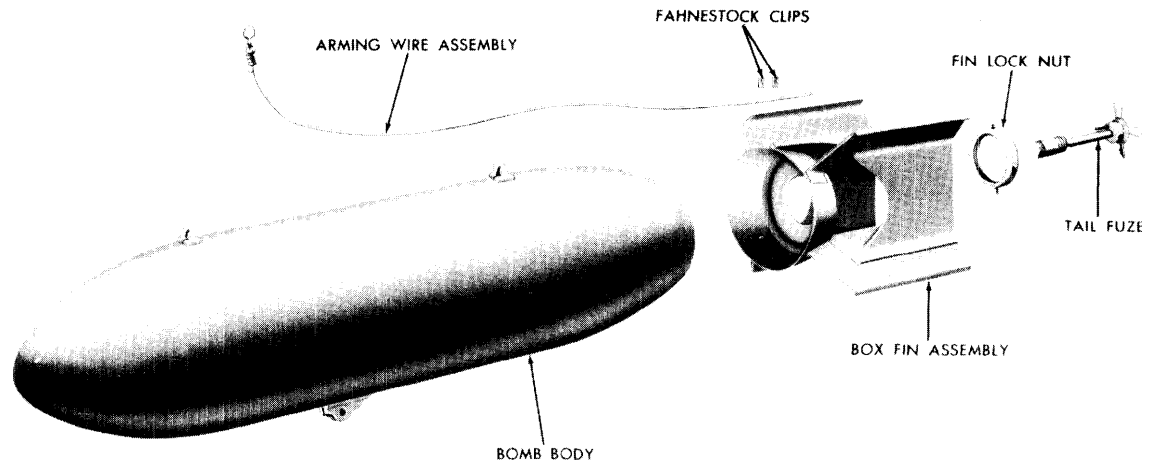

Figure 3.9—2000-lb SAP Bomb M103, Exploded View.

Arming Wire Assembly M9

Fahnestock clips

Assembly

CAUTION: Fuzes and bombs shall not be unpacked in advance of requirements. Return them to their original packings, if not used.

1. Remove shipping bands from bomb by removing nuts from securing bolts. Remove closing plugs.

CAUTION: Inspect for damage (cracks, broken weldments, etc.) which might weaken lugs or their attachment to the bomb body.

2. Cut the shipping wire, and remove fin locknut and its protector. Remove protector from locknut.

3. Remove fin assembly and attachments from shipping crate. Place fin assembly over end of bomb with one fin in line with suspension lugs. If suspended in external racks, turn fin and locate to clear aircraft structure and ground, when installed. Replace fin locknut and tighten with wrench.

CAUTION: Do not use fin assembly if it cannot be secured to the bomb properly. If the fin assembly is loose and turns on the bomb, it will pull the arming wire from the tail fuze, causing it to arm prematurely.

4. Install bomb on aircraft and lock securely

in place. If bomb bay does not provide enough space for fuzing, fuzing shall be done prior to hoisting bomb into place on the rack.

5. Remove required number of fuzes and arming wire assemblies from their containers.

CAUTION: If containers are punctured, split, or if the seal is broken in any way, the fuzes contained therein shall be considered unserviceable. This does not apply to fuzes repacked in the field and resealed with adhesive tape for temporary protection. These fuzes should be examined carefully for serviceability.

6. For detailed information on fuzing and defuzing, refer to OP 988 (First Revision).

CAUTION: Tail Fuzes M125A1 and M134 incorporate an anti-withdrawal device. Non-detonation of bombs fuzed with Fuze M125A1 or M134 when released "SAFE" cannot be relied upon, because the glass solvent ampule in the fuze may be broken upon impact of the bomb. Once Fuze M125A1 or M134 is installed, never attempt to remove fuze from the bomb or to return the bomb to an airfield or aircraft carrier, upon an incomplete mission. Do not turn Fuze M125A1 or M134 back and forth

to engage threads; use a "screwing-in" motion only. The anti-withdrawal device will cause the fuze and bomb to

detonate if the fuze is rotated counter-clockwise while in the adapter-booster, even before threads are engaged.

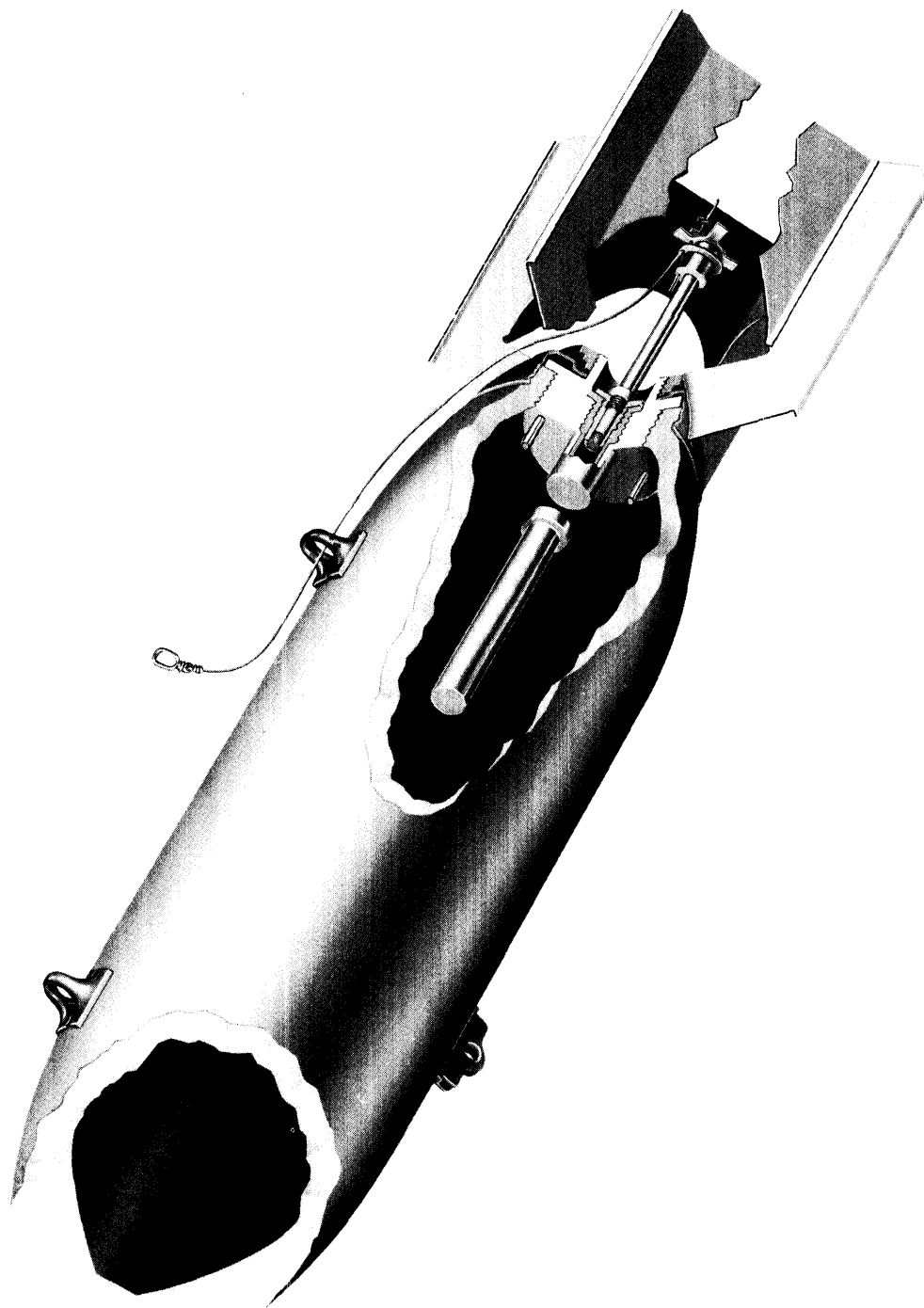

Figure 3.10—2000-1b SAP Bomb M103, Cutaway View.

Chapter 4

GENERAL PURPOSE BOMBS

Section 4.1—General

Section 4.2—100-lb GP Bomb AN-M30A1 with Fin Assembly AN-M103A1

Section 4.3—100-lb GP Bomb AN-M30A1 with Fin Assembly M135 (T144)

Section 4.4—250-lb GP Bomb AN-M57A1 with Fin Assembly AN-M106A1

Section 4.5—250-lb GP Bomb AN-M57A1 with Fin Assembly M126 (T147)

Section 4.6—500-lb GP Bomb AN-M64A1 with Fin Assembly AN-M109A1

Section 4.7—500-lb GP Bomb AN-M64A1 with Fin Assembly M128A1 (T127)

Section 4.8—1000-lb GP Bomb AN-M65A1 with Fin Assembly AN-M113A1

Section 4.9—1000-lb GP Bomb AN-M65A1 with Fin Assembly M129 (T142)

Section 4.10—2000-lb GP Bomb AN-M66A2 with Fin Assembly AN-M116A1

Section 4.11—2000-lb GP Bomb AN-M66A2 with Fin Assembly M130 (T143)

Chapter 4

GENERAL PURPOSE BOMBS

Section 4.1—General

Description

The general purpose (GP) bombs described in this chapter have a cylindrical metal body with an ogival nose and a tapered aft section. These bombs can accommodate both nose and tail fuzes and usually are fuzed in this manner for most bombing operations; the one major exception is when chemical, long-delay tail fuzes are installed. In this case, the nose fuze is not assembled to the bomb, and the nose fuze cavity is fitted with a nose plug.

Either the standard box-type fin assemblies or the newer conical fin assemblies are used on the GP bomb series. For external suspension, the fins are constructed of heavy gage metal. The conical fin assemblies give added length to the bombs, necessitating the use of the new long-stem tail fuzes.

Approximately 50 percent of the total weight of a GP bomb is explosive filler. This high charge-weight ratio makes GP bombs highly effective for demolition operations. The bursting charge may be Amatol 50/50, Composition B, Tritonal, or TNT.

Usage

The high charge-weight ratio of GP bombs makes them suitable for the majority of the bombing situations; hence, the term GENERAL PURPOSE. The relatively thin walls reduce or nullify the effectiveness of this type of bomb when used against moderate to heavy reinforced concrete or armor; in which case, the bomb breaks up or explodes before penetration.

General Purpose Bombs (Figure 4.1)

100-lb GP Bombs AN-M30A1 and AN-M30
 250-lb GP Bombs AN-M57A1 and AN-M57
 500-lb GP Bombs AN-M64A1 and AN-M64
 1000-lb GP Bombs AN-M65A1 and AN-M65
 2000-lb GP Bombs AN-M66A2, AN-M66A1
 and AN-M66

CONFIDENTIAL

Fuzes Compatible with General Purpose Bombs

Tail fuzes:

AN-M100A2
 AN-M101A2
 AN-M102A2
 M115
 M116
 M117
 M123A1
 M124A1
 M125A1
 M132
 M133
 M134

Nose fuzes:

AN-M103A1
 AN-M139A1
 AN-M140A1
 Mk 243 Mod 0
 Mk 244 Mod 1
 VT Fuze AN-M166
 VT Fuze AN-M168

Tail fuzes (long-stem) for conical fin installations:

M172
 M175
 M176
 M177
 M184 (T739)
 M185 (T740)
 T753
 T754
 T755
 T756
 T757
 T758
 M181 (T781)
 M182 (T782)
 M183 (T783)

Markings

GP bombs are identified by standard nomenclature and yellow bands located on an olive-drab painted casing.

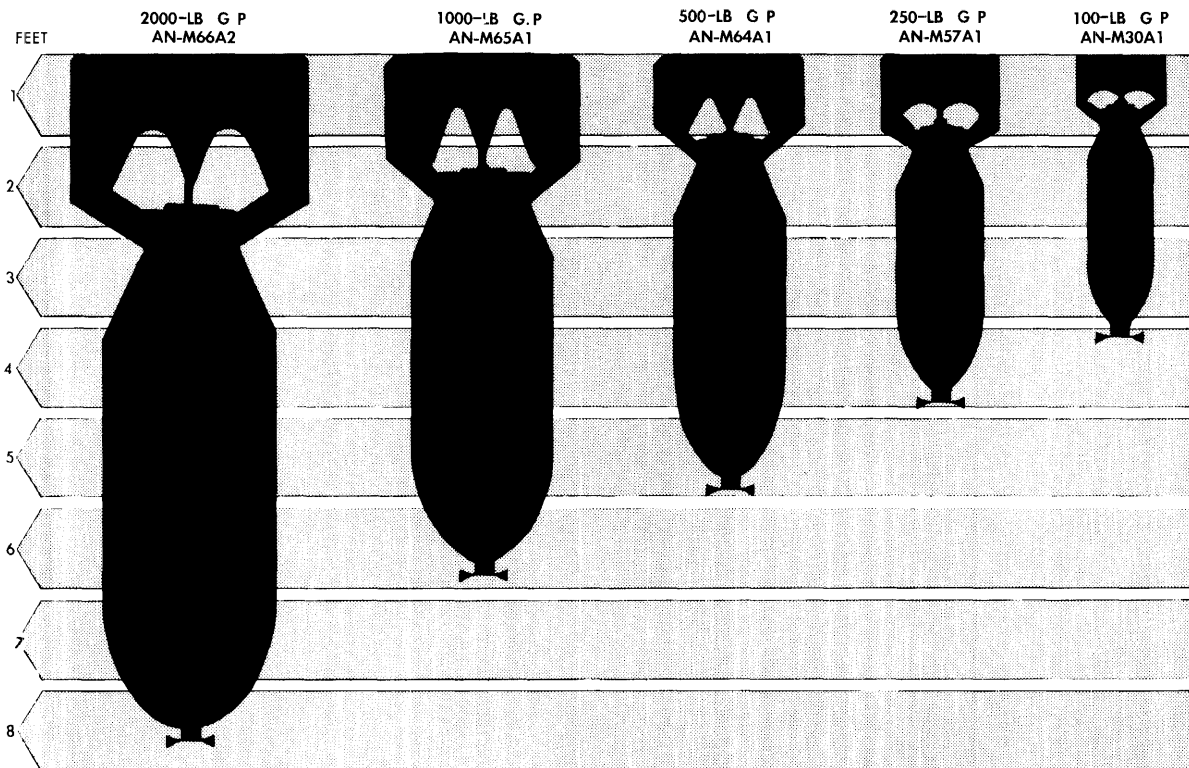

Figure 4.1—General Purpose Bombs, Comparative Size.

The following identifying information is stenciled in black on the bomb case:

- Type
- Weight
- Model
- Filler—(Tritonal, TNT, Amatol, or Comp B)
- Ammunition lot number
- “US” in letters
- Inspector’s stamp
- AIC symbol
- Explosive bomb with pads
- ICC shipping designation
- Displacement (cubic feet)
- Address
- Shipping ticket number

Bomb components and packing are identified completely by standard nomenclature and ammunition lot number, stenciled in black on all packings or items.

Suspension

General purpose bombs are provided with both single and double suspension lugs welded to the case. The single lug is located on the side of the bomb case opposite the double sus-

pension lugs. On the smaller-sized GP bombs, 1000-lb and below, the lugs are spaced 14 inches apart; on the 2000-lb GP bomb, they are spaced 30 inches apart.

Safety Precautions

The GP bomb and its components are shipped separately and are assembled before flight. The preparation of bombs for flight requires extreme care because a mis-step may prove fatal. Bombs assembled with long-delay tail fuzes are particularly hazardous, because such fuzes incorporate an anti-withdrawal device. Any attempt to unscrew these fuzes from a bomb will result in the functioning of the anti-withdrawal mechanism, and instantaneous detonation of the bomb. This type of fuze is particularly responsive to shock and temperature change. Bombs of the general purpose (GP) series can be fitted with this type of fuze. When using these fuzes, it is imperative that fuzes not be assembled to bombs in anticipation of future needs.

Procedures should be checked and double-checked; FOLLOW ASSEMBLY INSTRUCTIONS CAREFULLY.

Safety Precautions To Be Observed

1. Fuzes and bombs shall not be unpacked in advance of requirements and shall be returned to their original packings, if not used.
2. Any accidentally armed fuze, even if only partially armed, must be handled by authorized personnel only. The fuze, if installed, may detonate the bomb.
3. Fuzes shall not be assembled to bombs in anticipation of future needs.
4. Protect long-delay tail fuzes (M123A1 and M132 series) from heat and shock.
5. Guard fuzes against dropping or bumping at all times to prevent accidental detonation.
6. Never allow primer detonators to drop or strike an object; they are extremely sensitive and rough handling may explode them.
7. Examine temperature indicator vials when the fuze packing is opened. If all fuzes in the box are not used, the vials shall be left in the box and inspected again when the box is reopened.
8. Screw fuzes into bombs **HANDTIGHT ONLY**. Use only authorized tools.
9. Use a "screwing-in" motion only when installing a long-delay tail fuze.
10. Handle and install fuze arming vanes carefully to prevent distortion of blades.
11. Do **NOT** remove warning tag after fuze is installed in bomb.
12. Never defuze a bomb equipped with an anti-withdrawal fuze; it is certain to detonate. Authorized personnel shall destroy both bomb and fuze. Refer to NAVORD Instruction 8150.1.
13. Never remove safety cotter pins or car seals from fuzes prematurely.
14. Replace all safety pins before defuzing a bomb.
15. Do not use a fin assembly if it cannot be secured to the bomb properly. If fin assembly is loose and turns on the bomb, it may pull the arming wire from the tail fuze, allowing the fuze to arm before the bomb is dropped.
16. Inspect arming wires for kinks, twists, and burrs. Defective arming wires may cause the bomb to malfunction.

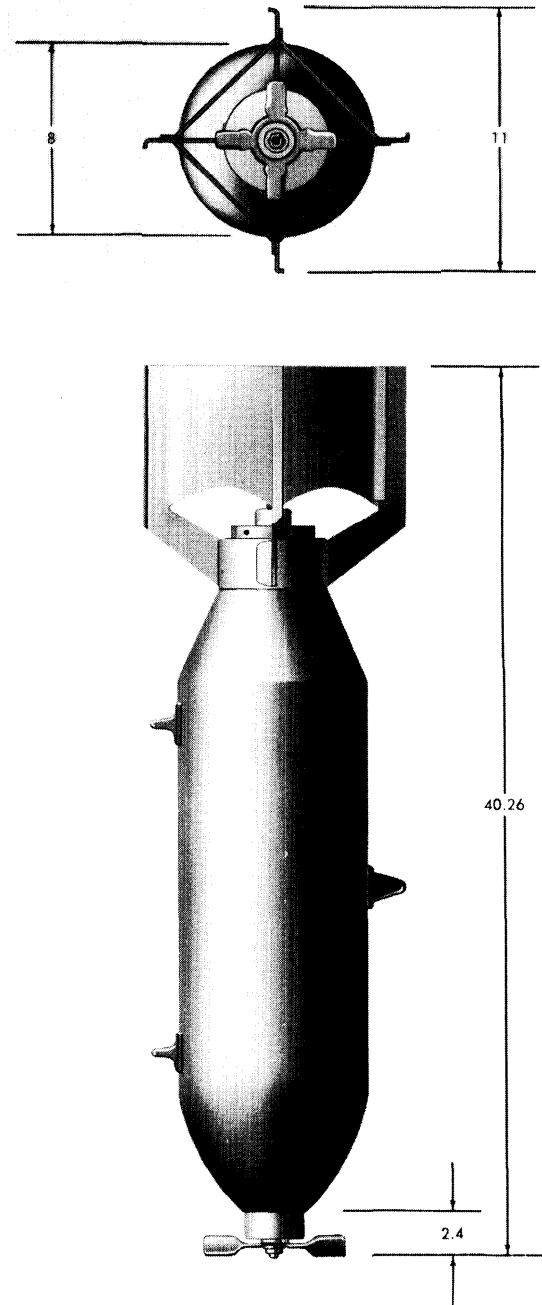

Figure 4.2—100-lb GP Bomb AN-M30A1 with Fin Assembly AN-M103A1.

Section 4.2—100-lb GP Bomb AN-M30A1 with Fin Assembly AN-M103A1

Description

The 100-lb GP Bomb AN-M30A1, figure 4.2, is a relatively thin-cased bomb with an ogival nose, parallel side walls, and a tapered aft section. A box-type fin assembly (AN-M103A1) is fastened to the aft end of the bomb with a fin locknut.

The bomb uses both a nose and a tail fuze. The base plug of Bomb AN-M30A1 is locked securely to the bomb body by two studs which extend from the base plug into the solidified explosive charge. This bomb also provides a means of locking the adapter-booster to the base plug; a locking pin is passed through a hole in the adapter-booster into a groove in the base plug. These modifications prevent removal of the base plug and adapter-booster; thus, the anti-withdrawal devices of long-delay fuzes are more effective.

Double suspension lugs are welded, 14 inches apart, on one side of the bomb body. A single lug is welded to the opposite side at the center

of gravity. Approximately 50 percent of the released bomb weight is its explosive charge of TNT or Tritonal.

Yellow color bands on an olive-drab body identify the high-explosive charge. Identifying nomenclature is stenciled in black paint on the nose, mid-section, and conical aft section.

Differences Between Bombs AN-M30A1 and AN-M30

Bomb AN-M30A1 contains anti-withdrawal pins in the base plug, and a device for locking the adapter-booster to the base plug. The earlier model, AN-M30, does not have these features.

Bomb AN-M30 is lighter in weight than its modification, AN-M30A1. Bomb AN-M30 may be loaded with 105.5 pounds of Tritonal, 102.5 pounds of TNT, or 99.0 pounds of Amatol 50/50. Its total length is 38.46 inches as compared to AN-M30A1 with a length of 43.0 inches.

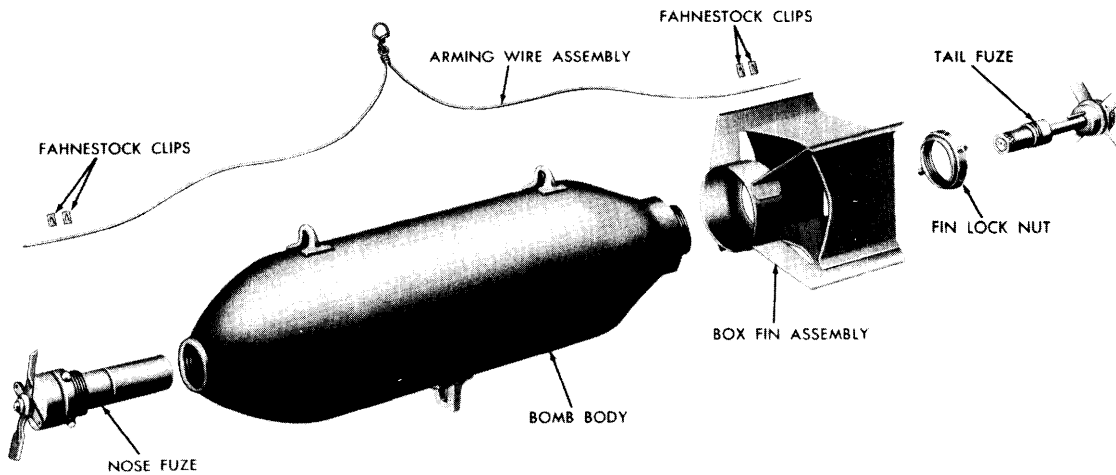

Figure 4.3—100-lb GP Bomb AN-M30A1 with Fin Assembly AN-M103A1, Exploded View.

Physical Characteristics of GP Bomb AN-M30A1 with Fin Assembly AN-M103A1

Weight of assembled fuzed bomb:	
Loaded with TNT	119.5 lbs
Loaded with Tritonal	124.5 lbs
Weight of explosive:	
TNT	57.0 lbs
Tritonal	62.0 lbs
Weight of fin:	
Fin Assembly AN-M103A1	5.6 lbs
Dimensions:	
Length of complete bomb	40.26 inches
Length of bomb body	27.95 inches
Diameter	8.0 inches
Fin span	11.0 inches
Fin length	11.5 inches
Suspension:	
Two suspension lugs	14 inches c to c
Single suspension lug	Center of gravity

Components of a Complete Round (Figures 4.3 and 4.4)

Bomb body assembly (including):	
Bomb body	
Fin locknut (or Fin Lock Nut M1)	
Closing plugs	
Fin Assembly AN-M103A1	
Nose fuze (one of):	
AN-M103A1	
AN-M139A1	
AN-M140A1	
Mk 243 Mod 0	
Mk 244 Mod 1	
VT Fuze AN-M166	
VT Fuze AN-M168	
Tail fuze (one of):	
AN-M100A2	
M115	
M123A1	
M132	
Arming wire assembly	
Fahnestock clips	

Assembly

CAUTION: Fuzes and bombs shall not be unpacked in advance of require-

ments. Return them to their original packings, if they are not used.

1. Remove shipping bands from bomb by removing nut from securing bolts. Remove closing plugs.

CAUTION: Inspect for damage (cracks, broken weldments, etc.) which might weaken lugs or their attachment to the bomb body.

2. Cut the shipping wire, and remove fin locknut and its protector. Remove protector from locknut.

3. Remove fin assembly and attachments from shipping crate. Place fin assembly over end of bomb with one fin in line with suspension lugs. If suspended in external racks, turn fin and locate to clear aircraft structure and ground, when installed. Replace fin locknut and tighten with wrench. When bomb is to be carried externally at speeds in excess of 350 knots, Fin Lock Nut M1 should be used in place of the regular fin locknut. Setscrews should be tightened securely. This is necessary to prevent rotation of the fin assembly. (Refer to NAVORD Instruction 8150.1).

CAUTION: Do not use fin assembly if it cannot be secured to the bomb properly. If the fin assembly is loose and turns on the bomb, it will pull the arming wire from the tail fuze, causing it to arm prematurely.

4. Install bomb on aircraft and securely lock in place. If bomb bay does not provide enough space for fuzing, fuzing shall be done prior to hoisting bomb into place on the rack.

5. Remove required number of fuzes and arming wire assemblies from their containers.

CAUTION: If containers are punctured, split, or if the seal is broken in any way, the fuzes contained therein shall be considered unserviceable. This does not apply to fuzes repacked in the field and resealed with adhesive tape for temporary protection. These fuzes should be examined carefully for serviceability.

6. For detailed information on fuzing and defuzing, refer to OP 988 (First Revision).

CAUTION: Bomb AN-M30A1 uses Tail Fuzes M123A1 or M132 which incorporate an anti-withdrawal device.

Non-detonation of bombs fuzeed with Fuze M123A1 or M132 when released "SAFE" cannot be relied upon, because the glass solvent ampule in the fuze may break upon impact of the bomb. Once Fuze M123A1 or M132 is installed, never attempt to remove the fuze or to return the bomb to an airfield or aircraft carrier, upon an

incomplete mission. Do not turn Fuze M123A1 or M132 back and forth to engage threads; use a "screwing-in" motion only. The anti-withdrawal device will cause the fuze and bomb to detonate if the fuze is rotated counterclockwise while in the adapter-booster, even before threads are engaged.

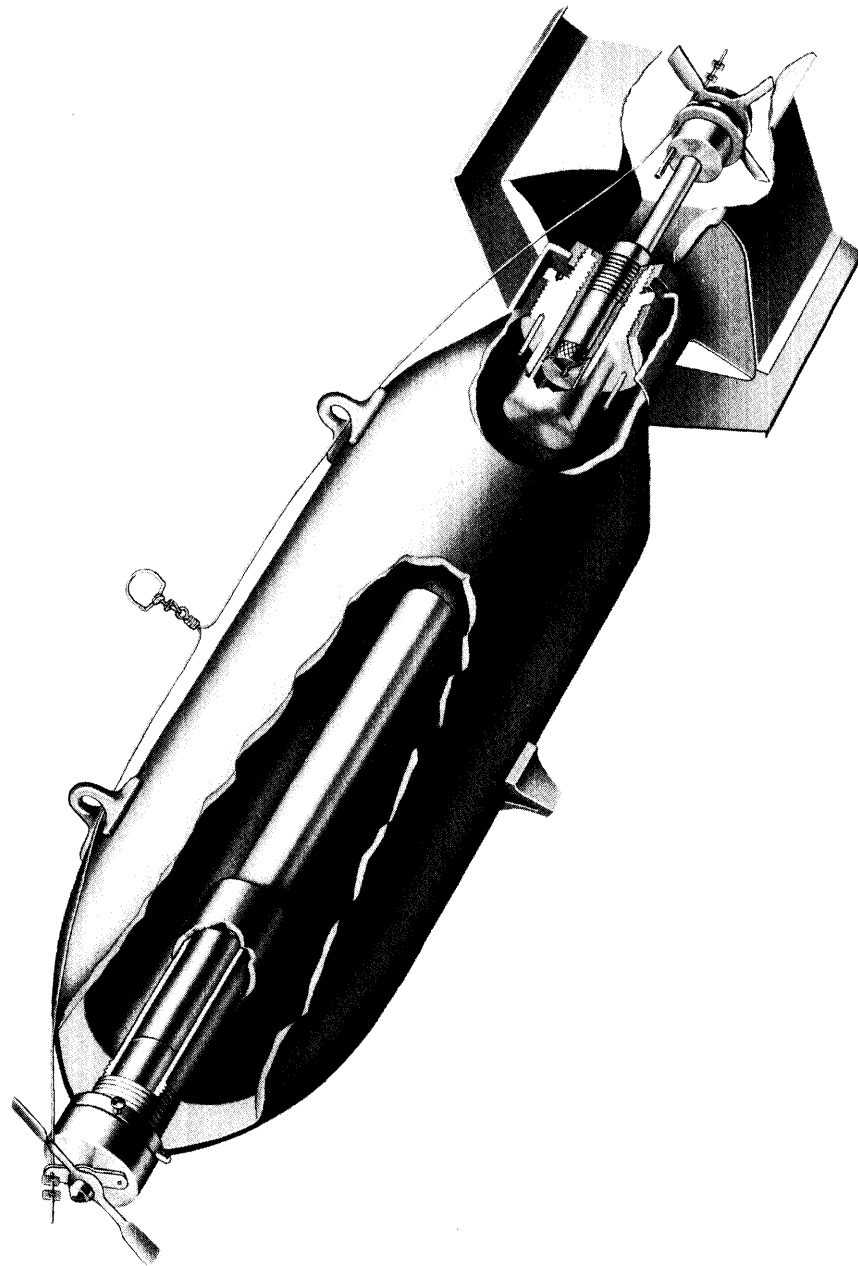

Figure 4.4—100-lb GP Bomb AN-M30A1 with Fin Assembly AN-M103A1, Cutaway View.

Section 4.3—100-lb GP Bomb AN-M30A1 with Fin Assembly M135 (T144)

Description

The 100-lb GP Bomb AN-M30A1, equipped with Fin Assembly M135 (T144), uses the standard Bomb Body AN-M30A1. Fin Assembly M135 consists of an elongated fin cone with four integral fins spaced at equal distances on the cone surface. Conical Fin Assembly M135 was developed to increase aerodynamic performance and accuracy in bombing.

Use of the conical fin lengthens the overall dimension of the 100-lb GP Bomb AN-M30A1. This necessitates the use of a tail fuze with an extra-long arming stem and tube (long-stem fuze) so that the arming vane of the fuze can be located effectively in the airstream.

Physical Characteristics of GP Bomb AN-M30A1 with Fin Assembly M135 (T144)

Weight of assembled fuzed bomb:	
Loaded with TNT	131.5 lbs
Loaded with Tritonal	136.5 lbs
Weight of explosive:	
TNT	57.0 lbs
Tritonal	62.0 lbs

Weight of fin:

Fin Assembly M135 (T144)	17.5 lbs
--------------------------	----------

Dimensions:

Length of a complete bomb	54.2 inches
Length of bomb body	27.95 inches
Diameter	8.0 inches
Fin span	11.18 inches
Fin length	29.0 inches

Suspension:

Two suspension lugs	14 inches c to c
Single suspension lug	Center of gravity

Components of a Complete Round (Figure 4.5)

Bomb body assembly (including):

- Bomb body
- Fin locknut (Supplied with bomb body; to be removed and discarded)
- Closing plugs

Fin Assembly M135 (T144)

Fin Lock Nut (Dwg 1350522)
 Fin Locking Web (BuOrd Sk 329153) } supplied separately.

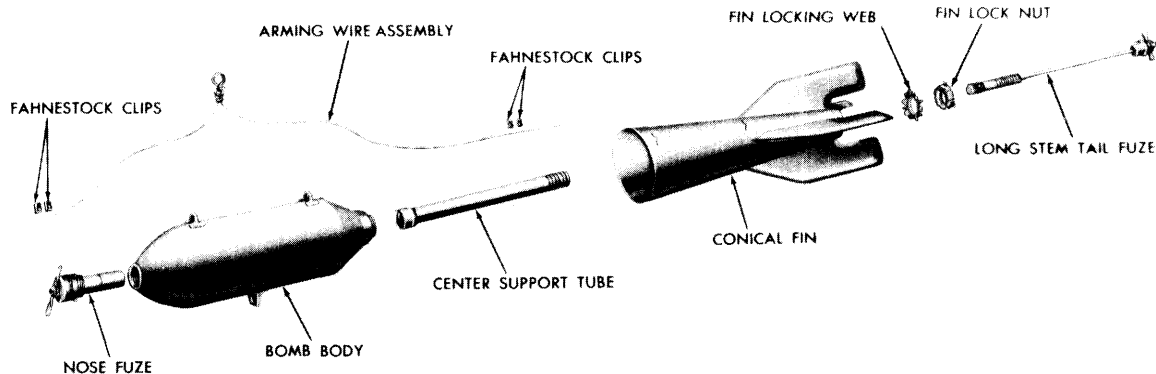

Figure 4.5—100-lb GP Bomb AN-M30A1 with Fin Assembly M135, Exploded View.

Nose fuze (one of):

AN-M103A1
 AN-M139A1
 AN-M140A1
 Mk 243 Mod 0
 Mk 244 Mod 1
 VT Fuze AN-M166
 VT Fuze AN-M168

Tail fuze (one of):

M172
 M175
 T753
 T756
 M181 (T781)

Arming Wire Assembly Mk 1, AN-M6A2,
 or M16

Fahnestock clips

Assembly

CAUTION: Fuzes and bombs shall not be unpacked in advance of requirements and shall be returned to their original packings, if not used.

1. Remove shipping bands from bomb by removing nuts from securing bolts. Remove closing plugs.

CAUTION: Inspect for damage (cracks, broken weldments, etc.) which might weaken lugs or their attachment to the bomb body.

2. Cut the shipping wire. Remove fin locknut and discard it with its protector.

3. Remove fin assembly and attachments from shipping crate. Thread center support tube onto base plug of bomb (locknut seat). Tighten tube with wrench. Tighten setscrews in support tube. Place fin cone over support tube. Slide cone back until jammed against bomb body. Position fins to clear aircraft structure and ground, when installed. Place fin locking web over support tube so that it engages fins of fin assembly. Secure conical fin assembly to support tube by threading on special locknut. (Discard locknut supplied

with fin assembly). Tighten locknut with special notched wrench. Bend two tabs of locking web into locknut slots. Secure nut in position by means of setscrews.

4. Install bomb on aircraft and securely lock in place. If bomb bay does not provide enough space for fuzing, fuzing shall be done prior to hoisting bomb into place on the rack.

5. Remove required number of fuzes and arming wire assemblies from their containers.

CAUTION: If containers are punctured, split, or if the seal is broken in any way, the fuzes contained therein shall be considered unserviceable. This does not apply to fuzes repacked in the field and resealed with adhesive tape for temporary protection. These fuzes should be examined carefully for serviceability.

6. For detailed information on fuzing and defuzing, refer to OP 988 (First Revision).

7. Installation of long-delay Fuzes T753 and T756 with Conical Fin Assembly M135 (T144) requires a special operation to lock each fuze in place. Refer to OP 988 (First Revision).

CAUTION: The 100-lb Bomb AN-M30A1, installed with Fin Assembly M135 (T144), uses Tail Fuzes T753 or T756 which incorporate an anti-withdrawal device. Non-detonation of bombs fuzed with Fuze T753 or T756 when released "SAFE" cannot be relied upon, because the glass solvent ampule may break upon impact of the bomb. Once Fuze T753 or T756 is installed, never attempt to remove the fuze or to return the bomb to an airfield or aircraft carrier, upon an incomplete mission. Do not turn Fuze T753 or T756 back and forth to engage the threads. Use a "screwing-in" motion only. The anti-withdrawal device will cause the fuze and bomb to detonate if the fuze is rotated counterclockwise, even before threads are engaged.

Section 4.4—250-lb GP Bomb AN-M57A1 with Fin Assembly AN-M106A1

Description

The 250-lb GP Bomb AN-M57A1, figure 4.6, is a relatively thin-cased bomb with an ogival nose, parallel side walls, and a tapered aft section. A box-type fin assembly (AN-M106A1) is fastened to the aft end of the bomb with a fin locknut.

A nose and tail fuze are used for the majority of bombing operations. The base plug of Bomb AN-M57A1 is locked securely to the bomb body by two studs which extend from the base plug into the solidified explosive filler. A locking pin is passed through a hole in the adapter-booster into a groove in the base plug. These modifications prevent removal of the base plug and adapter-booster; thus, the anti-withdrawal devices of long-delay fuzes are more effective.

Double suspension lugs are welded to the body 14 inches apart. A single lug is welded to the opposite side of the body at the center of gravity. Approximately 50 percent of the complete round weight is its explosive charge of Amatol 50/50, TNT, or Tritonal.

Yellow bands on an olive-drab body identify the high-explosive charge. Identifying nomenclature is stenciled in black paint on the nose, mid-section, and aft portion of the bomb.

Differences Between Bombs AN-M57A1 and AN-M57

Bomb AN-M57A1 contains anti-withdrawal pins in the base plug, and an adapter-booster which can be locked to the base plug. The earlier model, AN-M57, does not have these features.

Physical Characteristics of GP Bomb AN-M57A1 with Fin Assembly AN-M106A1

Weight of assembled fuzed bomb:	
Loaded with TNT	263.35 lbs
Loaded with Tritonal	272.35 lbs
Weight of explosive:	
TNT	127.0 lbs
Tritonal	136.0 lbs
Weight of fin:	
Fin Assembly AN-M106A1	8.0 lbs

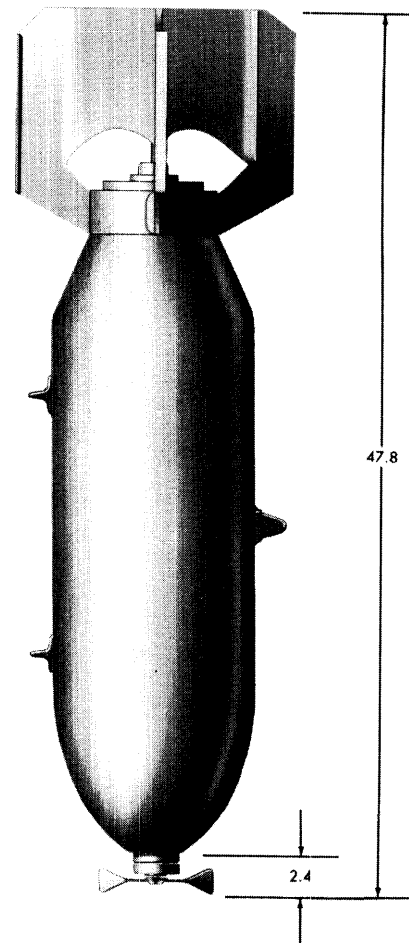
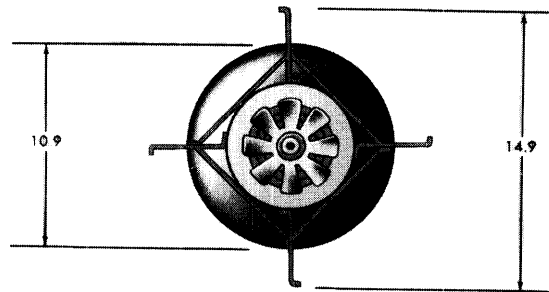

Figure 4.6—250-lb GP Bomb AN-M57A1 with Fin Assembly AN-M106A1.

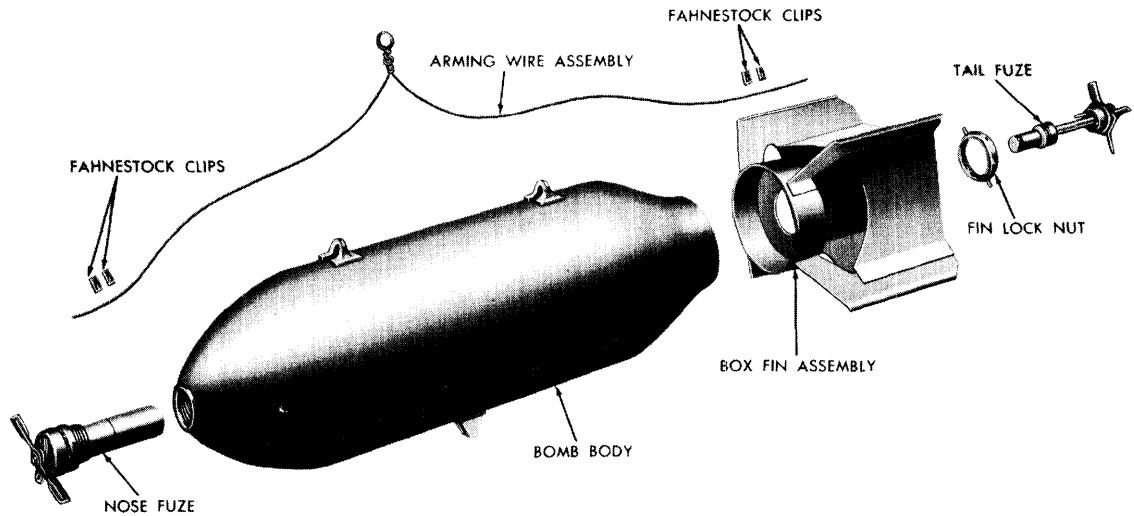

Figure 4.7—250-lb GP Bomb AN-M57A1 with Fin Assembly AN-M106A1, Exploded View.

Dimensions:

Length of complete bomb.....	47.8 inches
Length of bomb body... ..	34.8 inches
Diameter.....	10.8 inches
Fin span.....	14.9 inches
Fin length.....	12.08 inches

Suspension:

Two suspension lugs... ..	14 inches c to c
Single suspension lug... ..	Center of gravity

Components of a Complete Round (Figures 4.7 and 4.8)

Bomb body assembly (including):

- Bomb body
- Fin locknut (or Fin Lock Nut M1)
- Closing plugs

Fin Assembly AN-M106A1

Nose fuze (one of):

- AN-M103A1
- AN-M139A1
- AN-M140A1
- Mk 243 Mod 0
- Mk 244 Mod 1
- VT Fuze AN-M166
- VT Fuze AN-M168

Tail fuze (one of):

- AN-M100A2
- M115
- M123A1
- M132

- Arming wire assembly
- Fahnestock clips

Assembly

CAUTION: Fuzes and bombs shall not be unpacked in advance of requirement. Return them to their original packings, if not used.

1. Remove shipping bands from bomb by removing nuts from securing bolts. Remove closing plugs.

CAUTION: Inspect for damage (cracks, broken weldments, etc.) which might weaken lugs or their attachment to the bomb body.

2. Cut the shipping wire, and remove fin locknut and its protector. Remove protector from locknut.

3. Remove fin assembly and attachments from shipping crate. Position fins to clear aircraft structure and ground, when installed.

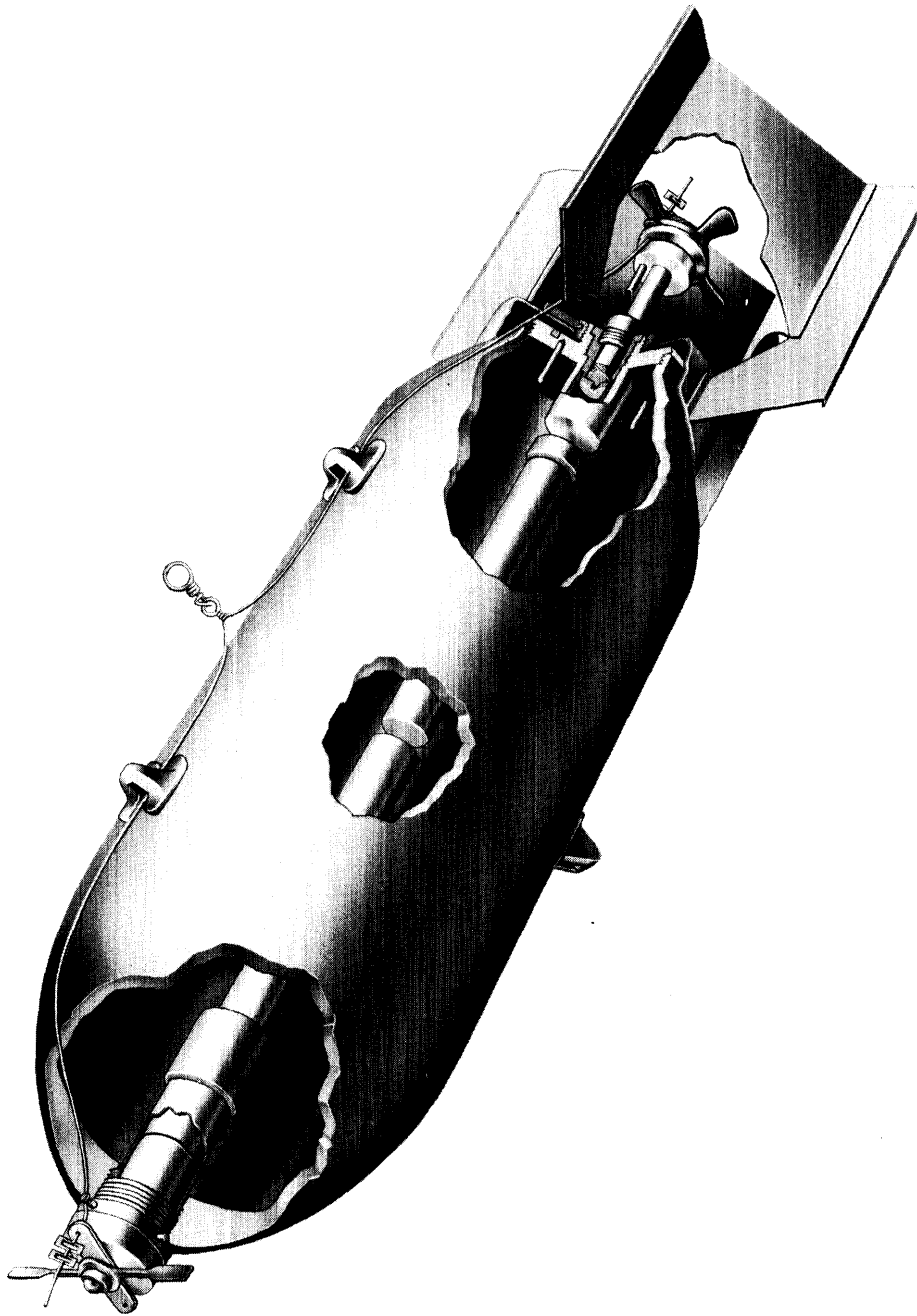

Figure 4.8—250-lb GP Bomb AN-M57A1 with Fin Assembly AN-M106A1, Cutaway View.

When bomb is to be carried externally at speeds in excess of 350 knots, Fin Lock Nut M1 should be used in place of the regular fin locknut. Setscrews should be tightened securely. This is necessary to prevent rotation of the fin assembly. (Refer to NAVORD Instruction 8150.1).

CAUTION: Do not use fin assembly if it cannot be secured to the bomb properly. If the fin assembly is loose and turns on the bomb, it will pull the arming wire from the tail fuze, causing it to arm prematurely.

4. Install bomb on aircraft and securely lock in place. If bomb bay does not provide enough space for fuzing, fuzing shall be done prior to hoisting bomb into place on the rack.

5. Remove required number of fuzes and arming wire assemblies from their containers.

CAUTION: If containers are punctured, split, or if the seal is broken in any way, the fuzes contained therein shall be considered unserviceable. This does not apply to fuzes repacked in the field and resealed with adhesive

tape for temporary protection. These fuzes should be examined carefully for serviceability.

6. For detailed information on fuzing and defuzing, refer to OP 988 (First Revision).

CAUTION: Bomb AN-M57A1 uses Tail Fuzes M123A1 or M132 which incorporate an anti-withdrawal device. Non-detonation of bombs fuzed with Fuze M123A1 or M132 when released "SAFE" cannot be relied upon, because the glass ampule in the fuze may break upon impact of the bomb. Once Fuze M123A1 or M132 is installed, never attempt to remove the fuze or to return the bomb to an airfield or aircraft carrier, upon an incomplete mission. Do not turn Fuze M123A1 or M132 back and forth to engage threads; use a "screwing-in" motion only. The anti-withdrawal device will cause the fuze and bomb to detonate if the fuze is rotated counterclockwise while in the adapter-booster, even before threads are engaged.

Section 4.5—250-lb GP Bomb AN-M57A1 with Fin Assembly M126 (T147)

Description

The 250-lb GP Bomb AN-M57A1 equipped with Fin Assembly M126 (T147) uses the standard Bomb Body, AN-M57A1. The fin assembly consists of an elongated fin cone with four integral fins spaced at equal distances on the cone surface. A support tube runs through the center of the cone, and the fin assembly is secured to the bomb body by means of this support tube, a locking web, and a locknut. The conical fin lengthens the overall dimension of the 250-lb GP Bomb AN-M57A1. This necessitates the use of a long-stem tail fuze so that the arming vane can be located effectively in the airstream. Conical Fin Assembly M126 improves aerodynamic performance and accuracy in bombing.

Physical Characteristics of GP Bomb AN-M57A1 with Fin Assembly M126

Weight of assembled fuzeed bomb:
 Loaded with TNT..... 280.35 lbs
 Loaded with Tritonal. 289.35 lbs
 Weight of explosive:
 TNT..... 127.0 lbs
 Tritonal..... 136.0 lbs

Weight of fin:

Fin Assembly M126 25.0 lbs
 (T147)

Dimensions:

Length of complete bomb 62.2 inches
 Length of bomb body... 34.8 inches
 Diameter..... 10.8 inches
 Fin span..... 15.0 inches
 Fin length..... 30.8 inches

Suspension:

Two suspension lugs... 14 inches c to c
 Single suspension lug... Center of gravity

Components of a Complete Round (Figure 4.9)

Bomb body assembly (including):

Bomb body
 Fin locknut (Supplied with bomb body; to be removed and discarded)
 Closing plugs

Fin Assembly M126 (T147)
 Fin Lock Nut (Dwg 1350522)
 Fin Locking Web (BuOrd Sk 329153) } supplied separately.

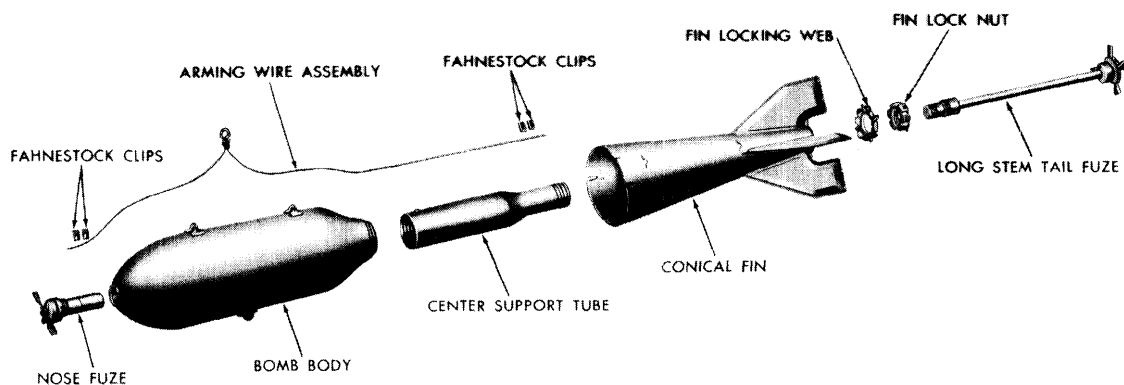

Figure 4.9—250-lb GP Bomb AN-M57A1 with Fin Assembly M126, Exploded View.

Nose fuze (one of):

AN-M103A1
 AN-M139A1
 AN-M140A1
 Mk 243 Mod 0
 Mk 244 Mod 1
 VT Fuze AN-M166
 VT Fuze AN-M168

Tail fuze (one of):

M172
 M175
 T753
 T756
 M181 (T781)

Arming wire assembly

Fahnestock clips

Assembly

CAUTION: Fuzes and bombs shall not be unpacked in advance of requirements and shall be returned to their original packings, if not used.

1. Remove shipping bands from bomb by removing nuts from securing bolts. Remove closing plugs.

CAUTION: Inspect for damage (cracks, broken weldments, etc.) which might weaken lugs or their attachment to the bomb body.

2. Cut the shipping wire. Remove fin locknut and discard it with its protector.

3. Remove fin assembly and attachments from shipping crate. Thread center support tube onto base plug of bomb (locknut seat). Tighten tube with wrench. Tighten setscrews in support tube. Place fin cone over support tube. Slide cone back until jammed against bomb body. Position fins to clear aircraft structure and ground, when installed. Place fin locking web over support tube so that it engages fins of fin assembly. Secure conical fin assembly to support tube by threading on special locknut. (Discard locknut supplied with fin assembly). Tighten locknut with special notched wrench. Bend two tabs of

locking web into locknut slots. Secure nut in position by means of setscrews.

4. Install bomb on aircraft and securely lock in place. If bomb bay does not provide enough space for fuzing, fuzing shall be done prior to hoisting bomb into place on the rack.

5. Remove required number of fuzes and arming wire assemblies from their containers.

CAUTION: If containers are punctured, split, or if the seal is broken in any way, the fuzes contained therein shall be considered unserviceable. This does not apply to fuzes repacked in the field and resealed with adhesive tape for temporary protection. These fuzes should be examined carefully for serviceability.

6. For detailed information on fuzing and defuzing, refer to OP 988 (First Revision).

7. Installation of long-delay Fuzes T753 or T756 with Conical Fin Assembly M126 (T147) requires a special operation to lock each fuze in place. Refer to OP 988 (First Revision).

CAUTION: The 250-lb GP Bomb AN-M57A1, installed with Conical Fin Assembly M126 (T147), uses Tail Fuzes T753 or T756 which incorporate an anti-withdrawal device. Non-detonation of bombs fuzed with Fuze T753 or T756 when released "SAFE" cannot be relied upon, because the glass ampule in the fuze may break upon impact of the bomb. Once Fuze T753 or T756 is installed, never attempt to remove the fuze or to return the bomb to an airfield or aircraft carrier, upon an incomplete mission. Do not turn Fuze T753 or T756 back and forth to engage threads; use a "screwing-in" motion only. The anti-withdrawal device will cause the fuze and bomb to detonate if the fuze is rotated counterclockwise while in the adapter-booster, even before threads are engaged.

Section 4.6—500-lb GP Bomb AN-M64A1 with Fin Assembly AN-M109A1

Description

The 500-lb GP Bomb AN-M64A1, figure 4.10, has a cylindrical metal casing, an ogival nose, and a tapered aft end. A box-type fin assembly (AN-M109A1) is secured to the aft end of the bomb with a fin locknut.

The bomb uses both a nose and a tail fuze. Usually, both fuzes are used for the majority of bombing operations. Unlike the smaller bombs of the GP series, Bomb AN-M64A1 has an adapter-booster capable of receiving a tail fuze with a two-inch thread (such as hydrostatic Tail Fuze AN-Mk 230) instead of the 1½-inch thread capacity of the smaller GP bombs. A fuze adapter may be used on the inside of the adapter-booster to convert the seat to accommodate fuzes with the smaller 1½-inch threads.

Special studs, attached to the base plug, are imbedded in the solidified explosive filler, locking the base plug to the bomb body. The adapter-booster and fuze adapter are locked in the base plug by a locking pin that extends from the adapter-booster to a groove in the base plug.

Approximately 50 percent of the complete bomb weight is explosive filler. Double suspension lugs are welded 14 inches apart, and a single suspension lug is welded to the opposite side of the bomb body.

The bomb is painted olive-drab; yellow color bands and black-stenciled nomenclature identify the bomb and its high-explosive charge.

Differences Between Bombs AN-M64A1 and AN-M64

Bomb AN-M64A1 contains anti-withdrawal pins in the base plug, and an adapter-booster and fuze adapter that can be locked in place. The earlier Bomb AN-M64, lacks these anti-withdrawal features.

Bomb AN-M43, an earlier model of the 500-lb GP Bomb, is similar to the AN-M64, but has a base plug which will accept only fuzes with a 1½-inch diameter thread.

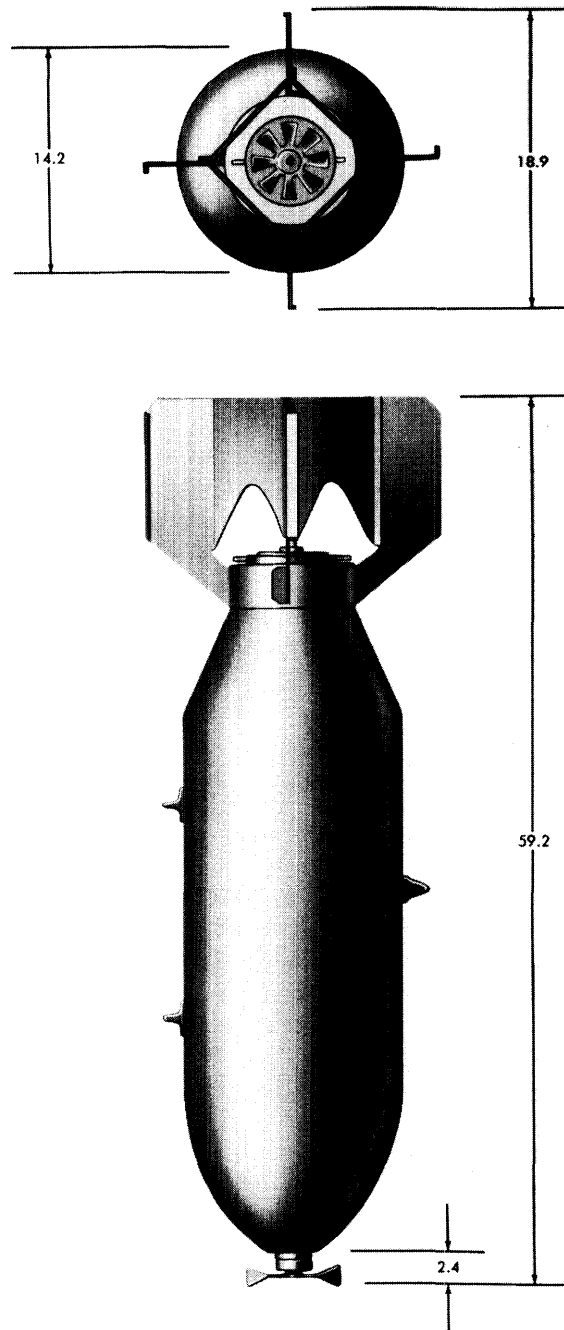

Figure 4.10—500-lb GP Bomb AN-M64A1 with Fin Assembly AN-M109A1.

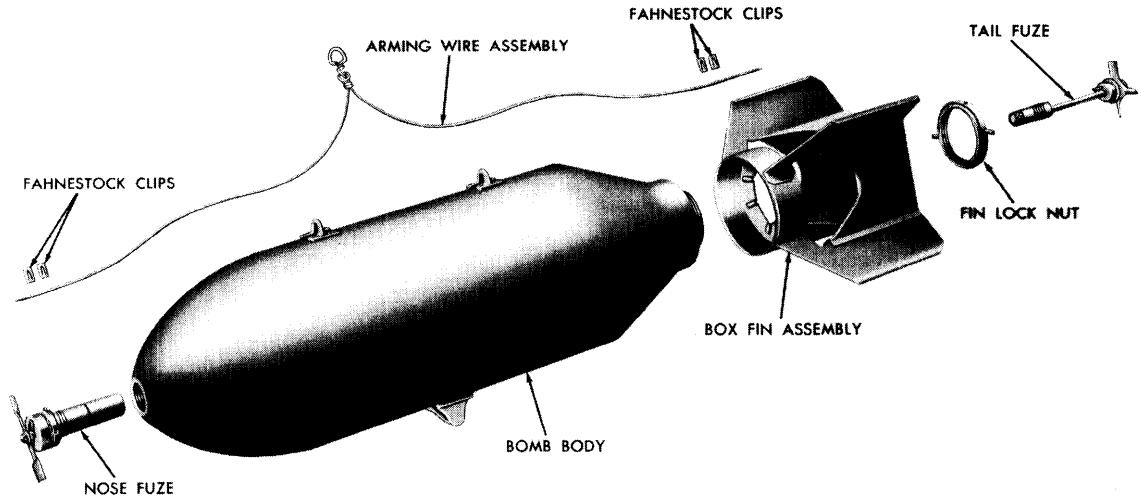

Figure 4.11—500-lb GP Bomb AN-M64A1 with Fin Assembly AN-M109A1, Exploded View.

Physical Characteristics of GP Bomb AN-M64A1 with Fin Assembly AN-M109A1

Weight of assembled fuzed bomb:	
Loaded with TNT	545.7 lbs
Loaded with Tritonal	564.7 lbs
Weight of explosive:	
TNT	264.0 lbs
Tritonal	283.0 lbs
Weight of fin:	
Fin Assembly AN-M109A1	18.6 lbs
Dimensions:	
Length of complete bomb	59.16 inches
Length of bomb body	44.9 inches
Diameter	14.18 inches
Fin span	18.94 inches
Fin length	13.9 inches
Suspension:	
Two suspension lugs	14 inches c to c
Single suspension lug	Center of gravity

Components of a Complete Round (Figures 4.11 and 4.12)

- Bomb body assembly (including):
- Bomb body
- Fin locknut (or Fin Lock Nut M2)
- Closing plugs

Fin Assembly AN-M109A1

Nose fuze (one of):

- AN-M103A1
- AN-M139A1
- AN-M140A1
- Mk 243 Mod 0
- Mk 244 Mod 1
- VT Fuze AN-M166
- VT Fuze AN-M168

Tail fuze (one of):

- AN-M101A2
- AN-Mk 230
- M116
- M124A1
- M133

- Arming wire assembly
- Fahnestock clips

Assembly

CAUTION: Fuzes and bombs shall not be unpacked in advance of requirements and shall be returned to their original packings, if not used.

1. Remove shipping bands from bombs by removing nuts from securing bolts. Remove closing plugs.

CAUTION: Inspect for damage (cracks, broken weldments, etc.) which might weaken lugs or their attachment to the bomb body.

2. Cut the shipping wire, and remove fin locknut and its protector. Remove protector from locknut.

3. Remove fin assembly and attachments from shipping crate. Position fins to clear aircraft structure and ground, when installed. Replace fin locknut and tighten with wrench. When bomb is to be carried externally at speeds in excess of 350 knots, Fin Lock Nut M2 should be used in place of the regular fin locknut. Setscrews should be tightened securely. This is necessary to prevent rotation of the fin assembly. (Refer to NAVORD Instruction 8150.1).

CAUTION: Do not use fin assembly if it cannot be secured to the bomb properly. If the fin assembly is loose and turns on the bomb, it will pull the arming wire from the tail fuze, causing it to arm prematurely.

4. Install bomb on aircraft and securely lock in place. If bomb bay does not provide enough space for fuzing, fuzing shall be done prior to hoisting bomb into place on the rack.

5. Remove required number of fuzes and arming wire assemblies from their containers.

CAUTION: If containers are punctured, split, or if the seal is broken in

any way, the fuzes contained therein shall be considered unserviceable. This does not apply to fuzes repacked in the field and resealed with adhesive tape for temporary protection. These fuzes should be examined carefully for serviceability.

6. For detailed information on fuzing and defuzing, refer to OP 988 (First Revision).

CAUTION: The 500-lb GP Bomb AN-M64A1 uses Tail Fuzes M124A1 or M133 which incorporate an anti-withdrawal device. Non-detonation of bombs fuzed with Fuze M124A1 or M133 when released "SAFE" cannot be relied upon, because the glass ampule in the fuze may break upon impact of the bomb. Once Fuze M124A1 or M133 is installed, never attempt to remove the fuze from the bomb. Do not turn Fuze M124A1 or M133 back and forth to engage threads. Use a "screwing-in" motion only. The anti-withdrawal device will cause the fuze and bomb to detonate if the fuze is rotated counterclockwise while in the adapter-booster, even before threads are engaged.

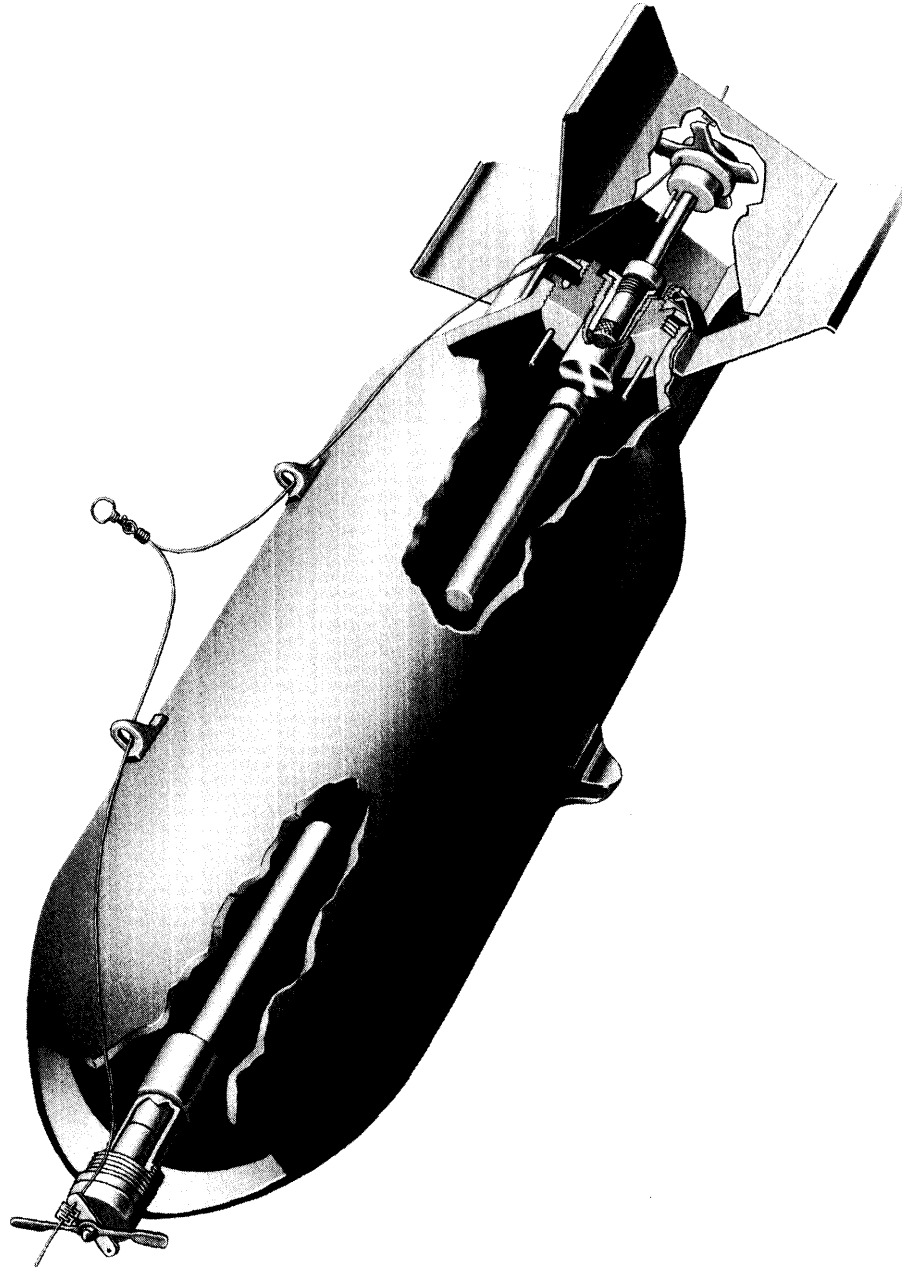

Figure 4.12—500-lb GP Bomb AN-M64A1 with Fin Assembly AN-M109A1, Cutaway View.

Section 4.7—500-lb GP Bomb AN-M64A1 with Fin Assembly M28A1 (T127)

Description

The 500-lb GP Bomb AN-M64A1 equipped with Fin Assembly M128A1 (T127) uses the standard Bomb Body AN-M64A1. The elongated cone of the assembled fin lengthens and streamlines the bomb. This increases its aerodynamic performance and accuracy in bombing. Conical Fin Assembly M128A1 consists of an elongated cone with four integral fins spaced at equal distances on the cone. A support tube runs through the center of the cone, and the fin assembly is secured to the bomb body by means of this support tube, a locking web, and a locknut. When Bomb AN-M64A1 is installed with a conical fin assembly, the new long-stem tail fuzes are required so that the arming vane is located effectively in the airstream.

Physical Characteristics of GP Bomb AN-M64A1 with Fin Assembly M128A1

Weight of assembled fuzed bomb:
 Loaded with TNT 566.8 lbs
 Loaded with Tritonal 585.8 lbs
 Weight of explosive:
 TNT 264.0 lbs
 Tritonal 283.0 lbs

Weight of fin:
 Fin Assembly M128A1- 41.0 lbs
 (T127)
 Dimensions:
 Length of complete bomb 72.1 inches
 Length of bomb body . . . 44.9 inches
 Diameter 14.18 inches
 Fin span 19.56 inches
 Fin length 32.7 inches
 Suspension:
 Two suspension lugs . . . 14 inches c to c
 Single suspension lug . . Center of gravity

Components of a Complete Round (Figure 4.13)

Bomb body assembly (including):
 Bomb body
 Fin locknut (Supplied with bomb body; to be removed and discarded)
 Closing plugs
 Fin Assembly M128A1 (T127)
 Fin Lock Nut (Dwg 1350522)
 Fin Locking Web (BuOrd Sk 329153) } supplied separately.

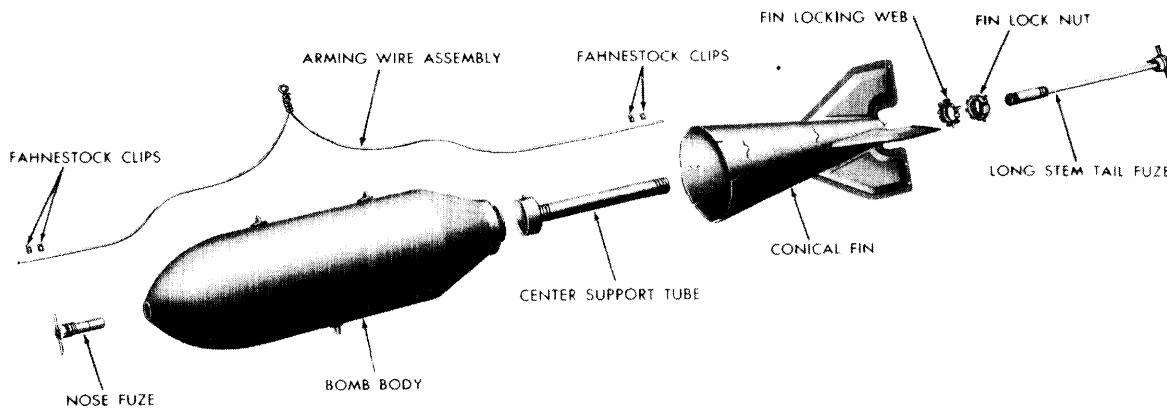

Figure 4.13—500-lb GP Bomb AN-M64A1 with Fin Assembly M128A1, Exploded View.

Nose fuze (one of):

AN-M103A1
 AN-M139A1
 AN-M140A1
 Mk 243 Mod 0
 Mk 244 Mod 1
 VT Fuze AN-M166
 VT Fuze AN-M168

Tail fuze (one of):

M175
 M181 (T781)
 T753
 T756

Arming Wire Assembly Mk 1, AN-M6A2, or
 M16

Fahnestock clips

Assembly

CAUTION: Fuzes and bombs shall not be unpacked in advance of requirements. Return them to their original packings, if not used.

1. Remove shipping bands from bomb by removing nuts from securing bolts. Remove closing plugs.

CAUTION: Inspect for damage (cracks, broken weldments, etc.) which might weaken lugs or their attachment to the bomb body.

2. Cut the shipping wire. Remove fin locknut and discard it with its protector.

3. Remove fin assembly and attachments from shipping crate. Thread center support tube onto base plug of bomb (locknut seat). Tighten tube with wrench. Tighten setscrews in support tube. Place fin cone over support tube. Slide cone back until jammed against bomb body. Position fins to clear aircraft structure and ground, when installed. Place fin locking web over support tube so that it engages fins of fin assembly. Secure conical fin assembly to support tube by threading on special locknut. (Discard locknut supplied with fin assembly). Tighten locknut with

special notched wrench. Bend two tabs of locking web into locknut slots. Secure nut in position by means of setscrews.

4. Install bomb on aircraft and securely lock in place. If bomb bay does not provide enough space for fuzing, fuzing shall be done prior to hoisting bomb into place on the rack.

5. Remove required number of fuzes and arming wire assemblies from their containers.

CAUTION: If containers are punctured, split, or if the seal is broken in any way, the fuzes contained therein shall be considered unserviceable. This does not apply to fuzes repacked in the field and resealed with adhesive tape for temporary protection. These fuzes should be examined carefully for serviceability.

6. For detailed information on fuzing and defuzing, refer to OP 988 (First Revision).

7. Installation of Conical Fin Assembly M128A1 (T127) necessitates the use of a special tail fuzing operation entailing the use of an arming stem tube. Refer to OP 988 (First Revision).

CAUTION: Bomb AN-M64A1, installed with Conical Fin Assembly M128A1 (T127), uses Tail Fuzes T753 or T756 which incorporate an anti-withdrawal device. Non-detonation of bombs fuzed with Fuze T753 or T756 when released "SAFE" cannot be relied upon, because the glass ampule in the fuze may break upon impact of the bomb. Once Fuze T753 or T756 is installed, never attempt to remove the fuze. Do not turn Fuze T753 or T756 back and forth to engage threads. Use a "screwing-in" motion only. The anti-withdrawal device will cause the fuze and bomb to detonate if the fuze is rotated counterclockwise while in the adapter-booster, even before threads are engaged.

Section 4.8—1000-lb GP Bomb AN-M65A1 with Fin Assembly AN-M113A1

Description

The 1000-lb GP Bomb AN-M65A1, figure 4.14, has a cylindrical metal casing, an ogival nose, and a tapered aft end. A box-type fin assembly (AN-M113A1) is secured to the aft end of the bomb with a fin locknut.

The bomb uses both a nose and a tail fuze. Usually, both fuzes are used for the majority of bombing operations. AN-M65A1 uses an adapter-booster that will accommodate tail fuzes with 2-inch diameter threads. A fuze adapter may be used on the inside of the adapter-booster to convert the seat to accommodate fuzes with the smaller 1½-inch threads.

Special studs attached to the base plug and imbedded in the solidified explosive filler prevent removal of the base plug. The adapter-booster and fuze adapter are locked to the base plug with a locking pin that extends from the adapter-booster to a groove in the base plug.

Approximately 50 percent of the complete bomb weight is explosive filler. Double suspension lugs are welded 14 inches apart, and a single suspension lug is welded to the opposite side of the bomb case. The bomb is painted olive-drab; yellow color bands and black-stenciled nomenclature identify the bomb and its high-explosive charge.

Differences Between Bombs AN-M65A1 and AN-M65

Bomb AN-M65A1 contains anti-withdrawal pins in the base plug, and an adapter-booster and fuze adapter that can be locked in place. The earlier Bomb AN-M65 lacks these anti-withdrawal features.

The released weight of AN-M65 is greater than that of AN-M65A1; AN-M65 has an explosive charge to total weight ratio of 53 percent as compared to the 50 percent ratio of Bomb AN-M65A1.

Bomb AN-M44, an earlier model of the 1000-lb GP bomb, is similar to AN-M64, but has a base plug which will accept only fuzes with a 1½-inch diameter thread.

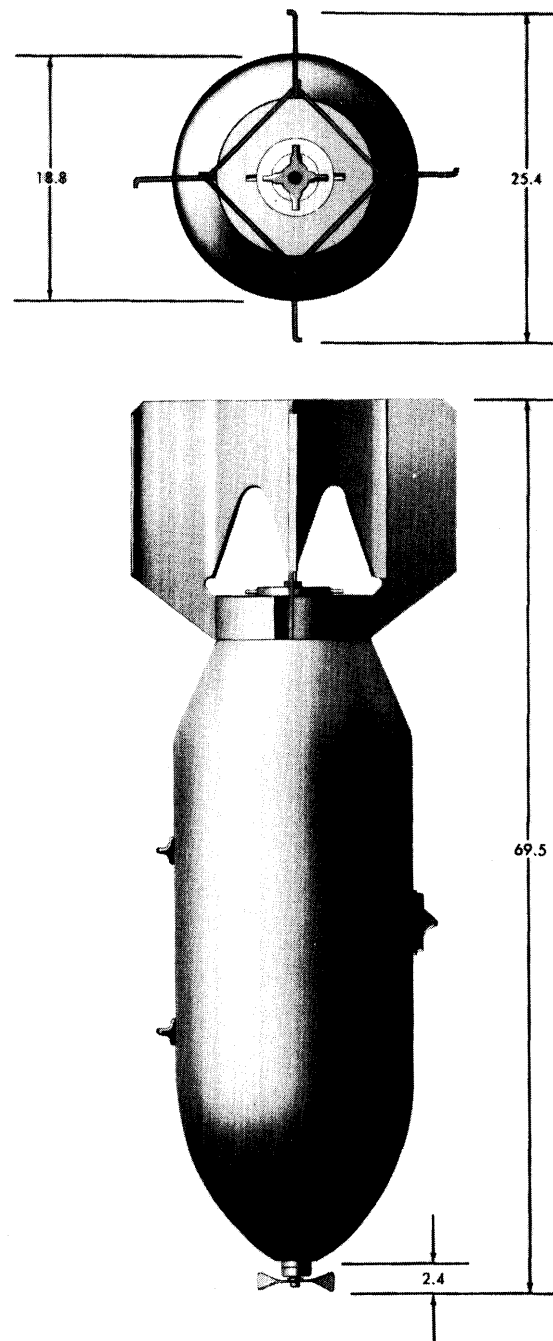

Figure 4.14—1000-lb GP Bomb AN-M65A1 with Fin Assembly AN-M113A1.

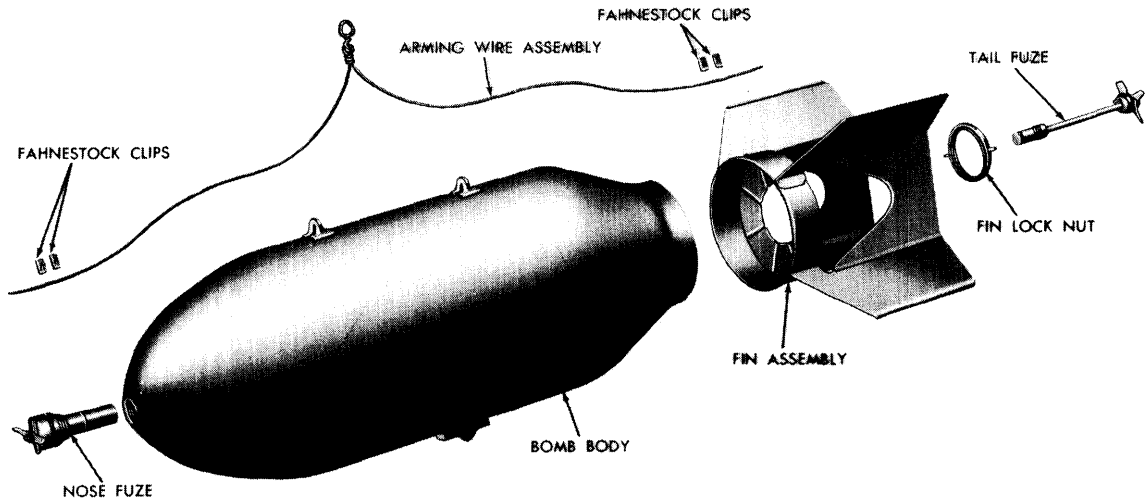

Figure 4.15—1000-lb GP Bomb AN-M65A1 with Fin Assembly AN-M113A1, Exploded View.

Physical Characteristics of GP Bomb AN-M65A1 with Fin Assembly AN-M113A1

Weight of assembled fuzeed bomb:

Loaded with TNT	1064.0 lbs
Loaded with Tritonal	1104.0 lbs

Weight of explosive:

TNT	555.0 lbs
Tritonal	595.0 lbs

Weight of fin:

Fin Assembly AN-M113A1	32.1 lbs
------------------------	----------

Dimensions:

Length of complete bomb	69.5 inches
Length of bomb body	51.0 inches
Diameter	18.8 inches
Fin span	25.4 inches
Fin length	18.52 inches

Suspension:

Two suspension lugs	14 inches c to c
Single suspension lug	Center of gravity

Fin Assembly AN-M113A1

- Nose fuze (one of):
- AN-M103A1
 - AN-M139A1
 - AN-M140A1
 - Mk 243 Mod 0
 - Mk 233 Mod 1
 - VT Fuze AN-M166
 - VT Fuze AN-M168
- Tail fuze (one of):
- AN-M102A2
 - AN-Mk 230
 - M117
 - M125A1
 - M134
- Arming wire assembly
Fahnestock clips

Assembly

CAUTION: Fuzes and bombs shall not be unpacked in advance of requirements and shall be returned to their original packings, if not used.

1. Remove shipping bands from bomb by removing nuts from securing bolts. Remove closing plugs.

CAUTION: Inspect for damage (cracks, broken weldments, etc.) which might weaken lugs or their attachment to the bomb body.

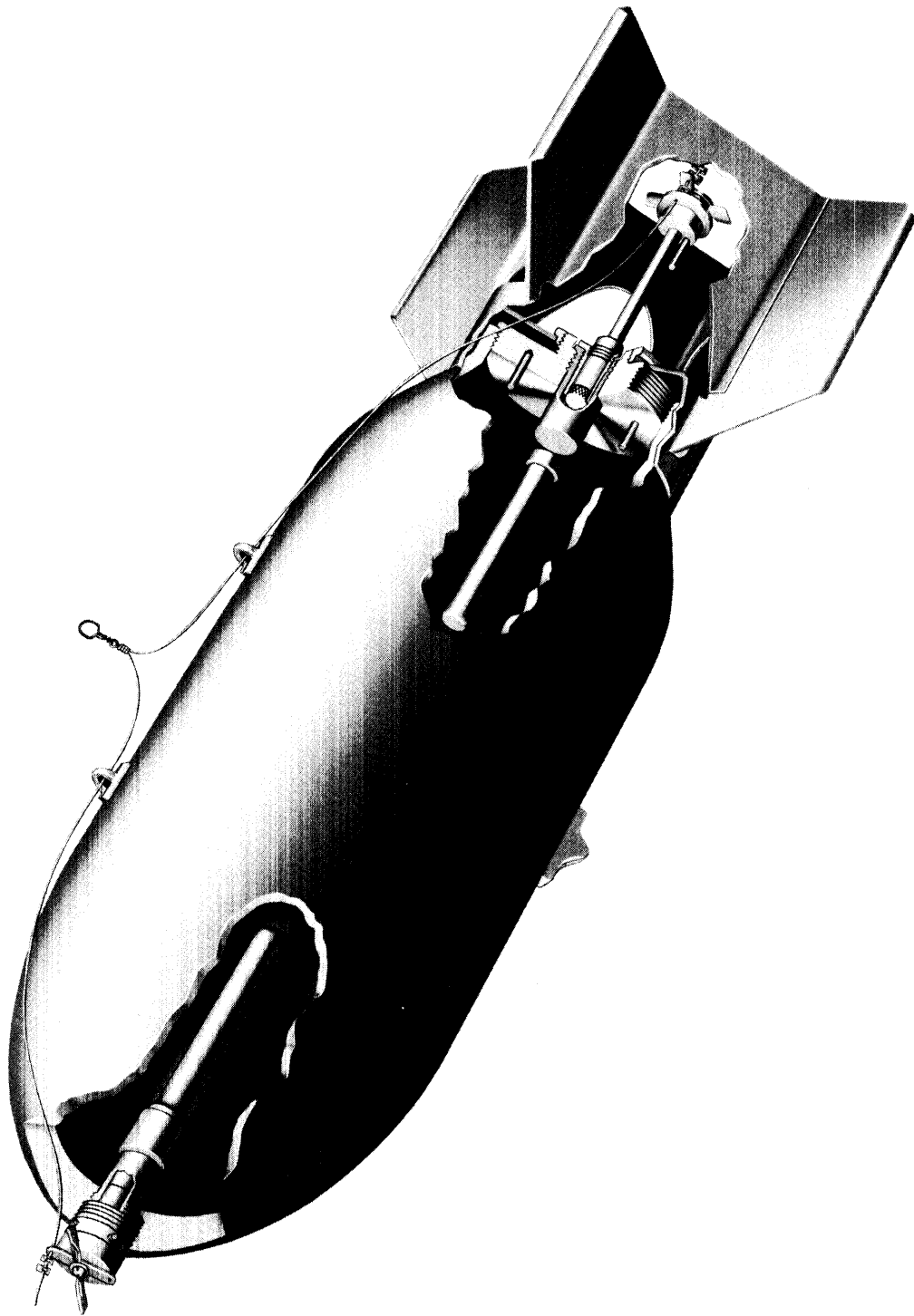

Figure 4.16—1000-lb GP Bomb AN-M65A1 with Fin Assembly AN-M113A1, Cutaway View.

2. Cut the shipping wire, and remove fin locknut and its protector. Remove protector from locknut.

3. Remove fin assembly and attachments from shipping crate. Position fins to clear aircraft structure and ground, when installed. Replace fin locknut and tighten with wrench. When bomb is to be carried externally at speeds in excess of 350 knots, Fin Lock Nut M2 should be used in place of the regular fin locknut. Setscrews should be tightened securely. This is necessary to prevent rotation of the fin assembly. (Refer to NAVORD Instruction 8150.1).

CAUTION: Do not use fin assembly if it cannot be secured to the bomb properly. If the fin assembly is loose and turns on the bomb, it will pull the arming wire from the tail fuze, causing it to arm prematurely.

4. Install bomb on aircraft and securely lock in place. If bomb bay does not provide enough space for fuzing, fuzing shall be done prior to hoisting bomb into place on the rack.

5. Remove required number of fuzes and arming wire assemblies from their containers.

CAUTION: If containers are punctured, split, or if the seal is broken in

any way, the fuzes contained therein shall be considered unserviceable. This does not apply to fuzes repacked in the field and resealed with adhesive tape for temporary protection. These fuzes should be examined carefully for serviceability.

6. For detailed information on fuzing and defuzing, refer to OP 988 (First Revision).

CAUTION: The 1000-lb GP Bomb AN-M65A1 uses Tail Fuzes M125A1 or M134 which incorporate an anti-withdrawal device. Non-detonation of bombs fuzed with Fuze M125A1 or M134 when released "SAFE" cannot be relied upon, because the glass ampule in the fuze may break upon impact of the bomb. Once Fuze M125A1 or M134 is installed, never attempt to remove the fuze from the bomb. Do not turn Fuze M125A1 or M134 back and forth to engage threads. Use a "screwing-in" motion only. The anti-withdrawal device will cause the fuze and bomb to detonate if the fuze is rotated counterclockwise while in the adapter-booster, even before threads are engaged.

Section 4.9—1000-lb GP Bomb AN-M65A1 with Fin Assembly M129 (T142)

Description

The 1000-lb GP Bomb AN-M65A1 equipped with Fin Assembly M129 (T142) uses the standard Bomb Body AN-M65A1. The elongated cone of the fin assembly lengthens and streamlines the bomb. Conical Fin Assembly M129 consists of a fin cone with four integral fins spaced at equal distances on the cone. A support tube runs through the center of the cone, and the fin assembly is secured to the bomb body by means of this support tube, a locking web, and a locknut. Conical Fin Assembly M129 was developed to increase aerodynamic performance and accuracy in bombing. When GP Bomb AN-M65A1 is installed with a conical fin assembly, the new long-stem tail fuze is required so that the arming vane can be located effectively in the airstream.

Physical Characteristics of GP Bomb AN-M65A1 with Fin Assembly M129

Weight of assembled fuzeed bomb:
 Loaded with TNT 1165.2 lbs
 Loaded with Tritonal 1205.2 lbs
 Weight of explosive:
 TNT 555.0 lbs
 Tritonal 595.0 lbs

Weight of fin:
 Fin Assembly M129 73.0 lbs
 (T142)
 Dimensions:
 Length of complete bomb 91.1 inches
 Length of bomb body . . . 51.0 inches
 Diameter 18.8 inches
 Fin span 26.2 inches
 Fin length 46.5 inches
 Suspension:
 Two suspension lugs . . . 14 inches c to c
 Single suspension lug . . . Center of gravity

Components of a Complete Round (Figure 4.17)

- Bomb body assembly (including):
 - Bomb body
 - Fin locknut (Supplied with bomb body; to be removed and discarded)
 - Closing plugs
 - Fin Assembly M129 (T142)
 - Fin Lock Nut (Dwg 1350522)
 - Fin Locking Web (BuOrd Sk 329153)
- } supplied separately.
- Nose fuzes (one of):
 - AN-M103A1
 - AN-M139A1
 - AN-M140A1

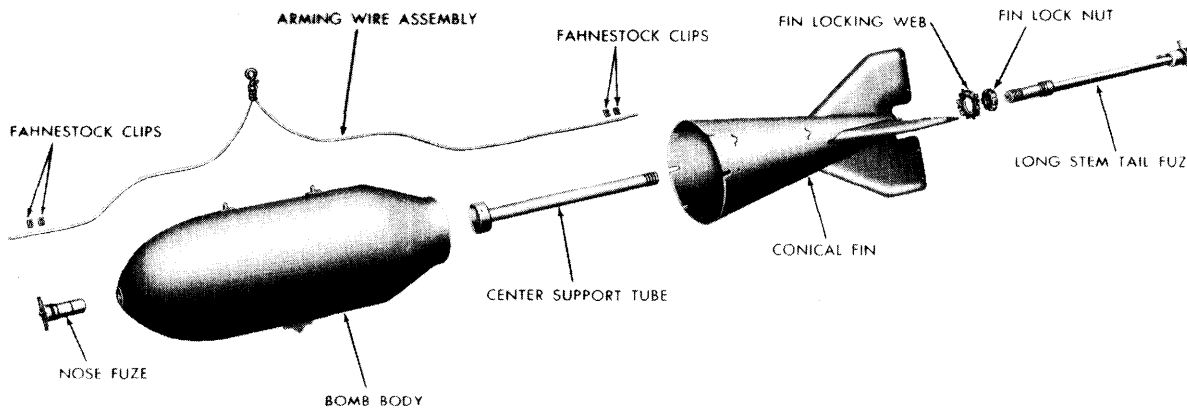

Figure 4.17—1000-lb GP Bomb AN-M65A1 with Fin Assembly M129, Exploded View.

Nose fuzes (one of)—Continued

Mk 243 Mod 0

Mk 244 Mod 1

VT Fuze AN-M166

VT Fuze AN-M168

Tail fuze (one of):

M177

M185 (T740)

T755

T758

M183 (T783)

Arming Wire Assembly Mk 1, AN-M6A2,
or M16

Fahnestock clips

Assembly

CAUTION: Fuzes and bombs shall not be unpacked in advance of requirements. Return them to their original packings, if not used.

1. Remove shipping bands from bomb by removing nuts from securing bolts. Remove closing plugs.

CAUTION: Inspect for damage (cracks, broken weldments, etc.) which might weaken lugs or their attachment to the bomb body.

2. Cut the shipping wire. Remove fin locknut and discard it with its protector.

3. Remove fin assembly and attachments from shipping crate. Thread center support tube onto base plug of bomb (locknut seat). Tighten tube with wrench. Tighten setscrews in support tube. Place fin cone over support tube. Slide cone back until jammed against bomb body. Position fins to clear aircraft structure and ground, when installed. Place fin locking web over support tube so that it engages fins of the fin assembly. Secure conical fin assembly to support tube by threading on special locknut (discard locknut supplied with

fin assembly). Tighten locknut with special notched wrench. Bend two tabs of locking web into locknut slots. Secure nut in position by means of setscrews.

4. Install bomb on aircraft and securely lock in place. If bomb bay does not provide enough space for fuzing, fuzing shall be done prior to hoisting bomb into place on the rack.

5. Remove required number of fuzes and arming wire assemblies from their containers.

CAUTION: If containers are punctured, split, or if the seal is broken in any way, the fuzes contained therein shall be considered unserviceable. This does not apply to fuzes repacked in the field and resealed with adhesive tape for temporary protection. These fuzes should be examined carefully for serviceability.

6. For detailed information on fuzing and defuzing, refer to OP 988 (First Revision).

7. Installation of long-delay Fuze T755 or T758 with Conical Fin Assembly M129 requires a special operation to lock the fuze in place. Refer to OP 988 (First Revision).

CAUTION: Bomb M65A1, installed with Conical Fin Assembly M129 (T142), uses Fuzes T755 or T758 which incorporate an anti-withdrawal device. Non-detonation of bombs fuzed with Fuze T755 or T758 when released "SAFE" cannot be relied upon, because the glass ampule in the fuze may break upon impact of the bomb. Do not turn Fuze T755 or T758 back and forth to engage threads; use a "screwing-in" motion only. The anti-withdrawal device will cause the fuze bomb to detonate if the fuze is rotated counterclockwise while in the adapter-booster, even before threads are engaged.

Section 4.10—2000-lb GP Bomb AN-M66A2 with Fin Assembly AN-M116A1

Description

The 2000-lb GP Bomb AN-M66A2, figure 4.18, has a cylindrical metal case, an ogival nose, and a tapered aft end. A box-type fin assembly (AN-M116A1) is secured to the aft end of the bomb with a fin locknut.

The bomb accommodates both a nose and a tail fuze. Both fuzes are used for the majority of bombing operations. The AN-M66A2 has an adapter-booster capable of receiving tail fuzes with a 2-inch thread diameter. A fuze adapter may be inserted into the adapter-booster to convert the seat to accommodate the smaller fuzes with 1½-inch diameter threads.

Special studs attached to the base plug and imbedded in the solidified explosive filler prevent removal of the base plug. The adapter-booster (and fuze adapter, when used) are locked to the base plug with a locking pin that extends from the adapter-booster to a groove in the base plug.

Approximately 50 percent of the complete weight of the bomb consists of explosive filler. Double suspension lugs are welded to the bomb case with 30 inches between centers. A single suspension lug is welded to the case on the opposite side at the center of gravity. The bomb is painted olive-drab; yellow color bands and black-stenciled nomenclature identify the bomb and its high-explosive charge.

Differences Between Bombs AN-M66A2, AN-M66A1, and AN-M66

Bombs AN-M66A2 and AN-M66A1 contain anti-withdrawal pins in the base plug, and an adapter-booster and fuze adapter that can be locked in place. The earlier Bomb AN-M66 lacks these features.

AN-M66A2 differs further from AN-M66A1 and AN-M66 by a thicker and rounder nose. In Bomb AN-M66A2, the ratio of explosive charge to total weight is approximately 50 percent as compared to an average weight-ratio of 53 percent in the other two bombs.

Bomb AN-M34, an earlier model of the 2000-lb GP bomb, is similar to AN-M66, but has a base plug which will accept only fuzes with a 1½-inch diameter thread.

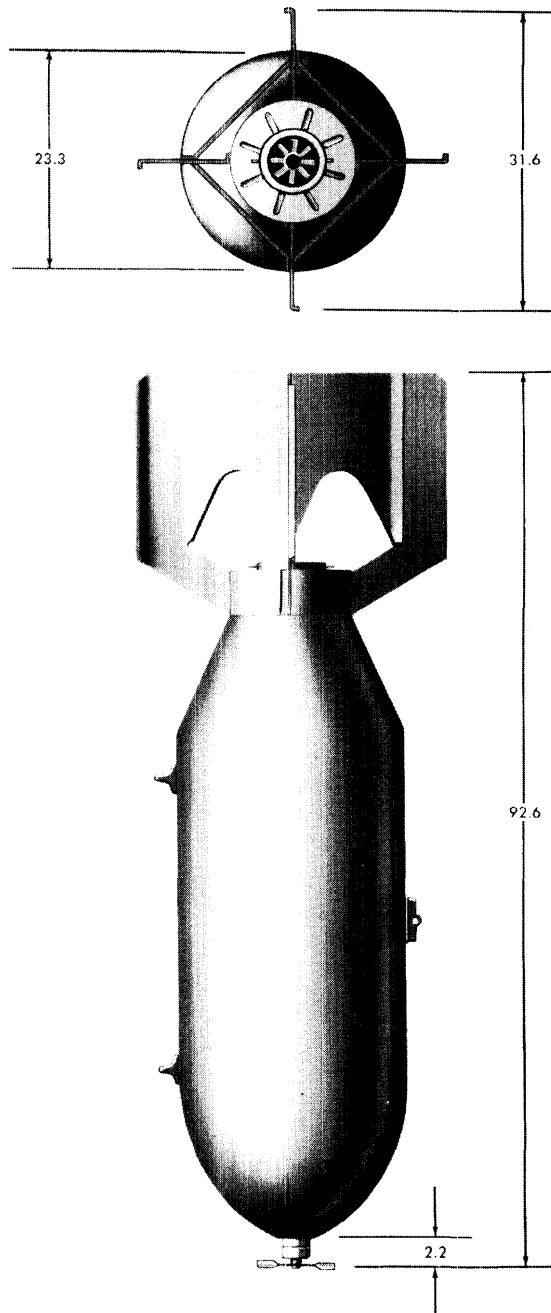

Figure 4.18—2000-lb GP Bomb AN-M66A2 with Fin Assembly AN-M116A1.

Physical Characteristics of GP Bomb AN-M66A2 with Fin Assembly AN-M116A1

- Weight of assembled fuzeed bomb:
 - Loaded with TNT..... 2118.5 lbs
 - Loaded with Tritonal 2196.5 lbs
- Weight of explosive:
 - TNT..... 1097.8 lbs
 - Tritonal..... 1181.0 lbs
- Weight of fin:
 - Fin Assembly AN-M116A1 54.4 lbs
- Dimensions:
 - Length of complete bomb 92.63 inches
 - Length of bomb body 67.8 inches
 - Diameter..... 23.29 inches
 - Fin span..... 31.6 inches
 - Fin length..... 25.0 inches
- Suspension:
 - Two suspension lugs... 30 inches c to c
 - Single suspension lug.. Center of gravity

- Fin Assembly AN-M116A1
- Nose fuze (one of):
 - AN-M103A1
 - AN-M139A1
 - AN-M140A1
 - Mk 243 Mod 0
 - Mk 244 Mod 1
 - VT Fuze AN-M166
 - VT Fuze AN-M168
- Tail fuze (one of):
 - AN-M102A2
 - AN-Mk 230
 - M117
 - M125A1
 - M134
- Arming wire assembly
- Fahnestock clips

Components of a Complete Round (Figures 4.19 and 4.20)

- Bomb body assembly (including):
 - Bomb body
 - Fin locknut (or Fin Lock Nut M3)
 - Closing plugs

Assembly

- CAUTION:** Fuzes and bombs shall not be unpacked in advance of requirements. Return them to their original packings, if not used.
1. Remove shipping bands from bomb by removing nuts from securing bolts. Remove closing plugs.
- CAUTION:** Inspect for damage (cracks, broken weldments, etc.) which might weaken lugs or their attachment to the bomb body.

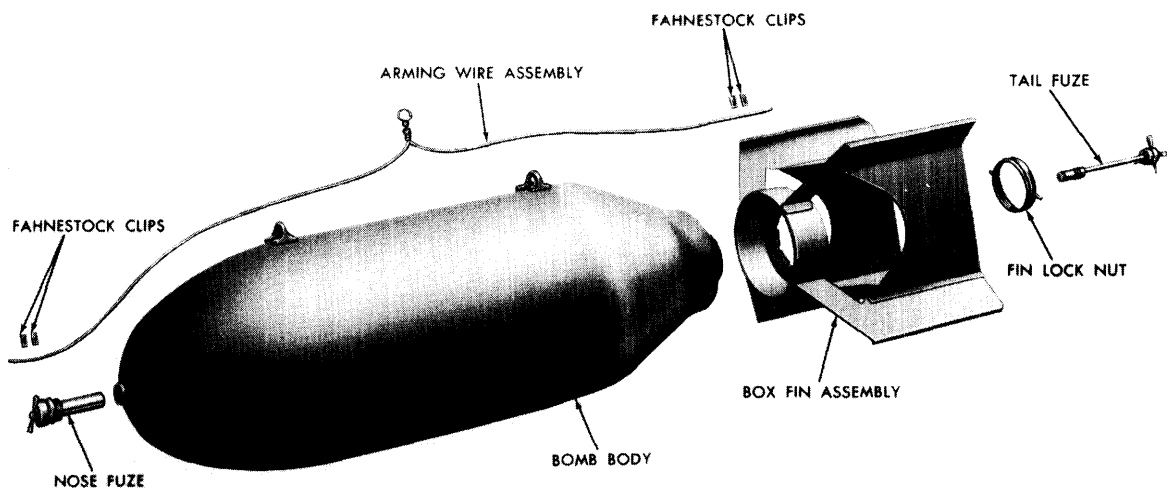

Figure 4.19—2000-lb GP Bomb AN-M66A2 with Fin Assembly AN-M116A1, Exploded View.

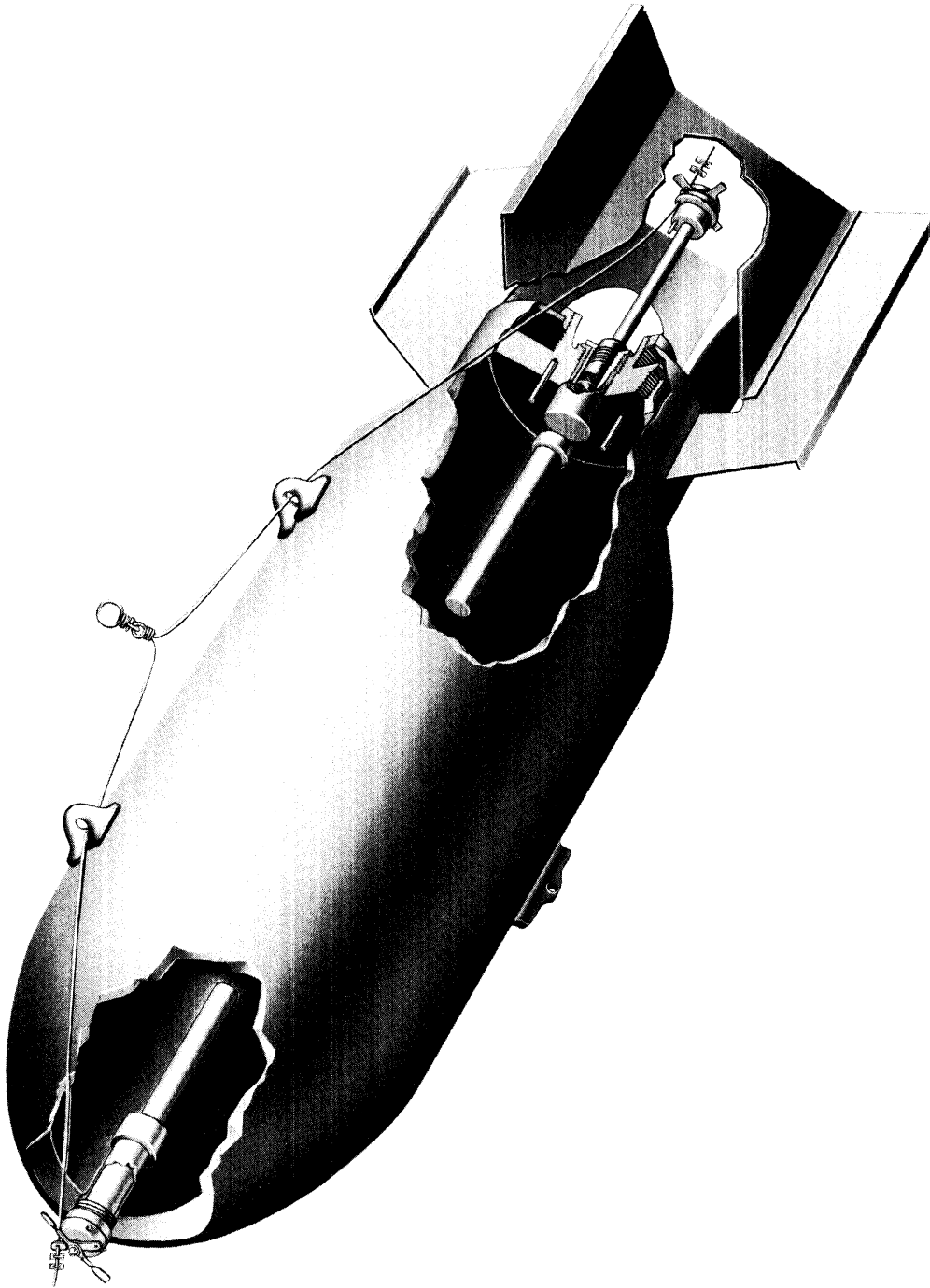

Figure 4.20—2000-lb GP Bomb AN-M66A2 with Fin Assembly AN-M116A1, Cutaway View.

2. Cut the shipping wire, and remove fin locknut and its protector. Remove protector from locknut.

3. Remove fin assembly and attachments from shipping crate. Position fins to clear aircraft structure and ground, when installed. Replace fin locknut and tighten with wrench. When bomb is to be carried externally at speeds in excess of 350 knots, Fin Lock Nut M3 should be used in place of the regular fin locknut. Setscrews should be tightened securely. This is necessary to prevent rotation of the fin assembly. Refer to NAVORD Instruction 8150.1.

CAUTION: Do not use fin assembly if it cannot be secured to the bomb properly. If the fin assembly is loose and turns on the bomb, it will pull the arming wire from the tail fuze, causing it to arm prematurely.

4. Install bomb on aircraft and securely lock in place. If bomb bay does not provide enough space for fuzing, fuzing shall be done prior to hoisting bomb into place on the rack.

5. Remove required number of fuzes and arming wire assemblies from their containers.

CAUTION: If containers are punctured, split, or if the seal is broken in

any way, the fuzes contained therein shall be considered unserviceable. This does not apply to fuzes repacked in the field and resealed with adhesive tape for temporary protection. These fuzes should be examined carefully for serviceability.

6. For detailed information of fuzing and defuzing, refer to OP 988 (First Revision).

CAUTION: The 2000-lb GP Bomb AN-M66A2 uses Tail Fuzes M125A1 or M134 which incorporate an anti-withdrawal device. Non-detonation of bombs fuzed with Fuze M125A1 or M134 when released "SAFE" cannot be relied upon, because the glass ampule in the fuze may break upon impact of the bomb. Once Fuze M125A1 or M134 is installed, never attempt to remove the fuze from the bomb. Do not turn Fuze M125A1 or M134 back and forth to engage threads; use a "screwing-in" motion only. The anti-withdrawal device will cause the fuze and bomb to detonate if the fuze is rotated counter-clockwise while in the adapter-booster, even before threads are engaged.

Section 4.11—2000-lb GP Bomb AN-M66A2 with Fin Assembly M130 (T143)

Description

The 2000-lb GP Bomb AN-M66A2 equipped with Fin Assembly M130 (T143) uses the standard Bomb Body AN-M66A2.

The elongated fin assembly lengthens and streamlines the 2000-lb GP bomb, improving its aerodynamic performance and accuracy in bombing. When Bomb AN-M66A2 is installed with a conical fin assembly, the new long-stem tail fuze is required so that the arming vane can be located effectively in the airstream.

Physical Characteristics of GP Bomb AN-M66A2 with Fin Assembly M130

- Weight of assembled fuzeed bomb:
 - Loaded with TNT..... 2194.5 lbs
 - Loaded with Tritonal... 2277.5 lbs
- Weight of explosive:
 - TNT..... 1097.8 lbs
 - Tritonal..... 1181.0 lbs
- Weight of fin:
 - Fin Assembly M130... 135.0 lbs
- Dimensions:
 - Length of complete bomb 116.8 inches
 - Length of bomb body... 67.8 inches

Dimensions—Continued

- Diameter..... 23.29 inches
- Fin span..... 32.3 inches
- Fin length..... 59.8 inches

Suspension:

- Two suspension lugs... 30 inches c to c
- Single suspension..... Center of gravity

Components of a Complete Round (Figure 4.21)

Bomb body assembly (including):

- Bomb body
- Fin locknut (Supplied with bomb body; to be removed and discarded)
- Closing plugs

Fin Assembly M130

- Fin Lock Nut (Dwg 1350522)
- Fin Locking Web (BuOrd Sk 329153) } supplied separately.

Nose fuze (one of):

- AN-M103A1
- AN-M139A1
- AN-M140A1
- Mk 243 Mod 0
- Mk 244 Mod 1
- VT Fuze AN-M166
- VT Fuze AN-M168

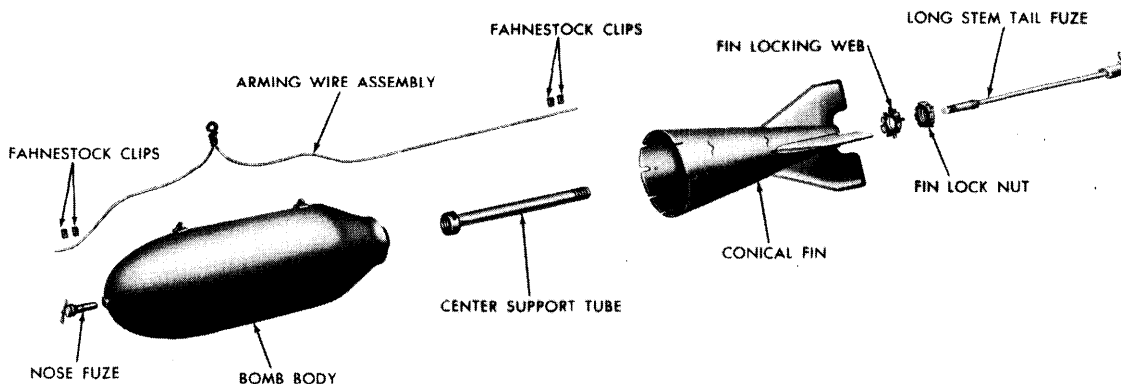

Figure 4.21—2000-lb GP Bomb AN-M66A2 with Fin Assembly M130, Exploded View.

Tail fuze (one of):

M177

M185 (T740)

T755

T758

M183 (T783)

Arming wire assembly

Fahnestock clips

Assembly

CAUTION: Fuzes and bombs shall not be unpacked in advance of requirements. Return them to their original packings, if not used.

1. Remove shipping bands from bomb by removing nuts from securing bolts. Remove closing plugs.

CAUTION: Inspect for damage (cracks, broken weldments, etc.) which might weaken lugs or their attachment to the bomb body.

2. Cut the shipping wire. Remove fin locknut and discard it with its protector.

3. Remove fin assembly and attachments from shipping crate. Thread center support tube onto base plug of bomb (locknut seat). Tighten tube with wrench. Tighten setscrews in support tube. Place fin cone over support tube. Slide cone back until jammed against bomb body. Position fins to clear aircraft structure and ground, when installed. Place fin locking web over support tube so that it engages fins of fin assembly. Secure conical fin assembly to support tube by threading on special locknut. (Discard locknut supplied with fin assembly). Tighten locknut with special notched wrench. Bend two tabs of locking web into locknut slots. Secure nut in position by means of setscrews.

4. Install bomb on aircraft and securely lock in place. If bomb bay does not provide enough space for fuzeing, fuzeing shall be done prior to hoisting bomb into place on the rack.

5. Remove required number of fuzes and arming wire assemblies from their containers.

CAUTION: If containers are punctured, split, or if the seal is broken in any way, the fuzes contained therein shall be considered unserviceable. This does not apply to fuzes repacked in the field and resealed with adhesive tape for temporary protection. These fuzes should be examined carefully for serviceability.

6. For detailed information of fuzeing and defuizing, refer to OP 988 (First Revision). Installation of long-delay Fuze T755 or T758 with Conical Fin Assembly M130 requires a special operation to lock the fuze in place. Refer to OP 988 (First Revision).

CAUTION: Bomb AN-M66A2, installed with Fin Assembly M130, uses Fuzes T755 or T758 which incorporate an anti-withdrawal device. Non-detonation of bombs fuzed with Fuze T755 or T758 when released "SAFE" cannot be relied upon, because the glass ampule in the fuze may break upon impact of the bomb. Do not turn Fuze T755 or T758 back and forth to engage threads; use a "screwing-in" motion only. The anti-withdrawal device will cause the fuze and bomb to detonate if the fuze is rotated counterclockwise while in the adapter-booster, even before threads are engaged.

Chapter 5

GENERAL PURPOSE BOMBS (LOW DRAG)

Section 5.1—General

Section 5.2—250-lb GP Bomb Mk 81 Mod 1

Section 5.3—500-lb GP Bomb Mk 82 Mods 0 and 1

Section 5.4—1000-lb GP Bomb Mk 83 Mods 2 and 3

Section 5.5—2000-lb GP Bomb Mk 84 Mod 1

Chapter 5

GENERAL PURPOSE BOMBS (LOW DRAG)

Section 5.1—General

Description

Low-drag general purpose bombs, figure 5.1, have slender bodies with long, pointed noses. Conical-type fin assemblies increase their aerodynamic performance and accuracy in bombing. The low-drag GP bombs have thicker side walls and nose sections than standard GP bombs.

These bombs have been designed primarily for electric fuzing, figure 5.1a. In line with the conventional practice for general purpose bombs, both nose and tail fuze cavities are provided. Pending the availability of electric fuzing, adapter-boosters will be furnished to permit the use of mechanical fuzes, figure 5.1b.

Low-drag GP bombs are equipped with a steel nose plug. This plug is replaced after the electric fuze is installed in the nose cavity. When mechanical or VT fuzes are used, the nose plug is not required. Instructions for disposition of unused nose plugs will be issued by the Bureau of Ordnance.

The fin assemblies have covered hand-holes for access to fuze tail positions. The base fuze-hole shipping plug is replaced after the electric fuzes are installed. This shipping plug is not required for mechanical fuzing. Instructions for disposition of unused base fuze-hole shipping plugs will be issued by the Bureau of Ordnance. When long-stem mechanical tail fuzes are installed through the after end of the fin assembly, apply torque at the fuze body by hand through the access hole and screw fuzes into place. Do not install fuzes by turning at the vane cup.

Adapter-boosters must be installed for mechanical fuzing. The nose and tail fuze cavities are connected to the outer surface of the bomb by two metal conduits which contain the electric fuze cable harness.

The explosive filler used in low-drag GP bombs is Tritonal. This explosive gives a blast effect which is greater than TNT or Composition B.

Usage

The charge-weight ratio of low-drag GP bombs makes them suitable for most bombing situations. This type of bomb can be used against moderately reinforced concrete and armor, for blast effect and for fragmentation.

Low-drag GP Bombs

- 250-lb GP Bomb Mk 81 Mod 1
- 500-lb GP Bomb Mk 82 Mods 0 and 1
- 1000-lb GP Bomb Mk 83 Mod 2
- 2000-lb GP Bomb Mk 84 Mod 1

Fuzes Compatible with Low-drag GP Bombs

Low-drag GP bombs use mechanical or electric fuzes. A combination of the following nose and tail fuzes are used with low-drag GP bombs:

Nose fuzes:

- AN-M103A1
- AN-M139A1
- AN-M140A1
- VT Fuze T750
- VT Fuze AN-M166
- M990 (T905) (electric)

Tail fuzes:

- M185 (T740)
- M190 (T759)
- M194 (T791)
- M195 (T792)
- M990 (T905) (electric)

Adapter-boosters for mechanical fuzing:

- T45E1 (nose)
- T46E4 (tail)

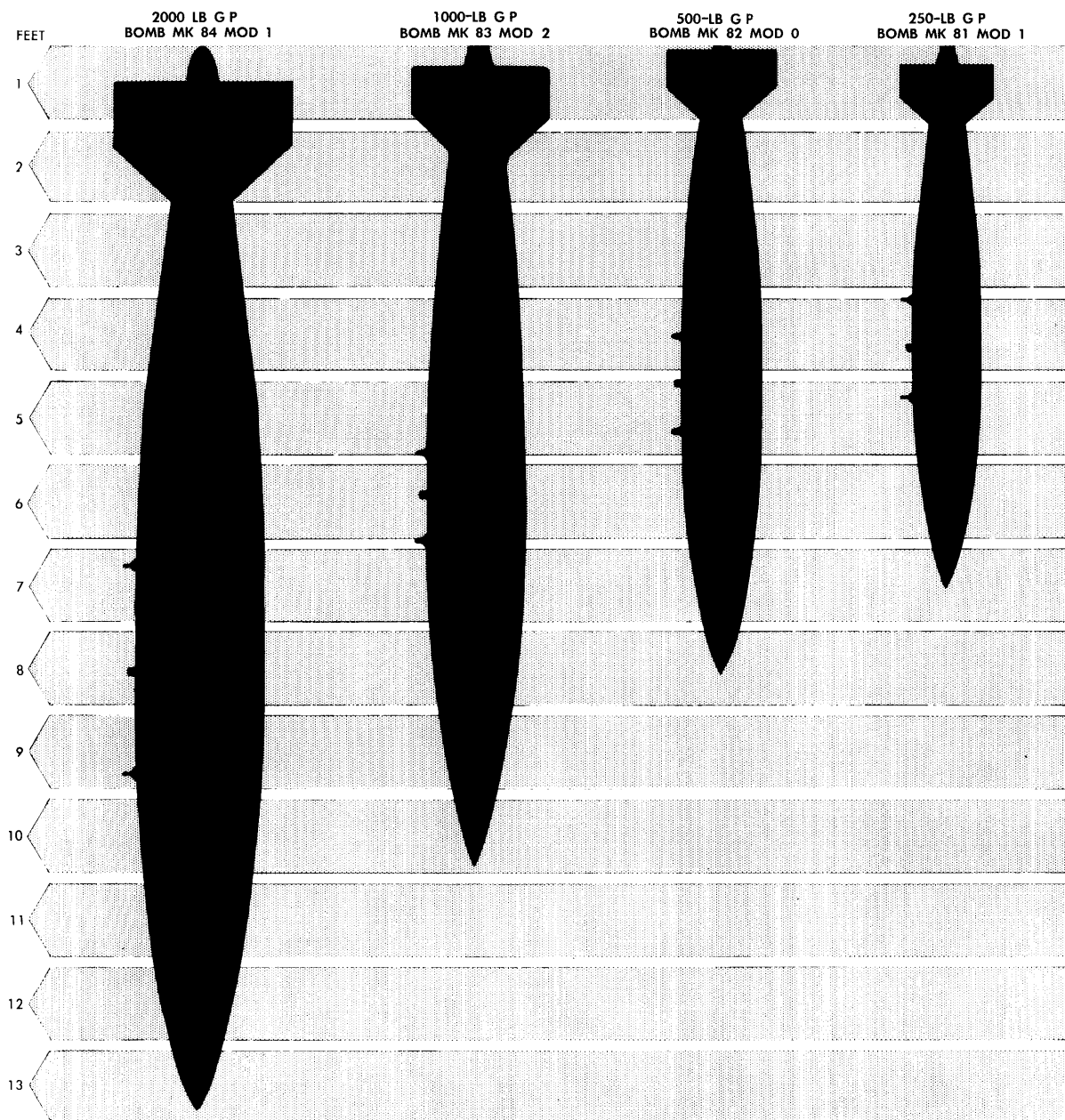

Figure 5.1a—Low-drag General Purpose Bombs (Electrically Fuzed), Comparative Size.

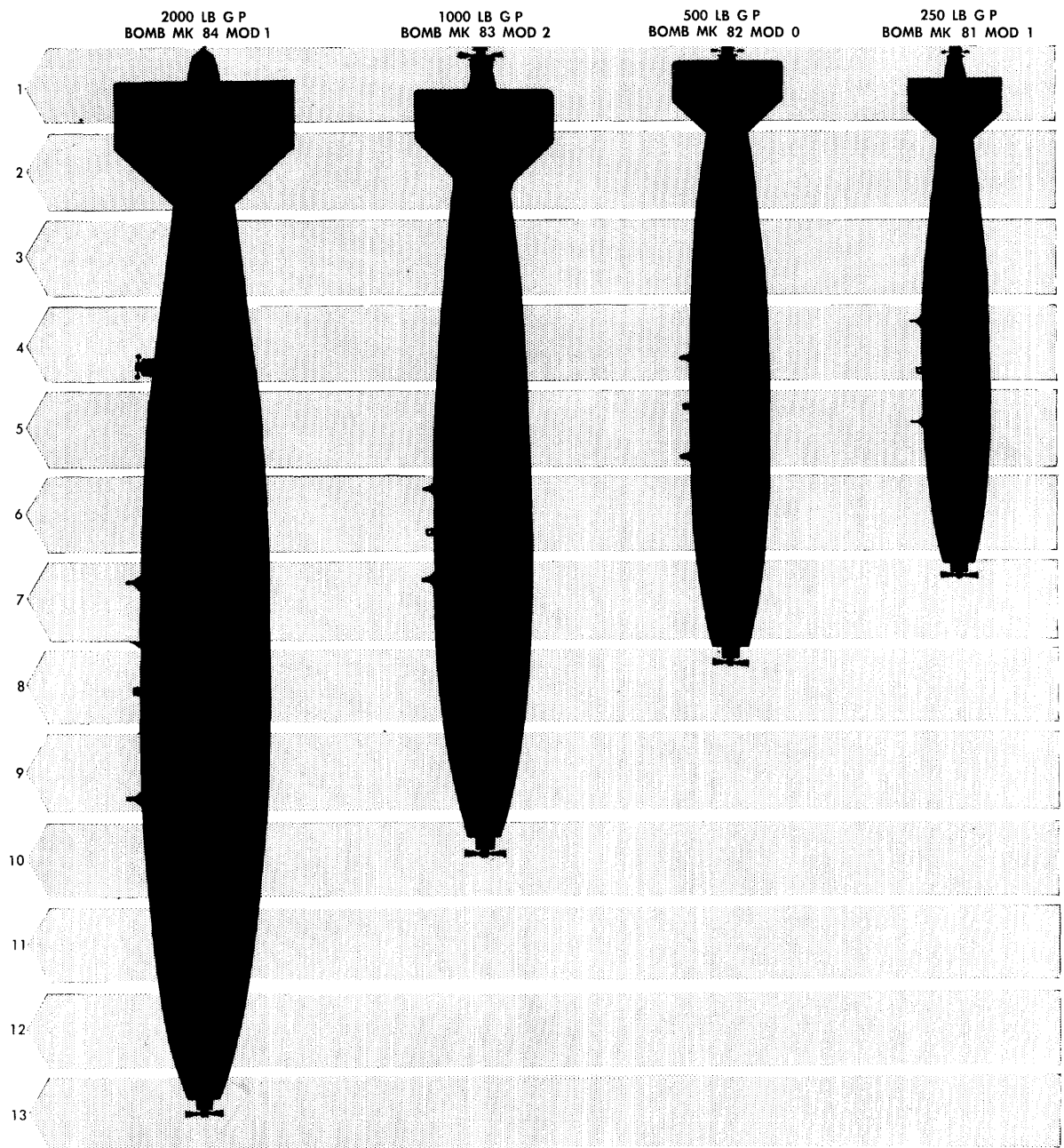

Figure 5.1b—Low-drag General Purpose Bombs (Mechanically Fuzed), Comparative Size.

Markings

Low-drag GP bombs are identified by standard nomenclature which is stenciled in yellow on the bomb body and bomb components. The complete bomb is olive drab in color. The following identifying information usually is included:

Type
Weight
Model
Ammunition lot number

Suspension

Two suspension lugs are threaded into lug inserts which are welded to the bomb body. Lugs are spaced 14 inches apart for the 250- to 1000-pound sizes. Suspension lugs are spaced 30 inches apart for the 2000-pound size. A hoisting lug located at the center of gravity is threaded into a lug insert between the two suspension lugs.

Safety Precautions

Low-drag GP bombs and their components are shipped separately and are assembled in the field to form a complete round. This permits safer handling of the bomb and its components, and reduces the probability of installing defective parts. The electric fuze cable harness, when available, will be installed in bombs by the loading activity. Bombs loaded before the fuze harness is available will be equipped with this component by ammunition depots.

Preparing low-drag GP bombs for flight requires extreme care, because a mis-step may prove fatal. Be absolutely sure of the assembly

procedure before handling the bomb or its components.

Safety Precautions To Be Observed

1. Fuzes and bombs shall not be unpacked in advance of requirements. If unpacked and not used, return them to their original packings.

2. Any accidentally armed fuze, either partially or fully armed, must be handled only by authorized personnel.

3. Fuzes shall not be assembled to bombs in anticipation of future needs.

4. Guard fuzes against dropping or bumping at all times, to prevent premature detonation.

5. Never allow primer detonators to drop or strike an object; detonators are extremely sensitive and rough handling will explode them.

6. Screw fuze into bomb handtight only; never use a tool for this operation, unless it specifically is authorized.

7. Handle and install arming vanes with care to prevent distortion of blades, and possible malfunction of both fuze and bomb.

8. Do not remove warning tags when fuze is installed in a bomb.

9. Never remove safety cotter pins or car seals from fuzes prematurely.

10. Be careful when unpacking and installing long-stem tail fuzes; do not lose any parts.

11. Replace all safety cotter pins when defuzing a bomb.

12. Do not use a fin assembly if it cannot be secured to the bomb properly, or if it is damaged.

13. Inspect arming wires for kinks, twists, and burrs. Such defects may cause a bomb to malfunction.

Section 5.2—250-lb GP Bomb Mk 81 Mod 1

Description

The 250-lb GP Bomb Mk 81 Mod 1, figure 5.2, has a slender body with a long, pointed nose. A conical-type fin is attached to the aft end of the bomb by eight setscrews.

Bomb Mk 81 Mod 1 uses either mechanical or electric fuzes. Mechanical fuzeing requires the installation of adapter-boosters. Two conduits for the electric fuze cable harness connect the nose and tail fuze cavities with the charging receptacle cavity between the lugs on the outer surface of the bomb case. When electric fuzes are not used, a plug is threaded into the charging receptacle cavity.

When fuzes are not installed, the bomb body has a nose fuze-hole plug, base fuze-hole plug, and support cup in the nose fuze cavity. When the bomb is fuzeed mechanically, these three parts are removed and the adapter-boosters and fuzes are inserted. The nose fuze-hole plug and base fuze-hole plug are replaced after electric fuzes have been installed. Adapter-boosters are not used with electric fuzes. If the bomb is tail-fuzed only, the support cup must be used in the nose cavity to prevent collapse of the fuze cavity upon heavy impact.

The bomb body has a base plug containing locking pins which are imbedded in the solidified explosive filler. Two suspension lugs, spaced 14 inches apart, and a hoisting lug at the center of gravity are threaded into lug inserts on the bomb body. The high-explosive filler, Tritonal, is identified by yellow-stenciled nomenclature on the bomb body. The base color of the bomb is olive drab.

Differences Between Certain Lots

Bombs and fin assemblies through A. O. Smith Corporation Lot Number 1 have locating pins in the bomb body and holes in fin assemblies for receiving the locating pins. The reverse is true for bomb bodies and fin assemblies manufactured by the A. O. Smith Corporation subsequent to this lot. Bodies and fin assemblies of the later lots are not interchangeable with bomb bodies and fin assemblies manufactured through Lot Number 1. To ensure that Lot 1 bomb bodies and fin assemblies are

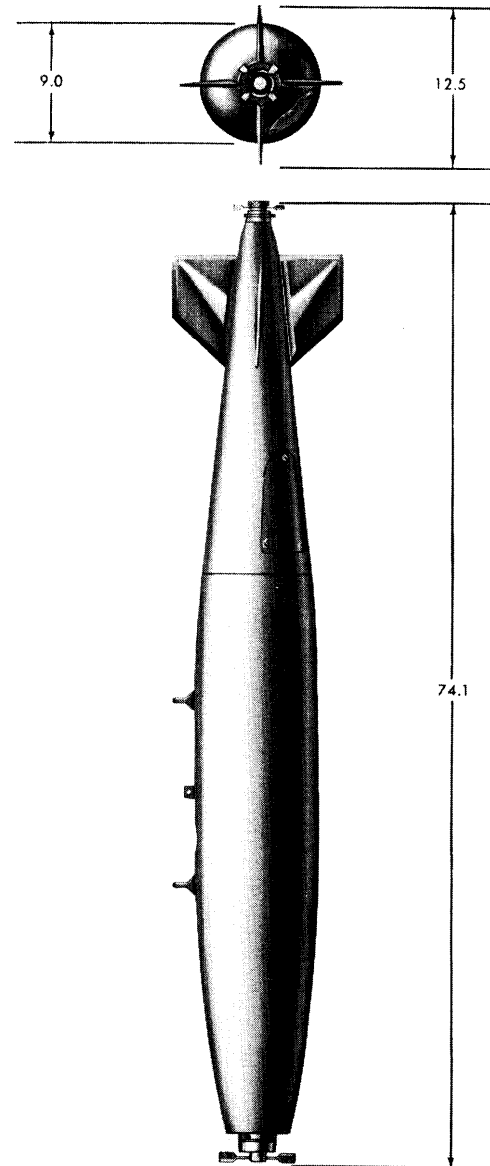

Figure 5.2—250-lb GP Bomb Mk 81 Mod 1
(Mechanically Fuzeed).

not issued with bomb bodies and fin assemblies of later lots, their designation has been changed to Mk 81 Mod 0. Refer to NAVORD Instruction 8150.15.

Physical Characteristics

Weight of assembled fuzed bomb:	
Loaded with 80/20 Tritonal	260 lbs
Weight of explosive:	
Tritonal	100 lbs
Weight of fin:	
Fin Assembly (Dwg 1445672)	15 lbs
Dimensions:	
Length of complete bomb	76.05 inches
Length of bomb body	49.3 inches
Diameter	9.0 inches
Fin span	12.6 inches
Fin length	27.6 inches
Suspension:	
Two suspension lugs	14 inches c to c
Hoisting lug	Center of gravity

Components of a Complete Round (Figures 5.3 and 5.4)

Bomb body assembly (including):

- Bomb body
- Closing plugs
- Suspension lugs
- Hoisting lug

Fin Assembly (Dwg 1445672)

Nose fuze (one of):

- AN-M103A1
- AN-M139A1
- AN-M140A1
- Mk 243 Mod 0
- VT Fuze T750
- VT Fuze AN-M166
- M990 (T905) (electric)

Tail fuze (one of):

- M194 (T791)
- M990 (T905) (electric)

Adapter-boosters (for mechanical fuzing):

- T45E1 (nose)
- T46E4 (tail)

Fahnestock clips (for mechanical fuzing)

Arming wire assembly

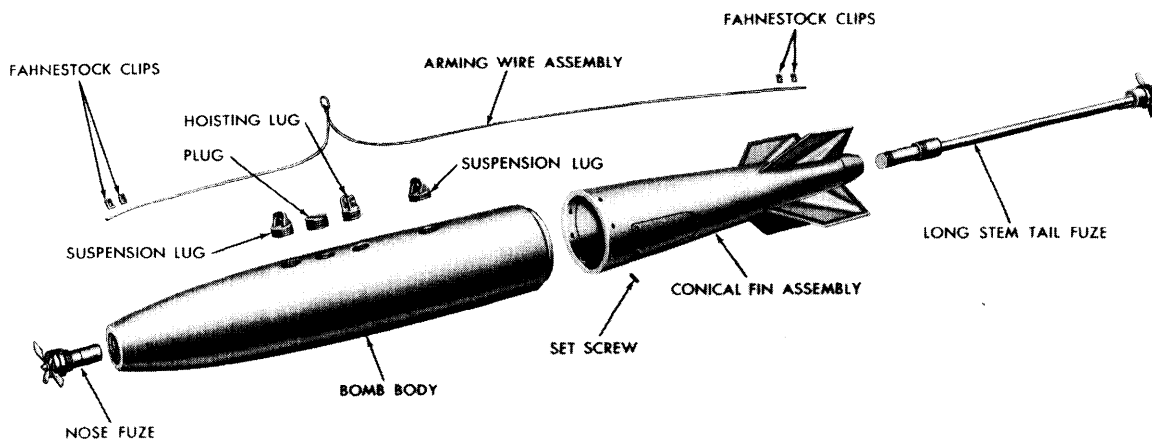

Figure 5.3—250-lb GP Bomb Mk 81 Mod 1 (Mechanically Fuzed), Exploded View.



Figure 5.4—250-lb GP Bomb Mk 81 Mod 1 (Mechanically Fuzed), Cutaway View.

Assembly

CAUTION: Fuzes and bombs shall not be unpacked in advance of requirements. If unpacked and not used, return them to their original packings.

Mechanical Fuzing of GP Bomb Mk 81 Mod 1

1. Remove shipping cap on rear of bomb body.

CAUTION: Inspect for damage (cracks, broken weldments, etc.) which might weaken threaded lug inserts or their attachment to the bomb body.

2. Remove nose plug, base plug, and support cup from nose fuze cavity. Remove hoisting lug from tail fuze cavity. Install required adapter-boosters for mechanical fuzing.

3. Remove fin assembly and suspension lugs from fin shipping crate. Place fin assembly over end of the bomb body with one fin in line with suspension lugs; if suspended in external racks, turn fin and locate to clear aircraft structure and ground, when installed. Butt fin against the aft end of the bomb and secure with setscrews located on the edge of the fin cone. Assemble the two suspension lugs and the hoisting lug in their respective threaded holes.

4. Open access door by unlocking attaching fasteners.

5. Remove fuzes and arming wire assembly from their containers.

CAUTION: If containers are punctured, split, or if the seal is broken in any way, the fuzes contained therein

shall be considered unserviceable. This does not apply to fuzes repacked in the field and resealed with adhesive tape for temporary protection. These fuzes should be examined carefully for serviceability.

6. Insert required tail fuze through opening in rear of fin assembly. Grasp the fuze through the access door opening and screw fuze into fuze well, until handtight. Apply torque to fuze at the body adjacent to the adapter-boosters. Do not apply torque at vane end of fuze.

7. GP Bomb Mk 81 Mod 1 uses the AN-M103A1 series of nose fuzes. If nose fuzing is not used, replace nose plug and support cup, and secure nose plug with setscrew.

8. For detailed information on fuzing and defuzing of Nose Fuze AN-M103A1, refer to OP 988 (First Revision).

9. Install bomb securely on aircraft and sway brace. If bomb bay does not provide enough space for fuzing, fuzing shall be done prior to hoisting bomb into place on the rack.

10. Install arming wire.

Electric Fuzing of GP Bomb Mk 81 Mod 1

Perform the preceding steps 1 through 5, then:

1. Install required electric fuzes.

2. Replace nose fuze-hole and base fuze-hole plugs, and lock plugs with the setscrews provided.

3. Remove plug from charging receptacle cavity.

4. Install bomb securely on aircraft and sway brace. If bomb bay does not provide enough space for fuzing, fuzing shall be done prior to hoisting bomb into place on the rack.

Section 5.3—500-lb GP Bomb Mk 82 Mods 0 and 1

Description

The 500-lb GP Bomb Mk 82 Mod 0 and Mod 1, figure 5.5, has a slender body with a long, pointed nose. A conical-type fin is attached to the aft end of the bomb body by six setscrews.

Bomb Mk 82 may be fuzed mechanically or electrically. Mechanical fuzing requires the installation of adapter-boosters. Two conduits for an electric fuze cable harness connect the nose and tail fuze cavities with the charging receptacle cavity between the lugs on the outer surface of the bomb case. When electric fuzes are not used, a plug is threaded into the charging receptacle cavity.

When fuzes are not installed, the bomb body has a nose fuze-hole plug, a base fuze-hole plug, and a support cup in the nose fuze cavity. When the bomb is fuzed mechanically, these three parts are removed and the adapter-boosters and fuzes are inserted. The nose fuze-hole plug and the base fuze-hole plug are replaced after electric fuzes have been installed. Adapter-boosters are not used with electric fuzes. If the bomb is tail-fuzed only, the support cup must be used in the nose fuze cavity to prevent collapse of the fuze cavity upon heavy impact.

The bomb body has a base plug containing locking pins which are imbedded in the solidified explosive filler. Two suspension lugs spaced 14 inches apart, and a hoisting lug at the center of gravity are threaded into lug inserts on the bomb body.

The high-explosive Tritonal filler is identified by yellow-stenciled nomenclature on the bomb body. The base color of the bomb is olive drab.

Differences Between Mods

Bomb Mk 82 Mod 1 differs from Bomb Mk 82 Mod 0 only in the method used to construct the bomb body.

Physical Characteristics

Weight of assembled fuzed bomb:

Loaded with 80/20 Tri-tonal	512 lbs (Mod 0)
	531 lbs (Mod 1)

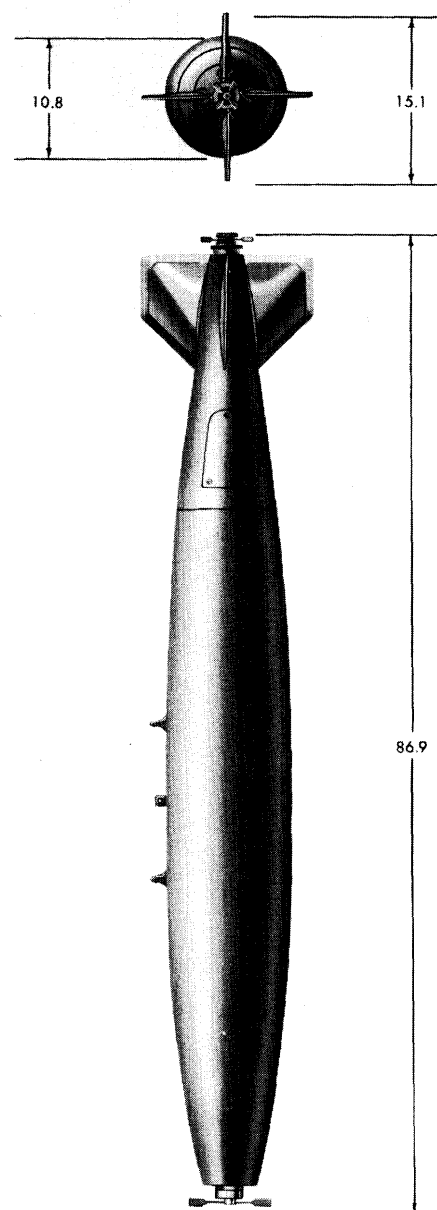

Figure 5.5—500-lb GP Bomb Mk 82 Mod 0 (Mechanically Fuzed).

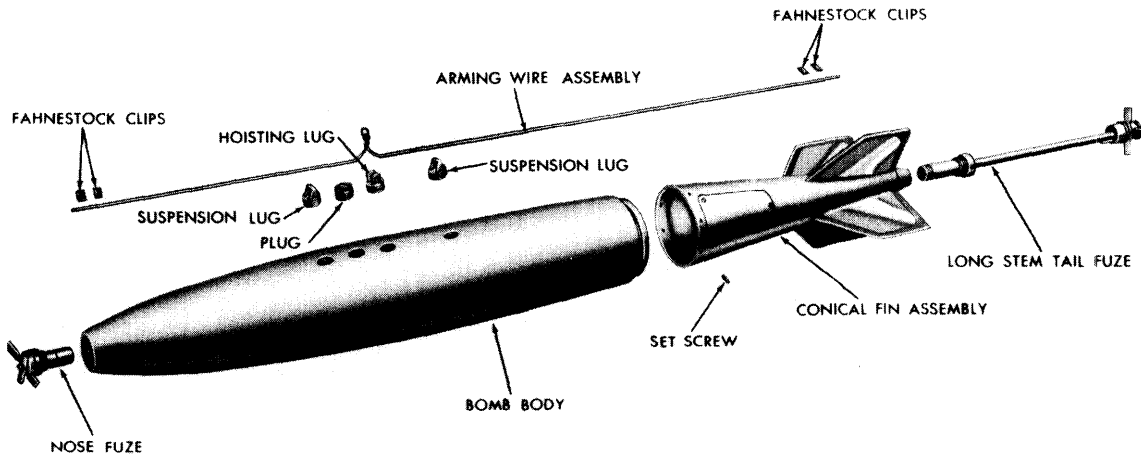

Figure 5.6—500-lb GP Bomb Mk 82 Mod 0 (Mechanically Fuzed), Exploded View.

Weight of explosive:

Tritonal..... 192 lbs

Weight of fin:

Fin Assembly (Dwg 1380512)..... 24 lbs

Dimensions:

Length of complete bomb..... 90.9 inches
 Length of bomb body.. 66.1 inches
 Diameter..... 10.8 inches
 Fin span..... 15.0 inches
 Fin length..... 26.0 inches

Suspension:

Two suspension lugs... 14 inches c to c
 Hoisting lug..... Center of gravity

Components of a Complete Round (Figures 5.6 and 5.7)

Bomb body assembly (including):

- Bomb body
- Closing plugs
- Suspension lugs
- Hoisting lug

Fin Assembly (Dwg 1380512)

Nose fuze (one of):

- AN-M103A1
- AN-M139A1
- AN-M140A
- Mk 243 Mod 0
- VT Fuze T750
- VT Fuze AN-M166
- M990 (T905) (electric)

Tail fuze (one of):

- M195 (T792)
- M990 (T905) (electric)

Adapter-boosters (for mechanical fuzing):

- T45E1 (nose)
- T46E4 (tail)

Fahnestock clips (for mechanical fuzing)

Arming wire assembly

Assembly

CAUTION: Fuzes and bombs shall not be unpacked in advance of requirements. If unpacked and not used, return them to their original packings.



Figure 5.7—500-lb GP Bomb Mk 82 Mod 0 (Mechanically Fuzed), Cutaway View.

**Mechanical Fuzing of GP Bomb Mk 82
Mods 0 and 1**

1. Remove shipping cap on rear of bomb body.

CAUTION: Inspect for damage (cracks, broken weldments, etc.) which might weaken threaded lug inserts or their attachment to the bomb body.

2. Remove nose plug, base plug, and support cup from nose cavity. Remove hoisting lug from tail fuze cavity. Install required adapter-boosters for mechanical fuzing.

3. Remove fin assembly and suspension lugs from fin shipping crate. Place fin assembly over end of the bomb body with one fin in line with suspension lugs; if suspended in external racks, turn and locate fin to clear aircraft structure and ground, when installed. Butt fin against aft end of the bomb and secure with setscrews located on the edge of the fin cone. Assemble the two suspension lugs and the hoisting lug in their respective threaded holes.

4. Open access door by unlocking attaching fasteners.

5. Remove fuzes and arming wire assembly from their containers.

CAUTION: If containers are punctured, split, or if the seal is broken in any way, the fuzes contained therein shall be considered unserviceable. This does not apply to fuzes repacked in the field and resealed with adhesive tape for temporary protection. These

fuzes should be examined carefully for serviceability.

6. Insert required tail fuze through opening in rear of fin assembly. Grasp the fuze through access door opening, and screw fuze into fuze well, until handtight. Apply torque to fuze at body adjacent to the adapter-boosters. Do not apply torque at vane end of fuze.

7. GP Bomb Mk 82 Mods 0 and 1 use the AN-M103A1 series of nose fuzes. If nose fuzing is not used, replace nose plug and support cup, and secure nose plug with setscrew.

8. For detailed information of fuzing and defuzing of Nose Fuze AN-M103A1, refer to OP 988 (First Revision).

9. Install bomb securely on aircraft and sway brace. If bomb bay does not provide enough space for fuzing, fuzing shall be done prior to hoisting bomb into place on the rack.

10. Install arming wire.

**Electric Fuzing of GP Bomb Mk 82 Mods
0 and 1**

Follow the preceding steps 1 through 5, then:

1. Install required electric fuzes.

2. Replace nose fuze-hole and base fuze-hole plugs, and lock plugs with the setscrews provided.

3. Remove plug from charging receptacle cavity.

4. Install bomb securely on aircraft and sway brace. If bomb bay does not provide enough space for fuzing, fuzing shall be done prior to hoisting bomb into place on the rack.

Section 5.4—1000-lb GP Bomb Mk 83 Mods 2 and 3

Description

The 1000-lb GP Bomb Mk 83 Mods 2 and 3 have a slender body with a long, pointed nose. A conical-type fin is attached to the aft end of the bomb body by six setscrews.

Bomb Mk 83 uses either mechanical or electric fuzes. Mechanical fuzing, figure 5.8, requires installation of adapter-boosters. Two conduits for an electric fuze cable harness connect the nose and tail fuze cavities with the charging receptacle cavity between the lugs on the outer surface of the bomb case. When electric fuzes are not used, a plug is threaded into the charging receptacle cavity.

When fuzes are not installed, the bomb body has a nose fuze-hole plug, a base fuze-hole plug, and a support cup in the nose fuze cavity. When the bomb is fuzed mechanically, these three parts are removed and the adapter-boosters and fuzes are inserted. The nose fuze-hole plug and base fuze-hole plug are replaced after electric fuzes have been installed. Adapter-boosters are not used with electric fuzes. If the bomb is tail-fuzed only, the support cup must be used in the nose fuze cavity to prevent collapse of the fuze cavity upon heavy impact.

The bomb body has a base plug containing locking pins which are imbedded in the solidified explosive filler. Double suspension lugs spaced 14 inches apart, and a hoisting lug at the center of gravity are threaded into lug inserts on the bomb body.

The high-explosive Tritonal filler is identified by yellow-stenciled nomenclature on the bomb. The base color of the bomb is olive drab.

Differences Between Mods

Low-drag GP Bomb Mk 83 consists of the Mod 2 and the Mod 3. Differences lie in the methods used in the construction of the bomb bodies.

Physical Characteristics

Weight of assembled fuzed bomb:
 Loaded with 80/20 Tri-
 tonal..... 985 lbs

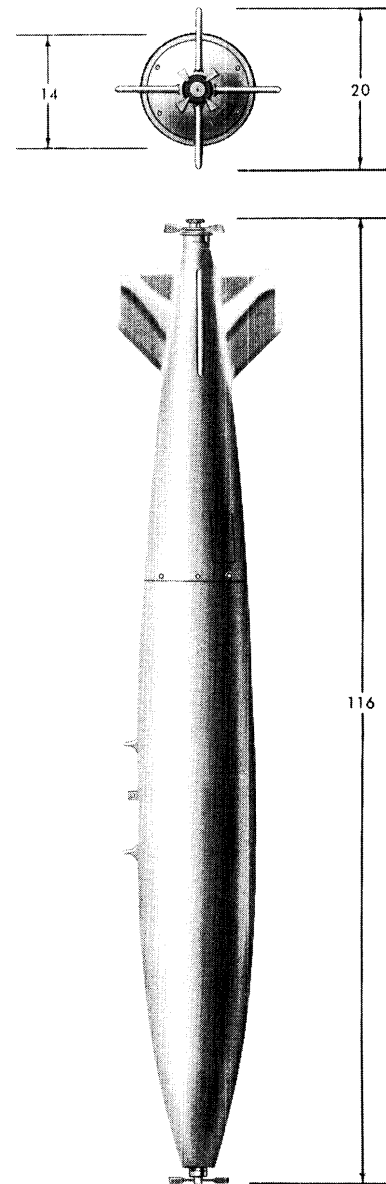

Figure 5.8—1000-lb GP Bomb Mk 83 Mod 2
 (Mechanically Fuzed).

Weight of explosive:
 Tritonal..... 445 lbs

Weight of fin:
 Fin assembly..... 55 lbs

Dimensions:
 Length or height of complete bomb..... 119 inches
 Length of bomb body.. 77 inches
 Diameter..... 14 inches
 Fin span..... 20 inches
 Fin length..... 42 inches

Suspension:
 Two suspension lugs... 14 inches c to c
 One hoisting lug..... Center of gravity

Components of a Complete Round (Figures 5.9 and 5.10)

- Bomb body assembly (including):
 - Bomb body
 - Closing plugs
 - Suspension lugs
 - Hoisting lug
- Nose fuze (one of):
 - AN-M103A1
 - AN-M139A1
 - AN-M140A1
 - Mk 243 Mod 0
 - VT Fuze T750
 - VT Fuze AN-M166
 - M990 (T905) (electric)
- Tail fuze (one of):
 - M185 (T740)
 - M177 (T745)
 - M990 (T905) (electric)
- Adapter-boosters (for mechanical fuzing):
 - T45E1 (nose)
 - T46E4 (tail)
- Fahnestock clips (for mechanical fuzing)
- Arming wire assembly

Assembly

CAUTION: Fuzes and bombs shall not be unpacked in advance of requirements. If unpacked and not used, return them to their original packings.

Mechanical Fuzing of Bomb Mk 83 Mods 2 and 3

1. Remove shipping cap on rear of bomb body by removing hex-head bolts.

CAUTION: Inspect for damage (cracks, broken weldments, etc.) which might weaken threaded lug inserts or their attachment to the bomb body.

2. Remove nose fuze-hole plug, base fuze-hole plug, and support cup from nose fuze cavity. Remove hoisting lugs from tail fuze cavity. Install required adapter-boosters for mechanical fuzing.

3. Remove fin assembly and suspension lugs from fin shipping crate. Place fin assembly over end of the bomb body with one fin in line with suspension lugs; if suspended in external racks, turn and locate fin to clear aircraft structure and ground, when installed. Butt fin against aft end of the bomb and secure with setscrews located on the edge of the cone. Assemble the two suspension lugs and the hoisting lug in their respective threaded holes.

4. Open access door by unlocking attaching fasteners.

5. Remove fuzes and arming wire assembly from their containers.

CAUTION: If containers are punctured, split, or if the seal is broken in any way, the fuzes contained therein shall be considered unserviceable. This does not apply to fuzes repacked in the field and resealed with adhesive tape for temporary protection. These fuzes should be examined carefully for serviceability.

6. Insert required tail fuze through opening on rear of the fin assembly. Grasp the fuze through the access door opening, and screw fuze into fuze well, until handtight. Apply torque to fuze at body adjacent to adapter-booster. Do not apply torque at vane end of fuze.

7. Mk 83 Mod 2 and Mod 3 use the AN-M103A1 series nose fuze.

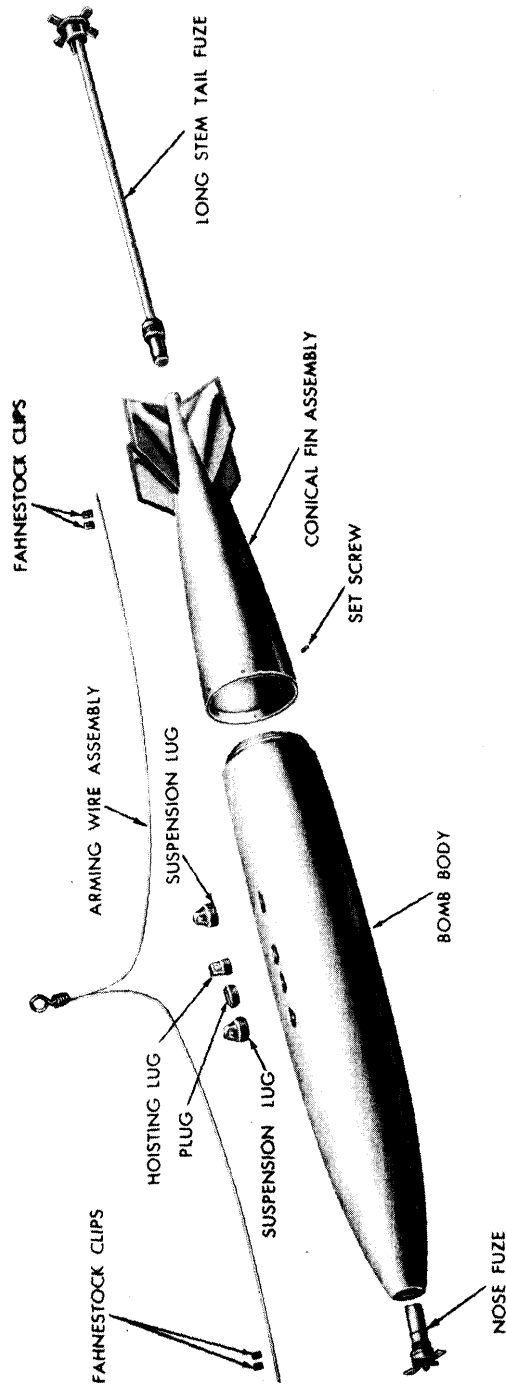

Figure 5.9—1000-lb GP Bomb Mk 83 Mod 2 (Mechanically Fuzed), Exploded View.

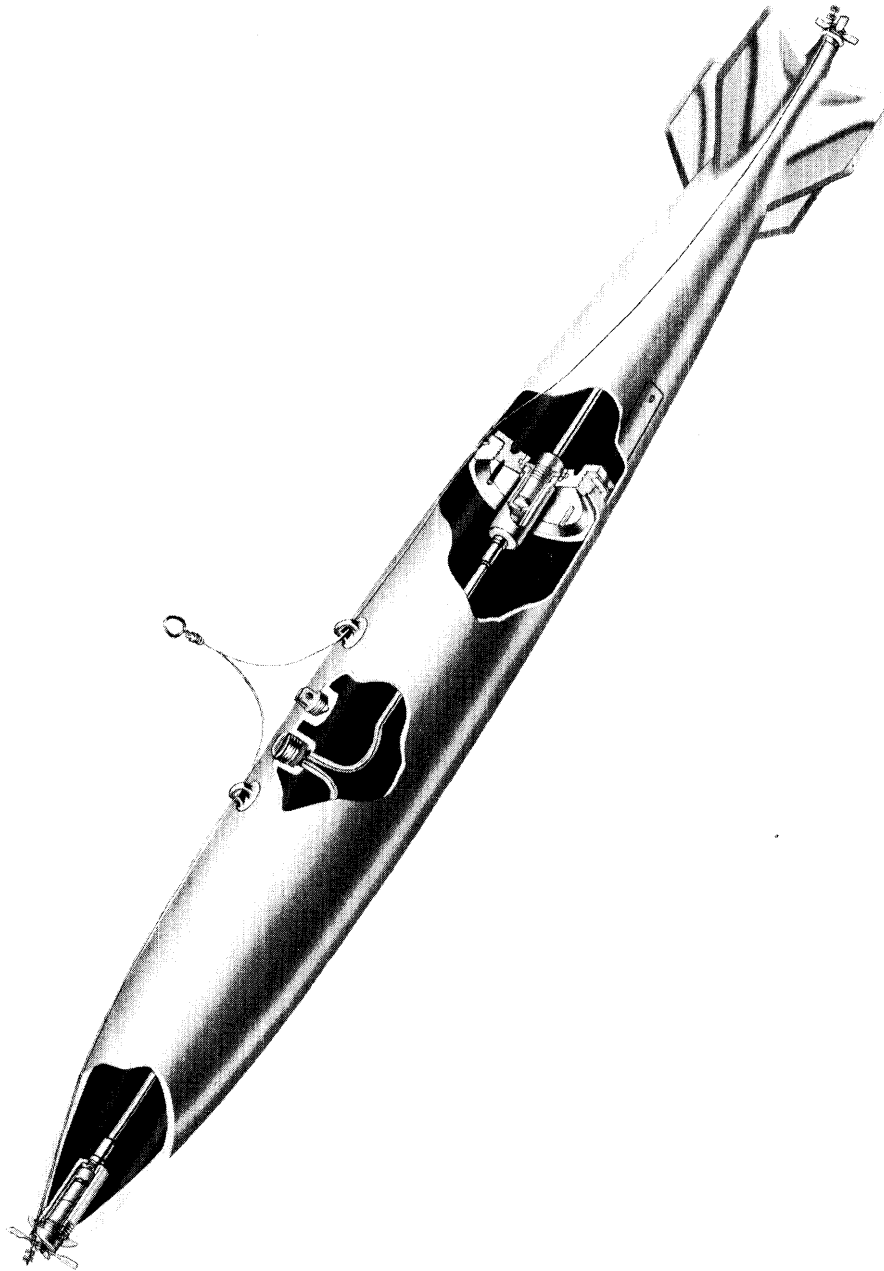

Figure 5.10—1000-lb GP Bomb Mk 83 Mod 2 (Mechanically Fuzed), Cutaway View.

8. For detailed information on fuzing and defuzing of Nose Fuze AN-M103A1, refer to OP 988 (First Revision).

9. Install bomb securely on aircraft and sway brace. If bomb bay does not provide enough space for fuzing, fuzing shall be done prior to hoisting bomb into place on the rack.

10. Install arming wire.

NOTE: On certain aircraft, the arming wire leading to Tail Fuze M185 (T740) or M177 (T745) has been observed to whip during high-speed flight. To reduce this whipping action of the arming wire, at least one arming wire guide should be installed at approximately the midway point on the tail cone of the fin assemblies for Bomb

Mk 83 Mods 2 and 3. A standard eyebolt, Navy Stock Catalog No. R43B63012, which can be installed easily on the fin assembly is a suitable arming wire guide.

Electric Fuzing of GP Bomb Mk 83 Mod 2 and Mod 3

Follow the preceding steps 1 through 5, then:

1. Install required electrical fuzes.
2. Replace nose fuze-hole and base fuze-hole plugs and secure in place with setscrews.
3. Remove charging receptacle plug.
4. Install bomb securely on aircraft and sway brace. If bomb bay does not provide enough space for fuzing, fuzing shall be done prior to hoisting bomb into place on the rack.

Section 5.5—2000-lb GP Bomb Mk 84 Mod 1

Description

The 2000-lb GP Bomb Mk 84 Mod 1 has a slender body with a long, pointed nose. A conical-type fin is attached to the aft end of the bomb body by eight setscrews.

Bomb Mk 84 Mod 1 uses either mechanical or electric fuzes. Mechanical fuzeing, figure 5.11, requires the installation of adapter-boosters. Two conduits for an electric fuze cable harness connect the nose and tail fuze cavities with the charging receptacle cavity between the lugs on the outer surface of the bomb case. When electric fuzes are not used, a plug is threaded into the charging receptacle opening.

When fuzes are not installed, the bomb body has a nose fuze-hole plug, a base fuze-hole plug, and a support cup in the nose fuze cavity. When the bomb is fuzeed mechanically, these three parts are removed and the adapter-boosters and fuzes are inserted. The nose fuze-hole plug and the base fuze-hole plug are replaced after electric fuzes have been installed. Adapter-boosters are not used with electric fuzes. If the bomb is tail-fuzed only, the support cup must be used in the nose fuze cavity to prevent collapse of the fuze cavity upon heavy impact.

The bomb body has a base plug containing locking pins which are imbedded in the solidified explosive filler. Double suspension lugs spaced 30 inches apart, and a hoisting lug located at the center of gravity are threaded into lug inserts on the bomb body.

The high-explosive Tritonal filler is identified by yellow-stenciled nomenclature on the bomb. The base color of the bomb is olive drab.

Physical Characteristics

Weight of assembled fuzeed bomb:
 Loaded with 80/20 Tri- 1970 lbs
 tonal.

Weight of explosive
 Tritonal 945 lbs

Weight of fin:
 Fin assembly 80 lbs

Dimensions:
 Length or height of 154.0 inches
 complete bomb

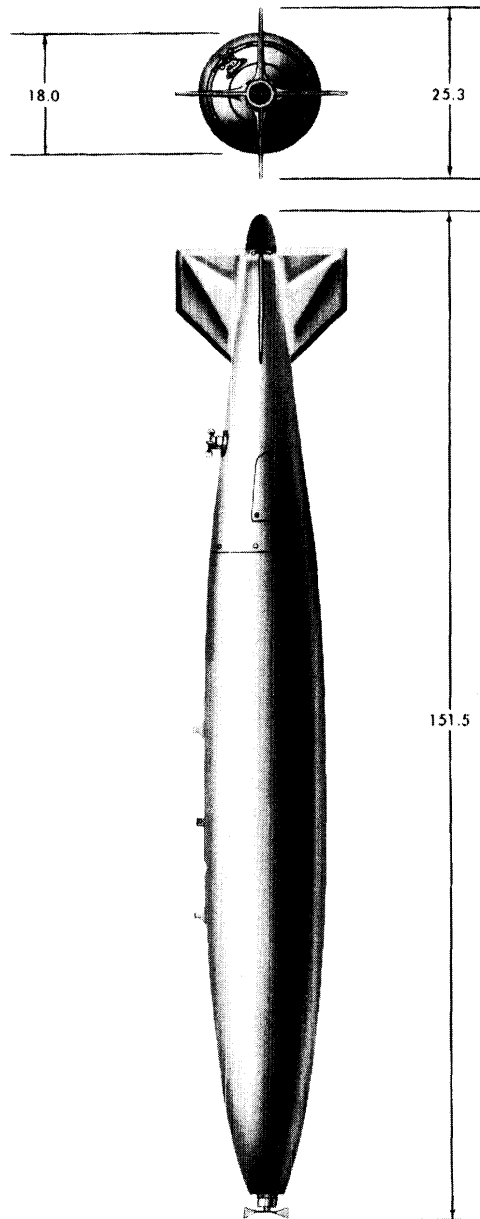

Figure 5.11—2000-lb GP Bomb Mk 84 Mod 1 (Mechanically Fuzeed).

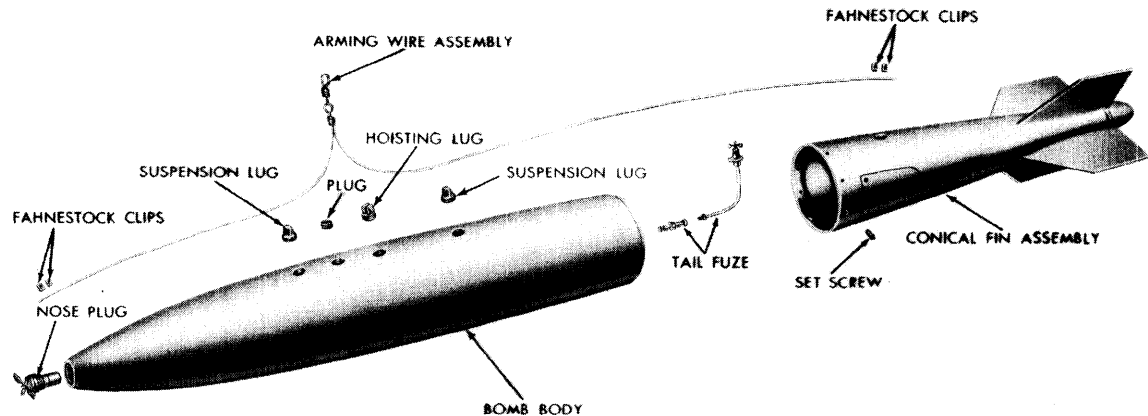

Figure 5.12—2000-lb GP Bomb Mk 84 Mod 1 (Mechanically Fuzed), Exploded View.

Dimensions—Continued

Length of bomb body	102.6 inches
Diameter	18.0 inches
Fin span	25.3 inches
Fin length	53.1 inches

Suspension:

Two suspension lugs	30 inches c to c
One hoisting lug	Center of gravity

Components of a Complete Round (Figures 5.12 and 5.13)

Bomb body assembly (including):

Bomb body
Closing plugs
Suspension lugs
Hoisting lug

Fin assembly

Nose fuze (one of):

AN-M103A1
AN-M139A1
AN-M140A1
VT Fuze T750
VT Fuze AN-M166
M990 (T905) (electric)

Tail fuze (one of):

M190 (T759)
M990 (T905) (electric)

Adapter-boosters (for mechanical fuzing):

T45E1 (nose)
T46E4 (tail)

Fahnestock clips (for mechanical fuzing)

Arming wire assembly

Assembly

CAUTION: Fuzes and bombs shall not be unpacked in advance of requirements. If unpacked and not used, return them to their original packings.

Mechanical Fuzing of GP Bomb Mk 84 Mod 1

1. Remove shipping cap on rear of bomb. **CAUTION:** Inspect for damage (cracks, broken weldments, etc.) which might weaken threaded lug inserts or their attachment to the bomb body.
2. Remove nose fuze-hole plug, base fuze-hole plug, and support cup from nose fuze cavity. Remove hoisting lug from tail fuze cavity. Install required adapter-boosters for mechanical fuzing.
3. Remove fin assembly and the suspension lugs from fin shipping crate. Place fin assembly over end of the bomb body so that the pin in the fin assembly aligns with a hole in the body. Butt fin against aft end of the bomb and secure with setscrews located on the edge of the fin cone. Assemble the two suspension lugs and the hoisting lug in their respective threaded holes.
4. Open access door by unlocking attaching fasteners.
5. Remove required fuzes and arming wire assembly from their containers.

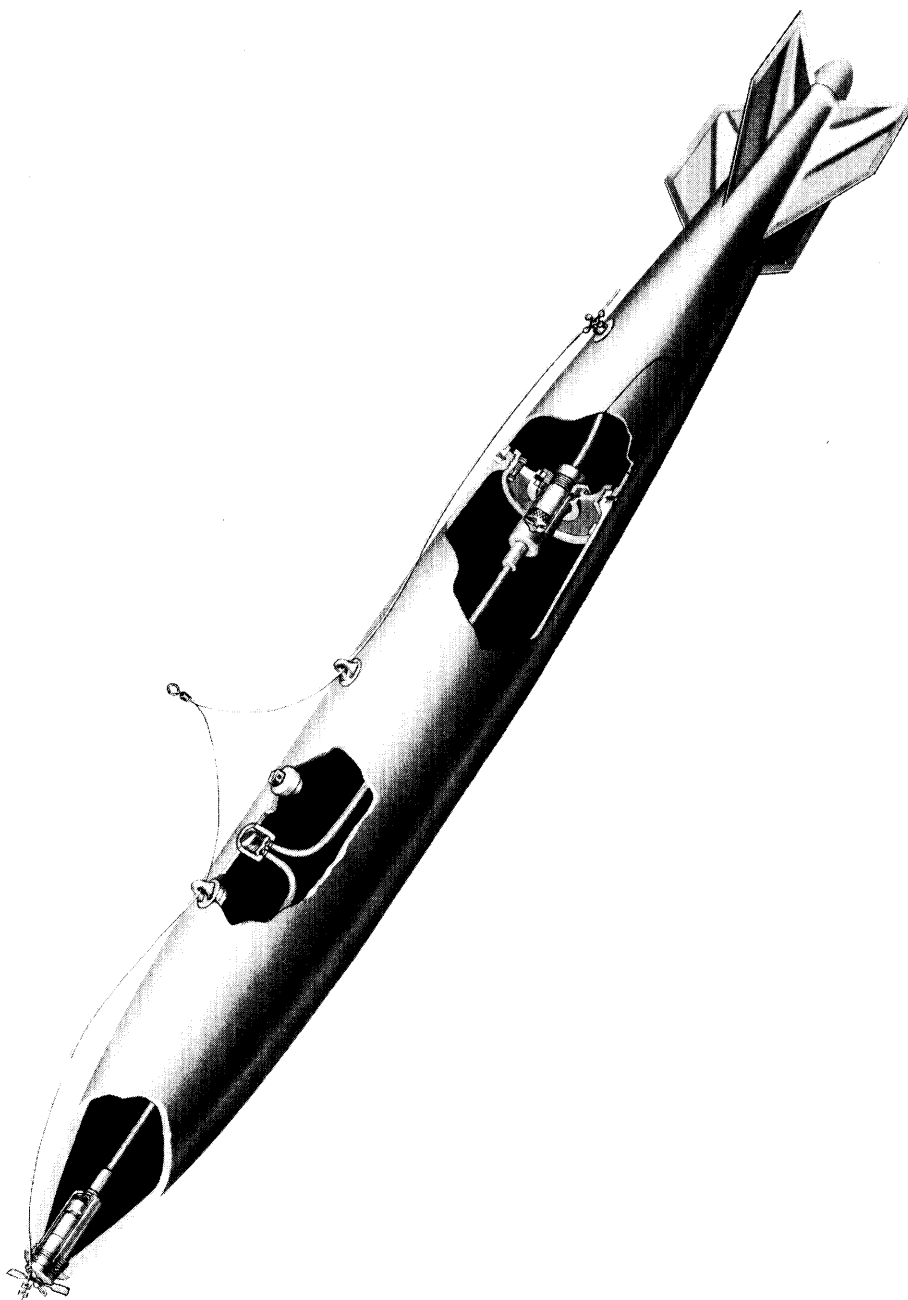

Figure 5.13—2000-lb GP Bomb Mk 84 Mod 1 (Mechanically Fuzed), Cutaway View.

CAUTION: If containers are punctured, split, or if the seal is broken in any way, the fuzes contained therein shall be considered unserviceable. This does not apply to fuzes repacked in the field and resealed with adhesive tape for temporary protection. These fuzes should be examined carefully for serviceability.

6. Insert required tail fuze through opening in rear of fin assembly. Grasp the fuze through the access door opening, and screw fuze into fuze well, until handtight. Apply torque to fuze at the body adjacent to the adapter-booster. Do not apply torque at vane end of fuze.

7. GP Bomb Mk 84 Mod 1 uses Nose Fuze AN-M103A1, or its equivalent.

8. For detailed information on fuzing and defuzing of Nose Fuze AN-M103A1, refer to OP 988 (First Revision).

9. Install bomb securely on aircraft and

sway brace. If bomb bay does not provide enough space for fuzing, fuzing shall be done prior to hoisting bomb into place on the rack.

10. Install arming wire by threading wire through forward suspension lug. Arming wire should protrude approximately 2 inches beyond fuze vanes. Cut off excess wire. Arming wire should be free from kinks, twists, and burrs.

Electric Fuzing of GP Bomb Mk 84 Mod 1

Follow the preceding steps 1 through 5, then:

1. Install required electric fuzes.
2. Replace nose fuze-hole and base fuze-hole plugs, and lock plugs with the setscrews provided.
3. Remove plug from charging receptacle cavity.
4. Install bomb securely on aircraft and sway brace. If bomb bay does not provide enough space for fuzing, fuzing shall be done prior to hoisting bomb into place on the rack.

Chapter 6

FRAGMENTATION BOMBS

Section 6.1—General

Section 6.2—4-lb Fragmentation Bomb M83

Section 6.3—20-lb Fragmentation Bomb AN-M41A1

Section 6.4—90-lb Fragmentation Bomb M82

Section 6.5—220-lb Fragmentation Bomb AN-M88 with Fin Assembly AN-M103A1

Section 6.6—220-lb Fragmentation Bomb AN-M88 with Fin Assembly M135

Section 6.7—260-lb Fragmentation Bomb AN-M81 with Fin Assembly AN-M103A1

Section 6.8—260-lb Fragmentation Bomb AN-M81 with Fin Assembly M135

Chapter 6

FRAGMENTATION BOMBS

Section 6.1—General

Description

Fragmentation (frag) bombs usually are constructed of seamless steel tubing covered with spirally wound, square steel wire. The seamless steel bodies usually are of one-piece construction, swaged at each end with the wire extending to both ends of the bomb body. However, some models of these bombs have cast nose and tail sections that are threaded into a central, cylindrical steel tubing; the tubing is the only part of the body that is wire-wrapped.

Small fragmentation bombs are nose-fuzed only and have tail caps threaded to receive a four-bladed fin assembly or a small parachute unit. These small bombs may be suspended either horizontally or vertically in the aircraft and commonly are used in cluster assemblies.

Larger fragmentation bombs (over 90 pounds) are used individually and are equipped with box-type or conical fin assemblies. Fragmentation bombs, 220 pounds and larger, are adapted for both nose and tail fuzeing.

The 4-lb Fragmentation Bomb M83 differs in its shape and manner of issue from the other

fragmentation bombs. It is a small, cylindrical metal bomb issued only in bomb clusters or in wafers. The fuze, placed in the bomb and set at the time of manufacture, has a cable extension on which the bomb case assembly (butterfly wings) is mounted. When the bomb is released from the cluster, the butterfly wings spring open and rotate on the cable, retarding the fall of the bomb and arming the fuze.

Usage

Direct hits or near misses are required for fragmentation bombs. Destruction is caused by fragmentation of the bomb case; therefore, the target must be in the bomb's effective radius of projected fragments. The explosive charge may consist of Amatol 50/50, Composition B, or TNT.

Fragmentation Bombs (Figure 6.1)

- 4-lb Fragmentation Bomb M83
- 20-lb Fragmentation Bomb AN-M41A1
- 90-lb Fragmentation Bomb M82
- 220-lb Fragmentation Bomb AN-M88
- 260-lb Fragmentation Bomb AN-M81

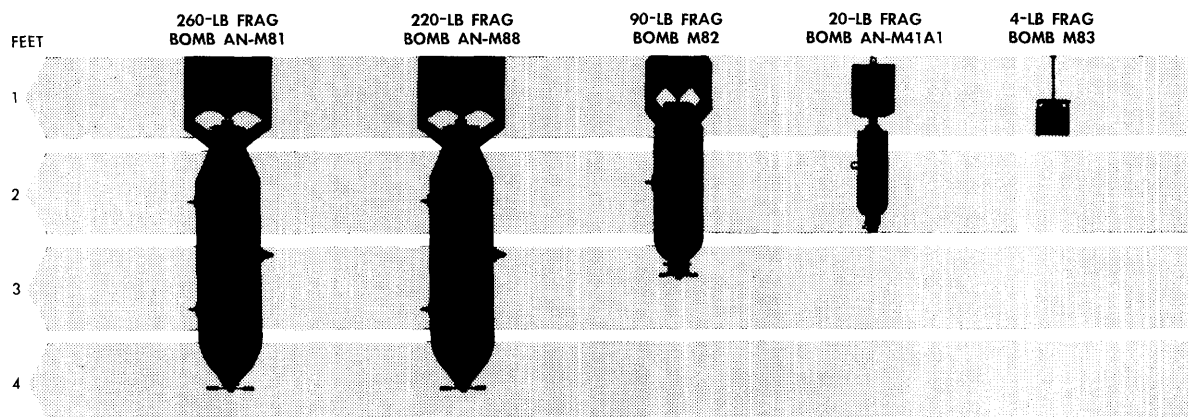

Figure 6.1—Fragmentation Bombs, Comparative Size.

Fuzes Compatible with Fragmentation Bombs

Nose fuzes:

AN-M158
 AN-M103A1
 VT Fuze AN-M166
 VT Fuze AN-M168

Side fuzes: (for Bomb M83 only):

M129
 M130
 M131

Tail fuzes:

AN-M100A2
 M172
 M175

Markings

The high-explosive content of fragmentation bombs is indicated by yellow bands which encircle the bomb body. Small fragmentation bombs (under 90 pounds) have yellow-painted nose and tail sections with the exception of the 4-lb Fragmentation Bomb M83 which has a ½-inch yellow band on each side of its body. Standard nomenclature is stenciled in black letters on the bomb body and its components. The following information is given for identification of fragmentation bombs:

Type
 Weight
 Model
 Filler—(Comp B, TNT)
 Ammunition lot numbers
 US (in letters)
 Inspector's stamp
 AIC symbol
 ICC shipping designation
 Displacement
 Address
 Shipping ticket number

Suspension

Most fragmentation bombs can be suspended either singly or doubly by means of lugs welded to the case. A single lug is welded on one side of the bomb case, and double suspension lugs are located diametrically opposite. Smaller fragmentation bombs, up to 90 pounds, usually are used in clusters. The 20-lb fragmentation bombs have a single suspension lug welded to the bomb body for individual suspension and use. In addition, a suspension eye, located

at the end of the fin assembly, is provided. The 4-lb Fragmentation Bomb M83 is issued in wafers which are held together with metal bands. Groups of wafers are assembled to form a cluster.

Safety Precautions

Except for the small bombs (4 pounds and 20 pounds), the fragmentation bomb bodies and attaching components are shipped as separate units and are assembled before installation in the bomb rack. Preparing bombs for flight requires extreme care, because a mis-step may prove fatal.

Safety Precautions To Be Observed

1. Fuzes and bombs shall not be unpacked in advance of requirements. If unpacked and not used, return them to their original packings.
2. Detonator holders shall not be assembled to fuzes and fuzes shall not be assembled to bombs, in anticipation of future needs.
3. Any accidentally armed fuze, either fully or partially armed, shall be handled by authorized personnel only.
4. Authorized personnel shall dispose of defective bombs and fuzes.
5. Never remove safety cotter pins or car seals from fuzes prematurely.
6. Guard fuzes against dropping or bumping at tall times, to prevent accidental detonation.
7. Never allow primer detonators to drop or strike an object; they are extremely sensitive and rough handling will explode them.
8. Screw fuzes into bomb **HANDTIGHT ONLY**. Use only tools authorized.
9. Handle and install fuze arming vanes carefully to prevent distortion of blades.
10. Do **NOT** remove warning tag after fuze is installed in bomb.
11. Never use a fin assembly if it cannot be secured to the bomb properly. If fin assembly is loose and turns on the bomb, it may pull the arming wire from the tail fuze, allowing the fuze to arm before the bomb is dropped.
12. Inspect arming wire for kinks, twists, or burrs; such defects may cause a bomb to hang in the bomb bay, after release.
13. Replace all safety pins prior to defuzing a bomb.

Section 6.2—4-lb Fragmentation Bomb M83

Description

The 4-lb Fragmentation Bomb M83, figure 6.2, is a small, barrel-shaped bomb. The fuze, assembled at the time of manufacture, is mounted on the bomb case midway between the cylinder ends. Two semi-cylindrical surfaces (butterfly wings) and two discs (propeller blades) are spring-hinged together, independent of the bomb. In the unarmed position, these four pieces, or vanes, are folded about the cylindrical bomb forming a cylindrical outer bomb casing. A cable extension projects from the fuze through the folded outer bomb casing.

The 4-lb fragmentation bomb uses Fuze M129, M130 or M131. Fuze firing actions, impact, mechanical time-delay, and anti-disturbance are obtained by selection of the appropriate fuze. The fuzes are installed and their actions are set at the time of manufacture.

M83 bombs are issued in clusters of the M28 and M29 series or in the form of bomb wafers to be assembled in clusters in the field.

In the cluster, the four bomb vanes are held against the bomb by contact with other bombs of the cluster. A provision is made to permit clipping or wiring the vanes of unclustered bombs in the closed or unarmed position. When the bombs are released from the cluster, the wings open by spring-action and are forced by the airstream to the top of the cable extension where they lock in place. In this position, the butterfly wings begin to rotate and retard the fall of the bomb. The rotation of the wings (or vanes) turns the cable and withdraws the arming stem, arming the fuze.

Approximately 12 percent of the complete bomb weight is explosive filler, Composition B or TNT. The bomb is painted olive drab; yellow color bands and black-stenciled nomenclature identify the bomb and its high-explosive content.

Physical Characteristics

Weight of assembled bomb:	
Loaded with Composition B	3.82 lbs
Loaded with TNT	3.80 lbs

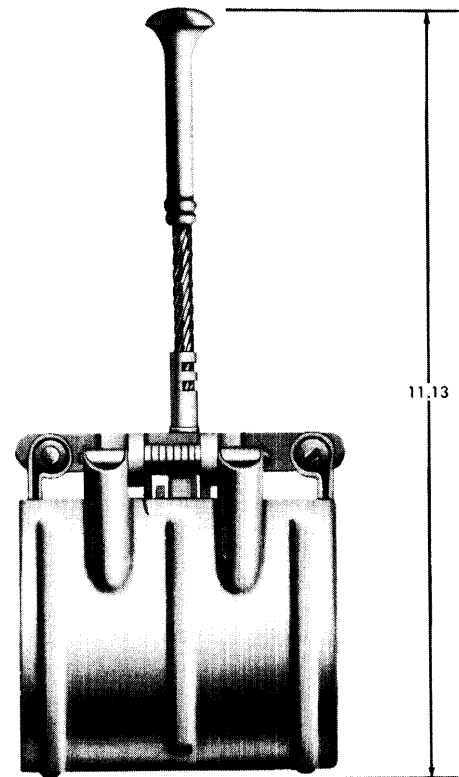
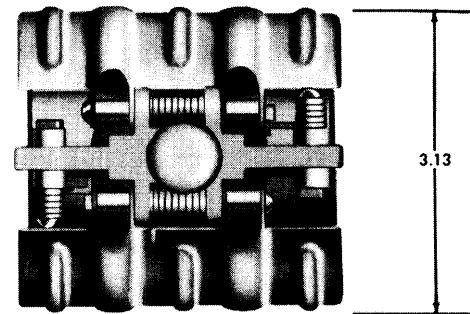

Figure 6.2—4-lb Fragmentation Bomb M83.

Weight of explosive:

Comp B..... 0.99 lbs
 TNT..... 0.40 lbs

Dimensions:

Length or height of complete bomb 11.13 inches
 Length of bomb body..... 2.82 inches
 Diameter..... 3.13 inches
 Butterfly wing span..... 9.5 inches
 Butterfly wing length..... 3.0 inches

Suspension:

Not suspended singly; used in cluster only.

Components of a Complete Round (Figure 6.3)

Bomb body assembly (including):

Bomb body
 Cable assembly
 Case assembly

Fuzes (one of):

M129 (impact)
 M130 (mechanical time-delay)
 M131 (anti-disturbance)

Assembly

1. The 4-lb Fragmentation Bomb M83 is shipped from the manufacturer in wafer assemblies which are bound with two metal straps. The wafer assemblies are individually packed in metal-lined wafer boxes and are secured to plywood inserts. Fuzes are installed and set at the factory.

CAUTION: Never attempt to remove the fuzes, change the setting, or perform any work on the fuzes.

2. Always handle wafers by the cable assemblies (pigtailed) or by the flat side. Do not handle by the strapping.

3. For general precautions and the detailed chronological procedures for handling and installing the 4-lb Fragmentation Bomb M83 wafers, refer to section 7.3.

CAUTION: Follow the assembly operation procedures carefully. Failure to follow directions precisely may permit the bomb to spring out of the cluster and the case assemblies (butterfly wings) to open.

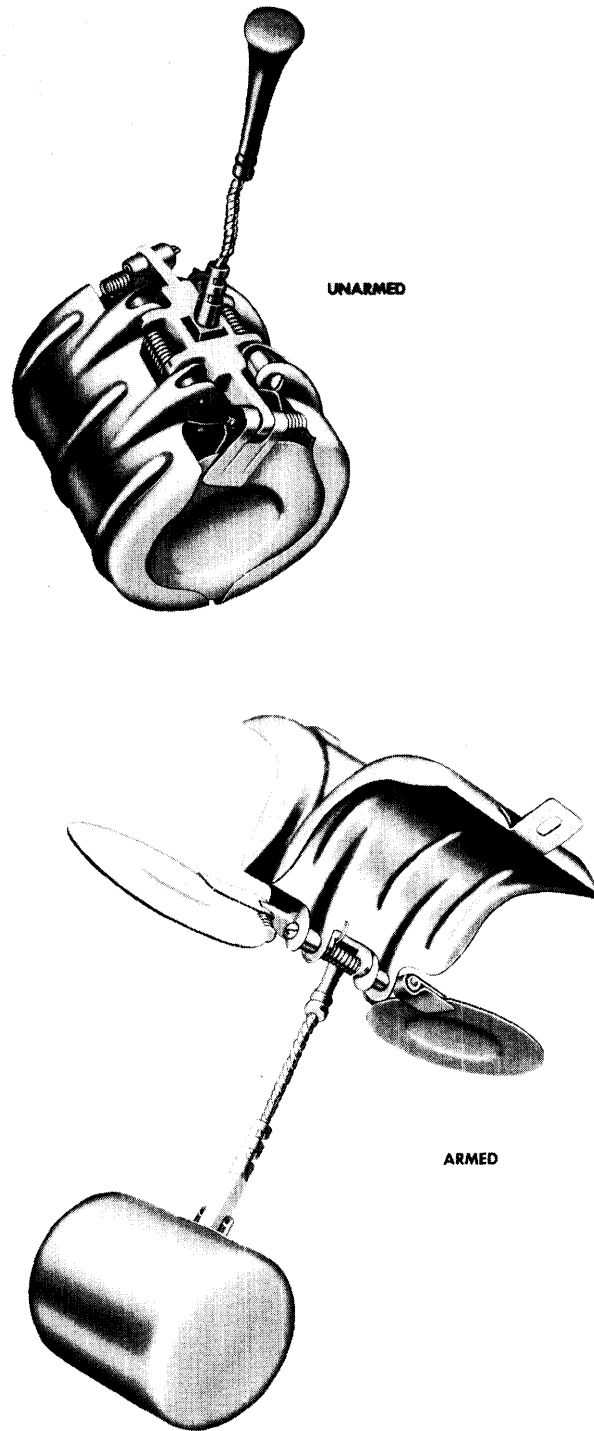

Figure 6.3—4-lb Fragmentation Bomb M83 (Armed and Unarmed Positions).

Section 6.3—20-lb Fragmentation Bomb AN-M41A1

Description

The 20-lb Fragmentation Bomb AN-M41A1, figure 6.4, is constructed of spirally wound wire and cast-steel nose and tail pieces. A seamless steel inner tube is threaded to the nose and tail piece to form the base for the spiral-wound wire. The fin assembly is made of four rectangular sheet-steel vanes welded to a one-inch diameter pipe. The threaded end of the pipe is secured to the base filling plug. The nose section of the bomb is threaded to receive an impact fuze.

The 20-lb Fragmentation Bomb AN-M41A1 is used in the 100-lb Fragmentation Bomb Cluster AN-M1A1 and in the 500-lb Fragmentation Bomb Clusters M26 and M26A2.

At the center of gravity, a U-shaped eyebolt of steel is welded to the bomb case for horizontal suspension; an eyebolt is welded to the tail for vertical suspension.

Approximately 13 percent of the complete weight of Fragmentation Bomb AN-M41A1 is explosive filler, Amatol 50/50 or TNT. A yellow-colored head and base identify the high-explosive filler of the 20-lb Fragmentation Bomb AN-M41A1. Identifying nomenclature is stenciled in black on the bomb body. The bomb body windings are painted olive drab.

Differences Between Bombs AN-M41 and AN-M41A1

Bomb AN-M41, the earlier model, differs from AN-M41A1 in length. A change in construction added a 1/2-inch shoulder to the nose of the bomb; this change in design alone constitutes the "A1" modification. Fragmentation Bomb AN-M41 is issued only in cluster form.

Physical Characteristics

- Weight of assembled fuzeed bomb:
 - Loaded with Amatol 50/50 19.7 lbs
 - Loaded with TNT 19.8 lbs
- Weight of explosive:
 - AM 50/50 2.57 lbs
 - TNT 2.7 lbs

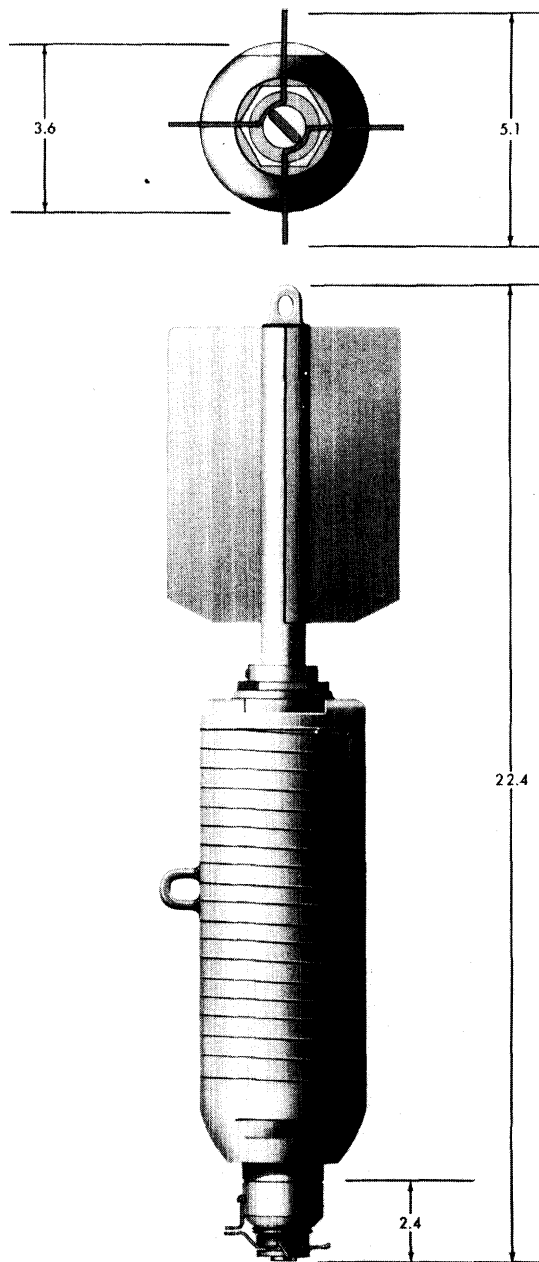

Figure 6.4—20-lb Fragmentation Bomb AN-M41A1.

Weight of fin:	1.6 lbs
Dimensions:	
Length or height of complete bomb	22.4 inches
Length of bomb body	11.5 inches
Diameter	3.64 inches
Fin span	5.13 inches
Fin length	9.4 inches
Suspension:	
Single suspension lug	Center of gravity
Vertical suspension lug	End of fin assembly

Components of a Complete Round (Figures 6.5 and 6.6)

- Bomb body assembly (including):
 - Bomb body
 - Closing plugs
- Fin assembly
- Nose fuze:
 - AN-M158

Assembly

1. This bomb usually is found in bomb

clusters which are assembled completely except for fuzes.

CAUTION: Fuzes shall not be unpacked in advance of requirements. If unpacked and not used, return them to their original packings.

2. Remove bomb closing plug. Inspect threads, clean if necessary.
3. Remove fuze from its container.

CAUTION: If containers are punctured, split, or if the seal is broken in any way, the fuzes contained therein shall be considered unserviceable. This does not apply to fuzes repacked in the field and resealed with adhesive tape for temporary protection. These fuzes should be examined carefully for serviceability.

4. Nose Fuze AN-M158 is used with the 20-lb Fragmentation Bomb AN-M41A1.

5. For detailed information on fuzing and defuzing, refer to OP 988 (First Revision).

CAUTION: Do not remove safety cotter-pin locking arm mechanism of nose fuze.

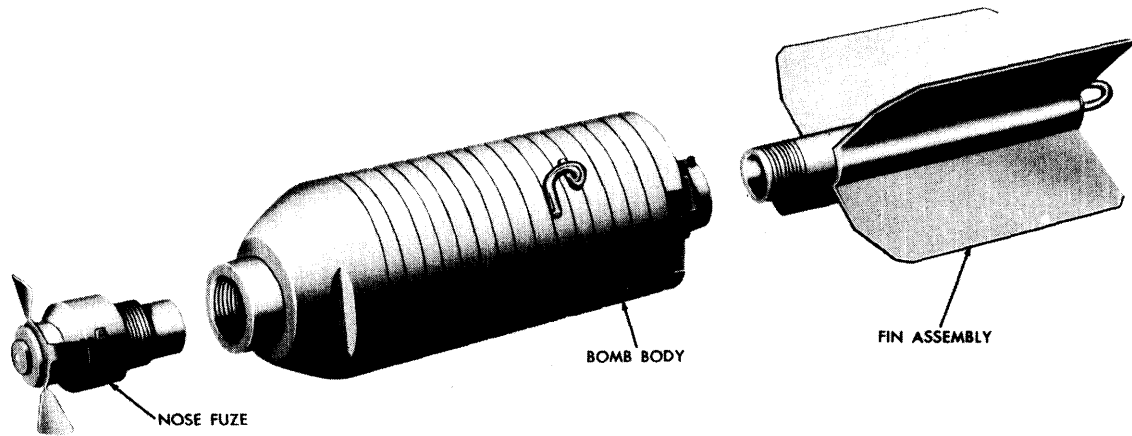

Figure 6.5—20-lb Fragmentation Bomb AN-M41A1, Exploded View.

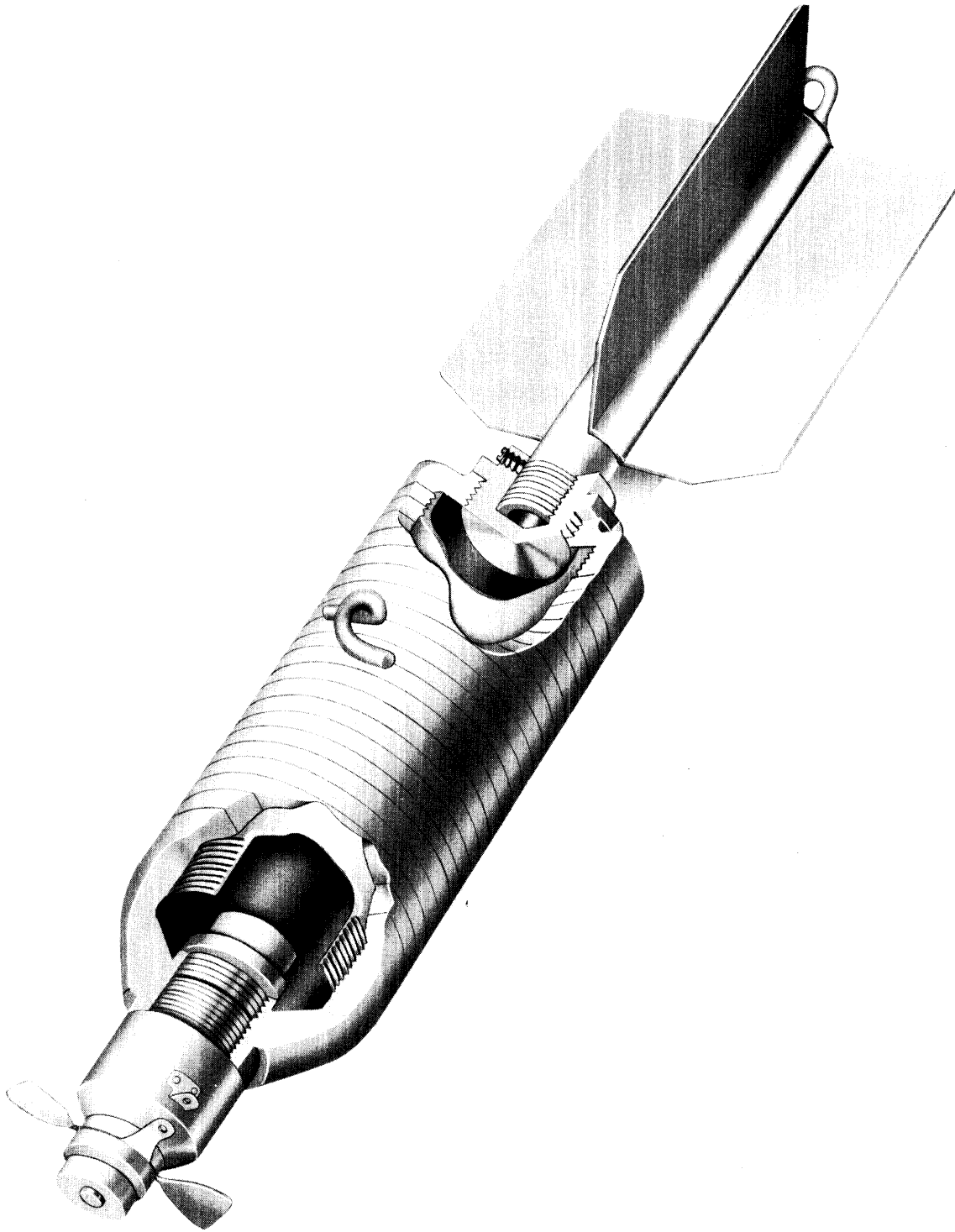

Figure 6.6—20-lb Fragmentation Bomb AN-M41A1, Cutaway View.

Section 6.4—90-lb Fragmentation Bomb M82

Description

The 90-lb Fragmentation Bomb M82, figure 6.7, is constructed of spirally wound wire. A seamless steel inner tube forms the base for the outer wound steel wire. A rounded nose piece houses the nose fuze, and a box-type fin assembly is attached to the tapered aft end by a fin locknut.

The M82 is designed for use in clusters and for single suspension. It has only one suspension lug welded to its casing. When adapted for single suspension, instantaneous or VT fuzes are used. The fitting of a mechanical-time fuze is permitted with the addition of an adapter-booster.

Approximately 12 percent of the complete weight of Fragmentation Bomb M82 consists of Composition B or TNT. Yellow bands on the nose and aft end of the bomb body identify the high-explosive charge. Identifying nomenclature is stenciled in black on the olive-drab painted bomb casing.

Physical Characteristics

- Weight of assembled fuzed bomb:
 - Loaded with Comp B..... 86.6 lbs
 - Loaded with TNT..... 87.4 lbs
- Weight of explosive:
 - Comp B..... 12.3 lbs
 - TNT..... 11.4 lbs
- Weight of fin:
 - Box Fin Assembly M101.... 2.46 lbs
- Dimensions:
 - Length or height of complete bomb..... 28.0 inches
 - Length of bomb body..... 20.0 inches
 - Diameter..... 6.06 inches
 - Fin span..... 8.11 inches
 - Fin length..... 9.25 inches
- Suspension:
 - Single suspension lug..... Center of gravity.

Components of a Complete Round (Figures 6.8 and 6.9)

- Bomb body assembly (including):
 - Bomb body
 - Fin locknut
 - Closing plugs

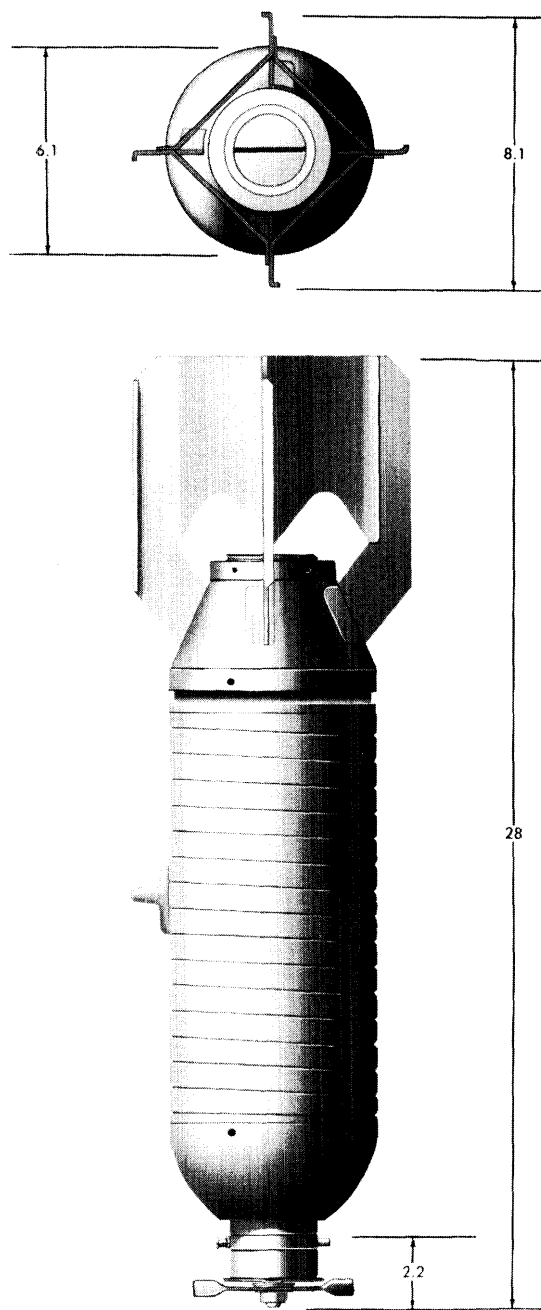

Figure 6.7—90-lb Fragmentation Bomb M82.

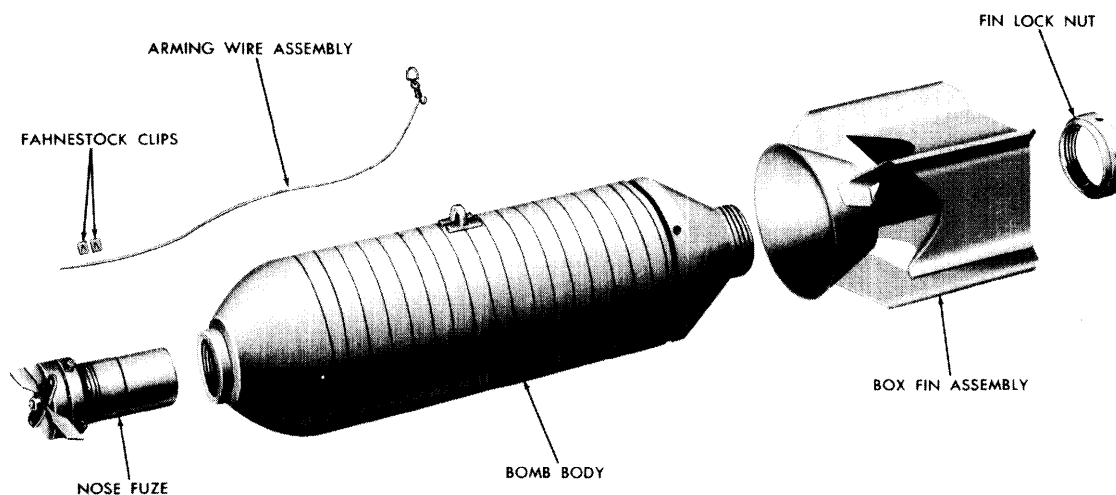

Figure 6.8—90-1b Fragmentation Bomb M82, Exploded View.

Box Fin Assembly M101

Nose fuze (one of):

AN-M103A (Use short vane)

VT Fuze AN-M166

VT Fuze AN-M168

AN-M145 (Use Adapter-booster M117)

Arming Wire Assembly Mk 1

Fahnestock clips

Assembly

CAUTION: Fuzes and bombs shall not be unpacked in advance of requirements. If unpacked and not used, return them to their original packings.

1. Remove shipping bands from bomb by removing nut from securing bolts. Remove closing plug from nose end.

CAUTION: Inspect for damage (cracks, broken weldment, etc.) which might weaken lug or its attachment to the bomb body.

2. Cut the shipping wire, and remove fin locknut and its protector. Remove protector from locknut.

3. Remove fin assembly and attachments from shipping crate. Position fin to clear aircraft structure and ground, when installed. Replace fin locknut and tighten with wrench.

CAUTION: Do not use fin assembly

if it cannot be secured to the bomb properly.

4. Install bomb in accordance with type of rack in use, and securely lock in place. If bomb bay does not provide enough space for fuzing, fuzing shall be done prior to hoisting bomb into place on the rack.

5. Remove required fuze and arming wire assembly from their containers.

CAUTION: If containers are punctured, split, or if the seal is broken in any way, the fuzes contained therein shall be considered unserviceable. This does not apply to fuzes repacked in the field and resealed with adhesive tape for temporary protection. These fuzes should be examined carefully for serviceability. All fuzes should have their safety devices (cotter, shear, and arming pins) in place. If any safety device is missing, handle the fuze with extreme care. Return the fuze to its container, and mark the container for disposal by authorized personnel.

6. For detailed information on fuzing and defuzing, refer to OP 988 (First Revision).

CAUTION: Never attempt to reservice mechanical-time Fuze AN-M145. Fuze AN-M145 is considered armed when one of the following conditions

exists: absence of the safety block; complete or partial ejection of the firing pin; or failure of the trigger arm

assembly to support the striker and prevent it from snapping down tightly against the safety block.

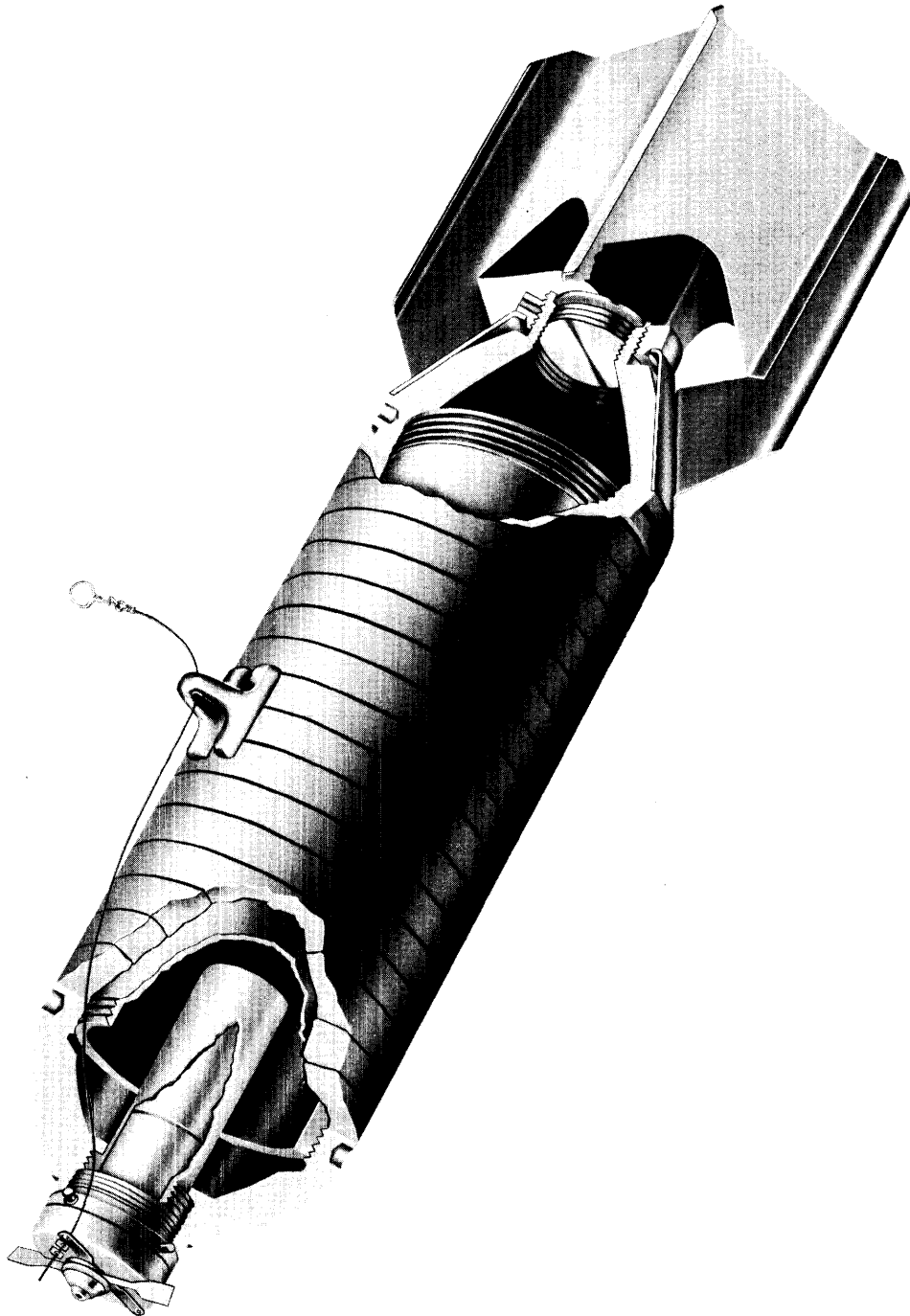

Figure 6.9—90-lb Fragmentation Bomb M82, Cutaway View.

Section 6.5—220-lb Fragmentation Bomb AN-M88 with Fin Assembly AN-M103A1

Description

The 220-lb Fragmentation Bomb AN-M88, figure 6.10, has a body constructed of spirally wound 13/16-inch square steel wire. A seamless steel tube forms the base for the outer wrapping. The steel wire winding is forged at the nose and tail to form solid nose and tail sections. A box-type fin (AN-M103A1) is secured to the aft end by a fin locknut. The nose and tail sections are threaded to accommodate nose and tail fuzes.

Approximately 19 percent of the complete weight of Fragmentation Bomb AN-M88 is explosive charge. Yellow bands on the nose and aft end of the bomb body identify the high-explosive filler as Composition B or TNT. Identifying nomenclature is stenciled in black on the olive-drab bomb casing.

Two suspension lugs are welded 14 inches apart on one side of the bomb body, and a single suspension lug is attached to the opposite side.

An earlier modification of the AN-M88 is Fragmentation Bomb AN-M81 which is heavier in weight because of its thicker wire windings. For detailed information on the AN-M81 with box or conical fin assemblies, refer to section 6.7 and section 6.8.

Physical Characteristics of Fragmentation Bomb AN-M88 with Fin Assembly AN-M103A1

Weight of assembled fuzed bomb:	
Loaded with Comp B	216.17 lbs
Loaded with TNT	217.7 lbs
Weight of explosive:	
Comp B	41.4 lbs
TNT	41.2 lbs
Weight of fin:	
Box Fin Assembly AN-M103A1	4.1 lbs
Dimensions:	
Length or height of complete bomb	43.7 inches
Length of bomb body	33.5 inches
Diameter	8.13 inches
Fin span	11.0 inches
Fin length	11.0 inches

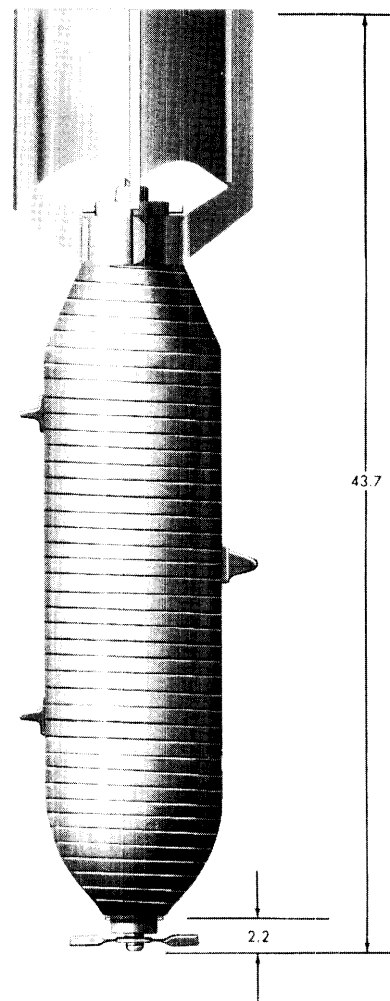
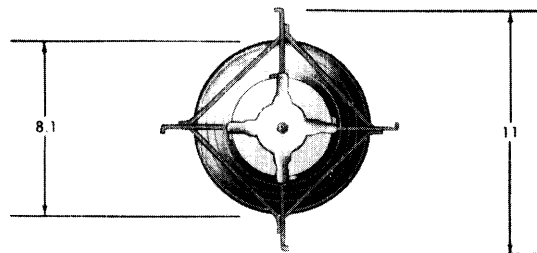

Figure 6.10—220-lb Fragmentation Bomb AN-M88 with Fin Assembly AN-M103A1.

Suspension:

- Two suspension lugs..... 14 inches c to c
- Single suspension lug..... Center of gravity

Components of a Complete Round (Figures 6.11 and 6.12)

Bomb body assembly (including):

- Bomb body
- Fin locknut (or Fin Lock Nut M1)
- Closing plugs

Box Fin Assembly AN-M103A1

Nose fuzes (one of):

- AN-M103A1
- AN-M145 (Use Adapter-booster M117)
- VT Fuze AN-M166
- VT Fuze AN-M168

Tail fuze:

- AN-M100A2 (with Primer-detonator M14, non-delay)
- Arming Wire Assembly Mk 2
- Fahnestock clips

Assembly

CAUTION: Fuzes and bombs shall not be unpacked in advance of require-

ments. When unpacked and not used, fuzes shall be returned to their original packings.

1. Remove shipping bands from bomb by removing nuts from securing bolts.

CAUTION: Inspect for damage (cracks, broken weldments, etc.) which might weaken lugs or their attachment to the bomb body.

2. Cut the shipping wire, and remove fin locknut and its protector. Remove protector from locknut.

3. Remove fin assembly and attachments from shipping crate. Position fin to clear aircraft structure and ground, when installed. Replace fin locknut and tighten with wrench. If bomb is to be carried at speeds in excess of 350 knots, use Fin Lock Nut M1 in place of the regular fin locknut.

CAUTION: Do not use fin assembly if it cannot be secured to the bomb body properly.

4. Install bomb on aircraft and securely lock in place. If bomb bay does not provide enough space for fuzing, fuzing shall be done prior to hoisting bomb into place on the rack.

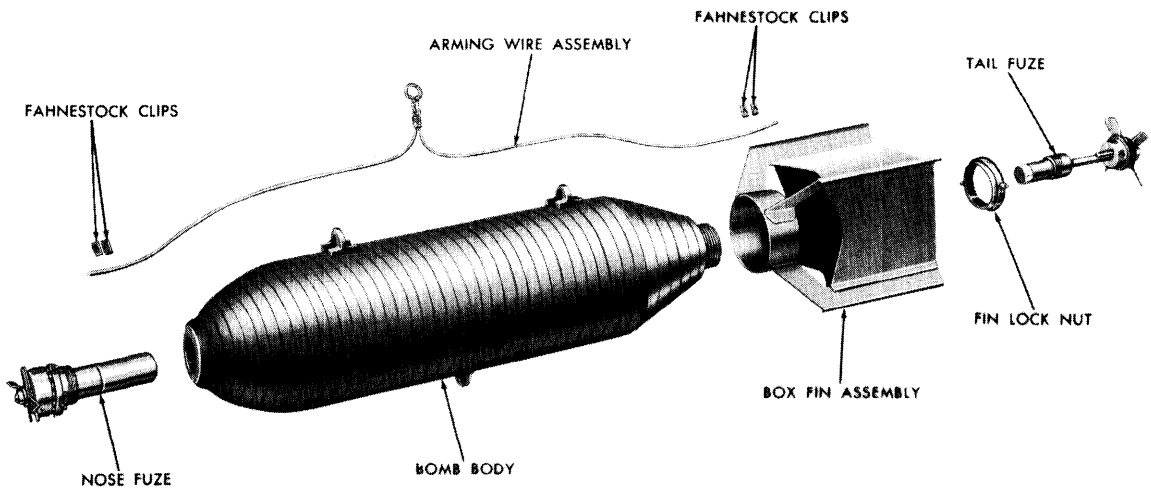

Figure 6.11—220-lb Fragmentation Bomb AN-M88 with Fin Assembly AN-M103A1, Exploded View.

5. Remove required fuze and arming wire assembly from their containers.

CAUTION: If containers are punctured, split, or if the seal is broken in any way, the fuzes contained therein shall be considered unserviceable. This does not apply to fuzes repacked in the field and resealed with adhesive tape for temporary protection. These fuzes should be examined carefully for serviceability.

6. For detailed information on fuzing and defuzing, refer to OP 988 (First Revision).

CAUTION: Never attempt to reserve mechanical-time Nose Fuze AN-M145. Nose Fuze AN-M145 is considered armed when one of the following conditions exists: absence of the safety block; complete or partial ejection of the firing pin; or failure of the trigger arm assembly to support the striker and prevent it from snapping down tightly against the safety block.

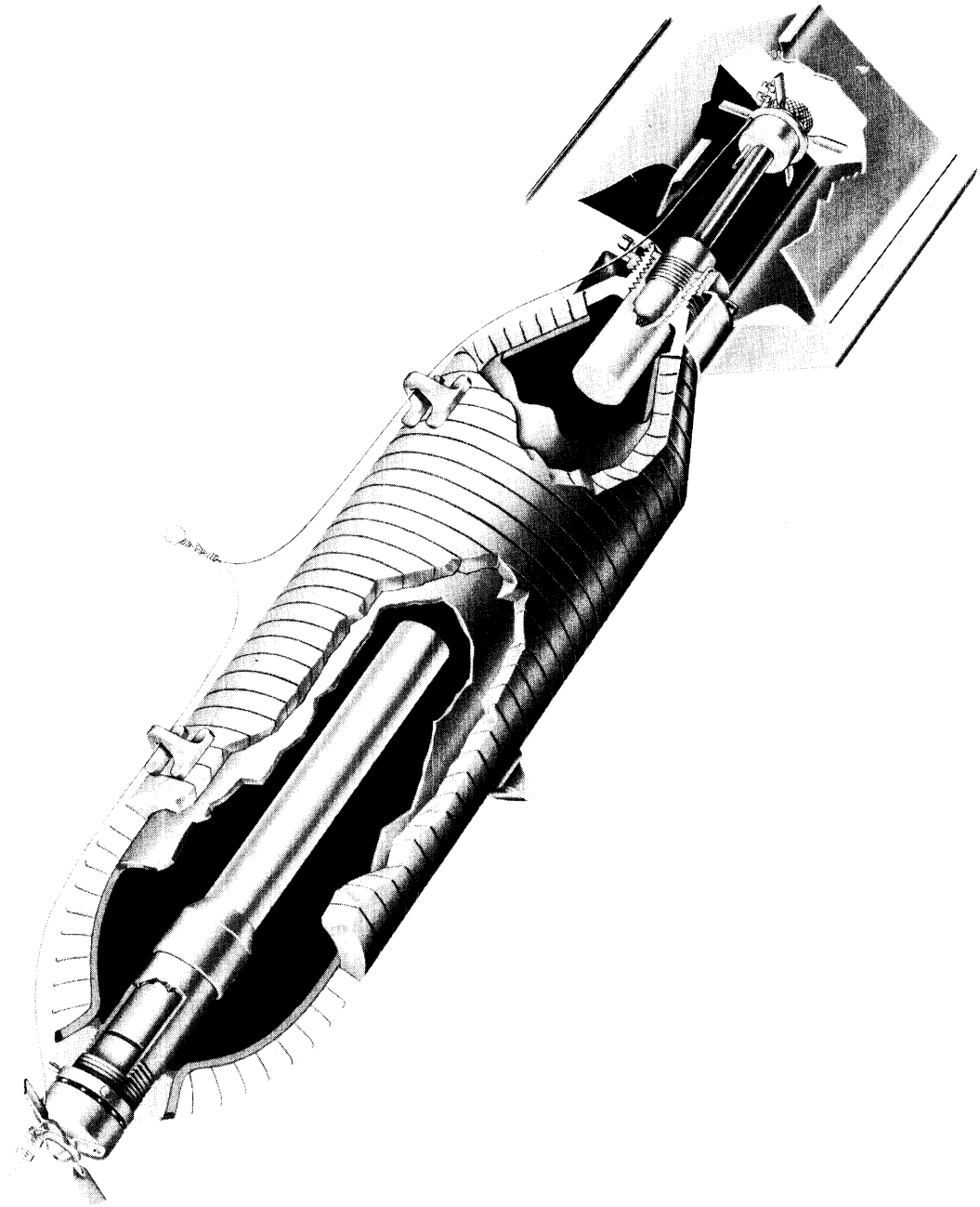

Figure 6.12—220-lb Fragmentation Bomb AN-M88 with Fin Assembly AN-M103A1, Cutaway View.

Section 6.6—220-lb Fragmentation Bomb AN-M88 with Fin Assembly M135

Description

The 220-lb Fragmentation Bomb AN-M88, equipped with Conical Fin Assembly M135, uses the standard Bomb Body AN-M88. The elongated conical fin assembly lengthens and streamlines Bomb AN-M88, improving its aerodynamic performance and accuracy in bombing. Conical Fin Assembly M135 consists of an elongated cone with four integral blades spaced at equal distances on the cone. A support tube runs through the center of the cone and the fin assembly is secured to the bomb body by means of this support tube, a locking web, and a locknut. Installation of Conical Fin Assembly M135 requires the use of one of the new long-stem tail fuzes to locate the arming vane effectively in the airstream.

Yellow bands on the nose and aft sections of the body identify the high-explosive contents of the bomb which consists of Composition B or TNT. Identifying nomenclature is stenciled in black on the olive-drab bomb casing.

Physical Characteristics

Weight of assembled
fuzed bomb:

- Loaded with Comp B_ 229.5 lbs
- Loaded with TNT_ 231.0 lbs

Weight of explosive:

- Comp B_ 41.4 lbs
- TNT_ 41.2 lbs

Weight of fin:

- Conical Fin Assembly M135 17.5 lbs

Dimensions:

- Length or height of complete bomb 58.0 inches
- Length of bomb body_ 33.5 inches
- Diameter_ 8.13 inches
- Fin span_ 11.19 inches
- Fin length_ 29.0 inches

Suspension:

- Two suspension lugs_ 14 inches c to c
- Single suspension lug_ Center of gravity

Components of a Complete Round (Figure 6.13)

Bomb body assembly (including):

- Bomb body
- Fin locknut (Supplied with bomb body; to be removed and discarded)
- Closing plugs

Conical Fin Assembly M135

- Fin Lock Nut (Dwg 1350522)
 - Fin Locking Web (BuOrd Sk 329153)
- } supplied separately.

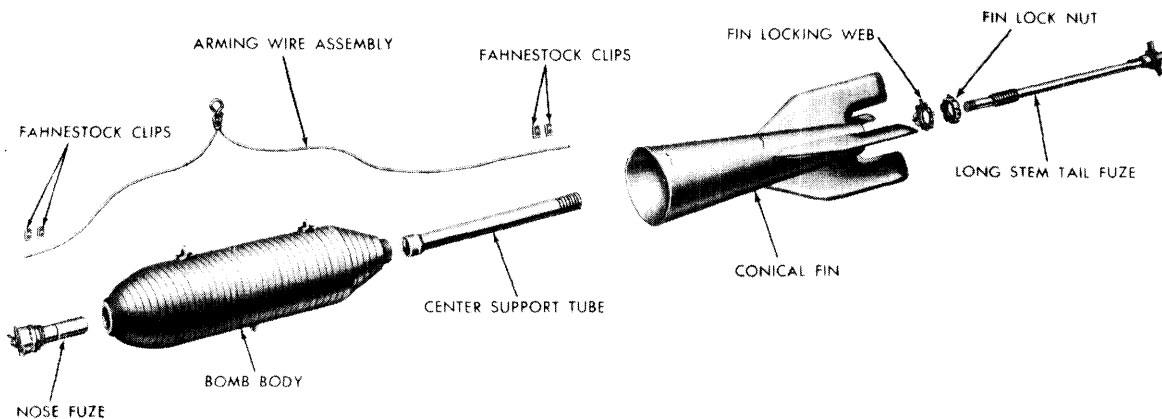

Figure 6.13—220-lb Fragmentation Bomb AN-M88 with Fin Assembly M135, Exploded View.

Nose fuzes (one of):
 AN-M103A1
 AN-M145 (Use Adapter-booster M117)
 VT Fuze M166
 VT Fuze M168
 Tail fuzes (one of):
 M172
 M175
 Arming Wire Assembly Mk 2
 Fahnestock clips

Assembly

CAUTION: Fuzes and bombs shall not be unpacked in advance of requirements. If unpacked and not used, return them to their original packings.

1. Remove shipping bands from bomb by removing nuts from securing bolts. Remove closing plugs.

CAUTION: Inspect for damage (cracks, broken weldments, etc.) which might weaken lugs or their attachment to the bomb body.

2. Cut the shipping wire. Remove and discard fin locknut and its protector.

3. Remove fin assembly and attachments from shipping crate. Thread center support tube onto base plug of bomb (locknut seat). Tighten tube with wrench. Tighten setscrews in support tube. Place fin cone over support tube. Slide cone back until jammed against

bomb body. Position fin assembly to clear aircraft structure and ground, when installed. Place fin locking web over support tube so that it engages blades of fin assembly. Secure conical fin assembly to support tube by threading on special locknut. (Discard locknut supplied with fin assembly.) Tighten locknut with special notched wrench. Bend two tabs of locking web into locknut slots. Secure nut in position by means of setscrews.

4. Install bomb on aircraft and securely lock in place. If bomb bay does not provide enough space for fuzing, fuzing shall be done prior to hoisting bomb into place on the rack.

5. Remove required number of fuzes and arming wire assemblies from their containers.

CAUTION: If containers are punctured, split, or if the seal is broken in any way, the fuzes contained therein shall be considered unserviceable. This does not apply to fuzes repacked in the field and resealed with adhesive tape for temporary protection. These fuzes shall be examined carefully for serviceability.

6. For detailed information on fuzing and defuzing, refer to OP 988 (First Revision).

CAUTION: Refer to OP 988 (First Revision) for handling precautions for the special long-stemmed fuzes. Do not remove safety cotter-pin locking arm mechanism from fuzes.

Section 6.7—260-lb Fragmentation Bomb AN-M81 with Fin Assembly AN-M103A1

Description

The 260-lb Fragmentation Bomb AN-M81, figure 6.14, has a body constructed of spirally wound 1-inch square wire. A seamless tube forms the base for the outer wrapping. The steel wire winding is forged at the nose and tail to form solid nose and tail sections. A box-type fin (AN-M103A1) is secured to the aft end by a fin locknut. The nose and tail sections are threaded to accommodate nose and tail fuzes.

Approximately 13 percent of the complete weight of Fragmentation Bomb AN-M81 is explosive filler. Yellow bands on the nose and aft end of the body identify the high-explosive filler of Composition B or TNT. Identifying nomenclature is stenciled in black on the olive-drab bomb casing. Two suspension lugs are welded 14 inches apart on one side of the bomb body, and a single lug is welded on the opposite side.

A later modification of Fragmentation Bomb AN-M81 is Fragmentation Bomb AN-M88 which is lighter in weight because of its thinner steel wire windings. For detailed information on Fragmentation Bomb AN-M88, refer to section 6.5 and section 6.6.

Physical Characteristics

- Weight of assembled fuzed bomb:
 - Loaded with Comp B . . . 263.0 lbs
 - Loaded with TNT 261.5 lbs
- Weight of explosive:
 - Comp B 36.0 lbs
 - TNT 34.5 lbs
- Weight of fin:
 - Box Fin Assembly 4.1 lbs
 - AN-M103A1
- Dimensions:
 - Length or height of 43.7 inches
 - complete bomb
 - Length of bomb body . . 33.5 inches
 - Diameter 8.13 inches
 - Fin span 11.0 inches
 - Fin length 11.0 inches
- Suspension:
 - Two suspension lugs . . . 14 inches c to c
 - Single suspension lug . . Center of gravity

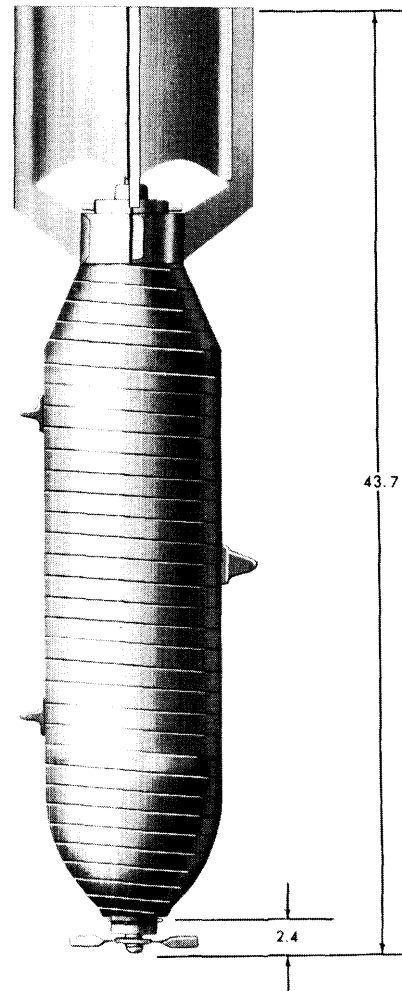
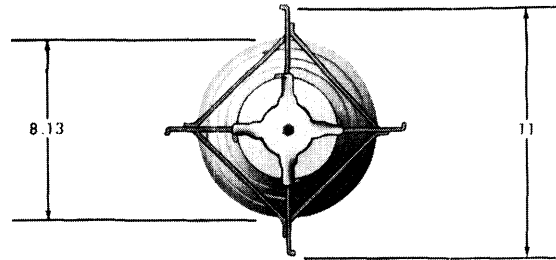

Figure 6.14—260-lb Fragmentation Bomb AN-M81 with Fin Assembly AN-M103A1.

Components of a Complete Round (Figures 6.15 and 6.16)

- Bomb body assembly (including):
 - Bomb body
 - Fin locknut (or Fin Lock Nut M1)
 - Closing plug
- Box Fin Assembly AN-M103A1
- Nose fuzes (one of):
 - AN-M103A1
 - AN-M145 (Use Adapter-booster M117)
 - VT Fuze AN-M166
 - VT Fuze AN-M168
- Tail fuze:
 - AN-M100A2 (with Primer-detonator M14, non-delay)
- Arming Wire Assembly, Mk 2
- Fahnestock clips

Assembly

CAUTION: Fuzes and bombs shall not be unpacked in advance of requirements. When unpacked and not used, fuzes shall be returned to their original packings.

1. Remove shipping bands from bomb by removing nuts from securing bolts.

CAUTION: Inspect for damage (cracks, broken weldments, etc.)

2. Cut the shipping wire, and remove fin locknut and its protector. Remove protector from locknut.
3. Remove fin assembly and attachments from shipping crate. Position fin so that it clears aircraft structure and ground, when installed. Replace fin locknut and tighten with wrench. If the bomb is to be carried externally at speeds in excess of 350 knots, use Fin Lock Nut M1 in place of the regular fin locknut.

CAUTION: Do not use fin assembly if it cannot be secured to the bomb body properly.

4. Install bomb on aircraft and securely lock in place. If bomb bay does not provide enough space for fuzing, fuzing shall be done prior to hoisting into bomb place on the rack.

5. Remove required fuzes and arming wire assemblies from their containers.

CAUTION: If containers are punctured, split, or if the seal is broken in any way, the fuzes contained therein shall be considered unserviceable. This does not apply to fuzes repacked in the field and resealed with adhesive tape for temporary protection. These

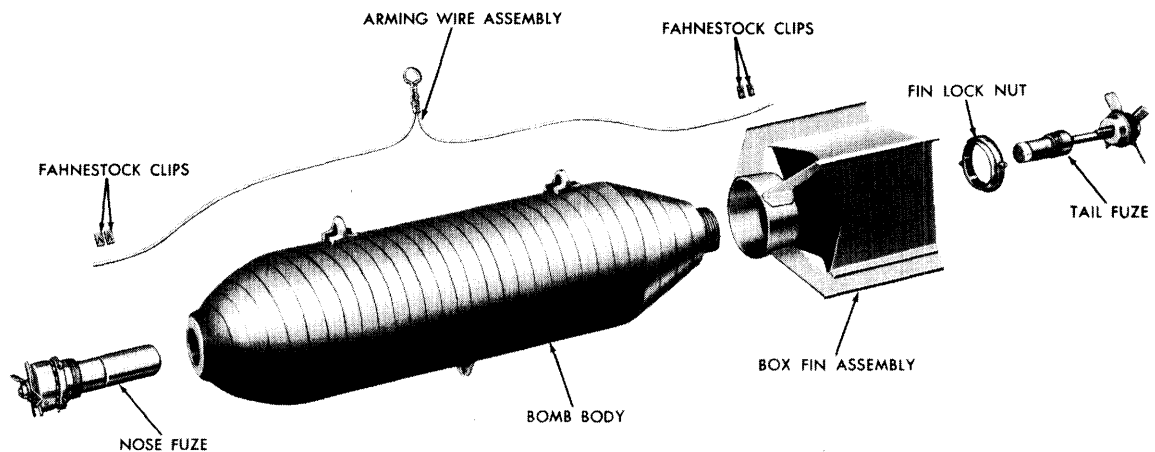

Figure 6.15—260-lb Fragmentation Bomb AN-M81 with Fin Assembly AN-M103A1, Exploded View.

fuzes should be examined carefully for serviceability.

6. For detailed information on fuzing and defuzing, refer to OP 988 (First Revision).

CAUTION: Never attempt to reserve mechanical-time Nose Fuze AN-M145. Nose Fuze AN-M145 is con-

sidered armed when one of the following conditions exist: absence of the safety block; complete or partial ejection of the firing pin; or failure of the trigger arm assembly to support the striker and prevent it from snapping down tightly against the safety block.

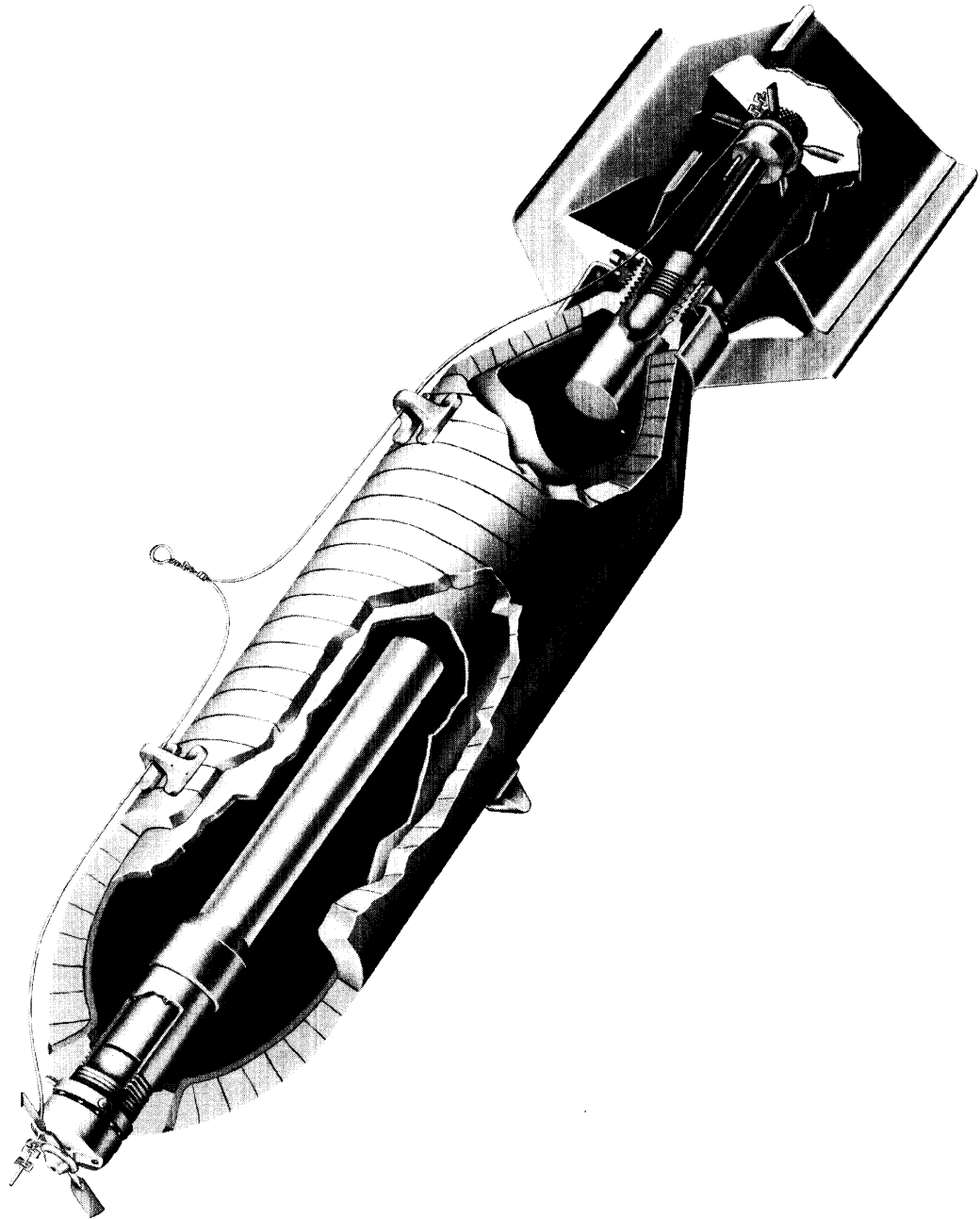

Figure 6.16—260-lb Fragmentation Bomb AN-M81 with Fin Assembly AN-M103A1, Cutaway View.

Section 6.8—260-lb Fragmentation Bomb AN-M81 with Fin Assembly M135

Description

The 260-lb Fragmentation Bomb M81, equipped with Conical Fin Assembly M135, uses the standard Bomb Body AN-M81. The elongated conical fin assembly lengthens and streamlines Bomb AN-M81, improving its aerodynamic performance and accuracy in bombing. Conical Fin Assembly M135 consists of an elongated cone with four integral blades spaced at equal distances on the fin cone. A support tube runs through the center of the cone, and the fin assembly is secured to the bomb body by means of this support tube, a locking web, and a locknut. Installation of Conical Fin Assembly M135 requires the use of one of the new long-stem tail fuzes to locate the arming vane effectively in the airstream.

Yellow bands on the nose and aft sections of the body identify the high-explosive filler of Composition B or TNT. Identifying nomenclature is stenciled in black on the olive-drab bomb casing.

Physical Characteristics of Fragmentation Bomb AN-M88 with Fin Assembly M135

Weight of assembled fuzed bomb:	
Loaded with Comp B	276.5 lbs
Loaded with TNT	275.0 lbs
Weight of explosive:	
Comp B	36.0 lbs
TNT	34.5 lbs
Weight of fin:	
Conical Fin Assembly M135	17.5 lbs
Dimensions:	
Length or height of complete bomb	43.7 inches
Length of bomb body	33.5 inches
Diameter	8.13 inches
Fin span	11.0 inches
Fin length	11.0 inches
Suspension:	
Two suspension lugs	14 inches c to c
Single suspension lug	Center of gravity

Components of a Complete Round (Figure 6.17)

- Bomb body assembly (including):
 - Bomb body
 - Fin locknut (Supplied with bomb body; to be removed and discarded)
 - Closing plugs
 - Conical Fin Assembly M135
 - Fin Lock Nut (Dwg 1350522)
 - Fin Locking Web (BuOrd Sk 329153)
- Nose fuze (one of):
 - AN-M103A1
 - AN-M145 (Use Adapter-boosters M117)
 - VT Fuze M166
 - VT Fuze M168
- Tail fuze (one of):
 - M172 (with Primer-detonator M14, non-delay)
 - M175 (with Primer-detonator M14, non-delay)
- Arming Wire Assembly Mk 2
- Fahnestock clips

Assembly

CAUTION: Fuzes and bombs shall not be unpacked in advance of requirements. When unpacked and not used, fuzes shall be returned to their original packings.

1. Remove shipping bands from bomb by removing nuts from securing bolts.

CAUTION: Inspect for damage (cracks, broken weldments, etc.) which might weaken lugs or their attachment to the bomb body.

2. Cut the shipping wire. Remove and discard fin locknut and its protector.
3. Remove fin assembly and attachments from shipping crate. Thread center support tube onto base plug of bomb (locknut seat). Tighten tube with wrench. Tighten setscrews in support tube. Place fin cone over support tube. Slide cone back until jammed against bomb body. Position fin assembly to clear air-

craft structure and ground, when installed. Place fin locking web over support tube so that it engages blades of fin assembly. Secure conical fin assembly to support tube by threading on special locknut. (Discard locknut supplied with fin assembly.) Tighten locknut with special notched wrench. Bend two tabs of locking web into locknut slots. Secure nut in position by means of setscrews.

4. Install bomb on aircraft and securely lock in place. If bomb bay does not provide enough space for fuzing, fuzing shall be done prior to hoisting bomb into place on the rack.

5. Remove required fuze and arming wire assembly from their containers.

CAUTION: If containers are punctured, split, or if the seal is broken in any way, the fuzes contained therein

shall be considered unserviceable. This does not apply to fuzes repacked in the field and resealed with adhesive tape for temporary protection. These fuzes should be examined carefully for serviceability.

6. For detailed information on fuzing and defuzing, refer to OP 988 (First Revision).

CAUTION: Never attempt to reservice mechanical-time Nose Fuze AN-M145. Nose Fuze AN-M145 is considered armed when one of the following conditions exists: absence of the safety block; complete or partial ejection of the firing pin; or failure of the trigger arm assembly to support the striker and prevent it from snapping down tightly against the safety block.

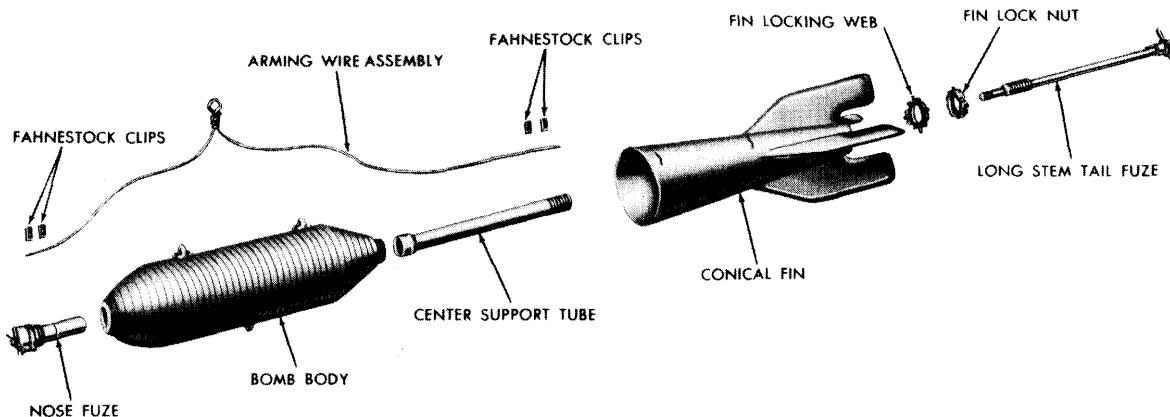

Figure 6.17—260-lb Fragmentation Bomb AN-M81 with Fin Assembly AN-M135, Exploded View

Chapter 7

FRAGMENTATION BOMB CLUSTERS

Section 7.1—General

Section 7.2—100-lb Fragmentation Bomb Cluster AN-M1A2

Section 7.3—100-lb Fragmentation Bomb Cluster M28A2

Section 7.4—500-lb Fragmentation Bomb Cluster M26A2 (M26A1)

Section 7.5—500-lb Fragmentation Bomb Cluster M27A1

Section 7.6—500-lb Fragmentation Bomb Cluster M29A1

Chapter 7

FRAGMENTATION BOMB CLUSTERS

Section 7.1—General

Description

A fragmentation bomb cluster is an assembly of several bombs, fuzes, and a cluster adapter. The cluster adapter holds several bombs as a unit in one carrying station.

The adapters may be of the “quick opening frame” type or of the “aimable” type.

A frame adapter, consisting of tubes and supports, holds several bombs in a compact group by means of bands. The assembly is suspended and released as a unit. Either an arming wire or shear wire holds release buckles in a closed position. For a “SAFE” release, the arming wire is dropped with the cluster preventing the clamps from opening and the fuze from arming. The individual bomb fuzes will not arm because they remain fixed to the cluster. For an “ARMED” release, the bombs are freed from the adapter by an arming wire or a time fuze. Premature arming of the individual bomb fuzes is prevented by arming vane stops or springs.

Aimable adapters are shaped approximately like conventional bombs. The small fragmentation bombs are contained in a hollow cylinder of the adapter. A flap of the adapter is opened in flight by a nose fuze, and the individual bombs spill out. A fin assembly is attached at the aft end for stabilization.

Usage

Fragmentation bomb clusters are dropped from aircraft for area bombing. More efficient coverage of a large target area is accomplished by dropping a cluster rather than individual bombs. Different blast patterns are achieved through the use of time fuzes to open the clusters.

Fragmentation Bomb Clusters

100-lb Fragmentation Bomb Cluster AN-M1A2

100-lb	Fragmentation	Bomb	Cluster
	M28A2		
500-lb	Fragmentation	Bomb	Cluster
	M26A2 and M26A1		
500-lb	Fragmentation	Bomb	Cluster
	M27A1		
500-lb	Fragmentation	Bomb	Cluster
	M29A1		

Fuzes Compatible with Fragmentation Bomb Clusters

The following fuzes are used with fragmentation bomb clusters.

- AN-M103A1 (for Fragmentation Bomb M82)
 - AN-M146 (cluster opening)
 - AN-M158 or AN-M110A1 (for Fragmentation Bomb AN-M41)
 - M155 (cluster opening)
 - M129
 - M130
 - M131
- } (for Fragmentation Bomb M83)

Markings

Fragmentation bomb clusters are identified by standard nomenclature which is stenciled in black on the cluster adapters. The adapters are painted olive-drab.

Yellow bands painted on the nose of the aimable adapters identify their high-explosive contents. The yellow heads and bases of the individual bombs contained in the frame adapters identify their high-explosive fillers.

Suspension

Each cluster adapter has two suspension lugs spaced 14 inches apart. A lug located at the center of gravity provides for single suspension.

Lugs on the frame adapters are on the upper bar. Two of the lugs of the aimable adapters protrude through the case lid. A single lug is secured to the outside of the lid with cap screws.

Safety Precautions

Bomb clusters present a special problem in care and handling. Special precautions should be taken by personnel handling the clusters.

Clusters usually are shipped individually in boxes, as assembled complete rounds. The installation of arming wire assemblies and fuzes completes the fragmentation bomb cluster for use. Safety devices are removed when the aircraft is ready for flight.

Safety Precautions To Be Observed

1. Fuzes, bombs, and clusters shall not be unpacked in advance of requirements. If unpacked and not used, return them to their original packings.

2. Packed clusters should be handled carefully. Carry and set boxed clusters in a horizontal position. Boxes should not be "walked" on their corners.

3. Any accidentally armed fuze, even if partially armed, must be handled only by authorized personnel.

4. Upon opening the box containing clusters, contents should be inspected to ensure that fuzes and safety devices are in place. For pin-type fuzes, the fuze safety wire and safety cotter pin should be in place. For vane-type fuzes, the safety block should be taped in place. If pin-type fuzes show evidence of being armed,

the cluster shall not be removed from the box; instead the box shall be taken with the utmost care to a safe place for destruction by authorized personnel.

5. If the safety blocks of vane-type fuzes have fallen out during shipment, they shall be replaced and taped in place. Then, the cluster shall be broken down, the disturbed fuzes removed from the bombs, and the fuzes destroyed by authorized personnel.

6. Bands which hold bombs in place should be tight and unbroken. Broken bands may be replaced and then, the cluster may be used.

7. Guard fuzes against dropping or bumping at all times, to prevent premature detonation.

8. Screw fuzes into bombs, handtight; never use a tool for this operation, unless specifically authorized.

9. Handle and install arming vanes with care to prevent distortion of blades, and possible malfunction of both fuze and bomb.

10. Do not remove warning tags when fuze is installed in a bomb.

11. Never remove safety cotter pins or car seals from fuzes prematurely.

12. Replace all safety pins when defuzing a bomb.

13. Inspect arming wires for kinks, twists, or burrs. Such defects may cause a bomb cluster to malfunction.

Section 7.2—100-lb Fragmentation Bomb Cluster AN-M1A2

Description

The 100-lb Fragmentation Bomb Cluster AN-M1A2 consists of six, 20-lb Fragmentation Bombs AN-M41A1 assembled in Cluster Adapter AN-M1A3, figure 7.1. AN-M1A3 is a "quick opening frame" type adapter which holds the bombs in two banks of three bombs each. The adapter is a mechanical type which releases the bombs upon withdrawal of the arming wires.

The bomb cluster is issued with individual bombs assembled but unfuzed; fuzing is done before the cluster is installed in the aircraft. Nose Fuze AN-M158 or AN-M110A1 is used with Bomb AN-M41A1.

Cluster Adapter AN-M1A3 has four sheet-metal bomb supports that are spaced at intervals on two tubes. Three flat-steel suspension lugs and two side plates are attached to the upper tube. Two spring strips are fitted to the bottom tube. Fuze vane lock springs fit into a ferrule in front of the spring strips. Three lock springs pass through the front support and three through the third support. The fuze vane lock springs prevent rotation of the fuze arming vanes while the bombs are in the cluster.

Two metal straps hold the bombs in place against the adapter. The free ends of the straps are locked in place by a toggle strap clamp. The clamps are secured by the arming wire. When the cluster is released armed, the arming wire is pulled out; the strap clamp opens; and the bombs are freed from the adapter. The spring strip aids in forcing the bombs away from the adapter. Flat steel lugs located on the upper tube provide for one or two point suspension.

Identifying nomenclature is stenciled in black on the face of the forward support. The high-explosive contents are identified by the yellow head and base of each of the 20-lb Fragmentation Bombs AN-M41A1.

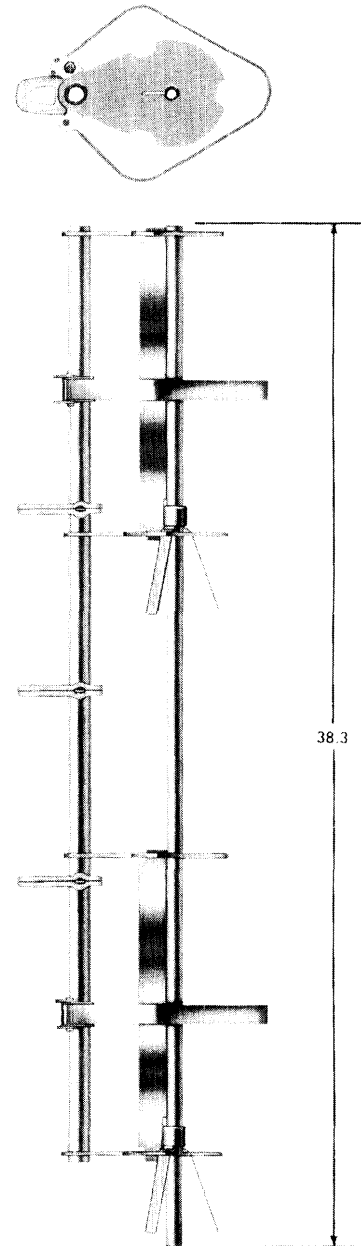

Figure 7.1—Cluster Adapter AN-M1A3.



Figure 7.2—100-lb Fragmentation Bomb Cluster AN-M1A2, Perspective View.

Differences Between Fragmentation Bomb Clusters AN-M1A2 and AN-M1A1 (Figure 7.2)

The differences between Fragmentation Bomb Cluster AN-M1A2 and Fragmentation Bomb Cluster AN-M1A1 are in the cluster adapters. Cluster AN-M1A2, figure 7.3, is the only cluster of this series that is issued unfuzed; Cluster Adapter AN-M1A3 was designed to permit this type of issue. Cluster AN-M1A1 uses Cluster Adapter M1A2 or M1A1 which has narrow U-type suspension lugs. These lugs decrease the complete weight of the cluster to 125 pounds.

Physical Characteristics of Fragmentation Bomb Cluster AN-M1A2

Weight of assembled fuzed fragmentation bomb cluster:

Loaded with 6 Fragmentation Bombs AN-M41A1 128.0 lbs

Weight of individual fragmentation bomb:
Fragmentation Bomb 20.2 lbs
AN-M41A1

Dimensions:

Length of complete fragmentation bomb cluster 36.6 inches

Length of empty cluster adapter 38.3 inches
Height of complete fragmentation bomb cluster 10.3 inches
Width of complete fragmentation bomb cluster 8.9 inches
Suspension:
Two suspension lugs..... 14 inches c to c
Single suspension lug..... Center of gravity

Components of a Complete Round

Cluster Adapter AN-M1A3
Fragmentation Bombs AN-M41A1 (6)
Nose fuze (for individual bombs) (one of):
AN-M110A1 (6)
AN-M158 (6)
Arming wire assembly

Assembly

CAUTION: Boxed fragmentation bomb clusters should be handled carefully. When set down, place in a horizontal position. Do not slide, tumble, or strike packings.

1. Unpack cluster and its components.
CAUTION: Upon opening the box, the cluster should be inspected to ensure that the fuze safety devices

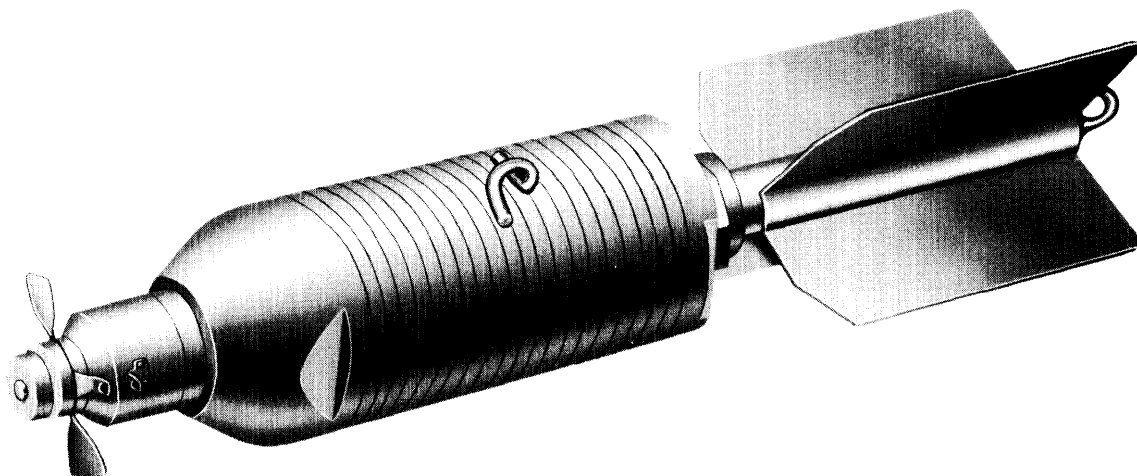

Figure 7.3—20-lb Fragmentation Bomb AN-M41A1.

are in place. If a fuze is armed, the cluster shall be destroyed by authorized personnel. Binding straps which hold the bombs in place should be tight and unbroken. Broken straps may be replaced and then, the cluster may be used.

2. Thread branch of arming wire through forward suspension lug and through the holes in the front release mechanism.

3. Thread the other branch of the arming wire through the rear lug and release mechanism.

4. Place two Fahnestock clips at each end of the arming wire; cut off excess wire.

CAUTION: Arming wire must be free from kinks, twists, and burrs.

5. Pull up suspension lugs and fasten with cotter pins supplied.

6. Assemble nose fuzes to Fragmentation Bombs AN-M41A1 according to the procedure outlined in OP 988 (First Revision).

7. Install cluster and remove cotter pins from release mechanism.

8. If the cluster is not used, replace all pins and tapes before repacking cluster for storage.

Section 7.3—100-lb Fragmentation Bomb Cluster M28A2

Description

The 100-lb Fragmentation Bomb Cluster M28A2, figure 7.4, consists of twenty-four, 4-lb Fragmentation Bombs M83 assembled in Cluster Adapter M15A2. M15A2, an aimable-type adapter, is bomb-like in appearance with a standard-type fin. It holds the fragmentation bombs in eight banks of three bombs each. This cluster is issued with the twenty-four Fragmentation Bombs M83 assembled in the cluster adapter.

Loading and dispersal of bombs is accomplished through a hinged lid on the adapter, which is held in place by a nose locking cup.

A spoiler ring is held in place against the nose of the adapter by the nose fuze, and a drag plate is secured to the fin assembly. Two suspension lugs, spaced 14 inches apart, protrude through slots in the lid section. If single hook suspension is desired, the two lugs are removed from the case and a single lug is attached by four screws to the upper bomb surface at the center of gravity.

When this cluster is released armed, the arming wire is withdrawn from the time fuze, allowing the fuze to arm. When the designated time has elapsed, the fuze functions, blowing the nose locking bushing rearward into the adapter case and permitting the cluster to open. The twenty-four Fragmentation Bombs M83 are dispersed when their wings open (by spring action) and project them into the air.

Identifying nomenclature is stenciled in black on the olive-drab painted adapter casing. The high-explosive content is indicated by yellow bands on the nose and aft section of the cluster adapter.

Differences Between Fragmentation Bomb Clusters M28, M28A1, and M28A2

These fragmentation bomb clusters are similar in appearance, differing only in their adapters.

Cluster M28 uses Cluster Adapter M15; M28A1 uses the M15A1 (with spoiler ring and drag plate); and M28A2 uses Cluster Adapter M15A2 (which contains a new nose locking bushing in addition to the spoiler ring and drag plate).

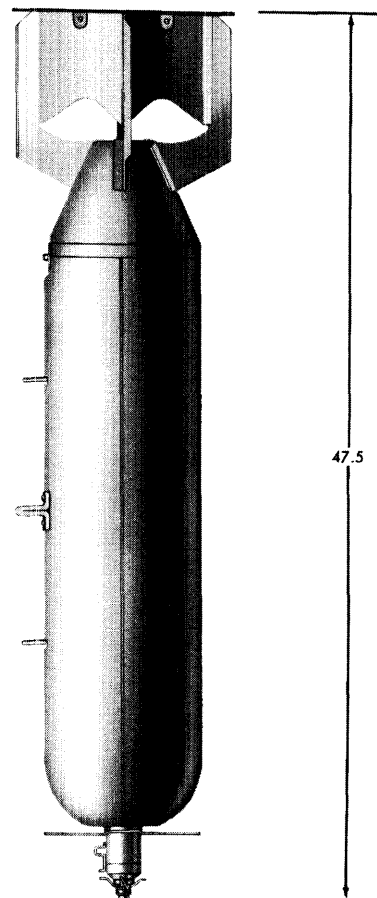
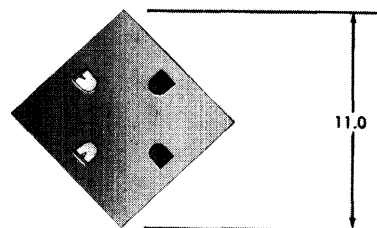

Figure 7.4—100-lb Fragmentation Bomb Cluster M28A2.

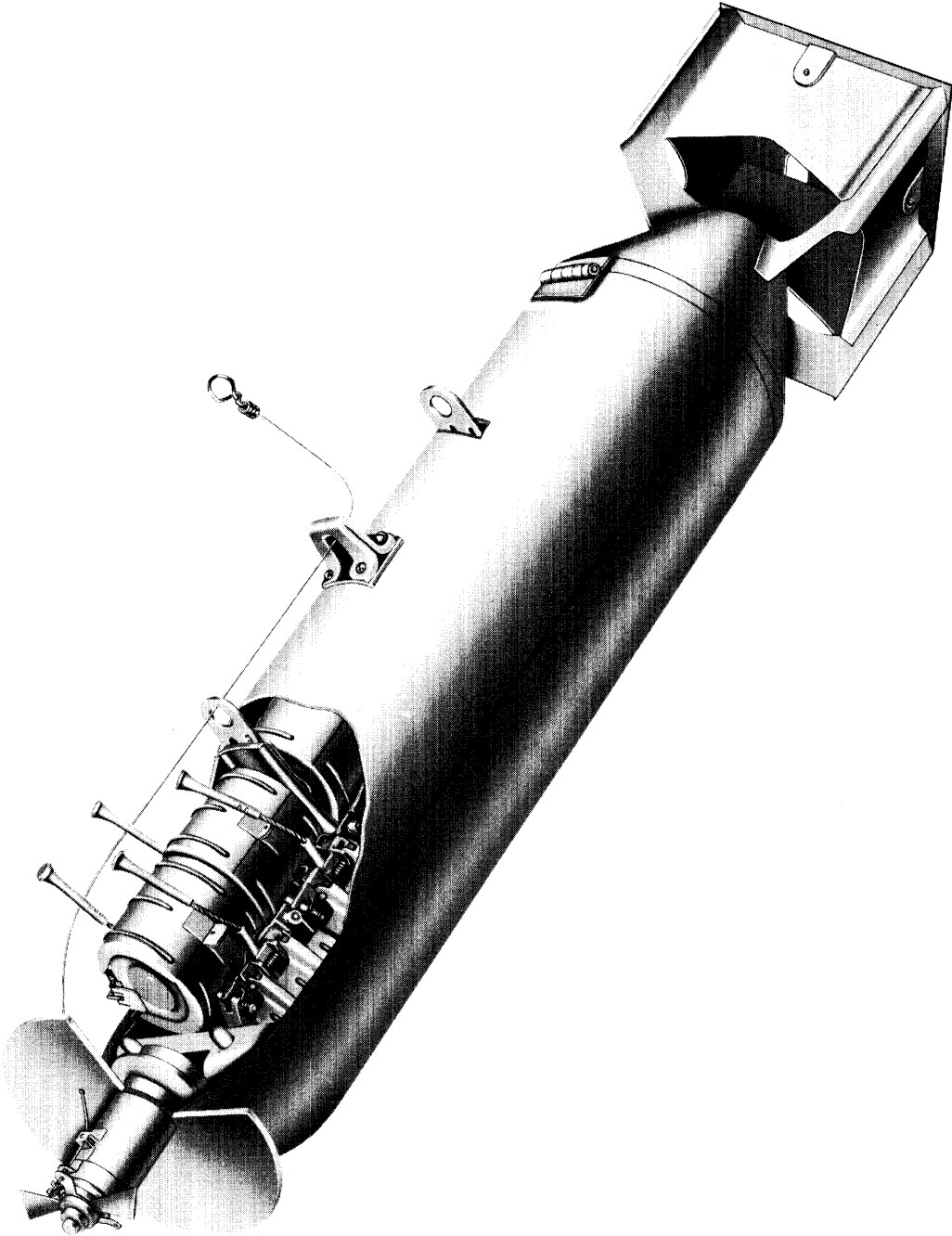

Figure 7.5—100-lb Fragmentation Bomb Cluster M28A2, Cutaway View.

Physical Characteristics of Fragmentation Bomb Cluster M28A2 (Figures 7.5 and 7.6)

Weight of assembled fuzeed cluster:	
Loaded with 24 Fragmentation Bombs M83	115.7 lbs
Weight of individual bomb:	
Fragmentation Bomb M83	4 lbs
Dimensions:	
Length or height of complete fragmentation bomb cluster	47.5 inches
Diameter	8.0 inches
Fin span	11.0 inches
Fin length	10.0 inches

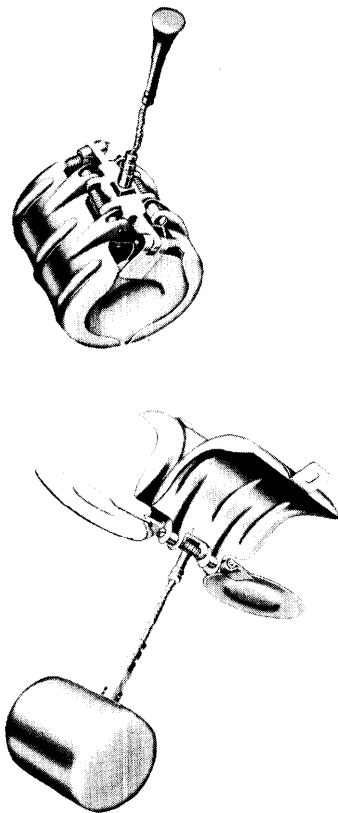

Figure 7.6—4-lb Fragmentation Bomb M83.

Suspension:

Two suspension lugs... 14 inches c to c
 Single suspension lug... Center of gravity

Components of a Complete Round

Cluster adapter assembly (including):

Cluster adapter
 Locking cup guard and wire
 Fragmentation Bomb M83 (24)
 Locking cup with securing screws
 Spoiler ring
 Drag plate with securing screws
 Suspension lugs with lock washers and screws
 Fuze (cluster opening):
 AN-M146
 Arming Wire Assembly Mk 1

Assembly

CAUTION: Do not disassemble cluster or any of its components.

1. Unpack cluster and its components. Cluster, as issued, contains 24 Fragmentation Bombs M83.

2. Support cluster in a horizontal position so that the tail fin is several inches above the ground.

3. Fit the drag plate over the tail fin so that one ear rests against the outside of each fin blade.

4. If holes are not drilled in the tail fin to accommodate the drag plate, drill holes with a No. 30 drill (0.128 inch in diameter). Use the holes in the drag-plate ears as guides.

5. Screw the drag plate to the fin with the self-tapping screws that are issued with the drag plate. Tighten screws securely.

6. Unthread the bolts and remove the L-shaped protectors from the suspension lugs. For single suspension, remove the double suspension lugs from the cases and attach the single lug to the bomb case with the screws provided.

7. Cut wire on nose cup retainer; remove wire and the retainer.

CAUTION: Locking cup screws must be tight before removing nose cup retainer.

8. Place the spoiler ring over the fuze cavity of the cluster adapter so that the flange of the spoiler ring hole fits inside the cavity.

9. While holding the spoiler ring in the position described in step 8, screw the fuze into the fuze cavity. Tighten fuze by hand, adjusting the spoiler ring at the same time; in its final position, the spoiler ring must be located so that the small hole in the ring is in line with the arming pin of the fuze. When installing

the arming wire, the wire must pass through the hole in the spoiler ring.

10. If the cluster is not used, restore components to their original condition and return them to their original packings.

CAUTION: Protect unpacked clusters from moisture.

Section 7.4—500-lb Fragmentation Bomb Cluster M26A2 (M26A1)

Description

The 500-lb Fragmentation Bomb Cluster M26A2 consists of twenty, 20-lb Fragmentation Bombs AN-M41A1 assembled in Cluster Adapter M13A2, figure 7.7. The M13A2 is a "quick opening frame" type adapter which holds the bombs in two banks of ten bombs each.

Adapter M13A2 may be set for immediate or delayed action release of bombs. For immediate release, a fuze is not required, because withdrawal of the arming wire opens the adapter. For delayed action, a mechanical-time fuze is inserted in the adapter. The fuze is set to function after a specified time delay following release of the cluster from the aircraft. Fuze detonation drives a plug rearward, cutting the shear wires, and opening the adapter.

Cluster Adapter M13A2 is a steel framework consisting of a tubular center bar, suspension lugs, separator plates, and two metal bands. Each separator plate fits in front of a bank of bombs and contains arming vane stops.

Two suspension lugs, spaced 14 inches apart, provide for two-point suspension. A lug located at the center of gravity provides for single-point suspension.

Identifying nomenclature is stenciled in black letters on the face of the first support plate. The overall frame is olive drab in color. The high-explosive content of the 20-lb Fragmentation Bomb AN-M41A1 is identified by a yellow head and base.

Differences Between Fragmentation Bomb Clusters M26A2 and M26A1 (Figures 7.8 and 7.9)

Fragmentation Bomb Cluster M26A2 differs from Fragmentation Bomb Cluster M26A1 in the adapters and fragmentation bombs used, and in the fuzing components. Fragmentation Cluster M26A1 is issued with 20 fuzed Fragmentation Bombs AN-M41 assembled in Cluster Adapter M13A1. Fragmentation Bomb Cluster M26A2 is issued with 20 unfuzed Fragmentation Bombs AN-M41A1 assembled in Cluster Adapter M13A2.

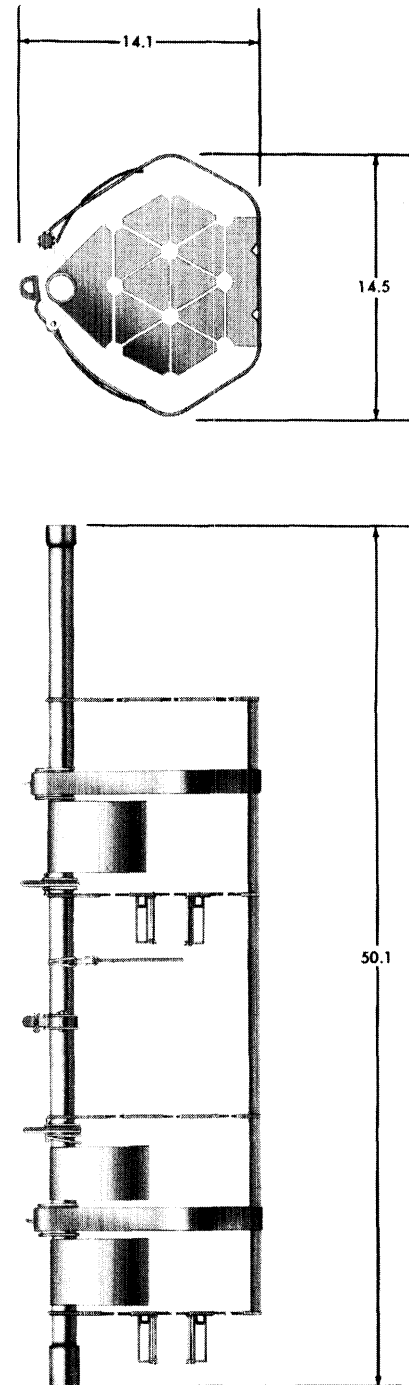

Figure 7.7—Cluster Adapter AN-M13A2.

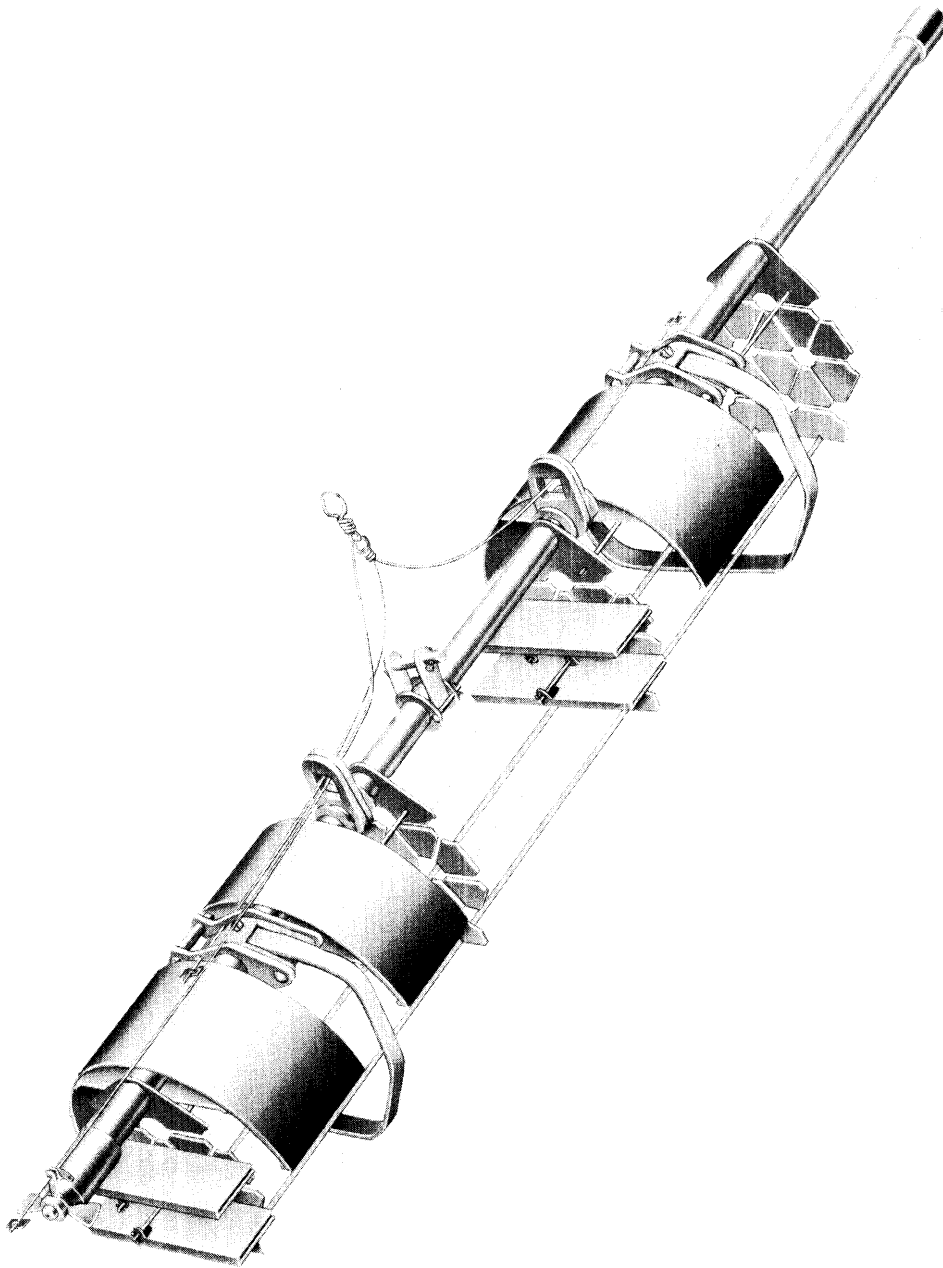

Figure 7.8—500-lb Fragmentation Bomb Cluster M26A2, Perspective View.

Physical Characteristics of Fragmentation Bomb Cluster M26A2

Weight of assembled fuzeed bomb cluster:

Loaded with 20 Frag- 416.0 lbs
mentation Bombs
AN-M41A1

Weight of individual bomb:

Fragmentation Bomb 20.2 lbs
AN-M41A1

Dimensions:

Length of complete 52.56 inches
fragmentation bomb
cluster

Suspension:

Two suspension lugs . . . 14 inches c to c
Single suspension lug . . . Center of gravity

Components of a Complete Round

Cluster Adapter M13A2

Fragmentation Bomb AN-M41A1 (20)

Nose fuze (for individual bombs) (one of):

AN-M158

AN-M110A1

Nose fuze for cluster adapter:

M155

Arming wire assembly

Assembly

1. Unpack cluster and remove all packing accessories.

CAUTION: Inspect cluster for serviceability. Be sure that cotter pins and shear wires are secure in band clamps. Bands which hold the bombs in place should be tight and unbroken.

2. Cut and remove wire holding removable fuze vane locks on the long separator assembly rods of cluster. Retain the two cotter pins which are threaded on the wire.

3. Unpack and inspect fuzes. Refer to OP 988 (First Revision) for instructions on fuzing.

4. Cut, but do not remove, fuze seal wires; hold wires in place by twisting wire.

5. Assemble fuzes to lower layer of rear bank of bombs. Adjust the arming wire guide on each fuze body so that it does not interfere with the assembly of the fuze vane lock.

6. Assemble fuzes to middle layer of bombs; adjust the arming wire guide of each fuze body so that it does not interfere with the assembly of the upper and lower fuze vane locks.

7. Replace lower fuze vane lock on rod, insert cotter pin, and spread cotter pin at least 90 degrees.

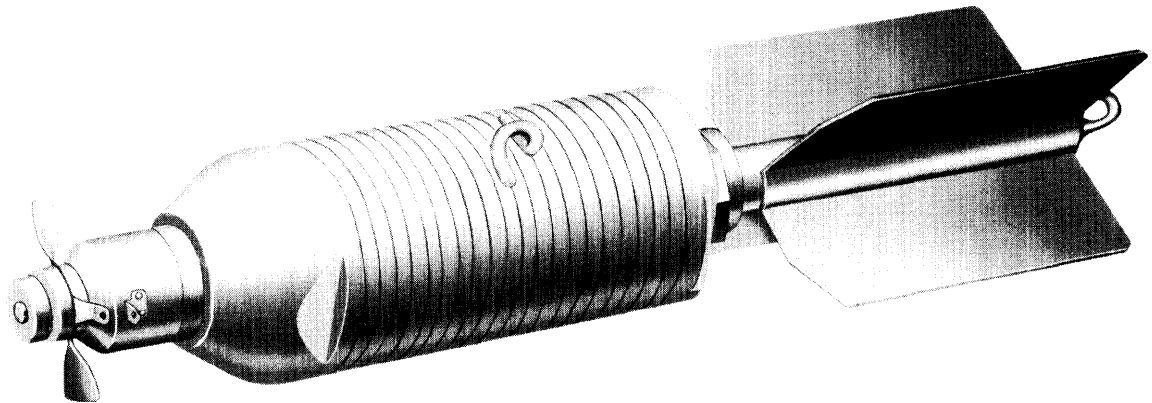

Figure 7.9—20-lb Fragmentation Bomb AN-M41A1.

8. Assemble fuzes to upper layer of bombs, replace upper fuze vane lock, insert cotter pin, and spread cotter pin at least 90 degrees.

9. Assemble fuzes and fuze vane locks to front bank of bombs in the same manner as previously described for rear bomb banks.

10. After vane locks are secured, remove fuze sealing wires.

Preparation of Bomb Cluster M26A2 for Immediate Opening

1. Cut off fine branch of arming wire.

2. Pass one branch of arming wire through forward suspension lug and through outer holes in forward band clamp. Pass other branch of arming wire through rear lug and rear strap clamp.

3. At each band clamp, cut shear wire between clamp and sleeve, and pull wire out from under side of tube.

4. Remove band clamps.

5. Install cluster on the aircraft.

Preparation of Bomb Cluster M26A2 for Delayed Opening

1. Inspect fuze well in center tube for serviceability. Clean if necessary. Inspect center tube for presence of steel plug and its holding wire.

2. Install bomb cluster securely to bomb rack.

3. Inspect Mechanical-time Fuze M155 for serviceability. Set fuze for time desired. Refer to OP 988 (First Revision) for detailed information on setting Mechanical-time Fuze M155.

4. Screw fuze into center tube, until handtight.

5. Pass fine branch of arming wire through front suspension lug and through holes in the mechanical-time fuze arming pin bracket and vane. Cut excess wire off so that it extends beyond fuze two to three inches. If the bomb is to be carried on external racks, or carried internally at speeds in excess of 300 knots, place one Fahnestock clip on the end of the wire.

6. Pass heavy branches of arming wire through suspension lugs and band straps.

CAUTION: Do not cut shear wire of each band clamp. Arming wires must be free from kinks, twists, and burrs.

7. Remove cotter pins from band clamps. Remove sealing wire, cotter pin, and striker stop from mechanical-time fuze.

Disassembly of Fragmentation Bomb Cluster M26A2

If the fragmentation bomb cluster is not used, replace sealing wire, cotter pin, and striker stop in the time fuze. Replace the cotter pins in cluster band clamps. Remove arming wire from time fuze, and remove time fuze for separate storage. Remove cluster from the bomb rack. For temporary storage (alerted ammunition) the cluster may be stored without unfuzing the individual bombs. For other than temporary storage, the individual bombs shall be unfuzed as follows:

1. Replace and secure seal wires in fuzes in top layer of bombs.

2. Remove upper fuze vane lock.

3. Replace and secure seal wires in fuzes in middle layer of bombs.

4. Remove fuzes from top layer of bombs, refer to OP 988 (First Revision) for procedures for removal of fuzes from bombs.

5. Replace and secure seal wires on fuzes in bottom layer of bombs.

6. Remove lower fuze vane lock.

7. Remove fuzes from center and bottom layers of bombs.

8. Repack and reseal fuzes in containers. Refer to OP 988 (First Revision) for detailed information on packing the specific fuzes used with Fragmentation Bomb Cluster M26A2.

9. Replace fuze well plugs and return the cluster to its original packing.

NOTE: If the cluster was prepared for immediate opening, new shear wires must be installed before cluster can be used for delayed opening.

Section 7.5—500-lb Fragmentation Bomb Cluster M27A1

Description

The 500-lb Fragmentation Bomb Cluster M27A1 consists of six, 90-lb Fragmentation Bombs M82 assembled in Cluster Adapter M14A1, figure 7.10. M14A1 is a "quick opening frame" type adapter which holds the bombs in two banks of three bombs each.

Adapter M14A1 may be set for immediate or delayed action release of bombs. For immediate release, a fuze is not required, because withdrawal of the arming wire opens the adapter. For delayed action, one or two mechanical-time fuzes are inserted in the adapter. The fuzes are set to function after a specified time delay following release of the cluster from the aircraft. Fuze detonation drives a plug rearward, cutting the shear wires and opening the adapter.

Adapter M14A1 consists of two steel tubes and four steel support plates. These plates form the support for the six Fragmentation Bombs M82. The lower tube is the backbone of the cluster, and the upper tube carries the suspension lugs, buckles, and the fuze adapters.

Fragmentation Bomb Cluster M27A1 is assembled in the field and its components may be supplied unassembled or partially assembled. Two lugs, spaced 14 inches apart, provide for two-point suspension. A lug located at the center of gravity provides for single suspension.

The adapter frame is olive drab in color, and nomenclature is stenciled in black. The high-explosive content of Fragmentation Bomb M82 is identified by yellow-painted heads and bases.

Differences Between Fragmentation Bomb Clusters M27A1 and M27

The difference between Fragmentation Bomb Cluster M27A1 and Fragmentation Bomb Cluster M27 lies in the cluster adapter. Bomb Cluster M27A1 uses Adapter M14A1 and Bomb Cluster M27 uses Adapter M14.

Adapter M14A1 is similar to Adapter M14 except that the M14 has wider fuze vane lock plates, reinforced sway brace plates, a leaf spring for the bottom bomb, and a 1½-inch wide release strap.

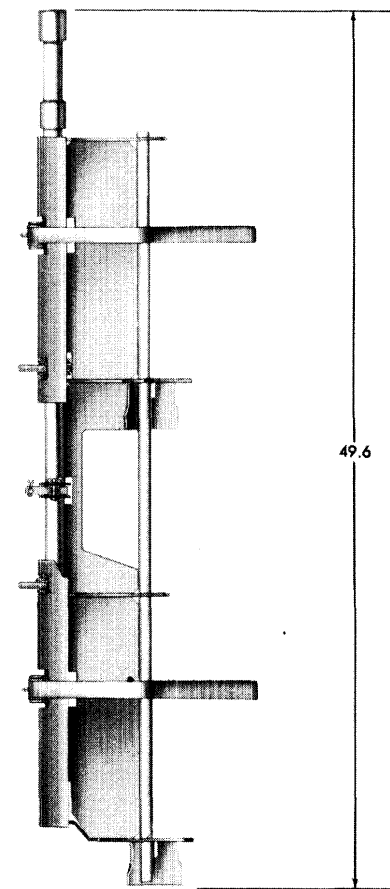
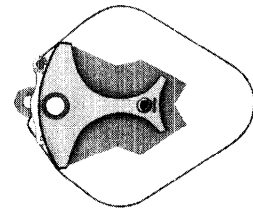

Figure 7.10—Cluster Adapter M14A1.



Figure 7.11—500-lb Fragmentation Bomb Cluster M27A1, Perspective View.

Physical Characteristics of Fragmentation Bomb Cluster M27A1

Weight of assembled fuze bomb cluster:

Loaded with 6 Frag- 585 lbs
mentation Bombs
M82

Weight of individual bomb:

Fragmentation Bomb 82.5 lbs
M82

Dimensions:

Length of complete 59 inches
fragmentation
bomb cluster

Length of empty 49.6 inches
cluster adapter

Suspension:

Two suspension lugs. 14 inches c to c
Single suspension Center of gravity
lug.

Components of a Complete Round (Figures 7.11 and 7.12)

Cluster Adapter M14A1

Fragmentation Bomb M82 (6)

Nose fuze (for individual bombs):

AN-M103A1

Nose fuze (for cluster adapter):

M155

Arming wire assemblies

Assembly

1. Remove bomb cluster from shipping bands.
2. Remove nose plugs and nose protector caps.
3. Release locknuts and remove connectors.
4. Remove fin locknuts from all bombs in the cluster.
5. Inspect fuze cavities and threads.
6. Assemble fin assemblies to bombs. Fins must not interfere with each other or damage each other when the cluster is assembled in the aircraft.
7. Unpack six Bomb Fuzes AN-M103A1. Inspect for serviceability. Discard the vane assembly supplied with the fuze.
8. Set each fuze for instantaneous action by pulling out the setting pin and turning it so that the locating pin seats in the shallow slot.
9. Screw a fuze handtight into the nose of

each bomb. Safety cotter pins must be accessible from the outside of the cluster.

10. Cut and remove the fuze seal wire. Assemble the short (4.6 inch) vane supplied with the fin assembly.

11. Remove the safety cotter pin and turn the vane each way to be sure that the adapter vane stop will prevent the fuze vane from rotating.

Preparation of Bomb Cluster M27A1 for Immediate Opening

To prepare bomb cluster for immediate opening upon release, prepare bombs as described in the preceding steps 1 through 11. Then proceed as follows:

1. Thread a heavy branch of arming wire through each suspension lug and through holes in each corresponding release mechanism. Place a Fahnstock clip on each branch of wire.

2. Cut off both branches of fine arming wire at swivel loop.

3. Cut the shear wire in each release mechanism close to the clamp.

4. Install the cluster securely on the aircraft and sway brace.

5. Remove safety cotter pins from both release mechanisms and from the six fuzes of Fragmentation Bombs M82.

6. If fragmentation bomb cluster is not used, replace all cotter pins and shear wires, or tie a conspicuous tag to the release mechanism to indicate that the shear wire has been cut, and the cluster is prepared for immediate opening only.

Preparation of Bomb Cluster M27A1 for Delayed Opening

To prepare bomb cluster for delayed opening, prepare bombs as outlined under Assembly, steps 1 through 11. Then proceed as follows:

1. Remove plug from nose fuze adapter in upper steel tube. Remove envelope containing setscrew. Inspect to see if cavity is clear.

2. Unpack Mechanical-time Nose Fuze M155, and inspect for serviceability. Remove and replace the striker stop to be sure that the safety block will not fall out. If trigger mechanism is intact, there will be a noticeable gap between the striker and the safety block.

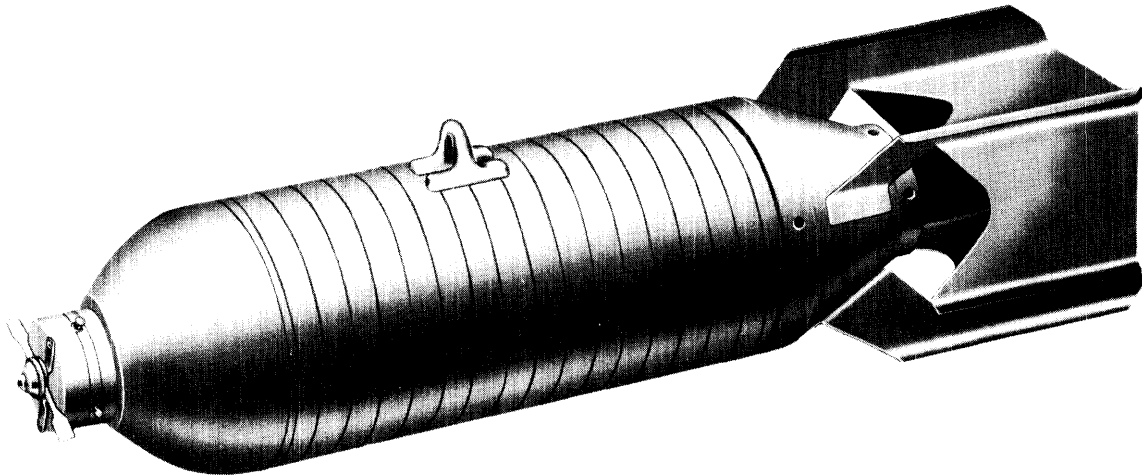

Figure 7.12—90-lb Fragmentation Bomb M82.

3. Set the time desired on the fuze. Refer to OP 988 (First Revision) for instructions for setting Nose Fuze M155.

4. Screw the fuze into the fuze adapter, handtight. Insert setscrew and locknut. Back off the fuze until the arming pin points up. Tighten setscrew and locknut.

5. Thread a heavy branch of arming wire through each suspension lug to the front and rear release buckles. Thread each wire through the empty hole in the release mechanism, and install a Fahnestock clip to the end of each wire.

6. Thread a fine branch of arming wire through each suspension lug to the two mechanical-time fuzes. If only one fuze is

used, cut off the rear branch of fine wire at the swivel loop. Pass the wire through the fuze arming pin, arming wire guide, and vane tab of each fuze so that the wire protrudes about 2.5 inches beyond the vane tab. If the cluster is to be carried externally, or if it is to be carried internally at speeds in excess of 300 knots, place a Fahnestock clip on each arming wire past the fuze vane tabs.

7. Cut and remove fuze sealing wire, safety cotter pin, and striker stop.

8. Install fragmentation bomb cluster securely on aircraft and sway brace.

9. Remove safety cotter pins from the cluster release mechanisms and from the six fuzes of the Fragmentation Bombs M82.

Section 7.6—500-lb Fragmentation Bomb Cluster M29A1

Description

The 500-lb Fragmentation Bomb Cluster M29A1, figure 7.13, consists of ninety, 4-lb Fragmentation Bombs M83 assembled in Cluster Adapter M16A1. M16A1, an aimable-type adapter, is bomb-like in appearance with a standard-type fin. The inside of the adapter body is partitioned for nine wafers. Each wafer consists of ten Fragmentation Bombs M83 strapped together. The bombs are assembled in the cluster in the field.

Loading and dispersal of bombs is accomplished through a hinged lid on the adapter which is held in its closed position by a nose locking cup.

When Fragmentation Bomb Cluster M29A1 is released armed, the arming wire is withdrawn from the time fuze, allowing the fuze to arm. When the time has elapsed, the fuze functions to blow the nose cup rearward into the adapter, permitting the cluster lid to open. The ninety Fragmentation Bombs M83 are dispersed when their wings open (by spring action) and project them into the air.

Two suspension lugs, spaced 14 inches apart, protrude through slots in the lid section. If single hook suspension is desired, a single lug can be attached with screws to a position above the center of gravity. Identifying nomenclature is stenciled in black on the bomb; the bomb cluster case is painted olive drab. Two one-inch yellow stripes indicate that Cluster M29A1 is loaded with high-explosives.

Differences Between Fragmentation Bomb Clusters M29 and M29A1

The difference between Fragmentation Bomb Cluster M29 and Fragmentation Bomb Cluster M29A1 is in the adapter. M29 uses Cluster Adapter M16 and M29A1 uses Cluster Adapter M16A1. The adapters differ in that the M16A1 contains a new-type locking cup.

Physical Characteristics

Weight of assembled fuzed bomb cluster:

Loaded with 90 Fragmentation Bombs M83	415.1 lbs
--	-----------

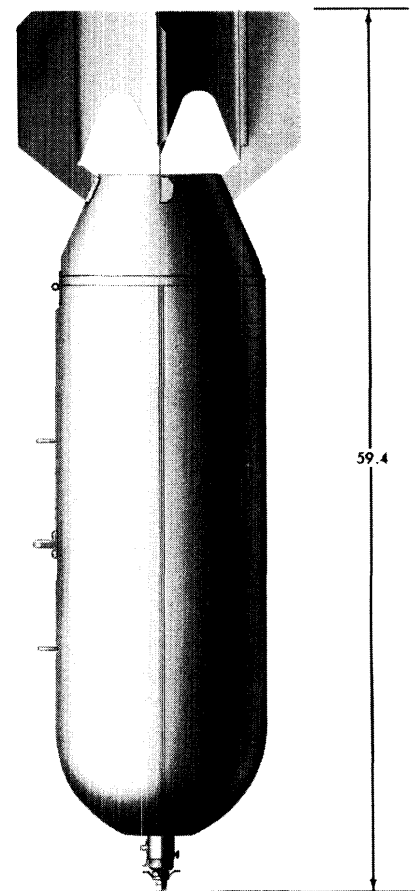
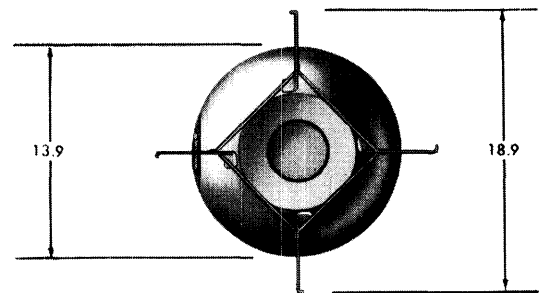

Figure 7.13—500-lb Fragmentation Bomb Cluster M29A1.

Weight of individual bomb:

Fragmentation Bomb 4 lbs
M83

Dimensions:

Length or height of 59.4 inches
complete fragmen-
tation bomb cluster

Diameter----- 13.9 inches

Fin span----- 18.9 inches

Fin length----- 14.0 inches

Suspension:

Two suspension lugs 14 inches c to c

Single suspension lug Center of gravity

Components of a Complete Round

Cluster Adapter Assembly M16A1 (in-
cluding):

Cluster adapter

Locking cup

Suspension lugs

Fragmentation Bombs M83 (90)

Fuze (cluster opening):

M155

Arming wire assembly

Assembly (Figures 7.14 and 7.15)

Bomb Cluster M29A1 components are shipped separately and are assembled in the field.

CAUTION: Follow assembly instructions carefully.

Preparing Adapter

1. Remove Cluster Adapter M16A1 from wooden crate and place on horizontal supports so that the tail fin is off the ground.

2. Unscrew and remove the suspension lug guards.

3. Cut shipping wire on cup container located in the nose of adapter.

4. Turn the screws of the locking cup in a counterclockwise direction forcing the locking cup inward. The cover of the adapter may be opened by prying with a screwdriver along the seam, a little way from the nose. For Adapter M16, drive back the locking cup by inserting a wooden stick or similar object into the nose fuze well and tapping inward to dislodge the cup.

5. Thread a cord through the hole in the pull piece of the locking cup, passing the free end through the nose fuze well opening. When the lid is closed, the cord may be used to pull the locking cup into place.

Loading Bombs Into Cluster

1. Open individually packed wafer boxes by tearing open the metal liner and removing the strapping which secures the wafers to the plywood inserts. Remove twine which is packed with wafers; save for later use.

2. Lift wafers by cable assemblies (pigtailed) and place four wafers in the two center bays of the bottom half of the adapter.

CAUTION: Do not handle wafers by the strappings.

3. If bomb cluster is to be suspended from a single suspension lug, remove the metal brace, single suspension lug, and screws from inside of the wooden case in which the adapter cluster is packed.

4. Remove the two regular suspension lugs of the adapter, and fasten the metal brace in place between the partitions using screws taken from the two regular suspension lugs.

5. Fasten the single suspension lug in place on the metal brace with the machine screws in the two sets of holes nearest the tail end of the adapter. (There are three sets of holes on the brace; the forward set is not used.)

6. Fasten the suspension lug over the center partition of the cluster adapter with the small portion of the lug forward (towards the nose of the adapter). The two regular suspension lugs remain in place.

7. Place two wafers in the front bay and three wafers in the rear bay.

Arranging Bombs in the Cluster

1. Tie all wafers down separately with the twine provided. Pass the twine over the bombs and around the outside of the bottom half of the adapter; tie securely.

2. Cut and remove metal strapping from the bombs leaving the twine to hold the bombs together. Settle the bombs into place by careful shifting of the wafers. No rigid part of a bomb must interfere with closing of the cluster lid.

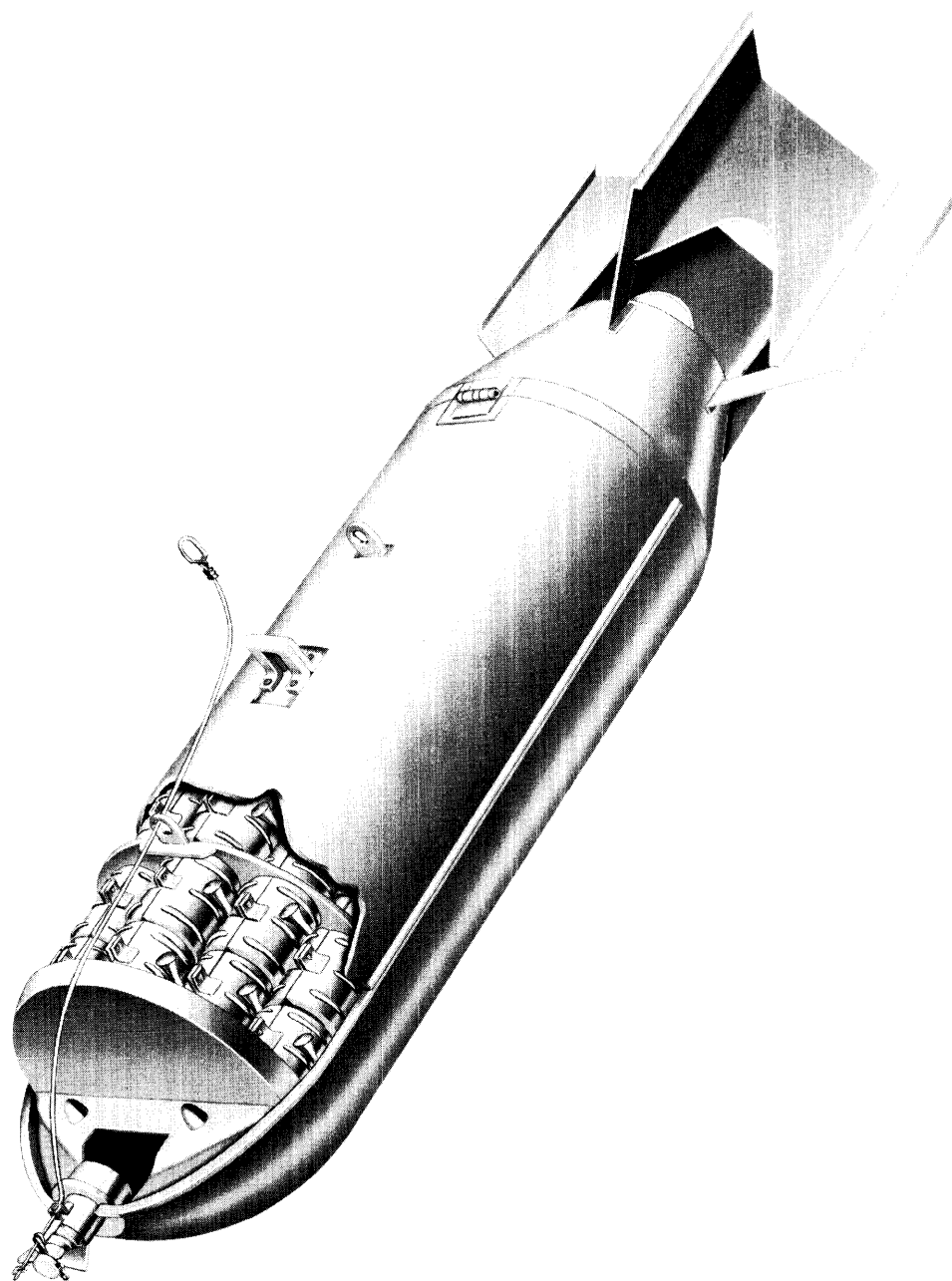

Figure 7.14—500-lb Fragmentation Bomb Cluster M29A1, Cutaway View.

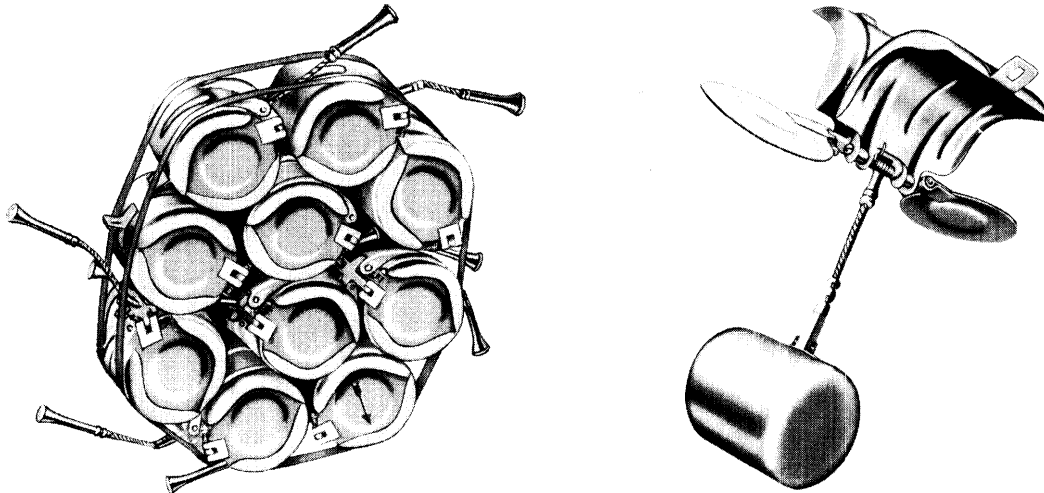

Figure 7.15—4-lb Fragmentation Bomb M83 and Wafer.

Closing the Cluster Adapter

1. Close the adapter by lowering the cover slowly; at the same time, adjust the cable assemblies of the bombs so that they do not rest across the partitions and do not obstruct the cover. When closing cover, the rear corners of the cover must be seated under the rear flange of the bottom half of the adapter, and the reinforcement strips on the edge of the cover must be inside the bottom half.

CAUTION: When the adapter is closed, its cover may cut some of the strings with which the wafers are tied. The cover must not be opened because the untied bombs will spring out.

2. When using Cluster Adapter M16 (Bomb Cluster M29), pull the locking cup into position with the string which previously was attached to it. Use the hook and prying tool provided to wedge the cup securely in its forward position. When using Adapter M16A1 (Bomb Cluster M29A1), pull the locking cup into position and turn the locking screws in a clockwise direction which will draw and hold the locking cup against the nose of the cluster.

3. Insert measuring gage (provided in kit) into fuze well of the adapter until it is against

the bottom surface of the locking cup. The maximum distance permissible between the nose of the cluster and the bottom surface of the locking cup is 1.375 inches. For Cluster M29, the minimum distance permissible is 0.8437 inch.

CAUTION: If adapters do not gage properly and cannot be adjusted, they should not be used.

4. With the cover securely in place and held by the locking cup, cut and remove the twine with which the wafers are tied. If twine does not pull out easily, the pieces may be cut on both sides of the adapter at the seam, and the upper portion may be left in the adapter.

5. Remove Mechanical-time Fuze M155 from its packing, and inspect for damage. For detailed information on unpacking and fuzing of Mechanical-time Fuze M155, refer to OP 988 (First Revision).

6. Install bomb securely on aircraft.

7. Pass one branch of the arming wire through the forward suspension lug, arming pin bracket, and vane of the fuze. Remove the fuze cotter pin and sealing wire. The arming wire should extend 2 to 3 inches beyond the fuze vane. If bomb is to be carried externally,

or internally at speeds in excess of 300 knots, place one Fahnestock clip on the end of the wire.

8. If Bomb Cluster M29A1 is not used, arming wire and time fuze shall be removed in accordance with instructions in OP 988 (First Revision).

CAUTION: Store loaded clusters off

the ground and under a paulin. Store for as short a period as possible, because this material is susceptible to damage by atmospheric moisture. Once loaded, the cluster adapter shall not be reopened. Locking cups must be in fully locked position before the time fuze is inserted.

CONFIDENTIAL

Chapter 8

DEMOLITION BOMBS

Section 8.1—General

Section 8.2—750-lb Demolition Bomb M117

Section 8.3—3000-lb Demolition Bomb M118

CONFIDENTIAL

157–158

Chapter 8

DEMOLITION BOMBS

Section 8.1—General

Description

Demolition bombs have a short ogival nose and a cylindrical body that tapers to the base, figure 8.1. An elongated conical-type fin assembly streamlines and lengthens these bombs. Their general appearance is similar to GP bombs equipped with conical fins.

These bombs have been designed primarily for electric fuzing. Both nose and tail fuze cavities are provided. Pending the availability of electric fuzing, adapter-boosters will be furnished to permit the use of mechanical fuzes. Adapter-boosters are not used with electric fuzes.

Demolition bombs are equipped with a steel nose plug. This plug is replaced when an electric fuze is installed in the fuze cavity. Bomb fin cones have covered hand holes for access to fuze tail positions. The tail fuze cavity cover is replaced when electric fuzes are used.

The nose and tail fuze cavities are connected to the outer surface of the bomb by two metal conduits which contain the electric fuze cable harness. When the cable harness is not used, a plug is threaded into the charging receptacle opening between the two suspension lugs. All seams and crevices in the bomb cavity are sealed with a sealer compound.

The explosive filler used in demolition bombs is Tritonal. This gives a blast effect which is greater than TNT or Composition B.

Usage

Demolition bombs are designed for a higher blast effect than general purpose bombs of comparable weights.

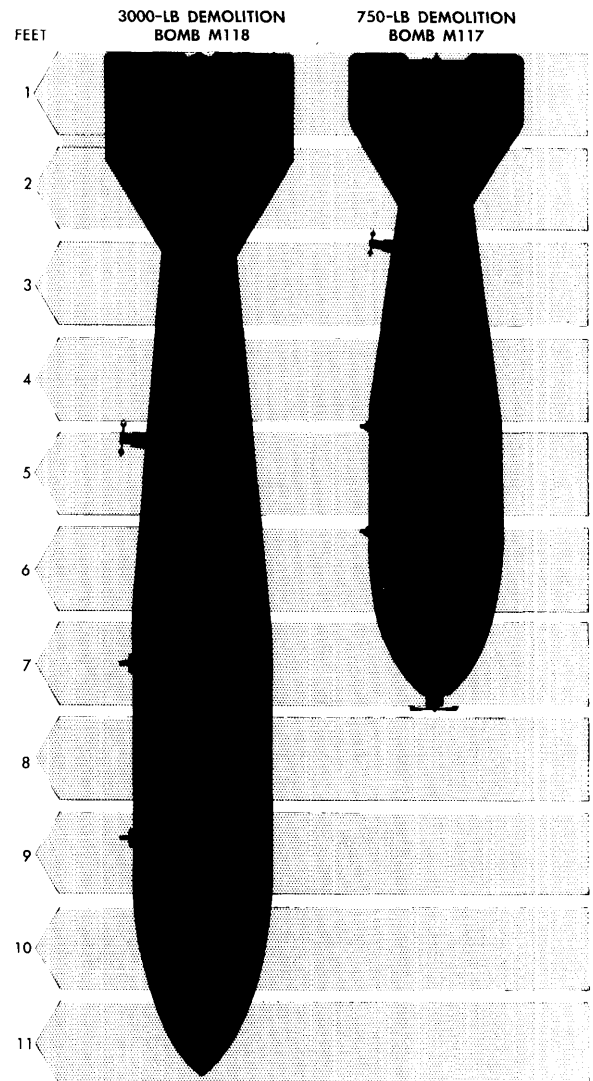

Figure 8.1—Demolition Bombs, Comparative Size.

Demolition Bombs

750-lb Demolition Bomb M117
3000-lb Demolition Bomb M118

Fuzes Compatible with Demolition Bombs

Demolition bombs use mechanical nose and tail fuzes or electric fuzes. The following fuzes are used with demolition bombs:

Nose fuzes:

AN-M103A1
VT Fuze T750
VT Fuze AN-M166
M990 (T905) (electric)

Tail fuzes:

M190 (T759)
M990 (T905) (electric)

Markings

Demolition bombs are identified by standard nomenclature stenciled in black on the bomb body and its components. Nomenclature also is stamped into the bomb body for permanent identification. The bomb body and its components are painted olive-drab.

Suspension

Two suspension lugs of the screw-in type are spaced 14 inches apart on the 750-lb Demolition Bomb M117. The 3000-lb Demolition Bomb M118 has lugs spaced 30 inches apart. The lugs are secured to the bomb body with cap screws.

Safety Precautions

Demolition bombs and their components are shipped separately and are assembled in the field to form a complete round. Thus, handling becomes less hazardous and the probability

of damage to the bomb or its components is reduced. Preparing demolition bombs for flight requires extreme care because a mis-step may prove fatal. Check and double-check, and be absolutely sure of the assembly procedure.

Safety Precautions To Be Observed

1. Fuzes and bombs shall not be unpacked in advance of requirements. If unpacked and not used, return them to their original packings.
2. Any accidentally armed fuze, even if only partially armed, must be handled only by authorized personnel.
3. Fuzes shall not be assembled to bombs in anticipation of future needs.
4. Guard fuzes against dropping or bumping at all times, to prevent premature detonation.
5. Never allow primer detonators to drop or strike an object; detonators are extremely sensitive and rough handling will explode them.
6. Screw fuze into bomb, handtight. Never use a tool for this operation, unless specifically authorized.
7. Handle and install arming vanes with care to prevent the distortion of blades, and possible malfunction of both fuze and bomb.
8. Do not remove warning tags when fuze is installed in a bomb.
9. Never remove safety cotter pins or car seals from fuzes prematurely.
10. Be careful when unpacking and installing long-stem tail fuzes; do not lose parts.
11. Replace all safety cotter pins when defuzing a bomb.
12. Do not use a fin assembly if it is damaged and cannot be secured to the bomb properly.
13. Inspect arming wires for kinks, twists, and burrs. Defective arming wires may cause a bomb to malfunction.

Section 8.2—750-lb Demolition Bomb M117

Description

The 750-lb Demolition Bomb M117 has a short ogival nose, a cylindrical body, and a tapered aft end. A conical-type fin assembly is bolted to the rear of the bomb to improve its aerodynamic performance and accuracy in flight.

Bomb M117 is designed primarily for electric fuzing. Two conduits for the electric fuze cable harness connect the nose and tail fuze cavities with a charging receptacle located between the suspension lugs on the surface of the bomb case. When electric fuzes are not used, a plug is threaded into the charging receptacle cavity. The steel nose fuze-hole plug and base fuze-hole plug are replaced in their respective cavities after electric fuzes have been installed.

Pending the availability of electric fuzes, mechanical fuzes are used in the nose cavity, tail cavity, or both. Adapter-boosters are installed in the fuze cavities when the bomb is fuzed mechanically.

The bomb uses a mechanical tail fuze which projects into the airstream on the side of the bomb fin cone, rather than straight out the aft end, figure 8.2. To accomplish this, the fuze has a flexible arming stem. To install the fuze, an access cover is removed from the side of the fin cone and the fuze body is inserted through the opening and threaded into the fuze cavity. The arming head is secured to the side of the fin cone and the arming stem then is joined to the fuze body.

Two suspension lugs, spaced 14 inches apart, are threaded into lug inserts on the bomb case. All seams and crevices are sealed with an inert sealing compound to prevent leakage. Approximately 50 percent of the total bomb weight is explosive charge.

Identifying nomenclature is stenciled in black on an olive-drab painted bomb body assembly. For permanent identification, nomenclature is stamped into the bomb body.

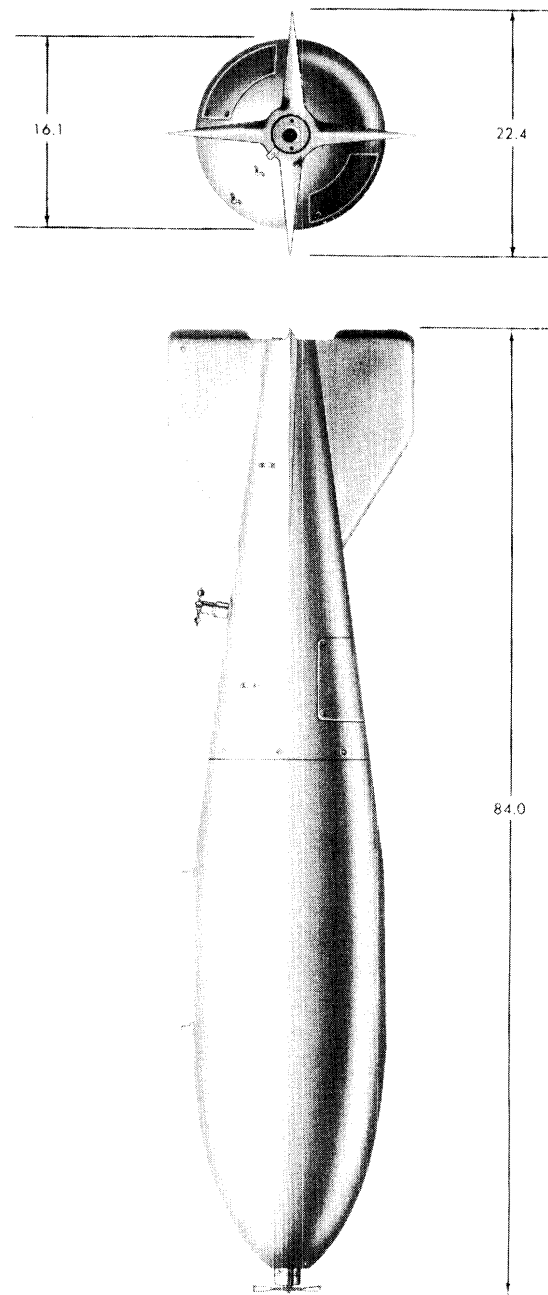

*Figure 8.2—750-lb Demolition Bomb M117
(Mechanically Fuzed).*

Physical Characteristics (Figures 8.3 and 8.4)

- Weight of assembled fuzed bomb:
 - Loaded with Tritonal... 799 lbs
- Weight of explosives:
 - Tritonal..... 386 lbs
- Weight of fin:
 - Fin Assembly M131... 44 lbs
- Dimensions:
 - Length or height of 84.00 inches complete bomb
 - Length of bomb body... 46.00 inches
 - Diameter..... 16.1 inches
 - Fin span..... 22.4 inches
 - Fin length..... 38.44 inches
- Suspension:
 - Two suspension lugs... 14 inches c to c

Components of a Complete Round

- Bomb body assembly (including):
 - Bomb body
 - Closing plugs
 - Suspension lugs
- Conical Fin Assembly M131
- Nose fuzes (one of):
 - AN-M103A1
 - VT Fuze T750
 - VT Fuze AN-M166
 - M990 (T905) (electric)

- Tail fuze (one of):
 - M190 (T759)
 - M990 (T905) (electric)
- Adapter-boosters (for mechanical fuzing):
 - T45E1 (nose)
 - T46E4 (tail)
- Fahnestock clips (for mechanical fuzing)
- Arming wire assembly

Assembly

CAUTION: Fuzes and bombs shall not be unpacked in advance of requirements. If unpacked and not used, return them to their original packings.

Mechanical Fuzing of Bomb M117

1. Remove bomb body and components from their packing cases. Remove shipping ring from rear of bomb body by unscrewing studs.

CAUTION: Inspect for damage (cracks, broken weldments, etc.) which might cause leaks in the bomb body or weaken lugs or their attachment to the bomb body.

2. Place conical fin assembly over end of the bomb with one fin in line with suspension lugs. If suspended in external racks, turn fin and locate to clear aircraft structure and ground,

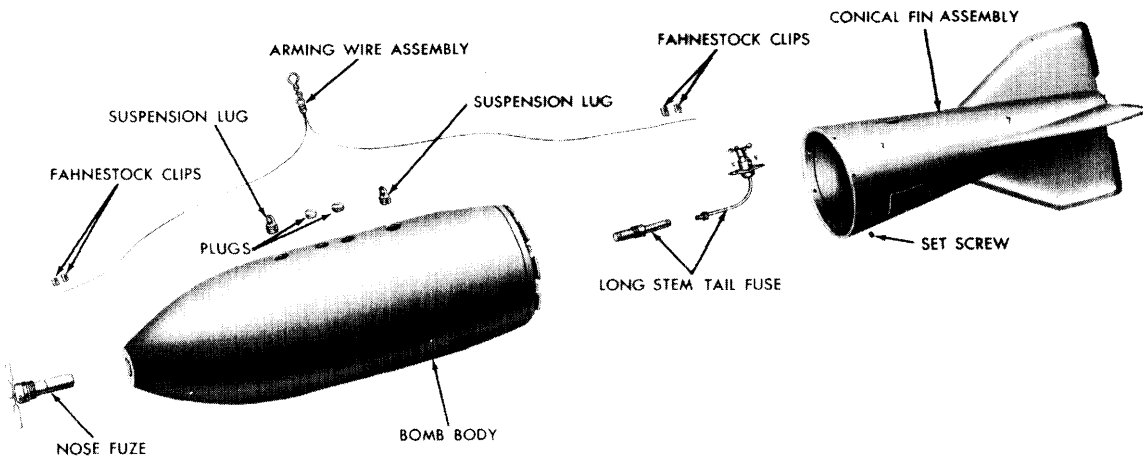

Figure 8.3—750-lb Demolition Bomb M117 (Mechanically Fuzed), Exploded View.

when installed. Secure fin to aft end of bomb with setscrews located on the edge of the cone. Assemble the two suspension lugs in their respective threaded holes.

3. Remove hand-hole cover on fin cone by taking out securing screws.

4. Remove base fuze-hole plug threaded into rear fuze cavity.

5. If nose fuze is required, remove nose fuze-hole plug.

6. Install adapter-boosters in nose and tail fuze cavities as required for mechanical fuzing.

7. Install bomb on aircraft and securely lock in place. If bomb bay does not provide enough space for fuzing, fuzing shall be done prior to hoisting bomb into place on the rack.

8. Remove required number of fuzes and arming wire assemblies from their containers.

CAUTION: If containers are punctured, split, or if the seal is broken in any way, the fuzes contained therein shall be considered unserviceable. This does not apply to fuzes repacked in the field and resealed with adhesive tape for temporary protection. These fuzes should be examined carefully for serviceability.

9. For detailed information on fuzing and defuzing, refer to OP 988 (First Revision).

10. Thread tail fuze body into tail fuze cavity, handtight.

11. Insert flexible arming stem with fuze head through fuze opening in fin cone skin. Thread retaining collar on flexible arming stem over fuze neck of fuze body and tighten by hand. Secure fuze head to fin cone skin with studs supplied with fuze.

12. Install nose fuze into nose fuze cavity, handtight.

13. Insert arming wires through suspension lugs to each fuze. Arming wire should protrude two inches beyond fuze vanes. Cut off excess wire. If tail-fuzed only, cut off one branch of the arming wire assembly. Arming wire should be free from kinks, twists, and burrs.

Electric Fuzing of Bomb M117

1. Perform the preceding steps 1 through 5 under Mechanical Fuzing.

2. Install electric fuzes in nose and tail fuze cavities.

3. Replace nose fuze-hole plug, base fuze-hole plug, and fin access hand-hole cover.

4. Remove charging receptacle plug from bomb body.

5. Install bomb on aircraft and lock securely in place. If bomb bay does not provide enough space for fuzing, fuzing shall be done prior to hoisting bomb into place on the rack.

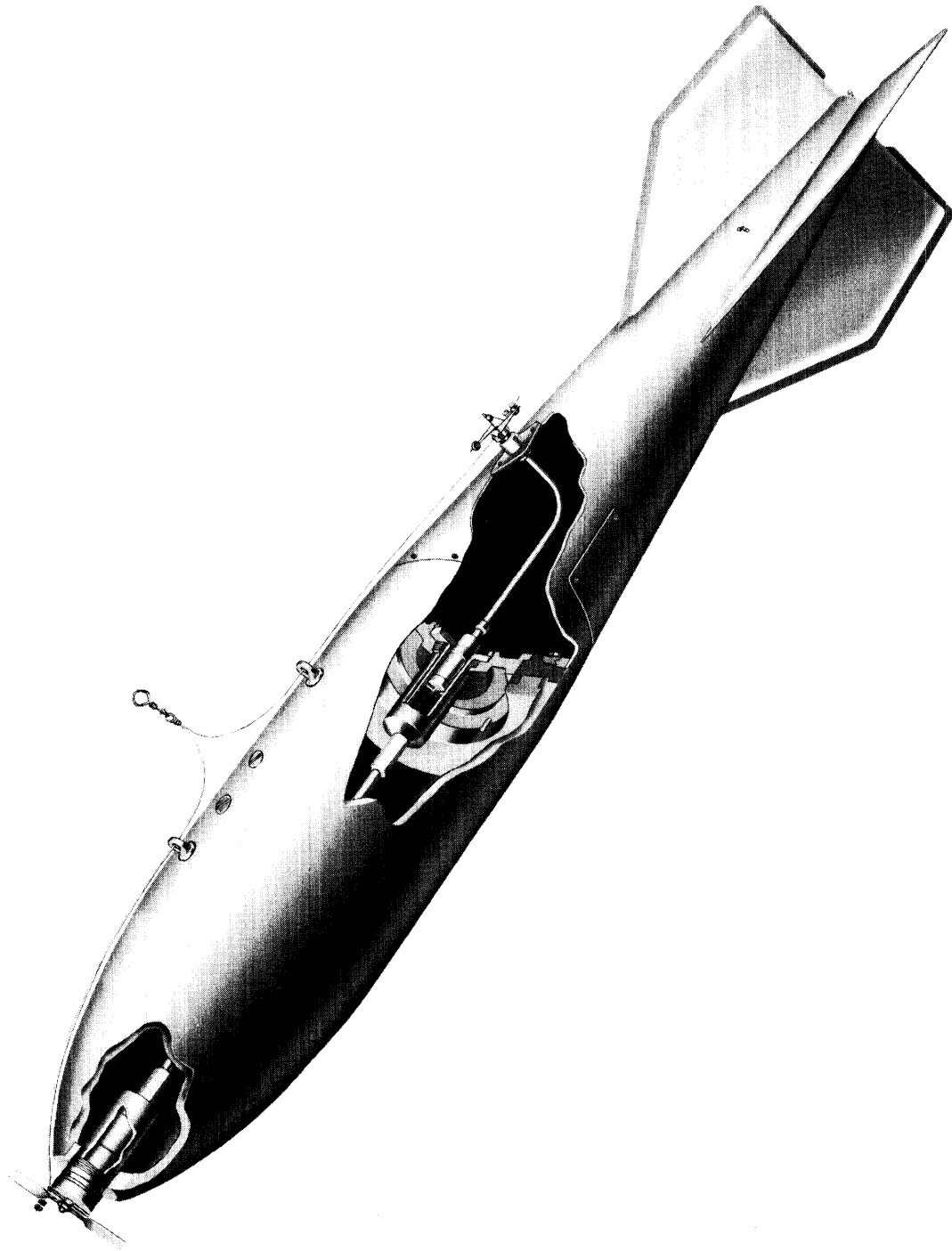

Figure 8.4—750-lb Demolition Bomb M117 (Mechanically Fuzed), Cutaway View.

Section 8.3—3000-lb Demolition Bomb M118

Description

The 3000-lb Demolition Bomb M118 has a short ogival nose, a cylindrical body, and a tapered aft end. A conical-type fin assembly is bolted to the rear of the bomb to improve its aerodynamic performance and accuracy in flight.

Bomb M118 is designed primarily for electric fuzing. Two conduits for the electric fuze cable harness connect the nose and tail fuze cavities with a charging receptacle located between the suspension lugs on the surface of the bomb case. When electric fuzes are not used, a plug is threaded into the charging receptacle cavity. The steel fuze-hole nose plug and base fuze-hole plug are replaced in their respective cavities after electric fuzes have been installed.

Pending the availability of electric fuzes, mechanical fuzes are used in the nose cavity, tail cavity, or both. Adapter-boosters are installed in the fuze cavities when the bomb is fuzed mechanically.

The bomb uses a mechanical tail fuze which projects into the airstream on the side of the bomb fin cone, rather than straight out the aft end, figure 8.5. To accomplish this, the fuze has a flexible arming stem. To install the fuze, an access cover is removed from the side of the fin cone and the fuze body is inserted through the opening and threaded into the fuze cavity. The arming head is secured to the side of the fin cone and then, the arming stem is joined to the fuze body.

Two suspension lugs, spaced 30 inches apart, are bolted to the bomb body. A single hoisting lug may be attached to the bomb at the center of gravity and may be used for an alternate 14-inch suspension mount. All seams and crevices are sealed with an inert sealing compound to prevent leakage. Approximately 65 percent of the total weight of Bomb M118 is explosive charge.

Physical Characteristics

Weight of assembled fuzed bomb:
Loaded with Tritonal 3020 lbs

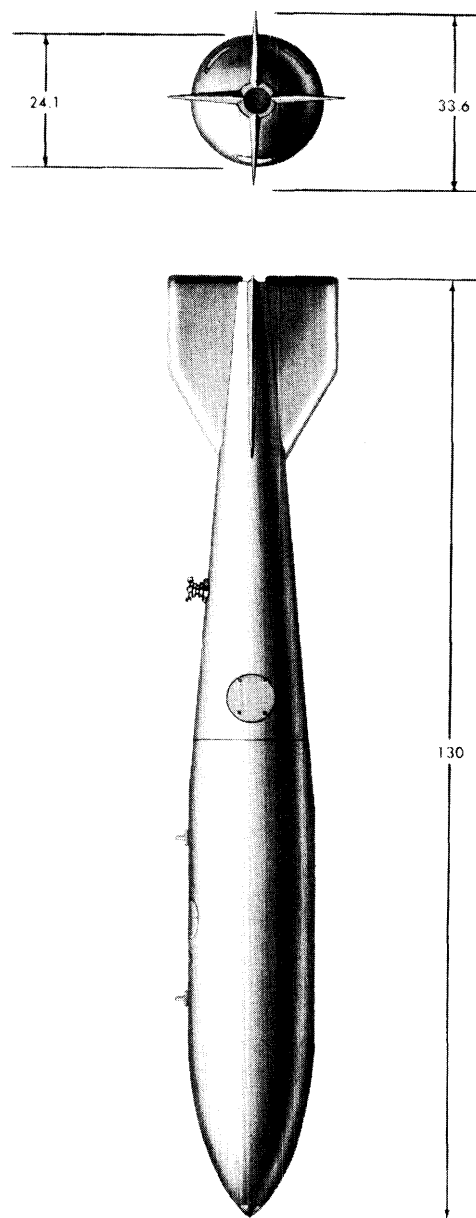

Figure 8.5—3000-lb Demolition Bomb M118
(Mechanically Fuzed).

Weight of explosive:
 Tritonal 1888 lbs
 Weight of fin:
 Fin Assembly M132... 162 lbs
 Dimensions:
 Length or height of 130 inches
 complete bomb
 Length of bomb body_ 90.13 inches
 Diameter 24.13 inches
 Fin span 14.1 inches
 Fin length 40.4 inches
 Suspension:
 Two suspension lugs... 30 inches c to c

Tail fuze (one of):
 M192 (T761)
 M990 (T905) (electric)
 Adapter-boosters (for mechanical fuzing):
 T45E1 (nose)
 T46E4 (tail)
 Fahnestock clips (for mechanical fuzing)
 Arming wire assembly

Components of a Complete Round (Figures 8.6 and 8.7)

- Bomb body assembly (including):
 - Bomb body
 - Closing plugs
 - Suspension lugs and cap screws
- Conical Fin Assembly M132
- Nose fuze (one of):
 - AN-M103A1
 - VT Fuze T750
 - VT Fuze AN-M166
 - M990 (T905) (electric)

Assembly

CAUTION: Fuzes and bombs shall not be unpacked in advance of requirements. If unpacked and not used, return them to their original packings.

Mechanical Fuzing of Bomb M118

1. Remove bomb body and components from their packing cases. Remove shipping ring from rear of bomb body by unscrewing studs.

CAUTION: Inspect for damage (cracks, broken weldments, etc.) that might cause leaks in the bomb body or weaken lugs or their attachment to the bomb body.

2. Remove hand-hole covers on fin cone by unthreading fasteners.

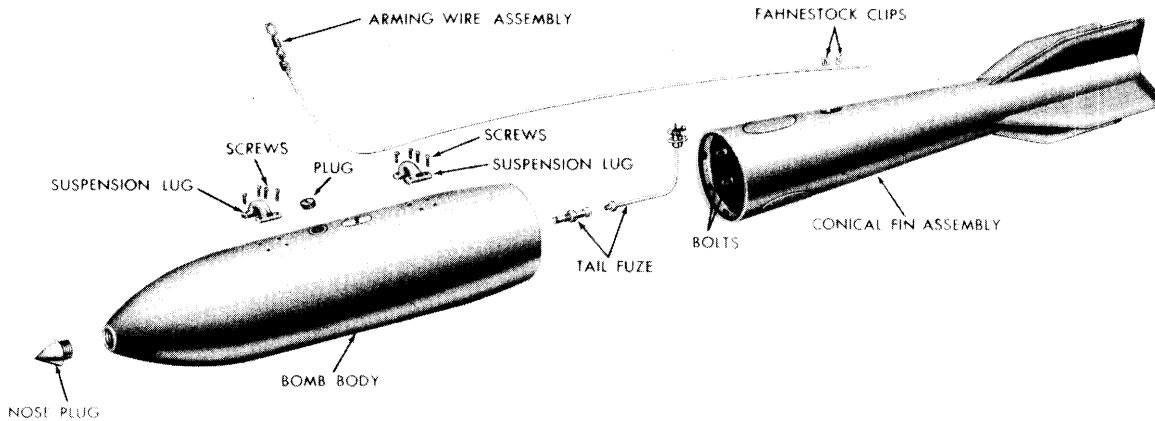

Figure 8.6—3000-lb Demolition Bomb M118 (Mechanically Fuzed), Exploded View.

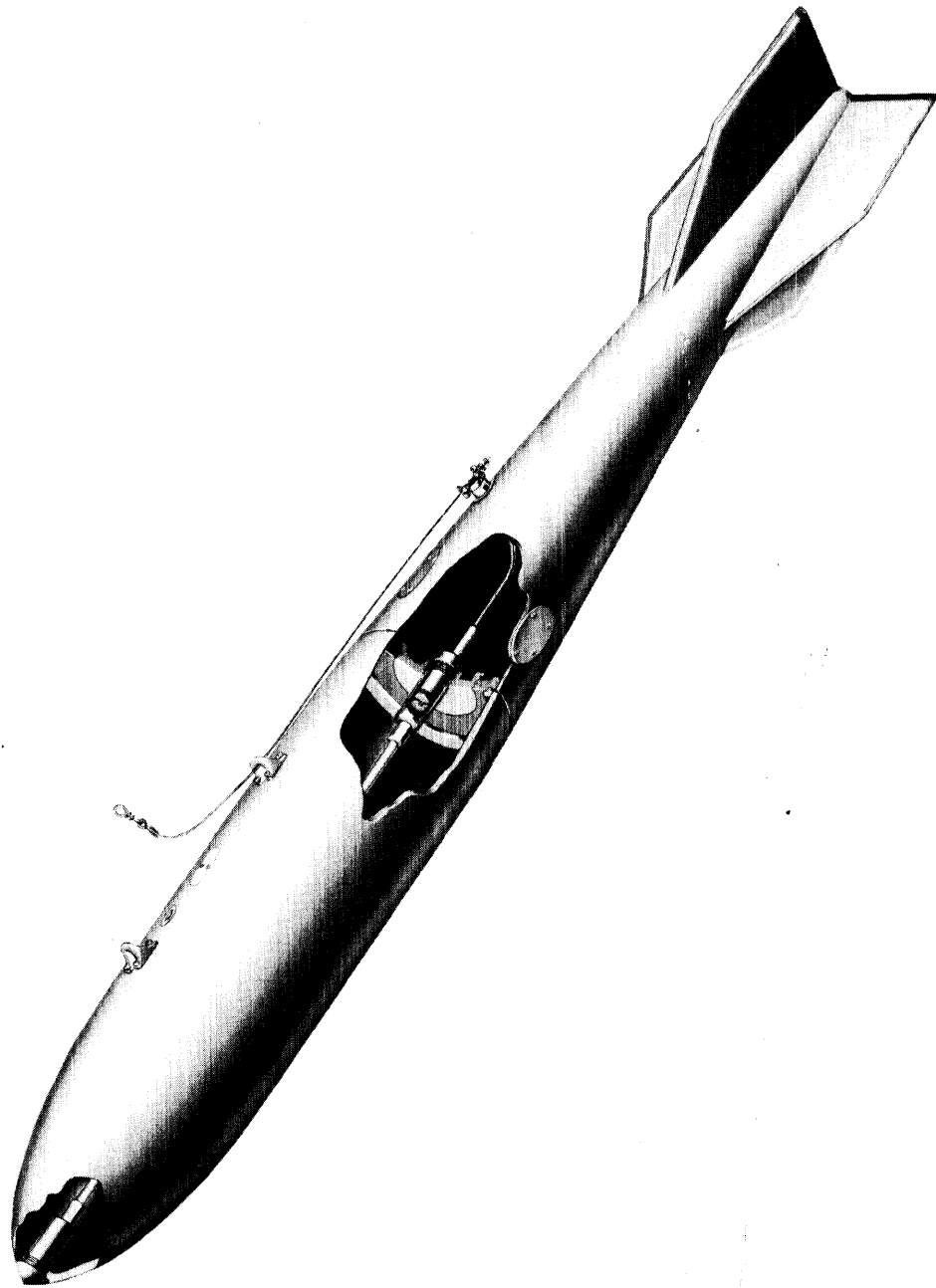

Figure 8.7—3000-lb Demolition Bomb M118 (Mechanically Fixed), Cutaway View.

3. Place conical fin assembly over end of the bomb with one fin in line with suspension lugs. If suspended in external racks, turn fin and locate to clear aircraft structure and ground, when installed. Align holes on facing plate of fin assembly with bolt holes on base plate of bomb. Place lockwashers on bolts and screw bolts into bomb body from inside the fin cone. Tighten bolts securely. Assemble the two suspension lugs to the bomb body by assembling with four cap screws.

4. Remove base fuze-hole plug threaded into rear fuze cavity.

5. If nose fuze is required, remove nose fuze-hole plug.

6. Install adapter-booster in nose and tail fuze cavities as required for mechanical fuzing.

7. Install bomb on aircraft and securely lock in place. If bomb bay does not provide enough space for fuzing, fuzing shall be done prior to hoisting bomb into place on the rack.

8. Remove required number of fuzes and arming wire assemblies from their containers.

CAUTION: If containers are punctured, split, or if the seal is broken in any way, the fuzes contained therein shall be considered unserviceable. This does not apply to fuzes repacked in the field and resealed with adhesive tape for temporary protection. These fuzes should be examined carefully for serviceability.

9. For detailed information on fuzing and defuzing, refer to OP 988 (First Revision).

10. Thread tail fuze body into tail fuze cavity, handtight.

11. Insert flexible arming stem with fuze head through fuze opening in fin cone skin. Thread retaining collar on flexible arming stem over fuze neck of fuze body and tighten by hand. Secure fuze head to fin cone skin with studs supplied with fuze.

12. Install nose fuze into nose fuze cavity, handtight.

13. Insert arming wires through suspension lugs to each fuze. Arming wire should protrude two inches beyond fuze vanes. Cut off excess wire. If tail-fuzed only, cut off one branch of the arming wire assembly. Arming wire should be free from kinks, twists, and burrs.

Electric Fuzing of Bomb M118

1. Perform the preceding steps 1 through 5 under Mechanical Fuzing.

2. Install electric fuzes in nose and tail fuze cavities.

3. Replace nose fuze-hole plug, base fuze-hole plug, and fin access hand-hole cover.

4. Remove charging receptacle plug from bomb body.

5. Install bomb in aircraft and lock securely in place. If bomb bay does not provide enough space for fuzing, fuzing shall be done prior to hoisting bomb into place on the rack.

CONFIDENTIAL

Chapter 9

AIRCRAFT DEPTH BOMBS

Section 9.1—General

Section 9.2—350-lb Aircraft Depth Bomb AN-Mk 54 Mods 0 and 1

CONFIDENTIAL

358615 O—55—12

169-170

Chapter 9

AIRCRAFT DEPTH BOMBS

Section 9.1—General

Description

Aircraft depth bombs (AD) generally are cylindrical in shape with flat noses and thin walls. The flat nose is used to reduce ricochet upon water impact, and the thin walls enable the body to contain more explosive.

Detonation of such bombs usually is effected below the surface of the water through the use of a hydrostatic fuze. At present, the hydrostatic fuzes which are in service are all for tail installation. The pre-setting of the hydrostatic tail fuze determines the depth at which the bomb will detonate.

Provisions also are made for the installation of a nose fuze; in many cases, aircraft depth bombs are dual-fuzed, using an impact nose fuze in conjunction with the hydrostatic tail fuze. Through selective arming, either fuze, or both, may be freed to arm when the bomb is released. The tactical situation will dictate the manner in which the bomb will be armed and detonated.

Approximately 70 percent of the total weight of an AD Bomb is its high-explosive filler. This filler may be either TNT or HBX.

Usage

Aircraft depth bombs primarily are intended for use against underwater targets, such as submarines. The lethal radius of underwater effectiveness of a 350-lb bomb is approximately 17 feet. Damage from underwater explosion of this bomb may be expected to a distance of 45 feet.

The use of aircraft depth bombs is restricted as follows:

1. Aircraft depth bombs will not penetrate solid materials; instead, they will break up on such contact and detonation probably will result.
2. Aircraft depth bombs should not be

released at high altitudes. If released from such heights, either the bomb will detonate at depths greater than the setting made on the hydrostatic fuze or the bomb body and fuze cavity will be distorted by the impact, causing malfunction of the fuze.

Aircraft Depth Bombs

At present, the 350-lb Bombs AN-Mk 54 Mod 1 and Mod 0 are the only aircraft depth bombs used by the Navy.

Fuzes Compatible with Aircraft Depth Bombs

Aircraft depth bombs often use the combination of a hydrostatic tail fuze and an impact nose fuze. Fuzes used with AD bombs are:

Nose fuze:

AN-M103A1 (Use flat vane—30° pitch)

Tail fuze:

AN-Mk 230 and Mods 4, 5, and 6 (Use Arming Bracket Mk 1—Dwg 300207.)

Markings

Yellow bands painted on the nose and tail end of an aircraft depth bomb identify its high-explosive content. Identifying nomenclature is stenciled in black on the olive-drab case.

Suspension

Aircraft depth bombs generally are designed for standard 14-inch suspension. Diametrically opposite the standard suspension lugs, a single suspension lug is located at the bomb's center of gravity. Tapped holes are provided for attaching the hoisting lugs which may be needed for installing the bomb in the aircraft. When not in use, these holes are plugged with special protective plugs.

Safety Precautions

Components of an aircraft depth bomb are shipped separately and are assembled in the field to form the complete round. Because of their light construction, aircraft depth bomb bodies and fin assemblies are shipped in metal packing crates. Assembly of the complete round and the depth fuze setting is accomplished prior to flight. The assembly and installation of a bomb requires extreme care because a mis-step may prove fatal. Be sure of the procedure, and follow assembly instructions carefully.

Safety Precautions To Be Observed

1. Fuzes and bombs shall not be unpacked in advance of requirements; if unpacked and not used, return them to their original packings.
2. Armed fuzes shall be removed and destroyed by authorized personnel only.
3. Fuzes shall not be installed in the bomb in anticipation of future needs.
4. Guard fuzes against dropping and bumping.
5. Screw hydrostatic tail fuze into bomb, by hand. Be sure that fuze gasket is in place. Tighten fuze securely with a spanner wrench.
6. Handle and install arming vanes with care to prevent distortion of blades. Install arming wire bracket on tail fuze.
7. Do not remove safety cotter pins or car seals from fuzes prematurely.
8. Replace all safety pins when defuzing a bomb.
9. Depth bomb bodies have light cases, and therefore dent easily. Be careful when handling bomb bodies to prevent bumping or dropping them.
10. Do not use a fin assembly if it cannot be secured to the bomb properly.
11. Inspect arming wire for kinks, twists, and burrs. Such defects may cause a bomb to malfunction.

Section 9.2—350-lb Aircraft Depth Bomb AN-Mk 54 Mods 0 and 1

Description

The 350-lb AD Bomb AN-Mk 54 Mod 1, figure 9.1, is a flat-nosed, thin wall bomb. The fin assembly consists of a fin cone and four fins, circumscribed with a shroud, and is attached to the aft end of the bomb body by cap screws. This bomb is intended for use against underwater targets. The flat nose prevents ricochet upon water impact. The depth of detonation is determined by the setting of the hydrostatic tail fuze. Generally, depth bombs are only tail-fuzed. Provision also is made for nose fuzing in the event a blast effect is desired. With both fuzes installed, the aircraft depth bomb may be armed selectively by releasing one of the arming wires with the bomb. Depth setting is made prior to flight.

The lethal radius of underwater effectiveness of AD Bomb AN-Mk 54 is approximately 17 feet; however, damage may be expected up to 45 feet from the center of the blast.

Yellow bands painted on the nose and aft end of the bomb body identify the high-explosive filler of TNT or HBX. Identifying nomenclature is stenciled in black on the olive-drab bomb body.

Two suspension lugs are welded to the body 14 inches apart, and a single suspension lug is located diametrically opposite. Tapped holes are provided for attaching hoisting lugs which may be needed for the handling of the bomb. These holes are plugged with special protective plugs when not in use. Approximately 70 percent of the 350-lb AD bomb AN-Mk 54 is high-explosive filler.

Differences Between Bombs AN-Mk 54 Mod 0 and AN-Mk 54 Mod 1

On the earlier modification of AN-Mk 54, the Mod 0, the bomb body is provided without suspension lugs attached. The suspension lugs are attached in the field with cap screws; all of the fitting holes are plugged.

The Mod 0 and Mod 1 bomb bodies are shipped as a complete unit, packed in a metal crate.

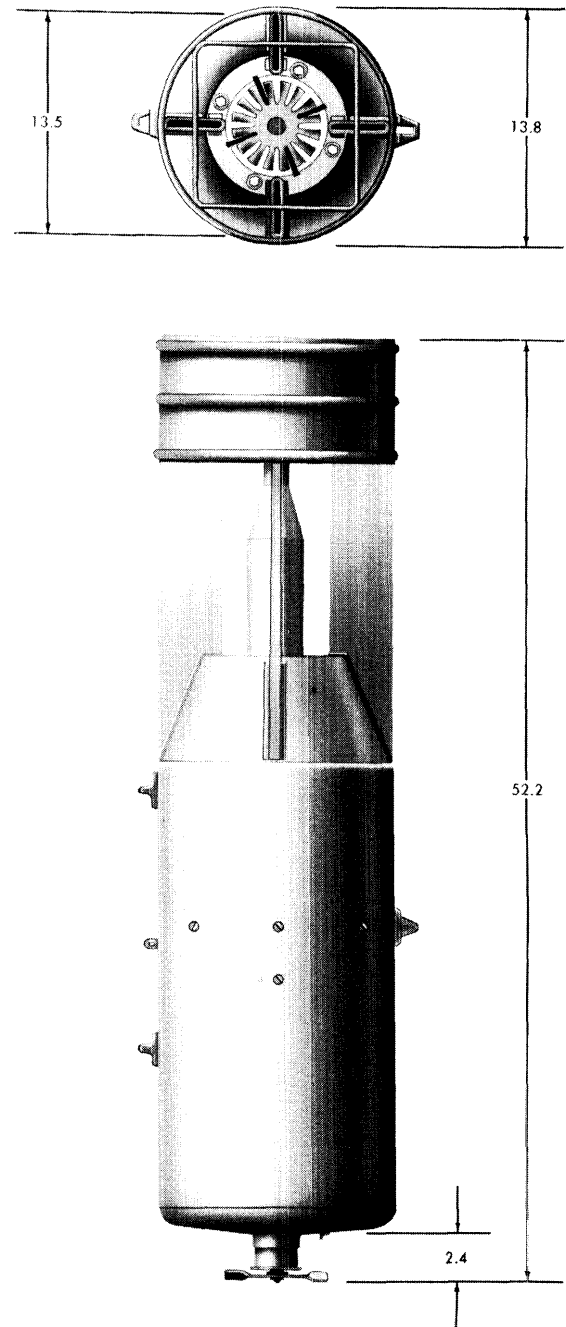

Figure 9.1—350-lb Aircraft Depth Bomb AN-Mk 54 Mod 1.

Physical Characteristics

Weight of assembled fuze**d** bomb:
 Loaded with HBX..... 346.3 lbs
 Loaded with TNT..... 323.8 lbs

Weight of explosive:
 HBX..... 248.0 lbs
 TNT..... 225.5 lbs

Weight of fin..... 19.5 lbs

Dimensions:
 Length of complete bomb 52.2 inches
 Length of bomb body.. 34.2 inches
 Diameter..... 13.5 inches
 Fin diameter..... 13.8 inches
 Fin length..... 24.5 inches

Suspension:
 Two suspension lugs... 14 inches c to c
 Single suspension lug.. Center of gravity

Components of a Complete Round (Figures 9.2 and 9.3)

Bomb body assembly (including):

- Bomb body
- Cap screws
- Closing plugs

Fin assembly

Nose fuze:

AN-M103A1 (Use flat vane with 30° pitch)

Tail fuze:

AN-Mk 230 and Mods 4, 5, and 6 (Use Arming Bracket Mk 1—Dwg 300207)
 Arming Wire Assembly Mk 1 (2)
 Fahnestock clips

Assembly

CAUTION: Fuzes and bombs shall not be unpacked in advance of requirements. Fuzes and bombs which are unpacked and not used must be returned to their original packings.

1. Open shipping crate by removing cotter pins from three lid latches. Unthread hex-head screws from bands which secure the bomb in the case. Lift bomb body out of case.

CAUTION: Bomb body is easily damaged because of its light construction. Inspect for damage.

2. Remove closing plugs which seal fuze cavities.

3. Attach suspension lugs if required.

4. Remove fin assembly and attachments from shipping crate. Place fin assembly over conical end of bomb so that one fin is in line with the suspension lugs. Secure with hex-head cap screws.

CAUTION: Do not use fin assembly if it cannot be secured to the bomb properly.

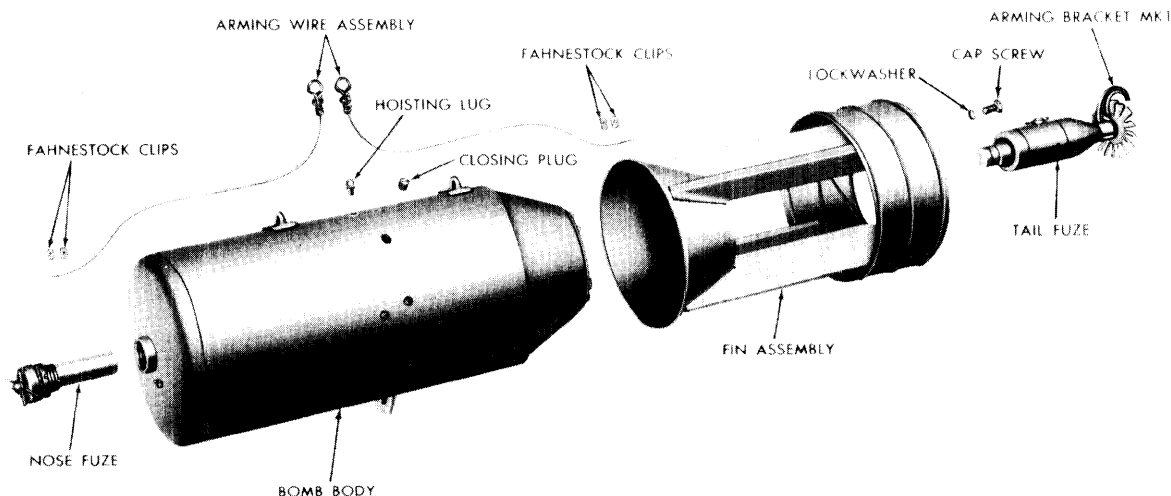

Figure 9.2—350-lb Aircraft Depth Bomb AN-Mk 54 Mod 1, Exploded View.

5. Hoist and secure bomb to aircraft. If bomb bay does not provide sufficient room for the fuzing operation, it shall be done prior to hoisting bomb into place.

6. Remove required number of fuzes and arming wire assemblies from their containers.

CAUTION: If containers are punctured, split, or if the seals have been broken, the fuzes contained

therein shall be considered unserviceable. This does not apply to fuzes which have been repacked in the field and resealed with adhesive tape for temporary protection. These fuzes should be examined carefully for serviceability.

7. For detailed information on fuzing and defuzing, refer to OP 988 (First Revision).

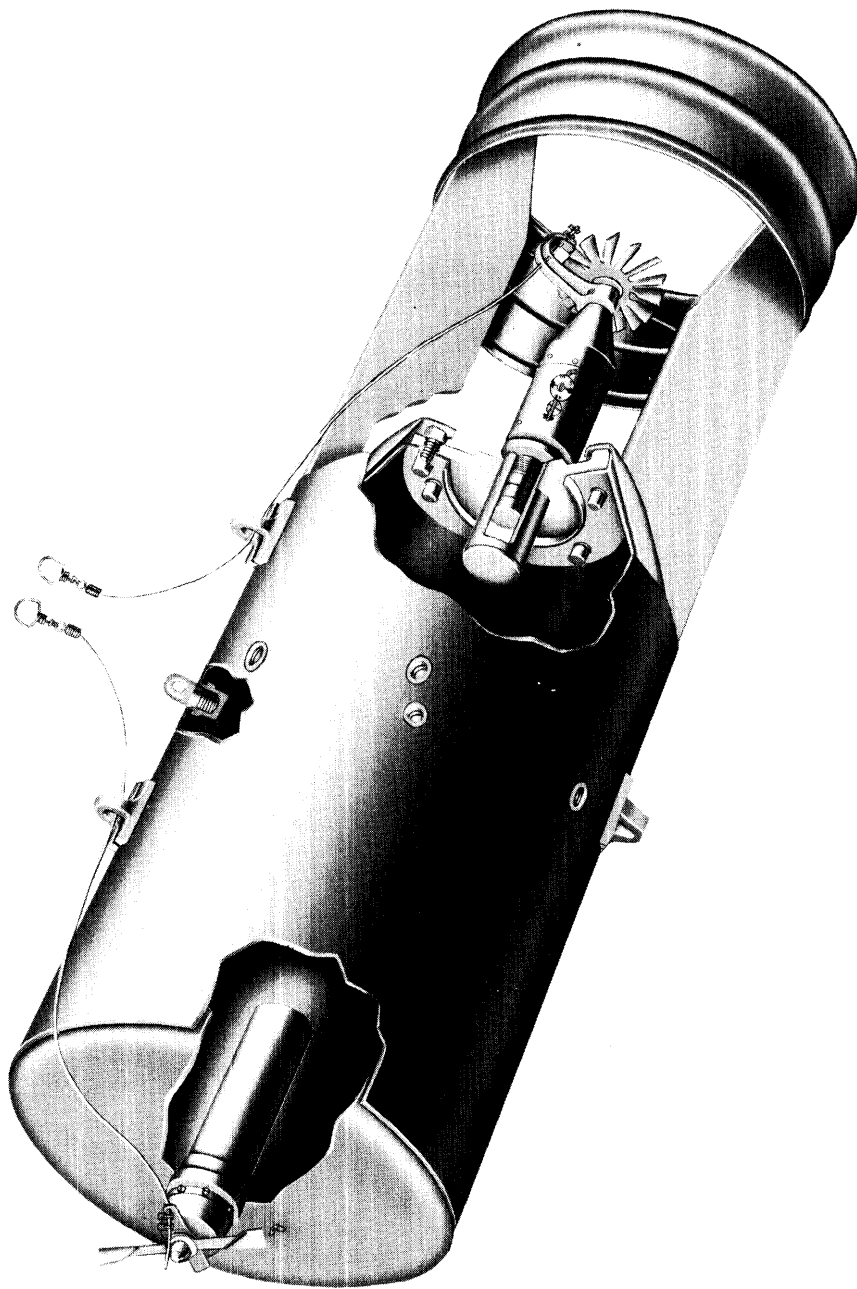

Figure 9.3—350-lb Aircraft Depth Bomb AN-Mk 54 Mod 1, Cutaway View.

Chapter 10

MINIATURE PRACTICE BOMBS

Section 10.1—General

**Section 10.2—3-lb Miniature Practice Bomb Mk 5 Mods 0, 1, 2, and 3
3-lb Miniature Practice Bomb AN-Mk 23 Mods 0 and 1
4.5-lb Miniature Practice Bomb Mk 43 Mods 0 and 1**

Section 10.3—13-lb Miniature Practice Bomb Mk 19 Mods 0 and 1

Chapter 10 MINIATURE PRACTICE BOMBS

Section 10.1—General

Description

Miniature practice bombs (MP) figure 10.1, have bodies cast from lead, iron, steel, or lead antimony. Weights of miniature practice bombs range from 3 pounds to 13 pounds depending upon the density of the material and the size of the body. In the 13-lb MP Bomb Mk 19 Mod 1, steel fin blades are inserted into the mold prior to casting the bomb body. Fin blades are cast integrally for the 3- and 4.5-lb MP bombs.

A hole in the nose of each bomb body houses either Signal AN-Mk 4 or Mk 5. AN-Mk 4 is a smoke signal while the Mk 5 contains a fluorescein dye. Signal AN-Mk 4 is used for both land and water drops. Signal Mk 5 is used for water drops. These signals may be fired upon impact with either a solid object or water. A cotter or straight pin locks the signal and firing pin assembly in the nose of the bomb. The firing pin assembly is not used when Signal Mk 5 is installed. A metal shroud is used to help stabilize the flight of most miniature practice bombs.

Usage

Miniature practice bombs are used to train both Navy and Air Force personnel for either horizontal, glide, or dive bombing. MP Bomb Mk 23 should not be used against armored-deck target boats.

Miniature Practice Bombs

3-lb Miniature Practice Bomb Mk 5 and Mods

3-lb Miniature Practice Bomb AN-Mk 23 Mods

4.5-lb Miniature Practice Bomb Mk 43 and Mods

13-lb Miniature Practice Bomb Mk 19 Mod 0 and Mod 1

AN-Mk 23 Mod 1 is service issue. Bombs Mk 5, Mk 19, and Mk 43 contain critical material and their use is restricted.

CONFIDENTIAL

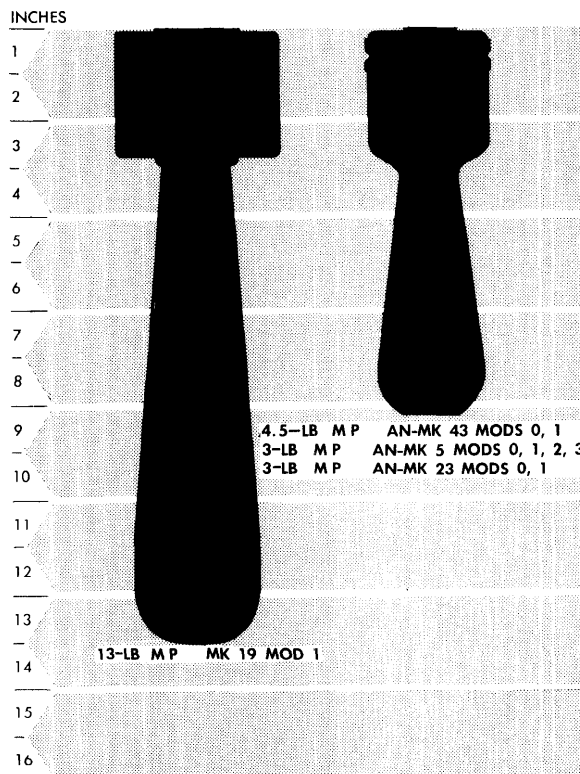

Figure 10.1—Miniature Practice Bombs, Comparative Size.

Signals Compatible with Miniature Practice Bombs

Miniature practice bombs use a spotting signal or cartridge which upon detonation produces a puff of smoke or a fluorescein-dye mark on the target. The following signals are used with MP bombs:

Signal AN-Mk 4 and Mods (smoke)

Signal Mk 5 (fluorescein dye)

Markings

There are no color markings for the 3-lb and 4.5-lb miniature practice bombs. The bomb is the color of the cast finish. Nomenclature is stamped into the bomb body for permanent identification.

The 13-lb MP Bomb Mk 19 Mod 0 and Mod 1 has approximately three inches of its tail section dipped in black lacquer or paint. Nomenclature is stenciled in black letters on the bomb body. Complete identifying nomenclature is stenciled in black letters on the packing crate.

Suspension

The 3-lb and 4.5-lb MP Bombs are suspended in special containers which hold 8 bombs. The 13-lb MP Bomb Mk 19 Mod 0 and Mod 1 are suspended individually in special racks. The bombs may be released individually, in rotation, or in a group.

Safety Precautions

Most bombs and their components are shipped separately and are assembled in the field to form a complete round. The miniature practice bombs are shipped with firing pin assemblies and retaining pins installed. Practice bomb signals are issued separately. Preparing an MP bomb for flight requires extreme care because a mis-step may prove fatal. Take nothing for granted; be absolutely sure of the assembly procedures.

Safety Precautions To Be Observed

1. Signals and bombs should not be unpacked in advance of requirements, if unpacked and not used, return them to their original packings.

2. Signals must not be swollen or deformed in any manner. The primer must be flush or

slightly below the base of the cartridge. Deformed signal cartridges shall not be used.

3. Guard signals against dropping or bumping at all times, to prevent accidental detonation.

4. Be sure the firing pin cup is not deformed and that the firing pin point is below the lip of the cup.

5. Check the bore of the bomb; the bore must be clean and smooth and not damaged in any way.

6. Do not force a signal into a bomb; it must fall gently into place under its own weight.

7. Do not apply pressure to a firing pin assembly because it might collapse and fire Signal AN-Mk 4.

8. Do not bend ends of the cotter pins at right angles, or strike the ends to bend into position.

9. When handling miniature practice bombs loaded with Signal AN-Mk 4, be extremely careful not to jar or drop the bomb. A sudden impact may set off the signal.

10. Do not point either end of the bomb toward other personnel.

11. During loading operations, loaders must not move their heads in line with the nose or rear of the bomb.

12. Do not strike bomb nose against any object to loosen the firing pin assembly or cartridge.

13. Protect Practice Bomb Signals AN-Mk 4 and Mk 5 during stowage from moisture, excessive motion, and vibration.

**Section 10.2—3-lb Miniature Practice Bomb Mk 5 Mods 0, 1, 2, and 3
3-lb Miniature Practice Bomb AN-Mk 23 Mods 0 and 1
4.5-lb Miniature Practice Bomb Mk 43 Mods 0 and 1**

Description

The 3-lb MP Bomb Mk 5, the 3-lb MP Bomb AN-Mk 23, and the 4.5-lb MP Bomb Mk 43 are similar to each other in physical appearance. A cast body houses the signal and firing pin assembly. A cotter pin locks the signal and firing pin assembly in the nose of the bomb. When Signal Mk 5 is installed, the firing pin assembly is not used. The four blades composing the fin are cast integrally with the bomb body. A metal shroud is used to help stabilize the flight of miniature practice bombs. The shroud forms a rectangular box section. Looseness of the shroud is taken up by forming the shroud metal around the edge of the fin. Two crimps, 180 degrees apart, anchor the shroud to the fin blades.

There are no color markings on these bombs; the bombs are the color of the cast metal. Identifying nomenclature is stamped into the surface of the metal body.

Miniature Practice Bombs Mk 5, AN-Mk 23, and Mk 43 are used for either horizontal, glide, or dive bombing practice. They are used with a signal that produces a puff of smoke upon detonation. The signal is initiated upon the bomb's impact with either a solid object or water. Miniature practice bombs use Signals AN-Mk 4 and Mk 5 for spotting purposes. Signal AN-Mk 4 is a smoke signal while Signal Mk 5 contains a fluorescein dye for spotting on water. Special containers are used for carrying and releasing miniature practice bombs.

Differences in Models

The basic difference between Bombs Mk 5, AN-Mk 23, and Mk 43 is the metal used to cast the bomb body.

Bomb Mk 5 is manufactured from zinc alloy and weighs the least of the three bombs. This bomb is used for bombing practice on armored-deck target boats. A sheet-metal stabilizing shroud is used on Mods 2 and 3.

Bomb AN-Mk 23 is manufactured from cast iron and weighs approximately 3.0 pounds.

The Mod 1 has a sheet-metal stabilizing shroud across its tail vanes, figure 10.2. Cast-iron miniature practice bombs are used on all practice runs other than those involving armored-deck target boats.

Bomb Mk 43 is a lead casting weighing approximately 4.5 pounds. A sheet-metal shroud is attached to the fins of the Mod 1. The Mk 43 is employed for low-altitude, horizontal or dive bombing and may be used on armored-deck target boats.

The first modification of these three bombs consisted generally of adding the sheet-steel shroud to the fin blades. Later modifications involved slight changes in manufacturing tolerances and specifications.

Physical Characteristics of MP Bomb Mk 5

Weight of assembled bomb with signal:

Loaded with Signal AN-Mk 4 2 lbs 11 oz

Loaded with Signal Mk 5 2 lbs 10 oz

Weight of signal:

Signal AN-Mk 4 2 oz

Signal Mk 5 1 oz

Dimensions:

Length or height of complete bomb 8.25 inches

Length of bomb body 8.25 inches

Diameter 2.18 inches

Fin span 2.5 inches

Fin length 3.0 inches

Suspension in containers containing 8 bombs.

Physical Characteristics of MP Bomb AN-Mk 23 (Figures 10.3 and 10.4)

Weight of assembled bomb with signal:

Loaded with Signal AN-Mk 4 3 lbs

Loaded with Signal Mk 5 2 lbs 15 oz

Weight of signal:

Signal AN-Mk 4 2 oz

Signal Mk 5 1 oz

Dimensions:

Length or height of complete bomb 8.25 inches

Dimensions--Continued

- Length of bomb body----- 8.25 inches
- Diameter----- 2.18 inches
- Fin span----- 2.5 inches
- Fin length----- 3.0 inches
- Suspension in containers containing 8 bombs.

Physical Characteristics of MP Bomb Mk 43

Weight of assembled bomb with signal:

Loaded with Signal AN- Mk 4 4 lbs 7 oz

Loaded with Signal Mk 5 4 lbs 6 oz

Weight of signal:

Signal AN-Mk 4----- 2 oz

Signal Mk 5----- 1 oz

Dimensions:

- Length or height of complete bomb----- 8.25 inches
- Length of bomb body----- 8.25 inches
- Diameter----- 2.18 inches
- Fin span----- 2.5 inches
- Fin length----- 3.0 inches
- Suspension in containers containing 8 bombs.

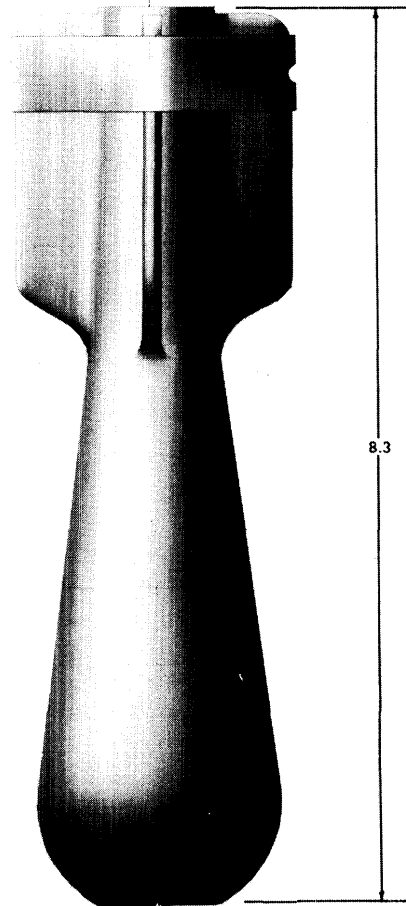
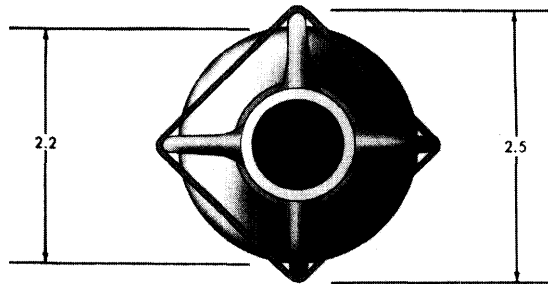

Components of a Complete Round

Bomb body assembly (including):

- Bomb body
- Cotter pin
- Firing Pin Assembly Mk 1 Mod 0

Signal (one of):

- AN-Mk 4
- Mk 5

Assembly

CAUTION: Signals and bombs shall not be unpacked in advance of requirements; if unpacked and not used, return them to their original packings. Miniature practice bombs may be salvaged and reused if the operation permits. Salvaged bombs must be free from defects, and bore must be free from damage.

Assembly Using Signal AN-Mk 4

1. Remove required number of bombs and signals from their packings. Miniature practice bombs are shipped from the manufacturer

Figure 10.2—3-lb Miniature Practice Bomb AN-Mk 23 Mod 1.

with a firing pin assembly and a retaining cotter pin installed.

2. Remove cotter pin and firing pin assembly from nose of bomb.

CAUTION: Firing pin assemblies must fit loosely and not bind when dropped into position under their own weight. Inspect firing pin assembly for damage. Be sure firing pin cup is not deformed and that the firing-pin point is below the lip of its cup. Check the bore through center of bomb; bore must be clean and smooth, and not damaged in any way.

3. With firing pin assembly removed, place bomb in a vertical position with the nose end up.

4. Insert signal into bomb, primer end up, and let it gently fall into place. Do not force into place. The base flange must rest on the bomb bore shoulder.

CAUTION: Signals must not be swollen or deformed in any manner. The primer must be flush or slightly below the base of the cartridge. Signal cartridges that are deformed in any way shall not be used.

5. Carefully insert firing pin assembly, with the firing pin end toward the signal.

CAUTION: Firing pin assembly must drop into place under its own weight. Do not apply pressure to force the firing pin assembly into the bomb because the assembly may collapse and fire the signal.

6. Rotate firing pin assembly so that the two notches in the lip line up with the two pin holes in the bomb nose. Do not exert pressure on the firing pin during this operation.

7. Insert cotter pin through the nose holes—and the recesses in the firing pin assembly.

8. Spread the ends of the cotter pin sufficiently with a screwdriver to retain it in the bomb.

CAUTION: Do not bend the ends at right angles to the axis of the cotter pin, or strike the ends to bend into position.

Assembly Using Fluorescein Signal Mk 5

1. The miniature practice bomb is prepared for use by removing the cotter pin and firing pin assembly as described in the procedure for installing Signal AN-Mk 4.

2. Insert Signal Mk 5 with the small end of the signal toward the tail of the bomb.

3. Secure signal in the bomb by replacing cotter pin.

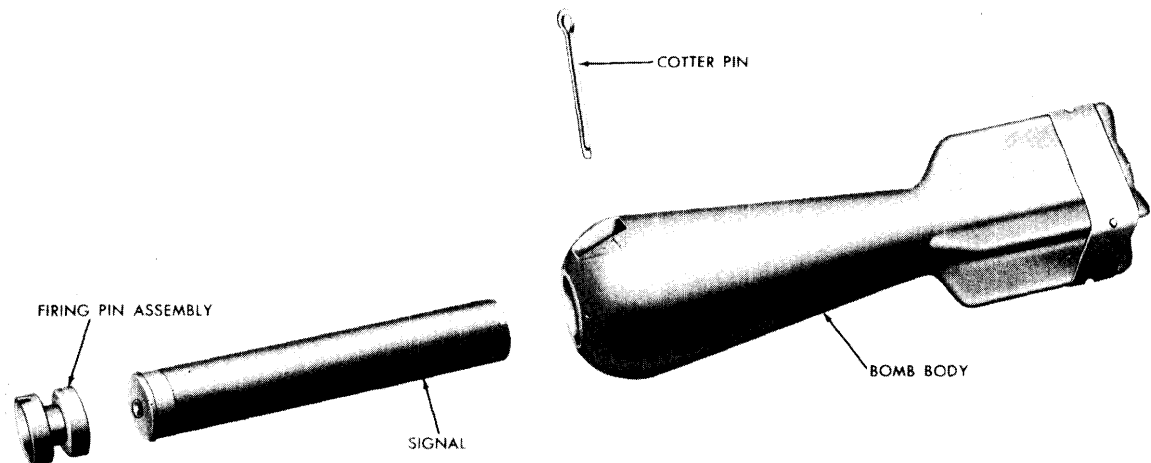

Figure 10.3—3-lb Miniature Practice Bomb AN-Mk 23 Mod 1, Exploded View.

4. Spread ends of cotter pin sufficiently to hold cotter pin in place.

5. Retain the discarded firing pin assemblies as spares, or return them to the nearest supply point.

CAUTION: When handling miniature practice bombs loaded with Signals AN-Mk 4 or Mk 5 be extremely careful not to set off the signal by jarring or dropping the bomb. Do not, under

any circumstance, point either end towards other personnel. During loading operations, loaders must not place their heads in line with the nose or tail end of the bomb. Signals AN-Mk 4 and Mk 5 must be protected from moisture, excessive motion, and vibration. In addition, Signal AN-Mk 4 must be stowed in a place protected from sunlight and excessive heat.

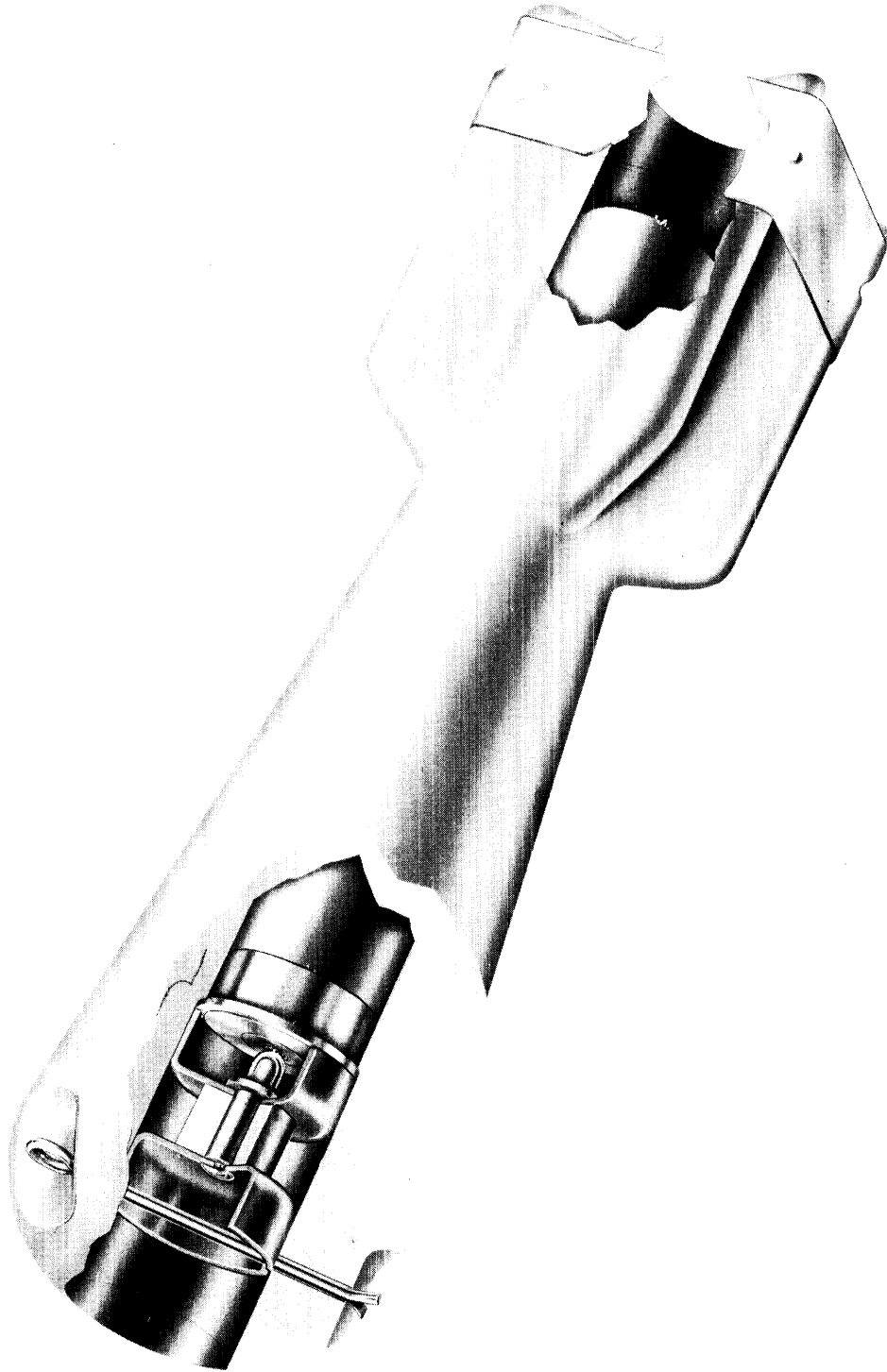

Figure 10.4—3-lb Miniature Practice Bomb AN-Mk 23 Mod 1, Cutaway View.

Section 10.3—Miniature Practice Bomb Mk 19 Mods 0 and 1

Description

The 13-lb MP Bomb Mk 19 Mod 1, figure 10.5, is an elongated, cast-metal bomb. It has a center bore running from the nose to the fin of the bomb. The body is cast lead-antimony. Four steel sheet-metal vanes are cast in place perpendicular to the axis of the bomb. A hole in the bomb nose houses the signal and firing pin assembly. A straight steel pin is inserted through the nose, retaining the firing pin assembly and signal. When Signal Mk 5 is installed, the firing pin assembly is not used. Finished body and vanes are dipped in black lacquer or paint, coating approximately three inches of the tail section. Nomenclature is stenciled in black letters on the bomb body.

This bomb is used for high-altitude horizontal bombing practice and is used against armored-deck target boats.

The retaining pin of Bomb Mk 19 Mod 1 is secured in place by fixing a patch of tape over each pin hole or by peening a small amount of lead over the ends of the pin. No other method is used to secure the pin in place.

Differences Between Bombs Mk 19 Mod 0 and Mk 19 Mod 1

The differences between Bombs Mk 19 Mod 0 and Mod 1 is in the bore construction and the method of attaching the sheet-metal fin to the body. The center bore of the Mod 0 is lined with a steel sleeve; the Mod 1 has no such lining. The lead-antimony body itself forms the lining of the Mod 1 bore. Mk 19 Mod 0 with steel sleeve must not be used on armored-deck target boats.

Physical Characteristics

Weight of assembled bomb with signal:

Loaded with Signal AN— 13.2 lbs
Mk 4

Loaded with Signal Mk 5— 13.0 lbs

Weight of signal:

Signal AN—Mk 4..... 2 oz

Signal Mk 5..... 1 oz

Dimensions:

Length or height of complete bomb 13.06 inches

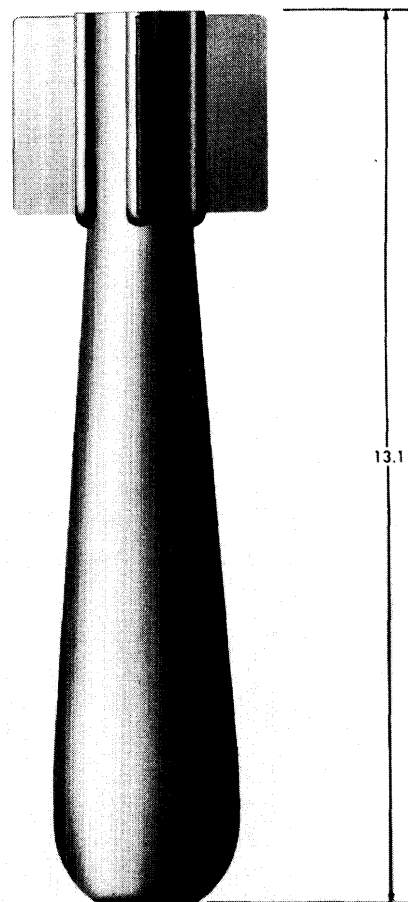
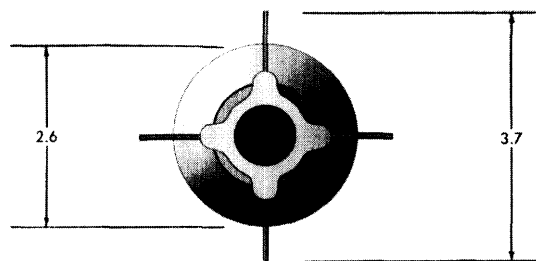

Figure 10.5—13-lb Miniature Practice Bomb Mk 19 Mod 1.

Length of bomb body	13.06 inches
Diameter	2.63 inches
Fin span	3.67 inches
Fin length	2.9 inches

Suspension:
Suspended singly in special racks.

Components of a Complete Round (Figures 10.6 and 10.7)

Bomb body assembly (including):

- Bomb body
- Retaining pin
- Firing pin assembly

Signal (one of):

- AN-Mk 4
- Mk 5

Assembly

CAUTION: Signals and bombs shall not be unpacked in advance of requirements; if unpacked and not used, return them to their original packings.

Assembly Using Signal AN-Mk 4

1. Remove required number of bombs and signals from their packings. Miniature Practice Bomb Mk 19 Mod 1 is issued with a firing pin assembly installed and a retaining pin through the nose end. Two pieces of tape ap-

plied over the pin holes prevent the pins from slipping out.

2. Remove tape from retaining pin holes. Remove retaining pin and firing pin assembly from nose end of bomb.

CAUTION: Firing pin assemblies must fit loosely and not bind when dropped into position by their own weight. Inspect firing pin assembly for damage. Be sure firing pin cup is not deformed and that the firing-pin point is below the lip of the cup. Check bore through center of the bomb, bore must be clean and smooth, and not damaged in any way.

3. With firing pin assembly removed, place bomb in a vertical position with the nose end up.

4. Insert signal in bomb, primer end up, and let it gently fall into place. Do not force into place. The base flange must rest on the bomb bore shoulder.

CAUTION: Signals must not be swollen or deformed in any manner. The primer must be flush or slightly below the base of the cartridge. Signal cartridges that are deformed in any way shall not be used.

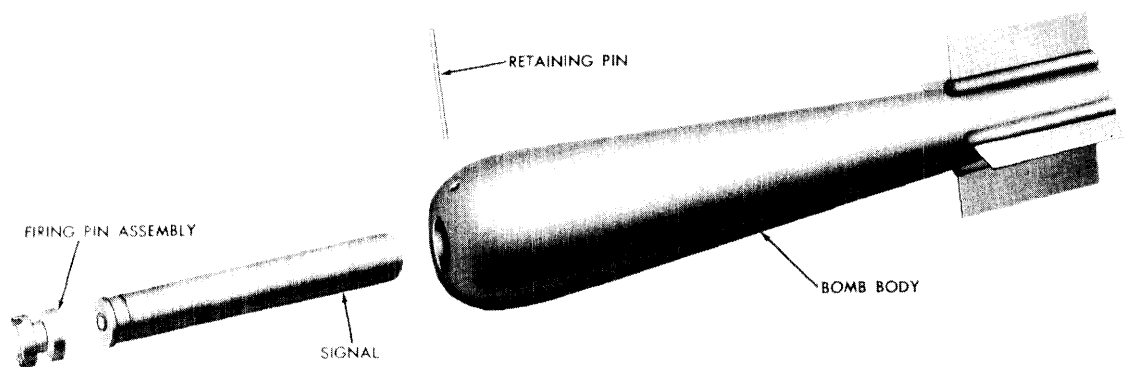

Figure 10.6—13-lb Miniature Practice Bomb Mk 19 Mod 1, Exploded View.

5. Carefully insert pin assembly with the firing pin end toward the signal.

CAUTION: Firing pin assembly must drop into place of its own weight. Do not apply pressure to force the firing pin assembly into the bomb, because the assembly may collapse and detonate the signal.

6. Rotate firing pin assembly so that the two notches in the lip line up with the two pin holes in the bomb nose. Do not exert pressure on the firing pin during this operation.

7. Insert the retaining pin through the nose holes and the recesses in the firing pin assembly.

8. Peen lead over end of retaining pin to hold pin in place, or use two patches of tape over pin holes to retain the pin.

CAUTION: Only sufficient peening should be done to retain the pin, yet permit its withdrawal if it becomes necessary to unload the practice bomb.

Assembly Using Fluorescein Signal Mk 5

1. Remove required number of bombs and signals from their packings. Miniature practice bombs are shipped from the manufacturer with a firing pin assembly installed and a retaining pin through the nose end.

2. Remove retaining pin and firing pin assembly from the nose of the bomb as described in the procedure for installing Signal AN-Mk 4.

3. Secure signal in the bomb by replacing retaining pin.

4. Peen lead over end of retaining pin to hold pin in place, or use two patches of tape over pin holes to retain pin.

CAUTION: Only sufficient peening should be done to retain pin, yet permit its withdrawal if it becomes necessary to unload the practice bomb.

5. Retain discarded firing pin assemblies as spares, or return them to the nearest supply point.

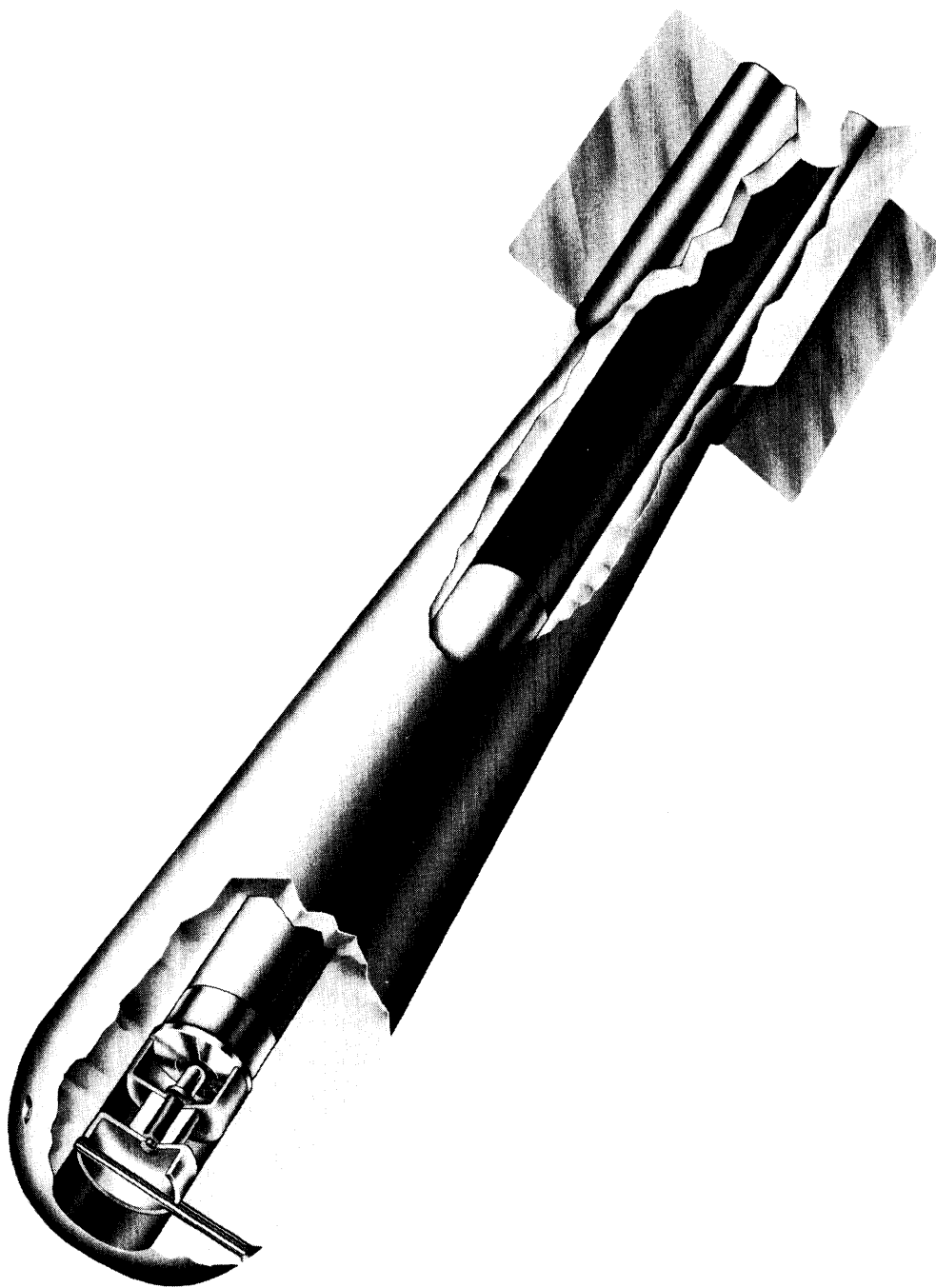

Figure 10.7—13-lb Miniature Practice Bomb Mk 19 Mod 1, Cutaway View.

Chapter 11
PRACTICE BOMBS

Section 11.1—General

Section 11.2—25-lb Practice Bomb Mk 76 Mod 0

Section 11.3—100-lb Practice Bomb Mk 15 Mods 2 and 3

Section 11.4—100-lb Practice Bomb Mk 15 Mod 4

Section 11.5—500-lb Practice Bomb Mk 65 Mod 0

Section 11.6—1000-lb Practice Bomb Mk 66 Mod 0

Section 11.7—1000-lb Practice Bomb Mk 88 Mod 0

Section 11.8—2000-lb Practice Bomb Mk 67 Mod 0

Section 11.9 250 lb. Practice Bomb Mk 86 Mod 0

Page 191, add

"Section 11.10-56-lb Practice Bomb Mk 89 Mod 0

Section 11.11-500-lb Practice Bomb Mk 87 Mod 0

Section 11.12-25-lb Practice Bomb Mk 76 Mod 1

Section 11.13-25-lb Practice Bomb Mk 76 Mod 2

Section 11.14-25-lb Practice Bomb Mk 76 Mod 3 "

Chapter 11

PRACTICE BOMBS

250 lb. Practice Bomb Mk 86 Mod 0
Section 11.1—General

Description

Practice bombs (P), figure 11.1, are similar to service bombs in appearance and flight characteristics. Fin assemblies usually are the same in basic construction as the fins used in service bombs. A few minor changes are some times made to the fin assemblies to accommodate signals and facilitate installation on the bomb body. The differences are in larger fin sleeve openings and additional holes for securing the fin to the bomb body.

Practice bombs may use signals and fuzes, or a combination thereof, depending upon the action desired and the type of practice bomb. Wet sand, dry sand, and water are common fillers used to simulate weights of service bombs.

The 25-lb Practice Bomb Mk 76 Mod 0 differs from the larger practice bombs because it has a cast-metal body. Similar to a miniature practice bomb, it uses a firing pin assembly, retaining pin, and Signal AN-Mk 4.

Usage

Practice bombs are used for the training of bombing crews in marksmanship. These bombs may use signals which produce a puff of smoke. The detonation of the signal makes it possible to spot the impact location of the bomb. The use of practice bombs instead of live bombs is an added safety feature for the training of crews.

Practice Bombs

- 25-lb Practice Bomb Mk 76 Mod 0
- 100-lb Practice Bomb Mk 15 Mods 2, 3, and 4
- 500-lb Practice Bomb Mk 65 Mod 0
- 1000-lb Practice Bomb Mk 66 Mod 0
- 1000-lb Practice Bomb Mk 88 Mod 0
- 2000-lb Practice Bomb Mk 67 Mod 0

Fuzes and Signals

Practice bombs use fuzes and signals. The following fuzes and signals are used with practice bombs:

- Fuzes:
 - Mk 247 Mod 0
- Signals:
 - AN-Mk 4
 - Mk 6 Mod 0
 - Mk 7 Mod 0

Markings

Practice bombs are identified by standard nomenclature located on the bomb body. Nomenclature may be stenciled in white or black letters. Small practice bombs may have standard nomenclature stamped in the casing. Bomb bodies and their components usually are black in color. Bomb components are identified completely by standard nomenclature and ammunition lot number stenciled in black on all packings.

Suspension

Practice bombs can be suspended by either one or two lugs that are attached to the bomb body. Suspension lugs are located for 14 inch lug spacing. Hoisting of the heavier practice bombs is facilitated by adjustable screw-type hoisting lugs. One or more may be used for various hoisting conditions.

Safety Precautions

Practice bombs and their components are shipped separately and are assembled in the field to form a complete round. Preparing practice bombs for flight requires extreme care because a mis-step may prove fatal. Check and double-check each action, and be absolutely sure of the assembly procedure.

Page 193, add under Practice Bombs:
 "50-lb Practice Bomb Mk 89 Mod 0
 500-lb Practice Bomb Mk 87 Mod 0
 25-lb Practice Bomb Mk 76 Mods 1, 2, and 3"

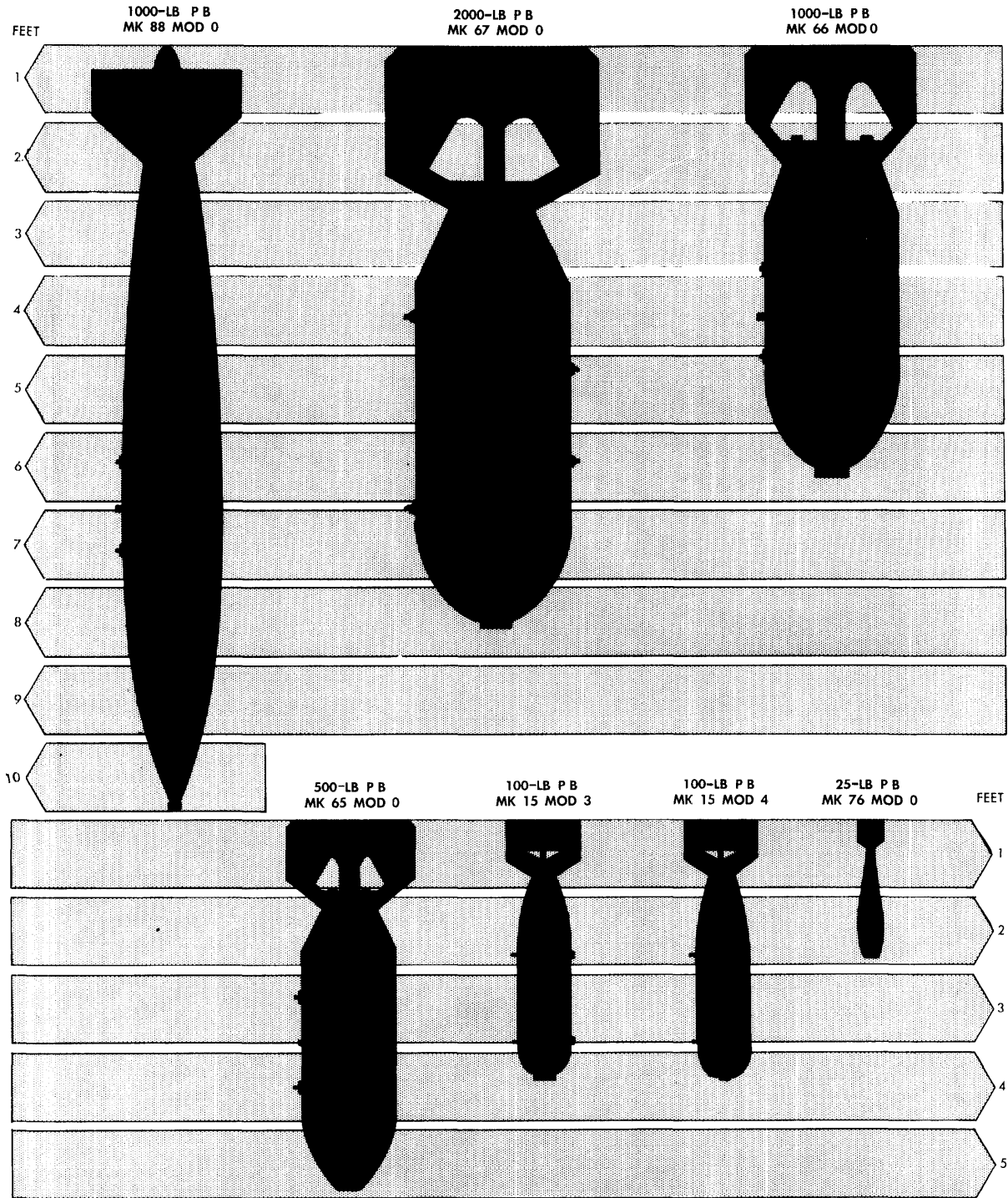

Figure 11.1—Practice Bombs, Comparative Size.

Safety Precautions To Be Observed

1. Signals, fuzes, and bombs shall not be unpacked in advance of requirements and shall be returned to their original packings, if not used.
2. Signals must not be swollen or deformed in any manner. The primer must be flush or slightly below the base of the cartridge. Deformed signal cartridges shall not be used.
3. Guard the signals against dropping or bumping at all times, to prevent accidental detonation.
4. Be sure firing pin cup is not deformed and that the firing-pin point is below the lip of the cup.
5. Check the bore of the bomb, bore must be smooth and clean, and not damaged in any way.
6. Do not force signal into bomb, it must fall gently into place by its own weight.
7. Do not apply pressure to firing pin assembly; it may collapse and fire the signal.
8. Do not bend ends of the cotter pin at right angles, or strike the ends to bend into position.
9. When handling practice bombs loaded with a signal, be extremely careful not to drop or jar the bomb; a sudden impact may detonate the signal.
10. Do not point either end of the bomb blast tube toward other personnel.
11. During loading operations, loaders must not have their heads in line with the nose or tail end of the bomb blast tube.
12. Do not strike bomb nose against an

object to loosen the firing pin assembly or signal cartridge.

13. Protect Practice Bomb Signal AN--Mk 4 during stowage from moisture, excessive heat, excessive motion, and vibration.

14. Any accidentally armed fuze, fully or partially armed, must be handled by authorized personnel only.

15. Guard fuzes against dropping or bumping at all times, to prevent accidental detonation.

16. Never allow primers to drop or strike an object; they are extremely sensitive and rough handling may explode them.

17. Never remove safety cotter pins or car seals from fuzes prematurely.

18. Screw fuzes into bomb, ~~HANDTIGHT-ONLY~~. Never use a tool, unless authorized. Tools may distort fuzes causing premature detonation.

19. Replace all safety cotter pins before defuzing a bomb.

20. Handle and install arming vanes of fuzes with care to prevent distortion of blades and the possible malfunction of both fuze and bomb.

21. Do not use a fin assembly if it cannot be secured to the bomb properly. If the fin assembly is loose and turns on the bomb, it will pull the arming wire from the signal or fuze.

22. Never use a defective arming wire (one with kinks, twists, or burrs).

23. Practice bomb signals should be stowed in a dry, ventilated location out of the direct rays of the sun.

Section 11.2—25-lb Practice Bomb Mk 76 Mod 0

Description

The 25-lb Practice Bomb Mk 76 Mod 0, figure 11.2, has an elongated, teardrop-shaped bomb body. The fin assembly is composed of four fin blades and a shroud welded to a center tube. A conical section covers the center tube and is threaded to the body section. The two sections are staked together to prevent unscrewing. The two sections are staked together to prevent unscrewing. A cotter pin is inserted through the nose of the bomb to retain the firing pin assembly and signal.

The firing pin assembly fires the signal which is seated in the bore of the body section. Smoke produced from the detonated signal is discharged rearward through the tube of the fin assembly.

A single suspension lug is threaded into the bomb body and cemented in place. Early models of this bomb have a suspension lug with a small opening which precludes use of the bomb on Shackle Mk 8 and Mods or Rack Type Aero 14A. Later models have lugs with a larger opening which permits the use of the bomb on these racks and shackles. Lugs on early model bombs may be replaced by the lug with the larger opening. Activities may obtain the larger lug by ordering Ammunition Stock Recording System Code 307140-A. The threads in the bomb body should be cleaned after removing the smaller lug. The larger lug should be cemented in position when it is installed in the bomb body by applying glycerine-litharge cement to the threads.

An overall black color is applied to the complete bomb. Permanent identifying nomenclature is stenciled on the body of the 25-lb practice bomb.

Physical Characteristics

- Weight of assembled bomb with signal:
 - Loaded with Signal
 - AN-Mk 4 23.8 lbs
- Weight of signal:
 - Signal AN-Mk 4 2 oz

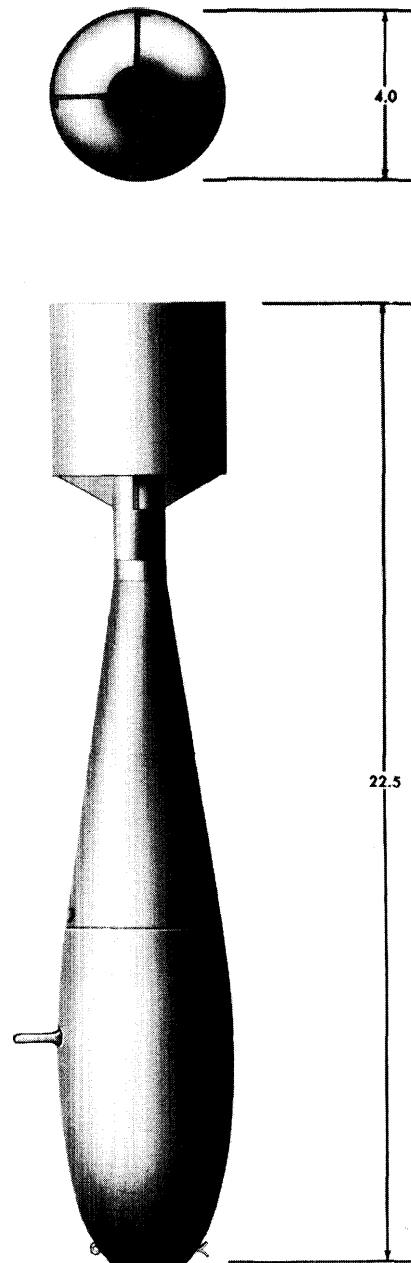

Figure 11.2—25-lb Practice Bomb Mk 76 Mod 0.

Dimensions:

Length or height of complete bomb	22.5 inches
Length of bomb body	8.0 inches
Diameter	4.0 inches
Fin span	4.0 inches
Fin length	14.5 inches

Suspension:

Single suspension lug-- Center of gravity

Components of a Complete Round (Figures 11.3 and 11.4)

Bomb body assembly (including):

- Bomb body
- Cotter pin
- Firing Pin Mk 1 Mod 0

Signal:

AN-Mk 4

Assembly

CAUTION: Signals and bombs shall not be unpacked in advance of requirements. If unpacked and not used, return them to their original packings.

Assembly Using Signal AN-Mk 4

1. Remove required number of bombs and signals from their packings. Practice Bomb

Mk 76 is shipped from the manufacturer with a firing pin assembly installed and with a retaining cotter pin through the nose end.

2. Remove cotter pin and firing pin assembly from nose of bomb.

CAUTION: Firing pin assemblies must fit loosely and not bind when dropped into position. Inspect firing pin assembly for damage. Be sure firing pin cup is not deformed and that the firing-pin point is below the lip of its cup. Check bore through center of bomb; bore must be smooth and clean, and not damaged in any way.

3. With the firing pin assembly removed, place bomb in a vertical position with the nose end up.

4. Insert signal into bomb, primer end up, and let it gently fall into place. Do not force into place. The base flange of the signal cartridge must rest on the bomb bore shoulder.

CAUTION: Signals must not be swollen or deformed in any manner. The primer must be flush or slightly below the base of the cartridge. Signal cartridges that are deformed in any way shall not be used.

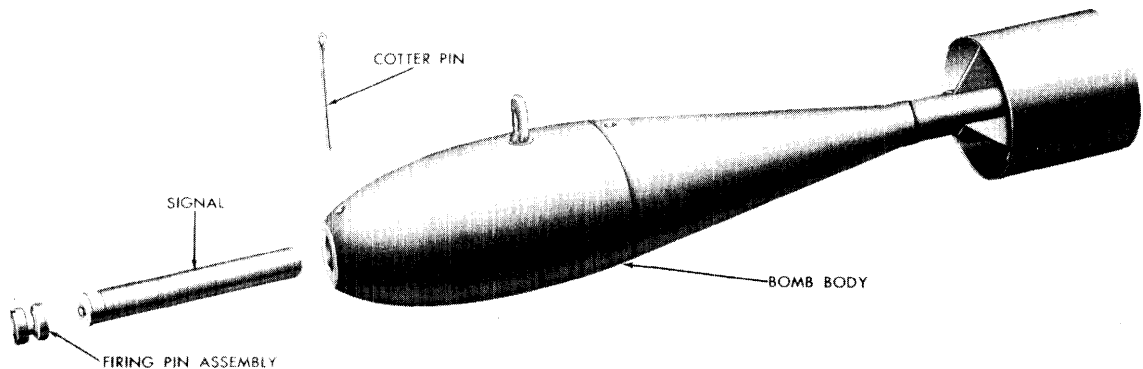

Figure 11.3—25-lb Practice Bomb Mk 76 Mod 0, Exploded View.

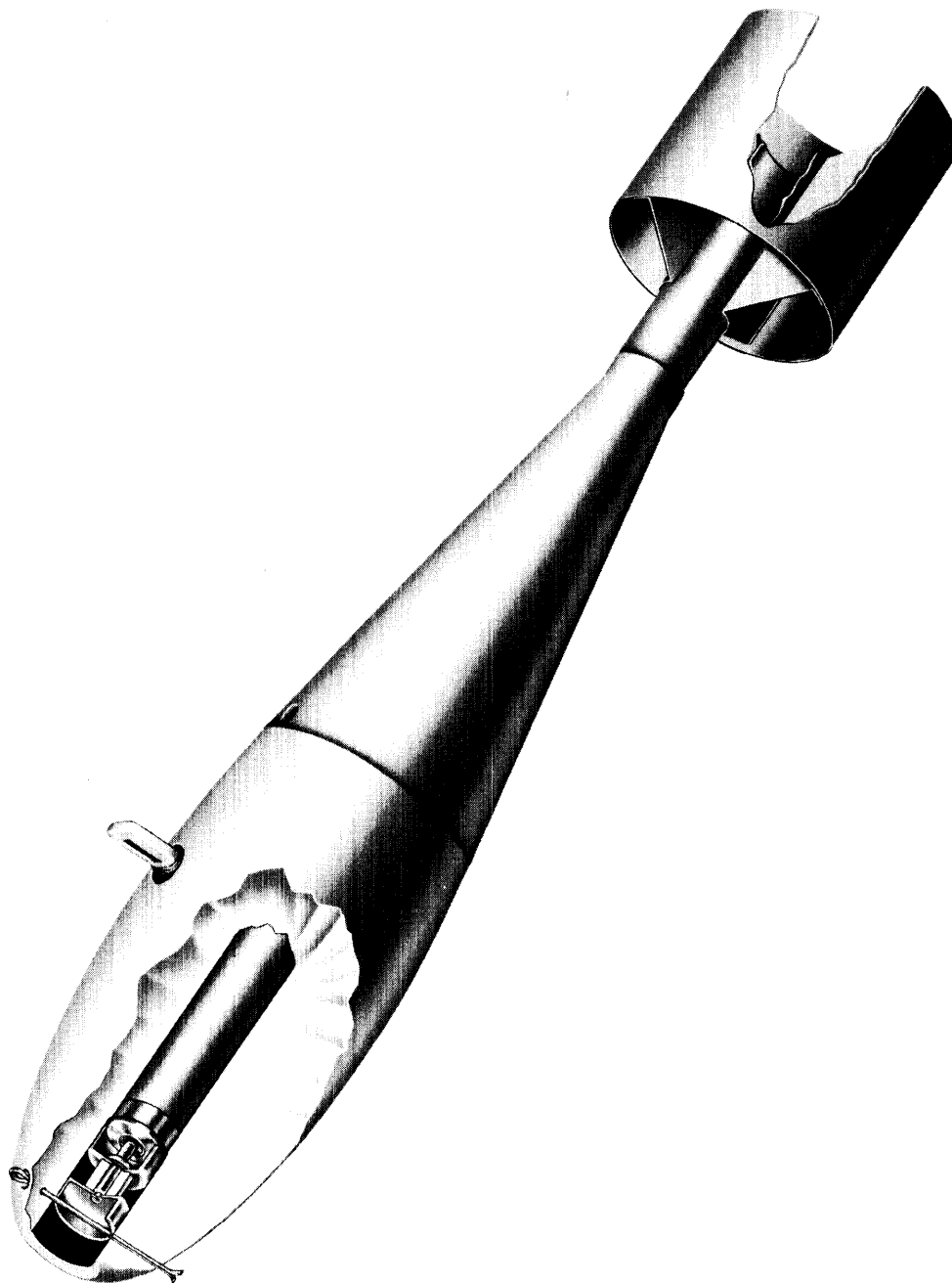

Figure 11.4—25-lb Practice Bomb Mk 76 Mod 0, Cutaway View.

5. Carefully insert firing pin assembly with firing pin end toward the signal.

CAUTION: Firing pin assembly must drop into place under its own weight. Do not apply pressure to force the firing pin assembly into the bomb because the assembly may collapse and fire the signal.

6. Rotate firing pin assembly so that the two notches in the lip line up with the two pin

holes in the bomb nose. Do not apply pressure to firing pin during this operation.

7. Insert cotter pin through the nose holes and the recesses in the firing pin assembly.

8. Spread ends of cotter pin sufficiently with a screwdriver to retain it in the bomb.

CAUTION: Do not bend the ends of the cotter pin at a right angle to the axis of the cotter pin, or strike the ends to bend the cotter pin into position.

Section 11.3—100-lb Practice Bomb Mk 15 Mods 2 and 3

Description

The 100-lb Practice Bomb Mk 15 Mod 3, figure 11.5, is a light-cased, cylindrical bomb with a round nose. A flat-nose attachment fits over the round bomb nose to prevent ricochet when used for antisubmarine bombing practice. This nose piece is secured in place by the filler cap which threads onto the nose end of the bomb. A box-type fin assembly, consisting of four metal vanes attached to a cone, is welded to the aft end of the bomb.

Practice Bomb Signal Mk 7 Mod 0 and Fuze Mk 247 Mod 0 (as a unit) are seated in the aft end of the fin assembly and secured in place with a locking plate and two wing nuts.

The 100-lb Bomb Mk 15 Mod 3 is used for all types of bombing practice. The capacity of this bomb is 4.68 gallons of water or 74.9 pounds of wet sand. During freezing conditions, antifreeze must be added to prevent expansion and bursting of the bomb case due to freezing of the filler.

Identifying nomenclature is painted in 1/2-inch white letters on the black-colored bomb. Removable suspension bands may be adjusted for 2-point suspension (14 inches apart), or single suspension (at the center of gravity).

Difference Between Bombs Mk 15 Mod 2 and Mk 15 Mod 3

The difference between Practice Bomb Mk 15 Mod 2 and Practice Bomb Mk 15 Mod 3 is in the signal and fuze. The Mod 3 can be equipped with Signal Mk 7 Mod 0 and Fuze Mk 247 Mod 0. Mod 2 uses neither signal nor fuze. In all other respects, the two models are similar.

Mk 15 Mod 4 differs appreciably from both Mods 2 and 3. For information on Mk 15 Mod 4, refer to section 11.4.

Physical Characteristics of Practice Bomb Mk 15 Mod 3

- Weight of assembled fuzeed bomb:
- Loaded with wet sand... 101.0 lbs
- Weight of wet-sand filler:
- Wet sand..... 74.9 lbs

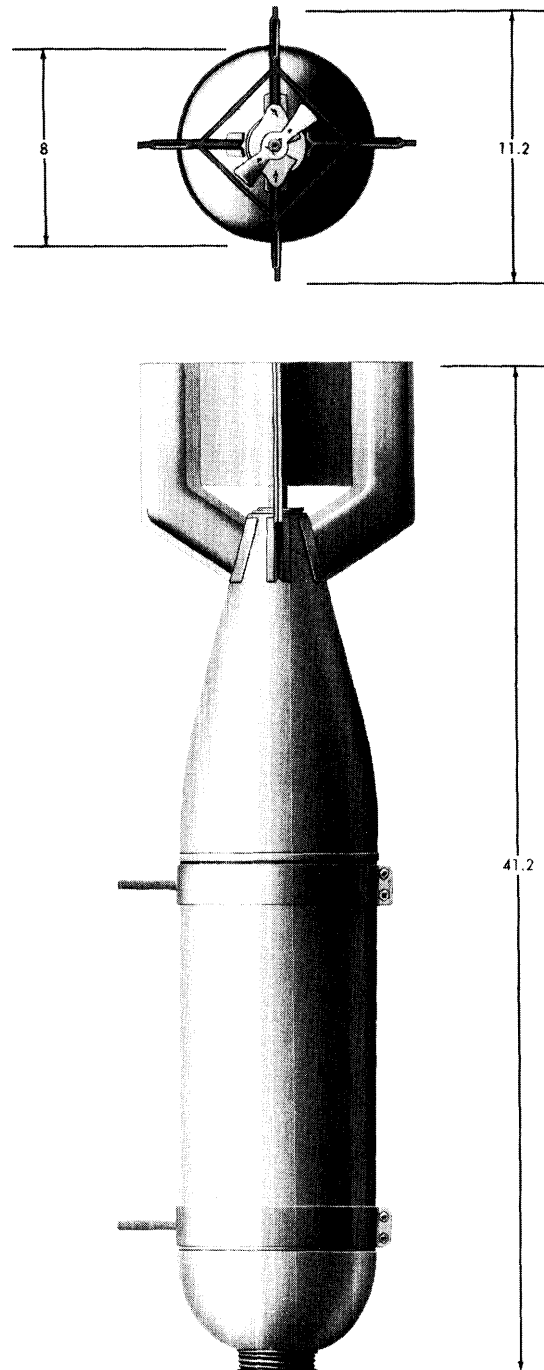

Figure 11.5—100-lb Practice Bomb Mk 15 Mod 3.

Dimensions:

- Length or height of complete bomb 41.2 inches
- Length of bomb body 25.1 inches
- Diameter 8.0 inches
- Fin span 11.24 inches
- Fin length 20 inches

Suspension:

- Two suspension bands, 14 inches c to c or
- One suspension band - Center of gravity

Components of a Complete Round (Figures 11.6 and 11.7)

Bomb body assembly (including):

- Bomb body (with fin assembly integral)
- Filler cap
- Locking plate, wing nuts, and lock washers
- Flat-nose attachment
- Suspension bands (2)
- Signal Mk 7 Mod 0
- Fuze Mk 247 Mod 0
- Arming Wire Assembly Mk 1
- Fahnestock clips

Assembly

CAUTION: Signals, fuzes, and bombs shall not be unpacked in advance of requirements. If unpacked and not

used, return them to their original packings. Practice bomb signals must be stowed in a dry, ventilated location out of the direct rays of the sun.

1. Remove bomb assembly from crate. CAUTION: Inspect for damage (cracked weldments, etc.) which might cause leaks in the bomb casing.
2. Remove filler cap from bomb nose.
3. Fill bomb with required amount of water or wet sand at loading base. During freezing conditions, add antifreeze.
4. Replace filler cap and thread on, hand-tight. If bomb is to be used for antisubmarine practice, place flat-nose attachment over bomb nose before replacing filler cap.
5. Adjust for 14-inch suspension by loosening and moving suspension bands. For single suspension, remove one band, and loosen the other band, moving it to the center of gravity. Align the bands so that the tail fins will clear the aircraft structure and ground, when bomb is installed. Secure bands in place by tightening band securing screws.
6. Remove required number of signals, fuzes, and arming wire assemblies from their containers.

CAUTION: If containers are punctured, split, or if the seal is broken in any way, the fuzes contained therein

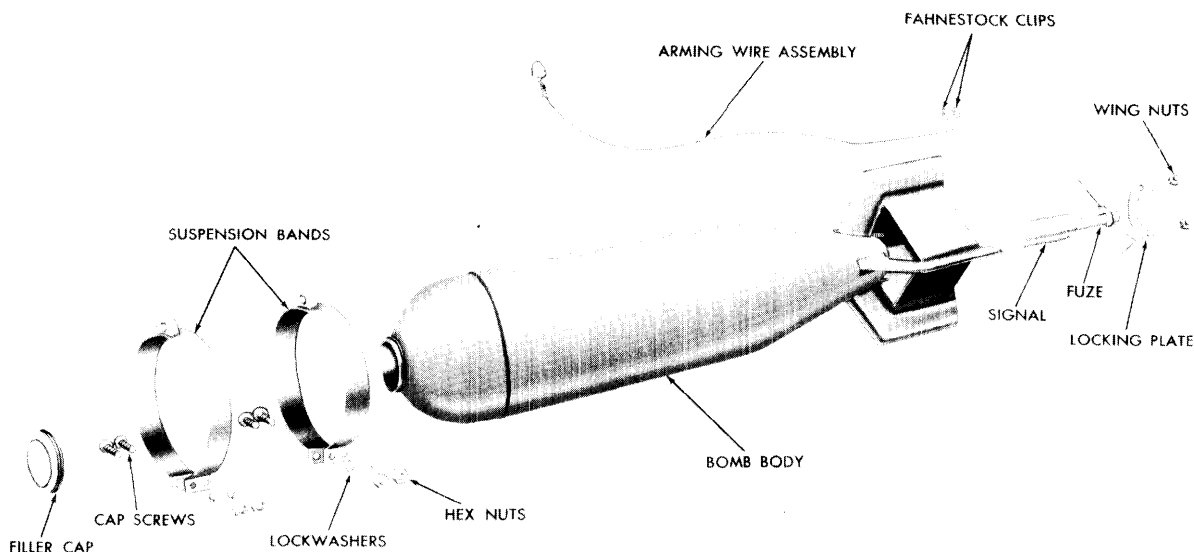

Figure 11.6—100-lb Practice Bomb Mk 15 Mod 3, Exploded View.

shall be considered unserviceable. This does not apply to fuzes repacked in the field and resealed with adhesive tape for temporary protection. These fuzes should be examined carefully for serviceability.

7. A combination of Fuze Mk 247 Mod 0 and Signal Mk 7 Mod 0 is used for the 100-lb Practice Bomb Mk 15 Mod 3.

8. Remove wing nuts, lock washers, and locking plate from the two studs beside the opening in the aft end of the bomb. For

detailed information on fuzing and defuzing, refer to OP 988 (First Revision).

9. After installation of signal and fuze, install bomb in accordance with type of rack in use and securely lock in place. If bomb bay does not provide enough space for fuzing, fuzing shall be done prior to hoisting bomb into place on the rack.

CAUTION: Do not remove safety cotter pin until bomb is in place in the aircraft and the arming wire is installed completely.

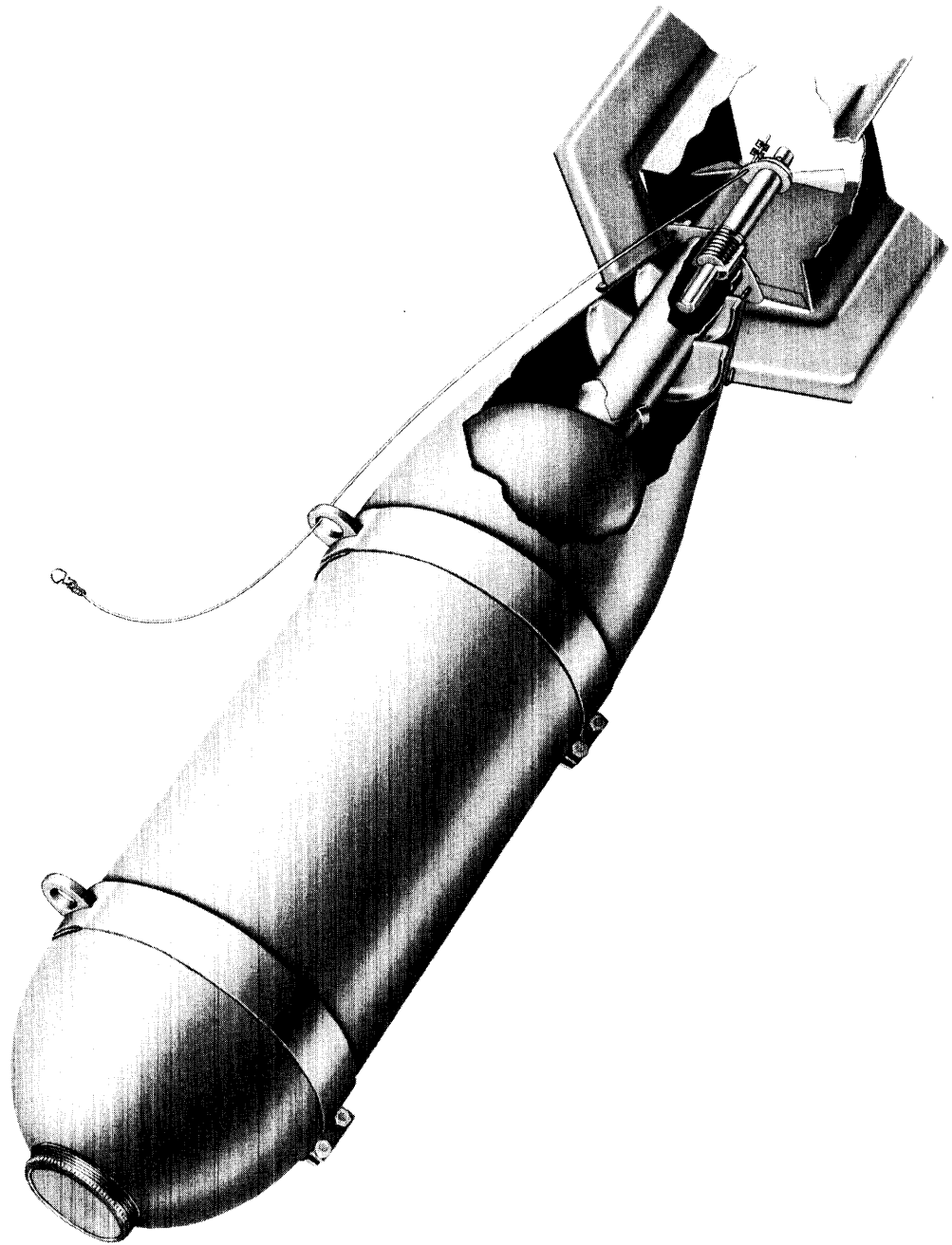

Figure 11.7—100-lb Practice Bomb Mk 15 Mod 3, Cutaway View.

Section 11.4—100-lb Practice Bomb Mk 15 Mod 4

Description

The 100-lb Practice Bomb Mk 15 Mod 4, figure 11.8, is a light-cased, cylindrical bomb with a round nose and integral box-type fin and fin cone. A flash tube, extending from the nose to the fin cone, holds a firing pin and Signal AN-Mk 4.

To prevent ricochet when the bomb is dropped on underwater targets, a flat-nose attachment is provided. The attachment fits snugly over the round nose of the bomb and is secured with a locknut threaded over the projecting end of the flash tube.

A filling hole is located off-center on the round nose of the bomb. When the flat-nose attachment is used, the filling hole and filler cap are hidden completely. The bomb may be filled with either 76 pounds of wet sand or 39 pounds (about 4½ gallons) of water. If the bomb will be subjected to freezing conditions, antifreeze must be added to prevent expansion and rupturing of the bomb case due to freezing of the filler.

Two suspension lugs are welded to the bomb case 14 inches apart. The bomb is painted black; identifying nomenclature is stenciled in white on the bomb casing.

Physical Characteristics of Practice Bomb Mk 15 Mod 4

- Weight of assembled fuzed bomb:
 - Loaded with wet sand... 97.0 lbs
 - Loaded with water... 60.0 lbs
- Weight of filler:
 - Wet sand..... 76.0 lbs
 - Water..... 39.0 lbs

- Dimensions:
 - Length or height of complete bomb..... 41.54 inches
 - Diameter..... 8.0 inches
 - Fin span..... 11.24 inches

- Suspension:
 - Two suspension lugs... 14 inches c to c

Components of a Complete Round (Figures 11.9 and 11.10)

- Bomb body (with integral fin assembly)
- Filler cap

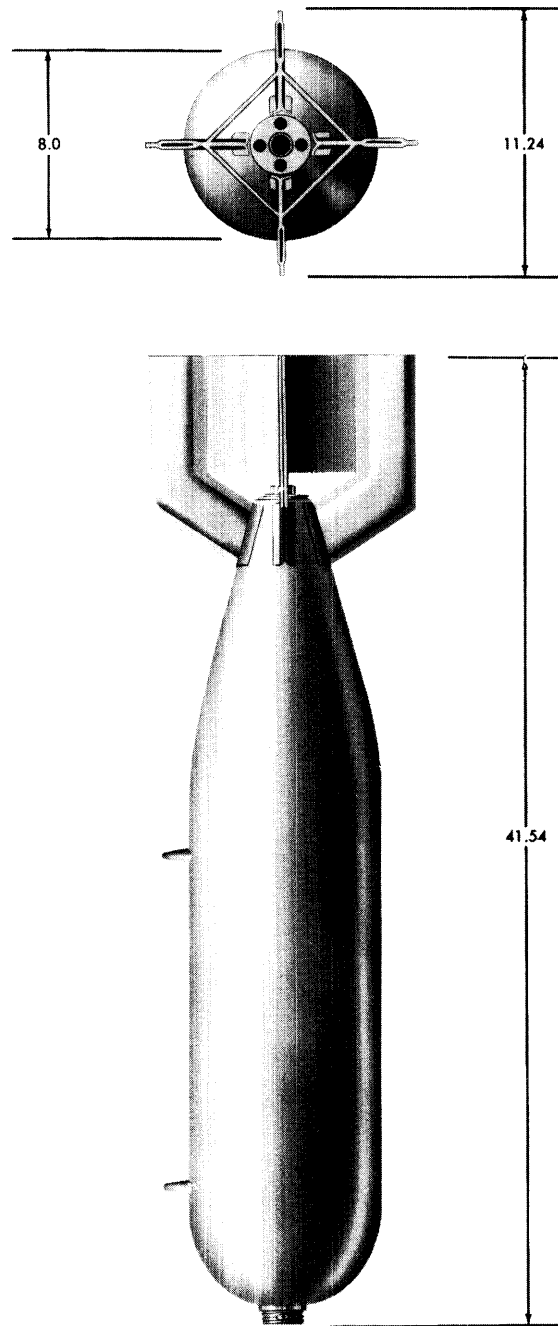

Figure 11.8—100-lb Practice Bomb Mk 15 Mod 4.

Firing Pin Mk 1 Mod 0
 Cotter pin
 Flat-nose attachment
 Locknut (for use with flat-nose attachment)
 Signal AN-Mk 4 (or Mods)

Assembly

CAUTION: Signals and bombs shall not be unpacked in advance of requirements. If unpacked and not used, return them to their original packings.

1. Remove the bomb from its packing crate.

CAUTION: Inspect for damaged seams, broken weldments, and deformed parts that might cause leaks in the bomb body or weaken the suspension lugs or their attachment to the bomb case.

2. Unthread flat-nose attachment locknut and remove flat-nose attachment.

3. Use a suitable spanner wrench to twist and remove filler cap from the filling hole. Inspect gasket to be sure that it is not damaged. If damaged, it should be replaced.

4. Fill bomb with required amount of wet sand or water; during freezing conditions, add antifreeze.

5. Replace filler cap. Twist on with spanner wrench, until locked in place.

6. If bomb is to be used against underwater targets, replace flat-nose attachment and lock in place with locknut.

7. Remove cotter pin and firing pin from the nose end of the bomb flash tube.

CAUTION: Inspect firing pin assembly for damage. Be sure firing pin cup is not deformed and that the firing-pin point is below the lip of its cup. Check flash-tube bore through the center of the bomb; the bore must be free from obstructions and not damaged in any way.

8. With bomb supported in a vertical position (nose upward), insert the signal, primer end up, into the flash tube. Let the signal fall in place; **DO NOT FORCE SIGNAL INTO PLACE.** The base flange of the signal should rest on the flash tube shoulder located about $1\frac{1}{8}$ inch in from the nose end of the tube.

CAUTION: The signal must not be swollen or deformed in any manner. The primer must be flush with or slightly below the base of the cartridge. Signal cartridges that are deformed in any way shall not be used.

9. Carefully insert the firing pin assembly with the firing pin end facing the signal.

CAUTION: The firing pin assembly must drop into place under its own

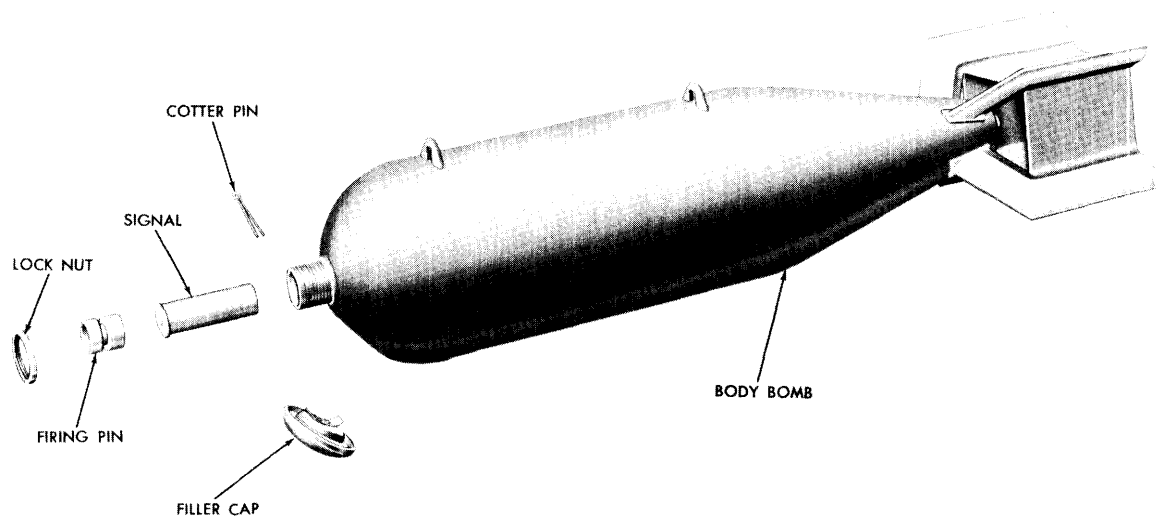

Figure 11.9—100-lb Practice Bomb Mk 15 Mod 4, Exploded View.

weight. Do not apply pressure to force the firing pin assembly into place because the assembly may collapse and fire the signal.

10. Rotate firing pin assembly so that the two notches in the lip line up with the two pin holes in the bomb nose. Do not apply pressure to firing pin during this operation.

11. Insert the cotter pin through the pin holes in the nose of the flash tube, passing

through the notches in the forward cup of the firing pin assembly.

12. Spread the ends of the cotter pin sufficiently with a screwdriver to retain it in the bomb.

CAUTION: Do not bend the ends of the cotter pin to form right angles to the cotter pin axis. Do not strike the ends of the cotter pin to bend them into position.

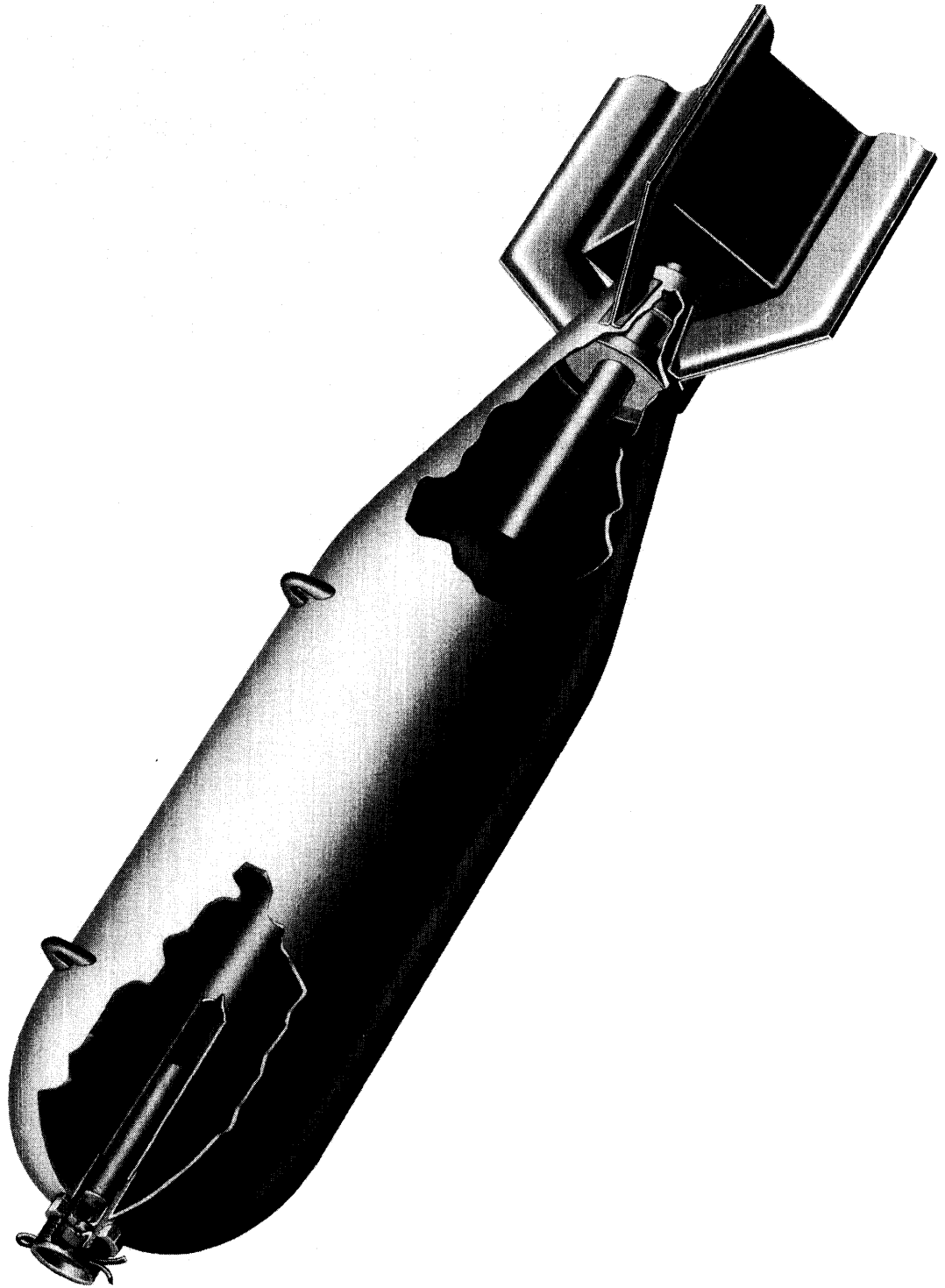

Figure 11.10—100-lb Practice Bomb Mk 15 Mod 4, Cutaway View.

Section 11.5—500-lb Practice Bomb Mk 65 Mod 0

Description

The 500-lb Practice Bomb Mk 65 Mod 0, figure 11.11, is constructed from welded sheet-steel sections. This light-cased bomb has an ogival nose section, a cylindrical center section, and a tapered aft end. A box-type fin is secured to the aft end by hex-head bolts. A nose-filler cap and gasket are threaded into the nose end of the bomb and safety-wired to the nose bracket.

Practice Bomb Signal Mk 6 Mod 0 and Fuze Mk 247 Mod 0 (as a unit) are seated in a recess in the aft end of the bomb and are secured to the fin assembly by the signal bracket. The bomb is filled with 395 pounds of wet sand or 200.6 pounds of water. During freezing conditions, antifreeze is added to the water.

Identifying nomenclature is stenciled on the bomb casing and its components. Double suspension lugs are welded to the bomb body. A hoisting lug may be threaded into one of seven recesses on the periphery of the bomb body at the center of gravity.

Physical Characteristics

Weight of assembled fuzed bomb:

- Loaded with wet sand..... 443.2 lbs
- Loaded with water..... 248.8 lbs

Weight of filler:

- Wet sand..... 395.0 lbs
- Water..... 200.6 lbs

Weight of fin assembly:

- Box fin assembly..... 12.0 lbs

Dimensions:

- Length or height of complete bomb..... 56.6 inches
- Length of bomb body..... 44.6 inches
- Diameter..... 14.0 inches
- Fin span..... 19.0 inches
- Fin length..... 13.9 inches

Suspension:

- Two suspension lugs..... 14 inches c to c
- One or two threaded hoisting lugs

Components of a Complete Round (Figures 11.12 and 11.13)

Bomb body assembly (including):

- Bomb body
- Nose filler cap, gasket, and safety wire

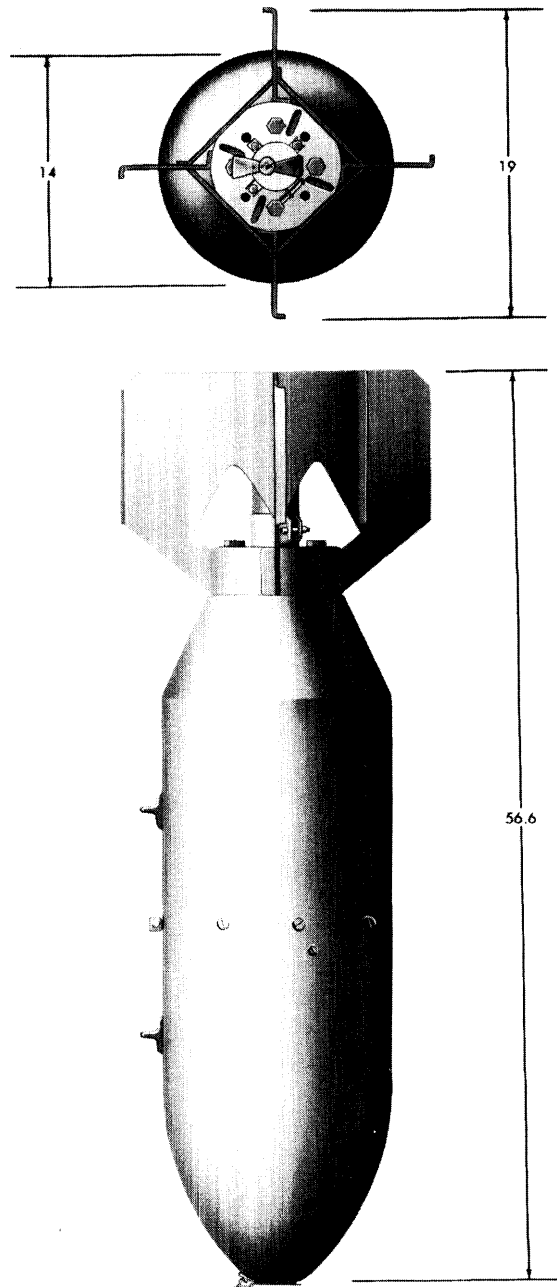

Figure 11.11—500-lb Practice Bomb Mk 65 Mod 0.

Box fin assembly
 Hoisting lugs (2)
 Signal Mk 6 Mod 0
 Fuze Mk 247 Mod 0
 Arming Wire Assembly Mk 1
 Fahnestock clips

Assembly

CAUTION: Signals, fuzes, and bombs shall not be unpacked in advance of requirements. If unpacked and not used, return them to their original packings. Practice bomb signals should be stowed in a dry, ventilated location out of the direct rays of the sun.

1. Remove bomb body from stowage.

CAUTION: Inspect for damage (broken weldments, etc.) which may cause leaks in the bomb casing. Inspect for damaged lugs or their attachment to the bomb body.

2. Remove shipping wire from nose plug, and unthread plug. Fill with required amount of wet sand or water. (During freezing conditions, add antifreeze.) Replace nose plug; thread on, handtight. Be sure gasket is installed properly and is not damaged.

3. Remove fin assembly and attachments from shipping crate.

4. Open box containing Practice Bomb Signal Mk 6. Remove practice bomb signal bracket from signal.

5. Fasten signal bracket to fin sleeve by squeezing band ends together, permitting the slots to be slipped under the rivets on the fin sleeve. Bolt signal bracket to fin assembly with the nut, bolt, and lockwashers provided.

6. Depending upon the type of suspension, the holes in the fin assembly base and bomb base should be aligned so that the tail fins will clear the aircraft structure and the ground, when the bomb is installed. Place lockwashers over bolts and insert through holes in fin base and thread into bomb body, securing the fin assembly.

7. Install the cylindrical section of Practice Bomb Signal Mk 6 Mod 0. For detailed information on fuzing and defuzing using Practice Bomb Signal Mk 6 and Fuze Mk 247, refer to OP 988 (First Revision).

8. After installation of signal and fuze, install bomb in accordance with type of rack in use, (use hoisting lugs supplied for various hoisting conditions) and securely lock in place.

CAUTION: Do not remove safety cotter pin until bomb is in place in the aircraft and the arming wire is installed completely.

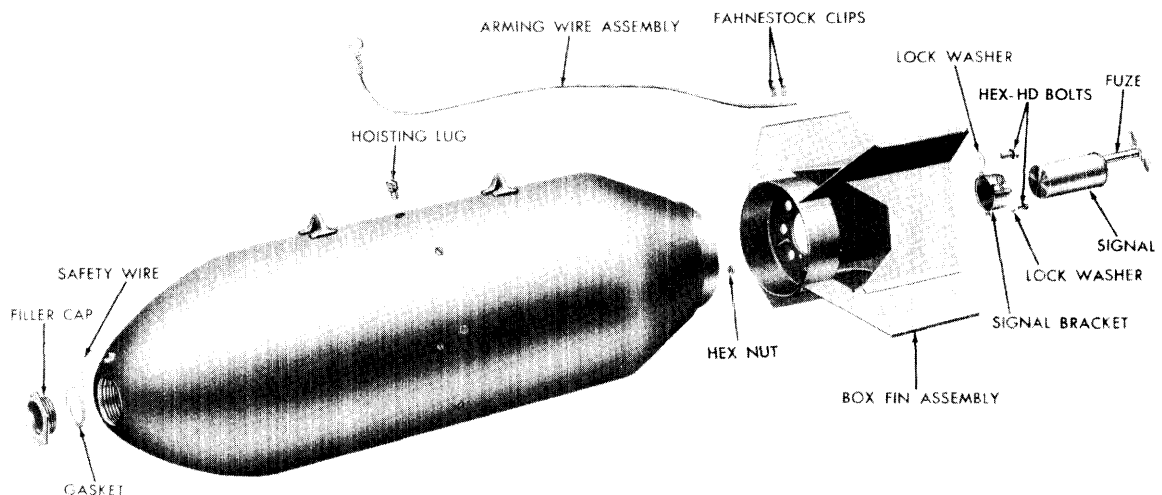

Figure 11.12—500-lb Practice Bomb Mk 65 Mod 0, Exploded View.

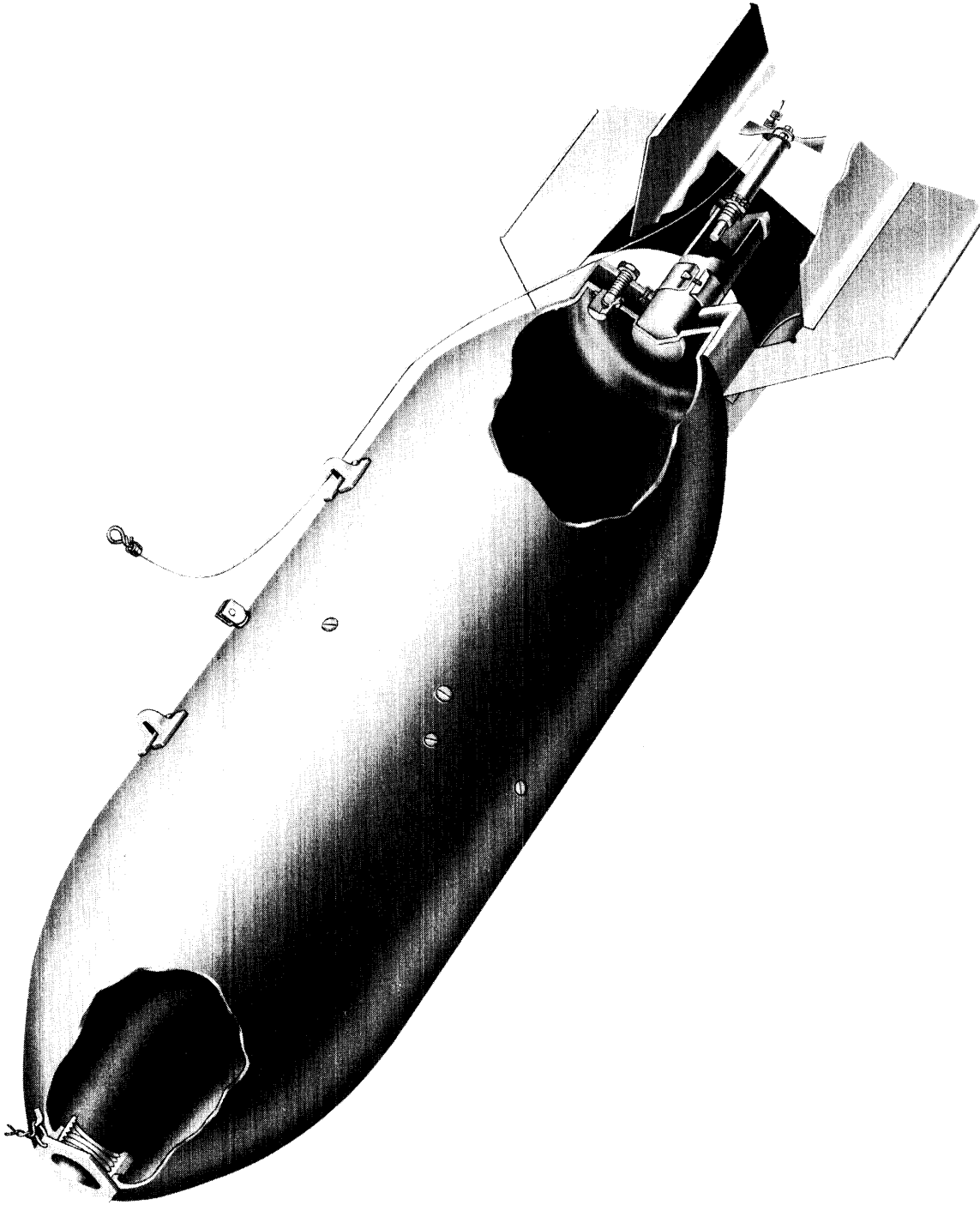

Figure 11.13—500-lb Practice Bomb Mk 65 Mod 0, Cutaway View.

Section 11.6—1000-lb Practice Bomb Mk 66 Mod 0

Description

The 1000-lb Practice Bomb Mk 66 Mod 0, figure 11.14, is constructed of welded sheet-steel sections. This light-cased bomb has an ogival nose, cylindrical center section, and a tapered aft end. A box-type fin is secured to the aft end with hex-head bolts. Mk 66 Mod 0 has a filler cap which threads into the nose end of the bomb and is safety-wired to the nose bracket. Another filler hole is located on the side of the bomb. This hole is capped with a circular plate and gasket which are secured to the bomb case with hex-head bolts. For added rigidity, inside reinforcement strips are welded to the bomb casing.

Practice Bomb Signal Mk 6 Mod 0 is seated in a recess in the aft end of the bomb. A practice signal bracket, supplied with Signal Mk 6 Mod 0, secures the signal to the fin assembly. The bomb is filled with 788.3 pounds of wet sand or 385.3 pounds of water. During freezing conditions, antifreeze is added to the filler.

Double suspension lugs are welded to the bomb body. A hoisting lug may be threaded into one of seven recesses on the periphery of the bomb body. One or two hoisting lugs are used, as needed. Identifying nomenclature is stenciled in ½-inch letters on the bomb body and its components.

Physical Characteristics

- Weight of assembled fuzed bomb:
 - Loaded with wet sand883.5 lbs
 - Loaded with water 480.5 lbs
- Weight of filler:
 - Wet sand 788.3 lbs
 - Water 385.3 lbs
- Weight of fin assembly:
 - Fin assembly 21.0 lbs
- Dimensions:
 - Length or height of complete bomb 66.96 inches
 - Length of bomb body 50.84 inches
 - Diameter 18.63 inches
 - Fin span 25.40 inches
 - Fin length 18.52 inches

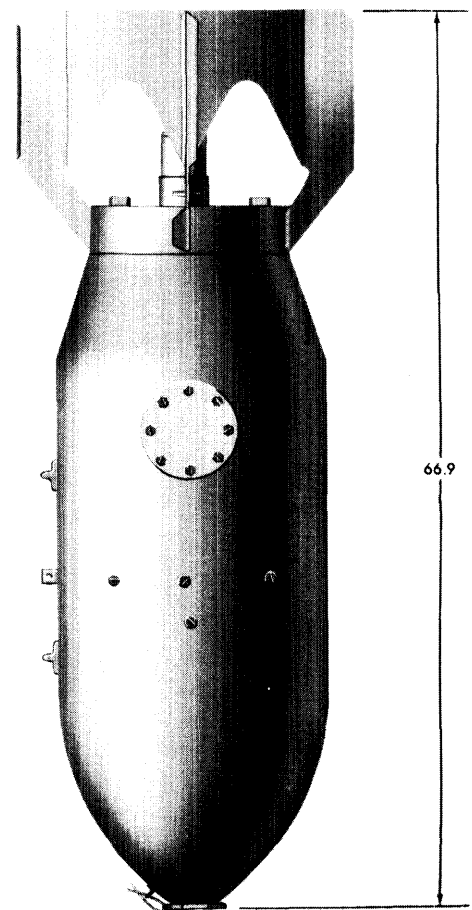
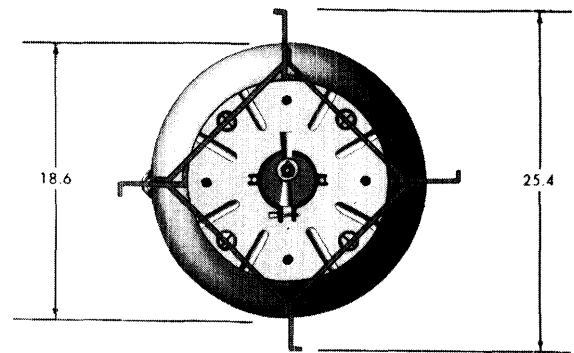

Figure 11.14—1000-lb Practice Bomb Mk 66 Mod 0.

Suspension:

- Two suspension lugs..... 14 inches c to c
- One or two threaded hoisting lugs

Components of a Complete Round (Figures 11.15 and 11.16)

Bomb body assembly, (including):

- Bomb body
- Nose filler cap gasket and safety wire
- Side filling hole cover with eight bolts and washers

Fin assembly with lockwashers and hex-head bolts

- Hoisting lugs (2)
- Signal Mk 6 Mod 0
- Fuze Mk 247 Mod 0
- Arming Wire Assembly Mk 1
- Fahnestock clips

Assembly

CAUTION: Signals, fuzes, and bombs shall not be unpacked in advance of requirements. If unpacked and not used, return them to their original packings. Practice bomb signals should be stowed in a dry, ventilated location out of the direct rays of the sun.

1. Remove bomb body from stowage.

CAUTION: Inspect for damage (broken weldments, etc.) which may cause leaks in the bomb casing. Inspect lugs and their attachment to the bomb body for damage.

2. Remove shipping wire from nose plug and unthread plug; fill bomb with required amount of wet sand or water; replace plug (thread on, handtight). During freezing conditions, add antifreeze. The side filling hole also may be used.

3. Remove fin assembly and attachments from shipping crate.

4. Open box containing Practice Bomb Signal Mk 6. Remove signal bracket from signal.

5. Fasten signal bracket to fin sleeve by squeezing band ends together, permitting the slots to be slipped under the rivets on the fin sleeve. The signal bracket is bolted to the fin assembly with the nut, bolt, and lockwasher provided.

6. Depending upon the type of suspension, the holes in the fin assembly base and bomb base plug should be aligned so that the fins will clear the aircraft structure and the ground, when the bomb is installed. Place lockwashers over bolts, insert bolts through holes of fin sleeve and thread onto bomb body, securing fin assembly.

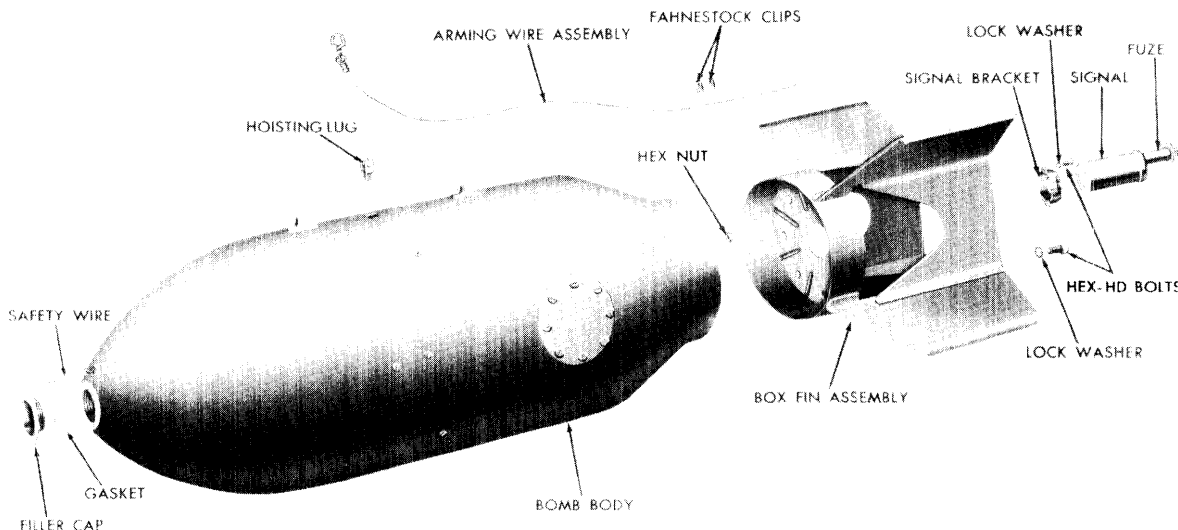

Figure 11.15—1000-lb Practice Bomb Mk 66 Mod 0, Exploded View.

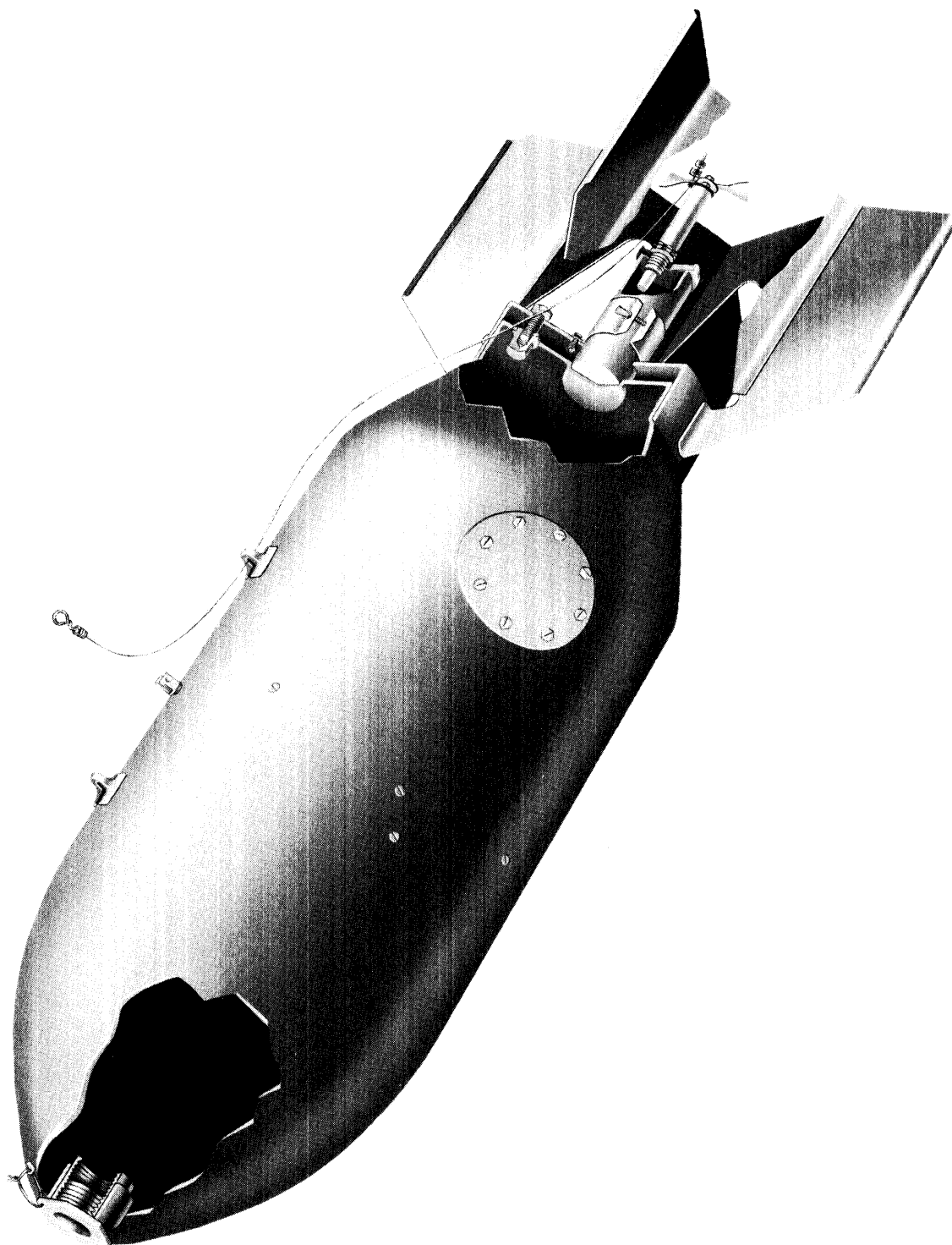

Figure 11.16—1000-lb Practice Bomb Mk 66 Mod 0, Cutaway View.

7. Install cylindrical section of Practice Bomb Signal Mk 6 Mod 0. For detailed information on fuzing and defuzing using Signal Mk 6 and Fuze Mk 247, refer to OP 988 (First Revision).

8. After installation of signal and fuze, install bomb in accordance with type of rack in

use, (use hoisting lugs supplied for various hoisting conditions) and securely lock in place.

CAUTION: Do not remove safety cotter pin until bomb is in place in the aircraft and the arming wire is installed completely.

Section 11.7—1000-lb Practice Bomb Mk 88 Mod 0

Description

The 1000-lb Practice Bomb Mk 88 Mod 0, figure 11.17, is a low-drag bomb of the same size and shape as the Mk 83 series of low-drag general purpose bombs. It has a sharp nose and a conically tapered aft end. Two filler holes are located on the upper side and are capped with filler covers. Four fin blades are assembled perpendicularly to the bomb axis and are set forward from the rear end of the bomb.

The 1000-lb Practice Bomb Mk 88 Mod 0 is of thin-case construction with internal reinforcement for the sway brace and ejection areas. To provide rigidity, bulkheads and channel reinforcements are used on the inside of the bomb casing.

Signal AN-Mk 4 is used with the 1000-lb Practice Bomb Mk 88 Mod 0. A blast tube extends from the nose to the aft end of the bomb and allows for exit of the signal smoke when fired. The firing pin assembly and signal are held in place inside the blast tube by a retaining cotter pin.

When the bomb strikes its target, the firing pin is forced into the signal primer. The smoke produced from the detonated signal is discharged out the side of the bomb through the blast tube.

Double suspension lugs are spaced 14 inches apart on the bomb body. The lugs are of the screw-in type used with the low-drag general purpose bomb family. At the center of gravity, a hoisting lug is welded to the bomb body.

Identifying nomenclature is stenciled in white on the side of the bomb body. The overall color of the bomb is black.

This bomb is filled with water or wet sand. Antifreeze is added to the filler during freezing conditions.

Physical Characteristics

Weight of assembled bomb with signal:

Loaded with wet sand_ 783 lbs

Loaded with water_ . . . 458 lbs

Dimensions:

Length or height of 119.5 inches
complete bomb

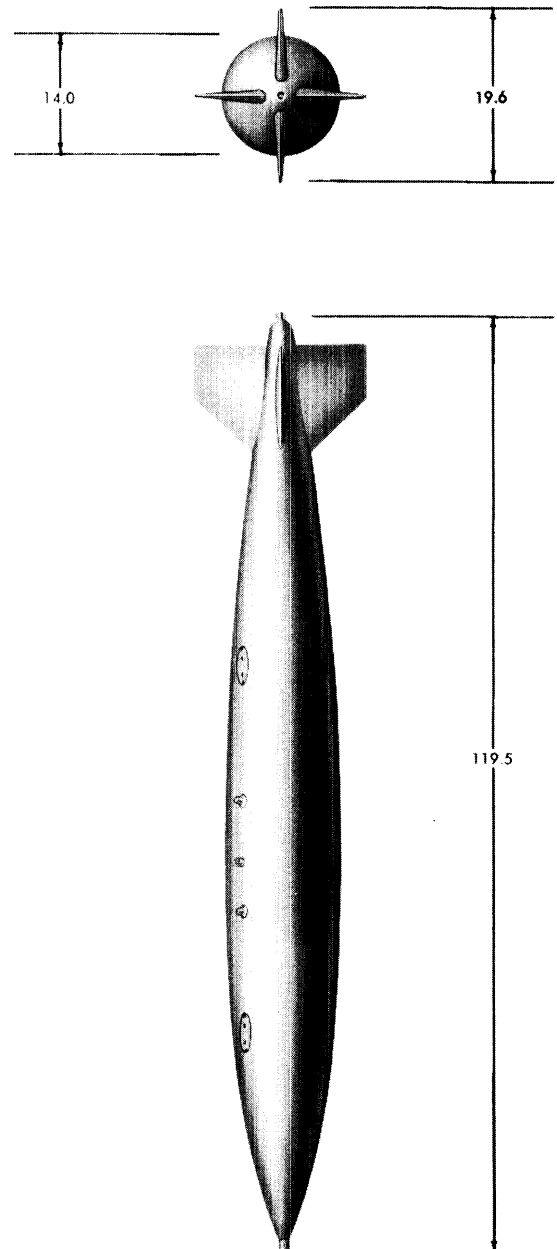

Figure 11.17—1000-lb Practice Bomb Mk 88 Mod 0.

Dimensions—Continued

- Diameter..... 14.0 inches
- Fin span..... 19.6 inches
- Fin length..... 13.3 inches

Suspension:

- Two suspension lugs... 14 inches c to c
- One hoisting lug..... Center of gravity

Components of a Complete Round (Figures 11.18 and 11.19)

Bomb body assembly (including):

- Bomb body
- Filler caps
- Suspension hoisting lugs (2)

Signal:

- AN-Mk 4

Firing pin assembly

Cotter pin

Assembly

CAUTION: Signals and bomb shall not be unpacked in advance of requirements. If unpacked and not used, return them to their original packings.

1. Remove bomb assembly from crate.

CAUTION: Inspect for damage (cracked weldments, etc.) which might cause leaks in the bomb casing or damage to suspension lugs.

2. Remove filler caps from filler holes, using suitable spanner wrench. Inspect gaskets. Damaged gaskets should be replaced.

3. Fill with required amount of water or wet sand at loading base; during freezing conditions, add antifreeze. Filling the bomb with wet sand can be facilitated by filling as much as possible with the bomb in a horizontal position, then reinstalling the forward filler cap, hoisting the tail of the bomb, and filling through the rear filling hole.

4. Twist on filler caps with spanner wrench, until tight and locked.

5. Remove cotter pin and firing pin assembly from the nose of the bomb.

CAUTION: Firing pin assembly must fit loosely and not bind when dropped into position. Inspect firing pin assembly for damage. Be sure firing pin cup is not deformed and that the firing-pin point is below the lip of its cup. Check blast tube. It must be clean and not damaged or blocked in any way.

6. With firing pin assembly removed, elevate nose of bomb. Insert Signal AN-Mk 4, primer end up, and slide it gently into place. Do not force into place. The base flange of the signal cartridge must rest on the blast tube shoulder (about 1 1/8 inches in from the front of the blast tube).

CAUTION: Signals must not be swollen or deformed in any manner. The primer must be flush or slightly below the base of the cartridge. Sig-

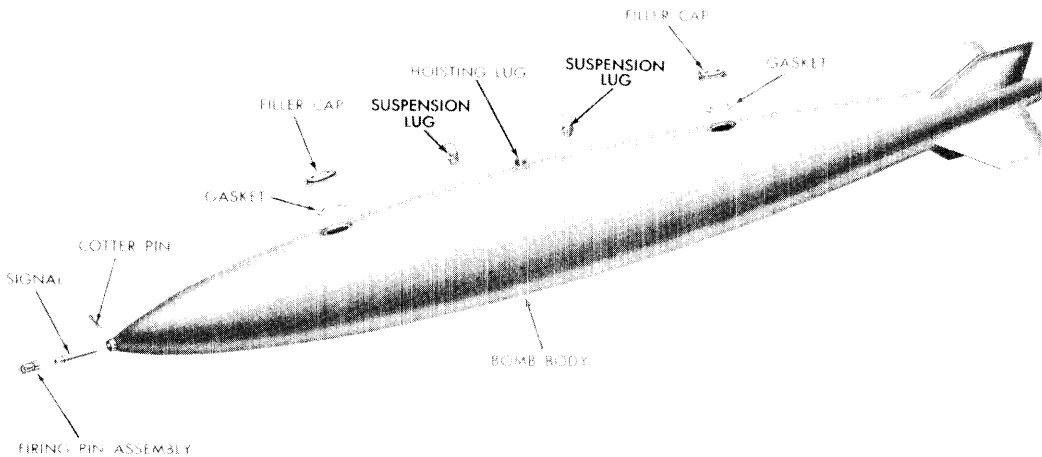

Figure 11.18—1000-lb Practice Bomb Mk 88 Mod 0, Exploded View.

nal cartridges that are deformed in any way shall not be used.

7. Carefully insert firing pin assembly with firing pin end toward the signal.

CAUTION: Firing pin assembly must slide into place without friction. Do not apply pressure to force the firing pin assembly into the bomb because the assembly may collapse and fire the signal.

8. Rotate the firing pin assembly so that the two notches in the lip of the forward cup line up with the pin holes in the blast tube. Do

not apply pressure to the firing pin during this operation.

9. Insert the cotter pin through the pin holes in the blast tube, passing through the notches in the firing pin assembly. Spread the ends of the cotter pin sufficiently to retain it in place.

CAUTION: Do not bend the ends of the cotter pin at right angles to the cotter pin axis, or strike the ends to bend them into position.

10. Install bomb in accordance with type of rack in use and securely lock in place.

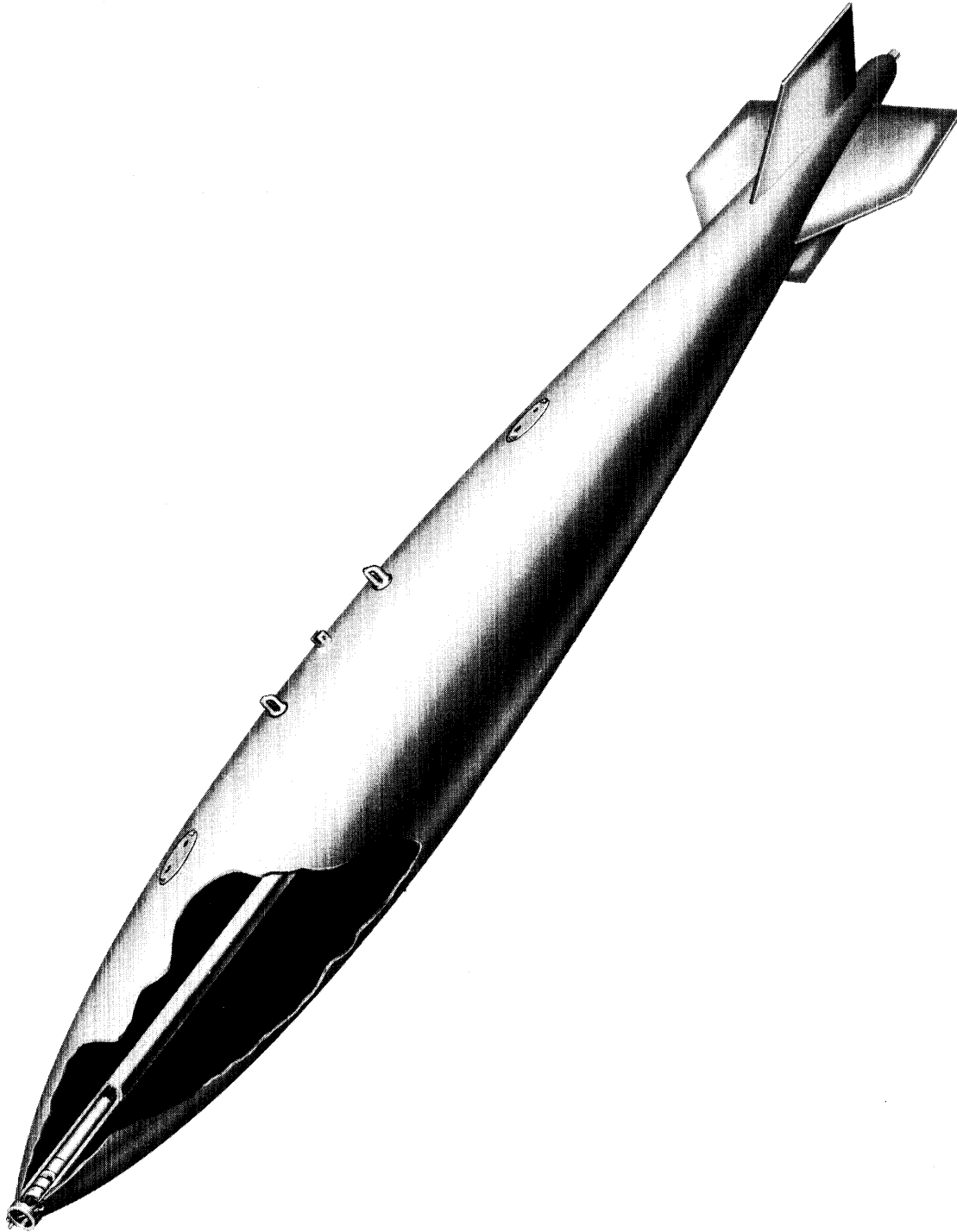

Figure 11.19—1000-lb Practice Bomb Mk 88 Mod 0, Cutaway View.

Section 11.8—2000-lb Practice Bomb Mk 67 Mod 0

Description

The 2000-lb Practice Bomb Mk 67 Mod 0, figure 11.20, has an ogival nose, a cylindrical center section, and a tapered aft end. A box fin assembly is secured to the aft end of the bomb with hex-head bolts. Nose and tail plugs are provided for use in filling the bomb. A filler hole is located on the side of the bomb, and is capped with a circular plate (and gasket) which is secured with hex-head bolts. For added strength and rigidity, reinforcement strips are welded to the inside of the bomb casing.

Practice Bomb Signal Mk 6 Mod 0 seats in the aft end of the bomb in a recess formed by the tail plug. A bracket, supplied with Signal Mk 6 Mod 0, secures the signal to the fin assembly. The bomb is filled with 1473.05 pounds of wet sand or 816.55 pounds of water.

Identifying nomenclature is stenciled in white on the black-painted bomb body and its components. On one side of the bomb, two welded suspension lugs provide for a 30-inch suspension. On the opposite side, suspension lugs are welded to provide for 14-inch suspension.

Physical Characteristics

Weight of assembled fuzed bomb:

- Loaded with wet sand . . . 1617.25 lbs
- Loaded with water 960.75 lbs

Weight of filler:

- Wet sand 1473.05 lbs
- Water 816.55 lbs

Weight of fin assembly . . . 40.0 lbs

Dimensions:

- Length or height of complete bomb 90.3 inches
- Length of bomb body 68.5 inches
- Diameter 23.0 inches
- Fin span 31.6 inches
- Fin length 25.0 inches

Suspension:

- Two suspension lugs 14 inches c to c
- Two suspension lugs 30 inches c to c

Components of a Complete Round (Figures 11.21 and 11.22)

- Bomb body assembly (including):
- Bomb body

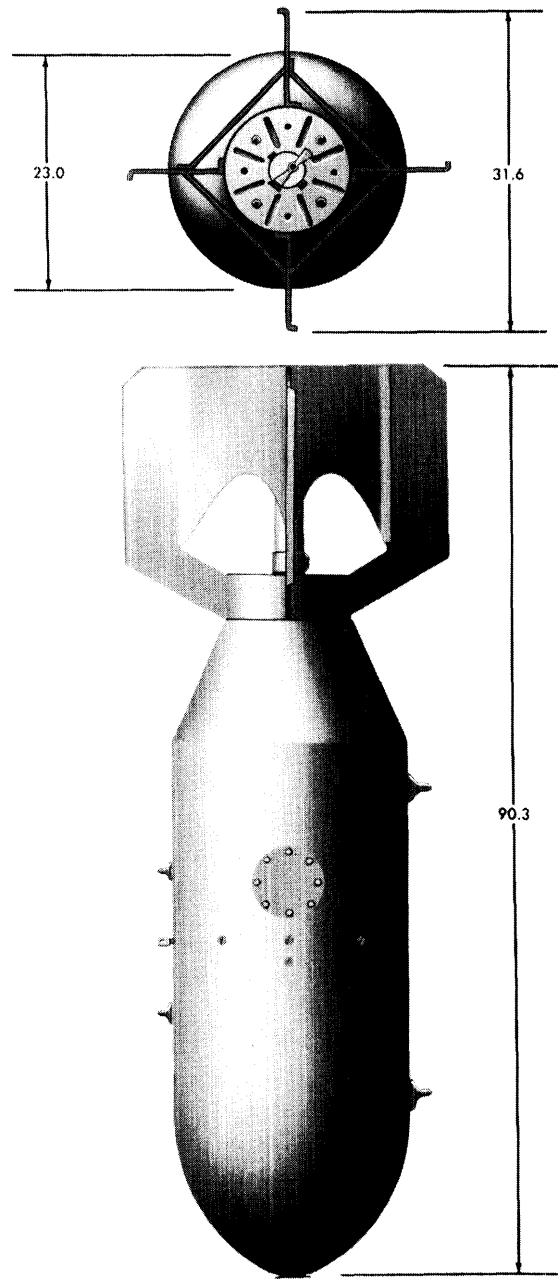

Figure 11.20—2000-lb Practice Bomb Mk 67 Mod 0.

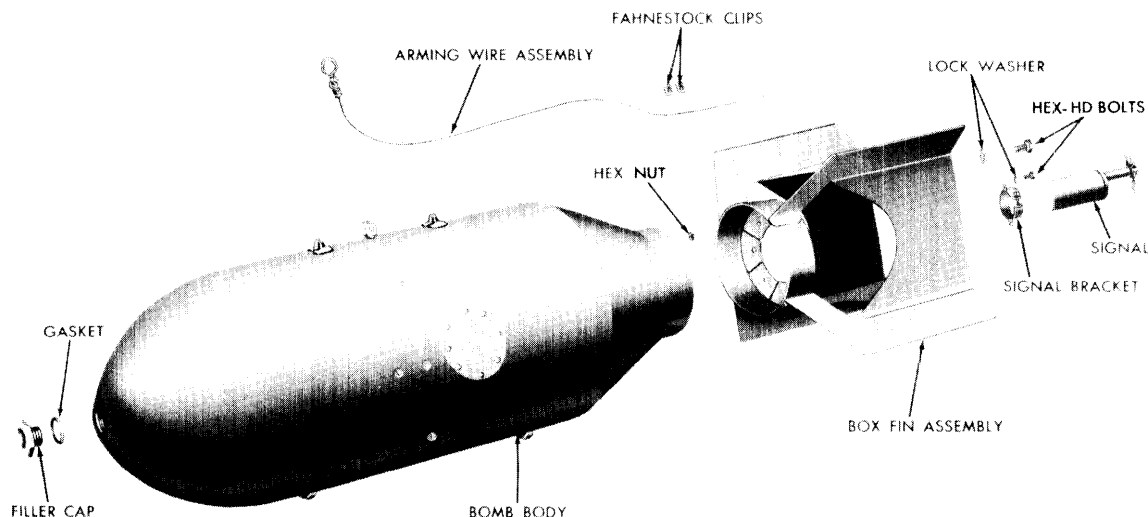

Figure 11.21—2000-lb Practice Bomb Mk 67 Mod 0, Exploded View.

Nose and tail filler plugs, side filler cover with eight bolts and washers
 Box fin assembly with bolts and lock washers
 Signal Mk 6 Mod 0
 Fuze Mk 247 Mod 0
 Arming wire assembly
 Fahnestock clips

Assembly

CAUTION: Signals, fuzes, and bombs shall not be unpacked in advance of requirements. If unpacked and not used, return them to their original packings. Practice bomb signals should be stowed in a dry, ventilated location out of the direct rays of the sun.

1. Remove bomb body from stowage.

CAUTION: Inspect for damage (broken weldments, etc.) which might cause leaks in the bomb casing. Inspect for damaged lugs and lug weldments.

2. Remove nose plug, tail plug, or side filler cover and fill bomb with required amount of wet sand or water; replace the plugs or cover. During freezing conditions, add antifreeze to filler.

3. Remove fin assembly and attachments from shipping crate.

4. Open box containing Practice Bomb

Signal Mk 6 Mod 0. Remove signal bracket from signal.

5. Fasten signal bracket to fin sleeve by squeezing band ends together permitting the slots to be slipped under the rivets on the fin sleeve. The signal bracket is bolted to the fin assembly with the nut, bolt, and lock washer provided.

6. Depending upon type of suspension used, the holes in the fin assembly base and bomb base plug should be aligned so that the fins will clear the aircraft structure and ground, when the bomb is installed. Place lock washers over bolts; insert bolts through holes of fin sleeve and thread into bomb body base securing fin assembly.

CAUTION: Do not use fin assembly if it cannot be secured to the bomb properly.

7. Install the cylindrical section of Practice Bomb Signal Mk 6 Mod 0. For detailed information of fuzing and defuzing using Practice Bomb Signal Mk 6 Mod 0 and Fuze Mk 247, refer to OP 988 (First Revision).

8. After installation of signal and fuze, install bomb in accordance with type of rack in use.

CAUTION: Do not remove safety cotter pin until bomb is in place in the aircraft and the arming wire is installed completely.

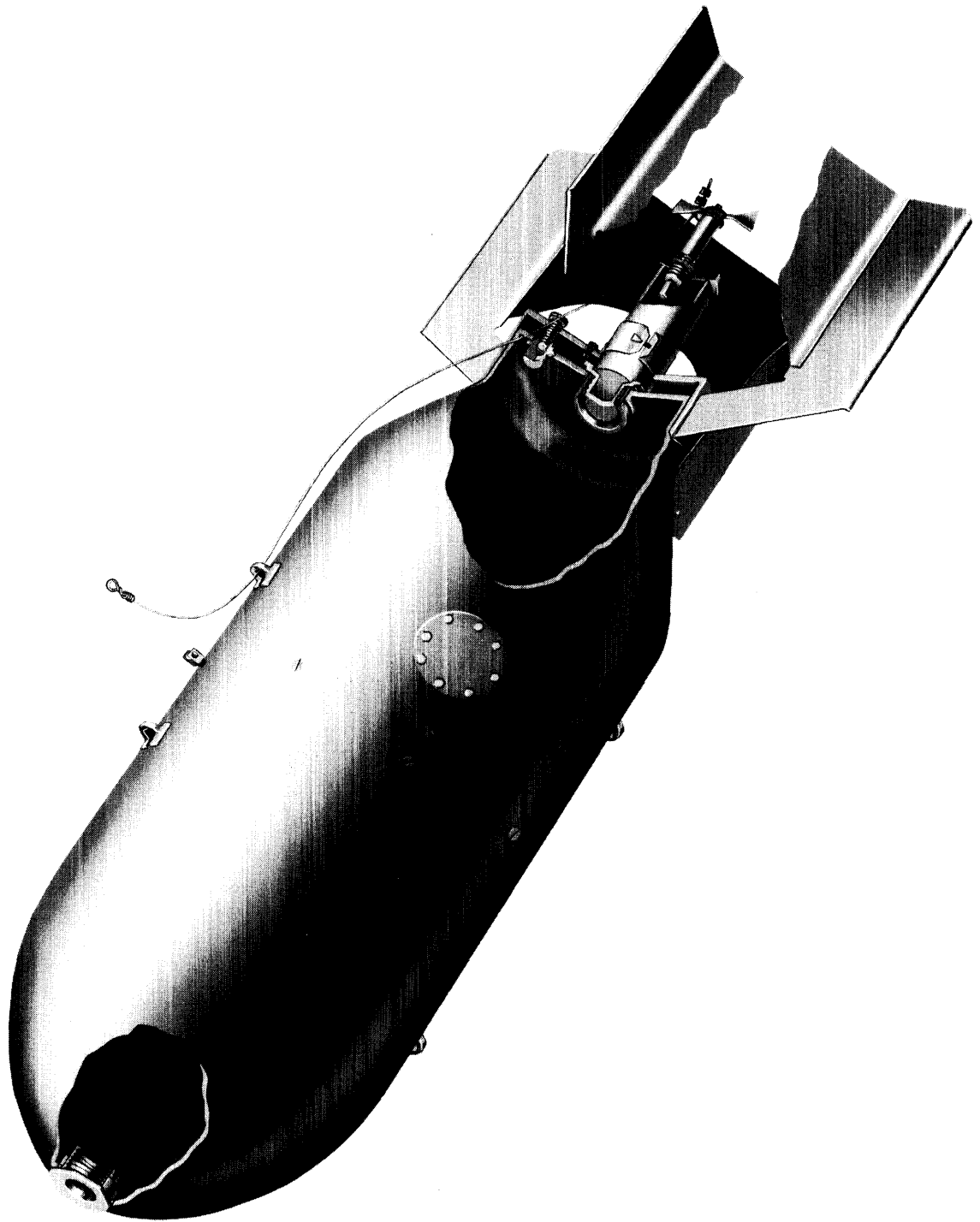

Figure 11.22—2000-lb Practice Bomb Mk 67 Mod 0, Cutaway View.

Section 11.9—250 lb. Practice Bomb Mk 86 Mod 0

Description

The 250-lb Practice Bomb Mk 86 Mod 0, figure 11.23, is a low-drag bomb of the same size and shape as the Mk 81 series of low-drag general purpose bombs. It has a streamlined nose and a conically tapered aft end. One filler hole is located on the side, aft of the cylindrical section. Four fin blades perpendicular to each other are located forward of the rear end of the bomb.

The 250-lb Practice Bomb Mk Mod 0 is of thin-case construction with internal reinforcement for the sway brace and ejection areas. To provide rigidity, bulkheads and channel reinforcements are used on the inside of the bomb shell.

The Practice Bomb Signal AN-Mk 4 is used with the 250-lb Practice Bomb Mk 86 Mod 0. A blast tube extends from the nose to the aft end of the bomb and allows for exit of the signal smoke when fired. The firing pin assembly and signal are held in place inside the blast tube by a retaining cotter pin.

When the bomb strikes its target, the firing pin is forced into the signal primer. The smoke produced from the detonated signal is discharged out the end of the bomb through the blast tube.

Double suspension lugs are spaced 14 inches apart on the bomb body. The lugs are of the screw-in type used with the low-drag general purpose bomb family. A screw-in type of hoisting lug is provided at the center of gravity of the bomb.

Identifying nomenclature is stenciled in white on the side of the bomb body. The overall color of the bomb is black.

This bomb is filled with water or wet sand. Antifreeze is added to the filler during freezing conditions.

Physical Characteristics

- Weight of assembled bomb with signal:
- Loaded with wet sand . . . 217 lbs
- Loaded with water 141 lbs

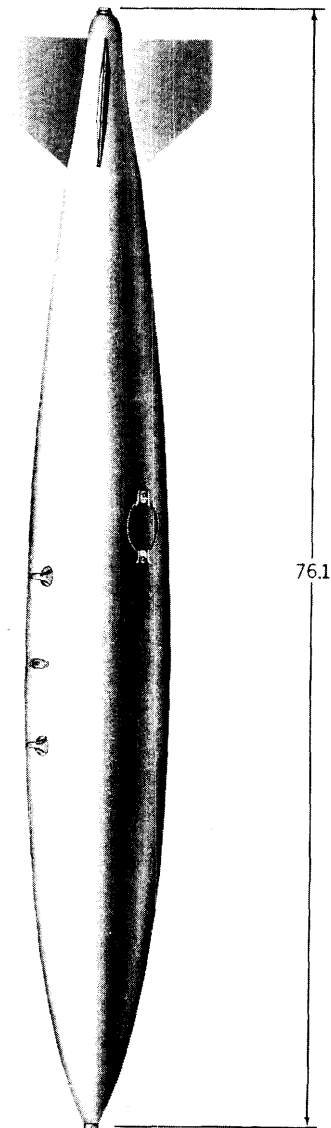
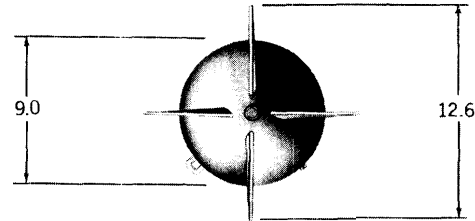

Figure 11.23—250-lb Practice Bomb Mk 86 Mod 0.

Dimensions

Length or height of complete bomb	76.1 inches
Diameter	9.0 inches
Fin Span	12.6 inches
Fin Length	8.4 inches

Suspension

Two suspension lugs . .	14 inches c to c
One hoisting lug . . .	Center of gravity

Components of a Complete Round (Figures 11.24 and 11.25)

Bomb Body Assembly (including):

- Bomb Body
- Filler Cap
- Filler cap clamps, screws, and lockwasher (2 each)
- Suspension lugs (2)
- Hoisting lug

Signal:

- AN-Mk 4 Practice Bomb Signal
- Mk 1 Mod 0 Firing Pin Assembly
- Cotter Pin

not used, return them to their original packings.

1. Remove bomb assembly from crate. CAUTION: Inspect for damage (cracked weldments, etc.) which might cause leaks in the bomb casing or damage to suspension lugs.
2. Remove safety wire from suspension lugs and hoisting lug.
3. Remove the filler cap from the filler hole by backing off the screws holding the two clamps in place until the clamps can be turned aside. Do not completely remove these screws in order to prevent possible loss of the screws or lockwashers. Inspect the gasket. Damaged gaskets should be replaced.
4. Fill with required amount of water or wet sand at loading base; during freezing conditions add antifreeze. Filling the bomb with wet sand can be facilitated by hoisting the tail so the filler will flow toward the nose.
5. Replace filler cap making sure the gasket and gasket seat are free of loose grains of sand. Turn the filler cap clamps into locking position and tighten the screws securely.

Assembly

CAUTION: Signals and bomb shall not be unpacked in advance of requirements. If unpacked and

CAUTION: Check to make sure the lockwashers are in place under the heads of the screws.

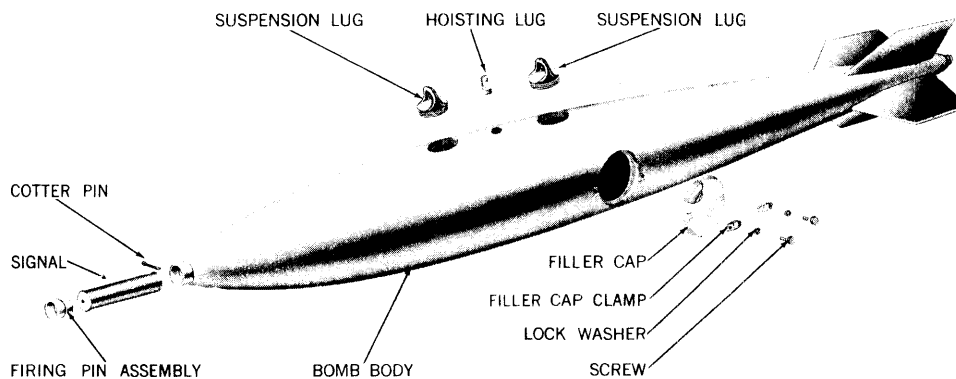

Figure 11.24—250-lb Practice Bomb Mk 86 Mod 0, Exploded View.

6. Remove cotter pin and firing pin assembly from the nose of the bomb.

CAUTION: Firing pin assembly must fit loosely and not bind when dropped into position. Inspect firing pin assembly for damage. Be sure firing pin cup is not deformed and that the firing pin point is below the lip of its cup. Check the blast tube. It must be clean and not damaged or blocked in any way.

7. With firing pin assembly removed, elevate nose of bomb. Insert Signal AN-Mk 4, primer end up, and slide it gently into place. Do not force into place. The base flange of the signal cartridge must rest on the blast tube shoulder (about 1½ inches in from the front of the blast tube).

CAUTION: Signals must not be swollen or deformed in any manner. The primer must be flush or slightly below the base of the cartridge. Signal cartridges that are deformed in any way shall not be used.

8. Carefully insert firing pin assembly with firing pin end toward the signal.

CAUTION: Firing pin assembly must slide into place without friction. Do not apply pressure to force the firing pin assembly into the bomb because the assembly may collapse and fire the signal.

9. Rotate the firing pin assembly so that the two notches in the lip of the forward cup line up with the pin holes in the blast tube. Do not apply pressure to the firing pin during this operation.

10. Insert the cotter pin through the pin holes in the blast tube, passing through the notches in the firing pin assembly. Spread the ends of the cotter pin just enough to retain it in place.

CAUTION: Do not bend the ends of the cotter pin at right angles to the cotter pin axis, or strike the ends to bend them into position.

11. Install bomb in accordance with type of rack in use and securely lock in place.

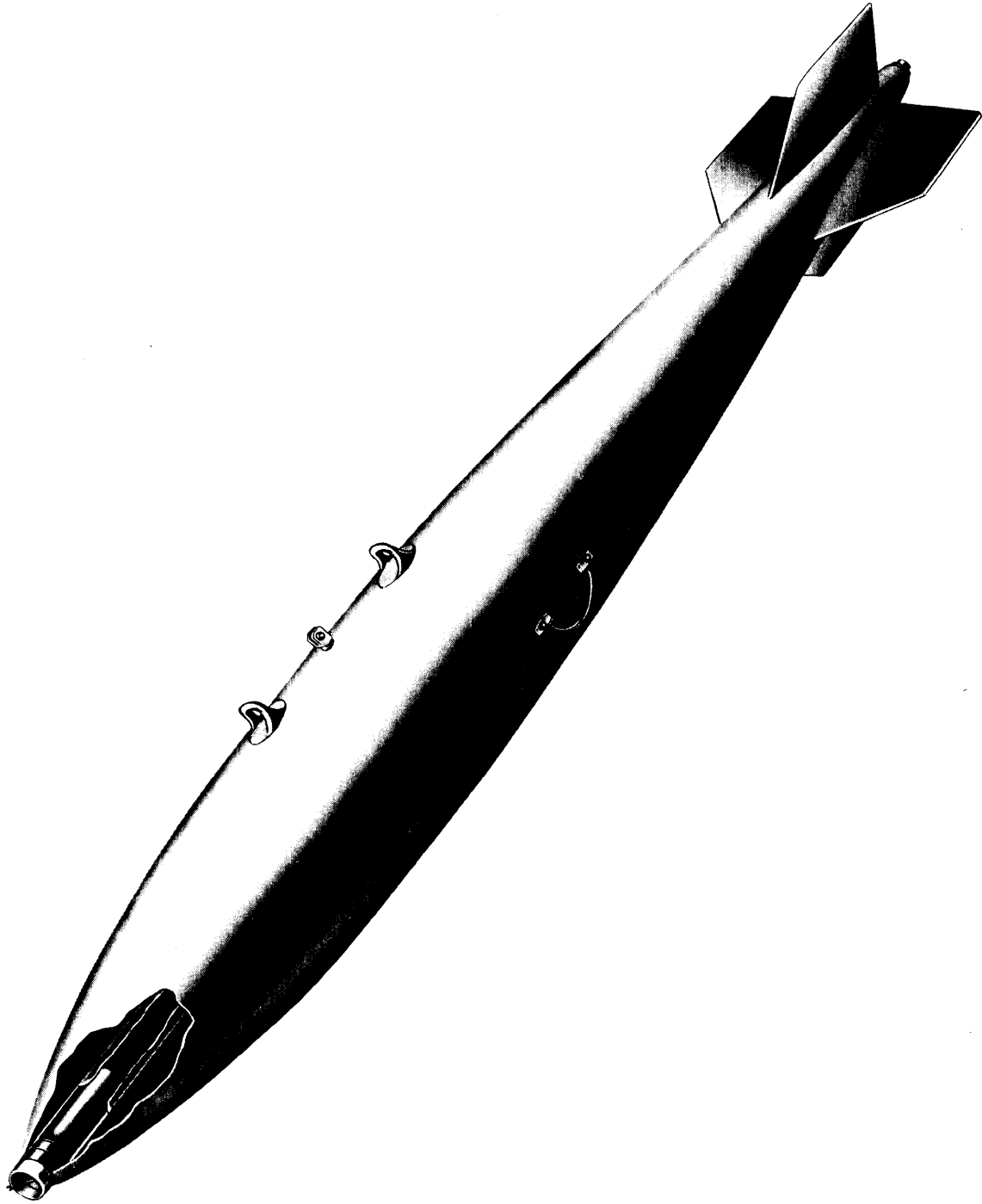

Figure 11.25—250-lb Practice Bomb Mk 86 Mod 0, Cutaway View.

Section 11.10—56 lb. Practice Bomb Mk 89 Mod 0

Description

The 56 lb. Practice Bomb Mk 89 Mod 0, figure 11.26, is a low-drag practice bomb, similar in shape to the low drag series of general purpose bombs. The cast iron body is slender, with a long pointed nose. The conical type fin assembly is of welded sheet metal construction. The tail fins are canted 2 degrees to impart spin to the bomb.

Firing Pin Mk 1 Mod 0 and Practice Bomb Signal Mk 4 Mod 3 are installed in the forward end of the bomb and are secured by a retaining cotter pin. The smoke produced by the detonated signal is discharged out the rear of the tail fin. The signal will function on land or water impacts.

Two suspension lugs are spaced 14 inches apart on the bomb body. These lugs are threaded and may be removed and replaced by shipping plugs when it is desired to use the bomb in dispensers. Two 3/8 inch holes are drilled into the body at the center of gravity; these holes accommodate the Aero 8A Dispenser.

Identifying nomenclature is stenciled in white marking ink on the side of the body. The exterior surface of the bomb is coated with black enamel. A 1/4 inch white stripe is painted around the body at the center of gravity.

Physical Characteristics

Weight of assembled bomb	
with signal	56.5 lbs
Weight of body	53.8 lbs
Weight of fin assembly	2.4 lbs
Weight of firing pin, signal,	
and plugs	0.3 lb

Dimensions:

Length or height of complete	
bomb	31.3 inches
Length of bomb body	20.6 inches
Body diameter,	
maximum	4.0 inches

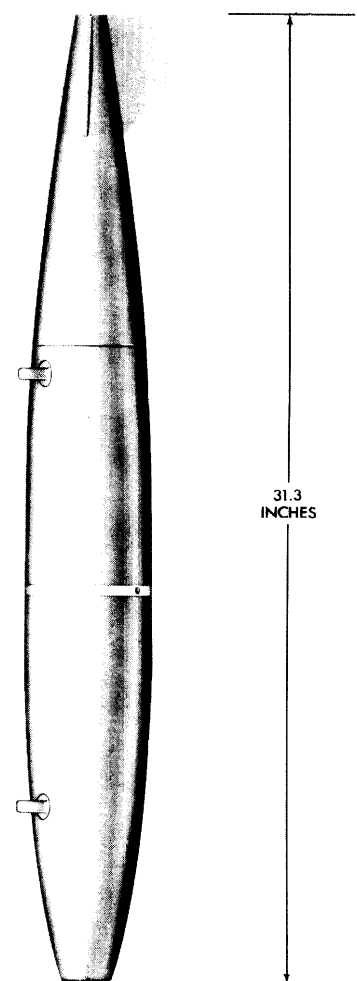
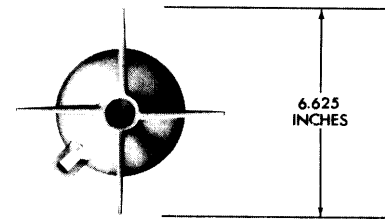

Figure 11.26—56 lb Practice Bomb Mk 89 Mod 0.

- Fin span 6.6 inches
- Length of
fin assembly 10.7 inches
- Suspension:
Two suspension lugs . . . 14 inches c to c

**Components of a Complete Round
(Figures 11.27 and 11.28)**

- Bomb body (with fin assembly)
- Suspension lugs (2)
- Cotter pin
- Firing Pin Mk 1 Mod 0
- Practice Bomb Signal Mk 4 Mod 3

Assembly

CAUTION: Signals and bombs shall not be unpacked in advance of requirements. If unpacked and not used, return them to their original packings.

1. Remove the bomb assembly and the signal assembly from their packings. Practice Bomb Mk 89 Mod 0 is shipped from the manufacturer with the firing pin assembly installed and with a retaining cotter pin through the nose end.

2. Remove cotter pin and firing pin assembly from nose of bomb.

CAUTION: Firing pin assemblies must fit loosely and not bind when dropped into position. Inspect firing pin assembly for damage. Be sure firing pin cup is not deformed and that the firing pin point is below the lip of its cup. Check bore through center of bomb; bore must be clear.

3. With the firing pin assembly removed, elevate nose of bomb. Insert Practice Bomb Signal Mk 4 Mod 3, primer end up, and slide it gently into place. Do not use force. The base flange of the signal cartridge must rest on the bore shoulder (about 1-1/4 inches in from the nose of the bomb).

CAUTION: Signals must not be swollen or deformed in any manner. The primer must be flush or slightly below the base of the cartridge. Signal cartridges that are deformed in any way shall not be used.

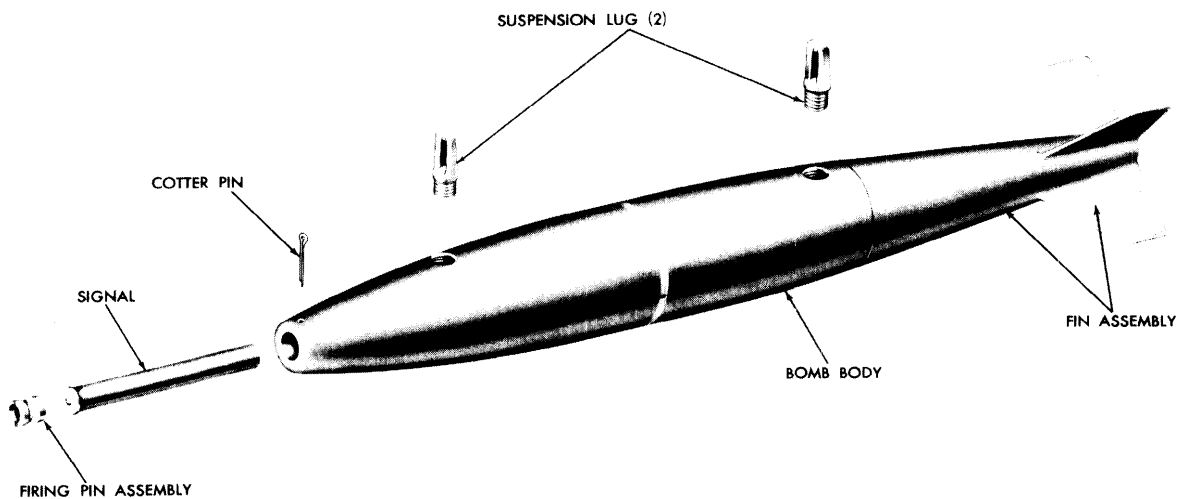

Figure 11.27—56 lb Practice Bomb Mk 89 Mod 0, Exploded View.

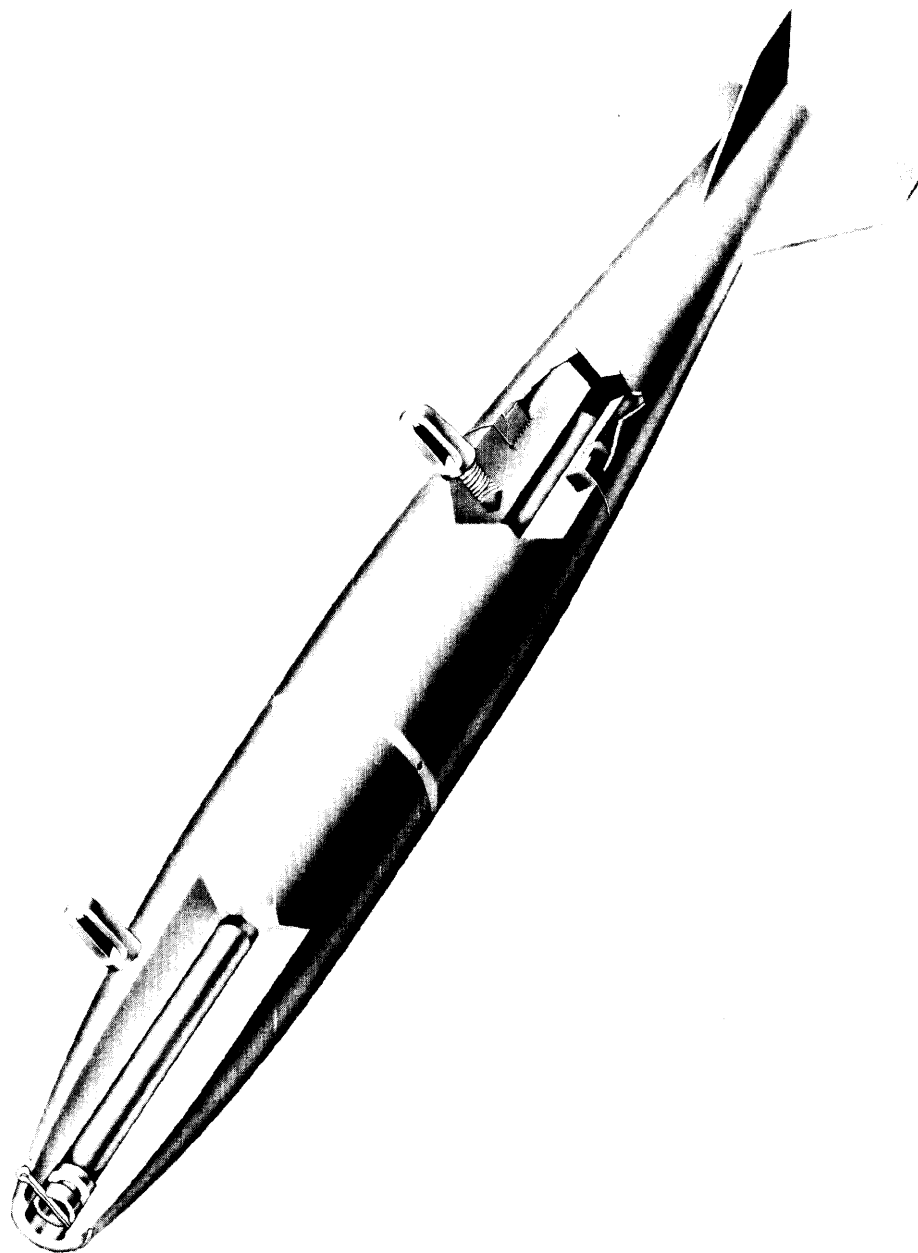

Figure 11.28—56 lb Practice Bomb Mk 89 Mod 0, Cutaway View.

4. Carefully insert firing pin assembly with firing pin end toward the signal.

CAUTION: Firing pin assembly must slide into place under its own weight. Do not apply pressure to force the firing pin assembly into the bomb because the assembly may deform and fire the signal.

5. Rotate the firing pin assembly so that the two U-shaped notches in the lip of the forward cup line up with the pin

holes in the bomb nose. Do not apply pressure to the firing pin during this operation.

6. Insert the cotter pin through the pin holes in the nose, passing through the notches in the firing pin assembly. Spread the ends of the cotter pin just enough to retain it in place.

CAUTION: Do not bend the ends of the cotter pin at right angles to the cotter pin axis, or strike the ends to bend them in position.

Section 11.11—500 lb. Practice Bomb Mk 87 Mod 0

Description

The 500 lb. Practice Bomb Mk 87 Mod 0, figure 11.29, is a low-drag practice bomb, similar in size and shape to the Mk 82 series of general purpose bombs. It has a long pointed nose and a conically tapered aft end. One filler hole is located on the side, aft of the rear suspension lug. The four tail fins are canted 1-½ degrees to impart spin to the bomb.

The 500 lb. Practice Bomb Mk 87 Mod 0 is of thin-case construction with internal reinforcement for the sway brace and ejection areas. To provide rigidity, bulkheads and channel reinforcements are used on the inside of the bomb casing.

Firing Pin Mk 1 Mod 0 and Practice Bomb Signal Mk 4 Mod 3 are installed in the forward end of the bomb, and are secured by a cotter pin. The detonated signal produces smoke which is discharged out the rear of the blast tube.

Two suspension lugs are spaced 14 inches apart on the body. A hoisting lug is located midway between the suspension lugs.

Identifying nomenclature is stenciled in white on the side of the bomb body. The overall color of the bomb is black.

The bomb is filled with 235 pounds of wet sand or 123 pounds of water.

Physical Characteristics

Weight of assembled bomb with signal:
 Empty assembled bomb 98 lbs
 Loaded with wet sand 333 lbs
 Loaded with water 221 lbs

Dimensions:
 Length or height of complete bomb 90.89 inches
 Maximum body diameter 10.75 inches
 Fin span 15.06 inches

Suspension:
 Two suspension lugs 14 inches c to c
 One hoisting lug Center of gravity

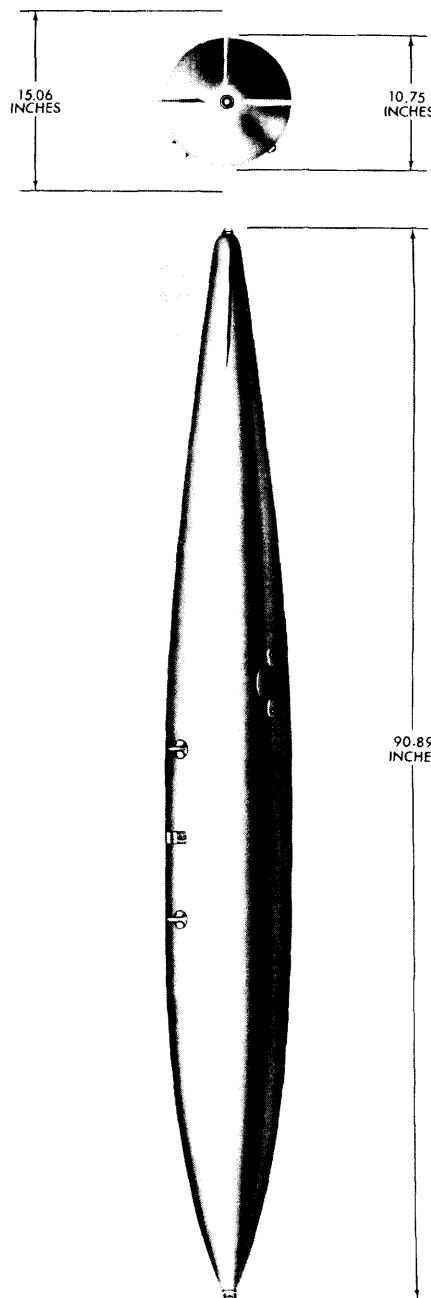

Figure 11.29—500 lb Practice Bomb Mk 87 Mod 0.

Components of a Complete Bomb (Figures 11.30 and 11.31)

Bomb body (with fin assembly)
Suspension lugs (2)
Hoisting lug
Hoisting lug
Cotter pin
Firing Pin Mk 1 Mod 0
Practice Bomb Signal Mk 4 Mod 3

Assembly

CAUTION: Signals and bomb shall not be unpacked in advance of requirements. If unpacked and not used, return them to their original packings.

1. Remove the bomb assembly from the packing.

CAUTION: Inspect for damage (cracked weldments, etc.) which might cause leaks in the bomb casing or damage to suspension lugs.

2. Remove filler cap by backing off the screws holding the two clamps in place

until the clamps can be turned aside. Inspect the cap gasket and clamps for proper fit. Replace damaged gaskets.

3. Fill with the required amount of wet sand or water at the loading base. During freezing conditions add antifreeze. Filling the bomb with wet sand can be facilitated by hoisting the tail so the filler will flow toward the nose.

4. Replace filler cap after clearing channel and gasket seal of loose grains of sand. Turn the filler cap clamps into locking position and tighten the screws securely.

5. Remove cotter pin and firing pin assembly from the nose of the bomb.

CAUTION: Firing pin assembly must fit loosely and not bind when dropped into position. Inspect firing pin assembly for damage. Be sure firing pin cup is not deformed and that the firing pin point is below the lip of its cup. Inspect the blast tube. It must be clean and not damaged or blocked in any way.

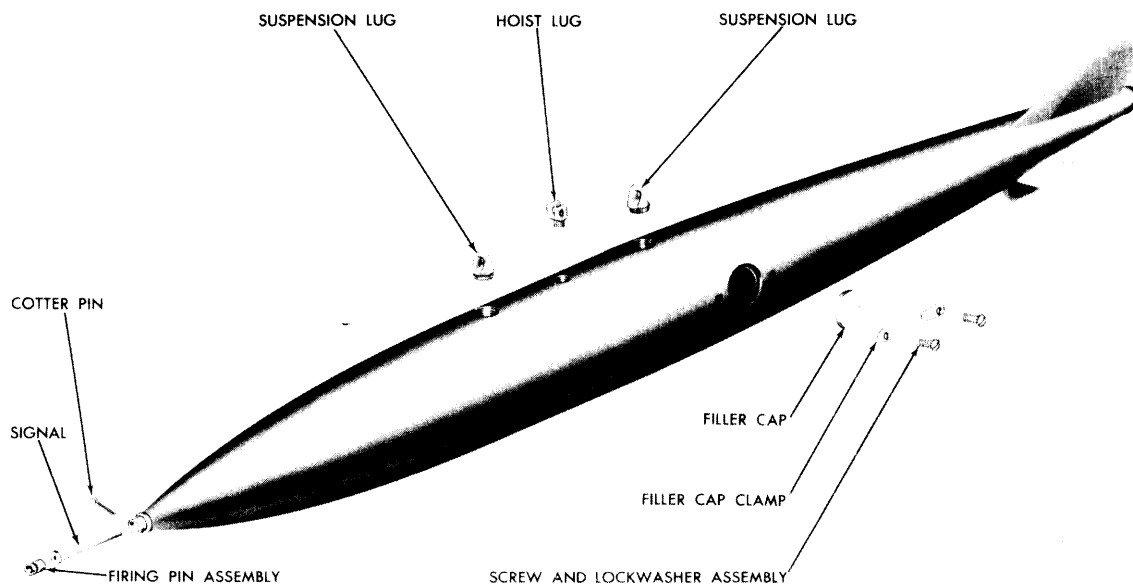

Figure 11.30—500 lb Practice Bomb Mk 87 Mod 0, Exploded View.

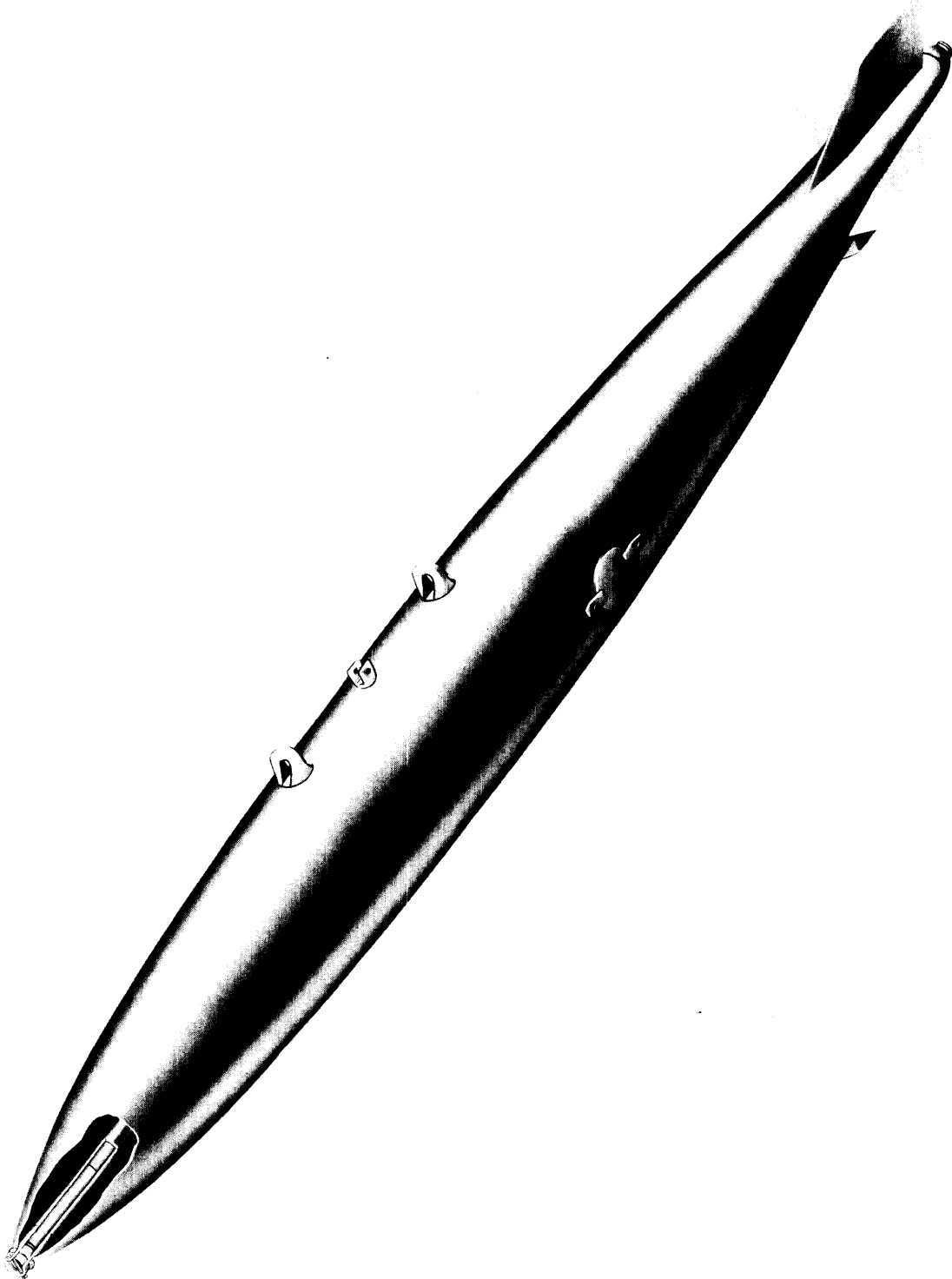

Figure 11.31—500 lb Practice Bomb Mk 87 Mod 0, Cutaway View..

6. With firing pin assembly removed, elevate nose of bomb. Insert signal, primer end up, and slide it gently into place. Do not force into place. The base flange of the signal cartridge must rest on the blast tube shoulder (about 1- $\frac{1}{8}$ inches in from the nose of the blast tube).

CAUTION: Signal must not be swollen or deformed in any manner. The primer must be flush or slightly below the base of the cartridge. Signal cartridges that are deformed in any way shall not be used.

7. Carefully insert firing pin assembly with firing pin end toward the signal.

CAUTION: Firing pin assembly must slide into place under its own weight. Do not apply pressure to force the firing pin assembly into the bomb because the as-

sembly may deform and fire the signal.

8. Rotate the firing pin assembly so that the two U-shape notches in the lip of the forward cup line up with the pin holes in the nose of the blast tube. Do not apply pressure to the firing pin during this operation.

9. Insert the cotter pin through the pin holes in the bore, passing through the notches in the firing pin assembly. Spread the ends of the cotter pin just enough to retain it in place.

CAUTION: Do not bend the ends of the cotter pin at right angles to the cotter pin axis, or strike the ends to bend them into position.

10. Install bomb in accordance with type of bomb rack in use and securely lock in place.

Section 11.12—25 lb. Practice Bomb Mk 76 Mod 1

Description

The 25 lb. Practice Bomb Mk 76 Mod 1, figure 11.32, is designed for air burst firing. It has an elongated, teardrop-shaped bomb body. The fin assembly is composed of four fin blades and a shroud welded to a center tube. A conical section covers the center tube and is threaded to the body section. The two sections are staked together to prevent unscrewing. A setscrew is threaded into the nose of the bomb to retain the time fuze and signal.

The time fuze fires the signal which is seated in the bore of the body section. Smoke produced from the detonated signal is discharged rearward through the tube of the fin assembly.

CAUTION: Tests have shown that the fuze will fragment the bomb body producing a maximum fragment weight of 254 grams and a maximum fragment velocity of 98 feet per second. Proper precautions should be taken to ensure that any personnel who may be scoring drops of this bomb are beyond the maximum range of the burst.

A single suspension lug is threaded into the bomb body and cemented in place. Two 3/8-inch indexing holes are drilled into the body at the center of gravity to accommodate the Aero 8A Dispenser.

Identifying nomenclature is stenciled in white marking ink on the side of the body. The exterior surface of the bomb is coated with black enamel. A 1/4-inch white stripe is painted around the body at the center of gravity.

Physical Characteristics

Weight of assembled bomb with Signal Mk 4 Mod 3 and AN-M146E3 Time Fuze . . .	25.10 lbs
Weight of Signal Mk 4 Mod 3	0.1 lb

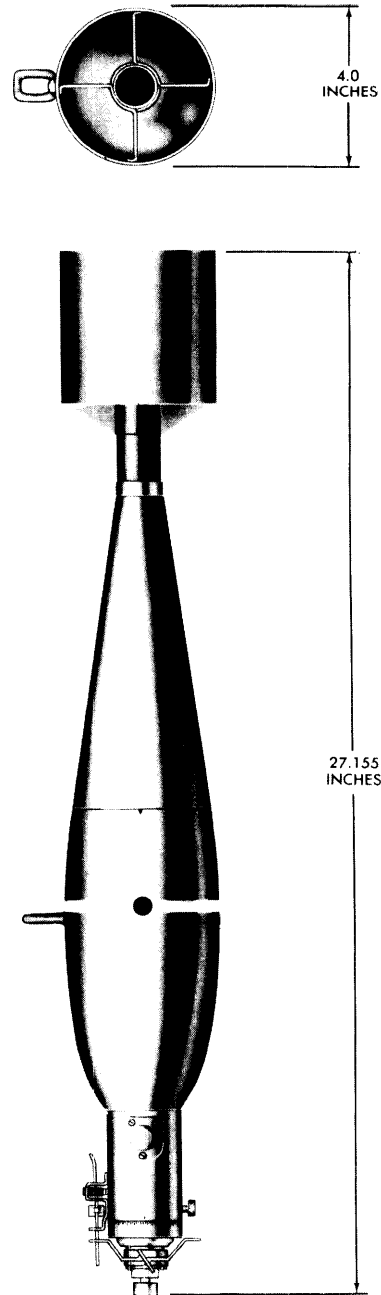

Figure 11.32—25 lb Practice Bomb Mk 76 Mod 1.

Weight of AN-M146E3
 Time Fuze 1.60 lbs

Dimensions:

Length or height of
 complete bomb 27.155 inches

Length of
 bomb body 7.78 inches

Diameter 4.00 inches

Fin span 4.00 inches

Length of fin
 assembly 14.50 inches

Suspension:
 Single suspension
 lug center of gravity

Assembly

CAUTION: Signals, fuzes, and bombs shall not be unpacked in advance of requirements. If unpacked and not used, return them to their original packings.

Assembly Using AN-M146E3 Time Fuze.

1. Remove bomb assembly from crate.
2. Verify that setscrew is backed off sufficiently to permit entrance of fuze.
3. Place bomb in a vertical position with the nose end up.
4. Remove signal from packing and insert signal into bomb, primer end up, and let it gently slide into place. Do not use force. The base flange of the signal cartridge must rest on the bomb bore shoulder (about 1.0 inch from the nose of the bomb).

CAUTION: Signals must not be swollen or deformed in any manner. The primer must be flush or slightly below the base of the cartridge. Signal cartridges that are deformed in any way shall not be used.

Components of a Complete Round (Figures 11.33 and 11.34)

- Bomb body (with fin assembly)
- Suspension Lug 448376
- AN-565-D-1032 H5 Setscrew
- AN-M146E3 Time Fuze
- Arming wire
- Fahnestock clip
- Practice Bomb Signal Mk 4 Mod 3

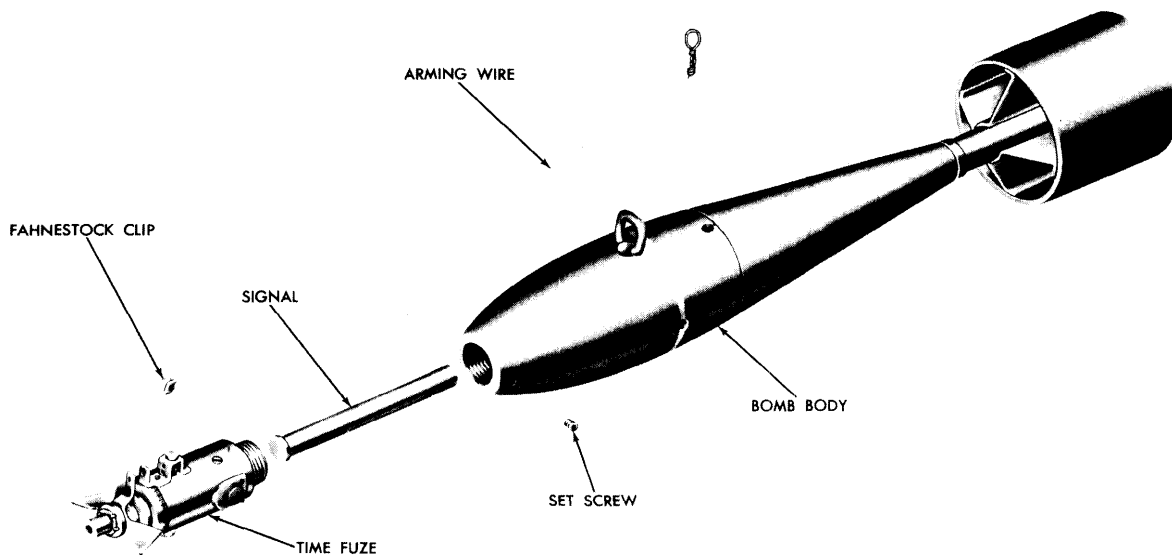

Figure 11.33—25 lb Practice Bomb Mk 76 Mod 1, Exploded View.

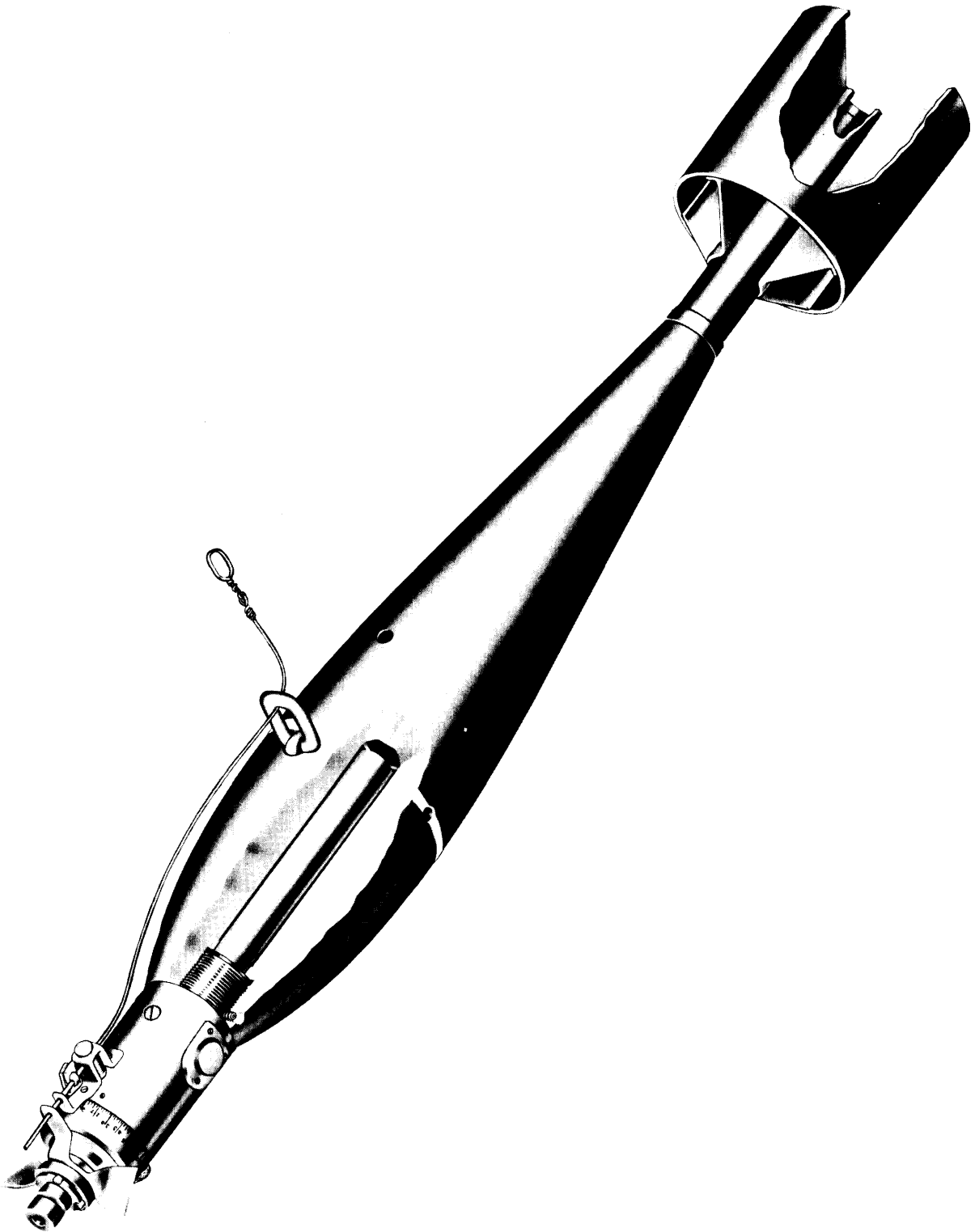

Figure 11.34—25 lb Practice Bomb Mk 76 Mod 1, Cutaway View.

5. Remove fuze from packing and inspect fuze to ensure that the fuze safety devices are in place. For detailed information on fuzing and defuzing, refer to OP 988 (First Revision).

CAUTION: If a fuze is armed or otherwise unsafe to handle, the fuze shall be disposed of by authorized personnel.

6. Carefully screw fuze into nose of bomb until seated, then back off a portion of one turn until arming pin is in line with suspension lug.

7. Tighten setscrew to lock fuze in place.

8. Install arming wire and Fahnestock clip.

Section 11.13—25 lb. Practice Bomb Mk 76 Mod 2

Description

The 25 lb. Practice Bomb Mk 76 Mod 2, figure 11.35, has an elongated, teardrop-shaped bomb body. The fin assembly is composed of four fin blades and a shroud welded to a center tube. A conical section covers the center tube and is threaded to the body section. The two sections are staked together to prevent unscrewing. A cotter pin is inserted through the nose of the bomb to retain the firing pin assembly and signal.

The firing pin assembly fires the signal which is seated in the bore of the body section. Smoke produced from the detonated signal is discharged rearward through the tube of the fin assembly.

A single suspension lug is threaded into the bomb body and cemented in place. Two 3/8-inch indexing holes are drilled into the body at the center of gravity to accommodate the Aero 8A Dispenser.

Identifying nomenclature is stenciled in white marking ink on the side of the bomb. The exterior surface of the bomb is coated with black enamel. A 1/4-inch white stripe is painted around the body at the center of gravity.

Physical Characteristics

Weight of assembled bomb with signal and firing pin . . .	23.70 lbs
Weight of Signal Mk 4 Mod 3	0.16 lb
Weight of Firing Pin Mk 1 Mod 0	0.04 lb
Dimensions:	
Length or height of complete bomb	22.5 inches
Length of bomb body	8.0 inches
Diameter	4.0 inches
Length of fin assembly	14.5 inches
Suspension:	
Single suspension lug	center of gravity

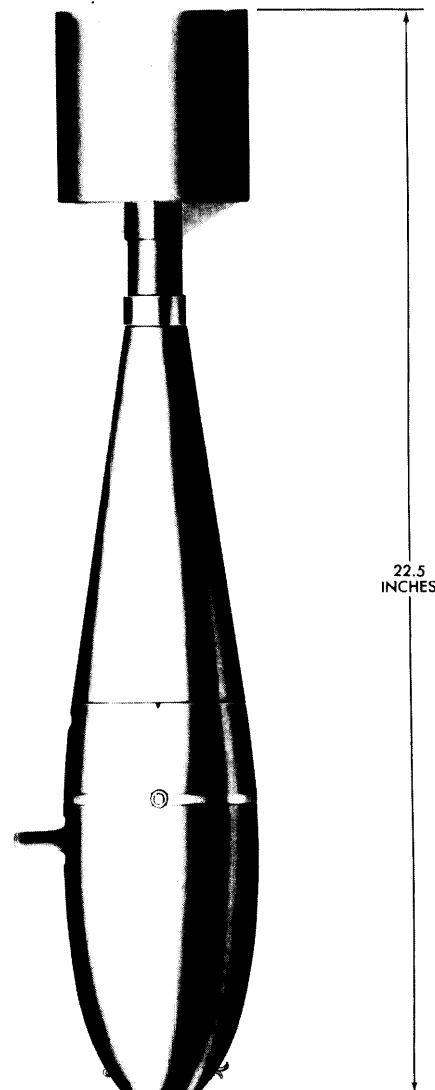
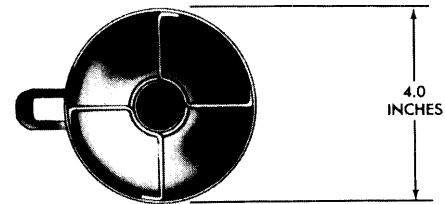

Figure 11.35—25 lb Practice Bomb Mk 76 Mod 2.

Components of a Complete Round (Figures 11.36 and 11.37)

Bomb body assembly (including):
 Bomb body (with fin assembly)
 Cotter pin
 Firing Pin Mk 1 Mod 0

Signal:
 Practice Bomb Signal Mk 4 Mod 3

Assembly

CAUTION: Signals and bombs shall not be unpacked in advance of requirements. If unpacked and not used, return them to the original packings.

Assembly Using Signal Mk 4 Mod 3.

1. Remove required number of bombs and signals from the packings. Practice Bomb Mk 76 Mod 2 is shipped from the manufacturer with a firing pin assembly installed and with a retaining cotter pin through the nose end.

2. Remove cotter pin and firing pin assembly from nose of the bomb.

CAUTION: Firing pin assemblies must fit loosely and not bind when dropped into position. Inspect firing pin assembly for damage. Be sure firing pin cup is not deformed and that the firing-pin point is below the lip of the cup. Check bore through center of bomb; bore must be smooth and clean, and not damaged in any way.

3. With firing pin assembly removed, place bomb in a vertical position with nose end up.

4. Insert signal into bomb, primer end up, and let it gently slide into place. Do not use force. The base flange of the signal cartridge must rest on the bomb bore shoulder (about 1- $\frac{1}{4}$ inch in from the nose of the bomb).

CAUTION: Signals must not be swollen or deformed in any manner. The primer must be flush or slightly below the base of the

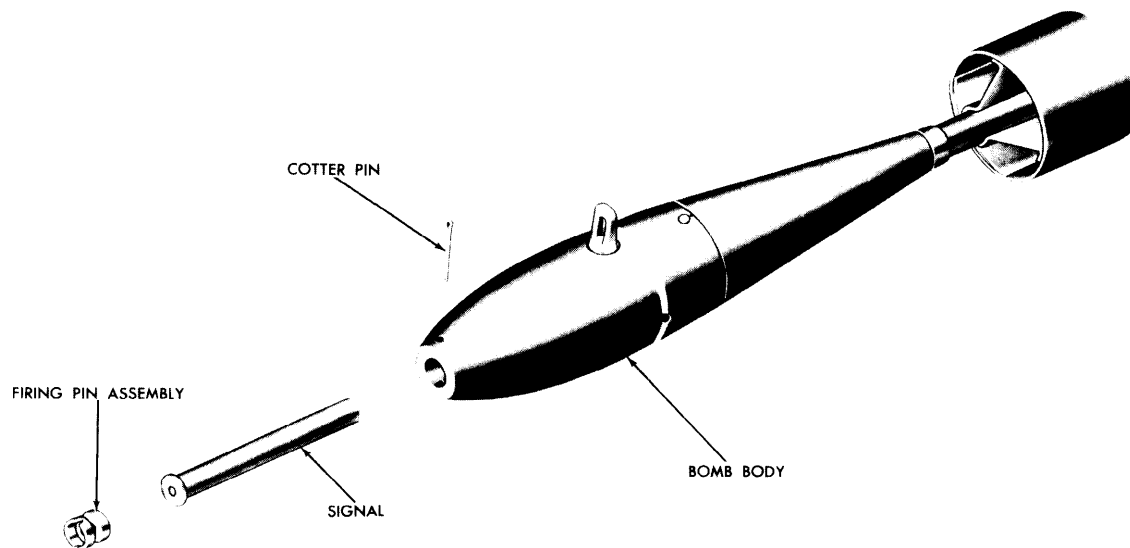

Figure 11.36—25 lb Practice Bomb Mk 76 Mod 2, Exploded View.

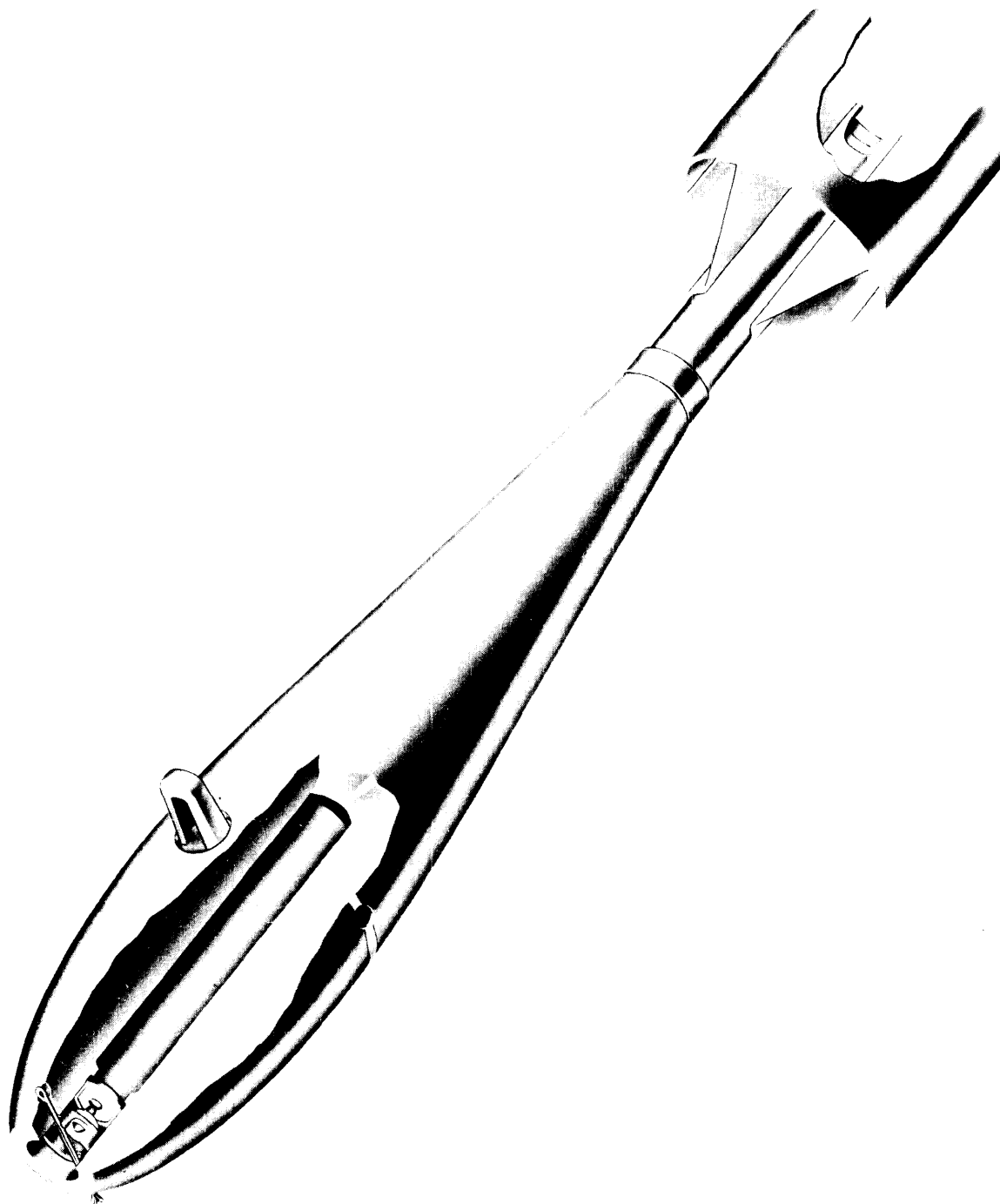

Figure 11.37—25 lb Practice Bomb Mk 76 Mod 2, Cutaway View.

cartridge. Signal cartridges that are deformed in any way shall not be used.

5. Carefully insert firing pin assembly with firing pin end toward signal.

CAUTION: Firing pin assembly must drop into place under its own weight. Do not apply pressure to force firing pin assembly into bomb because assembly may deform and fire signal.

6. Rotate firing pin assembly so that the two U-shaped notches in the lip line

up with the two pin holes in the bomb nose. Do not apply pressure to firing pin during this operation.

7. Insert cotter pin through the nose holes and the recesses in the firing pin assembly.

8. Spread ends of cotter pin just enough to retain it in place.

CAUTION: Do not bend the ends of the cotter pin at a right angle to the axis of the cotter pin, or strike the ends to bend the cotter pin into position.

Section 11.14—25 lb. Practice Bomb Mk 76 Mod 3

Description

The 25 lb. Practice Bomb Mk 76 Mod 3 is capable of air burst firing or impact firing. This dual capacity is accomplished by providing a removable bushing. For impact firing, the bomb is assembled with a bushing, cotter pin, setscrew, firing pin, and signal, figure 11.38. For air burst firing, the bomb is assembled with a fuze, setscrew, and signal, shown by the assembly in figure 11.32.

The bomb has an elongated, teardrop-shaped body. The fin assembly is composed of four fin blades and a shroud welded to a center tube. A conical section covers the center tube and is threaded to the body section. The two sections are staked together to prevent unscrewing.

A cotter pin is inserted through the nose of the bomb to retain the firing pin assembly and signal. A setscrew is threaded into the nose of the bomb to retain the time fuze and signal. The signal is fired by the firing pin or by the time fuze. Smoke produced from the detonated signal is discharged rearward through the tube of the fin assembly.

CAUTION: Tests have shown that the fuze will fragment the bomb body producing a maximum fragment weight of 254 grams and a maximum fragment velocity of 98 feet per second. Proper precautions should be taken to ensure that any personnel who may be scoring drops of this bomb are beyond the maximum range of the burst.

A single suspension lug is threaded into the bomb body and cemented in place. Two $\frac{3}{8}$ inch indexing holes are drilled into the body at the center of gravity; to accommodate the Aero 8A Dispenser.

Identifying nomenclature is stenciled in white marking ink on the side of the body. The exterior surface of the bomb is coated

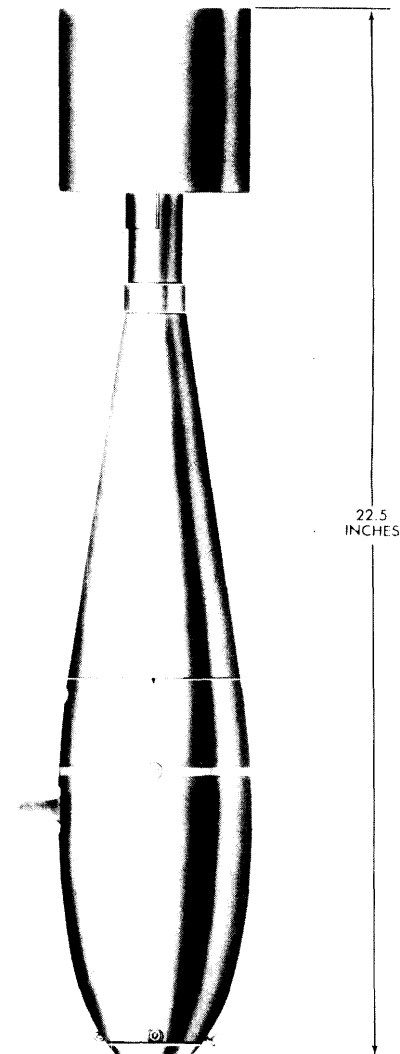
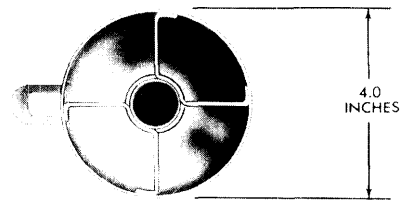

Figure 11.38—25 lb Practice Bomb Mk 76 Mod 3.

with black enamel. A ¼-inch white stripe is painted around the body at the center of gravity.

Physical Characteristics

Weight of assembled bomb with Signal Mk 4 Mod 3 and Firing Pin Mk 1 Mod 0	25.05 lbs
Weight of assembled bomb with Signal Mk 4 Mod 3 and AN-M146E3 Time Fuze	26.27 lbs
Weight of Signal Mk 4 Mod 3	0.16 lb
Weight of Firing Pin Mk 1 Mod 0	0.04 lb
Weight of AN-M146E3 Time Fuze	1.60 lbs
Dimensions:	
Length or height of assembled bomb with Signal Mk 4 Mod 3 and Firing Pin Mk 1 Mod 0	22.50 inches

Length or height of assembled bomb with Signal Mk 4 Mod 3 and AN-M146E3 Time Fuze	27.155 inches
Length of bomb body	7.78 inches
Diameter	4.00 inches
Fin span	4.00 inches
Length of fin assembly	14.50 inches
Suspension:	
Single suspension lug	center of gravity

**Components of a Complete Round
(Figures 11.39 and 11.40) Using
Firing Pin**

- Bomb body assembly (including):
 - Bomb body (with fin assembly)
 - Bushing
 - Cotter pin
 - Setscrew
 - Firing Pin Mk 1 Mod 0

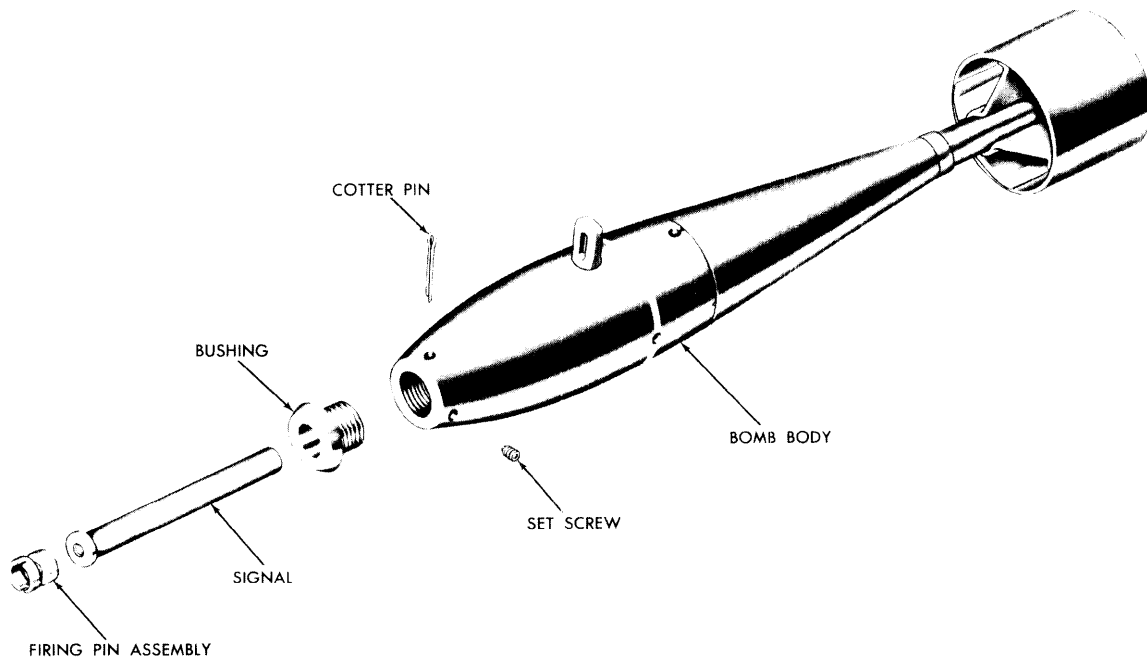

Figure 11.39—25 lb Practice Bomb Mk 76 Mod 3, Exploded View.

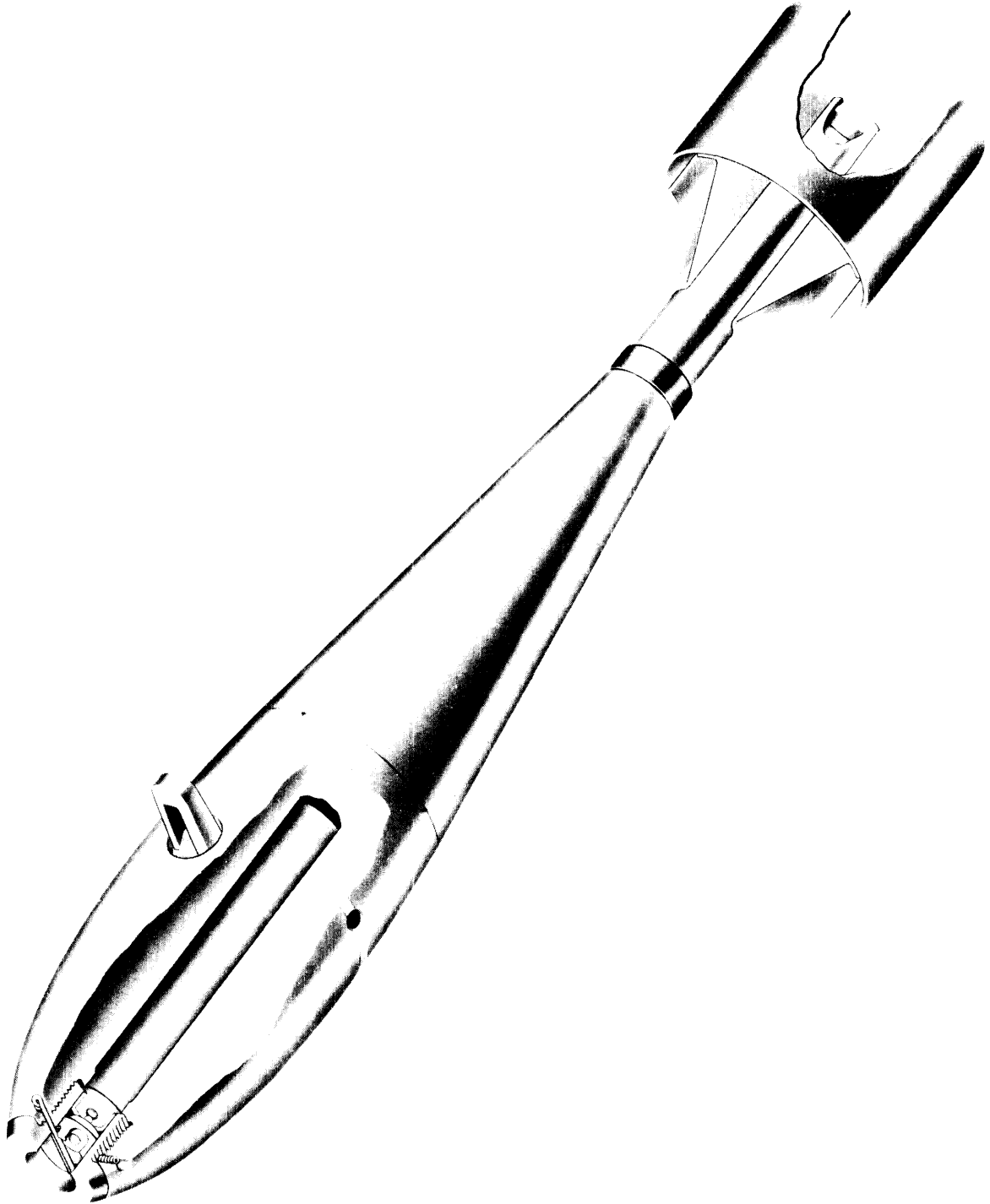

Figure 11.40—25 lb Practice Bomb Mk 76 Mod 3, Cutaway View.

Signal:

Practice Bomb Signal Mk 4 Mod 3

Components of a Complete Round Using Time Fuze

Bomb body assembly (including):

Bomb body (with fin assembly)

Setscrew

Signal:

Practice Bomb Signal Mk 4 Mod 3

AN-M146E3 Time Fuze

Arming wire

Fahnestock clip

Assembly

CAUTION: Signals, fuzes, and bombs shall not be unpacked in advance of requirements. If unpacked and not used, return them to their original packings.

Assembly Using Firing Pin Mk 1 Mod 0.

1. Remove bomb assembly from crate.
2. Remove required number of bombs and signals from their packings. Practice Bomb Mk 76 Mod 3 is shipped from the manufacturer with the bushing and firing pin installed and with a retaining cotter pin through the nose end.
3. Remove the cotter pin and firing pin assembly from the nose of the bomb.
4. Place bomb in a vertical position with nose end up.
5. Insert signal into bomb, primer end up, and let it gently slide into place. Do not use force. The base flange of the signal cartridge must rest on the bushing shoulder (about 1- $\frac{1}{4}$ inches from the nose of the bomb).

CAUTION: Signals must not be swollen or deformed in any manner. The primer must be flush or slightly below the base of the cartridge. Signal cartridges that are deformed in any way shall not be used.

6. Carefully insert firing pin assembly with firing pin end toward signal.

CAUTION: Firing pin assembly must fit loosely and not bind when dropped into position. Inspect firing pin assembly for damage. Be sure firing pin cup is not deformed and that the firing-pin point is below the lip of the cup. Check bore through center of bomb; bore must be smooth and clean, and not damaged in any way. Firing pin must drop into place under its own weight. Do not apply pressure to force firing pin assembly into bomb because assembly may deform and fire the signal.

7. Rotate firing pin assembly so that the two U-shaped notches in the lip line up with the two pin holes in the bomb nose. Do not apply pressure to firing pin during this operation.

8. Insert cotter pin through the nose holes and the recesses in the firing pin assembly.

9. Spread ends of cotter pin just enough to retain it in place.

CAUTION: Do not bend the ends of the cotter pin at a right angle to the axis of the cotter pin, or strike the ends to bend the cotter pin into position.

Assembly Using AN-M146E3 Time Fuze.

1. Remove bomb assembly from crate.
2. Remove and discard bushing.
3. Verify that setscrew is backed off sufficiently to permit entrance of fuze.
4. Place bomb in a vertical position with the nose end up.
5. Remove signal from packing and insert signal into bomb, primer end up, and let it gently slide into place. Do not use force. The base flange of the signal cartridge must rest on the bomb bore shoulder (about 1.0 inch from the nose of the bomb).

CAUTION: Signals must not be swollen or deformed in any manner. The primer must be flush or slightly below the base of the cartridge. Signal cartridges that are deformed in any way shall not be used.

6. Remove fuze from packing and inspect fuze to ensure that the fuze safety devices are in place. For detailed information on fuzing and defuzing, refer to OP 988 (First Revision).

CAUTION: If a fuze is armed or otherwise unsafe to handle, the fuze shall be disposed of by authorized personnel.

7. Carefully screw fuze into nose of bomb until seated, then back off a portion of one turn until arming pin is in line with suspension lug.

8. Tighten setscrew to lock fuze in place.

9. Install arming wire and Fahnestock clip.

CONFIDENTIAL

1

2

CONFIDENTIAL

CONFIDENTIAL

Chapter 12
FIRE BOMBS

Section 12.1—General

Section 12.2—750-lb Fire Bomb Mk 77 Mod 0

Section 12.3—750-lb Fire Bomb Mk 77 Mod 0 with Bomb Conversion Kit Mk 19 Mod 0

Section 12.4—500-lb Fire Bomb Mk 77 Mod 1

Section 12.5—750-lb Fire Bomb Mk 78 Mod 2

Section 12.6—1000-lb Fire Bomb Mk 79 Mod 0

CONFIDENTIAL

223-224

CONFIDENTIAL

CONFIDENTIAL

Chapter 12

FIRE BOMBS

Section 12.1—General

Description

A fire bomb, figure 12.1, is a thin-skinned container, made of either steel or aluminum. The bomb is filled with a gasoline gel and armed with igniters and fuzes which ignite the gasoline gel upon impact with the ground. Two igniters and fuzes are used with each bomb and are inserted in either brackets or fuze wells. Adapters or caps secure the igniters in place. The bombs are filled through holes which have gasket-sealed covers.

Fire Bombs Mk 77 and Mk 78 have no fins, but fins are provided on Fire Bomb Mk 79 to improve its separation characteristics when released at high speeds. Bomb Conversion Kit Mk 19 Mod 0 provides fins and a VT fuze adapter for the Fire Bomb Mk 77 Mod 0 to make this bomb applicable for use with dive bombing tactics.

Usage

Fire bombs are effective when used against dug-in troops, supply installations, wooden structures, and land convoys. For maximum target effect, the bombs are released at low altitudes to spread the burning gel over a large area. If released at high altitudes, the bombs dig craters which trap the gel, preventing it from spreading. However, Fire Bomb Mk 77 Mod 0, modified with the Bomb Conversion Kit Mk 19 Mod 0 and fuzed with the standard VT Fuze M166, minimizes the cratering effect and makes this bomb applicable for use from dive bombing attitudes and altitudes.

Fire Bombs

750-lb Fire Bomb Mk 77 Mod 0 and Bomb Conversion Kit Mk 19 Mod 0
 500-lb Fire Bomb Mk 77 Mod 1
 750-lb Fire Bomb Mk 78 Mod 2
 1000-lb Fire Bomb Mk 79 Mod 0

Fuzes Compatible with Fire Bombs

Fire bombs use igniters to ignite the gasoline gel. The following igniters and fuzes are used with fire bombs:

Igniter M15 with Fuze M157
 Igniter M16 with Fuze M157
 Igniter M23 with Fuze M173

Markings

Fire bombs are identified by standard nomenclature which is stenciled on the bomb and its components.

Purple stripes encircle the nose and tail ends. The overall color is olive drab or the original metal finish.

Suspension

Two lugs on the bomb body provide for a 14-inch suspension. For additional strength, the suspension lugs are attached to an inner support. Fire bombs may be suspended either on the aircraft while empty and then filled with gasoline gel, or filled with gasoline gel prior to suspension on the aircraft, depending on the procedure found to be most practicable.

Safety Precautions

Fire bombs and their components are shipped separately and are assembled in the field to form a complete round.

The handling and storing of Napalm thickener will be described in OP 2183 (under preparation).

Special care must be taken when handling the bomb sections to prevent denting or nicking the gasket seats. The bomb casing is damaged easily and should be handled carefully when uncrating and during installation.

For detailed safety procedures in handling and installing igniters and fuzes, refer to OP 988 (First Revision).

Safety Precautions To Be Observed

1. Igniters, bomb bodies or sections shall not be unpacked in advance of requirements.
2. Any fuzed igniter accidentally armed must be handled only by authorized personnel.
3. Igniters shall not be assembled to bomb in anticipation of future needs.
4. Guard igniters against dropping to prevent premature detonation.
5. Install igniters into wells or brackets carefully; never use a tool for installation, unless authorized.
6. Never remove safety cotter pins from fuzed igniters prematurely.
7. Replace all safety pins when defuzing a bomb.
8. Inspect arming wires for kinks, twists, or burrs. Such defects may cause a bomb to malfunction.
9. Once a fire bomb is filled, it must be used or destroyed. All bombs not expended shall be jettisoned prior to landing afloat or ashore.

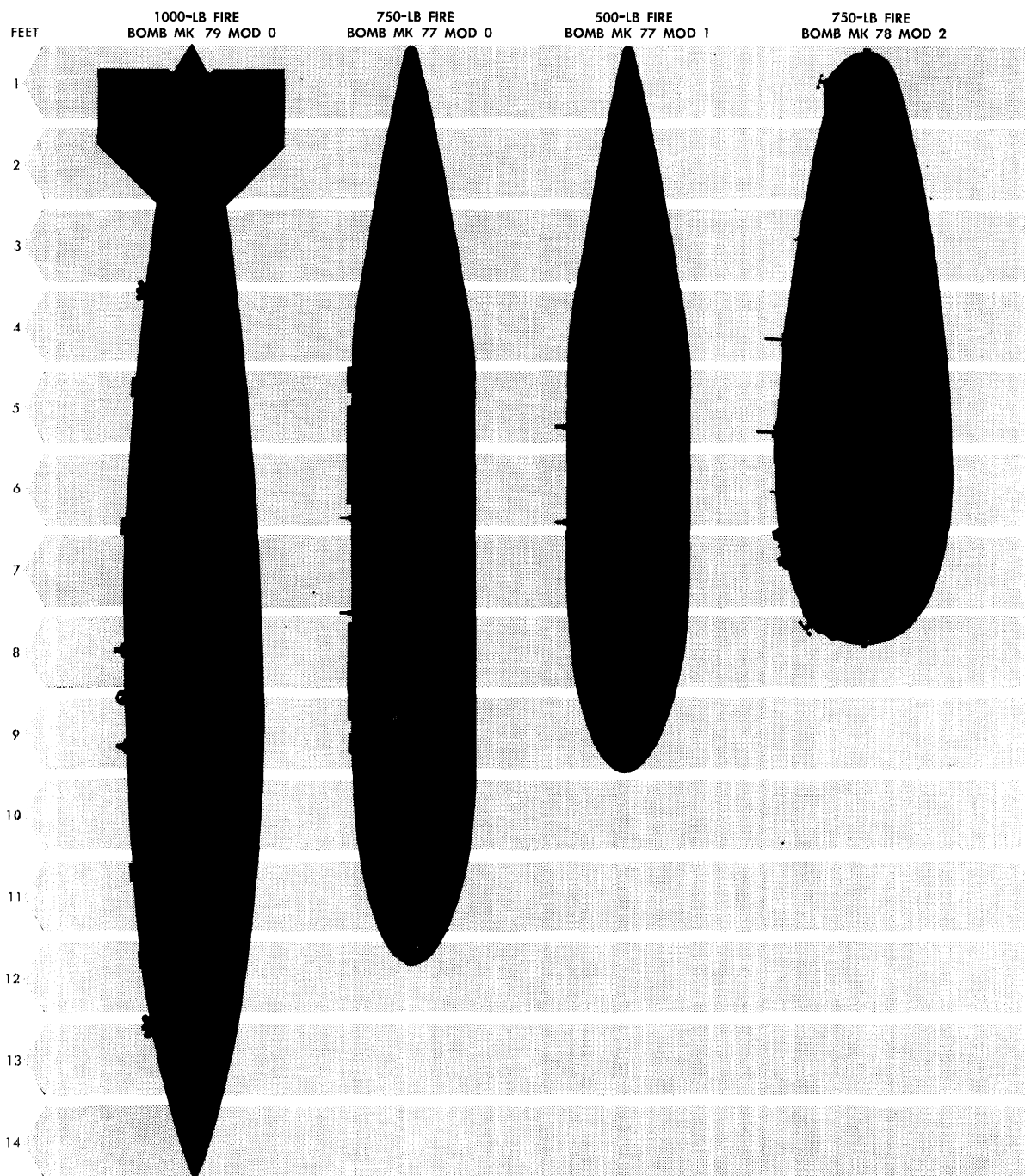

Figure 12.1—Fire Bombs, Comparative Size.

- Dimensions:
- Length or height of complete bomb 138.0 inches
 - Diameter 18.63 inches
- Suspension:
- Two suspension lugs 14 inches c to c

Components of a Complete Round (Figures 12.3 and 12.4)

- Bomb body assembly (including):
 - Bomb body (3 sections, nose and tail cones, and cone adapters)
 - Gaskets
 - Tie rod
 - Filler caps
- Igniters (two required):
 - M15
 - M16
 - M23
- Fuzes (two required):
 - M157 (Use with Igniters M15 and M16)
 - M173 (Use with Igniter M23)
- Arming wire assembly, double (two required)
- Fahnestock clips

Assembly

CAUTION: Igniters, fuzes, and bombs shall not be unpacked in advance of requirements. If unpacked and not

used, return them to their original packings.

1. Remove bomb body and its components from their packing crate as follows:
 - a. Remove eight screws securing end panel of bomb shipping crate.
 - b. Remove end panel of crate.
 - c. Cut four metal straps which secure bomb sections to crate.
 - d. Slide bomb sections out of the open end of the crate.
 - e. Remove and open package containing tie rods, washers, and nuts.
 - f. Remove tail cone from shipping crate end plate.
 - g. Check sealing gaskets. Gaskets must be in place, and sealing surfaces must be free of foreign matter, dents, and nicks.
 - h. Be sure that nose and tail sections include cones, cone adapters, shipping pins, igniter adapters, and filling hole covers.
 - i. Check suspension lugs for damage.
2. Remove tail-cone screws from tail-cone adapter.
3. Pull shipping pin from clevis pin in tail-cone adapter, and remove clevis pin and clevis-pin spring to release tail-cone adapter.
4. Remove igniter adapter from tail end-plate casting.

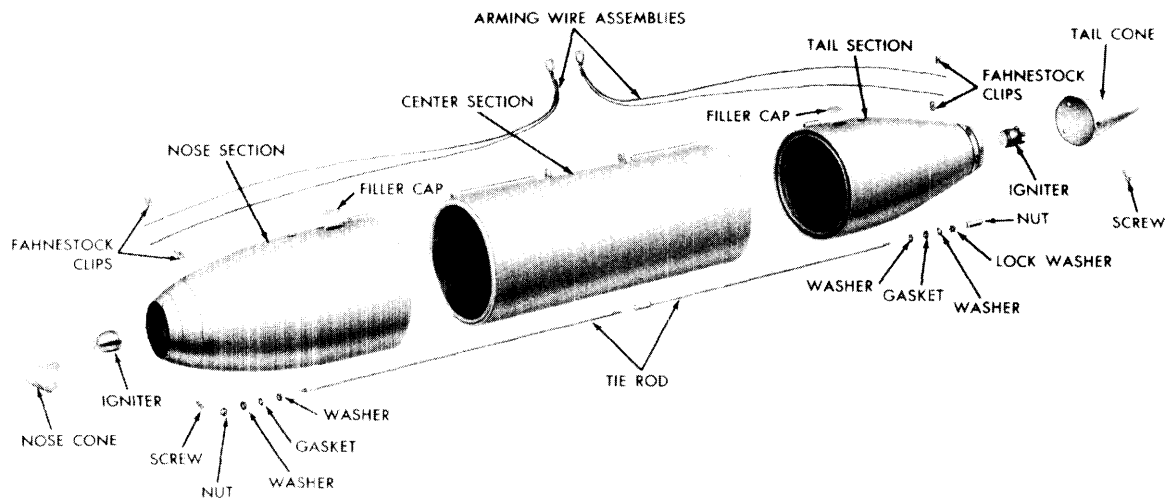

Figure 12.3—750-lb Fire Bomb Mk 77 Mod 0, Exploded View.

Section 12.2—750-lb Fire Bomb Mk 77 Mod 0

Description

The 750-lb Fire Bomb Mk 77 Mod 0, figure 12.2, is a non-stabilized, cigar-shaped bomb constructed of aluminum. It consists of three main sections and two end cones. A center tie-rod holds the nose, center, and aft sections together; aluminum ring adapters secure the nose and tail cones to the main sections. The bomb is filled with 110 gallons of gasoline gel and uses two igniter and fuze combinations to ignite the gel upon impact.

Three igniters may be used with Fire Bomb Mk 77 Mod 0; they are: Igniters M15, M16, or M23. The bomb is designed for the primary use of Igniter M23. Adapters are furnished with the bomb so that igniter M15 may be used for either nose or tail fuzeing. Igniter M16 is used only for tail fuzeing. When the bomb is assembled, one igniter is attached to each end of the bomb.

Tubes carry the arming wires and cone release wires from the outside of the bomb to the inside. When the release wires are withdrawn, springs in the ring adapters eject both adapters and cones.

Double suspension lugs are mounted 14 inches apart. Identifying nomenclature is stenciled on the body assembly.

Two gasket-sealed filler holes are located on the upper side of the bomb body. Gaskets between the three main sections prevent leakage of the gasoline gel.

A gasoline and Napalm mixture (gel) fills the bomb body. A minimum air space of 3 percent of the bombs capacity is required. Once a bomb is filled, it cannot be disassembled; it must be used or jettisoned.

Physical Characteristics

- Weight of assembled fuzeed bomb:
 - Loaded with gasoline 750 lbs
 - gel
- Weight of empty bomb . . . 82 lbs
- Weight of bomb and 138 lbs
- crate as shipped
- Capacity of gasoline gel . . . 110 gallons

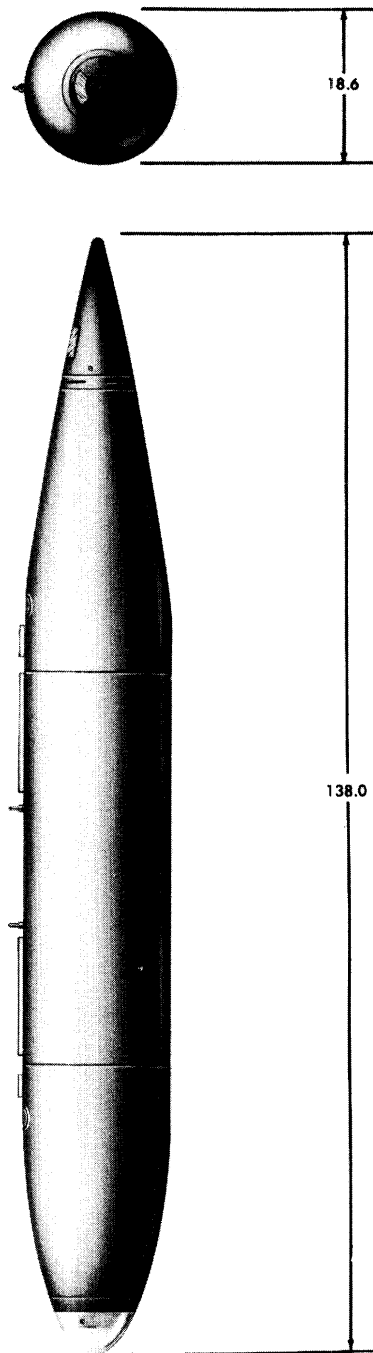

Figure 12.2—750-lb Fire Bomb Mk 77 Mod 0.

5. Remove nose cone.
6. Release nose-cone adapter as described in the preceding step 3.
7. Remove igniter adapter from nose-plate casting.
8. Wipe gasket surfaces on all sections with carbon tetrachloride or gasoline.
9. Assemble tie rod sections. Screw the ends of the forward and rear tie rods (which have a one-inch length of thread) into the center nut, until the tie rods come together.
10. Pass end of the tie rod with the shortest end of threads through the hole in the nose end-plate casting. Slide large inside-diameter washer over end of tie rod and fit into recess; place gasket, small inside-diameter flat washer, lock washer, and self-locking nut on the tie rod (in order given). Secure by tightening self-locking nut on tie rod.
11. Pass tie rod assembly through center section.
12. Move tail section into position; remove rear filler cap, reach through filling hole and guide tie rod through hole in tail end-plate casting.
13. Slide large inside-diameter washer over end of tie rod and fit into recess; place gasket, small inside-diameter washer, lock washer, and long nut on tie rod (in order given). Be sure the counterbored end of nut is placed over the tie rod first.
14. Align arming wire tubes on all sections.
15. Secure tie rod with the long nut, and tighten with torque wrench to 325 inch-pounds.
CAUTION: Before tightening long nut, be sure that gaskets on tie rod are seated properly.
16. Screw igniter adapter in nose end-plate casting, until it bottoms.
17. Replace nose-cone adapter, clevis-pin spring, and clevis pin. Replace shipping pin to secure assembly. Check nose-cone adapter release mechanism by pulling out shipping pin.
18. Reassemble nose-cone adapter and assemble nose cone.
CAUTION: Do not damage nose cone by tightening screws excessively.
If bomb is not to be used immediately, nose

cone need not be assembled to nose-cone adapter until bomb is fuzed.

19. Screw igniter adapter into tail end-plate casting, until it bottoms.

20. Replace tail-cone adapter by following a procedure similar to that previously described in steps 17 and 18.

21. The 750-lb Fire Bomb Mk 77 normally is loaded on the aircraft while empty, and then filled with gasoline gel. This procedure is not always practical. Detailed instructions for mixing the gasoline gel and filling the bomb will be given in OP 2183 (under preparation).

22. Fill bombs through either one or both filling holes; both covers must be removed even if filled through one hole. Secure covers after filling.

23. Install bomb securely on aircraft and sway brace. After the bomb is installed and filled, fuze and arm the bomb as follows:

- a. Remove screws securing nose cone to adapter, and remove nose cone.
- b. Thread two nose arming wires through suspension fitting and arming wire guide tubes to the nose end-plate casting.
- c. Insert one wire through hole in end of clevis pin.
- d. Attach arming wire to bomb rack.
- e. Remove clevis-pin shipping pin.
- f. Repeat steps a through e to install rear arming wires.
- g. Install nose and tail igniters.
- h. Insert arming wires into nose and tail fuzes.
- i. Attach Fahnestock clips to the ends of each fuze arming wire. Cut off excess arming wire.

CAUTION: Remove all kinks, twists, or burrs from arming wires to prevent possible malfunctioning.

j. Remove safety pins from igniter fuzes.

k. Install nose and tail cones and secure with screws. Do not tighten screws excessively.

24. Only an unfilled bomb may be disassembled.

CAUTION: Once filled, a bomb must be used or jettisoned.

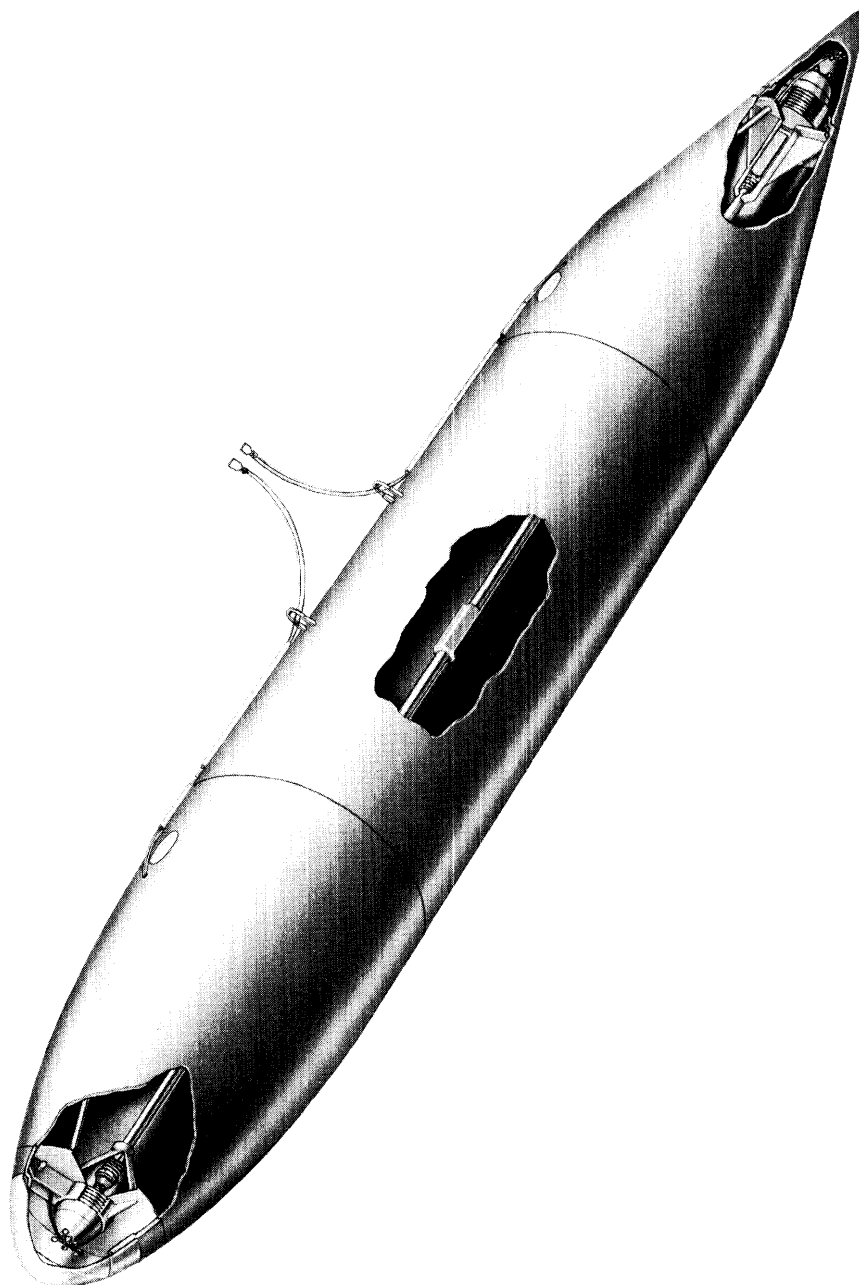

Figure 12.4—750-lb Fire Bomb Mk 77 Mod 0, Cutaway View.

Tie rod
 Filler caps
 Igniter adapters
 Nose fuze:
 VT Fuze M166E1
 Igniters (one of):
 M15
 M16
 M23
 Fuzes (one of):
 M157 (Use with Igniter M15 or M16)
 M173 (Use with Igniter M23)
 Bomb Conversion Kit Mk 19 Mod 0 (including):
 Fin and shroud components
 Fin assembling screws, washers, locking nuts, and safety wire
 Seal, O-rings (spare parts)
 Setscrews
 VT fuze adapter
 Arming wire assembly, double (two required)
 Fahnestock clips

Assembly

CAUTION: Igniters, fuzes, and bombs shall not be unpacked in advance of requirements. If unpacked and not used, return them to their original packings.

1. Remove bomb components from their packing crate as follows:
 - a. Remove eight screws securing end panel of bomb shipping crate.
 - b. Remove end panel of crate.
 - c. Cut four metal straps which secure bomb sections to crate.
 - d. Slide bomb sections out of the open end of the crate.
 - e. Remove and open package containing tie rods, washers, and nuts.
 - f. Remove tail cone from shipping crate end plate.
 - g. Check sealing gaskets. Gaskets must be in place and sealing surfaces free of foreign matter, dents, and nicks.
 - h. Be sure that nose and tail sections include cones, cone adapters, shipping pins, igniter adapters, and filling hole covers.
 - i. Check suspension lugs for damage.

2. Remove tail cone screws from tail-cone adapter.
3. Pull shipping pin from clevis pin in tail-cone adapter and remove clevis pin and clevis-pin spring to release tail-cone adapter.
4. Remove igniter adapter from tail end-plate casting.
5. Remove and discard nose cone.
6. Release nose-cone adapter as described previously in step 3 and discard.
7. Remove igniter adapter from nose plate casting.
8. Remove four bolts, washers, O-ring seals, and nuts from the tail section skin of the bomb. Inspect the O-ring seals, and if damaged, replace with the ones furnished with the conversion kit.
9. Remove the eight bolts, washers, and the safety wire from the fin mounting holes in the tail end-plate casting.
10. Mount the four fins from the conversion kit to the tail section using the screws, washers, and nuts removed in the preceding steps 8 and 9. Be sure that the O-ring seals seat properly at the bolts passing through the tail section skin. The O-ring seals should be next to the bomb skin with the large flat washer on top so that the washer contains the O-ring seal.
11. Secure the four sections of the tail fin shroud to the fins with the eight screws, washers, and locking nuts contained in the conversion kit.
12. Safety wire the eight fin securing bolts in the tail end-plate casting.
13. Wipe gasket surfaces on the three body sections with carbon tetrachloride or gasoline.
14. Assemble tie rod sections. Screw the ends of the forward and rear tie rods (which have a one-inch length of thread) into the center nut, until the tie rods come together.
15. Pass end of tie rod with the shortest end of threads through the hole in the nose end-plate casting. Slide large inside-diameter washer over end of tie rod and fit into recess; place gasket, small inside-diameter flat washer, lock washer, and self-locking nut on the tie rod (in order given). Secure by tightening self-locking nut on tie rod.
16. Pass tie rod through center section.
17. Move tail section into position. Remove rear filler cap, reach through filling hole, and

Section 12.3—750-lb Fire Bomb Mk 77 Mod 0 with Bomb Conversion Kit Mk 19 Mod 0

Description

Bomb Conversion Kit Mk 19 Mod 0 consists of component parts for a shrouded fin assembly, an adapter for VT Fuze M166E1, and two setscrews to lock in place the igniter clamp which holds the VT fuze adapter. The conversion kit was developed to convert the 750-lb Fire Bomb Mk 77 Mod 0 into a weapon that could be used in normal dive bombing tactics.

Bomb Mk 77 Mod 0 modified with Conversion Kit Mk 19 Mod 0 is stabilized during flight by a shrouded fin assembly. VT Fuze M166E1, housed in the nose of the bomb, functions prior to impact to rupture the nose casting of the bomb and free the tie rod that holds the three main body sections together. The bomb sections remain intact until impact when the gasoline gel is distributed over a greater area and a smaller crater is created than when the sections remain attached on impact.

The nose cone and nose-cone adapter ring are discarded when the VT fuze is installed. The use of a tail cone and tail-cone adapter ring are optional with the converted Bomb Mk 77 Mod 0.

Physical Characteristics

- Weight of assembled fuzed bomb:
 - Loaded with gasoline gel 750 lbs
- Weight of empty bomb 82 lbs
- Weight of bomb and crate as shipped 138 lbs
- Weight of bomb conversion kit as shipped 24 lbs
- Capacity of gasoline gel 110 gallons
- Dimensions:
 - Length or height of complete bomb:
 - With tail cone intact 138 inches
 - Without tail cone 131 inches
 - Diameter 18.63 inches
 - Fin span 31.75 inches
- Suspension:
 - Two suspension lugs 14 inches c to c

Components of a Complete Round (Figure 12.5)

- Bomb body assembly (including):
 - Bomb body (3 sections, nose and tail cones, and cone adapters) (nose cone and nose-cone adapter to be discarded)
 - Gaskets

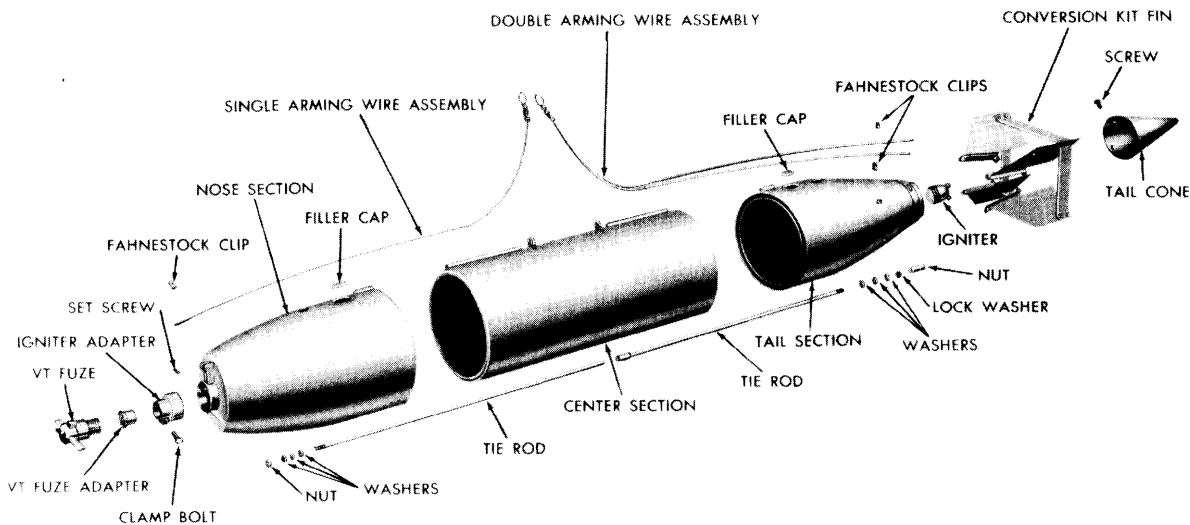

Figure 12.5—750-lb Fire Bomb Mk 77 Mod 0 with Bomb Conversion Kit Mk 19 Mod 0, Exploded View.

Section 12.4—500-lb Fire Bomb Mk 77 Mod 1

Description

The 500-lb Fire Bomb Mk 77 Mod 1, figure 12.6, is a 75-gallon capacity bomb obtained by modifying Fire Bomb Mk 77 Mod 0. The modification of Bomb Mk 77 Mod 0 consists of cutting approximately two inches off the nose and tail body sections and approximately 12 inches from each end of the center section. These modified sections are welded together to give a 75-gallon capacity, 500-lb bomb.

Igniters and fuzes are used in the nose and tail of Fire Bomb Mk 77 Mod 1. Three igniters, M15, M16, and M23, may be used. The bomb is designed for primary use of Igniter M23 with Fuze M173 in both the nose and tail. Adapters are furnished with the bomb so that Igniter M15 with Fuze M157 can be used in the nose or tail of the bomb. Igniter M16 with Fuze M157 can be used in the tail of the bomb only, because the nose cone will not accommodate this larger igniter.

The arming wires and cone release wires are carried to the nose and tail of the bomb through internal tubes. When the cone release wires are withdrawn, the springs in the cone ring adapters eject both nose and tail cones from the bombs, exposing the fuzes to the airstream.

Two suspension lugs are mounted on the body 14 inches apart. Identifying nomenclature is stenciled in red letters on the modified bomb body.

Two gasket-sealed filler holes are located on the upper bomb surface. The bomb is filled with 75 gallons of gasoline gel. A minimum air space of 3 percent of the bomb capacity is required. Once a bomb is filled, it cannot be disassembled; it must be either used or jettisoned.

Physical Characteristics

Weight of assembled fuzeed bomb:

 Loaded with gasoline
 gel..... 500 lbs

Weight of empty bomb... 63 lbs

Capacity of gasoline gel... 75 gallons

Dimensions:

 Length or height of
 complete bomb..... 108.6 inches

 Diameter..... 18.63 inches

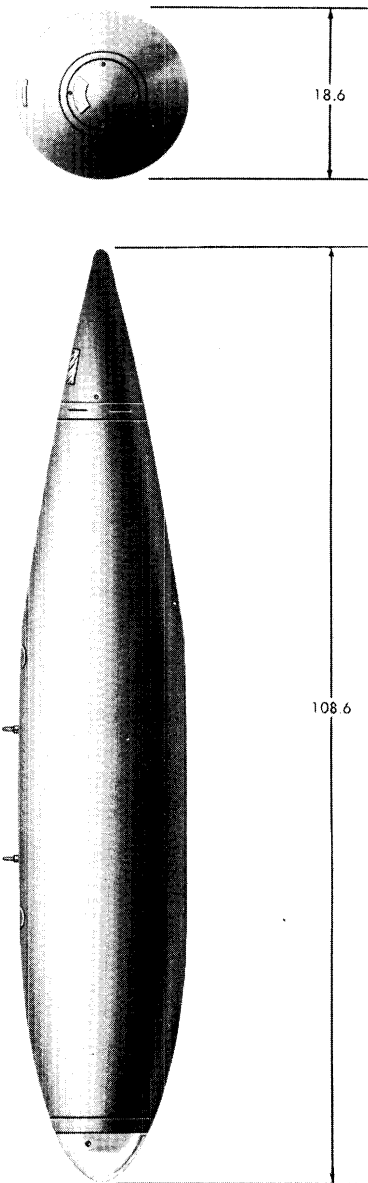

Figure 12.6—500-lb Fire Bomb Mk 77 Mod 1.

guide tie rod through hole in tail end-plate casting.

18. Slide large inside-diameter flat washer, lock washer, and long nut on tie rod (in order given). Be sure that the counterbored end of the nut is facing inward.

19. Align arming wire tubes on all sections and tighten long nut with torque wrench to 325 inch-pounds.

CAUTION: Before tightening long nut be sure that gaskets on tie rod are seated properly.

20. In the igniter-adapter seat of the nose end-plate casting, drill and tap two holes, 1/4 x 20, on opposite sides of casting flange. Screw the igniter adapter into the nose end-plate casting and lock in place with two headless setscrews supplied with Conversion Kit Mk 19 Mod 0.

21. Install VT fuze adapter in igniter adapter and tighten in place with the clamping bolt on the igniter adapter.

22. Screw igniter adapter into tail end-plate casting, until it bottoms.

23. Replace tail-cone adapter, clevis-pin spring, and clevis pin. Replace shipping pin to secure assembly. Check tail-cone adapter release mechanism by pulling out shipping pin.

24. Reassemble tail-cone adapter, and assemble tail cone.

CAUTION: Do not damage tail cone by tightening screws excessively.

If bomb is not to be used immediately, tail cone need not be assembled to tail-cone adapter, until bomb is fuzed.

25. The 750-lb Fire Bomb Mk 77 Mod 0 normally is loaded on the aircraft while empty, and then filled with gasoline gel. This procedure is not always practical. Detailed instructions for mixing the gasoline gel and filling the bomb will be given in OP 2183 (under preparation).

26. Fill bombs through either one or both filling holes; both covers must be removed even

if filled through one hole. Secure covers after filling.

27. Install bomb securely on aircraft and sway brace. After the bomb is installed and filled, fuze and arm the bomb as follows:

a. Remove screws securing tail cone to adapter, and remove tail cone.

b. Thread two tail arming wires through the rear suspension lug and the arming wire guide tubes to the tail end-plate casting.

c. Insert one wire through hole in end of clevis pin.

d. Attach arming wire to bomb rack.

e. Remove clevis-pin shipping pin.

f. Install igniter and fuze into tail igniter adapter. Refer to OP 988 (First Revision) for details on fuzing.

g. Insert arming wire into fuze and attach Fahnestock clips to the end of the wire. Replace tail cone and secure in place as described previously in step 24.

h. Remove VT Fuze M166E1 from its packings.

CAUTION: If fuze container is damaged or if the seal is broken in any way, the fuze shall be considered un-serviceable.

i. For instructions on installing VT Fuze M166E1, refer to instruction card (Dwg 1380254) which is attached to the VT fuze adapter in Conversion Kit Mk 19 Mod 0. Also refer to OP 1444 (Second Revision).

j. Thread a single arming wire through the front suspension lug and arming wire guide tubes to the nose end-plate casting.

k. Pass the arming wire through the VT fuze arming wire guides and attach one Fahnestock clip to the end of the wire.

l. Cut off excess wire at nose and tail fuze installations.

CAUTION: Arming wires must be free from kinks, twists, and burrs to prevent possible malfunctioning.

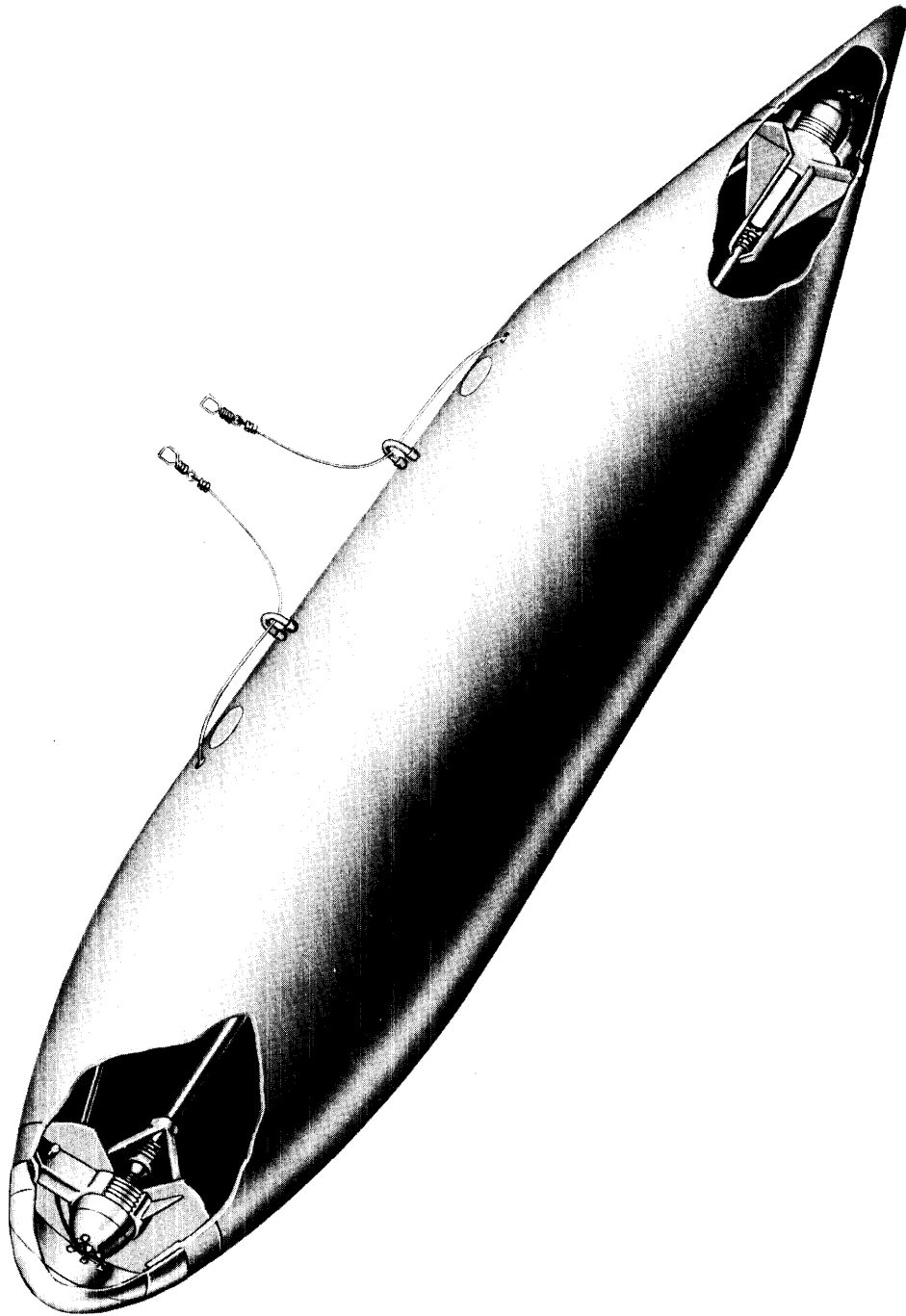

Figure 12.8—500-lb Fire Bomb Mk 77 Mod 1, Cutaway View.

Suspension:

Two suspension lugs --- 14 inches c to c

Components of a Complete Round (Figures 12.7 and 12.8)

Bomb body assembly (including):

Bomb body (welded body section, nose and tail cones, and cone adapters)

Filler caps

Igniters (two required):

M15

M16

M23

Fuzes (two required):

M157 (Use with Igniters M15 and M16)

M173 (Use with Igniter M23)

Arming wire assembly, double (two required)

Fahnestock clips

1. Check bomb for damage (broken weldments, cracks, etc.) that may weaken the suspension or cause leaks in the casing.

2. Check nose and tail sections for presence of cones, cone ring adapters, shipping pins, igniter adapters, and filling hole covers.

3. Remove tail-cone screws from tail-cone adapter.

4. Pull shipping pin from clevis pin in tail-cone adapter, and remove clevis pin and clevis-pin spring to release tail-cone adapter.

5. Remove igniter adapter from tail end-plate casting.

6. Remove nose cone.

7. Release nose-cone adapter as described previously in step 4.

8. Remove igniter adapter from nose end-plate casting.

9. Screw igniter adapter in nose end-plate casting, until it bottoms.

10. Replace nose-cone adapter, clevis-pin spring, and clevis pin. Replace shipping pin to secure assembly. Check nose-cone adapter release mechanism by pulling out shipping pin.

11. Reassemble nose-cone adapter, and assemble nose cone.

CAUTION: Do not damage nose cone by tightening screws excessively.

Assembly

NOTE: The following assembly instructions do not describe the uncrating or physical modification details for converting Bomb Mk 77 Mod 0 to Mk 77 Mod 1. For unpacking of Fire Bomb Mk 77 Mod 0, refer to section 12.2.

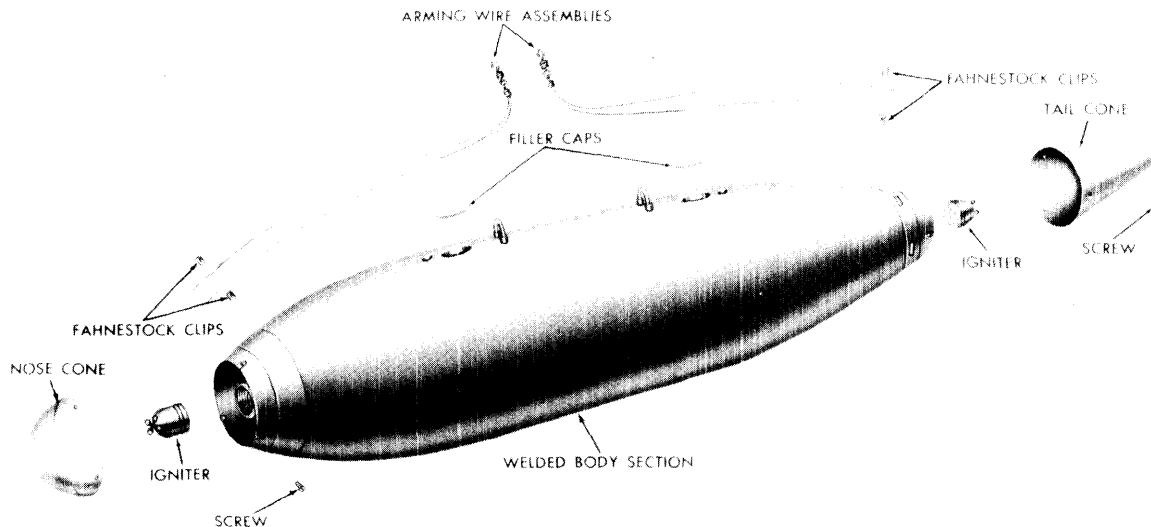

Figure 12.7—500-lb Fire Bomb Mk 77 Mod 1, Exploded View.

Section 12.5—750-lb Fire Bomb Mk 78 Mod 2

Description

The 750-lb Fire Bomb Mk 78 Mod 2, figure 12.9, is a nonstabilized, 110-gallon capacity bomb consisting of two thin sheet-steel half-shells welded together.

The bomb has two fuze wells located fore and aft on the upper surface. The wells house two Igniters M23 which are located in place with igniter caps. A filler opening for the gasoline gel is located on the upper surface of the bomb between the fore igniter well and the suspension lugs.

Two reinforced lugs provide for a 14 inch suspension. The 750-lb Fire Bomb Mk 78 is identified by a purple stripe painted on the nose and tail end of the body. Identifying nomenclature is stenciled in black letters. The base color of the bomb is olive drab.

A gasoline and Napalm mixture (gel) fills Fire Bomb Mk 78 Mod 2 to 97 percent of its capacity. Once a fire bomb is filled, it cannot be disassembled; it must be used or jettisoned.

Differences Between Fire Bomb Mk 78 Mods 0, 1, and 2

There are three modifications of the 750-lb Fire Bomb Mk 78 currently used by the armed services: Mod 0, Mod 1, and Mod 2. Differences exist in the construction and location of wells, brackets, and adapters for use of Igniters M15, M16, and M23.

Fire Bomb Mk 78 Mod 0 uses Igniter M16 with Fuze M157 installed in the filler hole of the bomb. A second igniter, M15 with Fuze M157, is clamped externally to the aft end of the bomb in a bracket.

Fire Bomb Mk 78 Mod 1 is identical to the Mod 0 with the exception of the addition of two external igniter adapters. The igniter adapters, located fore and aft on the upper bomb surface, accommodate Igniters M23 with Fuzes M173.

Fire Bomb Mk 78 Mod 2 is identical to the Mod 1 except that it has internal igniter wells in place of the external igniter adapters. The wells of the Mod 2 are located higher on the bomb body than the igniter adapters of

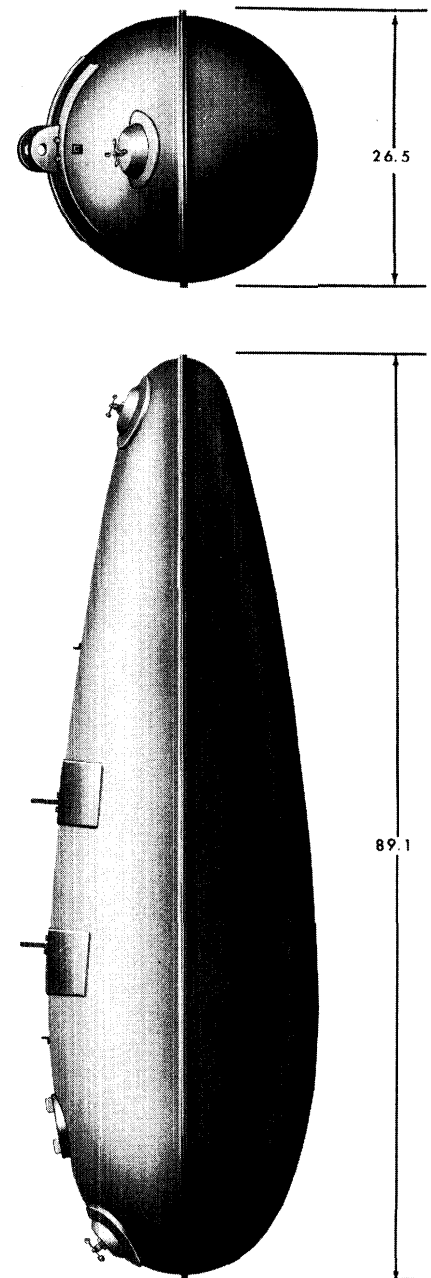

Figure 12.9—750-lb Fire Bomb Mk 78 Mod 2.

If bomb is not to be used immediately, nose cone need not be assembled to nose-cone adapter until bomb is fuzed.

12. Screw igniter adapter into tail end-plate casting, until it bottoms.

13. Replace tail-cone adapter following a procedure similar to that described in the preceding steps 10 and 11.

14. The 500-lb Fire Bomb Mk 77 Mod 1 normally is loaded on the aircraft while empty, and then filled with gasoline gel. This procedure is not always practical. Detailed instructions for mixing the gasoline gel and filling the bomb will be given in OP 2183 (under preparation.)

15. Fill bombs through either one or both filling holes; both covers must be removed even if filled through one hole. Secure covers after filling.

16. Install bomb securely on aircraft and sway brace. After the bomb is installed and filled, fuze and arm the bomb as follows:

a. Remove screws securing nose cone to adapter, and remove nose cone.

b. Thread two nose arming wires through

suspension fittings and internal wire-guide tube to the nose end-plate casting.

c. Insert one wire through hole in end of clevis pin.

d. Attach arming wire to bomb rack.

e. Remove clevis-pin shipping pin.

f. Repeat the preceding steps a through e to install rear arming wires.

g. Install nose and tail igniters.

h. Insert arming wires into nose and tail fuzes.

i. Attach Fahnestock clips to the ends of each fuze arming wire. Cut off excess arming wire.

CAUTION: Remove all kinks, twists, and burrs from arming wires to prevent possible malfunctioning.

j. Remove safety pins from igniter fuzes.

k. Install nose and tail cones and secure with screws. Do not tighten screws excessively.

17. Only an unfilled bomb may be disassembled.

CAUTION: Once filled, a bomb must be used or jettisoned.

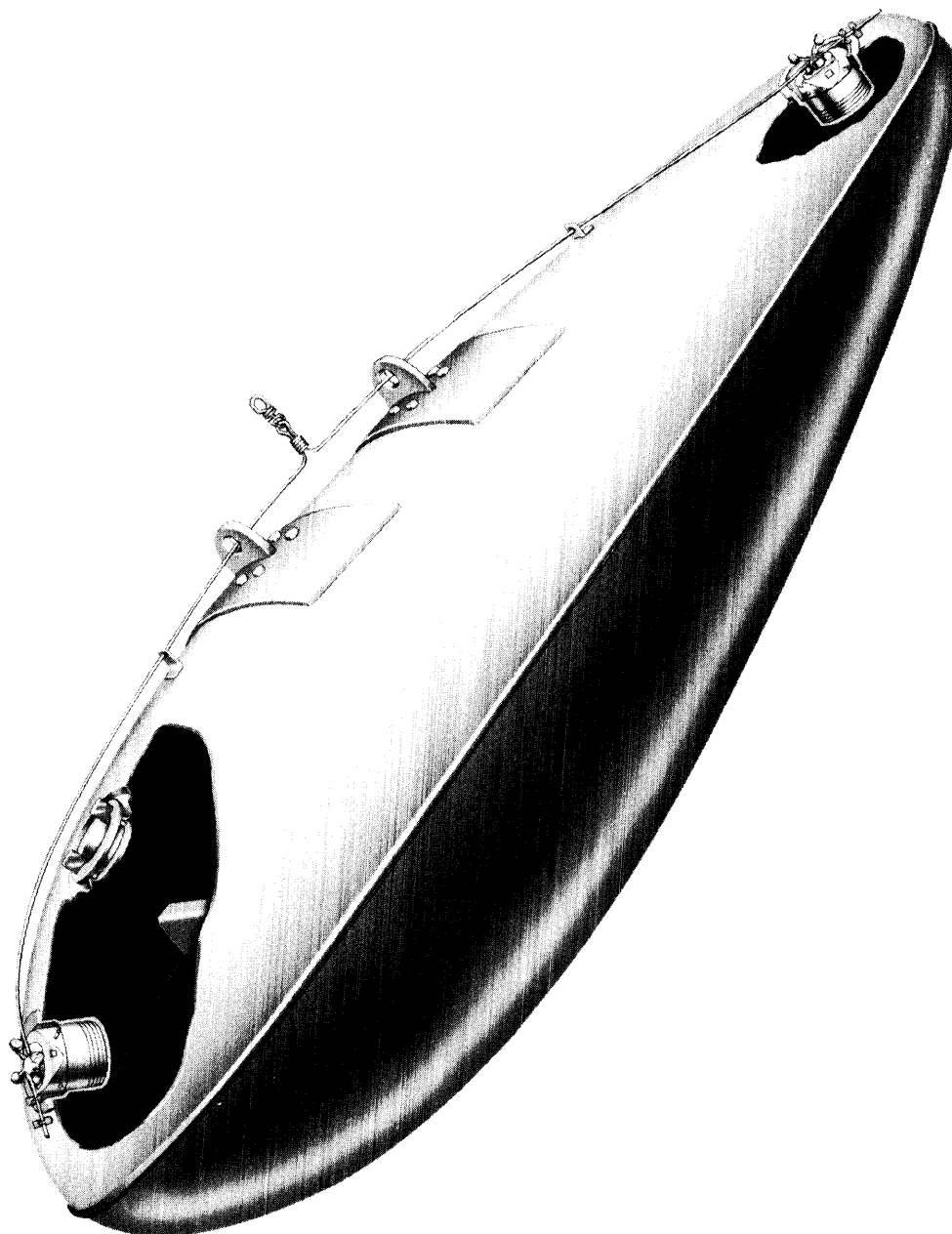

Figure 12.11—750-lb Fire Bomb Mk 78 Mod 2, Cutaway View.

might cause leaks in the bomb body or damage that might weaken lugs or their attachment to the bomb body.

2. Fill bomb to required capacity through filler hole. Secure cover after filling.

3. Detailed instructions for mixing the gasoline gel and filling the bomb will be given in OP 2183 (under preparation).

4. Install bomb securely on aircraft and sway brace. This bomb normally is loaded on the aircraft while empty, and then filled with gasoline gel. However, this procedure is not always practical.

5. After the bomb is suspended from the bomb rack and filled, fuze and arm the bomb as follows:

a. Loosen bolt on rear igniter clamp.

b. Install Igniter M15 and tighten clamp bolt, until signal is secure.

c. Install Igniter M16 in filler hole.

d. On Mod 2, disregard the preceding steps a, b, and c. Remove igniter well caps and install Igniter M23. Replace well caps, securing igniters. On Mod 1, install Igniters M23 in external adapters.

e. Thread arming wire through suspension fittings and arming wire guide brackets.

f. Attach arming wire to bomb rack.

g. Insert arming wires into nose and tail fuzes.

h. Attach Fahnestock clips to the ends of each igniter arming wire; arming wire should protrude approximately 2 inches beyond fuze vanes (cut off excess wire) and should be free from all kinks, twists, or burrs.

i. Remove safety pins from igniter fuzes.

6. Only an unfilled bomb may be disassembled. Once filled, the bomb must be used or destroyed; all bombs not used shall be jettisoned prior to landing afloat or ashore.

12.10 and 12.11)

Bomb body assembly (including):
Bomb body

from their packing crate.

CAUTION: Inspect for damage (cracks, broken weldments, etc.) which

Section 12.6—1000-lb Fire Bomb Mk 79 Mod 0

Description

The 1000-lb Fire Bomb Mk 79 Mod 0, figure 12.12, is a thin-skinned, collapsible bomb of low-drag design. It consists of four basic sections; nose, main, aft, and tail; which telescope together. The first three sections are constructed of sheet steel; the fourth section is a void space and is constructed of aluminum. Rubber fuel-resistant gaskets seal the joints between all sections. Detachable aluminum fins are installed on the tail section to provide stability during flight.

Bomb Mk 79 Mod 0 is filled with 115 gallons of gasoline mixed with Napalm. A void of at least three percent of the bomb capacity is required. The gel is ignited upon impact by two Igniters M23 and Fuzes M173 installed in sunken igniter wells on the upper surface of the nose and tail sections.

Two screw-in suspension lugs are provided in the center body section 14 inches apart. A single hoisting lug is welded midway between the suspension fittings. Once the telescoping sections of Fire Bomb Mk 79 Mod 0 are extended and locked, the bomb cannot be disassembled. When the bomb is filled, it must be used or jettisoned.

Physical Characteristics

Weight of assembled fuzed bomb:

Loaded with gasoline 895 lbs
gel

Weight of assembled 185 lbs
empty bomb

Shipping weight of bomb 245 lbs

Capacity of gasoline gel 115 gallons

Dimensions:

Length of assembled 168.3 inches
bomb

Length of bomb as 68.6 inches
shipped

Diameter of assembled 19.6 inches
bomb

Diameter as shipped 23.3 inches

Suspension:

Two suspension lugs 14 inches c to c

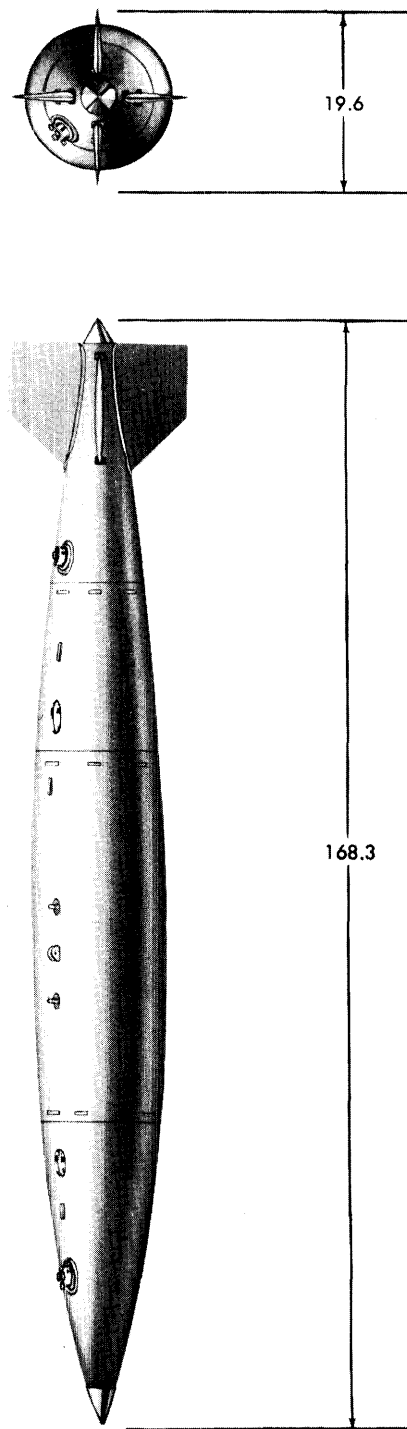

Figure 12.12—1000-lb Fire Bomb Mk 79 Mod 0.

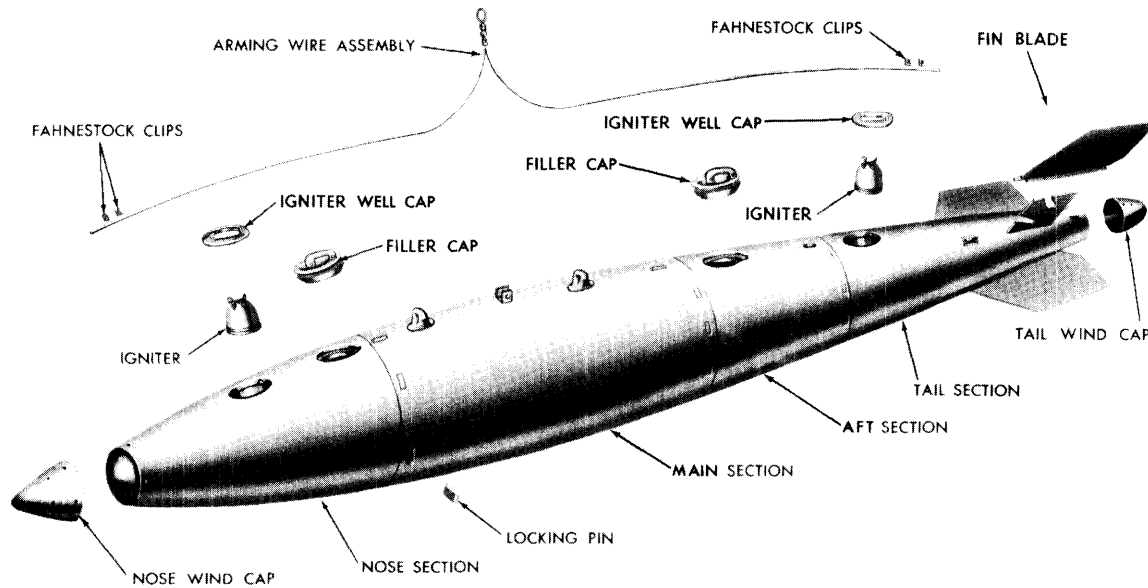

Figure 12.13—1000-lb Fire Bomb Mk 79 Mod 0, Exploded View.

Components of a Complete Round (Figures 12.13 and 12.14)

- Bomb body assembly (including):
 - Bomb body (4 telescoping sections)
 - Igniter well caps
 - Locking pins
 - Nose and tail wind caps
 - Filler caps
 - Fin blades
- Igniters (two required):
 - M23 with Fuze M173
- Arming wire assembly
- Fahnestock clips

Unpacking

1. Lay the bomb on its side, and place it on a bomb truck, hand truck, dolly, or other support, so that the shipping ends are free of the ground. Block the bomb in place to prevent rolling.

2. The bomb may be unpacked, however, on any hard, reasonably smooth surface, such as a deck or flight apron. If this is done, do not allow the bomb to fall when the projecting shipping ends are removed.

3. Inspect the packaged bomb for visible damage to the Number II (center) section.

Some damage to the shipping ends is to be expected.

4. Using a screwdriver, pry up the four lever handles on the nose shipping end, until they release. After these handles are released, grasp each one in turn and rotate the attached shafts one-half turn (it may be necessary to push the handle in towards the face of the cover while turning). Turning the handle will release an internal hook attached to the handle shaft; when properly unhooked, there will be no restraint from turning the handle.

5. When (and only when) the four internal hooks are released, remove the nose cover and the gasket at the edge of this cover. It may be necessary to use a hammer.

6. Attached to the inside of the nose cover are a cone-shaped nose cap and a smaller tail cap. Remove these caps from their holding brackets, by inserting a screwdriver tip into one of the holes in the side of the bracket and depressing the spring pin on the cap. When the caps have been removed, the nose cover may be discarded.

7. Reach into the bomb, grasp the forward end of the Number I (nose) section and move it up and down or side to side until it is free; pull it forward about one foot. DO NOT SLAM

OR JERK THE SECTION; PULL FIRMLY AND EVENLY. Wiggle the section from side to side if friction occurs.

CAUTION: Do not perform the removal of the tail cover (step 11) until step 7 is completed.

8. At the tail end, note that the accessory cover (aft portion of the tail cover) is held in place by a hoop-like clamp ring similar to that found on a commercial open-top steel or fiber shipping drum. This ring is located about four inches forward of the aft end of the cover, and is fastened at one point by a toggle arrangement. Remove the cotter pin, and pry open the toggle. This will allow removal of the clamp ring.

9. Remove the accessory cover by pulling or driving it aft with a hammer. Use care in removing this cover, so that the fins do not fall to the ground and become damaged. Discard the O-ring gasket.

10. The following parts are stowed in the accessory cover:

Four fins.

Two oval-shaped filling hole covers.

One cloth bag containing twenty-four lockpins, and one grooved fiber block.

Remove these parts by unclamping them, and inspect them for damage. Place the parts on the deck or in the accessory cover for future use. Do not open the bag of lockpins until required for assembly.

11. After removing the accessory cover and accessories, remove the inside tail cover by means of the four lever handles similar to those previously found on the nose cover. Pry up the handles and turn them to release the internal hooks. Discard the tail cover. (Refer to the preceding steps 4 and 5 for details of this procedure.)

12. Reach into the open tail, grasp the aluminum tail cone section, and pull it out. **DO NOT SLAM OR JERK THE SECTION; PULL FIRMLY AND EVENLY.** Continue to pull the tail section until both parts extend to approximately full length. The end of the tail will be about five feet beyond the center section when fully extended. **DO NOT SLAM OR JERK THE SECTIONS; PULL FIRMLY AND EVENLY.** Wiggle the sections from side to side if friction occurs.

Assembly

CAUTION: Igniters, fuzes, and bombs shall not be unpacked in advance of requirements. Once Bomb Mk 79 Mod 0 is assembled, it cannot be disassembled. If fuzes and igniters are unpacked prematurely, return them to their original packings.

1. Place the bomb on a bench, hand truck, dolly, or on the ground, and block it so that it cannot roll. Refer to Unpacking, steps 1 and 2.

2. Locate the white-painted alignment stripe which extends over all the joints on the top of the bomb, near the suspension lugs. Turn the bomb so that this stripe is clearly visible.

3. Pull out the three fore-and-aft sections to full length, so that the white stripe is in line (by eye) at all the joints. **DO NOT SLAM OR JERK THE SECTIONS; PULL FIRMLY AND EVENLY.** Wiggle the sections from side to side if friction occurs. The joint ends of the white alignment stripe should line up within approximately the thickness of a five cent piece when the bomb sections are aligned properly.

4. When the bomb is in alignment, the two fuze wells, the two filling holes, and the suspension lugs should all be in line; the fins should be at 45 degrees with the suspension lugs.

5. Near the end of each section, there are outside slots approximately one inch long by one-quarter inch wide. Although these slots are provided for the lockpins, a screwdriver can be inserted in them to pry or drift the sections, if necessary during alignment.

NOTE: When the sections are properly in line and are out to proper length, there will appear a mating slot in each inner section, underneath the slot on the outside.

6. When the sections are out to length and the slots line up properly, install the lockpins. These pins are in the cloth bag previously removed from the accessory cover. (Refer to the preceding step 10.) There are twenty-four lockpins; only twenty are required to assemble the bomb, four are spares.

7. For easier assembly, drive the lockpins in the sequence outlined in the following step 8. These pins can be driven with any hammer, or even with a stone, in an emergency. They

drive like nails and should drive about as easily as twenty-penny nails in hard wood. It will be helpful, when driving the first few pins in each joint, to use a screwdriver in the lockpin slots to pry or drift the inner and outer slots into line with each other.

CAUTION: If the pins appear to drive too hard, check for misalignment of the sections. Do not force them without first being sure of the alignment; the bomb skin may be damaged by improper driving of the pins.

8. The lockpins may be driven in any sequence. However, it has been found easier in the following sequence:

- a. Drive one pin in each joint, presumably on top near the alignment stripe.
- b. Turn the bomb over and drive a second pin in each joint directly opposite the first pin.
- c. The remaining pins can be driven in any sequence. The pins are self-locking, and should be driven flush with the bomb skin.

CAUTION: DO NOT HAMMER DIRECTLY ON FINS. They are soft aluminum and are easily damaged. A grooved, fiber pounding block is shipped with the bomb. Refer to Unpacking, step 10. Place the groove in the block over the edge of each fin, and hammer on the block.

9. The fins should be placed over the fin stubs on the tail of No. IV section, with the sloping edge forward. Using the fiber pounding block, hammer the fins solidly down and aft, until they bottom. Be sure that the lower edge of each fin enters the fore-and-aft guide clips properly. When each fin is properly in place, bend the longer of the two forward guide clips over the leading edge of the fin, to lock the fin and thus prevent removal or displacement.

10. **Nose and Tail Caps.** Refer to Unpacking, step 6. These caps are not interchangeable; each cap will fit in its correct location only. The caps fit into the open holes at the nose and tail. Line up each cap with its mating hole, and push solidly with the hands until the cap bottoms and the spring pins engage properly. The caps will seem rather loose when properly installed. When necessary, an installed tail cap

can be removed by grasping the cap between the hands, and turning and pulling aft at the same time.

11. Fill bomb through one or both filler holes. Both filler covers must be removed even if filled through one hole only. Detailed instructions for mixing the gasoline gel and filling the bomb will be given in OP 2183 (under preparation).

12. **Filling Hole Covers.** The filling hole covers are oval in shape, one end being smaller than the other. Open the cover by lifting the cam handle. The spring will keep it open. To insert the cover in the bomb, grasp it by the cam handle and insert the small end of the bottom plate **CROSSWISE** in the filling hole. When the bottom plate has entered, turn the cover at right angles so that the small end is aft and the shape of the cover lines up with the shape of the hole. The cover should be very free and loose until the cam handle is pushed down. Push the cam handle down flush. This locks and seals the cover. The cam handle should go down smoothly and easily. If it does not do so, the cover may be fouled on the internal rubber extension sleeve. Shaking the cover in the hole should free it. The cover can be removed by prying up the cam handle with a screwdriver, and reversing the preceding procedure.

13. Install bomb securely on aircraft and sway brace.

14. Remove fuzes and igniters from their packings. Install Fuzes M173 in Igniters M23. Refer to OP 988 (First Revision) for detailed fuzing information.

CAUTION: Do NOT insert the filling hole covers in the bomb until after it is filled with Napalm. If the bomb is stored empty for a period of more than several hours, it is advisable to leave the cam handle open and the cover loose.

15. Remove the igniter well covers. These covers are shipped in place in the wells, and are held in place by three springs, two of which have tabs extending above the cover to facilitate removal. To remove the covers, squeeze the tabs together between the thumb and forefinger until the springs release. The cover then may be lifted out.

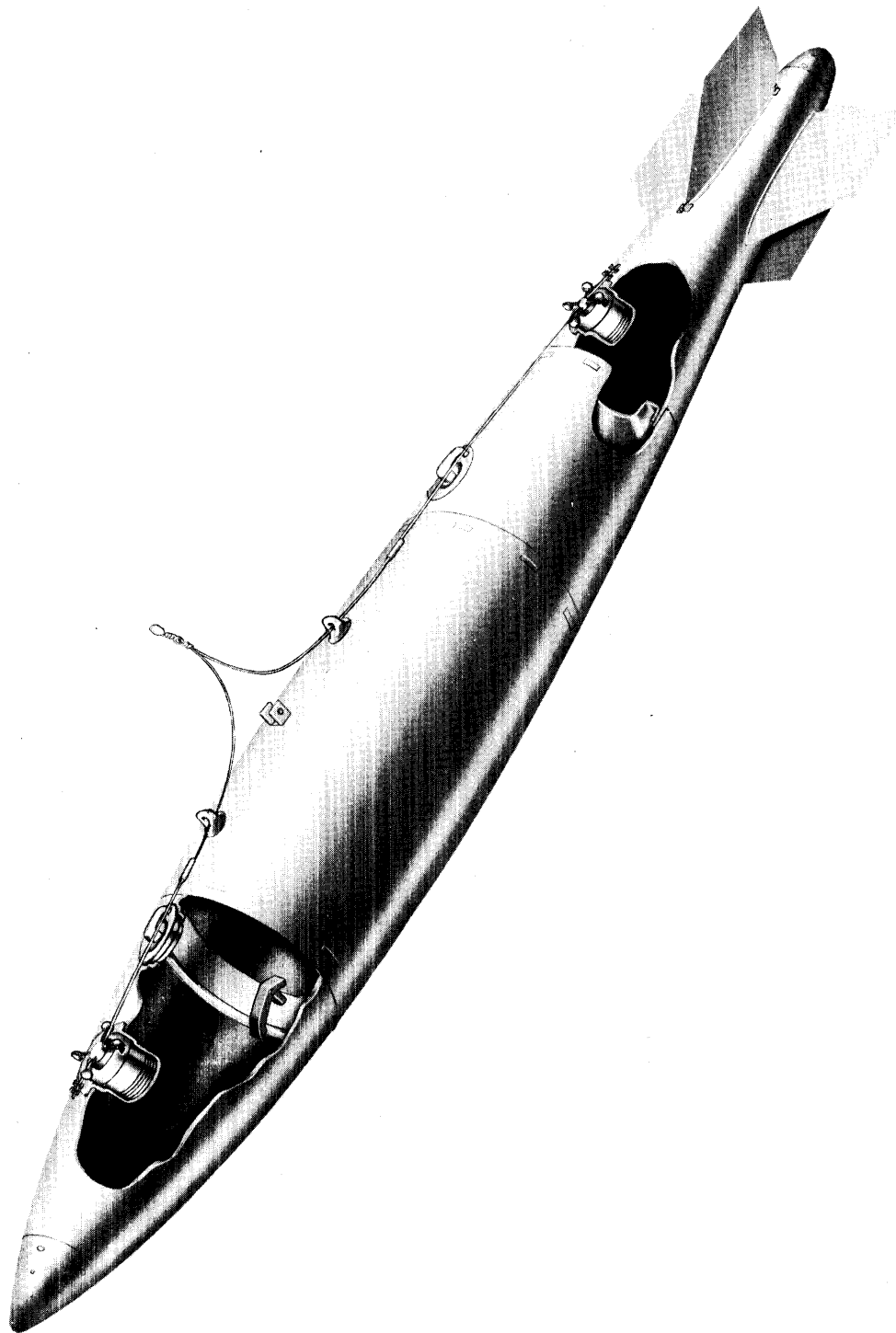

Figure 12.14—1000-lb Fire Bomb Mk 79 Mod 0, Cutaway View.

16. To install the igniter-fuze combinations, place them into the wells, lining up the arming wire holes in the propeller so that they are in line with the lugs. Replace the well cover over each fuze, and push down against the spring until the lockpins snap into place. It should not be necessary to remove the safety pins until

the well covers have been installed. Install the arming wires, passing them through the guides on top of the bomb.

17. Attach two Fahnestock clips to each of the wires.

18. Clip off excess wire. Arming wires must be free from kinks, twists, and burrs.

DISTRIBUTION

SNDL Part 1 (No. 67) and Part 2 (No. 24)

Two copies each unless otherwise indicated:

21; 22; 23, 23A; 24A, 24B, 24F, 24J; 26A, 26D, 26F, 26G, 26K, 26K2, 26U, 26GG; 27A; 28A, 28J; 29G, 29H, 29K, 29K1, 29L (5 copies); 31B, 31C; 32C, 32J, 32BB, 32HH, 32JJ, 32KK; 42A, 42B, 42C, 42D, 42E, 42F, 42I, 42J, 42J1, 42K, 42L, 42M, 42N, 42P, 42S, 42V, 42AA; 45AA; 46A, 46B, 46C, 46D, 46D1, 46G, 46J, 46K, 46L, 46R, 46U, 46V, 46Z; A3(CNO); A5(BUAER, BUSHIPS); A6; B3(War College and Staff College); C1(Aberdeen); C2(Eglin), C4(FC AFSWP Sandia); F1, F2, F3; G1A(5 copies), G1B, G1C, G1D, G1F, G1G, G1H, G2, G3A, G3B, G3C, G3D, G3E, G4B, G5A, G5B, G5C, G5D, G6A, G6B, G7B, G7C, G8V, G8W, G9A, G13, G14, G16, G17, G18; J28, J30, J31, J33, J36, J37, J60, J71, J94, J95, J96, J97; K1, K2A, K2C, K2D, K2E, K3, K5B, K5E, K7, K8, K9, K10, K11, K12, K20; L1; M17, M26, M27, M28, M46; P1, P2; R10, R20, R34.

Requests for additional copies of OP 1280 (First Revision), should be submitted on NAVEXOS 158, Stock Forms and Publications Requisition, to the District Publications and Printing Office by which addressee is serviced.

15 Sept 55/8M/1