

Viruses and Human Cancers: a Long Road of Discovery of Molecular Paradigms

Martyn K. White,^a Joseph S. Pagano,^b Kamel Khalili^a

Department of Neuroscience, Temple University School of Medicine, Philadelphia, Pennsylvania, USA^a; Lineberger Comprehensive Cancer Center, University of North Carolina at Chapel Hill, Chapel Hill, North Carolina, USA^b

| | |
|--|-----|
| SUMMARY | 463 |
| INTRODUCTION | 463 |
| HISTORY OF TUMOR VIROLOGY | 464 |
| THE ISSUE OF ESTABLISHING CAUSALITY | 465 |
| VIRAL MECHANISMS OF TRANSFORMATION AND TUMORIGENICITY | 466 |
| ROLE OF THE IMMUNE SYSTEM: IMMUNITY AND VIRAL MECHANISMS OF IMMUNE EVASION..... | 473 |
| Downregulation of the Major Histocompatibility Complex or Associated Functions | 473 |
| Interfering with Interferon Action | 474 |
| Molecular Mimicry..... | 474 |
| Generation of Escape Mutants | 474 |
| Other Strategies | 475 |
| CONCLUSIONS AND FUTURE DIRECTIONS | 475 |
| ACKNOWLEDGMENTS..... | 476 |
| REFERENCES | 476 |
| AUTHOR BIOS | 480 |

SUMMARY

About a fifth of all human cancers worldwide are caused by infectious agents. In 12% of cancers, seven different viruses have been causally linked to human oncogenesis: Epstein-Barr virus, hepatitis B virus, human papillomavirus, human T-cell lymphotropic virus, hepatitis C virus, Kaposi's sarcoma herpesvirus, and Merkel cell polyomavirus. Here, we review the many molecular mechanisms of oncogenesis that have been discovered over the decades of study of these viruses. We discuss how viruses can act at different stages in the complex multistep process of carcinogenesis. Early events include their involvement in mutagenic events associated with tumor initiation such as viral integration and insertional mutagenesis as well as viral promotion of DNA damage. Also involved in tumor progression is the dysregulation of cellular processes by viral proteins, and we describe how this has been investigated by studies in cell culture and in experimental animals and by molecular cellular approaches. Also important are the molecular mechanisms whereby viruses interact with the immune system and the immune evasion strategies that have evolved.

INTRODUCTION

The history of cancer research is a history of trends, and perhaps no topic exemplifies this more than the role of viruses in the etiology of malignancy (1). As described in more detail in History of Tumor Virology below, it began with the discovery in 1911 of a filterable agent that was able to transmit sarcomas in chickens (2), and later this was shown to be a retrovirus that had transduced a gene, *v-src*, derived from a cellular homolog, illustrating the concept of proto-oncogenes and oncogenes (3). During the 1970s and 1980s, viral transformation of cells in culture by retroviruses such as Rous sarcoma virus (RSV) and specifically of human cells as shown by the small simian DNA tumor virus simian virus 40 (SV40) became widely used as models in cancer research labora-

tories. Such research received less emphasis in the 1990s, especially with the advent of research into the tumor suppressor genes (4). In addition, research into the role of viruses in the etiology of human cancers also became less regarded at that time. Today, there is clear evidence for the involvement of seven different viruses in the etiology of human cancers, and this is the subject of this review.

In the context of human cancer, malignancy is defined as the ability of cells to grow progressively and kill their host (5). For this to happen, it is necessary for a solid tumor to acquire several hallmark biological capabilities during the process of multistep development of the tumor (6). These include a sustained proliferative capacity, the ability to induce new angiogenesis, invasion, and metastasis. To study the molecular and cellular biology of cancer cells, culture systems have been developed to assess growth characteristics important for their malignant character, such as transformation and tumorigenicity. Transformation is manifested by the acquisition of a number of cellular properties that comprise the transformed phenotype. These include the loss of proliferative control, the ability to grow in a substrate-independent fashion (growth in soft agar), failure to show contact inhibition, characteristic alterations in cell morphology, and changes in cell energy metabolism, e.g., increased glucose transport. Tumorigenicity is a measure of the ability of cells to grow progressively and form a tumor after inoculation, usually subcutaneously, into an immunocompromised experimental animal. However, it is important to note that transformation and tumorigenicity are experimental models, and care should be taken when analyzing and interpreting

Address correspondence to Kamel Khalili, kamel.khalili@temple.edu.

Copyright © 2014, American Society for Microbiology. All Rights Reserved.

doi:10.1128/CMR.00124-13

them, especially when using cell lines. For example, the NIH 3T3 fibroblast cell line can begin to exhibit some of the properties of the transformed phenotype if subcultured improperly or to a high passage number (7, 8). Likewise, “untransformed” BALB/3T3 cells are able to form solid tumors if they are inoculated attached to glass beads (9, 10). Nevertheless, transformation in cell culture has been used extensively as a tool to study molecular and cellular mechanisms in the field of cancer research and is often cited as evidence for a role for a particular virus or viral gene in the etiology of cancer. In this review, we consider the evidence for the involvement of viruses in human cancer and the molecular mechanisms involved. It is of note that the many pathways affected by oncoviruses to establish tumors are relevant as “hallmarks of cancer” (6).

HISTORY OF TUMOR VIROLOGY

The notion that viruses have a role in the etiology of malignancy originated from the studies published in 1911 by Peyton Rous, who reported a filterable agent (Rous sarcoma virus [RSV]) in cell extracts of a chicken tumor that could transmit the tumor into healthy chickens (2). The discovery of this retrovirus opened up the field of tumor virology, demonstrating that some cancers could have an infectious etiology and eventually leading to the discovery of oncogenes (11). In the 1930s, two tumor viruses were described in mammals, suggesting the possibility that viruses may play a similar causal role in human cancers (12). Shope papillomavirus was isolated from keratinous carcinomas from the cottontail rabbit (13), and mouse mammary tumor virus (MMTV) is a cancerous agent, or “milk factor,” that is transmitted by mothers to young mice in their milk (14). In the 1950s, mouse leukemia virus (15) and mouse polyomavirus (16) were discovered.

In humans, the first tumor viruses were discovered in the 1960s and 1970s (17, 18). Epstein-Barr virus (EBV) (also called human herpesvirus 4 [HHV-4]) was first observed in cells cultured from Burkitt’s lymphoma by electron microscopy, marking the starting point of human tumor virology (19). In the next several years, it was recognized that EBV is a herpesvirus and that EBV infections are ubiquitous, with more than 90% of people becoming infected by their twenties (20). Immunofluorescence assays showed high-level immune responses to EBV antigens in patients with Burkitt’s lymphoma or nasopharyngeal carcinoma (21), and biopsy specimens of these cancers showed the presence of EBV DNA (22). EBV has a 168- to 184-kbp linear double-stranded DNA genome and contains 85 genes, terminal repeat regions, and an internal repeat region (17, 23). During latency, the genome circularizes to form an episome that is maintained at constant copy number and was the first episome discovered in eukaryotes (with the exception of certain plants) (24). EBV is lymphotropic but can also infect epithelial cells, which are the primary site of replication initially (25, 26). There are two subtypes of this virus, EBV-1 and EBV-2, which differ at the EBNA locus (17).

Hepatitis B was recognized as a serum-borne infectious jaundice in the 1940s, and hepatitis B virus (HBV) was identified in the 1970s (27). HBV, which causes acute and chronic liver infections, liver failure, cirrhosis, and hepatocellular carcinoma (HCC), is a hepadnavirus with a small, circular, partially double-stranded DNA genome (28). Epidemiological studies of HBV infection and HCC in the 1970s associated HBV with the development of HCC, and clear-cut epidemiological evidence of an etiological role was published in 1981 (29). HBV transmission is via blood or other body fluids, such as by close contact, heterosexual sex, contact

with blood as occurs in health care settings, perinatal transmission (a major means in Asia), household contact via saliva, etc. About half of all people who are infected with HBV remain asymptomatic. Perinatal infection is important for HBV but not for HCV (30). The symptoms of hepatitis B appear after an incubation period of about 3 to 4 months, with most patients recovering but ~1% developing fulminant hepatitis B, which can lead to acute liver failure requiring liver transplantation. About 5% develop chronic infections, which can cause chronic active hepatitis and cirrhosis (17). Hepatitis B has its highest prevalence in sub-Saharan Africa and East Asia, where infection is more commonly acquired during childhood and results in 5 to 10% of the adult population being chronically infected, compared to 0.5% in the United States. Infection at the time of birth commonly leads to chronic infection: 80 to 90% of infants who are infected in the first year of life go on to develop chronic infections (common in Asia), and 30 to 50% of children who are infected before the age of 6 years develop chronic infections (common in Africa).

Human papillomaviruses (HPVs) are an established etiological agent of human cancer. A role for HPV in the etiology of cervical carcinoma was first proposed by zur Hausen in the 1970s (31–33). HPV16 and HPV18 were directly detected in cervical carcinoma in the 1980s (34, 35). Epidemiological studies in the 1990s implicated “high-risk” HPV infections in a causal role in cervical carcinoma (17). On a global scale, HPV infections account for more than half of all infection-linked cancers in females, whereas this is barely 5% in males. The HPV genome is a linear double-stranded DNA of 7 to 8 kbp (36) with up to 10 open reading frames (ORFs) and a long control region (LCR) that regulates epithelial cell-specific transcription and is regulated by viral and cellular transcription factors. HPV transmission occurs by mucosal contact and by skin-to-skin contact and is facilitated by microabrasions in the skin or mucosal epidermal surfaces. Anogenital HPV infections usually occur by sexual contact. HPV is the major cause of cervical carcinoma and is also involved in cancers of the anogenital tract, penis, vulva, vagina, anus, oropharynx, and others (17). Most HPV infections in young women are transient, but persistent infection with “high-risk” genotypes may lead to the progression of precancerous lesions and eventually invasive cancer (37). Importantly, this led to the development of the “anticancer” vaccines Cervarix and Gardasil, which protect against infection with HPV16 and HPV18, which are the cause of most cases of cervical cancer. These act in a similar fashion to the HBV vaccine produced earlier in the sense that they prevent infection and thus cancer.

In the 1970s, a peculiar clustering of leukemia cases in southwest Japan (endemic adult T-cell leukemia/lymphoma [ATL]) led to the isolation of a retrovirus from cell lines derived from patients with human adult T-cell leukemia (38), and the sequence of this virus (39) showed it to be identical to human T-cell leukemia virus type 1 (HTLV-1), isolated from a T-cell line, which was discovered earlier by Robert Gallo’s group and was the first known human retrovirus (40). HTLV-1 is most prevalent in southern Japan but is also present elsewhere, e.g., Australia and northern Canada, with an estimated 15 to 20 million people being infected worldwide (41). The virus is transmitted sexually and also parenterally, e.g., by blood transfusions, dirty needles, breastfeeding, etc., and it accounts for 0.03% of all cancer. Latency between infection and ATL onset is decades, and only a small percentage of infections result in ATL (42). While HTLV-1 is found elsewhere in the world, the family clustering of ATL in Japan has a genetic basis, perhaps

involving HLA type (43). The genome of HTLV-1 has a characteristic retroviral organization, i.e., *gag*, *pol*, and *env*, but also a region at the end designated pX, which contains genes that are important for oncogenesis and is discussed below.

In the 1970s, it was recognized that there was a type of hepatitis that was different from hepatitis A and hepatitis B that was spread by transfusions (44). In 1989, Choo and coworkers isolated a cDNA clone from a library made from the plasma of a chimpanzee experimentally infected with non-A non-B hepatitis that encoded an antigen associated with non-A non-B infections and was derived from an $\sim 10^4$ nucleotide positive-strand RNA (45). Infection is often asymptomatic but can lead to liver damage and cirrhosis. Infection is widespread, with 130 to 200 million people infected worldwide (46), and is the foremost reason for liver transplants in the United States and the Western world (47). Eighty-five percent of HCV-infected adults go on to develop chronic infection, which leads to cirrhosis and HCC and is in stark contrast to the case for HBV. HCV is a flavivirus with a 9,600-nucleotide linear uncapped single-stranded RNA genome with a positive polarity and has an uninterrupted ORF encoding a polyprotein which is processed into 10 structural and nonstructural proteins by host cellular and viral proteases (48). Today, HCV is spread mainly by intravenous drug use and sexually; e.g., prison inmates have high rates of positivity (49). The basis of oncogenesis for both HBV and HCV is chronic inflammatory responses.

Finally, technical advances in molecular biology have allowed the discovery of two new human oncoviruses in more recent years. In 1994, Chang et al. (50) used a technique known as representational difference analysis, which is a PCR-based method that allows the identification and characterization of unique DNA sequences in a diseased tissue compared to nondiseased tissue obtained from the same patient, to isolate a unique sequence present in Kaposi's sarcoma. They discovered Kaposi's sarcoma-associated herpesvirus (KSHV), a member of the gammaherpesviruses, which is a subfamily of *Herpesviridae* that is distinguished by a more variable rate of reproduction than in the other subfamilies of *Herpesviridae* and also includes EBV (50). Kaposi's sarcoma is a rare skin tumor that was first described by Moritz Kaposi in 1872 and rose to prominence in the early 1980s as an AIDS-defining disease caused by KSHV, which is also known as human herpesvirus 8 (HHV-8). KSHV is also the causative agent of primary effusion lymphoma (51) and multicentric Castleman's disease (52, 53). The genome of KSHV has a 140.5-kbp coding region with at least 81 ORFs (54). KSHV infects B lymphocytes, endothelial cells, macrophages, and keratinocytes, and the receptor for viral entry is $\alpha 3\beta 1$ integrin (55). After infection, KSHV can circularize and exist in a latent form as an episome expressing viral latency-associated nuclear antigen (LANA), which subsequently can be reactivated and lytically replicate to yield linear DNA molecules for the next round of infection.

The most recent human oncogenic virus to be discovered is Merkel cell polyomavirus (MCV) (56), the only proven oncogenic virus of the many human polyomaviruses (57). The role of animal polyomaviruses in tumorigenesis has long been known, and two human polyomaviruses, JC virus (JCV) and BK virus (BKV), were identified in 1971 (58–60). More recently, at least eight new human polyomaviruses have been discovered (57), and one of these, MCV, was identified in patients with Merkel cell carcinoma (MCC), which is a rare but highly aggressive malignancy. MCC is a neuroectodermal tumor that is may arise from the mechanore-

ceptor Merkel cells of the skin (61). Immunosuppression is a predisposing factor for MCC (62), which raised the possibility that, like Kaposi's sarcoma, MCC may have an infectious origin. A search for viral sequences that might be present in MCC was conducted by Feng et al. (56) using digital transcriptome subtraction, which is a bioinformatics method for detecting novel pathogens by high-throughput sequencing and computational analysis. This led to the discovery of a novel transcript with a sequence that had homology to T antigen (T-Ag) of polyomaviruses. This was designated Merkel cell polyomavirus (MCV), a novel circular DNA virus with a genome size of 5.4 kb, which was found to be clonally integrated into the cell genome in $\sim 80\%$ of cases of MCC (56). Since the integration of viral DNA into the cell genome occurs at a single site, this indicates that the integration event preceded the expansion of the tumor, providing important evidence for the role of MCV in neoplasia. Similarly, a metastatic tumor from the same patient had a pattern of integration identical to that of the primary tumor (56). Subsequent studies of other MCC patients have confirmed that integration of MCV occurs in a large percentage of cases, providing molecular evidence for a causative role of MCV in oncogenesis (63–66). Importantly, the integration event reveals a signature for large-T-antigen disruption in a specific region that prematurely truncates the protein (67). The molecular significance of this is discussed below. Seroepidemiological studies indicate that infection by MCV is widespread in the human population (68–70). The site of replication of MCV may be the Merkel cells of the skin, since it is associated with MCC (61). Studies of MCV replication have proved to be difficult because the virus cannot be cultivated in tissue culture beyond the stage of primary low-level virion production from cells transfected/infected with viral genome (71).

Thus, there are seven currently known human cancer viruses. Below we discuss the status of our understanding of the molecular mechanisms whereby these viruses induce tumors.

THE ISSUE OF ESTABLISHING CAUSALITY

The establishment of a generally held view that a particular virus causes cancer has often been a long, drawn-out process, since the barriers to acceptance are very high and rightly so. The criteria that are usually used to assign causality are the consistency of association at the epidemiological and/or molecular level and the tumorigenicity of the agent in animal models or its transforming ability in cell culture (72). The classic standard for causality in medical research is the application of Koch's postulates (73). Briefly, these are as follows: (i) the microorganism must be found in all cases of the disease but not in healthy individuals unless there can be asymptomatic carriers, (ii) the microorganism must be isolated from the disease and propagated in culture, (iii) the microorganisms from cultures should cause disease when reintroduced, and (iv) the microorganism must be reisolated from the inoculated host with the disease and be identical to the original agent. These postulates are very difficult to apply to human viruses and cancer for a number of reasons, which have been described in a number of recent reviews (17, 74) and will be summarized briefly here.

First, it is often the case that there is a long latency period between primary viral infection and occurrence of the cancer. For example, the latency period between HTLV-1 infection and onset of acute T-cell leukemia is on the order of decades, and only a minor fraction of individuals who are infected will go on develop ATL (42). Similarly, virus infection can often be subclinical, and

so it is difficult to establish the time of infection. For many cancer viruses, infection is widespread but the associated cancer is rare. For example, seroepidemiological studies show that 63 to 75% of the population has been exposed to MCV (70), but the incidence of Merkel cell carcinoma (MCC) is 0.17/100,000 to 0.34/100,000 in the United States (75). Some cancers often require cofactors as well as the virus to develop. For example, in the case of HPV, cofactors in the development of cervical cancer include smoking, hormonal contraceptives, nutrition, and coinfections with other organisms, such as herpesvirus, *Chlamydia*, and HIV (17). In some cancers, the virus may integrate irreversibly into the host genome during pathogenesis (e.g., with MCV [56]), so it is impossible to culture infectious progeny. The outcome of virus infection may vary depending on host factors such as immune status; e.g., the impaired immune system in HIV/AIDS is a major predisposing factor for Kaposi's sarcoma. Viruses may employ different mechanisms in the multistage process of carcinogenesis: HPV promotes chromosomal instability and so may directly contribute to cellular genetic changes (76), whereas the role of HBV and HCV in HCC development is more indirect, involving chronic inflammatory responses and taking many decades while mutations accumulate, often aided by exposure to aflatoxin and alcohol. Finally, for many viruses there is a lack of an animal model, and indeed some, e.g., MCV, lack even a cell culture system. It should also be noted that viruses can cause cancers with histopathological features similar to those of cancers caused by other factors.

In order to address these problems, a number of approaches have been suggested, such as criteria defining environmental causes, consistency, specificity, temporality, plausibility, etc. (77), and epidemiological approaches (78). Guidelines have been proposed for relating a given virus to a human cancer (17). Briefly, these are as follows: (i) the geographical distribution of viral infection should match that of cancer after adjustment for other cofactors, (ii) viral markers (e.g., antiviral antibody titer or presence of virus-specific cytotoxic T cells) should be higher in cases of cancer than in controls, (iii) viral markers being present should precede the tumor and have an incidence that matches the incidence of the tumor, (iv) prevention of viral infection (e.g., by vaccination) should decrease incidence of the tumor, (v) the virus should exhibit transforming properties with human cells in culture, and (vi) the virus should induce tumors in animals and this should be preventable by viral neutralization. Recently, humanized mouse models have been developed to study viral infections, e.g., for HBV and HCV (79) and EBV (80). In practice, these issues can be complex and depend on the virus. For example, there is an increased risk of certain types of noninfectious cancers in HIV-1-infected individuals, presumably due to the defective cell-mediated immunity (81), but HIV-1 is not considered an oncovirus. Clearly, much research into the epidemiology, virology, and molecular biology of a virus is needed before it can be accepted as an oncovirus.

VIRAL MECHANISMS OF TRANSFORMATION AND TUMORIGENICITY

Early studies on the regulation of cell proliferation and discoveries in the field of signal transduction employed the transformation of cultured cells by oncoviruses as model systems. Transformation of human cells by SV40 was first reported in the early 1960s (82). The key cellular tumor suppressor and cell cycle regulator p53 was identified as a cellular protein that bound to large T antigen in an

SV40-transformed mouse cell line (83). Another tumor suppressor and cell cycle regulator, pRb, is the protein product of the retinoblastoma susceptibility gene Rb and was found to be identical to p105, a cellular protein that binds to the E1A transforming proteins of adenovirus, a virus that can immortalize primary cells *in vitro* but is not thought to be associated with human cancer (84). Similarly studies of tyrosine phosphorylation of proteins in Rous sarcoma virus-transformed chicken embryo fibroblasts led to the discovery of pp42 (85), which was later identified as p42/mitogen-activated protein kinase (MAPK) (86), a central signal transduction protein. Investigation of the molecular mechanisms used by the viral transforming proteins, including those of the seven human oncoviruses, is still an active area of research today, (Table 1).

In general, cancer development is a complex multistep process, and this is also true for cancers arising from the effects of viruses, which exert effects on different stages of tumor formation depending on the virus. Viruses can exert their effects on the early stage of oncogenesis involving genetic events that are involved in tumor initiation or, alternatively, act at later stages by modulating signaling pathways involved in the regulation of cell proliferation, apoptosis, replicative immortality, and others, such as tumor promotion.

Several human oncoviruses, including HPV, can cause genetic changes to the host genome that can initiate and contribute to carcinogenesis. In the case of HPV, the viral genome is normally episomal in basal epithelial cells that have become infected by virus but are not producing virus. However, in HPV-transformed cells, i.e., those that are infected and have begun malignant progression, it often becomes integrated into the host DNA by random integration events which leave the E6 and E7 oncogenes (see below) intact and still expressed, underlining their importance in tumorigenesis (87). Integration is not a normal part of the life cycle of HPV, and when it occurs, HPV becomes unable to complete its life cycle. Indeed, there is evidence that both episomal and integrated HPV can be present at the same time during the early phase of tumorigenesis and that episomal HPV become less common at later stages, but there is continued and robust expression of E6 and E7. E6 and E7 are thought to have a role in carcinogenesis for the high-risk HPVs (HPV16, -18, and -31) (17). Cells with integrated HPV proliferate more rapidly and form a pool of immortalized cells where it is possible for further mutations to occur and lead to carcinoma formation. Enhancing this, E6 and E7 cause genetic instability (87), and it has been reported that acquisition of elevated levels of chromosomal instability is associated with the integration of HPV16 in cervical keratinocyte cell lines (88).

An approach that is much used in the study of viral oncoproteins is to express them in cell culture and analyze cellular properties that are altered, e.g., proliferation, ability to grow in soft agar, loss of contact inhibition, cell morphology, and metabolic changes (i.e., the transformed phenotype). Caveats in the interpretation of such experiments are important, as was stressed in the introduction; nevertheless, they may be indicative of the role of a protein in viral carcinogenesis. For HPV16, E6 is a 158-amino-acid protein that is present in both the nucleus and the cytoplasm and will immortalize human cells at low efficiency but will cooperate with E7 to transform primary human keratinocytes (89). E6 alone will transform NIH 3T3 cells, and it cooperates with Ras to transform primary rodent cells (90).

Another approach to the study of human viral oncoproteins is

TABLE 1 Human cancer viruses: transformation and tumorigenicity

| Virus | Abbreviation(s) | Type | Family | Cancer(s) | Tropism(s) | Integration | Infectious virus produced | Oncoproteins | Reference(s) |
|--|-----------------|------|----------------|--|--|-------------------------|---------------------------|--|--------------|
| Human papillomaviruses 16 and 18 | HPV16, HPV18 | DNA | Papillomavirus | Cervical carcinoma, anal carcinoma, penile carcinoma | Keratinocytes | Episomal and integrated | Yes | E6, E7 | 34, 35 |
| Epstein-Barr virus | EBV, HHV-4 | DNA | Herpesvirus | Burkitt's lymphoma, nasopharyngeal carcinoma | B lymphocytes, epithelial cells | Episomal | Yes | EBNA-1, EBNA-2, LMP-1, LMP-2, EBERs, BARTs | 19 |
| Kaposi's sarcoma-associated herpesvirus | KSHV, HHV-8 | DNA | Herpesvirus | Kaposi's sarcoma, primary effusion lymphoma, multicentric Castlemann's disease | B cells, macrophages, keratinocytes, endothelial cells, etc. | Episomal | Yes | LANA, vIL-6, vMIP-1, vFLIP, vBCL-2, v-cyclin-D, vGPCR, vRF-1 | 50 |
| Hepatitis B virus | HBV | DNA | Hepadnavirus | Hepatocellular carcinoma | Liver | Yes | Yes | HBx, HBsAg | 27 |
| Hepatitis C virus | HCV | RNA | Flavivirus | Hepatocellular carcinoma | Liver | No | Yes | Core protein, NS3 | 45 |
| Human adult T-cell leukemia virus type 1 | HTLV-1 | RNA | Retrovirus | T-cell leukemia | T lymphocytes | Yes | Yes | Tax, p12, p30 p8, p13 | 38-40 |
| Merkel cell polyomavirus | MCV, MCPyV | DNA | Polyomavirus | Merkel cell carcinoma | Merkel cells | Yes | No | T antigen, t antigen | 56 |

to use animal model systems. Immunocompromised mice, such as nude mice, can be injected with virus, as either virions or virus-infected cells, or alternatively, transgenic mice that express a viral oncogene in a tissue-specific fashion can be produced. When HPV E6 and E7 from high-risk papillomavirus type 16 were expressed in the skin of transgenic mice, the development of preneoplastic lesions was potentiated, and a higher percentage of these mice went on to develop into locally invasive carcinomas (91). E6 and E7 were expressed at high levels in these tumors compared to the preneoplastic lesions, and the site of expression was the proliferating, poorly differentiated epidermal cells. Thus, the HPV16 E6 and E7 genes contribute to epidermal carcinogenesis in an animal model. Further analysis has shown evidence that E6 and E7 contribute in different ways to carcinogenesis in transgenic mice, with E7 promoting benign tumor formation, E6 accelerating progression of these tumors to malignancy, and E6 and E7 together cooperating in tumor induction (92). In cell culture, E7 has immortalizing potential with NIH 3T3 cells and, in combination with human telomerase reverse transcriptase (hTERT), human primary keratinocytes (93).

The oncogenic properties of the high-risk HPVs (HPV16, -18, and -31) are thought to involve mainly the proteins E6 and E7 (89), (94-97). As shown in Fig. 1, cellular p53 is a target of E6, and E6 binds and degrades p53 through an E3 ubiquitin protein ligase called cellular E6-associated protein (E6-AP), which results in the ubiquitination and degradation of p53 (98). E6 also binds p300/CBP, which is a p53 coactivator, resulting in indirect interference with p53, binds and inactivates p21 and p27, hDlg, MUPP1, and hScrib, and may also affect Notch signaling and activate the hTERT promoter via an E6/Myc/Max complex, bind proapoptotic Bak, and promote phosphorylation of pRb. A detailed review of E6 interactions has been published (99).

The other important protein in HPV carcinogenesis is E7, a phosphoprotein with two zinc fingers that shows some structural and functional similarity to adenovirus E1A and SV40 large T antigen. E7 can self-assemble into spherical oligomers and is phosphorylated by casein kinase II, and this is inhibited by myeloid-related protein 8 (MRP-8) and MRP-14, which are growth inhibitory and complex with pRb, p107, and p130, resulting in phosphorylation and E2F release, which promotes cell cycle progression (100). As shown in Fig. 2, E7 can also bind histone deacetylases (HDACs), the S4 subunit of proteasome, Mi2 β , AP-1, MPP2, TATA-binding protein (TBP), and hTid-1 (17), and, like E6, it induces chromosomal instability and cooperates with E6 in this induction (89). Thus, the high-risk HPVs are powerful human cancer viruses that express oncoproteins that act at multiple stages in tumorigenesis from events involved in tumor initiation to later stages of tumor promotion.

EBV and KSHV are DNA viruses but persist during latency as episomes without integration into host DNA. Episomal EBV, however, expresses EBNA and LMP-1, which may be functional depending on the type of latency involved and whether its oncogenic role is direct or indirect. EBV infects B cells and epithelial cells, resulting in either lytic replication in epithelial cells or entry into a latent state in B cells, where the EBV genome becomes circularized and is present in the nucleus as an episome present in chromatin. Latent episomal virus is maintained at a constant copy number by cellular DNA polymerase and expresses only a portion of the proteins that it encodes (up to 8 of ~100). These proteins may be relevant for events involved in cellular transformation,

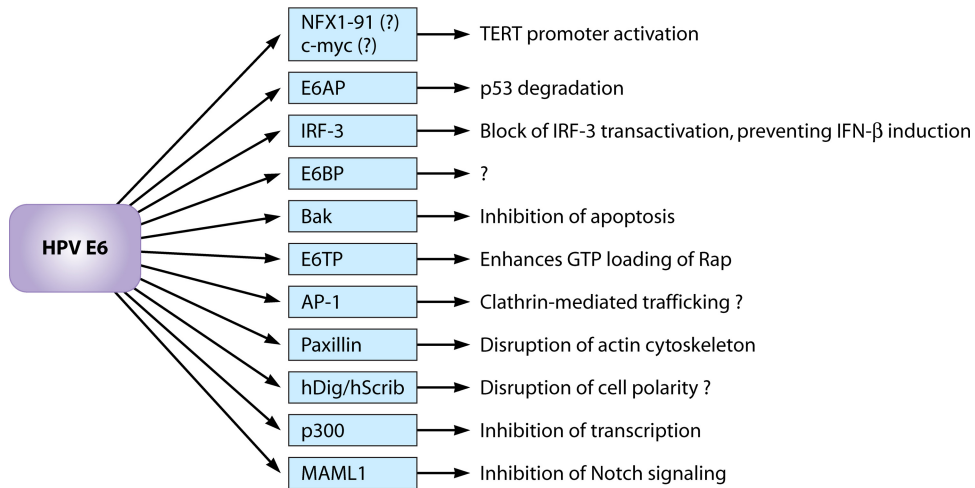

FIG 1 Schematic representation of signaling by high-risk human papillomavirus HPV E6. Targets for HPV E6 (99) (center column) and biological effects (right column) are shown. E6AP, E6AP ubiquitin-protein ligase (UBE3A); IRF-3, interferon-regulatory transcription factor 3; E6BP, E6 binding protein; E6TP, E6-targeted protein 1; AP-1, activator protein 1; Paxillin, human homolog of *Drosophila* disc-large tumor suppressor/human homolog of *Drosophila* Scribble; p300, p300 transcriptional coactivating protein; MAML1, human homolog of *Drosophila* mastermind; TERT, telomerase reverse transcriptase.

most importantly EBV nuclear antigen 1 (EBNA-1) (101), which is a sequence-specific DNA-binding phosphoprotein that is involved in EBV episomal maintenance, DNA replication, and possibly transformation (102). EBNA-1 binds to host DNA and may regulate transcription of cellular genes. Chromatin immunoprecipitation (ChIP) and sequence analysis have identified and defined cellular sites to which EBNA-1 binds (103), although these are not as strong or specific as the binding to viral ori-P. As shown in Fig. 3, EBNA-2 is a nuclear protein and a transcriptional coactivator that induces expression of a number of cellular genes, e.g., EBV receptor/CR2 (CD21) and CD23 antigen (FcεRII), and also transactivates expression of the c-Src family nonreceptor tyrosine kinase member c-Fgr, (feline Gardner-Rasheed sarcoma viral oncogene homolog) (104). EBNA-2 requires a cellular factor to bind its *cis*-responsive DNA element, and this has been identified as RBPJ kappa (105). EBNA-2 can also activate Notch signaling (106) and considerably increases PU.1-dependent upregulation of ubiquitin carboxyl-terminal esterase L1 (UCHL1), which is a multifunctional ubiquitin thiolesterase that is implicated in the pro-

gression of some lymphoid cancers, including EBV-associated lymphomas (107). Expression of the other latency-associated EBV genes, LMP-1 and LMP-2, is also regulated by EBNA-2 (108).

LMP-1 has the ability to induce invasiveness and metastasis factors, e.g., matrix metalloproteinase 9, which disrupts the basement membrane (109). Also, LMP-1 is a viral mimic of a member of the tumor necrosis factor receptor (TNFR) superfamily of proteins that is constitutively active, does not require ligand, and activates the NF-κB, MAPK, phosphatidylinositol 3-kinase (PI3K)/Akt, and JAK/STAT signal transduction pathways, while LMP-2A engages a number of potential signaling pathways such as MAPK, PI3-K/Akt, NK-κB, and STAT (110, 111).

EBNA-2 has a critical role in lymphocyte immortalization, and EBNA-1, EBNA-2, LMP-1, EBV-encoded small RNAs 1 and 2 (EBER1 and EBER2), and the BamHI rightward transcripts (BARTs) act together via multiple molecular mechanisms to effect cellular transformation by EBV in Burkitt's lymphoma and nasopharyngeal carcinoma. Several cellular approaches have been inconclusive about the potential of EBNA-1 to act as an oncogene,

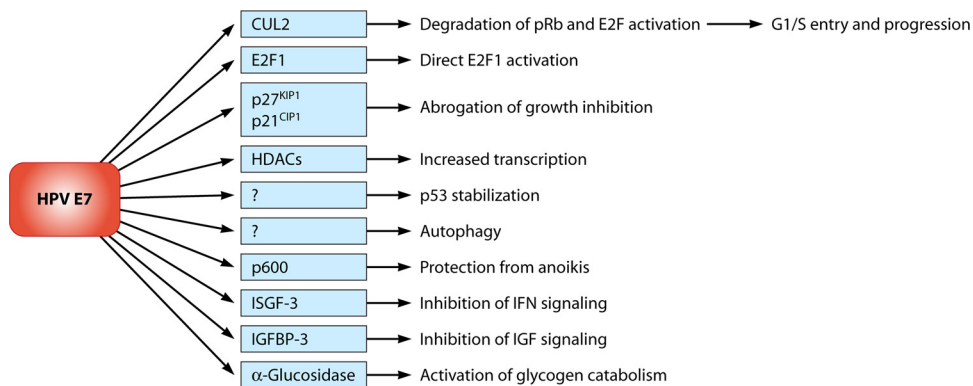

FIG 2 Schematic representation of signaling by high-risk human papillomavirus HPV E7. Targets for HPV E7 (center column) and biological effects (right column) are shown. CUL2, Cullin 2; E2F1, adenovirus E2 promoter binding factor 1; KIP-1, cyclin-dependent kinase (CDK) inhibitor 1B; CIP1, CDK-interacting protein 1; HDACs, histone deacetylases; ISGF-3, interferon-stimulated gene factor 3; IGFBP-3, insulin-like growth factor-binding protein 3.

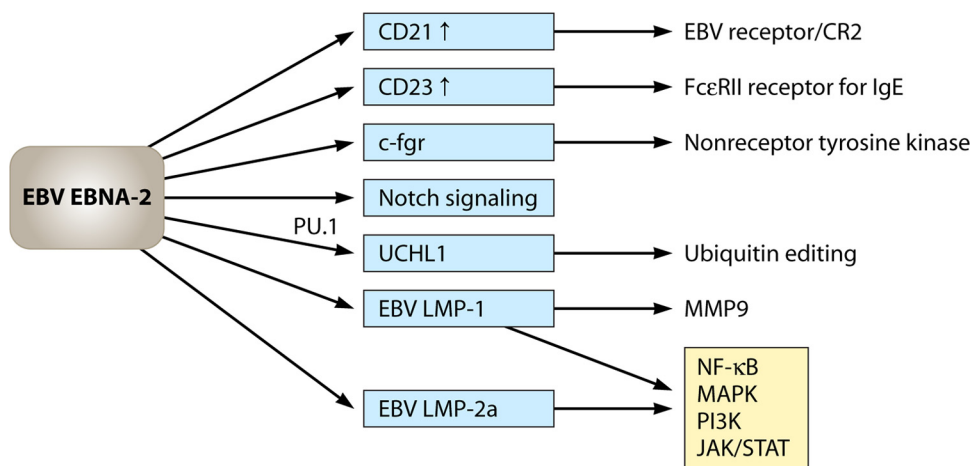

FIG 3 Schematic representation of signaling by EBV EBNA-2. Targets for EBV EBNA-2 (center column) and biological effects (right column) are shown. *c-fgr*, feline Gardner-Rasheed sarcoma viral oncogene homolog; UCHL1, ubiquitin carboxyl-terminal esterase L1 (ubiquitin thiolesterase); MAPK, mitogen-activated protein kinase; PI3K, phosphatidylinositol 3-kinase; JAK/STAT, Janus kinase/signal transducer and activator of transcription.

but in cultures of Burkitt's lymphoma cell lines, increases in expression of the Nox2 catalytic subunit of the NADPH oxidase, levels of reactive oxygen species (ROS), and genomic instability have been reported upon constitutive or conditional expression of EBNA-1. Similarly, in CNE2 cells, expression of EBNA-1 increased Nox2 expression and levels of ROS, which paralleled increased telomere instability. Thus, it has been suggested that EBNA-1 may act as an oncoprotein by contributing to oxidative stress and genomic instability (103). EBNA-2 is a nuclear protein that has a critical role in lymphocyte immortalization. Thus, the P3HRI variant of EBV has a deletion encompassing EBNA-2, is nonimmortalizing, and fails to induce these types of changes in cellular gene expression (112). Another EBV protein, LMP-1, is a principal oncoprotein and has transforming properties in Rat-1 fibroblasts as assayed by loss of contact inhibition (113). EBERS, which are the most abundant EBV transcripts in latently infected cells but are untranslated, confer the ability to grow in soft agar, form tumors in nude mice, resist alpha interferon (IFN- α)-induced apoptosis, and induce the autocrine expression of interleukin-10 (IL-10), which acts as an autocrine growth factor (114, 115). EBV BARTs and EBV-encoded microRNAs are also potentially significant with respect to cellular transformation (116). Similarly, KSHV gene products show oncogenic properties, as discussed below (117). There are conflicting reports on the ability of B-cell-directed expression of EBV EBNA-1 to induce B-cell lymphoma in transgenic mice, with reports of tumor induction (118) and cooperativity with *Myc* in lymphomagenesis (119). In another study, lymphoma was not observed, but the EBNA-1 mice exhibited pulmonary adenomas (120). This may be due to the different genetic backgrounds of the mice used in these studies. Expression of the Epstein-Barr virus LMP-1 has also been reported to induce B-cell lymphoma in transgenic mice (121). As noted above, expression of the EBV EBNA-1 and EBNA-2 transcripts confers clonability in soft agarose and tumorigenicity in immunodeficient mice.

Like EBV, KSHV is a DNA virus of the gammaherpesvirus family and has a large DNA genome. Remarkably, KSHV has an extraordinary array of proteins that mediate transformation. KSHV has appropriated a number of genes that mimic human

cytokines and cytokine response signaling pathway proteins, e.g., vIL-6, vMIP-I, vFLIP, vBCL-2, v-cyclin-D, vGPCR, and vIRF-1, indicating a novel strategy of molecular mimicry to overcome tumor suppressor pathways and drive neoplasia (122). Latent episomal KSHV expresses a protein known as latency-associated nuclear antigen (LANA), a 222- to 232-kDa nuclear protein which tethers the viral episomal DNA to the cellular chromosomes via histone H1 binding. LANA is the main KSHV latent protein expressed in all types of KSHV-associated malignancies and is a key player in viral oncogenesis (123). LANA is a transcriptional regulator which suppresses KSHV replication and transcriptional activator (Rta) expression, thus inhibiting viral lytic replication and maintaining latency (123). As shown in Fig. 4, LANA is highly multifunctional in its transforming actions, interacts with many other cellular proteins, and is involved in the disruption of a number of cellular proliferation control mechanisms: it binds to glycogen synthase kinase 3 β (GSK-3 β), which is a signaling protein in the Wnt pathway and negatively regulates β -catenin, and thereby increase levels of β -catenin and the activity of the downstream transcription factor TCF/LEF (124). Other targets include p53, which is bound and inactivated by LANA (125), and hypo-

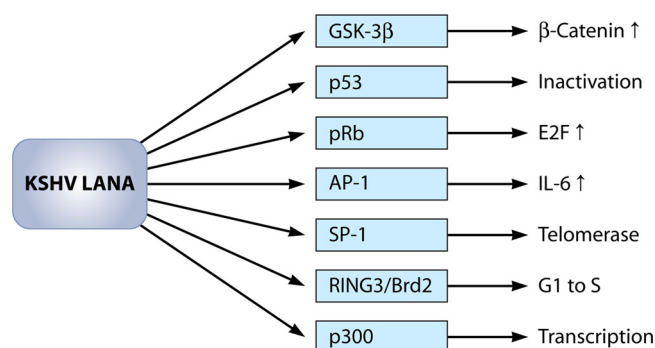

FIG 4 Schematic representation of signaling by KSHV LANA. Targets for KSHV LANA (latency-associated nuclear antigen) (center column) and biological effects (right column) are shown. GSK-3, glycogen synthase kinase 3 β ; pRb, retinoblastoma protein; Brd2, bromodomain containing 2.

phosphorylated (active) pRb, which results in the transactivation of E2F-responsive promoters (117). Additional targets have also been reported, including AP-1, which is activated and thus induces IL-6 expression, Id-1, Sp1 to induce the telomerase promoter, RING3/Brd2, myeloid cell nuclear differentiation antigen (MND1), p300, and p300 (123).

While LANA is the chief player in KSHV latency and oncogenesis, other proteins have roles, including the following: v-cyclin D (ORF72), which is always expressed in Kaposi's sarcoma and primary effusion lymphoma, complexes with Cdk9, and causes phosphorylation of histone H1 and pRb, promoting the G₁-to-S transition; vGPCR (ORF74), which activates phosphoinositide signaling, transforms NIH 3T3 fibroblasts, and upregulates cytokine production by activating NF- κ B, AP-1, and NFATs via Rac1/Pak1; and vFLIP (vFLICE-inhibitory protein, ORF71), which binds to FLICE (Fas-associated death domain protein and caspase 8) and acts as a dominant negative inhibitor of Fas-receptor-mediated apoptosis. Other KSHV proteins involved in transformation include latency-associated membrane protein (LAMP) (K1, ORF75), which has sequence similarity to EBV LMP-1 and activates Ras/MAPK and NF- κ B, and viral interferon-regulatory factor 3 (vIRF-3), which inhibits the transactivation of p53, protein kinase R (PKR)-activated apoptosis, and caspase 3 activation (17, 126). Thus, KSHV has evolved a complex and sophisticated molecular strategy to effect latency and manipulate cellular signal transduction processes, and these disruptions are involved in oncogenesis. Primary rat cells transformed by expression of KSHV LANA in combination with Ha-Ras are them tumorigenic in nude mice (117). KSHV kaposin (K12)-transformed Rat-3 fibroblasts are also tumorigenic in nude mice (127).

Unlike EBV and KSHV, for HBV, the DNA genome is small and encodes only a few proteins. HBx exerts multiple pleiotropic effects, but its functions remain not well understood. HBx and hepatitis B surface antigen (HBsAg) are important in transformation. Integration of the HBV genome into the host genome can occur, but this takes place at no unique site in the cell genome but rather can occur in many different places, and this can be an important mechanism in the development of HCC in HBV-infected individuals, where integration causes disruption of key genes that regulate proliferative signaling. Recurrent preferential integration sites include CCNE1 (cyclin E1, which regulates the G₁/S transition), FN1 (fibronectin), MLL4 (a histone methyltransferase), ROCK1 (a kinase that regulates actin polymerization), SENP5 (a protease for sumoylated proteins), and TERT (telomerase), which regulates cell senescence, as was reviewed recently by Xu et al. and Guerrieri et al. (128, 129). Other mechanisms for tumorigenesis have also been described for HBV, which has a small genome (~3,200 bp) and encodes only four proteins: core antigen (HBcAg), which is a 183- to 185-amino-acid protein that can be phosphorylated and which also has an extracellular variant (HBeAg); DNA polymerase, which is 90 kDa and also has reverse transcriptase activity; HBsAg, which is the surface antigen; and HBx (the functions of these proteins are discussed below). However, it should be noted that HBV carcinogenesis is generally thought to be indirect, it takes around 50 years for gene mutations to accumulate (with inflammatory responses also being important), and it is rare that a direct effect of insertional mutagenesis is seen. Unlike HBV, HCV is an RNA virus, and there is no possibility for it to integrate its genetic material into the host genome (130).

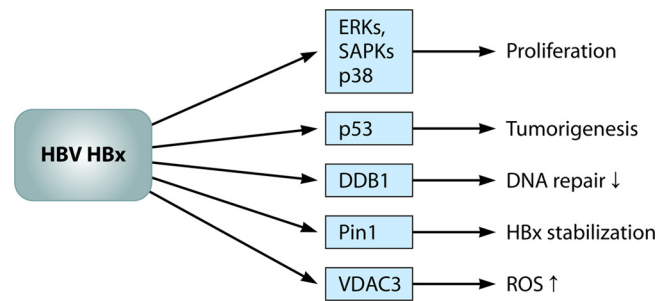

FIG 5 Schematic representation of signaling by HBV HBx. Targets for HBV HBx (center column) and biological effects (right column) are shown. ERKS, extracellular signal-regulated kinases; SAPK, stress-activated protein kinase; DDB1, damage-specific DNA-binding protein 1; Pin1, peptidylprolyl *cis/trans* isomerase; VDAC3, voltage-dependent anion channel 3.

The HBV HBx protein is oncogenic in experimental hepatocellular carcinogenesis, since it is able to transform rodent hepatocytes *in vitro*. HBx sequences persist in clonally expanding rodent hepatocytes, and HBx transforms NIH 3T3 cells in cooperation with Ras (131). Expression of the HBV protein HBx in transgenic mice makes them susceptible to chemical carcinogens, and high levels of HBx expression can lead to HCC (132). HBx acts as an oncogene in experimental HCC and accelerates HCC development in the presence of Myc in transgenic mice without cirrhosis and also augments their susceptibility to develop HCC after exposure to diethylnitrosamine (a strong carcinogen). Further, lowering the levels of HBx mRNA and protein by RNA interference results in a reduction in the tumorigenicity of HCC cells that constitutively express HBx (131). For HCV, in transgenic mice expressing HCV core protein, hepatic steatosis develops early in life and can go on to give liver adenomas and HCC (133). The 5' half of the cDNA for HCV nonstructural protein 3 (NS3) can transform cells in culture and confer tumorigenicity in nude mice for NIH 3T3 cells (134), rat fibroblasts (135), and the QSG7701 human liver cell line (136). HBsAg expression in transgenic mice has also been reported to lead to HCC (137). HCV core protein transforms NIH 3T3 cells via STAT3 activation (138). The function of HBx is not yet well understood, but it may play a part in promoting viral transcription. HBx antigen is present mainly in the cytoplasm but also in the nucleus and, as shown in Fig. 5, activates the extracellular signal-regulated kinase (ERKs), stress-activated protein kinases (SAPKs), and p38 protein kinase pathways (139). It has also been reported to bind to p53 (140).

HCV has a 9,600-nucleotide RNA genome encoding 10 proteins. The mechanisms of HCV carcinogenesis are imperfectly understood, but core protein and NS3 are thought to be important. HCV core protein is able to interact with numerous transcription factors, either directly or indirectly, including hnRNPK, LZIP, RNA helicase CAP-Rf, p53, p21, DDX3 protein, NF- κ B, and 14-3-3 protein, as shown in Fig. 6. HCV core protein may be involved in activation of the Ras/Raf/MAPK pathway, since 14-3-3 protein associates with components of the Raf-1 kinase cascade. Constitutive expression of HCV core protein leads to elevated basal activity of MAPK kinase, as indicated by levels of phosphorylation of ERK-1 and ERK-2. HCV core protein also suppresses the activity of the promoter for the cyclin-dependent inhibitor p21, which is involved in cell cycle control and tumorigenesis. The Wnt/ β -catenin pathway is also involved in HCC carcinogenesis, and tran-

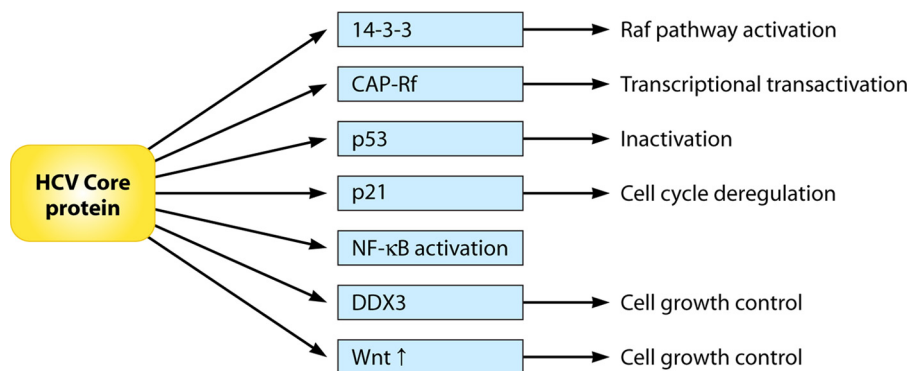

FIG 6 Schematic representation of signaling by HCV core protein. Targets of HCV core protein (center column) and biological effects (right column) are shown. CAP-Rf, RNA helicase; DDX3, DEAD3; ↑, upregulation.

scriptional upregulation of Wnt-1 and its target WISP-2 by core protein suggests that a mechanism involving Wnt signaling may promote cell growth. Regulation of these pathways has been reviewed recently (141). Another HCV protein, NS3, has been reported to bind to p53 (142).

HTLV-1 is an RNA virus and belongs to the retrovirus family, with a genome size of 8.51 kb. HTLV-1 is the causative agent of ATL and can also cause HTLV-1-associated myelopathy/tropical spastic paraparesis (HAM/TSP), which is a rare disease that is thought to result from immunological aspects of host-virus interactions (143). The oncogenic functions of HTLV-1 reside in the pX region of the genome, which encodes the proteins Tax, Rex, and others. Both Tax and Rex, which is an RNA-binding protein involved in splicing and transport of viral mRNA, are required for viral replication, but Tax also stimulates cell proliferation and is thought to be the major transforming protein of HTLV-1 (144). Transgenic mice expressing the HTLV-1 Tax protein under the control of the HTLV-1 long terminal repeat (LTR) developed soft

tissue tumors at multiple sites, showing that Tax efficiently induces mesenchymal tumors in this animal model (145). Well-characterized posttranslational modifications of Tax are acetylation, phosphorylation, ubiquitination, and sumoylation (144). Tax does not bind directly to DNA but instead binds and modulates the activity of transcription factors; e.g., it binds to CREB at the HTLV-1 LTR to stimulate viral transcription (146), as shown in Fig. 7. The CREB/Tax complex is able to recruit the transcriptional coactivators/acetyltransferase p300, and histone acetylation and consequent chromatin remodeling are crucial for the transcriptional transactivation functions of Tax. Also of importance is the activation of NF- κ B, which occurs via both canonical and noncanonical pathways and is essential for Tax-mediated transformation and leukemogenesis (144). A plethora of other activities that are involved in transformation are mediated by Tax, and these are still not fully elucidated but include acceleration of the G₁ phase of the cell cycle, activation of cyclin E and Cdk2, binding and stabilization of cyclins D3 and D2 and cyclin D/Cdk4 com-

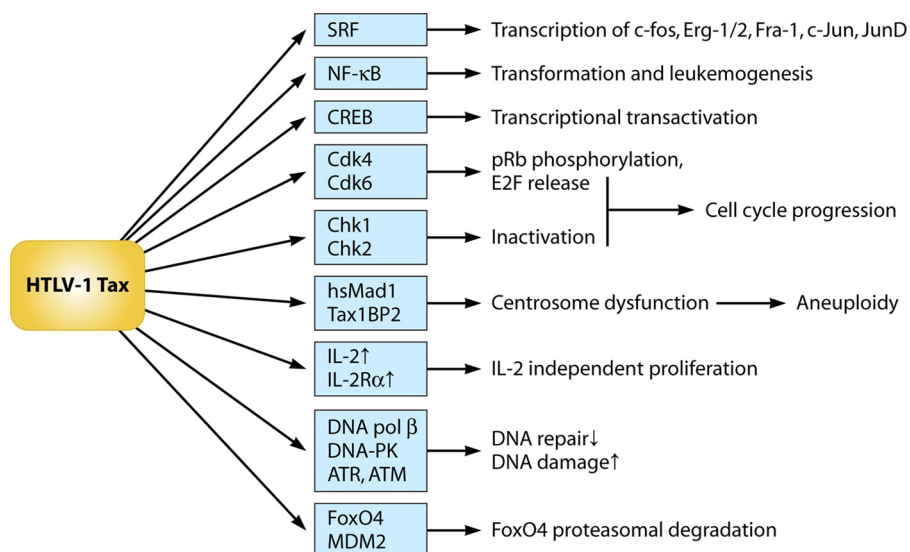

FIG 7 Schematic representation of signaling by HTLV-1 Tax. Targets for HTLV-1 Tax (center column) and biological effects (right column) are shown. ↑, upregulation; ↓, downregulation; SRF, serum response factor; NF- κ B, nuclear factor κ B; CREB, cyclic AMP (cAMP) response element-binding protein; Cdk4, cyclin-dependent kinase 4; Cdk6, cyclin-dependent kinase 6; Chk1, checkpoint kinase 1; Chk2, checkpoint kinase 2; DNA pol β , DNA polymerase β ; DNA-PK, DNA-dependent protein kinase; ATR, ataxia telangiectasia and Rad3 related; ATM, ataxia telangiectasia mutated; FoxO4, forkhead transcription factor FoxO4; MDM2, mouse double minute 2 homolog.

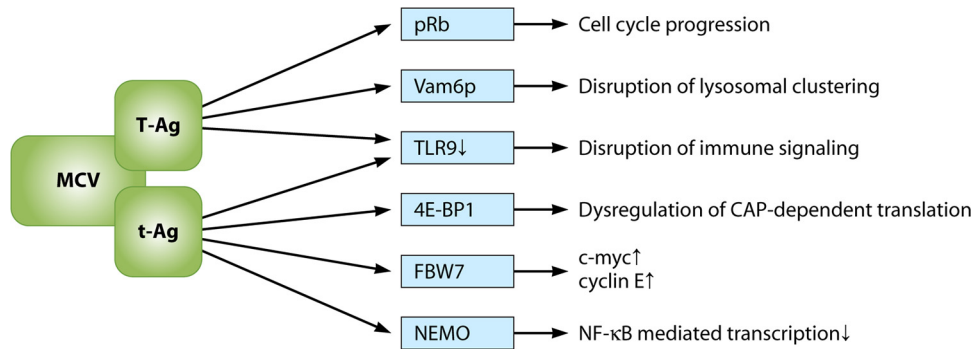

FIG 8 Schematic representation of signaling by MCV large T antigen (T-Ag) and small t antigen (t-Ag). Targets for MCV T-Ag and t-Ag (center column) and biological effects (right column) are shown. ↑, upregulation; ↓, downregulation. pRb, retinoblastoma protein; Vam6p, vacuolar protein-sorting gene product; TLR9, Toll-like receptor 9; 4E-BP1, eukaryotic translation initiation factor 4E-binding protein 1; FBW7, F-box/WD repeat-containing protein 7; NEMO, NF-κB essential modulator.

plexes, promotion of pRb phosphorylation and consequent E2F release, binding of hypophosphorylated pRb and thereby promoting its degradation, activation of telomerase hTERT expression, and inhibition of cellular DNA repair at several levels (144). Tax also causes changes in the intracellular redox status, which promote DNA damage that may also be important in initiating the genetic changes in HTLV-1-infected T cells that eventually promote neoplasia (147). It is thus clear that Tax is a prime example of how a viral accessory protein can be highly multifunctional. HTLV-1 can integrate into the DNA of the host in ATL, and the clonal nature of these integration sites indicates that the integration preceded expansion of the leukemic cells and is thus evidence for insertional mutagenesis by HTLV-1 (148).

In addition to Tax, there are other accomplices in pathogenesis that are expressed from the pX region, namely, p12, p8, p30, and p13 (149). Expression of Tax may be sufficient for the immortalization of human T lymphocytes *in vitro*. In one study, herpesvirus saimiri recombinant viruses expressing Tax were found to be able to immortalize cultured primary human CD4⁺ cord blood lymphocytes. However, in another study with primary human T cells, Tax was found to have weak oncogenic activity. Although Tax expression was necessary for growth of the primary T cells, addition of IL-2 was also required to drive the T cells into cell cycle progression (147). These findings suggest that Tax activity alone is not enough to cause immortalization and that other HTLV-1 proteins are involved in transformation and leukemogenesis. In this regard, p30II has been found to promote cell survival against genotoxic insults in HTLV-1-infected lymphocytes, and so it is possible that, in addition to Tax, the additional activities of other HTLV-1 proteins, such as p12, p8, p30, and p13, are important for transformation (149). p12 has the ability to activate this the JAK/STAT pathway, which signals the effect of the cytokine IL-2 T-lymphocyte proliferation. Thus, expression of p12 results in an increase in STAT5 phosphorylation, DNA binding, and transcriptional activation, which decreases the IL-2 requirement for cell proliferation (150). Microarray analyses indicate that expression of p30 can modulate the levels of proteins involved in apoptosis and the cell cycle, but the biological significance of this is not established (149). However, it has also been reported that p30 promotes the transforming ability of c-Myc (151). The protein p8 appears to function in viral infectivity, while p13 appears to be proapoptotic in some circumstances and its functions in viral persistence are not understood (149).

MCV was first identified as a polyomavirus found to be clonally integrated into the genome of most cases of MCC (56), and it is the most recently discovered human oncovirus. As is the case with the other human polyomaviruses (57), MCV is very common and yet MCC is very rare, which is presumably because integration is not part of the MCV life cycle and is an unlikely event. There is strong evidence that this integration event is involved in the initiation of the tumor, since MCV DNA was found to be clonally integrated into a single site, indicating that the integration event preceded tumor expansion. Moreover, a metastasis from the same patient had an integration pattern identical to that of the primary tumor (56). Integration of MCV has been confirmed in a large percentage of other MCC cases by subsequent studies, providing powerful evidence for a causative role of MCV in integration in MCC oncogenesis (63–66). Also of note, integration always occurs in such a way as to disrupt the MCV large T antigen at a specific region, prematurely truncating the protein in a way that prevents its function in viral DNA replication but retaining its transforming activity (67). The mechanism of polyomaviral transformation, i.e., large T- and small t-antigen function, has been studied for many decades, starting with the discovery of SV40 in 1960, so this has provided a strong basis for studying MCV transformation. Coimmunoprecipitation experiments showed that MCV large T antigen was bound to pRb in all the Merkel's carcinoma samples examined by Shuda et al. (67). In the case of transformation by polyomaviruses such as SV40, JCV, and BKV, many oncogenic protein-protein interactions between large T antigen and cellular proteins, including p53, pRb, IRS-1, β-catenin, and others, and between small t antigen and protein phosphatase 2A (PP2A) have been described, as we have previously reviewed (58–60). In the case of MCV, some of these interactions are conserved, as in the case of pRb binding to large T antigen (152, 153) and its involvement in transformation. On the other hand, an intact p53-binding site in MCV large T antigen is not required, suggesting that transformation by MCV is p53 independent (67). However, MCV proteins can have novel interactions with cellular proteins (Fig. 8) that have not been reported for SV40 or JCV, such as that between large T antigen and the lysosomal sorting protein binding to Vam6p (154). Other examples are binding of MCV small t antigen to the translation initiation factor 4E-binding protein 1 (4E-BP1), causing hyperphosphorylation, which results in dysregulated cap-dependent translation (155), and to E3 ubiquitin ligase Fbw7 (156) (Fig. 8). Investigating the mechanisms of MCV

TABLE 2 Human cancer viruses: mechanisms of immune evasion

| Virus | Abbreviation(s) | MHC regulation | Interferon pathway change(s) | Molecular mimicry | Escape mutants | Reference(s) |
|---|-----------------|---|---|--|----------------|-----------------------|
| Human papillomaviruses 16 and 18 | HPV16, HPV18 | LMP2 and LMP7 ↓, TAP1 and TAP2 ↓, MHC-I ↓ | TLR9 ↓ | | | 161, 168 |
| Epstein-Barr virus | EBV, HHV-4 | TAP ↓ by BNLF2a, MHC-I ↓ by BNLF5, TAP1 ↓ by vIL-10, MHC-I ↓ by BILF1, MHC-II ↓ by gp42/gH/gL, BGLF5, and vIL-10 | Tyk2 ↓ by LMP-1, TLR9 ↓ by LMP-1 | | | 157-159, 164, 169 |
| Kaposi's sarcoma-associated herpesvirus | KSHV, HHV-8 | MHC-I ↓ by MIR1 and MIR2 | IFN signaling ↓ by RIF | v-CCL-1, v-CCL-2, v-CCL-3, v-FLICE | | 174, 175, 178 |
| Hepatitis B virus | HBV | MHC-I ↓ | IFN-α and IFN-β ↓ | Env mimics IgA | Yes | 160, 167, 179, 182 |
| Hepatitis C virus | HCV | | RIG-1 ↓ by NS3/4A, TRIF ↓ by NS3/4A, IL-8 ↑ by NS5A | | Yes | 172, 173 |
| Human adult T-cell leukemia virus | HTLV-1 | | TLR4 signaling ↓ by p30 | | | 149 |
| Merkel cell polyomavirus | MCV, MCPyV | | TLR9 ↓ by T-Ag | | | 170 |

transformation is a new and active area of research that is still revealing novel aspects of MCV T- and t-antigen transformation.

ROLE OF THE IMMUNE SYSTEM: IMMUNITY AND VIRAL MECHANISMS OF IMMUNE EVASION

The human body has elaborated a complex variety of immune defense mechanisms that prevent viral infections and eliminate virally infected cells. In turn, viruses have adapted by evolving different strategies for evading immune responses. In general, it can be said that these mechanisms are also involved in the immune evasion of virally induced cancers and that this is not because the virus evolved to cause cancer but rather is a secondary result of the mechanisms that the virus deployed to evade the elimination of virally infected cells. Indeed, this is similar to the uncontrolled growth of virally induced tumors, which is a secondary result of the mechanisms that the virus evolved to enhance cell proliferation in order to enhance viral replication or perpetuate persistence of the viral genome. The interplay between virus and immune system is apparent from the observation that virally induced cancers, e.g., Kaposi's sarcoma, Merkel cell carcinoma, and EBV-associated lymphomas, are more frequent in individuals with an impaired immune status. In this section, we examine mechanisms involved in interactions between human cancer viruses and the immune system (Table 2).

Downregulation of the Major Histocompatibility Complex or Associated Functions

A major mechanism mediating antiviral action by the immune system is major histocompatibility complex (MHC) presentation of viral epitopes to cytotoxic CD8⁺ T cells. Cells normally present cytosolic peptides products from protein turnover on MHC class I molecules at the cell surface. During viral infection, proteins degraded in the proteasome to cytosolic peptides are brought into the endoplasmic reticulum by TAP (transporter associated with antigen processing), where they bind to nascent MHC class I molecules, followed by display on the cell surface. Consequently,

many human oncoviruses have evolved mechanisms to subvert this process. EBV enters a state of latency in B lymphocytes following primary infection, characterized by EBNA-1 expression, which is involved in maintenance of the viral DNA episome. The ability of latently EBV-infected cells to evade the immune system is conferred by the glycine-alanine repeat domain of EBNA-1, which inhibits MHC class I-restricted presentation of EBNA-1 epitopes linked in *cis* (157). When EBV enters the replicative phase of infection, over 80 EBV genes become expressed, which induce strong immune responses from CD4⁺ and CD8⁺ T cells, but virus successfully replicates. Many studies have provided evidence that this is due to the activities of several viral proteins interfering with the different stages of the MHC class I and class II antigen presentation. These include the following: inhibition of the TAP by BNLF2a, which prevents peptide loading by MHC class I; blockage of MHC class I molecule synthesis by BGLF5; a reduction in the levels of mRNAs for TAP1 and the immunoproteasome subunit bli/LMP2 by vIL-10; inhibition of MHC class I presentation at the cell by BILF1; and inhibition of MHC class II molecules antigen presentation by gp42/gH/gL, BGLF5, and vIL-10 (157–159). By these mechanisms, the EBV lytic proteins effectively interfere with CD8⁺ and CD4⁺ immune responses, allowing viral replication.

Downregulation of MHC expression is also a mechanism employed by HBV. In a study of MHC class I molecules on hepatoplastoma cell lines, the expression of MHC class I molecules HLA-ABC, HLA-E, and MICA was found to be downregulated by HBV (160). Perturbation of antigen processing and presentation is also a key strategy of HPV. Mechanisms of disruption of antigen processing and presentation mediated by HPV include decreased expression of the LMP2 and LMP7 proteasome subunits, decreased expression of the TAP1 and TAP2 peptide transporter subunits, and decreased expression of MHC-I itself (161). The E7 protein of high-risk HPV represses the MHC class I heavy-chain gene promoter and also the bidirectional promoter that regulates expression of both LMP2 and TAP1 (162). HPV E5 downregulates MHC

class I cell surface expression (163). The functional effect of MHC downregulation on the cell surface of HPV-infected cells is a reduced recognition by T cells, leading to an escape from immunosurveillance. Similarly, HTLV-1 interferes with host immune response through the action of p12, which downregulates cell surface MHC-I expression by specifically binding to newly synthesized MHC-I as well as reducing expression of ICAM-1 and ICAM-2 (149).

Interfering with Interferon Action

Interferons (IFNs) are cytokines produced and secreted by host cells in response to foreign pathogens such as viruses, and they function to communicate between cells to trigger protective immune defenses. IFNs were named because of their ability to interfere with the process of replication of various viruses within the host cell. Viral infection causes release of IFN, and neighboring cells respond to it by producing protein kinase R (PKR), which phosphorylates and inactivates eIF-2 and reduces protein synthesis within the cell. Also induced following PKR activation is RNase L, which destroys RNA to further reduce synthesis of both viral and host proteins. Induction of type I IFN production is regulated mainly at the transcriptional level by transcription factors called the interferon-regulatory factors (IRFs), which are controlled by signaling pathways involving the Toll-like receptors (TLRs). Many oncoviruses have adapted mechanisms to escape the effects of interferon. For example, the EBV protein LMP-1 binds Tyk2, a signaling protein in the IFN- α signaling pathway, and prevents Tyk2 phosphorylation, which inhibits IFN- α -stimulated nuclear translocation of STAT2 and thus transcriptional activation of interferon-stimulated response elements (164). IRF-7, discovered in 1977 binding to the EBV Q promoter (165), is considered the “master regulator” of type I interferons. IRF-7 is both induced and activated by LMP-1 (166).

HTLV-1 p30 inhibits TLR4 signaling in macrophages (149). HBV elicits a response from the host innate immune system which is type I interferon dependent, and the virus has evolved a number of mechanisms to suppress these, including inhibition of IFN- α and IFN- β production and inhibition of type I interferon signal transduction pathways (167). To evade the innate immune response, the E6 and E7 proteins of high-risk HPV subtypes such as HPV16 inhibit TLR9 transcription, resulting in functional loss of TLR9-regulated pathways (168), as does EBV LMP-1 (169) and MCV large T antigen (170). E6 protein can inhibit IRF-3 transactivation, preventing IFN- β induction (171). HCV activates signaling by the Toll-like receptors to activate the signal transduction pathways involving NF- κ B and IRF-3, which activates transcription from the IFN- β promoter and also induces IFN- α . The expression of IFN- β -induced genes interferes with HCV translation and replication (172). HCV employs a number of strategies to evade interferon action. HCV NS3/4A protease counteracts IRF-3 activation by blocking signaling by the RIG-1 RNA helicase and cleaving the TLR3 adaptor protein TRIF, while HCV NS5A antagonizes IFN- α function by inducing IL-8, which interferes with interferon action, and HCV NS5A and E2 inhibit PKR (173).

KSHV expresses proteins that subvert the intracellular pathways of type I interferon-mediated antiviral immunity by antagonizing them with effects that are wielded at various stages of the viral life cycle, including KSHV RIF, which binds to several critical components of the type I IFN signaling pathway such as the IFNAR1/IFNAR2 subunits of the type I IFN receptor, Tyk2/Jak1,

and STAT2, inhibiting phosphorylation of both Tyk2 and Jak1 (174).

Molecular Mimicry

The concept of molecular mimicry, in this context, is that a virus can elaborate proteins that can evade host immune responses by mimicking aspects of host immune function. KSHV is a herpesvirus that is well adapted to evade the immune system using molecular mimicry (122). KSHV establishes long-term latency following infection of cells where gene expression is highly restricted, and it can then undergo lytic replication. KSHV encodes a large number of immunomodulatory proteins that evade the host immune system, and these are deployed at distinct stages of its viral life cycle (175). Two viral transmembrane proteins, MIR1 and MIR2, prevent expression of MHC class I at the cell surface, and MIR2 also downregulates ICAM-1 and B7.2 (176, 177). Expression of v-FLICE inhibits induction of apoptosis by the extrinsic pathway by inhibiting death signaling (178). Cell-mediated cytotoxicity is also inhibited by the virus-encoded chemokines, v-CCL-1, v-CCL-2, and v-CCL-3, which are secreted by KSHV-infected cells, and viral complement control protein, which inactivates complement (175). HBV elicits coordinated immune responses of both the innate and adaptive types, and the virus has evolved a complex array of mechanisms to evade them, including induction of immunotolerance, mutations, molecular mimicry, and others. For example, the pre-S(21-47) sequence of HBV envelope protein is involved in binding of the virus to cell receptors and has homology to the IgA heavy-chain constant region and immunological cross-reactivity, suggesting that attachment of HBV to cells might involve secretory components representing a polymeric IgA receptor (179).

Generation of Escape Mutants

Viruses that have an RNA genome or have an RNA replicative intermediate and employ a low-fidelity polymerase may generate mutants that are antigenically different and thereby evade the immune system. HBV replicates through reverse transcription of an RNA intermediate, and hence the rate of appearance of mutant viruses is high. Selection pressure to evade host immune clearance readily selects out escape mutants (180). The primary events mediating clearance of HBV from the liver and contributing to liver damage are effected by cytotoxic T cells, with 90% of acutely infected adults resolving all clinical symptoms (181). Mutations in viral genes may cause nonresponsiveness to viral antigens, and these have been reported in the precore/core gene, polymerase sequence, and pre-S/S region (182).

In the case of the RNA virus HTLV-1, in spite of the error-prone nature of reverse transcription, HTLV-1 isolates are remarkably similar in sequence, unlike other retroviruses, e.g., HIV-1. While in HTLV-1 infection, about a third of peripheral blood mononuclear cells and half of CD4⁺ cells are proliferating provirus-containing cells, in ATL, the tumor cells are mainly CD4⁺, CD25⁺ mature T cells and virions, and viral mRNA or proteins are difficult to detect, but strong antiviral antibody and cellular immune responses are readily detectable, especially against Tax (17). Even with the host antiviral immune response, HTLV-1 is able to persist by deploying other strategies as described above. In contrast, HCV is an RNA virus, and the intrinsic infidelity of the HCV RNA polymerase generates many quasispecies, helping immune evasion (172).

Other Strategies

A variety of other strategies have been employed by human oncoviruses to avoid immune responses. One simple one is to just express proteins at a very low level: HTLV-1 downregulates the levels of viral gene expression but still persists through the proliferation of infected cells harboring the latent viral episome (17). HPV has evolved multiple strategies of immune evasion so as to persist in squamous epithelia for enough time to complete the viral replicative life cycle. This persistent HPV infection is the principal risk factor for developing HPV-associated precancerous lesions and cancers. Clearance of HPV-induced lesions involves cellular immune responses, and the interplay of these responses with viral immune evasion mechanisms determines whether HPV infection is cleared or persists (161). The virus is able to maintain a low profile, since it exclusively infects epithelial cells and its replicative cycle occurs outside the basement membrane away from immune effector cells. Also, viral proteins are not secreted but are expressed mainly at low levels in the nuclei of infected cells early in infection by the viral gene repressor protein E2 and usage of rare codons, which limits viral protein translation. During the later stages of infection, viral protein expression occurs only in the keratinocytes of the upper layers of the epithelium, where access by the immune system is limited, and indeed HPV infection does not involve viremia, cell death, or cell lysis upon viral shedding. In this way, HPV avoids activation of antigen-presenting cells, production of cytokines, and initiation of the immune response (161). Current models of papillomavirus latency propose that HPV resides in the basal epithelial stem cell pool and episodically reactivates upon stem cell division. Immunosurveillance memory T cells resident in the tissue are thought to control the extent and duration of these reactivation episodes (183, 184).

Finally, not much is known about the interactions of the most recently discovered human oncovirus, MCV. It is important to note that MCV is different from the other six human oncoviruses in that carcinogenesis is an endpoint that lies beyond the viral life cycle, and so viral replication is not occurring and mechanisms of maintaining viral persistence in the face of the immune system are not in play. As noted above, immunosuppression is an important predisposing factor in the development of Merkel cell carcinoma (62). Iyer et al. (185) found T-cell responsiveness to MCV T antigen in tumor-infiltrating lymphocytes from MCC tumor tissues, showing that MCC tumors are able to develop despite the presence of T cells specific for this oncoprotein (185). Recently, MCV large T antigen was found to inhibit TLR9 expression (170).

CONCLUSIONS AND FUTURE DIRECTIONS

Over many years of cancer research, the role of viruses in oncogenesis has been much debated. We now have a consensus that seven different viruses are likely to have a causal role in human cancer (Table 1). Much progress has been made over the last 30 years, and now the evidence is convincing that oncoviruses account for about 20% of human cancers worldwide (17). Research on these viruses and the molecular mechanisms involved in the pathologies they produce is still ongoing, and indeed these areas of research have gone hand in hand with the advancement of basic cancer research for decades. It remains to be seen if there will be more viruses that will be implicated in the etiology of human cancers. In this regard, there are two possibilities.

First, it is possible that hitherto-unknown viruses will be identified as cancer agents. Technical advancements in molecular bi-

ology continue apace, and they may reveal new agents that might not be apparent with the use of classical virological approaches. For example, KSHV was discovered by representational difference analysis, which is a method that compares PCR products from diseased tissue to those from nondiseased tissue obtained from the same patient, thus allowing the identification and characterization of unique DNA sequences that are specific to the disease (50). Similarly, the most recent human oncovirus to be discovered, MCV, was found through high-throughput sequence analysis of RNA transcripts from Merkel cell carcinoma and then computational removal of host sequences known from high-quality reference genome data (digital transcriptome subtraction). By this method, a novel transcript with a sequence that had homology to the then-known polyomaviruses was identified, leading to the discovery of MCV (56). Thus, it is perhaps likely that unknown viruses exist that are associated with human cancers and may be identified in the future. In this regard, the number of members of the family of human polyomaviruses has expanded rapidly in recent years, and the roles of most of these in human diseases remain unknown (57).

Second, there are viruses that are reported to be associated with human cancer but for which there have not been sufficient consistent data to establish a consensus in the field on their etiological role in cancer. Examples include the polyomaviruses JCV and BKV. JCV has long been the established agent of the central nervous system (CNS) demyelinating disease progressive multifocal encephalopathy, which is caused by lytic replication of the virus in glial cells. JCV causes tumors in experimental animals, and there have been reports of the presence of JCV DNA and proteins in brain tumors and other human cancers but also reports to the contrary (58–60), and this is further complicated by reports of JCV DNA in normal brain tissue (186). Infection by the virus also is very common, making epidemiological studies difficult, and there are other issues, which were raised in The Issue of Establishing Causality above. It is possible that further research into JCV will further clarify its role in human cancer.

Another virus that has gained attention for a possible role in cancer is the betaherpesvirus human cytomegalovirus (HCMV), which has been suggested to be involved in a variety of brain tumors (187), including gliomas (188) and medulloblastomas (189), based on treatment data for animal models and patients (187, 188, 189). Moreover, there are many reports that HCMV can dysregulate signaling pathways involved in cell transformation and malignancy (187), including tumor suppressors (p53, Rb, and cyclins) and mitogenic signaling (PI3K/Akt, Erk, Wnt, and NF- κ B), as well as the inflammatory response, immune evasion, angiogenesis, and invasion (190). However, as with JCV, infection in the human population is very common, and the ubiquitous nature of infection and the frequent persistence of HCMV in normal as well as cancer tissue make it very difficult to evaluate its role in human cancer (17).

Finally and most importantly, the expression of virus-specific antigens by human tumors offers a huge opportunity to develop preventive and therapeutic options. Already vaccines for HBV and HPV are available and widely used. Of note, the vaccines Cervarix and Gardasil have been developed against HPV, and both vaccines have proven to be almost 100% effective in preventing disease caused by the high-risk HPV types, HPV16 and -18, which together account for 70% of all cervical cancers, as well as other anogenital cancers. The development of novel therapeutics that

exploit virus-specific proteins, such as immunotherapy, targeted monoclonal antibodies, and small-molecule inhibitors, is an important future goal.

ACKNOWLEDGMENTS

We thank past and present members of the Department of Neuroscience and Center for Neurovirology for their continued support, insightful discussion, and sharing of reagents and ideas. We also thank C. Papaleo for editorial assistance.

REFERENCES

- Harris H. 2005. A long view of fashions in cancer research. *Bioessays* 27:833–838. <http://dx.doi.org/10.1002/bies.20263>.
- Rous P. 1911. A sarcoma of the fowl transmissible by an agent separable from the tumor cells. *J. Exp. Med.* 13:397–411. <http://dx.doi.org/10.1084/jem.13.4.397>.
- Stehelin D, Varmus HE, Bishop JM, Vogt PK. 1976. DNA related to the transforming gene(s) of avian sarcoma viruses is present in normal avian DNA. *Nature* 260:170–173. <http://dx.doi.org/10.1038/260170a0>.
- Baker SJ, Markowitz S, Fearon ER, Willson JK, Vogelstein B. 1990. Suppression of human colorectal carcinoma cell growth by wild-type p53. *Science* 249:912–915. <http://dx.doi.org/10.1126/science.2144057>.
- Harris H, Miller OJ, Klein G, Worst P, Tachibana T. 1969. Suppression of malignancy by cell fusion. *Nature* 223:363–368. <http://dx.doi.org/10.1038/223363a0>.
- Hanahan D, Weinberg RA. 2011. Hallmarks of cancer: the next generation. *Cell* 144:646–674. <http://dx.doi.org/10.1016/j.cell.2011.02.013>.
- Rubin AL, Yao A, Rubin H. 1990. Relation of spontaneous transformation in cell culture to adaptive growth and clonal heterogeneity. *Proc. Natl. Acad. Sci. U. S. A.* 87:482–486. <http://dx.doi.org/10.1073/pnas.87.1.482>.
- Yao A, Rubin AL, Rubin H. 1990. Progressive state selection of cells in low serum promotes high density growth and neoplastic transformation in NIH 3T3 cells. *Cancer Res.* 50:5171–5176.
- Boone CW. 1975. Malignant hemangioendotheliomas produced by subcutaneous inoculation of Balb/3T3 cells attached to glass beads. *Science* 188:68–70. <http://dx.doi.org/10.1126/science.1114343>.
- Boone CW, Takeichi N, Paranjpe M, Gilden R. 1976. Vasoformative sarcomas arising from BALB/3T3 cells attached to solid substrates. *Cancer Res.* 36:1626–1633.
- Weiss RA, Vogt PK. 2011. 100 years of Rous sarcoma virus. *J. Exp. Med.* 208:2351–2355. <http://dx.doi.org/10.1084/jem.20112160>.
- Javier RT, Butel JS. 2008. The history of tumor virology. *Cancer Res.* 68:7693–7706. <http://dx.doi.org/10.1158/0008-5472.CAN-08-3301>.
- Shope RE. 1932. A filtrable virus causing a tumor-like condition in rabbits and its relationship to virus myxomatousum. *J. Exp. Med.* 56:803–822. <http://dx.doi.org/10.1084/jem.56.6.803>.
- Bittner JJ. 1936. Some possible effects of nursing on the mammary gland tumor incidence in mice. *Science* 84:162. <http://dx.doi.org/10.1126/science.84.2172.162-a>.
- Gross L. 1951. “Spontaneous” leukemia developing in C3H mice following inoculation in infancy, with AK-leukemic extracts, or AK-embryos. *Proc. Soc. Exp. Biol. Med.* 76:27–32. <http://dx.doi.org/10.3181/00379727-76-18379>.
- Stewart SE, Eddy BE, Borgese N. 1958. Neoplasms in mice inoculated with a tumor agent carried in tissue culture. *J. Natl. Cancer Inst.* 20:1223–1243.
- Zur Hausen H. 2006. *Infections causing human cancer*. Wiley, New York, NY.
- Pagano JS. 1999. Epstein-Barr virus: the first human tumor virus and its role in cancer. *Proc. Assoc. Am. Physicians* 111:573–580. <http://dx.doi.org/10.1046/j.1525-1381.1999.t01-1-99220.x>.
- Epstein MA, Achong BG, Barr YM. 1964. Virus particles in cultured lymphoblasts from Burkitt’s lymphoma. *Lancet* i:702–703.
- Henle G, Henle W, Clifford P, Diehl V, Kafuko GW, Kirya BG, Klein G, Morrow RH, Munford GM, Pike P, Tukei J, Ziegler JL. 1969. Antibodies to Epstein-Barr virus in Burkitt’s lymphoma and control groups. *J. Natl. Cancer Inst.* 43:1147–1157.
- Henle W, Henle G, Zajac BA, Pearson G, Waubke R, Scriba M. 1970. Differential reactivity of human serums with early antigens induced by Epstein-Barr virus. *Science* 169:188–190. <http://dx.doi.org/10.1126/science.169.3941.188>.
- Nonoyama M, Kawai Y, Pagano JS. 1975. Detection of Epstein-Barr virus DNA in human tumors. *Bibl. Haematol.* 40:577–583.
- Baer R, Bankier AT, Biggin MD, Deininger PL, Farrell PJ, Gibson TJ, Hatfull G, Hudson GS, Satchwell SC, Seguin C, Tuffnell PS, Barrell BG. 1984. DNA sequence and expression of the B95–8 Epstein-Barr virus genome. *Nature* 310:207–211. <http://dx.doi.org/10.1038/310207a0>.
- Adams A, Lindahl T. 1975. Epstein-Barr virus genomes with properties of circular DNA molecules in carrier cells. *Proc. Natl. Acad. Sci. U. S. A.* 72:1477–1481. <http://dx.doi.org/10.1073/pnas.72.4.1477>.
- Lemon SM, Hutt LM, Shaw JE, Li JL, Pagano JS. 1977. Replication of EBV in epithelial cells during infectious mononucleosis. *Nature* 268:268–270. <http://dx.doi.org/10.1038/268268a0>.
- Sixbey JW, Nedrud JG, Raab-Traub N, Hanes RA, Pagano JS. 1984. Epstein-Barr virus replication in oropharyngeal epithelial cells. *N. Engl. J. Med.* 310:1225–1230. <http://dx.doi.org/10.1056/NEJM198405103101905>.
- Dane DS, Cameron CH, Briggs M. 1970. Virus-like particles in serum of patients with Australia-antigen-associated hepatitis. *Lancet* i:695–698.
- Robinson WS, Clayton DA, Greenman RL. 1974. DNA of a human hepatitis B virus candidate. *J. Virol.* 14:384–391.
- Beasley RP, Hwang LY, Lin CC, Chien CS. 1981. Hepatocellular carcinoma and hepatitis B virus. A prospective study of 22 707 men in Taiwan. *Lancet* ii:1129–1133.
- Wright R. 1990. Viral hepatitis comparative epidemiology. *Br. Med. Bull.* 46:548–558.
- zur Hausen H. 1977. Human papillomaviruses and their possible role in squamous cell carcinomas. *Curr. Top. Microbiol. Immunol.* 78:1–30.
- zur Hausen H, Meinhof W, Scheiber W, Bornkamm GW. 1974. Attempts to detect virus-specific DNA in human tumors. I. Nucleic acid hybridizations with complementary RNA of human wart virus. *Int. J. Cancer* 13:650–656.
- zur Hausen H, Schulte-Holthausen H, Wolf H, Dorries K, Egger H. 1974. Attempts to detect virus-specific DNA in human tumors. II. Nucleic acid hybridizations with complementary RNA of human herpes group viruses. *Int. J. Cancer* 13:657–664.
- Boshart M, Gissmann L, Ikenberg H, Kleinheinz A, Scheurlen W, zur Hausen H. 1984. A new type of papillomavirus DNA, its presence in genital cancer biopsies and in cell lines derived from cervical cancer. *EMBO J.* 3:1151–1157.
- Durst M, Gissmann L, Ikenberg H, zur Hausen H. 1983. A papillomavirus DNA from a cervical carcinoma and its prevalence in cancer biopsy samples from different geographic regions. *Proc. Natl. Acad. Sci. U. S. A.* 80:3812–3815. <http://dx.doi.org/10.1073/pnas.80.12.3812>.
- Danos O, Katinka M, Yaniv M. 1982. Human papillomavirus 1a complete DNA sequence: a novel type of genome organization among papovaviridae. *EMBO J.* 1:231–236.
- Schiffman M, Castle PE. 2003. Human papillomavirus: epidemiology and public health. *Arch. Path. Lab. Med.* 127:930–934.
- Yoshida M, Miyoshi I, Hinuma Y. 1982. Isolation and characterization of retrovirus from cell lines of human adult T-cell leukemia and its implication in the disease. *Proc. Natl. Acad. Sci. U. S. A.* 79:2031–2035. <http://dx.doi.org/10.1073/pnas.79.6.2031>.
- Seiki M, Hattori S, Hirayama Y, Yoshida M. 1983. Human adult T-cell leukemia virus: complete nucleotide sequence of the provirus genome integrated in leukemia cell DNA. *Proc. Natl. Acad. Sci. U. S. A.* 80:3618–3622. <http://dx.doi.org/10.1073/pnas.80.12.3618>.
- Poiesz BJ, Ruscetti FW, Gazdar AF, Bunn PA, Minna JD, Gallo RC. 1980. Detection and isolation of type C retrovirus particles from fresh and cultured lymphocytes of a patient with cutaneous T-cell lymphoma. *Proc. Natl. Acad. Sci. U. S. A.* 77:7415–7419. <http://dx.doi.org/10.1073/pnas.77.12.7415>.
- Lairmore MD, Haines R, Anupam R. 2012. Mechanisms of human T-lymphotropic virus type 1 transmission and disease. *Curr. Opin. Virol.* 2:474–481. <http://dx.doi.org/10.1016/j.coviro.2012.06.007>.
- Taylor GP, Matsuoka M. 2005. Natural history of adult T-cell leukemia/lymphoma and approaches to therapy. *Oncogene* 24:6047–6057. <http://dx.doi.org/10.1038/sj.onc.1208979>.
- Sonoda S, Li HC, Tajima K. 2011. Ethnoepidemiology of HTLV-1 related diseases: ethnic determinants of HTLV-1 susceptibility and its worldwide dispersal. *Cancer Sci.* 102:295–301. <http://dx.doi.org/10.1111/j.1349-7006.2010.01820.x>.
- Feinstone SM, Kapikian AZ, Purcell RH, Alter HJ, Holland PV. 1975.

- Transfusion-associated hepatitis not due to viral hepatitis type A or B. *N. Engl. J. Med.* 292:767–770. <http://dx.doi.org/10.1056/NEJM197504102921502>.
45. Choo QL, Kuo G, Weiner AJ, Overby LR, Bradley DW, Houghton M. 1989. Isolation of a cDNA clone derived from a blood-borne non-A, non-B viral hepatitis genome. *Science* 244:359–362. <http://dx.doi.org/10.1126/science.2523562>.
 46. Gravitz L. 2011. A smouldering public-health crisis. *Nature* 474:S2–S4. <http://dx.doi.org/10.1038/474S2a>.
 47. Rosen HR. 2011. Clinical practice. Chronic hepatitis C infection. *N. Engl. J. Med.* 364:2429–2438. <http://dx.doi.org/10.1056/NEJMcp1006613>.
 48. Hoofnagle JH. 2002. Course and outcome of hepatitis C. *Hepatology* 36:S21–29. <http://dx.doi.org/10.1053/jhep.2002.36227>.
 49. Larney S, Kopinski H, Beckwith CG, Zaller ND, Jarlais DD, Hagan H, Rich JD, van den Bergh BJ, Degenhardt L. 2013. Incidence and prevalence of hepatitis C in prisons and other closed settings: results of a systematic review and meta-analysis. *Hepatology* 58:1215–1224. <http://dx.doi.org/10.1002/hep.26387>.
 50. Chang Y, Cesarman E, Pessin MS, Lee F, Culpepper J, Knowles DM, Moore PS. 1994. Identification of herpesvirus-like DNA sequences in AIDS-associated Kaposi's sarcoma. *Science* 266:1865–1869. <http://dx.doi.org/10.1126/science.7997879>.
 51. Cesarman E, Chang Y, Moore PS, Said JW, Knowles DM. 1995. Kaposi's sarcoma-associated herpesvirus-like DNA sequences in AIDS-related body-cavity-based lymphomas. *N. Engl. J. Med.* 332:1186–1191. <http://dx.doi.org/10.1056/NEJM199505043321802>.
 52. Soulier J, Grollet L, Oksenhendler E, Cacoub P, Cazals-Hatem D, Babinet P, d'Agay MF, Clauvel JP, Raphael M, Degos L, et al. 1995. Kaposi's sarcoma-associated herpesvirus-like DNA sequences in multicentric Castlemann's disease. *Blood* 86:1276–1280.
 53. Corbellino M, Poirel L, Aubin JT, Paulli M, Magrini U, Bestetti G, Galli M, Parravicini C. 1996. The role of human herpesvirus 8 and Epstein-Barr virus in the pathogenesis of giant lymph node hyperplasia (Castlemann's disease). *Clin. Infect. Dis.* 22:1120–1121. <http://dx.doi.org/10.1093/clinids/22.6.1120>.
 54. Russo JJ, Bohenzky RA, Chien MC, Chen J, Yan M, Maddalena D, Parry JP, Peruzzi D, Edelman IS, Chang Y, Moore PS. 1996. Nucleotide sequence of the Kaposi sarcoma-associated herpesvirus (HHV8). *Proc. Natl. Acad. Sci. U. S. A.* 93:14862–14867. <http://dx.doi.org/10.1073/pnas.93.25.14862>.
 55. Akula SM, Pramod NP, Wang FZ, Chandran B. 2002. Integrin alpha3beta1 (CD 49c/29) is a cellular receptor for Kaposi's sarcoma-associated herpesvirus (KSHV/HHV-8) entry into the target cells. *Cell* 108:407–419. [http://dx.doi.org/10.1016/S0092-8674\(02\)00628-1](http://dx.doi.org/10.1016/S0092-8674(02)00628-1).
 56. Feng H, Taylor JL, Benos PV, Newton R, Waddell K, Lucas SB, Chang Y, Moore PS. 2007. Human transcriptome subtraction by using short sequence tags to search for tumor viruses in conjunctival carcinoma. *J. Virol.* 81:11332–11340. <http://dx.doi.org/10.1128/JVI.00875-07>.
 57. White MK, Gordon J, Khalili K. 2013. The rapidly expanding family of human polyomaviruses: recent developments in understanding their life cycle and role in human pathology. *PLoS Pathog.* 9:e1003206. <http://dx.doi.org/10.1371/journal.ppat.1003206>.
 58. White MK, Khalili K. 2004. Polyomaviruses and human cancer: molecular mechanisms underlying patterns of tumorigenesis. *Virology* 324:1–16. <http://dx.doi.org/10.1016/j.virol.2004.03.025>.
 59. White MK, Khalili K. 2005. Expression of JC virus regulatory proteins in human cancer: potential mechanisms for tumorigenesis. *Eur. J. Cancer.* 41:2537–2548. <http://dx.doi.org/10.1016/j.ejca.2005.08.019>.
 60. White MK, Gordon J, Reiss K, Del Valle L, Croul S, Giordano A, Darbinyan A, Khalili K. 2005. Human polyomaviruses and brain tumors. *Brain Res. Rev.* 50:69–85. <http://dx.doi.org/10.1016/j.brainresrev.2005.04.007>.
 61. Schrama D, Ugurel S, Becker JC. 2012. Merkel cell carcinoma: recent insights and new treatment options. *Curr. Opin. Oncol.* 24:141–149. <http://dx.doi.org/10.1097/CCO.0b013e32834fc9fe>.
 62. Bichakjian CK, Lowe L, Lao CD, Sandler HM, Bradford CR, Johnson TM, Wong SL. 2007. Merkel cell carcinoma: critical review with guidelines for multidisciplinary management. *Cancer* 110:1–12. <http://dx.doi.org/10.1002/cncr.22765>.
 63. Duncavage EJ, Zehnbauser BA, Pfeifer JD. 2009. Prevalence of Merkel cell polyomavirus in Merkel cell carcinoma. *Mod. Pathol.* 22:516–521. <http://dx.doi.org/10.1038/modpathol.2009.3>.
 64. Sastre-Garau X, Peter M, Avril MF, Laude H, Couturier J, Rozenberg F, Almeida A, Boitier F, Carloti A, Couturaud B, Dupin N. 2009. Merkel cell carcinoma of the skin: pathological and molecular evidence for a causative role of MCV in oncogenesis. *J. Pathol.* 218:48–56. <http://dx.doi.org/10.1002/path.2532>.
 65. Mangana J, Dziunycz P, Kerl K, Dummer R, Cozzio A. 2010. Prevalence of Merkel cell polyomavirus among Swiss Merkel cell carcinoma patients. *Dermatology* 221:184–188. <http://dx.doi.org/10.1159/000315067>.
 66. Martel-Jantin C, Filippone C, Cassar O, Peter M, Tomasic G, Vielh P, Briere J, Petrella T, Aubriot-Lorton MH, Mortier L, Jouvion G, Sastre-Garau X, Robert C, Gessain A. 2012. Genetic variability and integration of Merkel cell polyomavirus in Merkel cell carcinoma. *Virology* 426:134–142. <http://dx.doi.org/10.1016/j.virol.2012.01.018>.
 67. Shuda M, Feng H, Kwun HJ, Rosen ST, Gjoerup O, Moore PS, Chang Y. 2008. T antigen mutations are a human tumor-specific signature for Merkel cell polyomavirus. *Proc. Natl. Acad. Sci. U. S. A.* 105:16272–16277. <http://dx.doi.org/10.1073/pnas.0806526105>.
 68. Chen T, Hedman L, Mattila PS, Jartti T, Ruuskanen O, Soderlund-Venermo M, Hedman K. 2011. Serological evidence of Merkel cell polyomavirus primary infections in childhood. *J. Clin. Virol.* 50:125–129. <http://dx.doi.org/10.1016/j.jcv.2010.10.015>.
 69. Kean JM, Rao S, Wang M, Garcea RL. 2009. Seroepidemiology of human polyomaviruses. *PLoS Pathog.* 5:e1000363. <http://dx.doi.org/10.1371/journal.ppat.1000363>.
 70. Tolstov YL, Pastrana DV, Feng H, Becker JC, Jenkins FJ, Moschos S, Chang Y, Buck CB, Moore PS. 2009. Human Merkel cell polyomavirus infection. II. MCV is a common human infection that can be detected by conformational capsid epitope immunoassays. *Int. J. Cancer* 125:1250–1256. <http://dx.doi.org/10.1002/ijc.24509>.
 71. Arora R, Chang Y, Moore PS. 2012. MCV and Merkel cell carcinoma: a molecular success story. *Curr. Opin. Virol.* 2:489–498. <http://dx.doi.org/10.1016/j.coviro.2012.05.007>.
 72. Pagano JS, Blaser M, Buendia MA, Damania B, Khalili K, Raab-Traub N, Roizman B. 2004. Infectious agents and cancer: criteria for a causal relation. *Semin. Cancer Biol.* 14:453–471. <http://dx.doi.org/10.1016/j.semcancer.2004.06.009>.
 73. Koch R. 1881. Zer Untersuchung van pathogenen Organismen. *Mittheil. Kais. Gesundheitsamte* 1:1–48.
 74. Evans AS, Mueller NE. 1990. Viruses and cancer. Causal associations. *Ann. Epidemiol.* 1:71–92. [http://dx.doi.org/10.1016/1047-2797\(90\)90020-S](http://dx.doi.org/10.1016/1047-2797(90)90020-S).
 75. Agelli M, Clegg LX. 2003. Epidemiology of primary Merkel cell carcinoma in the United States. *J. Am. Acad. Dermatol.* 49:832–841. [http://dx.doi.org/10.1016/S0190-9622\(03\)02108-X](http://dx.doi.org/10.1016/S0190-9622(03)02108-X).
 76. Korzeniewski N, Spardy N, Duensing A, Duensing S. 2011. Genomic instability and cancer: lessons learned from human papillomaviruses. *Cancer Lett.* 305:113–122. <http://dx.doi.org/10.1016/j.canlet.2010.10.013>.
 77. Hill AB. 1965. The environment and disease: association or causation? *Proc. R. Soc. Med.* 58:295–300.
 78. Bosch X. 1981. Risk factors in human cancer. *Rev. Sanidad Hig. Publica* 55:477–480.
 79. Bility MT, Li F, Cheng L, Su L. 2013. Liver immune-pathogenesis and therapy of human liver tropic virus infection in humanized mouse models. *J. Gastroenterol. Hepatol.* 28(Suppl 1):120–124. <http://dx.doi.org/10.1111/jgh.12092>.
 80. Akkina R. 2013. Human immune responses and potential for vaccine assessment in humanized mice. *Curr. Opin. Immunol.* 25:403–409. <http://dx.doi.org/10.1016/j.coi.2013.03.009>.
 81. Clifford GM, Polesel J, Rickenbach M, Dal Maso L, Keiser O, Kofler A, Rapiti E, Levi F, Jundt G, Fisch T, Bordoni A, De Weck D, Franceschi S. 2005. Cancer risk in the Swiss HIV Cohort Study: associations with immunodeficiency, smoking, and highly active antiretroviral therapy. *J. Natl. Cancer Inst.* 97:425–432. <http://dx.doi.org/10.1093/jnci/dji072>.
 82. Jensen F, Koprowski H, Ponten JA. 1963. Rapid transformation of human fibroblast cultures by simian virus. *Proc. Natl. Acad. Sci. U. S. A.* 50:343–348. <http://dx.doi.org/10.1073/pnas.50.2.343>.
 83. Lane DP, Crawford LV. 1979. T antigen is bound to a host protein in SV40-transformed cells. *Nature* 278:261–263. <http://dx.doi.org/10.1038/278261a0>.
 84. Whyte P, Buchkovich KJ, Horowitz JM, Friend SH, Raybuck M, Weinberg RA, Harlow E. 1988. Association between an oncogene and an anti-oncogene: the adenovirus E1A proteins bind to the retinoblastoma gene product. *Nature* 334:124–129. <http://dx.doi.org/10.1038/334124a0>.
 85. Martinez R, Nakamura KD, Weber MJ. 1982. Identification of phos-

- photyrosine-containing proteins in untransformed and Rous sarcoma virus-transformed chicken embryo fibroblasts. *Mol. Cell. Biol.* 2:653–665.
86. Rossomando AJ, Payne DM, Weber MJ, Sturgill TW. 1989. Evidence that pp42, a major tyrosine kinase target protein, is a mitogen-activated serine/threonine protein kinase. *Proc. Natl. Acad. Sci. U. S. A.* 86:6940–6943. <http://dx.doi.org/10.1073/pnas.86.18.6940>.
 87. Hamid NA, Brown C, Gaston K. 2009. The regulation of cell proliferation by the papillomavirus early proteins. *Cell Mol. Life Sci.* 66:1700–1717. <http://dx.doi.org/10.1007/s0018-009-8631-7>.
 88. Pett MR, Alazawi WO, Roberts I, Downen S, Smith DI, Stanley MA, Coleman N. 2004. Acquisition of high-level chromosomal instability is associated with integration of human papillomavirus type 16 in cervical keratinocytes. *Cancer Res.* 64:1359–1368. <http://dx.doi.org/10.1158/0008-5472.CAN-03-3214>.
 89. Munger K, Baldwin A, Edwards KM, Hayakawa H, Nguyen CL, Owens M, Grace M, Huh K. 2004. Mechanisms of human papillomavirus-induced oncogenesis. *J. Virol.* 78:11451–11460. <http://dx.doi.org/10.1128/JVI.78.21.11451-11460.2004>.
 90. Storey A, Banks L. 1993. Human papillomavirus type 16 E6 gene cooperates with EJ-ras to immortalize primary mouse cells. *Oncogene* 8:919–924.
 91. Lambert PF, Pan H, Pitot HC, Liem A, Jackson M, Griep AE. 1993. Epidermal cancer associated with expression of human papillomavirus type 16 E6 and E7 oncogenes in the skin of transgenic mice. *Proc. Natl. Acad. Sci. U. S. A.* 90:5583–5587. <http://dx.doi.org/10.1073/pnas.90.12.5583>.
 92. Song S, Liem A, Miller JA, Lambert PF. 2000. Human papillomavirus types 16 E6 and E7 contribute differently to carcinogenesis. *Virology* 267:141–150. <http://dx.doi.org/10.1006/viro.1999.0106>.
 93. Kiyono T, Foster SA, Koop JI, McDougall JK, Galloway DA, Klingel-hutz AJ. 1998. Both Rb/p16INK4a inactivation and telomerase activity are required to immortalize human epithelial cells. *Nature* 396:84–88. <http://dx.doi.org/10.1038/23962>.
 94. Meyers JM, Spangle JM, Munger K. 2013. The human papillomavirus type 8 E6 protein interferes with NOTCH activation during keratinocyte differentiation. *J. Virol.* 87:4762–4767. <http://dx.doi.org/10.1128/JVI.02527-12>.
 95. Munger K, Howley PM. 2002. Human papillomavirus immortalization and transformation functions. *Virus Res.* 89:213–228. [http://dx.doi.org/10.1016/S0168-1702\(02\)00190-9](http://dx.doi.org/10.1016/S0168-1702(02)00190-9).
 96. Vande Pol SB, Klingelhutz AJ. 2013. Papillomavirus E6 oncoproteins. *Virology* 445:115–137. <http://dx.doi.org/10.1016/j.virol.2013.04.026>.
 97. McLaughlin-Drubin ME, Munger K. 2009. The human papillomavirus E7 oncoprotein. *Virology* 384:335–344. <http://dx.doi.org/10.1016/j.virol.2008.10.006>.
 98. Beaudenon S, Huibregtse JM. 2008. HPV E6, E6AP and cervical cancer. *BMC Biochem.* 9(Suppl 1):S4. <http://dx.doi.org/10.1186/1471-2091-9-S1-S4>.
 99. Mantovani F, Banks L. 2001. The human papillomavirus E6 protein and its contribution to malignant progression. *Oncogene* 20:7874–7887. <http://dx.doi.org/10.1038/sj.onc.1204869>.
 100. Felsani A, Mileo AM, Paggi MG. 2006. Retinoblastoma family proteins as key targets of the small DNA virus oncoproteins. *Oncogene* 25:5277–5285. <http://dx.doi.org/10.1038/sj.onc.1209621>.
 101. Rowe M, Lear AL, Croom-Carter D, Davies AH, Rickinson AB. 1992. Three pathways of Epstein-Barr virus gene activation from EBNA1-positive latency in B lymphocytes. *J. Virol.* 66:122–131.
 102. Rawlins DR, Milman G, Hayward SD, Hayward GS. 1985. Sequence-specific DNA binding of the Epstein-Barr virus nuclear antigen (EBNA-1) to clustered sites in the plasmid maintenance region. *Cell* 42:859–868. [http://dx.doi.org/10.1016/0092-8674\(85\)90282-X](http://dx.doi.org/10.1016/0092-8674(85)90282-X).
 103. Westhoff Smith D, Sugden B. 2013. Potential cellular functions of Epstein-Barr nuclear antigen 1 (EBNA1) of Epstein-Barr virus. *Viruses* 5:226–240. <http://dx.doi.org/10.3390/v510226>.
 104. Knutson JC. 1990. The level of c-fgr RNA is increased by EBNA-2, an Epstein-Barr virus gene required for B-cell immortalization. *J. Virol.* 64:2530–2536.
 105. Henkel T, Ling PD, Hayward SD, Peterson MG. 1994. Mediation of Epstein-Barr virus EBNA2 transactivation by recombination signal-binding protein J. kappa. *Science* 265:92–95. <http://dx.doi.org/10.1126/science.8016657>.
 106. Hayward SD, Liu J, Fujimuro M. 2006. Notch and Wnt signaling: mimicry and manipulation by gamma herpesviruses. *Sci. STKE* 2006:re4. <http://dx.doi.org/10.1126/stke.3352006re4>.
 107. Bheda A, Yue W, Gullapalli A, Shackelford J, Pagano JS. 2011. PU.1-dependent regulation of UCH L1 expression in B-lymphoma cells. *Leuk. Lymphoma* 52:1336–1347. <http://dx.doi.org/10.3109/10428194.2011.562571>.
 108. Abbot SD, Rowe M, Cadwallader K, Ricksten A, Gordon J, Wang F, Rymo L, Rickinson AB. 1990. Epstein-Barr virus nuclear antigen 2 induces expression of the virus-encoded latent membrane protein. *J. Virol.* 64:2126–2134.
 109. Wakisaka N, Pagano JS. 2003. Epstein-Barr virus induces invasion and metastasis factors. *Anticancer Res.* 23:2133–2138.
 110. Dawson CW, Port RJ, Young LS. 2012. The role of the EBV-encoded latent membrane proteins LMP1 and LMP2 in the pathogenesis of nasopharyngeal carcinoma (NPC). *Semin. Cancer Biol.* 22:144–153. <http://dx.doi.org/10.1016/j.semcancer.2012.01.004>.
 111. Pang MF, Lin KW, Peh SC. 2009. The signaling pathways of Epstein-Barr virus-encoded latent membrane protein 2A (LMP2A) in latency and cancer. *Cell Mol. Biol. Lett.* 14:222–247. <http://dx.doi.org/10.2478/s11658-008-0045-2>.
 112. Calender A, Cordier M, Billaud M, Lenoir GM. 1990. Modulation of cellular gene expression in B lymphoma cells following in vitro infection by Epstein-Barr virus (EBV). *Int. J. Cancer* 46:658–663. <http://dx.doi.org/10.1002/ijc.2910460418>.
 113. Moorthy RK, Thorley-Lawson DA. 1993. All three domains of the Epstein-Barr virus-encoded latent membrane protein LMP-1 are required for transformation of rat-1 fibroblasts. *J. Virol.* 67:1638–1646.
 114. Iwakiri D, Takada K. 2010. Role of EBERs in the pathogenesis of EBV infection. *Adv. Cancer Res.* 107:119–136. [http://dx.doi.org/10.1016/S0065-230X\(10\)07004-1](http://dx.doi.org/10.1016/S0065-230X(10)07004-1).
 115. Nanbo A, Takada K. 2002. The role of Epstein-Barr virus-encoded small RNAs (EBERs) in oncogenesis. *Rev. Med. Virol.* 12:321–326. <http://dx.doi.org/10.1002/rmv.363>.
 116. Marquitz AR, Raab-Traub N. 2012. The role of miRNAs and EBV BARTs in NPC. *Semin. Cancer Biol.* 22:166–172. <http://dx.doi.org/10.1016/j.semcancer.2011.12.001>.
 117. Radkov SA, Kellam P, Boshoff C. 2000. The latent nuclear antigen of Kaposi sarcoma-associated herpesvirus targets the retinoblastoma-E2F pathway and with the oncogene Hras transforms primary rat cells. *Nat. Med.* 6:1121–1127. <http://dx.doi.org/10.1038/80459>.
 118. Wilson JB, Bell JL, Levine AJ. 1996. Expression of Epstein-Barr virus nuclear antigen-1 induces B cell neoplasia in transgenic mice. *EMBO J.* 15:3117–3126.
 119. Drotar ME, Silva S, Barone E, Campbell D, Tsimbouri P, Jurvansu J, Bhatia P, Klein G, Wilson JB. 2003. Epstein-Barr virus nuclear antigen-1 and Myc cooperate in lymphomagenesis. *Int. J. Cancer* 106:388–395. <http://dx.doi.org/10.1002/ijc.11224>.
 120. Kang MS, Lu H, Yasui T, Sharpe A, Warren H, Cahir-McFarland E, Bronson R, Hung SC, Kieff E. 2005. Epstein-Barr virus nuclear antigen 1 does not induce lymphoma in transgenic FVB mice. *Proc. Natl. Acad. Sci. U. S. A.* 102:820–825. <http://dx.doi.org/10.1073/pnas.0408774102>.
 121. Kulwicht W, Edwards RH, Davenport EM, Baskar JF, Godfrey V, Raab-Traub N. 1998. Expression of the Epstein-Barr virus latent membrane protein 1 induces B cell lymphoma in transgenic mice. *Proc. Natl. Acad. Sci. U. S. A.* 95:11963–11968. <http://dx.doi.org/10.1073/pnas.95.20.11963>.
 122. Moore PS, Boshoff C, Weiss RA, Chang Y. 1996. Molecular mimicry of human cytokine and cytokine response pathway genes by KSHV. *Science* 274:1739–1744. <http://dx.doi.org/10.1126/science.274.5293.1739>.
 123. Verma SC, Lan K, Robertson E. 2007. Structure and function of latency-associated nuclear antigen. *Curr. Top. Microbiol. Immunol.* 312:101–136.
 124. Fujimuro M, Hayward SD. 2003. The latency-associated nuclear antigen of Kaposi's sarcoma-associated herpesvirus manipulates the activity of glycogen synthase kinase-3beta. *J. Virol.* 77:8019–8030. <http://dx.doi.org/10.1128/JVI.77.14.8019-8030.2003>.
 125. Friberg J, Jr, Kong W, Hottiger MO, Nabel GJ. 1999. p53 inhibition by the LANA protein of KSHV protects against cell death. *Nature* 402:889–894.
 126. Mesri EA, Cesarman E, Boshoff C. 2010. Kaposi's sarcoma and its associated herpesvirus. *Nat. Rev. Cancer* 10:707–719. <http://dx.doi.org/10.1038/nrc2888>.
 127. Muralidhar S, Pumfery AM, Hassani M, Sadaie MR, Kishishita M, Brady JN, Doniger J, Medvezky P, Rosenthal LJ. 1998. Identification of kaposin (open reading frame K12) as a human herpesvirus 8 (Kaposi's

- sarcoma-associated herpesvirus) transforming gene. *J. Virol.* 72:4980–4988.
128. Xu C, Zhou W, Wang Y, Qiao L. 2014. Hepatitis B virus-induced hepatocellular carcinoma. *Cancer Lett.* 345:216–222. <http://dx.doi.org/10.1016/j.canlet.2013.08.035>.
 129. Guerrieri F, Belloni L, Pediconi N, Levrero M. 2013. Molecular mechanisms of HBV-associated hepatocarcinogenesis. *Semin. Liver Dis.* 33:147–156. <http://dx.doi.org/10.1055/s-0033-1345721>.
 130. McGivern DR, Lemon SM. 2011. Virus-specific mechanisms of carcinogenesis in hepatitis C virus associated liver cancer. *Oncogene* 30:1969–1983. <http://dx.doi.org/10.1038/ncr.2010.594>.
 131. Kew MC. 2011. Hepatitis B virus x protein in the pathogenesis of hepatitis B virus-induced hepatocellular carcinoma. *J. Gastroenterol. Hepatol.* 26(Suppl 1):144–152. <http://dx.doi.org/10.1111/j.1440-1746.2010.06546.x>.
 132. Koike K, Moriya K, Iino S, Yotsuyanagi H, Endo Y, Miyamura T, Kurokawa K. 1994. High-level expression of hepatitis B virus HBx gene and hepatocarcinogenesis in transgenic mice. *Hepatology* 19:810–819. <http://dx.doi.org/10.1002/hep.1840190403>.
 133. Moriya K, Fujie H, Shintani Y, Yotsuyanagi H, Tsutsumi T, Ishibashi K, Matsuura Y, Kimura S, Miyamura T, Koike K. 1998. The core protein of hepatitis C virus induces hepatocellular carcinoma in transgenic mice. *Nat. Med.* 4:1065–1067. <http://dx.doi.org/10.1038/2053>.
 134. Sakamuro D, Furukawa T, Takegami T. 1995. Hepatitis C virus non-structural protein NS3 transforms NIH 3T3 cells. *J. Virol.* 69:3893–3896.
 135. Zemel R, Gerechet S, Greif H, Bachmatove L, Birk Y, Golan-Goldhirsh A, Kunin M, Berdichevsky Y, Benhar I, Tur-Kaspa R. 2001. Cell transformation induced by hepatitis C virus NS3 serine protease. *J. Viral Hepat.* 8:96–102. <http://dx.doi.org/10.1046/j.1365-2893.2001.00283.x>.
 136. He QQ, Cheng RX, Sun Y, Feng DY, Chen ZC, Zheng H. 2003. Hepatocyte transformation and tumor development induced by hepatitis C virus NS3 C-terminal deleted protein. *World J. Gastroenterol.* 9:474–478.
 137. Dunsford HA, Sell S, Chisari FV. 1990. Hepatocarcinogenesis due to chronic liver cell injury in hepatitis B virus transgenic mice. *Cancer Res.* 50:3400–3407.
 138. Yoshida T, Hanada T, Tokuhisa T, Kosai K, Sata M, Kohara M, Yoshimura A. 2002. Activation of STAT3 by the hepatitis C virus core protein leads to cellular transformation. *J. Exp. Med.* 196:641–653. <http://dx.doi.org/10.1084/jem.20012127>.
 139. Diao J, Garcés R, Richardson CD. 2001. X protein of hepatitis B virus modulates cytokine and growth factor related signal transduction pathways during the course of viral infections and hepatocarcinogenesis. *Cytokine Growth Factor Rev.* 12:189–205. [http://dx.doi.org/10.1016/S1359-6101\(00\)00034-4](http://dx.doi.org/10.1016/S1359-6101(00)00034-4).
 140. Feitelson MA, Zhu M, Duan LX, London WT. 1993. Hepatitis B x antigen and p53 are associated in vitro and in liver tissues from patients with primary hepatocellular carcinoma. *Oncogene* 8:1109–1117.
 141. Banerjee A, Ray RB, Ray R. 2010. Oncogenic potential of hepatitis C virus proteins. *Viruses* 2:2108–2133. <http://dx.doi.org/10.3390/v2092108>.
 142. Ishido S, Hotta H. 1998. Complex formation of the nonstructural protein 3 of hepatitis C virus with the p53 tumor suppressor. *FEBS Lett.* 438:258–262. [http://dx.doi.org/10.1016/S0014-5793\(98\)01312-X](http://dx.doi.org/10.1016/S0014-5793(98)01312-X).
 143. Saito M. 2014. Neuroimmunological aspects of human T cell leukemia virus type 1-associated myelopathy/tropical spastic paraparesis. *J. Neurovirol.* 20:164–174. <http://dx.doi.org/10.1007/s13365-013-0192-8>.
 144. Currer R, Van Duyn R, Jaworski E, Guendel J, Sampey G, Das R, Narayanan A, Kashanchi F. 2012. HTLV tax: a fascinating multifunctional co-regulator of viral and cellular pathways. *Front. Microbiol.* 3:406. <http://dx.doi.org/10.3389/fmicb.2012.00406>.
 145. Nerenberg M, Hinrichs SH, Reynolds RK, Khoury G, Jay G. 1987. The tat gene of human T-lymphotropic virus type 1 induces mesenchymal tumors in transgenic mice. *Science* 237:1324–1329. <http://dx.doi.org/10.1126/science.2888190>.
 146. Baranger AM, Palmer CR, Hamm MK, Giebler HA, Brauweiler A, Nyborg JK, Schepartz A. 1995. Mechanism of DNA-binding enhancement by the human T-cell leukaemia virus transactivator Tax. *Nature* 376:606–608. <http://dx.doi.org/10.1038/376606a0>.
 147. Chlichlia K, Khazaie K. 2010. HTLV-1 Tax: linking transformation, DNA damage and apoptotic T-cell death. *Chem. Biol. Interact.* 188:359–365. <http://dx.doi.org/10.1016/j.cbi.2010.06.005>.
 148. Seiki M, Eddy R, Shows TB, Yoshida M. 1984. Nonspecific integration of the HTLV provirus genome into adult T-cell leukaemia cells. *Nature* 309:640–642. <http://dx.doi.org/10.1038/309640a0>.
 149. Bai XT, Nicot C. 2012. Overview on HTLV-1 p12, p8, p30, p13: accomplices in persistent infection and viral pathogenesis. *Front. Microbiol.* 3:400. <http://dx.doi.org/10.3389/fmicb.2012.00400>.
 150. Nicot C, Mulloy JC, Ferrari MG, Johnson JM, Fu K, Fukumoto R, Trovato R, Fullen J, Leonard WJ, Franchini G. 2001. HTLV-1 p12(I) protein enhances STAT5 activation and decreases the interleukin-2 requirement for proliferation of primary human peripheral blood mononuclear cells. *Blood* 98:823–829. <http://dx.doi.org/10.1182/blood.V98.3.823>.
 151. Awasthi S, Sharma A, Wong K, Zhang J, Matlock EF, Rogers L, Motloch P, Takemoto S, Taguchi H, Cole MD, Luscher B, Dittrich O, Tagami H, Nakatani Y, McGee M, Girard AM, Gaughan L, Robson CN, Monnat RJ, Jr, Harrod R. 2005. A human T-cell lymphotropic virus type 1 enhancer of Myc transforming potential stabilizes Myc-TIP60 transcriptional interactions. *Mol. Cell. Biol.* 25:6178–6198. <http://dx.doi.org/10.1128/MCB.25.14.6178-6198.2005>.
 152. Houben R, Shuda M, Weinkam R, Schrama D, Feng H, Chang Y, Moore PS, Becker JC. 2010. Merkel cell polyomavirus-infected Merkel cell carcinoma cells require expression of viral T antigens. *J. Virol.* 84:7064–7072. <http://dx.doi.org/10.1128/JVI.02400-09>.
 153. Houben R, Adam C, Baeurle A, Heschbacher S, Grimm J, Angermeyer S, Henzel K, Hauser S, Elling R, Brocker EB, Gaubatz S, Becker JC, Schrama D. 2012. An intact retinoblastoma protein-binding site in Merkel cell polyomavirus large T antigen is required for promoting growth of Merkel cell carcinoma cells. *Int. J. Cancer. Int. J. Cancer* 130:847–856. <http://dx.doi.org/10.1002/ijc.26076>.
 154. Liu X, Hein J, Richardson SC, Basse PH, Toptan T, Moore PS, Gjoerup OV, Chang Y. 2011. Merkel cell polyomavirus large T antigen disrupts lysosome clustering by translocating human Vam6p from the cytoplasm to the nucleus. *J. Biol. Chem.* 286:17079–17090. <http://dx.doi.org/10.1074/jbc.M110.192856>.
 155. Shuda M, Kwun HJ, Feng H, Chang Y, Moore PS. 2011. Human Merkel cell polyomavirus small T antigen is an oncoprotein targeting the 4E-BP1 translation regulator. *J. Clin. Invest.* 121:3623–3634. <http://dx.doi.org/10.1172/JCI46323>.
 156. Kwun HJ, Shuda M, Feng H, Camacho CJ, Moore PS, Chang Y. 2013. Merkel cell polyomavirus small T antigen controls viral replication and oncoprotein expression by targeting the cellular ubiquitin ligase SCFFbw7. *Cell Host Microbe* 14:125–135. <http://dx.doi.org/10.1016/j.chom.2013.06.008>.
 157. Rensing ME, Horst D, Griffin BD, Tellam J, Zuo J, Khanna R, Rowe M, Wiertz EJ. 2008. Epstein-Barr virus evasion of CD8(+) and CD4(+) T cell immunity via concerted actions of multiple gene products. *Semin. Cancer Biol.* 18:397–408. <http://dx.doi.org/10.1016/j.semcancer.2008.10.008>.
 158. Zuo J, Currin A, Griffin BD, Shannon-Lowe C, Thomas WA, Rensing ME, Wiertz EJ, Rowe M. 2009. The Epstein-Barr virus G-protein-coupled receptor contributes to immune evasion by targeting MHC class I molecules for degradation. *PLoS Pathog.* 5:e1000255. <http://dx.doi.org/10.1371/journal.ppat.1000255>.
 159. Middeldorp JM, Pegtel DM. 2008. Multiple roles of LMP1 in Epstein-Barr virus induced immune escape. *Semin. Cancer Biol.* 18:388–396. <http://dx.doi.org/10.1016/j.semcancer.2008.10.004>.
 160. Chen Y, Cheng M, Tian Z. 2006. Hepatitis B virus down-regulates expressions of MHC class I molecules on hepatoplastoma cell line. *Cell. Mol. Immunol.* 3:373–378.
 161. Grabowska AK, Riemer AB. 2012. The invisible enemy—how human papillomaviruses avoid recognition and clearance by the host immune system. *Open Virol. J.* 6:249–256. <http://dx.doi.org/10.2174/1874357901206010249>.
 162. Georgopoulos NT, Proffitt JL, Blair GE. 2000. Transcriptional regulation of the major histocompatibility complex (MHC) class I heavy chain, TAP1 and LMP2 genes by the human papillomavirus (HPV) type 6b, 16 and 18 E7 oncoproteins. *Oncogene* 19:4930–4935. <http://dx.doi.org/10.1038/sj.onc.1203860>.
 163. Ashrafi GH, Brown DR, Fife KH, Campo MS. 2006. Down-regulation of MHC class I is a property common to papillomavirus E5 proteins. *Virus Res.* 120:208–211. <http://dx.doi.org/10.1016/j.virusres.2006.02.005>.
 164. Geiger TR, Martin JM. 2006. The Epstein-Barr virus-encoded LMP-1 oncoprotein negatively affects Tyk2 phosphorylation and interferon sig-

- naling in human B cells. *J. Virol.* 80:11638–11650. <http://dx.doi.org/10.1128/JVI.01570-06>.
165. Zhang L, Pagano JS. 1997. IRF-7, a new interferon regulatory factor associated with Epstein-Barr virus latency. *Mol. Cell. Biol.* 17:5748–5757.
 166. Ning S, Pagano JS, Barber GN. 2011. IRF7: activation, regulation, modification and function. *Genes Immun.* 12:399–414. <http://dx.doi.org/10.1038/gene.2011.21>.
 167. Guo P. 2013. Suppression of interferon-mediated antiviral immunity by hepatitis B virus: an overview of research progress. *Scand. J. Immunol.* 78:230–237. <http://dx.doi.org/10.1111/sji.12086>.
 168. Hasan UA, Bates E, Takeshita F, Biliato A, Accardi R, Bouvard V, Mansour M, Vincent I, Gissmann L, Iftner T, Sideri M, Stubenrauch F, Tommasino M. 2007. TLR9 expression and function is abolished by the cervical cancer-associated human papillomavirus type 16. *J. Immunol.* 178:3186–3197.
 169. Fathallah I, Parroche P, Gruffat H, Zannetti C, Johansson H, Yue J, Manet E, Tommasino M, Sylla BS, Hasan UA. 2010. EBV latent membrane protein 1 is a negative regulator of TLR9. *J. Immunol.* 185:6439–6447. <http://dx.doi.org/10.4049/jimmunol.0903459>.
 170. Shahzad N, Shuda M, Gheit T, Kwun HJ, Cornet I, Saidj D, Zannetti C, Hasan U, Chang Y, Moore PS, Accardi R, Tommasino M. 2013. The T antigen locus of merkel cell polyomavirus downregulates human Toll-like receptor 9 expression. *J. Virol.* 87:13009–13019. <http://dx.doi.org/10.1128/JVI.01786-13>.
 171. Ronco LV, Karpova AY, Vidal M, Howley PM. 1998. Human papillomavirus 16 E6 oncoprotein binds to interferon regulatory factor-3 and inhibits its transcriptional activity. *Genes Dev.* 12:2061–2072. <http://dx.doi.org/10.1101/gad.12.13.2061>.
 172. Li K, Lemon SM. 2013. Innate immune responses in hepatitis C virus infection. *Semin. Immunopathol.* 35:53–72. <http://dx.doi.org/10.1007/s00281-012-0332-x>.
 173. Arzumanyan A, Reis HM, Feitelson MA. 2013. Pathogenic mechanisms in HBV- and HCV-associated hepatocellular carcinoma. *Nat. Rev. Cancer* 13:123–135. <http://dx.doi.org/10.1038/nrc3449>.
 174. Sathish N, Yuan Y. 2011. Evasion and subversion of interferon-mediated antiviral immunity by Kaposi's sarcoma-associated herpesvirus: an overview. *J. Virol.* 85:10934–10944. <http://dx.doi.org/10.1128/JVI.00687-11>.
 175. Lee HR, Brulois K, Wong L, Jung JU. 2012. Modulation of immune system by Kaposi's sarcoma-associated herpesvirus: lessons from viral evasion strategies. *Front. Microbiol.* 3:44. <http://dx.doi.org/10.3389/fmicb.2012.00044>.
 176. Ishido S, Wang C, Lee BS, Cohen GB, Jung JU. 2000. Downregulation of major histocompatibility complex class I molecules by Kaposi's sarcoma-associated herpesvirus K3 and K5 proteins. *J. Virol.* 74:5300–5309. <http://dx.doi.org/10.1128/JVI.74.11.5300-5309.2000>.
 177. Stevenson PG, Efstathiou S, Doherty PC, Lehner PJ. 2000. Inhibition of MHC class I-restricted antigen presentation by gamma 2-herpesviruses. *Proc. Natl. Acad. Sci. U. S. A.* 97:8455–8460. <http://dx.doi.org/10.1073/pnas.150240097>.
 178. Belanger C, Gravel A, Tomoiu A, Janelle ME, Gosselin J, Tremblay MJ, Flamand L. 2001. Human herpesvirus 8 viral FLICE-inhibitory protein inhibits Fas-mediated apoptosis through binding and prevention of procaspase-8 maturation. *J. Hum. Virol.* 4:62–73.
 179. Neurath AR, Strick N. 1990. Antigenic mimicry of an immunoglobulin A epitope by a hepatitis B virus cell attachment site. *Virology* 178:631–634. [http://dx.doi.org/10.1016/0042-6822\(90\)90368-2](http://dx.doi.org/10.1016/0042-6822(90)90368-2).
 180. Locarnini S, Zoulim F. 2010. Molecular genetics of HBV infection. *Antiviral Ther.* 15(Suppl 3):3–14. <http://dx.doi.org/10.3851/IMP1619>.
 181. Rehermann B, Nascimbeni M. 2005. Immunology of hepatitis B virus and hepatitis C virus infection. *Nat. Rev. Immunol.* 5:215–229. <http://dx.doi.org/10.1038/nri1573>.
 182. Brunetto MR, Rodriguez UA, Bonino F. 1999. Hepatitis B virus mutants. *Intervirology* 42:69–80. <http://dx.doi.org/10.1159/000024968>.
 183. Doorbar J. 2013. Latent papillomavirus infections and their regulation. *Curr. Opin. Virol.* 3:416–421. <http://dx.doi.org/10.1016/j.coviro.2013.06.003>.
 184. Gravitt PE. 2012. Evidence and impact of human papillomavirus latency. *Open Virol. J.* 6:198–203. <http://dx.doi.org/10.2174/1874357901206010198>.
 185. Iyer JG, Afanasiev OK, McClurkan C, Paulson K, Nagase K, Jing L, Marshak JO, Dong L, Carter J, Lai I, Farrar E, Byrd D, Galloway D, Yee C, Koelle DM, Nghiem P. 2011. Merkel cell polyomavirus-specific CD8(+) and CD4(+) T-cell responses identified in Merkel cell carcinomas and blood. *Clin. Cancer Res.* 17:6671–6680. <http://dx.doi.org/10.1158/1078-0432.CCR-11-1513>.
 186. Perez-Liz G, Del Valle L, Gentilella A, Croul S, Khalili K. 2008. Detection of JC virus DNA fragments but not proteins in normal brain tissue. *Ann. Neurol.* 64:379–387. <http://dx.doi.org/10.1002/ana.21443>.
 187. Soderberg-Naucler C, Johnsen JI. 2012. Cytomegalovirus infection in brain tumors: a potential new target for therapy? *Oncoimmunology* 1:739–740. <http://dx.doi.org/10.4161/onci.19441>.
 188. Cobbs CS, Harkins L, Samanta M, Gillespie GY, Bharara S, King PH, Nabors LB, Cobbs CG, Britt WJ. 2002. Human cytomegalovirus infection and expression in human malignant glioma. *Cancer Res.* 62:3347–3350.
 189. Baryawno N, Rahbar A, Wolmer-Solberg N, Taher C, Odeberg J, Darabi A, Khan Z, Sveinbjornsson B, FuskevAg OM, Segerstrom L, Nordenskjold M, Siesjo P, Kogner P, Johnsen JI, Soderberg-Naucler C. 2011. Detection of human cytomegalovirus in medulloblastomas reveals a potential therapeutic target. *J. Clin. Invest.* 121:4043–4055. <http://dx.doi.org/10.1172/JCI57147>.
 190. Soroceanu L, Cobbs CS. 2011. Is HCMV a tumor promoter? *Virus Res.* 157:193–203. <http://dx.doi.org/10.1016/j.virusres.2010.10.026>.

Martyn K. White, M.A., D.Phil. (Oxon), is an Assistant Professor in the Department of Neuroscience, Temple University School of Medicine, Philadelphia, PA, USA. He received both his M.A. in biochemistry and D.Phil. in cell biology in 1982 from the University of Oxford, United Kingdom. After postdoctoral training at the University of Virginia, Charlottesville, VA, he has held faculty positions at East Carolina University, Greenville, NC, and Thomas Jefferson University, Philadelphia, as well as Temple University. Dr. White has published more than 100 peer-reviewed scientific papers and several book chapters and was managing and commissioning editor for two books. His areas of interest include the cell biology of malignant transformation and the molecular mechanisms employed by tumor viruses such as the retrovirus Rous sarcoma virus, the simian polyomavirus SV40, and the human polyomaviruses BKV and JCV.



Joseph S. Pagano received his M.D. at Yale University, residency training at the Peter Bent Brigham Hospital, Boston, and research training at The Wistar Institute and The University of Pennsylvania, Philadelphia, and The Karolinska Institute, Stockholm. He has been a member of the faculty of The University of North Carolina School of Medicine since 1965 and was Founder and Director of the UNC Lineberger Comprehensive Cancer Center. He is currently Lineberger Professor of Cancer Research and Professor of Medicine, Microbiology & Immunology. He is scientific advisor to cancer centers and research institutes and executive member of the Board of Directors of The Hamner Institutes for Health Sciences. A member of the National Academy of Medicine, he is a tumor virologist whose research with Epstein-Barr virus uncovered the episomal form of the viral genome used in latent EBV infection, and he later discovered IRF-7. His current research focuses on viral and cellular deubiquitinating enzymes.



Kamel Khalili received his Ph.D. in microbiology from the University of Pennsylvania in 1983. Dr. Khalili joined the faculty of Jefferson Medical College in 1987 as an Assistant Professor. From 1996 to 1999, Dr. Khalili was Professor and Director of the Center for Neurovirology and Neuro-oncology at Drexel University College of Medicine. In 1999, Dr. Khalili established the Center for Neurovirology and Cancer Biology at Temple University College of Science and Technology. Since 2005, he has been the Laura H. Carnell Professor and Founding Chair of the Department of Neuroscience at Temple University School of Medicine. Dr. Khalili has been studying polyomaviruses and their role in the pathogenesis of human cancers for more than 30 years. He has authored more than 370 manuscripts, edited two textbooks entitled *Human Polyomaviruses: Molecular and Clinical Perspectives* and *Viral Oncology: Basic Science and Clinical Applications*, and authored several other book chapters on various related subjects.

