

Yashica 230-AF

Posted 9-1-'02

This camera manual library is for reference and historical purposes, all rights reserved.

This page is copyright by mike@butkus.org, M. Butkus, NJ.

This page may not be sold or distributed without the expressed permission of the producer
I have no connection with Yashica Co., Japan

On-line camera manual library
This is the full text and images from the manual.

**If you find this manual useful, how about a donation of \$3 to:
M. Butkus, 29 Lake Ave., High Bridge, NJ 08829-1701
and send your e-mail address so I can thank you.
Most other places would charge you \$7.50 for a electronic copy
or \$18.00 for a hard to read Xerox copy.**

**This will help me to continue to host this site, buy new manuals, and pay their shipping costs.
It'll make you feel better, won't it?
If you use Pay Pal, use the link below. Use the above address for a check, M.O. or cash.
www.PayPal.me/butkus**



www.PayPal.me/butkus

[Back to main camera manual page](#)



Thank you for your purchase of a Yashica 230-AF. This is a highly developed auto-focus SLR camera with many outstanding features. It is designed to work in perfect harmony with its dedicated flash. This camera features three auto-focus modes: normal auto-focus, continuous auto-focus and trap focus. These sophisticated focusing modes, in combination with various exposure modes such as programmed auto mode, will enable you to open up new picture-taking possibilities. It also provides an AE lock system based on the spot metering method, a large-size display panel for centralized information control and many other features that have been developed with latest technology. Before you use the camera, please read this manual carefully. It will assure you a longer service with proper care....

The descriptions in this manual are made with a Yashica AF lens 50 mm F1.8 on the camera. The operating procedure is the same with other Yashica AF lenses, too.

Names of Parts	8	Camera Functions and Applications in Detail	55
Mounting and Dismounting the Dedicated Flash CS-11 AF	16	Display of Shutter Speed and Aperture	56
Basic Operation	19	Using the Focus Lock	58
Mounting the Lens	20	Focusing Screen	62
Loading the Battery	20	Program Control Diagram	64
Main Switch	22	Automatic Exposure Compensation in the AS Mode	68
Loading the Film	24	Resetting the Mode	68
Taking Pictures	28	Bulb Exposure	70
Shutter Release	46	Using the Self-timer	72
Electronic Signal Button	46	Trap Focus Shooting	76
Using the Flash CS-110AF.....	48	Metering System	81
Rewinding the Film	52	Taking Pictures on Spot Metering	86

- (1) Program Reset Button
- (2) Operating Lever
- (3) Display Panel
- (4) Light Receptor Window
- (5) Accessory Shoe
- (6) Flash Contacts
- (7) Direct X-contact
- (8) Main Switch
- (9) Exposure Compensation Button
- (10) Focus Mode Button
- (11) Exposure Mode Button
- (12) Drive Mode Button
- (13) Battery Holder Screw
- (14) Battery Holder
- (15) Shutter Release
- (16) Self-timer LED
- (17) Power Terminal for Flash



- (18) Lens Mounting Index
- (19) AF/MF Selector Lever
- (20) Lens Release Button
- (21) AF Lock/F-Number Button
- (22) Electronic Signal Button
- (23) ISO Button

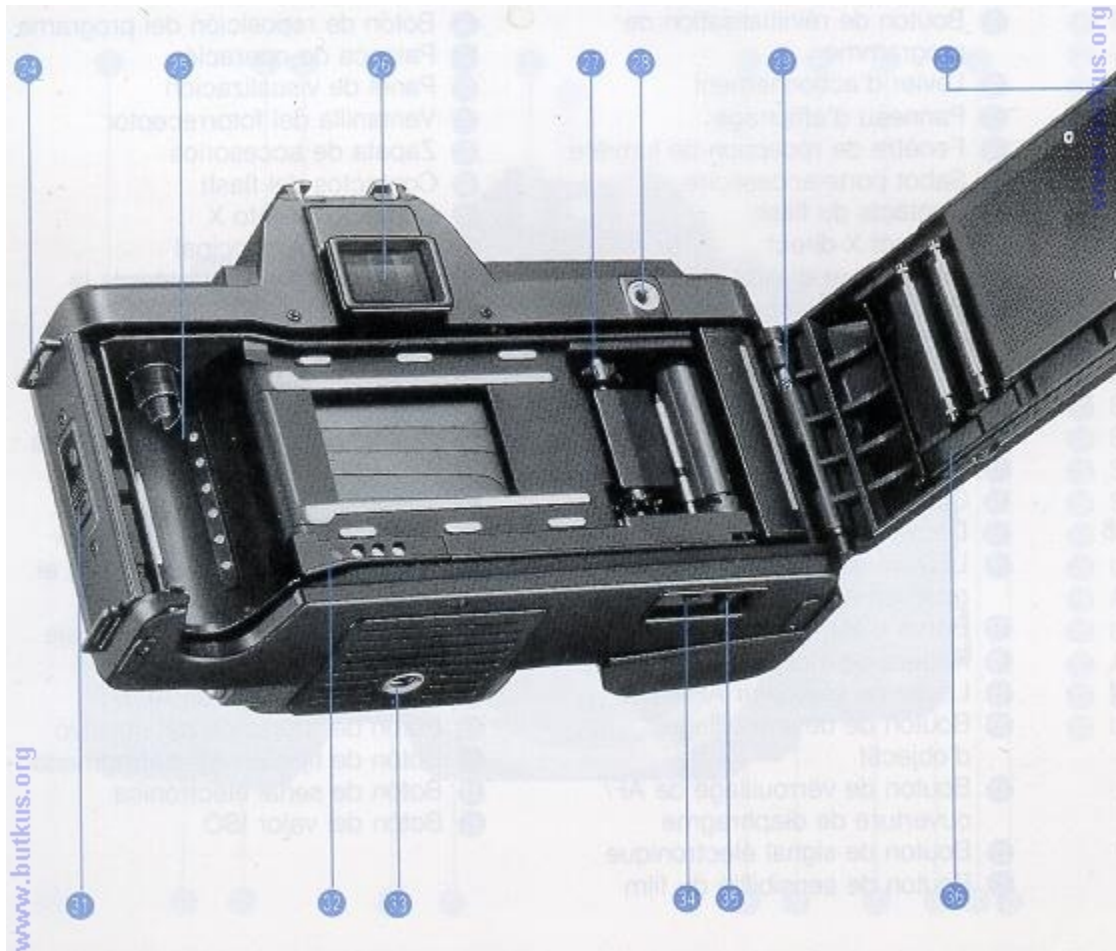

(24) Strap Lug

(25) DX Contacts

(26) Viewfinder Eyepiece

(27) Sprocket

(28) Release Socket

(29) Camera Back Release Pin

(30) Film Check Window

(31) Camera Back Lock

(32) Data Back Contacts

(33) Tripod Socket

(34) Rewind Release Button

(35) Film Rewind Switch

(36) Camera Back

< Display Panel >



The display panel shows all information available for taking pictures with this camera. It may not represent actual data,

- | | |
|-------------------------------------|---|
| (1) Film Speed (ISO) | (12) Aperture-priority Mode Indicator |
| (2) Shutter-priority Mode Indicator | (13) Electronic Signal Indicator |
| (3) Program Mode Indicator | (14) Aperture/Exposure Compensation Setting |
| (4) Flash Mark | (15) Battery Check Mark |
| (5) Exposure Counter | (16) Over/Underexposure Mark |
| (6) Film Transport/Rewind Mark | (17) Trap Focus Mark |
| (7) Exposure Compensation Mark | (18) Manual Focus Indicator |
| (8) Continuous Shooting Indicator | (19) Auto Focus Indicator |
| (9) Single-frame Shooting Indicator | (20) Continuous Auto Focus Indicator |
| (10) Self timer Mark | (21) Shutter Speed/Film Speed |
| (11) Manual Mode Indicator | |

< Display in the Viewfinder >

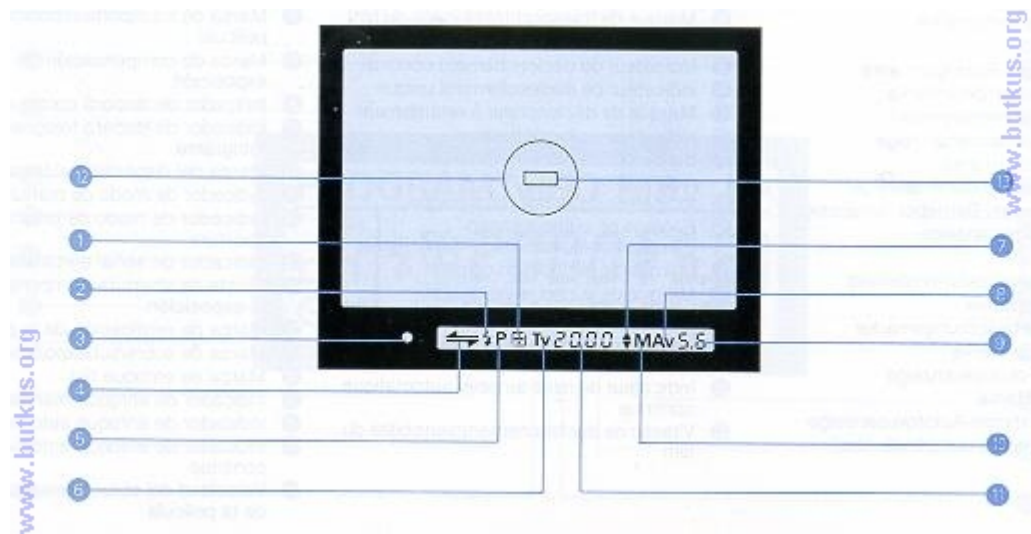

The liquid display section in the viewfinder will automatically brighten up when the light is dim to let you see the display clearly even in the dark.

- (1) Exposure Compensation Mark
- (2) Flash Mark
- (3) Sharp Focus LED (green)
- (4) Front M is-focus/Rear M is-focus Mark
- (5) Program Mode Indicator
- (6) Shutter-priority Mode Indicator
- (7) Over/Underexposure Mark
- (8) Aperture priority Mode Indicator
- (9) Aperture/Exposure Compensation Setting
- (10) Manual Mode Indicator
- (11) Shutter Speed/Film Speed
- (12) Spot Circle
- (13) Focusing Frame

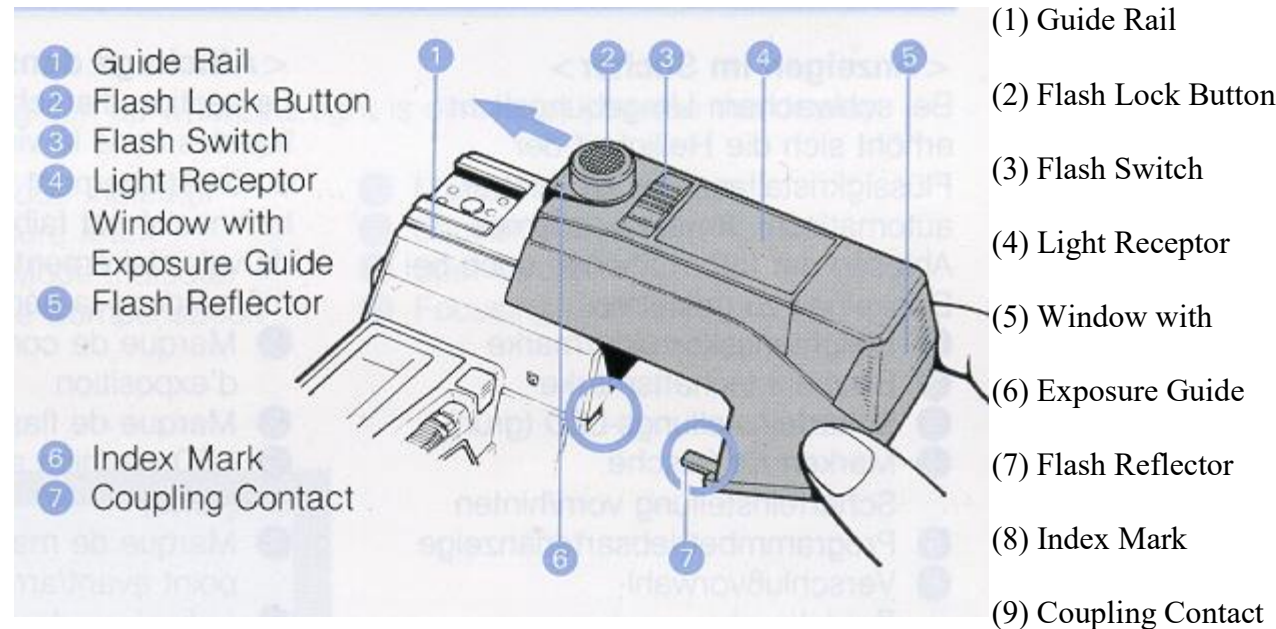
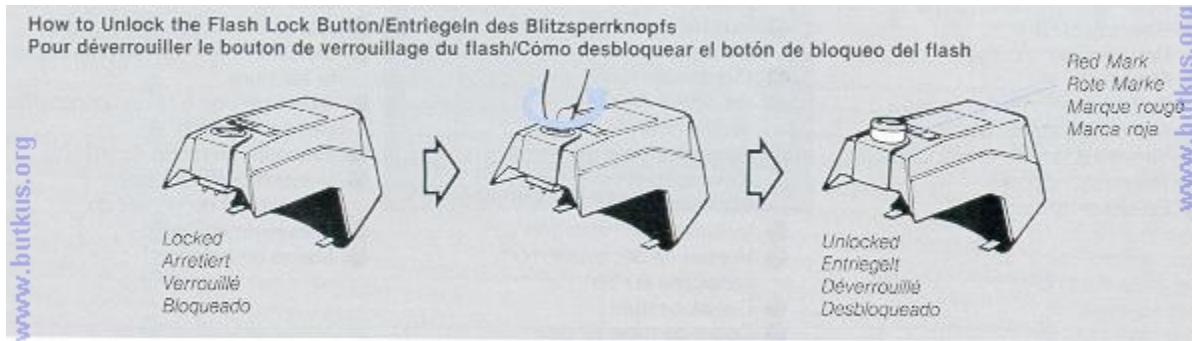

< **Mounting and Dismounting the Dedicated Flash CS110AF** > To mount the flash, first unlock the Flash Lock Button. (When it is unlocked, it will pop up and show a red mark.) Mount the flash from the front side of the camera and slide it in along the Guide Rail as far as it will go. Then, press down the Flash Lock Button and turn it clockwise until the index mark on it comes opposite the index mark on the flash, and lock the flash in place. To dismount the flash, repeat the above-mentioned procedure in reverse.

* Do not apply too much pressure on the flash coupling contact.---

* When attaching the flash, make sure the Coupling Contact is inserted into the camera's Power Terminal.

Attaching the Strap

Attach the Strap as shown in the illustration.

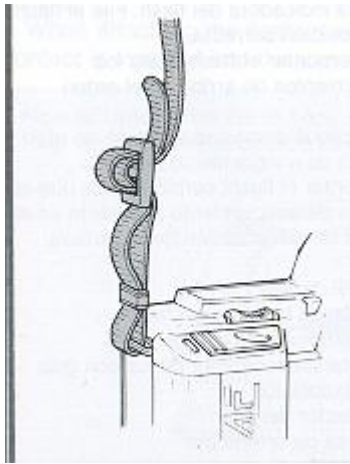

Attaching the Eyecup Attach the Eyecup as shown in the illustration.

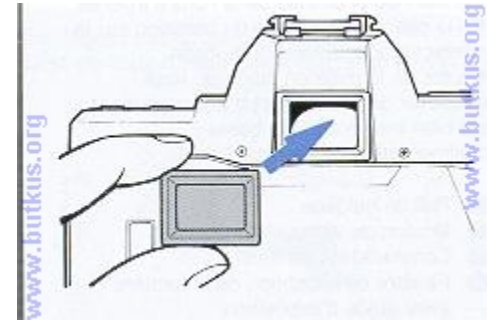

Attach the optional FL type Diopter Lenses as shown. The Eyecup can be attached on a Diopter Lens.

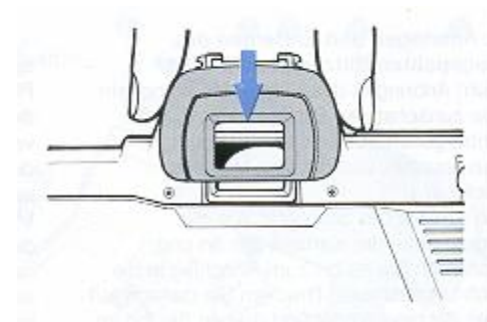

Mounting the Lens

First, remove the lens cap and body cap. Then, align the red dot on the lens rear with the red dot (lens mounting index) on the camera's Lens Release Button, push in the lens and turn it clockwise until it locks with a click.

- * To dismount it, press in the Lens Release Button and turn it counterclockwise.
- * If you are changing the lens with film loaded in the camera, take care to avoid direct sunlight.

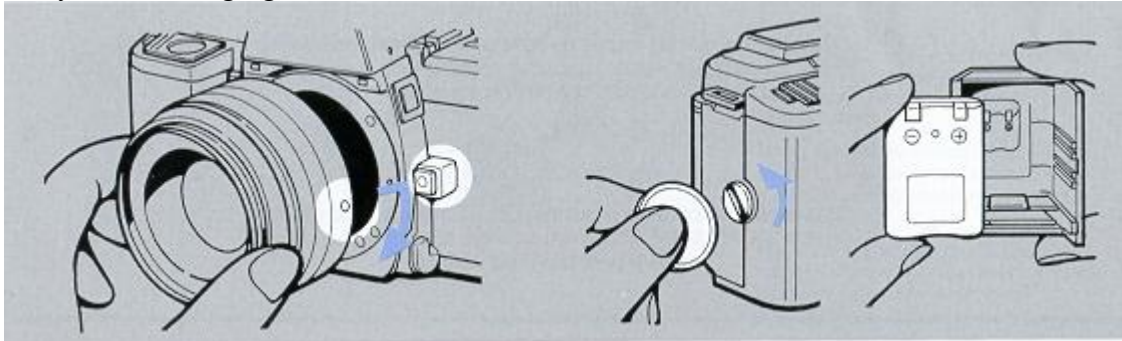

Loading the Battery

Loosen the Battery Holder Screw by turning it toward the arrow with a coin and remove the Battery Holder. Insert the lithium battery correctly, as illustrated inside the holder. Then, close the holder so that the claw on its side is engaged, install it again and lock it in place with the screw.

Use a 6 V Lithium battery (2CR5)

Main Switch

The Main Switch of this camera has three positions. When it is set to LOCK, the camera is turned off. When it is set to AK-L, you can take pictures with a fixed exposure value on spot metering. When it is set to ON you can take pictures by measuring exposure on center-weighted metering. Set the switch depending on the subject you want to shoot. If you are not using the camera, always set it to LOCK.

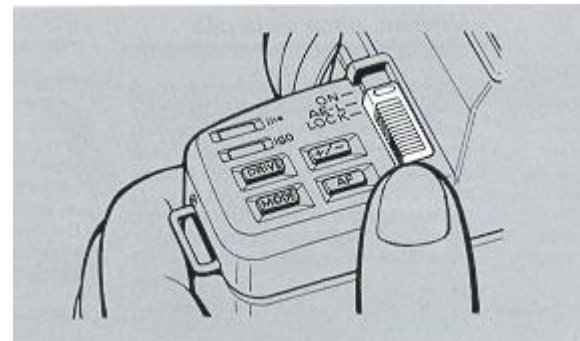

LOCK The camera is turned off.

AE-L The camera is turned on and takes pictures on spot metering. If the Shutter Release is depressed halfway, the AE lock is activated.

ON The camera is turned on and takes pictures on center-weighted metering. Normally, set the Main Switch to ON.

* When the camera is turned on, the shutter speed, aperture and other information will be displayed for 8 seconds in the display panel and viewfinder.

Loading the Film

1. Set the Main Switch to ON, open the Camera Back and load the film. To open the Camera Back, push down the Camera Back Lock while pressing in the button on it. To insert the film, first fit the recessed end of the cassette to the shaft located on top of the film chamber and push it in. It will thus fit smoothly into position. Always load and unload film in subdued light.

* If you use DX-coded film, the camera will automatically set itself for the speed of the film loaded in it.

* Do not touch the shutter curtain and DX contacts.

Insert the film tip as far as the orange mark ("--") and close the Camera Back. Engage the film perforations with the sprocket teeth and make sure the film lies flat and tight as shown in the illustration, then close the Camera Back. As soon as you close it, the film will automatically advance to the first frame.

· If the film is advancing properly, the Exposure Counter will show "1" and the Film Transport Mark "⊙—" will turn on in the display panel. You are now ready to take pictures. If the Exposure Counter does not move from "0" and blinks, or if the mark "⊙—" does not turn on, the film is not advancing properly. Open the Camera Back and load the film correctly again.

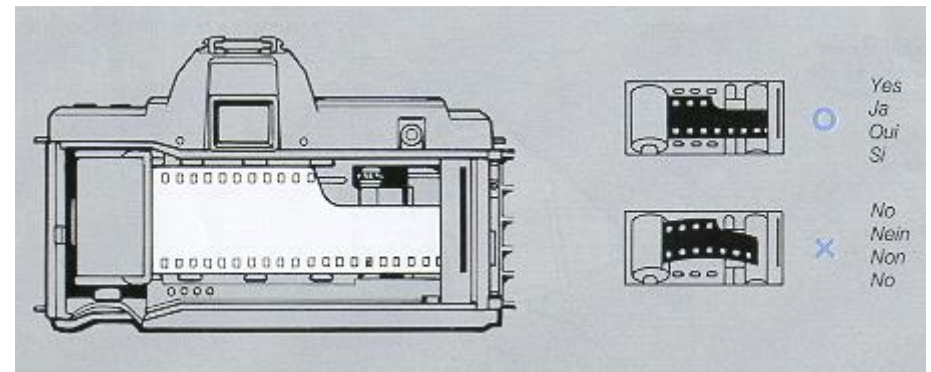
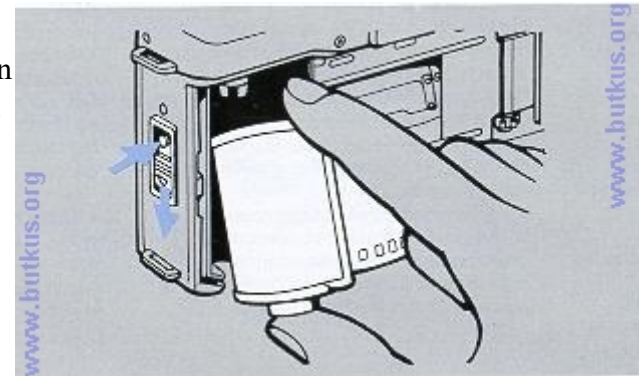

Taking Pictures

Before taking pictures, set the drive mode, focusing mode and exposure mode to the desired positions according to the subject you want to shoot.

To set the mode, move the Operating Lever to the left or right while pressing the corresponding mode button until the desired mode appears in the display panel.

* The display in the panel will run through quickly if you continue to push the lever for more than a second...

* The Program Reset Button is very useful because the camera will automatically set the positions of the drive mode, focusing mode and exposure mode that are most convenient for taking pictures as soon as you press this button.

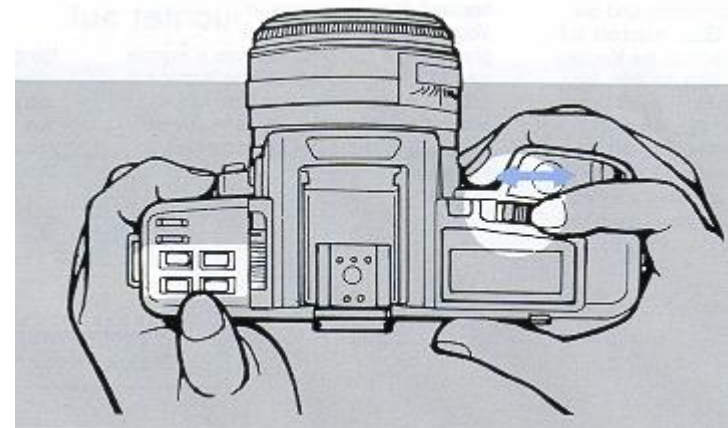

< Mode description >

* **Drive modes** There are three modes: single-frame shooting (S) continuous shooting (C), and self-timer shooting (),

* **Focusing modes** There are four modes: auto-focus (AF), continuous autofocus (CAF), trap focus (), and manual focus (M).

* **Exposure modes** There are four modes: programmed auto exposure (PROGRAM), shutter-priority auto exposure (TV), aperture priority auto exposure (AV), and manual exposure (M).

< Drive Modes >

Operating Lever to the right

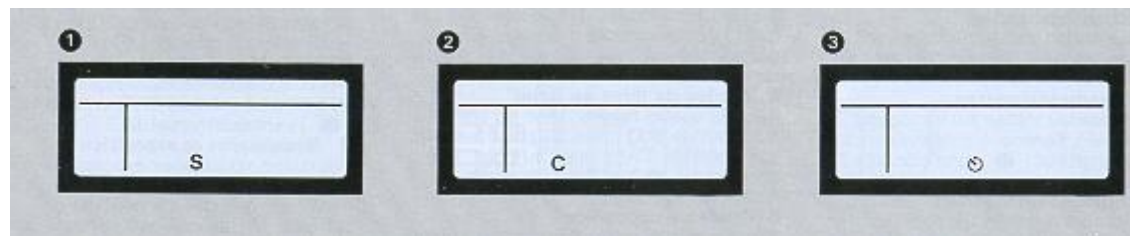
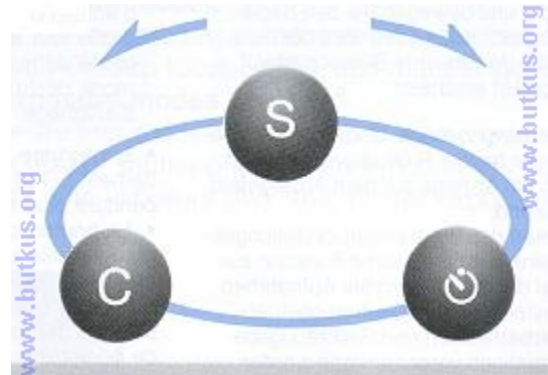

- (1) **Single Frame Shooting:** S Each time you depress the Shutter Release, the camera will expose one frame at a time and advance the film to the next frame, then stop.
- (2) **Continuous Shooting:** C While you are depressing the Shutter Release, the camera will take pictures one after another at a rate of up to about 1.8 frames a second.
- (3) **Self timer Shooting:** \$) When you depress the Shutter Release, the self-timer LED in the camera front will turn on and the shutter will trip after 10 seconds.

<Focusing Modes>

This camera offers a versatile focusing system which consists of four focusing modes. The auto-focus mode (AF) is convenient for taking ordinary pictures. The continuous auto-focus mode (CAF) allows you to take pictures in succession by keeping your subject in sharp focus as it moves. The trap focus mode  is designed to trip the shutter as soon as the lens is focused on the subject if you have set it to an intended subject distance in advance. You can also focus the lens manually (MF).

Selector Lever

This lever selects the basic focusing functions of the camera. If you want to take auto-focus or continuous auto focus pictures, set the lever to "AF". If you want to take trap focus or manual-focus pictures, set it to "MF".

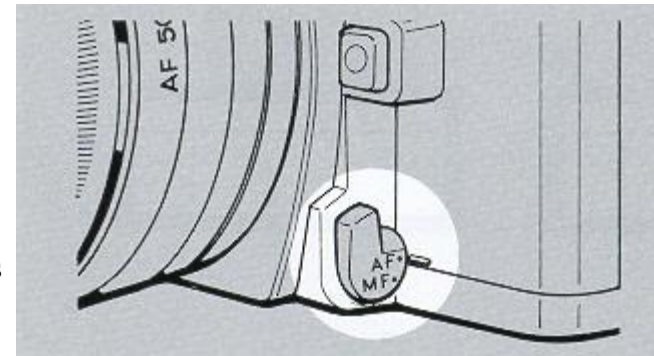

Selector Lever at AF



Selector Lever at MF



Auto Focus: AF

If you depress the Shutter Release lightly the camera will automatically start to focus the lens on the subject located in the focusing frame in the viewfinder. As soon as the green sharp-focus LED turns on, you can depress the Shutter Release all the way to take your picture. This mode is convenient for taking relatively static objects, because the focus is locked when the lens is focused on the subject by depressing the Shutter Release halfway.

· If you take auto-focus pictures in the drive mode "C" the camera will automatically focus the lens for each frame and take pictures continuously.

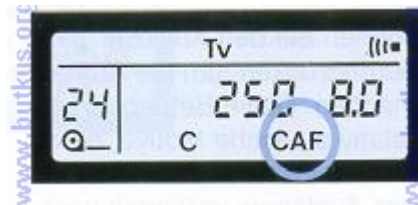
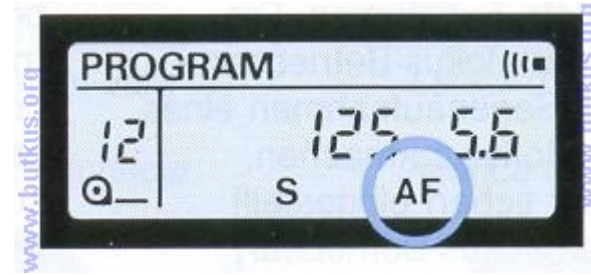

Continuous Auto Focus: CAF As long as you keep depressing the Shutter Release lightly, the auto-focusing system will function and keep the subject in the focusing frame in sharp focus. This mode is useful for shooting moving subjects continuously, because it will continue to



focus on the subject as the subject moves and its shooting distance changes, even after the lens has been once focused on it. Depress the Shutter Release all the way when the sharp-focus LED turns on.

- If you take continuous auto-focus pictures in the drive mode "C", the camera will automatically focus the lens on the subject and take pictures continuously with the fixed focus.
- Use the AF Lock Button to lock the focus.

Trap Focus:



This mode is useful for shooting nervous animals or moving subjects at a fixed distance. Face the camera toward the place where you guess your subject will come, set the camera to that distance with the Focusing Ring, attach the cable switch and release it. As soon as the subject comes to this distance and it is caught in the focusing frame in the center of the viewfinder, the shutter will trip to take your picture.

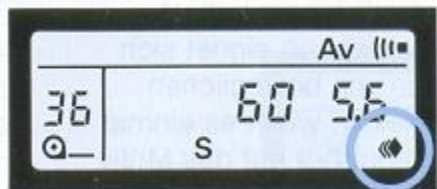



Manual Focus: MF To focus, turn the Focusing Ring with your hand. If the subject is not correctly focused, the front mix-focus or rear mix-focus mark will turn on. If it is in sharp focus, the green LED will turn on...



: Front Mis-focus Mark. \ The lens is focused in front of the subject.

_ : Rear Mis-focus Mark. The lens is focused behind the subject.

--is: "Focusing impossible" Mark (blinks)

<Exposure Modes>

(1) Programmed Auto Exposure: PROGRAM The camera contains a combination program of **shutter** speeds and apertures and automatically selects the optimum combination of shutter speed and aperture depending on the brightness of the subject

(2) Shutter priority Auto Exposure: TV If you set a shutter speed, the camera will automatically, select the optimum aperture for it depending on the brightness of the subject, to provide correct exposure.

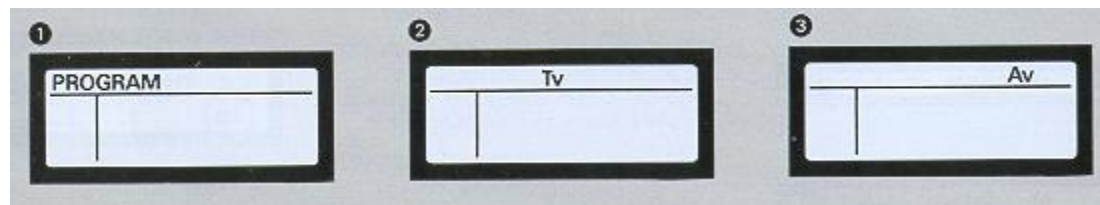

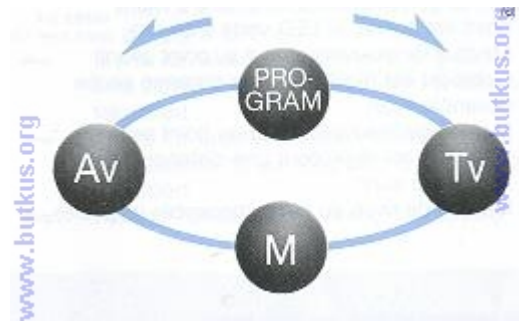

Operating Lever to the left

Operating Lever to the right

* The shutter speed is set with the Operating Lever.

(3) Aperture-priority Auto Exposure: Av If you set an aperture, the camera will automatically control the shutter speed to provide correct exposure.

* The aperture is set with the Operating Lever.

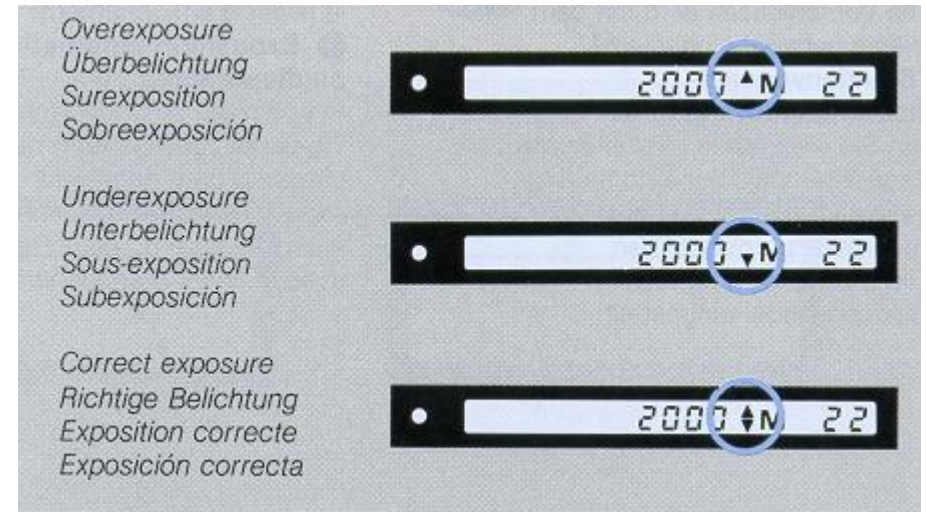
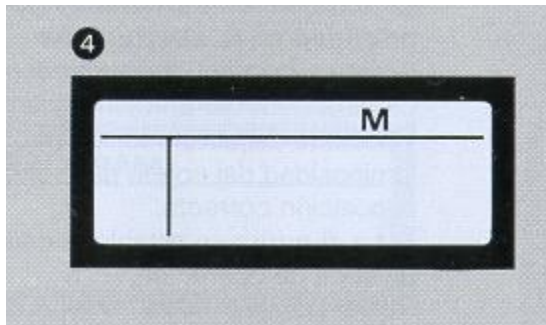

4. Manual Exposure: M In this mode, you can set your desired shutter speed and aperture by hand.

· The shutter speed is set with the Operating Lever, and the aperture is set with this lever while pressing in the F-number Button.

Overexposure/Underexposure Warning If you depress the Shutter Release lightly, you may see an Overexposure ("▲") or Underexposure ("▼") turn on in the viewfinder. If the mark "▲" appears, your subject will be overexposed relative to the correct exposure measured by the camera; if the mark "▼" appears, your subject will be underexposed. To obtain correct exposure change the aperture or shutter speed so that the mark "◀▶" appears, then shoot.

· If you use an AF Converter (optional accessory), take pictures in the "Av" or "M" mode. Even if the camera is set to other exposure modes, it will operate in the "Av" mode.

Shutter Release

If the Shutter Release is depressed halfway, the lens is driven to focus itself (when the Selector Lever is set at "AF") and the shooting information at that time is shown in the viewfinder and display panel. It will stay for 8 seconds after the finger is released, and turn off. Then, depress the Shutter Release all the way to take your picture.

Electronic Signal Button

When the mark "⏏" shows in the display panel, you will hear an audible electronic signal in the following cases:

- * When the lens is focused on the subject (in the AF and "◀▶" modes);
- * When the entire roll of film has been exposed;
- * When the self-timer is operating.

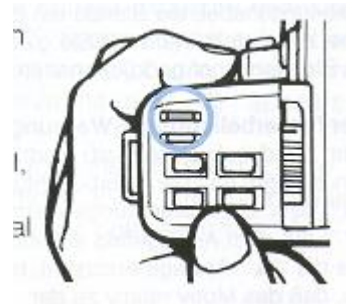

To turn off the audible signal, turn off the mark "⏏" by pressing the Electronic Signal Button.

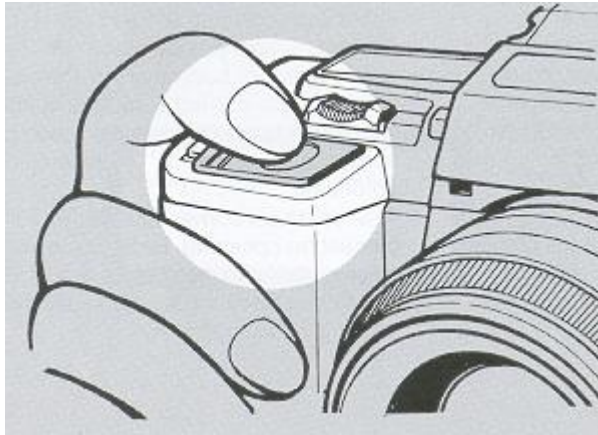

Using the Flash CS- 110AF

1. Mount the Flash

Mount the flash on the camera as described on page 16.

2. Turn on the flash's main switch.

When it is turned on, the power for the flash is supplied from the camera.

As soon as the flash is fully charged, the flash mark "  " will turn on in the display panel and viewfinder.

* Charging the flash is possible while the display in the viewfinder and display panel turns on.

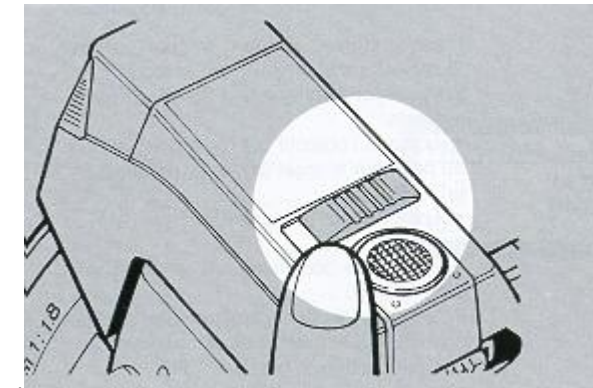

The dedicated small-size flash CS-1 10AF can be integrated with the camera to let you take beautifully exposed pictures at night or even in backlight with ease

3. After making sure the mark "⚡" turns on, depress the Shutter Release to take your flash picture.

As soon as the flash has fired, the entire liquid crystal display in the viewfinder will illuminate in orange color to let you see that the flash has surely fired while you take pictures.

If you are taking auto exposure pictures with the CS-1 10AF, the shutter speed is automatically set to 1/90 sec. If you are working in the manual exposure mode, the shutter will trip with the shutter speed you have set if it is 1/90 sec. or slower.

If the CS-110AF is attached or detached with some types of lenses mounted on the camera (AF Zoom Lens 28-85 mm F3.5-4.5, for example), it may knock against the lens. In this case, dismount the lens before attaching or detaching the flash.

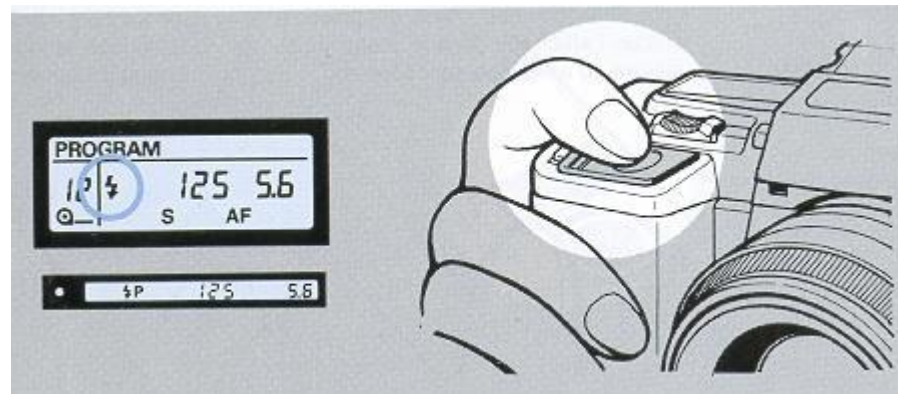

Rewinding the Film

If the entire roll of film has been exposed, the camera will stop winding the film and the Exposure Counter in the display panel will blink.

1. While pressing the Rewind Release Button, slide the Rewind

Switch toward "◀". The Film Rewind Mark "⏪" will show in the display panel and the film will start rewinding. While it is rewinding, the Exposure Counter will continue to show the last number of frame that was displayed when you finished shooting.

* If rewinding has started, remove your finger from the Rewind Switch.

2. If rewinding is completed, unload the film.

If the film has been completely wound back into its cassette, the rewind motor will automatically stop and the Exposure Counter's number "0" and the mark "⏪" will blink in the display panel.

· Unload the film in subdued light and take the exposed film for processing as soon as possible.

· After unloading the film, be sure to set the Main Switch at LOCK .

* You can also rewind the film in the middle of a roll. But you will need a special tool to remove the film end from the cartridge and try to use the same roll again by making blank (in manual mode – hand over lens) shots two frames past your last exposure (that you must remember).

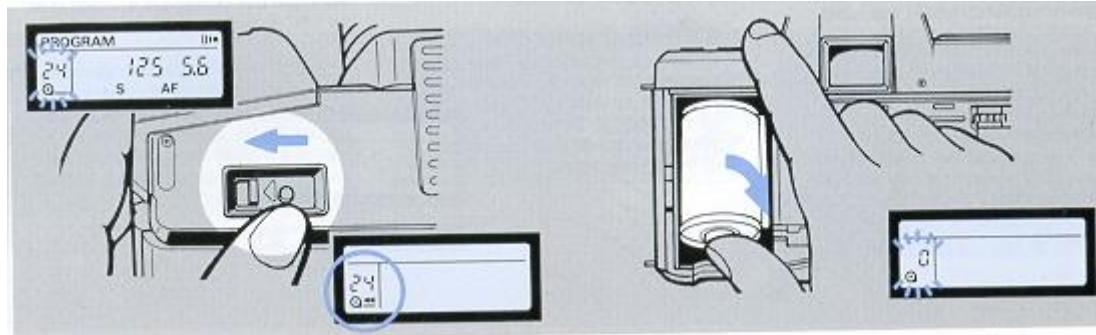

CAMERA FUNCTIONS IN DETAIL

This chapter explains the camera functions and applications of the Yashica 230-AF in detail.

Display of Shutter Speed and Aperture

The display of shutter speed and aperture in the display panel and viewfinder will turn on in the following cases:

- When the Main Switch is turned on;
- When the Shutter Release is depressed halfway;
- When a mode Button (Focus Mode Button, Drive Mode Button etc.) is pressed. The display will appear for eight seconds, then automatically turn off to save battery. However, the shutter speed and aperture you have set will be stored in memory. The shutter speeds are displayed in 1/2-step

increments from "2000" (1/2000 sec.) to "16" (16 sec.), and the apertures in 1/2-step increments within the aperture range of the lens used. If the picture is taken with an intermediate value between neighboring 1/2 steps, the camera will display the exposure value that is most close to the value which is set. For example, if you are using an F1.8 lens, the camera will show "1.7" if you are using an F3.3 lens, it will show "3.5".

- In the manual-exposure and shutter-priority auto exposure modes the shutter speeds can be set in 1-step increments, and the apertures in 1/2-step increments. Intermediate setting is impossible.
- If the exposure mode is "PROGRAM", "Tv" or "Av", the lens' smallest-aperture value will blink when the subject is overexposed relative to the correct exposure measured by the camera; and the maximum-aperture value will blink if it is underexposed.

Using the Focus Lock

If you are taking auto-focus pictures and the subject you want to focus is not located in the center of the viewfinder, or if the subject is difficult to focus in the situations mentioned below, use the focus lock...

1. First, aim the Focusing Frame at your subject and focus. If the Shutter Release is depressed halfway, the lens will start focusing itself. As soon as it is focused on the subject, the green LED will turn on to tell you that focusing has been completed.

2. Lock the focus, recompose your picture and shoot.

* If you are shooting in the "AF" mode, the focus will remain locked while the subject is in sharp focus and the Shutter Release is depressed halfway.

* If you are shooting in the "CAF" mode, lock the focus by pressing the AF Lock Button when the subject is focused.
(The focus will remain locked as long as you keep your finger on the AF Lock Button.)

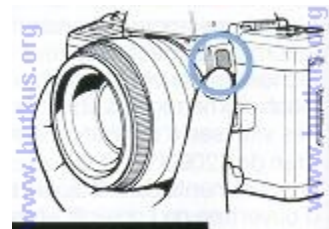

<Subjects that are Difficult to Focus>

In the following cases, the auto-focus system will not function properly and the "Focusing Impossible" mark "=" will blink in the viewfinder. In such cases, focus the lens on another object located nearly the same distance as the subject, activate the focus lock and shoot. You can also focus the lens manually.

- (1) When the subject is too bright or too dark;
- (2) When the subject contrast is extremely low;
- (3) When there is a strong light source in or around the Focusing Frame;
- (4) When there are two or more subjects at extremely different distances in the Focusing Frame;
- (5) When the subject has a uniform pattern such as vertical stripes
- (6) Fast moving subjects;
- (7) When the subject has no concrete form, such as flame or smoke;
- (8) When the quantity of light from the subject is extremely reduced by an ND filter or polarizing filter...

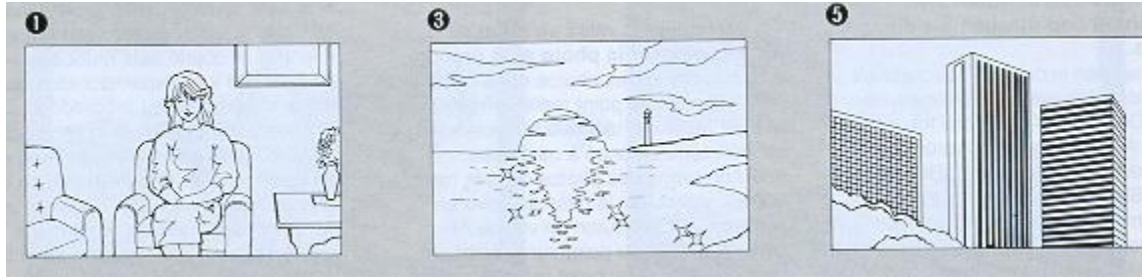

Focusing Screen

< Focusing Frame and Spot Circle >

The Focusing Screen has a Focusing Frame for auto focusing and a Spot Circle for determining the metering range for spot metering. In addition to this standard focusing screen, three optional screens are available: matte screen for the Data Back, sectioned matte screen, and horizontal split-image/micropism collar screen. They are interchangeable depending on your purpose.

< **Manual Focusing** > You can focus the lens manually on the matte screen with the aid of the Front Mis-focus/Rear Mis-focus Mark in the viewfinder. While looking through the viewfinder, turn the Focusing Ring until the image on the matte screen appears sharp. It will look blurred if the subject is not in sharp focus.

· If you are far- or near-sighted, use FL type Diopter Lenses (optional). Eight different lenses are available: - 5, -4, -3, -2,0, +1, +2,and +3diopters.



Program Control Diagram

This program control diagram shows the control range of shutter speeds and apertures relative to EV values in the programmed auto exposure mode. The program lines mark the available ranges for wide angle, normal and telephoto lenses, and these ranges are automatically set according to the focal length of the lens used. The camera automatically chooses the optimum combination of shutter speed and aperture within the respective program lines. However, you can also change the exposure within the range of the same EV value by shifting the program lines by up to +3 steps. If the correct exposure that is set by the camera is F4, 1/125 sec., and you want to shoot with a shutter speed of 1/60 sec., for example, shift the Operating Lever to the left by 2 steps. Thus, an exposure value of F5.6, 1/60 sec. will be displayed and you can take a correctly exposed picture with the same EV value.

- When the program is shifted, the program indicator will blink. After the picture is taken with the shifted program or after the Main Switch is set to LOCK, the camera will automatically reset the exposure value that was set before the program was shifted.

Program Control Diagram (ISO 100)
 Programmsteuerungs-Diagramm (ISO 100)
 Diagramme de contrôle de programme (ISO 100)
 Diagrama de control programado (100 ISO)

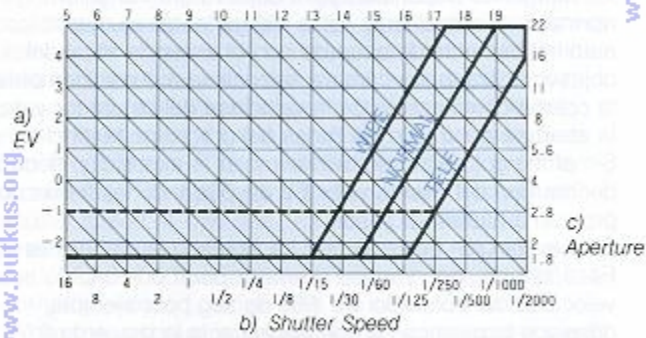

www.butkus.org

Program Shift Diagram (ISO 100)
 Programmverschiebungs-Diagramm (ISO 100)
 Diagramme de décalage de programme (ISO 100)
 Diagrama de cambio de programa (100 ISO)

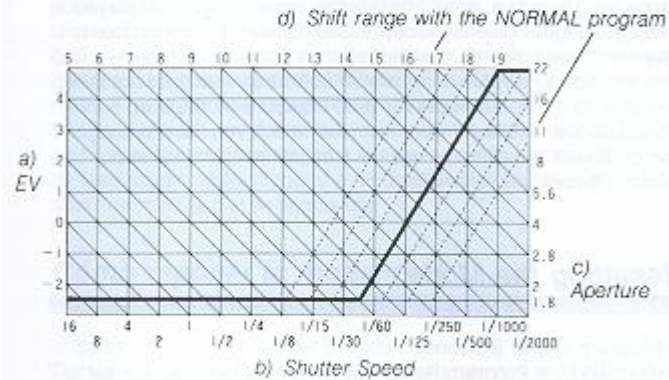

WIDE program line: For lenses with focal lengths shorter than 35 mm

NORMAL program line: For lenses with focal lengths of 35--85 mm

TELE program line: For lenses with focal lengths longer than 85 mm

· This diagram shows the automatic control range with an F1.8 lens. In the case of lenses with different F numbers, the control range becomes narrower as the lens speed decreases. The control range with an F2.8 lens, for example, is represented by the dotted line in the diagram.

Automatic Exposure Compensation in the Mode

If the camera cannot provide a correct aperture for the shutter speed you have set in the shutter-priority auto exposure mode, it will automatically choose again a shutter speed as close as possible to that which you have set so as to provide correct exposure. Therefore even if the shutter speed which is displayed when the Shutter Release is depressed halfway is different from that which you have set, you can go ahead and shoot if the smallest-aperture value or maximum-aperture value does not blink. Likewise, in the aperture-priority auto exposure mode, even if the displayed aperture is different from that which you have set, you can go ahead and shoot unless the smallest-aperture value or maximum-aperture value blinks...

Resetting the Mode

< Program Reset Button >

If you press the **Program Reset Button**, the modes that are set and their display will reset to their initial settings as follows:

· Drive mode	Initial Setting:
· Focusing mode	To "S"
Selector Lever at "AF"	To "AF"
Selector Lever at "MF"	To "MF"
· Exposure mode	To "PROGRAM" ("P" is displayed in the viewfinder)
· Exposure compensation	To "0.0"
· Audible electronic signal	To " (■) "

Bulb Exposure

If you are taking pictures of the sky at night or other subjects requiring long exposure times, use bulb exposure. First, set the exposure mode to "M" and set the shutter speed to "bulb". As long as the Shutter Release is held depressed, the shutter will remain open to expose the subject. For bulb exposure, the camera must be fixed on a tripod or a solid base to prevent camera shake. The shutter is tripped with an optional cable switch connected to the camera.



When the Shutter Release is depressed, the Exposure Counter shows "0" and, while the button is held depressed, it shows the exposure time in seconds. The counter will advance from "0" to "59" and, if the exposure time exceeds 60 seconds, it will return to "1" and count again.

- You cannot use the self-timer and trap focus technique for bulb exposure.



Using the self-timer

If you are shooting group pictures or if you want to include yourself in a souvenir picture, use the self-timer.

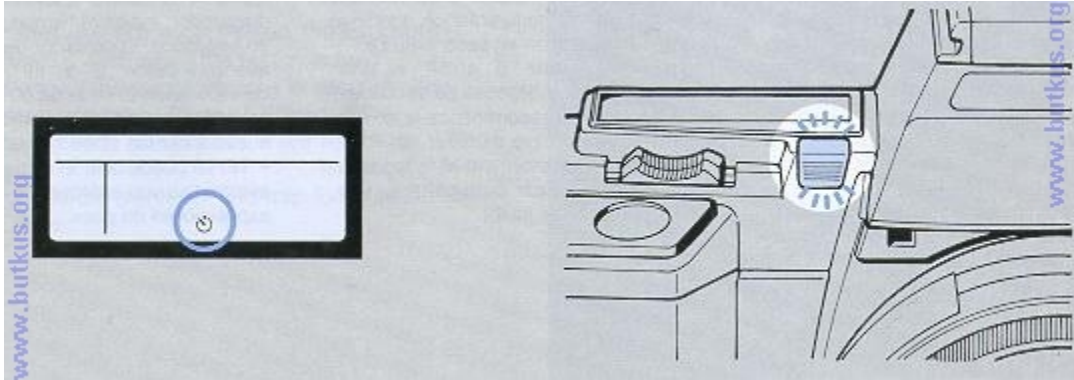

1 Set the Self-timer Mode

While pressing the Drive Mode Button, operate the Operating Lever to show the mark "  " in the display panel.

2 Focus the lens and depress the Shutter Release to start the self-timer. Always depress the Shutter Release after the lens is correctly focused. As soon as the self-timer has started, the self-timer LED will turn on and the shutter will trip after 10 seconds.

- While the self-timer is running, auto focusing in the "AF" or "CAF" mode is not possible.
- If you want to take self-timer pictures with the focus mode set to "AF" or "CAP", make sure the green LED in the viewfinder turns on by depressing the Shutter Release halfway' then operate the self-timer by depressing it all the way.
- To stop the self-timer after it has started, turn off the Main Switch...
- While the self-timer is running, an audible electronic signal will sound and the self-timer LED will illuminate in the following sequence:

When taking self-timer pictures in an auto-exposure mode, the extraneous light entering through the viewfinder eyepiece may adversely affect the exposure. Because this camera is designed to focus the lens and determine the exposure when the self-timer started, do not remove your eye from the eyepiece before the self-timer starts to prevent light from entering through it.

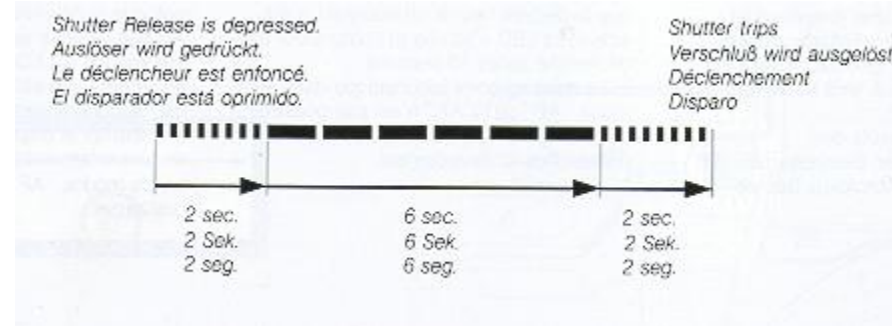

Trap Focus Shooting

The Yashica 230-AF features a trap focus system which allows the shutter to trip as soon as the subject comes to the distance at which the lens has been focused beforehand. If you use this technique, you can take photographs of nervous animals that are usually difficult to shoot. You need only wait for the subject to arrive in the scene with the fixed focus. Moving objects can also be shot at your desired distance and in the composition you like even in your absence.

1 After setting the Selector Lever to "MF", set the Focus Mode to "  ". While pressing the Focus Mode Button, move the Operating Lever to show the mark "  " in the display panel.

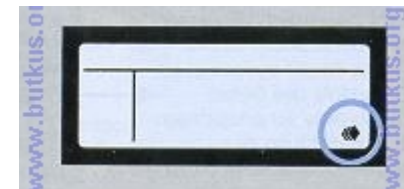
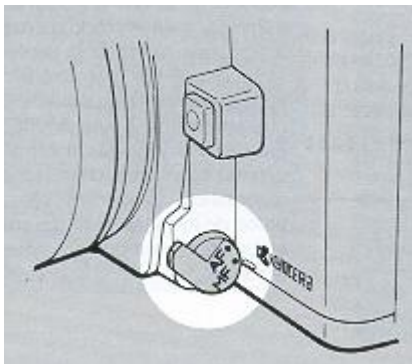

2 Set the Exposure Mode and Drive Mode and focus the lens. Set the desired exposure mode and drive mode depending on the subject and situations. Then turn and set the Focusing Ring to your desired distance or a distance at which your intended subject is expected to come.

* You cannot use the self-timer and bulb exposure in the trap focus mode....

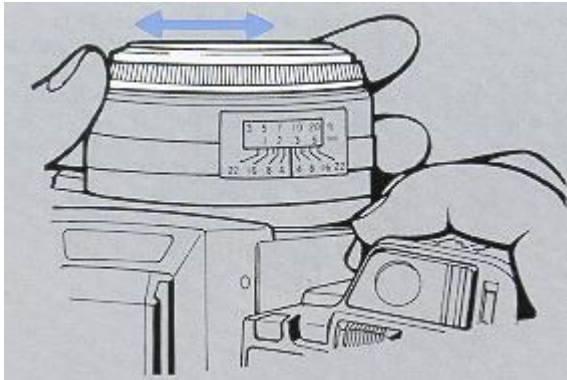

3 Place the camera, compose your picture and keep the Shutter Release in depressed position Face the camera toward the subject, choose your desired framing and keep the Shutter Release in depressed position with the Cable Switch. As soon as the subject arrives and it is caught in the Focusing Frame, the lens will focus on it and the shutter will trip to expose one frame if the Drive Mode is set to "S". If the camera is operating in the Drive Mode "C", it will take pictures one after another continuously while the lens is focused on the subject.

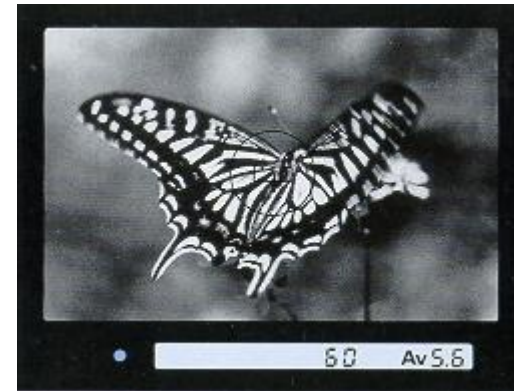

* While the camera is operating in the trap focus mode, its power switch remains on until the shutter trips.

* If you remove your eye from the viewfinder eyepiece when the Shutter Release is kept in depressed position, attach the accessory Eyepiece Shutter. For details, refer to the instruction sheet packed with it.

* To clear the trap focus mode after it was set, switch the Selector Lever to "AF"

* You can also use this trap focus technique with the AF Converter. In this case, first focus the lens in the "AF" mode and switch it then to the trap focus mode

Metering System

This camera offers two metering methods: center weighted metering and spot metering. Use these two methods depending on your subject and shooting conditions.

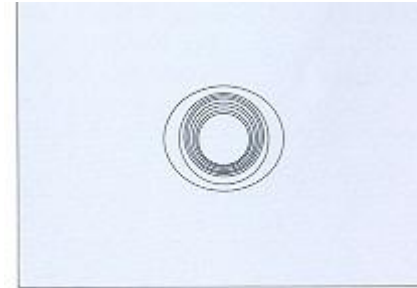
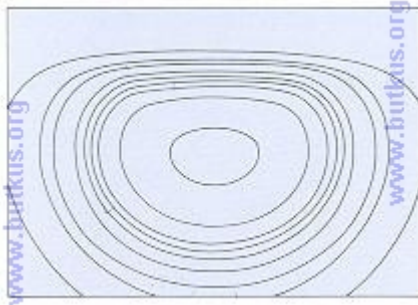

<Center-weighted Metering (Main Switch at ON)>

This method measures the light with great emphasis on the brightness of the subject in the central part of the picture frame and also takes the brightness of the surrounding area into account. It insures uniform exposure in the entire frame and reacts well to both bright and dark light, making it suitable for taking ordinary pictures.

Automatic Backlight Compensation

Even if your main subject in the center of the viewfinder is backlit, you can take beautifully exposed pictures of it because the exposure is automatically compensated. If the surrounding area is brighter than the center of the picture frame in backlit situations, the camera will automatically measure only the central part so that the main subject is not underexposed.

Spot Metering (Main Switch at AE - L)>

This method measures only the central part of the picture frame to determine the exposure. If the subject is very bright against the background, such as a spotlighted subject on the stage, or on the contrary, if the background is too bright compared to the subject, such as a backlit portrait, you can take sharp pictures using this method. It is also useful for producing a dramatic effect in your picture by setting exposure on a particular part of the subject.

* If you have selected the spot metering method, but if your subject is too dark for it, the camera will automatically switch to the center-weighted metering method to provide correct exposure.

AE Lock on Spot Metering

When the Shutter Release is depressed halfway in the spot metering mode, the measured exposure value will be stored in memory. This is useful for taking pictures on spot metering in an edge of the picture frame...

Taking Pictures on Spot Metering

1 Set the Main Switch at AE-L and aim the I Focusing Frame at the main subject. Thus, you can set the exposure value of your subject by spot metering.

2 Depress the Shutter Release

First, depress the Shutter Release halfway. The spot-value will be stored in memory by the AE Lock.

If the main subject is not in the center of the viewfinder, move the camera so that it is located in the Focusing Frame to focus the lens on it. Then, recompose your picture with the Shutter Release depressed halfway and take it by depressing the button all the way.

* If you take continuous exposure pictures in the drive mode "C" with an exposure value of the subject fixed by the AE Lock, all pictures you take will be uniformly exposed, unaffected by changes in lighting conditions in the background.

*Taken without spot metering/Ohne gezielter Nahmessung
Prise sans mesure ponctuelle/Tomada sin medición del índice luminoso*



*Taken with spot metering/Mit gezielter Nahmessung
Prise avec mesure ponctuelle/Tomada con medición del índice luminoso*



Manual Setting of Film Speeds

If you are using non-DX-coded film or if you want to shoot with a film speed that is different from that of your film, set the desired speed by pressing the ISO Button and operating the Operating Lever.

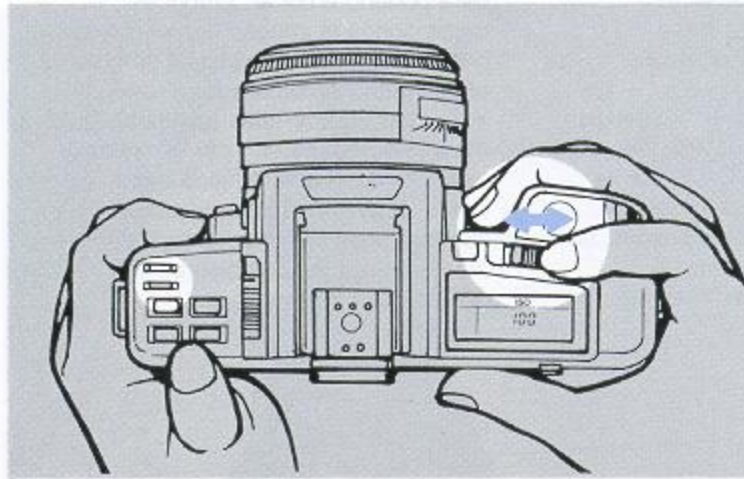
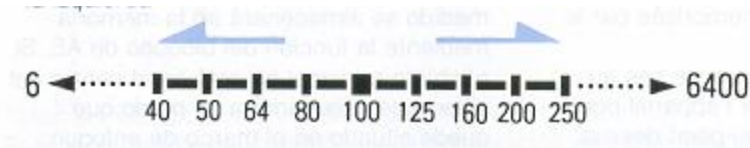

- Film speeds from ISO 6 to ISO 6400 can be set in 1/3-step increments.
- If you are using non-DX-coded film, press the ISO Button to confirm the ISO speed that is set.
- Once a film is loaded and its film speed is set, the ISO value that is set will not change until the film is unloaded, even if the power is turned off.---

Using the Exposure Compensation Button

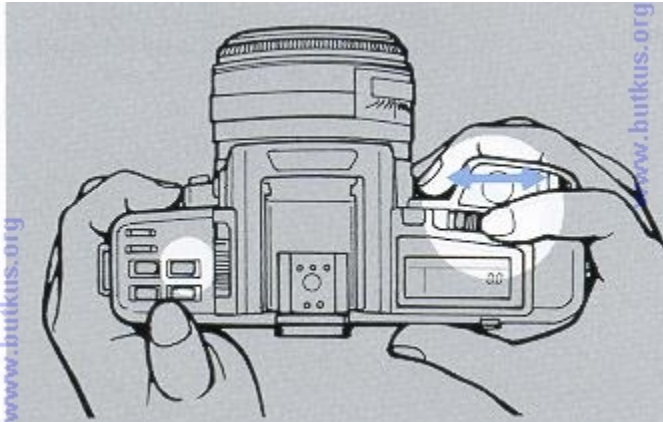

If you want to take intentionally overexposed or under exposed pictures in the auto mode, or an intended exposure is not obtained because there is an extreme difference in brightness in the same picture frame, exposure compensation is necessary.

If you press the Exposure Compensation Button, the mark "0.0" will appear in the viewfinder and display panel if no exposure compensation is made. To make exposure compensation, move the Operating Lever to the left or right while pressing the Exposure Compensation Button and show your desired compensating value in the display. Exposure compensation is possible in the range of +4.0 EV - -4.0 EV and can be set in 1/3-step increments.

After taking pictures with exposure compensation, always reset it: "0.0".

- During exposure compensation, only the + or - mark will turn on in the viewfinder and display panel.



For Backlighting Subject ± 0.3 ~ ± 4.0

If you are shooting your subject against the light, under a bright sky, on an ocean beach, in front of a window, etc., where a bright background occupies the greater part of the picture frame, the main subject will be underexposed and turn out dark like a silhouette. In such cases, use exposure compensation of ± 0.3 ~ ± 4.0 to give more exposure to it.



For Spotlighted Subject ∓ 0.3 ~ ∓ 4.0

If you are shooting a subject in spotlight where a dark background predominates in the scene, it will be overexposed and turn out light. In such cases, use exposure compensation of ∓ 0.3 ~ ∓ 4.0 to reduce the amount of light on it.



Depth of Field

When the lens is focused on a subject, not only the subject itself, but also a certain zone in front of and behind it will turn out sharp in the picture. This is called the depth of field of a lens and it varies as follows:

- (1) The smaller the aperture, the wider the depth of field, and vice versa.
- (2) The longer the subject distance, the wider the depth of field, and vice versa
- (3) The zone of sharpness behind the point on which the lens is focused is wider than that in front of it. In the case of different lenses, lenses with shorter focal lengths have a wider depth of field than those with longer focal lengths....

The zone of sharpness can be checked on the depth-of-field scale of the lens. If you are using a 50 mm F1.8 lens and shooting a subject at 2 m with an aperture of F16, for the camera will turn out sharp.

· Some zoom lenses are not provided with a depth-of-field



Dedicated Flash CS-110AF

The CS-110AF operates on a CPU-matic method. Because it takes its power from the high-performance lithium battery of the camera, its recycle time is very short so that you can take flash pictures one after another almost continuously.

< Margen del flash >

ISO	50 mm F1.8	35—70 mm F3,3—4,5
25	Aprox. 0,7—3 m	Aprox. 0,7—2 m
50	Aprox. 0,7—4 m	Aprox. 0,7—2,5 m
100	Aprox. 0,7—6 m	Aprox. 0,7—3,5 m
200	Aprox. 0,7—6 m	Aprox. 0,7—5 m
400	Aprox. 1—6 m	Aprox. 1—6 m
800	Aprox. 1,5—6 m	Aprox. 1,5—6 m
1600	Aprox. 2—6 m	Aprox. 2—6 m

< Flash- Range >

ISO	50mm F1.8	35-70mm F3.3 - 4.5
25	Approx. 0.7--3 m	Approx. 0.7--2 m
50	Approx. 0.7--4 m	Approx. 0.7--2.5 m
100	Approx. 0.7--6 m	Approx. 0.7--3.5 m
200	Approx. 0.7--6 m	Approx. 0.7--5 m
400	Approx. 1--6 m	Approx. 1--6 m
800	Approx. 1.5--6 m	Approx. 1.5--6 m
1600	Approx. 2--6 m	Approx. 2--6 m

· The illumination angle of this flash covers the field of view of 35 mm lenses. If macro pictures are taken with some types of lenses, however, it may not cover the entire picture frame because the distance from the lens to the flash reflector is short.

< Flash Mark and Automatic Shutter Speed Setting >

The flash will recharge in about 2.5 seconds and, as soon as it fully charged, the Flash Mark "⚡" will turn on in the display panel. At the same time, the shutter speed will automatically switch to 1/90 sec. if you are taking pictures in the auto mode. If you are shooting in the manual mode, the shutter speed will be automatically set to 1/90 sec. if it has been set to 1/90 sec. or faster, and to the shutter speed that is set if it has been set to a slower speed than 1/90 sec. The shutter will not trip and the auto-focusing system will not operate unless the flash is fully charged.

* If the aperture number blinks when the Shutter Release is depressed halfway, it warns that your subject will be underexposed because the flash light is not enough for it, or it will be overexposed because the amount of light is too much. In such cases, change the shooting distance so that the aperture number stops blinking.

After the flash is charged, if you do not take your flash picture immediately with the Main Switch on, check to make sure the mark "⚡" turns on by depressing the Shutter Release halfway before you shoot.

<Exposure Guide>

If you are shooting in the manual mode with the dedicated flash CS-1 10AF, you can easily find the correct aperture according to the shooting distance (with an ISO 100 or 400 film). First, estimate the distance from the camera to the subject with your eye. Then, find a distance value that is most close to your camera-subject distance in the left side of the table. In the right side of the table, you will find the correct aperture corresponding to the ISO speed of the film you are using. If you shooting a subject at a distance of about 2 m with an ISO 100 film, for example, you can take correctly exposed pictures if you set the aperture to 5.6.

m	ft	ISO	
		100	400
16	52		1.4
11	36		2
8	26	1.4	2.8
5.5	18	2	4
4	13	2.8	5.6
2.8	9	4	8
2	6.5	5.6	11
1.4	4.5	8	16
1	3.3	11	22
0.7	2.3	16	32

<Using Daylight Flash>



In the following cases, you can use flash even in the daytime. By using this technique, both the subject and background will turn out perfectly exposed.

- (1) When the subject is standing against a bright back" ground, such as backlighting portraits and people standing in front of a window;
- (2) When the subject is in the shade of a tree, or when the subject's face is illuminated by sunshine filtering through foliage;
- (3) Portraits in the early morning, In the evening or on a rainy day when the light is faint.





Flash Photography with Dedicated Accessories

When flash pictures are taken with the CS-1 10AF using an AF Converter or AF Extension Tube, the distance data on the lens is not correctly transmitted to the camera. In this case, you will have to set the aperture manually because it is impossible to obtain correct exposure in the auto mode. To set the aperture, refer to the exposure guide or calculate the correct aperture with the guide number 11 of this flash. If you want to take auto flash pictures with an AF Converter or AF Extension Tube, use the flash CS-250AF and shoot in the "Av" or "M" mode. It will allow you to take correctly exposed TTL auto flash pictures.

* If you take flash pictures with the CS-1 10AF, caution is required because part of the flash light may be cut by the lens front edge with some types of lenses and in close-ups.

Taking TTL Auto Flash Pictures

Combined with a TTL auto flash unit, this camera enables you to take auto flash pictures based on a TTL direct light metering method. When the flash selector is set to AUTO, the flash mark "  " will turn on as soon as the flash is fully charged. After making sure this mark turns on, depress the Shutter Release. The shutter speed is automatically set to 1/90 sec. in the programmed TTL auto flash and aperture-priority TTL auto flash modes. If you are working in the manual type TTL auto flash mode, you can choose any shutter speed in the range of B to 1/90 sec. The automatic flash range is very wide because the aperture is automatically set in the program mode according to the shooting distance (the same applies to the "TV" mode, too). As soon as the shutter is tripped, the required amount of flash is automatically adjusted by means of the camera's light receptor to provide correct exposure. After the flash has fired, the mark "  " will blink for two seconds to tell you that your subject is correctly exposed...

- The TTL flash units that operate on a TTL direct light metering method, such as Contax TLA 30, can be used in the same way.

Battery Replacement

If the voltage of the built-in 6-volt lithium battery (2CR5) decreases, the mark "  " will appear in the display panel and start to blink. Even if it starts to blink, the battery probably still has enough power for exposing two or three rolls of film (24 exposures). However, if you take flash pictures with CS-110AF, the battery will be drained quickly, so it is advisable to change the battery as soon as possible. If you continue to take pictures without changing the battery, the camera will no longer be able to operate at all as soon as the battery is completely exhausted.

- If the mark "  " turns on (without blinking), the backup battery is worn out. In this case, contact your nearest Yashica Service Station.
- This camera has a safety circuit for protecting its microcomputer from strong static electricity. However, it may fail to operate, though very rarely, as a result of the operation of this safety circuit. In this case, set the Main Switch at LOCK, press the Program Reset Button and operate the camera again to take pictures

< Battery Precautions >

- Generally, the battery performance is reduced temporarily by low temperatures. If you are shooting in cold weather, use a new battery and keep the camera warm before shooting. Even if the battery performance is reduced by low temperature, the battery will function normally again if the temperature returns to normal.
- Wipe both battery poles clean with a dry cloth before use, because poor contact may result if they are soiled by sweat, oil or grease.
- If you are going on a long trip, bring a spare battery with you.
- Do not throw a used battery into fire and do not attempt to disassemble, heat or short the battery because it is dangerous.
- Keep the battery out of children's reach. If it is swallowed, consult a physician immediately.
- The camera does not operate if the battery is loaded with its plus (+) and minus (-) sides wrong.

Release Socket

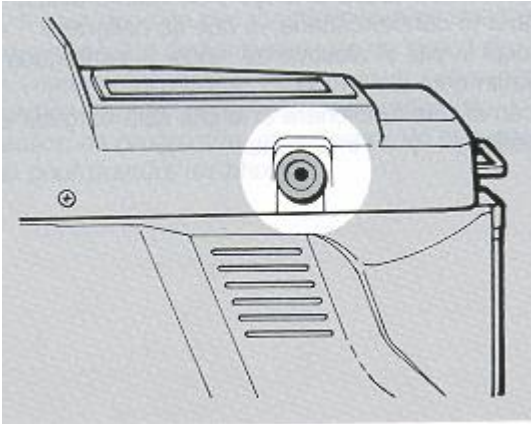

The Release Socket accepts such remote control units as the Cable Switch L, Infrared Controller S and Radio Controller. It transmits electric signal from them to operate the shutter.

- If you use the Release Socket in the focus mode "AF" or "CAP", caution is required because the shutter trips as soon as the lens is focused on the subject. If you do not want to miss any shooting opportunity, therefore, you will have to take pictures in the focus mode "MF".

- Do not connect a commercially available ordinary cable release to this Release Socket because malfunction may result.

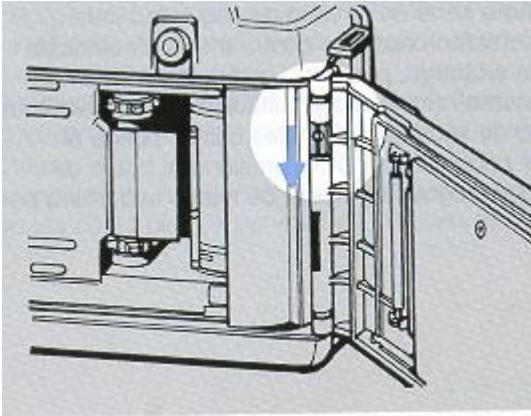

Interchangeable Camera Back

You can detach the Camera Back of this camera and install a Data Back DA-1 to print a date and time on your picture. It can be detached by pushing down the release pin.

ACCESSORIES



< Data Back DA 1 >

This is a quartz-controlled liquid crystal data back that can be used in place of the standard camera back and operates in full coupling with the body without cord. You can choose two printing modes for date and time. Its auto calendar enables automatic correction of leap years as well as months with a different number of days up to the year 2019.

<Flash CS-250AF>

Specially developed for Yashica auto-focus SLR cameras, the CS-250AF is a high-power flash with a guide number of 25 (35 mm, ISO 100). It is compactly built and provided with a zoom flash unit that can change the illumination angle to cover the angular fields of various lenses of 28 mm to 85 mm. It also has a supplementary light for the auto-focus system to permit focusing even in dim light so that you can take TTL auto-focus auto-flash pictures with ease. Because its flash head tilts upward up to 90°, you can enjoy sophisticated flash techniques such as bounce flash.





<AF Converter 1.6>

If you attach this AF converter to Contax/Yashica mount lenses, you can take auto-focus pictures with them. It also extends the focal length of your lens by 1.6 times. Since it transmits various lens signals such as automatic diaphragm signal, you can take sharp pictures without detracting from the excellent optical qualities of these lenses.



<AF Extension Tube MA-8.5>

Mounted between the camera and lens, this extension tube for autofocus SLRs enables you to take close-ups of flowers, insects, etc. with ease using the auto-focus system

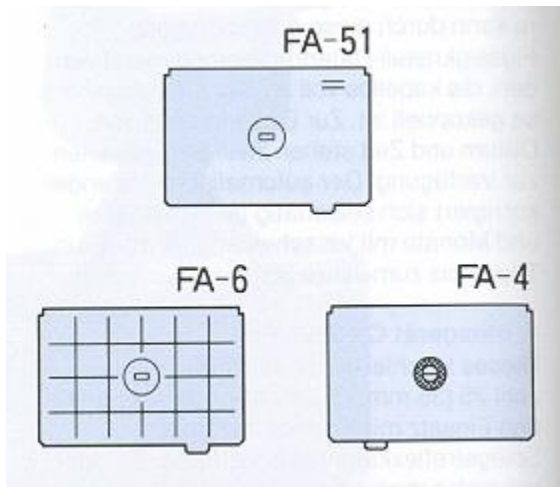

Focusing Screens--FA-4, FA-6 and FA.51 >

Besides the standard focusing screen for auto focusing (matte screen), there are three types of optional focusing screens matte screen for the Data Back, sectioned matte screen and horizontal split-image/ microprism collar screen. They can be interchanged depending on the shooting object and the lens used.

Camera Care

- Do not leave the camera in hot places (on an ocean beach in summer, in a parked car under direct sunlight, etc.) for a long time, because the camera, film and battery may be adversely affected.
- After taking pictures at the seaside or on mountains, clean the camera thoroughly. Salt air will cause corrosion and sand and dust will adversely affect the internal precision parts of the camera.
- To remove dust and debris on the lens and viewfinder glass, use an air blower or a soft lens brush. If they are soiled with fingerprints, wipe off lightly with lens tissue. Remove dust and debris on the mirror with a lens brush.
- The lens and viewfinder may be clouded if the camera is brought into a warm room from outside where it is cold. This cloudiness will disappear soon, but it is always advisable to avoid sudden temperature changes because water droplets will cause internal corrosion.
- If you are going to use the camera for important events such as an overseas trip or wedding ceremony, be sure to test it beforehand to make sure it functions properly. It is also advisable to bring a spare battery with you.
- To clean the camera exterior, wipe with a soft cloth. Never use benzine, thinner or other solvents.
- The camera contains high-voltage circuits. In case of malfunction, never to try to disassemble it because it is dangerous.

< Camera Storage >

- Keep the camera away from heat, moisture and dust. Do not store it in a wardrobe drawer containing mothballs or in a laboratory where there are chemicals that will cause damage to it.

To make full use of the capabilities of this camera, it is advisable to use our interchangeable lenses and accessories. We may not be able to make repair for the damage or trouble that might occur with products of other makes.

Specifications:

Type: 35 mm focal-plane shutter, auto-focus SLR with automatic film advance and rewind.

Picture Size: 24 x 36 mm

Lens Mount: AF mount

Shutter Electronic vertical-travel focal-plane shutter (quartz controlled).

Shutter Speeds: 1/2000 to 16 sec. in auto mode, 1/2000 to 16 sec. and B (bulb) in manual mode

Shutter Release: Electromagnetic release with release socket.

Exposure Control: 9 modes of exposure control:

- (1) Programmed auto exposure (P),
- (2) Shutter-priority auto exposure (Tv),
- (3) Aperture-priority auto exposure (Av),
- (4) Manual exposure (M),
- (5) Programmed TTL auto flash,
- (6) Aperture-priority TTL auto flash,
- (7) Manual type TTL auto flash,
- (8) CPU controlled flash (CPU-matic flash),
- (9) Manual flash.

Metering System: TTL full-aperture center-weighted metering TTL full-aperture spot metering (normal photography); TTL center-weighted direct light metering (flash photography); two SPD (silicon photo diode) cells.

Metering Range: EV 1--EV 20 (ISO 100, F1.8 lens).

Film Speed Range: ISO 25--5000 in DX auto mode, ISO 6--6400 in manual mode.

Autofocus System: TTL phase difference detection with CCD sensor located in lower part of mirror box; focusing is effected by depressing shutter release halfway; manual focusing possible; green LED turns on when subject is in sharp focus.

Auto-focus Sensing Range: EV 3--EV 20.

Focusing Modes: Auto focus (AF), continuous auto focus (CAP), trap focus (4') and manual focus.

Focus Lock: Activated by AF lock button. Focus is also locked by depressing shutter release halfway after subject is focused in AF mode.

AE Lock: Quantity of light on subject is stored in memory when spot metering is effected.

Exposure Compensation: +4 EV---4 EV (1/3-EV steps); provided with automatic backlight compensation on center weighted metering.

Self-timer: Quartz-control electronic self-timer with 10 sec. delay; cancelable in mid-run; operation is indicated by blinking self-timer LED and audible electronic signal; automatic AE lock on self-timer start.

Flash Synchronization: X contact; shutter speed automatically switches to 1/90 sec. with TTL flash when flash is fully charged; synchronizes at 1190 sec. or slower in manual mode; flash mark "  " turns on with flash charged and blinks to indicate correct exposure after flash has fired.

Viewfinder: Pentaprism eye-level finder (long eye-point type), 95% field of view, 0.82X magnification (with 50 mm lens at infinity).

Focusing Screen: Matte screen with focusing frame and spot circle; interchangeable screens available

Display in Viewfinder: LCD display Exposure compensation, shutter speed, film speed, aperture, over /underexposure, front mis-focus, rear mis-focus indicator, flash mark, exposure modes (P, Tv, Av and M). LED display Green sharp-focus LED.

Display Panel: LCD display Exposure compensation, shutter speed, film speed, aperture, over/underexposure, exposure counter, exposure modes (PROGRAM, Tv, Av and M), ISO indicator, electronic signal indicator, battery check mark, film transport/rewind mark, flash mark, drive modes (C, S, Hi)), focus modes (AF, CAP, ME and ).

Film Winding: Automatic loading with built-in motor; automatic film advance; automatic film positioning to first frame.

Film Rewind: Automatic rewinding with rewind switch; automatic stop when rewinding is completed; film can be rewound in mid-roll

Exposure Counter Automatic reset, additive type; counts up to 99.

Accessory Shoe: Direct X-contact hot shoe (with flash sync contact)

Drive modes: Single-frame shooting, continuous shooting and self-timer; continuous shooting up to about 1.8 frames/sec.

Camera Back: Can be opened by pushing down camera back lock; detachable; provided with film check window

Power Source: One 6-volt lithium battery (2CR5). —

Battery Check: Battery check mark blinks when battery voltage decreases.

Dedicated Flash CS-110AF: CPU-matic operation (variable aperture based on distance information); approx. 0.7--6 m flash range (50 mm F1.8 lens, ISO 100)

Battery Capacity: About 25 rolls of 24-exposure film can be exposed in AF mode (50% with flash)--according to Yashica testing standards.

Others: Direct contact for data back

Dimensions: 148 (W) x 93 (H) x 50.5 (D) mm

Weight: Camera . 530g (without battery) f lash CS-110AF 50g

** Specifications and design are subject to change without prior notice.*