

# Helsinki's New Tram

*ARTIC*



TRANSTECH



Made for Helsinki .....	p. 4-11
Made for passengers .....	p. 12-15
Safety .....	p. 16-21
Reliability and maintainability .....	p. 22-25
Innovative technology .....	p. 26-35
Advanced expertise .....	p. 36-47

ERICAL CUT-OUTS

# Made for Helsinki

The design of the Artic tram gives a clear message to its passengers: this tram is durable, of high quality and it will take its passengers to their destinations in all conditions. The design is rich in detail that celebrates the history of trams in Helsinki in the 1950s, 70s, 80s and the 2000's:

the buffer height, colour themes, windscreen visor, grey equipment space on roof and vertical front profile. The burgundy seats and the black floor create an elegant connection between the historical and modern tram, and create a visually pleasant travelling environment.

An important aspect of design and colour themes used is to make the tram fit seamlessly in various cityscapes, from the high-value properties in the historical city centre to modern commercial buildings. The design of the tram reflects elegance, modern efficiency and performance and cutting-edge usability.



# Designed for demanding conditions



Artic runs even the sharpest of curves and the steepest hills and valleys smoothly. It is also the first tram in the world to effortlessly master any combination of all three. The multi-directional articulations and freely-turning bogies ensure good passenger comfort and long vehicle structure service life in all conditions.

Artic stops even on the slipperiest track. All the wheels of the tram are driven and the maximum friction is ensured with a processor-controlled traction control system and automated sanding. The worse the weather, the more this tram is in its element.

The varying climate and demanding rail infrastructure of Helsinki, the capital of Finland, pose challenges to any tram design. The new tram, tailored for the varying conditions of Helsinki, takes all these special conditions into account.

Artic can be freely used in temperatures of  $-35\text{ }^{\circ}\text{C}$  and burning hot summer days alike. Whatever the weather, the passengers can enjoy the comfort of the air-conditioned tram. Floor heating ensures maximum comfort and prevents ice from accumulating in door steps or on the floor.

Artic is the first in the world to be heated by an energy-efficient breaking energy collection system based on the ability of water to absorb and provide energy.







## Known by its colour

In London they are red. In New York they are yellow. In Helsinki they are and will be green and yellow. Successful design of public transport vehicles hits home regardless of the colour.



## Spacious and light

The interior of Artic is made only of the best, wear-resistant materials that are easy to maintain, such as leather, plush, stainless steel and rubber. The seats are optimised with respect to passengers of various sizes and the average duration of a trip. Thanks to their carefully designed positioning, the seats are easily accessible and offer a view over other traffic in the street.

LED lighting and light-coloured panelling give the tram a spacious, elegant look, topped with spacious and well-lit gangways. A high number of stanchions and the smooth run of the tram make moving around easy.

HD-quality information displays and clear announcements help passengers to alight at the right stop. When the stop button is pushed, an indication light in all stop buttons indicates that the request has been registered. The requirements of passengers with special needs have been taken into account in the design of Artic.





## Special needs met

There is plenty of open space, and folding seats by external doors to allow easy access. The tram is easily accessible with a pram or a wheelchair.

To meet the needs of passengers using wheelchairs, Artic is equipped with a proven and handy mechanical folding ramp. The tram driver releases the ramp using a remote control system. Wheelchairs and prams can be attached to the loops located in the frame of the folding seats.

Thanks to the numerous stanchions and handles integrated in the backs of the seats, passengers can stand and move safely in the tram.





## Safety first

A cornerstone of design of the front has been the safety of pedestrians. Due to the shape of the lower part of the front the pedestrian does not fall under the tram in case of a collision but stays on top of the bumper. The structure of the bogie flaps ensures that the pedestrian's clothes do not become entangled with the rotating parts of the bogie. The colours and light positioning of the tram have been designed to maximise the safety of traffic.

Passenger areas are free of sharp edges to prevent injuries, the floor mat material has been particularly selected to offer maximum grip in all conditions, and numerous stanchions have been located to ensure passenger safety. Contrasting colours and materials are used to facilitate the journey of people with impaired vision.

All materials meet the high fire safety standards and do not emit dangerous amounts of toxic combustion gases in case of fire.

CCTV and wide gangways, together with the presence of the driver, ensure that passengers feel safe, even when riding the last tram at night.

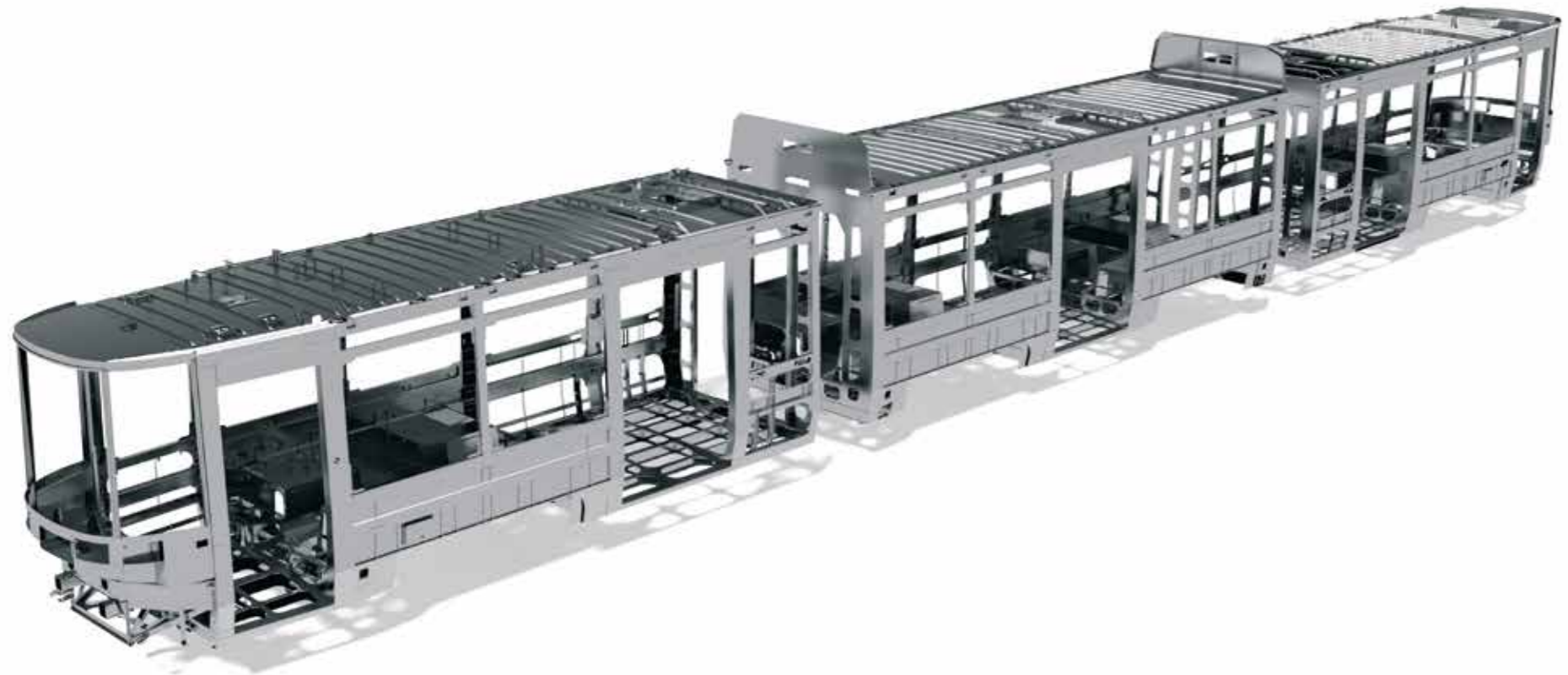

## Safe and reliable

The bodyshell is made of special steel. As a result, the structure is safe, very strong and resistant to the wear and tear of heavy city traffic and varying loads. The bodyshell will remain free of corrosion problems even in the most demanding climatic conditions.

In terms of the design of the bodyshell and the choice of materials, particular attention has been paid to demanding climatic and rail infrastructure conditions and the high incidence of collisions. All materials and structures are highly resistant to corrosive environments and fatigue loads. They are also easy to repair if necessary. The bodyshell is made of weather-resistant special steel and is welded in compliance with the latest, most stringent welding requirements for rail vehicles (EN15085).

The carefully designed bodyshell structure maximises the safety of both passengers and the driver in busy urban traffic. The bodyshell has been designed to meet the structural requirements of EN12663 for static and fatigue loads as well as the requirements of EN15277 in various types of collisions.

High visibility  
in all conditions

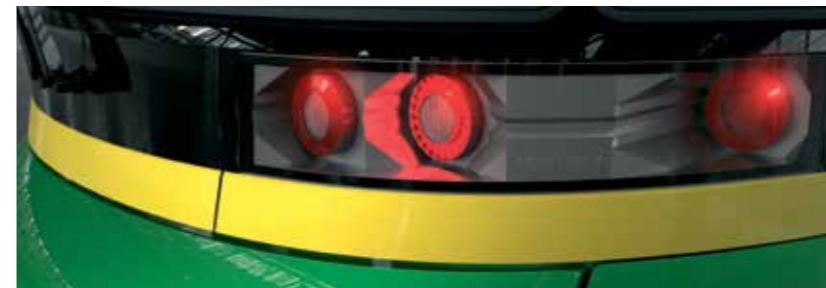

Apart from high beams, all the external lights of Artic are LED lights. The advantages of LED lights include high illumination efficiency and long maintenance intervals.

The line displays are also made of white LED light texts in order to ensure visibility both in bright sunlight and on dark nights.



## Reliable

Reliable service is a careful combination of the cutting-edge products of the best component manufacturers, redundancy of several operationally critical sub-systems, and the constant registering of tram status data.

The service and repair actions of Artic, collision repair works included, have been analysed in great detail during the design process. Thanks to this dedicated expert work, the outcome is a modern tram, which has low life cycle costs and which is easy and quick to service and repair.

# Service and maintenance

In addition to the passengers' comfort, the design of the tram focuses on excellent availability and maintainability.

The external and internal panelling, bogies and electrical components can be rapidly dismantled and mounted, which minimises the time spend on service and repair. Instead of unreliable and troublesome bonding, all components of Artic have been mounted using the quick-clamping system, thanks to which components can be easily dismantled and replaced. The panel sizes have been optimised for the damage caused by the most common collisions, in order to ensure that repair is fast and the tram can be returned quickly to service.

The time needed to replace the side and end windowpanes of Artic has also been kept to the minimum. All windowpanes can be dismantled and replaced without keeping the tram out of use, waiting for the glue to dry. External panels with windowpanes can be rapidly replaced with the quick-clamping system and replace a broken windowpane later. The curved side windows and the windscreen are attached to the bodyshell using a rubber wedge element system, which ensures easy and fast replacement.



## Modern energy-efficient electric drive

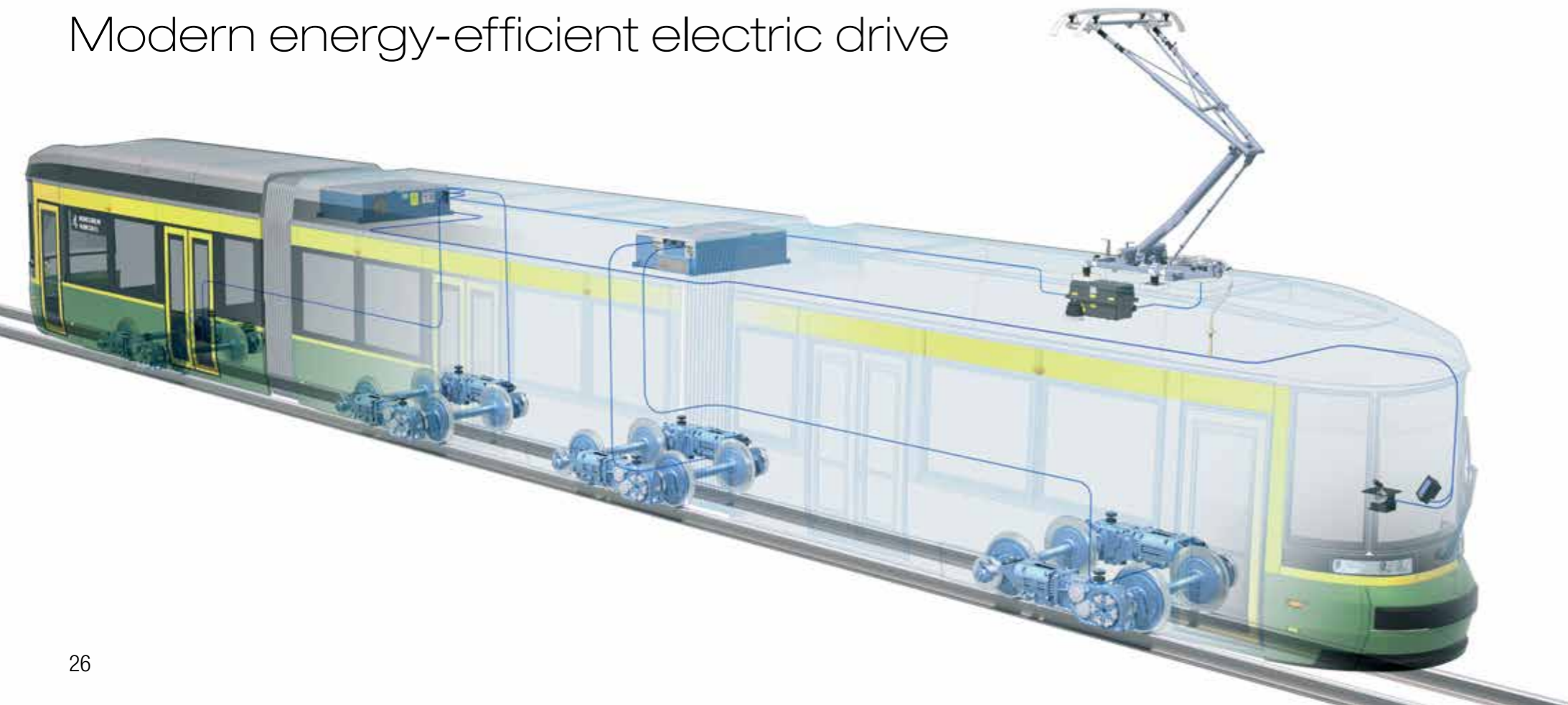

Transtech Artic is equipped with the cutting edge electric drive manufactured by Voith. Artic has eight traction motors and four inverters. Thanks to the four independent circuits with two motors each, the tram works perfectly even if one of the bogies and its motors are taken out of use. This configuration also ensures that Artic both accelerates and stops efficiently, even on slippery tracks. The inverter control units are equipped with the latest processor technology and communicate with each other using the high-speed CAN bus. Artic also has an automated operational data recording system which records and sends data to the server located at the depot.

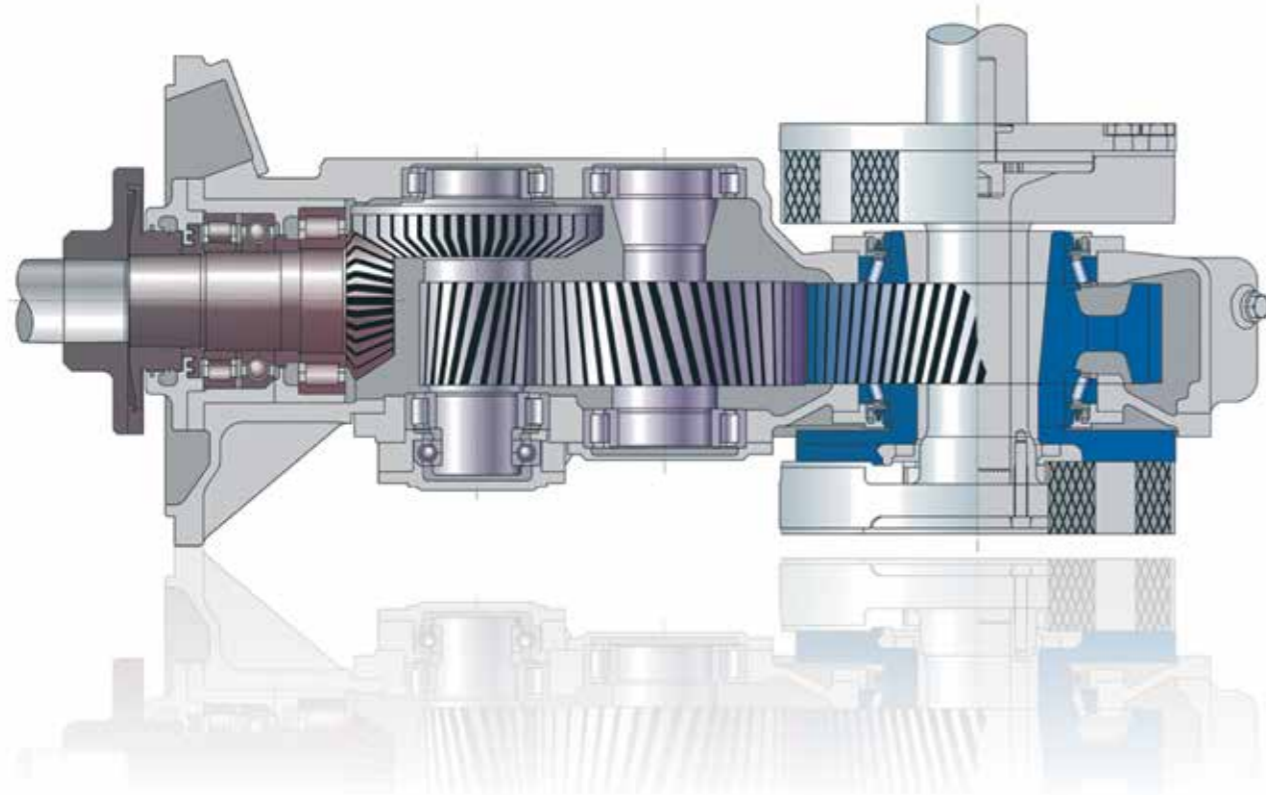

## The heart Artic

The heart of the excellent running behaviour of Artic is the three-phase reduction gear KSH-216, tested in numerous applications and manufactured by Voith. The gear transmits the high-power torque created by the traction motor to the axles and further to the tram wheels. The special characteristic of the component is the short cardan-type switch, which is made of rubber and metal elements and installed inside a partly hollow gear box. The gears are mounted on the bogie frame and thus do not increase the unsprung mass of the tram. Thanks to the low unsprung mass together with low axle weight, Artic runs silently and smoothly over switch points and crossings.

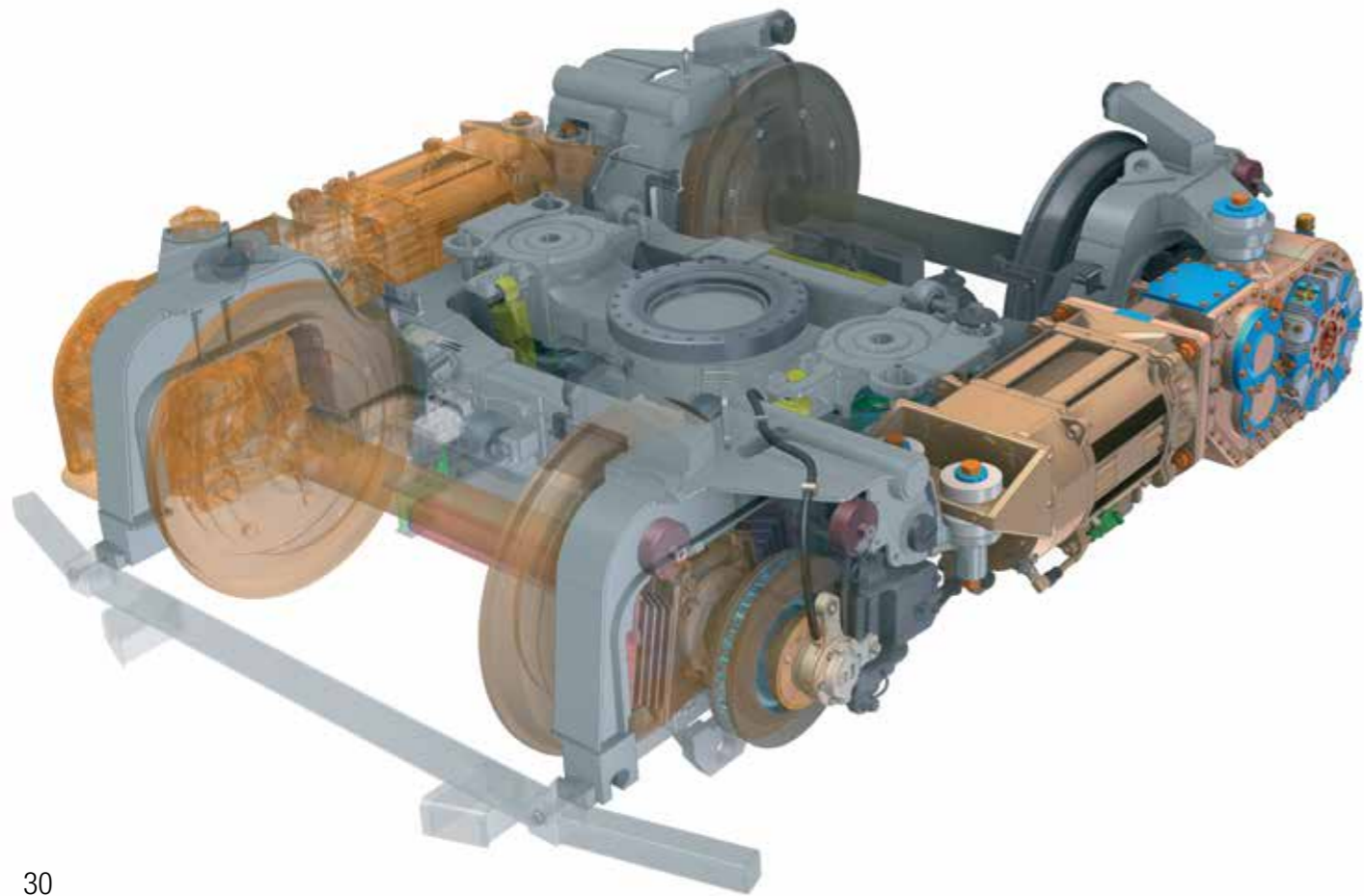

## Excellent running behaviour, unbeatable reliability

The bogie of Artic combines proven high-quality solutions with the latest low-floor technology. The bogie structure is based on the articulated bogie solution, which has been successfully used in rail vehicles for decades. The bogies consist of, among others, traditional wheelsets with continuous axles, coil springs in secondary suspension and large wheels. These highly reliable solutions combined with the low-floor structure, short wheelbase, very flexible rubber elements in wheels, and compact traction chain result in a tram that runs reliably and cost-efficiently in the most demanding conditions for years on end.

The advantages of the bogie solution include excellent running behaviour, even in the most challenging track conditions, its light weight, minimal wear and tear on wheels and rail, and low life cycle costs.

Axle load max.	9.0 t
Gauge	1,000 mm
Bogie wheelbase	1,700 mm
Wheel diameter, new	680 mm
Designed speed	80 km/h
Brakes	Electric, hydraulic, magnetic
Gear	Three-phase KSH-216
Suspension	Wheel, primary, secondary





## More light, less energy

The interior lighting of Artic is based on the latest maintenance-free, energy-efficient LED technology.

The new LED technology has many advantages over the previous lighting system based on fluorescent tubes. Thanks to the LED technology, between 40 and 60% of energy can be saved without compromising on the quality of lighting. The lights are recyclable and their service life is many times longer than that of fluorescent tubes. In addition, they are more reliable and their luminosity is easier to adjust.

The interior lighting consists of four LED light rows installed in the ceiling. Two of the rows are directed towards the floor through diffusers and two rows illuminate the middle part of the ceiling, thus bringing indirect light inside the tram. The luminosity is automatically adjusted depending on the light conditions, which ensures that from the passengers' point of view lighting is always pleasant and ample.



## Technical data

Parameter	Value	Note
Length	27,600 mm	
Height (from the rail)	3,830 mm	Pantograph lowered
Maximum width	2,400 mm	
Seats (+folding seats)	74 (+14)	
Standing passengers (technical capacity)	125	5 passengers/m <sup>2</sup>
Distance between bogies (middle)	5,000 mm	
Distance between bogies (from centre to end)	7,150 mm	
Floor height from the rail	max. 520 mm	
Doorstep height from the rail	360 mm	Nominal
Tare weight	43,400 kg	
Tare weight + driver + seated passengers	48,950 kg	AW0
Tare weight + driver + seated passengers + standing passengers (4 passengers/m <sup>2</sup> )	56,450 kg	AW1
Tare weight + driver + seated passengers + standing passengers (5 passengers/m <sup>2</sup> )	58,320 kg	AW2
Maximum axle load	7,850 kg	AW2 load
Wheel diameter	680 mm	
Bogie wheelbase	1,700 mm	
Nominal gauge	1,000 mm	
Minimum turning radius, horizontal	15 m	
Minimum turning radius, vertical	110 m	
Maximum speed	80 km/h	



## Designed with drivers

The front dashboard has been designed in cooperation with specialists in ergonomics and tram drivers. The objective of the careful design project was to create a visually pleasant dashboard that supports good working ergonomics for the driver. The dashboard is positioned in such a way that all controls are within easy reach and all information is available in one glance. The dashboard includes two 10.4" LCD displays that indicate the status of various tram systems using clear symbols. They assist the driver in the selection of the right route and allow the adjustment of tram systems.

The master controller is fixed in order to ensure reliability and stability of the structure. It has been equipped with a system that constantly monitors the alertness of the driver. The controls of acoustic signals and the running direction selector are integrated in the master controller.

The driver's seat is leather and it can be electronically adjusted to six different positions for optimum comfort. The seat can be equipped with a system that records the preferred settings of each driver. The driving posture is ergonomically healthy and all details are carefully designed, such as eye contact with passengers, which is at a pleasant level. The sun shades can be electrically adjusted and the driver can monitor areas inside the tram and its immediate vicinity through a display showing the footage of eleven cameras installed in the tram.

The driver has an unobstructed view to the street from the cockpit, thanks to the narrow window frames made of special steel. The visibility range has been tested using computer simulation. The driver has personal air conditioning and heating equipment which ensures a pleasant cockpit temperature in all weather conditions.

## Made for heavy use

The cornerstones of design and engineering have been safety, user-friendly economic use, passenger comfort and reliability. In order to ensure user-friendly design, various user and special groups were consulted and they had a significant impact on the tram from the first stages of the work.

All engineering and design solutions are based on the foundation of the 'form follows function' principle, thanks to which the tram will remain looking as good as new for years to come. All details have been carefully designed: Artic boasts rapid wheelset change, quick-clamping system external panels and a service-free body-shell, to name but a few. Thanks to the ingenious basic structure, all loads on wearing parts are minimised – and the number of passengers is maximised. Artic seats the highest number of passengers in its class.



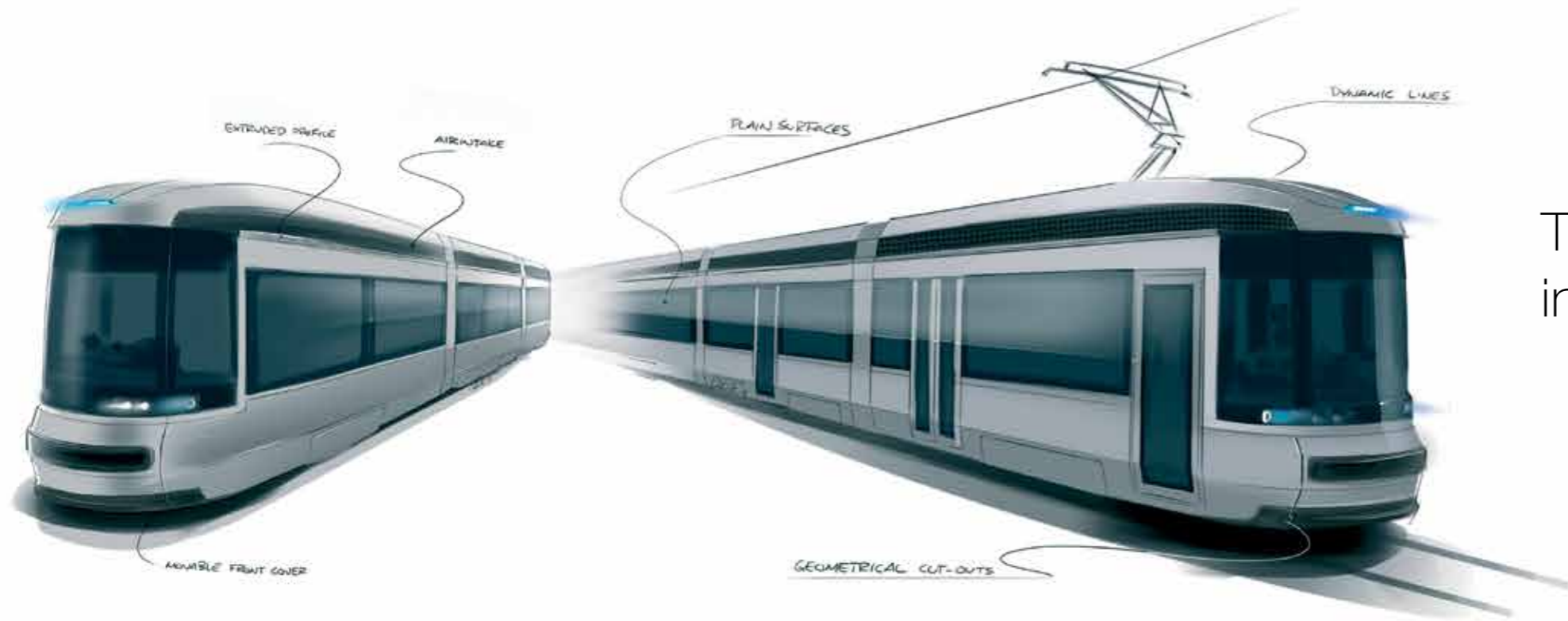

## Timeless and modern industrial design

The design process was carried out in cooperation with the industrial design studio IDIS Design Ltd, selected by Transtech, and interior designer Jouni Riikonen, appointed by Helsinki City Transport (HKL). The end result is a durable, fresh and modern product that fits perfectly in the varying cityscape of Helsinki.

# Invisible innovations

The composite floor is fully heated, which ensures that ice does not collect on the floor, regardless of the outside temperature. To ensure maximum energy efficiency, the sensitive temperature adjustment system communicates with the other heating components of the tram. Braking energy is also collected and used for heating the floor.

Reliable sanding equipment is based on a decentralised pneumatic system in which every wheel of the tram is equipped with a small compressor unit. Carefully targeted sand blowing creates optimal traction with a minimum use of sand and particle emissions. Whenever wheels slip, automated and unnoticeable sanding begins. Sand containers can be easily refilled: the large hatches are located under passenger seats and they are easy to open.

Artic is equipped with an innovative folding dashboard for reverse driving. When the dashboard is folded away, there's a normal passenger seat, which means that no space is wasted. The robust secondary dashboard contains all the relevant controls to manoeuvre the tram – easily accessible and at the right height. Reversing the tram is therefore easy and visibility is excellent.

During the winter, hundreds of kilos of snow and sleet may accumulate on the roof of the tram. As it melts, moisture usually penetrates in the structures and equipment of a tram. Artic tram sports a lightweight yet tight composite roof cover, which prevents the accumulation of snow in roof structures and, when seen from above, gives the tram a smart look. The cover is hatched to facilitate servicing.





## Joint forces for your benefit

Helsinki's new tram Artic is manufactured in cooperation with the leading specialist component suppliers, such as Voith, Hanning & Kahl, Ultimate, Lumikko and Joptek. The seamless and close cooperation ensures reliable delivery and efficient high-quality production. We always listen to our customers' wishes with a keen ear and customise each tram to meet the specific needs and environmental conditions of each customer.





**Helsinki City Transport (HKL)** has two service depots, one in Koskela and the other in Töölö. Collision repair and heavy-duty repair work are carried out at the Vallila workshop. All units operate in compliance with high environmental and safety standards.

All electricity used by HKL is generated as hydropower. HKL has its own rail vehicle R&D unit, which designs and manufactures e.g. tram bogies for HKL's own use.



**Transtech Ltd.** is a Finnish railway vehicle supplier and manufacturer of engineering products. Transtech specialises in the manufacture of low-floor trams and double-decker InterCity and sleeping cars and bogies. Transtech employs about 500 people and its annual turnover is approximately EUR 80 million. The heated surface area of Transtech's Otanmäki Works in Kajaani, Finland, is 52,000 m<sup>2</sup>. The entire manufacturing process is carried out in a heated indoor production facility from the receipt of materials to the delivery of a tested product. The main raw materials used are aluminium and structural steel. Aluminium is used in particular in the bodysells of passenger coaches. Structural steel is used in bodysells of trams as well as bogies, among others.



**Voith Turbo GmbH**, situated in St. Pölten, Austria, is a company that specialises in electro-mechanical operating systems for rail vehicles. Voith Turbo is part of the global Voith Group. The St. Pölten Works was established in 1903. The works now employ about 1,500 people and its annual turnover is approximately EUR 550 million.





Layout & Visualizations: IDIS Design Ltd.

[www.hkl.fi](http://www.hkl.fi) :: [www.facebook.com/liikennelaitos](https://www.facebook.com/liikennelaitos) :: [www.transtech.fi](http://www.transtech.fi)

