

**UNITED STATES DISTRICT COURT FOR THE
DISTRICT OF MASSACHUSETTS**

MARIA ALEJANDRA CELIMEN SAVINO,
JULIO CESAR MEDEIROS NEVES, and all
those similarly situated,

Petitioners-Plaintiffs,

v.

STEVEN J. SOUZA,

Respondent-Defendant.

Case No. 1:20-cv-10617 WGY

BRIEF ON CURRENT STATUS OF BRISTOL COUNTY HOUSE OF CORRECTION

INTRODUCTION

On April 15, 2020, the Court denied Defendant's Motion To Stay Further Releases, finding that "compelling issues of individual, institutional, and community health preclude the luxury of a stay" ECF 86. Yet Defendant, in its Input Regarding April 16, 2020 List, filed later that same day, continues to "urge the Court to stay further releases, as there has been no finding by the Court, nor proof by Plaintiffs, that further releases are required to establish appropriate detainee density at BCHOC." ECF 88 at 2. Over numerous filings, Defendant has persisted in its argument that the congregate living conditions at BCHOC do not pose an unreasonably unsafe risk to detainees, despite being unable to present any expert evidence in support of this proposition. On the other hand, Plaintiffs have amply shown that conditions at BCHOC remain unreasonably unsafe, through numerous class member and expert declarations. *See, e.g.*, ECF 12, ECF 32-3; ECF 68, Exs 1-3. To further amplify this record and assist the Court in its daily evaluations of the evolving situation at BCHOC, Plaintiffs hereby submit additional evidence bolstering the critical ongoing need for further releases.

I. **The Bristol County House Of Correction Remains Unreasonably Unsafe Because Social Distancing Is Not Currently Possible There.**

The Court's orders to reduce the population at BCHOC have been an effective start in addressing the critical underlying problem – the sheer number of people forced to sleep, eat, and breathe in the same enclosed space, at a time when a lethal virus that thrives on such density is rampaging across the globe. However, the unreasonably high risk remains, and the congregate living quarters at BCHOC are still a dangerously tight tinderbox for a mass infection. Detainees, staff members, and correctional officers, will remain at severe risk of harm unless the population is substantially reduced further by the Court continuing to place detainees on bail where appropriate. Without additional information from Defendant, Plaintiffs cannot at this point

identify a specific number of persons that BCHOC could safely detain at its facilities. The evidence, however, shows that the congregate living conditions, including dormitory-style bunk beds and cells still crowded with multiple people, are currently far too unsafe to satisfy the requirements of the Fifth Amendment.

Contrary to Defendant's conclusory assertions, the facts put forth *even by Defendant* clearly demonstrate that BCHOC does not have enough space in its congregate living areas to allow the current number of detainees to practice social distancing. The CDC's social distancing guidelines encourage increasing the physical distance "between all individuals, regardless of the presence of symptoms," to 6 feet or more.¹ For correctional institutions, the CDC recommends reassigning bunks to provide "ideally 6 feet *or more* [of space] in all directions." *Id.* (emphasis added). Defendant's recent submissions reveal that the current detainee population remains much too high to allow for such spacing. Among some of the more obvious examples, some detainees are still sleeping in top and bottom bunks only three feet apart, and in one unit, 54 people are sharing a communal bathroom with a small number of toilets, sinks, and showers in close proximity. *See* Declaration of Steven Souza ("Souza Decl."), ECF 83, ¶¶ 4-5.

Defendant attempts to portray the facilities as adequate by presenting hand drawn schematics of bunk arrangements, assuming that class members will remain frozen in place, and arguing that in situations where bunks are lined up 7-34 inches apart, that detainees' "heads" will still be 6 feet apart at night. *Id.* The CDC guidelines, however, preach the separation of "*individuals*" not just their "*heads*." There is no mystery why. It is now common knowledge that COVID-19 can be easily spread if droplets from an infected person's cough land on

¹ CENTERS FOR DISEASE CONTROL AND PREVENTION, *Interim Guidance on Management of Coronavirus Disease 2019 (COVID-19) in Correctional and Detention Facilities*, available at <https://www.cdc.gov/coronavirus/2019-ncov/community/correction-detention/guidance-correctional-detention.html>.

someone else's hand, and that person later touches his or her eyes, nose, or mouth. It can also spread if a droplet lands on an object, like a bunk, and is then touched by another person who later touches his face.² It is apparent even from Defendant's static drawings that detainees are sleeping in bunks that are less than 6 feet from another detainee's bunk.

Furthermore, even if the Court were to indulge Defendant's argument about the distances between sleeping detainees' heads, the distance is clearly inadequate for the simple reason that people inevitably move, breathe common air, and come into contact with common surfaces. For example, when a detainee in Unit A or B has to get up to use the restroom, it is *impossible* to pass down the aisle between bunks while staying six feet or more from others. *See* Supplemental Declaration of Carlos Menjivar-Rojas ¶ 3. The aisles are too narrow. To illustrate this point, Plaintiffs submit the Declaration of Jen Shin, a master's candidate at the Yale School of Architecture, who used architectural software to create a scaled, three dimensional model of each unit that houses class members by inputting the dimensions and other information contained in the declaration of BCHOC superintendent Steven Souza, which Defendants submitted on April 14, 2020. Declaration of Jennifer Shin ("Shin Decl.") ¶ 6.³ The exhibits to her declaration show sleeping detainees in red, and a detainee standing in the aisle in blue. The blue shaded area or circle marks a 6-foot radius around the standing person:

² *See, e.g.*, Second Supplemental Declaration of Matthew Gartland, M.D. ("Second Supp. Gartland Decl.") ¶¶ 9, 16.

³ Ms. Shin's diagrams were reviewed and their accuracy confirmed by the Dean of the Yale School of Architecture, Dr. Deborah Berke. *See* Shin Decl. ¶ 21.

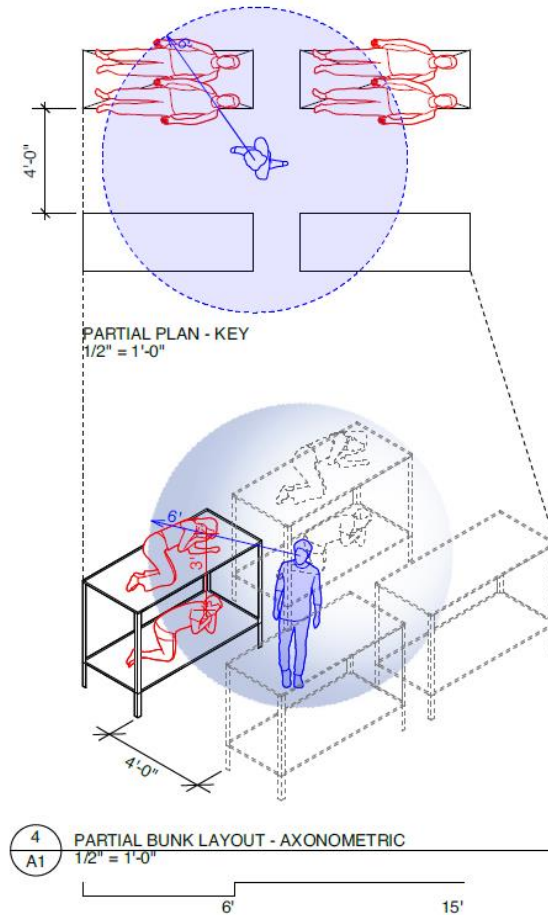

If the standing detainee walks the length of the aisle to get to the bathroom, he will come in close contact with everyone in the row—and could infect all of them. As these illustrations show, Defendant’s recent reconfigurations in no way solve the density problem. In addition to the narrow aisles, people in Unit B, for example, have also noted that while they now occupy every other row of bunk beds, “bunk-mates . . . have to touch the beds when . . . getting in and out.” Declaration of Lloyd Carter Wafula ¶ 2.

Dr. Elizabeth Singer, a physician with long-standing experience providing healthcare to immigrants in detention settings, explains that, given the layouts and current population densities, “it is impossible for detained individuals to maintain social distancing in the congregate living quarters in the C. Carlos Carreiro ICE Units A and B and the congregate living

quarters in the 2 East Unit.” Declaration of Elizabeth Singer (“Singer Decl.”) ¶ 29. In her review of the diagrams depicting the sleeping quarters and current population densities in those units, Dr. Singer concluded that “the physical impossibility of maintaining social distancing is necessarily true during the night when individuals are forced to sleep in an open environment, densely packed with bunk beds.” *Id.* ¶ 30.

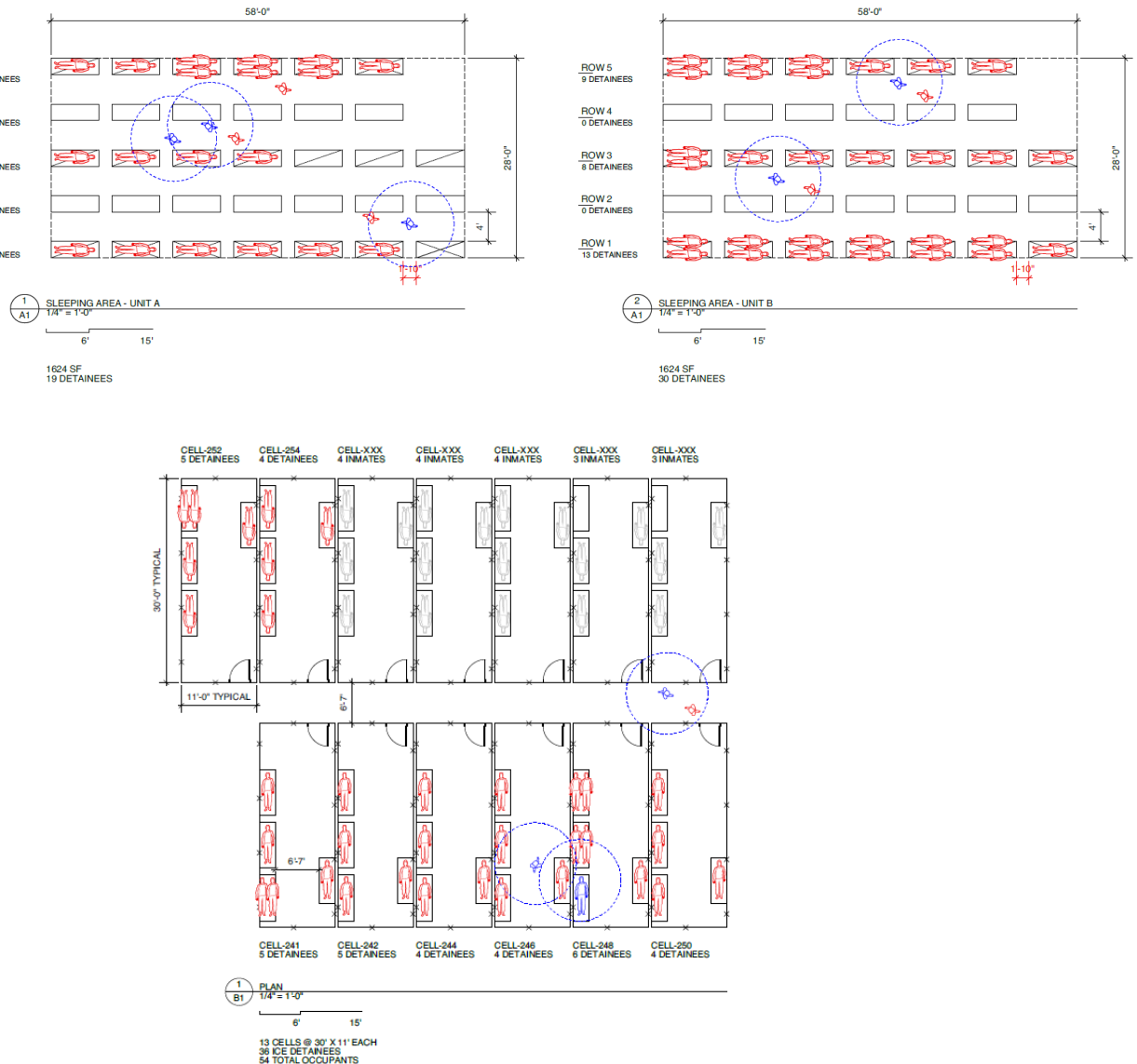

The dangerously tight spacing at BCHOC is not limited to the sleeping area. Dr. Singer further explains that in each of the four units at BCHOC, “it is impossible for the current density

of detained individuals to maintain social distancing in the shared bathrooms in each [unit].” *Id.* ¶ 31. Throughout the day, detainees are in close proximity with one another in communal areas like bathrooms, dining areas, and recreational areas. For example, as reflected in the Souza Declaration, in the 2 East Unit, 54 immigration and pre-trial detainees share two small communal bathrooms (21’ x 9’), one with three toilets and the other with four. Souza Decl. ¶ 7. In Unit A, 19 detainees share a single bathroom with six toilets. *Id.* ¶ 12. In Unit B, 30 detainees share a single bathroom with six toilets. *Id.* ¶ 14. And in the EB Unit, 11 women share two bathrooms that each have two toilets. *Id.* ¶ 3; *see also* Declaration of Angela De Jesus Concepcion ¶ 6 (“There is a small room that contains the law library, a TV, and a sink. It is hard to maintain space in this room because the area is very small. . . Only two people could safely be six feet apart in this room, but there are more than two people in this room regularly.”). The other facilities, including sinks, showers, and dining tables are just as congested, all creating scenarios where detainees and staff cannot pass one another while maintaining six feet of distance. *See* Shin Decl., Exs B, C, D.

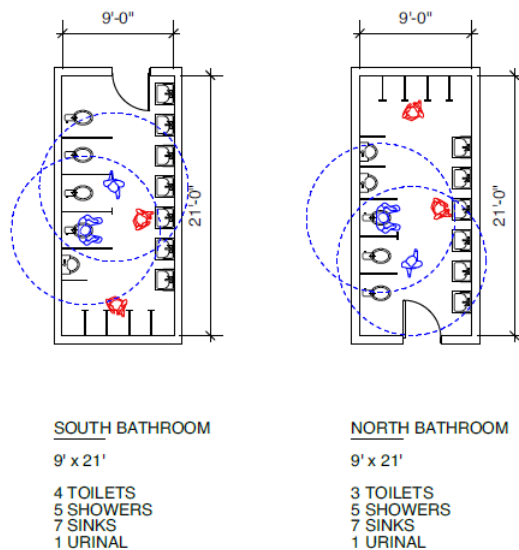

Thus, the critical question at the heart of this litigation – how many people can safely live in the tightly confined spaces at the Bristol facilities – cannot be answered simply by showing that it is theoretically possible to position people 6 feet apart at any one moment in time, or by considering social distance only when detainees are sleeping and immobile. Rather, the question is, how do class members actually live and exist in the Bristol facilities, and does that satisfy what the CDC and public health experts instruct about risk mitigation. Based on the evidence in the record, the answer is clearly no. The population must be reduced to a density that permits social distancing of at least six feet, and preferably more, when detainees and staff are going about daily necessities in order to reduce risk of transmission. This is especially so given that a six foot separation may not be enough. Developing research shows that respiratory droplets can carry the virus up to 23 - 27 feet under certain conditions. Second Supp. Gartland Decl. ¶ 16.

II. BCHOC Remains Unreasonably Unsafe Because The Dense Conditions There Increase the Risk of Infection Through Shared Surfaces.

The density at BCHOC is highly problematic not only because it makes social distancing impossible, but because it greatly increases the risk of infection through shared surfaces. The virus may also be transmitted through contaminated surfaces, where the virus can live for up to 72 hours. *Id.* ¶ 9. Any plan to prevent transmission for the virus must take into account not only social distancing but surface transmission, a near impossibility when 30 detainees share a single living space with high-touch surfaces like bathrooms, sinks, doors, as they currently do in ICE Unit B, or when 54 ICE and state pre-trial detainees share two bathrooms, as they do in Unit 2 East. Souza Decl., ECF 83, at ¶¶ 4, 8.

Mealtime continues to present a dangerously high risk of infection. In Unit B, for example, meals pass between 3-4 sets of hands before reaching the detainee: “one person hands

out a tray, one hands out a juice, one hands out bread, and one hands out butter.” Wafula Decl. ¶ 3. Not only does this place individuals in close proximity to each other on an ongoing basis, it also heightens the risk of transmission through shared surfaces. As Dr. Matthew Gartland, a doctor at Brigham and Women’s Hospital who has treated patients at BCHOC explains, “[i]f this [food service] pattern is repeated with a rotation of servers, then one asymptomatic infected individual could expose the entire detained population within a matter of days.” Second Supp. Gartland Decl. ¶ 13.

Moreover, the measures that Defendants claim to be taking, and propose taking, to prevent the transmission of COVID-19 within the facility are, in the expert view of Dr. Allen Keller, neither meaningful nor effective. Critically, the steps “do not, in any way, address the fact that COVID-19 infected individuals who are not yet showing symptoms, or who remain asymptomatic, are nonetheless still highly contagious to others.” Supplemental Declaration of Allen Keller, M.D. (“Supp. Keller Decl.”) ¶ 19. Furthermore, the “limited, if any, COVID-19 testing done at the facility” amplifies this risk of transmission. *Id.* ¶ 21; *see also id.* ¶ 27. Other procedures that Defendant touts, including sanitizing, *id.* ¶ 37, ventilation *id.* ¶ 43, and screening of new admissions, *id.* ¶ 47, are similarly “substandard.” *Id.* ¶ 37. Dr. Singer adds that BCHOC’s sanitizing practices actually *increase* the risk of infection with COVID-19: “Because detained individuals are tasked with cleaning the facility, and are given insufficient personal protective equipment and inadequate cleaning supplies, the procedures above heighten the risk of exposing a large number of individuals to infection.” Singer Decl. ¶ 36. Moreover, even if common spaces were cleaned adequately several times a day, multiple people would have come into contact with those surfaces in between.

Finally, although Defendant continues to insist that there are “no cases of COVID-19” inside BCHOC, *see* Memorandum In Support Of Motion To Stay Further Releases at 2, this is in fact unknown, as there appears to have been no testing of the detainee population. Moreover, even if it could be said that there are currently no cases of COVID-19 among the detainee population, it is “naive and foolish to believe that this in any way assures there will not be substantial infections in the future. From a health perspective, [BCHOC] is a COVID-19 ticking bomb.” Supp. Keller Dec. ¶ 25. This is especially true given that there are now four reported cases of BCHOC staff testing positive for the virus. Singer Decl. ¶ 16; *see also* ECF 86 (Order Denying Defendant’s Motion To Stay Further Releases) (“We are in the midst of a pandemic unprecedented in our lifetime. Past experience is an uncertain guide to meeting the challenges of today.”).

CONCLUSION

As this Court’s release orders to date have demonstrated, there is a clear solution to the problems presented by the density in BCHOC: namely, releasing detainees as determined to be appropriate through individual applications for bail. As this Court has noted, all of the class members are civil immigration detainees who, but for their immigration status, would not be confined. And with release from BCHOC, such individuals are all still under the Court’s and ICE’s control, self-quarantining and serving home detention, many now with electronic monitoring in ICE’s discretion. *See* ECF 64, Memorandum and Order at 9 n.6 (detailing Court’s conditions on release). Critically, however, they are no longer being held in the unreasonably unsafe congregate conditions at BCHOC that greatly heightens their risk of infection. ECF 64, Memorandum and Order at 22 (“Since COVID-19 is highly contagious and the quarters are close, the Detainees’ chances of infection are great.”). The orderly and workable process that the

Court has set up to consider individual applications for bail should continue apace, to alleviate the “substantial risk’ of harm” that currently exists for class members detained at BCHOC. *Id.* at 12.

Respectfully Submitted,

/s/ Oren Sellstrom
Oren Nimni (BBO #691821)
Oren Sellstrom (BBO #569045)
Lauren Sampson (BBO #704319)
Ivan Espinoza-Madrigal†
Lawyers for Civil Rights
61 Batterymarch Street, 5th Floor
Boston, MA 02110
(617) 988-0606
onimni@lawyersforcivilrights.org

Grace Choi, Law Student Intern*
Kayla Crowell, Law Student Intern*
Laura Kokotailo, Law Student Intern*
Aseem Mehta, Law Student Intern*
Alden Pinkham, Law Student Intern*
Bianca Rey, Law Student Intern*
Megan Yan, Law Student Intern*
Reena Parikh†
Michael Wishnie (BBO# 568654)
Jerome N. Frank Legal Services Organization
P.O. Box 209090
New Haven, CT 06520
Phone: (203) 432-4800
michael.wishnie@ylsclinics.org

† Admitted *pro hac vice*.

* Motion for law student appearances pending.

CERTIFICATE OF SERVICE

I hereby certify that, on April 16, 2020 a copy of the foregoing document was filed electronically and served by mail on anyone unable to accept electronic filing. Notice of this filing will be sent by email to all parties by operation of this court's electronic filing system or by mail to anyone unable to accept electronic filing as indicated on the Notice of Electronic Filing. Parties may access this filing through the court's CM/ECF system.

Date: April 16, 2020

/s/ Oren Sellstrom
Oren Sellstrom (BBO #569045)