

The Rise of the Anti-clockwise Newel Stair



Newark Castle. Gatehouse, c. 1130-40. The wide anticlockwise spiral stair rising to the audience chamber over gatehouse passage.

The Rise of the Anti-clockwise Newel Stair

The Rise of the Anticlockwise Newel Stair

Abstract:

The traditional castle story dictates that all winding, newel, turnpike or spiral staircases in medieval great towers, keep-gatehouses, tower houses and mural wall towers ascended clockwise. This orthodoxy has it that it offered a real functional military advantage to the defender; a persistent theory that those defending the stair from above had the greatest space in which to use their right-handed sword arm. Conversely, attackers mounting an upward assault in a clockwise or right-handed stair rotation would not have unfettered use of their weaponry or have good visibility of their intended victim, as their right sword hand would be too close to the central newel.

Whilst there may be other good reasons for clockwise (CW) stairs, the oft-repeated thesis supporting a military determinism for clockwise stairs is here challenged. The paper presents a corpus of more than 85 examples of anticlockwise (ACW) spiral stairs found in medieval castles in England and Wales dating from the 1070s through to the 1500s. Whilst admittedly scarce in the Norman period (1070-1200), they rise in popularity from about the 1240s, especially with the introduction of the twin-towered gatehouse, see regular use in the Edwardian castles of the late-13th century in towers of all kinds, and are used consistently and more frequently thereafter.

The paper examines the functional, stylistic and aesthetic reasons for these changes, their general architectural and constructional development, from wide-vaulted stone staircases, to simple one-piece stone cut-slabs (winders) that fitted into both the containing wall and formed part of the central newel, and the later brick vaults and brick stairs. The European origins of the spiral stair are discussed by way of introduction, and the earliest examples of each technical or stylistic development are pinpointed.

The spiral staircase, as well as being wholly functional, could be a significant architectural device, and was used, like the straight stair at Castle Rising, to heighten grandeur, monumentality and theatrical drama. It was also used to display wealth, and to demonstrate the patron's knowledge and awareness of stylistic advances and innovative aesthetic features. They are an enduring domestic feature that still find a place in today's cutting edge architectural armoury.

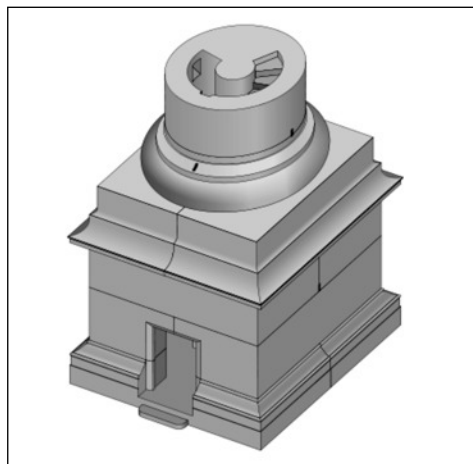

Fig. 1. Diagrammatic view of Trajan's Column, Rome, AD 130, viewed from the east. The interior anticlockwise (ACW) stair made from solid marble blocks.

Origins and Definitions.

The spiral, also known as a vice, helix, helical, winding, turnpike, or circular stair is an ancient device, and existing anticlockwise (or counter-clockwise) examples are found, for example, in Trajan's column, Rome (AD 130) which contains an ACW stair built out of solid marble inside the core of the column. (fig. 1), and in the palace of retired Roman Emperor Diocletian, at Spalato (Split, Croatia) (circa AD 300).¹ Justinian's famous iconic octagonal basilica of San Vitale at Ravenna, (AD 526-547), one of the most important examples of early Christian Byzantine art and architecture in western Europe, used the spiral or helix, and represents one of the earliest appearances of a specially designed forebuilding or narthex that included symmetrical pairs of spiral stairs, one CW and one ACW (since destroyed) (fig. 2).

Charlemagne's Palatine Chapel at Aachen (AD 793-805) (fig. 3) is widely regarded to be closely and deliberately modelled on San Vitale - he visited Ravenna three times. This also has mirrored pairs of spiral stairs, the north turret ACW, and south CW. Whilst the Palatine Chapel is inspired by San Vitale in Ravenna, there is here a tall twin-towered monumental western entrance complex, as a whole called a 'westwork' - a fea-

¹ The 'spiral' is also variously described as an elliptical stair, geometric stair, turret stair, well stair, turnpike, corkscrew, and *ascensorium*, *cochleae*, *turnegreis*; *l'escalier en vis*, vis de St Gilles, St Gilles screw.

The Rise of the Anti-clockwise Newel Stair - The 11th century

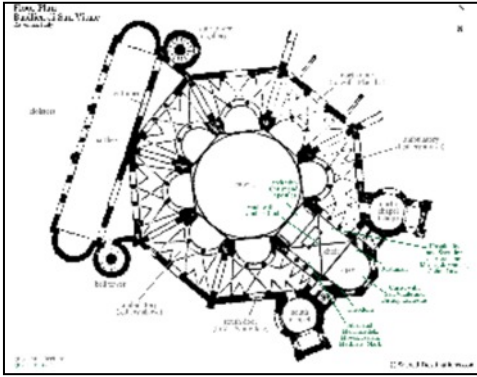

Fig 2. Original plan of San Vitale, Ravenna. The narthex, top left, has since been destroyed, but the north stair turret, leading to the gallery, remains.

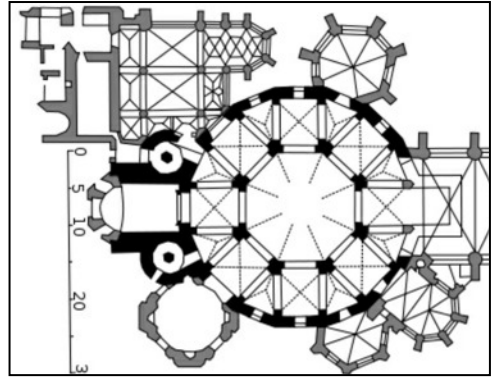

Fig 3. Charlemagne's Palatine Chapel, Aachen. The paired spiral stairs adjacent to the west entrance, with the ACW stairs in the north turret.

ture introduced in the Carolingian era. Carolingian churches generally are basilican, like the Early Christian churches of Rome, and commonly incorporated westwork, which is arguably the precedent for the western façades of later medieval cathedrals.

The Romanesque and Gothic cathedrals of late 11th - 13th century England continued this practice, and many of the spiral stairs in both the north and south transepts and the later 'westwork' towers often have mirrored opposites - CW and ACW stairs, but there appears to be no written rule that states ACW stairs should be placed to the north and CW to the south or *vice versa*. Examples of cathedral spirals include St Albans, c.1077 (transepts, mirrored CW/ACW [north]); Lincoln (westwork CW/ACW mirrors); Rochester (1 x ACW, central crossing); Durham (both transept and westwork CW/ACW mirrors), Hereford (N transept ACW); Canterbury (easternmost transept, CW/ACW mirrors) Ely (ACW, south tower at the westwork); Winchester (transept mirrors CW/ACW); Norwich (transept mirrors CW/ACW, ACW westwork, south tower),¹ Lindisfarne Priory (westwork, CW/ACW c. 1130). There are sufficient examples to illustrate that patron clerics and their master masons were well aware of a tradition of clockwise and anti-clockwise symmetry, although there may have been functional or practical reasons for the matching opposites - for exam-

¹ A few late-medieval parish churches are similarly equipped with anticlockwise stairs - Llangwm Uchaf, Gwent; Cardiff, St John; Shropshire: Ludlow central tower circa 1460-70; Shifnal porch 13th century; Gloucestershire: Bishops Cleeve, west front; Tewkesbury transept.

ple, assisting human traffic flows, as cathedral spirals are notoriously narrow and rarely allow for two people passing on the stairs. This may have resulted in *ad hoc* one way systems. Or there may have been architectural considerations in determining how to maximize the best sources of light. The ecclesiastical tradition of internal vaulted stone spiral staircases within a confined cylindrical casing was imported and emulated by the Norman ruling elite and used extensively when developing their network of great rectangular keeps or great towers, initiated by William the Conqueror.² They are first seen, on a monumental scale, at the White Tower (1070s-1100), Colchester (1070s-1120), Norwich (1095-1115), and Corfe (possibly as early as 1080-1105), followed by Canterbury, Rochester, Kenilworth, Portchester, Bamburgh, Castle Rising, Hedingham, Dover, Carrickfergus and many other great towers of the Henry I and Henry II era up to the 1190s.³

² Note that the spiral stone staircase is recorded as having been in use in Britain from the 8th century, with a number of Anglo-Saxon single examples attached to the exterior of western church towers from at least the 10th century. Examples include: Hexham; St Andrews, Weavertorpe; St Andrews, Brigstock, Northants; All Saints, Brixworth, Northants; Broughton by Brigg, Lincs; Hough on the Hill, Lincs; possibly Wimborne Minster, Dorset. See Fisher, 1962; H. Taylor and J. Taylor, *Anglo-Saxon Architecture*, 1965; Braun, 1985, pp. 257-81.

³ An alphabetic list of over 90 Norman Romanesque and Angevin stone keeps/great towers is found in Thompson's *The Rise of the Castle*, pp. 64-65. There are arguably up to 30 others that once existed, including Coity, Ewloe, Lydney, Mileham, Radcot, St Briavels, Stone, Usk, Old Walmer, and Whittington.

The Rise of the Anti-clockwise Newel Stair - The 11th century



Fig. 4. The White Tower, c. 1070-1100. The principal NE staircase turret - appearing polygonal to the lower exterior and circular to the top.

Why is the vice or spiral stair such an appealing design for elite secular buildings? Because it is compact, efficient, and occupies less floor space than other arrangements, vital in planning when space was at a premium. Every square metre of internal space demanded a heavy financial investment in external perimeter walling, and their provision was a compromise between expense, convenience and security, particularly in rectilinear great towers, where the cylindrical shaft was unobtrusively located in the thickness of the walls, positioned, usually, in widened corner buttresses, a feature synonymous with Norman and Angevin great towers. These buttresses could be a massive four to six metres thick (e.g. Colchester, Hedingham, Middleham) allowing for a principal staircase cylinder of up to 3.7m in diameter (Orford, 1172), 4.25 m. diameter (Hedingham, 1140) and 5.0m, diameter (Colchester), responding to the power, wealth or *puissance* of the owner, and sufficiently wide for two persons to walk up abreast, which may have been a factor when planning royal castle-palaces.¹ The treads or winders here are normally about 1.4 to 1.9 metres wide (with Colchester exceptionally 2.15m).

¹ Appendix 1 has fuller details of all stair dimensions.

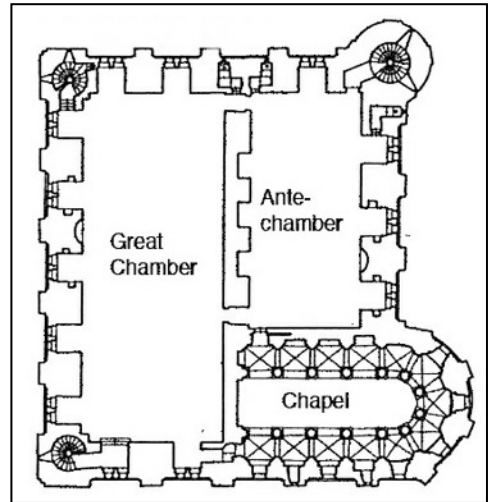

Fig. 5. The White Tower. Upper (second) floor plan showing the ACW stair in the NW corner.

The White Tower - London.

The earliest Norman secular building that contains a combination of both clockwise and anticlockwise spiral stairs is, not unsurprisingly, the White Tower within the Tower of London complex, which was commenced in the late 1070s. The imposing principal spiral clockwise (CW) staircase is in the NE corner - 3.6m. cylinder diameter - 1.4m tread width, 20 cms riser height (figs. 4-8). This is a dedicated, articulated, staircase turret, protruding like an ear, that rises through every floor from the basement, with access at each level. It is a cylindrical turret, but the four external pilasters create the impression of a polygon. Significantly it is placed in the diagonally opposite corner to the SW entrance, but not all great towers follow this awkward configuration - many later locate their principal internal staircase more conveniently near the entrance. A further clockwise spiral stair starts from the upper-floor level in the SW corner giving access to the gallery level only (fig. 5). At the same upper-floor level is one anticlockwise (ACW) stair starting in the NW corner, rising to the roof battlements (figs. 7, 8). This may not have been included in the plan until 1080. This NW corner buttress is smaller than the purpose-designed NE staircase corner turret, and the vaulted spiral is correspondingly smaller in diameter (winder width 1.21m, riser height 20cm). This is a service rather than a ceremonial stair and which often led to more private internal space.

The Rise of the Anti-clockwise Newel Stair - The 11th century



Fig. 6. The White Tower. Upper floor showing the start of the principal vaulted CW stair in the NE corner.

The principal NE stair at the White Tower is spaciouly and grandly conceived; wide, tall and stately (fig. 6). In some great towers one had to occasionally cross to the far end of the hall or lower chamber to access the continuation of the spiral stair to the upper floors. This has often been attributed to being a defensive design feature, but it lacks plausibility. Considerations of privacy and propriety must have weighed more heavily, all the more as the possibility of prolonging a defence of a position by holding a narrow winding stair, equally awkward for both parties, does not seem to have a place in the Norman medieval mind. For them the game obviously was up before that stage could be reached. The approach to the more private apartments was normally from the *dais* or high end of the hall - the private end - and this was usually the reason why a diagonally opposite stair was so positioned, conveniently placed to retire to more private suites.¹ Sometimes spiral stairs rising through all floors do not have access to the levels where privacy was required. In all this, there is still no obvious desire to give newel shafts or entry lobbies to them any conspicuous decorative character.

¹ See W. Mackay Mackenzie, 1927, pp. 127-9, who eloquently makes this point.



Above: Fig. 7. Upper floor access showing the secondary anticlockwise ACW stair in the NW corner.

Below: Fig. 8. Entrance lobby in the enlarged window recess, leading to the ACW stair in the NW corner turret, Upper (or first) floor.



The Rise of the Anti-clockwise Newel Stair - The 11th century

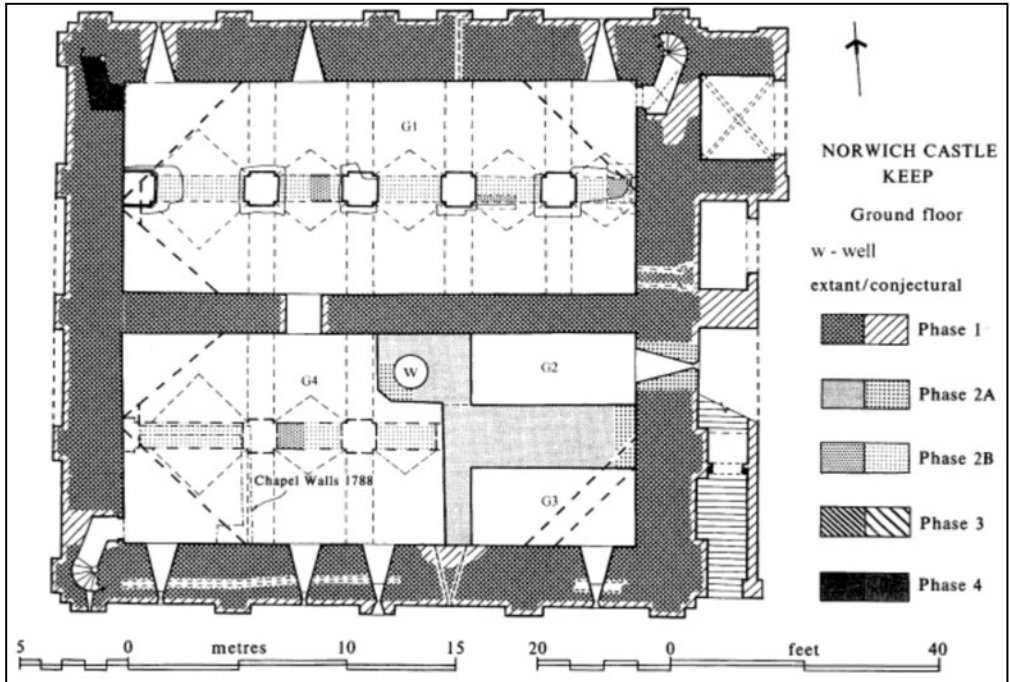

Fig. 9. Ground floor (basement) plan of Norwich Castle. Anticlockwise- ACW - spiral stairs in both the NE and SW corners. Aborted CW stair in the NW corner buttress. If completed it would have created two sets of symmetrical mirrored opposites. Plan reproduced courtesy of Paul Drury.

Norwich Castle great tower - Norfolk

After the White Tower and Colchester, the Norwich Castle *donjon* is the third in a line of a distinguished group of royal castle-palaces, probably begun in the 1090s, and completed, after a break, in the 1110s. It is among the largest, most elaborate and yet perhaps the least well known of the great Romanesque *donjons* (sometimes referred to as hall-keeps) in Europe. Unfortunately much of the interior of the great tower at Norwich has been gutted, and there has been considerable scholarly debate over the last twenty years over the original internal plan at various floor levels.¹ However, the intentions of the builders for placing spiral stairs in three of the very modestly-sized corner buttresses (NE, NW and SW - the same as the White Tower) are clear from the start. Norwich lacks the substantial bulky projections at the cor-

¹ See T. A. Heslop, *Norwich Castle Keep*, 1994. For the debate see P. J. Drury, 'Norwich Castle Keep'; and P. Dixon and P. Marshall, 'Norwich Castle and its Analogues', in *The Seigneurial Residence in Western Europe. AD c.800-1600*, (eds) G Merion-Jones, E. Impey and M. Jones, British Archaeological Reports International Series 1088, Oxford, 2002, pp. 211-24 and 235-43 respectively. Note also Goodall, 2011, pp. 112-13.

ners which at the White Tower and Colchester supported corner turrets that continued up to project well above the height of the main battlemented walls. The NW clockwise spiral stair was later blocked and the corner internally modified to receive an oven in Phase 4, but the extant NE and SW corner spiral stairs both start from the basement and rise to roof level. (figs. 9-11).

Unusually, both of these vaulted stairs ascend anticlockwise. The ground-floor dimensions are: NE stair: winder width 0.86m; riser height: 20 cms. SW stair: winder width: 0.86m, riser height 20cms. At first-floor level both the newel diameters narrow and the stairs widen to 0.97m. These sizes are circumscribed by the rather narrow buttress and wall thickness dimensions established in the 1090s, but are mitigated by the interior corner bulges within the keep. The aborted NW stair rises from the ground floor with a slightly wider stair width of 0.97m. As Norwich was probably the first royal tower to include a grand integral stone forebuilding with a straight grand stair leading up to the principal floor, it may have been concluded that the principal spiral stairs need not be so commodious or spectacular in themselves as they

The Rise of the Anti-clockwise Newel Stair - The 11th century



Fig. 10. Norwich Castle. ACW anticlockwise stair in the NE corner buttress. As seen here, the solid newel drums reduce in diameter when the spiral reaches the first floor level (fifth stair from top right).

were now assuming a subsidiary role. This guiding rule may have been repeated at other Norman great towers where forebuildings had been planned from the start.¹ However, forebuildings were sometimes later additions, (Hedingham), and some are destroyed (Corfe, but the lower level remains; Guildford, Kenilworth), so assumptions can easily be skewed. Dover, with a grand forebuilding planned integrally also contains the second widest winders (1.9m) in Britain. So any theory that one type of grand stair - the straight monumental stair, the '*escaliers grand degrés extérieur*' may have been a surrogate for the other - the internal spiral - does need further consideration. The castle-palace at Norwich was commenced by William II (Rufus, r. 1087-1100), a profligate man, yet with great architectural ambition, and continued under Henry I (r. 1100-35). He visited Norwich and stayed at the great tower on at least three occasions (1104, 1109, 1121). Notably, Norwich cathedral has a CW/ACW mirrored pair of spirals in the transepts and mirrors the castle architecturally in decoration and many other ways.

¹ Corfe, Castle Rising, Kenilworth, Rochester, Sherborne, Scarborough, Bungay, Brougham, Bowes, Newcastle upon Tyne, Dover and others.



Fig. 11. Norwich Castle. ACW stair in the SE corner buttress at ground floor level. Stair treads here are modern replacements but some originals do exist.

The Rise of the Anti-clockwise Newel Stair - The 12th century

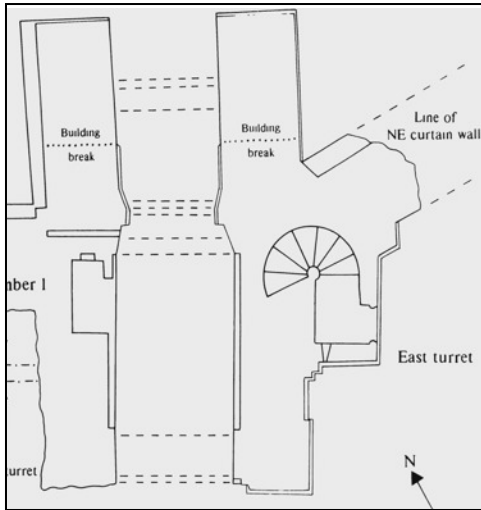

Fig 12. Newark Castle, gatehouse plan, c. 1130-40. ACW spiral staircase entrance to the east, after Samuels and Marshall. 1997.

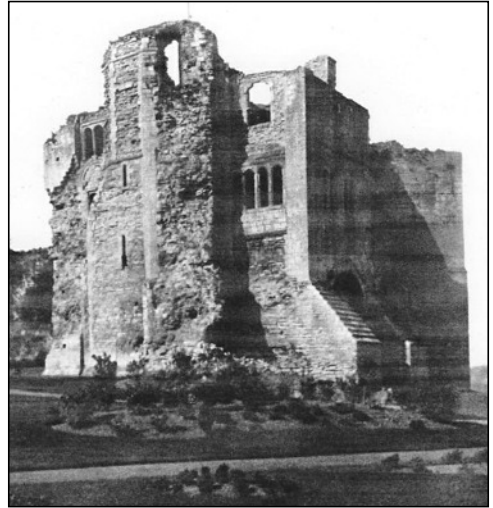

Fig. 13. Newark Castle, gatehouse. Detail from the Francis Frith photograph dated 1895 (24650), taken before the lower section of the staircase turret was rebuilt.

Newark on Trent Castle, Nottingham

Newark is a remarkable castle, and Bishop Alexander's gatehouse is one of the finest to survive from the early 12th century. Alexander was the nephew of Bishop Roger of Salisbury (d. 1139), who finished his life as one of the most powerful and richest men in the kingdom, having been made Chancellor by Henry I. Roger built castles at Old Sarum, Devizes, Malmesbury, Kidwelly and Sherborne, and founded an ecclesiastical dynasty, with nephews Alexander, Bishop of Lincoln, and Nigel, Bishop of Ely. At Newark, Alexander, in 1130-40, set out to create an ecclesiastical castle-palace, and his work that remains (which is only about 20%), primarily the gatehouse, is very similar to Roger's high quality work at Sherborne Castle, visited by the CSG in April 2010. It was said of Roger's work that:

'he erected edifices at great cost, and with surpassing beauty, the courses of stone being so correctly laid that the joints deceive the eye and leads it to imagine that the whole wall is composed of a single block' (William of Malmesbury (1095-1143), *Gesta Regum*).

The same could be said of Newark. Bishop Roger and Alexander's work is singular in materials, style and plan and it may have been Roger's various offices and experiences as a cleric that produced his underivative approach to castle design, a very different cast of mind to that of most barons. Like the NE corner of the White Tower,

Newark gatehouse incorporated a staircase turret integrated from the start as part of the main body of the entrance block, but with a ground-floor bailey entrance and an elegant, wide, spiral anti-clockwise ceremonial stair with a 1.57m winder width, and riser height of 21 cm, or 9 in. - almost the same in all respects as the White Tower example. It leads to the audience chamber over the entrance passage on the first floor, and then narrows slightly further up to the wall walk.¹ A relatively undefended ground-floor entrance at this time is extraordinary, challenging the usual conventions of Norman military defensive planning (figs. 12-17).² The Sherborne gatehouse had a similar arrangement and it is possible that the staircase also climbed anticlockwise. A further example of an anticlockwise spiral stair, also at Newark, is found adjacent to the narrow central tower along the west curtain wall that runs parallel to the River Trent. It is located in the area of the Great Hall. Access to the upper tower floors was from the ground-floor hall via an internal window recess to the south. The whole west curtain was built in the late 13th/ early 14th century, and this configuration is similar in concept to the Prison Tower at Conwy (also with an ACW stair). Today the upper spiral is looking precarious and is not accessible (fig. 53).

¹ Note fig. 13 and the caveats discussed under fig. 14.

² See Marshall and Samuels, 1997, pp. 22-25, and Dixon, Marshall, Palmer-Brown and Samuels, 1994.

The Rise of the Anti-clockwise Newel Stair - The 12th century



Figs. 14 & 15. Newark on Trent. The south and eastern façades of the 1130-40s gatehouse, showing the integral staircase turret, with its (rebuilt and re-faced post-1900) ground-floor entrance, giving access to a palatial audience chamber directly over the entrance passage, and access to the demolished eastern wall walk at the top. Unusually, the staircase winds ACW. The current east entrance and immediate stonework on its south side is post-1900, and the stair-turret entrance may well have been to the south originally, with the south wall-face running vertically straight to the ground without the final outward offset. See the Francis Frith photographs: 24651, 24650 - Fig 13, 35553 and 35552. Inset: Fig. 15. A section of the vaulted roof of the Newark spiral, showing the gradual segments of vaulting with the impressions left by the progression of the timber centering.

The Rise of the Anti-clockwise Newel Stair - The 12th century



Figs. 16 & 17. North, entrance façade to the Newark gatehouse, with the stair turret to its left. Windows are later insertions. Below, left: Fig 17, Inset: The wide ACW spiral stairs, 1.57 metres width, the winders (part renewed stone) resting on vaulting and butting up to the newel- not part of it. The newel consists of stacked single-piece ashlar drums (like Norwich).

The Rise of the Anti-clockwise Newel Stair - The 12th century

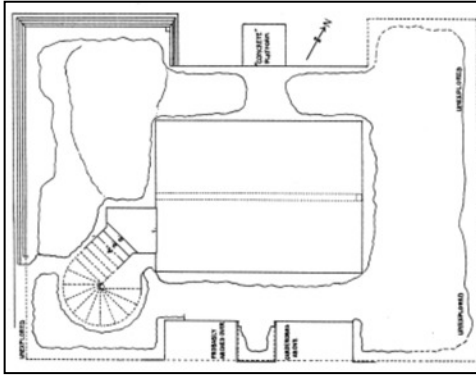

Fig 18. Brandon Castle, great tower plan, c. 1130. ACW rising stair in the SW corner. After Chatwin, 1955.

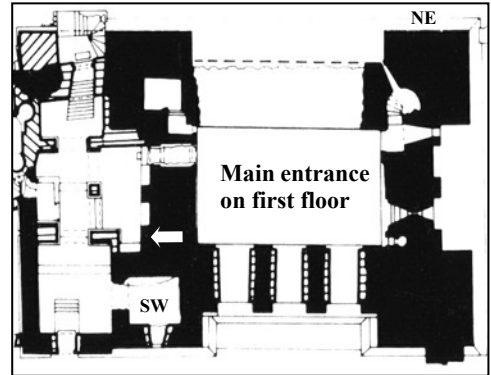

Fig. 19. Kenilworth Castle, great tower, c. 1130. CW rising stair in the NE corner.

Brandon and Kenilworth Castles, Warks.

Brandon, built by Geoffrey de Clinton *circa* 1125-35, probably contemporaneously with Clinton's other great foundation, the great tower at Kenilworth Castle, was once a great tower of immense proportions.¹ Overall, the Brandon tower is a rectangle of about 17m. x 13m., just over half the size (by area) of Kenilworth (24m. x 18m) - (by comparison, the White Tower is 32m. x 36 m.), but maintaining a remarkable similarity to its ground-plan except that the SW stair rose anti-clockwise. It was apparently destroyed in c.1266, having been captured by the Kenilworth garrison in a surprise sortie and burnt and does not ever appear to have been restored. The ruins, on plan at least, showed a putative ACW ascending staircase when excavated in the late 1940s, with a winder width of 1.38m (figs. 18, 20, 21). Distinctive are the massive corner buttress turrets and deeply stepped moulded plinths of both castles, along with their strongly profiled centralised, or inter-

mediate pilasters. Brandon also stands in the low-lying watery plains of the River Avon and extensive moats are fed by this river, best seen in the winter. The topography is therefore also similar to Kenilworth.

A large, shattered, vaulted clockwise spiral staircase remains in the NE turret at Kenilworth, with a cylinder diameter of 3 metres, and a winder width of approximately 1.37m. The newel and the winders are broken away and it is no longer accessible. The spiral rose from the basement or ground floor and continued to the wall walk, with access from the main upper floor (figs. 19, 22-23). The ground floor was entered independently through a passage off (or perhaps behind) the original forebuilding and just south of the NW corner tower. How the forebuilding and external stairs were configured to access the principal floor will be the subject of another paper about 12th century forebuildings.² Kenilworth does contain anticlockwise stairs in four other locations: Lunn's Tower, the Water Tower, the Saintlowe Tower, and the Strong Tower. These are all fourteenth century stairs and are dealt with in a later section. Robert Dudley gutted the interior of the SW corner turret and installed a timber open-well square newel type in 1569-70³ - since removed.

¹ See John Goodall, 2011, pp. 100-101, and P. B. Chatwin, 'Brandon Castle, Warwickshire,' *Birmingham Archaeological Society Proceedings and Transactions*, 73, (1955), 63-83. Also note the English Heritage *Kenilworth* guidebook, 2010 by Richard K. Morris (ed.), pp. 35-36, which states: 'Brandon Castle provides an important clue that the keep at Kenilworth should be attributed to the de Clinton patronage. Its distinctive plan, with projecting angle turrets and prominent intermediate buttresses is reflected on a smaller scale in the stone keep at Brandon. No independent dating evidence survives for Brandon, but a castle was in evidence there by the time Geoffrey II married Agnes of Warwick, and it would be surprising if keeps of related design, in two castles possessed by Geoffrey I were not both commissioned during his lifetime'.

² It remains unclear just how the forebuilding was configured especially if it is assumed that the stair up to the forebuilding started from the Inner Ward. No 'artist's impressions' have been attempted by English Heritage.

³ See Richard K Morris, 'I was never more in love with an olde house nor never newe work coude be better bestowed': The Earl of Leicester's remodelling of Kenilworth Castle for Queen Elizabeth I., *The Antiquaries Journal*, 89 (2009), pp. 241-305, especially. p. 259.

The Rise of the Anti-clockwise Newel Stair - The 12th century



Fig. 20. Above. Brandon Castle. A previously unpublished photograph of the excavation of Brandon castle in 1948. In the picture the excavator, John Edwards, is seen in front of the buttressed W corner of the tower. The stonework is beautifully worked ashlar and some of the pieces are truly monolithic. The mouldings of the plinth are comparable with Bamburgh (1130s). Working on site at the time was a youthful Anthony Emery who arranged for this picture to be taken, and in whose archive it remains. The image is reproduced courtesy of and ©Anthony Emery.

Fig. 21. Right. Brandon Castle today, from the south. The stonework remains buried and the field is a paddock.



The Rise of the Anti-clockwise Newel Stair - The 12th century



Fig 22. Above: Kenilworth Castle. The great tower, c. 1125-30, from the south. Fig. 23. Below: The great tower from the east. The NE staircase turret to the north (right). Small slit loops in the chamfered angle lit the spiral stair.



The Rise of the Anti-clockwise Newel Stair - The 12th century



Fig. 24. Goodrich Castle from the south. The great tower, c. 1148, centre, within the courtyard of the later quadrangular castle and behind an 'en bec' enceinte.

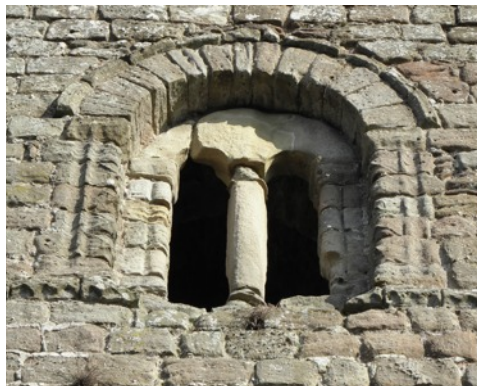

Fig. 25. Goodrich Castle. The two-light window on the second storey of the great tower, west façade. (The south façade, facing the 'field' is windowless).

Goodrich Castle, Hereford

Goodrich is probably the smallest Norman castle keep or great tower in Britain, measuring 4.27m square (14ft x 14ft) internally, and 16m (52.5ft) in surviving height (figs. 24-28).¹ Its ashlar-faced walls are 2.2m thick with narrow clasping pilaster buttresses at the corners. The tower was probably built c. 1148-52 in the time of Richard 'Strongbow' de Clare's ownership. Several architectural features indicate this probable date, including the fine two-light windows facing north and west at the upper level (figs. 25, 27). Both are decorated with typical Romanesque chevron or zig-zag ornament of the period.²

The current tower entrance is via the basement, or cellar, entered directly from the courtyard, the doorway being inserted in the 14th or 15th century. Access to the first floor (perhaps the hall) is by the use of a modern wooden stair within. The spiral staircase rises from the first floor hall to a private chamber and is tightly fitted into the north-west corner buttress (fig. 28). The ACW staircase is both extremely steep and nar-

¹ The footprint of the original tower keep at Llantilio (White) Castle (demolished) indicates this was dimensionally just slightly larger. The Goodrich dimensions are from the photogrammetric survey by the IAAS (York) for the forthcoming two volume study by the City of Hereford Archaeology Unit.

² See the *Goodrich Castle Guidebook* by Jeremy Ashbee, English Heritage, 2005. The otherwise excellent guidebook and plan does not show the spiral staircase in the keep. The plan, of course, is a ground-floor plan, so naturally the spiral stair is omitted, but there is a case for showing a plan of each floor of the keep, as has been done with the later period south-west tower.



Fig. 26. Goodrich Castle. The start of the vaulted ACW stair in the NW corner buttress.

row. In fact, it is so inhospitable that one has to question the ultimate purpose of the tower. (Thompson describes it as a solar keep, similar to, though smaller, than Farnham and Clitheroe). The staircase rises from the hall to the grandest room in the tower, perhaps the solar, and continues to the present roof level, but the narrowness of the stair makes it an awkward climb. The step or riser height is the Norman (unwritten) regulation 20 to 21 cms. (7.88 to 8.25in.), a remarkably consistent height throughout the 12-15th century, and the tread/winder width is 0.70m, the narrowest known for this period (figs. 26, 28).

The Rise of the Anti-clockwise Newel Stair - The 12th century



Fig. 27. Goodrich Castle, the donjon c. 1148-52. The ACW spiral starts on the first floor - at the level of the converted north-facing doorway (into a window) above the present basement entrance, and continues to the top in one continuous run. The two loops on the right of the tower near the clasping corner buttress indicate its location.

The Rise of the Anti-clockwise Newel Stair - The 12th century



Fig. 28. Goodrich Castle. The Norman donjon, c. 1148-52. The precipitous spiral stair in the NW corner buttress, rising from the first floor to the roof. Vaulted, with steeply rising treads. Riser height 21 cms (8.5 in.), tread width 0.7m. (cf. Colchester 2.15m). Whilst current UK building regulations allow a riser height of between 17 and 22 cms, the regulations recommend builders should stay ideally between a range between 19 and 21 cms to build a flight that is most comfortable in use. (Building Regulations 2000, Section 1, Stairs and Ladders, Part K, K1, paras 1.1-1.6)

The Rise of the Anti-clockwise Newel Stair - The 12th century - Summary



Fig. 29. Appleby Castle. The great tower, c. 1157-1170. Present battlements and turrets later.

Appleby Castle.

A stone great tower (Caesar's Tower) of the third quarter of the 12th century, it was probably raised by Hugh de Morville, (d. 1173/4), who held the castle as a royal (Henry II) appointee between 1157 and 1171. It should perhaps be dated to the 1157-1160s by Royal subvention.¹ It was constructed without a stone forebuilding and originally comprised two floors set over a basement, but later heightened.² The south façade and plan of the second and third floors indicate mirrored spiral stairs in both corner buttresses in the SW and SE turrets. The ACW SE corner stair rises through all three levels (left of the entrance with three lower lights). The SW spiral only links the floors above ground floor level. The tower is, regrettably, not currently available for inspection (figs. 29, 30).

The Norman Period - Summary

Examples of Norman anticlockwise spiral stairs are sparse (7), with the ratio of castles with CW to ACW stairs about 20:1.³ See *Table 1*. Vaulted clockwise principal spiral stairs were the norm both in great towers from 1070-1200, and other domestic halls, including Christchurch and Burton Agnes, but Eynsford may have had an ACW stair from basement to first floor. In view of the fact that the ratio of CW to ACW stairs in cathedrals is probably 3:2 the greater propensity to construct great towers with clockwise stairs might indicate that they represented some additional form of defensive security. But it is unlikely. The great width or radius of the winders of many of the

¹ Goodall, 2011, pp. 135-138.

² The castle is privately owned, and is currently not open to the public. It is a building 'at risk' according to English Heritage, with priority 'D'.

³ Data taken from about 110 stone towers in England.

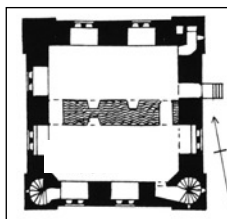

Fig. 30. Appleby Castle. The keep, c. 1157-70. Upper floor. After RCHM Westmorland, 1936.

highest-status stair turrets indicates that security was not likely to be a determinant. It was more to do with grandness and ceremony. At a practical, functional level, it seems easier for a right-handed person to ascend clockwise spirals. They have the widest part of the tread naturally on the left, nearest the turret wall and light source; they can grip the rope handrail with their left hand, and carry heavy items with their free right hand.

Spiral stairs were stone-vaulted throughout the period, normally using thin stones placed on edge to form the vault.⁴ The steps were constructed with a tapering series of trapezoidal-shaped short stone blocks with mortar laid onto and supported by the underlying vault (fig. 31). The composite newels were either made up of a group of four or five curving blocks of ashlar mortared together (figs. 6, 7) or later, single, smaller circular blocks or ashlar drums unattached to the steps or winders, although there was sometimes a short stub projection from the newel forming the narrow end-stone of the wedge-shaped steps. The vaults were constructed using timber centering, which was moved slowly upwards as work progressed (fig. 15). The diameter of the stairwell could therefore be unrestricted, only limited by the thickness of the corner buttress of the building worked out at the design stage. The longer the steps/winders the higher the vault and deeper the outside tread/winder depth, leading to spacious, safer steps and more elegant approaches to the Great Hall (e.g. Dover, fig. 86). Occasionally the stair-turret was positioned midway along a great-tower wall, such as Bungay, 1170s and Scarborough (1160s), where, in the latter case, the wall on that side of the keep was substantially thicker than its opposite counterpart (fig 34-1). The construction method was skilled and the pace of build was slow.

The widest English spirals known are: Colchester (winder 2.15 metres, fig. 33-1), Middleham (c. 1170-80, winder 2.0m, fig. 34-2), and Dover, (1180-90, winder 1.9m, figs. 34-3, 80); the narrowest and steepest is Goodrich (1148-52, 0.7m, fig. 28). Other fine examples, include the White Tower, (figs. 4-8), Norwich (figs. 10, 11), Hedingham (fig. 33-3), Rochester (fig. 33-2), Orford (fig. 33-4), and Newark (fig. 17). See *Appendix 1* for fully tabulated dimension details.

⁴ Although Margaret Wood, 1965, p. 333, following Toy, 1939 pp. 206-7, and 1953, p. 254-5, suggested that the cut-slab winder was introduced in England at the end of the 12th century. Examples of the cut-slab type are elusive prior to about 1225, although there are some in France, and at Carrickfergus, Ireland - see Conclusions.

The Rise of the Anti-clockwise Newel Stair - The 12th century

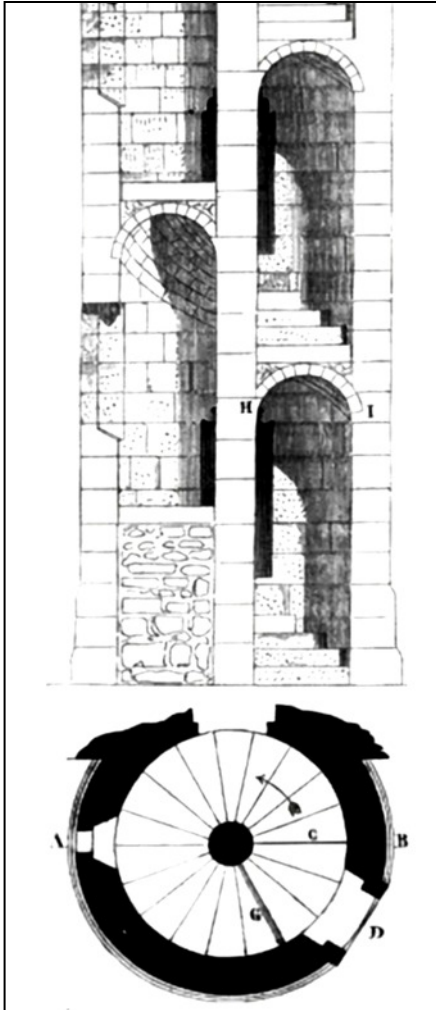

Fig. 31. Illustration of an anticlockwise vaulted spiral shaft similar to the Newark gatehouse turret.

The Violet-le-Duc illustration shows the plan and section along the line A-B of the plan. Stone-vaulted stairs were common in castles of the 11th and 12th centuries; the stairs are wider and the vaulted space higher; altogether a more airy and elegant experience, but not quite as elegant in English castles as the above example. The outer door of the staircase is marked D, the first ascending step C. The first few winders rest on a solid infill C-G; from this point starts the vault spiral depicted in section. The newels are a series of ashlar drums.

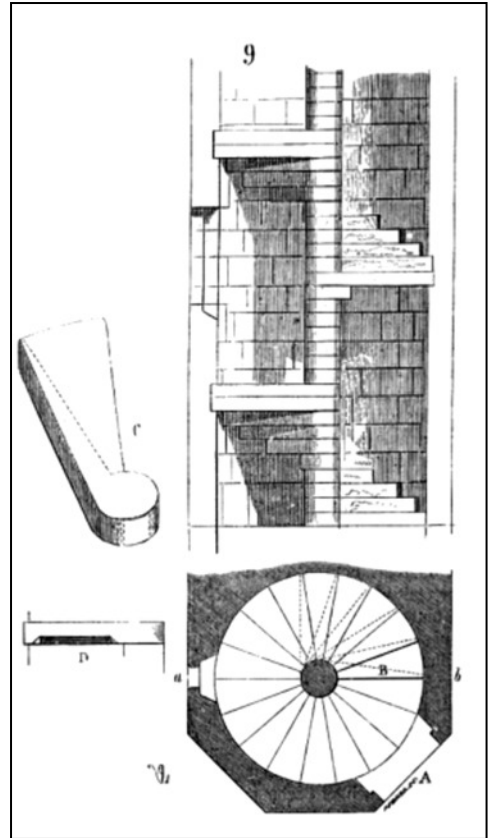

Fig 32. Illustration of the cut-slab embedded overlapping winders with an anticlockwise spiral stair rotation.

The Violet-le-Duc illustration above shows the plan and section of spiral stairs common both in France, England and Wales from at least the mid-13th century, for example at Dover, 1220s and Clifford's Tower, York, c. 1245-62. The outer door is marked A, the first step B. One-piece cut-slab winder overlaps are indicated by dotted lines, and C provides a detailed perspective of the tread steps, punctuated with the interlocking overlap of the next step. Sometimes, to facilitate the escape of water, the stairs are slot chamfered from below as seen in D. The newels are integral with the winder and are generally smaller in diameter than those seen in vaulted spiral staircases.

Both illustrations are taken from the *Dictionnaire raisonné de l'architecture française du XIe au XVIe siècle*, by Eugène Viollet-le-Duc, 1856. Vol. V, pp. 296-8.

The Rise of the Anti-clockwise Newel Stair - The 12th century

Examples of 11th & 12th century CW vaulted spiral stairs.



Fig. 33. 1: Colchester Great Tower - 1070s - CW (an 1890s print). 2: Rochester - 1130s, CW, NE turret, first floor. The newels have been robbed.. 3: Hedingham Great Tower - 1140s - CW. Original stone steps have been replaced by brick. 4: Orford Castle, 1160s, CW stair, at the top of the spiral with capital and centering imprints to the right.

The Rise of the Anti-clockwise Newel Stair - The 12th century

Examples of 12th century CW vaulted spiral and mural concentric stairs.

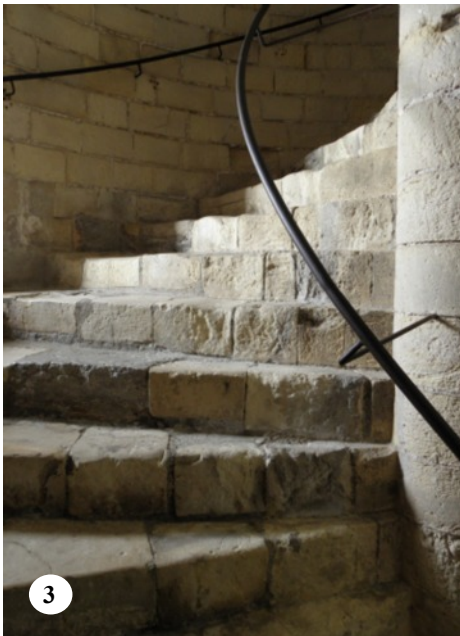

Fig. 34. 1: Scarborough Castle - 1160s - CW, stairs from the basement located in the middle of the wall. 2 Middleham Castle - 1170s - CW. 3: Dover Castle - 1180s - vaulted CW stairs - NE . 4: Conisbrough - 1190s - Mural CW.

The Rise of the Anti-clockwise Newel Stair - The 12th century



Fig. 35. White Castle, gatehouse, c. 1220-30s. With CW and ACW concentric mural stairs.

Round towers with concentric mural stairs.

Towards the end of the twelfth century a number of circular or polygonal great towers were built, including Conisbrough (figs. 34.4), by Hamelin Plantagenet in the 1180-90s; at Barnard, ‘*The Round Tower*’ by John de Balliol, c. 1195-1200¹; Orford 1165-73, (fig. 33.4) by Henry II; Tickhill 1179-82, Chilham, 1170, and Bronllys, c. 1221. The latter, and the first two mentioned included mural stairs that ran within the wall thickness concentrically along and inside the curve of the wall, with users having to cross the floor at each level to ascend to the next storey. Not here spiralling around a newel, but nonetheless an interesting short-lived development, with towers containing stairs part CW and part ACW. In these cases - Conisbrough, Barnard and Bronllys - the curving (or sometimes straight) concentric mural staircases are probably borrowings from the tradition of great tower architecture founded by Philip Augustus in the 1180s. Sequentially rising opposing floor to floor mural stairs were designed to mitigate and balance out wall weaknesses concentrated in one area rather than impede attackers. Closely allied to these was Hubert de Burgh’s four-storey twin-towered gatehouse at White Castle, probably c.1220-1230 or earlier (fig 35).² Here, both the NE and NW towers included concentric mural stairs similar to Conisbrough, but the NW tower was ACW and the NE CW. Both stairs were entered and accessible independently from the bailey at ground level.

¹ See Austin, 2007, Vol. I, pp. 166-171, 260.

² See J. K. Knight, *The Three Castles*, Cadw, 2009, pp. 40-42. Cadw’s preference is for a 1250s date for the gatehouse.

11th - 13th century English & Welsh Castles with Anticlockwise (ACW) Spiral Stairs

White Tower (1)	1080s. GT, V
Norwich (2)	1090-1110. GT, V.
Brandon (1)	1130s. GT, V
Newark, Notts. (1)	1130-40s. GH, V
Goodrich (1)	1150s. GT, V
Appleby (1)	1160s. GT, V
[Conisbrough (1)]	1180-1190. Mural
Framlingham (1)	1190-1200 (N Tower)
[Barnard (1)]	1195-1200. Mural
[White (1)]	1220-30. GH, Mural
Limerick (1)	1215 - SW Tower - V
Dover (1) Constable’s Gate.	1221-25s GH - CS
Dolbadarn. (1)	1230-40 to first floor
Tower of London (3)*	1238-1280s CS
Clifford’s Tower, York (1)	1245-62 Entrance-CS
Tonbridge (1)	1250-60s GH - CS
Pembroke (1)	1250s GH - V
Llansteffan (1)	1260s GH - CS
Caerphilly (4)	1268-72 GH - CS
Barnwell (3)	1260s Corner Towers
Flint (3)	1280s Corner Towers
Caernarfon (4)	1285 GH + 3 Towers
Conwy (1)	1287 GH - CS
Denbigh (1) Goblin Tower.	1290s
Beaumaris (4)	1295 GH + 3

* The Martin (1240), St Thomas’s (1275-9), and Byward Towers (1238-70).

GT=Great Tower, V=vaulted, CS=cut-slab, GH=gatehouse.

France - Some early examples of rectangular and round ‘*Tours Mâtresses*’ with Anticlockwise (ACW) Spiral Stairs.

Étampes, Paris	1130-50
Amblény, Aisne	1140s
L’Isleau, Charente-Maritime	1160s
Châtillon-Coligny, Loiret	1190
Châteaudun, Eure et Loire	1190s
Turenne, Limousin	1190s
Grand-Pressigny, Indre-et-Loire	1190s, CS
Gisors; Vexin	1196-1200
Narbonne, Languedoc	1200
Falaise, Calvados	1206
Coucy, Aisne	1220-30s, CS
Lillebonne, Normandy	1220s
La Rochelle, Charente	1220s

(38 Total E & W) **Table 1**

The Rise of the Anti-clockwise Newel Stair - The 13th century



Fig. 36. Dover Castle, Constable's Gate, 1221-27, one of the most elaborate gateways in England.

The 13th century and Henry III - (1207-72)

The embryonic gatehouse at White Castle appears to be coterminous with or perhaps even earlier than the more fully developed outer wall towers and gatehouse at Dover of the 1220-30s (e.g. the Constable's Gate), emulated at Beeston, Clifford (Herefordshire), Bolingbroke and Crickieth and ultimately the later gatehouses at Pembroke, Tonbridge and the Edwardian castles in Wales. Hubert de Burgh's experiences in defending (1216-17) and rebuilding the north Dover towers and gates (1221-27) and his earlier experiences in Normandy and the Loire may have contributed to his copying some of these features at White, Skenfrith, Grosmont and Hadleigh.¹

Dover - The Constable's Gate - 1221-27

In the north tower of the Constable's Gate complex at Dover, that is, the largest tower on the left of the arch (fig. 36, above), sometimes referred to as the Guardroom Tower, there is an anticlockwise spiral stair that ascends from the lower guardroom on the ground floor, to the upper guardroom and proceeds to the roof. This is of great interest as it may mark the earliest introduction of the one-piece cut-slab stair to an English

¹ See Knight, Jeremy, K., 'The Road to Harlech: aspects of some early thirteenth-century Welsh castles', in John R. Kenyon and Richard Avent (eds.), *Castles in Wales and the Marches: Essays in honour of D. J. Cathcart King*, pp. 75-88, esp. pp. 81-84.

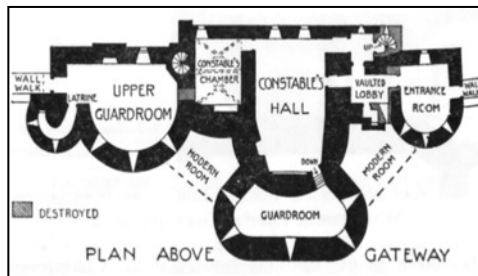

Fig. 37. Dover Castle, Constable's Gate, 1221-27. Plan, after Toy. The ACW spiral in the Upper Guardroom. Winder width: 0.8m; tread height: 20 cms.

castle. Currently the stair is not accessible to the public as it is still part of the accommodation for the ceremonial military post of the Deputy Constable and his staff. The staircase has been altered over the years and the treads have been boxed in with timber and carpeted; stonework is also heavily patched, plastered and all gloss-painted over making it difficult to ascertain its original form of construction. However, it appears to be the one-piece cut-slab type. Toy shows the staircase on plan (1966, p. 148), (fig. 37) in the SE corner of the D shaped tower, in the wall thickness, and giving access to the Constable's chamber, now hidden by a modern room that is carried over the flying arch. The hoodmould over the entrance appears to be original to the period, but the inverted volute stops could be a later addition (figs. 38.1, 2).

The Rise of the Anti-clockwise Newel Stair - The 13th century



Fig. 38.1 Castle, Constable's Tower. Hoodmould over the entrance to the ACW spiral stair with unusual spiral finial or volute stop (probably added later). The hoodmould might indicate that this was once an external door, later internalised in a second phase.

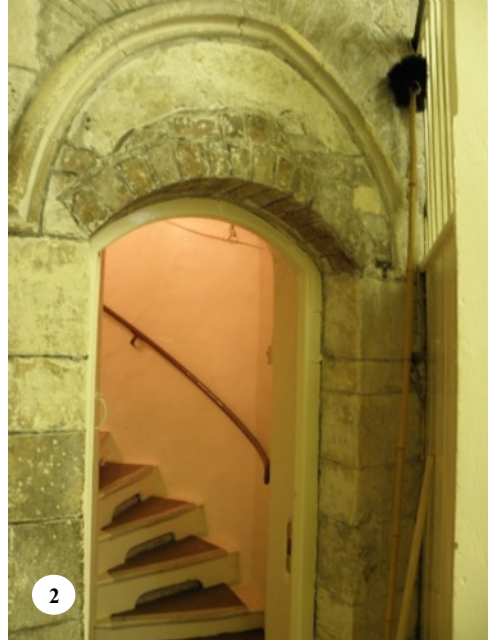

Fig. 38.2 Constable's Tower. Ground-floor entrance showing the tympanum below the hoodmould, perhaps formed due to lowering the architrave in a later period. The north tower is possibly a slightly later build phase added to the first phase core gatehouse tower.



Fig. 38.3. Constable's Tower. Blocked entrance off the stairs, to the Constable's Chamber on the first floor in the adjacent main block. (See Fig. 37).

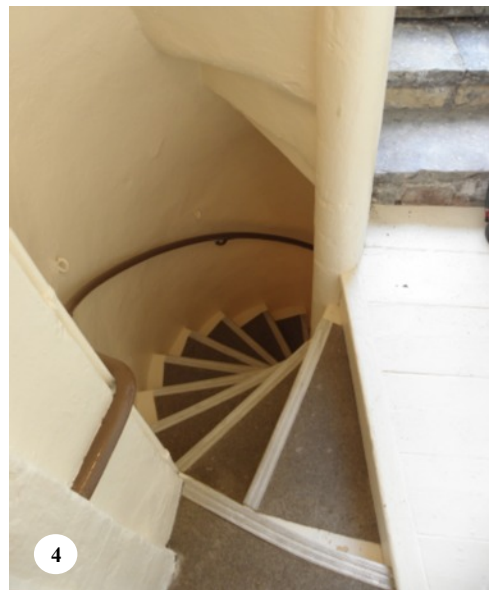

Fig. 38.4 Constable's Tower. The spiral stair at the top exiting onto the roof. The stair may have gone higher at one stage.

The Rise of the Anti-clockwise Newel Stair - The 13th century

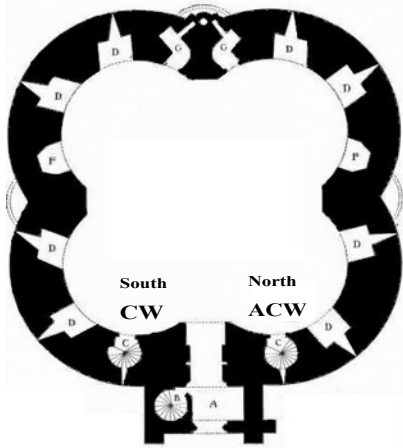

Fig. 39. Clifford's Tower. Ground-floor plan highlighting mirrored pairs of spiral stairs either side of the main entrance. The CW stair in the forebuilding is 17th century.

Clifford's Tower, York.

Clifford's Tower, York, c. 1245-62, built some twenty years later exemplifies more clearly both the architectural and technical advances that mark building practice at the time of the more elegant Henry III era (1216-1272). The tower is quadrilobate, of two storeys, but now remains a roofless shell. The walls of the tower are of magnesian limestone ashlar and the plan is similar to the towers of Amblény and Étampes (figs. 39-41).¹ Henry de Reynes, master mason and Master Simon, carpenter were despatched by the King in 1244/5 to view the castle and arrange how the tower should be built.² Henry de Reynes was to spend most of his later life involved in the rebuilding of Westminster Abbey and was one of the initiators of the English derivation of the Gothic French Court style. The style can be seen in the windows, and blind arcading at Clifford's Tower, and the paired/mirrored CW/ACW spiral stairs may have been introduced by Henry de Reynes³ from either custom and practice of cathedral design, aesthetic considerations, or in recognition of the need for a one-way system of traffic flows to the rooms over the entrance, where the mechanisms for the port-

¹ Although existing English castles such as Pontefract and Sandal (1240s) are equally source candidates.

² See *York Castle*, RCHM (England), 1973. For a reinterpretation of the tower see the EH Guidebook to Clifford's Tower by Jonathan Clark, 2010.

³ He may also have been responsible for some of the ACW stairs at the Tower of London, for example at the Martin and Byward towers c. 1270s.



Fig. 40. Above. Clifford's Tower - York. North ACW stairs. One-piece newel and winder. Many of the step's tops have been replaced/resurfaced. Tread height 20 cms. Fig. 41. Below: The ACW stair from the wall-walk.



cullis were housed. The spiral stairs at Clifford's Tower are an early example, perhaps one of the first in England,⁴ of one-piece cut-slab winders with the winders embedded into the turret cylinder wall for additional support. This eliminated the need for vaulting, and greatly accelerated the speed in building spiral staircases. The winder shortness (90cms. with a 20cms. riser height) might reflect a natural early caution with this innovation and their purely utilitarian, non-ceremonial requirements.

⁴ There are two early example in Scotland where the *donjon* spiral stair is built with one-piece cut-slab winders - Bothwell Castle c. 1242-90, where the *donjon* relates either to the initial early C13 Walter of Moray phase or that of his son William 'The Rich', and Dirleton c. 1240s by the de Vaux family. Both families were related by marriage to the Duke of Coucy .

The Rise of the Anti-clockwise Newel Stair - The 13th century



Fig. 42. Pembroke. Interior view of the Outer Gatehouse c. 1250, highlighting the mirrored and paired stair turrets either side of the (later) flying arch over the gatehouse passage.

‘Tonbridge style’ Keep-Gatehouses & Mirrored Stair Turrets.

The immediate precursor to the ‘Tonbridge style’ keep-gatehouses could well be the outer gatehouse at Pembroke, although recent well-reasoned but speculative comment offers a view that the Tonbridge gatehouse may have been building at about the same time - the 1250s - rather than the usual prevailing view that it is a product of the 1260s.¹ A comparison of the two suggests Tonbridge is head and shoulders above Pembroke in resources, finesse and planning. Pembroke and Tonbridge are part of a distinctive and impressive group of buildings that are singled out, amongst other features, by their paired staircase turrets facing towards the bailey, half or three-quarter round, and often placed at the angles of the outer corners (figs. 42-50). Their origins may be by way of the King’s works at the Tower of London, with master mason Robert of Beverly and others, and John Goodall argues that the specific source could have been the

¹ See Goodall, 2011, pp. 190-195 for a discussion of the ‘Tonbridge style’ gatehouses, and his view that the form was developed from Henry III’s building programme at the Tower of London. The Tonbridge gatehouse is also examined by Derek Renn who suggests a date of about 1265: ‘Tonbridge and Some Other Gatehouses’ in *Collectanea Historica: Essays in Memory of Stuart Rigold*, A Detsicas, (ed.), Maidstone, 1981, pp. 93-103.

collapsed Henry III Tower of London gatehouse of the 1240s.² Whatever their source, they start to appear from the 1250-60s and the mirrored pairs of turrets contain both clockwise and anticlockwise stairs, usually approached by ground-floor doors from within the entrance passage (e.g. Tonbridge, Caerphilly, Harlech, Beaumaris) or from the bailey (Llansteffan, figs. 45, 46.3).³ Is there any clear, logical or functional reason for such an arrangement? Was it a one-way system for rapid movement of personnel without getting tangled up when passing each other, or was it a hierarchical signal when approaching gatehouse suites that some rooms were private (i.e. on one particular side) and the other side more utilitarian? The latter question is made more difficult when noting that some large single gatehouse rooms were spread right across the building. Had the King’s masons by this time devised rules so that clockwise ascent meant one thing and anticlockwise another? Or was it just a practical or aesthetic feature that mirrored custom and practice in cathedrals as already noted?

² Goodall, 2011, p. 191.

³ See D. J. C. King, *Lanstephan Castle*, Official Handbook, HMSO, Cardiff, 1963 (1977), pp. 27-28. Whilst King suggests a 1280s date, he does not dismiss the possibility of a 1260s date. Also note John R Kenyon, 2010, pp. 82-84 (Llansteffan) who suggests it might even pre-date Caerphilly.

The Rise of the Anti-clockwise Newel Stair - The 13th century



Fig. 43. Tonbridge. c. 1250-60s. The gatehouse from the bailey, with the the half-round stair turrets at the angles. A four storey self-contained block of outstanding virtuoso quality. Tread risers are a monumental 28+cms and are probably the steepest stair treads in England. The cut-slab winders are 1.12m, similar to Caerphilly Inner W Gatehouse.

There is a similar set of questions for the Edwardian castles' sets of mural towers. A number of these castles include singleton towers with anti-clockwise spiral stairs (*Table 2*). It has been suggested that the direction or rotation was dictated by its function. Stephen Friar states that: 'In the majority of cases where heavy or awkward items (such as buckets of water) had to be carried to an upper floor, the stair would ascend in a clockwise (CW) direction, allowing the load to be carried in the right hand while climbing on the broad outer sections of the winders. It is also likely that, where possible, stairs were used in pairs, one for ascending and one for descending in order to avoid confusion and inconvenience.'¹ This is a reasonable thesis, and reinforces the generally held view stated earlier that it was easier for right-handed persons to ascend spirals in a clockwise fashion, particularly when carrying objects, and that there may well have been a one-way system that evolved for the keep-gatehouses. But it does not explain the apparently random distribution of these ACW stairs throughout the Edwardian single-placed wall towers, for example at Flint, where every corner

¹ See Stephen Friar, 2003, pp. 275-280.

tower is anticlockwise (fig. 46-4), or at Caerphilly, Caernarfon and Beaumaris.² At Caernarfon, most of the ACW stairs occur in the four-storey towers of the Lower Ward (Eagle Tower, Well Tower, Chamberlain Tower) (fig. 46.5), with all residential towers above their respective ground floors. At Conwy there is only one ACW - the Bakehouse Tower in the Inner Ward, which despite its name, above the ground floor are two levels of high-status residential accommodation, perhaps accommodating the ladies and officers of the queen. In other words, the function or name of the tower does not seem to associate itself with any particular operation that would suggest a preference for CW or ACW stairs. It may have been down to purely pragmatic architectural solutions, trying to drawing light sources from wherever available.

² For Caernarfon see Cadw Guidebook, 2004 (Arnold Taylor); for Conwy see Guidebook, 2007 (Jeremy Ashbee); for Beaumaris see Guidebook 2004; (Arnold Taylor); for Caerphilly see Guidebook 1997 (Derek Renn), and *An Inventory of the Ancient Monuments in Glamorgan III part 1b*, RCAHM (Wales), 2000, esp. pp. 51-104; for Flint with Ewloe see Guidebook 2001 (Derek Renn and Richard Avent).

The Rise of the Anti-clockwise Newel Stair - The 13th century



Fig 44. Caerphilly Castle. Inner East Gatehouse, 1268-71. The single room with the two large windows was probably the Constable's Hall. Note that, like Tonbridge, the stair turrets are not accessible from the inner ward.

13th century 'Tonbridge-style' Keep-Gatehouses* and Edwardian Castles with ACW stairs						
Castle	Dates	Clock-wise	Anti-clockwise	Gatehouse (GH)	Towers :	Vaulted or Cut-slab
Pembroke*	1250s	1	1	GH mirror x 1	South Outer Gatehouse.	V
Tonbridge*	1250s-60s	1	1	GH mirror x 1	SW turret of Gatehouse.	C
Llansteffan*	1260-65?	1	1	GH mirror x 1	NW turret of Gatehouse.	C
Leybourne*	1266	?	?	?	Gatehouse	?
Caerphilly*	1268-77	7	5	GH mirror x 2	I.East (N), I.West (N), NE, SE.	C
Goodrich*	1270-1295	1	0	GH - single tower	Single octagonal - perhaps 1300s.	C
Kidwelly	1270-80	3	1	GH (1390-1410)	SW Inner Tower.	C
Aberystwyth*	1277	2	0	GH not mirrored		?
Flint	1277-86	1 - GT	3	No	SW, NW, NE Towers	C
Caernarfon	1283-1330	5	4	No	Well, Chamberlain, Eagle, Black	C
Conwy	1283-87	6	1	No	Bakehouse Tower.	C
St. Briavels*	1292-3	1	0	GH	East turret	
Beaumaris*	1295-1306	6	4	GH mirror x 2	NE & S GHs, NW & SE towers	C
Chirk	1300-10	?	1	GH not paired	NW corner tower	C

Table 2

The Rise of the Anti-clockwise Newel Stair - The 13th century - Summary



Fig 45. Llansteffan. The 1260s gatehouse from the south, from inside the lower ward. The main entrance was blocked in the Tudor period. The present entry point via the wooden stairs may not have been the original. Unlike Tonbridge and Caerphilly the stair-turrets here are solid from the basement to the first floor.

The Gothic - 13th century period - Summary

The period sees the introduction of the cut-slab spiral stair in England and Wales, the earliest, probably at Dover c.1221-7 and certainly at York, c. 1245, (figs. 36-38, 39-41)¹, but vaulting did persist, for example at Pembroke gatehouse.² This change appears to have necessitated a reduction in the spiral-stair winder width /diameter (average width - less than 1m). They widened again later as the stair became a more status-driven architectonic feature, but not until the late-fifteenth and early-sixteenth centuries with the introduction of brick. The 'Tonbridge-style' gatehouses introduced in the 1250s-60s, and persisting into the late-fourteenth century, adopted paired CW and ACW spiral stairs probably as one-way circulation systems.

¹ There is an earlier example at Carrickfergus Castle, Ulster, (N. Ireland) c. 1180s. See Conclusion.

² The spaciousness, exquisite geometry and quality of stone steps, shafts and vaulting merging into a finely crafted sculptural entity would remain very attractive aesthetically especially in the 13th century. At Caerphilly, the hybrid stair construction is unusual if a little haphazard. The steps are laid out on cut-slabs composed of courses of closely overlapping thin flat stones sometimes resting on shoulders and corbelling springing from the casing, often giving a curious 'birds nest' network effect to the spiral. See fig. 47.3.

This move was driven technically by the constraints of narrower widths and greater tread heights of one-piece cut-slab winders, leading to stairs becoming more precipitous, claustrophobic and uninviting. Winder heights tend to be similar to the ashlar blocks used in the containing wall, facilitating ease and speed of construction (average riser height between 19-28 cms). CSG members may recall seeing a fine example of a unique form of ashlar 'vaulting' or, more precisely, interlocking sculpted winders, at Clonshire Hall-house, Limerick, dating to the early sixteenth century where the undersides of the winders are smoothed off seamlessly and embedded into the enclosing cylinder at a tilted angle.³ This elegant but rather rare feature is also seen at Maxstoke (fig. 64) and Tattershall (fig. 74).

³ CSG *Journal*, 23, p. 58. The finish is so good it appears to be emulating the celebrated Vis de Saint Giles, Arles, Provence, (1142), a staircase that takes geometry and the flowing line to new heights of beauty and accomplishment. This still attracts masons who make the pilgrimage to Saint Giles du Gard. The bell tower north of the Abbey is now a ruin, but 50 vaulted steps are still intact. There are a number of west of Ireland tower houses with similar stairs to Clonshire: Aughnanure, Cahererillan, Drumharsna, Derrymacluaghna, Fiddaun, and Lydacan, all Co. Galway. Rockstown and Fantstown, both Co. Limerick. I am grateful to Dr Gillian Eadie for providing this data.

The Rise of the Anti-clockwise Newel Stair - The 13th century

Examples of 13th century ACW cut-slab spiral stairs.



Fig. 46.1: St Thomas's Tower - 1260s, Tower of London. 2: Llansteffan - NW stair-turret 1260s. 3: Tonbridge Castle, 1250s-60s ACW stair - risers 28 cms in height. 4: Flint - NW Tower 1270s. 5: Caernarfon - 1280s.

The Rise of the Anti-clockwise Newel Stair - The 13th century



Fig. 47. Caerphilly Castle. 1. Inner East Gate house. The north ACW stair turret - ground floor (with renewed newels). Width 1.48m. 2. Inner East Gatehouse, north ACW stair turret (with renewed newels) first floor. Winder width 1.48m. 3. Inner East Gatehouse - north ACW stair turret (with renewed newels) first floor, highlighting the original winders embedded into the turret casing (2 overlaid cut-slabs per winder). 4. Remains of the destroyed NE Tower of the Inner Ward with its ACW stair.

The five ACW stairs at Caerphilly are: Inner East Gatehouse (N), NE Tower, Inner West Gatehouse (N), Apartments west of the Great Hall (but not around a newel; SE Tower).

The Rise of the Anti-clockwise Newel Stair - The 13th century



Fig. 48. Goodrich Castle. Rear of the gatehouse with the octagonal stair turret (right), c. 1310-20 (Stair width 1.25m; tread/ riser height 18.4 cms). Figs. 49, 50. Below. The octagonal stair turret with CW cut-slab winders c. 1300-10.



The Rise of the Anti-clockwise Newel Stair - The 14th century



Fig. 51. Dunstanburgh. Gatehouse c. 1314-20 from the south, with mirrored CW (east, right) and ACW spiral stairs (west, left) within the wall thickness.

The 14th century, Edward II, III, Thomas of Lancaster, and Kenilworth.

The initial period of the fourteenth century continues to see the development of large set-piece residential D-shaped towered gatehouses, town gates in Kent and Sussex and the introduction of polygonal towers. The period also sees the development of quadrangular courtyard plans with the accent on display and a unified symmetry. Those continuing the fashion for the 'Tonbridge-style' gatehouse configuration include Gilbert de Clare's Llangibby (1307-14), (fig. 52), hexagonal-turreted Boarstall Tower, 1312 (figs. 58-9), Lancaster's Dunstanburgh 1314-20, (fig. 51), to a lesser degree Rye Town Gate (Landgate), and Canterbury West Gate, 1380s. Llangibby and Dunstanburgh continue the established paired-mirror ACW/CW spiral stair convention, presumably as a one-way circulation system, but not, in the case of Dunstanburgh, the angled 'ear' corner turrets. Within the bailey and along the curtain walls the emphasis is on polygonal forms, particularly octagonal or semi-octagonal towers and residential blocks, as noted at Kenilworth, possibly c. 1310-14 with the earl of

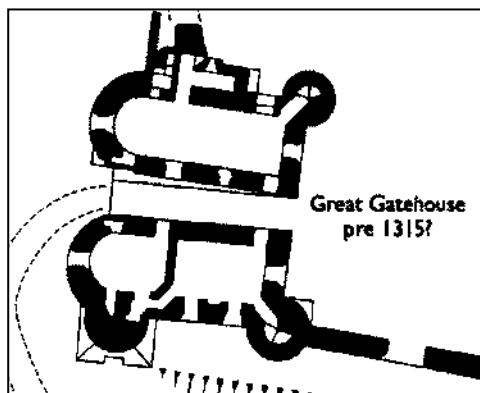

Fig. 52. Llangibby. The SW Great Gatehouse with paired staircase turrets: CW (north) and ACW (south). Note latrine tower bulge in S. After Salter.

14th century English & Welsh Castles & Town Gates /Towers with Anticlockwise Spiral Stairs

Kenilworth (4)	(2) 1310-14, (2) 1370s
Dudley (<i>Donjon</i>) *(1)	1265-80
Newark (Notts) (1)	1300-10 west wing.
Middleham (2) NW, S.	1300-1320?
Newport, Wales (1)	1300s +1390s. N. Tr
Dunstanburgh (1)	1314-20 GH mirror
Llangibby (1) (SE)	1315-20 GH mirror
Dalton Tower (1)	1320s
Chester Water Tower (1)	1322-25
Carisbrooke (1)	1335. GH, south turret
Maxstoke (1)	1340s GH mirror
Stafford (2)	1348 Entrance mirror
Compton Castle (1) Hall	1350s
Bronllys (upper level) (1)	1350s
Dacre Castle (2)	1350s
Warkworth (2)	1370-1400
Canterbury West Gate (1)	1380
Bolton (5)*	1380-90s
Cartington (1)	1380s
Rye - Landgate (1)	1380s GH
Wingfield, Suffolk (1)	1385 GH Mirror
Bodiam (1) GH range	1385-90
Donnington (2)	1386 GH mirror +1
Saltwood (1)	1386 GH mirror
Old Wardour (1)	1395
Cow Tower, Norwich (1)	1398-9

* Dudley - basement to hall only.

* Bolton - see text

(38)Table 3

The Rise of the Anti-clockwise Newel Stair - The 14th century



Fig. 53. Newark on Trent Castle. West curtain c. 1300-1310. Anticlockwise ascending stairs adjacent to the Middle Tower, rising from a window recess in the Great Hall. It can be readily observed that the steps (winders and newels) are one solid cut-slab piece and that the winder ends dovetail quite deeply into the face of the cylinder shaft or turret

The Rise of the Anti-clockwise Newel Stair - The 14th century

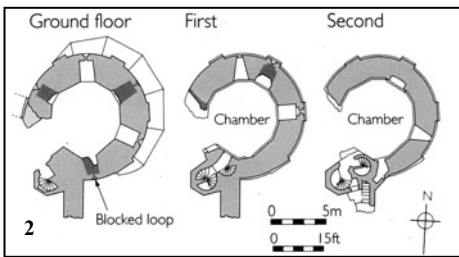

Fig. 54. 1: Kenilworth, Lunn's Tower (1210-15) from the west. 2: Lunn's Tower floor plans, © & courtesy English Heritage (EH Guidebook p. 31). 3: The added c. 1310-14? ACW cut-slab staircase in the semi-octagonal stair-turret seen above in (1) and (4). Winder width 0.82m, height 23cms). 4: View of the Lunn's Tower staircase turret from the SW, located outside the perimeter curve of the tower, enabling the tower chambers to be used as private accommodation.

The Rise of the Anti-clockwise Staircase - The 14th century

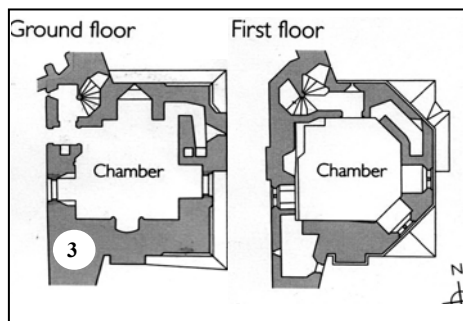

Fig. 55. 1: Kenilworth, the Water Tower, south of and abutting the later stable block. Probably built in the early 14th century, by Thomas of Lancaster, the tower provided additional well-equipped lodgings for Thomas's leading retainers. 2: The cut-slab ACW stair in the NW corner of the ground-floor chamber. Winder width 1.20m, height 18.5cms. The staircase broaches into a mini-octagonal turret beyond the first floor (cf. Newark). It appears to be contemporary with the Lunn's Tower staircase. 3: Floor plans of the ground floor and first floor Water Tower chambers, © & courtesy English Heritage (EH Guidebook p. 31).

The Rise of the Anti-clockwise Staircase - The 14th century



Fig 56. Kenilworth Castle - The Strong Tower. Narrow ACW stairs (0.83m) linking the room to two strong-rooms



Fig 57. Kenilworth Castle - Saintlowe Tower. Narrow and steep ACW (0.83m, riser height 24 cms) stairs.

Lancaster (1278-1322) and in the 1370s under John of Gaunt (1340-92). Thomas, earl of Lancaster's works probably include the Water Tower (figs. 55.1-3) and other additions to the outer bailey wall, including a new stair turret to one side of, but integrated with Lunn's Tower, c. 1310 (figs. 54.1-4).¹ This new turret sits outside the line of the tower wall, thus allowing access to the wall-walk without entering into and through the tower, making the tower chambers more private.² In both instances the anticlockwise stair turrets are probably the work of one hand (compare figs. 54-3 and 55-2). Other individual thirteenth-century towers with anticlockwise stairs include the Chester Water Tower (1322-25) by Edward II's

¹ Lunn's Tower was constructed at the end of the first decade of the 13th century by King John in the late-Norman Romanesque style complete with its distinctively long fish-tail arrow loops, exterior pilasters and splayed base. It appears to the writer that the semi-octagonal stair-turret described above with the pointed-arch entrance is a *later* extension to the tower, added by Thomas of Lancaster. The stonework looks similar and the tower appears to be integrated seamlessly but it was probably added at the same time the Water Tower was constructed about 100 years later.

² A two-storey timber building was once connected to the tower. It was probably the house built by the Constable, John Ashford, which, in 1400 was confirmed in the possession of his wife, together with the 'tower adjoining'. See EH Guidebook, 2006, p. 31.

master-mason in the north-west of England, John de Helpston, a tower circular to the exterior but octagonal to the interior, the West Postern Gate at Warkworth, and the NW gate-tower at Donnington, Berkshire.

Kenilworth also saw significant redevelopment under John of Gaunt, who rebuilt the Great Hall (1373-80) at first-floor level. At either end of the hall there are two similar symmetrical looking residential/service towers, the Strong Tower at the east service end, and the Saintlowe Tower at the high end; both towers included small twin octagonal turrets to the exterior perimeter of the Inner Court.³ In the Strong Tower the ACW spiral stair in the SW corner (fig. 56) leads up to the rooftop, with the best panoramic view of the whole castle, and down to the strong-room(s).⁴ The Saintlowe Tower is also ACW (fig. 57), and gave access to the wine cellar below and chamberlain's lodgings.

³ Octagonal or semi-octagonal stair turrets became fashionable in the late-13th century. In addition to those mentioned above at Kenilworth, there are fine examples at: Burnell's Hall, Wells Bishop's Palace, c. 1275-92; Goodrich Castle, rear of the gatehouse, probably early 1300s; Markenfield Hall, 1309-12; Clevedon Court 1320s; Penshurst Place, 1338-40; Stafford Castle, 1348, and Sudeley, 1450s.

⁴ The Strong Tower stair dimensions are: winder width 0.83m, riser height: 23cms. The Saintlowe Tower: winder width: 0.83m, riser height 22 cms.

The Rise of the Anti-clockwise Staircase - The 14th century



Fig. 58. Above: Boarstall Tower gatehouse, c. 1312-14. Central bay over entrance, balusters, chimney stacks, later. The original gatehouse to a country seat, now lost. Fig 59. Below: Boarstall Tower. Rear (south) view. $\frac{3}{4}$ round hexagonal stair turrets with independent ground-floor doors in the courtyard. These rear doors to the turrets were originally the only access to the upper floor(s). The pattern of fenestration (though not the present style - they are early C17) is similar to Caerphilly and Tonbridge. The interior of the turrets are cylindrical. The east turret (right) is larger than the west; tread width 0.92m. Arrow loops are similar to the Kenilworth Water Tower.



The Rise of the Anti-clockwise Staircase - The 14th century



Fig. 60. Maxstoke Castle. The gatehouse from the east.

The middle of the fourteenth century witnessed a greater emphasis placed on status, privacy, and domestic comfort. The exterior of the castle was increasingly developed to make an impact statement about the status of the owner, and the gatehouse block came to be the most prominent feature of the frontage - especially by heightening, embellishing and fitting out as high-status accommodation. The martial air is maintained, but the trappings of fortification become more of a noble architectural style, although many features still remained functionally defensive.

Maxstoke - a paradigm

Maxstoke Castle, Warwickshire, visited by the CSG in April 2003, is a product of the Edward III (1312-77) period, when William de Clinton (d. 1354) received his 'licence to crenellate' in 1345, though the castle was probably building prior to this. It is laid out to the then fashionable quadrangular courtyard plan with octagonal corner towers (fig. 61). In the middle of the east curtain is a boldly projecting three-storey gatehouse with semi-octagonal turrets standing proudly forward of the curtain wall (fig 60). Whilst the imposing gatehouse towers suggest that they might be strong defensive platforms, the front turrets actually only contain one clockwise spiral stair in the SE turret, ascending from ground floor to roof level and subsidiary service rooms with latrines in

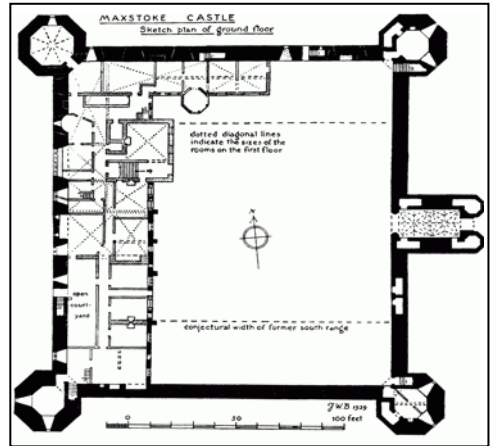

Fig. 61. Maxstoke Castle, plan.

the NE turret (figs. 62-64). The beautifully tooled clockwise cut-slab stair is 1.07m in width with a surprisingly high 25 cms riser.¹ The octagonal turrets contain no arrow loops, and the gatehouse contains a suite of two lodgings - residential accommodation on two floors, each with one large open room with fireplaces.² Maxstoke represents a period when the full military or castellated appearance of a castle becomes partly pseudo in its military efficacy. That is not to say that the trappings of fortification at Maxstoke are purely symbolic or token, but the building is best described as a castle the takes the form of a 'fortified house'. However it does have some substantive defensive features. The roof-top battlements, the drawbridge (now lost), the moat - up to 12ft deep, the portcullis, murder holes and outer and inner gates were all workable enough. The embattled parapets still have the evidence of the sockets in the side of the merlons for wooden shutters to close the crenels in case of attack.

¹ The elegant undersides of the interlocking sculpted cut-slab winders are smoothed off seamlessly and embedded into the enclosing cylinder wall at a tilted angle.

² In this respect the Maxstoke gatehouse is similar to Donnington (1386) and Saltwood (1380), where they have frontal stair turret(s) only. Wingfield Castle 1385, (Suffolk) and Boarstall Tower both have rear and frontal turrets, but in the case of Boarstall (1312-14) there are paired hexagonal staircase turrets to the rear, in a continuation of the 'Tonbridge-style' gatehouse tradition, with moat, drawbridge and portcullis. (John de Haudlo was custodian at Tonbridge Castle); the paired rear spiral stairs are both CW. Hexagonal towers are rare but not unknown at this time (e.g. Newark, North Tower). Wingfield has semi-octagonal frontal turrets and polygonal ¼ round 'ear' staircase turrets to the rear.

The Rise of the Anti-clockwise Staircase - The 14th century



Fig 62. Above. Maxstoke Castle. First floor 'Constable's Chamber' over the gatehouse passage, looking towards the west window (right) and south window (left), and door to the wall-walk. Fig. 63. Below left. The SE stair turret looking down from the first floor. Fig 64. Below right. The smoothed sculptural undersides of the cut-slabs producing a seamless curvaceous helix.

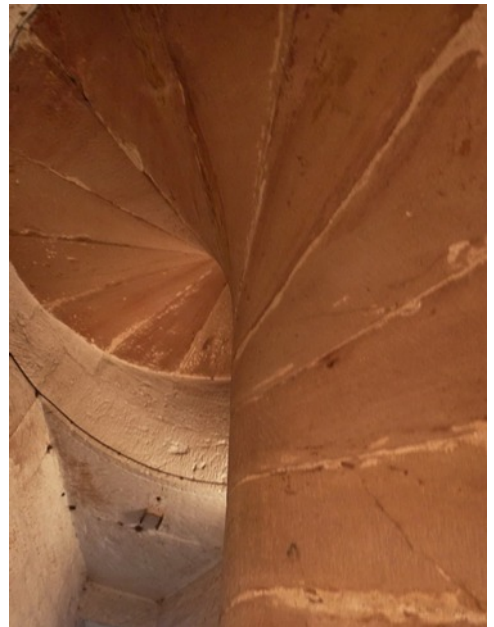

The Rise of the Anti-clockwise Staircase - The 14th century



Fig 65. Bolton in Wensleydale Castle, Yorkshire, c. 1378-96, from the west. A licence to crenellate was issued in 1378.

Bolton Castle

Bolton castle stands today as one of the most complete and best-preserved palace-fortresses of late-medieval England (figs. 65, 66.1-4). Richard le Scrope (1327-1403), Lord Chancellor between 1378-82, built quadrangular-style Bolton between 1378 and 1396, an 18 year building project. The moatless, austere exterior conceals a skillfully interlocking sequence of halls and chambers, ensuring privacy, hierarchical status and isolating security - services and guards on the ground floor followed by a level for the Lower Hall and suites, Upper Hall and suites, and finally the Great Hall with suites. It is an outstanding example of the permanent accommodation needed within a single building by a leading magnate and his family - the building could have housed upwards of 200 persons.

Thus, like Goodrich in its final configuration, and Bodiam (1385-90) the castle becomes one integrated architectural form, uniting residential, domestic and defence functions in a cleverly devised graded hierarchical plan. Bolton contains eight distinct suites of accommodation for individual households, together with 12 single-chamber apartments for household officials and

others.¹ A rare original contract still exists for the construction of the first phase of the castle in 1378. This was undertaken by master-mason John Lewyn² of Durham and covers, for example, the rates of payment and workload obligations on Lewyn and Scrope.

The floor plans indicate that there were five anticlockwise stairs and possibly four clockwise.³ There does not appear to be any obvious reasons for the choice of either in each range, but the spiral winders do scale up in width according to the status of the type of room use; services; lodgings and Great Hall, lordly apartments, with the largest on the partly destroyed north range.

¹ See Faulkner, P. A., 1964, 'Castle Planning in the 14th Century', in *The Archaeological Journal* Vol. 120 pp. 225-30, 234; M. J. Hislop: 'Bolton Castle and the Practice of Architecture in the Middle Ages', in the *Journal of the British Archaeological Association*, Vol. 149, 1996, pp. 10-22; also M. J. Hislop: *John Lewyn of Durham: a medieval mason in practice*, Oxford: John and Erica Hedges, 2007, (BAR British series; 438).

² Also probably responsible for Raby, Wressle, Sheriff Hutton, and Warkworth castles.

³ For floor plans see Emery, Vol I, 1996, pp. 306-7. See also *Bolton Castle Visitor's Guidebook*, c. 2000.

The Rise of the Anti-clockwise Newel Stair - The 14th century



Fig. 66. Bolton Castle ACW stairs. 1. SW stairs, entry up to chapel and lodgings. 2. SW stairs looking down from the first floor. 3. SW Stairs from the ground floor. 4. East (Gateway entrance) range, remains of spacious centrally-placed stair up to lodgings at either side.

The five newel ACW stairs at Bolton are: 1) North Hall and Kitchen range (2 stairs) - NW lodging tower and Grand stair up to the Great Hall. 2) - East Range (1 stair) - Ground-floor to lodgings; 3) South Range (2) - SW Corner Tower, SE Corner Tower.

The Rise of the Anti-clockwise Newel Stair - The 14th century

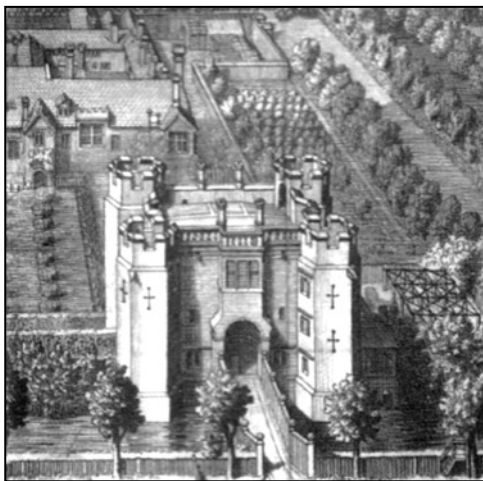

Fig. 67. Boarstall Tower. Gatehouse from the north highlighting the four hexagonal towers and the 1614 Jacobean modifications (e.g. chimney stacks, balusters, and bay window with supporting arch over the entrance. Engraving by Michael Burghers, 1691. The house was demolished in 1778.

The 14th century - Summary

The early part of the century saw a continuation of the twin-towered gatehouse format with mirrored and usually paired CW and ACW stair turrets to the rear, for example at Llangibby. Boarstall Tower (figs. 58-59, 67) is unusual as it contains CW stairs in both rear hexagonal turrets.¹ Gatehouse stair turrets were usually $\frac{3}{4}$ round, of the angled 'ear' type, admitting more light than a half-turn turret. By the 1350s gatehouses had become more of an aristocratic showpiece used for guest or household lodging and the stair turrets occasionally moved to the front 'D' of the towers, as with Maxstoke, and Donnington. The enduring legacy of the 'Tonbridge style' gatehouses continued into the Tudor period (Lullingstone, 1497-1510, brick construction) in their general form with their attenuated octagonal or semi-octagonal turrets. Whilst the courtyard castle was the norm, the forms of newly-built castles became more diverse and pluralist with the emphasis on prestige,

¹ John de Haudlo received a licence to crenellate Boarstall in 1312, and the gatehouse is purported to be copied from Caernarfon in general form: stone banding etc. All four towers are hexagonal. The only original entrances to the staircase turrets were from the south, garden side. The principal east turret is slightly larger than the west, and the tread risers at 18.5cms are lower than the west turret (at 21cms). Both staircases wind clockwise.



Fig. 68. Belsay Castle, Northumberland. Umbrella vault that caps the cut-slab spiral stair, c. 1370.

planning, comfort, a multiplication of lodgings and a socially defined hierarchy.² In many castles both clockwise and anticlockwise single staircases were used equally and seemingly indiscriminately, but all were built using the one-piece cut-slab winder method of construction. The winder widths / tread heights appeared to be the sole mark of status, but other than that there was no additional architectural embellishment that made the staircase a distinctive feature, with the exception of the umbrella vault at the summit of the turret. It remained purely functional. Lights remained small, but gradually increased in size, and the loops developed an external regularity (fig. 66.4). Single semi-octagonal stair turrets centered mid-range in a courtyard plan became popular, often linking separate adjacent rooms or lodgings at upper levels, e.g. Newark, Bolton. Other singletons are often placed in the re-entrant angle between adjoining blocks or between porch and service areas off the Great Halls, e.g. Compton Castle. In some northern examples, the top of the staircase turret is finished with an elegant umbrella vault - the ribs radiating out from the top of the newel. 14th century examples include Belsay (1370, fig. 68), Alnwick and Warkworth (1370-1400). Warkworth includes a number of ACW newel stairs, including the West Postern Gate in the Inner Ward that rises to a portcullis chamber, and a staircase that rises from chapel in the tower to the oriel. At the end of the period, elegant corbelled out brackets to cradle the winders are seen at some of the more high-status stairs at Old Wardour (c.1392) (fig. 69).

² See Thompson 1991, p. 164 for a complete list of all new and major construction work on English castles in the 14th century.

The Rise of the Anti-clockwise Newel Stair - The 14th century



Fig. 69. Old Wardour Castle. The CW spiral stairs from the Great Hall to lodgings on the second and third floors., highlighting the quality of the stonework, the chamfered undersides of the winders and chamfered corbels inserted into the containing wall for the cut-slabs to rest on. An unusual feature in English castles.

The Rise of the Anti-clockwise Newel Stair - The 15th century



Fig. 70. Nether Hall (or Netherhall), Roydon Essex, c. 1460s. Remains of the gatehouse. An early example of a prestigious brick-built gatehouse tower. The remaining standing building is built of brick with blue brick diaper (an all-over surface decoration of a small repeated pattern) work and decorated with trefoiled corbel friezes. The single ACW staircase turret is to the right, with the decorative corbelling. Built by Thomas Colte, the richest commoner of Edward V's regime, it is one of the most accomplished fifteenth century works of brick architecture anywhere in England.

The Rise of the Anti-clockwise Newel Stair - The 15th century



Fig. 71. Oxburgh Hall. c. 1480s. West gatehouse turret. ACW stairs, not matched or mirrored in the east turret. Brick newels, winders, countersunk handrail and vaulting.

The 15th century, Ostentation, and Bricks.

Although clockwise newels continue to predominate in the 15th century, as they had in the 14th, the ratio had changed from 20:1 in the Norman period to approximately 2:1 by 1500. By the early 16th century, straight and open newel anticlockwise staircases begin to predominate. In addition to those castles or castellated house examples highlighted in Table 4, domestic examples include Cothay (1480s), Gotherney Manor, Somerset, and Mells. The octagonal plan becomes general, and by the middle of the century the brick staircase is becoming a significant architectonic feature to be displayed.

Constructionally, brick steps necessitated the return of vaults to support the rows of bricks used for the treads (figs. 71, 80-81). Newels were built up of curving moulded bricks, and the containing shafts often contained bricks laid more frequently as headers to cope with the wall curvature without using moulded brick. This allowed for wider winders and a more elegant treatment of the vaulting. But in the first half of the fifteenth century Ralph, Lord Cromwell's (1394-1456) magnificent Great Tower (1432-48) at Tattershall set the pace

15th century English & Welsh Castles with Anticlockwise (ACW) Spiral Stairs .

Kidwelly (1)	1408 GH (addition)
Wells, Bishop's Palace (1)	1450s
South Wingfield (1)	1440-59.
Ludlow (1)	1450s?
Nether Hall (1)	1460s-70s GH, Brick
Kirby Muxloe (2)	1480s GH mirror. +1
Oxburgh Hall (1)	1480s GH Brick
Faulkbourne Hall (1)	1490s Brick

(9) Table 4

15th century English Castles with clockwise (CW) Spiral Stairs - in brick .

Tattershall Castle - Tower	1430-40s
Herstmonceux Castle	1446
Caister Castle	1459
Hunsdon	1450s
Farnham	1470-77
Bishop's Palace, Hatfield	1480s
Rye House - Gatehouse	1490s
Hadleigh Deanery Tower	1490s

Table 5

The Rise of the Anti-clockwise Newel Stair - The 15th century



Fig. 72. Tattershall Castle. c. 1440s. CW stairs, with stone cut-slabs and ashlar hand-rail.

with brick, although, in this particular instance, the stair turret, whilst the wall is of decorative brick, maintains stone cut-slab winders of generous proportions with their integral newels. What is particularly innovative is the beautifully crafted continuous ashlar inset or countersunk handrail meticulously set into the brick retaining shaft, and the carefully precision-placed ashlar slab winder steps with rear / underside chamfers giving a more sculptural look. (figs. 72-74, cf. Maxstoke, fig. 64). Each winder - width: 1.32m - is the height of three courses of bricks; tread height 18cms. The clockwise spiral stair is located within the octagonal SE corner turret of the tower, rising through each of the four storeys to roof level. It is the only stair in the tower. The large cinquefoil traceried headed windows giving ample light to the turret.¹

Whilst great towers had been out of fashion in England since the thirteenth century, tall residential towers returned in the fifteenth century as seigneurial expressions of wealth and power. A crop of tall free-standing towers or residential gate-

¹ For brick spiral stairs See also T. P. Smith, 'Rye House, Hertfordshire and Aspects of Early Brickwork in England' in the *Archaeological Journal*, 132 (1976), pp. 111-150, esp. pp. 137-8, 141.



Fig. 73. Tattershall Castle. c. 1440s. CW stairs, with stone cut-slabs and ashlar hand-rail. Detail of the hand-rail.



Fig. 74. Tattershall Castle. c. 1440s. CW stairs, with stone cut-slab winders and ashlar hand-rail.

houses sprang up in this period including Hunsdon, (brick and stone, 1450s), Farnham (brick, 1470s), the Hastings tower at Ashby de la Zouche (stone - 1470s), Hertford Gatehouse, (brick, 1460s). The possibilities of using brick for deliberate display had only been grasped in the last decades of the 14th century (Thornton Abbey Gatehouse, 1360-70s), and now came into full bloom in the second quarter of the fifteenth century when major buildings of brick were erected in several parts of the country.

The Rise of the Anti-clockwise Newel Stair - The 15th century



Fig. 75. Kirby Muxloe Castle, c. 1480-83. The entrance façade from the north-west. The Licence to Crenellate was issued in 1474. The gatehouse is extensively decorated with diaper work under the direction of John Cowper, master-mason. Fig. 76. Below: The south-west-facing courtyard façade of the gatehouse. Symmetry is evident with mirrored pairs of staircase turrets accessed from the stone-surround doors in each turret. The ACW stair is in the right (NE) turret.



The Rise of the Anti-clockwise Newel Stair - The 15th century



Fig. 77. Kirby Muxloe Castle, c. 1480-83. ACW stair in the gatehouse. Note: No brick moulded handrail. Stair/tread width 1.18m, Riser height 21 cms.



Fig. 78. Kirby Muxloe Castle, c. 1480-83. West Tower. ACW room stairs rising to the latrines at each floor level. Tread widths: 1.08m. Riser height: 21 cms.

Kirby Muxloe 1480-83

Kirby Muxloe is a domestic building of moderate defensive capability - a fortified house, rebuilt by William, Lord Hastings, shortly before his death in 1483 (Figs. 75-78). The unfinished castle would have consisted of a large quadrangular building enclosing a courtyard surrounded by a moat. At all four corners were lofty square towers. Of these, the residential West Tower remains to its full three-storey height. The gatehouse, in the centre of the west side, was originally of three storeys - now two. It consists of thin red bricks with bold diaper patterns. The plan is a rectangle with octagonal turrets in the four corners with those toward the courtyard containing the newel stairs. The forward turrets are residential service rooms.¹ The spacious newel staircase turrets are entered from the courtyard, not from within the gatehouse passage. The form of the gatehouse follows the Edwardian pattern, the stairs are mirrored pairs, CW/ACW with the ACW stair in the SE corner. The first floor now has one large room with a fireplace at either end, indicating perhaps that the room was divided into two by a wooden partition, although the symmetrical window placements did not allow an equal division. Both stairs are brick vaulted and generous, and would probably have been used independently of each other - their spaciousness militated against the need for a one way traffic flow system.

¹ See the old EH *Kirby Muxloe Castle* guidebook by Sir Charles Peers, HMSO, 1975 edition.

The Rise of the Anti-clockwise Newel Stair - The 15th century

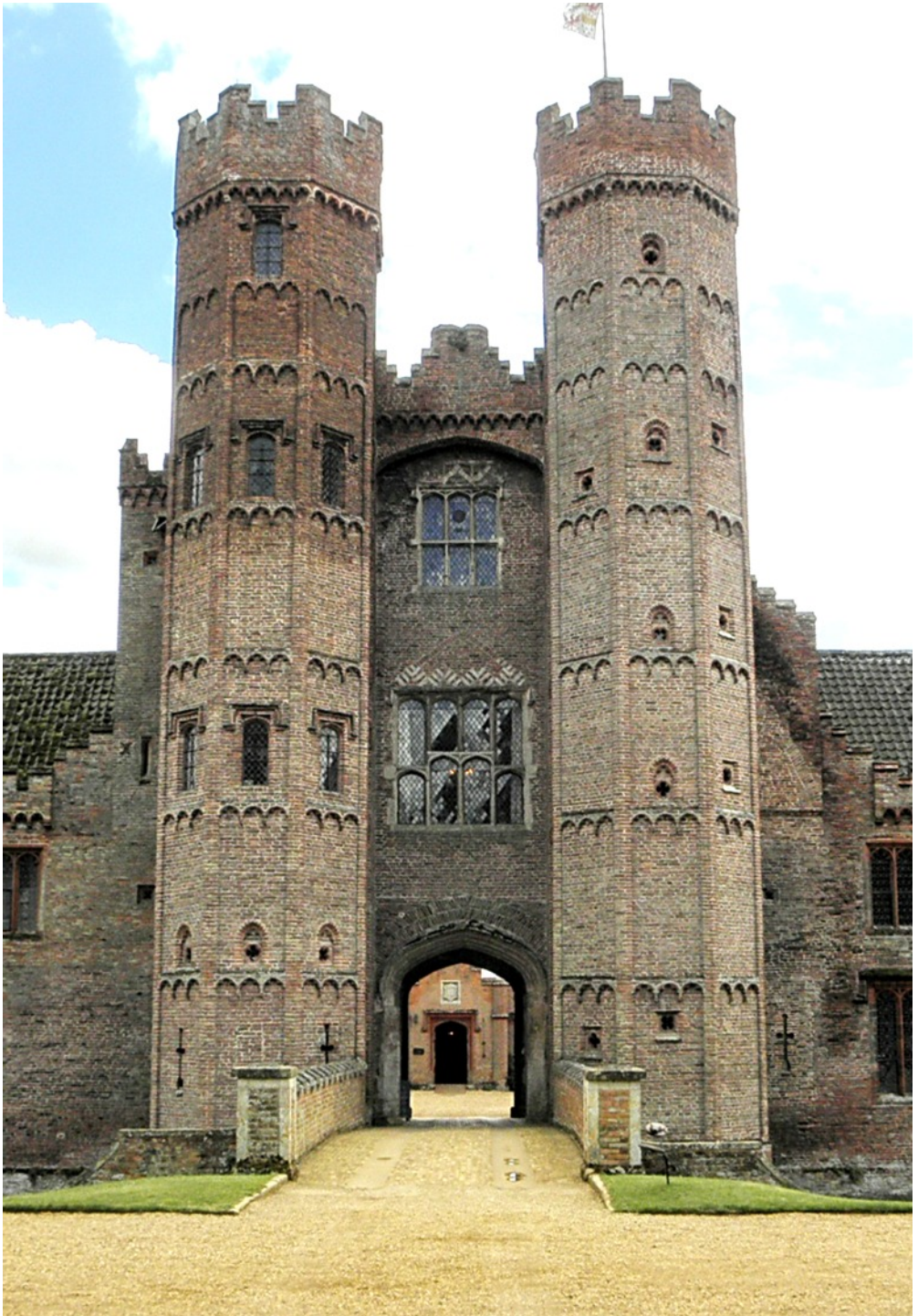

Fig. 79. Oxburgh Hall. The gatehouse, c. 1480. The front stair turret on the right (circular internally).

The Rise of the Anti-clockwise Newel Stair - The 15th century



Fig. 80. Oxburgh Hall c. 1482. Decorative arrow loops in the east gatehouse turret.



Fig. 81. Oxburgh Hall, c. 1482. The ACW newel stair in the west gatehouse turret.

Oxburgh Hall - 1482.

Oxburgh received a licence to crenellate in 1482 from Edward IV. Despite its moat and battlements it is a building meant to impress rather than to exclude. (Figs. 79-81). Constructed by Sir Edmund Bedingfield, the magnificent gatehouse at Oxburgh is the best preserved part of the original building and is a masterpiece of late-medieval brickwork. The two sets of large central windows above the entrance are the principal high-status residential chambers - known as the King's and Queen's rooms. The ACW stair turret is one of Oxburgh's most interesting architectural features. Filling the front NW octagonal tower of the gatehouse, it connects the porter's lodge on the ground floor to the roof. The brick-vaulted stair ascends anticlockwise with access to each floor; stair width 1.14m, riser 20 cms. It is a virtuoso display of the medieval brick-maker's craft, using bricks that were made on site. Although the vault is constructed from cut and rubbed brick in a complex spiral pattern, the vault surface is actually painted to simulate brickwork. The handrail, partly countersunk into the outer containing wall, is made from individually moulded bricks, unlike Tattershall. (Fig. 71 cf. Fig. 73). Oxburgh may be termed a 'lightly fortified manor house' and the gatehouse includes decorative but workable arrow/gun loops at its base in the east turret (Fig. 80).



Fig. 82. Faulkbourne Hall. c. 1480-90s. 3/4-octagonal ACW stair turret with brick vaulting, on the corner of the lodging tower, and entered from within the tower. Image from Nathaniel Lloyd's 'A History of English Brickwork' 1925, p. 371. Probably contemporary with Oxburgh, and constructed by the same workmen. See also Gomme and Maguire, 2008, p. 99, who considered that the tower was a late design change in the course of construction.

The Rise of the Anti-clockwise Newel Stair - Conclusions



Fig. 80. Dover Castle. Great Tower NE stair turret. A view of the clockwise newel rising from the basement.

Conclusions

The newel, vice stair, or *l'escalier en vis* built within its own cylindrical containing wall has been constructed in England since the tenth century. The Normans were the first to introduce it internally into a secular environment in their great *donjons* of the late-eleventh century, from the time of the White Tower in the 1070s. In these early royal buildings the width of the stair, the height of the vault and their overall spaciousness marked them out as having special elite status. The generous proportions to the approaches and ascent, especially at the White Tower, Colchester, Rochester, Hedingham, Orford, Middleham and Dover were dignified and aristocratic (Fig. 86). Arguably, such examples of the 'grand stair' emphasise the ceremonial functions of a great tower and the theatre and courtly choreography of seigniorial arrival and access.¹ Whilst slightly lower

¹ See Marshall, 2002, who suggests that some of these examples should be classified as 'Palace' or 'Ceremonial' *donjons* not necessarily designed even for short-term residential use.

tread risers are evident at Orford and Castle Rising, there was absolutely nothing dignified about climbing the spiral stair at Goodrich, indicating that great towers supported multiple functions, changing over time and place. Whilst clockwise stairs predominate in the eleventh and twelfth centuries, there are sufficient examples of anti-clockwise stairs in Britain and France in this period to indicate that the choice must have depended both on physical convenience and architectural practicalities,² and there was no military ideology that demanded clockwise staircases in the cause of fighting efficiency or advantage. Two of England's earliest and largest towers - White and Norwich - both contained anticlockwise stairs. At Norwich ACW stairs became the only choice after the NW stair was blocked up (Fig. 9).

It was noted that in the first half of the thirteenth century the vaulted staircase of the Norman and Angevin period was displaced by the one-piece cut-slab winder. Its earliest appearance in

² And possibly the left or right 'handedness' of the builder or patron.

The Rise of the Anti-clockwise Newel Stair - Conclusions



Fig. 81. Carrickfergus Castle, Ulster, c. 1180s. The great tower from the south.

England seems to be about 1220-45 amongst the King's works, including the north tower of the Constable's Gate complex - Dover (Figs. 36-37, 38.1-4).¹ This contains an anticlockwise stair that may have been conceived as early as the 1220s and added by Hubert de Burgh following his heroic defence of Dover in 1216-17. Others include Clifford's Tower, York and the Tower of London's mural towers of the Henry III era. There is, however one remarkable example that dates from the end of the twelfth century at Carrickfergus, Ulster. The great tower was built by John de Courcy (1160-1219) in the 1180s, a man no friend of King John and not within his circle. (Fig. 81). The tooling and implementation of the stairs in the SE corner is crude but it predates anything seen by the King's works by 20 to 30 years (Fig. 82).

From where or with whom did this type of stair originate? It seems likely to have been developed in late twelfth-century France. One example is the rectangular *donjon* at Grand-Pressigny, Indre-et-Loire c. 1180s containing an ACW cut-slab stair in its bulging SE corner buttress (Fig. 83).² It is also evident in the towers of Philip Augustus,³

¹ Lower guardroom, North Tower, according to the Toy, 1953, plan, p. 148. Precise date uncertain.

² The tower is designated by Mesqui into the category of a "*tours beffroi*", built to affirm ostentatious seigneurial power. (Mesqui, 1991, pp. 96-105, 112). According to Mesqui these are non-residential towers.



Fig. 82. Carrickfergus Castle, Ulster, c. 1180-90s. The rough underside of the earliest known one-piece cut-slab spiral stair in the British Isles.

and his ally Enguerrand III, the builder of Coucy, about 40 miles north-west of Reims, c. 1220-32 (Figs. 84-85). In addition to having five anti-clockwise newel stairs built into the wall thickness of the mural towers and only one clockwise stair,⁴ the remaining evidence indicates that the stair treads at Coucy were single-piece cut-slab winders. A slight difference from the English examples are that the winders rest on corbels fixed into the cylinder rather than being embedded themselves. Everything about Coucy is unusual. Viollet-le-Duc records that: 'It would seem as if this keep was built for a race of giants, and the appearance of the structure is in harmony with the power displayed in its execution every-

³ The towers became known as *Tours Philippiennes*, and include towers in the following non-exhaustive list: Châteaudun; Chinon; Falaise; Gisors; Loches; Louvre; other castles of interest in this period are: Issoudun, Lillebonne, Najac; Fère-en-Tardenois (Aisne, 1206); Dourdan (1220); Coucy le Château (Aisne, 1220s); Carcassonne (1225); See also Mesqui, 1991, Vol I, pp. 41-44 and Thompson, A. H., 1912, pp. 160-187.

⁴ Coucy Castle: The Great Tower, B, Wall towers D, C, S, and T as shown on Fig. 84.

The Rise of the Anti-clockwise Newel Stair - Conclusions

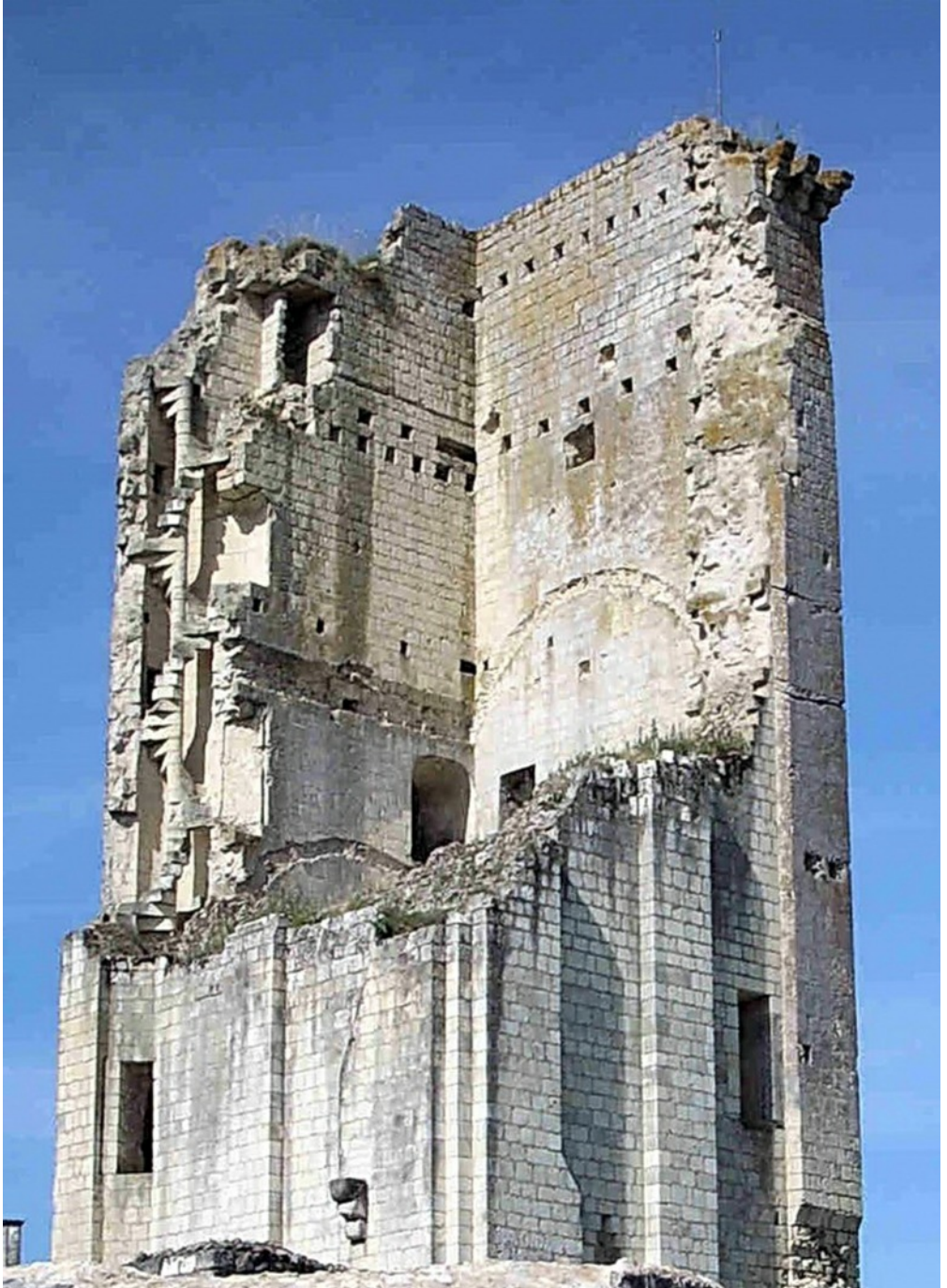

Fig. 83. Donjon du Grand-Pressigny. The date of the donjon is not settled but it appears to be late 12th century, perhaps 1180s. The spiral staircase, in the SE corner buttress is accentuated by the outward curve of the façade on both angles. The winders are very narrow cut-slabs.

The Rise of the Anti-clockwise Newel Stair - Conclusions

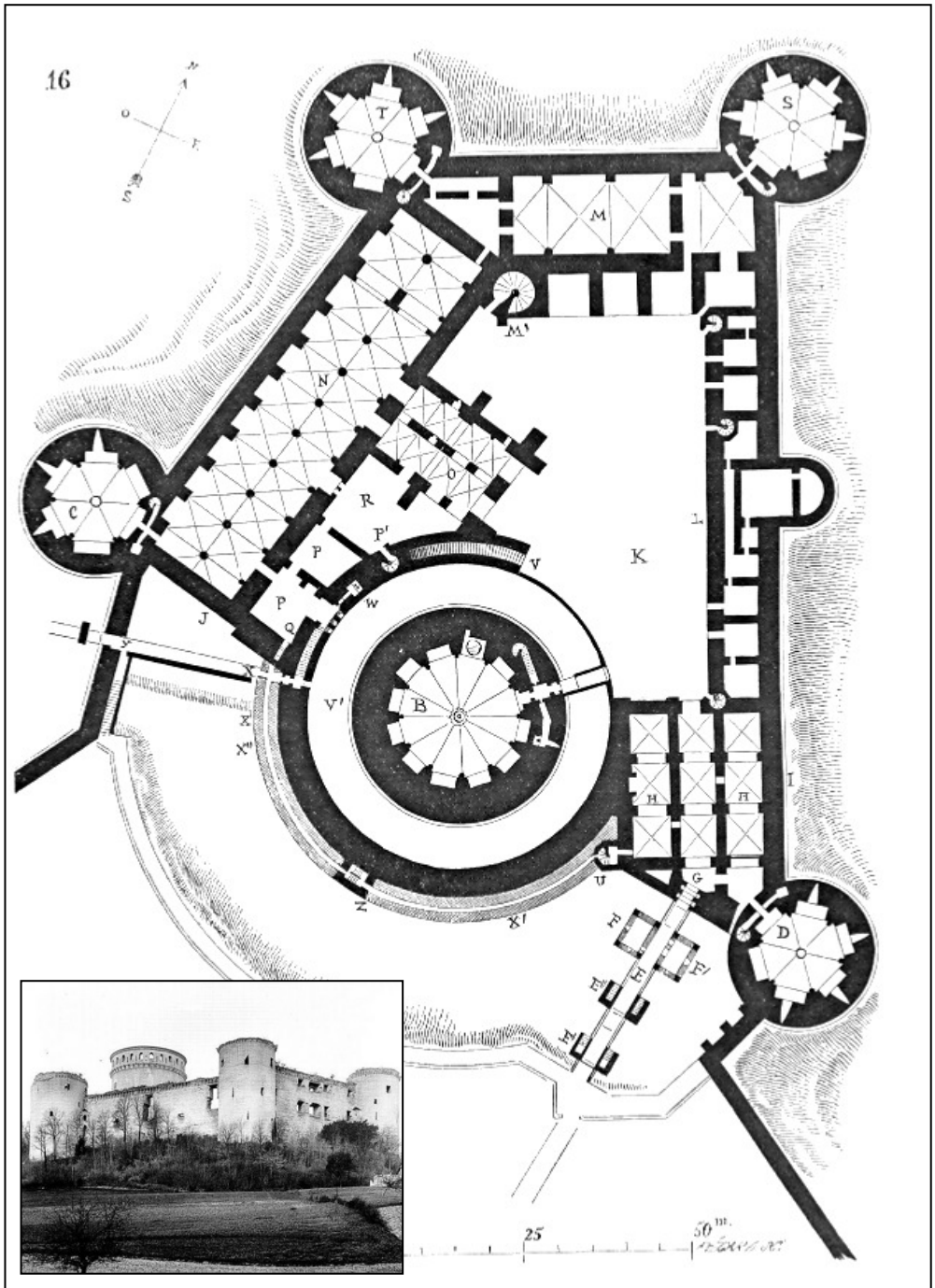

Fig. 84. Château de Coucy, Aisne, France, constructed in the 1220-32 by Enguerrand III de Coucy. The plan is from *Military Architecture of the Middle Ages*, 1860. Translated from the French of Viollet-le-Duc by M. Macdormott. p. 106. The Great Tower, B, Wall towers D, C, S, and T all have anticlockwise spiral stairs within the wall thickness. Fig. 85. Inset: Coucy Castle prior to its destruction in 1917. The great tower was twice the height of Pembroke.

The Rise of the Anti-clockwise Newel Stair - Conclusions



Fig. 86. Dover Castle. The broad and well-lit approach to the SW stair turret.

thing appears as if intended for a race larger than man... the risers of the steps are between 12 (30cms.) and 16 inches (41cms.) high'.¹ Other architectural design features similar to those seen at Coucy also appear in the 1230-40s castles of Henry III,² such as 'shouldered arches'. The introduction of the cut-slab newel stair seemed to have an effect on the size or length of the winder, either connected with the problems of sourcing quality freestone in sufficiently large quantities, or with concerns over the tensile strength of a monolithic stone block if taken to, say 1.5m. However, cut-slab winders remained in place as the standard method of stair construction until brick buildings became highly fashionable in the mid-fifteenth century.

There were two consequences of this technological change. First the 'Tonbridge style' gatehouses with their paired / mirrored 'ear' stair turrets were usually configured with both a clockwise and anticlockwise turret. This may have

¹ Viollet-le-Duc, E., 1860, pp. 112-3. Some of the highest tread risers in England are between 28-30 cms (11 inches), seen in Tonbridge gatehouse, c. 1260.

² See the full series of early monochrome photographs of Coucy, taken before its destruction in 1917 at: [www.flickr.com/search/?q=coucy castle](http://www.flickr.com/search/?q=coucy%20castle).



Fig. 87. Dudley Castle. A view of the anticlockwise newel rising from the basement into a small lobby. To the left is the start of the clockwise spiral up to the wall walk.

been a case of aesthetics, imitating cathedral transepts, but was more likely to have been a practical solution to facilitate and ease traffic flow by a one way system of circulation. Perhaps clockwise up and anticlockwise down. Secondly, it opened the way for a more relaxed decision-making process for the use of anticlockwise stairs in single towers with the ratio of ACW to CW growing, even becoming something of a fashion statement in the early fourteenth century. Some oddities arose, for example the Dudley Castle tower on the motte, c. 1260,³ where there is an anticlockwise spiral stair from the basement to first floor entry level, and then a change in direction to a clockwise rotation from first floor to the wall-walk (Fig. 87).

The fourteenth century also saw some fundamental changes to the gatehouse, not so much in its general appearance, although octagonal forms become the standard, but certainly in function, when dual or single staircases were often located in one or both of the front turrets giving access to suites of high-status lodging. Stairs exclusively filling the front turret(s) really marked the end to any pretence of a defensive function. Nothing in England matches the transformation of the Louvre in 1364 when Raymond de Temple, master of works to Charles V, reworked the Louvre from a

³ Malcolm Hislop, 2010.

The Rise of the Anti-clockwise Newel Stair - Conclusions



Fig. 88. Penshurst Place. The Great Hall and staircase turret (left) leading to the State apartments. The stair turret is variously dated to either the 1340s or the 1430s.

medieval castle into a regal palace, and erected a 27ft (8.22m) diameter spiral staircase (*Le Grande Viz Neuve*). Viollet le Duc mentions that the dimensions of the largest treads were about 2m width, and the cut-slab stones required were so long, that Charles V was forced to buy coffin lids or tomb slabs from ancient tombs in the church of the Holy Innocents probably because the hard limestone quarries in Paris had been unable to provide the required number of pieces to the desired dimensions.¹ The one English castle of this period that contains a staircase of any significant architectural ambition and splendour is Penshurst Place c. 1340s or 1430s, where the stair rises from an oriel lobby at the high end of the Great Hall up to the state apartments or withdrawing chambers. This is a vaulted clockwise winding stair, but not turning around a newel. For the 1340s this would have been an unusually precocious and bravura feature where solid wall was gradually being dissolved by window (Fig. 88).²

¹ Viollet-le-Duc, E., 1860, *Dictionnaire Raisoné de l'architecture française du XIe au XVIe siècle*, Vol. V, *Escalier Intérieurs*.

² There is no unanimity on the dating of the staircase. John Goodall considers it be of the same period as the Great Hall, c. 1340s, *Country Life*, Feb. 2nd, 2011, pp. 38-45, and Anthony Emery argues for a 1430-35 date

The fifteenth century saw the renewal of the ideal that great towers were a fitting symbol of lordly power and a visual focus for an aristocratic residence. Allied to this were changes in medieval society leading to an emphasis on new suites of accommodation. Brick became a *de facto* standard for the *nouveaux riches*, and was taken up by Lord Cromwell, William Lord Hastings, and the Bedingfields amongst others. This material demanded a fundamental change back to vaulted staircase construction, allowing brickmakers to demonstrate their consummate skills. Staircases regained their spaciousness and width not seen since the early Norman examples, and the stair slowly became a key domestic architectural feature of display that could add elegance, dignity and drama as one advanced to the Great Hall, or audience chamber.

In the sixteenth century the robust containing walls of helical stair turrets were eventually replaced by the flimsiest of open structural cages. Turret walls become nothing more than a supporting skeletal framework matching the general

(*GMH III*, pp. 386-94). Irrespective of the actual date, whilst stylistically the exterior of the staircase is of a piece with the original work of the hall, it may be a later addition executed in an historicist fashion, expertly constructed to appear to be original work.

The Rise of the Anti-clockwise Newel Stair - Conclusions



Fig. 89. Château Blois. Not the Renaissance stair, but a late-medieval anticlockwise stair in the Louis XII wing of the same building. Drawing by Sidney Toy, 1906, marked 'Escalier à Droite'. Built at the very end of the 15th century. Reproduced by courtesy of Sidney Toy's family.

Gothic motif and emphasis of general wall dissolution. The solid central newel is similarly dissolved into a hollow shaft or open frame. Early grandiose examples of the *escaliers monumental* include the staircases at Château Blois, of Louis XII (Fig. 89) and Francis I, c. 1515-25, the latter possibly conceived by either Leonardo da Vinci or Domenico di Cortone, and the swagger double-helix stair at Chambord, c. 1520-47, both the

product of Italianate Renaissance influence. These open-well stairs finally become liberated from their enclosures. The view from the stair is outward rather than inward towards enclosing walls. The first example in England of a deliberately articulated great stair is at Henry VII's Richmond Palace (1497-1504, demolished). The solid newel 'great stair' was finally eclipsed, to remain only as a humble service stair well behind the green baize door.

The Rise of the Anti-clockwise Newel Stair - Appendix 1.

Appendix 1								
English, Welsh & Irish castles - Spirals: Recorded Tread /Winder widths and Riser heights.								
Castle	Date	Element	Vault or CS.	Rotation	Winder Width (m)	Riser ht. (cms)	Staircase Diameter	Fore-bldg
Colchester	1070s	Main SE stair	V	CW	2.15	20	5.0m	•*
Colchester	1070s	Second NE stair	V	CW	1.61	20	3.6m	
White Tower	1080s	Main NE stair	V	CW	1.4	20	3.6m	•*
White Tower	1080s	Second NW stair	V	ACW	1.21	20	3.2m	
Norwich	1095	Main NE stair	V	ACW	0.86/97	20	2.3m	•
Norwich	1095	Second SW stair	V	ACW	0.86/97	20	2.3m	
Newark	1130s	GH Single turret	V	ACW	1.57	21		
Rochester	1130s	NE Main stair	V	CW	1.47	19	3.35m	•
Rochester	1130s	SW Second stair	V	CW	1.47	19	3.35m	
Kenilworth	1130s	GT single	V	CW	1.37	20	3.0m	•
Brandon	1130s	GT single	V	ACW	1.37	?	3.0m	
Hedingham	1140s	GT Single	V	CW	1.6	21	4.25m	•*
Castle Rising	1140s	NE Main Stair	V	CW	1.02	17-18	2.14m	•
Castle Rising	1140s	SW Second stair	V	CW	1.02	17-18	2.14	
Castle Rising	1140s	Grand Stair	Partly V	Straight	2.51 m	18	N/A	
Goodrich	1150s	GT Single	V	ACW	0.7	21	1.7m	
Orford	1170s	GT Single	V	CW	1.67	18	3.7m	•
Conisbrough	1180s	GT Mural	V	Mural	1.42	21	N/A	•
Dover	1180s	GT NE Main Stair	V	CW	1.9/1.8	19	4.58m	•
Dover	1180s	GT SW Secondary	V	CW	1.9/1.8	19	4.58m	
Middleham	1180s	GT single	V	CW	2	21		•*
Carrickfergus	1180s	GT Main Stair	CS	CW	0.84	21		
Dover	1220s	Constable's Gate	CS	ACW	0.8	20	1.85m	
Clifford's Tower	1250s	GT twin	CS	ACW	0.9	20		
Pembroke	1250s	GH twin	V	CW/ACW	X	X		
Dudley	1260s	GT Single	CS	ACW	X	X		
Tonbridge	1260s	GH twin	CS	CW/ACW	1.12	28-30		
Tower of London	1270s	Byward Tower	CS	ACW	1.17	19		
Caerphilly	1270s	GH Inner W twin	CS	CW/ACW	1.11	18		
Caerphilly	1270s	GH Inner E twin	CS	CW/ACW	1.47	19		
Newark	1300	West front middle	CS	ACW	0.75	21		
Kenilworth	1310	Water Tower	CS	ACW	1.21	18.5		
Kenilworth	1310	Lunn's Tower	CS	ACW	0.82	23		
Goodrich	1310s	GH single	CS	CW	1.2	18.4		
Boarstall Tower	1312	GH twin	CS	CW/CW	0.92	18.5		
Caerphilly	1320s	Outer Main gate	CS	CW	1.6	19		
Maxstoke	1340s	GH (twin)	CS	ACW	1.07	25		
Kenilworth	1370s	Strong Tower	CS	ACW	0.84	23		
Kenilworth	1370s	Saintlowe Tower	CS	ACW	0.83	23		
Bolton	1380s	Various	CS	ACW	X	X		
Tattershall	1440s	GT single SE	CS	CW	1.32	18		
Kirby Muxloe	1480s	GH twin	BV	CW/ACW	1.18	21		
Oxburgh Hall	1480s	GH single	BV	ACW	1.14	20		

GH=Gatehouse, GT=Great Tower, Twin= paired /mirrored turrets. BV=brick vault. CS=cust slab. V=stone vault * forebuilding added to the Great Tower later

The Rise of the Anti-clockwise Newel Stair - Acknowledgements

Acknowledgements.

When visiting various sites in the course of this research I would like to thank the following individuals or organisations for their cooperation and kindness:

At Dover, Wendy Richardson, Joanne Gray and Rowena Willard-Wright of English Heritage, and Corporal Netra of the MoD for access to the Constable's Gate complex.

At Rochester, Richard Eales.

At Newark, Rene Mourailles

At Norwich, Brian Ayers.

At Kenilworth, Holly Woodward.

At the Tower of London: Jeremy Ashbee, Dr. Jane Spooner and Dr. Sally Dixon-Smith, particularly during the course of the CSG visit in April.

At Newark, Clifford's Tower - York, Castle Rising and Oxburgh Hall, Philip Davis

At Colchester, Paul Sealey.

At Maxstoke, Michael Fetherston-Dilke.

For Hedingham, Orford, the Tower of London Colchester, and other places the CSG organising members of the April conference: Jeremy Cunningham, Charles Hollwey and Peter Purton.

Others have helped or responded with vital information on one or more sites:

Pamela Marshall on Newark and information about various French *donjons*.

Tom McNeill on Carrickfergus.

Gillian Eadie on Irish tower houses.

Anthony Emery on Brandon and other helpful comments.

Neil Ludlow on Pembroke.

Richard Morris on Kenilworth.

Rob Dixon on Boarstall Tower

Brian Hodkinson on Limerick

Malcolm Hislop on Dudley.

Derek Renn on Tonbridge.

John Goodall on Penshurst and Dover

Jonathan Coad on Dover

Jeremy Ashbee on Goodrich.

Geoffrey Stell on Bothwell and Dirleton.

For offering valuable comments on the draft or various parts of it I would like to thank Pamela Marshall, John Kenyon and in particular, Derek Renn, for his ideas, for his forensic analysis of the text and his continued lively interest in the subject.

Photographic and Image credits.

All the images are © copyright of the author with the following exceptions:

Figures:

5. *The White Tower. Upper floor plan.* © English Heritage.

9. *Ground floor plan of Norwich Castle* © Paul Drury.

12. *Newark Castle, gatehouse plan,* © Newark Castle Trust.

13. *Newark Castle, gatehouse. Detail from the Francis Frith photograph,* © Heritage Photographic Resources Ltd 2011.

18. *Brandon Castle, plan.* © Birmingham Archaeological Society.

19. *Kenilworth Castle, plan,* © English Heritage .

20. *Brandon Castle,* © Anthony Emery.

30. *Appleby Castle, plan of keep* © Mike Salter.

31. *Dictionnaire raisonné de l'architecture française du XIe au XVIe siècle,* by Eugène Viollet-le-Duc, 1856. Vol. V. (Out of copyright).

32. *Dictionnaire raisonné de l'architecture française du XIe au XVIe siècle,* by Eugène Viollet-le-Duc, 1856. Vol. V (Out of copyright).

39. *Clifford's Tower. Ground-floor plan.* © English Heritage.

46.5. *Caernarfon Passage By 'Foucault',* Flickr.

67. *Boarstall Tower. Engraving by Michael Burghers, 1691. From the collection of Rob Dixon.*

68. *Belsay Castle, Northumberland. From 'An Account of Belsay Castle', by Sir Arthur Middleton, 1910. Reprinted by the Spreddon Press. 1990. (Image out of copyright).*

69. *Old Wardour Castle, 'Johnlamper',* Flickr.

81. Carrickfergus

82. Carrickfergus

83. *Siege_Chateau_Gaillard*

84. *Plan, Château de Coucy, Aisne, France. Military Architecture of the Middle Ages, 1860. Translated from the French of Viollet-le-Duc by M. Macdermott. p. 106. (Image out of copyright).*

89. *Château Blois - Escalier a droit.* From the family of Sidney Toy.

Philip Davis for supplying the following: Figs: 33.4 Orford, 34.1, Scarborough 34.2, Middleham, 34.3 Conisbrough, 66.1-4 Bolton.

The Rise of the Anti-clockwise Newel Stair - Bibliography

- Alcock, N. W., Faulkner, P. A., and Jones, S., 1978, 'Maxstoke Castle, Warwickshire' in *The Archaeological Journal* Vol. 135, pp. 195-233.
- Anon, *Bolton Castle, Wensleydale*, (Official Guidebook), Leyburn, Bolton Castle, c. 2000.
- Ashbee, Jeremy., *Goodrich Castle*, English Heritage, London, 2005.
- Ashbee, Jeremy., *Conwy Castle*, Cadw, Cardiff, 2007.
- Austin, D., *Acts of Perception: A Study of Barnard Castle in Teesdale*, English Heritage and the Architectural and Archaeological Society of Durham and Northumberland, Research Report 6. Vol. I & II, 2007, pp. 166-171, 260.
- Avent, R., *Criccieth Castle*, Cadw, Cardiff, 1989.
- Avery, Tracey, *Tattershall Castle*, The National Trust, London, 1997.
- Bedingfield, Henry, *Oxburgh Hall, The First 500 Years*, National Trust / Jarrold, Norwich, 1982.
- Braun, Hugh., *Bungay Castle: Historical Notes and Account of the Excavations*, Bungay Castle Trust, Bungay, 1991.
- Braun, Hugh., *English Medieval Architecture*, Bracken Books, London, 1985. (reprint).
- Braun, Hugh, *The English Castle*, B. T. Batsford, London, revised 3rd ed., 1948.
- Brown, R. Allen., *English Castles*, B. T. Batsford, London, 1976.
- De Caumont, M. A., *Abécédaire ou Rudiment D'archéologie*, Vol. II, Architectures Civile et Militaire., 3rd edition, LBH, Caen, 1853.
- Chatwin, P. B. 'Brandon Castle, Warwickshire,' *Proceedings & Transactions of the Birmingham Archaeological Society* 73, (1955), pp. 63-83.
- Clark, G. T., *Mediaeval Military Architecture in England*, Vols. 1 & 2. Wyman Ltd, London, 1884.
- Clark, Jonathan., *Clifford's Tower and the Castle of York*, English Heritage, London, 2010.
- Coad, Jonathan., *Dover Castle and the Defences of Dover*, B.T. Batsford / English Heritage, London, 1995.
- Coad, Jonathan., *Dover Castle*, English Heritage, London, 2007.
- Colvin, H. M., (Gen. ed.) *The History of the King's Works*, Vol I, II, The Middle Ages (1963), Vol. III and IV, 1485-1660, Parts I & II., (1975, 1982), HMSO, London.
- Cooper, Nicolas., *Houses of the Gentry 1480-1680.*, English Heritage / Yale Univeristy Press, New Haven & London, 1999.
- Crummy, Philip, 2002, 'New light on Colchester Castle' *The Colchester Archaeologist* Vol. 15 p. 8.
- Crummy, Philip, 2001, 'Colchester Castle measured up' *The Colchester Archaeologist* Vol. 14, pp. 21-22.
- Crummy, Philip, 1993-4, 'The castle that Eudo built' *The Colchester Archaeologist* Vol. 7 pp. 1-7.
- Curzon, N., and Tipping, H. A., *Tattershall Castle*, Lincolnshire, Jonathan Cape, London, 1929.
- Dept of the Environment., *The Tower of London, Official Handbook*, HMSO, London, 1974.
- Dixon, Philip., 'Design in Castle Building: The Control of Access to the Lord', in *Château-Gaillard 18*, 1998, pp. 47-57.
- Dixon, Philip., Marshall, Pamela., Palmer-Brown, Colin., Samuels, John., *Newark Castle Studies, Excavations 1992-1993.*, Newark Castle Trust, 1994.
- Dixon, Philip and Marshall, Pamela, 'The Great Tower at Hedingham Castle: A Reassessment', in A. D. Saunders (ed.) *Fortress*, 1993, Issue 18, pp. 16-23; reprinted in Robert Liddiard, (ed.), *Anglo-Norman Castles*, Boydell, Woodbridge, 2003, pp. 297-306.
- P. Dixon and P. Marshall, 'Norwich Castle and its Analogues', in *The Seigneurial Residence in Western Europe. AD c. 800-1600*, ed. G Merion-Jones, E. Impey and M. Jones, British Archaeological Reports International Series 1088, Oxford, 2002, pp. 235-43.
- Dixon, Rob., *Boarstall Tower*, The National Trust, London, 2009.
- Drury, P. J., 'Aspects of the origins and development of Colchester Castle' in *The Archaeological Journal* Vol. 139 (1982), pp. 302-419.
- Drury, P. J. 'Norwich Castle Keep', in *The Seigneurial Residence in Western Europe. AD c.800-1600*, ed. G Merion-Jones, E. Impey and M. Jones, British Archaeological Reports International Series 1088, Oxford, 2002, pp. 211-24.
- Eales, R., 'Royal Power and Castles in Norman England', in C. Harper-Bill and R Harvey (eds.) *Medieval Knighthood 3*, 2003, Boydell, Woodbridge, pp. 49-78. Reprinted in R. Liddiard (ed.) *Anglo-Norman Castles*, Boydell, Woodbridge,

The Rise of the Anti-clockwise Newel Stair - Bibliography

- Emery, A., *Greater Medieval Houses of England and Wales 1300-1500*: Vol I, 1996, Vol II, 2000, Vol. III, 2006, Cambridge University Press, Cambridge.
- Faulkner, P. A., 'Domestic Planning from the 12th to the 14th Century', *Archaeological Journal*, Vol. 115 (1958), pp. 150-183.
- Fernie, E., *The Architecture of Norman England*, Oxford University Press, Oxford, 2000.
- Fisher, E. A., *The Greater Anglo-Saxon Churches - An Architectural-Historical Study*, Faber and Faber, London, 1962.
- Friar, Stephen, *The Sutton Companion to Castles*, The History Press, Stroud, 2007.
- Garnett, Oliver, *Oxburgh Hall*, The National Trust, London, 2000.
- Gomme, Andor., & Maguire, Alison, *Design and Plan in the Country House - From Castle Donjons to Palladian Boxes*, Yale University Press, New Haven and London, 2008.
- Goodall, John, A. A., 'A Merchant's Palace' (Penshurst Place), in *Country Life*, Feb. 2nd, 2011, pp. 38-45.
- Goodall, John A. A., *The English Castle 1066-1650*, Yale University Press, New Haven and London, 2011.
- Harvey, John, H., *Henry Yevele c. 1320-1400, The Life of an English Architect*, B. T. Batsford, London, 1944.
- Heslop, T. A., *Norwich Castle Keep: Romanesque Architecture and Social Context*, Centre of East Anglian Studies, University of East Anglia, Norwich, 1994.
- Heslop, T. A., 'Orford Castle: Nostalgia and Sophisticated Living', in *Architectural History*, Vol. 34, (1991), pp. 36-58, reprinted in Robert Liddiard (ed.), *Anglo-Norman Castles*, Boydell, Woodbridge, 2003, pp. 273-96.
- Hislop, Malcolm., 'A Missing Link: a Reappraisal of the Date, Architectural Context and Significance of the Great Tower of Dudley Castle', in the *Antiquaries Journal*, Vol. 90, (2010), pp. 211-233.
- Howard, Maurice., *The Early Tudor Country House*, George Philip, London, 1987, pp. 83-88
- Impey, Edward (ed.), *The White Tower*, Yale University Press, New Haven & London, 2008.
- Innes-Smith, Robert., *Heddingham Castle, Essex*, Official Guide, English Life Publications, Derby, 2000.
- Kenyon, J. R., & Avent, R., (eds.) *Castles in Wales and the Marches*, University of Wales Press, Cardiff, 1987.
- Kenyon, J. R., *The Medieval Castles of Wales*, University of Wales Press, Cardiff, 2010.
- King, D. J. C. *Llanstephan Castle*, Official Handbook, HMSO, Cardiff, 1977.
- Knight, J. K., *Bronllys Castle*, Welsh Office, Cardiff, 1981.
- Knight, J. K., *The Three Castles*, Cadw, Cardiff, 2009. (White, Grosmont and Skenfrith).
- Liddiard, Robert., *Castles in Context*, Windgather Press, Macclesfield, 2005.
- Lloyd, N., *A History of English Brickwork*, H Greville Montgomery, London, 1934. Reprinted by the Antique Collectors Club, London, 2003.
- Ludlow, Neil., 'Pembroke Castle and Town Walls', in A. Saunders (ed.), *Fortress*, February 1991, Issue 8, pp. 25-30.
- McNeill, T. E., *Carrickfergus Castle, Co. Antrim*, Northern Ireland Environment Agency, Monograph No 1. (1981), HMSO, Belfast.
- Mackay Mackenzie, W., *The Medieval Castle in Scotland*, Methuen, London, 1927.
- Marshall, Pamela., 'The Great Tower as Residence', in Gwyn Meirion-Jones, Edward Impey, Michael Jones (eds.), *The Seigneurial Residence in Western Europe AD c. 800-1600*, BAR International Series 1088, 2002, pp. 27-44.
- Marshall, Pamela and Samuels, John., *Guardian of the Trent - The Story of Newark Castle*, Newark Castle Trust, 1997.
- Marshall, Pamela, 'The internal arrangement of the donjon at Colchester in Essex: a reconsideration', *Castle Studies Group Journal*, Vol. 23, 2009-10, pp. 178-90.
- Matarasso, François., *The English Castle*, Cassell, London, 1993.
- Mesqui, J., *Châteaux et enceintes de la France médiévale*, 2 Vols., Picard, Paris, 1991, 1993.
- Mesqui, J., *Châteaux forts et fortifications en France*, Flammarion, Paris, 1997.
- Morris, Richard, K., *Kenilworth Castle*, English Heritage, London, 2010.
- Morris, Richard K., 'I was never more in love with an olde house nor never newe work could be

The Rise of the Anti-clockwise Newel Stair - Bibliography

- better bestowed': The Earl of Leicester's remodeling of Kenilworth Castle for Queen Elizabeth I', in *The Antiquaries Journal*, 89 (2009), pp. 241-305.
- National Trust (anon.), *Tattershall Castle*, The National Trust, London, 1981.
- Parker, J. H., *Some Account of Domestic Architecture in England*, Vol. II, from Edward I to Richard II (1853), Vol. III pts I & II from Richard II to Henry VIII (1859), J H Parker, Oxford. See also Turner.
- Parnell, Geoffrey., *The Tower of London*, English Heritage/ B. T. Batsford, London, 1993.
- Peers, Sir Charles., *Kirby Muxloe Castle*, HMSO, London, 1975.
- Reeve, Christopher., *Bungay Castle Guide*, Bungay Castle Trust, 2001.
- Renn, D. F., 'Tonbridge and Some Other Gate-houses' in *Collectanea Historica: Essays in Memory of Stuart Rigold*, A Detsicas (ed.), Maidstone, 1981, pp. 93-103.
- Renn, D. F., *Norman Castles in Britain*, John Baker (A & C Black), London, 1968.
- Renn, D. F., *Caerphilly Castle*, Cadw, Cardiff, 1997.
- Renn, D. F, and Avent, R., *Flint and Ewloe Castles*, Cadw, Cardiff, 2001.
- Rhodes, John., *Orford Castle*, English Heritage London, 2003.
- Royal Commission: York Castle*, RCHM (England), 1973. (Clifford's Tower). (Off-print from the Royal Commission's 2nd inventory of the monuments of York - *The Defences*), HMSO, London, 1972.
- RCAHMW., *An Inventory of the Ancient Monuments in Glamorgan, Vol. III - Part 1b. Medieval Secular Monuments: The Later Castles from 1217 to the Present*, Aberystwyth, 2000.
- Simpson, W. D., *Castles in England and Wales*, B. T. Batsford., London, 1969.
- Simpson, W. D., *The Building Accounts of Tattershall Castle 1434-72*, Lincoln Record Society LV, 1960.
- Summerson, Henry., *Warkworth Castle*, English Heritage, London, 1995.
- Taylor, A., *Caernarfon Castle*, Cadw, Cardiff, 2004.
- Taylor, A., *Beaumaris Castle*, Cadw, Cardiff, 2004.
- Templer, John., *The Staircase, History and Theories*, MIT Press, Cambridge Mass. and London 1992.
- Thompson, A, Hamilton., *Military Architecture in England During the Middle Ages*, Henry Frowde/ OUP, 1912.
- Thompson, M. W., *Kenilworth Castle*, HMSO, 1980.
- Thompson, M. W., *The Decline of the Castle*, Cambridge University Press, Cambridge, 1987.
- Thompson, M. W., *The Rise of the Castle*, Cambridge University Press, Cambridge, 1991.
- Toy, Sydney., *The Castles of Great Britain*, Heinemann, London, 1953.
- Toy, Sydney, *A History of Fortification from 3000BC to AD 1700*, Heinemann, London, 1955.
- Turner, T, Hudson., *Some Account of Domestic Architecture in England*, I, From the Conquest to the end of the 13th century, J H Parker, Oxford, 1851. For Vols. II & III see Parker, J. H.
- Viollet-le-Duc, Eugène., *Dictionnaire raisonné de l'architecture française du XIe au XVIe siècle*, 1856. Vol. V, pp. 296-8.
- Viollet-le-Duc, Eugène., *Military Architecture of the Middle Ages*, J H & J Parker, Oxford and London, 1860.
- White, Roger., *Belsay Hall, Castle and Gardens*, English Heritage, London, 2005.
- Whiteley, M., 'The Courts of Edward III of England and Charles V of France: A Comparison of their Architectural Setting and Ceremonial Functions', in *Fourteenth Century England, I*, Nigel Saul (ed.), Boydell, 2000.
- Williams, Diane, M., Kenyon, John R., (eds.) *The Impact of the Edwardian Castles in Wales.*, Oxbow Books, Oxford, 2010.
- Wood, Margaret., *Donnington Castle*, HMSO, London, 1964.
- Wood, Margaret, *The English Mediaeval House*, Bracken Books, 1985, a reprint of the Phoenix House, London, ed. of 1965.
- Wood, Margaret., *Norman Domestic Architecture*, Royal Archaeological Inst., London, 1974.
- Yarrow, Anne, *Corfe Castle*, The National Trust, London, 2003.