

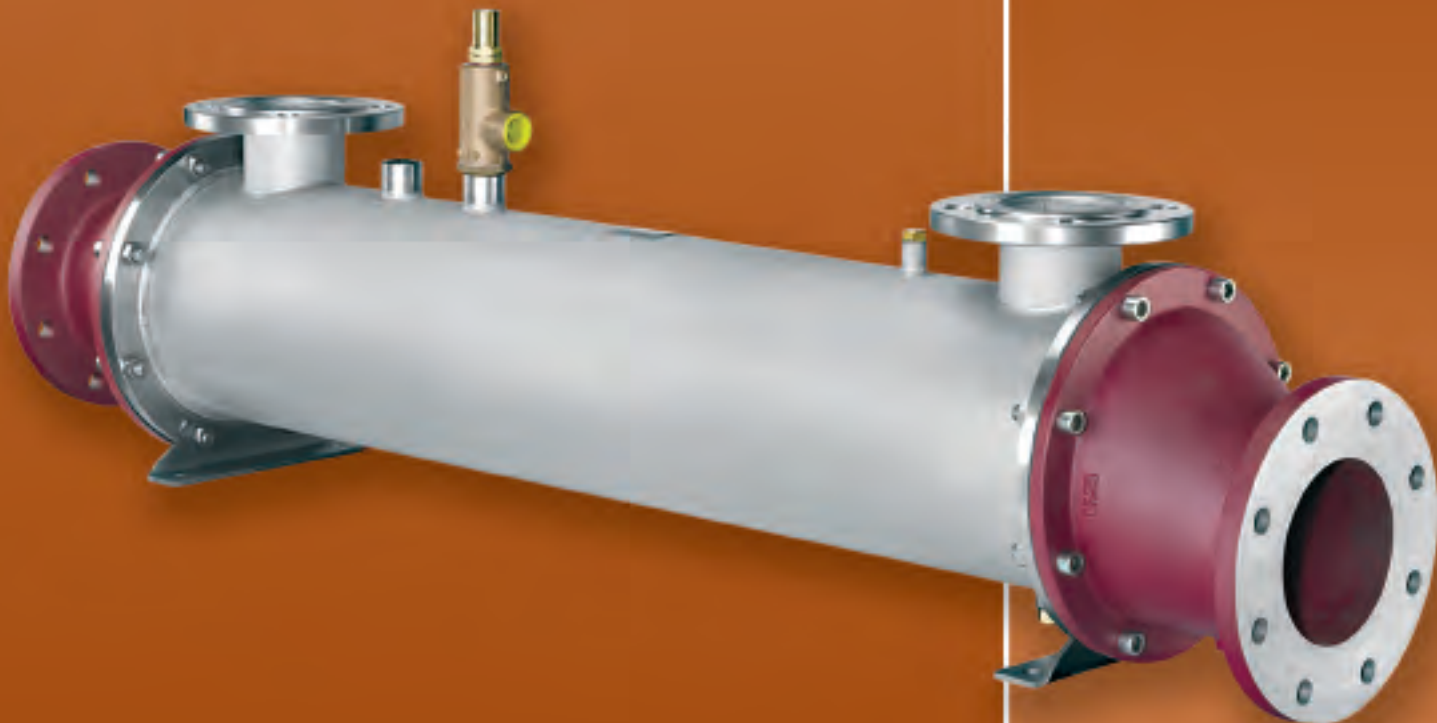

# Exhaust Gas Heat Exchangers

Scambiatori di calore per gas di scarico

Abgaswärmetauscher



## Exhaust Gas Heat Exchangers

These heat exchangers are designed to remove thermal energy from the exhaust gas of natural gas, diesel and bio-fuel engines and transfer it to the water circuit. The extracted heat can be used for space heating, domestic hot water and any industrial process that requires hot water.

- Standard range available for quick delivery.
- Suitable for engines up to 1MW.
- Suitable for use with engines powered by conventional or alternative fuels.
- Fully welded stainless steel construction for reliability and durability.
- Can also be used to extract energy from gas or air and transfer it to a water circuit.
- Compact and efficient design for ease of installation.
- Ideal for reducing the exit temperature of the exhaust gases in hazardous areas.
- Used in conjunction with jacket water, charge air, fuel and oil coolers, Bowman units can reclaim up to 60% of waste heat from an engine.
- Bowman units when fitted provide **FREE HEATING & HOT WATER.**

Given the following information, we can recommend a unit for your requirements:

Fuel type

Exhaust gas mass flow rate

Exhaust gas inlet temperature

Water circuit inlet temperature and flow rate



Automated tube end welding  
and 100% inspection



# Combined Heat Recovery

The addition of Bowman exhaust gas heat exchangers enable waste heat recovery from the exhaust gas and can be used on Cogeneration/Combined Heat and Power (CHP) equipment.

## Typical configuration for CHP using Bowman Heat Exchangers

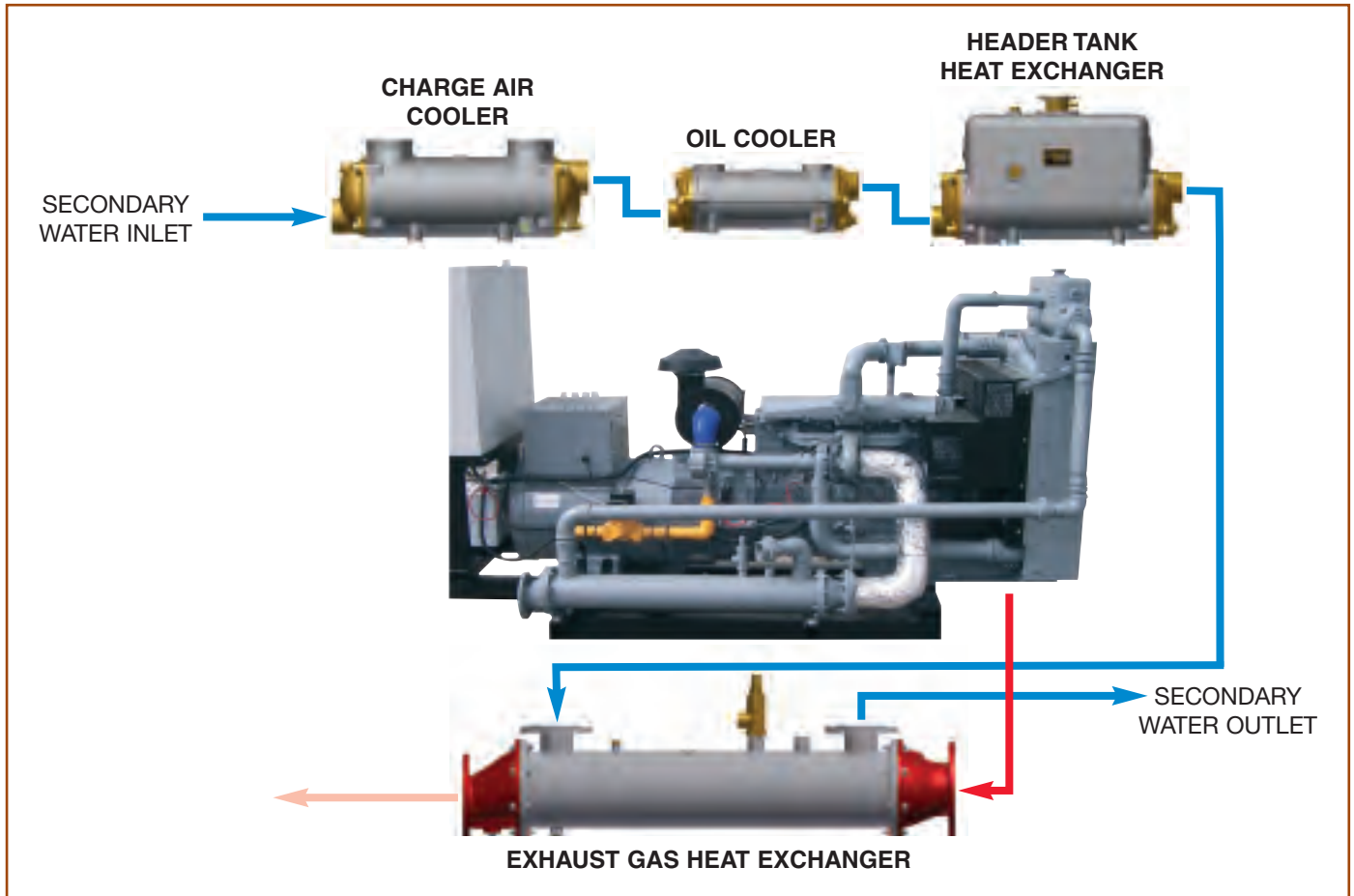

Provision should be made for cooling the engine water, oil and gas when heat recovery is not required.

## Combined Heat Recovery Performance Table

This table shows the heat that can be removed from each type of heat exchanger as shown in the illustration above.

Type	Engine Power kW	Jacket Water kW	Engine Oil kW	Charge Air Cooler kW	Exhaust Gas kW	Total Reclaimed Energy kW
2"	16	5	2	2.5	11.5	20.5
3"	32	10	4	5	23	41
4"	60	18	7	9	43	77
5"	90	27	10	14	65	115
6"	140	42	15	21	101	179
8"	250	75	28	38	181	321
10"	400	120	44	60	288	512
12"	600	180	66	90	425	761
15"	950	280	104	142	670	1205

The above figures should be used as a guide only, optimised design is available on request.

## Exhaust Gas Heat Exchanger Performance Table

### Typical examples of exhaust gas heat exchanger performance

The figures below are a general guide only and are not based on any particular natural gas engine. They assume an air/fuel ratio of 10.23 : 1 by volume, a fuel consumption of 0.34m<sup>3</sup>/kWh (measured at 1.013 bar and 15°C) and an exhaust gas temperature of 600°C and a water inlet temperature of 80°C.

Type	Typical Engine Power kW	Exhaust gas flow kg/min	Exhaust gas outlet temp °C	Heat recovery kW	Exhaust gas pressure drop kPa
2-25-3737-4	16	1.2	210	9.5	1.6
2-32-3737-5	16	1.2	170	11.5	1.8
3-32-3738-5	32	2.4	210	19	1.5
3-40-3738-6	32	2.4	170	21	1.7
3-60-3738-8	32	2.4	120	23	2.2
4-32-3739-5	60	4.5	210	35	1.3
4-40-3739-6	60	4.5	170	39	1.4
4-60-3739-8	60	4.5	120	43	1.8
5-32-3740-5	90	6.7	210	53	1.2
5-40-3740-6	90	6.7	170	58	1.4
5-60-3740-8	90	6.7	120	65	1.8
6-32-3741-5	140	10.5	210	82	1.3
6-40-3741-6	140	10.5	170	90	1.4
6-60-3741-8	140	10.5	120	101	1.9
8-32-3742-5	250	18.7	210	147	1.3
8-40-3742-6	250	18.7	170	161	1.4
8-60-3742-8	250	18.7	120	181	1.8
10-32-3743-5	400	30.0	210	236	1.3
10-40-3743-6	400	30.0	170	256	1.4
10-60-3743-8	400	30.0	120	288	1.8
12-32-3744-5	600	45.0	210	353	1.3
12-40-3744-6	600	45.0	170	388	1.5
12-60-3744-8	600	45.0	120	425	1.9
15-40-5745-6	950	70.0	170	604	1.4
15-60-5745-8	950	70.0	120	670	1.9

For larger sizes contact our sales department.

100kPa = 1 bar

Maximum working gas side pressure 0.5 bar  
 Maximum working water side pressure 4 bar  
 Maximum working gas side temperature 700°C  
 Maximum working water side temperature 110°C

### European Pressure Equipment Directive

This range of products fall within Article 3 Paragraph 3 (Sound Engineering Practice) and do not require CE marking.

## Exhaust Gas Heat Exchangers

There are three ranges of Bowman exhaust gas heat exchangers, without end covers for connection directly to customer's pipework (see page 5), straight end covers with PN6 flange connections (see page 6) and 90° end covers with PN6 connections and removable end plates for maintenance (see page 7). All models include a pressure relief valve as standard.

Shell side flanges are PN6 to BS EN1092 as are the straight and 90° end cover flanges. Tubeplate flange dimensions are shown in the table on page 5.

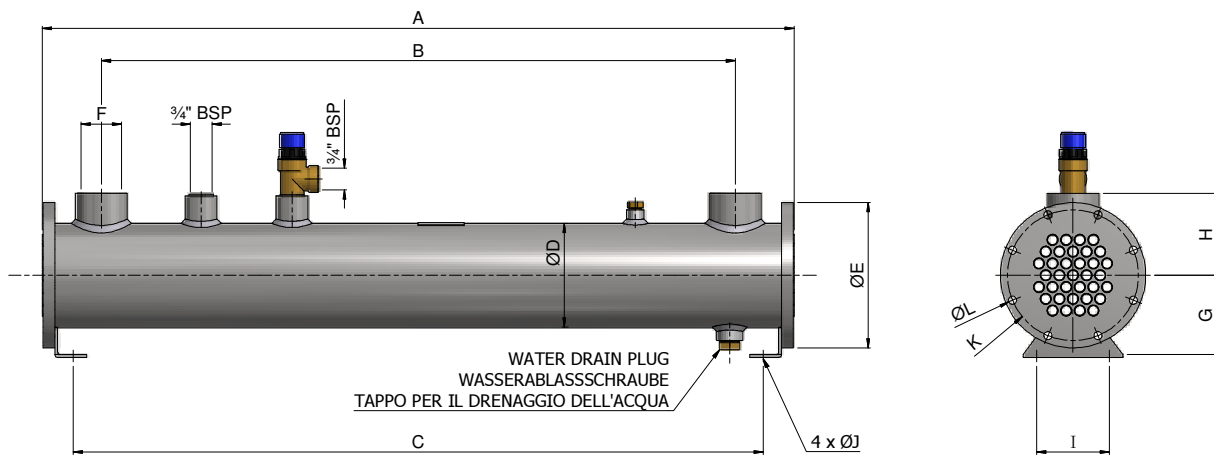

Type	A	B	C	D	E	F	G	H	I	J	K	L	kg
2-25-4737-4	648	550	588	60.3	106	3/4" BSP	65	55	60	9	90 PCD	4 x 9	7
2-32-4737-5	826	728	766	60.3	106	3/4" BSP	65	55	60	9	90 PCD	4 x 9	8
3-32-4738-5	826	718	760	88.9	136	1"	75	75	60	9	120 PCD	8 x 9	14
3-40-4738-6	1028	920	962	88.9	136	1"	75	75	60	9	120 PCD	8 x 9	17
3-60-4738-8	1536	1428	1470	88.9	136	1"	75	75	60	9	120 PCD	8 x 9	23
4-32-4739-5	826	698	760	114.3	160	1 1/2"	90	90	80	9	144 PCD	8 x 9	20
4-40-4739-6	1028	900	962	114.3	160	1 1/2"	90	90	80	9	144 PCD	8 x 9	23
4-60-4739-8	1536	1408	1470	114.3	160	1 1/2"	90	90	80	9	144 PCD	8 x 9	32
5-32-4740-5	826	688	760	141.3	194	2"	105	105	100	11	174 PCD	8 x 11	28
5-40-4740-6	1028	890	962	141.3	194	2"	105	105	100	11	174 PCD	8 x 11	32
5-60-4740-8	1536	1398	1470	141.3	194	2"	105	105	100	11	174 PCD	8 x 11	45

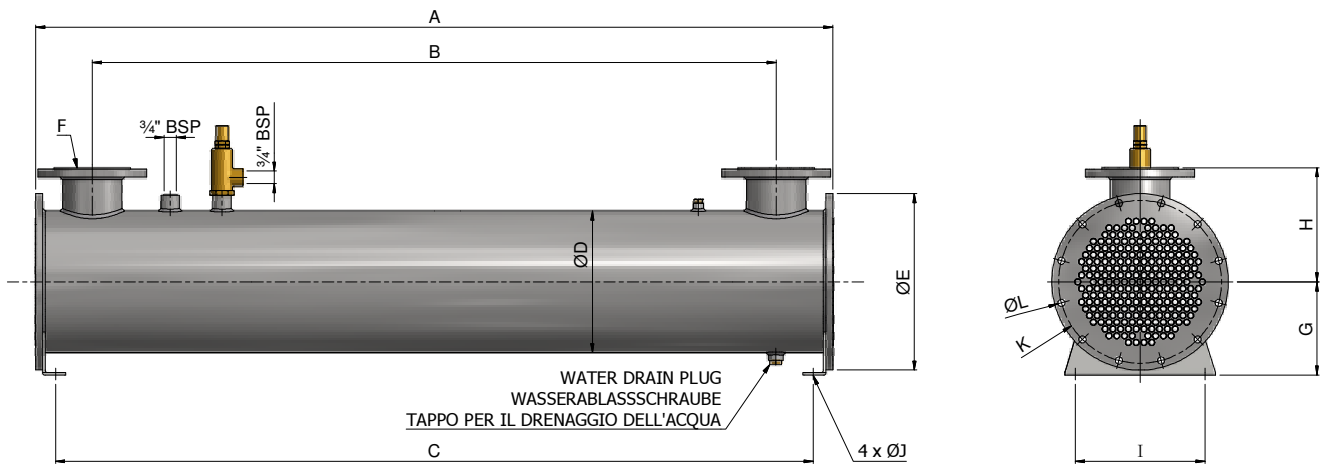

Type	A	B	C	D	E	F	G	H	I	J	K	L	kg
6-32-4741-5	826	668	760	168.3	220	DN65	120	140	130	11	200 PCD	8 x 11	40
6-40-4741-6	1028	870	962	168.3	220	DN65	120	140	130	11	200 PCD	8 x 11	47
6-60-4741-8	1536	1378	1470	168.3	220	DN65	120	140	130	11	200 PCD	8 x 11	65
8-32-4742-5	826	648	750	219	284	DN80	150	180	180	14	260 PCD	8 x 14	66
8-40-4742-6	1038	850	952	219	284	DN80	150	180	180	14	260 PCD	8 x 14	74
8-60-4742-8	1536	1358	1460	219	284	DN80	150	180	180	14	260 PCD	8 x 14	102
10-32-4743-5	826	608	750	273	340	DN100	180	220	250	14	314 PCD	12 x 14	94
10-40-4743-6	1028	810	952	273	340	DN100	180	220	250	14	314 PCD	12 x 14	108
10-60-4743-8	1536	1318	1460	273	340	DN100	180	220	250	14	314 PCD	12 x 14	148
12-32-4744-5	826	538	736	324	410	DN125	220	260	300	18	376 PCD	12 x 18	132
12-40-4744-6	1028	740	938	324	410	DN125	220	260	300	18	376 PCD	12 x 18	151
15-40-4745-6	1028	740	912	406.4	495	DN150	280	320	350	18	460 PCD	16 x 18	231
15-60-4745-8	1536	1248	1420	406.4	495	DN150	280	320	350	18	460 PCD	16 x 18	316

Flange 'F' to BS EN 1092-1:2007 - PN6.

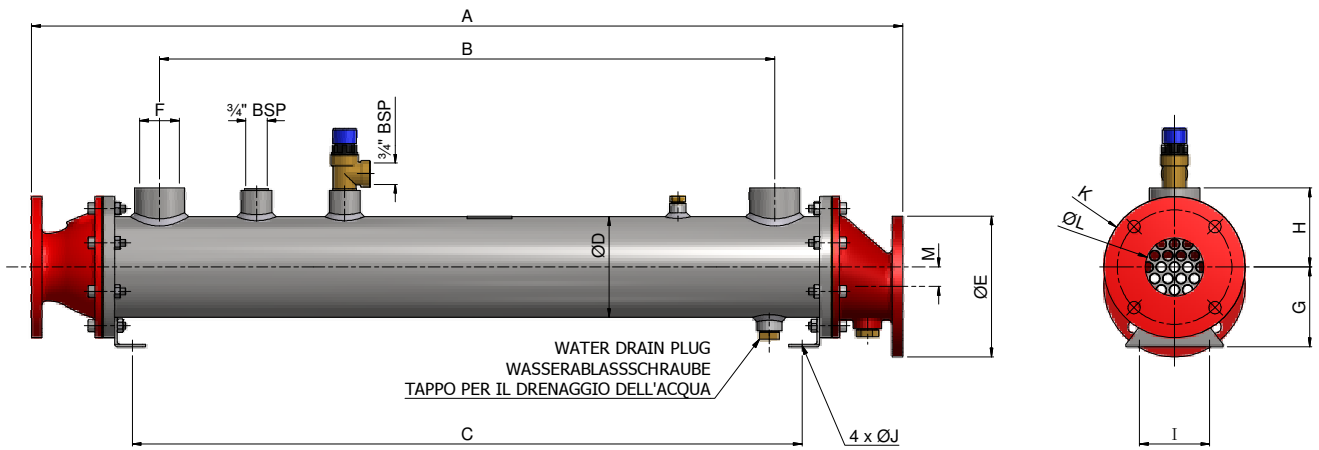

Type	A	B	C	D	E	F	G	H	I	J	K	L	M	kg
2-25-3737-4	750	550	588	60.3	100	BSP	65	55	60	9	DN25	34	12	10
2-32-3737-5	928	728	766	60.3	100	3/4"	65	55	60	9	DN25	34	12	12
3-32-3738-5	960	718	760	88.9	140	1"	75	75	60	9	DN50	54	16	18
3-40-3738-6	1162	920	962	88.9	140	1"	75	75	60	9	DN50	54	16	20
3-60-3738-8	1670	1428	1470	88.9	140	1"	75	75	60	9	DN50	54	16	27
4-32-3739-5	990	698	760	114.3	160	1 1/2"	90	90	80	9	DN65	66	22	25
4-40-3739-6	1192	900	962	114.3	160	1 1/2"	90	90	80	9	DN65	66	22	29
4-60-3739-8	1700	1408	1470	114.3	160	1 1/2"	90	90	80	9	DN65	66	22	40
5-32-3740-5	1030	688	760	141.3	190	2"	105	105	100	11	DN80	82	26	36
5-40-3740-6	1232	890	962	141.3	190	2"	105	105	100	11	DN80	82	26	39
5-60-3740-8	1740	1398	1470	141.3	190	2"	105	105	100	11	DN80	82	26	51

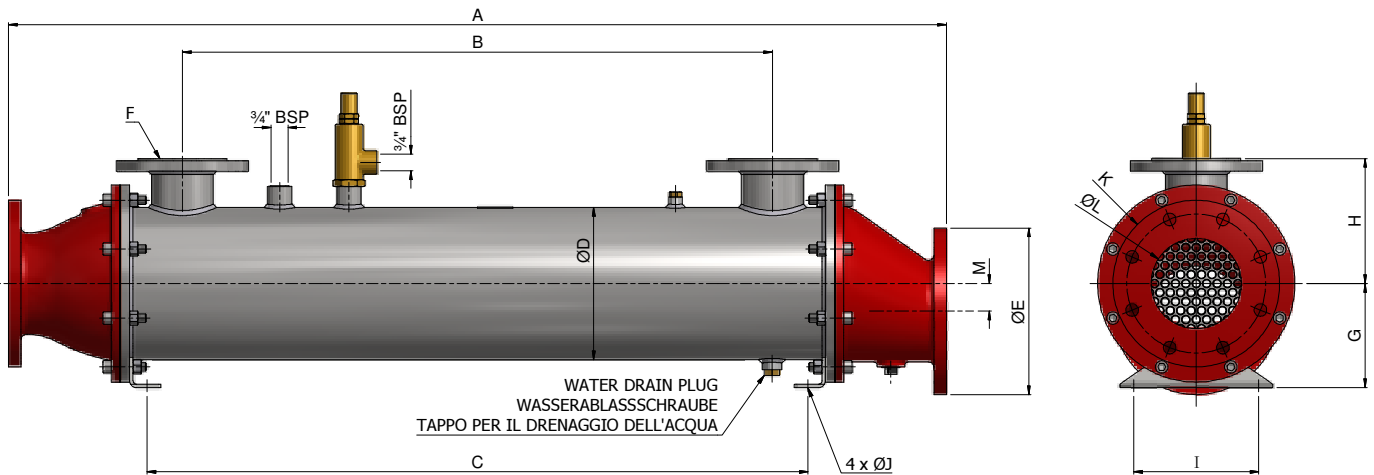

Type	A	B	C	D	E	F	G	H	I	J	K	L	M	kg
6-32-3741-5	1080	668	760	168.3	210	DN65	120	140	130	11	DN100	104	28	48
6-40-3741-6	1282	870	962	168.3	210	DN65	120	140	130	11	DN100	104	28	55
6-60-3741-8	1790	1378	1470	168.3	210	DN65	120	140	130	11	DN100	104	28	72
8-32-3742-5	1150	648	750	219	240	DN80	150	180	180	14	DN125	130	40	89
8-40-3742-6	1352	850	952	219	240	DN80	150	180	180	14	DN125	130	40	98
8-60-3742-8	1860	1358	1460	219	240	DN80	150	180	180	14	DN125	130	40	125
10-32-3743-5	1230	608	750	273	265	DN100	180	220	250	14	DN150	154	55	132
10-40-3743-6	1432	810	952	273	265	DN100	180	220	250	14	DN150	154	55	146
10-60-3743-8	1940	1318	1460	273	265	DN100	180	220	250	14	DN150	154	55	185
12-32-3744-5	1330	538	736	324	320	DN125	220	260	300	18	DN200	204	55	190
12-40-3744-6	1532	740	938	324	320	DN125	220	260	300	18	DN200	204	55	208
12-60-3744-8	2040	1248	1446	324	320	DN125	220	260	300	18	DN200	204	55	268
15-40-5745-6	1670	740	912	406.4	375	DN150	280	320	350	18	DN250	254	70	319
15-60-5745-8	2180	1248	1420	406.4	375	DN150	280	320	350	18	DN250	254	70	404

Flange 'F' to BS EN 1092-1:2007 - PN6.

Flange 'K' to BS EN 1092-1:2007 - PN6.

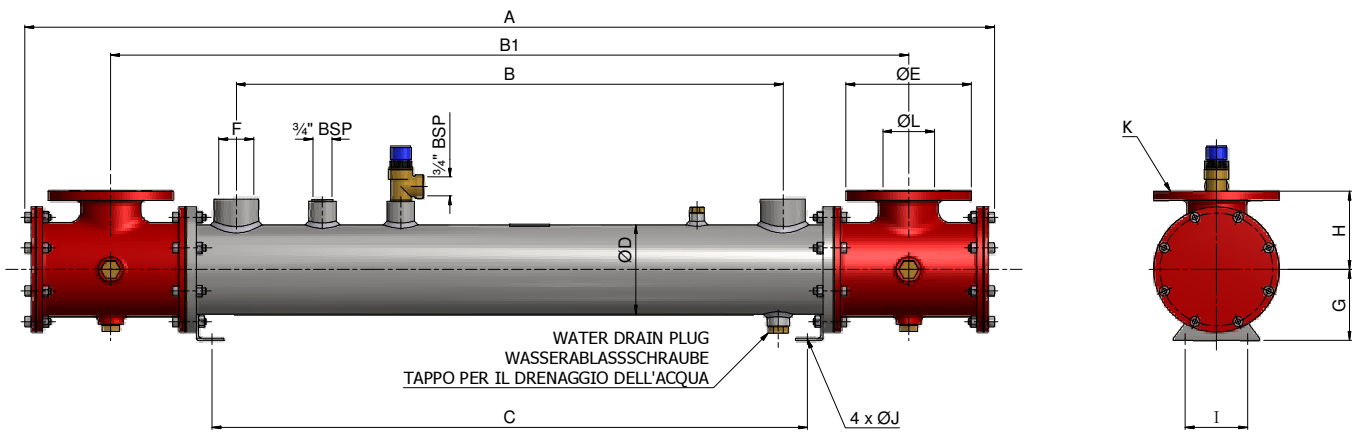

Type	A	B	B1	C	D	E	F	G	H	I	J	K	L	kg
2-25-5837-4	920	550	770	588	60.3	100	3/4"	65	70	60	9	DN25	34	13
2-32-5837-5	1098	728	950	760	60.3	100	3/4"	65	70	60	9	DN25	34	14
3-32-5838-5	1198	718	999	760	88.9	140	1"	75	85	60	9	DN50	54	24
3-40-5838-6	1400	920	1200	962	88.9	140	1"	75	85	60	9	DN50	54	27
3-60-5838-8	1908	1428	1708	1470	88.9	140	1"	75	85	60	9	DN50	54	33
4-32-5839-5	1237	698	1019	760	114.3	160	1 1/2"	90	100	80	9	DN65	66	33
4-40-5839-6	1439	900	1221	962	114.3	160	1 1/2"	90	100	80	9	DN65	66	37
4-60-5839-8	1948	1408	1729	1470	114.3	160	1 1/2"	90	100	80	9	DN65	66	46
5-32-5840-5	1306	688	1049	760	114.3	190	2"	105	120	100	11	DN80	82	51
5-40-5840-6	1504	890	1251	962	114.3	190	2"	105	120	100	11	DN80	82	55
5-60-5840-8	2010	1398	1759	1470	114.3	190	2"	105	120	100	11	DN80	82	68

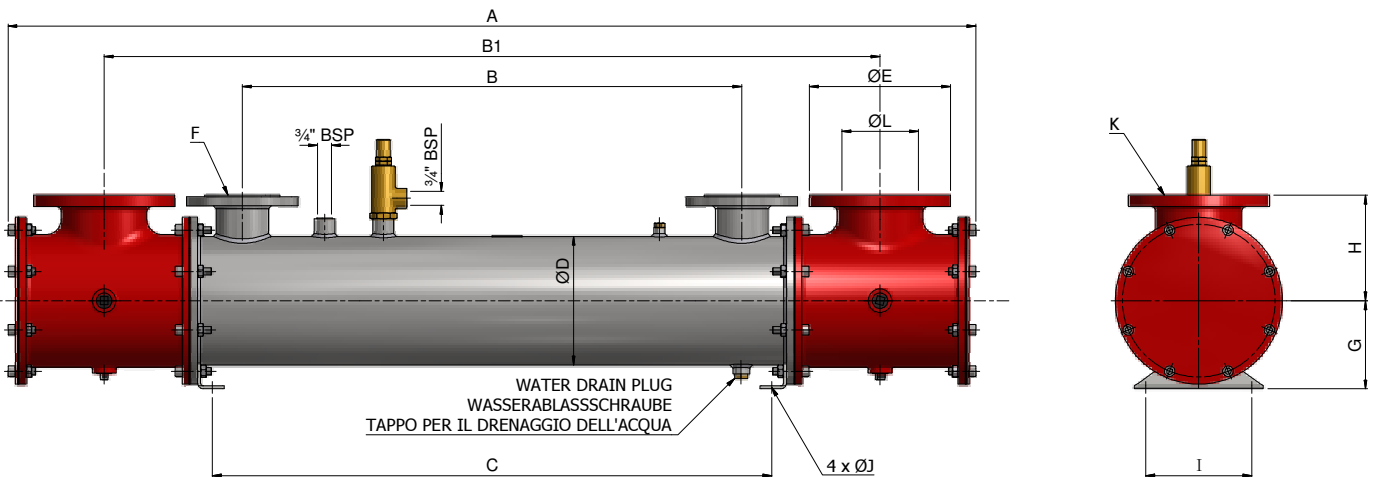

Type	A	B	B1	C	D	E	F	G	H	I	J	K	L	kg
6-32-5841-5	1400	668	1100	760	168.3	210	DN65	120	140	130	11	DN100	104	72
6-40-5841-6	1604	870	1302	962	168.3	210	DN65	120	140	130	11	DN100	104	79
6-60-5841-8	2110	1378	1810	1470	168.3	210	DN65	120	140	130	11	DN100	104	96
8-32-5842-5	1446	468	1120	750	219	240	DN80	150	180	180	14	DN125	130	119
8-40-5842-6	1648	850	1322	952	219	240	DN80	150	180	180	14	DN125	130	128
8-60-5842-8	2156	1358	1830	1460	219	240	DN80	150	180	180	14	DN125	130	155
10-32-5843-5	1528	608	1159	750	273	265	DN100	180	220	250	14	DN150	154	180
10-40-5843-6	1730	810	1361	952	273	265	DN100	180	220	250	14	DN150	154	193
10-60-5843-8	2238	1318	1869	1460	273	265	DN100	180	220	250	14	DN150	154	234
12-32-5844-5	1720	538	1249	736	323.9	320	DN125	220	260	300	18	DN200	204	272
12-40-5844-6	1920	740	1451	938	323.9	320	DN125	220	260	300	18	DN200	204	292
12-60-5844-8	2430	1248	1959	1446	323.9	320	DN125	220	260	300	18	DN200	204	348
15-40-5845-6	2080	740	1531	912	406.4	375	DN150	280	320	350	18	DN250	254	428
15-60-5845-8	2590	1248	2039	1420	406.4	375	DN150	280	320	350	18	DN250	254	513

Flange 'F' to BS EN 1092-1:2007 - PN6.

Flange 'K' to BS EN 1092-1:2007 - PN6.

# Installation and Operating Instructions

## Installation

The heat exchanger must be installed horizontally and levelled accurately, with the primary circuit (tubeside) through the tubes and the secondary circuit (shellside) over the tubes. The heat exchanger should only be connected in “counter flow” with the secondary circuit (shellside) connections always being positioned on top. (See schematic diagram below).

Alternative installations may also be acceptable; consultation with our technical department for acceptance should be made prior to installation.

It is very important that the secondary circuit is fully vented via the vent plug fitted in order to prevent any aeration taking place which can cause erosion of the tubes.

If ethylene glycol or any other heat transfer fluid is used in the secondary circuit, adequate mixing should be performed prior to filling of the heat exchanger.

If temperature control sensors are fitted to either the primary or secondary circuits of the heat exchanger, they should be fitted to the inlet circuit and not the outlet circuit in order to provide accurate temperature readings.

The pressure relief valve should not be removed or tampered with.

## Operation

Adequate provision should be made to ensure that in the event of the primary circuit being shutdown, the secondary circuit continues to operate for a period of time to enable the dispersal of residual heat to an acceptable level, preventing any damage to the heat exchanger.

Adequate provision should also be made to ensure that the secondary circuit pumps are in continual operation whenever the primary circuit is in operation.

Provision should also be made to ensure that any valves or ancillary equipment associated with either the primary or secondary side of the heat exchanger can not be accidentally turned off, thereby preventing flow through the heat exchanger.

## Exhaust Gas Heat Exchanger

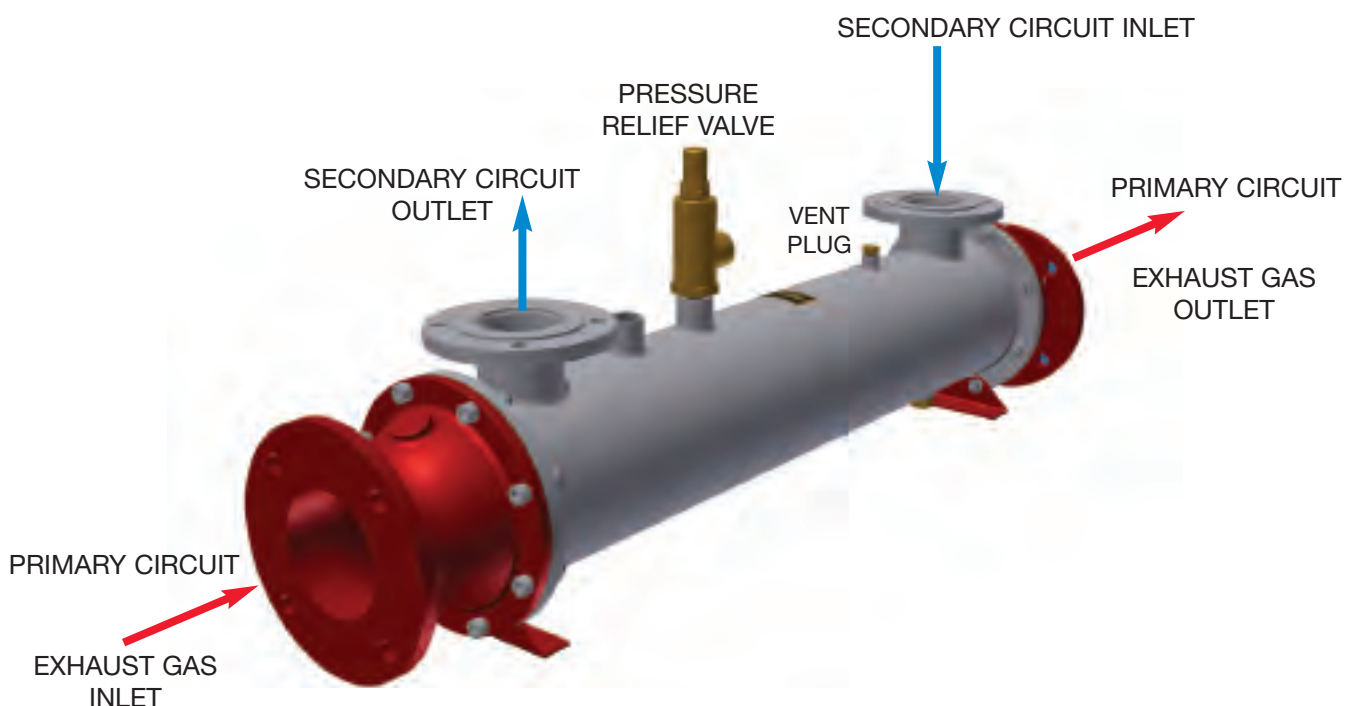



# Abgaswärmetauscher

Diese Wärmetauscher sind für die Wärmerückgewinnung von Abgasen von Erdgas-, Diesel- und Biobrennstoffmotoren und für deren Übertragung auf den Wasserkreislauf ausgelegt. Die extrahierte Wärme kann zur Raumheizung, zur Erwärmung von Brauchwarmwasser und für alle industrielle Prozesse, die warmes Wasser benötigen, verwendet werden.

- Standardsortiment zur schnellen Lieferung verfügbar.
- Geeignet für Motoren bis 1 MW.
- Geeignet für Verwendung mit Motoren, die mit konventionellen und alternativen Brennstoffen angetrieben werden.
- Voll geschweißte Edelstahlkonstruktion zwecks Zuverlässigkeit und Haltbarkeit.
- Dient ebenfalls zur Energiegewinnung aus Gas oder Luft und zur Übertragung auf den Wasserkreislauf.
- Kompakt und sehr leistungsfähiges Design zum leichten Einbau.
- Ideal zur Absenkung der Austrittstemperatur der Abgase in gefährlichen Umgebungen.
- In Verwendung zusammen mit Mantelwasser, Ladeluft, Brennstoff- und Ölkühlern, können Bowman Wärmetauscher bis zu 60% der Abwärme von einem Motor rückgewinnen.
- Eingebaute Bowman Wärmetauscher sorgen für kostenloses Heizen und Warmwasser.

Anhand der folgenden Informationen können unsere Wärmetechniker einen für Ihre Anforderungen spezifischen Wärmetauscher empfehlen:  
Brennstofftyp, Massenstrom des Abgases, Eintrittstemperatur des Abgases, Eintrittstemperatur und Durchflussmenge des Wasserkreislaufs.



**Automatisiertes Schweißen  
des Rohrendes und  
100% Kontrolle.**

## Installations- und Betriebsanleitung

### Installation

Der Wärmetauscher ist horizontal zu montieren und genau einzuebnen, wobei der Primärkreislauf (rohrseitig) durch die Rohre und der Sekundärkreislauf (mantelseitig) über die Rohre zu installieren ist. Der Wärmetauscher sollte nur im Gegenstrom angeschlossen werden, wobei die Anschlüsse des Sekundärkreislaufs (mantelseitig) stets auf der Oberseite positioniert sein sollten.

Alternative Installationen sind ebenfalls zulässig. Konsultieren Sie bitte unsere technische Abteilung vor der Installation.

Sehr wichtig ist, dass der Sekundärkreislauf durch den eingesetzten Entlüftungsstutzen völlig entlüftet ist, um Luftzufuhr zu verhindern, was zu einer Korrosion der Rohre führen kann.

Falls Äthylenglykol oder irgendeine andere Wärmeträgerflüssigkeit im Sekundärkreislauf verwendet wird, soll es bzw. sie vor dem Auffüllen des Wärmetauschers gut vermischt werden.

Falls Temperaturfühler entweder im Primär- oder Sekundärkreislauf des Wärmetauschers einzubauen sind, sollten sie nicht in den Auslasskreislauf sondern in den Einlasskreislauf eingebaut werden, damit genaue Temperaturmessungen durchgeführt werden können.

Das Überdruckventil sollte nicht entfernt oder verändert werden.

### Betrieb

Es sollten geeignete Vorkehrungen getroffen werden, um sicherzustellen, dass im Falle einer Abschaltung des Primärkreislaufs der Sekundärkreislauf für eine Zeit lang weiterhin funktioniert, um die Verteilung der Restwärme bei einem akzeptablen Füllstand zu ermöglichen und um jeglichen Schaden am Wärmetauscher zu verhindern.

Geeignete Vorkehrungen sollten ebenfalls getroffen werden, um sicherzustellen, dass die Pumpen im Sekundärkreislauf im kontinuierlichen Betrieb sind, immer wenn der Primärkreislauf im Betrieb ist.

Ferner sollten Maßnahmen ergriffen werden, um sicherzustellen, dass jegliche Ventile oder entweder zur primären oder sekundären Seite des Wärmetauschers zugehörige Zusatzausrüstung nicht versehentlich ausgeschaltet werden können bzw. kann, was somit den kontinuierlichen Durchfluss durch den Wärmetauscher verhindern würde.

## Scambiatori di calore per gas di scarico

Questi scambiatori di calore sono studiati per estrarre energia termica dai gas di scarico dei motori a metano, diesel e bio carburante e trasferirla al circuito ad acqua. Il calore estratto può essere utilizzato per il riscaldamento degli ambienti, dell'acqua calda residenziale e per qualsiasi processo industriale che richieda acqua calda.

- Gamma standard disponibile per spedizione immediata.
- Idonei per motori fino a 1 MW.
- Idonei per l'uso con motori alimentati da carburanti convenzionali e alternativi.
- Costruzione in acciaio inossidabile completamente saldata per una maggiore affidabilità e durata.
- Possono essere usati per estrarre energia da gas o aria e trasferirla a un circuito ad acqua.
- Design compatto e altamente efficiente per una facile installazione.
- Ideali per ridurre la temperatura in uscita dei gas di scarico in aree pericolose.
- Usati insieme a camicie d'acqua, intercooler, raffreddatori d'olio e carburante, le unità Bowman sono in grado di utilizzare fino al 60% del calore di scarico prodotto da un motore.
- Le unità Bowman forniscono RISCALDAMENTO e ACQUA CALDA GRATIS.



**Saldatura automatica dei terminali delle tubazioni e ispezione al 100%**

Date le seguenti informazioni, i nostri ingegneri termici possono consigliare l'unità più adatta per ogni specifica applicazione:  
Tipo di carburante, Portata del gas di scarico, temperatura del gas in entrata, temperatura e flusso in entrata al circuito dell'acqua.

## Istruzioni di installazione e funzionamento

### Installazione

Lo scambiatore di calore deve essere installato orizzontalmente e livellato con precisione, con il circuito principale (lato tubo) installato nei condotti e il circuito secondario (lato rivestimento) installato sulle tubazioni. Lo scambiatore di calore deve essere collegato solo in "controflusso" con le connessioni del circuito secondario (lato rivestimento) sempre in alto.

Possono essere idonee anche installazioni alternative; a questo proposito, richiedere l'approvazione del progetto al nostro reparto tecnico prima di effettuare l'installazione.

E' molto importante che il circuito secondario sia completamente sfiatato attraverso la bocchetta montata per evitare che un'eventuale aerazione possa corrodere le tubazioni.

Se nel circuito secondario viene utilizzato etilenglicole o altri fluidi per il trasferimento del calore è necessario preparare una miscela idonea prima di riempire lo scambiatore.

Se i sensori di controllo della temperatura sono montati sul circuito principale o secondario dello scambiatore di calore, dovranno essere montati nei circuiti interni e non su quelli esterni per permettere un'accurata lettura delle temperature.

La valvola di rilascio della pressione non deve essere rimossa o manomessa.

### Funzionamento

E' necessario adottare adeguate misure al fine di garantire che in caso di spegnimento del circuito principale, il circuito secondario continui a funzionare per un periodo sufficiente a disperdere il calore residuo fino a livelli accettabili, proteggendo in questo modo lo scambiatore da eventuali danni.

E' necessario inoltre far sì che le pompe del circuito secondario rimangano in continuo funzionamento quando il circuito principale è in funzione.

E' necessario accertarsi che le valvole o le attrezzature ausiliarie associate al lato principale o secondario dello scambiatore di calore non possano essere accidentalmente chiuse impedendo il regolare flusso attraverso lo scambiatore.

## Spalinowe wymienniki ciepła

Te wymienniki ciepła są zaprojektowane w taki sposób, że odprowadzają energię cieplną ze spalin wydanych przez silniki zasilane gazem ziemnym, biopaliwem bądź silniki Diesla i przekazują ją do obwodu wodnego. Wydobyte ciepło może być wykorzystane do ogrzewania pomieszczeń, grzania wody do użytku domowego, a także w dowolnych procesach przemysłowych, które wymagają użycia gorącej wody.

- Zapewnia się szybką dostawę standardowego asortymentu.
- Odpowiednie do silników do 1 MW.
- Nadają się do stosowania z silnikami napędzanymi paliwami konwencjonalnymi oraz alternatywnymi.
- Całkowicie szczelna konstrukcja ze stali nierdzewnej gwarantuje trwałość i niezawodność.
- Mogą być także wykorzystane do pozyskiwania energii z gazu lub powietrza i przenoszenia jej do obwodu wodnego.
- Zwarta i wysoko wydajna struktura ułatwia montaż.
- Idealnie nadają się do obniżania temperatury wyjściowej gazów w niebezpiecznych miejscach.
- Urządzenia Bowman używane w połączeniu z płaszczowym systemem schładzania wody, chłodnicą powietrza doładowującego, chłodnicą paliwa czy oleju, mogą odzyskać do 60% ciepła utraconego z silnika.
- Prawidłowo dostosowane urządzenia Bowman zapewniają **DARMOWE CIEPŁO I GORĄCĄ WODĘ.**

Biorąc pod uwagę poniższe dane, nasi specjaliści od systemów cieplnych mogą polecić Państwu urządzenie dostosowane do określonych potrzeb.

**Rodzaj paliwa**

**Wskaźnik masowego natężenia przepływu spalin**

**Temperatura spalin przy wlocie**

**Temperatura przy wlocie do obwodu wodnego oraz wskaźnik przepływu.**



**Automatyczne łączenie końcówki rury i całkowita kontrola**

## Montaż i instrukcja działania

### Montaż

Wymiennik ciepła musi być zainstalowany poziomo i dokładnie wyrównany, przy czym obwód pierwotny (rurowy) powinien być zamontowany przelotowo przez rury, a obwód wtórny (płaszczowy) – nad rurami. Wymiennik ciepła powinien być podłączony tylko z obwodem wtórnym w „przepływie przeciwnym”, a złącza zawsze należy umieszczać na górze. (Zob. schemat poniżej).

Możliwe jest także alternatywne podłączenie, jednak wcześniej należy skonsultować się w tej sprawie z działem technicznym w celu uzyskania zgody.

Bardzo ważne jest to, aby obieg wtórny był w pełni odpowietrzany poprzez dopasowane odpowietrzniki, dzięki czemu zapobiega się napowietrzaniu, które może być przyczyną korodowania rur.

Jeżeli w obiegu wtórnym ma być wykorzystany glikol etylenowy lub inny płyn przenoszący ciepło, przed napełnieniem wymiennika należy przygotować odpowiednią mieszankę.

Jeżeli do pierwotnego bądź wtórnego obwodu wymiennika ciepła przymocowane są czujniki kontroli temperatury, powinny być one zainstalowane przy wlocie do obiegu, a nie przy wylocie, aby dzięki temu zapewnić prawidłowy odczyt temperatury.

Nie należy usuwać zaworu bezpieczeństwa ani przy nim manipulować.

### Działanie

Należy podjąć odpowiednie kroki mające na celu zapewnienie działania obwodu wtórnego, w przypadku gdy obwód pierwotny przestanie pracować. Obwód wtórny powinien wtedy działać przez pewien czas, umożliwiając rozprzestrzenianie się ciepła użytkowego na zadowalającym poziomie i chroniąc wymiennik ciepła przed uszkodzeniem.

Należy również zapewnić, aby pompy obwodu wtórnego były w ciągłym działaniu, zawsze gdy działa obwód pierwotny.

Należy także podjąć właściwe kroki w celu zabezpieczenia wszelkich zaworów i dodatkowych urządzeń związanych z pierwotnym bądź wtórnym działaniem wymiennika ciepła, aby nie dopuścić do jego przypadkowego wyłączenia i wstrzymania przepływu.



## E. J. Bowman (Birmingham) Limited

Chester Street, Birmingham, B6 4AP, UK

Telephone: +44 (0) 121 359 5401 Facsimile: +44 (0) 121 359 7495

E-mail: [info@ejbowman.co.uk](mailto:info@ejbowman.co.uk) Web Address: [www.ejbowman.co.uk](http://www.ejbowman.co.uk)