

AD/A-002 625

GEODETIC SECOR SATELLITE

Robert H. Nichols

Army Engineer Topographic Laboratories
Fort Belvoir, Virginia

June 1974

DISTRIBUTED BY:

NTIS

National Technical Information Service
U. S. DEPARTMENT OF COMMERCE

ACCESSION for	
RTIS	<input checked="" type="checkbox"/>
DSC	<input type="checkbox"/>
UNCLASSIFIED	<input type="checkbox"/>
JUSTIFICATION	
BY	
DISTRIBUTION	ES
Dist.	ES
A	

Destroy this report when no longer needed.
Do not return it to the originator.

UNCLASSIFIED

SECURITY CLASSIFICATION OF THIS PAGE (When Data Entered)

REPORT DOCUMENTATION PAGE		READ INSTRUCTIONS BEFORE COMPLETING FORM
1. REPORT NUMBER ETL-TR-74-6	2. GOVT ACCESSION NO.	3. RECIPIENT'S CATALOG NUMBER ADIA-00 2625
4. TITLE (and Subtitle) GEODETIC SECOR SATELLITE		5. TYPE OF REPORT & PERIOD COVERED 1960-1970
		6. PERFORMING ORG. REPORT NUMBER
7. AUTHOR(s) Robert H. Nichols		8. CONTRACT OR GRANT NUMBER(s)
9. PERFORMING ORGANIZATION NAME AND ADDRESS USA ETL Liaison Office Fort Belvoir, Virginia 22060		10. PROGRAM ELEMENT, PROJECT, TASK AREA & WORK UNIT NUMBER 4A623501D853
11. CONTROLLING OFFICE NAME AND ADDRESS U.S. Army Engineer Topographic Laboratories Fort Belvoir, Virginia 22060		12. REPORT DATE June 1974
		13. NUMBER OF PAGES 37
14. MONITORING AGENCY NAME & ADDRESS (if different from Controlling Office)		15. SECURITY CLASS. (of this report) Unclassified
		15a. DECLASSIFICATION/DOWNGRADING SCHEDULE
16. DISTRIBUTION STATEMENT (of this Report) Approved for public release; distribution unlimited.		
17. DISTRIBUTION STATEMENT (of the abstract entered in Block 20, if different from Report)		
18. SUPPLEMENTARY NOTES		
19. KEY WORDS (Continue on reverse side if necessary and identify by block number) Global Mapping Satellite Geodesy SECOR System		
20. ABSTRACT (Continue on reverse side if necessary and identify by block number) The SECOR system is an all-weather, mobile, geodetic tool which was employed by the Army to collect more accurate data for determining relative locations of continents, islands, and other landmarks separated by large bodies of water or by inaccessible terrain. This information was needed to insure accurate targeting data for precise positioning of space tracking stations and for a general improvement of mapping.		

SUMMARY

SECOR is an acronym for the method by which the system operated; i.e., *Sequential Collation of Range*. The system was essentially an electronic distance measuring system which consisted of four ground stations ranging in sequence on a satellite-borne transponder. Geodetic positions were determined from the ranging data by trilateration. Three ground stations were located at known geodetic positions and the fourth station was set up on the point for which the coordinates were desired. These individual locations could be as much as 4800 kilometers apart, depending on the altitude of the satellite.

The slant range between each of the four stations and the transponder in the satellite was determined by phase-comparison techniques and was recorded on magnetic tape. Ranges from the three known stations were used to calculate the satellite's position in space throughout the pass. The satellite's orbital parameters were not required. The measured ranges from the fourth station and the calculated satellite positions were then used to calculate the coordinates of the fourth station relative to the three known stations. The accuracy of the position calculations was enhanced by the great amount of data redundancy provided by the system. For a typical satellite pass of 10 to 12 minute's duration, for example, the total number of ranges measured by the four ground stations was approximately 48,000. Because of geometry considerations, it was desirable to collect data during at least two satellite passes in order to determine the geodetic position of the unknown station. In practice, a large number of passes was used to afford the best geometry and added redundancy.

When the unknown station's geodetic coordinates were considered acceptable, one of the stations was moved to another unknown position. Thus, control was extended by a "leapfrog" method.

PREFACE

The author wishes to recognize the leadership provided by former Commanding Officers of USAETL, all of whom actively supported and participated in the SECOR Satellite Program: COL Ward H. Van Atta, COL Lloyd L. Rall, COL Hamilton W. Fish, COL Edward G. Anderson, and COL John R. Oswalt.

Recognition is also extended to LTC William W. Brown and COL E. G. Berry of the Office, Chief of Engineers, for their fine coordination efforts; and to the technical assistance provided by James A. Bizzell, Charles C. Johnson, and Claude W. Oliver.

The successful SECOR Program would not have been possible without excellent management provided by the following people: John T. Pennington, Gilbert G. Lorenz, Melvin C. Shetler, Charles R. Manor, Frederick M. Rohde, Edward C. Westerman, and Steve C. Nagy.

In July 1970, the SECOR Launch Team, under the direction of John G. Armistead, received the Army R&D Achievement Award: Launch Manager, Richard T. Malone; Launch Engineer, Robert H. Nichols; Launch Technicians, George W. Bunch and Walter E. Simpson; and Contract Administrator, Frederick M. Gloeckler.

CONTENTS

Section	Title	Page
	SUMMARYii
	PREFACE	iii
I	INTRODUCTION	1
	1. Subject	1
	2. Requirements	1
	3. Background	1
II	THEORY OF OPERATION	5
	4. System Operation	5
	5. Satellite Operation	6
III	SATELLITE DESIGN	7
	6. Type I	7
	7. Type II	8
IV	SATELLITE SUBSYSTEMS	9
	8. Transponders	9
	9. Telemetry	10
	10. Antennas	15
	11. Solar Cells	16
	12. Batteries	17
	13. Voltage Regulator	17
	14. Satellite Orientation	18
	15. Spin-Damping	18
V	SATELLITE ENVIRONMENTAL QUALIFICATIONS	18
	16. General	18
	17. Sinusoidal Vibration	19
	18. Random Vibration	19
	19. Acceleration	19
	20. Shock	19
	21. Thermal Vacuum	19
	22. Solar Simulation	19
VI	LAUNCH PHASE	19
	23. Test Equipment	19
	24. Pre-Launch	20
	25. Mate	22
	26. Launch	23
	27. Summary	24
	APPENDIX—SECOR Space Log	27

GEODETIC SECOR SATELLITE

I. INTRODUCTION

1. **Subject.** This report covers the development of the satellite portion of the Geodetic Sequential Collation of Range (SECOR) System. The purpose of the system was to provide geodetic coordinates of a ground point located from 160 to 4800 kilometers from known geodetic positions. The system consisted of four or more transportable ground stations which electronically determined distances to a satellite-borne transponder. Subject matter discussed herein will be primarily confined to the historical development of the satellite/transponder portion of the SECOR System.

2. **Requirements.** Of prime concern, under the SECOR satellite development, was to provide at least one satellite in orbit at all times to support the SECOR Operational Program. In order to achieve this, hardware development was required to coincide with launch schedules. To avoid the high cost of a launch vehicle, it was necessary to design the SECOR satellite so that it would be adaptable as a "secondary payload." As such, there were two primary constraints: there would be no impact on or control over the launch schedule, and an exact copy (dummy mass simulator) for launch would be provided in the event the intended satellite was not available. In order to preclude orbiting a mass simulator, a backup SECOR satellite was always provided at the launch site.

3. **Background.** The SECOR concept was originally conceived by the Cubic Corporation of San Diego, California, in 1954 and was developed that year into a system which provided missile trajectory information for the U. S. Armed Services. The U. S. Army Engineer Topographic Laboratories (USAETL), formerly the Geodesy, Intelligence, and Mapping Research and Development Agency (GIMRADA), purchased the satellites and transponders for the SECOR system from the Cubic Corporation.

The results of system tests conducted in the fall of 1961 raised questions as to the validity of the basic system concept, and the overall SECOR program was halted by the Office, Chief of Engineers (OCE) for re-evaluation. An evaluation team composed of engineers and scientists from GIMRADA, the U. S. Army Ballistic Research Laboratories, and the National Bureau of Standards made a thorough analysis of the system and concluded that the basic concepts were valid. Recommendations were made for modifications which would insure reliable operation of the hardware and provide desired system performance.

OCE then directed GIMRADA to proceed with the program and incorporate the equipment modifications in accordance with the evaluation team's recommendations.

Concurrent with ground equipment modifications, development of transponders and satellites using state-of-the-art techniques was initiated. The first SECOR transponder was similar to a TR-5, originally developed by the Cubic Corporation for the Air Force Missile Test Center at Patrick AFB, Florida. A ruggedized version (TR-7) was then developed for Eglin AFB, Florida, and a further improved version (TR-14) was developed for the White Sands Missile Range. The Cubic Corporation then conducted an investigation to arrive at a smaller, lighter, more reliable transponder, including more extensive use of transistors and other solid state devices.

In order to place SECOR transponders in the desired orbit, two methods were employed. Transponders were attached to large multipurpose satellites which contained several other space experiments, or the transponders were adapted to specially designed SECOR satellites. In the multipurpose satellites, such as GEOS (Geodetic Orbiting Satellite), the transponders shared power systems, antennas, and telemetry with other experiments. The SECOR satellites were self-contained and were of two basic designs: Type I is shown in Figure 1, and Type II, in Figure 2. The Type I was essentially a modified version of a Vanguard II satellite, spherical in shape and 20 inches in diameter. This model was eventually replaced by the Type II—basically a rectangular prism measuring 9 x 11 x 13 inches.

As evidenced by the SECOR Launch History (see Table 1), the earliest launches were somewhat unsuccessful primarily due to launch vehicle failure. However, sufficient tracking data were gathered from the ground stations to verify the system feasibility. Follow-on launches, beginning with EGRS I,* were more successful, and a number of SECOR satellites and transponders were placed in orbit to support the Corps of Engineers' mission of obtaining a worldwide network of geodetic control. These space-borne systems orbited at sufficient height to enable the ground stations to make highly accurate interisland and intercontinental ties. By moving ground stations from previously established geodetic control points to unknown points in a leapfrog fashion around the Earth's equator, an accurate world network was established.

*Engineer geodetic Research Satellite

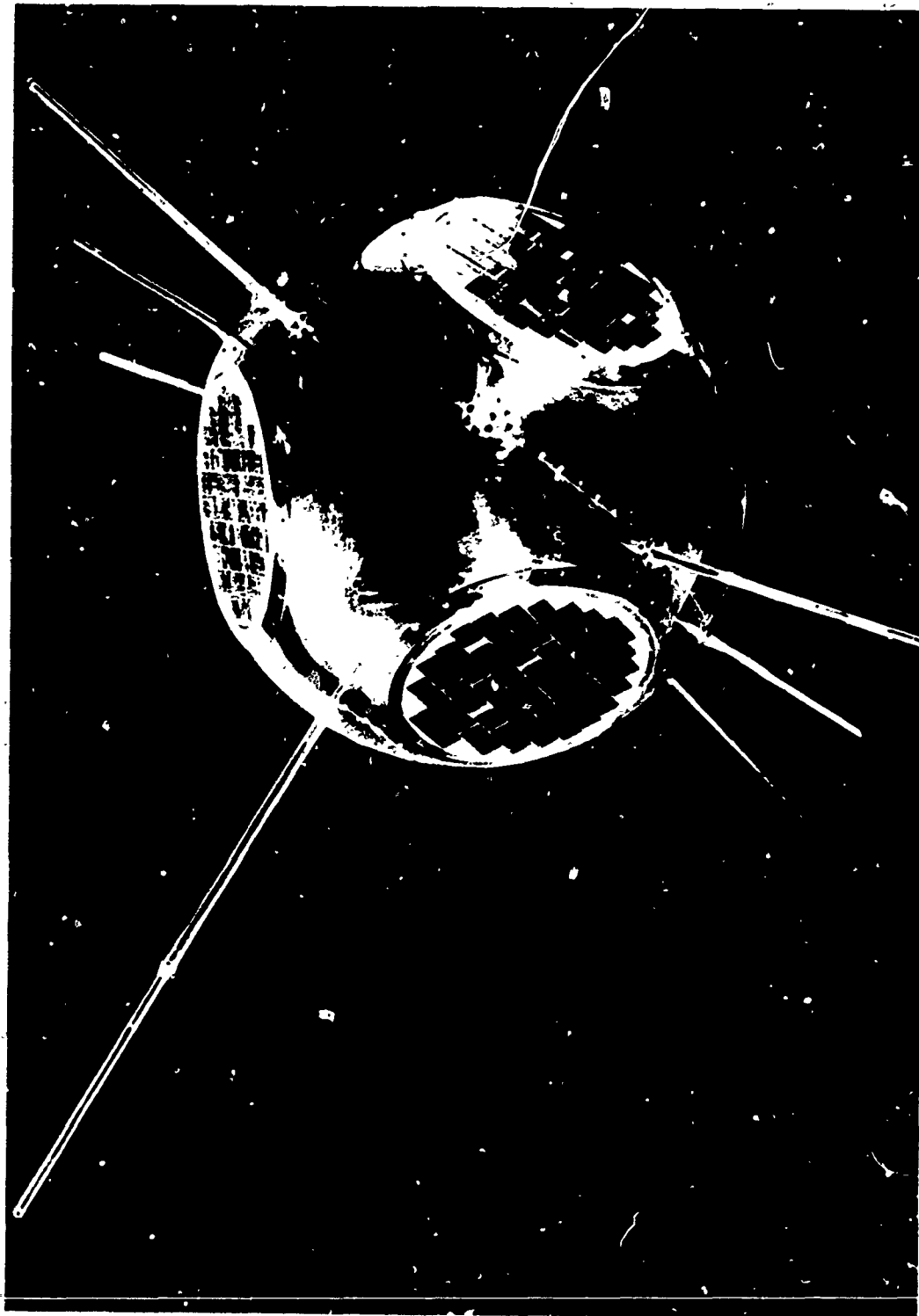

Figure 1. Type I SECOR satellite.

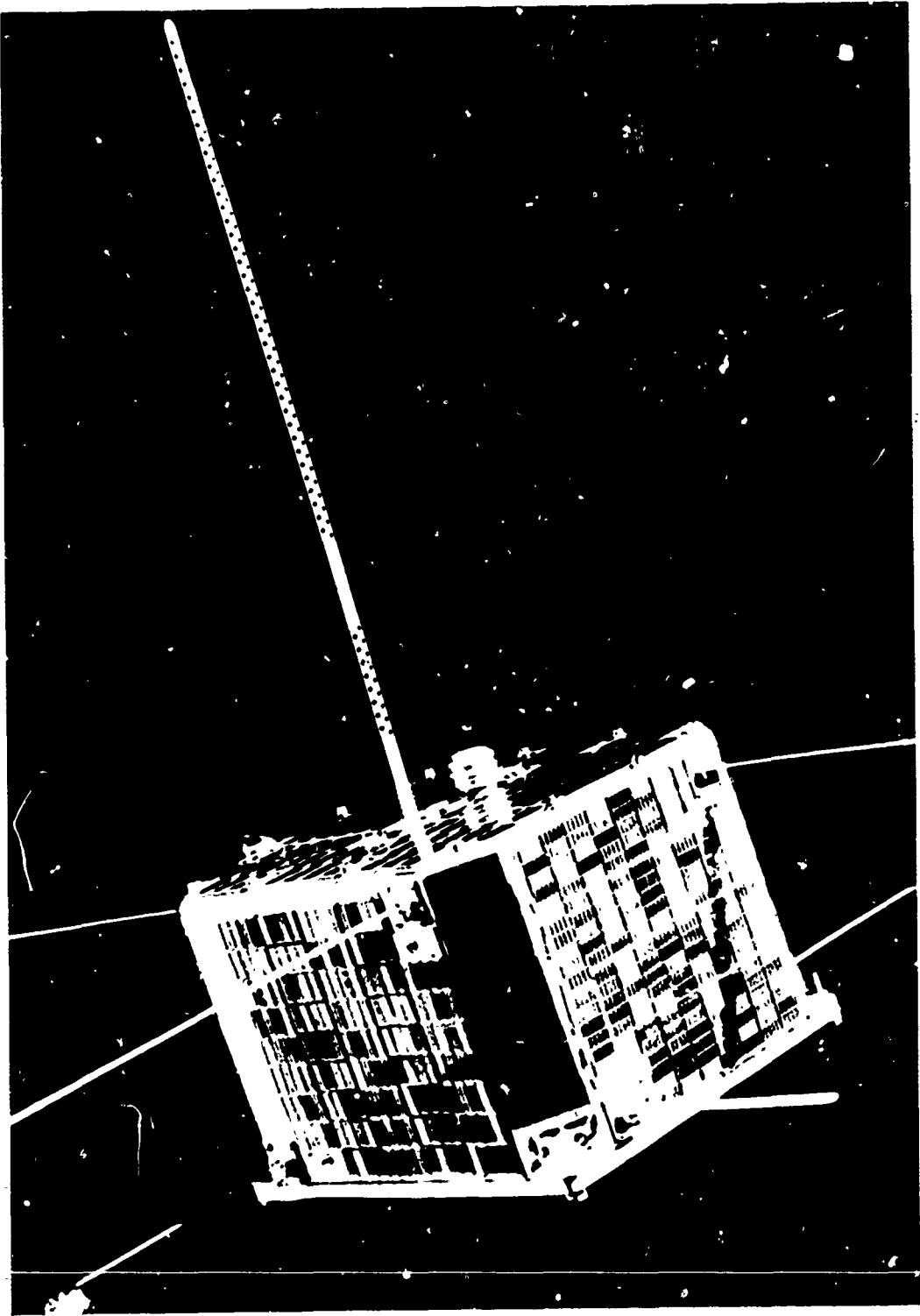

Figure 2. Type II SECOR satellite.

Table I. SECOR Launch History

Designation	Date	Satellite	Transponder	Remarks
TRANSIT III B	21 Feb 61	TRANSIT	TR-17	Launch Failure
DISCOVERER	20 Oct 61	DISCOVERER	TR-17	Partial Success
DISCOVERER	6 Nov 61	DISCOVERER	TR-17	Partial Success
DISCOVERER	12 Dec 61	DISCOVERER	TR-17	Partial Success
COMPOSITE I	24 Jan 62	TYPE I	TR-17	Launch Failure
ANNA IA	11 May 62	ANNA	TR-27	Launch Failure
ANNA IB	31 Oct 62	ANNA	TR-27	Partial Success
EGRS I	11 Jan 64	TYPE II	TR-27	Success
EGRS III	9 Mar 65	TYPE II	TR-27	Launch Failure
EGRS II	11 Mar 65	TYPE II	TR-27	Success
EGRS IV	3 Apr 65	TYPE II	C-101	Transponder Failure
EGRS V	10 Aug 65	TYPE I	TR-27	Partial Success
GEOS A	6 Nov 65	GEOS	TR-27	Success
EGRS VI	9 Jun 66	TYPE II	TR-30A	Launch Failure
EGRS VII	19 Aug 66	TYPE II	TR-30A	Partial Success
EGRS VIII	5 Oct 66	TYPE II	TR-30A	Transponder Failure
EGRS IX	29 Jun 67	TYPE II	TR-30A	Success
GEOS B	11 Jan 68	GEOS	TR-30A/S	Success
EGRS X	18 May 68	TYPE II	MAT	Launch Failure
EGRS XI	16 Aug 68	TYPE II	TR-30B	Launch Failure
EGRS XII	16 Aug 68	TYPE II	MAT	Launch Failure
EGRS XIII	14 Apr 69	TYPE II	TR-30B	Success
TOPO I	8 Apr 70	TYPE II	MAT	Success

II. THEORY OF OPERATION

4. **System Operation.** Three ground stations were located at known points on the surface of the Earth. Sequential range measurements to the orbiting SECOR satellite were conducted by each of the ground stations. A data-reduction computer established the exact orbital position of the satellite, as related to the ground stations, by locating a continuous mathematical intersection of the collective range measurements. A fourth ground station at an unknown point, also in sequence, conducted range measurements to the satellite. By a secondary calculation, the position of the unknown station was referenced to the three known station positions.

SECOR-system range measurements were based on the electronic determination of the phase shift of an electromagnetic wave during propagation to and from a satellite.

In order to meet the requirements of both accuracy and range, the SECOR system incorporated a multiple-frequency ranging technique. Ranging frequencies of overlapping values were chosen, eliminating points of ambiguity up to the maximum range of the system and providing precise measurements to this maximum range. Selected ranging frequencies are listed in Table 2. A further extension of range measurement was made possible with a pulse-transmission method and direct measurement of time delays.

5. **Satellite Operation.** The ground station transmitted a carrier at a frequency of 420.9375 MHz. Ranging, timing, and command subcarriers, all in the 500- to 600-kHz range, phase modulated the carrier to form a composite signal. Also within the subcarrier range were telemetry "ON" and "OFF" commands. The satellite transponder was normally in a standby condition (minimum receiver circuitry energized) until fully activated by the ground station's transmission of the "select call" subcarrier. Then, electronic switching circuits applied power to all transponder receiver and transmitter circuits. The "select call" frequency was within the 400- to 600-kHz range.

As stated previously, the satellite was normally interrogated by four ground stations during a pass. Each station interrogated the transponder in sequence, and the data burst (ranging subcarriers, etc.) from each station reached the satellite at different periods of time. The time allocated each station burst was 10 milliseconds, with 2.5 milliseconds spacing between bursts, for a total time frame of 50 milliseconds for all four stations. The ranging sequence was continuous for the time that the "select call" subcarrier was present at the transponder, and for 8 seconds thereafter.

Table 2. SECOR Range Measurements.

Combination (kHz)	Effective Ranging Frequency (kHz)	Total Wavelength (Meters)	Nonambiguous Range (Meters)	System Resolution (Meters)
585.533	585.333	512	256	0.25
585.533/548.937	36.596	8192	4096	16
585.533/583.246	2.287	131,072	65,536	256
549.233/548.937	0.286	0,048,576	524,288	2,048

The satellite/transponder demodulated the incoming composite signal and used the ranging and timing subcarriers to phase modulate two transponder-generated carriers of 449 and 224.5 MHz. These signals were received at the ground station and were demodulated. The resulting frequencies were combined to give the effective ranging frequencies as shown in the second column of Table 2.

Most of the early SECOR satellites utilized eight commutated telemetry channels, which provided general satellite "housekeeping" data. Two channels were used for calibration; three for temperatures; and one each for battery voltage, input signal strength, and transponder output power. This number was eventually increased to 16 channels for additional information. Telemetry was transmitted via a 136-MHz carrier, phase modulated by a subcarrier voltage controlled oscillator (VCO) which has a center frequency of 730 Hz.

In addition to the transponder and telemetry system, each SECOR satellite contained storage batteries, power-regulation system, antenna system, solar cells, despinner rods, and a magnetic orientation device.

III. SATELLITE DESIGN

6. **Type I.** The earliest SECOR satellites were of the Type I variety. As stated earlier, this satellite was of spherical construction, 20 inches in diameter. The satellite was compatible with several launch vehicles, including the Scout missile, as the primary payload. The Type I was designed to be as simple as possible and to take maximum advantage of proven satellite techniques and existing hardware.

This reflecting "ball" was designed for a 1-year lifetime and was capable of being photographed by Baker-Nunn cameras and the Smithsonian Astronomical Observatory. Its surface was of polished aluminum with a thin layer of silicon monoxide. The coating was used to help regulate internal temperatures. Six circular solar-cell plaques, about 8 inches in diameter, were spaced equidistant about the satellite's surface. Nine spring-loaded dipole antennas were also in evidence. About the equator were four antennas cut for 449 MHz and four cut for 224.5 MHz, alternately spaced, and connected as a turnstyle for circular polarization. A single 136-MHz telemetry antenna was attached at the apex of the satellite, 90° equidistant from the other antennas. A conical-shaped baseplate, placed on the satellite's base, was used for attaching the satellite to the ejection mechanism.

Inside the Type I was a cylindrical opening extending from the baseplate to the base of the telemetry antenna. This opening was used to house the voltage regulator and battery pack. Magnetic despinner rods were located throughout the inside

area of the satellite's skin. The transponder (Cubic-built TR-17s or TR-27s) and telemetry system were connected to a framework within the internal satellite structure.

The satellite's weight averaged 37 pounds, much of which was allocated to a power system designed to receive continuously and transmit 45 to 60 minutes within each 24-hour period.

7. **Type II.** The size of the Type II SECOR satellite was much more compact measuring 9.95 x 11.75 x 13.75 inches and weighing approximately 39 pounds. The satellite was almost covered with solar cells on all surfaces. The number of antennas was the same as for the Type I, but, rather than being "collapsible," they were made of flexible steel tape.

The prime reason for inception of the Type II was to provide a satellite which was extremely adaptable as a secondary payload. Launch vehicles that were funded by primary payloads frequently had additional space available for secondary payloads of low weight and suitable compactness. Since the Type II met these requirements, the Army avoided the high costs of launch vehicles.

The satellite also provided flexibility in accepting transponders of several different designs. Because the Type II's construction was compact and ruggedized, it was easier to handle.

Better provisions were made for external evaluation of the satellite's performance during acceptance and pre-launch test phases. Covers and panels did not have to be removed; therefore, monitoring the internal parameters of the system was more realistic.

The Type II satellite was constructed primarily of aluminum and was assembled around four structural subassemblies: baseplate assembly, center support assembly, solar panel support assembly, and wraparound assembly. The baseplate assembly provided mounting surfaces for the transponder and the center support and solar panel support assemblies. The center support assembly provided compartments for the storage of batteries as well as mounting surfaces for the telemetry and power system components. This assembly also supported the telemetry antenna. The solar panel support assembly provided surfaces to support the strings of solar cells. The wraparound assembly supported the solar panel assembly and the transponder ranging antennas.

The mounting plate for the Type I (used to mount the satellite to the launch vehicle) was simple, but it was not as positive and reliable as the technique used for the Type II satellite. The center of the Type II structure contained a cylindrical opening (thrust tube) 1 inch in diameter at the base and extending about 7 inches up the vertical axis of the satellite to a stop washer. This opening provided a housing for the ejection mechanism. Four small metal feet, precision machined and spaced, were placed at the corners of the satellite baseplate. These feet provided positive support for the satellite during launch.

A small "flight plug" extended 1 inch above the top of the Type II and was used as a shorting device to connect power from the internal power supply to the remaining satellite electronics.

IV. SATELLITE SUBSYSTEMS

8. **Transponders.** As indicated in paragraph 3, the SECOR satellites housed a variety of transponders in accordance with advancing state-of-the-art techniques. Nomenclatures, in ascending order, of SECOR transponders (indirectly and directly related) are as follows:

Transponders	Manufacturer
TR-5	Cubic
TR-7	Cubic
TR-14	Cubic
TR-17	Cubic
TR-27	Cubic
TR-28	Cubic
C-101	ITT
TR-29	Cubic
TR-30	Cubic
TR-30A	Cubic
TR-30A/S	Cubic
TR-30B	Cubic
MAT	ITT

The transponder consisted primarily of a receiver and a transmitter. Normally, in a standby condition, the dual-conversion receiver accepted the 420.9375-MHz carrier modulated with a "select call" tone from the ground station. The signal passed through an antenna and diplexer to an RF amplifier. From there it was fed into a mixer which was also receiving a signal from a standby local oscillator. The two signals were mixed and the resultant passed directly into an AGC-controlled IF amplifier.

The detected signal was applied to a data amplifier, then routed through a "select call" circuit to a switch, allowing power to be supplied to the remainder of the transponder circuitry. Two command functions were routed to the telemetry circuitry. Other modulation signals (four subcarrier frequencies for range measuring and a timing signal) from the ground station followed the same path to the data amplifier but were then routed to the transmitter section of the transponder. In this section, they were fed into a phase modulator and multiplier circuit, and from there to an exciter. The exciter doubled the incoming frequency, which yielded 224.5 MHz. This signal was routed through an antenna and used at the ground station as an offset frequency for ionospheric refraction correction (Figure 3).

The 224.5-MHz signal was also doubled to 449 MHz and routed into a diplexer and associated antenna network. A small portion of the transmitted output was tapped off and used as local-oscillator injection for the transponder's receiver. This caused the transponder to operate as a negative-feedback amplifier for the modulation signals. The feedback effect stabilized the phase relationship between the received and retransmitted modulation signals.

A phase lock loop was used to provide correlation detection, allowing automatic acquisition and phase tracking at signal levels of -120 dBm or lower, depending on the modulation index used. Also, the phase-lock feature allowed easy adaptation of the transponder to coherent carrier systems.

These phase-lock transponders (Figure 4) possessed improvements, such as greatly increased receiver sensitivity which allowed for lower power output from the ground station and reduced ground station weight. Consequently, ground station peripheral equipment, such as generators and air conditioners, were greatly reduced in size and weight.

The earliest transponder had a 1-watt power output. Later transistorized versions were capable of 4 watts with modulation indices of 0.7 and 2.4. Block diagrams of two typical transponders are illustrated in Figures 5 and 6.

9. **Telemetry.** The telemetry subsystem was used to monitor the operation of the satellite/transponder systems and the thermal environment under which they operated. Command tones, to turn the telemetry on or off, were generated from the ground station to the SECOR satellite. These commands (TIM ON and TM OFF) modulated the 420.9375-MHz carrier which was used to interrogate the transponder. The receiver portion of the transponder detected all modulation tones and routed them through a data amplifier to the necessary circuits—in this case, the telemetry command boards. To avoid the necessity of sending a continuous command, the telemetry

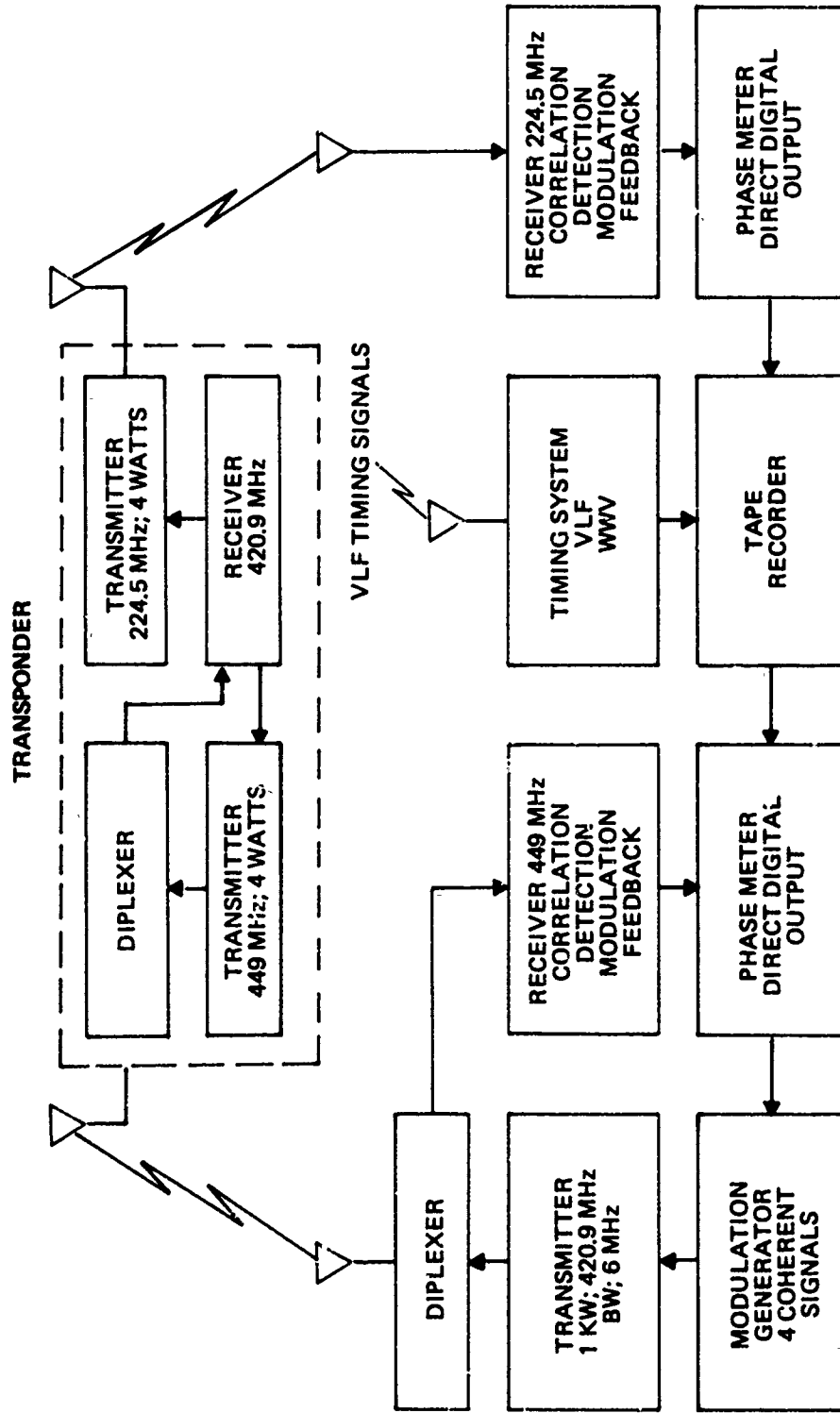

Figure 3. Transponder operation.

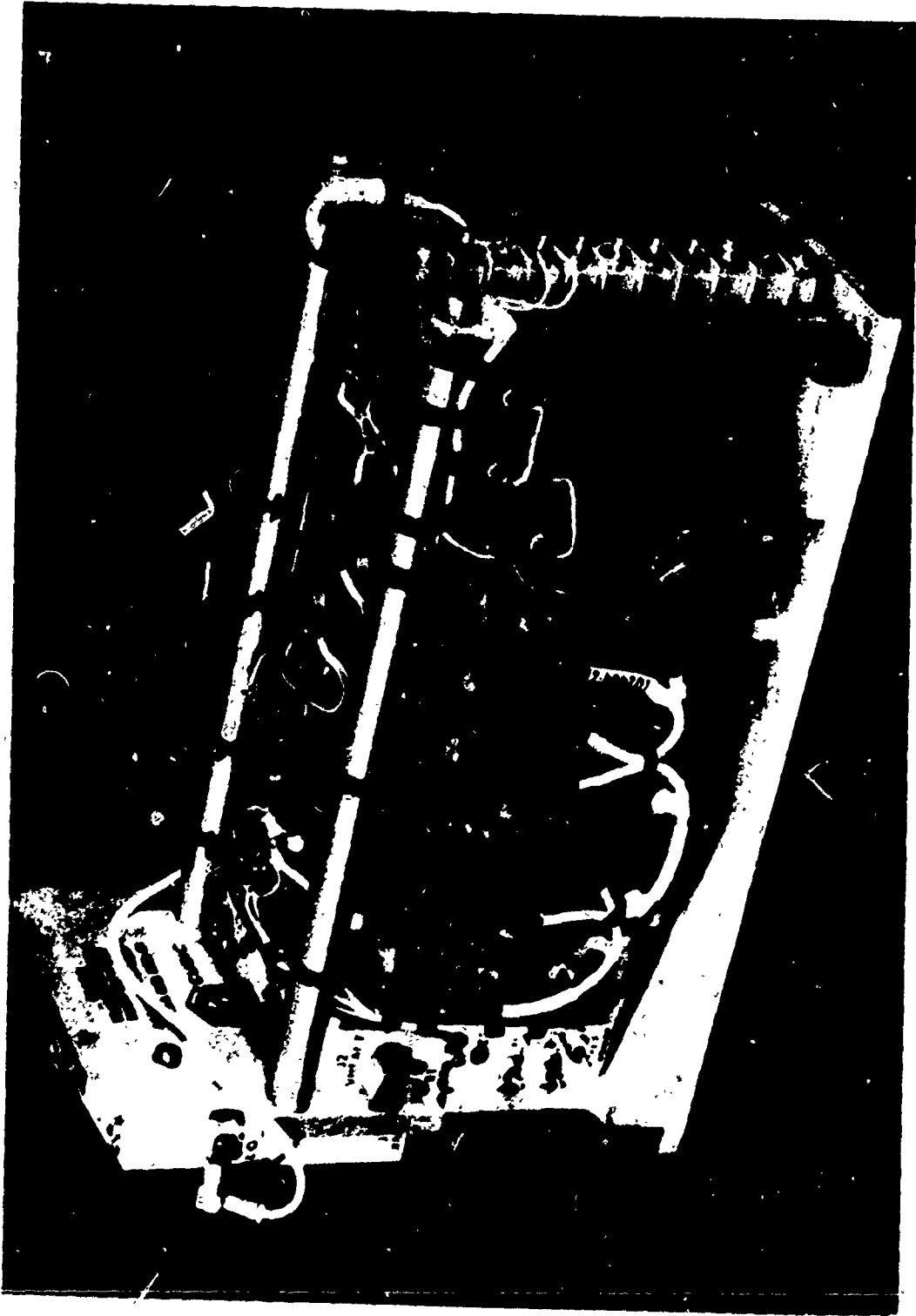

Figure 4. SECOR transponder TR-30A.

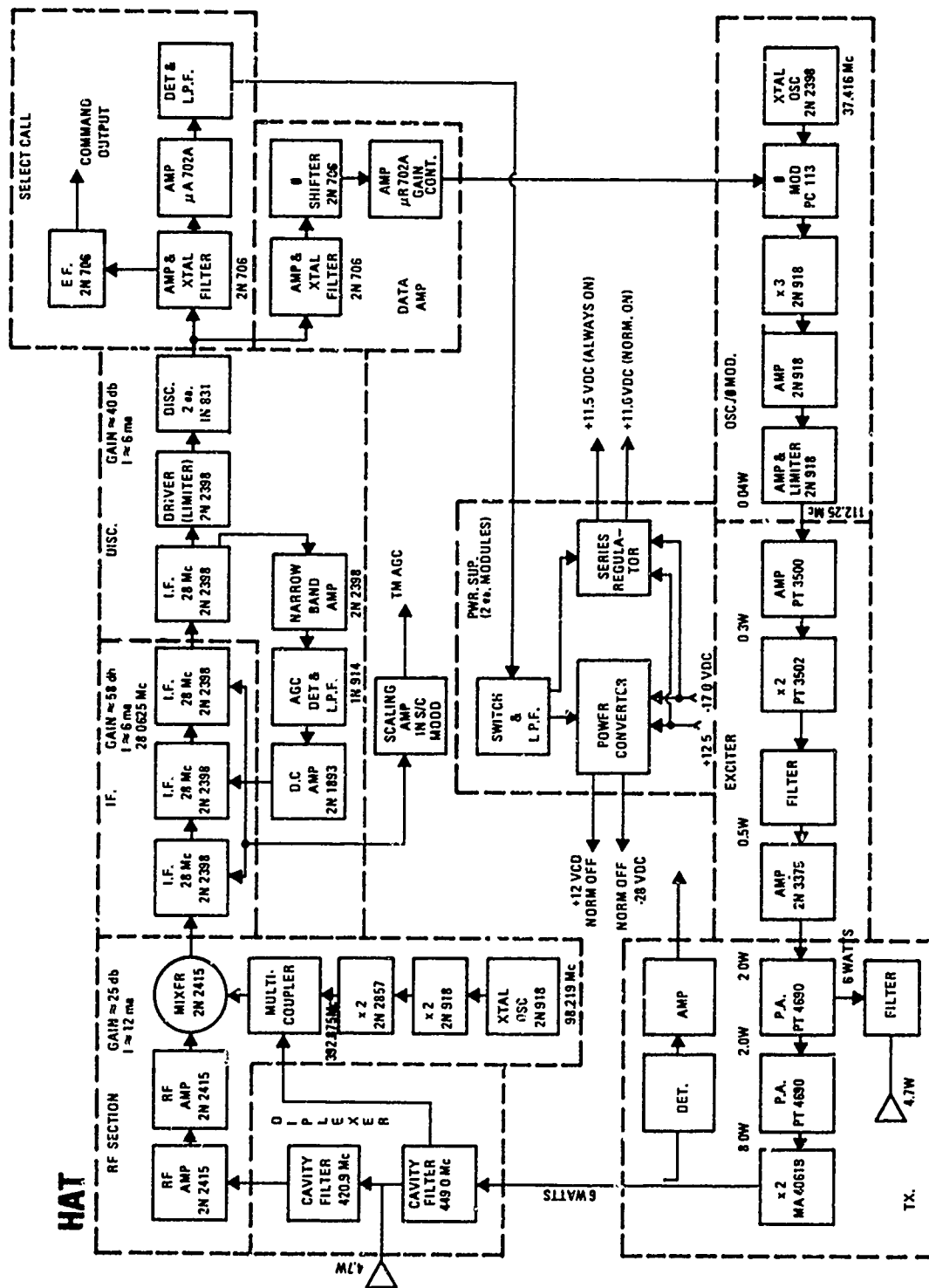

Figure 5. High-altitude transponder (HAT).

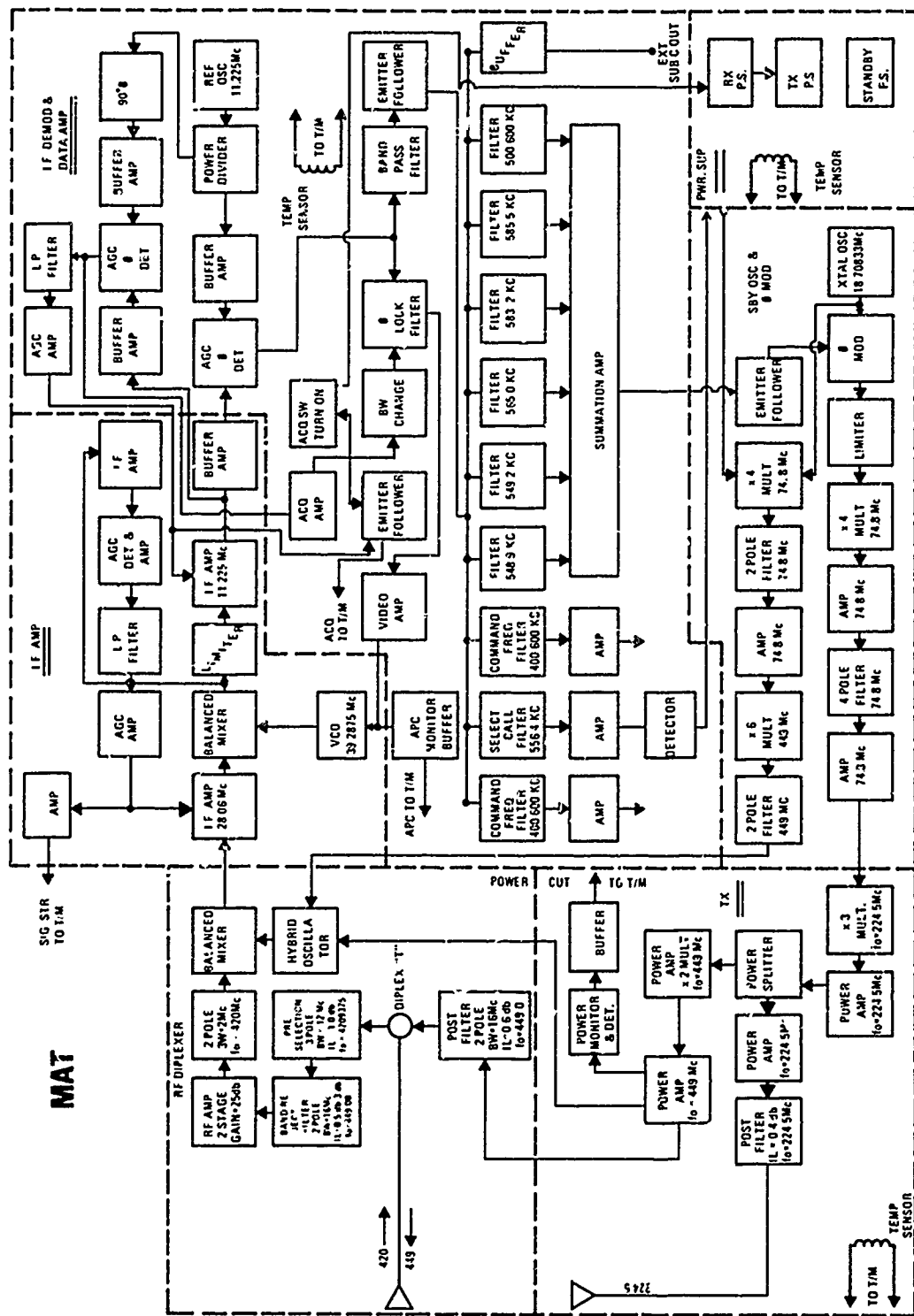

Figure 6. Multi-altitude transponder (MAT).

system utilized a latching relay which maintained itself in the position to which it had been driven. Therefore, once the telemetry was turned on, it would remain on until a TM OFF signal was received and vice versa.

The original telemetry system was a miniature solid state device, consisting of eight sensing elements which utilized FM-FM-type modulation. The subsystem was made up of five boards: sensor module, timer, 8-channel commutator, subcarrier oscillator operating on IRIG band No. 3, and a transmitter operating at 136.8 MHz with an output of 100 milliwatts. Measurements were transmitted at intervals of 1 ± 0.2 seconds, providing a telemetry frame of 8 ± 1.6 seconds and having a modulation index of 1 radian.

The most recent SECOR satellites were equipped with 16 telemetry channels. Further "housekeeping" information was required of transponders with improved capabilities. The added channels also improved the capability to diagnose problem areas and make more accurate predictions of satellite operational lifetime based on electrical performance characteristics.

Commutator sample-rate was decreased to intervals of 1 sample per 0.75 ± 0.2 seconds, thereby increasing a telemetry frame to an interval of 12 ± 3.2 seconds. The original sensing elements and the modified version are further defined in Tables 3 and 4.

10. **Antennas.** The Type I SECOR satellites used antennas resembling aluminum rods approximately 1/2-inch in diameter and cut to match frequencies of 224,449, and 136 MHz. The nine antennas (four at 224 MHz, four at 449 MHz, and one telemetry antenna) were simple dipoles, having no gain and producing regularly shaped "doughnut" patterns. They were spring loaded and collapsed about the satellite, erecting automatically upon spacecraft separation from the launch vehicle.

Table 3. Original 8-Channel Telemetry

Channel	Function	Channel	Function
1	Low Calibration	5	Power Output (449 MHz)
2	High Calibration	6	Temperature (Data Amplifier)
3	Battery Voltage	7	Temperature (Battery Assembly)
4	AGC Voltage	8	Temperature (Satellite Shell)

Table 4. Advanced 16-Channel Telemetry

Channel	Function	Channel	Function
1	Low Calibration	9	Battery Voltage
2	Mid Calibration	10	Temperature (Battery)
3	High Calibration	11	Temperature (Satellite Shell)
4	APC (Automatic Phase Control)	12	Temperature (Data Filter)
5	Acquisition	13	Temperature (Power Supply)
6	AGC Voltage	14	Temperature (Transmitter)
7	Select Call	15	Charge Current
8	Power Output (449 MHz)	16	Battery Voltage

The Type II satellites were identical in electrical characteristics but were radically different in physical construction. Elements of the antennas were fabricated of hardened, tempered steel strips, 0.5-inch-wide by 0.009-inch-thick, and formed to a 0.75-inch radius. Each antenna was plated with silver to improve conductivity. Numerous 1/8-inch-diameter, circular perforations were made throughout the antennas' length in order to minimize the effect of shadows cast on the solar cell panels. The antennas were designed to be bent and tucked beneath the satellite while it was held in place by pressure against a rubber pad which was a part of the satellite/launch vehicle interface. Each antenna was also coated with Teflon, which served to protect the solar cells from possible scratches when the antenna was in the folded position.

The smallest antennas served as the transmitting antennas for 449 MHz and as the receiving antennas for 420.9375 MHz. A diplexer, which was an integral part of the transponder, allowed for this dual function through a single antenna connection.

11. **Solar Cells.** Type I SECOR satellites were provided with P/N-type solar cells mounted on honeycomb aluminum plaques which were in turn mounted on the satellite. Six plaques, each containing 160 solar cells, were mounted symmetrically around the satellite—three each in the upper and lower hemispheres. Isolation diodes were used to isolate each panel from the battery and the load. A regulator was provided to reduce the variation in voltage from the battery/solar-cell combination.

The Type II satellite had 10 solar-cell panels supplying charge current to the batteries. Solar panels were installed on the top and bottom surfaces and on

the four sides and corner surfaces of the wraparound assembly. The 10 panels were comprised of a total of 1456 N-on-P solar cells. The selection of shallow-diffused, N-on-P-doped, silicon material was made because its characteristics are such that it is less susceptible to radiation effects from the Sun during orbit. Also, in order to assure long orbital life (more than 1 year), each cell was protected by a quartz cover with a thickness of 60 mils.

Each cell produced approximately 405 millivolts at 60 milliamperes. Cells were in series-parallel, arranged to provide 17 volts at each panel. Cells were individually measured and selected by placing them in a solar simulator having the same intensity and spectral distribution as sunlight in space. The use of a simulator insured that no mismatching and consequent power loss occurred when the panels were subjected to a space-sunlight environment.

12. Batteries. The main requirement of batteries for Type I satellites was that they have very low leakage over a 1-year lifetime. Hermetically sealed, nickel cadmium batteries, with specially designed nylon contact spacers, were selected. Each cell was matched to within 0.03 volt along the complete discharge characteristic down to 1.14 volts. The cells were packaged in two parallel strings of 11 series cells each. The package was sealed in a potting compound and shaped to match the allocated battery compartment.

Batteries for Type II satellites were similar electrically, although packaged differently. The seals were considerably improved, since a triple seal design which was superior to, and consistently outperformed, the older "pin seal" design, had evolved. The cell had the same capacity as the older design but differed in the positive terminal configuration, which was of glass-ceramic-glass design. Cells were used in sets, with characteristics matched to a 6.0-Ah capacity within 40 millivolts. Typically, a battery pack was charged at 600 milliamperes for 14 hours; nominal output was 13.75 volts.

More extensive use of insulation between cells was also employed for greater assurance against electrical shorts. Finally, potting compounds with improved thermal-conduction characteristics were utilized to prevent premature aging of the cells.

13. Voltage Regulator. Large voltage variations caused serious variations in transponder operations, leading to decreased reliability. Therefore, the use of a series-type voltage regulator was necessary. The regulator accepted input voltages from 12. to 17.5 volts, provided 12 ± 0.25 volts, and could handle load variations from 0.03 to 2.8 amperes. The regulator was small, relatively simple, and had low power loss.

14. **Satellite Orientation.** The satellite was designed to maintain a constant relationship between the antenna radiation patterns and the surface of the Earth. A permanent magnet was mounted along the same axis as the telemetry antenna to keep the axis directed toward the Earth's north magnetic pole. Damping rods were installed to reduce oscillatory motions of the spacecraft.

The magnetic stabilization system used in the Type I satellite consisted of a bar magnet, 3.0 inches long by 0.5 inch diameter, and two 185-degree-arc damping rods of 0.065-inch diameter. Each magnet was tested, based on a requirement that they have a magnetic moment of greater than 6000 unit-pole/cm.

A slightly larger magnet was employed by the Type II satellite; this magnet measured 3.5 inches by 0.5 inches. It was mounted in a fashion similar to that in the Type I both resulting in the same satellite orientation. Further considerations were made for oscillations, however, when higher orbital ranges (500-2500 nautical miles) became a program requirement.

15. **Spin-Damping.** Aside from oscillations which occurred when the satellites passed the Earth's magnetic poles, a certain amount of spin was imparted on the satellite when ejected from the launch vehicle. If the spin were of a high rate, the SECOR transponder would have had limited usefulness. If the rate were less than 1 rpm, normal functions were restored. The satellites were equipped with the maximum number of shorted-coil, magnetic despin rods consistent with good spacing. Magnetic spin-damping was predicted to be inefficient at 2500-nautical-mile orbits due to the Earth's weak magnetic field at that altitude. It was, therefore, critical to minimize spin at launch by locating the satellite's center of gravity to coincide with the orbit injection thrust.

A maximum of 50 rods was used in the Type II satellite. More rods would have resulted in a spacing too close for efficient damping.

The wirewound, shorted-coil method was employed. Rods in lengths to 12 inches were fabricated from 0.06275-inch-diameter steel wire. Coils of copper wire were wound around each end of a rod; the two ends then were joined and soldered together. The mechanism was designed to despin the satellite at a rate greater than 1 rpm per 5 days.

V. SATELLITE ENVIRONMENTAL QUALIFICATIONS.

16. **General.** A comprehensive environmental test program was established for each transponder and satellite. Prototype units accordingly received more difficult

levels of acceptance than those actually intended to be launched (flight models). Maximum levels for environmental qualifications were based on calculations derived from launch vehicle parameters and conditions in "space."

Satellites were required to operate satisfactorily under all conditions during subjection to electrical tests simulating actual operational missions. Type I and Type II satellites were subjected to similar tests, but the level of testing was dependent on the intended launch vehicle. Because of the wide variances, environmental tests described herein are very generalized.

17. **Sinusoidal Vibration.** The frequency of vibration varied at a constant logarithmic sweep rate from 5 to 3000 Hz and from 0.5 inch double amplitude to ± 20 g over a 15-minute period; this was repeated in each of three major axes.

18. **Random Vibration.** The frequency of vibration varied from 15 to 200 Hz at $0.7 \text{ g}^2/\text{Hz}$ and 400 to 2000 Hz at $0.139 \text{ g}^2/\text{Hz}$ over a 2-minute period; this was also carried out in each of three major axes.

19. **Acceleration.** This test consisted of a sustained level of radial acceleration of 15 g along the thrust axis for a 10-minute period and a level of 5 g along the transverse axis for an equal period of time.

20. **Shock.** Three shocks of 200 g for 0.75 millisecond were administered six times along each of three major axes.

21. **Thermal Vacuum.** Each satellite was placed in a chamber which was then evacuated to at least 1×10^{-5} millimeter Hg. After proper "soaking" at low and high extremes of -5°C to $+40^\circ\text{C}$, respectively, each satellite was tested for reliable operation over the temperature between these two values.

22. **Solar Simulation.** Several satellites were selected to go through a full solar simulation test at $450 \pm 50 \text{ Btu/hr-ft}^2$, uniformly distributed over the plane of the spacecraft within ± 10 percent of the average intensity. Spectral distribution corresponds to solar energy within ± 10 percent from 0.3 to 2.5 micrometers.

VI. LAUNCH PHASE

23. **Test Equipment.** The test equipment, required to properly evaluate the performance of the transponder/satellite, was made up of standard commercial test instruments and a specially developed Transponder Calibration Unit (TCU). For pre-

launch checkout purposes, the instruments were tailored to fit into two large equipment racks. A complete list of the SECOR pre-launch test equipment appears below:

- a. Chart Recorder
- b. Sun Gun
- c. Frequency Counter
- d. UHF Signal Generator
- e. VHF Signal Generator
- f. Pulse Generator
- g. Power Meter
- h. Spectrum Analyzer
- i. RF Voltmeter
- j. Oscilloscope
- k. Directional Coupler
- l. Attenuation Pads
- m. Multimeter
- n. Power Supply
- o. Telemetry Receiver
- p. Bolometer
- q. Stopwatch
- r. Test Antenna

A method for indirect determination of calibration numbers was provided by the TCU. This device was essentially a portable DME station-simulator, which could be internally calibrated and then used to measure phase delay in a transponder via a wire link. The TCU could also be used to give repetitive-type phase-delay numbers via an air link. The device allowed transponder phase-delay characteristics to be determined without actually transporting each transponder to a SECOR ground station.

24. **Pre-Launch.** The SECOR satellite, utilizing phase-comparison techniques, approached state-of-the-art in measurement capability; consequently, extreme care was exercised in component alignment and checkout. Since the transponder was not available for alignment and checkout after launch, every precaution was taken to assure proper transponder operation prior to launch. The SECOR System required utmost phase stability for electronic ranging. Because satellites were required to operate for extended periods of time in orbit, every effort was made to assure a reliable, stable transponder/satellite by careful design, high quality fabrication, and thorough test and evaluation program.

The pre-launch procedures were developed, refined, and proven by the GIMRADA Launch Team. Because of the large number of variables involved in placing

a payload in orbit, precise guidelines were difficult to establish. Experienced personnel were required to remain "on site" to make pre-launch procedural changes which were frequently necessary. Aside from payload preparation, a great amount of time was needed for coordination efforts with other agencies and services. The SECOR Launch Team was comprised of a Launch Manager, a Launch Engineer, an Electronic Technician, and a Contractor Engineer. Additional technical support was provided as required. A typical pre-launch activity demanded the Launch Team, test equipment, and perhaps two flight-qualified SECOR satellites to arrive 4 weeks prior to the scheduled launch. Each satellite was required to pass three complete electrical tests. The first was performed immediately after arrival to check for damage during shipment. The object of the second test was to detect minor electrical changes in values on a comparison basis. Slight changes might signal a forthcoming problem area. The third test was the final test prior to mating the satellite to the booster. The results of this test were used to select which satellite had the highest probability of success. In the event the satellite was accessible after mate, a fourth test was conducted via air link. A typical launch site test sequence was as follows:

- a. First Electrical Test
- b. Battery Charge/Discharge Test
- c. Fit Test
- d. Solar-Cell Test
- e. Second Electrical Test
- f. Telemetry Compatibility Test
- g. Telemetry Calibration Test
- h. Third Electrical Test
- i. Clean Solar Cells
- j. Final Battery Charge
- k. Mate
- l. Fourth Electrical Test

Most pre-launch testing was conducted in special facilities such as "clean rooms" and anechoic chambers. All pre-launch tests were formulated to check the following parameters and requirements:

- a. Frequency Accuracy and Stability
- b. Phase-Lock Range Requirements
- c. RF Power Output Requirements
- d. Select Call Sensitivity Requirements
- e. Data Transient Requirements
- f. Transponder Warmup/Shutdown Requirements
- g. Modulation Requirements
- h. Dynamic Range Requirements

- i. Phase Stability
- j. Internal Telemetry Requirements
- k. Phase Detector Output Requirements
- l. Primary Power Requirements
- m. AM Suppression Requirements
- n. Data Feedback Loop Gain
- o. Data Feedback Loop Phase
- p. Pulsed Carrier Requirements
- q. Ranging Sensitivity Threshold
- r. VSWR

Aside from meeting SECOR requirements, it was also necessary to insure that the satellites caused no adverse effect on the launch vehicle or other satellite systems on board. Pre-launch tests were especially complicated on joint efforts such as GEOS. The GEOS spacecraft was comprised of numerous experiments and subsystems, including the SECOR transponders, all affixed to one satellite. This required sharing of power systems, antennas, etc. Further information regarding this type of spacecraft is discussed in paragraph 26.

25. **Mate.** After pre-launch tests were completed, the SECOR satellites were evaluated; one was selected as a primary payload and the other as a backup. The Type II, for example, underwent the following checks during actual mate:

- a. Proper operation of ejection switches.
- b. Proper operation of booster's ejection monitor switch.
- c. Mounting nut properly torqued.
- d. Removal of antenna tie-down line.
- e. Installation of "flight plug."
- f. Epoxy all external plugs and connectors.

In preparation for mate, the satellite antennas were folded beneath the satellite and held in place by 20-pound-test, monofilament fishing line. A handling fixture was then attached to the satellite, which was transported to the booster stage of the launch vehicle. The satellite was positioned over its mounting tray and ejection spring. The satellite was then pressed down firmly into four "foot retainers" on the tray, and a retaining nut (torqued to approximately 65 in.-lb) held the satellite in place. Careful observation was then performed to assure that the two satellite ejection switches were properly placed and functioning. The redundant switches were wired in parallel at the satellite's baseplate and were used to disconnect the internal power system from related satellite electronics. Therefore, there was no unnecessary drain on

the fully charged satellite batteries while waiting for the actual liftoff to take place. Since the satellite's telemetry system was left in a "TM-ON" condition, closing either of the spring-loaded ejection switches actuated the SECOR telemetry and transponder standby circuitry; this occurred when the satellite was ejected into orbit.

After verification that the satellite was properly attached to its mounting tray, the handling fixture was removed. The monofilament was cut from the antennas and removed. A rubber pad on the mounting tray held the antennas tightly in place until ejection.

The final step was to install the "flight plug." If necessary, further last minute solar-cell cleaning was possible. To minimize vibration effects imparted by the rocket during the launch phase, external plugs and connectors were spotted with an epoxy compound. The Launch Team or its representative normally remained available until liftoff.

26. **Launch.** The actual launch was the culmination of the many months of planning and preparation. It was the result of long, rigorous hours of testing and retesting, reliability studies, predictions and calculations, schedules and slippages; and complex coordination efforts with interagencies, numerous contractors, NASA, Departments of the Army, Navy, and Air Force, and the Department of Defense.

As noted earlier, some launches such as ANNA (Army/Navy/Air Force) and GEOS were multipurpose satellites utilizing, among other items, the transponder portion of the SECOR satellite. These multipurpose satellites were built by Johns Hopkins University/Applied Physics Laboratory (JHU/APL) and were designed for geodetic missions under the National Geodetic Satellite Program. Its objective was to determine more precisely the location of the major land masses relative to each other and to the Earth's center of mass; also, to determine the detailed structure of the Earth's gravitational potential to an accuracy of one part in 10^7 . Aside from the SECOR ranging transponder, the spacecraft also housed such systems as doppler, range-rate transponder, C-band radar, optical beacon, and laser reflectors. As far as SECOR was concerned, ANNA proved to be less than successful; however, GEOS provided exceptional results.

EGRS XI and XII were launched together with hopes of obtaining direct comparison results from a TR-30B and a MAT. Unfortunately, the launch vehicle's heat shield failed to separate and the mission was lost.

In one case, EGRS V, a SECOR Type I, was the only payload. The NASA Scout rocket, with an experimental fourth stage, imparted a higher-than-normal spin rate on the satellite. That, along with insufficient despinn rods (corrected in later satellites), resulted in limited success.

In most cases, however, the SECOR satellite was launched via "piggyback." The term refers to more than one experiment being launched from the same vehicle. This was primarily a matter of economics, since 2 or even 10 payloads might share launch costs.

Desirable orbits for SECOR satellites ranged from 500 to 2500 nautical miles in circular, polar orbits. Low orbits were adequate for shorter range measurements, but when it came to connecting continents (i.e., long legs of a triangle) the higher orbits were required. Polar orbits characteristically provided good Earth coverage by the satellites and provided a maximum amount of sunlight on the solar cells, thereby maintaining almost continuous battery charge. A partial list of satellites, which illustrates launch parameters desired and/or achieved, is given in Table 5.

In order to place satellites in the proper orbit, exhaustive studies were necessary to determine the proper vehicles, stages, and boosters. Numerous methods were investigated and used to reach the objective. For example, EGRS IX was launched from a Thor rocket and a Burner II stage (built by The Boeing Co.). In order to achieve a 2100-nautical-mile orbit carrying both a SECOR Type II and an Aurora satellite, a new injection stage, or "payload dispenser," was designed, built, and tested by Boeing. The stage was mounted atop the Burner II. Figure 7 illustrates the launch sequence as exemplified by the EGRS IX launch.

27. **Summary.** The Engineer Topographic Laboratories (ETL) embarked on a mission to support the SECOR Operational Program when satellites and transponders were somewhat crude. While supporting the Army Map Service operations, ETL also conducted an extensive research and development program to improve spacecraft design characteristics. The result was a highly advanced SECOR spacecraft, which not only allowed for a completely miniaturized ground station but also provided for far greater system accuracy and reliability. Original SECOR specifications called for a position accuracy of 30 meters; by the end of the program, 3- to 10-meter positioning was commonplace.

Table 5. Satellite Launch Parameters

Name	Inclination Angle (Degrees)	(Period) (Minutes)	Apogee (Kilometers)	Perigee (Kilometers)	Launcher
EGRS I	69.91	103.4	928	916	TAT/Agena
EGRS II	89.98	97.5	992	982	Thor/Able Star
EGRS III	70.09	103.5	942	906	Thor/Agena
EGRS IV	90.20	111.4	1324	1266	Atlas/Agena
EGRS V	69.24	122.2	2427	1135	Scout
GEOS A	59.38	120.3	2273	1119	TAD/Delta
EGRS VI	90.04	125.2	3655	171	Atlas/Agena
EGRS VII	90.01	167.9	3743	3686	Atlas/Agena
EGRS VIII	90.19	167.6	3704	3677	Atlas/Agena
EGRS IX	89.80	172.1	3945	3794	Thor/Burner II
GEOS B	105.80	112.2	1573	1080	Thor/Delta
EGRS X	99.00	106.0	1100	1100	Thorad/Agena
EGRS XI	91.30	172.0	3900	3900	Atlas/Burner II
EGRS XII	91.30	172.0	3900	3900	Atlas/Burner II
EGRS XIII	99.90	107.3	1141	1085	Thorad/Agena
TOPO I	99.86	107.0	1090	1081	Thorad/Agena

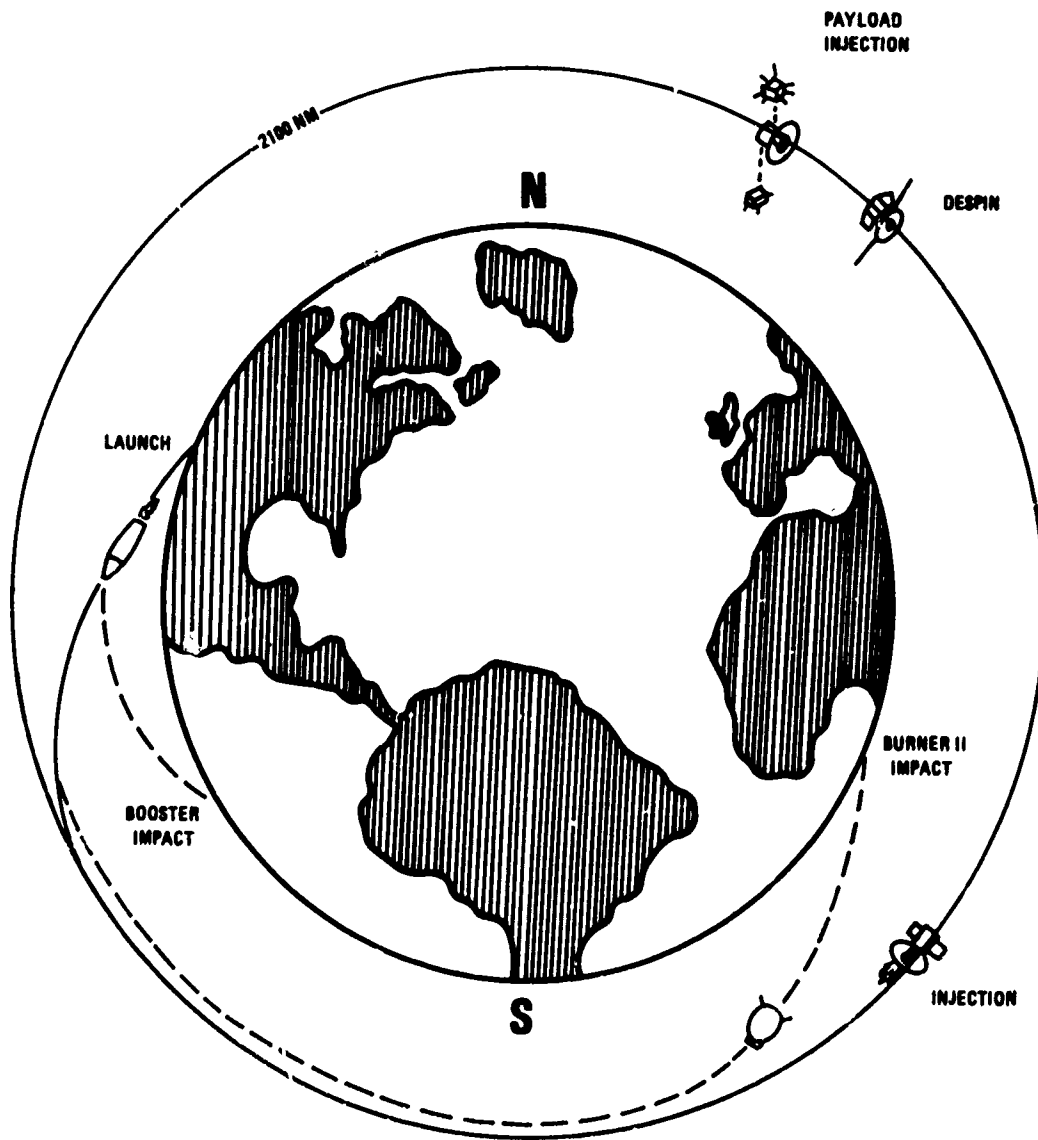

Figure 7. Launch sequence example.

APPENDIX
SECOR SPACE LOG

The following is a summary of each launch:

Transmit III B. A SECOR TR-17 transponder was launched as part of the Transit IIIB/Lofti 1 experiment headed by the U. S. Navy. The 300-pound payload was launched from Cape Kennedy (Eastern Test Range); however, failure of the vehicle's second stage to separate prevented the satellite from achieving useful orbit. Because of a very low perigee (117 nautical miles), the stage re-entered the Earth's atmosphere 38 days after launch.

Discoverer 32. An identical SECOR transponder was launched along with Discoverer 32; this was one of the many satellites in the U. S. Air Force Discoverer series. No actual separation of the SECOR payload was planned. The satellite decayed 1 month after launch, but limited R&D information via the SECOR ground station was obtained. It is also noteworthy that mid-air capsule recovery was completed on the 18th orbit.

Discoverer 34. Except for achieving a final orbit which was quite elliptical, this launch was intended to be a carbon copy of Discoverer 32. However, a vehicle malfunction prevented capsule ejection, and therefore no useful SECOR data were obtained.

Discoverer 36. This launch was also a copy of Discoverer 32, except for the addition of the Oscar 1 payload; this was the first "ham" satellite. Again there was no plan to separate the SECOR transponder, but useful data were obtained. Decay occurred 80 days after launch.

Composite 1. This launch, under direction of the U. S. Navy, carried five separate satellites including the first SECOR satellite. Again, a TR-17 transponder was used, but this time it was housed in a SECOR Type I spherical satellite. Because of low second-stage thrust, the payloads failed to achieve orbit.

ANNA 1A. On previous launches, when a transponder was provided by the U. S. Army, the TR-17's were attached to the upper stage of the launch vehicle and the entire stage acted as a final payload. ANNA, however, was a self-contained spacecraft incorporating several experiments, including an improved SECOR transponder (the TR-27). The 355-pound spacecraft was designed and built by Johns Hopkins University/Applied Physics Laboratory under the direction of NASA. Unfortunately, a second-stage ignition malfunction prevented spacecraft orbit.

ANNA 1B. This launch was quite similar to the previous ANNA experiment; however, in this case, two SECOR TR-27 transponders were deployed. The spacecraft achieved a good orbit, but success was limited to 3 weeks insofar as SECOR was concerned. The switching mechanism, designed to connect either of the two TR-27's to the battery provided for SECOR, failed after an unknown problem developed in one of the transponders. The switch failure caused the battery to discharge completely, thereby ending SECOR operation.

EGRS 1. The launching of EGRS 1 from the Western Test Range should be considered the beginning of a successful SECOR program. The TAT-Agena D rocket hurled five satellites into near-perfect circular orbits. The payloads included two classified experiments, a gravity-gradient stabilization experiment, a solar radiation satellite, and the newly developed U. S. Army Type II satellite. The cube-shaped spacecraft was developed by ITT Federal Laboratories for GIMRADA. EGRS 1 operated successfully for more than 1-1/2 years, was used throughout ET/EST, and was credited with providing the initial tie between Japan and Hawaii. The battery life, which was designed for 1 year, finally degenerated beyond usefulness in September of 1965.

EGRS 3. Because of schedule slippages, EGRS 3 was launched prior to EGRS 2. Again utilizing a TR-27 transponder, EGRS 3 was highly successful—not only in achieving a near circular polar orbit but in the functioning of the Type II satellite. This particular mission was headed by the U. S. Air Force, and eight separate payloads were delivered into orbit. The intercontinental tie between Japan and Hawaii was successfully completed by the SECOR ground stations. The orbital altitude, however, was too low to be very useful in completing the SECOR equatorial belt. By consistent exercising of the satellite batteries, their lifetime was vastly extended; this particular satellite was operational longer than any of the SECOR satellites—approximately 3 years.

EGRS 2. This Type-II SECOR-satellite/TR-27-transponder combination was launched, along with a classified U. S. Navy payload, in an unusual manner, GIMRADA worked closely with the primary payload from Naval Avionics Facilities (Indianapolis). The Navy satellite was attached to the top of a 6-foot cylinder, which contained a cutout reserved for a Type II satellite. The SECOR satellite was properly placed within the cutout. Large solar panels (or "wings") were then folded down from the Navy satellite, covering the SECOR satellite. A band was wrapped around the spring-loaded solar panels, and the entire unit was launched into a near-perfect orbit. The SECOR telemetry operated for a few days, then faded. It was suspected that the explosive cap, which was to release the retaining band to allow the solar panels to extend themselves, did not fire. The sequence following this event included firing another cap to eject the SECOR satellite. This obviously occurred. The Type II must have sprung forward an inch or so, but was trapped by the solar panels since partial separation was

necessary to allow the telemetry to function. The transponder could not be interrogated, and with no sunlight on the SECOR solar cells, the batteries soon discharged.

EGRS 4. Code-named "Snapshot," this launch carried a classified payload, a SNAP-10A Air Force satellite, and a SECOR Type II satellite. The transponder was a major departure from previous models, since it used the "open loop" approach; it was designed and built by ITT Federal Laboratories. An undetermined malfunction, apparently in the transponder, rendered the satellite unusable.

The launch itself was good in that the polar orbit and injection was very near nominal. NASA had conducted extensive studies to insure that there would be no ill effects from solar radiation and to make certain that the payloads would be injected in such a way that future collision would be an impossibility.

Although the "open loop" characteristic of the SECOR transponder remained desirable, further use of the C-101 transponder was not recommended.

EGRS 5. Up to this point, SECOR was delegated the role of a secondary payload, thereby incurring little or no launch cost. NASA had built a Scout rocket and was in the process of completing an experiment fourth stage. GIMRADA was advised that there was limited space available for a single payload. After studying the mechanical characteristics of the Army Type I SECOR satellite, it was announced that the satellite was desirable for the forthcoming launch—as primary payload. Notification was given to prepare and launch a Type I from Wallops Island, Virginia, within 7 months. The task was met by preparing the satellite through an in-house effort.

On launch day, the final burn of the Scout rocket raised the apogee 300 nautical miles beyond expected limits, placing the SECOR satellite in a highly elliptical orbit. The fourth stage was "spun-up" to a nominal 180 rpm. The satellite spin was quite normal for the first five orbits, after which the despin rate suddenly became very low, possibly due to transfer of spin axis. The date of total despin was projected to be the Summer of 1966, but all signals from the satellite ceased on 3 March 1966—reason unknown.

It was anticipated that the satellite would be unusable until the spin rate dropped to less than 1 rpm, but, due to the shift in spin axis, the time required far exceeded the anticipated 30 days.

GEOS A. The GEOS launches were a continuation of the earlier ANNA series. Applied Physics Laboratory (APL) was appointed by NASA to prepare the satellite, which had among other systems an Army SECOR transponder, the TR-27. Since some systems aboard the GEOS satellite were operated simultaneously and since some shared

power sources and antennas, numerous system integration problems were anticipated. Extensive RFI problems were noted during pre-launch tests at APL; these were primarily due to interaction between the 324-MHz doppler transmitter and the SECOR receiver. The result was a "ballooning" between SECOR data bursts, as noted on an oscilloscope, during the one-station, keyed mode of operation. When the doppler transmitter was turned off, the trouble was removed. Efforts were made to minimize the effect by using extensive shielding, but total isolation was never achieved.

The SECOR system aboard GEOS proved to be a "workhorse," successfully filling a gap between SECOR satellite launches.

EGRS 6. On this mission, a Type II SECOR satellite was launched along with a classified payload and an Environmental Research Spacecraft (ERS-16) which contained five metal-to-metal bonding (cold-welding) experiments. The SECOR satellite carried the new all-transistorized TR-30A transponder built by Cubic Corporation.

During the attempt to place the final stage in orbit, the circularizing burn failed to ignite, resulting in a highly elliptical orbit.

The rapidly diminishing apogee resulted in premature re-entry.

Aside from poor orbit conditions, indications at the SECOR ground stations were that data from the new transponder contained spurious oscillations. The exact cause was undetermined.

EGRS 7. This was the second attempt at launching the TR-30A transponder. The Type II satellite was placed in good orbit, but a problem similar to the one noted in EGRS 6 was evident. The SECOR data were somewhat intermittent. Ground stations frequently lost lock during the satellite pass, making it necessary to re-acquire, which resulted in a 50 percent loss of data during each pass.

A subtle problem was subsequently located in the data feedback loop of similar transponders. The "loop gain" adjustment in the manufacturer's final alignment procedure proved to be incorrect and went unnoticed during prelaunch tests (primarily due to lack of a facility to make such a test with the satellite sealed). A correction was made in alignment procedures, and a facility was incorporated on the Type II satellite to test this parameter prior to launch.

EGRS 8. This launch was almost identical to EGRS 7. The SECOR package was an identical configuration, and again the satellite was placed in a good orbit. However, another transponder malfunction occurred, rendering the satellite inoperative. The

trouble was traced to a broken or unconnected linkage between the satellite's antenna and the transponder.

EGRS 9. An Air Force Burner II upper stage, built by Boeing Company, was used in conjunction with a newly developed stage to place two satellites in Earth orbits. A SECOR satellite, the primary payload, and an Aurora satellite, developed by Rice University for the Office of Naval Research, were placed in 2100-nautical-mile orbits via a Thor/Burner II combination. A new injection stage, or "payload dispenser", intended to carry two satellites on top of the Burner II stage, was built, designed, and tested. The satellites were mounted on opposite sides of the injection stage which housed a 1400-pound-thrust, solid propellant rocket motor. All aspects of the launch proved successful.

GEOS B. More extensive compatibility tests were conducted in an effort to avoid the RFI problems encountered on GEOS A. In addition, the more sensitive TR-30 SECOR transponder was used, but in a shielded version with the nomenclature, TR-30A/S.

On the GEOS A launch, it was noted that temperatures encountered in orbit were more severe on certain systems than on others. This was found to be due to the physical location of the experiment on the GEOS satellite. One side of the satellite was in sunlight far more often (hence greater temperature) than the other. A "heat pipe" filled with Freon fluid was devised by APL to transfer heat from one side of the satellite to the other. The pipe was directly connected to the SECOR transponder and subsequently provided much improved temperature regulation. Overall performance of the SECOR was again successful.

EGRS 10. A SECOR satellite was launched along with the 1200-pound Nimbus weather satellite. It was the Army's first attempt to launch the newest SECOR transponder, the Multi-Altitude Transponder (MAT).

Unfortunately, the launch vehicle veered off course and had to be destroyed.

EGRS 11 and EGRS 12. The Air Force Space Experiments Support Program planned this unique launch. It was the first time for an Atlas/Burner II combination, which was to place 10 satellites in different orbits via three orbital shuttles. The following payloads were launched:

- a. Orbis-Cal—To study bending of RF energy in the ionosphere.
- b. Lidos—To determine the earth's mean equatorial radius.
- c. LCS 3—Radar and communication calibration.
- d. Radcat—A target for radar calibration.

- e. OV5-A--To study materiel's friction behavior.
- f. Grid Sphere Drag--To study aerodynamic characteristics.
- g. RM-18--To measure fine structure of the earth's background.
- h. UV Radiometer--To study navigation using UV radiance.
- i. EGRS 11--Geodetic measurements.
- j. EGRS 12--Geodetic measurements.

As noted, two SECOR satellites were launched; they would not only provide increased data but would allow for a direct comparison of the two latest transponder designs. EGRS 11 was equipped with a TR-30B High-Altitude Transponder (HAT), developed by Cubic Corporation. EGRS 12 contained a MAT developed by ITT. None of the experiments succeeded, however, since the "heat shield," which was part of the launch vehicle and was used as a shroud to protect the payloads, failed to separate.

EGRS 13. The successful launching of this TR-30B/Type II satellite was the major milestone in the SECOR Program. The spacecraft, which was launched along with Nimbus B-2, performed well, and the final measurements to complete the geodetic belt were established.

Extensive studies were made prior to this launch, due to increasing concern for possible orbital collision of the satellites. The upper stage of the launch vehicle was equipped with maneuverability after separation, so that Nimbus, SECOR, and the stage itself could be placed in different orbits.

TOPO I. This launch, part of the Nimbus series, was to be the last for SECOR. Nine experiments attached to Nimbus were launched along with the MAT/Type II combination. A high tumble rate was imparted to the SECOR satellite, rendering it unusable for the first few days. Once the tumble subsided to less than 1 rpm, the satellite performed well, providing exceptionally clean data and high compatibility with the miniaturized ground stations. TOPO I was used primarily for research and development in determining the ultimate accuracy of SECOR when using transponders with ultra-stable oscillators.