

**COMMUNICATIONS
ALLIANCE LTD**



AUSTRALIAN STANDARD

AS/CA S003.1:2010

Requirements for Customer Access Equipment for
connection to a Telecommunications Network —
Part 1: General

**Adopted for
regulatory purposes**

Australian Standard – Requirements for Customer Access Equipment for connection to a Telecommunications Network — Part 1: General

This Standard was issued in draft form for public comment as DR AS/CA S003.1:2009

First published as AS/ACIF S003:1999

Second edition as AS/ACIF S003:2001

Third edition as AS/ACIF S003:2005

Fourth edition as AS/ACIF S003:2006

Fifth edition as AS/ACIF S003:2008

ISBN: 1 74000 394 2

Communications Alliance Ltd (formerly Australian Communications Industry Forum Ltd) was formed in 2006 to provide a unified voice for the Australian communications industry and to lead it into the next generation of converging networks, technologies and services.

Disclaimers

1. Notwithstanding anything contained in this Standard:
 - (a) Communications Alliance disclaims responsibility (including where Communications Alliance or any of its officers, employees, agents or contractors has been negligent) for any direct or indirect loss, damage, claim, or liability any person may incur as a result of any:
 - (i) reliance on or compliance with this Standard;
 - (ii) inaccuracy or inappropriateness of this Standard; or
 - (iii) inconsistency of this Standard with any law; and
 - (b) Communications Alliance disclaims responsibility (including where Communications Alliance or any of its officers, employees, agents or contractors has been negligent) for ensuring compliance by any person with this Standard.
2. The above disclaimers will not apply to the extent they are inconsistent with any relevant legislation.

Copyright

© Commonwealth of Australia 2010

This work is copyright. Apart from any use as permitted under the Copyright Act 1968, no part may be reproduced by any process without prior written permission from the Commonwealth available from AusInfo. Requests and inquiries concerning reproduction and rights should be addressed to the Manager, Legislative Services, AusInfo, GPO Box 1920, Canberra ACT 2601 or by email to cwealthcopyright@dofa.gov.au

FOREWORD

General

This Standard was prepared by the Communications Alliance WC20 : **Customer Access Equipment Revision** Working Committee. It is one of a series of Telecommunication Standards developed under the Memorandum of Understanding between the Australian Communications Authority (ACA) and the Australian Communications Industry Forum.

Note: On 1 July 2005 the ACA became the Australian Communications and Media Authority (ACMA) and the Memorandum of Understanding continues in effect as if the reference to the ACA were a reference to ACMA.

This Standard is a revision of the AS/ACIF S003:2005 and AS/ACIF S003:2008 *Customer Access Equipment for connection to a Telecommunications Network* Standards. This Standard is the result of a consensus among representatives on the Communications Alliance Working Committee to produce it as an Australian Standard.

The designation of this Standard has been changed from AS/ACIF to AS/CA to reflect that the Standard has been published by Communications Alliance as an accredited Standards Development Organisation.

The requirements in this Standard are consistent with the aims of s376 of the *Telecommunications Act 1997*. Specifically these aims are—

- (a) protecting the integrity of a telecommunications network or facility;
- (b) protecting the health and safety of persons;
- (c) ensuring access to emergency services; and
- (d) ensuring interoperability with a standard telephone service.

It should be noted that some Customer Equipment (CE) may also need to comply with requirements in other Standards or other Parts of this Standard.

AS/CA S003 consists of the following parts under the general title *Requirements for Customer Access Equipment for connection to a Telecommunications Network*:

- *Part 1: General*
- *Part 2: Analogue and TDM based technologies*
- *Part 3: Packet and cell based technologies*

Applicable electrical safety Standards and EMC Standards may apply under Commonwealth or State laws, or both.

Intellectual property rights

Equipment which is manufactured to comply with this Standard may require the use of technology which is protected by patent rights in Australia. Questions about the availability of such technology, under licence or otherwise, should be directed to the patent holder or Australian licensee (if known) or through enquiry at IP Australia which incorporates the Patent, Designs and Trade Marks Offices. Further information can be found at www.ipaustralia.gov.au.

Standards revision

Australian Standards (AS/ACIF and AS/CA Standards) developed by the Australian Communications Industry Forum, a division of Communications Alliance, are updated, according to the needs of the industry, by amendments or revision. Users of these Standards should make sure that they possess the latest amendments or editions. Representations concerning the need for a change to this AS/CA Standard should be addressed to:

The Project Manager
Customer Equipment and Cable Reference Panel
Communications Alliance
PO Box 444
Milsons Point NSW 1565

Regulatory notice

This document has been made by ACMA as Telecommunications Technical Standard AS/CA S003.1–2010 under s376 of the *Telecommunications Act 1997*.

ACMA is a Commonwealth authority with statutory powers to impose requirements concerning telecommunications Customer Equipment and Customer Cabling.

ACMA requires Australian manufacturers and importers, or their Australian agents, of specified items of Customer Equipment and Customer Cabling to establish compliance with Standards such as this. Items are required to be labelled in accordance with the applicable labelling notices.

Details on current compliance arrangements can be obtained from the ACMA website at <http://www.acma.gov.au> or by contacting ACMA below at:

Australian Communications and Media Authority
PO Box 13112
Law Courts PO
Melbourne VIC 8010
Australia

Telephone: +61 3 9963 6800
Facsimile: +61 3 9963 6899
TTY: +61 3 9963 6948

Introduction

This introduction for the AS/CA S003.1 **Australian Standard – Requirements for Customer Access Equipment for connection to a Telecommunications Network — Part 1: General** Standard is not an authoritative section of this Standard and is only provided as guidance for the user of the Standard to outline its objectives, and the factors that have been taken into account in its development.

The reader is directed to the clauses of this Standard for the specific requirements and to the Australian Communications and Media Authority (ACMA) for the applicable telecommunications labelling and compliance arrangements.

Note: Further information on the telecommunications labelling and compliance arrangements can be found in *The Telecommunications Labelling (Customer Equipment and Customer Cabling) Notice* (the TLN). The TLN can be obtained from the Australian Communications and Media Authority (ACMA) website at www.acma.gov.au.

The objective of this Standard is to provide the requirements and test methods for customer equipment that provides access (gateway functions) to a Telecommunications Network in order to meet the regulatory arrangements for such equipment in Australia. The objective of Part 1 of this Standard is to provide requirements that are common to all for Customer Access Equipment (CAE).

The objective of this revision is to divide the requirements for CAE into technology specific Parts to facilitate compliance of CAE that use analogue/TDM based technologies, packet/cell based technologies or both.

The principal differences between this edition of AS/CA S003.1 and the 2005 and 2008 editions of AS/ACIF S003 are the following:

- (a) Requirements specific to analogue and/or PCM-based TDM technologies and Packet/cell based technologies have been separated and included in AS/CA S003.2 and AS/CA S003.3. Only general requirements that are common to CAE are included in AS/CA S003.1.
- (b) The exclusion of the noise requirement on ring signals where the local port is not intended to be connected to building cabling, which was missing from the 2008 edition, has been restored.
- (c) The term 'Industry Based Proprietary Terminals' has been replaced by 'System Integral Terminals' and abbreviated as 'SIT'.
- (d) A note has been added to clarify that an Appendix C compliant SIT connection may require dedicated cabling in cases where interference may occur.
- (e) The technology specific transmission performance requirements are now specified in Parts 2 and 3.
- (f) The conference bridge performance requirements have been relocated to the new Appendix E.
- (g) Clarification of the connection method of earthing requirements for functional purposes and the exclusion of the use of a mains power plug for this purpose.

TABLE OF CONTENTS

1	INTERPRETATIVE GUIDELINES	1
	1.1 Categories of requirements	1
	1.2 Compliance statements	1
	1.3 Definitions, expressions and terms	1
	1.4 Notes	1
	1.5 References	1
	1.6 Units and symbols	1
	1.7 Parts of Standards	2
2	SCOPE	3
3	REFERENCES	4
4	ABBREVIATIONS AND DEFINITIONS	6
	4.1 Abbreviations	6
	4.2 Definitions	7
	4.2.1 Answer signal	7
	4.2.2 Automatic Guard	7
	4.2.3 Blocking Signal (Back Busy)	7
	4.2.4 Building Cabling Environment	7
	4.2.5 Carriage Service Provider	7
	4.2.6 Carrier	7
	4.2.7 Channel Associated Signalling (CAS)	7
	4.2.8 Clear Back signal	7
	4.2.9 Clear Forward signal	7
	4.2.10 Conference bridge	7
	4.2.11 Customer Access Equipment (CAE)	7
	4.2.12 Customer Equipment (CE)	8
	4.2.13 Customer Switching System (CSS)	8
	4.2.14 Decadic signalling	8
	4.2.15 Dialling	8
	4.2.16 Digital network interface	8
	4.2.17 Direct Inwards System Access (DISA)	8
	4.2.18 Dual Tone Multifrequency Signalling (DTMF)	8
	4.2.19 E & M Signalling	9
	4.2.20 Exchange line	9
	4.2.21 Extension line	9
	4.2.22 External extension	9
	4.2.23 Functional Earth (FE)	9
	4.2.24 Hold	9
	4.2.25 Industry Based Proprietary Terminal (IBPT)	9

4.2.26	<i>Integrated Access Device (IAD)</i>	9
4.2.27	<i>Local Port (Off Premises)</i>	9
4.2.28	<i>Local Port (On Premises)</i>	10
4.2.29	<i>Network Port</i>	10
4.2.30	<i>Network Port (Digital)</i>	10
4.2.31	<i>Network Port (Four wire E&M)</i>	10
4.2.32	<i>Network Port (Indial)</i>	10
4.2.33	<i>Network Port (Loop-in)</i>	10
4.2.34	<i>Network Port (Ring-in/Loop-out)</i>	10
4.2.35	<i>Point of zero relative level (0 dBr point)</i>	10
4.2.36	<i>Port</i>	10
4.2.37	<i>Protective Earth (PE)</i>	11
4.2.38	<i>Public Switched Telephone Network (PSTN)</i>	11
4.2.39	<i>Recall Backward</i>	11
4.2.40	<i>Recall Forward</i>	11
4.2.41	<i>Release Guard</i>	11
4.2.42	<i>Reversal on Seizure</i>	11
4.2.43	<i>Reversal On Answer</i>	11
4.2.44	<i>Ringer Equivalence Number (REN)</i>	11
4.2.45	<i>Seize Acknowledge signal (Proceed to Send)</i>	12
4.2.46	<i>Seize signal</i>	12
4.2.47	<i>Standard telephone instrument</i>	12
4.2.48	<i>System Integral Terminal</i>	12
4.2.49	<i>Telecommunications Network</i>	12
4.2.50	<i>Telecommunications Reference Conductor (TRC)</i>	12
4.2.51	<i>Tie Line Port</i>	12
4.2.52	<i>Voice Frequency (VF)</i>	13
4.2.53	<i>Voiceband</i>	13
5	REQUIREMENTS	14
5.1	General	14
5.1.1	<i>Power failure</i>	14
5.1.2	<i>Network Port calls</i>	14
5.1.3	<i>Functional Earth connection and Protective Earth connection</i>	14
5.1.4	<i>Emergency services access</i>	16
5.1.5	<i>Security of dialled information</i>	17
5.1.6	<i>Security of incoming automatically answered calls</i>	17
5.1.7	<i>Indial requirements for CE</i>	17
5.2	Network Ports (Ring-in/Loop-out)	18
5.2.1	<i>General</i>	18

5.2.2	<i>Common requirements</i>	19
5.2.3	<i>Automatic bothway operation</i>	22
5.3	Standard analogue telephone Local Port (On Premises and Off Premises)	24
5.3.1	<i>General</i>	24
5.3.2	<i>Line signals</i>	24
5.3.3	<i>Address signals</i>	26
5.4	System Integral Terminals	27
5.4.1	<i>Voice Frequency Performance</i>	27
5.4.2	<i>Signal levels</i>	28
5.4.3	<i>Balance about earth</i>	28
5.4.4	<i>Return loss</i>	28
5.5	Transmission requirements	28
5.5.1	<i>General</i>	28
5.6	Analogue Tie Line Network Ports	31
5.6.1	<i>C2 Series signals</i>	31
5.6.2	<i>Line signalling tolerances</i>	33
5.7	Digital Tie Line Ports	35
5.7.1	<i>General</i>	35
5.7.2	<i>n x 64 kbit/s service</i>	35
5.8	Digital PSTN Network Ports	35
5.8.1	<i>General</i>	35
5.8.2	<i>n x 64 kbit/s service</i>	36
5.8.3	<i>Emergency services access</i>	36
5.8.4	<i>Security of dialled information</i>	36
5.8.5	<i>Security of incoming automatically answered calls</i>	36
5.8.6	<i>Automatic bothway operation</i>	36
5.8.7	<i>Automatic answering of incoming calls</i>	36
5.9	ISDN Network Ports	37
5.10	Conference bridges	37
6	TESTING	38
6.1	Verification of compliance with requirements	38
6.2	Standard test conditions	38
6.3	Test configurations	39
6.4	Test level	39
6.5	Test frequencies	39
6.6	Parameters to be tested	39
6.6.1	<i>Early Guard – Incoming/Reversal on Seizure</i>	39
6.6.2	<i>Release blocking</i>	39

6.6.3	<i>Automatic Guard</i>	39
6.6.4	<i>Line leakage resistance</i>	40
6.6.5	<i>Measurement of ring signal characteristics</i>	40
6.6.6	<i>Answer/Seizure/Hold signals</i>	41
6.6.7	<i>Idle/Release signals</i>	41
6.6.8	<i>Decadic signals</i>	41
6.6.9	<i>DTMF signals</i>	41
6.6.10	<i>Local Port (Off Premises)</i>	41
6.6.11	<i>Recall signal</i>	41
6.6.12	<i>Transmission measurements</i>	42
6.6.13	<i>Power Spectral Density should be measured using the following:</i>	42

PARTICIPANTS	82
---------------------	-----------

APPENDICES

A1	General	51
A2	CE Interface with E & M Signalling (including C2)	51
A3	Proceed to send – Wink Start (outgoing call to PSTN)	53
B1	General	57
B2	Signalling	57
B3	Timing	59
B4	Action on faults and transmission degradation	60
B5	Summary of actions appropriate to various signals	61
C1	General	70
C2	Requirements	70
C3	Parameters to be Tested	72
D1	Conference supervision	78
E1	General	80
E2	Digital Network Interfaces	80

FIGURES

1	Ring Signal Power Levels limits above 3.4 kHz	43
2	Reference impedance (TN12) for impedance measurement	43
3	C2 Series signalling	44
4	Early Guard (polarity reversal) and release blocking	45
5	Early Guard (immediate ring)	45
6	Automatic Guard	46
7	Line leakage resistance	46
8	Harmonic content of ring signal	47

9	Answer/Seizure/Hold/Idle/Release/Facility signals	47
10	Decadic signals	48
11	DTMF signals	48
12	Transmission measurement configuration	49
13	Measurement of ring signals	50
A1	Four-wire CE interface with E & M Signalling	53
A2	Test circuit for E & M Signalling – M-Lead voltage drop; M-Lead continuous current and M-Lead leakage current tests	54
A3	Test circuit for E & M Signalling limits	54
A4	Test circuit for E & M Signalling limits E-Lead sensitivity test	55
A5	Test circuit for E & M Signalling – E-Lead open circuit and leakage test	56
B1	CAS Line signalling functions – outgoing calls State and transition diagram (Sheet 1 of 2)	65
B2	CAS Line signalling functions – outgoing calls State and transition diagram (Sheet 2 of 2)	66
B3	CAS Line signalling functions – outgoing calls Legend	67
B4	CAS Line signalling functions – incoming calls State and transition diagram	68
B5	CAS Line signalling functions – incoming calls Legend	69
C1	Power Level Limits Above 3.4 kHz	75
C2	Longitudinal Power Level Limits	75
C3	Signal Power Level Limit in any 3 kHz Band	76
C4	Longitudinal Power Level Limits (Wideband Signals)	76
C5	Test Circuit for Measurement of Longitudinal Power Level	77
E1	CAE connections	80

TABLES

1	Line Polarity for Reversal-on-Seizure	21
2	Line Polarity for Reversal-on-Answer	22
3	DC terminations	29
4	Port and balance network impedances	29
5	PSD within a 1 MHz sliding window	30
6	C2 Series signalling codes (Earth-on-Idle)	32
7	C2 Series signalling codes (Earth-off-Idle)	33
8	Sending tolerances	34
9	Receiving tolerances	34
A1	E & M Signalling states – CE to PSTN	52
A2	E & M Signalling states – PSTN to CE	52
B1	Signalling codes – Outgoing call	58
B2	Signalling codes – Incoming call	58
B3	Timing limits – Outgoing call	59
B4	Timing limits – Incoming call	59
B5	Signalling conditions – originating call from the CE	61
B6	Signalling conditions – incoming call to the CE	63
E1	Terminology Cross-reference Table	81

1 INTERPRETATIVE GUIDELINES

1.1 Categories of requirements

This Standard contains mandatory requirements as well as provisions that are recommendatory only. Mandatory requirements are designated by the words '**shall**' or '**shall not**'. All other provisions are voluntary.

1.2 Compliance statements

Compliance statements, in italics, suggest methodologies for demonstrating CE's compliance with the requirements.

1.3 Definitions, expressions and terms

If there is any conflict between the definitions used in this Standard and the definitions used in the *Telecommunications Act 1997*, the definitions in the Act take precedence.

1.4 Notes

Text denoted as 'Note' is for guidance in interpretation and is shown in smaller size type.

1.5 References

- (a) Applicable editions (or versions) of other documents referred to in this Standard are specified in Section 3: REFERENCES.
- (b) If a document refers to another document, the other document is a sub-referenced document.
- (c) Where the edition (or version) of the sub-referenced document is uniquely identified in the reference document, then that edition (or version) applies.
- (d) Where the edition (or version) of the sub-referenced document is not uniquely identified in the reference document, then the applicable edition (or version) is that which is current at the date the reference document is legislated under the applicable regulatory framework, or for a non-legislated document, the date upon which the document is published by the relevant standards organisation.
- (e) A number in square brackets '[]' refers to a document listed in Section 3: REFERENCES.

1.6 Units and symbols

In this Standard the International System (SI) of units and symbols is used in accordance with Australian Standard AS ISO 1000 [2].

1.7 Parts of Standards

Customer Equipment (CE) scoped by this Standard is to comply with requirements in Part 1 and the applicable technology-specific Part of this Standard.

2 SCOPE

- 2.1 This Standard applies to Customer Equipment (CE) that is—
- (a) designed with multiple ports (local or network) that provides or is intended to provide access (gateway functions) to a Telecommunications Network; and
 - (b) capable of switching, storage, processing, conversion, integration, line isolation/coupling or multiplexing of analogue or digital voice or voice equivalent communication.
- 2.2 CE is not excluded from the scope of this Standard by reason only that it is capable of performing functions additional to those described in this Standard.

3 REFERENCES

	Publication	Title
	ACMA Technical Standard	
[1]	ACA TS 014 - 1997	General Requirements for Customer Equipment Connected to ISDN Primary Rate Access
	Australian Standards	
[2]	AS ISO 1000-1998	The international System of Unit (SI) and its application.
[3]	AS/NZS 3015:2004	Electrical installations - Extra-low voltage d.c. power supplies and service earthing within public telecommunications networks
[4]	AS/NZS 60950.1:2003	Safety of information technology equipment
	AS/ACIF Standards	
[5]	AS/ACIF S002:2005	Analogue interworking and non-interference requirements for Customer Equipment for connection to the Public Switched Telephone Network
[6]	AS/ACIF S004:2008	Voice frequency performance requirements for Customer Equipment.
[7]	AS/ACIF S016:2001	Requirements for Customer Equipment for connection to hierarchical digital interfaces
[8]	AS/ACIF S031:2001	Requirements for ISDN Basic Access Interface
[9]	AS/ACIF S038:2001	Requirements for ISDN Primary Rate Access Interface
[10]	AS/ACIF S043	Requirements for Customer Equipment for connection to a metallic local loop interface of a Telecommunications Network
[11]	AS/ACIF S043.1:2003	Part 1: General
[12]	AS/ACIF S043.2:2008	Part 2: Broadband
[13]	AS/ACIF S043.3:2008	Part 3: DC, low frequency AC and voiceband
	ANSI Standard	
[14]	T1.601:1998	ISDN Basic Access Interface for Use on Metallic Loops for Application at the Network Side of NT, Layer 1 Specification

	Publication	Title
	ITU-T Recommendations	
[16]	G.223 (11/88)	Assumptions for the calculations of noise on hypothetical reference circuits for telephony
[17]	G.704 (10/98)	Synchronous frame structures used at primary and secondary hierarchical levels
[18]	G.711 (11/88)	Pulse code modulation (PCM) of voice frequencies
[19]	G.732 (11/88)	Characteristics of primary PCM Multiplex equipment operating at 2048 kbit/s
[20]	O.9 (03/99)	Measuring arrangements to access the degree of unbalance about earth
[21]	O.41 (10/94)	Psophometer for use on telephone type circuits
[22]	O.71 (11/88)	Impulsive noise measuring equipment for telephone type circuits
	ETSI Standards	
[23]	ES 201 168 V1.2.1 (2000-10)	Speech Processing, Transmission and Quality Aspects (STQ); Transmission characteristics of digital Private Branch eXchanges (PBXs) for interconnection to private networks, to the public switched network or to IP gateways

4 ABBREVIATIONS AND DEFINITIONS

For the purposes of this Standard, the following abbreviations and definitions apply:

4.1 Abbreviations

AC	Alternating Current
ACIF	Australian Communications Industry Forum
ACMA	Australian Communications and Media Authority
AGC	Automatic Gain Control
AS	Australian Standard
CAE	Customer Access Equipment
CAS	Channel Associated Signalling
CE	Customer Equipment
CSH	Call Still Held
CSS	Customer Switching System(s)
DC	Direct Current
DISA	Direct Inwards System Access
DTMF	Dual Tone Multifrequency
FE	Functional Earth
IAD	Integrated Access Device
ISDN	Integrated Services Digital Network
ISO	International Standardization Organization
LCL	Longitudinal Conversion Loss
LCTL	Longitudinal Conversion Transfer Loss
MFC	Multifrequency Code
NU	Number Unobtainable
NZS	New Zealand Standard
PCM	Pulse Code Modulation
PE	Protective Earth
PIN	Personal Identification Number
PSD	Power Spectral Density
PSTN	Public Switched Telephone Network
REN	Ringer Equivalence Number
RVA	Recorded Voice Announcement
SA	Service Alarm
SIT	System Integral Terminal
TBRL	Terminal Balance Return Loss
TCL	Transverse Conversion Loss
TCTL	Transverse Conversion Transfer Loss
TRC	Telecommunications Reference Conductor
VF	Voice Frequency

4.2 Definitions

4.2.1 Answer signal

A signal which is sent in the backward direction to indicate that the called party has answered.

Note: This signal has a supervisory function.

4.2.2 Automatic Guard

A facility within the CE that prevents the seizure of faulty or incompletely released PSTN lines by the CE.

4.2.3 Blocking Signal (Back Busy)

A signal which is sent in the backward direction and causes a busy condition to be applied at the far end of the link.

4.2.4 Building Cabling Environment

Customer cabling contained within a single building.

4.2.5 Carriage Service Provider

Refer to the *Telecommunications Act 1997*.

4.2.6 Carrier

Refer to the *Telecommunications Act 1997*.

4.2.7 Channel Associated Signalling (CAS)

A signalling method in which the signals necessary for the traffic carried by a single channel are transmitted in the channel itself or in a signalling channel permanently dedicated to it.

4.2.8 Clear Back signal

A signal which is sent in the backward direction to indicate that the called party has cleared.

Note: This signal initiates circuit clearing and indicates that the incoming end has released.

4.2.9 Clear Forward signal

A signal which is sent in the forward direction to initiate the release of the connection.

4.2.10 Conference bridge

Equipment that provides a connection for calls involving more than two external lines (Local Ports (off-premises) or Network Ports).

4.2.11 Customer Access Equipment (CAE)

CE with multiple ports (local or network) that provides access (gateway functions) to a Telecommunications Network and is capable of switching, storage, processing, conversion, integration,

line isolation/coupling or multiplexing of analogue or digital voice or voice equivalent communication.

Note: Examples of CAE include, but are not limited to, PABX or Key Systems, line isolators, ISDN terminal adapters, echo cancellers, interactive voice response systems, voice/packet gateway, IAD and voice messaging systems.

4.2.12 Customer Equipment (CE)

Refer to the *Telecommunications Act 1997*.

4.2.13 Customer Switching System (CSS)

See Customer Access Equipment.

4.2.14 Decadic signalling

A system for transmitting address information by a succession of loop-disconnect, or earth referenced E & M, break pulses. The break pulses momentarily interrupt the established direct current in the circuit. The number of pulses transmitted for a digit corresponds to the numerical value of the digit, with 10 pulses being transmitted for the digit 0.

Note: Where 2 Mbit/s Channel Associated Signalling is used, Decadic Signalling is transferred by bit pattern toggling of the 'a' and 'b' bits in Timeslot 16 for the particular channel in use. See Appendix B for further information.

4.2.15 Dialling

In this Standard, the terms 'dials' and 'dialling' refer to the transmission of address information by a telephone-type rotary dial or push-button key pad, and the transmission of the signals to line from such devices or from a storage device.

4.2.16 Digital network interface

A Telecommunications Network connection that accepts digitally encoded signals representing analogue voice transmissions or data transmissions. See also Network Port (Digital).

Note: Examples of digital network interfaces include, but are not limited to DSL, ISDN, 2.048 Mbit/s CAS or CCS, Ethernet, optical and digital wireless.

4.2.17 Direct Inwards System Access (DISA)

A method of providing direct caller access to CAE or private network equipment, after the Telecommunications Network call set up process has been completed. End to end address signalling is typically by use of in-band DTMF signals.

4.2.18 Dual Tone Multifrequency Signalling (DTMF)

A system for transmitting address and other information by superimposing a succession of voice frequency (VF) signals on a line.

Note: Each signal comprises two simultaneously transmitted tones of different frequency. Up to 16 different signals may be transmitted by standard DTMF signalling.

4.2.19 E & M Signalling

A signalling scheme by which DC line signals are transferred in each direction by application of an earth potential to an M lead, and reception of an Earth potential on the E lead. The E & M leads are separate from the voice path with which they are associated

4.2.20 Exchange line

See Network Port.

4.2.21 Extension line

See Local Port (On Premises).

4.2.22 External extension

See Local Port (Off Premises).

4.2.23 Functional Earth (FE)

The earthing point in equipment or in a system which is necessary for a purpose other than safety. A TRC is one form of a Functional Earth.

4.2.24 Hold

In relation to CE using loop-disconnect signalling, CE is considered to be in the Hold state at any time from application of loop until removal of loop provided that no other DC signalling activity is occurring.

4.2.25 Industry Based Proprietary Terminal (IBPT)

See System Integral Terminal.

4.2.26 Integrated Access Device (IAD)

A device that aggregates multiple channels, (voice or voice equivalent, with data), for transport to a telecommunications network via one or more transmission paths.

Note: IADs may use DSL, ATM, optical or other means of connection.

4.2.27 Local Port (Off Premises)

A port on a CAE that is capable of supporting terminating CE over a connecting link outside a building cabling environment; a carrier or carriage service provider may provide part of the link or it may be wholly provided by the customer.

Note 1: A local port may be directly provided by a CAE or indirectly by system integral equipment.

Note 2: Also see Table E1 in Appendix E for international port abbreviations.

- 4.2.28 Local Port (On Premises)
- A port on a CAE that is capable of supporting terminating CE over a connecting link within a building-cabling environment.
- Note 1: A local port may be directly provided by a CAE or indirectly by system integral equipment.
- Note 2: Also see Table E1 in Appendix E for international port abbreviations.
- 4.2.29 Network Port
- A port on a CAE that is capable of connection to a Telecommunications Network Service.
- Note: Also see Table E1 in Appendix E for international port abbreviations.
- 4.2.30 Network Port (Digital)
- A Network port where the voiceband information is presented as a digitally encoded bitstream. The physical realisation of a Network Port (Digital) can be DSL, ISDN, Ethernet, Wireless, Optical, but is not restricted to these.
- 4.2.31 Network Port (Four wire E&M)
- A Network Port for connection to a PSTN or CE that presents a 6-wire analogue interface. Four wires are used for the voice path. Two wires are used as separate E & M signalling leads.
- 4.2.32 Network Port (Indial)
- A Network Port with the ability to accept address signals from the PSTN/ISDN.
- 4.2.33 Network Port (Loop-in)
- A unidirectional call set-up port (set-up from the PSTN to a CAE) that is seized by application of a DC loop at the PSTN exchange.
- 4.2.34 Network Port (Ring-in/Loop-out)
- A bothway call set-up port. Incoming signalling to CE is by application of a ring signal at the PSTN exchange. Outgoing signalling from CE is by application of a DC loop at the CE.
- 4.2.35 Point of zero relative level (0 dBr point)
- A particular place within a transmission path chosen for reference and calculation purposes (also called the '0 dBr point'). ITU-T Recommendation G.223 [16] defines a 0 dBr point as a point where the long term average speech level per subscriber in an individual VF channel is -15 dBm.
- 4.2.36 Port
- An interface to equipment for the purpose of supplying an output signal and/or accepting an input signal.

- 4.2.37 Protective Earth (PE)
A connection to the Protective Earthing Conductor. Refer to AS/NZS 60950.1 [4].
- 4.2.38 Public Switched Telephone Network (PSTN)
That part of the Telecommunications Network which enables any customer to establish a connection for voice frequency communication with any other customer either automatically or with operator assistance.

Note: The PSTN has a nominal transmission bandwidth of 3 kHz.
- 4.2.39 Recall Backward
A signal which is sent in the backward direction after answer.

Note: This signal can only be used with the agreement of the parties providing the equipment at both ends of the circuit.
- 4.2.40 Recall Forward
A signal which is sent in the forward direction after the completion of information signalling.

Note: This signal can only be used with the agreement of the parties providing the equipment at both ends of the circuit.
- 4.2.41 Release Guard
A signal which is sent in the backward direction in response to the clear forward signal, and indicates that release of the equipment is in progress at the far end.
- 4.2.42 Reversal on Seizure
Reversal on Seizure is a facility available to some PSTN Network Ports that indicates the PSTN line state. It consists of a polarity reversal applied—

(a) in response to an applied loop for outgoing calls; and

(b) immediately prior to application of Ring for an incoming call.
- 4.2.43 Reversal On Answer
Reversal On Answer is a facility available to some PSTN Network Ports that indicates the B-Party state. It consists of a polarity reversal applied by the PSTN exchange to the A party line when the B-Party answers.
- 4.2.44 Ringer Equivalence Number (REN)
An approximate value of loading presented to the line during ringing state, and is based on the capacitance of a network port in the idle state. 1 REN is defined as 1 μ F in series with a 4 k Ω resistor.

- 4.2.45 Seize Acknowledge signal (Proceed to Send)
- A signal which is sent in the backward direction following the receipt of a seize signal and indicates that the equipment is ready to receive information signals.
- Note: The signal can only be used with the agreement of the parties providing the equipment at both ends of the circuit.
- 4.2.46 Seize signal
- A signal which is sent in the forward direction at the beginning of a call and prepares the equipment at the far end of the circuit to accept subsequent information and supervisory signals.
- 4.2.47 Standard telephone instrument
- CE, or part thereof, for analogue two-wire voice communication to which the requirements of AS/ACIF S002 [5] and AS/ACIF S004 [6] apply where both initiation and termination of the call is under user control.
- Note: Address signalling is provided by either loop-disconnect decadic signalling or by dual-tone multifrequency (DTMF) signalling, under direct user control or by user initiation of stored numbers.
- 4.2.48 System Integral Terminal
- Analogue or digital connected terminal, which is intended to operate in association with a CAE and functions as part of the CAE via a local port, for the purpose of voice telephony with the Telecommunications Network and may include both wired and wireless interfaces using proprietary or standards based signalling.
- The system integral telephony terminal (wired or wireless) is not intended for direct connection to a public network. Previously referred to as Industry Based Proprietary Terminal (IBPT)
- Note: Also see Table E1 in Appendix E for international port abbreviations.
- 4.2.49 Telecommunications Network
- Refer to Section 374(1) of the *Telecommunications Act 1997*.
- 4.2.50 Telecommunications Reference Conductor (TRC)
- A low noise earthing conductor, providing a zero voltage reference point for signalling and other functional purposes including, but not limited to, equipment reliability.
- Note: Integral surge suppression devices within Customer Equipment may be connected to the TRC.
- 4.2.51 Tie Line Port
- A Network Port for the interconnection of CAE.
- Note: Also see Table E1 in Appendix E for international port abbreviations.

4.2.52 Voice Frequency (VF)

Those frequencies in the range of 300 Hz to 3.4 kHz.

4.2.53 Voiceband

Voiceband is a general term that may include frequencies from 200 Hz to 4.0 kHz.

5 REQUIREMENTS

5.1 General

5.1.1 Power failure

In the event of power failure, such as caused by mains failure or discharge of back-up batteries, then the following apply:

- (a) For PSTN Network Ports (Ring-in/Loop-out)—
 - (i) the CE **shall not** seize the line to cause blocking; and
 - (ii) if a line is transferred to a Standard Telephone Instrument, on restoration of power, the CE should not release any connection established during the power fail period.
- (b) For PSTN Network Ports (Loop in) the battery feed **shall** be removed so that incoming traffic is not offered to the CE.
- (c) For PSTN Network Ports (Four wire E&M) the CE **shall not** seize the line to cause blocking.

Note: The PSTN will not be able to offer traffic to the CE as the M lead Wink will not be returned by the CE.

Compliance with Clause 5.1.1 should be checked by inspection or operation as appropriate.

5.1.2 Network Port calls

An incoming call from the telecommunication network (including those switched via a private network) **shall** only be lost if—

- (a) the call is unanswered and then abandoned by the calling party;
- (b) the call is forcibly released by the operation of a key at the operator's position; or
- (c) the call is force released by the PSTN or ISDN.

Compliance with Clause 5.1.2 should be checked by inspection or operation as appropriate.

5.1.3 Functional Earth connection and Protective Earth connection

5.1.3.1 Form of Functional earth

If Customer Equipment has an earth dependent DC signalling component or a requirement for a low noise earth then a FE should take the form of either—

- (a) a TRC; or
- (b) an ELV DC power source that complies with AS/NZS 3015 [3]; or

- (c) a DC positive return circuit which obtains a connection to earth through a common power supply earthing point.

5.1.3.2 Functional earth requirements

The following requirements apply for the connection of CE to the FE.

- (a) Where CE has PSTN Network Ports (Loop-in), the positive pole of the power supply providing the battery feed potential for loop-in PSTN lines **shall** be connected to the FE.

Note: Loop-in PSTN line is described in AS/ACIF S002 [5].

- (b) Where CE has E &M signalling capability, the positive pole of the power supply providing the signalling source **shall** be connected to the FE.

Note: E & M signalling is described in Clause 5.6 and Appendix A.

Compliance with Clause 5.1.3.2 should be checked by inspection.

5.1.3.3 Local Port Functional earth

For Local Port (Off Premises) as described in Clause 5.3, the CE should have the FE connected to the positive pole of the power supply providing the battery feed potential.

Note: This is to minimise noise and facilitate carrier or carriage service provider operations and maintenance activities.

5.1.3.4 Functional Earth connection

Where CE requires an earth connection for functional purposes and the CE incorporates a mix of port types (e.g. local, network, data, etc) connection to the external functional earthing system—

- (a) **shall** be by a designated screw terminal or equivalent method; and
- (b) **shall not** rely on the use of a pluggable mains protective earth for this purpose.

5.1.3.5 Linking to Protective earth

Where a hard-wired PE is connected to the CE, the optional linking of PE and FE terminals within the CE is allowed. The following requirements apply:

- (a) Where the linking of PE and FE terminals is factory fitted or intended to be performed by installation personnel, the installation manual/instructions or other supporting documentation **shall** indicate—
 - (i) the methods by which installation personnel are to install and/or remove the link;
 - (ii) the methods by which installation personnel are to connect the PE and/or FE to the CE;

- (iii) that a FE conductor cannot be connected if the link is installed between PE and FE terminals within the CE; and
 - (iv) that the link between PE and FE terminals must not be installed within the CE if a FE conductor is connected.
- (b) Where an intrinsic bond exists between PE and FE within the CE, the installation manual/instructions or other supporting documentation **shall** indicate—
- (i) the methods by which installation personnel are to connect the PE to the CE; and
 - (ii) that a FE conductor must not be connected to the CE.

Compliance with Clause 5.1.3.5 should be checked by inspection of the relevant installation documentation.

5.1.3.6 Protective earth isolation link

The requirements of AS/NZS 60950.1 [4] are to apply to the isolation between the FE and PE terminals within a CE with any links as described in Clause 5.1.3.5 removed.

Compliance with Clause 5.1.3.6 should be checked in accordance with the requirements of AS/NZS 60950.1 [4].

5.1.4 Emergency services access

5.1.4.1 Support of emergency services access numbers.

When each of the following emergency services access numbers is dialled, all CE **shall** provide a full duplex speech path within 1 s of the last digit being forwarded to a Telecommunications Network:

- (a) 000 (three digits).
- (b) 106 (three digits).

Note: Where a private network is used to provide access to an emergency service, the private network operator should ensure that the accessed network port (and hence the CLI that is passed to an emergency service organisation in conjunction with other location information is used to determine the location of the emergency caller) is placed as close as possible to the user of the private network port.

5.1.4.2 Access barring of emergency service numbers.

CE should not support access barring of emergency service numbers.

5.1.4.3 Support following the loss of mains power

Mains-powered CE should continue to support the dialling of emergency service numbers for at least 30 minutes following the loss of mains power.

Note: CE that does not continue to support emergency dialling after loss of mains power, should include in the accompanying documentation a warning notice. A suggested wording for such a warning notice is as follows:

Warning

This equipment will be inoperable when mains power fails

Compliance with Clause 5.1.4 should be checked by inspection.

5.1.5 Security of dialled information

To assist in safeguarding the security of dialled information stored or processed within a CE or output to any subsequent call detail processing system, CE which incorporates the facility for recording or outputting of digits dialled on outgoing Public Network calls should provide the capability to truncate the digit information. Where a truncation capability is provided, the extent of truncation should be configurable within a CE.

Note 1: The following is a possible example of achieving this:

- (a) All Local Telecommunications Network codes – not more than six leading digits to be available.
- (b) All National Telecommunications Network codes – not more than eight leading digits to be available.
- (c) All International Telecommunications Network codes – not more than sixteen leading digits to be available.

Note 2: Local telecommunications network codes may be determined from the ACMA numbering plan.

Note 3: 'Leading' digits exclude the Telecommunications Network exchange access codes used by the CE, e.g. '0'.

5.1.6 Security of incoming automatically answered calls

Where a CE provides for DISA facility and it is used to access other Network Ports and/or private network features, it is strongly recommended that an authorisation procedure be invoked (e.g. Personal Identification Number (PIN) with a suitable number of digits) to enable access.

The CE user documentation should include information warning that the DISA facility could be subject to fraudulent use if adequate security measures are not in place.

Compliance with Clause 5.1.6 should be checked by inspection.

5.1.7 Indial requirements for CE

The following requirements apply to CE with PSTN or ISDN indial capability, or both:

- (a) PSTN Network Port (Indial)

For CE that has a PSTN indial capability, the requirements of AS/ACIF S002 [5] apply for both loop-in PSTN interface and 2048 kbit/s interface - CAS protocol.

(b) ISDN Network Port (Indial)

For CE that has an ISDN indial capability, the following Call Control requirements apply, as detailed in AS/ACIF S031 [8] or AS/ACIF S038 [9], as appropriate to the interface type used.

- (i) If the addressed user is classified as denied, unallotted or unequipped, the CE **shall** return Cause Code 1 (Unallocated /Unassigned Number) as part of a clearing message where the call is not diverted to an operator or a RVA.
- (ii) If the addressed user is diverted to an operator or RVA, any through connection of the speech path **shall** be preceded by a Connect message.
- (iii) If the addressed user is free, for a 3.1 kHz Audio Bearer Service or Speech call, the CE **shall**—
 - (A) return an Alerting message; or
 - (B) return a Progress message, if the Telecommunications Network supports the option to through switch the transmission path prior to call acceptance.

Note 1: An Alerting message will enable the Telecommunications Network to apply Ring Tone to the caller where applicable.

Note 2: A CE should not return a clearing message after this Alerting Message unless it is either preceded by a clearing message from the Telecommunications Network or as a consequence of error procedures detailed in ACA Technical Standard 014 [1] and AS/ACIF S031 [8] and AS/ACIF S038 [9].

- (iv) If the addressed user is busy, the CE **shall** return Cause Code 17 (User Busy) as part of a clearing message where the call is not diverted to an operator or RVA.

Compliance with Clause 5.1.7 should be checked by operation.

5.2 Network Ports (Ring-in/Loop-out)

5.2.1 General

5.2.1.1 Network Port requirements

Clause 5.2 specifies the requirements for analogue two-wire Network Ports (Ring in/Loop-out). The requirements for Network Ports (Four wire E&M) are specified in Appendix A. The requirements for two-wire Network Ports (Loop-in - Indial) are specified in AS/ACIF S002 [5].

5.2.1.2 S002 requirements

The CE is to comply with the analogue interworking and non-interference requirements of AS/ACIF S002 [5] unless stated otherwise in this Standard.

5.2.1.3 Idle state blocking

While the Network Port is in the idle state, an incoming call **shall not** be blocked.

Compliance with Clause 5.2.1.3 should be checked by operation.

5.2.2 Common requirements

The following requirements apply to each Network Port (Ring-in/Loop-out) of the CE.

5.2.2.1 Line polarity

The operation of the Network Port **shall** be independent of line conductor polarity except where polarity dependent line signals need to be detected. If the CE is polarity dependent because it needs to detect line signals (those associated with incoming and outgoing calls), then the CE should incorporate long term polarity independence while still being able to detect the short term signals present during calls.

Note 1: The polarity of a line may not be guaranteed by carriers or carriage service providers.

Note 2: Polarity dependent line signals include reversal-on-seizure and reversal on answer signals.

Compliance with Clause 5.2.2.1 should be checked by application of polarity reversals.

5.2.2.2 Release blocking

The Network Port **shall** be blocked to further outgoing calls for not less than 800 ms after the release of an outgoing call.

Compliance with Clause 5.2.2.2 should be checked by using the test set up as indicated in Clause 6.6.2.

5.2.2.3 Idle resistance

The following requirements are applicable to the CE in the off-line state:

- (a) The insulation resistance **shall not** be less than 1 M Ω between—
 - (i) the two line conductors;
 - (ii) each line conductor and FE terminal if equipped; and
 - (iii) each line conductor and PE terminal, if equipped

when tested with 250 V d.c. of either polarity, in series with a 600 k Ω resistor. Any internal protective devices remain connected during this test.

- (b) The idle insulation resistance of the Network Port **shall not** be less than 200 k Ω at 100 V d.c. when one or both of the following facilities are provided:
 - (i) Reversal-on-Seizure detection, as described in Clause 5.2.2.5.
 - (ii) Automatic Guard, as described in Clause 5.2.2.6.

5.2.2.4 Line leakage resistance

A CE Network Port **shall** continue to operate with a 50 k Ω resistance across the network port terminals or from either network port terminal to ground.

Compliance with Clause 5.2.2.4 should be checked by using the test set up as indicated in Clause 6.6.4.

5.2.2.5 Reversal on Seizure

Reversal on Seizure may be used by a public network to indicate to the CE the cessation of an incoming or an outgoing call. Its availability is subject to negotiation with the carrier or carriage service provider concerned. Incorporation of this facility is optional, but where it is incorporated the CE Network Port **shall**—

- (a) recognise a polarity reversal for a duration of 200 ms and greater as a seizure condition; and
- (b) recognise application of normal polarity for a duration of 200 ms and greater as an idle or line-lockout condition.

Note 1: Reversal on Seizure is achieved by the PSTN exchange applying a normal polarity to the line wires during the idle and line-lockout states. When an outgoing (loop) or incoming (ring) seizure occurs, the line polarity is reversed. Table 1 details the line wire conditions.

Note 2: For Reversal on Seizure, the only Proceed to Send indication for outgoing calls from the CE is receipt of PSTN dial tone. The application by the PSTN exchange of a polarity reversal, after application by the CE of an outgoing Loop, does not constitute a Proceed to Send indication.

Compliance with Clause 5.2.2.5 should be checked by using the test set up indicated in Clause 6.6.1.

Table 1
Line Polarity for Reversal-on-Seizure

State	Normal Bothway line		Bothway line with Reversal-on-Seizure	
	L +	L –	L +	L –
Idle	+ve	–ve	+ve	–ve
Outgoing Loop	+ve	–ve	–ve	+ve
Incoming Ring	+ve	–ve	–ve	+ve
Line-Lockout	+ve	–ve	+ve	–ve

5.2.2.6 Automatic Guard

The following requirements apply to CE that provides Automatic Guard:

- (a) CE **shall** detect one or more of the following:
- (i) The absence of exchange service tones, as specified in Appendix B of AS/ACIF S002 [5] at outgoing seizure.
 - (ii) An open circuit on one or both of the network port terminals.
 - (iii) An idle line voltage of less than 40 V d.c.

On detection of any of the above, the CE **shall** block the port to outgoing traffic. This blocking is to be effective only during the period of the fault condition, and should operate a suitable indicator or alarm.

Note 1: In the case of Clause 5.2.2.6(a) (iii), it should be possible to disable this feature, if implemented, on a per Network Port basis.

Note 2: CE voltage detection should not be reliant on the feedbridge within the carrier /CSP network being earth referenced.

- (b) CE may be able to automatically detect that a fault on a PSTN line has been corrected. Where a CE provides this capability through the automatic seizure of PSTN lines, such automatic seizures should not be repeated at intervals of less than 60 s on any individual line.

If a CE detects that a PSTN line has been returned to service, the CE **shall** unblock the Network Port.

Note: The CE may detect that the line has been restored to service by a successful seizure, or an incoming call, or the detection of feed restoration utilising Clauses 5.2.2.6(a) (ii) and/or 5.2.2.6(a) (iii).

Compliance with Clause 5.2.2.6 should be checked by using the test set up as indicated in Clause 6.6.3.

5.2.2.7 Proceed-To-Send – Wink Start (Loop-out calls)

When a CE has the capability to receive a Wink Start, it **shall** recognise a Line Polarity Wink (fleeting reversal) in the range 135 ms to 165 ms inclusive occurring 90 ms and later after the CE has applied a loop.

Note: The availability of this proceed-to-send signal, in lieu of dial tone, is subject to negotiation with the carrier or carriage service provider concerned.

Compliance with Clause 5.2.2.7 should be checked by operation.

5.2.2.8 Reversal on Answer

Where Reversal on Answer detection capability is provided, the CE **shall** be ready to receive the reversal within 90 ms of the transmission of the last digit. Table 2 details the line wire conditions

Table 2
Line Polarity for Reversal-on-Answer

State	Normal Bothway Line		Bothway Line with Reversal on Answer	
	L+	L-	L+	L-
Idle	+ve	-ve	+ve	-ve
Outgoing Loop	+ve	-ve	+ve	-ve
B-party Answer	+ve	-ve	-ve	+ve
Incoming Ring	+ve	-ve	+ve	-ve
Incoming Answer	+ve	-ve	+ve	-ve
Line Lockout	+ve	-ve	+ve	-ve

Note 1: This facility may not be available for all types of outgoing lines provided by carriers or carriage service providers.

Note 2: The line polarity is restored to the pre-answer state, depending on the particular carriage service provider line being directly interfaced to the CE, by any of the following:

- (a) On clearing by the A-party.
- (b) On clearing by the B-party.
- (c) By PSTN timeout after B-party clearing.

Compliance with Clause 5.2.2.8 should be checked by operation.

5.2.3 Automatic bothway operation

5.2.3.1 General

Clauses 5.2.3.2 and 5.2.3.3 apply, in addition to the requirements for incoming or outgoing operation, to bothway operation of CE that—

- (a) access the PSTN by automatic selection of a Network Port from a group of two or more ports for the purposes of making an outgoing call; and
- (b) do not provide, within 2 s of PSTN line seizure, a full duplex speech path between a Local Port making an outgoing call and the selected Network Port.

5.2.3.2 Call collision – outgoing

CE is to prevent the connection of an automatically selected outgoing call to a Network Port that is held by an earlier incoming call by use of one of the following methods:

- (a) Both of the following:
 - (i) Blocking Network Ports to outgoing calls after the release of an incoming call at the CE end. The blocking period **shall** normally be set at 10 s and should be adjustable from 5 to 16 s.
 - (ii) If a Call Still Held (CSH) situation arises (i.e. when the incoming call is held by the originating party for longer than the blocking period described in item (i)), the CE should block the port to outgoing calls for a period of not less than 140 s. Incoming ring during this CSH period **shall** be detected and the CSH period terminated. The detection of a busy tone may also be used to terminate the CSH period.

Note: The PSTN will force release the incoming call within 140 s of the CE Clear Back signal being detected but will restart its supervision period if a seizure signal is detected.

- (b) The use of the Reversal on Seizure facility, as specified in Clause 5.2.2.5, that is available at some PSTN exchanges.
- (c) A method other than those specified in Items (a) to (b) such that the number of outgoing calls lost **shall not** be more than 1 in every 1000.

Compliance with Clause 5.2.3.2(a) should be checked by using the test set up as indicated in Clause 6.6.2.

Compliance with Clause 5.2.3.2(c) may need to be supported by the results from statistical analysis, simulation and/or in-service trial.

5.2.3.3 Early Guard – incoming

5.2.3.3.1 Incoming line seizure

The following signals are applied by the PSTN as incoming line seizure:

- (a) Ring as specified in AS/ACIF S002 [5].
- (b) Reversal of line polarity for duration of 200 ms and greater.

5.2.3.3.2 Incoming seizure blocking

Except where provided for in Clause 5.2.3.3.3, the CAE Network Port **shall** be blocked to outgoing calls within 200 ms of commencement of the incoming line seizure signal (ring or polarity reversal) from the exchange.

5.2.3.3.3 Simultaneous seizure

In the event of the detection of the seizure signal from the Telecommunications Network exchange simultaneously with the seizure of the port by an outgoing call from the CAE, the incoming call **shall** take precedence and be processed in the normal manner.

Note 1: If the seizure signal is indicated by reversal, the CAE may unblock the port to outgoing calls if feed polarity is restored before the incidence of ring signal.

Note 2: If the seizure signal is not followed by a ring signal for a period longer than the maximum silent period of ring signal cadence, the CAE may unblock the port for outgoing calls.

Compliance with Clause 5.2.3.3 should be checked by using the test set up as indicated in Clause 6.6.1.

5.3 Standard analogue telephone Local Port (On Premises and Off Premises)

5.3.1 General

5.3.1.1 Applicability of section 5.3

If the CE has provision for the connection of other CE (Ring in/Loop out) compliant with AS/ACIF S002 [5], then the signalling requirements of Clause 5.3 are to apply.

A Local Port that is not compliant with the requirements of Clause 5.3 is unsuitable for connection of AS/ACIF S002 [5] compliant CE. User documentation **shall** clearly describe this limitation.

It may however, be considered proprietary (i.e. only intended for the connection of analogue system integral equipment). The combined CAE with analogue system integral equipment is regarded as a single CE and is to comply with the requirements of Clause 5.4.

Compliance with Clause 5.3.1 should be checked by inspection of documentation.

5.3.2 Line signals

5.3.2.1 Ring signal

The following requirements apply for the Ring Signal:

- (a) The frequency **shall** be in the range of 16 Hz to 55 Hz.
- (b) The noise level **shall not** exceed 774 mV psophometric for all loadings of the ring signal source.

- (c) The level **shall** be sufficient to produce a minimum ring voltage of 50 V r.m.s. across the line termination of 1 μ F in series with a 4 k Ω resistor (i.e. 1 REN) for;
 - (i) Local Port (On Premises), in the configuration of Figure 13(a);
 - (ii) Local Port (Off Premises) in the configuration of Figure 13(b).
- (d) The DC voltage feed should be maintained both during the application of ring current and during the silent period.

Note 1: The recommended frequency is 25 Hz.

Note 2: The noise level requirement does not apply where building cabling and/or the Telecommunications Network is not intended to be used for the distribution of Local Ports.

Note 3: The cadence of the ring signal should be such that the silent period of the ring is less than 2.5 s. This is because AS/ACIF S002 compliant automatic answering CE may interpret the call as abandoned if the silent period exceeds this duration.

Note 4: Ring signals of frequencies greater than 28 Hz may not be supported by a carrier or carriage service provider for Local Port (Off Premises).

Compliance with Clause 5.3.2.1 should be checked by using the test set up as indicated in Clause 6.6.5.

5.3.2.2 Answer/Seizure/Hold signals

The Local Port **shall** meet the following:

- (a) For Local Port (On Premises)—
 - (i) recognise within 300 ms as an answer/seizure/hold signal, the application of a resistive termination of up to 600 Ω (recommended up to 1200 Ω); and
 - (ii) provide a minimum battery feed current of 18 mA over the entire range of hold signals.
- (b) For Local Port (Off Premises)—
 - (i) recognise within 300 ms as an answer/seizure/hold signal, the application of a resistive termination of up to 1800 Ω ; and
 - (ii) provide a minimum battery feed current of 18 mA over the entire range of hold signals; and
 - (iii) provision of an Off Premises Local Port capability **shall not** rely on equipment being located on the carrier or carriage service provider side of the network boundary, for example remote ring generators, signalling loop extenders.

- (c) If CE has both On Premises and Off Premises Local Ports, together the two Local Ports **shall** cover the whole range of loop conditions up to 1800 Ω .

Note 1: The loop resistance of 600 Ω and 1800 Ω comprises the sum of telephone and associated cabling resistance.

Note 2: CE may provide a local port covering both On Premises and Off Premises requirements which must recognise terminations from 0 Ω to 1800 Ω .

Note 3: An open circuit voltage of 42 V d.c. minimum is recommended for Off Premises Local Ports. Any voltage less than 42 V d.c. may not be supported by the carrier or carriage service provider.

Compliance with Clause 5.3.2.2 should be checked by using the test set up as indicated in Clause 6.6.6 and 6.6.10.

5.3.2.3 Idle/Release signals

The Local Port **shall** recognise a resistive termination of 10 k Ω and greater as an idle/release signal.

Compliance with Clause 5.3.2.3 should be checked by using the test set up as indicated in Clause 6.6.7.

5.3.2.4 Recall signal

If the CE is to recognise timed loop break signals as specified in AS/ACIF S002 [5], then the receive limits should be 40 ms to 140 ms.

Compliance with Clause 5.3.2.4 should be checked by using the test set up as indicated in Clause 6.6.11.

5.3.3 Address signals

5.3.3.1 Decadic signals

If decadic (loop disconnect) signal detection is provided, the following requirements are to apply:

- (a) Break and Make signals that are within the following limits **shall** be recognised:

Break pulse: 50 ms to 76 ms

Make pulse: 28 ms to 46 ms

- (b) A make period of 350 ms and greater **shall** be recognised as an interdigital pause.

- (c) Make and Break pulses of 5 ms or less should be rejected.

Compliance with Clause 5.3.3.1 should be checked by using the test set up as indicated in Clause 6.6.8.

5.3.3.2 DTMF signals

If DTMF signal detection is provided, the following requirements are to apply:

- (a) DTMF signals that are within the following limits **shall** be recognised:
 - (i) Frequency tolerances of $\pm(1.5\% + 2 \text{ Hz})$ from the nominal frequency as specified in AS/ACIF S002 [5].
 - (ii) A total RMS power level between 0 dBm and -20 dBm with a maximum difference between the high frequency tone and the low frequency tone power of $+4$ dB to -4 dB relative to that of the low frequency tone.
 - (iii) A break between tone signals of 70 ms and greater, as an interdigital pause.
 - (iv) A valid tone signal of 40 ms duration and greater.
- (b) The following DTMF signals **shall** be rejected:
 - (i) A tone signal of 20 ms duration and less.
 - (ii) A tone signal of -40 dBm and less.
 - (iii) A tone signal with a deviation of either frequency of greater than or equal to $\pm 3.5\%$ from the nominal frequency as specified in AS/ACIF S002 [5].
 - (iv) A break between two consecutive and identical tone signals of less than 15 ms as an interdigital pause.

Compliance with Clause 5.3.3.2 should be checked by using the test set up as indicated in Clause 6.6.9.

5.4 System Integral Terminals

The following requirements apply to CAE which provide the capability to connect System Integral Terminals (SITs) (such as system integral telephones and operator console instruments) for the purpose of voice telephony with the Telecommunications Network.

The combined CAE with the SIT is regarded as CE for purposes of testing voice telephony.

5.4.1 Voice Frequency Performance

CAE in combination with a SIT is to comply with the applicable requirements of AS/ACIF S004 [6] when measured at all supported network port types.

Note: The voice frequency performance of a connection involving SIT and a digital network port is defined with respect to the analogue port of a test codec or a digital equivalent, complying with ITU-T Recommendation G.711 [18] A-law at the digital access point.

5.4.2 Signal levels

- (a) A SIT that is for use only within a building cabling environment, using a shared cable, **shall** comply with the signal characteristics specified in Appendix C unless its use is restricted to pairs of a separate dedicated cable.

Note: Compliance with these requirements does not guarantee compatibility with all the public network schemes in use, but reduces the likelihood of interference with these. In cases where compatibility issues arise, the SIT cabling is to be provided separate from the cable carrying public network services.

- (b) Where a separate dedicated cable is required, this **shall** be clearly stated in the installation documentation.
- (c) A SIT for use over a connecting link where a carrier or carriage service provider may provide part or all of the link is to comply with the requirements of AS/ACIF S043.2 [12] or AS/ACIF S043.3 [13] as appropriate.

5.4.3 Balance about earth

The analogue Network Ports of a CE **shall** have an impedance balance as specified in Clause 5.5.1.4(a) when a connection is established through the CE to the SIT.

5.4.4 Return loss

The analogue Network Ports of a CE **shall** have return loss values that meet the mask requirements specified in ETSI ES 201 168 [23] when a call connection is established through the CE to an SIT, measured using a TN12 reference impedance, see Figure 2.

Compliance with Clause 5.4 should be checked by inspection or testing as appropriate.

5.5 Transmission requirements

5.5.1 General

5.5.1.1 DC test current

For all analogue ports, the DC current for testing purposes **shall** be determined by the range of terminations shown in Table 3.

5.5.1.2 Return Loss measurements

CE **shall** provide Return Loss, and Terminal Balance Return Loss (TBRL) values meeting the requirements of the masks specified in Figures 5 and 13 of ETSI ES 201 168 [23] when measured using a TN12 reference impedance, see Figure 2. CE port impedances are specified in Table 4.

Table 3
DC terminations

Analogue port type	External resistance (Ω)	External voltage (V)
Local Port (On Premises)	300 to 600 (Note)	Not applicable
Local Port (Off Premises)	300 to 1800 (Note)	Not applicable
Network Port (Ring-in/Loop-out)	400 to 2300	44 to 56
Network Port (Loop-in)	300 to 2500	Not applicable
Network Port (Four-wire E&M)	300 to 2500	44 to 56

Note: Local Ports are to comply with the requirements of Clause 5.3.

Table 4
Port and balance network impedances

Port type	Input impedance [Z_{in}]	Balance impedance [Z_B]
Local Port (On Premises) or (Off Premises)	$Z_1 = 220 \Omega + (820 \Omega // 120 \text{ nF})$ $= 600 \Omega$ (Note)	$Z_2 = 220 \Omega + (820 \Omega // 120 \text{ nF})$ $= 600 \Omega$ (Note)
Two-wire Network Port	$Z_3 = 220 \Omega + (820 \Omega // 120 \text{ nF})$ $= 600 \Omega$ (Note)	$Z_4 = 220 \Omega + (820 \Omega // 120 \text{ nF})$ $= 600 \Omega$ (Note)
Four-wire Network Port	$= 600 \Omega$	Not applicable

Note: Complex impedances (i.e. 220Ω in series with $820 \Omega // 120 \text{ nF}$) are mandatory on Local and 2 wire Network ports, however, a complex impedance [Z] using 115 nF may be used, providing all relevant transmission path requirements are satisfied. To improve matching and the four-wire loop loss when the ports are connected to a 600Ω device/service, a 600Ω impedance is recommended as a strappable/switchable option.

5.5.1.3 Power Spectral Density Requirements for analogue Local and Network Ports

This Clause is applicable to Local Port (On Premises and Off Premises) or Network Port E&M. The PSD requirements for Network Ports (Ring-in/Loop-out) are contained in AS/ACIF S002 [5].

The noise requirements of this Clause apply during all idle and active Port states. The active Port states include Seize, Dialling, Ringing and Release/Cleardown.

For a Local Port or a Network Port E&M:

- (a) The Power Spectral Density (PSD) of signals beyond 3.4 kHz **shall not** exceed the limit shown in Figure 1 when measured using a noise power bandwidth of 10 kHz.
- (b) The PSD of signals between 300 kHz and 30.175 MHz **shall** be either less than -120 dBm/Hz; or more than 10 dB below the PSD limit shown in Figure 1 (represented by the dashed line). when measured as the total average power within a 1 MHz sliding window (1 MHz bandwidth) which is described in Table 5.

Note: The Power Spectral Density (PSD) requirements do not apply where building cabling and/or the Telecommunications Network is not intended to be used for the distribution of Local Ports.

Table 5
PSD within a 1 MHz sliding window

Parameter	Value
Bandwidth of sliding window	1 MHz
Reference frequency	Lower edge
Step size	10 kHz
Start frequency	300 kHz
Stop frequency	29.175 MHz

Note 1: The Power Spectral Density requirements contained in Clause 5.5.1.3 are the same as in ANSI Standard T1.601 [14], and have been included to ensure spectral compatibility of CE with DSL CE.

Note 2: The purpose of the sliding window measurement is to ensure that CE does not generate noise up to the allowable limit across the entire band.

Compliance with Clause 5.5.1.3 should be checked by using the test set up as indicated in Clause 6.6.13.

5.5.1.4 Balance about earth

The following measurements are to be made in conformance with ITU-T Recommendation O.9 [20] to assess the degree of unbalance about earth.

- (a) Longitudinal Conversion Loss (LCL)

The LCL **shall** be greater than 46 dB for both two-wire and four wire ports. To minimise interference from low frequency induction and electrical traction systems, the following values are recommended:

Local Port (Off Premises) 52 dB

Network Port 52 dB

LCL is defined as the ratio of the input transverse voltage arising from a balanced input longitudinal voltage of 3.0 V r.m.s, in the frequency range 50 Hz to 3400 Hz, applied between earth and the midpoint of two 0.1%, 300 Ω resistors connected in series across the input terminals of the test point, to the input longitudinal voltage.

(b) Longitudinal Conversion Transfer Loss (LCTL)

The LCTL should be greater than 52 dB for both two-wire and four wire ports.

LCTL is defined as the ratio of the output transverse voltage arising from a balanced input longitudinal voltage of 3.0 V r.m.s., in the frequency range 50 Hz to 3400 Hz, applied between earth and the midpoint of two 0.1%, 300 Ω resistors connected in series across the input terminals of the test point, to the input longitudinal voltage.

(c) Transverse Conversion Loss (TCL)

The TCL should be greater than 46 dB for both two-wire and four wire ports.

TCL is defined as the ratio of the input longitudinal voltage arising from a balanced input transverse voltage of -10 dBm₀, in the frequency range 50 Hz to 3400 Hz, applied across the input terminals of the test point, to the input transverse voltage.

(d) Transverse Conversion Transfer Loss (TCTL)

The TCTL should be greater than 46 dB for both two-wire and four wire ports.

TCTL is defined as the ratio of the output longitudinal voltage arising from a balanced input transverse voltage of -10 dBm₀, in the frequency range 50 Hz to 3400 Hz, applied across the input terminals of the test point, to the input transverse voltage.

Compliance with Clause 5.5.1.4 should be checked by using the transmission test set up as indicated in Clause 6.6.12.

5.6 Analogue Tie Line Network Ports

5.6.1 C2 Series signals

C2 Series E & M Lead Signals are intended for use with four-wire voice services utilising separate E & M connections. Earth-off-idle signalling is the recommended method. Figure 3 shows the line signalling protocol. If the CE provides C2 Series signalling capability then the following requirements apply.

Note 1: The transfer of information by means other than DC, such as VF signals, may be used where there is agreement between the parties providing the CE at each end of the Tie Line.

Note 2: Carriers may not support Earth-on-Idle signalling

5.6.1.1 Electrical interface

CE is to comply with the electrical interface requirements of Appendix A.

5.6.1.2 Signalling codes (Earth-on-Idle)

Table 6 specifies the C2 Series signalling codes (Earth-on-Idle).

Table 6
C2 Series signalling codes (Earth-on-Idle)

Signal/State	Direction	Code
Idle	Forward	Earth applied
	Backward	Earth applied
Seize	Forward	Removal of earth
Seize Acknowledge (optional)	Backward	Removal of earth (timed)
Answer	Backward	Removal of earth
Clear Back	Backward	Restoration of earth
Recall Forward (optional)	Forward	Restoration of earth (timed)
Recall Backward (optional)	Backward	Restoration of earth (timed)
Decadic Pulsing	Forward	Restoration of earth (pulsed)
Clear Forward	Forward	Restoration of earth
Release Guard	Backward	Restoration of earth
Blocking (optional)	Backward	Removal of earth (timed or continuous)

5.6.1.3 Signalling codes (Earth-off-Idle)

Table 7 specifies the C2 Series signalling codes (Earth-off-Idle).

Table 7
C2 Series signalling codes (Earth-off-Idle)

Signal/State	Direction	Code
Idle	Forward	Earth removed
	Backward	Earth removed
Seize	Forward	Application of earth
Seize Acknowledge (optional)	Backward	Application of earth (timed)
Answer	Backward	Application of earth
Clear Back	Backward	Removal of earth
Recall Forward (optional)	Forward	Removal of earth (timed)
Recall Backward (optional)	Backward	Removal of earth (timed)
Decadic Pulsing	Forward	Removal of earth (pulsed)
Clear Forward	Forward	Removal of earth
Release Guard	Backward	Removal of earth
Blocking (optional)	Backward	Restoration of earth (timed or continuous)

5.6.2 Line signalling tolerances

The following requirements apply to C2 Series signals, as described in Clause 5.6.1.

5.6.2.1 Signal sending

The line signal duration **shall** be within the ranges specified in Table 8.

Table 8
Sending tolerances

Signal	Duration (ms)	Remarks
Seize Acknowledge	110 to 130	Optional
Clear Back	110 and greater	
Answer	110 and greater	
Recall Backward	60 to 80	Optional
Recall Forward	60 to 80	Optional
Clear Forward	480 and greater	
Blocking	110 to 130	Optional
Decadic Make	30 to 40	
Decadic Break	60 to 70	

5.6.2.2 Signal recognition

5.6.2.2.1 The Tie Line ports should recognise signals with the timings specified in Table 9.

Table 9
Receiving tolerances

Signal	Duration (ms)	Remarks
Seize	150 and greater	
Seize Acknowledge	100 to 140	Optional
Answer	40 and greater	
Clear Back	100 and greater	
Clear Forward	240 and greater	
Blocking	100 to 140	Optional
Recall	50 to 90	
Decadic Make	20 to 70	
Decadic Break	28 to 90	

5.6.2.2.2 Interruptions of less than 10 ms to any signal should be ignored. Interruptions of more than 20 ms should cause the timing of the signal recognition to restart except in the case of Decadic Make and Break signals.

5.6.2.3 Repetition of Line Signals

Where it is necessary for a CE to repeat line signals, the outgoing signal should be corrected to conform to the sending limits above.

5.7 Digital Tie Line Ports

5.7.1 General

This section specifies the requirements for digital Tie Line Ports at the CE. CE intended for connection to a 2048 kbit/s telecommunications service is to comply with the applicable requirements AS/ACIF S016 [7].

5.7.2 n x 64 kbit/s service

The CE may interface to the 2048 kbit/s telecommunications service using n times 64 kbit/s timeslots, for $1 \leq n \leq 30$. Where this service is used, the CE interface is to comply with the following requirements:

- (a) The interface **shall** conform to the framing format specified in ITU-T Recommendation G.704 [17] § 5.1.
- (b) Channel Associated Signalling (CAS), conforming to ITU-T Recommendation G.704 [17], § 5.1.3.2, may be used. Where CAS is used, the signalling sense **shall** be positive (this means when the M-Lead is grounded, the corresponding bit is set to zero).
- (c) The CE may use the carrier or carriage service provider to process encoded voice frequency signals (0.3 to 3.4 kHz). Where processing is performed, such signals **shall** be A-law PCM encoded to ITU-T Recommendation G.711 [18].

Note: An example of processing is the provision of echo cancelling facilities by the carrier or carriage service provider.

Compliance with Clause 5.7.2 should be checked by operation.

5.8 Digital PSTN Network Ports

5.8.1 General

This section specifies the requirements for digital PSTN Network Ports at the CE. CE intended for connection to a 2048 kbit/s telecommunications service is to comply with the applicable requirements of AS/ACIF S016 [7].

Note: The 2048 kbit/s service allows the replacement of up to 30 analogue ports between an exchange and the CE with a single digital link. The exchange service is the replacement of n analogue ports with a digital link of n times 64 kbit/s channels, thus providing a complete digital path from the exchange to the Customer Equipment. The normal analogue in-band features are available with the line signalling transmitted using CAS.

5.8.2 n x 64 kbit/s service

5.8.2.1 Framing format

Where this service is used, the CE is to comply with the following requirements:

- (a) The interface **shall** conform to the framing format specified in ITU-T Recommendation G.704 [17] § 5.1.
- (b) The multiframe format as specified in ITU-T Recommendation G.704 [17] § 5.1.3.2. The signalling sense **shall** be positive (this means that when the M-Lead is grounded, the corresponding bit is set to zero).

Compliance with Clause 5.8.2.1 should be checked by operation.

5.8.2.2 PCM encoding

Voice frequency signals (0.3 to 3.4 kHz) **shall** be A-Law PCM encoded as specified in ITU-T Recommendation G.711 [18].

The signalling requirements for the CAS scheme are to comply with Appendix B.

Compliance with Clause 5.8.2.2 should be checked by operation.

5.8.3 Emergency services access

The CE **shall** comply with the requirements of Clause 5.1.4.

Compliance with Clause 5.8.3 should be checked by inspection.

5.8.4 Security of dialled information

The CE should comply with the requirements of Clause 5.1.5.

5.8.5 Security of incoming automatically answered calls

The CE should comply with the requirements of Clause 5.1.6.

5.8.6 Automatic bothway operation

The CAE **shall** comply with the requirements as detailed in Clauses 5.2.3.2(a) and (b).

Compliance with Clause 5.8.6 should be checked by operation.

5.8.7 Automatic answering of incoming calls

- (a) The CE is to comply with the requirements of AS/ACIF S002 [5] for Automatic Answering of incoming calls.
- (b) The delay to answer **shall** comply with the requirements of AS/ACIF S002 [5] for a Loop-in PSTN line.

Compliance with Clause 5.8.7 should be checked by operation.

5.9 ISDN Network Ports

Where provided, the CE is to comply with the requirements for connection to ISDN Basic Access as specified in AS/ACIF S031 [8] and ISDN Primary Rate Access as specified in ACA Technical Standard 014 [1] and AS/ACIF S038 [9].

5.10 Conference bridges

The recommended performance requirements for conference equipment are contained in Appendix D.

6 TESTING

6.1 Verification of compliance with requirements

Compliance with all mandatory requirements in this AS/CA Standard is to be verified. This may be done by direct measurement, modelling and analysis, operation or inspection.

Methods for demonstrating compliance of CE with the requirements clauses specified in this Standard are described in Clauses 6.2 to 6.6.

Alternative methods of demonstrating compliance to those described may be used if the risk of passing non-compliant CE is not increased because of increased measurement uncertainty.

6.2 Standard test conditions

6.2.1 Unless this Standard provides otherwise, testing for compliance with this Standard should be conducted at the nominal supply voltage of the CE and within the following ranges of atmospheric conditions:

- (a) An ambient temperature in the range of 15°C to 25°C inclusive.
- (b) A relative humidity in the range of 30% to 75% inclusive.
- (c) An air pressure in the range of 86 kPa to 106 kPa inclusive.

6.2.2 Where elements in a test configuration are variable, the test should be carried out over the indicated range for that element.

6.2.3 Unless indicated elsewhere within this Standard—

- (a) the accuracy level of all measurements should be better than $\pm 2\%$ for voltage and current, $\pm 0.25\%$ for frequency and $\pm 0.5\%$ for time; and
- (b) the tolerance of the nominal 48 V d.c. test source should be ± 0.5 V.

6.2.4 Unless indicated elsewhere within this Standard for an individual test, all component values in the test configuration should have a tolerance of—

- (a) $\pm 1\%$ for resistance;
- (b) $\pm 1\%$ for capacitance; and
- (c) -0% , $+25\%$ for inductors.

6.3 Test configurations

Test configurations used should be outlined for each individual test. Test circuits other than those indicated in this Standard may be used but details of the circuits are to accompany test reports.

Note: Some tests for which no specific test configuration is provided in this Standard may be performed by inspection, as indicated in the appropriate requirements Clauses of this Standard.

6.4 Test level

Unless otherwise specified, transmission tests should be carried out with a send level of -10 dBm0 (i.e. -10 dBm at 0 dBr point).

6.5 Test frequencies

Test frequencies should be in the range of 300 Hz to 4000 Hz unless otherwise specified in the relevant requirement Clauses of this Standard. Sufficient measurements should be carried out around all nodal points of relevant masks, where applicable.

Note: Where the test frequencies are sub-multiples of the PCM sampling rate of 8000 Hz, an offset of 3 Hz to 20 Hz should be used to reduce errors in level measurements.

6.6 Parameters to be tested

All requirements specified in this Standard, applicable to the particular CE, should be verified by testing or inspection, as appropriate.

6.6.1 Early Guard – Incoming/Reversal on Seizure

For Early Guard – Incoming, refer to Clause 5.2.3.3. Figure 4 is the circuit to be used for sending the seizure signal in the form of a polarity reversal for early guard testing and a polarity reversal for Reversal on Seizure testing. Figure 5 is the circuit to be used for sending a seizure signal in the form of a ring signal. This test can be performed by blocking all Network Ports except one and making simultaneous 'early guard' and attempted outgoing seizure of the network port.

For Reversal on Seizure, refer to Clause 5.2.2.5.

6.6.2 Release blocking

Refer to Clause 5.2.2.2. This test can be performed using a similar test circuit to Figure 4 (without operation of switch SW1). Repeated call attempts should be made and the outgoing line monitored between clear down and re-seizure.

6.6.3 Automatic Guard

Refer to Clause 5.2.2.6. For open circuit voltages of less than 40 V d.c., the total series resistance is 2300Ω as shown in Figure 6. Where Automatic Guard by absence of service tones is

incorporated, the test configuration of Figure 7 should be used with the CE service tone detectors active.

6.6.4 Line leakage resistance

Refer to Clause 5.2.2.4. For a 50 k Ω resistance either across the network port terminals or from either network port terminal to ground, the test should be performed using the circuit shown in Figure 7.

6.6.5 Measurement of ring signal characteristics

Refer to Clause 5.3.2.1.

- (a) The minimum value of the ring voltage should be measured using the test circuit shown in Figure 13.
- (b) The frequency of the ring signal should be measured using the test circuit shown in Figure 13.
- (c) The harmonic content of the ring signal should be measured using a psophometer (with characteristics in accordance with ITU-T Recommendation O.41 [21]) set to the weighted mode, bridged measurement configuration. The procedure should use the test circuit shown in Figure 8 whilst the following steps are performed:

Step 1: Connect a psophometer across Port 0 as shown. Apply ring signal to Port 0 and note the reading at Port 0.

Step 2: Connect standard load (REN ~ 1) across Port 1. Apply ring signal simultaneously to both ports and note the reading at Port 0.

Step 3: Connect standard loads (REN ~ 1) across half of the maximum number of ports that may be simultaneously served with Ringing current from the ring generator. Alternatively load the ring generator with an equivalent load. Apply ring signal simultaneously to all of these ports and note the reading at Port 0.

Where the maximum number of ports (less Port 0), that can be simultaneously served by a ring signal source is an odd number, for the purpose of this test the next lowest whole number of ports will be sufficient.

Step 4: Repeat Step 3 for the maximum number of ports that may be simultaneously served by the ring generator and note the reading at Port 0.

- 6.6.6 Answer/Seizure/Hold signals
Refer to Clause 5.3.2.2. These signals should be tested using the test circuit shown in Figure 9 with switches SW2 open and SW1 closed. This test should be performed with R set to 300 Ω and 600 Ω in turn.
- 6.6.7 Idle/Release signals
Refer to Clause 5.3.2.3. These signals should be tested using the test circuit shown in Figure 9. The CE should detect both—
- (a) the idle signal if switches SW2 and SW1 are initially open and then switch SW2 is closed; and
 - (b) the release signal if switches SW2 and SW1 are initially closed and then switch SW1 is opened with R set to 300 Ω and 600 Ω in turn.
- 6.6.8 Decadic signals
- 6.6.8.1 Decadic signals should be measured over the range of make and break periods specified in Clause 5.3.3.1 and should use the test circuit shown in Figure 10 with R set to 600 Ω for Local Ports (On Premises) and 1800 Ω for Local Ports (Off Premises).
- 6.6.8.2 The test circuit should present a break termination of 50 k Ω and the impulse source should have a maximum contact bounce of 0.5 ms. The recording device should have accuracy greater than 1 ms. The test should include trains of the digit 0 or 9.
- 6.6.9 DTMF signals
- 6.6.9.1 DTMF signals should be measured over the range of conditions specified in Clause 5.3.3.2 and should use the test circuit shown in Figure 11.
- 6.6.9.2 Switch SW applies a seizure loop to the Local Port (On Premises). DTMF signalling can then take place.
Note: The DTMF source may be implemented as two low-distortion oscillators connected through a terminating network.
- 6.6.9.3 For measurement of CE generated DTMF signals at a digital port, the use of a test codec or digital equivalent complying with ITU-T Recommendation G.711 [18] A-law is required at the digital access point.
- 6.6.10 Local Port (Off Premises)
Refer to Clause 5.3.3. For answer/seizure/hold testing of this port refer to Clause 6.6.6 with R set to 600 Ω , 1200 Ω and 1800 Ω in turn.
- 6.6.11 Recall signal
Refer to Clause 5.3.2.4. For testing of this signal refer to Clause 6.6.6 with R set to 600 Ω for Local Ports (On Premises) and 1800 Ω for

Local Ports (Off Premises). For this test, the CE should not be in a state where a Facility Signal can be confused with decadic digit '1'.

6.6.12 Transmission measurements

6.6.12.1 Refer to Clauses 5.5 and 5.6. The transmission requirements of these Clauses should be measured between representative samples of all available port types. Transmission tests should be performed using the circuit of Figure 12 as a guide. The values of V_{-} , $R_{NETWORK}$ and R_{LOCAL} should be the minimum, maximum, and mid-range values selected from Table 5.

6.6.12.2 When performing return loss measurements, the return path of the four wire circuit in the call connection should be opened. To enable testing, instructions should be provided with the CE equipment to indicate the method of opening this return path. If the return path is not readily accessible then the far end of the test call connection should be terminated with the appropriate impedance given in Table 5, i.e. far end balance network, to achieve maximum semi-loop loss.

6.6.13 Power Spectral Density should be measured using the following:

- (a) A 10 kHz noise power bandwidth for frequencies between 3.4 kHz and 30.175 MHz.
- (b) A 1 MHz noise power bandwidth for frequencies between 300 kHz and 30.175 MHz as described in Clause 5.5.1.3.

PSD measurements should be performed during all active and idle port states as stated in Clause 5.5.1.3. These states will include, but may not be limited to Idle, Seize, Release/Cleardown, Dialling, Register Recall, depending upon the CE functions.

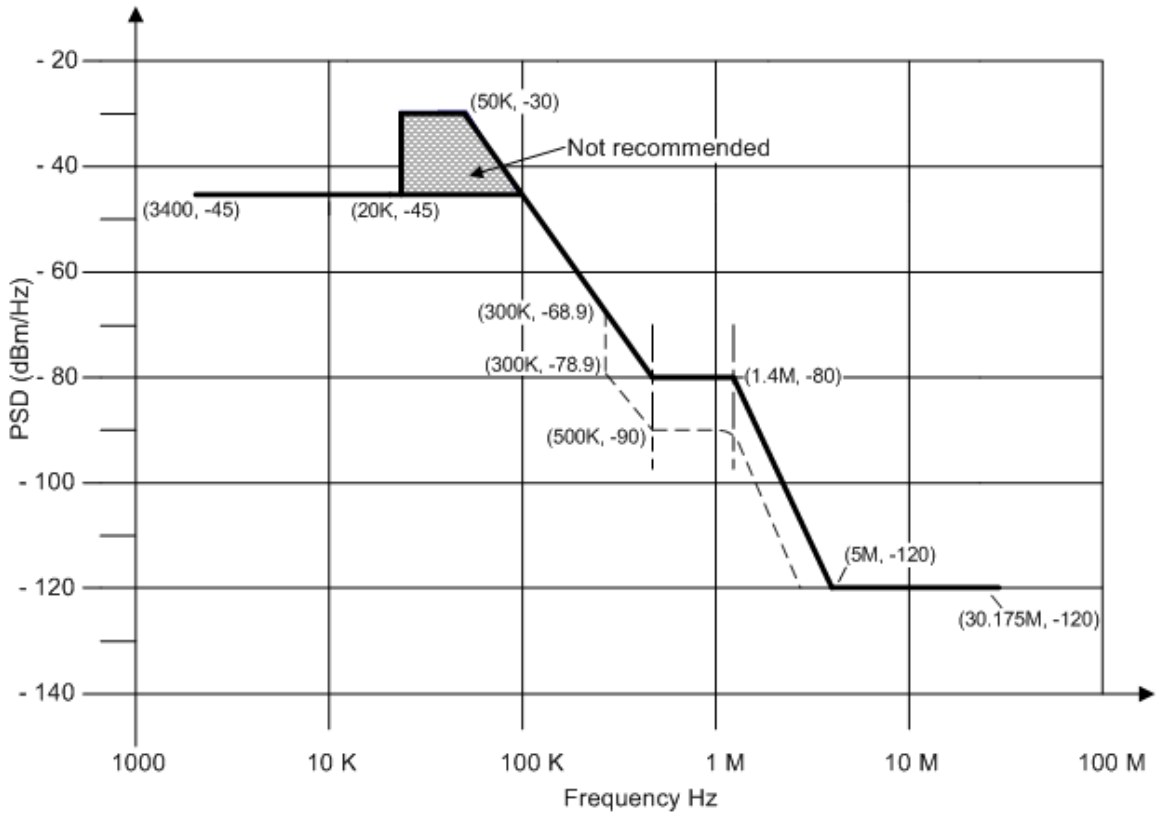
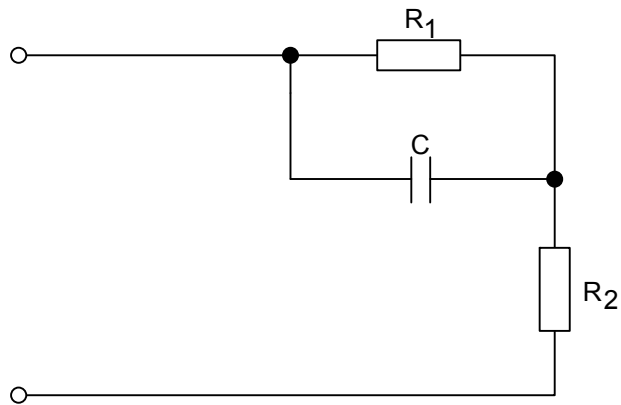
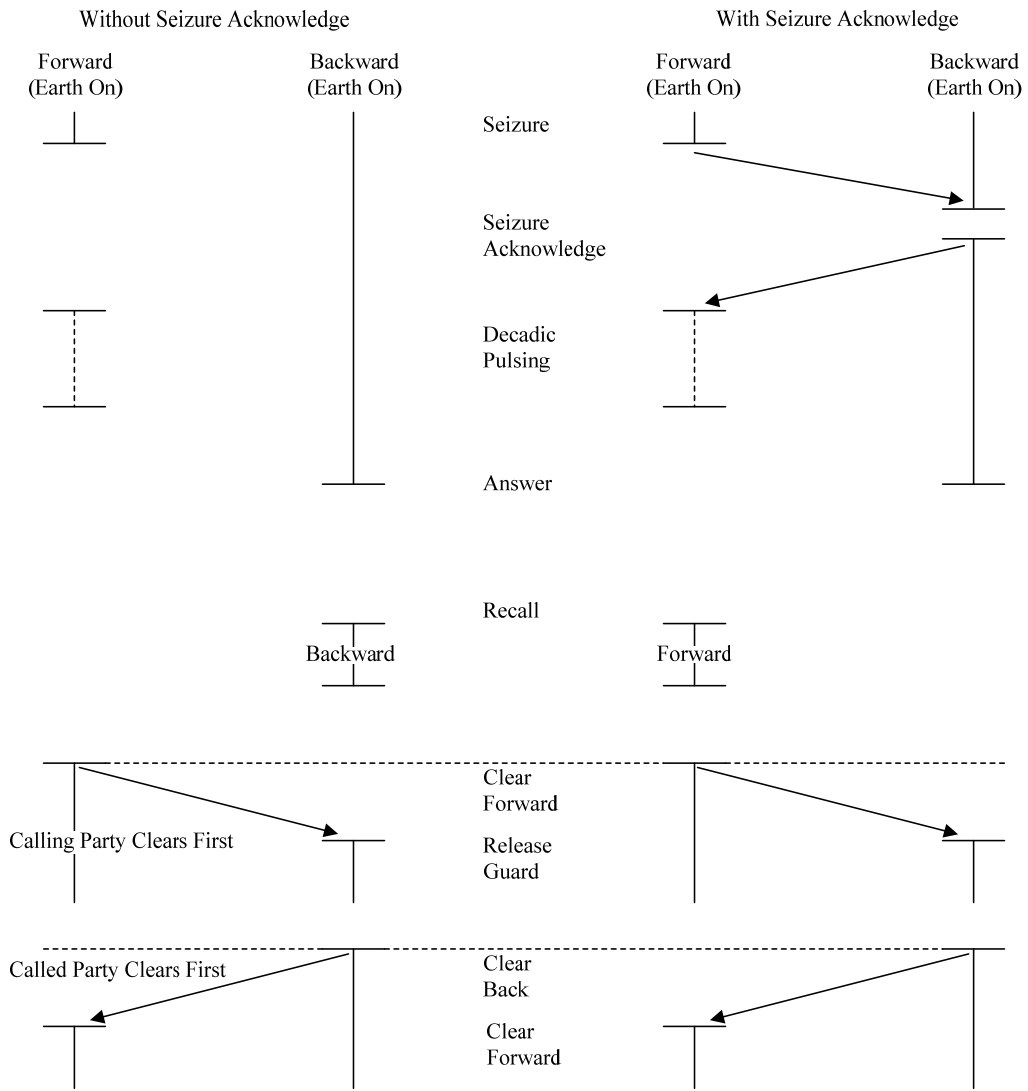

Figure 1
Ring Signal Power Levels limits above 3.4 kHz



$R_1 = 820 \Omega \pm 0.1\%$
 $R_2 = 220 \Omega \pm 0.1\%$
 $C = 115\text{nF} \pm 0.1\%$ or $120\text{nF} \pm 0.1\%$

Figure 2
Reference impedance (TN12) for impedance measurement



Note: This diagram represents the signalling for 'Earth-on-Idle'. Signalling for 'Earth-off-Idle' is the inverse.

Figure 3
C2 Series signalling

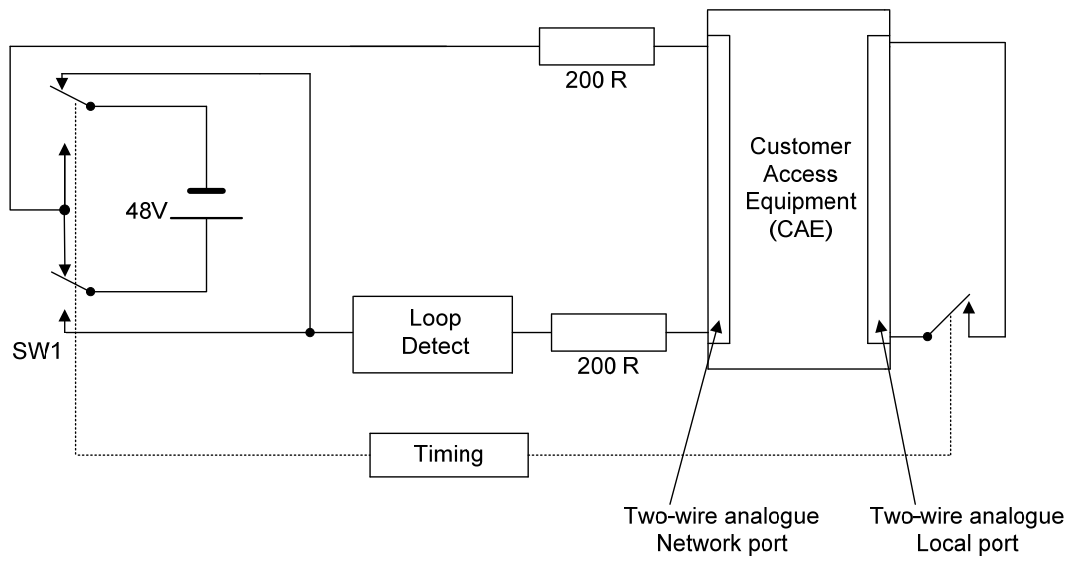

Figure 4

Early Guard (polarity reversal) and release blocking

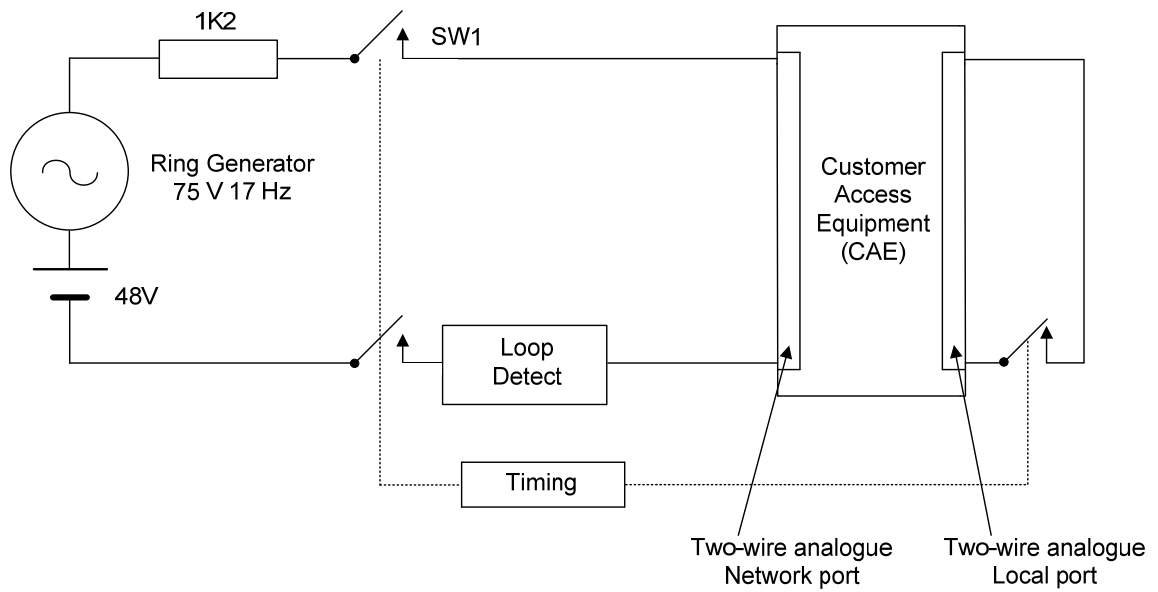

Figure 5

Early Guard (immediate ring)

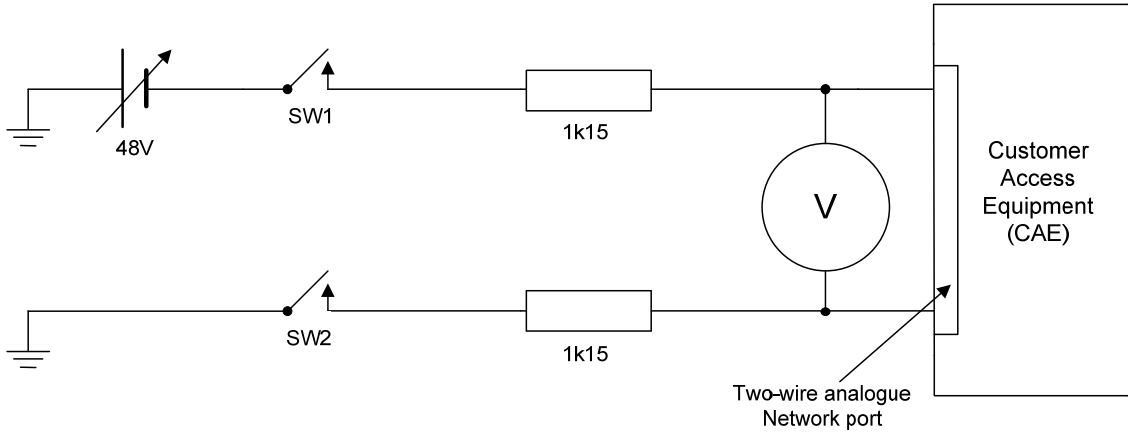

Figure 6
Automatic Guard

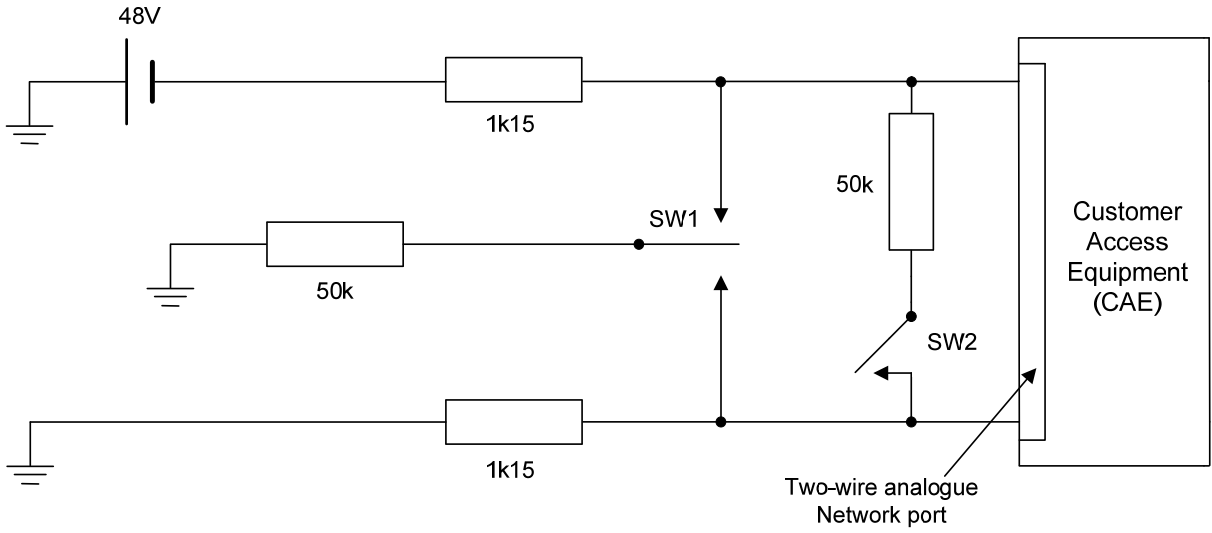

Figure 7
Line leakage resistance

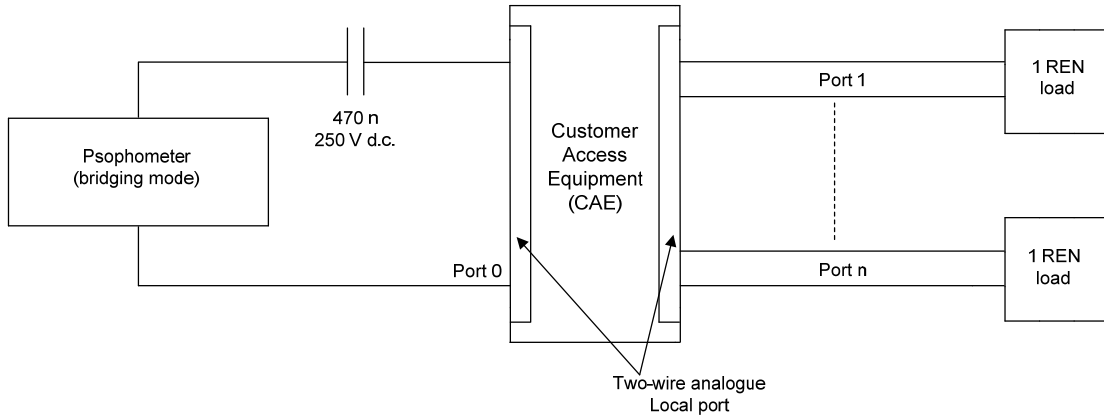

Figure 8
Harmonic content of ring signal

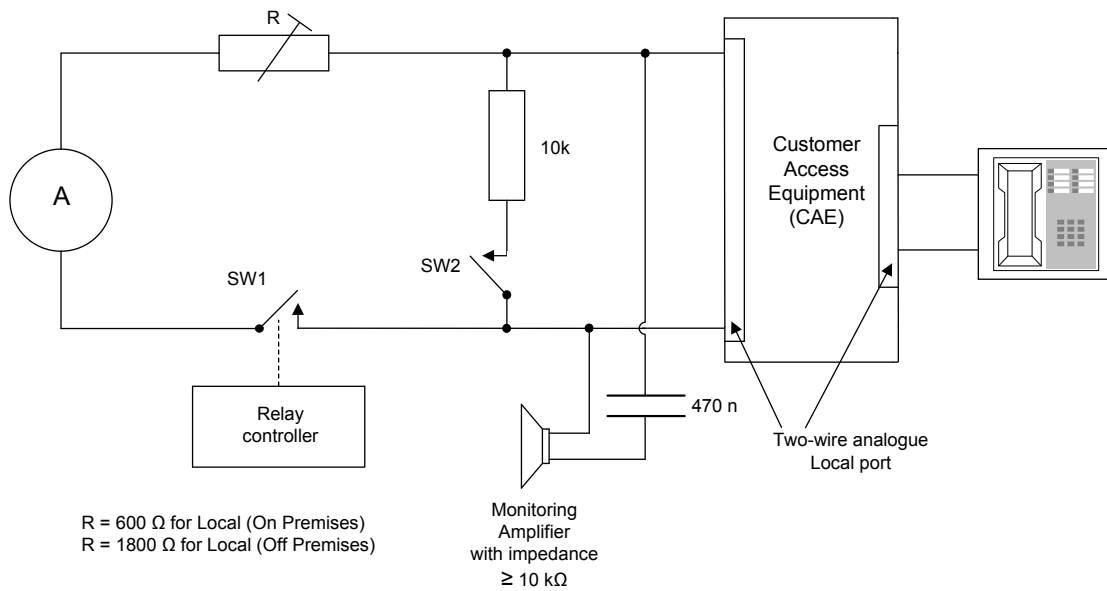

Figure 9
Answer/Seizure/Hold/Idle/Release/Facility signals

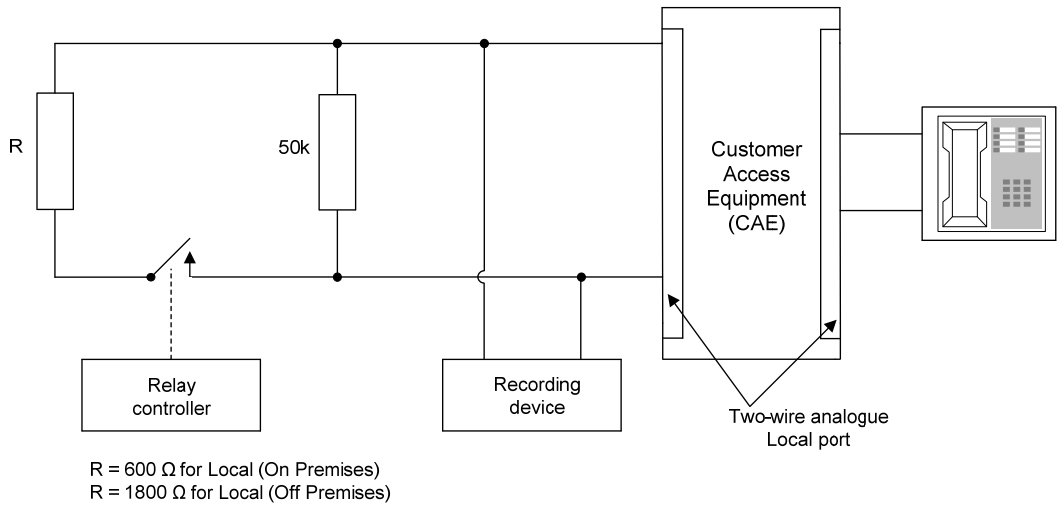

Figure 10
Decadic signals

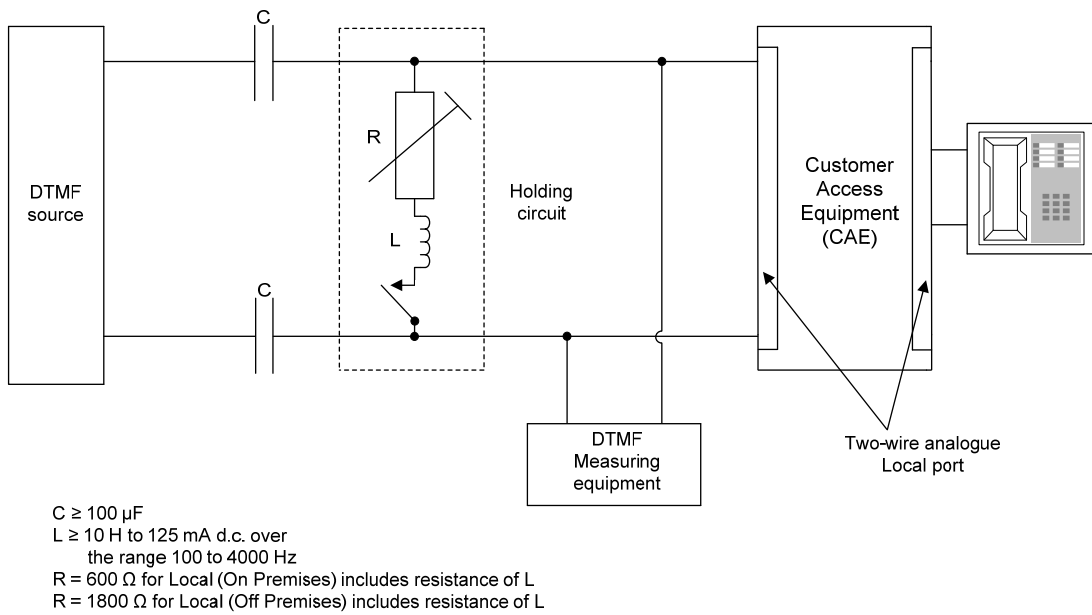
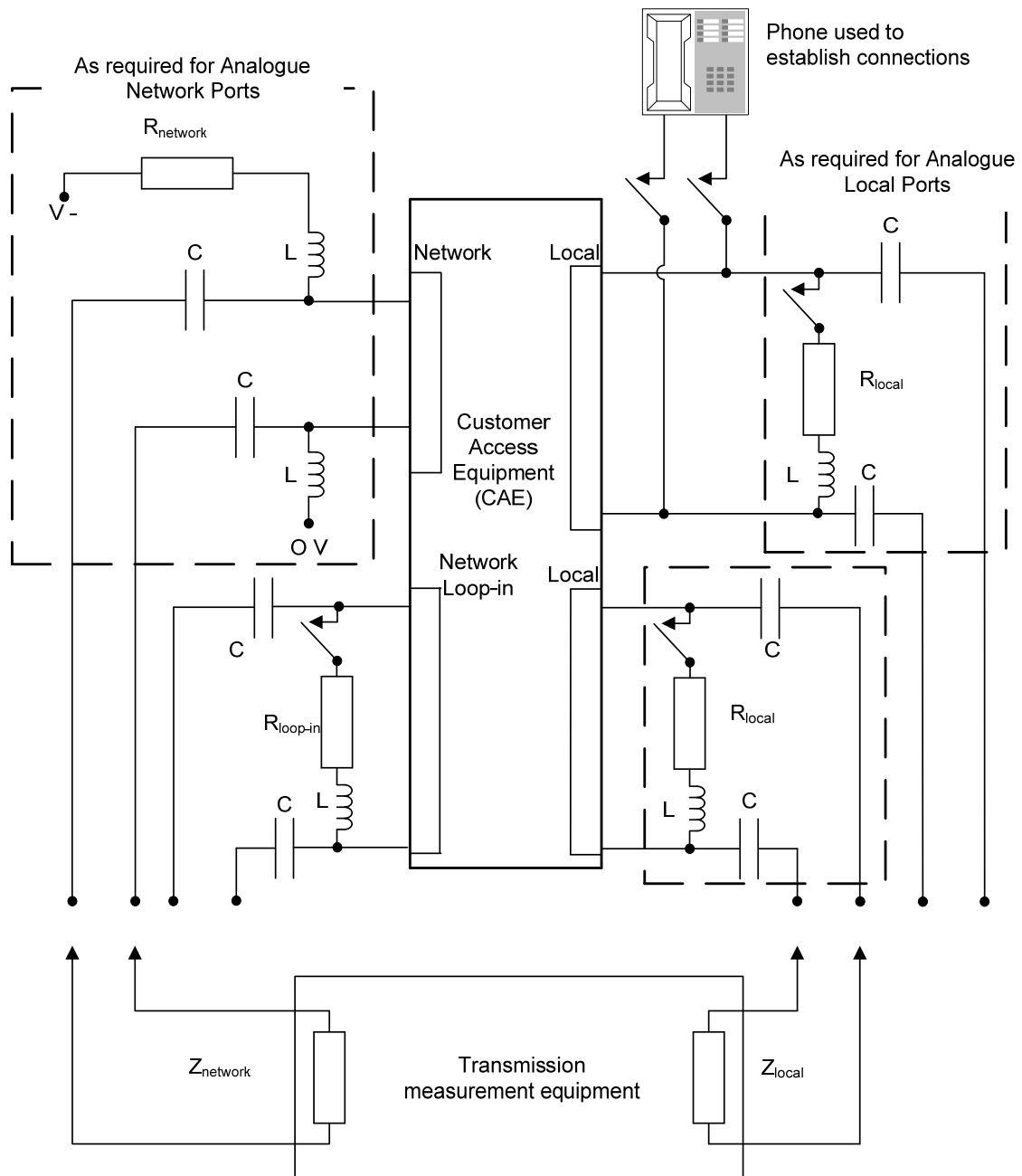

Figure 11
DTMF signals



$C \geq 100 \mu F$

$L \geq 10 H$ up to 125 mA d.c. over the range 100 to 4000 Hz

Z_{local} , $Z_{loop-in}$ and $Z_{network}$ = terminating impedance (see Table 4)

R_{local} , $R_{loop-in}$ and $R_{network}$ includes resistance of L (see Table 3)

Note: Measurement connections are shown for Analogue ports. For Digital Network ports, connections using appropriate Digital Transmission Measuring equipment must be made to the digital port interface.

Figure 12
Transmission measurement configuration

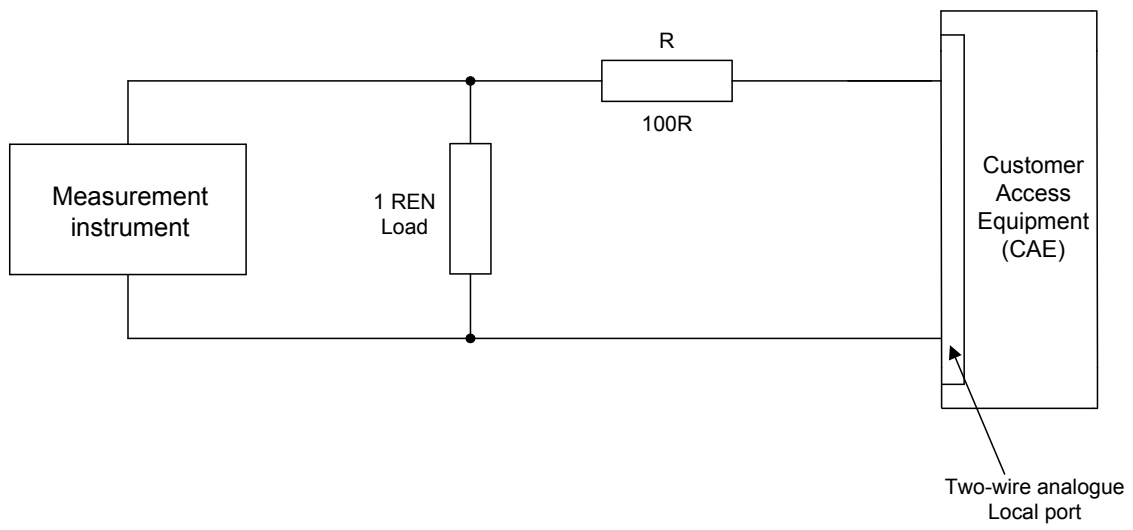

(a) Local Port (On Premises)

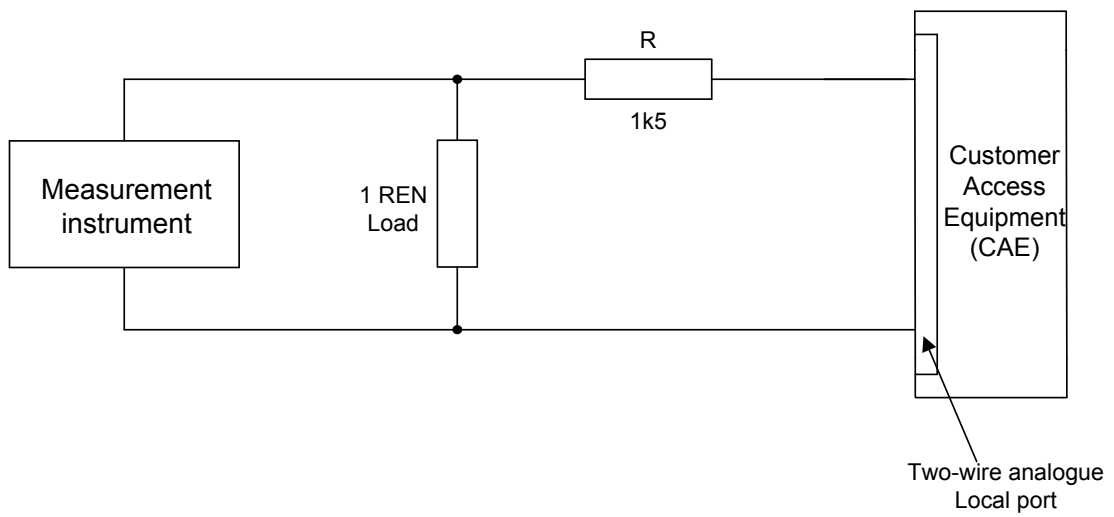

(b) Local Port (Off Premises)

Figure 13
Measurement of ring signals

APPENDIX A

A Four-Wire Voice Frequency Interfaces

A1 General

- A.1.1 The availability of this facility is subject to negotiation with the carrier or carriage service provider. Four-wire VF interfaces employ signalling transfer by means of separate E & M signalling leads. These interfaces may be used to provide access to PSTN and tie-lines.
- A.1.2 Signal transfer is by application of an earth potential on the M-Lead and reception of an earth potential on the E-Lead for forward and backward signal transmission respectively.
- A.1.3 Figure A1 illustrates the interconnection.
- A.1.4 For PSTN E & M access lines, the signal durations and tolerances when transferred by E and M leads **shall** be identical with signals specified in AS/ACIF S002 [5] for 2 wire loop interface (ring-in/loop-out or loop-in). For tie-lines, the signal durations and tolerances **shall** be as specified in Clause 5.6 of this Standard.

A2 CE Interface with E & M Signalling (including C2)

- A.2.1 CE Interface E & M Signalling leads are to comply with the following:
- (a) When the M-Lead is extending earth the maximum voltage drop between FE terminal and the M-Lead terminal **shall** be 1 V for all M-Lead currents up to 25 mA.
 - (b) When the M-Lead presents an open-circuit and -65 V is applied between the M-Lead terminal and the FE terminal, the leakage current **shall not** exceed 150 μ A.
 - (c) The M-Lead switching device **shall** be rated for a continuous M-Lead current of 60 mA.
 - (d) The E-Lead **shall** recognise the following conditions as earth:
 - (i) Any voltage between 0 and -4.5 V applied between the E-Lead terminal and FE terminal.
 - (ii) Any resistance less than 50 Ω connected between the E-Lead terminal and FE terminal.
 - (e) The E-Lead current **shall** be between 1 and 25 mA when earth as in A2.1 (a) is applied to the E-Lead terminals.
 - (f) The E-Lead **shall** recognise an open-circuit condition when the resistance between the E-Lead terminal and FE terminal exceeds 20 k Ω .
 - (g) Under open-circuit conditions the E-Lead terminal voltage **shall** be less than -10 V (i.e. at least 10 V negative) to ensure that the

earth and open-circuit states can readily be distinguished under test conditions.

A.2.2 Where the CE interfaces directly to PCM multiplex equipment, the CE interface E & M leads **shall** be connected to the PCM multiplexer E & M leads respectively.

Note: The PSTN interface provides the following conditions on the E & M leads of a PCM multiplexer with which the E & M leads of the CE is to interwork:

- (a) The M-Lead provides a contact wetting DC potential of at least -10 V (open-circuit) and between 1 and 25 mA (short-circuit to earth).
- (b) An earth is defined as existing when a resistance between 0 and 50 Ω is applied between the FE terminal and the M-Lead. An open circuit is defined as existing when a resistance exceeding 20 k Ω is connected between FE terminal and the M-Lead.
- (c) When the E-Lead is in the short circuit (extending earth) condition and the E-Lead current is 60 mA, the voltage drop between the E-Lead terminal and the FE terminal is less than 4 V.
- (d) When the E-Lead is in the open circuit (not extending earth) condition and -52 V is applied to the E-Lead terminal, the leakage current will not exceed 150 μ A.
- (e) The E-Lead switching device is rated for a continuous E-Lead current of 60 mA.

Table A1

E & M Signalling states – CE to PSTN

CE condition	Resulting E & M lead state M
On-hook	Open-circuit
Off-hook	Earth

Table A2

E & M Signalling states – PSTN to CE

State of E & M lead E	Resulting CE signal
Open-circuit	No Ring or Idle
Earth	Ring or Seize

A3 Proceed to send – Wink Start (outgoing call to PSTN)

Where a CE has the capability to receive a Wink Start from the PSTN, it **shall** recognise a pulsed earth applied to the E-Lead with a duration in the range 135 ms to 165 ms inclusive, occurring 90 ms and later after the CE Network Port has applied a continuous earth to the M-Lead.

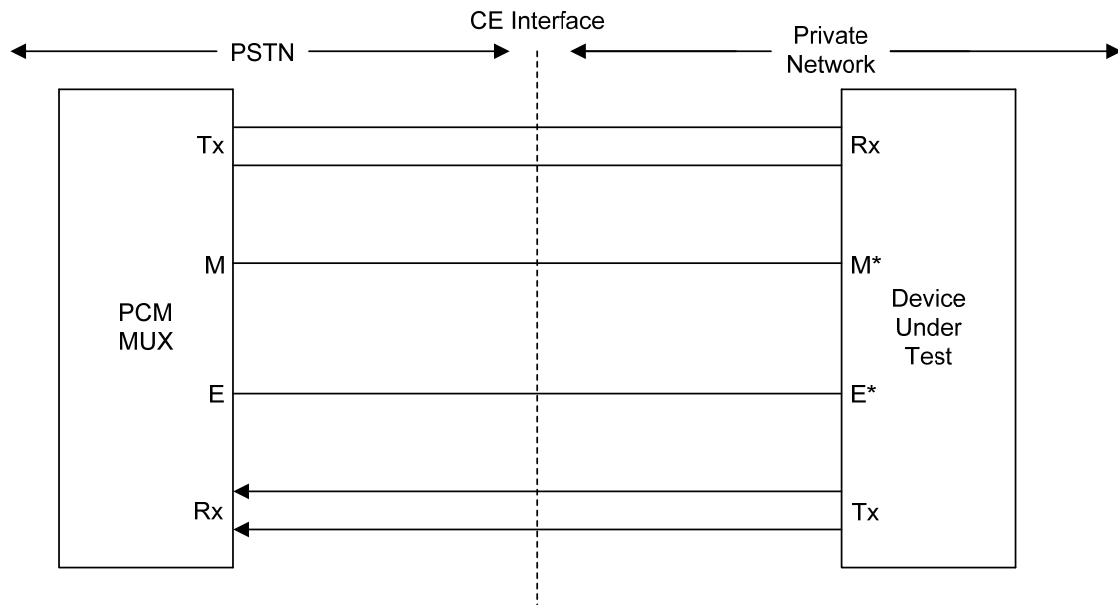

Note: Connections shown with an asterisk (*) assume that CE is a terminating device, i.e. a CAE. If CE is transmission equipment, the signalling connections are to be transposed, i.e. M to E and vice versa.

Figure A1

Four-wire CE interface with E & M Signalling

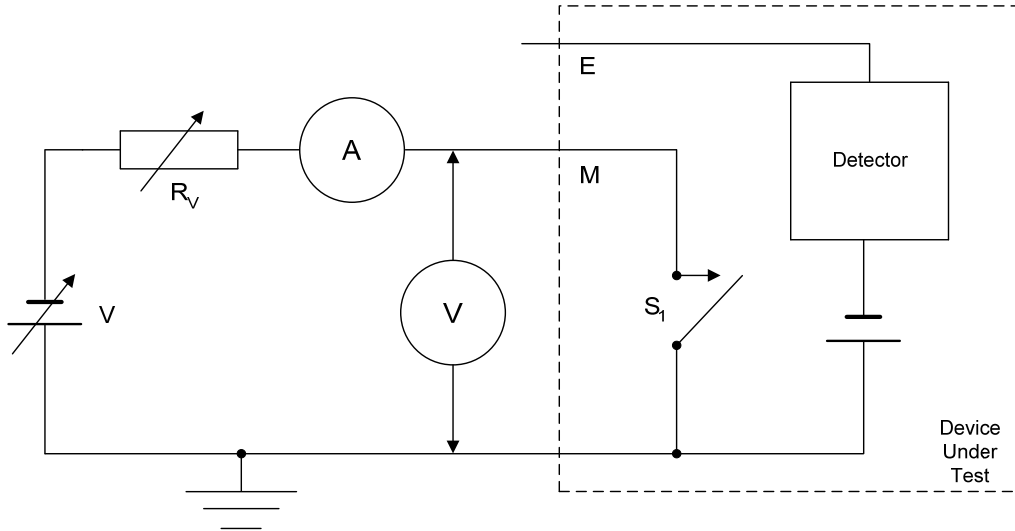

Note: All measurements to accuracy better than:
 ± 2% voltage and current
 ± 0.5% time
 ± 0.25% frequency
 ± 0.2% dB power level

M-lead earthed for voltage drop and Continuous current test
 M-lead open for leakage current test
 Set voltage and resistance as required
 V = -4 to -65 V

Figure A2

Test circuit for E & M Signalling – M-Lead voltage drop; M-Lead continuous current and M-Lead leakage current tests

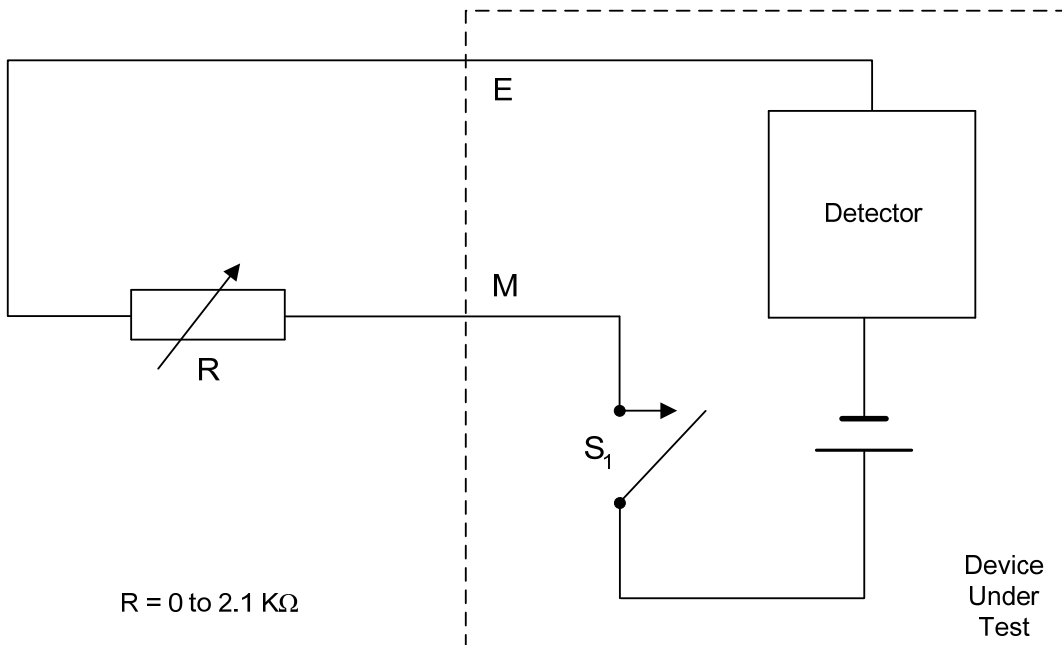
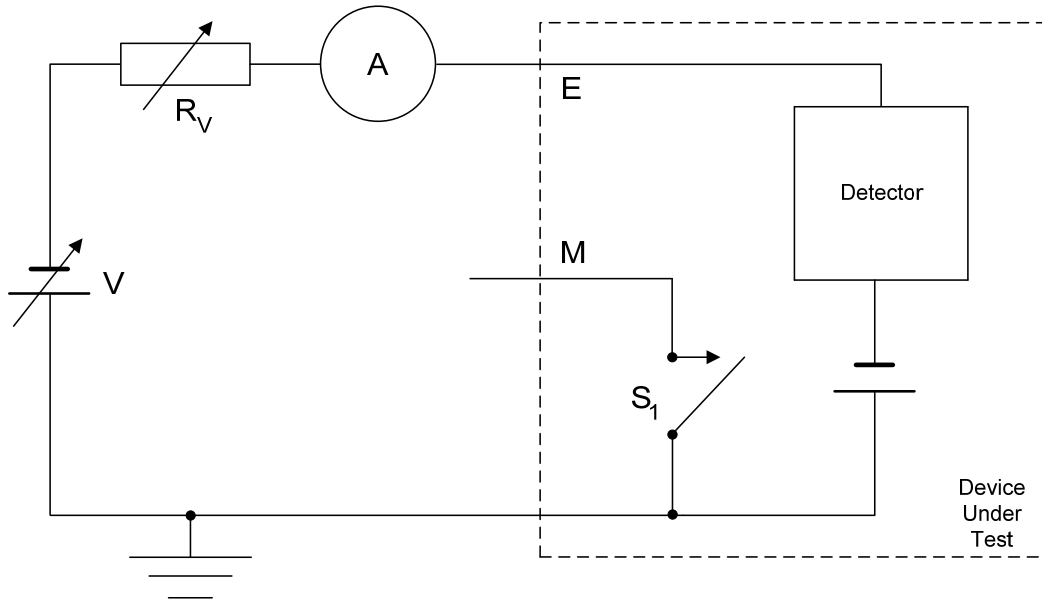

Figure A3

Test circuit for E & M Signalling limits



Note: All measurements to accuracy better than: $R_V = 0$ to $2.1 \text{ k}\Omega$
 $\pm 2\%$ voltage and current $V = 0$ to -4.5 V
 $\pm 0.5\%$ time
 $\pm 0.25\%$ frequency
 $\pm 0.2\%$ dB power level

Figure A4
Test circuit for E & M Signalling limits E-Lead sensitivity test

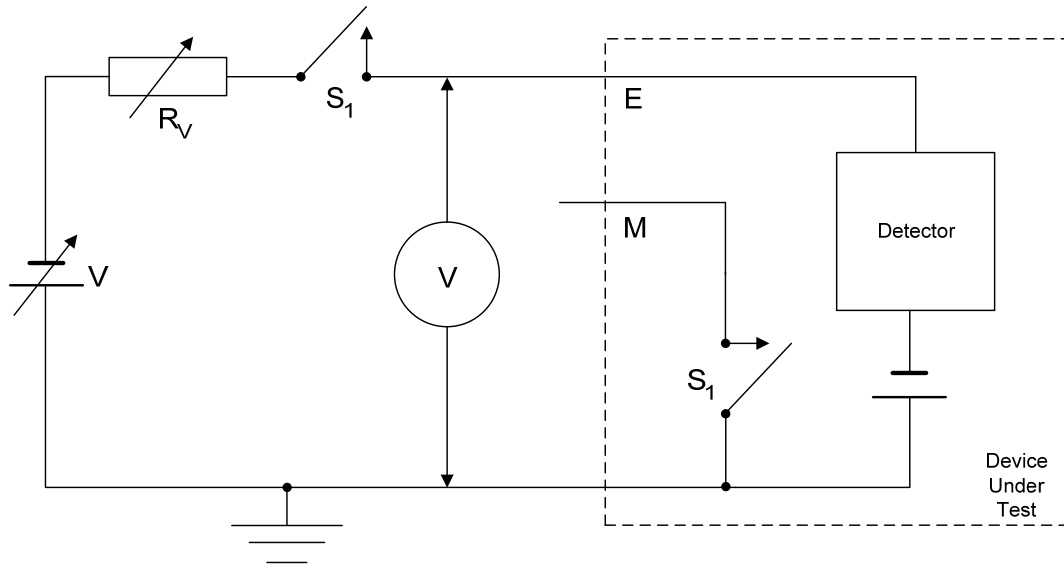

Note: All measurements to accuracy better than: $R_V = 0$ to $24 \pm 1\% \text{ k}\Omega$
 $\pm 2\%$ voltage and current $V = 0$ to -4.5 V
 $\pm 0.5\%$ time
 $\pm 0.25\%$ frequency
 $\pm 0.2\%$ dB power level

Figure A5

Test circuit for E & M Signalling – E-Lead open circuit and leakage test

APPENDIX B

B 2048 KBIT/S PSTN INTERFACE – CAS PROTOCOL

B1 General

- B.1.1 This Appendix specifies the signalling requirements for the digital connection of a CE to the PSTN for unidirectional or bothway operation. The signalling scheme uses CAS in timeslot 16 for line signals. Information signals are sent as either line signals (Decadic Pulses) or in-band tones (DTMF or MFC).
- B.1.2 Figure B1 and Figure B2 describe the signalling states and transitions for the signalling protocol for outgoing and incoming calls.

B2 Signalling

- B.2.1 The timeslot 16 signal is a two bit protocol and **shall** be as defined in Table B1 for calls outgoing from CE and Table B2 for calls incoming to CE.
- B.2.2 Faults detected at the CE in the PCM equipment may be indicated by a Service Alarm as defined in Tables B1 and B2. Such faults **shall** initiate the sending of the PCM Fault signal, on idle channels. When the fault conditions are cleared the channel **shall** return to the idle state.
- B.2.3 The Seize Acknowledge signal as defined in Tables B1 and B2 **shall not** be returned in response to a Seize Forward on decadic or DTMF signalling inlets until the CE is ready to receive decadic or DTMF signals.
- B.2.4 The bits 'a' and 'b' in Tables B1 and B2 are as defined in ITU-T Recommendation G.704 [17]. The bits 'c' and 'd' are not used in this scheme and **shall** be set in accordance with ITU-T Recommendation G.704 [17] Table 9/704 Note 3 to be 'c'= 0 and 'd'= 1.

Table B1
Signalling codes – Outgoing call

Forward		State	Backward	
a _f	b _f		a _b	b _b
1	0	Idle	1	0
0	0	Seize Forward		
		Seize Acknowledge	1	1
		Answer	0	1
1	0	Clear Forward		
		Release Guard (Note)	1	0
		Line lockout	1	1
		Blocking	1	1
1	0	Dial Break		
0	0	Dial Make		
		Meter Pulse	1	1
1	0	Timed Loop Break	1	1
1	1	PCM Fault	1	1

Table B2
Signalling codes – Incoming call

Forward		State	Backward	
a _f	b _f		a _b	b _b
1	0	Idle	1	0
0	0	Seize Forward		
		Seize Acknowledge (Note)	1	1
		Answer/Re-answer	0	1
1	0	Clear Forward		
		Clear Back	1	1
		Release Guard	1	0
		Blocking	1	1
1	0	Dial Break		
0	0	Dial Make		
1	0	Timed Loop Break	1	1
1	1	PCM Fault	1	1

Note: Release Guard is defined as the transition to idle in response to a Clear Forward signal.

B3 Timing

- B.3.1 Signalling state transition times
 - B.3.1.1 A signalling state **shall** only be accepted as valid if it is observed in at least 5 consecutive multiframes.
 - B.3.1.2 If a change in signalling states requires a change in both bits, then these bits **shall** both change in the same multiframe (2 ms).
- B.3.2 State and signal limits
 - B.3.2.1 General

Signals are continuous except for those described in Tables B3 and B4, for which the indicated timing requirements **shall** apply.

Table B3
Timing limits – Outgoing call

Description	Timers	Value (ms)
Dial Make		30 to 50
Dial Break		50 to 70
Meter Pulse (Note 1)	T2 and T7	90 to 190
Release Guard	T5	80 to 120
Interdigital Pause		400 to 1600
Timed Loop Break (facility request) (Note 2)	T6	80 to 100

Note 1: Timer values include signal validation time, refer Clause B3.1.1.

Note 2: Recognition of the Timed Loop Break (facility request) signal may not be provided by a carrier or carriage service provider.

Note 3: A meter pulse is optionally available as a signal from the PSTN for outgoing calls.

Table B4
Timing limits – Incoming call

Description	Timers	Value (ms)
Dial Make		30 to 50
Dial Break		50 to 70
Timed Loop Break (facility request) Note 1	T6	80 to 100
Release Guard	T5	80 to 120
Interdigital Pause		400 and greater

Note 1: Timed Loop Break (facility request) recognition may be optionally available from a carrier or carriage service provider.

Note 2: Timer values include signal validation time, refer Clause B3.1.1.

B.3.2.2 Outgoing calls

B.3.2.2.1 The time supervision period for receipt of the Seize Acknowledge signal when an outgoing call is attempted **shall** be in the range 810 ms to 2000 ms inclusive from the instant of application of the Seize signal.

B.3.2.2.2 The timing, level and frequency requirements for the sending of DTMF in-band signals **shall** comply with the ring-in/loop-out requirements in AS/ACIF S002 [5].

Note: No absolute level adjustment is required to compensate for the difference in relative level between the analogue interface in AS/ACIF S002 [5], and the digital interface in this Standard.

B.3.2.3 Incoming calls

B.3.2.3.1 A valid Seize Acknowledge signal **shall** be returned within 810 ms of the instant of application of the Seize signal (subject to the availability of digit address receivers, etc.).

B.3.2.3.2 The timing, level and frequency requirements for the reception of MFC and DTMF signals **shall** comply with the loop-in line requirements in AS/ACIF S002 [5].

Note: No absolute level adjustment is required to compensate for the difference in relative level between the analogue interface in AS/ACIF S002 [5] and the digital interface in this Standard

B4 Action on faults and transmission degradation

B.4.1 A link may fail to perform satisfactorily due to equipment failures in transmission or switching equipment, or due to transmission path degradation. The Service Alarm (SA) indicates that the transmission link has failed. This alarm when provided **shall** operate within 2 ms of transmission errors being detected to avoid recognition of corrupted signals. The SA **shall** operate at the remote end within 10 ms of activation of the Remote Alarm Signal.

Note: For further information relating to Service Alarms, refer to ITU-T Recommendation G.732 [19] § 4.2.

B.4.2 Equipment failures or transmission path degradation should not cause wrong number, false answer or unnecessary call clear down during transient degradations. To achieve this protection, the following action **shall** be taken on the occurrence of a fault or degradation:

- (a) During idle the link **shall** be blocked to calls.
- (b) During call set-up the call **shall** be cleared immediately, independent of the duration of the fault or degradation (to prevent wrong numbers that may occur due to lost or split digit signals).
- (c) During call answer or clear back states, the call **shall** be held for a nominal 6 s before being cleared. This avoids clearing a call during transient degradations. False answering or metering is avoided by freezing the state of the line signals in those states

that existed at the time of the fault, and by clearing the call when 6 s (T3) has expired. At the incoming end, timer T4 is set to 7 s to ensure that the outgoing end is released first.

B5 Summary of actions appropriate to various signals

Tables B5 and B6 together with the associated notes summarise the actions appropriate to the various signal combinations.

Table B5
Signalling conditions – originating call from the CE

State	Code sent from CE	Code received from PSTN			
		$a_b = 0 \ b_b = 0$	$a_b = 0 \ b_b = 1$	$a_b = 1 \ b_b = 0$	$a_b = 1 \ b_b = 1$
Idle	$a_f = 1 \ b_f = 0$	Incoming Seizure or Abnormal (Note 1)	Abnormal (Note 2)	Idle	Blocking
Seizure	$a_f = 0 \ b_f = 0$	Double Seizure or Abnormal (Note 3)	Abnormal (Note 2)	Outgoing Seizure (Note 4)	Seizure Acknowledge
Seized Outgoing Note 5	$a_f = 0 \ b_f = 0$	Abnormal (Note 6)	Answer (Note 7)	Abnormal (Note 8)	Seizure Acknowledge (Note 10)
Answered	$a_f = 0 \ b_f = 0$	Abnormal (Note 6)	Answer	Abnormal (Note 9)	Meter Signal (Note 10)
Meter	$a_f = 0 \ b_f = 0$	Abnormal (Note 6)	Answer	Abnormal (Note 9)	Meter Signal (Note 10)
Clear Forward	$a_f = 1 \ b_f = 0$	Abnormal (Note 2)	Clear Forward	Release Guard Idle	Clear Forward
Release Guard/Idle	$a_f = 1 \ b_f = 0$	Seizure or Abnormal (Note 1)	Abnormal (Note 2)	Idle	Blocking
Blocking	$a_f = 1 \ b_f = 0$	Abnormal (Note 2)	Abnormal (Note 2)	Idle	Blocking

Note 1: When the channel is operating in a bothway mode and is idle, receipt of this signal constitutes a seizure from the other end which then assumes the status of the outgoing end.

When the channel is operating in a one-way mode, this signal is abnormal and action should be taken in accordance with Note 2.

Note 2: In these abnormal conditions the CE should prevent outgoing seizures of the channel.

Note 3: On recognition of double seizure, the CE should reject or re-route the CE outgoing call attempt, prevent further seizures and accept the incoming PSTN call.

The PSTN will continue to send a seize and wait for a seizure acknowledge signal from the CE. Non recognition of the seizure acknowledge signal will result in PSTN action equivalent to that described in Note 4.

- Note 4: If the seizure acknowledge signal is not recognised within a time supervision period of 810 to 2000 ms after sending the seizure signal, a maintenance alarm should be operated and either a busy signal applied to the CE Local Port or a repeat attempt made to set up the call on another channel. The CE should continue to send the seizure signal and prevent outgoing seizures of the channel. If the seizure acknowledge signal is recognised after the time supervision period has elapsed, a clear forward signal should be sent.
- Note 5: For Decadic Signalling the Dial Break is equivalent to a timed Clear Forward during the seized outgoing state after receipt of a seizure acknowledge.
- Note 6: In these circumstances the CE should respond by sending a clear forward, prevent outgoing seizure, and await an idle condition from the PSTN.
- Note 7: If an answer signal is recognised prematurely, i.e. before the completed address has been sent, the call should be released by the CE and a busy signal applied to the CE Local Port.
- Note 8: On receipt of $a_b = 1$ and $b_b = 0$ by the CE after recognition of the seizure acknowledge and prior to recognition of the answer signal a clear forward signal should be sent.
- Note 9: In the case of recognition $a_b = 1$ and $b_b = 0$, whilst in receipt of answer or meter pulse, the CE should force release the call. Also see Note 6.
- Note 10: LINE LOCKOUT is defined as a state in which only the individual channel equipment is occupied. There is no occupancy of common exchange resources. Busy Tone or Congestion Tone may be applied for a period prior to setting an individual channel in the LINE LOCKOUT.

LINE LOCKOUT may occur before or after reception of an Answer signal (i.e. in the SEIZED OUTGOING or in the ANSWER states). An identifiable signal transition to indicate that an individual channel has entered the LINE LOCKOUT state will not occur during the SEIZED OUTGOING state, as the signal code for Seize Acknowledge and Line Lockout are identical. An identifiable signal transition to indicate that an individual channel has entered the LINE LOCKOUT state will occur when the individual channel is in the ANSWER state; LINE LOCKOUT can be recognised by the expiration of timer T7 following reception of $a_b b_b = 1, 1$.

Table B6
Signalling conditions – incoming call to the CE

State	Code sent from CE	Code received from PSTN			
		$a_f = 0 \ b_f = 0$	$a_f = 0 \ b_f = 1$	$a_f = 1 \ b_f = 0$	$a_f = 1 \ b_f = 1$
Idle Released	$a_b = 1 \ b_b = 0$	Seizure	Fault (Note 1)	Idle	Fault (Note 1)
Seizure Acknowledge Seized Incoming (Note 2)	$a_b = 1 \ b_b = 1$	Seizure Acknowledge	Fault (Note 3)	Clear Forward	Fault (Note 3)
Answer	$a_b = 0 \ b_b = 1$	Answer Re-answer	Fault (Note 4)	Clear Forward (Note 5)	Fault (Note 4)
Clear Back	$a_b = 1 \ b_b = 1$	Clear Back	Fault (Note 4)	Clear Forward (Note 5)	Fault (Note 4)
Blocking	$a_b = 1 \ b_b = 1$	Fault (Note 6)	Fault (Note 7)	Blocking	Fault (Note 7)
Invalid Code (Note 2)	$a_b = 0 \ b_b = 0$	Fault (Note 6)	Fault (Note 7)	Abnormal (Clear Forward (Note 8))	Fault (Note 9)

Note 1: When idle, if b_f changes to 1, then b_b should also be changed to 1 to indicate a fault. For a bothway channel if $a_b = 1$ and $b_b = 1$ in either direction, this will constitute a blocking signal.

Note 2: (a) On recognition of double seize, the PSTN will wait for a seizure acknowledge signal from the CE. The CE should reject or re-route the outgoing CE call attempt.

(b) If the channel is operating in a one-way mode, the Seizure Acknowledge signal should be recognised as abnormal and action taken at the CE to prevent new seizures of the channel.

Note 3: On receipt of a fault signal (and service alarm signal) any equipment seized in the forward direction should be released. $a_b = 1$ and $b_b = 1$ should be maintained until the service alarm is removed and a clear forward is received.

While the backward signal remains unchanged the channel can change from seizure acknowledge to fault and possibly to blocking before it returns to idle.

Note 4: No action should be taken to clear down the call connection until the expiry of a time supervision period of 6 ± 1 s, to guard against loss of calls due to short transmission impairments.

Within the time supervision period, the channel should remain in the answer state subject to A and B party's control of the channel.

At the expiry of the time supervision period the channel should be force released and marked as faulty/blocked until the service alarm is removed.

Note 5: After clear forward is recognised and until the release guard time expires, all transitions in the forward direction should be ignored.

Note 6: In this case immediate action is not necessary. However, rapid release of the channel by the PSTN should occur if the CE simulates the answer condition by sending $a_b = 0$ and $b_b = 1$.

Note 7: Under these conditions no action is to be taken.

Note 8: The PSTN may respond to a $a_b = 0$, $b_b = 0$ with a clear forward signal.

Note 9: On receipt of a fault signal, any equipment seized in the forward direction should be released. $a_b = 1$ and $b_b = 1$ should be sent until the fault is cleared and a clear forward received.

Note 1: For CAE originating calls a Facility Request Signal is sent to the PSTN exchange as a Timed Clear Forward Signal of duration T6.
 Note 2: When dual seizure occurs the CAE allows the incoming call to terminate and reselects another idle channel for the outgoing call.

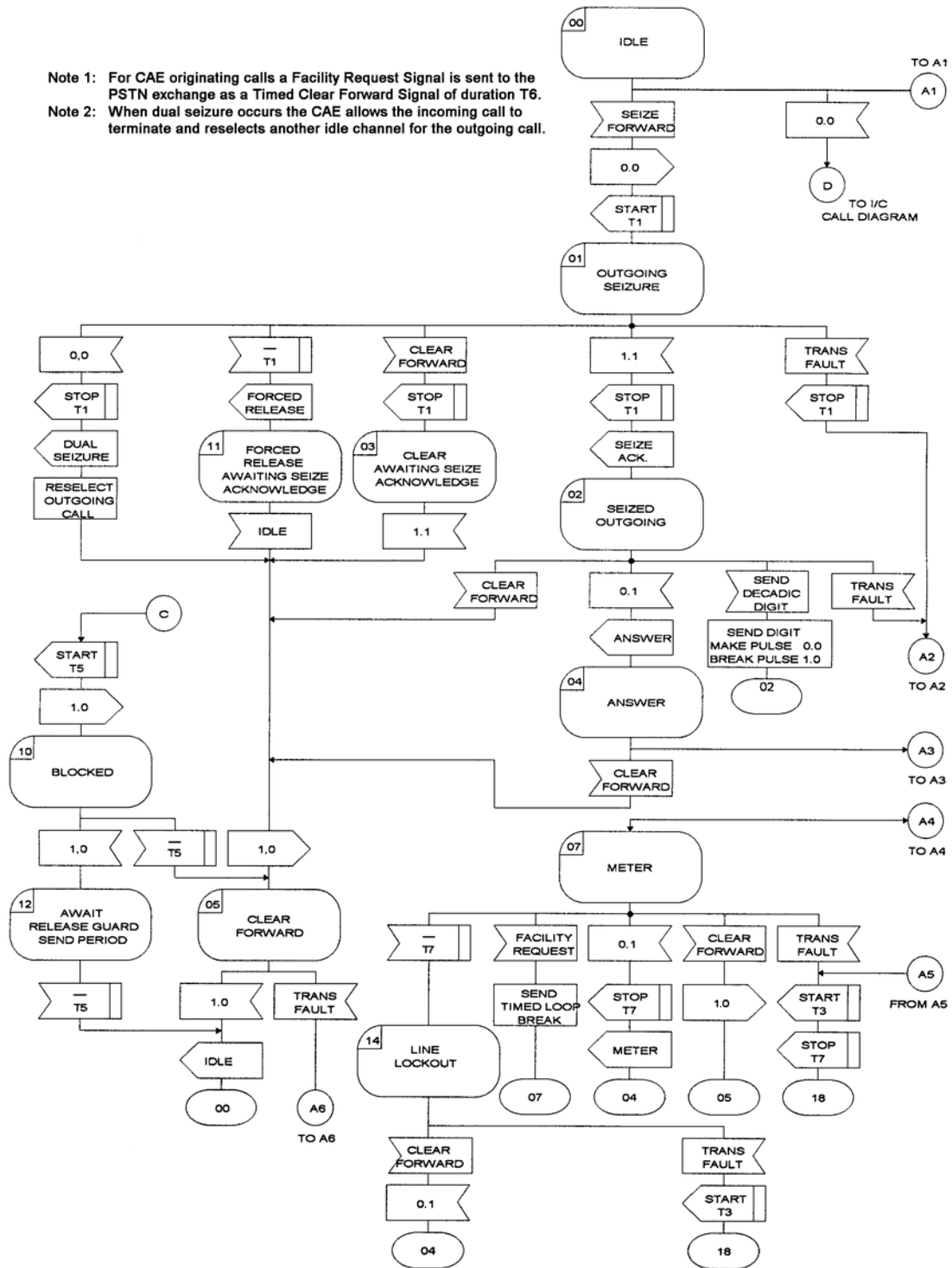

Figure B1

**CAS Line signalling functions – outgoing calls
 State and transition diagram (Sheet 1 of 2)**

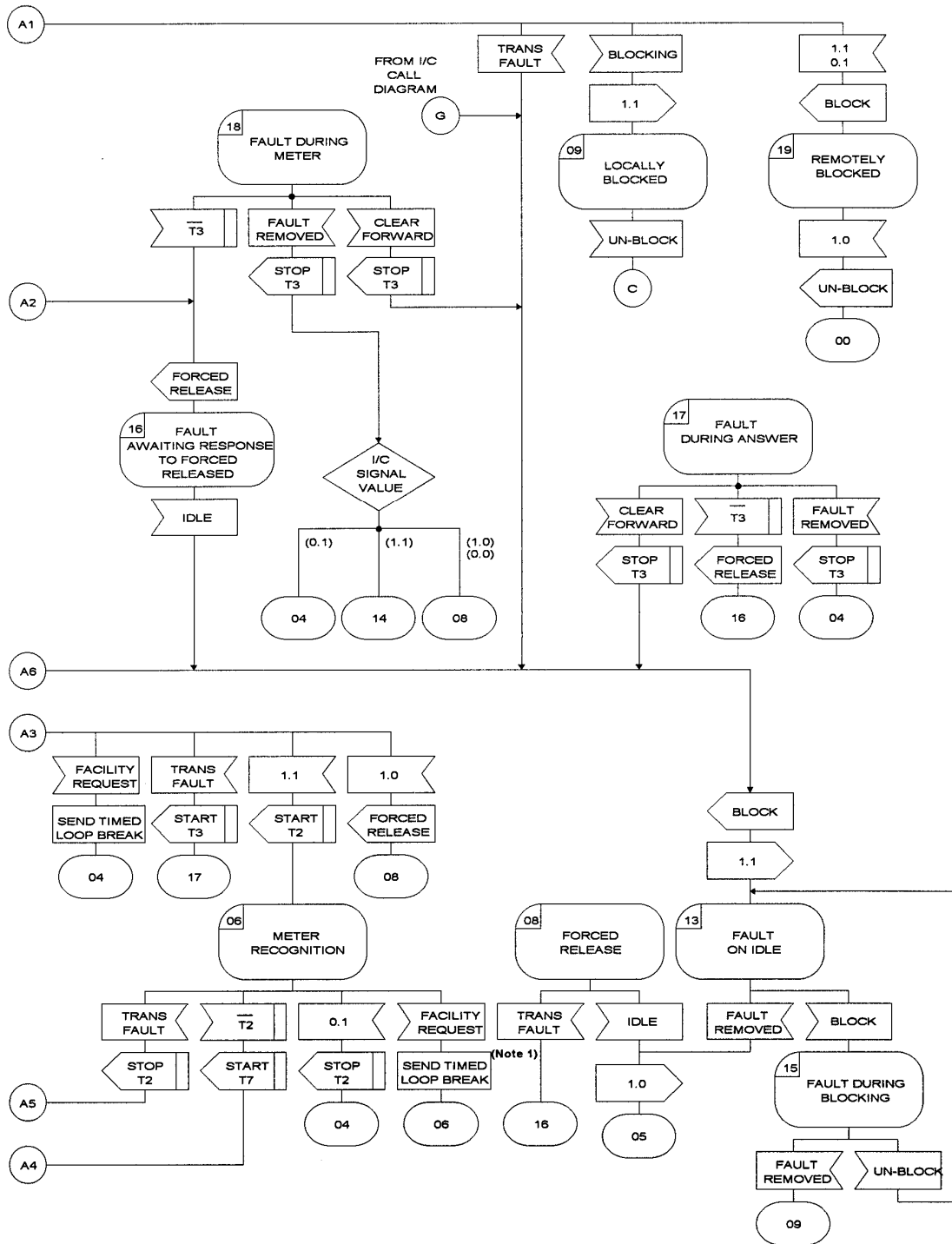
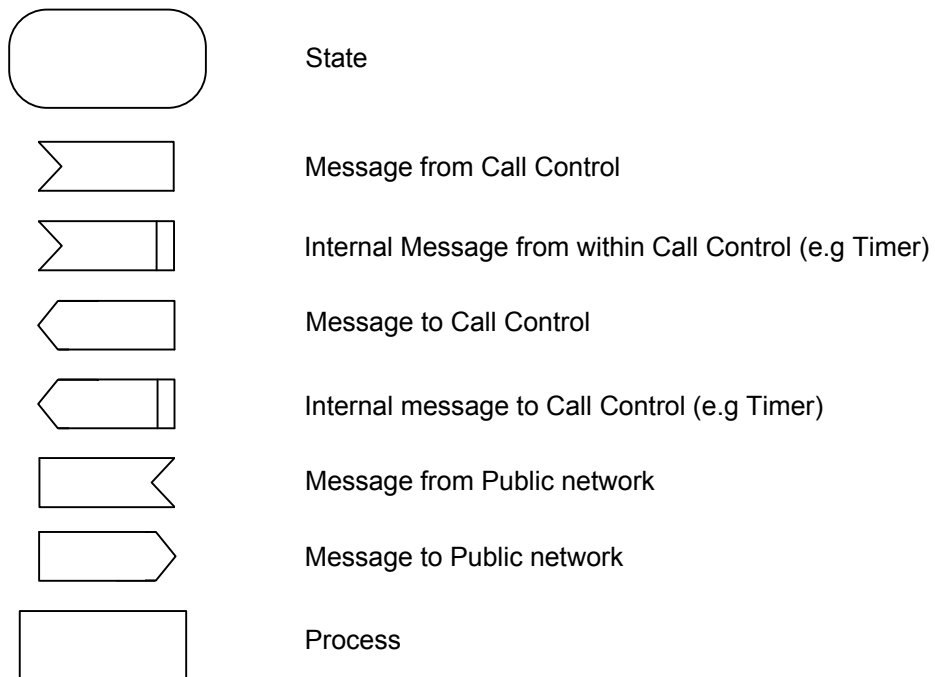

Figure B2

**CAS Line signalling functions – outgoing calls
State and transition diagram (Sheet 2 of 2)**



VALUES

T1	Seize ack time supervision	800 to 2000 ms
T2	Meter recognition – lower limit	90 +0/-10 ms
T3	Delay before clear-down on fault (after answer outgoing end)	6 +/-1 s
T5	Bothway release guard send time	100 +/-20 ms
T6	Send time for timed loop break / facility request	90 +/-10 ms
T7	Meter recognition – upper limit	190 +10/-0 ms

Note: Values include signal validation time, refer C3.1.1.

Figure B3

CAS Line signalling functions – outgoing calls Legend

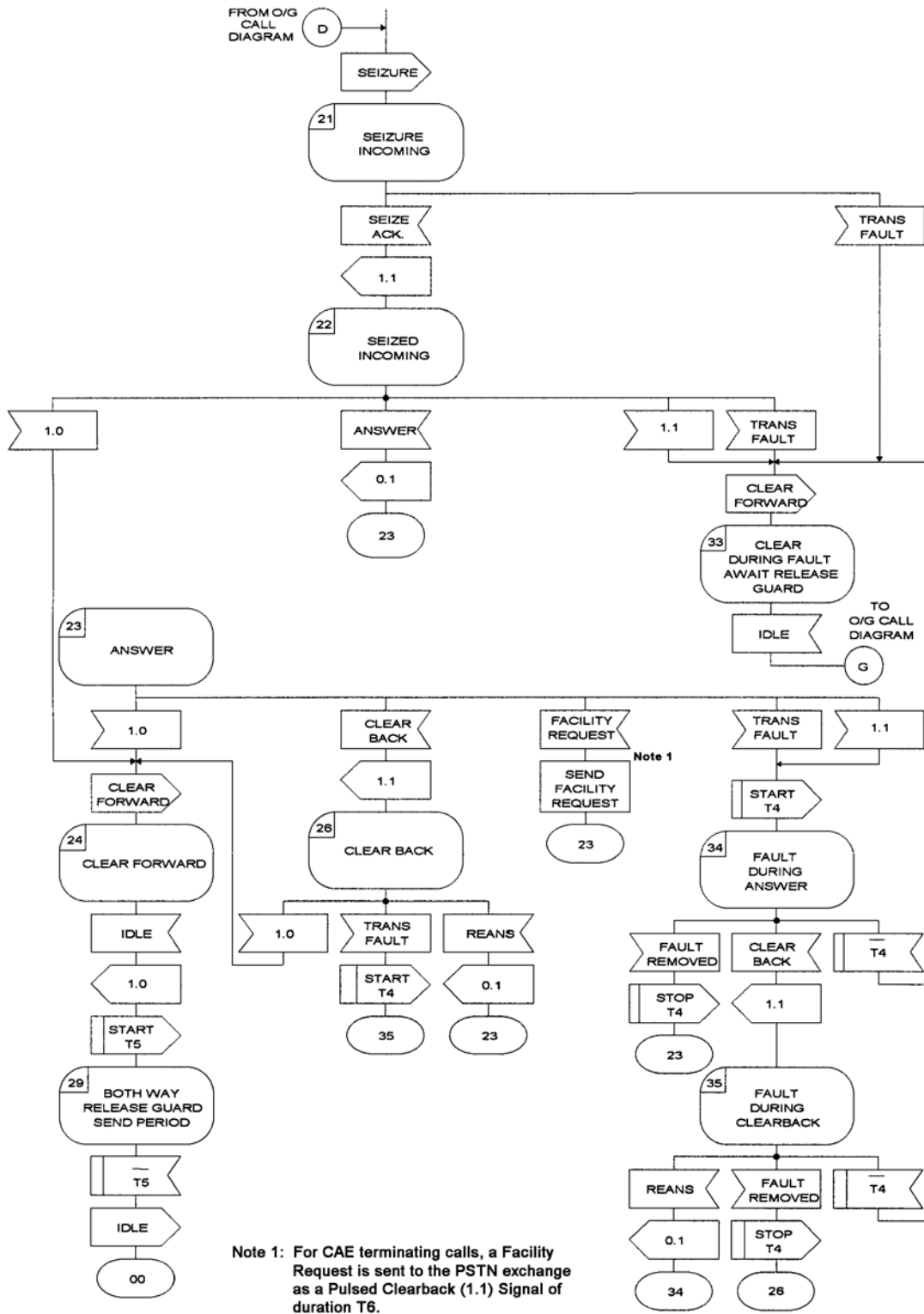
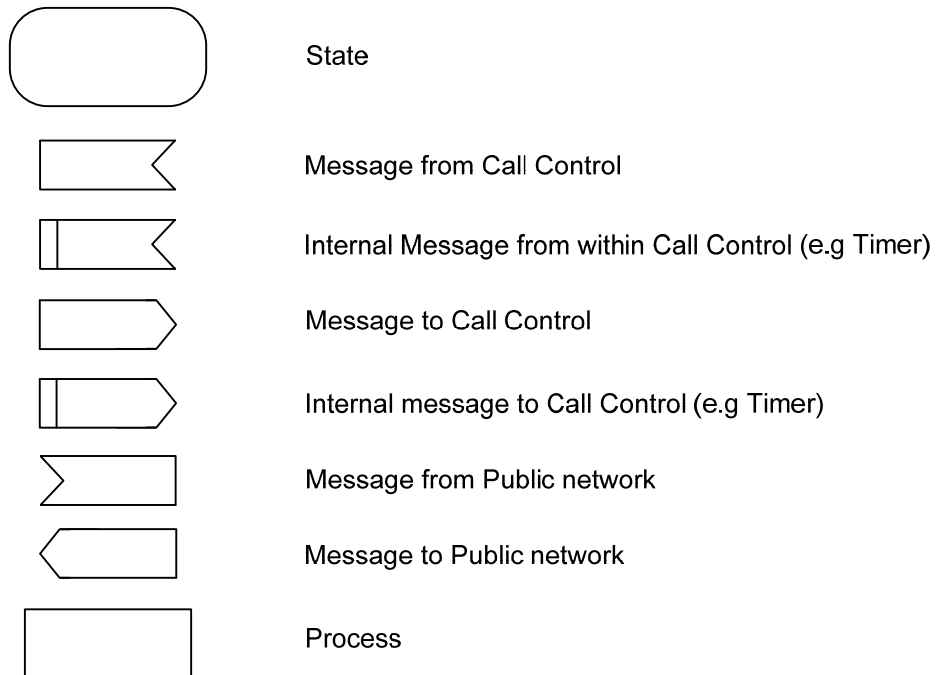

Figure B4

**CAS Line signalling functions – incoming calls
State and transition diagram**



T4	Delay before Cleardown on Fault (After Answer Outgoing End)	7 +/-1 s
T5	Bothway release guard send time	100 +/-20 ms
T6	Send Time for Timed Loop Break / Facility Request	90 +/-10 ms
T7	Meter recognition – upper limit	190 +10/-0 ms

Note 1: Values include Signal Validation Time, refer C3.1.1.

Note 2: For CAE terminating calls a Facility Request is sent to the PSTN Exchange as a pulsed Clearback (1.1) Signal of duration T6.

Figure B5
CAS Line signalling functions – incoming calls Legend

APPENDIX C

C System Integral Terminal Signal Characteristics

C1 General

- C.1.1 This Appendix specifies the requirements for signals produced by System Integral Terminals when connected and confined to customer cabling. This cabling may be within a single building or distributed over multiple buildings within a single customer property. The purpose of these requirements is to allow coexistence of SIT signalling schemes with the various public telecommunications signalling schemes within the same cable sheath.
- C.1.2 Compliance with these requirements does not guarantee compatibility with all the public network schemes in use, but reduces the likelihood of interference with these. In cases where compatibility issues arise, the SIT cabling is to be provided separate from the cable carrying public network services.

C2 Requirements

C.2.1 Signals Limited to the Voice Frequency Range

If CE is designed to deliver signals only in the 300 Hz to 3400 Hz band, the CE is to comply with the following requirements:

- (a) The peak-to-peak signal level transmitted to line **shall not** exceed 5.0 V when measured across a 600 Ω resistive line termination.
- (b) The one-minute mean power level of all signals, other than music and speech, within the frequency range 0.3 kHz to 3.4 kHz **shall not** exceed -10 dBm.
- (c) From 3.4 kHz to 100 kHz the peak signal power level in any 3 kHz band **shall not** exceed the limits shown in Figure C1.
- (d) The power level of individual spectral components of any longitudinal component of the output signals **shall not** exceed the limits shown in Figure C2.

Compliance with Clauses C2.1 (a), (b) and (c) should be checked by using the method described in Clause C3.2.3, using a resistive termination of 600 Ω .

Compliance with Clause C2.1 (d) should be checked by using the method described in Clause C3.2.2, using a resistive termination of 600 Ω .

C.2.2 Signals for Connection to Metallic Cable Pairs

- C.2.2.1 If CE can deliver DC signals, the CE is to comply with the following requirements:

- (a) All DC signals delivered by the CE **shall not** exceed the applicable TNV limits of AS/NZS 60950.1 [4] when measured at the output terminals of the equipment on open circuit.
- (b) When DC signals include polarity reversals, the resulting impulses measured in conjunction with a filter in accordance with ITU-T Rec. O.71 [22] **shall not** exceed a threshold level of -32 dBm.

Compliance with Clause C2.2.1 should be checked by using the methods described in Clause C3.2.1.

C.2.2.2 If CE can deliver low frequency AC signals, i.e. signals below 200 Hz, the CE is to comply with the following requirements:

- (a) All AC signals delivered by the CE up to 100 Hz, including ringing signals, **shall not** exceed the applicable TNV limits of AS/NZS 60950.1 [4]. The normal operating conditions referred to in AS/NZS 60950.1 [4] are to include the open circuit conditions.
- (b) All signals delivered by the CE between 100 Hz and 200 Hz **shall not** exceed 10 V r.m.s. at the output terminals of the equipment on open circuit.
- (c) Levels of noise and distortion products generated by CE **shall** comply with the following:
 - (i) With the exception of ring signals, for all AC signals below 100 Hz, noise and harmonics of the signals **shall not** exceed 774 mV Psophometric when terminated with 600 Ω measured using a device compliant with ITU-T Rec. O.41 [21].
 - (ii) For ring signals, the noise and harmonics of the ring signals **shall not** exceed 774 mV Psophometric when terminated with the following loads:
 - (A) an open circuit; and
 - (B) a 1 μ F capacitor in series with a 4 k Ω resistor.
 - (iii) For all signals between 100 Hz and 200 Hz, the peak power level of noise and distortion products above 3.4 kHz in any 3 kHz band **shall not** exceed the spectral mask shown in Figure C3.
- (d) The power level of individual spectral components of any longitudinal component of the output signals **shall not** exceed the limits shown in Figure C2.
- (e) All AC signals delivered by the CE **shall not** exceed 100 mA under all normal operating conditions.

Compliance with Clauses C2.2.2(a) and (b) should be checked by using a high impedance voltmeter.

Compliance with Clauses C2.2.2(c)(i) and (ii) should be checked by using the method described in Clause C3.2.3 where the voltmeter measurement is psophometrically weighted.

Compliance with Clause C2.2.2(c)(iii) should be checked by oscilloscope measurement with a termination of 600 Ω .

Compliance with Clause C2.2.2 (d) should be checked by using the method described in Clause C3.2.2.

Compliance with Clause C2.2.2 (e) should be checked by using an RMS reading ammeter.

C.2.2.3 If CE can deliver wideband signals in the range 200 Hz to 30 MHz, the CE is to comply with the following requirements:

- (a) The peak-to-peak signal level transmitted to line **shall not** exceed 8 V.
- (b) The one-minute mean power level of:
 - (i) all signals delivered by the CE **shall not** exceed +10 dBm; and
 - (ii) signals within the range 300 Hz to 3.4 kHz **shall not** exceed -10 dBm.
- (c) The power level of individual spectral components of any longitudinal component of the output signals **shall not** exceed the limits shown in Figure C4.

Compliance with Clause C2.2.3 (a) should be checked by measurement with a storage oscilloscope with a minimum effective bandwidth of DC to 100 MHz.

Compliance with Clauses C2.2.3(b)(i) and (ii) should be checked by using the method described in Clause C3.2.4.

Compliance with Clause C2.2.3 (c) should be checked by using the method described in Clause C3.2.2.

C3 Parameters to be Tested

C.3.1 External Stimulus

The limits specified in Clauses C2.1 and C2.2 are the requirements that have to be met in the normal operating modes of the equipment.

In some equipment the power level presented to line is dependent on excitation either internal or external to the equipment. This excitation may be determined from the appropriate product specification or with some equipment this will require the connection of the associated equipment to provide the stimulus.

Compliance with Clauses C2.1 and C2.2 should be checked by performing this excitation then measuring the line signal as described by the appropriate tests.

C.3.2 Methods for external stimulus and excitation of the CE include:

C.3.2.1 Impulse Measurement

Impulses caused by the reversal of DC signals described in Clause 5.2.3.1 can be measured with a standard impulse counter incorporating a filter in accordance with ITU-T Rec. O.71 [22] and having a high impedance (greater than 100 k Ω // 30 pF) bridged across the line.

C.3.2.2 Longitudinal Power Measurement

The equipment under test should be connected to the measuring instrument as shown in Figure C5. A selective measuring set or spectrum analyser having an effective bandwidth sufficiently narrow to measure individual spectral components should be used to explore the frequency band from 200 Hz to 34 MHz and to measure the rms voltage (V) of any spectral component either using the internal calibration or from comparison with a sinusoidal signal of known rms voltage and the same frequency.

C.3.2.3 VF Signal Level Measurement

The power levels specified in Clauses C2.1 and C2.2.2 should be calculated using the formula $V^2/600$. The voltages should be measured across the terminals of the CE using a RMS reading voltmeter with an input impedance greater than 100 k Ω // 30 pF, while the CE is terminated with a resistive load of 600 Ω .

For the one-minute mean power level measurements, the voltmeter should have the following elements:

- (a) An input band-selection filter with passband 300 Hz to 3.4 kHz.
- (b) A square-law detector having a time constant of nominally 100 ms.
- (c)
 - (i) An averaging circuit that performs a continuing averaging process over a period of one minute, i.e., computes the value of:

$$\frac{1}{60} \int_{T_n}^{T_n+60} V^2 dt$$

where:

T_n is time in seconds

V is the RMS voltage indicated by the square-law detector, in Volts.

- (ii) the measurement should be carried out for a sufficient time for the averaging circuit to record a steady value.

For determining the value for Clause C2.1 (c), the input filter centre frequency should be adjustable over the range 4.9 kHz to 98.5 kHz with a passband of 3 kHz.

C.3.2.4 Wideband Signal Power Level Measurement

The power levels specified in Clause C2.2.3 (a) should be calculated using the formula $V^2/120$. The voltages should be measured across the terminals of the CE with a RMS reading voltmeter with an input impedance greater than $100\text{ k}\Omega // 30\text{ pF}$, while the CE is terminated with a resistive load of $120\ \Omega$.

For one-minute mean power level measurements required by Clause C2.2.3 (b), the voltmeter should have the following elements:

- (a) A square-law detector having a time constant of nominally 100 ms,
- (b)
 - (i) An averaging circuit that performs a continuous averaging process over a period of one minute, i.e., computes the value of:

$$1/60 \int_{T_n}^{T_n + 60} V^2 dt$$

where: T_n is time in seconds

V is the RMS voltage indicated by the square-law detector, in Volts.

- (ii) The measurement should be carried out for a sufficient period for the averaging circuit to record a steady value.

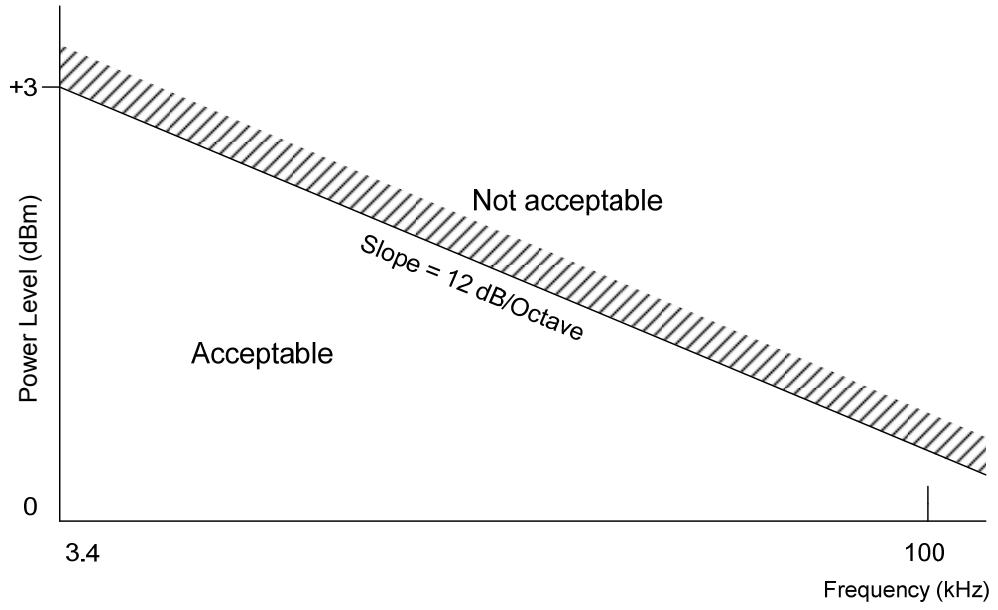

Figure C1
Power Level Limits Above 3.4 kHz

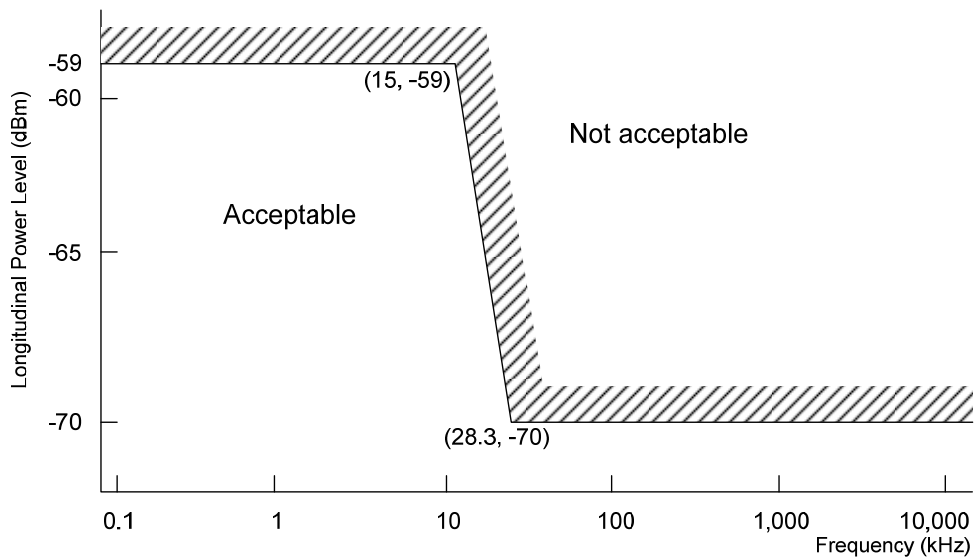

Figure C2
Longitudinal Power Level Limits

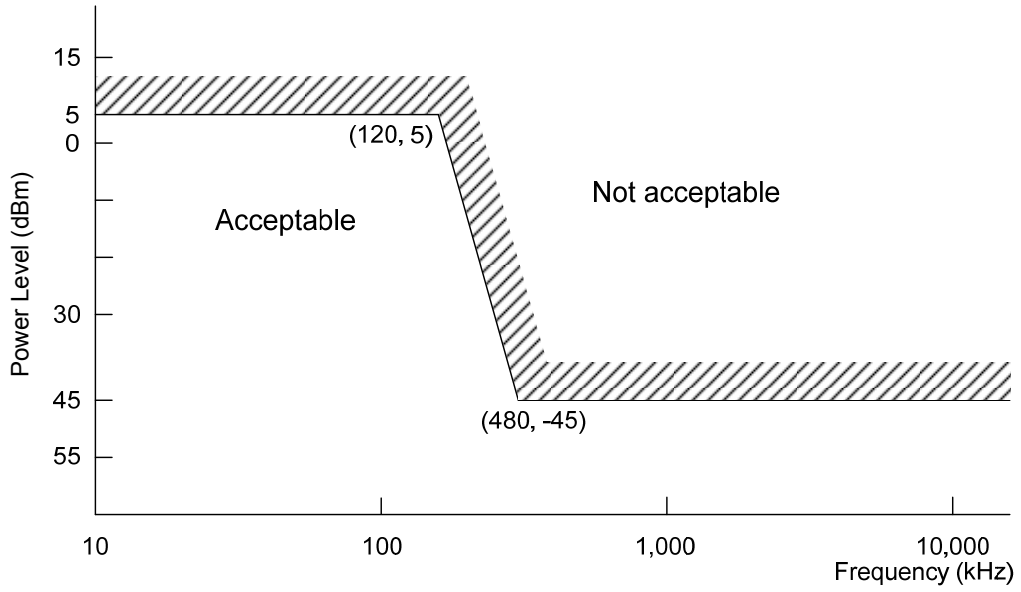

Figure C3
Signal Power Level Limit in any 3 kHz Band

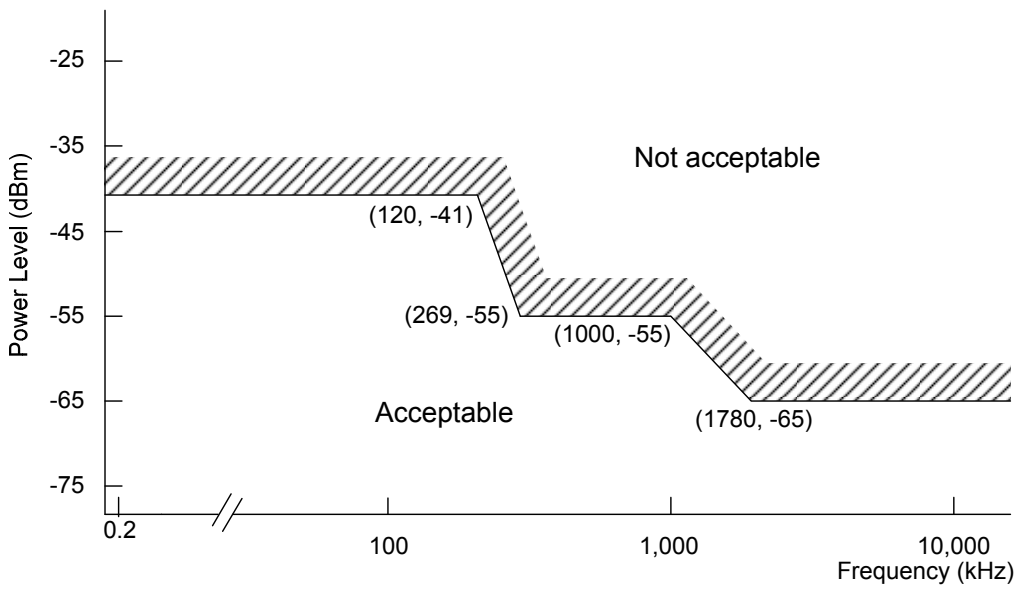
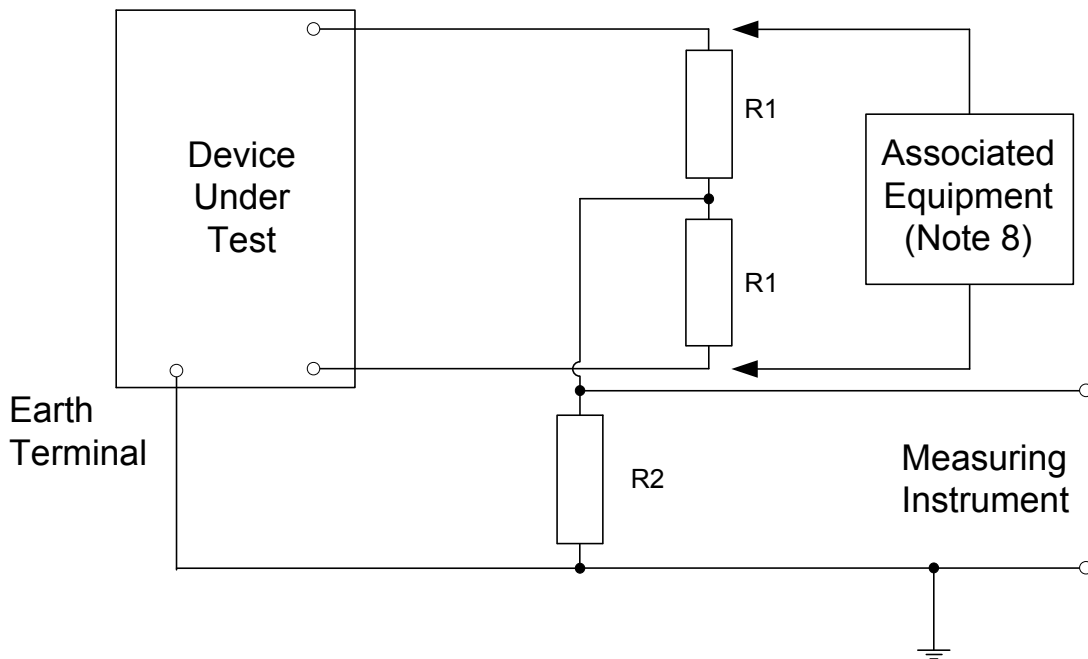

Figure C4
Longitudinal Power Level Limits (Wideband Signals)



Note 1: If the equipment has separate protective and signal earth terminals they are connected together.

Note 2: The two resistors R1 **shall** be matched to within 0.01%.

Note 3: The measuring instrument is of high impedance, and capable of measuring over the frequency range 200 Hz to 30 MHz.

Note 4: The measuring instrument is calibrated in dBm as if it was measuring across a resistive load.

Note 5: The adequacy of the balance is checked by repeating the measurements with appropriate connection reversal, or equipment disconnection.

Note 6: The value of the resistor R1 **shall** be 300 Ω for CE signals with fundamental frequency components in the DC to 3.4 kHz range and 60 Ω for frequency components in the 3.4 kHz to 30 MHz range.

Note 7: The value of the resistors R1 and R2 **shall** be 60 Ω for CE signals with fundamental frequency components in the 3.4 kHz to 30 MHz range when the CE is not being tested with any associated equipment.

Note 8: The value of the resistors R1 and R2 **shall** be 2 k Ω and 60 Ω respectively for CE signals with fundamental frequency components in 3.4 kHz to 30 MHz range when the CE is being tested with any associated equipment.

Note 9: This figure does not show DC decoupling, if required, of the test loads. This must be carefully considered to ensure correct longitudinal power level measurements and correct operation of the CE.

Figure C5

Test Circuit for Measurement of Longitudinal Power Level

APPENDIX D

D Conference bridges

D1 Conference supervision

- D.1.1 The call connection between a participant and the Conference bridge should be released when the party goes off-line, (either automatically or under control of the conference supervisor). Automatic release may be achieved by the detection of service tones (i.e. Busy, Congestion, Dial or Number Unobtainable (NU) tone) at that port.
- D.1.2 When using tone detection, automatic disconnection from the Conference bridge should be achieved within four cycles of Busy tone, two cycles of Congestion tone or three seconds of Dial tone or NU tone being received.
- D.1.3 Nominal impedance
- The requirements for nominal impedance as specified in Clause 5.5.1.4 apply.
- D.1.4 Impedance unbalance to earth
- The requirements for impedance unbalance as specified in Clause 5.4.3 apply.
- D.1.5 Threshold level
- It is recommended that the threshold level be adaptable between -46 dBm and -30 dBm in 1 dB steps.
- D.1.6 Gain/Loss/Automatic Gain Control (AGC)
- D.1.6.1 The gain/loss characteristics of the call connections are at the discretion of the manufacturer. The following characteristics are suggestions only:
- (a) For input less than -21 dBm₀, the amplifiers in the Conference bridge should be designed to incorporate the following characteristics:
- Output = input + gain of 18 dB \pm 1 dB.
- (b) For input equal to -21 dBm₀ or greater:
- Output = -3 dBm₀ (i.e. under AGC) \pm 1 dB.
- D.1.6.2 If the equipment design uses voice switching techniques, for the conditions specified in Clause D.1.6.1, the reverse direction through the device should experience an inverse loss equal to the forward gain (i.e. up to 18 dB) for the time during which the signal in the forward direction has 'captured' the speech detector.

- D.1.6.3 Clause D.1.6.2 describes peak power levels for speech. For performance testing, a sinusoidal signal 3 dB below these levels should be used to avoid the effects of AGC attack and decay.
- Note: Test tones of levels -21 dBm and -23 dBm are used to detect the point at which AGC is activated.
- D.1.7 Automatic gain control attack and decay times
- The attack and decay times are at the discretion of the manufacturer. To cause negligible subjective impairment to speech the following times are suggested:
- (a) Attack
- When in the quiescent state, each Conference bridge port should assume the active state within 5 ms of detecting a signal level which exceeds the input threshold.
- (b) Decay
- Each Conference bridge port should revert to the quiescent state from the active state when the signal level appearing at the port is less than the input threshold for durations longer than 100 ms.
- D.1.8 Loss Distortion with Frequency
- The requirements for Loss distortion with frequency are specified in Clause 5.2.3 of ETSI ES 201 168 [23].
- D.1.9 Stability
- The conference bridge should be unconditionally stable for all input levels and with all input/output ports terminated in any impedance of any phase angle.
- D.1.10 Total distortion
- The requirements for total distortion are specified in Clause 5.6 of ETSI ES 201 168 [23].
- D.1.11 Noise performance
- The requirements for noise performance of any test call connection through the Conference bridge, with all ports active and terminated in 600 Ω and strapped for maximum gain, should be as specified in Clause 5.4 of ETSI ES 201 168 [23] but relaxed by a value of 3 dB.
- D.1.12 Crosstalk
- Between separately established conferences, the requirements for crosstalk performance are specified in Clause 5.5 of ETSI ES 201 168 [23].

APPENDIX E

E CAE Terminology

E1 General

E.1.1 This Appendix provides a summary of the port terminology in a diagrammatic and tabular form. Table E1 also provides a comparison of port designations with those used in Europe and North America.

E2 Digital Network Interfaces

E.2.1 Digital Network Interfaces can carry narrowband or broadband signals and are not technology specific within this Standard. Refer to definition in Clause 4.2.16.

E.2.2 Interfaces for Network Port (Digital) are technology independent and can be electrical, optical or wireless. Refer to definition in Clause 4.2.30.

E.2.3 WAN Ports are considered to be a subset of Network Port (Digital).

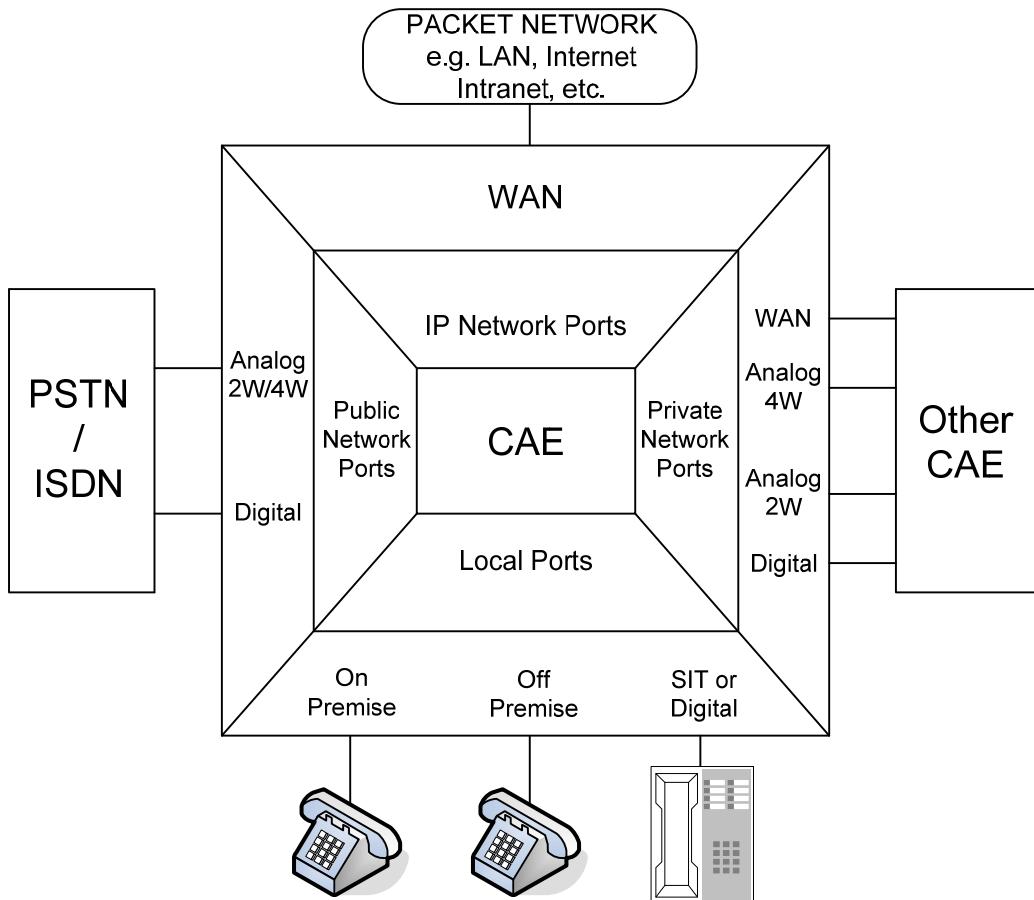

Figure E1
CAE connections

Table E1
Terminology Cross-reference Table

AS/CA S003:2010	AS/ACIF S003: editions prior to AS/CA S003:2010	Europe ETSI	North America ANSI
Customer Equipment (CE)	CE		
Customer Access Equipment (CAE)	Customer Switching System (CSS)	Voice Gateway / PBX	Voice Gateway / PBX
Network Port (Ring/Loop)	Exchange line	K2	FXO / COT
Local Port (On Premises)	Extension Line	L21	ONS/ FXS
Local Port (Off Premises)	External Extension	L22	OPS/ FXS
Local Port (Digital)	System Integral Equipment	LD / MS	DGS
Network Port WAN	-----	WAN	WAN / PAL
Network Port (Digital)	Digital Exchange line / Digital Tie Line / ISDN	KD / MD	DAL
Network Port 2W Analogue	2 wire Exchange Line or Tie Line	K2 M2	FXO / COT ATT
Network Port 4W Analogue	4 wire Exchange Line or Tie Line	M4	ATT
Integrated Access Device (IAD)	-----	IAD	IAD / MTA
System Integral Terminal (SIT)	Industry Based Proprietary Terminal (IBPT)	System Specific Telephony Terminal	System Station / Digital Proprietary Terminal

Note: WAN Ports are considered to be a subset of Network Port (Digital). Interfaces for Network Port (Digital) are technology independent and can be electrical, optical or wireless. Refer to definition in Clause 4.2.30.

PARTICIPANTS

The Working Committee that developed this Standard consisted of the following organisations:

Organisation	Membership
ACMA	Non-Voting
Comtest Laboratories	Voting
NEC	Voting
Optus	Voting
Telstra	Voting
Testing & Certification Australia	Voting
Thompson Telecom Australia	Voting
Trillium Communications	Voting

This Working Committee was chaired by Laurie Collier. Mike Johns of Communications Alliance Ltd provided project management support.

Communications Alliance was formed in 2006 to provide a unified voice for the Australian communications industry and to lead it into the next generation of converging networks, technologies and services.

In pursuing its goals, Communications Alliance offers a forum for the industry to make coherent and constructive contributions to policy development and debate.

Communications Alliance seeks to facilitate open, effective and ethical competition between service providers while ensuring efficient, safe operation of networks, the provision of innovative services and the enhancement of consumer outcomes.

It is committed to the achievement of the policy objective of the *Telecommunications Act 1997* - the greatest practicable use of industry self-regulation without imposing undue financial and administrative burdens on industry.



Published by:
**COMMUNICATIONS
ALLIANCE LTD**

Level 9
32 Walker Street
North Sydney
NSW 2060 Australia

PO Box 444
Milsons Point
NSW 1565

T 61 2 9959 9111
F 61 2 9954 6136
TTY 61 2 9923 1911
E info@commsalliance.com.au
www.commsalliance.com.au
ABN 56 078 026 507

Care should be taken to ensure the material used is from the current version of the Standard or Industry Code and that it is updated whenever the Standard or Code is amended or revised. The number and date of the Standard or Code should therefore be clearly identified. If in doubt please contact Communications Alliance

ISBN: 1 74000 394 2