



SCANIA K-SERIES

Great buses and coaches start here





SCANIA K-SERIES



Great buses and coaches, from the ground up

Take a close look at the chassis. It's a crucial foundation. By building on Scania quality, it's easy to turn the rest of your vehicle into a successful long-term investment.

Our engines, transmissions and chassis components are legendary for their reliability and impressive service life. This means outstanding fuel economy, lower emissions and more uptime for your finished vehicle. Add to that a range of driver support systems, and your Scania will provide great satisfaction for many years to come.





Exceptional driveability for instant driver appeal

The harmonious interaction between the driver, the vehicle and the road is a key factor for your success. It's all made possible by the smart layout of our driver stations, featuring integrated ergonomic design and logically positioned controls to ensure safe, relaxed, and economical operation.

Furthermore, your drivers will enjoy Scania's unique response and torque, the smooth power flow and traction. It's the careful balance of these properties that makes a truly great bus or coach a pleasure to drive.



A well-designed driver station On the ergonomically improved, moulded plastic dashboard, all buttons and controls are logically placed and fitted into a smoothly functioning entity.



Multi-functional steering wheel Fully adjustable and equipped with built-in commands, the steering wheel enables complete control of the on-board computer as well as the cruise and down-hill speed controls via the combined Scania Opticruise and Retarder lever.



Pendant pedals Ergonomic pendant pedals activate the correct leg muscles for safer and more comfortable driving, even after many hours on the road.



Award winning engines – fuel economy with environmental performance

Improved fuel economy depends on the optimised interaction between driver, vehicle and service. And since fuel is a primary operating expense, your choice of engine and chassis components are crucial to profits. The Scania 7-, 9- and 13-litre engines are part of Scania's industry-leading platform of modular power plants.

Power with emission control

The Scania engine range covers emission levels Euro 3 to Euro 6 and all commercially available fuel options. Focus lies on optimised emission control paired with efficient performance, such as excellent starting power and acceleration for exceptional driveability in challenging road and traffic conditions.

Perfectly matched components and services

All Scania engines have plenty of torque and a perfectly matched transmission. The air-processing system and gearboxes complement our engines to help achieve the lowest possible fuel consumption, backed up by built-in systems:

- Scania Driver Support – real-time suggestions and feedback to the driver
- Scania Active Prediction – uses GPS to analyse the topography of the road ahead for optimising speed and choice of gear.

In addition, there is a range of Scania Services available, making the most of both fleet and driver:

- Scania Driver Training
- Scania Driver Coaching – personal follow-up
- Scania FMS (Fleet Management Systems) – for continuous follow-up of the entire fleet.



Service – our total commitment

Knowing that you can turn to Scania for true one-stop-shopping for all your service, brings peace of mind.

With a comprehensive global network of more than 20,000 trained professionals, we are ready to assist you. Our total operational focus with maintenance and repair contracts along with high availability of parts, constitute the foundation for secured uptime and reduced life cycle costs. Our workshop services include Scania Maintenance, Scania Repair, Scania Assistance, Scania Service Exchange, and Scania Parts.

So, if you're looking for a 100% commitment, Scania is the ideal choice for a long-term partner offering a complete operational approach.



The charge air cooler conveniently swings upward to provide full access and greater ease of maintenance.



Imagine your bus or coach: Your wishes become our specs

The flexibility of the Scania K-series enables you to build a wide variety of bus or coach types with varying floor heights and driver positions. Every solution is characterised by the same high level of comfort, reliability, and safety.

Safe, powerful braking

The Scania K-series comes with electronically controlled disc brakes or drum brakes with electronic or pneumatic brake control.

All our engines offer powerful exhaust braking. Together with Scania's integrated hydraulic Retarder you get a dependable and predictable braking system for all situations. The Scania Retarder boosts safety levels – in part by preventing brake fade on long downhill gradients – while simultaneously reducing wear on the wheel brakes.

The real-time support systems further help to keep an extra eye on safety. For example, the Scania LDW (Lane Departure Warning) warns the driver if the vehicle unintentionally crosses lane markings on the road. At the risk of collision the Scania AEB (Advanced Emergency Braking) uses visual and sound alarms to alert the driver and activates the emergency brake system when needed.

Comfortable, stable suspension

The Scania K-series air suspension is controlled electronically. The vehicle level can be rapidly adjusted to compensate for rough pavement. This ensures a level of safety, stability and comfort that surpasses all expectations.



Perfect base for your city bus.

The K-series with its lowered front axle allows a low floor area for smoother passenger flows in city and suburban operations. The 7- and 9-litre engines come with a 6-speed automatic transmission. The 9-litre engine also has additional options; 8- or 12-speed fully automated Scania Opticruise gearbox, or 7-speed Scania Comfort Shift.

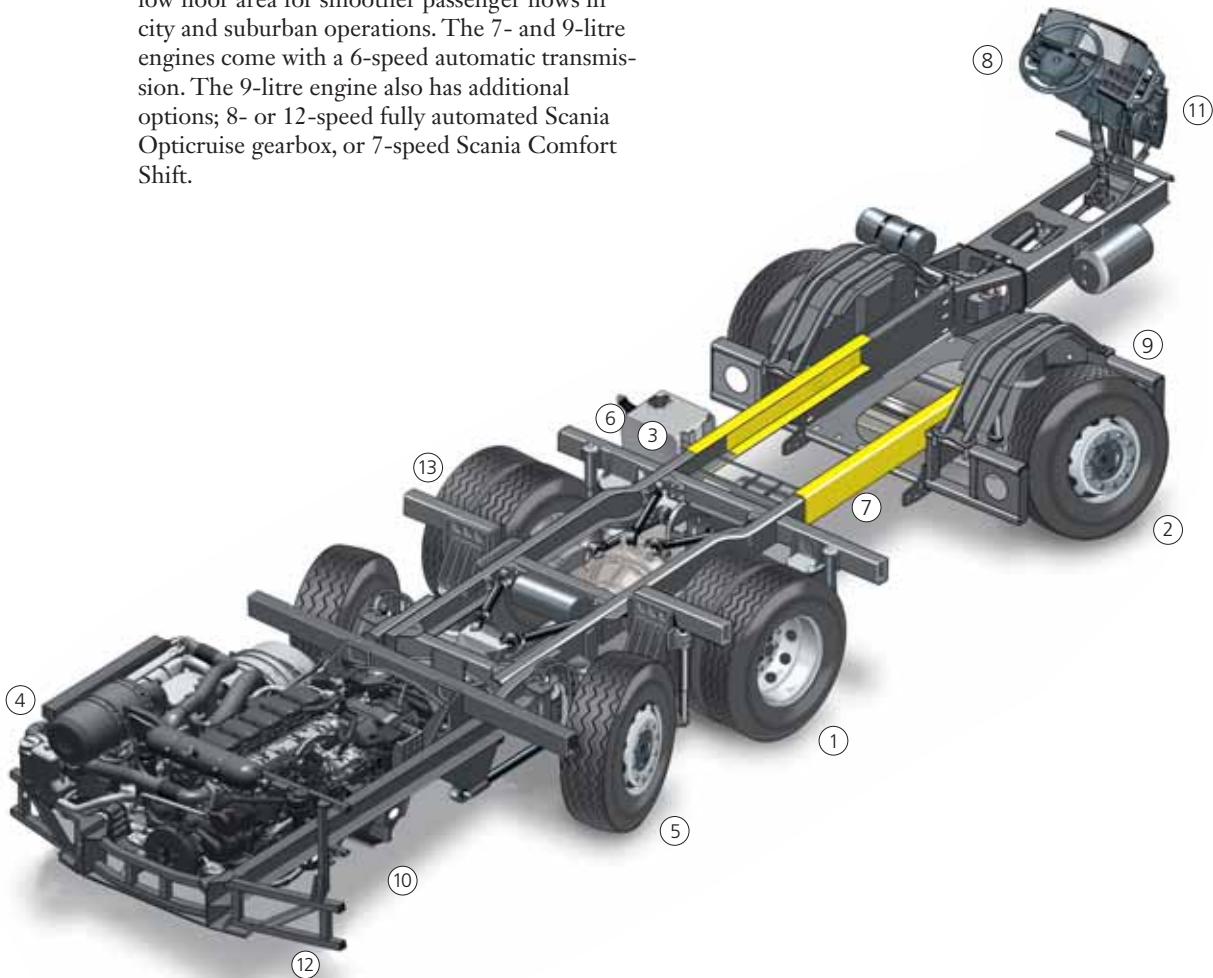

- ① The latest developments in precision braking are included in the Scania Electronic Braking System (EBS), including Emergency brake.
- ② In addition to the EBS, the K-series also features disc or drum brakes.
- ③ The Air-Processing System (APS) is an intelligent processing solution that efficiently manages use of air and loading to help reduce fuel consumption. APS includes an air dryer for enhanced reliability and longer service life for braking system components.
- ④ A hydraulically driven fan assures controlled fan speed, which reduces noise and improves fuel economy.
- ⑤ The hydraulically steered tag axle increases manoeuvrability, thus allowing the use of a longer bus in tight areas. Rear steering also reduces tyre wear on the tag axle.
- ⑥ For Euro 4 and 5, the reductant tank in stainless steel is located on the left or right side, for easy access. The Euro 6 version comes with a plastic tank and a more flexible placement option.
- ⑦ Also available as articulated chassis.
- ⑧ The Scania Diagnos enables easy troubleshooting of the entire vehicle. The electrical system also provides great flexibility for the bodybuilder to add extra functions.
- ⑨ The design of the outriggers, cross members and side members provides a stiff chassis for optimum stability. Air suspension and electronic level control offer exceptional comfort for passengers.
- ⑩ The free space behind the right rear wheel makes room for additional luggage capacity or a rear door.
- ⑪ Driver station with a combined lever for Scania Opticruise and Retarder, functionality in the instrument cluster, pendant pedals, adjustable steering wheel and much more. The K-series with lowered front axle are available with adjustable dashboard, corresponding to the settings of the steering wheel.
- ⑫ The chassis and engine are well prepared for the installation of an air conditioning unit.
- ⑬ The Electronic Stability Program (ESP) is an advanced active safety system that drastically reduces the risk of oversteering, understeering and tipping.

Versatile base for city to intercity buses.

The K-series with a rigid front axle is typically used for intercity and rural applications. The 9- and 13-litre engines, all based on Scania's modular combustion concept, are available with 8- or 12-speed fully automated Scania Opticruise gearbox, 7-speed Scania Comfort Shift, or 6-speed automatic transmissions.

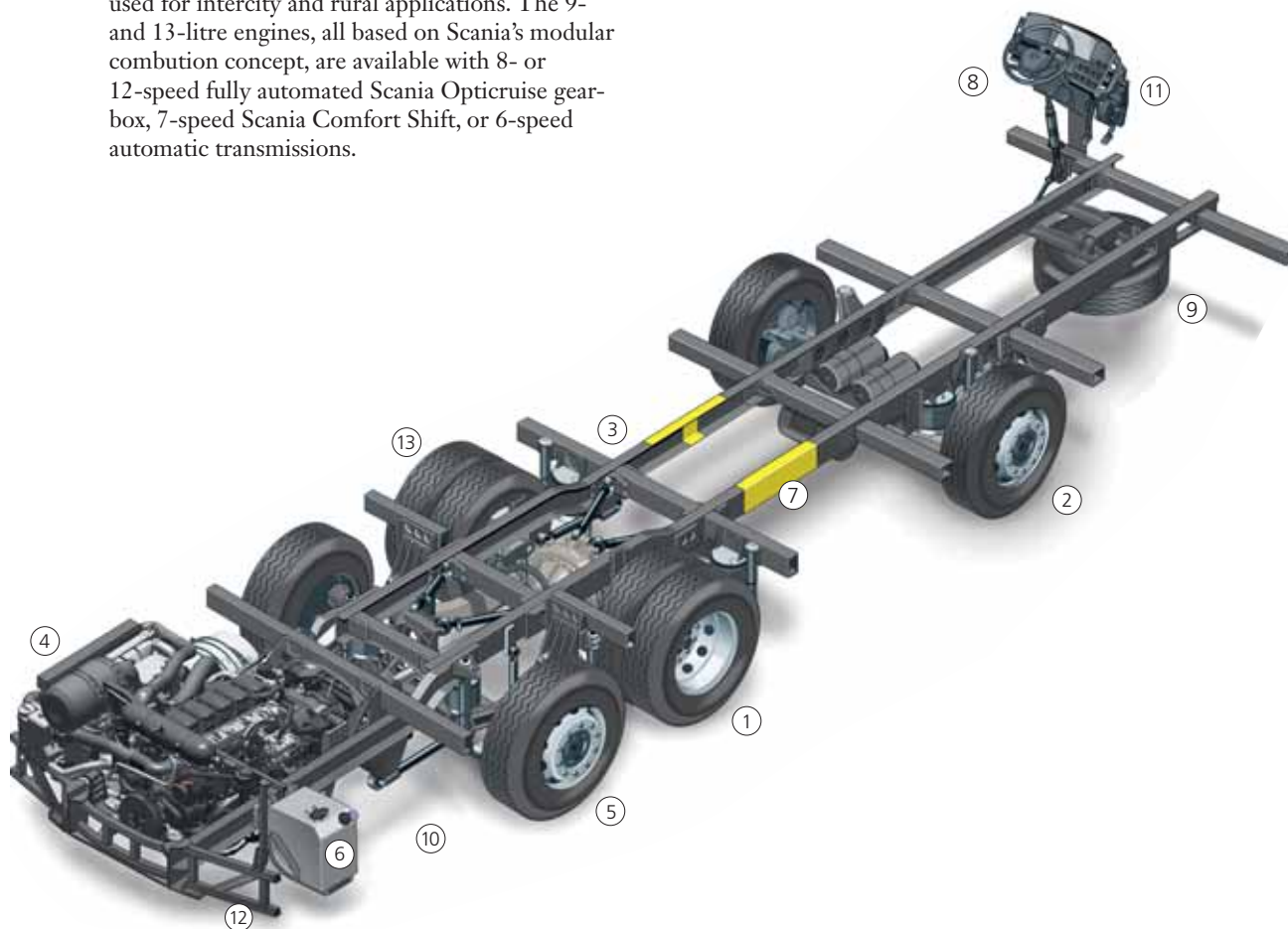

- ① The latest developments in precision braking are included in the Scania Electronic Braking System (EBS), including Emergency brake.
- ② In addition to the EBS, the K-series also features disc or drum brakes.
- ③ The Air-Processing System (APS) is an intelligent processing solution that efficiently manages use of air and loading to help reduce fuel consumption. APS includes an air dryer for enhanced reliability and longer service life for braking system components.
- ④ A hydraulically driven fan assures controlled fan speed, which reduces noise and improves fuel economy.
- ⑤ The hydraulically steered tag axle increases manoeuvrability, thus allowing the use of a longer bus in tight areas. Rear steering also reduces tyre wear on the tag axle.
- ⑥ For Euro 4 and 5, the reductant tank in stainless steel is located on the left or right side, for easy access. The Euro 6 version comes with a plastic tank and a more flexible placement option.
- ⑦ Also available as articulated chassis.
- ⑧ The Scania Diagnos enables easy troubleshooting of the entire vehicle. The electrical system also provides great flexibility for the bodybuilder to add extra functions.
- ⑨ The design of the outriggers, cross members and side members provides a stiff chassis for optimum stability. Air suspension and electronic level control offer exceptional comfort for passengers.
- ⑩ The free space behind the right rear wheel makes room for a toilet, additional luggage capacity or a rear door. In the three-axle configuration, it is possible to add an extra all-through luggage area above the rear axles.
- ⑪ Driver station with a combined lever for Scania Opticruise and Retarder, functionality in the instrument cluster, pendant pedals, adjustable steering wheel and much more.
- ⑫ The chassis and engine are well prepared for the installation of an air conditioning unit.
- ⑬ The Electronic Stability Program (ESP) is an advanced active safety system that drastically reduces the risk of oversteering, understeering and tipping.



For comfortable touring operations.

The K-series with an independent front suspension ensures optimal comfort, superb road handling and a stable ride. The 9- and 13-litre engines, all based on Scania's modular combustion concept, are available with 8- or 12-speed fully automated Scania Opticruise gearbox, 7-speed Scania Comfort Shift, or 6-speed automatic transmissions.

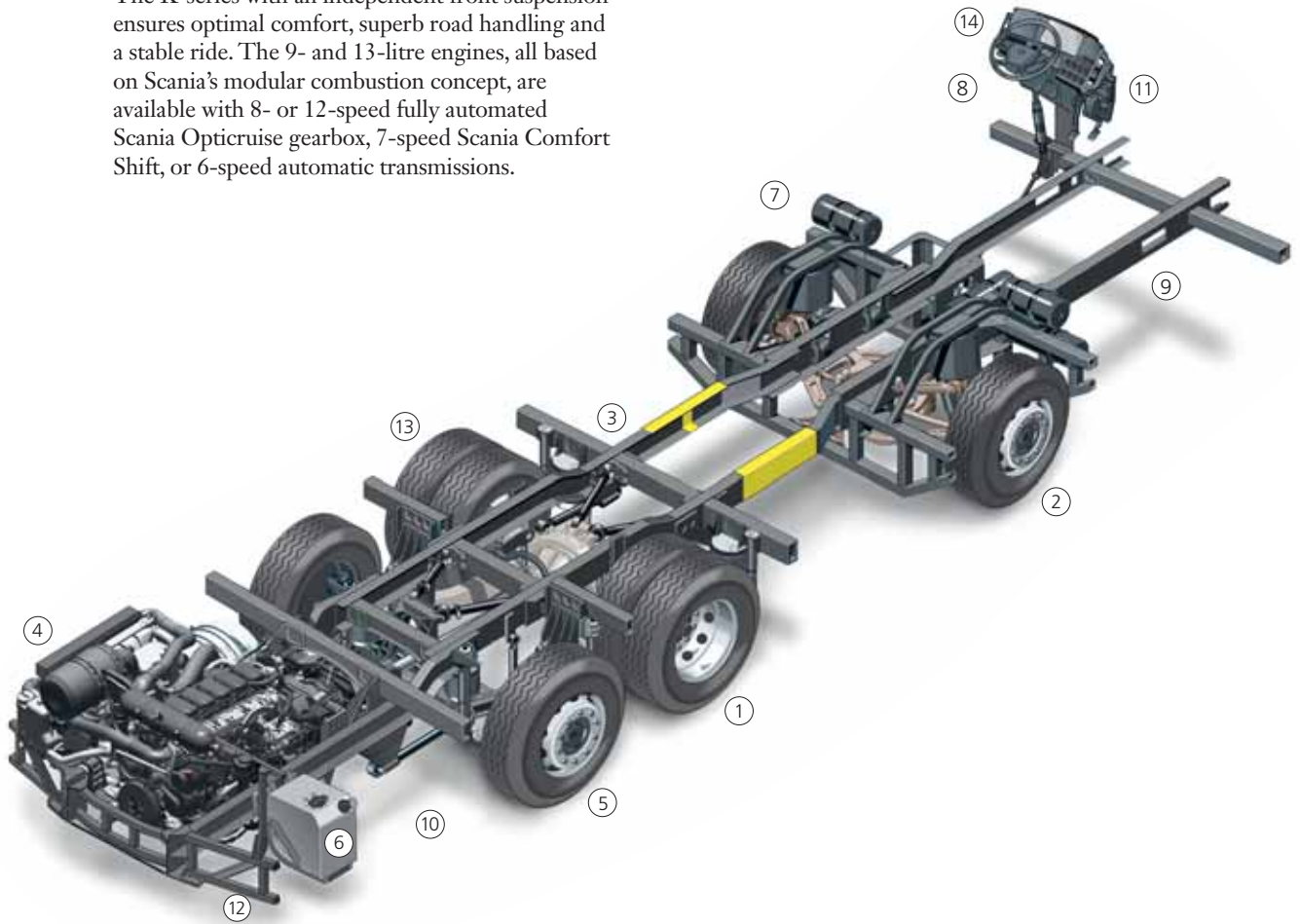

- ① The latest developments in precision braking are included in the Scania Electronic Braking System (EBS), including Emergency brake.
- ② In addition to the EBS, the K-series also features disc or drum brakes.
- ③ The Air-Processing System (APS) is an intelligent processing solution that efficiently manages use of air and loading to help reduce fuel consumption. APS includes an air dryer for enhanced reliability and longer service life for braking system components.
- ④ A hydraulically driven fan assures controlled fan speed, which reduces noise and improves fuel economy.
- ⑤ The hydraulically steered tag axle increases manoeuvrability, thus allowing the use of a longer bus in tight areas. Rear steering also reduces tyre wear on the tag axle.
- ⑥ For Euro 4 and 5, the reductant tank in stainless steel is located on the left or right side, for easy access. The Euro 6 version comes with a plastic tank and a more flexible placement option.
- ⑦ On double-decker coaches, the independent front suspension leaves plenty of space for a generously dimensioned aisle between the front wheel housings.
- ⑧ The Scania Diagnos enables easy troubleshooting of the entire vehicle. The electrical system also provides great flexibility for the bodybuilder to add extra functions.
- ⑨ The design of the outriggers, cross members and side members provides a stiff chassis for optimum stability. Air suspension and electronic level control offer exceptional comfort for passengers.
- ⑩ The free space behind the right rear wheel makes room for a toilet, additional luggage capacity or a rear door. In the three-axle configuration, it is possible to add an extra all-through luggage area above the rear axles.
- ⑪ Driver station with a combined lever for Scania Opticruise and Retarder, functionality in the instrument cluster, pendant pedals, adjustable steering wheel and much more.
- ⑫ The chassis and engine are well prepared for the installation of an air conditioning unit.
- ⑬ The Electronic Stability Program (ESP) is an advanced active safety system that drastically reduces the risk of oversteering, understeering and tipping.
- ⑭ The optimal low driver position for overdeckers and double-deckers eliminates the need for any adaptation by the bodybuilder.

Lowered rigid front axle

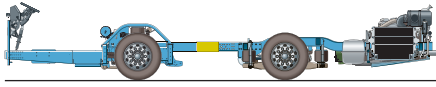

K UB 4x2

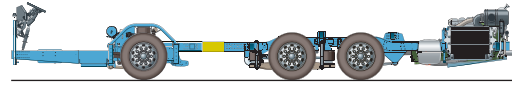

K UB 6x2*4

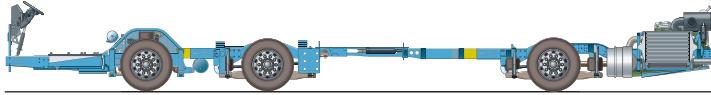

K UA 6x2/2

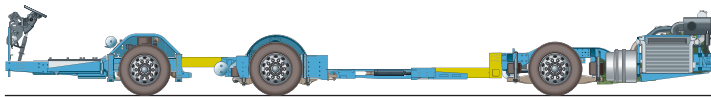

K UA 6x2/2 (low middle axle)

Rigid front axle

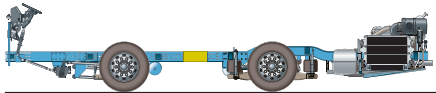

K IB 4x2

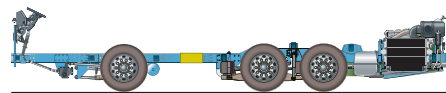

K IB 6x2

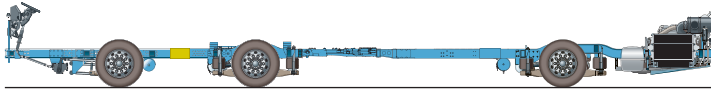

K IA 6x2/2

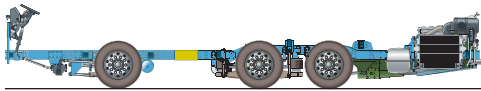

K IB 6x2*4

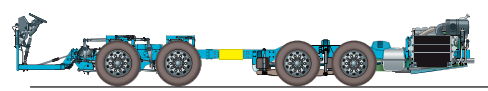

K IB 8x2

Independent front suspension

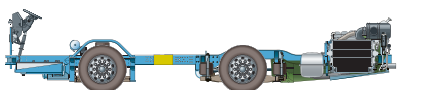

K EB 4x2

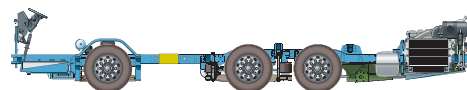

K EB 6x2*4

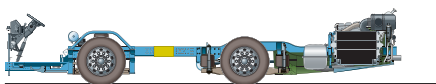

K EB 4x2 (low driver position)

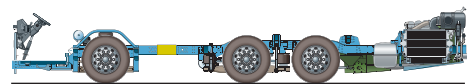

K EB 6x2*4 (low driver position)

Scania pursues an active policy of product development and improvement. For this reason, Scania reserves the right to make changes relating to design and specification, its products and services and any information, without prior notice. Furthermore, due to national or EU legal requirements, some products and services may not be available in all markets.

For more information in these respects, please contact your local dealer or visit www.scania.com.



Edition 2014.09 en-XX2375204 © Scania CV AB 2014

