

Pneumatic Control Box Manual

This Manual contains information of the Techman Robot product series (hereinafter referred to as the TM Robot). The information contained herein is the property of Omron Corporation (hereinafter referred to as the Corporation) and Techman Robot Inc. No part of this publication may be reproduced or copied in any way, shape or form without prior authorization from the Corporation. No information contained herein shall be considered an offer or commitment. It may be subject to change without notice. This Manual will be reviewed periodically. The Corporation will not be liable for any error or omission.

TM logo is the registered trademark of TECHMAN ROBOT INC. and the company reserves the ownership of this manual and its copy and its copyrights.

Contents

Revision History Table	4
1. TM Hardware Kit	5
2. Installation	6
3. Pressure Sensor Setting.....	12
4. KILEWS Accessories.....	14
Appendix A TM Robot Control Box HW 3.0 Wires Assignment.....	15
Appendix B Terminal Block Description	16

Revision History Table

Revision	Date	Revised Content
01	October, 2018	Original Release

1. TM Hardware Kit

The Hardware Kit of the Pneumatic Control Box has the following contents.



Pneumatic Control Box



Ø6 Air Tube



Ø8 Air Tube
(metal in one end)



Bracket



Air Conditioning Valve

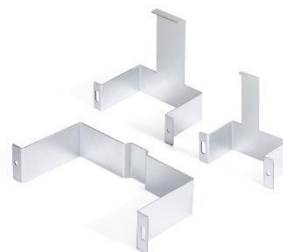

For KILEWS
Stamped Parts



Bracket Screws
onto Robot Stand
(M8x10L) x4



Air Conditioning
Valve Screws
(M4x6L) x2



KILEWS Control
Box Screws
(6-32x6L) x6



Bracket Screws
onto Pneumatic
Control Box
(M4x8L) x4

2. Installation

Step 1 Pneumatic Control Box with Robot Stand

It is recommended to attach the TM Pneumatic Control Box on to the TM Robot Stand. The user can also skip this step if there is no robot stand.

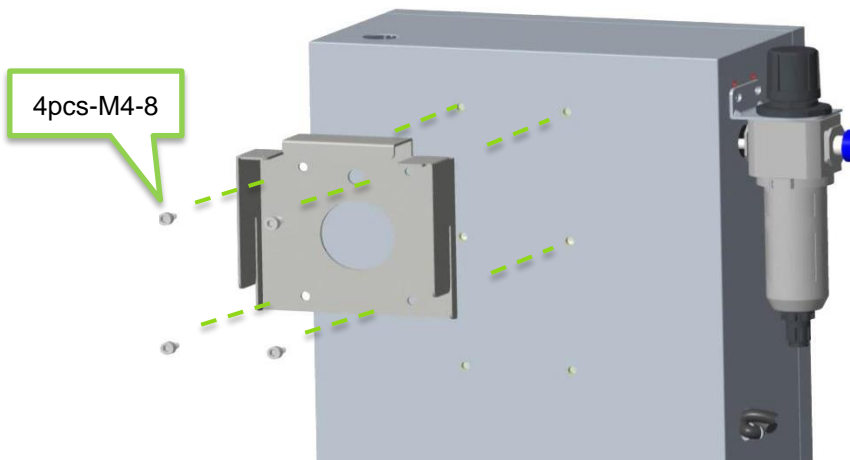

Screw the bracket onto Pneumatic control box (back)

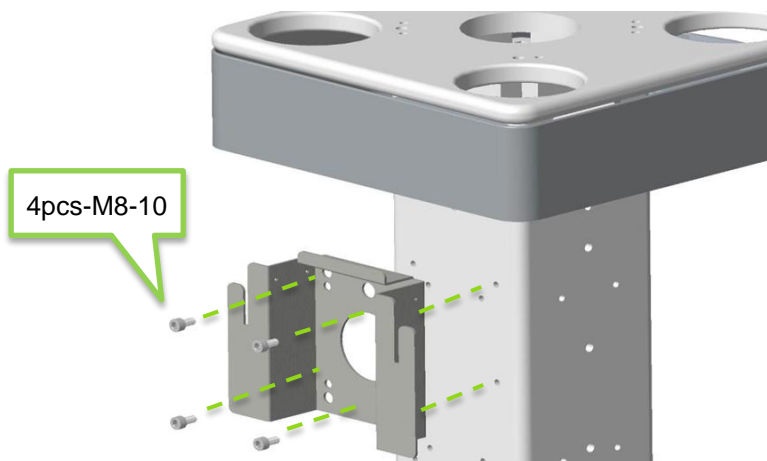

Screw another bracket onto Robot Stand

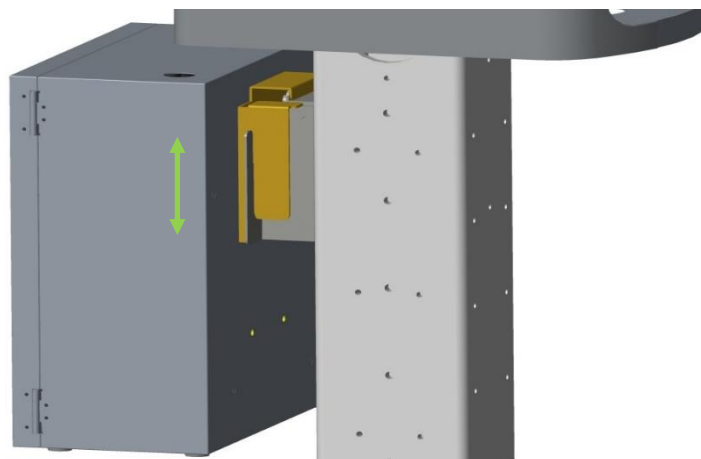

Sliding for installation

Step 2 Detach parts from pneumatic control box

Detach the stamped parts from the pneumatic control box as shown on the right view of the following figure.

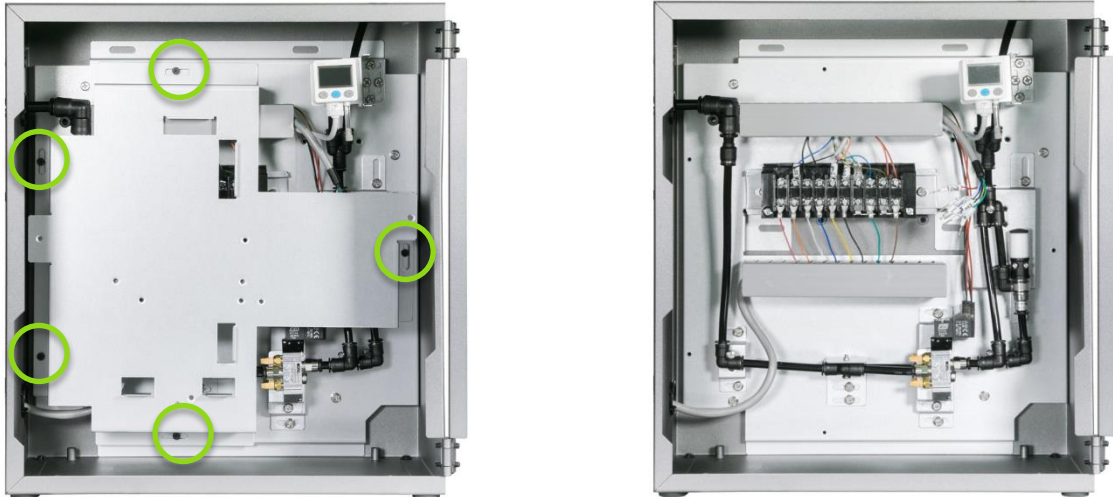

Step 3 Terminal Block

There are 20 ports on the terminal block. Thus, 10 groups can be defined so that the ports on each group are short, or mutually conducted. On the other hand, two terminal jumpers are factory installed. A jumper between port 11 and 12 make group 1 and 2 short with each other (circled in green on the figure). Same applies for group 3, 4 and 13, 14. Users shall check the conduction status of each group using a multimeter. For this example shown in the figure, port 1 and 11 are short with each other. Port 2 and 11 should also be short. Please refer to Appendix B for detailed circuit diagram of the terminal block.

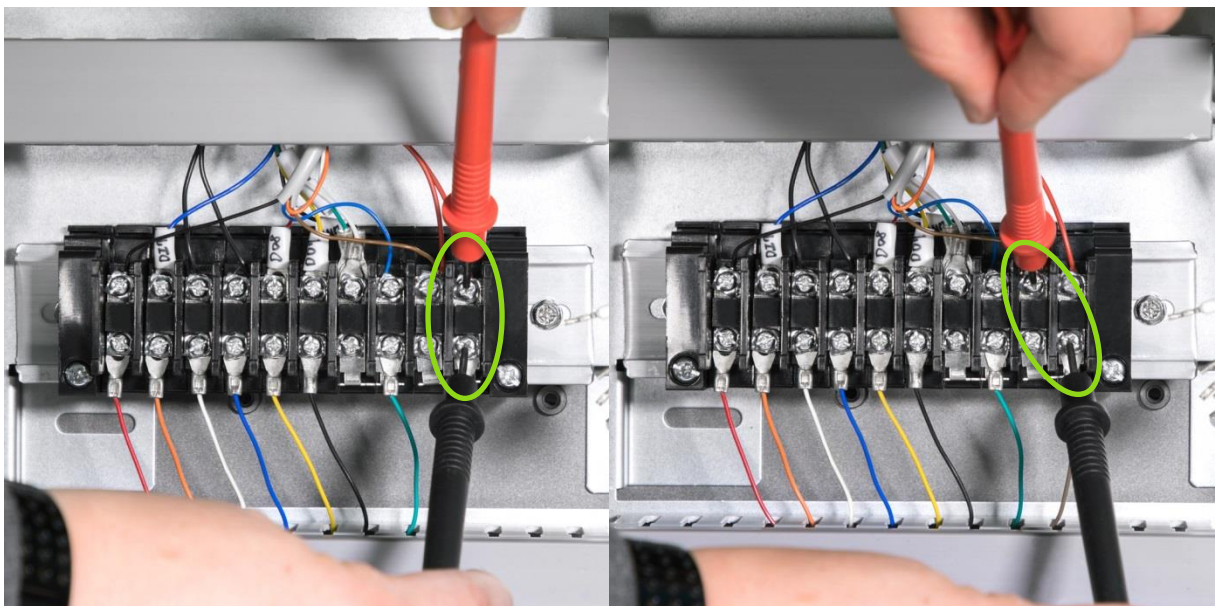

Step 4 Connect TM Robot Control Box

After confirming that the wiring of the terminal block is correct, re-assemble the stamping part in the pneumatic control box, and then plug the 8-channels wires based on the below colour indication into the TM Robot Control Box. Moreover, please refer to the manual of TM Plug&Play KILEWS Screwing Installation for the usage of 6-channels wire, connecting with KILEWS's control box.

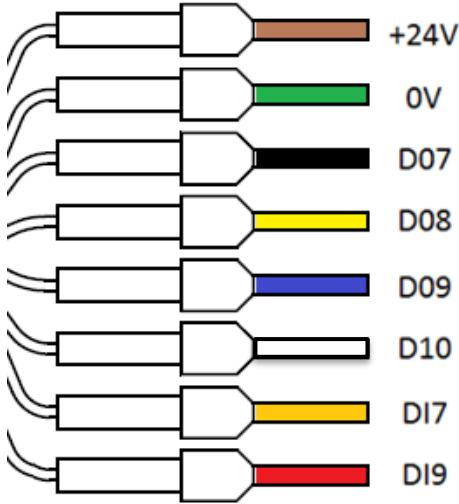

Brown	+24V
Green	0V
Black	DO.7
Yellow	DO.8
Blue	DO.9
White	DO.10
Orange	DI.7
Red	DI.9



DANGER:

The connector with 8 channels connected to Control box and the TM Robot, which connects the screw driver's controller with 6 channels, must not have contact with one another. This may in result to short circuit and occasionally damage the product.

Step 5 Assemble the Air Conditioning Valve and Air tube

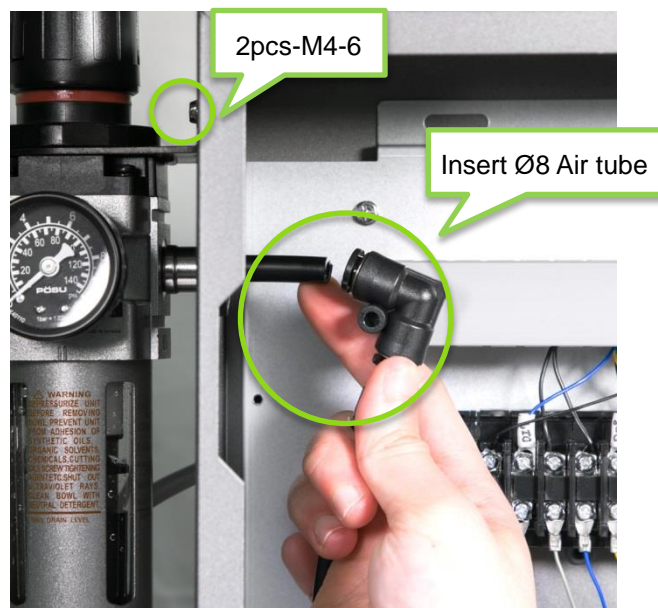

Step 6 Connect venting air tube and intake air tube of Air Conditioning Valve

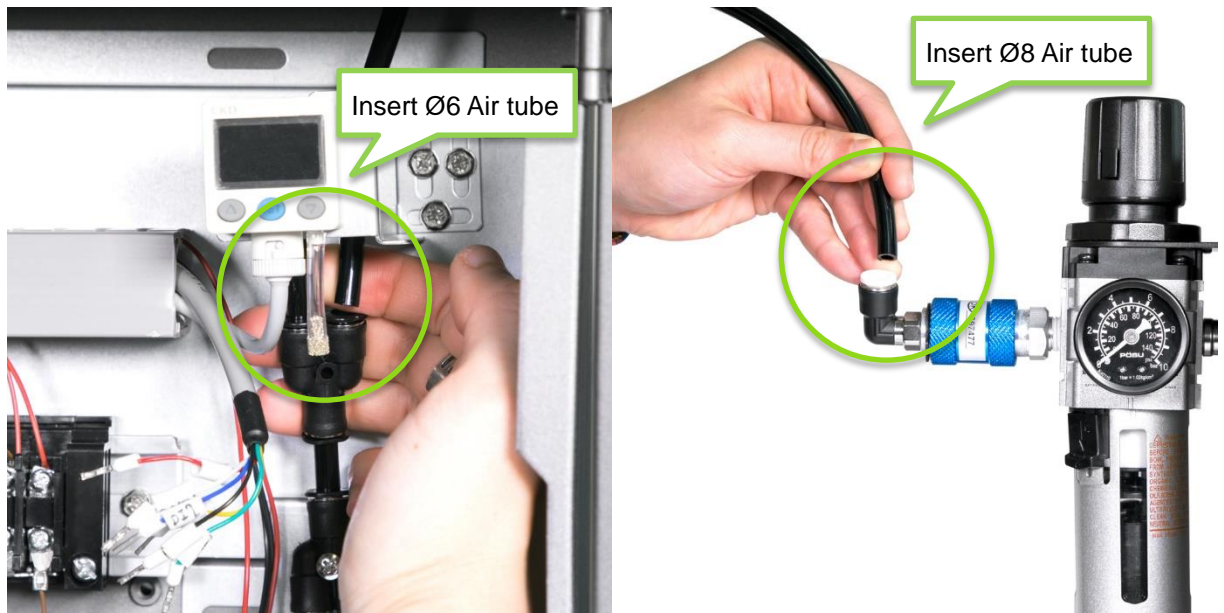

Step 7 Solenoid valve ON/OFF

Blue metal part left pulled as solenoid valve OFF; blue metal part right pushed as solenoid ON.



Step 8 Adjust suitable pressure

Lift up the cap to adjust the pressure. After adjustment, push it back and the pressure should stay at 3 bar.

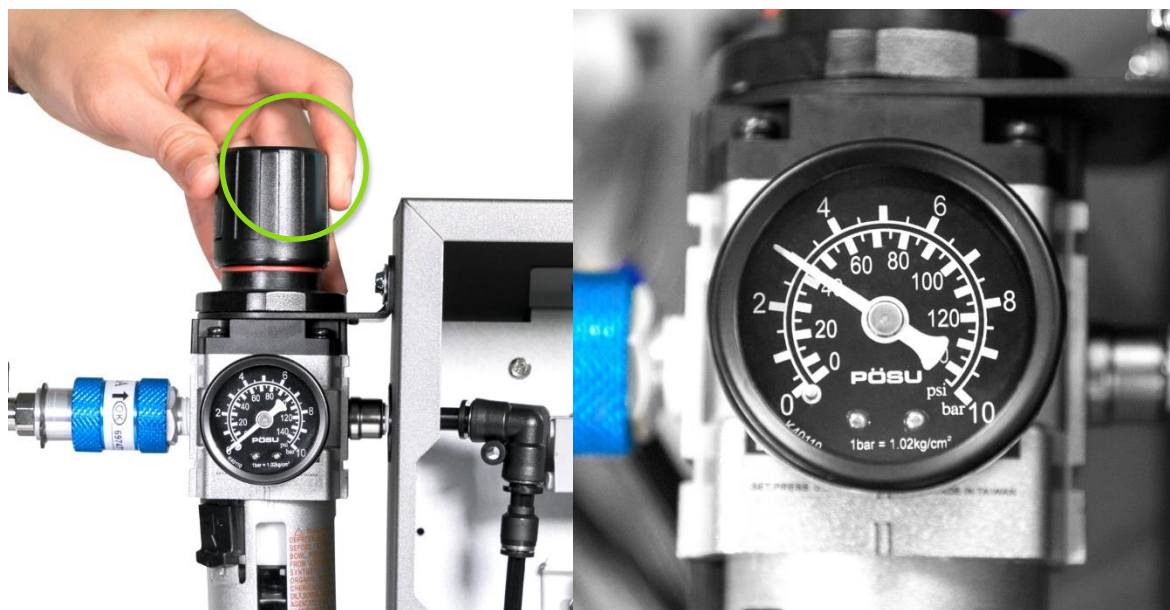

Step 9 Testing pressure

Give orders through IO command by using TM Robot HMI and examine whether or not it fulfils the below condition when vacuuming:

Suction-9 ~ -11kPa; blowing >80kPa

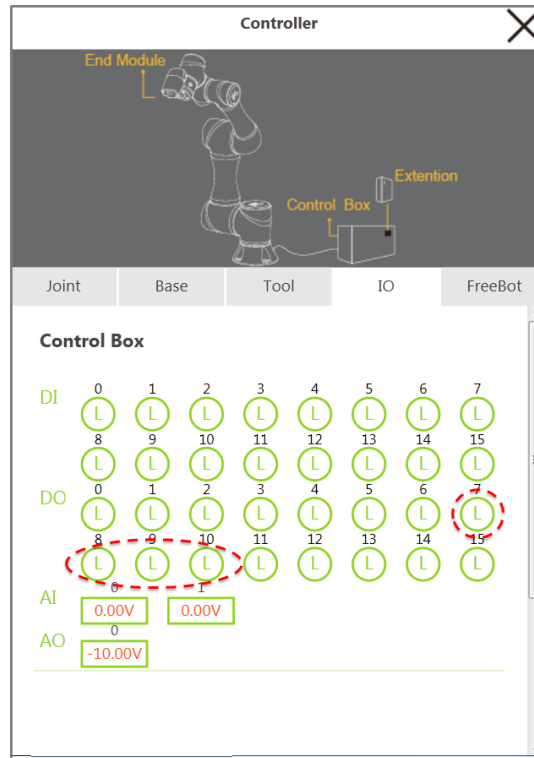

DO.7	Screw driver rotate
DO.8	Counter-rotate
DO.9	Suck
DO.10	Blow

If you cannot reach the above values, confirm whether or not there's leaking or regulating valve pressure is less than 3bar.

For detailed user manual of the sensor, download it from CKD's official website as below:

<http://www.ckdtaiwan.com.tw/catafile/pdf/CC-1345T.pdf>

Step 3 Set OUT1 function setting mode as comparator setting mode

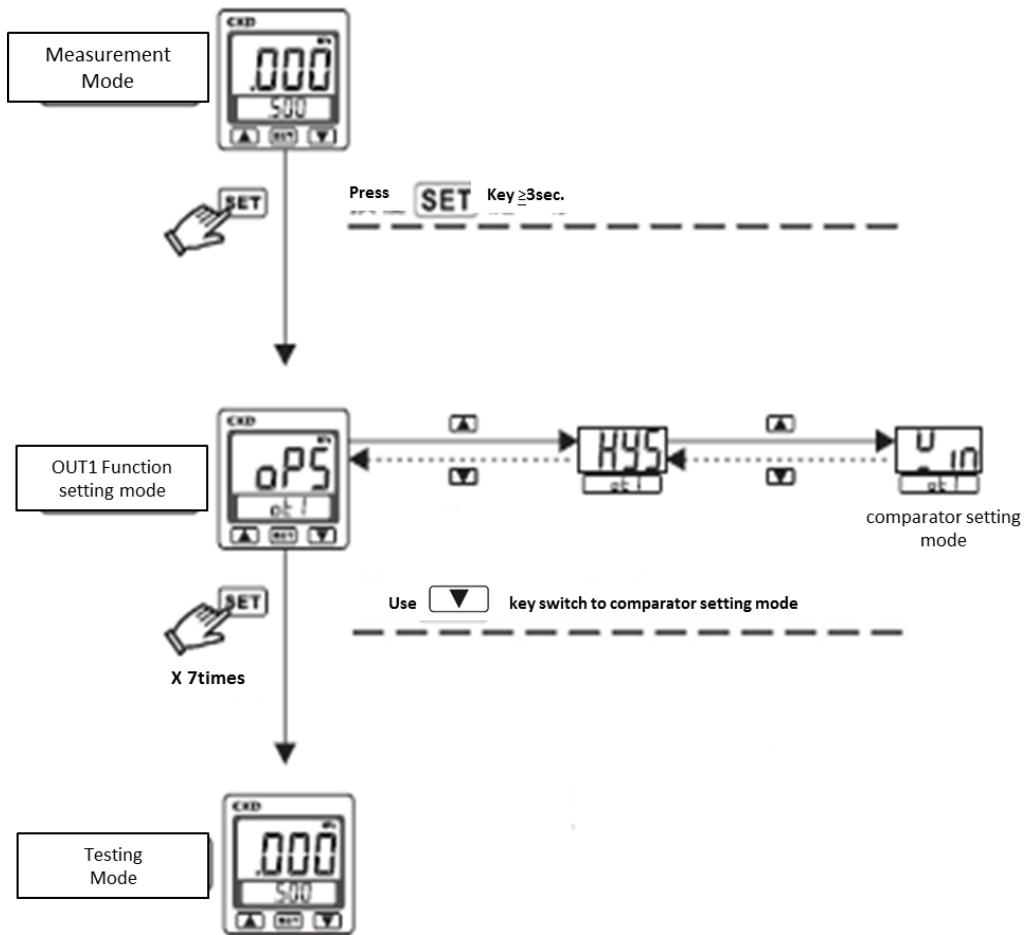

Step 4 Set the Max. / Min. value of pressure

Set H-1 as -11 Kpa · L-1 as -9Kpa · between the range of -9~-1, the pressure sensor will give output signal. Users can base on the signal and know whether or not the suction/blowing is successful.

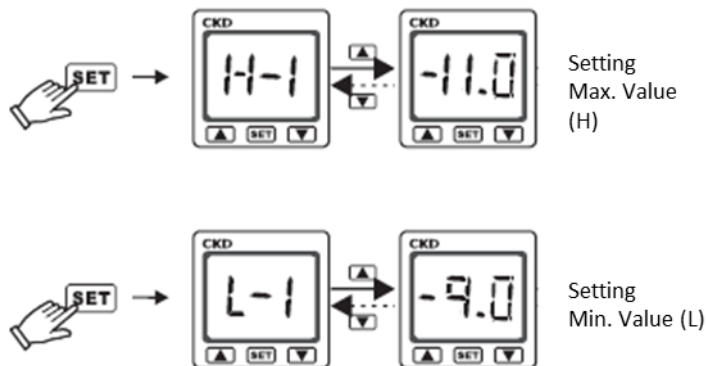

4. KILEWS Accessories

The accessories that TM pneumatic control box (TM Hardware Kit) provides, such as KILEWS stamping parts and KILEWS control box, are compatible with KILEWS Screw Driver Model BN512L. For detailed information refer to the manual TM Plug & Play KILEWS Screwing Installation.

Appendix A TM Robot Control Box HW 3.0 Wires Assignment

TM Control Box Digital IN wires assignment

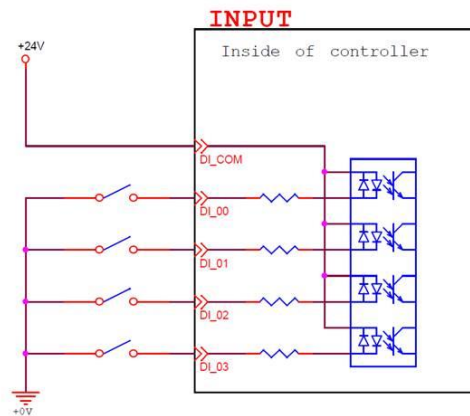
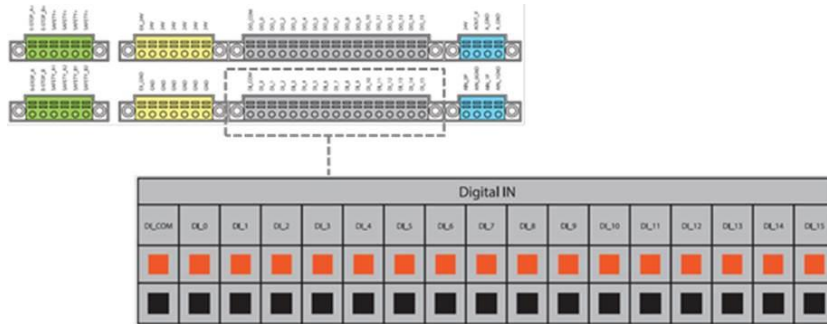

TM Control Box Digital OUT wires assignment

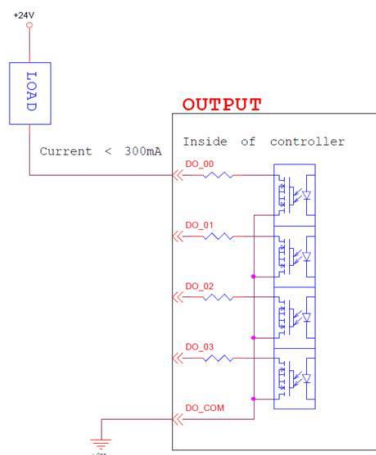
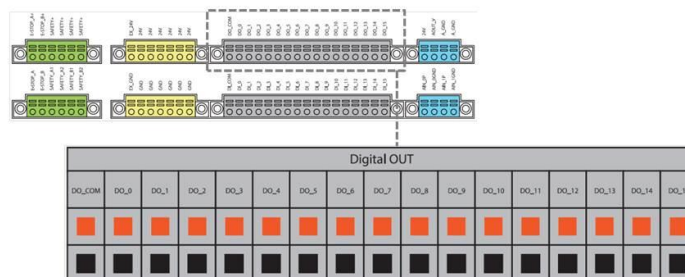

Appendix B Terminal Block Description



Upper Right to Left ①~⑩ · Bottom Right to Left ⑪~⑳ ◦

Terminal block	Device Equipment	Remarks
①	Solenoid valve A (Red)	+24V(with cooper pieces)
②	Solenoid Valve B(Red) Sensor (Brown)	
③	Sensor (Blue) Kilews IO BOX Pin5 (Red)	0V(with copper pieces)
④	Kilews IO BOX Pin2 Start IN GND (Yellow) Kilews IO BOX Pin4 Rev IN GND (Blue)	
⑤	Kilews IO BOX Pin1(White)	Screwdriver Turns
⑥	Kilews IO BOX Pin3(Green)	Reverse mode
⑦	Solenoid Valve B (Black)	Suction
⑧	Solenoid Valve A (Black)	Blow
⑨	Kilews IO BOX Pin7 (Black)	
⑩	Sensor (Black)	
⑪	Robot Control Box (Brown)	+24V
⑫		
⑬	Robot Control Box (Green)	0V
⑭		
⑮	Robot Control Box DO.7 (Black)	
⑯	Robot Control Box DO.8 (Yellow)	
⑰	Robot Control Box DO.9 (Blue)	
⑱	Robot Control Box DO.10 (White)	
⑲	Robot Control Box DI.7 (Orange)	
⑳	Robot Control Box DI.9 (Red)	



OMRON Corporation Industrial Automation Company

Kyoto, JAPAN

Contact: www.ia.omron.com

Regional Headquarters

OMRON EUROPE B.V.

Wegalaan 67-69, 2132 JD Hoofddorp

The Netherlands

Tel: (31)2356-81-300/Fax: (31)2356-81-388

OMRON ASIA PACIFIC PTE. LTD.

No. 438A Alexandra Road # 05-05/08 (Lobby 2),

Alexandra Technopark,

Singapore 119967

Tel: (65) 6835-3011/Fax: (65) 6835-2711

OMRON ELECTRONICS LLC

2895 Greenspoint Parkway, Suite 200 Hoffman Estates,

IL 60169 U.S.A.

Tel: (1) 847-843-7900/Fax: (1) 847-843-7787

OMRON ADEPT TECHNOLOGIES, INC.

4550 Norris Canyon Road, Suite 150, San Ramon, CA 94583 U.S.A.

Tel: (1) 925-245-3400/Fax: (1) 925-960-0590

OMRON (CHINA) CO., LTD.

Room 2211, Bank of China Tower, 200 Yin Cheng Zhong Road,

PuDong New Area, Shanghai, 200120, China

Tel: (86) 21-5037-2222/Fax: (86) 21-5037-2200

Authorized Distributor:

© OMRON Corporation 2018 All Rights Reserved.
In the interest of product improvement,
specifications are subject to change without notice.

Cat. No I630-E-01

1018 (1018)

19888-930 A