



San Joaquin

Joint Powers Authority

May 31, 2019 Board Meeting



San Joaquin Joint Powers Authority

Item 1

Call to Order

Pledge of Allegiance

Roll Call



Item 2

Consent Calendar

- 2.1 Approve Minutes from March 22, 2019 Board Meeting
- 2.2 Next Board Meeting Location (July 26, 2019) – Modesto, CA
- 2.3 SJJPA Operating Expense Report
- 2.4 San Joaquins Operations Update
- 2.5 Update on Valley Rail Program



San Joaquin Joint Powers Authority

Item 2

Consent Calendar

- 2.6 Wi-Fi Update
- 2.7 Administrative Items
- 2.8 Approve a Resolution of the Governing Board of the San Joaquin Joint Powers Authority Ratifying All Actions Taken by the SJJPA Board at its March 22, 2019, Meeting as Reflected in the Meeting Minutes



San Joaquin Joint Powers Authority

Item 2

Consent Calendar

- 2.9 Approve a Resolution of the Governing Board of the San Joaquin Joint Powers Authority Authorizing the Executive Director to Submit and Execute Any and All Grant Applications, Agreements, Certifications and Assurances and Any Other Documents Necessary to Obtain FY 17/18 and FY 18/19 State Rail Assistance (SRA) Funding in the Amount of \$7,100,000 for the Stockton Diamond Grade Separation Project



San Joaquin Joint Powers Authority

Item 3

Public Comments



San Joaquin Joint Powers Authority

Item 4

**Presentation by Caltrans on
Siemens Equipment and Platforms
Update**

Momoko Tamaoki

Caltrans and San Joaquin JPA New Single Level Coaches

Momoko Tamaoki

May 31, 2019



Single-Level Coach Configuration

Coach Types

Five Types in a Seven-Car Consist

Total Quantities:

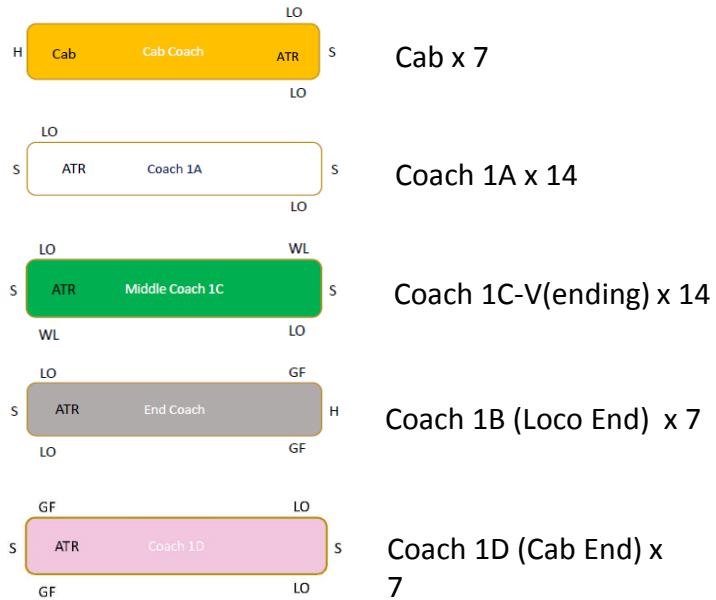

Legend:

- H = H-Type Coupler (Consist Ends)
- S = Semi-Permanent Coupler (Wide Gangway)
- WL = Wheelchair Lift (Hi-Floor entry)
- LO = Low Floor Entry (2 sliding steps and then 3 steps to the car level)
- GF = Gap Filler/Bridge Plate (Level Boarding)
- ATR = Accessible Toilet Room

Café - Vending Concept

Provisions Included on 1C-V (Two Per Consist)

- Space for 3x Vending Machines & Condiment Area
- Flexible Electrical Provisions
- Passenger Self-Service Water Dispenser at Opposite End
- Specs for Mounting, Weight, Space Requirements Provided

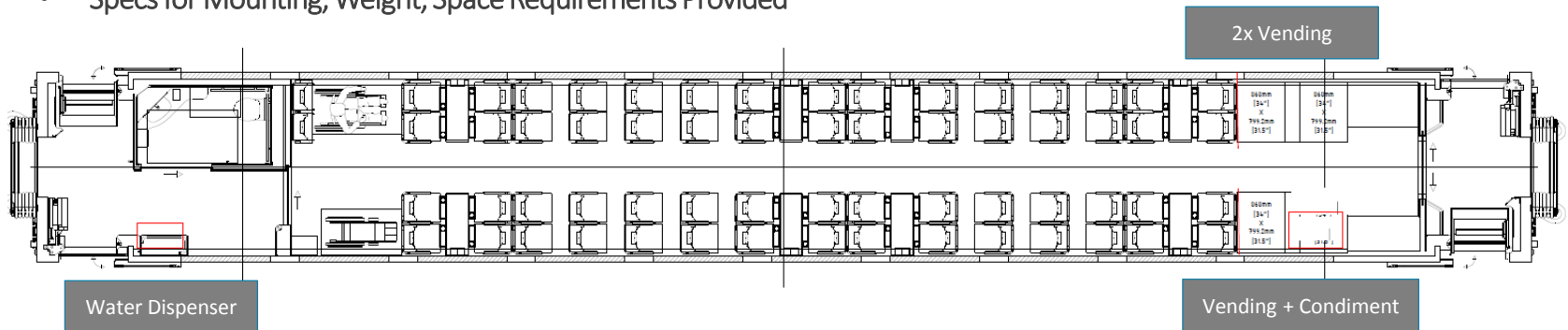

Deployment Schedule

New Single Level Railcar Deployment Plan - 1

Date	Description	Railcars Delivered	Railcars in Revenue Service	Consists Deployed
Sep 2020	First consist deployed (Coach 1A and 1B)	8	6	1
Mar 2021	Second consist deployed (Coach 1A and 1B)	16	11	2
May 2021	Third consist deployed (Coach 1A, 1B, and 1D)	20	16	3
July 2021	Fourth consist deployed (Coach 1A, 1B, and 1D)	25	21	4
Aug 2022	First Vending Car delivered and deployed	26	21	4
Jan 2023	Fifth consist deployed (Convert 1A's to End Cars)	29	26	5

1A – Standard Coach; 1B – Loco End Coach; 1C – Vending Coach; 1D – Cab End Coach

New Single Level Railcar Deployment Plan - 2

Date	Description	Railcars Delivered	Railcars in Revenue Service	Consists Deployed
Apr 2023	Two Vending Cars delivered and deployed	31	26	5
July 2023	Four Vending Cars, 3 Cab Cars delivered; Sixth Consist deployed	38	36	6
Aug 2023	Four Cab Cars delivered; Seventh Consist deployed; Reconvert 1A End Cars to 1A Coaches	42	42	7
Jan 2024	Four Vending Cars delivered	46	46	7
Mar 2024	Three Vending Cars delivered	49	49	7

1A – Standard Coach; 1B – Loco End Coach; 1C – Vending Coach; 1D – Cab End Coach

Single-Level Coach Features

Open Gangways with Automatic Doors

Car-to-Car ADA Access Through Aisleways and Vestibules

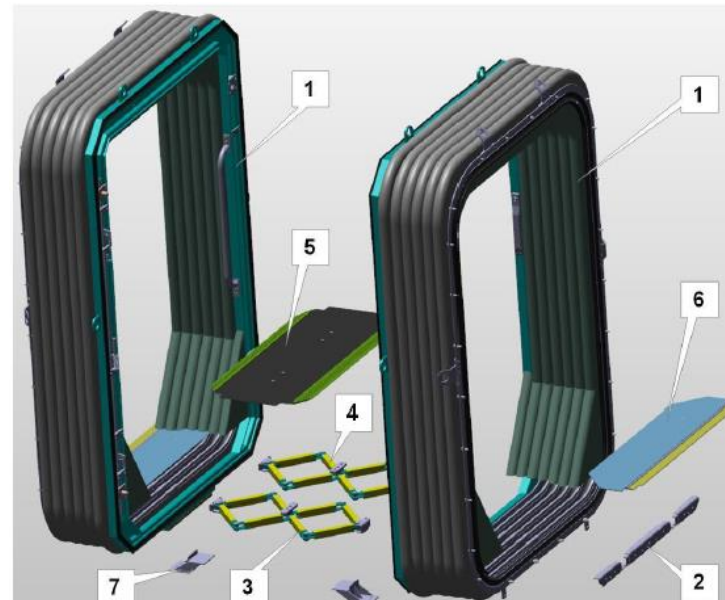

Item	Description
1	Double corrugated bellow half
2	Mounting bracket
3	Scissor assembly
4	Sliding scissor assembly
5	Tread plate assembly
6	Bridge plate assembly
7	Gangway support bracket

Semi-Permanent Couplers

Improved Ride Quality & Built-In CEM Features

Approximately 35 Minutes to Couple/Uncouple (2x Crew)

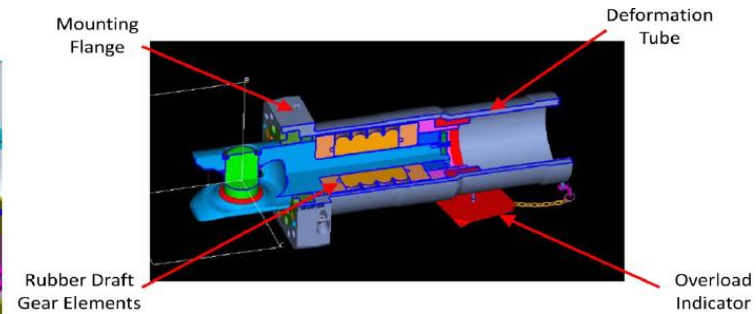
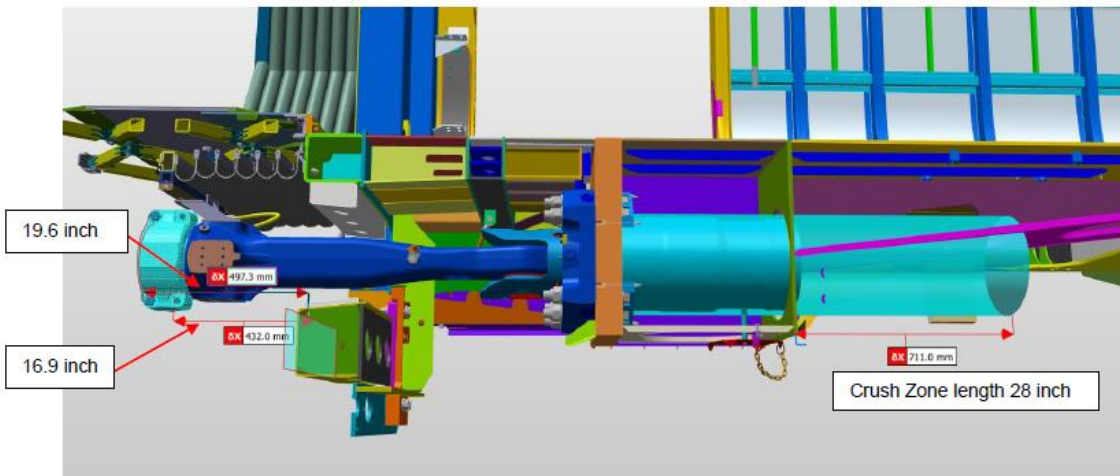

Trainlined Door Control

Long and Short Door Leaf Plug Doors



Example Sliding Plug Door

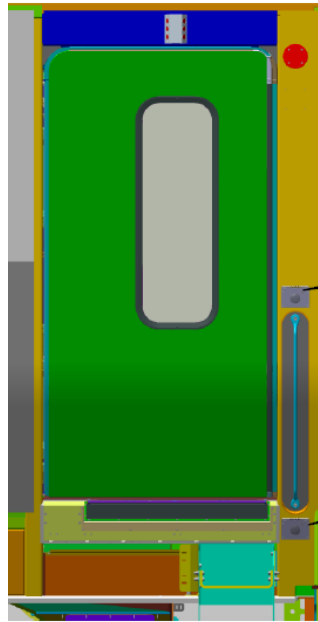

Short Door Leaf – High Boarding

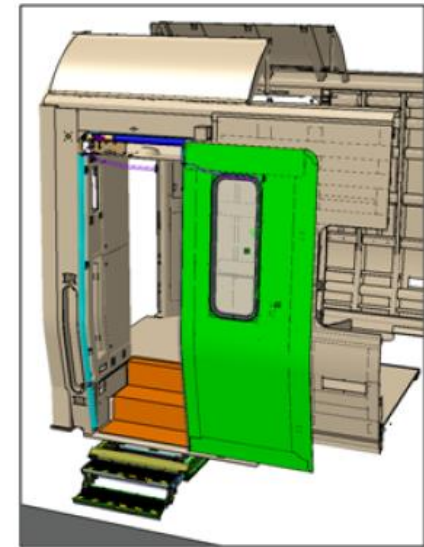

Long Door Leaf – Low Boarding

Advanced Communication & Diagnostics

Passenger Information Systems and Fault Detection

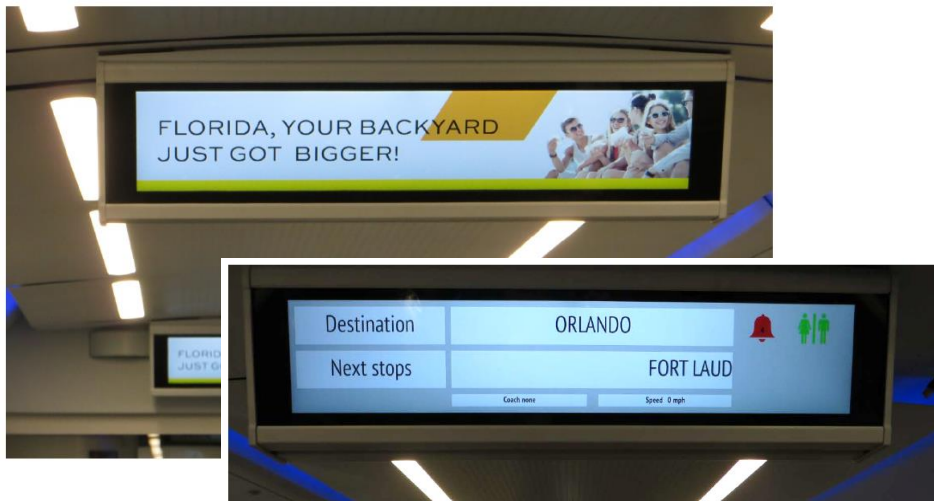

- Programmable Destination & Information Signs
- Diagnostic Terminal in Each Car
- Automated Announcements
- Passenger Emergency Intercom

ALL Cars [7] Mon 02-26-2018 11:09:35

A1 B1 C4 MCB doors entrance left tripped

9022	4002	MCB doors entrance left tripped	1	02-26-2018	08:13:52
9022	2022	Transformer secondary contactor OFF faulty	2	02-26-2018	08:13:52
9022	5065	Axle bearing controller HJD endA internal error	2	02-26-2018	03:43:15
9022	5066	Axle bearing controller HJD endB internal error	2	02-26-2018	03:43:15
9022	1029	Freeze protection heat tapes switch on faulty	1	02-26-2018	03:34:21
9022	2043	Manual activation of HEP does not work	1	02-22-2018	09:43:20

9022 1B | 9001 1A | 9002 1A | 9801 5A | 9003 1A | 9029 1C | 9301 4A | ALL Cars

A B C | [Train Icon] | [Wrench Icon] | Filter | X

- Passenger Wi-Fi Configuration In-Work
- Digital Trainline Throughout Consist
- Options for Remote Reporting & Notification
- Options for Wireless Destination & Info Updates

Modern Layouts, Lighting & Seating

Clean, Open Interiors and Custom Lighting



- **Clean Interior with Low-Maintenance Seating**
- **Workstation Tables, Folding Trays**
- **Accessible Restrooms with Touch-Free Controls**
- **Redundant Passenger and Emergency Lighting**

Flexible Boarding Options

High and Low-Level Boarding and Wheelchair Lifts

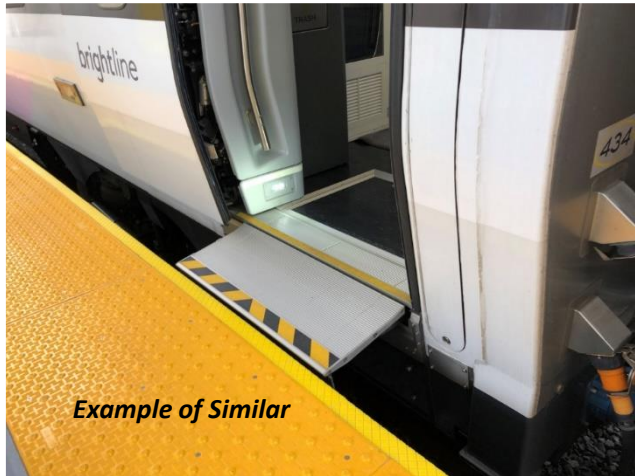

Example of Similar

*High Level Boarding Example
(Extended Bridge Plate Will be Required)*

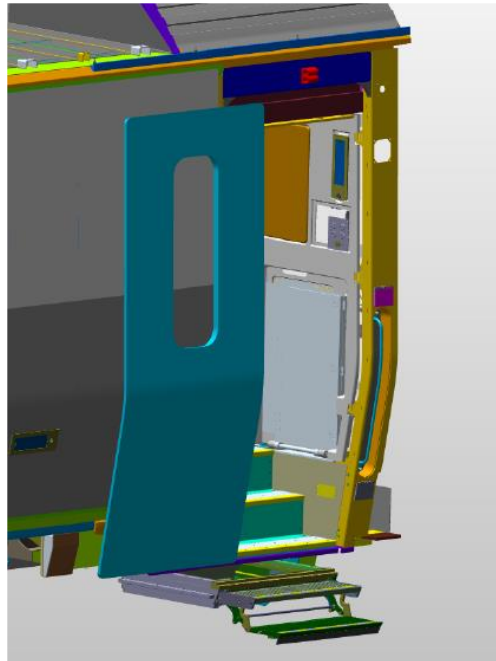

Low-Level Boarding with Automatic Steps

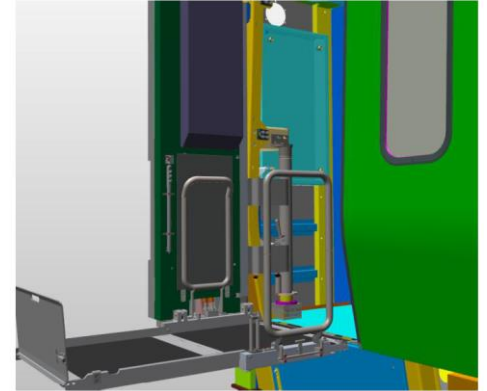

Wheelchair Lifts on 1C Cars – 2 per Consist Side



Example of Similar

Platform Study and Mini-High Design

Platform Constraints

Clearances

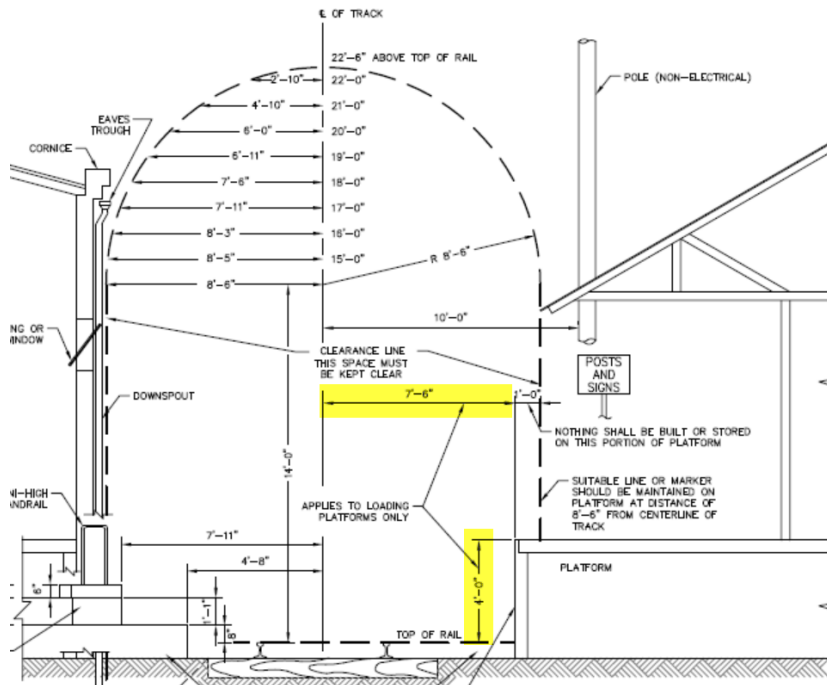

- Siemens Coach design provides level boarding for platforms at **48"** Above Top of Rail, meeting the STRACNET clearance of 75" from track centerline.
- Current San Joaquin Corridor station platforms are at **8"** Above Top of Rail
- California Public Utilities Commission (CPUC) General Order 26D requires platform clearance of **90"** from track centerline.

Mini-High Platforms

Current design(s):

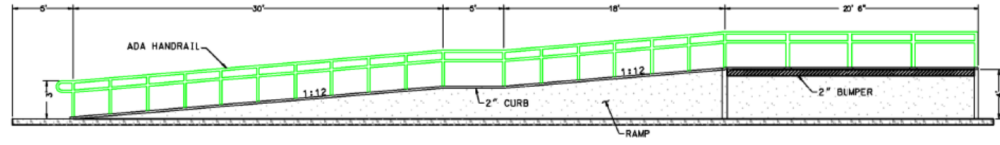
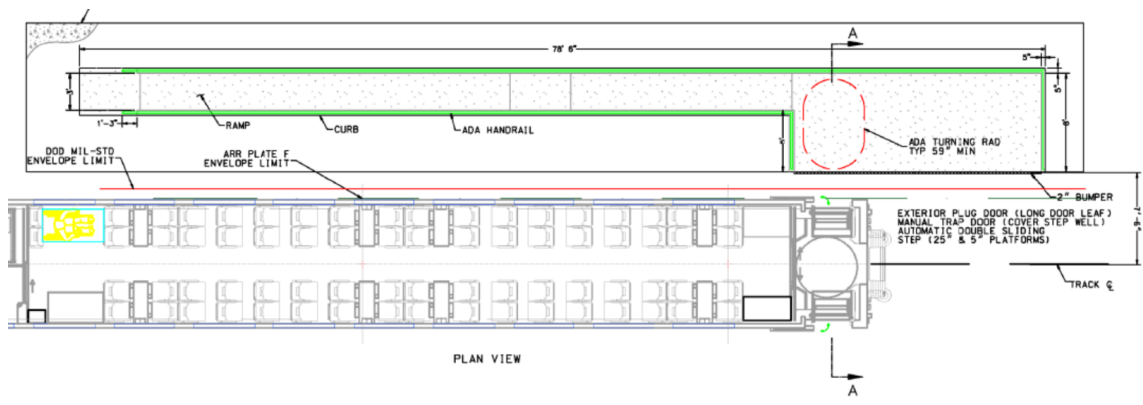

Straight ramp

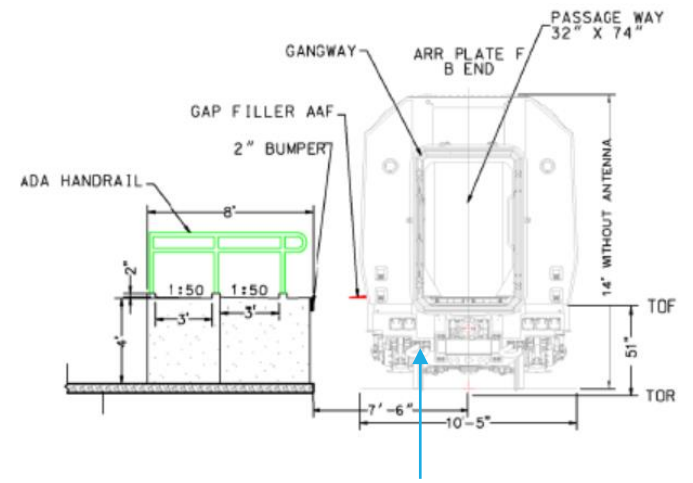

Potential gap from CPUC clearance

Mini-High Platforms

Current design(s):

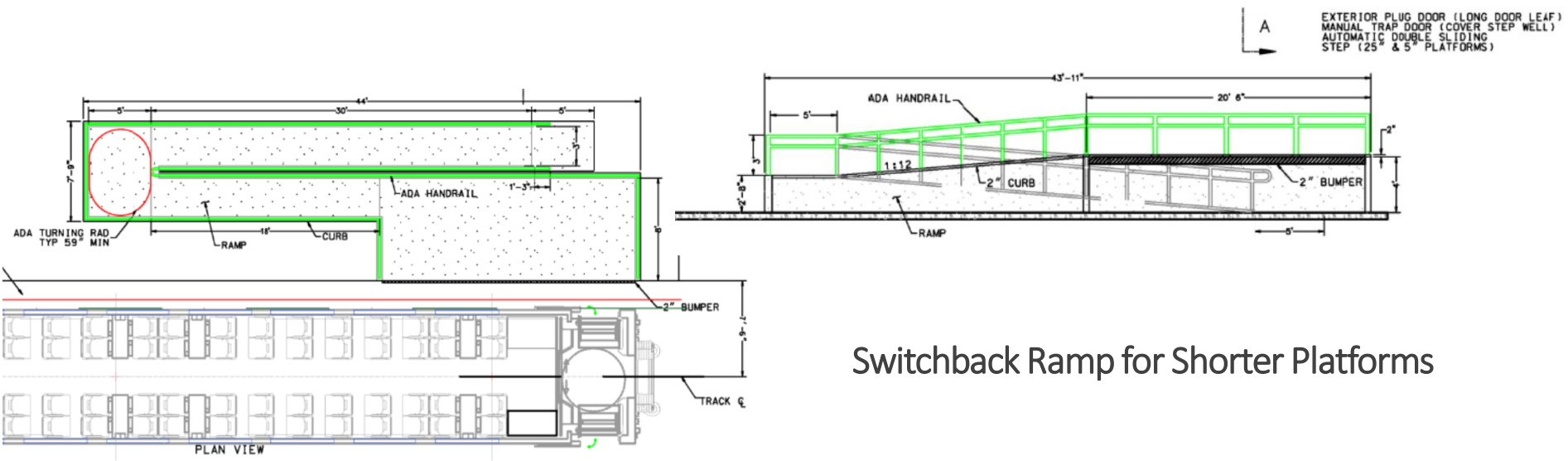

Switchback Ramp for Shorter Platforms

Mini-High Platforms

Implementation:



Modesto Station example (CPUC clearance included)

Car-borne Bridge Plates

Current status:

- Original proposal was to have a moving edge on mini-high platforms that would deploy when boarding, and retract after trainset departure (see photo below)
 - Host railroads insisted that this would **not** be allowed under any circumstance and CPUC GO 26D needed to be maintained at all times.



Movable edge of platform
(**not** allowed by host railroads for this project)

Car-borne Bridge Plates

Current status:

- Car-borne bridge plate is being evaluated:
 - Due to required length, hand rails will likely be required.
- Working with Siemens on flip down bridge plate concept:
 - Bridge plate would be permanently attached to vehicle and capable of flipping down at stations.

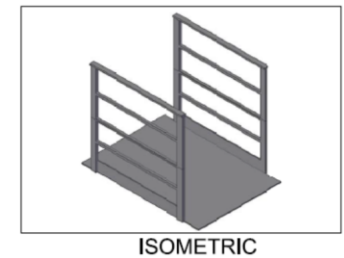
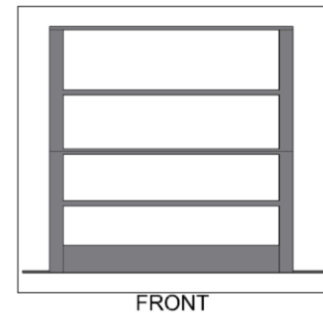
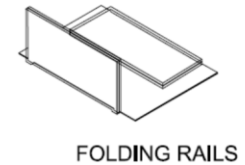
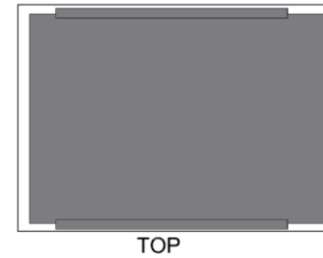
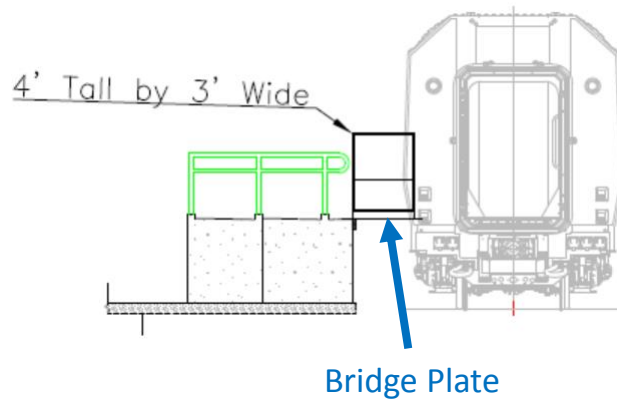



Brightline Florida Photos



Trainset and Platform



Shop and Vestibule



Seats and Luggage Rack

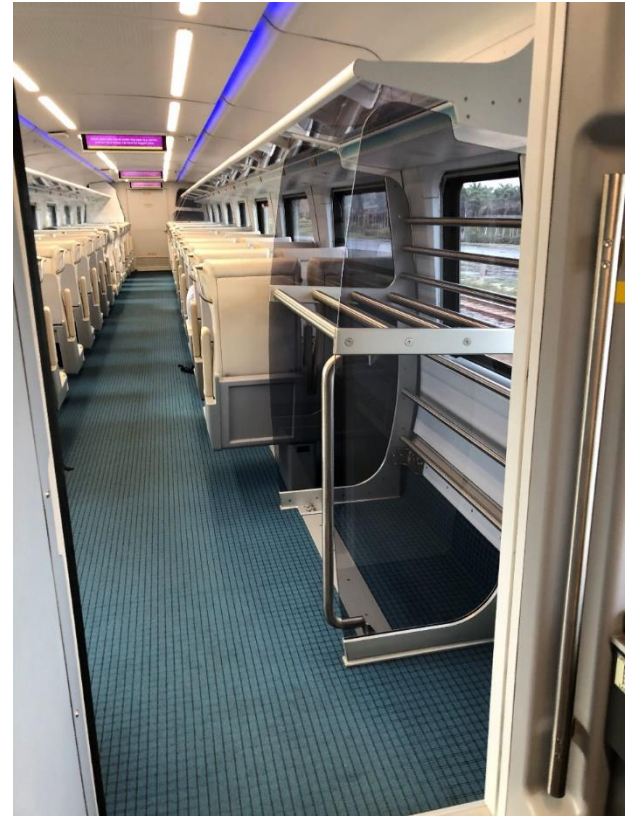

Thank you – Q&A





San Joaquin Joint Powers Authority

Item 5

Approve a Resolution of the Governing Board of the San Joaquin Joint Powers Authority Approving the Final 2019 San Joaquin Joint Powers Authority Business Plan Update and Authorizing and Directing the Executive Director to Execute Any and All Documents Associated with the Master Fund Transfer Agreement Supplements for Operations, Administration, and Marketing Budgets for Fiscal Year 2019/2020

Stacey Mortensen

Adopt 2019 SJJPA Final Business Plan

- ❑ The Annual Business Plan must be submitted to the Secretary of CalSTA in draft form by April 1 of each year, and final form by June 15 of each year.
- ❑ The purpose of establishing the later date for the final version is to allow Amtrak time to finalize operating cost estimates.
- ❑ The final version of the Annual Business Plan is used to develop an annual appropriation request to the State Legislature.



SAN JOAQUIN JOINT POWERS AUTHORITY 2019 BUSINESS PLAN UPDATE

PREPARED FOR CALIFORNIA STATE TRANSPORTATION AGENCY
UPDATED FOR FY 2019/2020 & FY 2020/2021

Adopt 2019 SJJPA Final Business Plan

- The Draft 2019 SJJPA Business Plan was unanimously approved at the March 22, 2019 SJJPA Board Meeting and submitted to CalSTA on April 1, 2019.
- Final 2019 SJJPA Business Plan includes revised Amtrak contact amount for FY 2019/20 from \$53,002,184 to 56,676,590 and for FY 2020/21 from \$54,592,250 to \$58,805,207
- A Final 2019 SJJPA Business Plan clean version were included in briefing materials. These are available on the SJJPA website: www.sjjpa.com

Adopt 2019 SJJPA Final Business Plan

Key Changes from the Draft 2019 SJJPA Business Plan:

- Updated State Funding Request table in the Executive Summary and Chapter 10.
 - The changes from Draft to Final in this table are in the Other Operations line item which was revised from \$2,156,000 to \$3,616,000 to include \$1,000,000 in Host Railroad Incentive Payments, an increase of the Madera-San Jose Thruway Bus from \$800,000 to \$1,000,000 and an increase of CalPIDS from \$240,000 to \$500,000.

- An additional FY2019/2020 Other Operations funding table is included in Chapter 10 which shows each project within the Other Operations line item.

Adopt 2019 SJJPA Final Business Plan

Key Changes from the Draft 2019 SJJPA Business Plan:

- Updated Chapter 13 language under the Bakersfield TOD subsection that removed text “... and in the city’s High-Speed Rail Station Area Plan.”
- Updated FY 2018/19 Forecast of the Amtrak Contract from \$47,804,768 to \$50,038,821 which includes updated FY 18/19 actual expenses, which was then forecasted to the end of the FY 18/19 Amtrak Contract.
- Updated Chapter 10 language to include FY 2017/18 Administrative Fiscal Report (Actuals).

Adopt 2019 SJJPA Final Business Plan

Fiscal Impact:

- Adoption of the Final 2019 SJJPA Business Plan is required for the SJJPA to continue managing the San Joaquins and receive funding from the State for the administration, marketing, and operations for the San Joaquins.

Recommendation:

- Approve a Resolution of the Governing Board of the SJJPA Adopting the Final 2019 SJJPA Business Plan Update and Authorizing and Directing the Executive Director to Execute Any and All Documents Associated with the Master Fund Transfer Agreement Supplements for Operations, Administration, and Marketing Budgets for Fiscal Year 2019/2020



San Joaquin Joint Powers Authority

Item 6

Approve Two Resolutions of the Governing Board of the San Joaquin Joint Powers Authority Authorizing the Executive Director to Negotiate and Enter into an Agreement for Project Development Services to AECOM for an Amount Not-To-Exceed \$366,000 for the Madera Station Relocation Project and Establish a Pre-Qualified On-Call Consultant List for a Period of Five (5) Years for the Capital Projects Program

Action 1. Approve an Agreement for Project Development Services to AECOM for an Amount Not-To-Exceed \$366,000 for the Madera Station Relocation Project

Action 2. Adopt and Establish a Pre-Qualified On-Call Consultant List for a Period of Five (5) Years, May 31, 2019 Through May 31, 2024 provided in Table 3 in the Staff Report

Kevin Sheridan

BACKGROUND

- The Valley Rail Project is identified within the Capital Projects Program and includes many separate projects that will expand the ACE and San Joaquin Services.
- Twenty-nine (29) projects were identified as needing Professional Consulting Services in the following categories: Project Development, Right of Way, Construction Management and Rail Engineering Services.
- Of the twenty-nine (29) projects, thirteen (13) were identified as needing immediate contracts for services as part of the first phase of the Program.

CONSULTANT SELECTIONS

- ❑ On January 15, 2019 SJRRC released a Request for Qualifications for the needed Professional Consultant Services on an On-Call basis.
- ❑ Thirty-three (33) Statements of Qualifications (SOQs) were received by the RFQ deadline of February 22, 2019. Of the received SOQs, thirty (30) were deemed responsive.
- ❑ The proposals were evaluated by a panel consisting of representatives from SJRRC, SJCOG, Caltrans, and the Cities of Modesto, Manteca and Lathrop.

TABLE 1. IMMEDIATE CONTRACT SERVICES

Category A. Project Development Services		
Project	Consultant	Not-To-Exceed Amount
Madera Station Relocation	AECOM Technical Services, Inc.	\$366,000
Natomas/Sacramento Airport Station & Layover Facility (Shared)	AECOM Technical Services, Inc.	\$500,000*
North Elk Grove Station (Shared)	Mark Thomas & Company, Inc.	\$401,600*
Total Not-To-Exceed Amount for Project Development Services:		\$366,000

*SJJPA delegated authority to SJRRC for shared ACE/SJJPA stations.

TABLE 2. ESTABLISHED A PRE-QUALIFIED ON-CALL CONSULTANT LIST

Rankings	A. Project Development	B. Right of Way	C. Construction Management	D. Rail Engineering Services
1.	AECOM Technical Services, Inc.	Paragon Partners Ltd.	PGH Wong Engineering, Inc.	Pennino Management Group
2.	HDR Engineering, Inc.	Property Specialists, Inc. (dba CPSI)	NV5, Inc.	Rail Surveyors and Engineers, Inc.
3.	T.Y. Lin International	Overland, Pacific & Cutler, LLC	Pennino Management Group	Lockwood, Andrews & Newnam, Inc.
4.	EXP		Kleinfleder Construction Services, Inc.	
5.	Rail Surveyors and Engineers, Inc.		MNS Engineers, Inc.	
6.	Sener Engineering and Systems, Inc.		WSP, USA, Inc.	
7.	TranSystems		Mott Macdonald, LLC	
8.	Anil Verma Associates, Inc.			
9.	Biggs Cardosa Associates, Inc.			

The pre-qualified consultants are listed in order of rank and by service they will be providing.

RECOMMENDATION

Fiscal Impact

- Funding has been secured for the projects being awarded for immediate contracting services.
- Funding sources utilized include State funding from the \$500M TIRCP award for the Valley Rail Project, the \$400M allocation from SB 132, and the State Rail Assistance (SRA) Program created by SB 1; Federal funding from the Congestion Mitigation and Air Quality (CMAQ) Improvement Program and the Urbanized Area Formula Funding Program; and Local funding through Measure K in San Joaquin County and Measure B in Alameda County.
- Expenditures occurring in FY 2018-19 are identified in the San Joaquin Regional Rail Commission/ACE/SJJPA Fiscal Year 2018/2019 Capital Budget. The Fiscal Year 2019/2020 Capital Budget will identify all costs occurring in the upcoming fiscal year.

RECOMMENDATION (CONT.)

- Amendments to the awarded contracts will be brought before the Board for approval.
- Contracts awarded from the established shortlist will be reviewed and approved by the Board.

RECOMMENDATION

- Approve Two Resolutions of the Governing Board of the San Joaquin Joint Powers Authority Authorizing the Executive Director to Negotiate and Enter into an Agreement for Project Development Services to AECOM for an Amount Not-To-Exceed \$366,000 for the Madera Station Relocation Project and Establish a Pre-Qualified On-Call Consultant List for a Period of Five (5) Years for the Capital Projects Program
- Action 1. Approve an Agreement for Project Development Services to AECOM for an Amount Not-To-Exceed \$366,000 for the Madera Station Relocation Project
- Action 2. Adopt and Establish a Pre-Qualified On-Call Consultant List for a Period of Five (5) Years, May 31, 2019 Through May 31, 2024 provided in Table 3 in the Staff Report



San Joaquin Joint Powers Authority

Item 7

Approve a Resolution of the Governing Board of the San Joaquin Joint Powers Authority Authorizing an Agreement for the Advertising and Marketing Campaign for the Slotted Schedule to Jeffery Scott Agency for an Amount Not-To-Exceed \$500,000 from June 1, 2019- through the Projects Completion, and Authorizing and Directing the Executive Director to Execute the Agreement

David Lipari/ Kevin Sheridan

Request for Advertising and Marketing Contract

- In the 2018 SJJPA Business Plan, \$500,000 was requested for Marketing and Advertising a “Bay Area Morning Express Train”.
 - This funding request was approved in the “Business Plan Approval Letter” received on September 17, 2018 in Section 1.d.i. Typically, SJJPA has requested these additional funds to supplement the standard marketing allocation to focus on a new service/project without interrupting the overall marketing plan.
- Due to SJJPA in partnership with the State restructuring the San Joaquins schedule away from Morning Express to full-corridor service, the “Bay Area Morning Express Train” is not planned to operate in FY18/19 or FY19/20.

Request for Advertising and Marketing Contract

- The recent May 7, 2018 San Joaquins schedule change negatively impacted ridership to/from Los Angeles and a portion of the core leisure travel market in the San Joaquin Valley.
- Concerted effort of SJJPA and the State to restructure the San Joaquins schedule with the intent to:
 - ▣ Improve On-time Performance
 - ▣ Re-establish lost connections
 - ▣ Improve mobility to/from Los Angeles, and return the San Joaquins to a model for ridership and revenue growth

Request for Advertising and Marketing Contract

- SJJPA requested the use of the funds identified in Section 1.d.i. to be utilized to market and advertise the service under its new schedule with a primary focus on connections to/from Los Angeles.
- This change of scope request from the State was approved on February 20, 2019.
- The campaign would promote the new “Slotted Schedule” and its three primary objectives stated previously.

Request for Proposal (RFP) and Selection Process:

- On March 18, 2019, San Joaquin Joint Powers Authority (SJPPA) released a Request for Proposals (RFP) via vendor portal Planet Bids for the solicitation of Advertising Services for the New Slotted Schedule.
- By utilizing Planet Bids, twenty-eight (28) firms were notified of the opportunity. Twenty-five (25) firms showed interest, twenty (20) firms downloaded the solicitation documents and three (3) firms submitted proposals by the due date of April 22, 2019.
- SJPPA received proposals from the following firms:
 - DB&M Media, Inc.
 - Jeffrey Scott Agency
 - Pastilla

Request for Proposal (RFP) and Selection Process:

- The proposals were evaluated by a panel consisting of SJJPA's Marketing Manager, Executive & Legislative Coordinator, and Marketing Coordinator.
- All firms were invited for interviews to allow the selection panel to evaluate the team in person. Firms were evaluated on presentation, and responses to the selection panel's questions. Scores from the interviews were combined with scores from the written proposals.
 - Based on the ranking, staff deems Jeffrey Scott Agency the most responsive and responsible proposer.
- The contract to be awarded is for an amount not-to-exceed \$500,000 total through the projects completion. Any additional funding for this project will be brought before the Board for approval and amended into the contract as needed.

Approve Advertising and Marketing Contract

Fiscal Impact:

- Cost associated with this Agreement are identified in the approved 2018 SJJPA Business Plan Update and approved by the State for this use.

Recommendation:

- Approve a Resolution of the Governing Board of the San Joaquin Joint Powers Authority Authorizing an Agreement for the Advertising and Marketing Campaign for the Slotted Schedule to Jeffrey Scott Agency for an Amount Not-To-Exceed \$500,000 from June 1, 2019 Through the Projects Completion, and Authorizing and Directing the Executive Director to Execute the Agreement



San Joaquin Joint Powers Authority

Item 8

Approve a Resolution of the Governing Board of the San Joaquin Joint Powers Authority Authorizing an Amendment to the On-Call Planning Consulting Services Agreement with DB Engineering & Consulting USA, Inc. for an Amount Not-to-Exceed \$200,000 from June 1, 2019 through the Projects Completion, and Authorizing and Directing the Executive Director to Execute the Agreement

Paul Herman/ Dan Leavitt

On-Call Planning Consultants Services Agreement

- With the recent approval and implementation of the May 20, 2019 San Joaquins schedule change, an on-going, bi-weekly meeting has been agreed upon by SJJPA staff, Amtrak, and BNSF Railways to monitor and analyze the performance of the new schedule and to create and maintain an action item list to address concerns and issues that arise from the performance of service.
- The goal of these meetings and the associated analysis is to improve the performance of the service and the railroad. From these meetings, operational analysis and on-time performance monitoring work will be necessary to address the concerns and issues of all parties.

On-Call Planning Consultants Services Agreement

- SJJPA staff is recommending that the On-Call Planning Consultant, DB Engineering & Consulting USA, Inc. be given additional funds to support these meetings and to perform the operational analysis and monitoring necessary to resolve issues and to develop recommendations based on the analysis performed.

- It is recommend that the consultant perform this work over the next two years after the implementation of the Spring 2019 schedule change, and the anticipated Spring 2020 schedule change.

- The contract total not-to-exceed amount of \$450,000 was approved on May 25, 2018 and is for services through FY 20/21. The additional services related to the new schedule work requires an increase to the contract amount of \$200,000.

Approve Amendment 03 to On-Call Planning Consulting Services Agreement

Fiscal Impact:

- On May 23, 2019 SJJPA received a letter from Caltrans authorizing \$200,000 from a one-time available fiscal year 18/19 operations augmentation funding. This funding does not require any updates to 2019 Business Plan.

Recommendation:

- Approve a Resolution of the Governing Board of the San Joaquin Joint Powers Authority Authorizing an Amendment 03 to On-Call Planning Consulting Services Agreement with DB Engineering & Consulting USA, Inc. for an Amount Not-to-Exceed \$200,000 from June 1, 2019 through the Projects Completion, and Authorizing and Directing the Executive Director to Execute the Amendment



San Joaquin Joint Powers Authority

Item 9

Altamont Corridor Vision Update

Dan Leavitt

Altamont Corridor Vision



SAN JOAQUIN
REGIONAL
RAIL COMMISSION

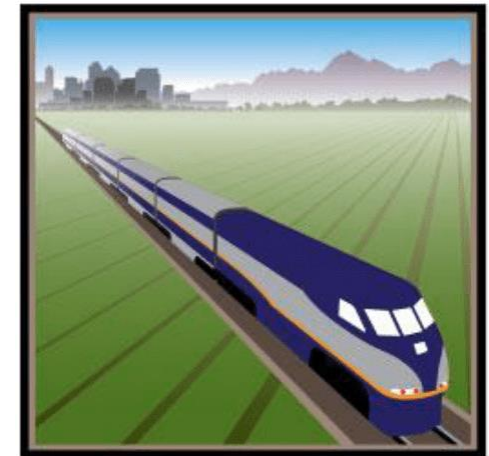

Connecting People, Housing, and Jobs



Tri-Valley & San Joaquin Valley
REGIONAL RAIL AUTHORITY

San Joaquin
Joint Powers Authority

Planning Update: April, 2019





Current ACE Connectivity Map

ACE
Route and Stations

- Light Rail
- BART
- Caltrain
- Capitol Corridor
- San Joaquin Corridor



WESTBOUND TRAINS

	ACE 1	ACE 3	ACE 5	ACE 7
Stockton	4:20AM	5:35AM	6:40AM	7:05AM
Tracy	4:51AM	6:06AM	7:11AM	7:36AM
Pleasanton	5:33AM	6:48AM	7:53AM	8:18AM
Great Am.	6:13AM	7:28AM	8:33AM	8:58AM
San Jose	6:32AM	7:47AM	8:52AM	9:17AM

EASTBOUND TRAINS

	ACE 4	ACE 6	ACE 8	ACE 10
San Jose	3:35PM	4:35PM	5:35PM	6:38PM
Great Am.	3:49PM	4:49PM	5:49PM	6:52PM
Pleasanton	4:28PM	5:28PM	6:28PM	7:31PM
Tracy	5:11PM	6:11PM	7:11PM	8:14PM
Stockton	5:47PM	6:47PM	7:47PM	8:50PM



Valley Link

Connecting People, Housing, and Jobs

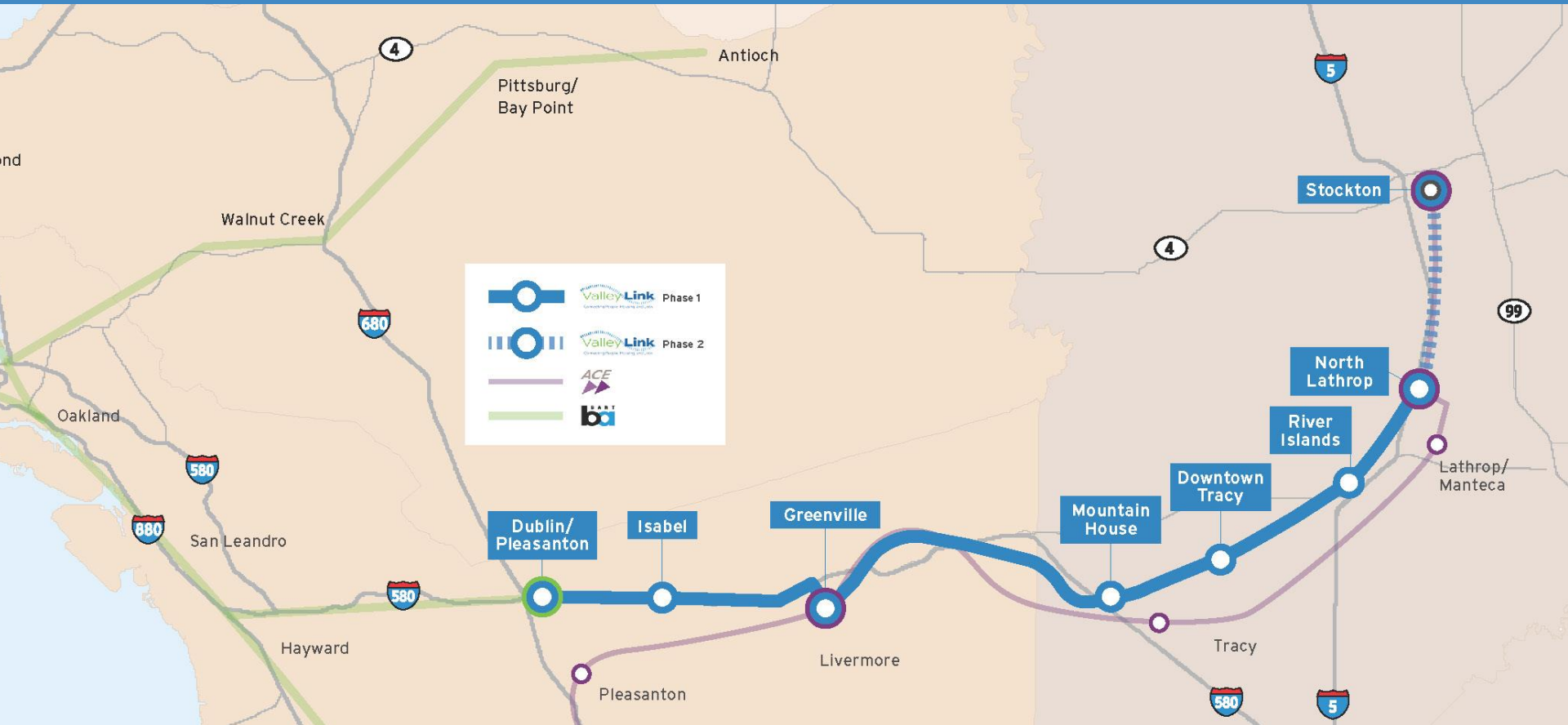

Tri-Valley & San Joaquin Valley
REGIONAL RAIL AUTHORITY

2018 California State Rail Plan 2040 Vision



Altamont Corridor Vision



More Commuters Making Megaregional Trips

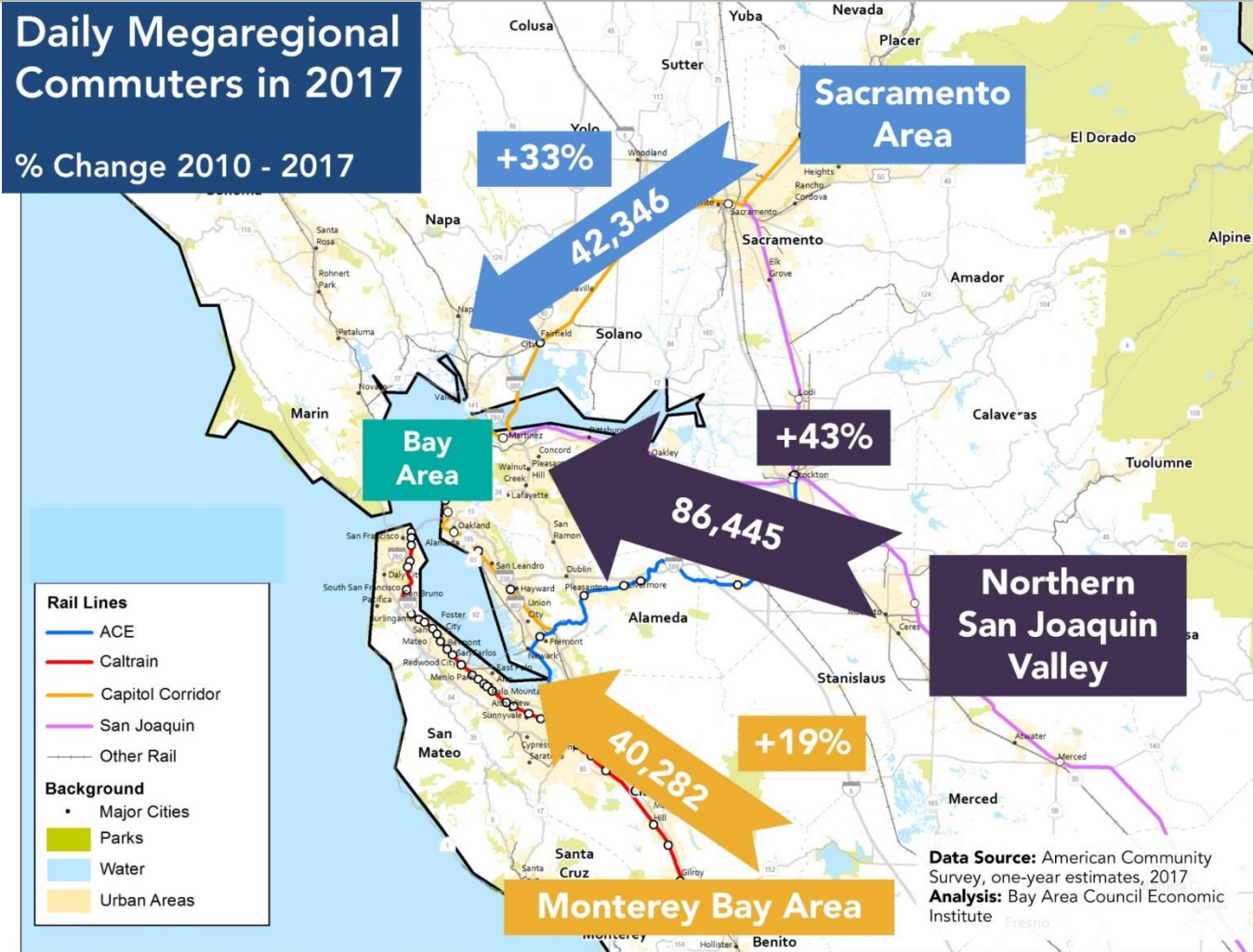

Altamont Corridor Programs

- **Short-term:**
 - 2 additional round-trips between SJV and San Jose via Altamont Pass & weekend service (6 daily round trips week days)
 - Valley Link initiated: Dublin/Pleasanton to North Lathrop
- **Mid-term:**
 - 4 more round-trips between SJV and San Jose via Altamont Pass & weekend service (10 daily round trips week days)
 - Valley Link extended to Stockton
- **Longer-term “Vision”:**
 - 15 minute to ½ hour frequency during peak periods;
 - Dedicated Track – “Universal Corridor”



Evolution of the Altamont Corridor Vision



2007 MTC Regional Rail Plan



2011 Altamont Corridor Rail Project



2018 California State Rail Plan

Altamont Corridor Vision



Invest in capacity and travel time



Est Cap Cost: ~\$6
billion

Goals

- Focus on connection between Central Valley and East Bay
- Connecting services, shared facilities, speed up to 125+
- One seat ride from Central Valley to San Jose/Peninsula/San Francisco
- Dramatically improve travel times and frequency
- Electrification, freight separation

Major Projects Lathrop to Newark:

- 1- Tracy alignment improvements
- 2- Altamont Pass Tunnel
- 3- Livermore alignment improvements
- 4- Pleasanton alignment improvements
- 5- Niles Canyon Tunnel/Fremont Improvements



Universal corridors, shared facilities

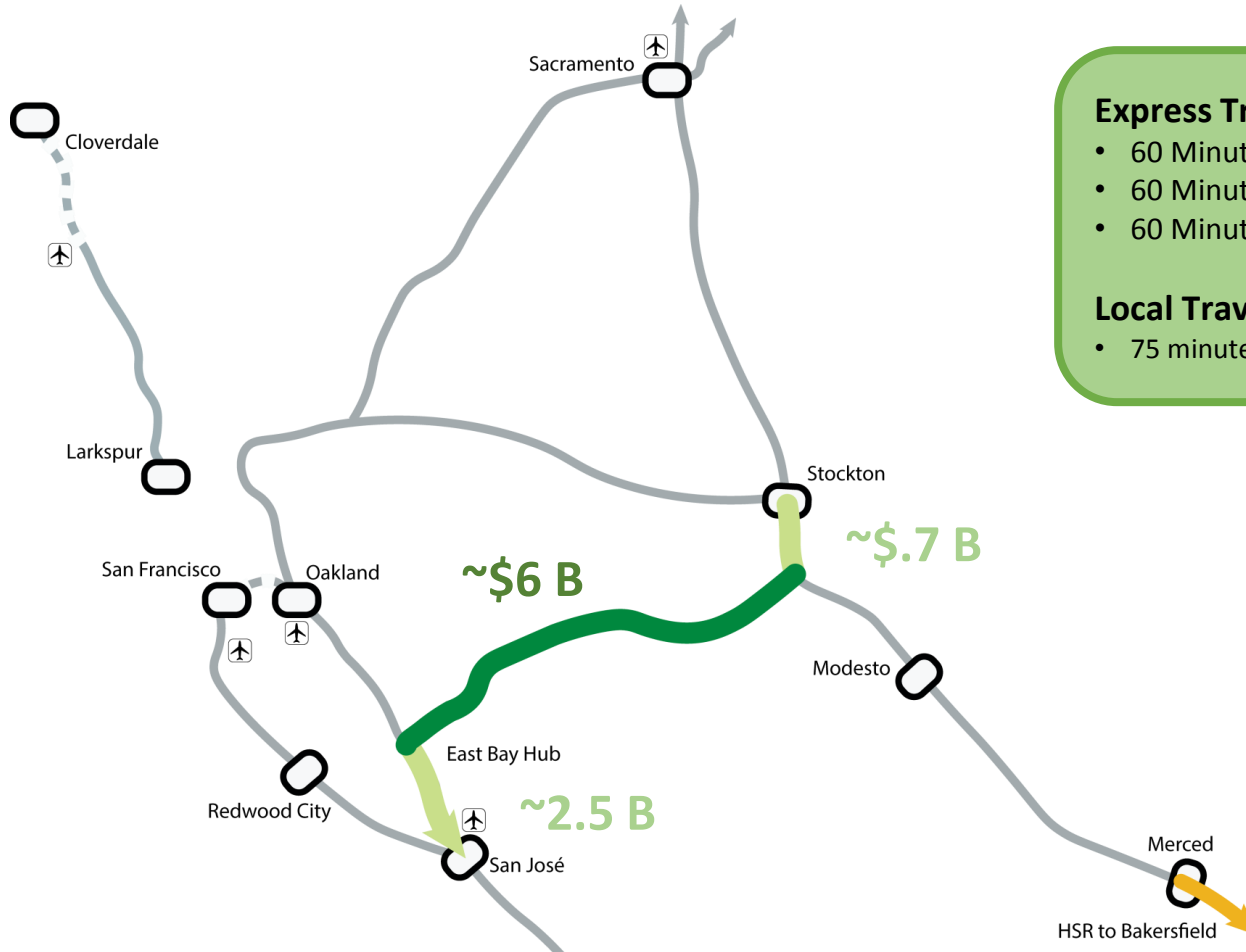

Express Travel Times – One seat ride

- 60 Minutes Stockton to San Jose
- 60 Minutes Stockton to Oakland
- 60 Minutes Stockton to Redwood City

Local Travel Times

- 75 minutes Stockton to San Jose



Universal corridors, shared facilities

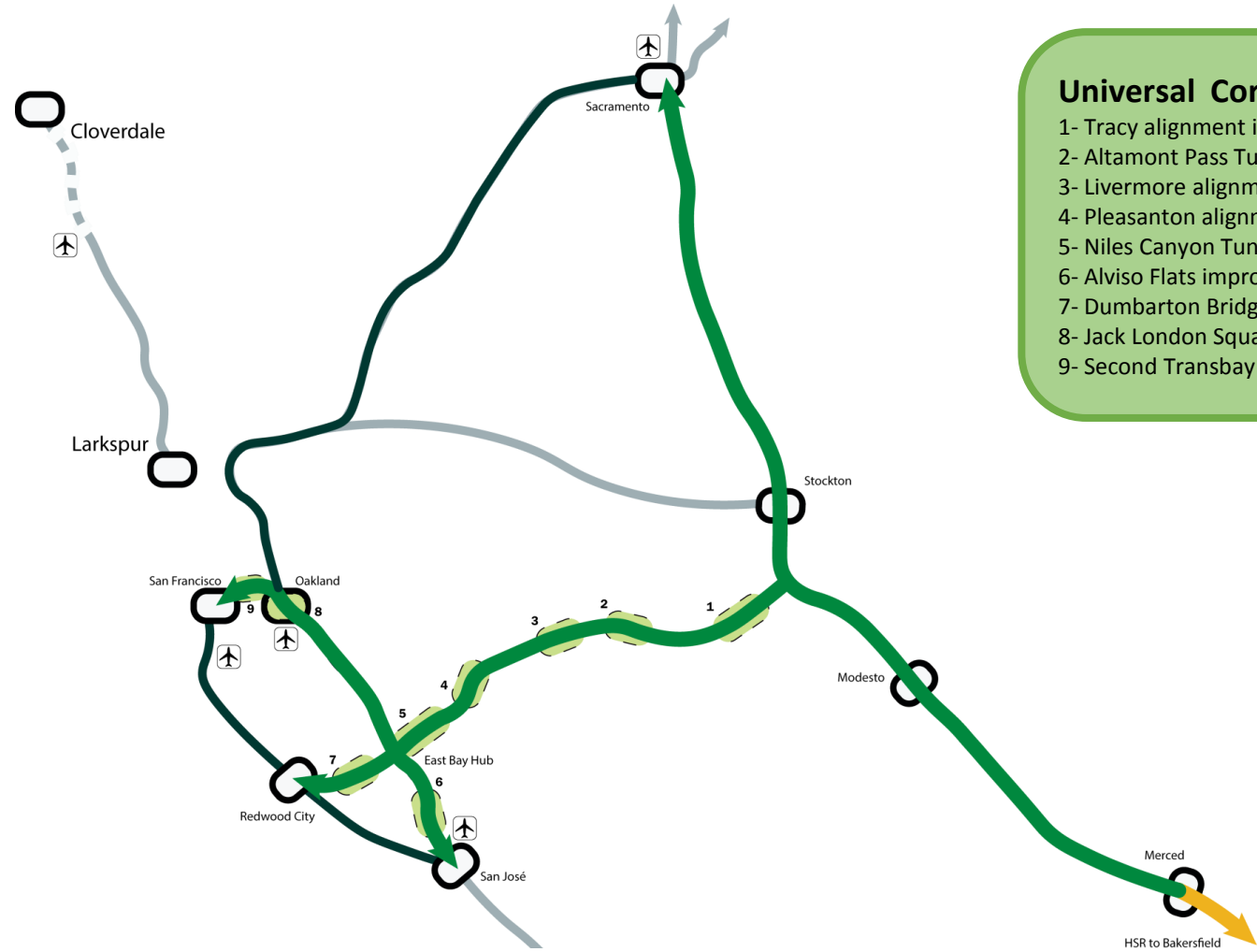

Universal Corridor Improvements:

- 1- Tracy alignment improvements
- 2- Altamont Pass Tunnel
- 3- Livermore alignment improvements
- 4- Pleasanton alignment improvements
- 5- Niles Canyon Tunnel/Fremont Improvements
- 6- Alviso Flats improvements
- 7- Dumbarton Bridge
- 8- Jack London Square improvements
- 9- Second Transbay Tube



Universal corridors, shared facilities

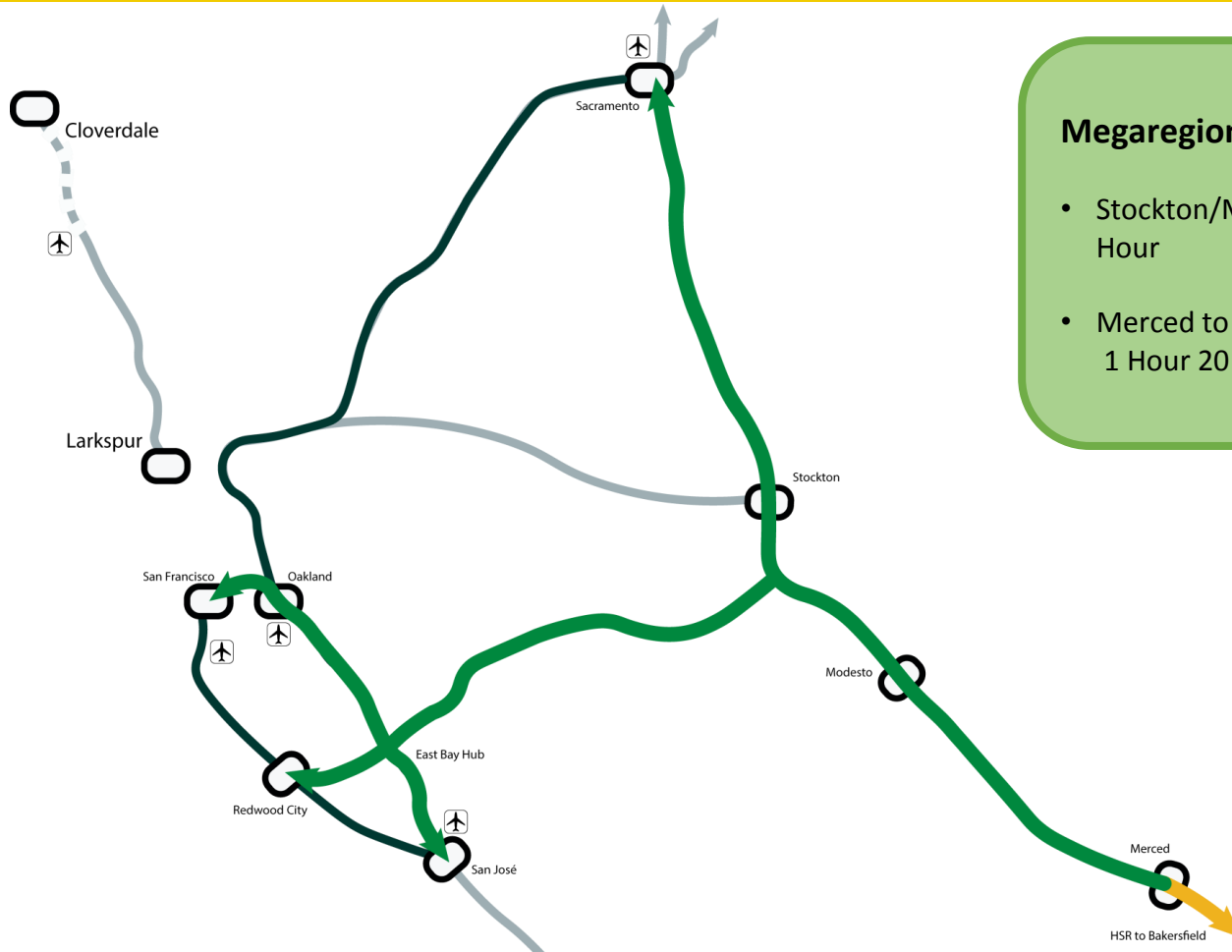

Megaregional Travel Times

- Stockton/Modesto to San Jose/Oakland/Peninsula: 1 Hour
- Merced to San Jose/Oakland/Peninsula: 1 Hour 20 minutes



Megaregional Network Integration

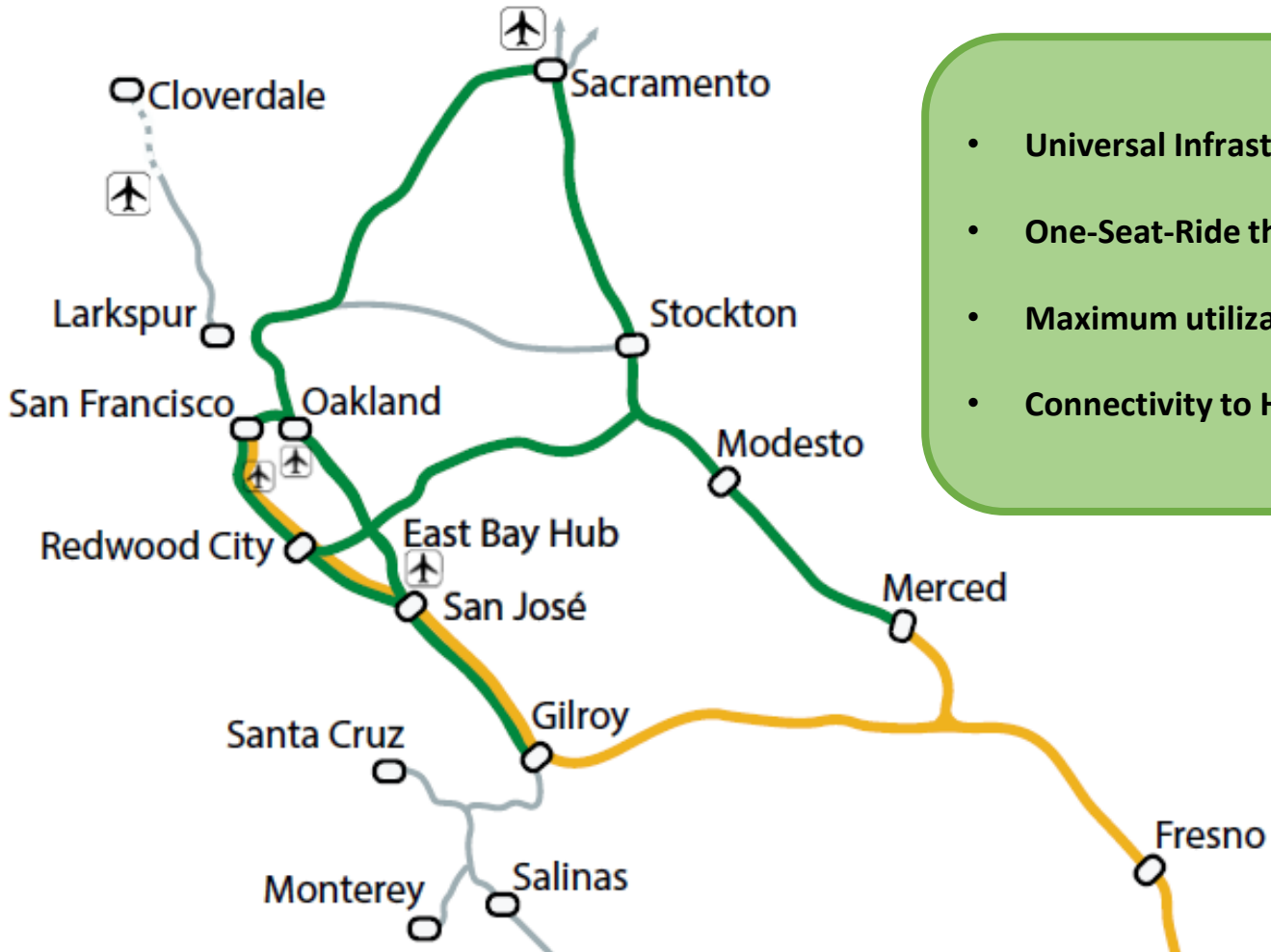

- Universal Infrastructure
- One-Seat-Ride throughout the Megaregion
- Maximum utilization of new Bay Crossings
- Connectivity to High Speed Rail

Altamont Corridor Vision



San Joaquin Valley - Sacramento Corridor

- **Short-term (funded):**
 - 7 additional round-trips between SJV and Sacramento (2 San Joaquins & 5 ACE trains)
- **Mid-term:**
 - Hourly Service + extension to Yuba City / Marysville and Oroville
- **Longer-term “Vision”**
 - Connected Corridor North: 15 minute to ½ hour frequency during peak periods; Dedicated Track – “Universal Corridor” (Sacramento to Merced)



Altamont Corridor Vision Outreach

- **Presentations:**
 - Bay Area Council Transportation Committee - April 24
 - Rail Summit – April 25
 - Central Valley Rail Working Group – April 26
 - Silicon Valley Leadership Group Trans. Committee – May 1
 - **SJRRC Board – May 3**
 - Silicon Valley Regional Rail Working Group – May 3
 - San Joaquin Valley Policy Conference – May 10
 - **Tri-Valley – San Joaquin Valley Regional Rail Authority – May 15**
 - San Joaquin COG – May 23
 - Sacramento Regional Rail Working Group – May 30
 - **SJIPA Board Meeting – May 31**
 - SPUR Forum, San Jose – June 5
- **Key Meetings:**
 - FASTER Bay Area (BAC, SVLG, SPUR, Transform)
 - MTC, ACTC: Plan Bay Area 2050
 - Northern CA MegaRegional Meetings





San Joaquin Joint Powers Authority

Item 10

SB 742 Update

Dan Leavitt

SB 742 UPDATE

- Senate Bill 742 (SB 742) was introduced by Senator Allen on February 22, 2019.
- The purpose of SB 742 is to remove portions of Section 14035.55 of the CA Government Code which require state supported Amtrak Thruway bus passengers to have a rail trip as part of their ticket.
- Senator Galgiani and Assemblymember Gray have agreed to co-author this bill and others in the Legislature are expected to sign on soon.

SB 742 UPDATE

- Amending Section 14035.55 provisions would enable the JPAs to pick up and drop off passengers on their Amtrak intercity thruway bus routes without requiring them to have a train ticket as part of their trip.
- Amending Section 14035.55 provisions would:
 - Increase revenues for the state at virtually no additional cost
 - Provide improved access to priority and underserved communities
 - Reduce the amount of greenhouse gases and air pollution emissions, better utilize infrastructure and reduce congestion.

SB 742 UPDATE

- On April 23, SB 742 passed through the Senate Transportation Committee with a **12-0** vote.
- On May 6, SB 742 passed through Senate Appropriations.
- SB 742 passed on the Senate Floor with a **37-0** vote on May 20, 2019
- The bill is expected to be heard by the Assembly Transportation Committee in June.
- It then would go to Assembly Appropriations before going to the Assembly Floor.

SB 742 UPDATE

- Staff has been working with Senator Allen's office and RailPac on SB 742.
 - Staff were a witness in favor of SB 742 at the Senate Transportation Committee Hearing on April 23
 - Provided a join response with RailPac to the letter of opposition from the CA Bus Association.
 - Staff is working with Senator Allen's office on potential amendments to SB 742.
 - Developed "Fact Sheet"



San Joaquin Joint Powers Authority

Item 11

High Speed Rail Project Update Report

Stacey Mortensen

CHSRA Project Update Report

- In July 2012, the California Legislature approved—and Governor Brown signed into law—Senate Bill 1029 (Budget Act of 2012).
 - SB 1029 appropriated almost \$8 billion in federal and state funds to construct the first high-speed rail segments in the Central Valley and to fund 15 bookend and connectivity projects throughout California.
- On May 1st, 2019 California High-Speed Rail Authority's (CHSRA) released its 2019 Project Update Report (PUR).
 - This report fulfills the Authority's biennial requirement to update the California Legislature on the development and implementation of intercity high-speed rail service.

CHSRA Project Update Report

- This 2019 Project Update Report provides comprehensive reviews of:
 - ▣ Progress made on the high-speed rail project since the 2017 Project Update Report
 - ▣ Project updates since the 2018 Business Plan
 - ▣ What was learned in the months since the 2018 Business Plan was published

- The focus of the PUR is the decision by the CHSRA to begin initial operations on the high-speed rail infrastructure with a Merced-Fresno-Bakersfield high-speed rail service (with stops in Madera and Kings/Tulare)
 - ▣ Future integration with existing San Joaquins and ACE rail services in Merced and with San Joaquins Thruway Bus connections in Bakersfield

CHSRA Project Update Report

- With Central Valley high-speed rail infrastructure and opportunity for early interim service, SJJPA/SJRRC staff will be working closely with the Authority to evaluate options for integrated service plans

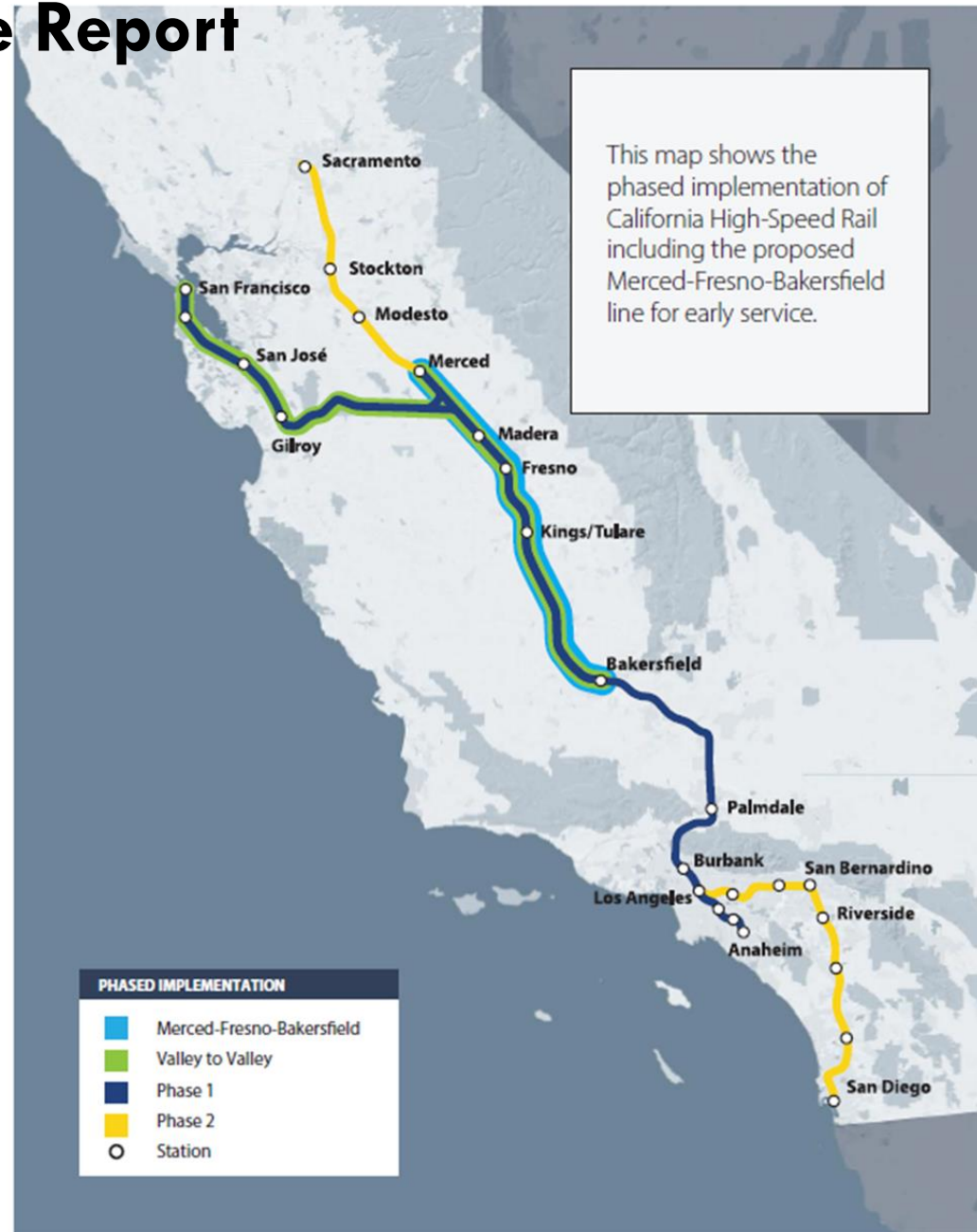

CHSRA Project Update Report

Staff has suggested:

- New ridership modeling that includes the timed transfers to ACE and San Joaquins in Merced
- Evaluation of service options south of Merced that don't compete with HSR services (Feeder, Regional, etc.)

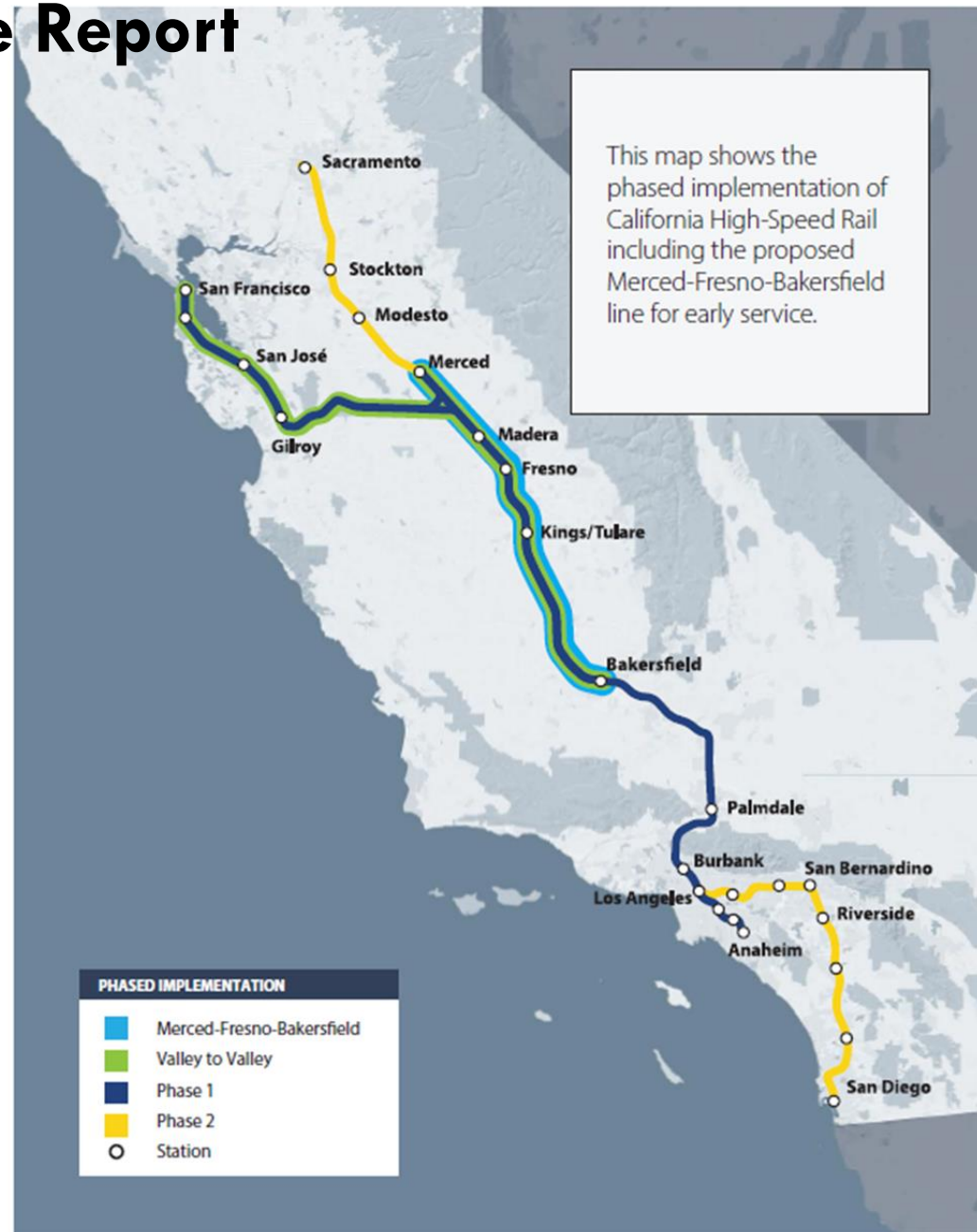

CHSRA Project Update Report

Staff has suggested:

- A review of a lighter infrastructure build into Merced and Bakersfield, given funding limitations
- More information sharing

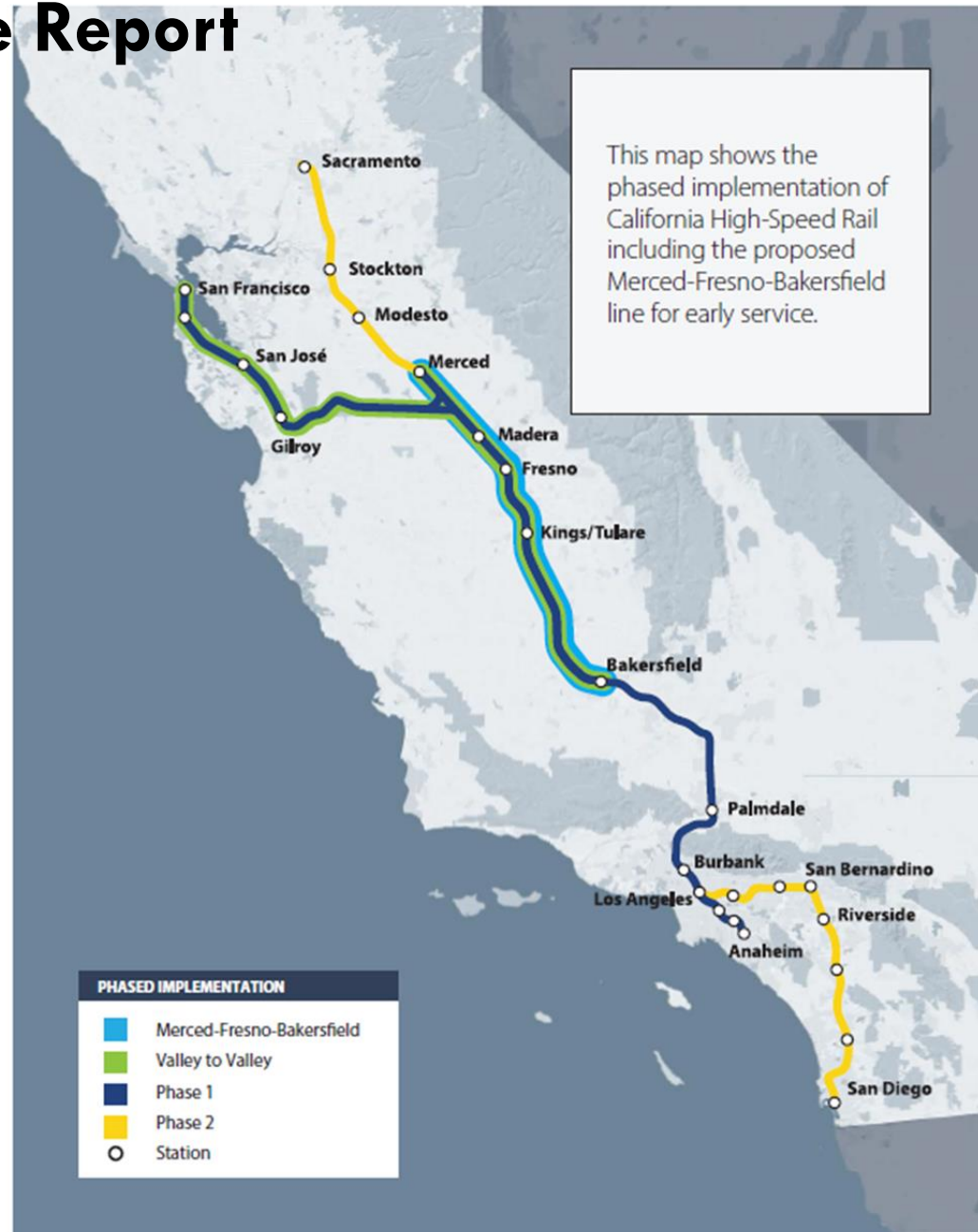



San Joaquin Joint Powers Authority

Item 12

Trip Report on Ag Day

Carmen Setness



San Joaquin Joint Powers Authority

Item 13

Marketing and Outreach Update

David Lipari/ Tom Van der List

AMTRAK

SAN JOAQUINSSM

Connecting you to California

GRASSROOTS OUTREACH UPDATE
Tom van der List – KP Public Affairs
5/31/2019



Marketing and Outreach Update

About our Program

- **Objective:** Conduct grassroots outreach with the goal of raising awareness of the San Joaquins service in order to boost ridership
- **How We Work to Meet This Objective**
 - Stakeholder engagement
 - Information booths
 - Materials development/social & digital content
 - Toolkit deployment
 - Strategic Partnerships
 - Trade advertising to audiences
 - Social/digital content
 - Media relations
 - Press Releases
 - Opinion Editorials



Information Booths

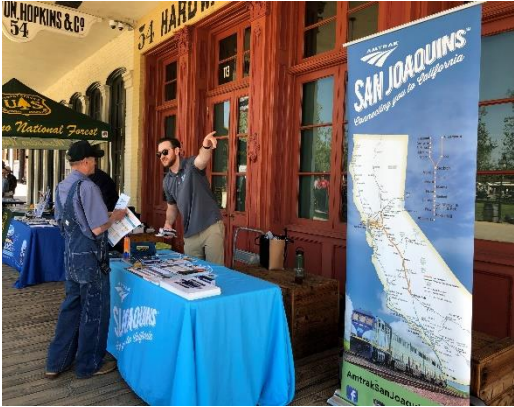

AMTRAK
SAN JOAQUINSSM
Connecting you to California

Information Booths

Information booths held in the last year

- Sacramento Great Train Show – January 2019
- Stockton Chinese New Year Celebration – March 2019
- Fresno Pacific University – March 2019
- Fresno City College – March 2019
- Stockton Earth Day – April 2019
- Earth Day Community Event at Radio Park (Fresno) – April 2019
- 2-Day Vintage Days at Fresno State – April 2019
- Redding Bus-ta-move Whole Earth and Watershed Festival – April 2019
- Sacramento Earth Day – April 2019
- Fiesta en la Calle – May 2019
- Thursday Night Marketplace (Hanford) – May 2019
- 150th Transcontinental Railroad Celebration (Sacramento) – May 2019
- Sacramento County Fair – May 2019



Group trips

WOW Museum (Lodi)

- Escorted and filmed a group of 25+ students who traveled to Lodi to experience the WOW Museum.

Allensworth Rededication Event

- Coordinated outreach efforts for individuals to reserve group trips to Allensworth Rededication event.

Ag Day at the Capitol

- Conducted outreach and facilitated day-trip for over 150 students and chaperones to attend Ag Day in Sacramento.



Materials Development



California Everyday Discounts for Seniors, Veterans, Passengers with Disabilities, and Students

EXPLORE CALIFORNIA WITH THESE GREAT DISCOUNTS



Descuentos diarios en California para Personas Mayores, Veteranos, Pasajeros con Discapacidades y Estudiantes

¡EXPLORA CALIFORNIA CON ESTOS GRANDES DESCUENTOS!

In January of 2018, Amtrak® San JoaquinsSM launched new "California Everyday Discounts" promotional codes that Seniors, Passengers with Disabilities, and Students can utilize to maintain access to valuable cost savings. This California Everyday Discounts program was developed by Amtrak San Joaquins in coordination with California's two other Intercity rail services, the Capitol Corridor and Pacific Surfliner.

When booking your next ticket on AmtrakSanJoaquins.com, use these codes:

<p>15% SENIOR DISCOUNT</p> <ul style="list-style-type: none"> Select "Adult" as your passenger type Enter the code V282 in the promo code field 	<p>15% DISABLED PASSENGER DISCOUNT</p> <ul style="list-style-type: none"> Select "Adult" as your passenger type Enter the code V577 in the promo code field 	<p>15% STUDENT DISCOUNT</p> <ul style="list-style-type: none"> Select "Adult" as your passenger type Enter the code V353 in the promo code field 	<p>15% VETERANS DISCOUNT</p> <ul style="list-style-type: none"> Select "Adult" as your passenger type Enter the code V430 in the promo code field
---	---	--	---

You may also use these codes to receive your discount when booking via 1-800-USA-RAIL, at a staffed station, or at a Quik-Trak kiosk.

Other Discounts Remain the Same on the San Joaquins:

<p>FRIENDS AND FAMILY</p> <ul style="list-style-type: none"> Buy one ticket and save 50% on up to five companion fares Available every day with a one-day advance purchase Enter the code V302 in the promo code field 	<p>GROUP DISCOUNTS</p> <ul style="list-style-type: none"> Groups may be eligible to receive discounts for each passenger in groups as small as 20 passengers The half-fare children's discounts may be applied to eligible members of the group Book early by calling 1-800-USA-1GRP or emailing groupsales@amtrak.com. 	<p>OTHER AVAILABLE DISCOUNTS</p> <ul style="list-style-type: none"> Children ages 2-12 ride half price; infants ride free. Limited to one child per adult Military personnel and families save 10% NARP Members save 10% No codes needed
---	--	---

You may also use these codes to receive your discount when booking via 1-800-USA-RAIL, at a staffed station, or at a Quik-Trak kiosk. Learn more at <https://www.amtrak.com/california-everyday-discounts>

Some restrictions apply. Amtrak Policies, fares, schedules and rates are subject to change without notice.

En enero de 2018, Amtrak® San JoaquinsSM lanzó nuevos códigos promocionales de "Descuentos Diarios de California" para que las personas mayores, los pasajeros con discapacidades y los estudiantes puedan seguir teniendo acceso a importantes ahorros. Este programa fue desarrollado por Amtrak San Joaquins en coordinación con otros dos servicios ferroviarios interurbanos de California, el Capitol Corridor y Pacific Surfliner.

Cuando haga su próxima reservación en AmtrakSanJoaquins.com, use estos códigos:

<p>15% DE DESCUENTO PARA PERSONAS MAYORES</p> <ul style="list-style-type: none"> Seleccione "Adulto" para su tipo de pasajero Teclée el Código V282 en el espacio del Código promocional 	<p>15% DE DESCUENTO PARA PASAJEROS DISCAPACITADOS</p> <ul style="list-style-type: none"> Seleccione "Adulto" para su tipo de pasajero Teclée el Código V577 en el espacio del Código promocional 	<p>15% DE DESCUENTO PARA ESTUDIANTES</p> <ul style="list-style-type: none"> Seleccione "Adulto" para su tipo de pasajero Teclée el Código V353 en el espacio del Código promocional 	<p>15% DE DESCUENTO PARA VETERANOS</p> <ul style="list-style-type: none"> Seleccione "Adulto" para su tipo de pasajero Teclée el Código V430 en el espacio del Código promocional
--	--	---	---

También puede usar estos códigos para recibir su descuento al reservar a través de 1-800-USA-RAIL, en una estación con personal o en un quiosco de Quik-Trak.

Otros descuentos siguen siendo los mismos en el SJP:

<p>AMIGOS Y FAMILIARES</p> <ul style="list-style-type: none"> Compra un boleto y ahorre un 50% en hasta cinco pasajes para acompañantes Disponible todos los días comprando con un día de anticipación Teclée el Código V302 en el espacio del Código promocional 	<p>DESCUENTOS DE GRUPO</p> <ul style="list-style-type: none"> Los grupos pueden ser elegibles para recibir descuentos para cada pasajero aún para grupos pequeños de 20 pasajeros Los descuentos para niños a mitad de precio se pueden aplicar a los miembros elegibles del grupo Reserve con tiempo llamando 1-800-USA-1GRP o enviando un correo electrónico groupsales@amtrak.com. 	<p>OTROS DESCUENTOS DISPONIBLES</p> <ul style="list-style-type: none"> Los niños de 2 a 12 años de edad viajan a mitad de precio; los bebés viajan gratis. Limitado a un niño por adulto. Personal militar y familias ahorran un 10% Miembros de NARP ahorran un 10% No se necesitan códigos
--	--	---

También puede usar estos códigos para recibir su descuento al reservar a través de 1-800-USA-RAIL, en una estación con personal o en un quiosco de Quik-Trak.

Más información en <https://www.amtrak.com/california-everyday-discounts>

Se aplican algunas restricciones, las políticas, pasajes, horarios y tarifas de AMTRAK están sujetos a cambios sin previo aviso.

AmtrakSanJoaquins.com 

Espanol.Amtrak.com 



Social and digital content

 **Amtrak San Joaquins**
January 17 · 🌐

Looking for a family-friendly activity? Interactive exhibits await at the World of Wonders Science Museum, located just a two-minute walk from our train station in Lodi. Bring the entire family, and save on travel with our Friends & Family Discount. #AmtrakSanJoaquins #ConnectingCalifornia





AMTRAK.COM [Book Now](#)

World of Wonders Science Museum

👍❤️ 133 13 Comments 65 Shares



 **amtrak-sanjoaquins** · [Follow](#) ...

 **squintycub Bakersfield!**
38w 3 likes Reply
— View replies (1)

 **amtrak_and_awvr_fan Bakersfield!**
38w 3 likes Reply
— View replies (1)

 **oakland.ca.local 📍**
38w 1 like Reply

 **bnsffan453 Bakersfield**
38w 2 likes Reply
— View replies (1)

👍💬📤 📖

153 likes
SEPTEMBER 2, 2018

Log in to like or comment.



Social and digital content

Amtrak San Joaquins
 Published by Alejandra Garcia [?] · May 13 at 8:00 PM · 🌐

We have a winner! Congrats to Colleen Byars from Stockton on winning the popular vote in our #ConnectingYouToCA photo contest! If this is how excited your little one was just to be on the train, imagine how excited he will be to learn that you're getting a round trip to Los Angeles on Amtrak San Joaquins, complete with tickets to a Dodgers vs Giants game and a hotel stay. We can't wait to hear all about it!



2,282 People Reached **396** Engagements [Boost Post](#)

👍❤️ 141 15 Comments 14 Shares

Amtrak San Joaquins
 Published by Alejandra Garcia [?] · May 24 at 11:31 AM · 🌐

Congrats to Dulce from Bakersfield on winning the judges vote in our #ConnectingYouToCA Photo Contest! We hope you enjoy your grand prize trip to Los Angeles, and we look forward to having you back on board!
 Thanks to the [Fresno Chamber of Commerce](#), [Sacramento Metro Chamber](#) and the [Richmond Chamber of Commerce](#) for being our judges.



Get More Likes, Comments and Shares ✕
 This post is performing better than 95% of other posts on your Page. Boost it to get more great results.

2,225 People Reached **221** Engagements [Boost Post](#)

👍❤️👎 128 6 Comments 12 Shares



Disadvantaged Communities

- Develop and implement strategies to reach disadvantaged communities in novel ways
 - Market outreach, develop relationships with cultural groups, etc.
- La Esperanza Mexican Food Products
- Toledo's Market
- Superior Supermercados
- Superior Market
- Victoria Mercado y Carniceria (2)
- Tierra Carniceria
- Mi Rancho
- Tapatio Brothers
- La Popular Super Market
- Viva Supermarket (2)
- Tinoco's Meat Market

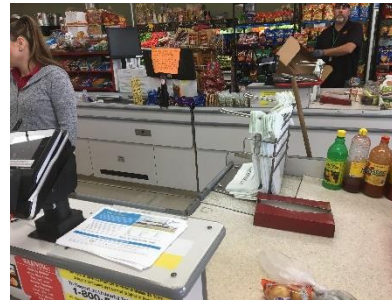

Toolkit deployment

- To amplify messages, the team develops and deploys a kit of parts, including social media messages, newsletter/eblast content, and printable flyers.



Toolkit deployment



Select Language

SEARCH

ABOUT US

OUR WORK

GET INVOLVED

BLOG & RESOURCES

DONATE

Home » Get Involved » Events » Take the Train to Allenstown Juneteenth

JUN 8

Take the Train to Allenstown Juneteenth

Time: 10:00 am

<http://friendsofallensworth.com/calendar/>

Take Action

Email Sign-Up

Our Blog

Juneteenth is the oldest known celebration of the ending of slavery. It was on June 19th that the Union soldiers, led by Major General Gordon Granger, landed at Galveston, Texas with news that the war had ended and that all slaves were now free. This was two and a half years after President Lincoln's Emancipation Proclamation, which had become official on January 1, 1863. This day is celebrated in honor of the African Americans who received notice of being set free on June 19, 1865.

Allenstown is a Central Valley town founded by former slaves and their families. Friends of Allenstown's annual celebration features entertainment, speakers, food, and free tours of the historic buildings.

Amtrak San Joaquins is offering group and family discounts to get to the celebration.



AMTRAK
SAN JOAQUINSSM
Connecting you to California

Toolkit deployment



2019
CAPITOL BEER FEST
SATURDAY • MARCH 2 • 12-4pm

Other Hoppy Info

- FREE Bike Valet available, provided by [SABA](#)
- [Light Rail](#) to Sacramento Valley Station at 7th and Capitol
- [Food](#) available for purchase from 20 Vendors
- All proceeds benefit local non-profit [Runnin' for Rhett](#) Foundation – Federal Tax ID# 26-1419222
- More good info on the [Logistics](#) and [FAQ](#) pages
- Amtrak San Joaquin arrives at the Sac Valley Station at 11:15 am



Capitol Beer Fest

March 1 · 🌐

Final reminder! If you are traveling to the Capitol Beer Fest, the Amtrak San Joaquins arrives and departs a short walk from the Capitol Mall. Skip the traffic and the parking! You can book your tickets at <https://www.amtrak.com/san-joaquins-train>. Be sure to check for discounts here <https://www.amtrak.com/california-everyday-discounts>. #BeersOnCap #CBF2019



👍 4



AMTRAK
SAN JOAQUINSSM
Connecting you to California

Strategic Partnerships

- CA Railroad Museum
- WOW Museum
- Comstocks Magazine
- CA Hispanic Chamber of Commerce
- Hyatt Regency
- Regional Events (last)
- Modesto Symphony
- Downtown Fresno Partnership
- Fresno Chamber of Commerce
- Hanford Chamber of Commerce
- Visit Bakersfield

COMSTOCK'S
 2335 American River Dr., Ste 301
 Sacramento, CA 95825

TRADE INVOICE

DATE	INVOICE NO.
1/9/2019	CT611822

CLIENT
 TOM VAN DER LIST
 KP PUBLIC AFFAIRS
 621 CAPITOL MALL STE 1900
 SACRAMENTO CA 95814

ISSUE	TERMS	REP	PROJECT
January 2019	Net 30	KR	
DESCRIPTION	QTY	RATE	AMOUNT
January 2019 - 1/4 page trade advertisement for Comstock's Magazine being placed on Amtrak San Joaquin for 2019		2,100.00	2,100.00
January Web Advertising		400.00	400.00
TOTAL			\$2,500.00

TRADE INVOICE
 DO NOT PAY



Strategic Partnerships

RIDE AMTRAK SAN JOAQUINS AND

SAVE 10%

ON YOUR STAY AT THE HYATT REGENCY IN SACRAMENTO



AMTRAK SAN JOAQUINS

 Sacramento Hispanic Chamber of Commerce
May 8 at 8:45 AM · 🌐

Amtrak San Joaquins has a new partnership with the Hyatt Regency @HyattRegencySacramento in Sacramento! What does that mean for you? 10% off your hotel stay when you take the Amtrak San Joaquins @amtraksanjoaquins train into town.

Book your hotel and travel arrangements today! Access the discount offer by entering the code CR123796 at Hyatt.com under "Corporate or Group Code" or reference "Amtrak San Joaquins" when booking by phone.

RIDE AMTRAK SAN JOAQUINS AND

SAVE 10%

ON YOUR STAY AT THE HYATT REGENCY IN SACRAMENTO



AMTRAK SAN JOAQUINS



SAN JOAQUINSSM

Connecting you to California

Media relations

- The team maintains relationships with media contacts likely to cover transportation related subjects.
 - Op-eds (morning express)
 - Press Releases
 - Coordinate interviews



TRAVEL

Amtrak San Joaquins makes schedule changes to improve SoCal connectivity & on-time performance

Amtrak San Joaquins schedule changes will improve connectivity across the Bay Area, Sacramento, the San Joaquin Valley and Southern California.

Author: Carlos Herrera
Published: 12:07 PM PDT May 20, 2019
Updated: 12:07 PM PDT May 20, 2019

SACRAMENTO, Calif. — Amtrak San Joaquins is making some schedule changes to make it easier and faster for passengers to get to their destinations.

The overall goal is to improve on-time performance, enhance statewide connectivity, and make rail travel convenient for the greatest number of travelers.



Thank you!

Contact info

tvanderlist@ka-pow.com

530-400-2763





San Joaquin Joint Powers Authority

Item 14

Executive Director's Report

Stacey Mortensen



San Joaquin Joint Powers Authority

Item 15

Board Members Comments

Chair Chiesa



San Joaquin Joint Powers Authority

Item 16

Adjournment

Chair Chiesa



San Joaquin

Joint Powers Authority

May 31, 2019 Board Meeting