

*Artistry in Sound*  
**ONKYO®**

# **T-407**

**Quartz Synthesized FM Stereo/AM Tuner**

**Instruction Manual**

• *Congratulations on your purchase of the ONKYO T-407 Tuner.* • *Please read this manual thoroughly before making connections and turning power on.* • *Following the instructions in this manual will enable you to obtain optimum performance and listening enjoyment from your new T-407.* • *Please retain this manual for future reference.*

## CONTENTS

Features .....	1
Important safeguards.....	1
Precautions.....	2
Supplied accessories.....	2
System connections.....	2
Front panel facilities.....	4
Operations.....	5
Trouble-shooting guide.....	7
Specifications.....	7

## Features

### • Isohex Power Supply

ONKYO's exclusive Isohex Power Supply arranges the six main tuner circuits like the spokes of a wheel around a central power supply hub. Independent supply and ground lines run from the power supply to each of the tuner circuits: to the display, to the quartz synthesizer, to the front end, to the IF, to the FM PLL demodulator, and to the stereo MPX. By minimizing the distance between the power supply and each circuit, this arrangement improves power supply control. By isolating the routes to the circuits, it also avoids interference.

### • Outstanding Sensitivity and Tuning Precision

One major reason for the T-407's excellent sensitivity and tuning precision is its RF section which uses five varactor diodes "ganged" through the single tuning voltage source. This uncompromising design, coupled with MOS FETs and a dual local oscillator buffer, gives the T-407 the sharp, precise reception listeners expect from an ONKYO tuner.

### • 40-Station FM/AM Random Preset Tuning

### • Classified Memory Preset

On the T-407 the memory presets are organized into eight classes designated A-H. Each class can be assigned to a different type of program material or a different member of the family. You can preview the stations in any particular class at the touch of a button.

### • Direct Access Tuning

Instead of using the UP or DOWN tuning keys to scan through the available frequencies until the desired station is located, Direct Access Tuning lets you punch in the broadcast frequency directly using the 10 numeric keys. For example, to select 103.5 MHz the user simply presses the 1, 0, 3, 5 and 0 keys.

### • APR (Automatic Precision Reception) System

### • Naming stations using 5 characters, 40 stations in total

### • Front End Designed to Minimize Intermodulation Distortion

### • 25 kHz FM Tuning Steps

### • 10-Segment Signal Strength Indicator

### • RI Remote Control System Compatible

## CAUTION:

"TO REDUCE THE RISK OF ELECTRIC SHOCK, DO NOT REMOVE COVER (OR BACK). NO USER-SERVICEABLE PARTS INSIDE. REFER SERVICING TO QUALIFIED SERVICE PERSONNEL."



**CAUTION**  
RISK OF ELECTRIC SHOCK  
DO NOT OPEN



- The lightning flash with arrowhead symbol, within an equilateral triangle, is intended to alert the user to the presence of uninsulated "dangerous voltage" within the product's enclosure that may be of sufficient magnitude to constitute a risk of electric shock to persons.



- The exclamation point within an equilateral triangle is intended to alert the user to the presence of important operating and maintenance (servicing) instructions in the literature accompanying the appliance.

## "WARNING"

"TO REDUCE THE RISK OF FIRE OR ELECTRIC SHOCK, DO NOT EXPOSE THIS APPLIANCE TO RAIN OR MOISTURE."

- For models having power cord with a polarized plug.

### CAUTION:

TO PREVENT ELECTRIC SHOCK, MATCH WIDE BLADE OF PLUG TO WIDE SLOT, FULLY INSERT.

- Sur les modèles dont la fiche est polarisée.

### ATTENTION:

POUR EVITER LES CHOCES ELECTRIQUES, INTRODUIRE LA LAME LA PLUS LARGE DE LA FICHE DANS LA BORNE CORRESPONDANTE DE LA PRISE ET POUSSER JUSQU' AU FOND.

## Important safeguards

1. **Read Instructions** – All the safety and operating instructions should be read before the appliance is operated.
  2. **Retain Instructions** – The safety and operating instructions should be retained for future reference.
  3. **Heed Warnings** – All warnings on the appliance and in the operating instructions should be adhered to.
  4. **Follow Instructions** – All operating and use instructions should be followed.
  5. **Water and Moisture** – The appliance should not be used near water – for example, near a bathtub, washbowl, kitchen sink, laundry tub, in a wet basement, or near a swimming pool, and the like.
  6. **Carts and Stands** – The appliance should be used only with a cart or stand that is recommended by the manufacturer.
- 6A. An appliance and cart combination should be moved with care. Quick stops, excessive force, and uneven surfaces may cause the appliance and cart combination to overturn.



S3125A

7. **Wall or Ceiling Mounting** – The appliance should be mounted to a wall or ceiling only as recommended by the manufacturer.
8. **Ventilation** – The appliance should be situated so that its location or position does not interfere with its proper ventilation. For example, the appliance should not be situated on a bed, sofa, rug, or similar surface that may block the ventilation openings; or, placed in a built-in installation, such as a bookcase or cabinet that may impede the flow of air through the ventilation openings.
9. **Heat** – The appliance should be situated away from heat sources such as radiators, heat registers, stoves, or other appliances (including amplifiers) that produce heat.
10. **Power Sources** – The appliance should be connected to a power supply only of the type described in the operating instructions or as marked on the appliance.
11. **Polarization** – If the appliance is provided a polarized plug having on blade wider than the other, please read the following information: The polarization of the plug is a safety feature. The polarized plug will only fit the outlet one way. If the plug does not fit fully into the outlet, try reversing it. If there is still trouble, the user should seek the services of a qualified electrician. Under no circumstances should the user attempt to defeat the polarization of the plug.
12. **Power-Cord Protection** – Power-supply cords should be routed so that they are not likely to be walked on or pinched by items placed upon or against them, paying particular attention to cords at plugs, convenience receptacles, and the point where they exit from the appliance.

## Precautions

### 1. Warranty Card

The serial number is written on the rear panel of this unit. Copy the serial number and model number onto your warranty card and keep it in a safe place.

## Supplied Accessories

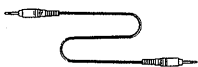

RI remote control cable × 1

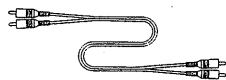

Output signal cord × 1

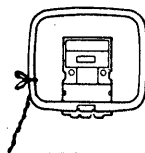

AM loop antenna × 1

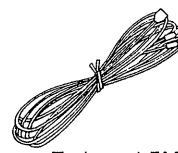

T-shaped FM antenna × 1

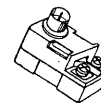

Antenna adapter × 1

13. **Cleaning** – The appliance should be cleaned only as recommended by the manufacturer.
14. **Power Lines** – An outdoor antenna should be located away from power lines.
15. **Nonuse Periods** – The power cord of the appliance should be unplugged from the outlet when left unused for a long period of time.
16. **Object and Liquid Entry** – Care should be taken so that objects do not fall and liquids are not spilled into the enclosure through openings.
17. **Damage Requiring Service** – The appliance should be serviced by qualified service personnel when:
  - A. The power-supply cord or the plug has been damaged; or
  - B. Objects have fallen, or liquid has been spilled into the appliance; or
  - C. The appliance has been exposed to rain; or
  - D. The appliance does not appear to operate normally or exhibits a marked change in performance; or
  - E. The appliance has been dropped, or the enclosure damaged.
18. **Servicing** – The user should not attempt to service the appliance beyond that described in the operating instructions. All other servicing should be referred to qualified service personnel.
19. **Outdoor Antenna Grounding** – If an outside antenna is connected to the receiver, be sure the antenna system is grounded so as to provide some protection against voltage surges and built-up static charges. Article 810 of the National Electrical Code, ANSI/NFPA 70, provides information with regard to proper grounding of the mast and supporting structure, grounding of the lead-in wire to an antenna discharge unit, size of grounding conductors, location of the antenna-discharge unit, connection to grounding electrodes, and requirements for the grounding electrode. See Figure 73.1.

**FIGURE 73.1:**  
**EXAMPLE OF ANTENNA GROUNDING AS PER NATIONAL ELECTRICAL CODE**

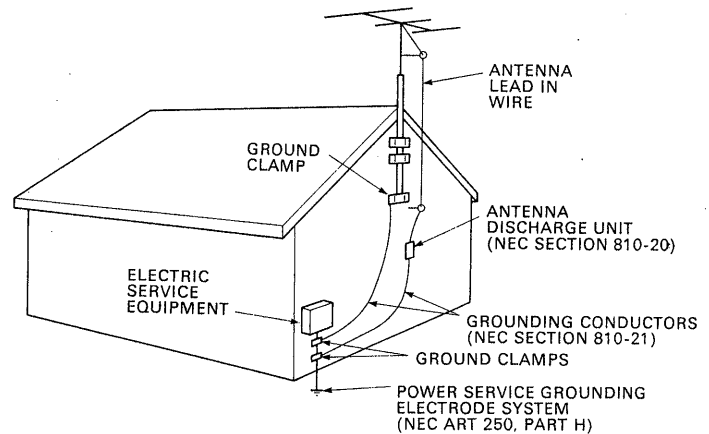

NEC – NATIONAL ELECTRICAL CODE

S2898A

### 2. Care

From time to time you should wipe off the front and rear panels and the cabinet with a soft cloth. For heavier dirt, dampen a soft cloth in a weak solution of mild detergent and water, wring it out dry, and wipe off the dirt. Following this, dry immediately with a clean cloth. Do not use rough material, thinners, alcohol or other chemical solvents or cloths since these could damage the finish or remove the panel lettering.

## System connections

- Do not connect the power cord until all other connections have been made.

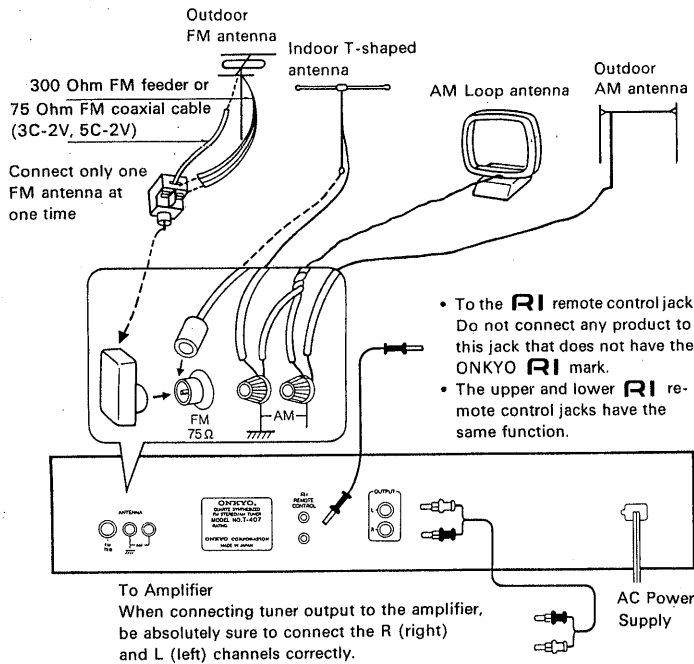

### Note to CATV system installer:

This reminder is provided to call the CATV system installer's attention to Article 820-40 of the NEC, which provides guidelines for proper grounding and, in particular, specifies that the cable ground shall be connected to the grounding system of the building, as close to the point of cable entry as practical.

### How to connect a 75/300 Ohm antenna adapter (included)

#### ■ Connecting coaxial cable

- With your fingernail or a small screwdriver, press the stopper inwards and remove the cover.
- Prepare the coaxial cable as shown below.
- Connect the 75/300 Ohm antenna adapter to the coaxial cable

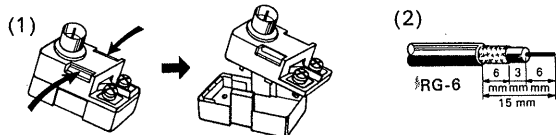

- Remove the red cord.
- Insert the end of the cable.

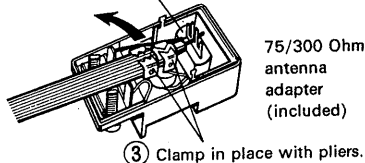

#### ■ Connecting T-shaped FM antenna or 300 Ohm FM outdoor antenna

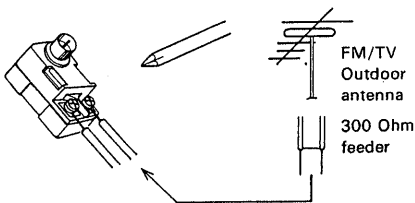

## FM Antenna Connections

Depending on the strength and quality of FM signals in your area, the accessory T-shaped antenna may give satisfactory reception or you may need an external FM antenna. To use the T-shaped antenna, spread the antenna on a wall, preferably outside or on the ceiling, and try several positions to determine which gives the best reception. If reception with the T-shaped antenna is unsatisfactory, install a multi-element external FM antenna. Consult your ONKYO Service Center about the right type for your area.

### NOTES:

- Do not use the same antenna for both FM and TV (or VCR) reception since the FM and TV (or VCR) signals can interfere with each other. If you must use a common FM/TV (or VCR) antenna, use a directional linkage type splitter.
- Follow the directions below to connect an antenna adapter to a 75 Ohm cable.
- Do not connect both the indoor T-shaped antenna and an outdoor FM antenna. If you decide to install an outdoor antenna, be sure to disconnect the indoor T-shaped antenna.

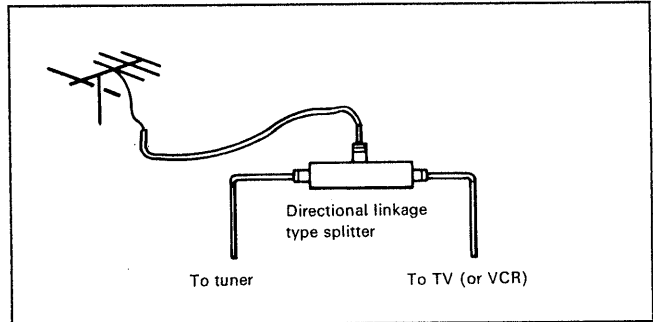

### AM loop antenna assembly

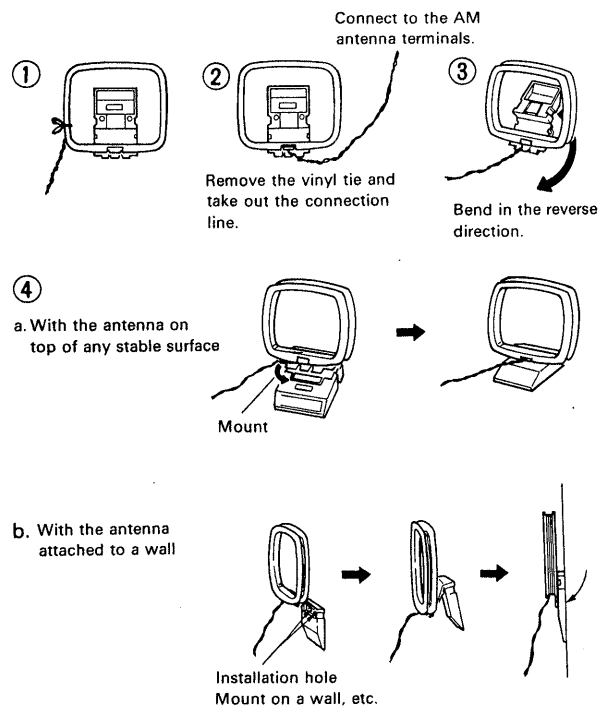

### AM Antenna Connections

An AM loop antenna is included in the installation instructions bag. Take out the connection line and connect it to the AM antenna terminals. This loop antenna can be used placed on top of the tuner or attached to a wall or other surface. Try several positions to determine which gives the best reception. Be sure the antenna is not near a speaker, power cord, television set, VCR, or motorized appliances. When using an external AM antenna, do not remove the loop antenna; connect both antennas to the AM antenna terminals.

**RI Remote Control jack ( RI : Remote Interactive)**

For remote control operation, connect this jack and any ONKYO amplifier bearing the " RI " mark using the remote control cable included with this unit. (Station Up/Down buttons can be controlled via remote control.) For more details, see the user's manual for the amplifier.

**NOTE:**

The **RI** mark is ONKYO's own mark. Audio equipment with this mark can be controlled through the amplifier with the **RI** mark, using remote control transmitter. Do not connect any product to this jack that does not have the ONKYO **RI** mark. Doing so can damage your equipment.

**Memory Preservation**

This unit does not require memory preservation batteries. A built-in memory power back-up system preserves the contents of the memory during power failures and even when the unit is unplugged. The unit must be plugged in and the power switch turned on and off once in order to charge the back-up system. Note that since this is not a permanent memory, the power switch must be turned on and off a few times each month to keep the back-up system operative.

The memory preservation period after power has been turned off varies depending on climate and placement of the unit. On the average, memory contents are protected over a period of a few weeks after the last time power has been turned off. This period is shorter when the unit is exposed to a highly humid climate.

**Front panel facilities**

**Front panel**

For more information about buttons or controls, turn to the page number listed in the [ ].

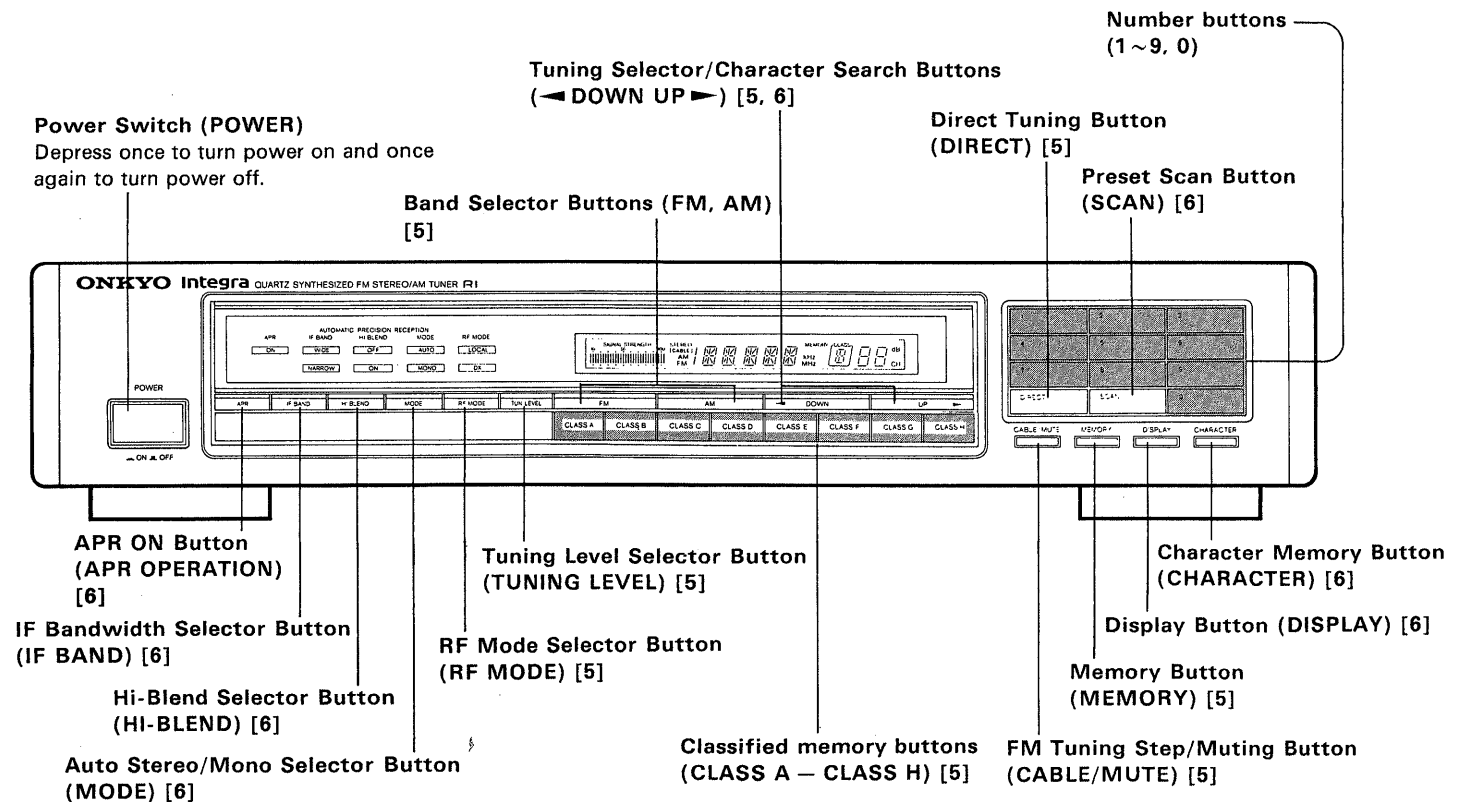

**Display and indicators**

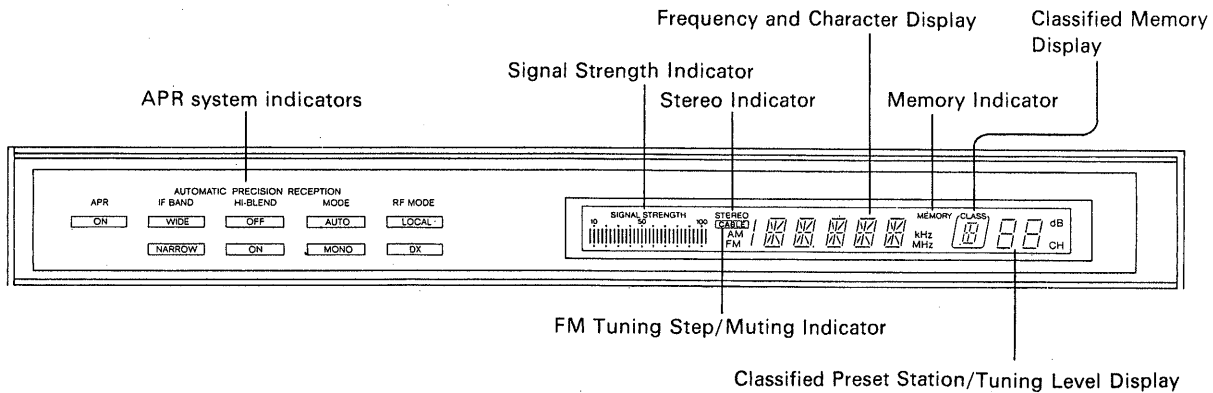

# Operations

- Before turning the power on, confirm that all connections have been made properly.
- All buttons on this unit (except the power switch) are soft-touch buttons. When the power is turned on, all settings return to the same ones set when power was last turned off.

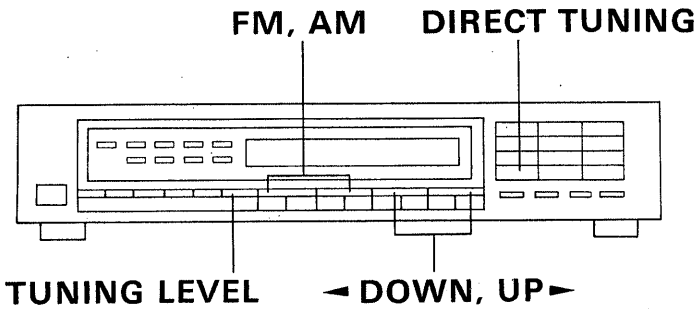

## ■ Tuning with the tuning buttons

To tune in an FM or AM station not stored in the memory, press the Tuning selector buttons. If you press UP, RF mode changes to DX and the frequency is increased. Pressing DOWN decreases the frequency. Note that the frequency is changed in 50kHz steps in FM and 9/10kHz steps in AM when the Tuning selector buttons is pressed in single steps. If this button is pressed continuously for more than 0.5 second, auto tuning mode is entered, and frequencies are scanned automatically. When a broadcast signal is received, scanning stops. If a different frequency is desired, press the button once again.

- Scanning will not stop for broadcasts weak enough to be suppressed by the muting circuit. To receive a weak FM broadcast, set the CABLE/MUTE button to the position the CABLE indicator is on, and select the frequency of the desired broadcast station in single steps.

## ■ Using the TUNING LEVEL button (FM only)

Each time this button is pressed, the auto tuning level is alternately set to 20 dB or 35 dB. Use the 35 dB setting if there are a lot of strong FM broadcasts in your area, and the 20 dB setting if there are a lot of weak FM broadcasts in your area. The current setting is shown in the multi function display for about two seconds each time this selector is pressed. To receive broadcasts below the level of 20 dB, set the CABLE/MUTE button to light up CABLE indicator and tune. The displayed tuning level unit of 'dB' is an abbreviation for dBf.

## ■ Signal Strength Indicator

Optimum tuning points are indicated by the number of lighted segments.

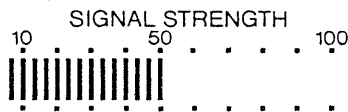

## ■ How to classify and memorize stations

The memory can be divided (classified) for different users or programs of stations.

With this model, eight classes (CLASS A to H) are available and stations can be memorized in any class. A total of 40 stations can be memorized in classes from A to H. Although the same station can be memorized in different classes, the memory number for the station will differ depending on the order in which the station is memorized in the classes.

- ① Tune in the desired station (see previous section on the tuning operations).

## ■ RF mode, DX or LOCAL (FM only)

DX mode should be used when receiving a weak signal from a far away station.

While LOCAL mode should be used when receiving a strong signal from a nearby station.

When tuning, using either the tuning buttons or the number buttons, with the APR button engaged, the RF mode will change automatically to DX mode.

If LOCAL mode is required, press the RF mode button to switch from DX mode.

## ■ FM Stereo Indicator

This indicator lights when an FM broadcast is being received. It does not light when a weak FM stereo broadcast is being received.

If you want to listen to an FM broadcast in MONO mode, press the MODE button to turn the Stereo Indicator off.

## ■ To achieve more precise tuning of a cable broadcasting station when receiving a cable FM (TV) broadcast

Use the UP or DOWN button to approximately locate the broadcasting frequency in 50 kHz steps, then use the CABLE/MUTE button to turn off FM muting and set the tuning step to 25 kHz. The [CABLE] indicator will light up so that manual tuning of the broadcasting frequency can be performed using the tuning selector button. During 25 kHz tuning step mode, automatic tuning is disabled. The conditions picked up during this Tuning Step Mode can be placed in memory.

### NOTE:

When the CABLE mode is cancelled, the tuning frequency returns to 50 kHz step mode.

Examples: 100.125 → 100.100 MHz  
 100.175 → 100.150  
 100.100 → 100.100

## ■ Receiving a station by inputting the frequency for the station directly (Direct Tuning)

If the frequency for the desired station is known, input the frequency number directly.

- ① Press the AM or FM button.
  - ② Press the DIRECT TUNING button.
    - "-" will flash for 16 seconds in the Frequency Display.
  - ③ Input the desired frequency number by using the Number Buttons while the cursors are flashing. For instance, if you wish to receive the station of 88.10MHz, press the Number Buttons, 8, 8, 1 and 0.
    - In areas where AM frequencies are set in 10kHz steps, inputting a number to the 10kHz digit sets 0 to the 1kHz digit automatically.
- If the desired frequency set in this operation does not exist, the frequency which is the nearest and lower than the desired frequency will be received. If the frequency set is not in the receive frequency range, the frequency flashes for two seconds and then the previous frequency will be displayed.
  - If a wrong frequency has been set, press the DIRECT TUNING button and start again.

- ② Press the MEMORY button.

- The MEMORY indicator will flash for 8 seconds.

- ③ Press the desired Classified Memory button (one of buttons A to H).

- The station is memorized in the selected class with the memory number which is the smallest of the unoccupied numbers in the class.

By repeating the operations above, up to 40 stations can be memorized. If an attempt is made to memorize 41 stations, "FULL" will be displayed in the Frequency Display, indicating that no more stations can be memorized.

**How to cancel memorized stations**

Retrieve the class number you want to cancel (see "How to retrieve memorized stations") and then press the DIRECT button while holding down the MEMORY button. Another station can be memorized with the memory number which has been cancelled.

**How to retrieve memorized stations**

- ① Press the Classified Memory button for the desired class.
  - The memory number (station) which was last used in the class will be received.
- ② There are several methods to proceed after the above operations are carried out. Use any of the following methods.
  - a. Pressing the same Classified Memory button again permits the next preset memory number (station) to be received.
  - b. Input the memory number you wish to receive by using the Number buttons.
    - If the memory number consists of 2 digits, input two numbers, immediately one after the other. For instance, when inputting "15", "15" will not be registered if you wait more than one second before inputting "5", resulting in only "1" being registered.
    - If a number other than a number from 1 to 40, or a number which has not been memorized is input, the number flashes for 2 seconds and then the number which was displayed before will be displayed.
    - If a number between 1 and 4 is pressed, the display and station are changed 1 second later.

c. Press the SCAN button

- Stations memorized in the present class will be scanned in a order and the corresponding memory number will flash in the Preset station display at each scan. After the last memory number of the class is reached, scanning starts again from the first memory number of the class. Pressing the SCAN button again stops scanning.
- Pressing the SCAN button after pressing the MEMORY button, enables you to scan through the memory numbers in all the classes one by one.

**APR (Automatic Precision Reception) System (FM only)**

This unit is equipped with ONKYO's unique APR system that automatically controls the Auto stereo/Mono reception modes, IF bandwidth wide/narrow setting and FM auto hi-blend circuit according to the quality (signal strength, distortion, etc.) of the signal currently being received. Consequently, optimum reception (the lowest distortion and highest S/N ratio) is assured at all times. Note that the APR system functions only during FM reception. An Auto Stereo/Mono Selector, IF bandwidth selector and auto hi-blend selector are provided to allow manually overriding these three APR controlled reception modes. If the station is retuned, or the APR button is pressed again however, the original APR selected modes will be restored. The APR system functions automatically when using the UP or DOWN buttons, or direct tuning. The APR settings are memorized when the station is memorized.

**How to name preset stations (Character memory function)**

This function enables you to memorize a maximum of 5 characters consisting of alphabetic, some symbols and numbers, for instance, representing broadcasting station names, for each preset station.

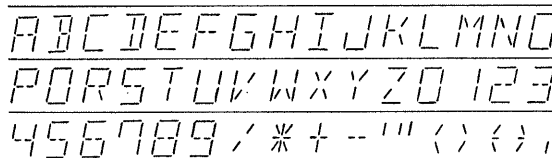
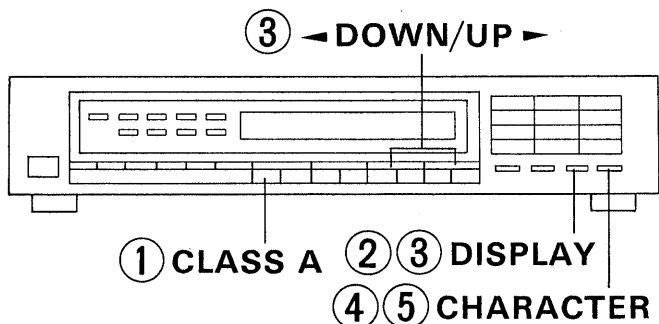

- ④ Press the CHARACTER button once more when the desired character is displayed. The character will be memorized and the cursor moves to the next character.



- Select 5 characters by repeating steps ③ and ④. If you want to include a space, press the CHARACTER button.
- ⑤ Press the CHARACTER button after selecting 5 characters.

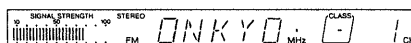

- Flashing stops, and the naming operation is complete.

The display shows an FM broadcast at 105.1 MHz has been memorized in 1 CH of the CLASS A, and has been named "ONKYO".

- ① Call up the station to be named, using the CLASS A Button.
  - If the broadcast has not yet been memorized in the preset station, see Page 5.

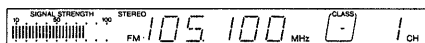

- ② Press the DISPLAY button.
  - The frequency in the display goes off and the cursor flashes at the first character.

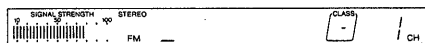

- ③ Select a character using the UP or DOWN button while the cursor is flashing (approx. 5 seconds).
  - The character changes from "A" to "B", "C" and so on when pressing the UP button, and changes in reverse order when pressing the DOWN button.



- Press the DISPLAY button once more if the cursor stops flashing.

**How to change the character**

Press the CHARACTER button to flash the character and select the desired character using the UP and DOWN buttons.

**How to delete all characters at once**

Press the DISPLAY button, while holding down the CHARACTER button.

**How to use the DISPLAY button**

When characters are memorized for a preset station, pressing the CLASS Button does not display the frequency, but the characters. Press the DISPLAY button if you want to display the frequency.

**NOTE:**

If you press DISPLAY once, and the wrong characters appear, press the button twice more: once to display the frequency, then once more to display the correct character sequence.

## Trouble-shooting guide

Trouble	Cause	Remedy
No power.	● Power cord is disconnected.	● Connect power cord.
Buzzing noise on AM, usually conspicuous at night or with a weak station.	● Noise from electrical apparatus such as fluorescent lamps.	● Move set to different location. ● Change the position or direction of the loop antenna.
High pitch noise.	● Noise from TV.	● Keep unit away from TV set.
Crackling noise on AM and FM.	● Noise caused by turning fluorescent lamp on and off. ● Noise from automobile ignition.	● Move the antenna as far away as possible from the fluorescent lamp. ● Install an outdoor FM antenna as far away as possible from the road.
AM stations cannot be received.	● AM loop antenna is not attached.	● Connect the included AM loop antenna to the AM antenna terminals.
FM signal strength indicators and stereo indicator light but sound is distorted and separation is bad.	● Station is too strong. ● Multiple reflection of the radio waves because of tall buildings or mountains.	● Change to T-shaped antenna. ● Use antenna which has better directivity and select a point where the distortion is least.
FM signal strength indicators and stereo indicator flicker and hiss is heard on FM.	● Station is too weak. ● Stereo FM broadcasts cover only about half the distance of an ordinary broadcast.	● Install an outdoor FM antenna. ● Change the position or direction of the outdoor antenna.
No station or undesired station is recalled when a Preset button is pressed.	● The Power switch has not been turned on for a long time, or the power cord has been unplugged for a long time.	● The memory contents are lost if the power is not turned on and off a few times each month. Store all stations in the memory again and remember to turn power on and off a few times each month.

The tuning steps by which the tuned frequency increases/decreases have been set at the factory to the proper value for the area where each unit is to be sold. If you use the unit in a country where a different tuning step is required or if the broadcast frequencies in your country change so that you can not tune in radio stations precisely, contact your ONKYO authorized service center.

## Specifications

### FM:

Tuning Range:	87.50 – 108.00 MHz (50/25 kHz steps)
Usable Sensitivity:	Mono: 10.8 dBf, 0.95 $\mu$ V, 75 Ohms IHF (75 Ohms IHF) Stereo: 17.2 dBf, 2.0 $\mu$ V, (75 Ohms IHF)
50dB Quieting Sensitivity:	Mono: 16.1 dBf, 1.7 $\mu$ V (75 Ohms) Stereo: 36.1 dBf, 17 $\mu$ V (75 Ohms)
Capture Ratio:	1.3 dB (Wide)
Image Rejection Ratio:	90 dB
IF Rejection Ratio:	90 dB
Signal-to-Noise Ratio:	Mono: 85 dB, IHF Stereo: 80 dB, IHF
Alternate Channel Attenuation:	50 dB IHF ( $\pm$ 400 kHz) (Narrow)
AM Suppression Ratio:	50 dB
Total Harmonic Distortion:	Mono: 0.1% (Wide) Stereo: 0.2% (Wide)
Frequency Response:	30 – 15,000 Hz +0.5 –1.0 dB
Stereo Separation:	45 dB at 1 kHz (Wide) 30 dB at 70 – 10,000Hz (Wide),
Output Voltage:	0.5 V
Muting Level:	17.2 dBf, 2.0 $\mu$ V (75 Ohms)

### AM:

Tuning Range:	530 – 1710 kHz (10 kHz steps)
Usable Sensitivity:	25 $\mu$ V
Image Rejection Ratio:	40 dB
IF Rejection Ratio:	40 dB
Signal-to-Noise Ratio:	40 dB
Total Harmonic Distortion:	0.7%
Output Voltage:	150 mV

### General

Power Supply:	AC120V, 60 Hz
Dimensions (W x H x D):	455 x 90 x 364 mm (17-15/16" x 3-5/8" x 14-5/16")
Weight:	4.8 kg 10.6 lbs.
Supplied accessories:	AM loop antenna x 1 FM T-shaped antenna x 1 Connecting cable x 1 RI remote control cable x 1 75/300 Ohm antenna adapter x 1

Specifications and features are subject to change without notice.

## ONKYO CORPORATION

International Division: Onarimon Yusen Bldg., 23-5, Nishi-Shimbashi 3-chome, Minato-ku, TOKYO 105, JAPAN Tel: 03-3432-6987 Fax: 03-3436-6979

### ONKYO U.S.A CORPORATION

200 Williams Drive, Ramsey, N.J. 07446, U.S.A.  
Tel: 201-825-7950 Fax: 201-825-8150