

PB84-910403

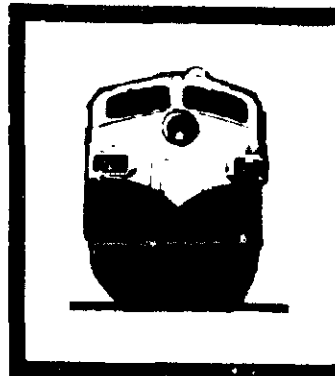

NATIONAL TRANSPORTATION SAFETY BOARD

WASHINGTON, D.C. 20594



AIRCRAFT ACCIDENT REPORT



**SIERRA PACIFIC AIRLINES
deHAVILLAND DHC-6-300, N361V
HAILEY, IDAHO
FEBRUARY 15, 1983**

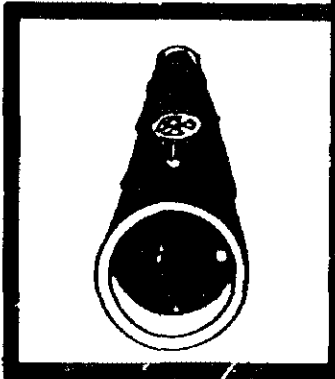

NTSB/AAR-84/03



UNITED STATES GOVERNMENT

REPRODUCED BY
NATIONAL TECHNICAL
INFORMATION SERVICE
US DEPARTMENT OF COMMERCE
SPRINGFIELD, VA 22161

TECHNICAL REPORT DOCUMENTATION PAGE

1. Report No. NTSB/AAR-84/03		2. Government Accession No. PB84-910403		3. Recipient's Catalog No.	
4. Title and Subtitle Aircraft Accident Report—Sierra Pacific Airlines, DHC-6-300, N361V, Hailey, Idaho, February 15, 1983				5. Report Date March 6, 1984	
				6. Performing Organization Code	
7. Author(s)				8. Performing Organization Report No.	
9. Performing Organization Name and Address National Transportation Safety Board Bureau of Accident Investigation Washington, D.C. 20594				10. Work Unit No. 3694A	
				11. Contract or Grant No.	
12. Sponsoring Agency Name and Address NATIONAL TRANSPORTATION SAFETY BOARD Washington, D. C. 20594				13. Type of Report and Period Covered Aircraft Accident Report February 15, 1983	
				14. Sponsoring Agency Code	
15. Supplementary Notes					
16. Abstract About 1100 m.s.t., on February 15, 1983, a Sierra Pacific Airlines DHC-6, operating as Transwestern Flight 868, a regularly scheduled commuter flight from Boise, Idaho, crashed during its final approach to a landing on runway 31, 1.7 miles south of the Friedman Memorial Airport at Hailey, Idaho. About 800 feet above the small town of Bellevue, 2 miles south of the airport, the captain reduced power for the final approach. The airplane nosed over and descended steeply. The captain attempted to control the pitch of the airplane by adding power; it began to recover but it crash-landed on a highway. The airplane then veered off the highway, struck a 4-foot-high snowbank, and broke apart. Two flightcrew members and six passengers were on board the flight. One passenger escaped with minor injuries, but all the other occupants were seriously injured. There was no fire. The National Transportation Safety Board determines that the probable cause of the accident was the inflight loss of elevator control following separation of the control rod from the torque tube at a connection where the company's maintenance department had used a nonstandard, unsecured bolt, which the company's inspection department had failed to detect. Contributing to the accident was the company's failure to maintain the separation of maintenance and inspection functions required by the maintenance program approved by the Federal Aviation Administration, and the failure of the FAA to detect the company's deviation from approved maintenance procedures during surveillance inspection.					
17. Key Words Final landing approach, disconnected elevator control linkage, loss of elevator control, hard landing, survivable accident, improper elevator control linkage installation, improper unsecured bolt, undetected by inspection unit, commingling of maintenance and inspection duties and responsibilities, inadequate FAA certification and surveillance				18. Distribution Statement This document is available to the public through the National Technical Information Service Springfield, Virginia 22161	
19. Security Classification (of this report) UNCLASSIFIED		20. Security Classification (of this page) UNCLASSIFIED		21. No. of Pages 52	22. Price

CONTENTS

	SYNOPSIS	1
1.	FACTUAL INFORMATION	1
1.1	History of the Flight	1
1.2	Injuries to Persons	3
1.3	Damage to Aircraft	3
1.4	Other Damage	3
1.5	Personnel Information	4
1.6	Aircraft Information	4
1.6.1	Weight and Balance Information.	5
1.7	Meteorological Information.	6
1.8	Aids to Navigation	6
1.9	Communications	6
1.10	Aerodrome Information	6
1.11	Flight Recorders	6
1.12	Wreckage and Impact Information	6
1.12.1	Flight Controls	8
1.13	Medical and Pathological Information	8
1.14	Fire	8
1.15	Survival Aspects	10
1.16	Tests and Research	11
1.16.1	Metallurgical Examination	11
1.16.2	Airplane Flight Characteristics	18
1.17	Additional Information.	18
1.17.1	Company Operations	18
1.17.2	Company Maintenance Program.	20
1.17.2.1	Personnel	20
1.17.2.2	Recordkeeping	21
1.17.2.3	Maintenance Personnel Statements	23
1.17.3	FAA Surveillance	24
1.18	New Investigative Techniques.	25
2.	ANALYSIS	26
	General	26
	Flightcrew Performance	26
	Disconnected Elevator Control Rod	26
	Company Maintenance and Inspection Program	28
	FAA Surveillance	29
	Survivability	29
3.	CONCLUSIONS.	30
3.1	Findings	30
3.2	Probable Cause	31
4.	RECOMMENDATIONS.	31
5.	APPENDIXES	33
	Appendix A-- investigation and Hearing.	33
	Appendix B--Personnel Information	34
	Appendix C--Aircraft Information	35
	Appendix D--Wreckage Distribution Chart	36
	Appendix E--Company Maintenance Program	37
	Appendix F--Airworthiness Directive	39
	Appendix G--Manufacturer Service Bulletin	40

**NATIONAL TRANSPORTATION SAFETY BOARD
WASHINGTON, D.C. 20594**

AVIATION ACCIDENT REPORT

Adopted: March 6, 1984

**SIERRA PACIFIC AIRLINES
deHAVILLAND DHC-6-300, N361V
HAILEY, IDAHO
FEBRUARY 15, 1983**

SYNOPSIS

About 1100 m.s.t., on February 15, 1983, a Sierra Pacific Airlines DHC-6, operating as Transwestern Flight 868, crashed during its final approach to a landing on runway 31, 1.7 miles south of the Friedman Memorial Airport at Hailey, Idaho. Flight 868 was a regularly scheduled commuter passenger flight between Boise and Hailey, Idaho. There were two flightcrew members and six passengers on board the flight. One passenger escaped with minor injuries, but all the other occupants sustained serious injuries in the accident. There was no fire.

About 800 feet above the small town of Bellevue, 2 miles south of the airport, the captain reduced power in order to configure the airplane for its final approach. Immediately afterward, the captain realized that he had lost elevator control of the airplane. The airplane nosed over and descended steeply. The captain attempted to control the pitch of the airplane by adding power; it began to recover but it crash landed on a highway in a slight nosedown attitude, with the right wing slightly down. The airplane then veered off the highway, struck a 4-foot-high snowbank, and broke apart.

The National Transportation Safety Board determines that the probable cause of the accident was the inflight loss of elevator control following separation of the control rod from the torque tube at a connection where the company's maintenance department had used a nonstandard, unsecured bolt, which the company's inspection department had failed to detect. Contributing to the accident was the company's failure to maintain the separation of maintenance and inspection functions required by the maintenance program approved by the Federal Aviation Administration, and the failure of the FAA to detect the company's deviation from approved maintenance procedures during surveillance inspection.

1. FACTUAL INFORMATION

1.1 History of the Flight

On the morning of February 15, 1983, the flightcrew of Transwestern Airlines Flight 868, a deHavilland DHC-6-300 (Twin Otter), N361V, prepared for its regularly scheduled passenger roundtrip flight to Hailey, Idaho, from Boise, Idaho. Although Transwestern had the route authority and marketed the route between Boise and Hailey, the operation of the flight was under the control and direction of Sierra Pacific Airlines. Under an agreement between Sierra Pacific and Transwestern, dated October 14, 1982, Sierra Pacific provided a DHC-6-300 Twin Otter with pilots, flight attendants, maintenance technicians, and flight-following to meet schedules provided by Transwestern.

Transwestern provided fuel, consumables, and ground handling. Sierra Pacific conducted the DHC-6 operation under 14 CFR Part 135. The air service between Boise and Halley was inaugurated on December 13, 1982.

The flightcrew members had flown N361V the day before and were not aware of any discrepancies in the airplane. On the morning of February 15 the airplane had been given routine field maintenance by a contractor, Western Aircraft Maintenance, Inc., of Boise, Idaho; and the crew did a routine preflight check. Six passengers were boarded--five adults and one child. The cargo consisted only of baggage, and nearly all of it was loaded in the nose cargo compartment of the airplane. According to the weight and balance release form, the takeoff gross weight was 11,084 pounds. Weather conditions along the route of flight were high scattered to broken clouds with visibility better than 20 miles. The company had a stored instrument flight rules (IFR) flight plan for the route on file with the Salt Lake City Air Route Traffic Control Center (ARTCC), and the captain obtained his flight release from the company by telephone from its headquarters in Tucson, Arizona. Since the terminal and en-route weather indicated that the flight could be conducted under visual flight rules (VFR), the flightcrew cancelled the stored IFR plan at 1014:42. 1/ This was contrary to company procedure, which required that a flight plan be filed for all flights.

Flight 868 obtained taxi clearance to runway 10L at 1019:06 and takeoff clearance at 1019:56. At 1021:47 Boise departure control established radar contact with the flight and, 3.5 minutes later, informed the flightcrew that it was leaving the terminal radar service area. At 1031:18 radar service ended when the flight was about 22 miles east-northeast of Boise. The flight proceeded to Halley at an en-route altitude of 9,500 feet 2/ and at 120 knots indicated air speed (KIAS). The air was smooth and the flight was uneventful until about 40 minutes later, when the airplane reached the small town of Bellevue, about 2 miles south of the Friedman Memorial Airport.

In accordance with the local airport arrival procedure, the captain began a descent by reducing power about 15 miles from Bellevue. The descent was made at 500 feet per minute at 140 to 150 KIAS in order to cross Bellevue at 6,000 feet, or about 700 feet above ground level (a.g.l.). On reaching Bellevue, customary local pilot technique called for further reduction of power to 10 pounds per square inch (p.s.i.) of torque pressure 3/ and application of noseup elevator trim to slow the airplane to the flap extension speed of 100 KIAS.

At 100 KIAS the captain normally lowered the flaps to 10°. This technique generally established the airplane on a normal descent to runway 31, consistent with the visual approach slope indicator for the runway. However, when the captain of Flight 868 reduced power to 10 p.s.i. of torque pressure, he could not control the corresponding change in nosedown pitch using the elevator. The captain felt no binding in the control system with full forward and aft movement of the control column. He told the first officer, "We have a problem." The first officer instructed the passengers over the public address system to make sure that their seatbelts were fastened and radioed the airport to "clear the area for an emergency."

1/ All times in this report are mountain standard time based on the 24-hour clock.

2/ All altitudes herein are above mean sea level, unless otherwise indicated.

3/ The torque being developed by the engine is presented on a cockpit instrument in terms of a pressure proportional to the torque.

The captain recalled that the airplane pitched nearly straight down almost immediately after he had reduced power at Bellevue. He attempted to level the airplane by applying full power to both engines and did not remember reducing it at anytime thereafter. He could not recall if he had used elevator trim to level the airplane at anytime. Realizing that he could not make a landing at the airport, the captain attempted a landing on U.S. Highway 75, directly below his route of flight. The airplane had just begun to recover from the dive when it struck the highway. The captain could not remember, but the first officer believed that the airplane was traveling about 120 KIAS on impact, with a 30° to 35° nosedown attitude. The flightcrew members estimated that it was about 30 seconds from the time they first recognized the problem until impact on the highway. They could not recall any events following the impact.

The passenger in seat 3C sat up in his seat when the airplane was "very low" (about 100 feet above the ground), and he saw the highway and vehicles coming toward the airplane through the cockpit windshield. The passenger in seat 6C saw the pilot "frantically turning something above the windshield." The passenger in seat 2C saw that the pilot was "madly going up and down with a big lever overhead." The passenger in 4C said the pilots "looked excited" and both were reaching upward. (See figure 1 for seating arrangement in N351V.)

Motorists traveling north and south on Highway 75 who witnessed the accident indicated that the airplane's nose gear and right main landing gear were the first to strike the highway. The airplane then veered off to the right side of the highway, struck a snow bank, cartwheeled, and broke apart; there was no fire. As a result of the crash, the crew and five passengers were seriously injured, and a 12-year-old boy escaped with minor injuries.

Operators at the airport, local authorities, and other persons in the area did not receive reports of a signal from an emergency locator transmitter (ELT).

The accident occurred about 1100, 1.7 miles south of the airport on U.S. Highway 75. The coordinates of the accident site are latitude 43°30'N, longitude 114°18'W.

1.2 Injuries to Persons

<u>Injuries</u>	<u>Crew</u>	<u>Passengers</u>	<u>Others</u>	<u>Total</u>
Fatal	0	0	0	0
Serious	2	5	0	7
Minor/None	0	1	0	1
Total	2	6	0	8

1.3 Damage to Aircraft

The aircraft was destroyed.

1.4 Other Damage

None

19 PASSENGER SEATS

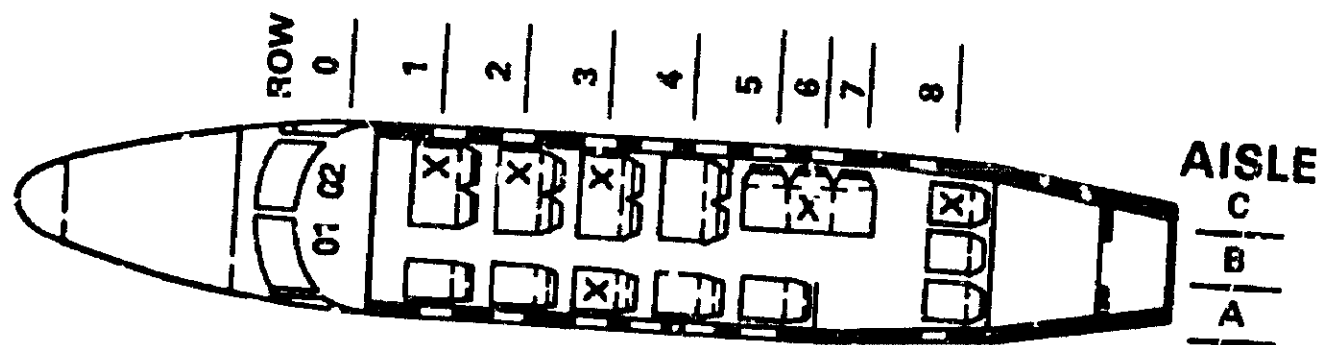

Figure 1.—Occupant seating arrangement in N361V. The "X's" represent the passengers' seated positions in the airplane.

1.5 Personnel Information

The captain was qualified and certificated for the flight. He had accumulated a total of about 12,000 flight-hours at the time of the accident, of which about 1,000 hours were acquired as pilot-in-command in the DHC-6. He had been on duty for 7 hours within the 24-hour period before the accident. (See appendix B.)

The first officer was qualified and certificated for the flight. He had flown a total of 275 flight-hours, of which about 100 hours were flown in the DHC-6. He had also been on duty for 7 hours within the 24-hour period before the accident. (See appendix B.)

1.6 Aircraft Information

N361V was owned and operated by Sierra Pacific Airlines. The airplane was type certificated in accordance with Civil Air Regulations (CAR) 3, dated May 15, 1956. The airplane received a standard airworthiness certificate in the normal category on May 16, 1973. It had accrued a total time of 4,795 hours at the time of the accident. (See appendix C.)

In May 1973, the airplane was purchased and was operated by Intermountain Air Service, Inc., a predecessor to Sierra Pacific Airlines, Inc. The airplane was registered to Sierra Pacific in 1979.

On December 15, 1980, Sierra Pacific had checked for possible loss of flight control from stress corrosion cracking of the control rods for elevator, flap, and ailerons, as directed by Airworthiness Directive (AD) 80-13-11, issued July 1, 1980. The action, taken December 15, 1980, at 4,344 hours airframe time, was in accordance with

deHavilland Service Bulletin (SB) 390. The last 500-hour (main base) inspection was performed on May 28, 1981, within an approved inspection interval, at the company's maintenance facility at Marana Air Park, Marana, Arizona, at a total airframe time of 4,373 hours. On December 2, 1981, the flight control rods were due for reinspection. The airplane was flown 7 hours on December 8, 1981, bringing its total airframe time to 4,384 hours. The reinspection of the rods was not completed until February 11, 1982, because the airplane was partially disassembled and repainted during the period December 16, 1981, to February 3, 1982, by Evergreen Air Center at Marana Air Park. The Transwestern logo was painted on the airplane at that time. The flight control surfaces were rebalanced on January 28, 1982, after the painting. According to the work orders, Sierra Pacific was responsible for removing and reinstalling the flight control surfaces. On March 12, 1982, the reinstallation of the flight control surfaces was checked in a test flight. The controls were determined to have functioned normally during the 6-minute test flight. The total airframe time remained at 4,594 hours after the flight. The airplane was not flown again until about December 13, 1982, but normal reinspection of the flight control rods was performed by the company on November 5, 1982. No defects were reported.

On about December 13, 1982, the airplane was flown to Boise, Idaho, to operate on Transwestern's routes from Boise. Western Aircraft Maintenance, Inc., performed some unscheduled maintenance on the airplane on that date; also, on December 20 and 21, 1982, it installed a Field Aviation, Inc., baggage pod on the underside of the fuselage to accommodate snow ski equipment. Following the installation, the airplane's empty weight and balance was recalculated. The new empty weight averaged 7,623 pounds and its center of gravity (c.g.) was 210.3 inches. These were last recorded on December 23, 1982. In addition to some unscheduled maintenance, Western Aircraft also performed two field base inspections (100-hour intervals). The first was completed on January 4, 1983, at an airframe time of 4,675 hours, and the last was conducted on February 5, 1983, at an airframe time of 4,767 hours. In the last maintenance, performed by Western Aircraft on February 10, 1983, the left landing light bulb was replaced and the oil in the right engine was checked.

All pertinent AD's had been satisfied before the accident. The airplane had no known outstanding discrepancies before the accident flight.

1.6.1 Weight and Balance Information

The maximum certificated takeoff and landing gross weights for the DHC-6-300 are 12,500 and 12,300 pounds, respectively. Several irregularities were noted on the weight and balance release form signed by the captain for Flight 868. The total takeoff gross weight was 10,884 pounds, although the crew incorrectly reported it as 11,084 pounds due to an error in calculations. The Safety Board could not determine the c.g. based on the information on the form. All of the baggage was loaded in the nose compartment of the airplane, contrary to company loading procedures, which required that the first 300 pounds of cargo be loaded in the aft compartment. The release form also indicated that an average baggage weight of 24 pounds was used to calculate the takeoff weight. The company's FAA Operations Specifications do not permit the use of average baggage weight on DHC-6 flights. Additionally, the release form showed that the total passenger weight included six adults instead of five adults and one 12-year-old boy.

Using the actual passenger weights and 190 pounds for each flightcrew member, the takeoff weight and balance was computed to have been 10,637 pounds at a c.g. of 19.4 percent mean aerodynamic chord (MAC). This was 0.7 percent forward of the

forward allowable limit for the takeoff weight. The landing grossing weight was 10,237 pounds at a c.g. of 19.6 percent MAC. This also was 0.7 percent forward of the forward allowable c.g. limit for the landing weight.

1.7 Meteorological Information

The surface weather observations at the locations and times indicated are as follows:

0950 - Boise Special: scattered--10,000 feet; estimated broken--12,000 feet; overcast--20,000 feet; visibility--30 miles.

1106 - Hailey Special: scattered--20,000 feet; visibility--20 miles; temperature--28° F; wind--350° at 5 knots; altimeter--30.20 inHg.

1.8 Aids to Navigation

Not applicable.

1.9 Communications

There were no known problems with communications.

1.10 Aerodrome Information

Friedman Memorial Airport, located at an elevation of 5,315 feet, is an uncontrolled airport which makes use of Unicom to broadcast traffic advisories on 122.8 MHz. The airport serves commuters, charters, and air taxis certified by the Civil Aeronautics Board as well as general aviation traffic. As an Index A airport, it is certified for firefighting and rescue capabilities for aircraft not longer than 90 feet. The city of Hailey Volunteer Fire Department provides the airport with firefighting and rescue services. The fire department is located two blocks from the main entrance to the airport.

1.11 Flight Recorders

No flight recorders were installed in the airplane, nor were any required by regulation.

1.12 Wreckage and Impact Information

U.S. Highway 75 is straight and level in the area of the accident site and is oriented on a magnetic heading of 307°; the highway is 24 feet wide. Three- to 4-foot-high snowbanks lined each side of the highway and were about 46 feet apart along the shoulders of the highway. A sparsely spaced line of telephone poles ran parallel to the highway 20 to 30 feet from the left shoulder. A pole, located 270 feet back along the airplane's projected flightpath in line with the point of initial impact, was undamaged. The angle between the top of the pole and the point of initial impact was 5°. Skid marks from all three landing gear tires marked the airplane's point of initial impact with the highway. The tire marks were initially oriented on a magnetic heading of 310° and were continuous for about 260 feet before they turned to the right and went off the pavement. The first tire skid mark on the pavement was made by the right main landing-gear tire, followed by the nosegear tire mark 10 feet beyond and the left main landing-gear tire

mark 4 feet beyond the nosegear mark. Marks from the left main-gear and the nosegear tires were on the left side of the highway centerline. The right tire mark was 400 feet long. The nosegear track merged into the right track at the 345-foot point. The left track was 272 feet long and ended where the nosegear track began to converge toward the right track. (See appendix D.)

At 130 feet beyond the initial touchdown point, pieces of the right wingtip and chips of paint were found embedded in the snowbank on the right side of the highway. There was a large impact gouge in the snowbank where the landing gear tire tracks ended. Beyond the impact gouge wreckage was strewn for about 360 feet on a path across the snow 10 to 30 feet from the edge of the snowbank. The major separated sections of wreckage were the empennage, the baggage pod, the left engine, the right wing with the engine attached, the fuselage, and the left wing. A crater in the snow, measuring 6 feet in diameter and 2 feet deep, was located between the baggage pod and the left engine.

The cockpit area of the fuselage was demolished. Except for some localized damage, the remainder of the fuselage maintained its shape from fuselage station (FS) 109 to FS 406. The empennage had separated from the fuselage in the area of the tailcone near FS 440. Both wings separated from the fuselage at the front and rear wing-spar attachments. The fuselage area underneath the wings was ripped open along rivet lines; the flap actuator, the actuator links, the flap push-pull rod, and the supporting channel structure were exposed. A break in the fuselage directly above the main landing gear (FS 240) extended across the top and down both sides to the level of the cabin windows. The fuselage was punctured on the right side (FS 144) in front of the wing and below the emergency window exit, which coincided with the shape of the broken end of the right wing. There was a dent on the left side below the cabin airstair door.

The nosegear separated from the fuselage at the upper and lower attachments. The left main landing gear remained attached to the fuselage and was relatively intact. The right main landing gear remained attached, but the urethane compression blocks were dislodged and the preload bolt that held them in place was broken. According to the manufacturer, properly installed compression blocks do not burst out unless the design landing loads are exceeded.

The left engine and nacelle separated from the wing at the firewall. The propeller remained attached and was relatively intact. Control system linkages appeared intact and functional. The turbine section showed evidence of rotational damage. The propeller of the right engine remained attached. The blades tips were curled and abraded. About 3 inches of one blade tip had separated and lodged itself into the left inside wall of the cabin. The right engine exhaust case exhibited torsional damage.

The ELT was installed on the left side of the fuselage just behind the cargo compartment bulkhead at FS 376. It was found intact in its mounting bracket. The external antenna was also intact and securely fastened to the outside of the fuselage above the ELT unit. However, the antenna lead-in wire was broken. The self-contained antenna on the ELT was in the normal, retracted position. Snow was packed around the unit and on the ON-OFF-ARM switch. Removal of the snow disclosed that the switch was in the OFF position. The ELT battery expiration date was January 28, 1984. The ELT operated when tested. There was no remote ON-OFF-ARM switch for the unit located in the cockpit.

1.12.1 Flight Controls

Examination of the aileron and wing flap control systems gave no evidence of a preimpact failure or malfunction. The flap actuator was in the fully retracted position. Holes punctured in the fuselage skin corresponded to the inboard flap hinge bolts and confirmed that the flaps were retracted. The flap and elevator interconnect cables had broken in the area where the empennage had separated. The ballscrew jack was attached to the flap bellcrank, but the end of the ballscrew jack was pulled free from a fuselage attachment. Control cables remained attached to the ballscrew jack, which rotated freely. The associated trim tab jackscrew remained intact on the elevator.

Examination of the rudder control system disclosed that the control cable and the control quadrant for the torque tube were broken. However, there was no evidence to indicate that the separations resulted from a preimpact failure.

Examination of the elevator and rudder trim tab systems showed that the cables had separated near the area where the empennage separated from the fuselage. There was no evidence of a preimpact failure or malfunction of these control systems.

The elevator control cable was broken in two places -- under the floor in the cockpit and in the tailcone area, where the empennage had separated from the fuselage. The control column was broken from the attachment slot for the left bearing, and the push-pull connecting rod was fractured where it was attached to the base of the control column. The control cable remained attached normally to the elevator control lever below the control column. The elevator stop cable was broken, but the ends remained attached normally to the fore and aft pulley assemblies. The examination of the elevator control system in the fuselage, including all of the pulleys, disclosed no evidence of a preimpact failure or malfunction.

The remaining elevator control cables in the empennage were attached properly to the control quadrant. The control rod (Part No. C6CF 1141-1) that connected the elevator control quadrant to the elevator torque tube was attached properly to the quadrant, but it was not attached to the torque tube. (See figures 2 and 3.) The standard parts used to connect the rod to the torque tube were not found. A bolt, similar in size to the rod's lower attachment bolt, and several washers were found loose within the vertical stabilizer. The connecting rod was bent slightly, with two dents in the front surface of the rod. The dents were located 3.5 and 6 inches from the lower connecting rod-end bearing. The dents corresponded to the location of a stabilizer stiffener and web when the elevator control quadrant was placed in the full nosedown position.

1.13 Medical and Pathological Information

Seven of the occupants were treated for serious injuries. Six were taken to the Blaine County Hospital in Hailey for treatment. The captain and the seriously injured passenger in seat 6C were taken by helicopter to the Saint Alphonsus Hospital in Boise.

1.14 Fire

There was no fire.

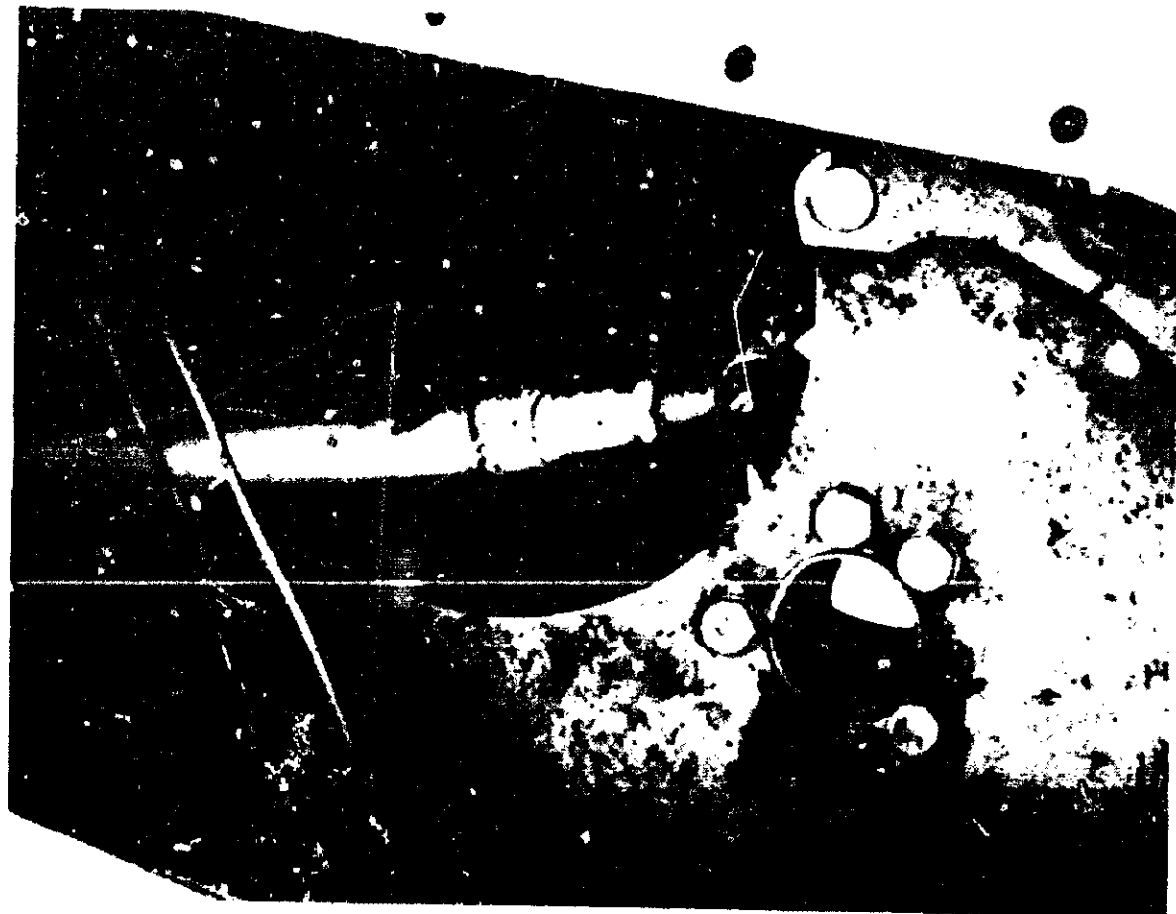

Figure 2.—Lower end of the elevator connecting rod attached to elevator control quadrant.



Figure 3.—Clevis ears of elevator torque tube and upper end of connecting rod, as found at the accident site, still in place in the empennage.

1.15 Survival Aspects

One of the motorists informed a service station attendant in Bellevue of the accident, and the attendant in turn called the Blaine County Sheriff's Department at 1102. The Sheriff's Department, located in Bellevue, responded immediately and notified area ambulance services as well as the Hailey Fire Department, which provided three fire trucks. Sheriff's deputies were on the scene within 6 minutes of being called.

The events just before impact with the highway, during evacuation from the airplane, and during rescue efforts was assembled from interviews with the flightcrew, passengers, and rescue personnel.

All of the occupants heard the fasten-seatbelt announcement and had their seatbelts securely fastened. The passenger in seat 8C estimated that the airplane struck the highway 20 to 30 seconds after the announcement. The passengers described the impact as a "loud bang" and a "big bump" and said that everything went "around and around" and "topsy-turvy." The passenger in seat 8C saw the passenger in 3C "bouncing around like a rag doll."

The captain was thrown ahead of the airplane while still strapped to the remains of his seat by his seatbelt. His shoulder harness failed. The first officer's shoulder harness also failed; he came to rest strapped to his seat and buried under snow in the cockpit area. The passenger in seat 3C remained strapped to his seat, but the seat broke loose and came to rest on top of the passenger entry door at the rear. The seatback of seat 4C broke but the seat remained attached to the floor and the seatbelt remained secured. The seats and seatbelts of the other passengers were undamaged and remained secured, leaving the passengers in 2C, 4C, 6C, and 8C "dangling" from the seats which remained in place. (See figure 4 for injury chart.)

<u>Publ AIS^a</u> <u>Severity</u>	<u>Seat</u>	<u>Sex</u>	<u>Age</u>	<u>Abdomen</u> <u>Thorax</u>	<u>Spine</u>	<u>Lower</u> <u>Extrem</u>	<u>Probable</u> <u>Internal</u>	<u>Head</u> <u>Face</u>	<u>Multiple</u> <u>Trauma</u>
4	01	M	30	X				X	
3	02	M	35	X			X		X
3	2C	F	42	X		X			
3	3C	M	30	X	X				
	4A	M	12			X			
3	4C	F	36	X			X		
4	6C	F	38		X				
3	8C	F	35		X	X			
TOTALS				5	3	3	2	1	1

^a "Abbreviated Injury Scale" of Severity by American Medical Association.

Figure 4.--Injury chart.

The passenger in seat 3C was the first to exit the airplane. He was aware of the right-side fuselage exits, which were then overhead, but also noted a clear exit route through the opening in the cockpit. The passengers in seats 4A, 6C, and 8C also escaped through the opening in the cockpit. Motorists assisted them from the airplane.

The passenger in seat 8C was the second one to escape. She had unfastened her seatbelt and fell. She was shaken and disoriented, but smelled fuel and realized that she had to move. She saw the passenger from seat 3C exit the airplane and she crawled after him. As she did so she saw the young boy (4A) unbuckle the seatbelt of the passenger in seat 2C. A motorist assisted her outside of the airplane and she told him there were others inside and to call ambulances and fire trucks. The young boy was the third to exit the fuselage. Although he was concerned about his mother's injuries (passenger in 4C), he followed her instructions and departed through the opening in the cockpit. The fourth to exit the airplane was the passenger in seat 6C. She was the passenger most seriously injured. She had released her seatbelt and observed the young boy exiting the airplane and followed him. The fear of fire kept her going until she crawled 15 to 20 feet away from the fuselage. She and the captain were transported by helicopter to Saint Alphonsus Hospital in Boise. The passengers in seats 2C and 4C were the fifth and sixth passengers, respectively, to exit the airplane. They were assisted out of the wreckage by ambulance service personnel.

All of the cabin exits were found to be operable when the fuselage was placed upright during the wreckage examination.

1.16 Tests and Research

1.16.1 Metallurgical Examination

Portions of the elevator control system, consisting of the torque tube, connecting rod, and a bolt, were examined in the Safety Board's metallurgical laboratory. The rod contained the required reinforcing sleeves; however, it did not contain the required stamp showing that it had been inspected. The connecting rod is normally installed in the elevator torque tube by placing the spherical bearing end of the rod between the clevis ears of the torque tube and attaching them with a standard AN 174-12 bolt, an AN 960 D416 washer, and an MS 17826-4 castellated nut secured by an MS 24665-159 cotter pin. (See figure 5.) This task is performed from the right side of the airplane empennage and requires removal of a fairing before the work can be accomplished. There is no access plate on the left side of the empennage for this purpose. Schematic drawings of the installation show the bolt head facing the left side of the airplane. In this position the threaded end of the bolt is readily visible from the right side of the empennage, and it is relatively easy to attach the nut and cotter pin from the right side. If the bolt is reversed, the nut and cotter pin cannot be seen without the aid of an inspection mirror. (See figures 6 and 7.) In the following discussion of the position of the parts in the empennage, the terms "right" and "left" are defined relative to the normal forward seated position in the airplane.

Torque Tube Clevis.--The clevis ears of the torque tube exhibited considerable mechanical damage on their inner surfaces. (See figure 8.) The inside surfaces of the clevis ear attachment holes showed damage consistent with contact with the sides of the spherical bearing of the connecting rod, as shown by arrows "r" in figure 8. However, white paint on the surface of the clevis ears between the holes and the outer edges of the rod-end bearing damage indicated that the bearing damage had occurred before the last painting of the part.

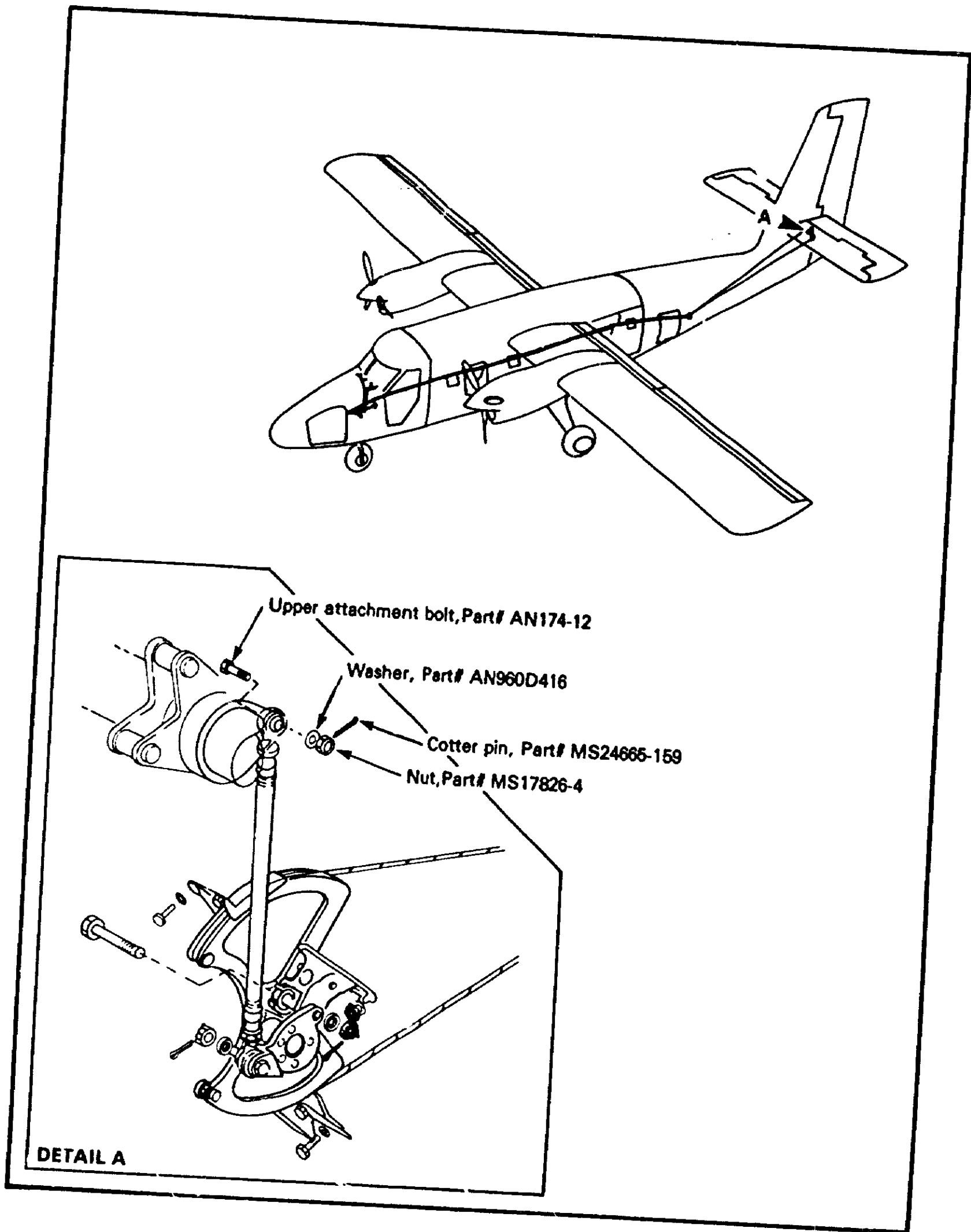

Figure 5.—Elevator control installation, from deHavilland DHC-6-300 IPC, Chapter 27-30-00, page 0, figure 1 (descriptions added to the illustration for clarity).



Figure 6.--View of the elevator control rod connected to the torque tube clevis, with fairing installed.



Figure 7.—View of the elevator control rod connected to the torque tube clevis, with the fairing removed.



Figure 8.--Views of the mechanical damage to the inner surfaces of the clevis ears from the elevator torque tube. Arrows "E1" and "E2" refer to the left and right clevis ears, respectively.

Figure 9 shows closeup views of the outer surfaces of the clevis ears. The left photograph in figure 9 shows no scratch marks on the painted outboard surface of the left clevis ear from the presence of a nut, washer, or bolt head. (Missing paint above the bolt hole indicated that the elevator had been suspended when it was painted.) The outboard surface of the right clevis ear, shown in the right photograph in figure 9, had marks in and on the painted surface, indicating that a washer, nut, or bolt head had contacted this surface.

Bench microscopic examination of the bolt hole walls in the clevis ears (figure 10) showed that the left clevis ear had been marked more heavily from the threads of a bolt than had the right clevis ear.

Bolt Found in Empennage.--Figure 11 shows two views of the bolt found loose in the empennage area. The bottom view shows the bolt rotated about 45° relative to the top view. The overall length of the bolt from the underside of the head measured 1.16 inches, and the diameter of the shank was 0.245 inch. An AN 174-12 bolt is 0.2487 to 0.2492 inches in diameter by about 1.27 to 1.31 inches in length. Arrow "M" in figure 11 shows an area of the bolt with metal apparently smeared onto the bolt. Figure 12 shows this area in greater detail.

The metal smear was dislodged with ultrasonic cleaning in acetone and was identified with x-ray energy dispersive analysis (XEDA). Figure 13 shows the smeared metal flake removed from the bolt. The metal fragment was placed on a carbon stage along with a small section excised from the torque tube arm for comparison.

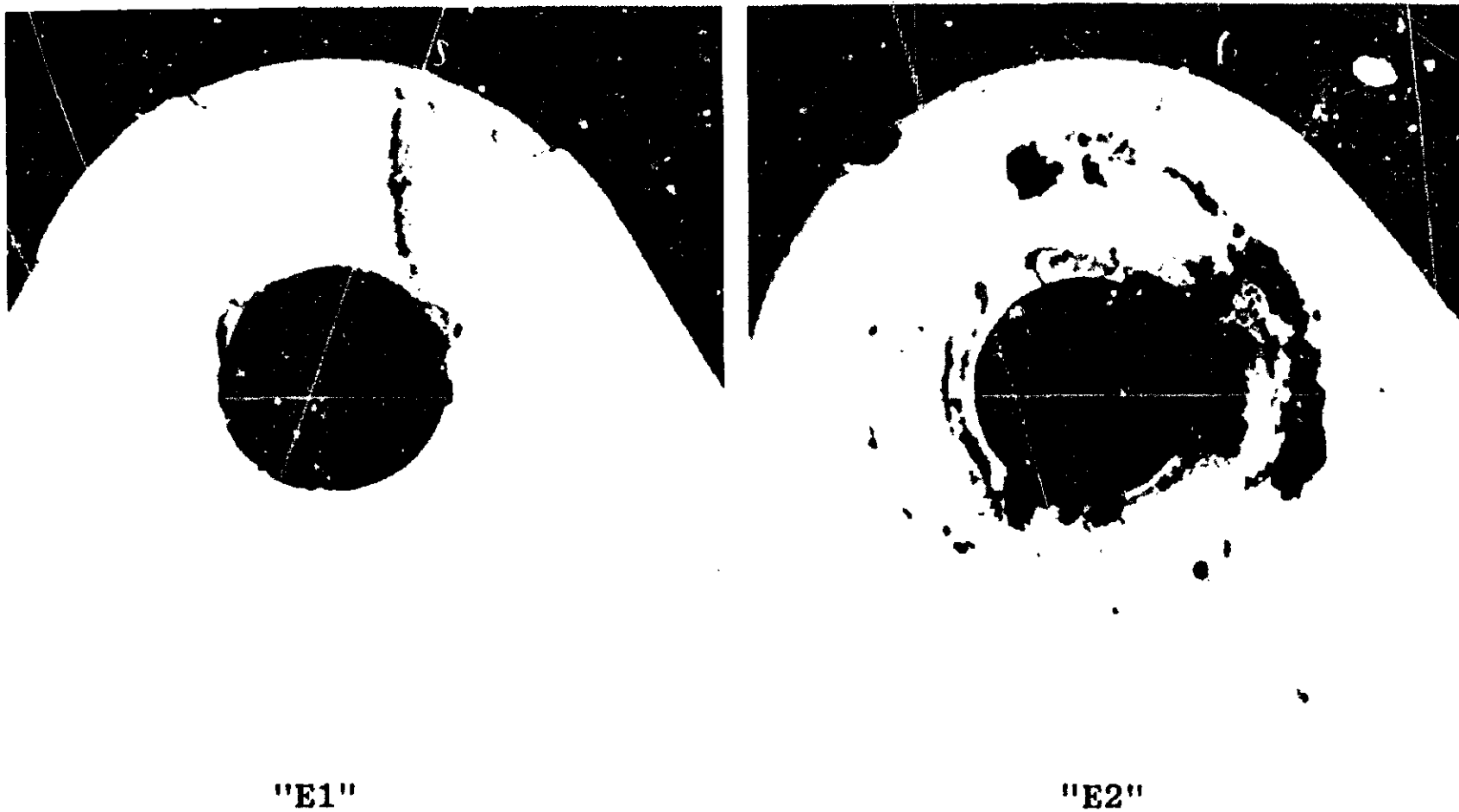

Figure 9.--Left photograph ("E1") shows the outboard surface of the left ear (side not visible on inspection), and the right photograph ("E2") displays the outboard surface of the right ear (visible side). Both photographs X4.

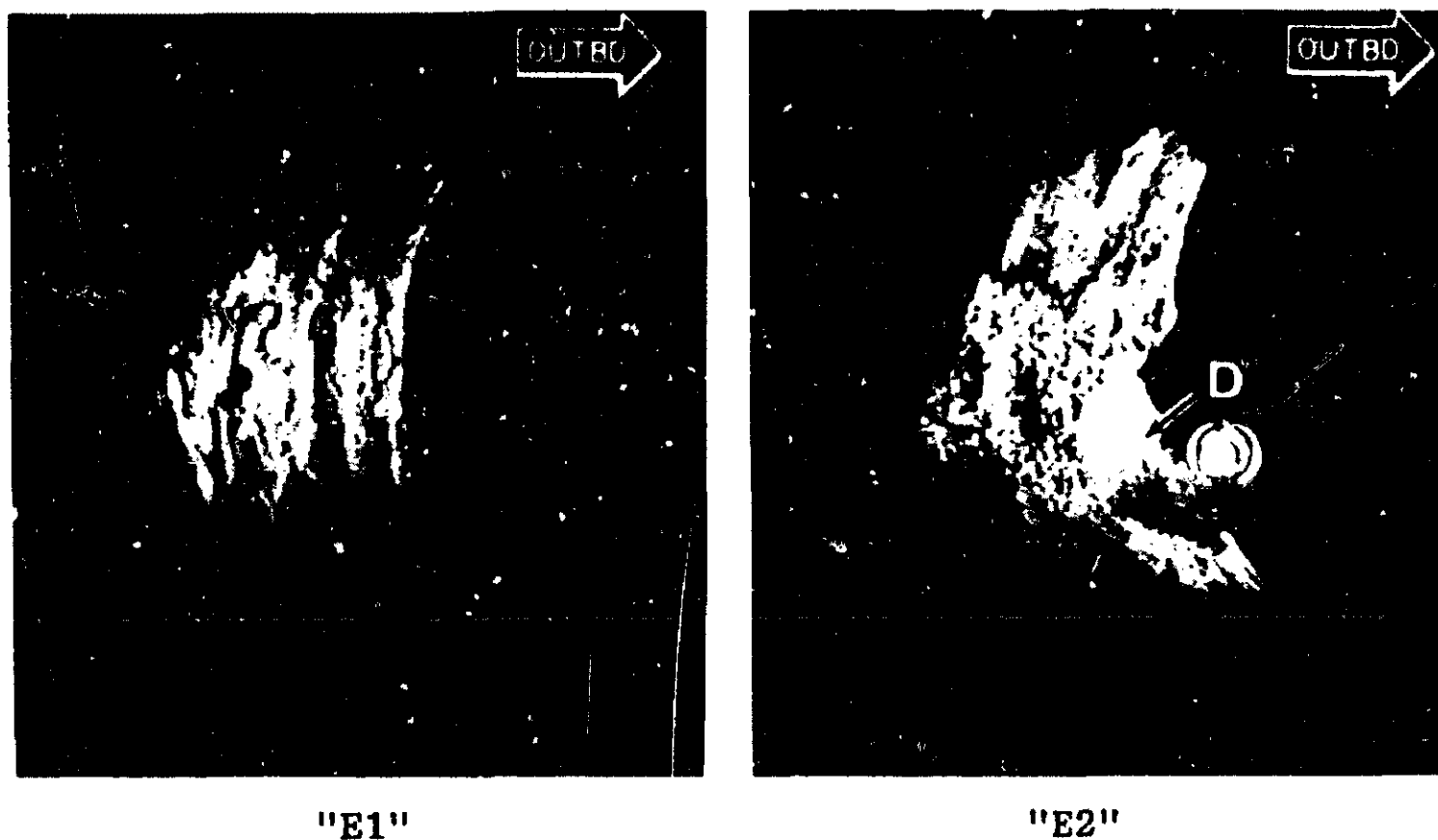

Figure 10.--Detailed views of the surfaces of the holes in the clevis ears, used to attached the elevator torque tubes. "Outboard" arrow refers to the right side of the airplane. "E1," from the left clevis ear, shows extensive damage. "E2," from the right clevis ear, shows a smooth surface, except for an area of localized damage marked by the arrow "D." Both photographs about X5.

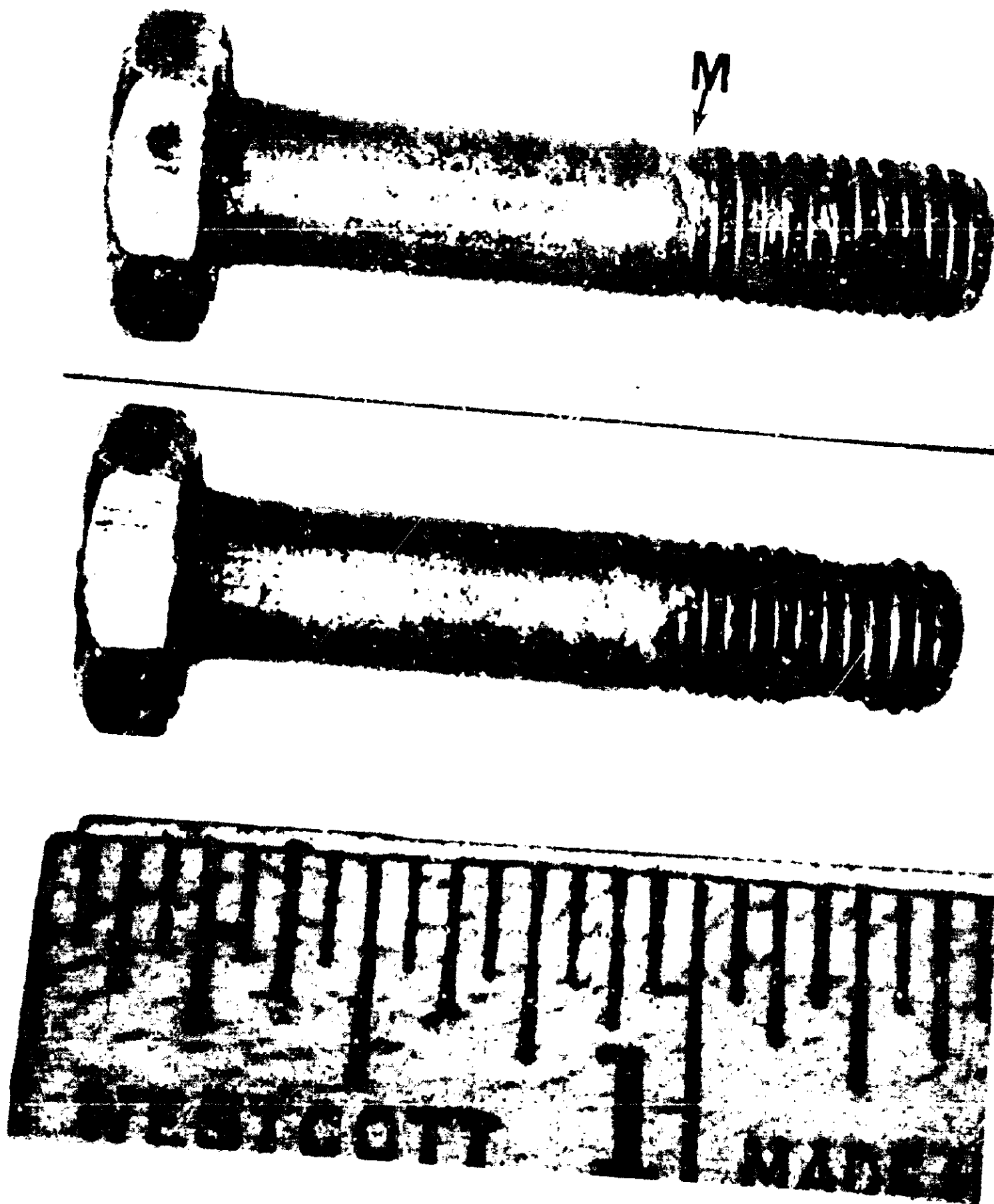

Figure 11.--Two views of the bolt that was found in the empennage.
"M" indicates a metal smear.



Figure 12.--Scanning electron micrograph of the bolt showing the area of smeared metal (arrows M in figure 11). About X10.



Figure 13.--Scanning electron micrograph of the smeared metal piece (shown by arrow "M" in figure 12) after it was removed from the bolt. View shows inside radius of smeared contour. About X10.

X-ray spectra generated for both specimens under identical electron beam conditions and time showed that the metal flake was composed of the same material as the torque tube (required material for torque tube 6061-T4 aluminum alloy). In addition to energy peaks from the elements of the torque tube material, the spectra generated from the metal fragment contained smaller energy peaks for cadmium, titanium, chromium, and iron, which are representative of a cadmium-plated steel bolt material. The threaded end of the bolt contained notable wear on the last few thread crowns, as shown by bracket "W" in figure 14. Also, each of the thread roots was filled with debris that XEDA analysis showed to be rich in aluminum and silicon.

Spherical Bearing Attachment Hole.--The right photograph of figure 14 is a closeup view of the hole wall in the spherical bearing of the connecting rod. The left side of the hole wall displayed smeared metal flakes, and the remainder was relatively smooth.

An XEDA spectrum produced from one of the metal flakes removed from the spherical bearing hole wall gave spectra for the presence of aluminum, silicon, cadmium, titanium, chromium, and iron. The relatively strong peak of aluminum generated in this analysis probably represents an aluminum alloy. The remaining peaks, however, represent the surface finish on the bolt (cadmium and possibly chromium), the paint used in the assembly (silicon, titanium), and the bolt material (iron and possibly chromium).

1.16.2 Airplane Flight Characteristics

The Safety Board consulted with deHavilland in an attempt to determine how a DHC-6-300 airplane would respond if the elevator control rod was disconnected in flight and the extent to which the airplane would be controllable under the circumstances related to the accident airplane. Because no tests had been conducted with a disconnected elevator, nor were any required by regulations, the manufacturer could only provide flight test data based on a "stick free" condition. The "stick free" condition differs from the accident condition in that the test airplane would have been affected by some friction from the flight control system, whereas the accident airplane would not have been affected because the elevator control rod would have been disconnected.

Assuming the airplane was trimmed perfectly during a representative descent, it would not change its equilibrium if the elevator was then disconnected. A power reduction to 10 p.s.i. of torque pressure probably would cause the speed to decrease 8 knots, the pitch attitude to decrease 8° to 10° nosedown, and the rate of descent to increase. This reaction probably would be only slightly different from that of the "stick free" condition. It was learned that the airplane would start to noseup when the speed began to increase in the descent. However, the airplane would not recover to a level attitude without the application of more power. The pilot could bring about a recovery within 700 feet if the maximum allowable torque was applied by about 25 seconds after the initial power reduction to 10 p.s.i. torque pressure. There is enough elevator trim control to trim the airplane to nearly its stall speed with flaps retracted. The manufacturer further reported that flight characteristics of the airplane would not have been significantly affected by the placement of the baggage pod.

1.17 Additional Information

1.17.1 Company Operations

On August 31, 1979, Sierra Pacific Airlines received an Air Carrier Operating Certificate (No. 05-WE-50) from the Federal Aviation Administration's (FAA) Air Carrier District Office (AWE-ACDO-34) in Phoenix, Arizona. The company was authorized to



Figure 14.--Detached bolt (left) with thread crowns worn at bolt's end (bracket "W"); metal debris in thread roots. Hole wall (right) in spherical bearing of control rod; debris is smeared flakes. "Inboard" arrow refers to left side of bearing. Both photographs about X10.

operate Convair CV-340 and CV-440 airplanes under Section 135.2 ^{4/} of 14 CFR Part 135. The deHavilland airplanes also were operated under 14 CFR Part 135.

The operations specifications of Sierra Pacific Airlines authorized the company to conduct flights in accordance with the provisions of the Supplemental Rules of 14 CFR Part 121 (121.41) and 14 CFR Part 135, under the terms of agreement with Transwestern Airlines. Sierra Pacific flightcrews flew Convair CV-580 and deHavilland DHC-6 type aircraft for Transwestern. Sierra Pacific was responsible for operational control of the flights covered by the agreement, which were conducted subject to the terms of its air-carrier certificate. Sierra Pacific's Flight Operations Office in Tucson, Arizona, exercised operational control and flight release authority. Company policy required flight releases for all flights, describing the conditions under which the flights were to be made. To release a flight, the Flight Operations Office and the pilot-in-command had to concur that it could be made safely in accordance with Federal regulations and company policies and procedures. The company also required that either a VFR or IFR flight plan be filed for all flights and that the plan remain in effect throughout the flight.

^{4/} Air taxi operations with large aircraft (12,500 pounds or more).

1.17.2 Company Maintenance Program

1.17.2.1 Personnel

Sierra Pacific was authorized to perform maintenance, preventive maintenance, and alterations on its deHavilland DHC-6 airplanes in accordance with Subpart J of 14 CFR Part 135 (135.411(a)(2)). As required by the regulation, the company had a Director of Maintenance, a Director of Operations, and a Chief Pilot. Although not specifically required by Part 135 (135.37), the company had designated a Director of Quality Control, primarily to carry out the responsibilities and duties of a Chief Inspector. This position is required by the Subpart C of 14 CFR Part 121, Certification Rules for Supplemental Air Carriers and Commercial Operators. Sierra Pacific decided to appoint a Director of Quality Control in part to accede to the urging of the FAA Principal Maintenance Inspector assigned to the company and in part because it was operating large transport airplanes.

The Director of Maintenance met the qualification requirements in 135.39(c). He had been employed by Intermountain Air Service for about 10 years as a Director of Quality Control, and he had held various maintenance supervisory positions with that company. He joined Sierra Pacific on January 21, 1980, and was initially employed as Director of Quality Control. He was assigned as Director of Maintenance when the current Director of Quality Control was hired in July 1981.

The Director of Quality Control had also worked for Intermountain Air Service for 6 years. He was the designated Chief Inspector for that company during his employment. He had retired from the company in 1979 and joined Sierra Pacific in July 1981 as Acting Director of Quality Control. He reported that he was hired to maintain the airplane cardex files and log sheets, make monthly maintenance forecasts, and make reports to the FAA. He stated he worked only 3 days a week.

The company employed six qualified airframe and powerplant mechanics who also had authority to perform required inspections. According to the company's General Maintenance Manual, one of the mechanics served as a maintenance supervisor responsible to the Director of Maintenance. Another mechanic served as an airline inspector, responsible to the Director of Quality Control. (See appendix E for a detailed description of the duties and responsibilities of the Director of Maintenance and Director of Quality Control.)

The company's FAA-approved aircraft inspection program for the DHC-6 provided for main base, field base, and mechanic preflight inspections. Main base inspections were to be performed at intervals not to exceed 500 hours time in service, and field base inspections were to be performed at intervals not to exceed 100 hours time in service. The company itself did not require specified calendar intervals for these inspections. The main base inspections were always performed at the company's maintenance facility at Marana Air Park, 15 miles from the company's headquarters in Tucson, Arizona. Field base inspections were performed either at the Sierra Pacific's maintenance facility or at other locations from which airplanes were operated. The office of the Director of Quality Control was located at the company's headquarters in Tucson. The company had contracted with Western Aircraft Maintenance to perform maintenance and field base inspections on N361V. Western Aircraft Maintenance is a repair station (501-3) certified to perform all airframe maintenance on both small and large aircraft; it also holds a rating for limited engine and avionics repairs.

The specifics of the required inspections of the flight control systems were similar on the Main Base Inspection form and the Field Base Inspection form. However, a May 21, 1981, revision to the Main Base Inspection form added a required inspection of flight control connecting rods in the fuselage, wings, and empennage. The control rods in the empennage were to be checked for ". . . damage, safety, corrosion and security"; bearings were to be checked for "corrosion, cleanliness and security." The Field Base Inspection form does not include this revision because the company only required it at 500-hour intervals and not at 100-hour intervals. The airplane manufacturer's maintenance inspection program, termed EMMA, consisted of 48 equalized checks performed at 100-hour intervals. The EMMA inspection schedule required a thorough examination of the flight control rods at 800-hour intervals or once each year, whichever came due first.

1.17.2.2 Recordkeeping

Federal regulations and company policy require maintenance, overhaul, and alteration of certain critical items to be designated as "Required Inspection Items". A failure or malfunction of any one of these items can render the airplane immediately unairworthy. One such critical item is major rigging and adjustment of flight controls and control surfaces. Correct maintenance of critical items is validated by a fundamental industry-wide safety practice of: (1) requiring the mechanic who performs the maintenance to sign the appropriate repair work order, and (2) having an authorized inspector who has not directly participated in the maintenance perform an inspection and also sign the repair work order.

The company's General Maintenance Manual provided specific guidance for the implementation of the maintenance and inspection program. The Director of Quality Control was responsible for inspections and maintenance recordkeeping. Various forms were used by the company to control scheduled and unscheduled maintenance, component changes, AD's, and required inspections. (See Appendix E for detailed descriptions of the forms.)

The company's General Maintenance Manual specifies procedures to insure inspection of required inspection items as follows:

Prior to proceeding with any maintenance, alteration, or inspection which includes a "Required Inspection Item", the Inspection Department will be alerted to have an authorized person available to provide the second pair of eyes. Inspection and Maintenance forms will be initiated and placed in the vicinity of the maintenance scene for ready reference and to record the work and inspections accomplished. Upon completion of the maintenance, alteration, or inspection, the forms will be examined for complete and correct entries, especially of "Required Inspection Items", before the airworthiness release is signed.

After maintenance has completed the repair order, the work is inspected by an inspector who signs the block marked "INSP." The form is then forwarded to the maintenance records department.

The manufacturer's Service Bulletin 6/390, issued February 15, 1980, made mandatory by AD 80-13-11, requires removal of the flight control rods and removal of paint and/or primer from the ends of rods for a distance of about 2 inches from the magniformed area for inspection of both ends of the rods with dye penetrant for detection

of cracks. If cracks are not detected, the rods are to be refinished with zinc chromate and painted as required. After inspection and painting, it is necessary to restamp or write in the appropriate code to indicate to be written or stamped on the part to indicate that the part has been inspected. Appropriate functional checks of the flight control system were prescribed after reinstallation of the control rods, as was the rebalancing of the elevators. The Bulletin recommends that the inspections involving removal of external paint for a visual inspection be repeated at intervals not to exceed 400 flight-hours or 6 months. The manufacturer has determined that an additional 1-ounce weight may be required after modification of the elevator connecting rod. (See appendix G for excerpts from SB 6/390.)

During the Safety Board's investigation at the company's headquarters, the Director of Quality Control was in the process of placing into a computer system all routine inspection time intervals, scheduled component change times, and required AD's. He also maintained a cardex system to record individual part changes, component AD compliance, and Service Bulletin compliance. Since his office was 15 miles from the maintenance facility at Marana Airport, all logbook pages, inspection forms, and other pertinent airplane information had to be transported to his office daily.

A review of the company's records for N361V showed that reinforcing sleeves were installed on all of the flight control rods during the inspection of the rods on February 11, 1982. (The work was started and an inspection was made on December 2, 1981, but the work was not completed until February 11, 1982.) However, there was no record clearly showing that the flight control rods had been reinstalled and the installation had been inspected. The record of the third inspection of the flight control rods reported no defects; this work was started on October 20, 1982, and completed on November 5, 1982. The forms for both the second and third inspections were signed by the same mechanic. The Director of Maintenance's inspection stamp was placed in the inspector's block of the form for the second inspection, and his initial appeared as having inspected the work during the third and last known inspection of the control rods. Although the airplane had only accumulated 350 hours between the time of the initial and second inspections, 423 days had elapsed during that time. Except for a brief test flight, the airplane did not fly between the second and third inspections. A "Work To Be Done" inspection sheet used for a check of the flight control rods during the last AD inspection on November 5, 1982, was signed by the Director of Maintenance in the mechanic's signature block. The company did not require an inspector to sign this form for the work performed. There was no record to show that the elevators were rebalanced when the sleeves were installed, as required by the Service Bulletin.

The airplane was painted between December 16, 1981, and February 3, 1982. According to the painting invoices, Sierra Pacific was responsible for removing and reinstalling the flight control surfaces. According to a maintenance form dated December 16, 1981, all flight control surfaces were to be removed from N361V for painting and balancing. The surfaces were removed the next day by the same mechanic who had accomplished the AD 80-13-11 requirements for the flight controls. However, no repair order or other record could be found to show who reinstalled the flight control surfaces on N361V after they were painted and when the work was done.

The company had been operating two other DHC-6 airplanes (N272Z and N288J) during this period. These two airplanes also were painted during the same period and were sold before the accident, because the company intended to close down the DHC-6 operation. After the accident, an inspection of the two airplanes in Puerto Rico disclosed that the elevator control rod connections to the torque tubes were fastened with the correct bolts and were properly secured with cotter pins. The bolts were installed

with the bolt heads facing the right side of the airplane (opposite that shown in figure 5). Examination of the available maintenance records for the two airplanes disclosed no record of the reinstallation of the flight controls after the airplanes were painted. Sierra Pacific later found the records relating to these two airplanes and provided copies to the Safety Board on August 11, 1983.

The accident airplane was test flown on March 12, 1982, to check the reinstallation of the flight controls; the controls were determined to have functioned normally. Review of the flight log (page No. 04057) disclosed that no maintenance person had signed the page releasing the airplane for flight. According to the company's logbook, a signed maintenance release indicated that the signer certified that: (1) all work was performed in accordance with the Maintenance Manual; (2) all required inspections were by an authorized person; (3) the airplane was in condition for safe operation; and (4) no condition was known that would render the airplane unairworthy. Also, the previous log page (No. 04056) did not contain a maintenance release signature as required by company procedure. A signature on this log page would have served to release the airplane for the test flight on March 2, 1982, according to company procedures and Federal regulation. 5/

During review of the maintenance records, the Safety Board also noted that the ELT had been removed and reinstalled on November 27, 1982, to replace the battery.

1.17.2.3 Maintenance Personnel Statements

On March 29, 1983, the Safety Board deposed the company's Director of Maintenance, the Director of Quality Control, and three mechanics at the company's offices in Tucson, Arizona. The three mechanics and the Director of Maintenance had performed maintenance and inspections on N361V. All three of the mechanics recalled participating in the reinstallation of the flight control rods on the airplane after it was painted. It took at least two mechanics to install the elevators. Only one of the mechanics stated that he remembered that someone had inspected the work, and he could not remember who performed the inspection. One stated he definitely did not install the elevator control rod. With regard to the second AD inspection of N361V, one of the mechanics recalled removing and replacing the flight control rods on all three DHC-6 airplanes; but he could not remember his specific actions with respect to N361V and could not remember who inspected the reinstallation. Another mechanic remembered removing an elevator control rod but could not recall from which airplane. He said he had performed the first and second AD inspection on all three airplanes after the rods were removed. He stated he had installed sleeves on several rods. Since he had assistance, he could not remember the control rods on which he had personally installed sleeves. However, he stated that his initials on the form of February 11, 1982, only represented that he had performed the AD inspection on flight control rods for N361V and that they were determined to be airworthy. Although the form also showed that the flight controls were rigged, he said his signature did not mean that he had reinstalled the flight controls. He further testified that on a third AD inspection of N361V and, on November 5, 1982, he did not remove the flight control rods to perform the inspection. He said the AD did not require removing the rods and, therefore, he did not inspect them with dye penetrant. He stated he used only the 10-power magnifying glass and an inspection mirror to examine the rods. When asked if he recalled being able to examine adequately the installed rods with the magnifying glass, he stated he could not recall. He also could not specifically recall who inspected the work.

The mechanic who changed the ELT battery stated that he placed the switch in the ARM position when he reinstalled the unit in the airplane.

5/ 14 CFR Part 135.443 -- Airworthiness release or aircraft maintenance log entry.

The Director of Maintenance testified that he could not locate the maintenance form documenting the installation of the elevator on N361V after it had been painted. He said he did not recall whom he might have instructed to reinstall the elevators nor who the inspector might have been. Regarding the second AD inspection, he said he inspected all of the work on the control rods performed by the mechanics, but that this inspection did not require the use of the 10-power magnifying glass. He said he checked to be sure that the inspection corresponded to the type of control rods installed in the airplane; he also looked for cracks and checked to be sure that the sleeves were installed properly. He stated that on the third AD inspection the control rods were not removed. He said that he used the magnifying glass to inspect for cracks under the sleeves while the rods were installed. When asked if he was able to use the magnifying glass with an inspection mirror he said, "yes, to the best that I can remember, yes." When asked about the "Work To Be Done," inspection sheet of November 5, 1982, he said that it was developed specifically for the 10-power magnifying glass inspection. He explained that he signed this form in the mechanics column because, according to the AD, it ". . . is not a required inspection item, because nothing was removed. That's why there was no inspector's column on this sheet." He said he signed this form because he was the last person to examine the rods.

The Director of Maintenance stated that he thought the Service Bulletin was very confusing. He said he had trouble determining which control rods had to be replaced and which ones required sleeves in order to be able to comply with a 1-year, 800-hour inspection cycle. This confusion, however, dealt mainly with the flap and aileron control rods.

A comparison of AD 80-13-11 with Service Bulletin 6/390 showed that the bulletin did not specifically require a dye penetrant reinspection with a 10-power magnifying glass after the sleeves were reinstalled. It only stated on page 4 ". . . continue visual inspections following removal of external paint. . . ." The AD directed personnel to ". . . visually inspect, using at least a ten power glass, in accordance with the above Bulletin, page 8, Figure 1." However, page 8 of the bulletin does not pertain to the inspection procedures, and Figure 1 is on page 9.

Safety Board investigators discussed these discrepancies between the AD and the Service Bulletin with the FAA. On August 4, 1983, the FAA published a revision to clarify AD 80-13-11.

On February 20, 1983, Safety Board investigators interviewed the mechanic who was in charge of maintenance on N361V for Western Aircraft Maintenance, Inc. He stated that during the last field base inspection, which he completed on February 5, 1983, no inspection covers were removed for internal examination of the flight controls, except for the hydraulic pump and control quadrant under the cockpit floor. The controls in this area were found to be airworthy. The last maintenance he performed on the airplane on February 10, 1983, related to minor items, and to the best of his knowledge no additional maintenance was performed after February 10.

1.17.3 FAA Surveillance

Operations.--At the time of the accident, the FAA was in the process of combining its General Aviation District Office (GADO) in Scottsdale, Arizona, with Air Carrier District Office (ACDO) No. 34 in Phoenix to form a Flight Standards District Office (FSDO) in Scottsdale. Although ACDO No. 34 was authorized to have three operations inspectors, it only had two at the time of the accident; it had primary certificate responsibility for three air carriers and secondary responsibility for 18 others,

some of which included the large domestic air carriers. Since Sierra Pacific also was operating in a geographic area that came under the jurisdiction of FSDO No. 67 in Salt Lake City, Utah, the manager of ACDO No. 34, on December 20, 1982, requested their surveillance assistance in operations, maintenance, and avionics. At that time, Sierra Pacific had begun operating two CV-580's and one DHC-6 from Salt Lake City.

Before the accident, the operations surveillance of Sierra Pacific centered around the CV-580 airplanes. The only DHC-6 surveillance on record involved a recurrent ground school on January 11, 1981, and two airman proficiency and qualification checks, the last of which was accomplished on December 29, 1981. FSDO No. 67 in Salt Lake City had its authorized ceiling limit of five operations inspectors. It had primary certificate responsibility for a total of 54 air carriers and secondary responsibility for 12 more under the geographic area concept. The only surveillance of Sierra Pacific performed by FSDO No. 67 was an en-route inspection of a CV-580 flight on December 28, 1982.

Maintenance.--ACDO No. 34 had three airworthiness inspectors assigned--two principal maintenance inspectors and one general maintenance inspector. A review of the maintenance surveillance records showed that this office inspected Sierra Pacific 56 times between July 2, 1981, and February 9, 1983; 39 inspections were directly associated with the CV-580 maintenance program, 7 were related to the deHavilland DHC-6 program, and 10 involved general meetings covering various other subjects. The last FAA inspection and surveillance record for N361V, dated January 26, 1983, reflected no significant adverse trends or chronic conditions in the airplane.

The Safety Board took the deposition of the FAA Principal Maintenance Inspector (PMI) assigned to Sierra Pacific Airlines. He stated that he had been assigned as assistant PMI to Mountainwest Aviation, Inc., one of the companies that had merged in 1979 to form the present Sierra Pacific Airlines, and that he became the Sierra Pacific PMI in 1979. He stated that because the maintenance personnel, airplanes, and maintenance program remained the same, a new certification of the company's maintenance department was not necessary when Sierra Pacific Airlines was formed. He said that he was satisfied with the approved program for airworthiness maintenance as it related to the company's current operation and to the manufacturer's recommended maintenance program and that he did not believe calendar checks were needed if the company strictly adhered to its program.

With regard to surveillance inspections of Sierra Pacific, the PMI stated that the last facility inspection, performed in 1982, showed only two discrepancies; both were unrelated to the accident. He said that he performed ramp inspections of the company's airplanes at its maintenance facility and that he found the airplanes to be in good condition. When asked why the CV-580 airplanes had undergone more ramp inspections than the DHC-6 airplanes, the PMI replied, ". . .because their numbers have varied from three to none and . . .I believe that the Convair had been flying more because it's been on contract with the government. . . ." He further reported that he was assigned three air carriers and one repair station and that under the FAA's area concept he had secondary responsibility for 12 to 14 other air carriers operating into Tucson.

1.18 New Investigative Techniques

None.

2. ANALYSIS

General

The flightcrew was properly certificated and qualified for the flight. The captain was highly experienced, and the first officer was a relatively inexperienced pilot. Both had been provided the off-duty time required by federal regulations. The investigation provided no evidence that the flightcrew's performance during the flight had been adversely affected by any factor. The weather conditions at the time of the accident were good, with high scattered clouds, good visibility, and a 5-knot wind from the north. Except for a control rod that was disconnected from the elevator torque tube, there was no evidence of a preimpact failure or malfunction of airframe, powerplants, or systems.

Flightcrew Performance

The flight was uneventful until the captain began to slow the airplane for descent. At that time, the captain apparently encountered a loss of elevator control when he attempted to check the normal noseover tendency of the slowing airplane.

According to the "stick free" response data provided by the manufacturer, the rate of descent of the airplane without elevator control would have increased more than that intended by the captain when he reduced power. The degree of pitch change would have depended on how well the airplane had been trimmed. According to the manufacturer's assessment, the baggage pod that had been added to the airplane would not have changed its flight characteristics. Although the forward allowable c.g. limit was exceeded by 0.7 percent, this probably had a negligible effect over the airplane's recovery characteristics at its forward allowable c.g. limit.

The inherent stability of the airplane would have caused the airplane to begin a recovery from the dive within about 700 feet. However additional power would have been required to effect a full recovery. The airplane was estimated to have been 700 feet above the ground when power was reduced. It is not known when the captain applied power during the ensuing uncontrolled descent. Statements by some of the passengers about observing the flightcrew frantically moving a big lever overhead indicated that the flightcrew was probably "varying" the power in an attempt to control the pitch attitude of the airplane. The Safety Board concludes that the captain was successful in the application of power which hastened the airplane's recovery so that it contacted the highway at a relatively flatter attitude and that this was one of the primary factors responsible for the survivability of the forced landing.

The captain could not specifically recall using elevator trim in his attempt to control the pitch attitude of the airplane. However, because trim is used almost instinctively and repeatedly by pilots to reduce flight control system forces, there is a possibility that the captain used some elevator trim during his hurried efforts to control the airplane in the seconds before impact.

Disconnected Elevator Control Rod

Preliminary on-scene examination of the wreckage disclosed that the elevator control rod was disconnected from the torque tube. The standard AN 174-12 bolt, or portions thereof, castellated nut, and cotter pin that connected the rod-end bearing to the torque tube clevis were not found. However, a bolt of similar diameter, but shorter in length than the standard bolt, was found lying within the empennage near the unattached

end of the elevator control rod. Therefore, in the absence of other mechanical discrepancies the investigation focused on the manner in which the elevator control rod became disconnected and on identification of the fastener that had been used to attach the control rod to the torque tube.

Because the ultimate design strength of an AN-174 bolt is several times the ultimate design strength of the torque tube clevis used in this connection, the clevis should have broken before the bolt was subjected to overloads. However, neither the rod-end bearing nor the clevis was damaged significantly. In a properly connected joint, the bolt grip must be of sufficient length that the bolt threads do not bear on the holes in the clevis ears. However, microscopic examination of the bolt hole in the left clevis ear, which showed areas of thread damage across the entire thickness of the wall, indicated that a bolt with an insufficient grip length had been installed or that an unsecured bolt had backed out of the clevis during control system movement. Also, with a proper connection the left clevis ear should have had circumferential markings on its outboard surface from movements of a washer, fastened nut, or a bolt head which corresponded to movements of the control rod. The thread damage to the bolt hole in the clevis and the lack of markings on the outboard surface of the clevis ear suggested that a bolt shorter than the standard AN 174-12 bolt was probably installed in the assembly, with the bolt head facing the right side of the airplane, opposite the direction shown in the manufacturer's illustrated parts catalog.

Examination of the threads of the nonstandard bolt revealed an embedded metal flake with the same chemical composition as the metal of the torque tube clevis ears. In addition, the first few thread crowns of the bolt were noticeably worn. From this evidence the Safety Board concludes that at some time the bolt came in contact with a component having the same chemical composition as that of the torque tube clevis. Had the specified bolt been used to connect the control rod, a washer and nut could not have been securely fastened onto the bolt and secured with a cotter pin.

The Safety Board finds the evidence more than sufficient to conclude that the control rod was attached to the torque tube with a nonstandard bolt, that the bolt was shorter than the one prescribed to connect the control rod to the torque tube, and that because it was shorter it could not be secured properly with a cotter pin.

While it is possible that an unsecured bolt might remain connected for 200 flight-hours, the amount of time between the painting of the airplane and the accident, it is not conceivable that the unsecured bolt could have gone undetected during a proper performance of the second follow-up AD inspection of the flight control rods. Maintenance records and personnel testimony show that reinforcing sleeves were installed during the second AD inspection. This would have required removal of the control rods and inspection after reinstallation. Consequently, an unsecured bolt should have been detected during this inspection if it had been properly done. Further, although the control rods were reportedly not removed during the third AD inspection, it is not likely that a bolt without a nut would have remained undetected during a proper inspection.

Maintenance personnel testified that the flight control rods were not removed during the third AD inspection. They believed that the AD did not require removal of the control rods in order to perform the inspection adequately. The performance of the third inspection is significant, because it was the last known time maintenance and inspections were performed on the elevator control rod. Although the instructions in the AD and the manufacturer's Service Bulletin were not completely consistent, it should have been evident to certificated mechanics that the installed flight control rods could not have

been inspected adequately with a 10-power magnifying glass, nor could paint have been adequately removed for the visual inspection with the rod installed. Because the maintenance personnel directly involved with the AD inspection were experienced, it is difficult to believe that they could have misinterpreted the instructions and the intent of both documents. However, the discrepancies between the two documents dictated some clarification; the Board is satisfied with the actions taken by the FAA since the accident to eliminate any possibility of confusion.

From the available evidence, the Safety Board could not determine who installed an improper bolt in the elevator control rod or exactly when the installation occurred. The outboard surface of the left clevis ear showed no scratch marks, but the 6-minute test flight should have left some rub marks, however slight, from a properly secured control rod. This indicates that the control rod was not properly secured when it was installed after the second AD inspection. Maintenance performed by Western Aircraft did not involve the removal of control rods and can be eliminated as a factor. Therefore, the Safety Board concludes that a breakdown in Sierra Pacific's inspection procedures occurred during the second and third AD inspections and that a poorly performed inspection failed to detect the presence of a nonstandard bolt in the connection.

Company Maintenance and Inspection Program

In an attempt to determine how a required inspection item could have been overlooked, the Safety Board reviewed the company's maintenance and inspection program. The Director of Maintenance and all of the mechanics who had performed maintenance on the airplane during the periods in question were designated inspectors. The Director of Quality Control worked part-time on recordkeeping at a location 15 miles away from the maintenance facility; he did not have any inspectors assigned to him. Because the company was in the process of closing down the DHC-6 operation, maintenance emphasis apparently was directed toward the larger and more complex CV-580 airplanes.

Although the company had adequate maintenance and inspection programs written into its General Maintenance and Inspection Manual directives, maintenance personnel failed to follow approved procedures. During his deposition the Director of Maintenance stated that he could not recall whom he had assigned to remove and reinstall the flight control surfaces on N361V before it was painted. Neither his testimony nor that of the signing mechanic contributed to a determination of who inspected the installation of the control rod following the second AD inspection. However, because the maintenance form stated, "flight controls rigged," and because the installation of the control rod was a required inspection item, it is reasonable to conclude that the Director of Maintenance's stamp in the inspector's block of the form signified that he had inspected the installation. Finally, the airplane was not released from maintenance in accordance with company procedures and federal regulations for the test flight one month after it had been painted and had undergone the second AD inspection of the flight controls.

Federal regulations 6/ mandate separation of maintenance functions and required inspection functions, and an organization adequate to perform these functions. Because the Director of Maintenance was the senior inspector for the company and the Director of Quality Control did not manage an inspection unit, the arrangement was not in

6/ 14 CFR Part 135.419 - Approved aircraft inspection program; 14 CFR Part 135.423 Maintenance, preventive maintenance, and alteration organization; 14 CFR Part 135.427 - Manual Requirements.

accord with the intent of the regulations. Although the company was not required to have a Director of Quality Control by the regulations under which it was certificated to operate, neither did it have a means for double-checking critical maintenance actions. The evidence indicated that the Director of Maintenance had assumed many of the duties and responsibilities of the Director of Quality Control, including performing required inspection functions. The Safety Board is of the opinion that the company allowed this situation to develop to the point where the safety features of the inspection program were compromised, because maintenance personnel were performing required inspection functions in a way that did not distinguish maintenance and inspection functions. This led to (at most) a cursory inspection to check that the elevator control rod was properly connected to the torque tube.

FAA Surveillance

Of the total FAA surveillance inspections of Sierra Pacific's maintenance department, only about 13 percent were directed to its DHC-6 operation, as opposed to about 70 percent for its CV-580 operation. The Safety Board believes that FAA was probably justified in performing more surveillances of the CV-580 operation than the DHC-6 operation because the company had more CV-580's in operation and flew them more frequently and because mechanically the CV-580 was more complex than the DHC-6. Even so, the Board believes that the FAA Principal Maintenance Inspector should have been aware of the limitations of the company's inspection program inherent in the part-time presence of the company's Director of Quality Control, his distance from the maintenance facility, the commingling of the mechanics' and inspectors' responsibilities, and the commingling of the duties and responsibilities of the Directors of Maintenance and Quality Control. These circumstances should have alerted him to the possibility of a compromise of safety in the maintenance department unacceptable in an air carrier operation. Based on its continuing accident and incident investigation experience, the Safety Board believes that a high level of safety in air carrier operations can only be sustained through sustained and discerning surveillance by the FAA, which was lacking in this instance.

Other discrepancies uncovered during the course of the Safety Board's investigation related to the company's operation, but they did not involve factors contributing to the accident. The flightcrew's use of average baggage weights, the use of a weight and balance form that did not require calculation and recording of the airplane's c.g., the placement of the baggage in the incorrect location in the airplane, and the cancellation of the flight plan are obvious discrepancies that should have been detected and corrected by company managers. Moreover, FAA surveillance of the company's operations could have detected these deviations from the company's FAA-approved operations manual.

Survivability

The accident was survivable. The airplane crash-landed on a level highway to the left of the centerline and was headed about 3° to the right of centerline. Analysis of the sequence of the skid marks from the landing gear, the dimensions of the airplane, and the dimensions of the highway and snowbank disclosed that the airplane's attitude at impact was 2° nosedown, about 5° right roll, and 2° to 3° left yaw.

According to the manufacturer, the damage to the landing gear compression blocks and the preload bolt indicated that design landing loads were exceeded. The vertical g load encountered at impact with the highway was estimated between 5 and 6 g's. Although the nosegear and right main landing gear absorbed the brunt of the impact forces, the break in the fuselage above the fixed main landing gear (at station FS 240)

indicated severe impact forces. Damage to the nosegear and right main landing gear and the right wing's contact with the snowbank were factors that caused the airplane to veer off the highway and into the snowbank. Once the airplane struck the snowbank, it began to cartwheel, as shown by the manner in which it broke apart. No attempts were made to determine the g loads sustained in the breakup because of the speculative nature of such calculations.

However, the primary factors responsible for the survivable nature of the accident were: (1) the captain's skill in controlling the airplane to achieve shallow pitch and roll attitudes at impact; (2) the amount of occupiable space remaining in the airplane fuselage; (3) the energy-absorbing characteristics of the packed snow; (4) the retention of the integrity of the seat tiedown and seatbelt restraint systems; (5) the flightcrew's timely warning to the passengers to fasten their seatbelts; (6) the timely response from passing motorists and rescue personnel; and (7) the fact that a fire did not erupt.

Fire was averted in part because hot engine parts on the wings were separated from the fuel tanks in the belly of the fuselage. The snow and 24° F temperature also diminished the likelihood of a flash fire.

Most of the injuries sustained in the accident were the result of forces generated in the cartwheel gyrations, even though the fuselage in the cabin area maintained its structural integrity. All of the exit doors remained operable, but the normal exit through the left rear cabin door and the left front emergency door were blocked. However, because the cockpit was demolished, passengers could easily see an escape route.

Airport personnel reported that they did not receive an ELT signal at the time of the accident. The lack of a signal was attributed to the fact that the ELT switch was found in the OFF position, because the crash impact forces were more than sufficient to have activated the ELT had the switch been in the ARM position. However, there was a possibility that the switch was moved to the OFF position by packed snow during the impact breakup sequence. On the other hand, the mechanic could have forgotten to place the switch in the ARM position after he replaced the unit in the airplane. Although accidental activations of ELT's have been a nuisance in the past and the tendency has been not to arm them until the airplane is placed in operation, the Board believes that the evidence is inconclusive as to why the switch was found in the OFF position.

3. CONCLUSIONS

3.1 Findings

1. The flightcrew was properly certificated and qualified for the flight.
2. The captain's use of power to control the airplane was a primary factor in the survivability of the forced landing.
3. The flightcrew's preflight averaging of baggage weights and load distribution and the cancellation of their flight plan were contrary to approved company procedures.
4. Except for a control rod being disconnected from the elevator torque tube, there was no evidence of a preimpact failure or malfunction of airframe, powerplants, or systems of the airplane.

5. The control rod became disconnected in flight from the elevator torque tube because of the use of a nonstandard bolt that could not be secured.
6. The installation of the elevator control rod using a nonstandard bolt probably occurred during the second AD inspections.
7. The company's inspection program failed to detect the use of a nonstandard bolt in the installation of the elevator control rod because of a breakdown in inspection procedures.
8. The failure of the company's inspection program to detect a nonstandard bolt could be attributed to the commingling of maintenance and inspection personnel duties and responsibilities.
9. The company's management personnel failed to insure the division of maintenance and inspection functions required by the company's FAA-approved maintenance program.
10. The FAA's surveillance of the company's maintenance and inspection departments was deficient in that it did not detect the commingling of maintenance and inspection duties and responsibilities within the company's maintenance department.
11. The accident was survivable.
12. Despite the fact that the fuselage maintained its structural integrity, the severe "cartwheeling" gyrations after initial impact caused the injuries sustained by the occupants.

3.2 Probable Cause

The National Transportation Safety Board determines that the probable cause of the accident was the inflight loss of elevator control following separation of the control rod from the torque tube at a connection where the company's maintenance department had used a nonstandard, unsecured bolt, which the company's inspection department had failed to detect. Contributing to the accident was the company's failure to maintain the separation of maintenance and inspection functions required by the maintenance program approved by the Federal Aviation Administration, and the failure of the FAA to detect the company's deviation from approved and maintenance procedures during surveillance inspection.

4. RECOMMENDATIONS

As a result of its investigation of this accident, the National Transportation Safety Board recommended that the Federal Aviation Administration:

Issue an air carrier maintenance bulletin to emphasize: (1) the need for air carrier airworthiness inspectors to require during the certification process that the air carrier's manuals and maintenance organizational structure conform to regulatory requirements regarding the separation of maintenance and inspection functions and (2) the need to conduct surveillance in a manner that will verify that the air carrier is performing maintenance/inspections functions and duties in accordance with the requirements. (Class II, Priority Action) (A-84-14)

BY THE NATIONAL TRANSPORTATION SAFETY BOARD

/s/ JIM BURNETT
Chairman

/s/ PATRICIA A. GOLDMAN
Vice Chairman

/s/ G. H. PATRICK BURSLEY
Member

/s/ DONALD D. ENGEN
Member

VERNON I. GROSE, Member, did not participate.

March 6, 1984

5. APPENDIXES

APPENDIX A

INVESTIGATION AND HEARING

1. Investigation

The National Transportation Safety Board was notified of the accident at 1310 e.s.t., on February 15, 1983, and immediately dispatched an investigation team to the scene. Investigative groups were established for operations, human factors, structures, powerplants, and systems/maintenance records.

Parties to the investigation were the Federal Aviation Administration, Transport Canada, Sierra Pacific Airlines, Transwestern Airlines, deHavilland Aircraft of Canada, Ltd., and Western Aircraft Maintenance, Inc.

2. Public Hearing

No public hearing was held as a result of this accident. Depositions were taken of Sierra Pacific Airlines maintenance personnel on March 29, 1983, at the company's offices at Tucson, Arizona. Parties present for the depositions were the Federal Aviation Administration, Sierra Pacific Airlines, and Western Aircraft Maintenance, Inc.

APPENDIX B

PERSONNEL INFORMATION

Captain Donald R. Moline

Captain Moline, 39, was employed by Sierra Pacific Airlines on November 22, 1982. He holds Airline Transport Pilot Certificate No. 1662441, issued November 3, 1978, with an airplane multi-engine land rating and a type rating in the DC-3. He has commercial privileges for airplane single-engine land. His current first class medical certificate, issued on November 29, 1982, contained no limitations.

Captain Moline satisfactorily passed his last proficiency check on December 12, 1982, and his last line check on December 14, 1982. At the time of the accident, he had about 12,000 flight hours, of which about 1,000 were as pilot-in-command of DHC-6 aircraft. He had flown about 3, 73, 153, and 164 hours during the 24-hour, 30-day, 60-day, and 90-day periods, respectively, preceding the accident. His duty time (flight and standby) during the 24-hours and 30 days preceding the accident was about 7 and 165 hours, respectively.

First Officer Erik M. Thorsrud

First Officer Erik M. Thorsrud, 25, was employed by Sierra Pacific Airlines on November 15, 1982. He holds Commercial Pilot Certificate No. 526416966 with airplane single-engine and multi-engine land and instrument ratings. His first class medical certificate, issued on February 9, 1982, contained no limitations.

At the time of the accident, First officer Thorsrud had about 275 flight hours, of which about 100 were in the DHC-6. He had flown about 97 hours during the previous 90 days, 86 hours during the previous 60 days, 51 hours during the previous 30 days, and 3 hours 20 minutes during the previous 24 hours. His duty time (flight and standby) during the 24-hour and 30-day period preceding the accident was about 7 hr and 104 hours, respectively. He passed his last pilot competency check on December 4, 1982.

APPENDIX C

AIRCRAFT INFORMATION

The deHavilland DHC-6-300 was type-certified in accordance with Civil Air Regulations (CAR) 3 of May 15, 1956. N361V received a standard Airworthiness Certificate (U.S.A.) in the normal category on May 16, 1973. The airplane was registered to Sierra Pacific Airlines in 1979.

The airplane was maintained under an FAA approved airworthiness maintenance program in accordance with Subpart J of 14 CFR Part 135 (135.411(a)(2)). The Safety Board reviewed several documents, including Main and Field Base inspection forms, preflight inspection forms, discrepancy (M-5) forms, repair order (M-6) forms, index cards (M-18), and the airplane flight logbook, to determine the maintenance status of the airplane. Some discrepancies were noted. As an example, the M-18 index card concerning the the AD inspection of the elevator, flap, and aileron control rods did not clearly reflect maintenance recorded on a corresponding M-6 form. The airplane flight log did not contain a maintenance release certifying its airworthiness prior to a test flight. Additionally, an M-6 form could not be found that showed the reinstallation of the flight controls after the airplane had been painted. Further review showed that all pertinent AD's up to the date of the accident had been performed. Other than the discrepancy concerning the unsecured elevator control rod, there were no other significant discrepancies discerned in the airplane.

The total air time on the airplane at the time of the accident was 4,79 hours. The last Main Base Inspection of the airplane was performed on May 28, 1981, at a total time of 4,373 hours. The last Field Base Inspection was performed on February 5, 1983, at a total time of 4,767 hours. Except for the Field Aviation, Inc. baggage pod installed on the underside of the fuselage on December 21, 1982, there were no other known modifications to the airplane that would have affected its flight characteristics.

The airplane was powered by two Pratt & Whitney PT6A-27 turboprops, serial No. PC-E4062) (left engine) and serial No. PC-E40051 (right engine). Propellers installed were Hartzell HCB3TN-30Y.

LEGEND:

- 1. Piece of Radar Dome
- 2. Captain's Door
- 3. Piece of Nose Cone & Radar Rack
- 4. Nose Gear & Crew Step
- 5. Nose Baggage Door
- 6. Baggage Pod

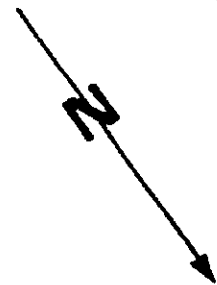

Friedman Memorial Airport
1.7 miles to Threshold of R/Y 31
Lat 43-30; Long 114-18

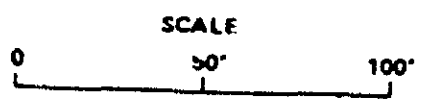
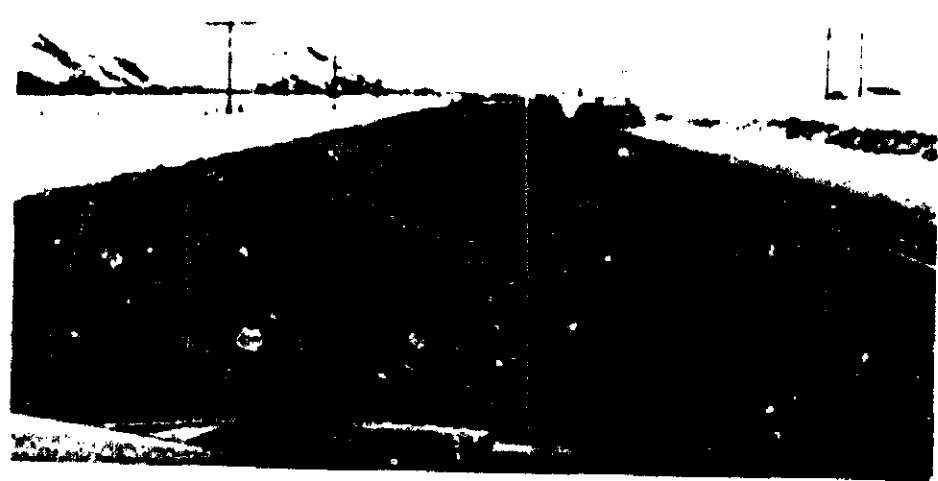
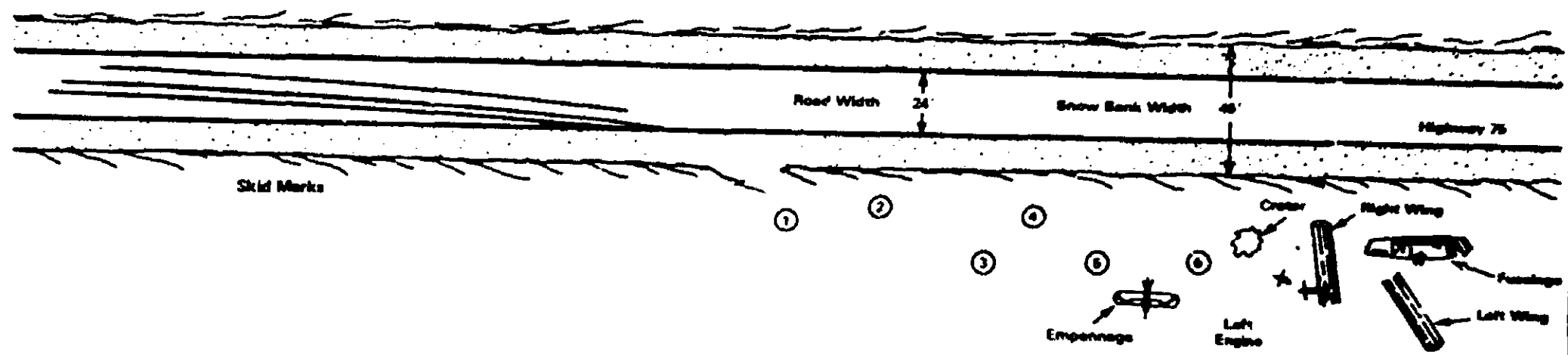

APPENDIX D
WRECKAGE DISTRIBUTION CHART

APPENDIX E

COMPANY MAINTENANCE PROGRAM

The duties and responsibilities of the Directors of Maintenance and the Director of Quality Control, outlined in the company's General Maintenance Manual, of November 18, 1981, are as follows:

Director of Maintenance

The Director of Maintenance is directly responsible to the General Manager. He monitors the airworthiness requirements of company aircraft listed in the company's Commercial Operator's Certificate and directs as necessary the maintenance functions to assure timely compliance with all FAA-mandated inspections and overhauls, and time-limited component changes. He establishes procedures to ensure an adequate stock of spare parts and petroleum supplies. He is responsible for the initiation and coordination of any emergency maintenance conducted away from the main maintenance base.

He is responsible for the adequacy of training of maintenance personnel.

Director of Quality Control

The Director of Quality Control is directly responsible to the General Manager. He ensures that all aircraft are maintained to the prescribed Operations Specifications and the Maintenance Manual.

He is responsible for maintaining quality control over company maintenance, alterations, and inspections. He ensures that each company aircraft released to service is airworthy. He maintains adequate records of aircraft time service, time charge components, and AD compliance. He acts as coordinator with the FAA in all matters concerning maintenance of the company's aircraft. He is responsible for weight and balance control, from periodic weighing to minor weight changes.

He maintains a continuing analysis and surveillance system of the company's inspection program; maintains on file all necessary FAR's, AD's and Advisory Circulars; and ensures that all amendments, revisions, and change notices are promptly incorporated into the basic manuals.

He is responsible for compiling and forwarding to the appropriate FAA Field office notifications of all premature engine removals, Mechanical Reliability and/or Mechanical Interruption Summary Reports, and other required reports whether they be routine or non-routine.

A detailed description of some of the pertinent maintenance forms follows:

M-5 Discrepancy Form--used for scheduled inspections and for the control and work on nonroutine discrepancies. It is processed by either a mechanic or, for a nonroutine discrepancy, by an inspector. The sign-off block is filled in by the mechanic for routine work or by an inspector for a required inspection item. The maintenance supervisor signs the bottom right side when all work is completed.

M-6 Repair Order Form--used to record the accomplishment of AD's, time change replacements, unscheduled maintenance, and component changes. The M-6 repair order forms are originated by a person at or above the supervisory level. The originator enters the work order and date and describes the work to be accomplished. When the work item is completed, the mechanic enters the action taken and a description of the work accomplished. He then signs the "MECH" block.

M-18 Index Card Form--used as a permanent record showing the status of an individual component, AD compliance of various parts, and time tracking of certain components or parts. The card has columns to show next due date, method of compliance, date, aircraft time, and remarks. The card is retained in the file in the records departments.

APPENDIX F

AIRWORTHINESS DIRECTIVE

Excerpts from AD 80-13-11, effective July 1, 1980, are as follows:

80-13-11 DEHAVILLAND: Amendment 39-3814. Applies to all DHC-6 model airplanes, certificated in all categories.

To prevent possible loss of control due to cracking of the elevator, flap and aileron control rods, accomplish the following:

- (a) On aircraft Serial Numbers 1 thru 430 and on those aircraft having as replacement control rods those with part numbers listed in Column 2 of Table 2 in DeHavilland Service Bulletin 6/390, within the next 50 hours in service or 30 days, whichever occurs first, after the effective date of this AD, unless previously accomplished within the last 350 hours in service or 150 days, whichever occurred last, visually inspect tube ends of the rod assemblies in accordance with the dye penetrant method using at least a ten power glass, in the above Bulletin's paragraph 8, 9, and 10 of ACCOMPLISHMENT INSTRUCTIONS, or approved equivalent.
- (b) If cracks are not or have not been found, repeat inspection in paragraph (a) within 400 hours in service or 180 days, whichever occurs first after the last inspection. Following inspection, install sleeves on rods in accordance with the above Bulletin's ACCOMPLISHMENT INSTRUCTIONS or approved equivalent and the applicable drawings and Mod numbers listed in Column 4 of Table 1.
- (d) On aircraft Serial Numbers 686 and subsequent and all other aircraft on which paragraphs (b) or (c) have been accomplished, visually inspect, using at least a ten power glass, in accordance with the above Bulletin, Page 8, FIGURE 1, at intervals not to exceed 80 hours in service or one year, whichever occurs first, from the last inspection, on all rods listed in Column 4 or 5 of Table 2 in the above Bulletin.
- (e) If cracks are found, the rod assembly must be replaced before further flight with rods of the same part number or equivalent inspected and found serviceable in accordance with paragraph (a); or with new rods of the same part number or equivalent; or with new Post-Mod rods whose parts are listed in Column 5 or 6 of Table 1 in the above Bulletin.

APPENDIX G

MANUFACTURER SERVICE BULLETIN

DHC-6 TWIN OTTER

SUBJECT:

Flight Controls - Inspection of Magneformed Flight Control Rods and Sleeve Installation - Modification No. 6/1703, 6/1718, 6/1721, 6/1734 and 6/1735.

EFFECTIVITY:

DHC-6 Aircraft Serial No. 1 and subsequent.

REASON:

An in depth study of all flying control rods other than those covered in Service Bulletin No. 6/388 has been conducted by deHavilland Aircraft to evaluate the possibility of stress corrosion cracks in the tube undetected during routine inspections, which would reduce the strength of the end fitting. The Canadian Airworthiness Authority has requested that the frequency of inspection of certain earlier rod assemblies be increased and details are included in this Service Bulletin.

DESCRIPTION:

The flight system control rods itemized in Table 1 of this Service Bulletin must be inspected for cracking at the times specified in COMPLIANCE below and following receipt of retrofit kit of parts, the two flap, four aileron and three elevator control rods are removed from the aircraft within the time stipulated in COMPLIANCE below, dye penetrant inspected for cracks and end sleeves installed at each end of each serviceable rod with the exception of the left and right-hand wing aileron outboard quadrant to bellcrank control rod which requires complete replacement with a new type rod if found cracked or at replacement time stipulated in COMPLIANCE below. The rods are then reinstalled on the aircraft, the elevator balance checked and if required, a 1 oz. weight added. The control systems are then function tested. The inspection requirements of the control rods installed with subject sleeves and of other magneformed end rods itemized in Table 2, are detailed below under COMPLIANCE and is the subject of Temporary Revision No. 8 to the Inspection Requirements Manual PSM 1-6-7.

COMPLIANCE:

1. For Aircraft Serial No. 1 thru 430:

- (a) Unless control rod assembly has been replaced by a post Modification No. 6/1486 (Rudder system), No. 6/1487 (Flap system), 6/1488 (Elevator system) or 6/1489 (Aileron system) component, within 100 flying hours from receipt of this Service Bulletin unless already accomplished within the last 300 flying hours, remove external paint and carry out a visual inspection on all rod assemblies listed in Table 2 Column 4 (i.e., 2024-T3 rods). Repeat inspection at intervals not to exceed 400 flight hours or 6 months.

February 15th, 1980
Revision 'A' June 9th, 1980

S/B No. 6/390
6-27-7
Page 1 of 11

COMPLIANCE:

1. For Aircraft Serial No. 1 thru 430:
 - (b) Incorporate Modifications Nos. 6/1703, 6/1718 and 6/1721, 6/1734 and 6/1735 as detailed in ACCOMPLISHMENT INSTRUCTIONS below on the applicable rod assemblies listed in Table 2 Column 2 within 6 months from date of initial issue of this Service Bulletin.
 - (c) Remove external paint and visually inspect any post Modification No. 6/1486, 6/1487, 6/1488 or 6/1489 rod assemblies listed in Table 2 Column 5 (i.e., retrofitted 2024-T81 rods) at intervals of 800 flying hours or 1 year whichever occurs first.
2. For Aircraft Serial No. 431 thru 685:
 - (a) Remove external paint and visually inspect control rod assemblies listed in Table 2 Column 5 as detailed in ACCOMPLISHMENT INSTRUCTIONS below, at intervals of 800 flying hours or 1 year whichever occurs first.
 - (b) Unless embodied during manufacture (Aircraft prior to Serial No. 686), incorporate Modification No. 6/1703, 6/1718, 6/1721, 6/1734 and 6/1735 as required, on the applicable control rod assemblies listed in Table 2 Column 3 as detailed in ACCOMPLISHMENT INSTRUCTIONS below, no later than 1 year from date of initial issue of this Service Bulletin.
 - (c) If a pre Modification No. 6/1486, 6/1487, 6/1488 or 6/1489 control rod (2024-T3) has been installed as a replacement component, the inspection requirement and modification installation as detailed in paragraph 1(a) and (b) above will apply.
3. The visual inspections noted above in paragraph 1(a) and 2(a) as applicable, shall be continued following incorporation of modifications by retrofit or installed prior to aircraft delivery. See Temporary Revision No. 8 of Inspection Requirements Manual PSM 1-6-7.

APPROVAL:

The design content conveyed by this Service Bulletin has been approved by the Chief, Airworthiness, Canadian Department of Transport.

This Service Bulletin is required for and forms part of Canadian Department of Transport AD CF-80-03 dated February 21st, 1980 or later issue approved by Chief, Airworthiness, Canadian Department of Transport.

MANHOURS:

Approximately fifty manhours will be required to inspect and install all sleeves contained in the subject modification.

KIT COSTS:

For the purpose of simplicity, the required kit content for the installation of Modification No. 6/1703, 6/1718 and 6/1721 is introduced by a common designation E.O. 66828. The kit content for installation of Modification No. 6/1734

February 15th, 1980
Revision 'A', June 9th, 1980

S/B No. 6/39C
6-27-7
Page 2 of 11

KIT COSTS: cont'd

...and 6/1735 will be designated by C6MK1734-1 and C6MK1735-1 respectively.

Kit E.O. 66828-51 (sleeves).....\$257.63 per A/C
(Budgetary)
Kit E.O. 66828-53 (sleeves)\$227.32 per A/C
Kit E.O. C6MK1735-1 (sleeves)\$ 89.67 per A/C
Kit C6MK1734-1 (Control Rod less Bearing)\$448.27 per A/C

(Price is F.O.B. Toronto and in Canadian Funds. Subject to change without notice).

Kits E.O. 66828-51 or -53, C6MK1734-1 and C6MK1735-1 will be supplied for Serial No. 1 thru 430 only on a no-cost basis with kits E.O. 66828-51 and -53 currently in process of being dispatched.

Kits E.O. 66828-51 or -53 for Aircraft Serial No. 431 thru 684 may be purchased from deHavilland Spares Department.

Kits C6MK1734-1 and C6MK1735-1 for Aircraft Serial No. 431 thru 685 may be purchased from deHavilland Spares Department.

WEIGHT AND BALANCE:

Weight/lb	Arm/in	Moment	$\frac{\text{lb/in}}{100}$
+ .286	288.8		+ 0.8

PUBLICATIONS AFFECTED:

Illustrated Parts Catalogue PSM 1-6-4 and PSM 1-63-4
Inspection Requirements Manual PSM 1-6-7
Modification and Options Manual PSM 1-6-12

REFERENCES:

Canadian Department of Transport Airworthiness Directive
No. CF-80-03 dated February 8, 1980
Federal Aviation Administration Airworthiness Directive
80-13-11 Amendment 39-3814, effective date July 1, 1980

ACCOMPLISHMENT INSTRUCTIONS:

1. INSPECTION

- 1.1 Following receipt of this Service Bulletin, remove external paint and visually inspect all control rods itemized in Table 2 Columns 4 and 5 to the time requirements detailed in COMPLIANCE above.
- 1.2 Immediately prior to installation of sleeves on affected control rods, carry out a dye penetrant inspection as detailed in ACCOMPLISHMENT INSTRUCTIONS below.

February 15th, 1980
Revision 'A', June 9th, 1980
Revision 'B', July 18th, 1980

S/B No. 6/390
6-27-7
Page 3 of 11

ACCOMPLISHMENT INSTRUCTIONS: cont'd

1. INSPECTION:

1.3 Following installation of sleeves, continue visual inspections following removal of external paint on control rods listed in Column 4 and 5 of Table 2, to the time requirements detailed in COMPLIANCE above.

2. INSTALLATION:

The following instructions are relevant to all affected aircraft and constitute the inspection of control rods and installation of the required sleeves. Installation of sleeves is not practical on the aileron control rod C6CW1018-1 or -3 and if found cracked, or at replacement time stipulated in COMPLIANCE above, must be replaced with a new control rod C6CW1080-1 or C6CW1080-27 (less bearing). Note that installation instructions for all control rods less bearings supplied to operators, is given in deHavilland Service Bulletin No. 6/393.

1. Remove elevator control rod access panel No. 11 on rear fuselage. Refer to Maintenance Manual PSM 1-6-2 Part 1 or PSM 1-63-2 Chapter 12-00-00.
2. Remove elevator control rod C6CF1141-1 or -3 (elevator quadrant rear fuselage) and retain hardware. Refer to Illustrated Parts Catalogue PSM 1-6-4 Part 2 or PSM 1-63-4 Chapter 27-30-00.
3. Remove elevator trim tab access panel No. 27 (left and right-hand) on underside of each elevator. Refer to Maintenance Manual PSM 1-6-2 or PSM 1-63-2 Chapter 12-00-00.
4. Remove elevator trim tab control rod C6CT1014-1 or -3 (screwjack to tab) from left-hand elevator and retain hardware. Refer to Illustrated Parts Catalogue PSM 1-6-4 Part 2 or PSM 1-63-4 Chapter 27-30-00.
5. Remove elevator/flap trim tab control rod C6CT1015-1 or -3 (screwjack to tab) from right-hand elevator and retain hardware. Refer to Illustrated Parts Catalogue PSM 1-6-4 or PSM 1-63-4 Chapter 27-30-00.
6. Remove flap and aileron control rod access panels No. 37 and 38 on underside of left and right-hand wings. Refer to Maintenance Manual PSM 1-6-2 Part 1 or PSM 1-63-2 Chapter 12-00-00.
7. Remove flap control rod C6CW1017-3 or -7 (bellcrank to flap), aileron control rod C6CW1019-1 or -3 (bellcrank to aileron) and aileron control rod C6CW1018-1 or -3 (quadrant to bellcrank) from left and right-hand wings and retain hardware. Refer to Illustrated Parts Catalogue PSM 1-6-4 Part 2 or PSM 1-63-4 Chapter 27-50-00 and 27-10-00.
8. Remove paint and/or primer from ends of each rod using Turco 5469 or Cee-Bee R256A or equivalent paint stripper, to a distance of approximately 2.0 inches from magneformed area.

February 15th, 1980
Revision 'A', June 9th, 1980
Revision 'B', July 18th, 1980

S/B No. 6/390
6-27-7
Page 4 of 11

ACCOMPLISHMENT INSTRUCTIONS: cont'd

2. INSTALLATIONWARNING

8. Be careful not to remove the anodic finish on rods. Rods with the anodized finish removed must be rejected.
9. Carry out a dye penetrant inspection on both ends of each rod assembly. Replace rod if cracks are detected. Refer to Figure 1 for view of typical crack that might be found.
10. On rods which are free of cracks following inspection, replace finish using zinc chromate primer and paint as required.

NOTE

Operators in U.S.A. will receive a kit which does not contain the primer. The primer should be procured locally.

11. Refer to drawing C622052, C622061, C622058, C622065 or C622066 and install a sleeve CSP358-4-5-6 or -8 as applicable on each end of each rod assembly C6CF1141-1 or -3, C6CW1017-3 or -7, C6CW1019-1 or -3, C6CT1014-1 or -3 or C6CT1015-1 or -3, by slipping sleeve over each rod end fitting. In some cases, it will be necessary to remove the adjustable rod end bearing in order to fit the sleeve over the tube. Maintain adjustment position to simplify later rigging check. Position sleeve flush with junction of end fitting and magneformed area of rod. Use sealant DHMS S3.01/82 to secure sleeve and fill the four holes in each sleeve with sealant. Remove excess sealant. Serviceable aileron control rod C6CW1018-1 or -3 may be replaced on the aircraft as is and continue in operation until replacement is required as outlined in COMPLIANCE above.

NOTE

1. Operators in U.S.A. will receive a kit which does not include the sealant. For procurement of sealant refer to KIT OF MATERIALS below.
2. Retain unused sealant for future installation of sleeves that might not be actioned at this time.
12. Rubber stamp or write C622052-1 alongside current part number on elevator control rod C6CF1141-1 and C622052-3 alongside current part number on control rod C6CF1141-3.
13. Rubber stamp or write C622061-1 alongside current part number on flap control rod C6CW1017-3 and C622061-3 alongside current part number on control rod C6CW1017-7.
14. Rubber stamp or write C622058-1 alongside current part number on aileron control rod C6CW1019-1 and C622058-3 alongside current part number on control rod C6CW1019-3.

February 15th, 1980
 Revision 'A', June 9th, 1980
 Revision 'D', March 27th, 1981

S/B No. 6/390
 6-27-7
 Page 5 of 11

ACCOMPLISHMENT INSTRUCTIONS: cont'd

2. INSTALLATION.

15. Rubber stamp or write C622065-1 alongside current part number on elevator trim tab control rod C6CT1014-1 and C622065-3 alongside current part number on control rod C6CT1014-3.
16. Rubber stamp or write C622066-1 alongside current part number on elevator flap trim tab control rod C6CT1015-1 and C622066-3 alongside current part number on control rod C6CT1015-3.
17. Reinstall all control rods removed in paragraphs 2, 4, 5 and 7 above. Check rigging of each affected system.
18. Balance check elevators in accordance with procedures detailed in Repair and Overhaul Manual PSM 1-6-3 Chapter 55-20-00. It has been determined that an additional one ounce weight will possibly be required upon completion of modification. Operators may balance check elevators and add weight as required or alternatively forego the balance check and automatically add the one ounce weight. This may be accomplished by adding a piece of aluminum to the same dimensions as existing lead weights (6.70 x 1.75) and 0.062 inch thick.
19. Function test flap, aileron and elevator systems and replace all access panels.
20. On incorporation of Modification No. 6/1703, 6/1718, 6/1721 and 6/1735, make the following entry in the "Record of Airframe Modifications" or equivalent document: "Service Bulletin No. 6/390 - Installation of Sleeve on Elevator, Flap and Aileron Control Rods - Modification No. 6/1703, 6/1718, 6/1721 and 6/1735, incorporated." Make an appropriate entry for Modifications installed if not all accomplished simultaneously.
21. On incorporation of Modification No. 6/1734 make the following entry in the "Record of Airframe Modifications" or equivalent document: "Service Bulletin No. 6/390 - Installation of New Aileron Control Rod - Modification No. 6/1734, accomplished".

KIT OF MATERIALS:

- (a) Kit EO 66828-51 - Sleeve Installation to Flap, Aileron and Elevator Control Rods

Kit EO 66828-53 - Sleeve Installation to Flap, Aileron and Elevator Control Rods

- (b) Detailed Kit Content:

Part No.	Qty per A/C	-51		Description	Replaces Part No.	Remarks
		-53				
EO 66828 Sheet 3	1	1		Kit List		
C6MK1703	1	1		Drawing Kit		

February 15th, 1980
 Revision 'A', June 9th, 1980
 Revision 'D', March 27th, 1981

S/B No. 6/390
 6-27-7
 Page 6 of 11

KIT OF MATERIALS: cont'd

(b) Detailed Kit Content:

Part No.	Qty per A/C		Description	Replaces Part No.	Remarks
	-51	-53			
C622052	1	1	Drawing - Rework		
CSP358-4	2	2	Sleeve 4 - 8"		
C6MK1718	1	1	Drawing, - Kit		
C622058	1	1	Drawing - Rework		
CSP358-5	4	4	Sleeve 4		
C6MK1721	1	1	Drawing - Kit		
C622061	1	1	Drawing - Rework		
CSP358-6	4	4	Sleeve - 8" 4		
TT-P-1757	1	-	Primer 1/2 pint can		
OHMS 53.01/82	1	-	Sealant 1/2 pint		

NOTE

The above kit represents Modifications
No. 6/1703, 6/1718 and 6/1721 only.

(c) Kit C6MK1735-1 - Sleeve Installation for Elevator Trim Tab Control Rods

Kit C6MK1734-1 - Installation of new Aileron Control Rod (less bearing)

(d) Detailed Kit Content:

Part No.	Qty per A/C		Description	Replaces Part No.	Remarks
	C6MK1735-1				
C6MK1735	1		Drawing - Kit		
C622065	1		Drawing Rework		
C622066	1		Drawing Rework		
CSP358-8	4		Sleeve		

NOTE

The above kit represents Modifi-
cation No. 6/1735 only.

February 15th, 1980
Revision 'A', June 9th, 1980

S/B No. 6/390
6-27-7
Page 7 of 11

KIT OF MATERIALS: cont'd
(d) Detailed Kit Content:

<u>Part No.</u>	<u>Qty per A/C C6MK1734-1</u>	<u>Description</u>	<u>Replaces Part No.</u>	<u>Remarks</u>
C6MK1734	1	Drawing - Kit		
C622070	1	Drawing - Rework		
C6CW1080-27	2	Push Rod		
C6CWM1043-27	2	Pin		
MS20470AD3-13	2	Rivet		

NOTE

The above kit represents Modification No. 6/1754 only.

For U.S.A. operators who will not receive the primer and sealant in their kit due to governing regulations, it is noted that the U.S. Federal Specification for zinc chromate primer is TT-P-1757.

For U.S. operators receiving retrofit kits that do not include the DHMS S3.01/B2 Sealant, the following alternatives are listed:

(e) Material Procurement Information:

PR1422-B2 Product Research Chemical Corporation
2429 Empire Avenue,
BURBANK, California, U.S.A.

or

410-416 Jersey Avenue,
Gloucester City, New Jersey, U.S.A.

EC1675-B2 Minnesota Mining and Manufacturing Co.,
Adhesives Coatings and Sealers Division,
3M Center St. Paul, Minn. 55101, U.S.A.

CS3204 B2 Chem Seal Corporation,
11120 Sherman Way,
Sun Valley, California 91352, U.S.A.

Pro-Seal 890-82 Essex Chemical Corporation,
19451 Susana Road,
COMPTON, California 90221, U.S.A.

February 15th, 1980
Revision 'A', June 9th, 1980

S/B No. 6/390
6-27-7
Page 8 of 11

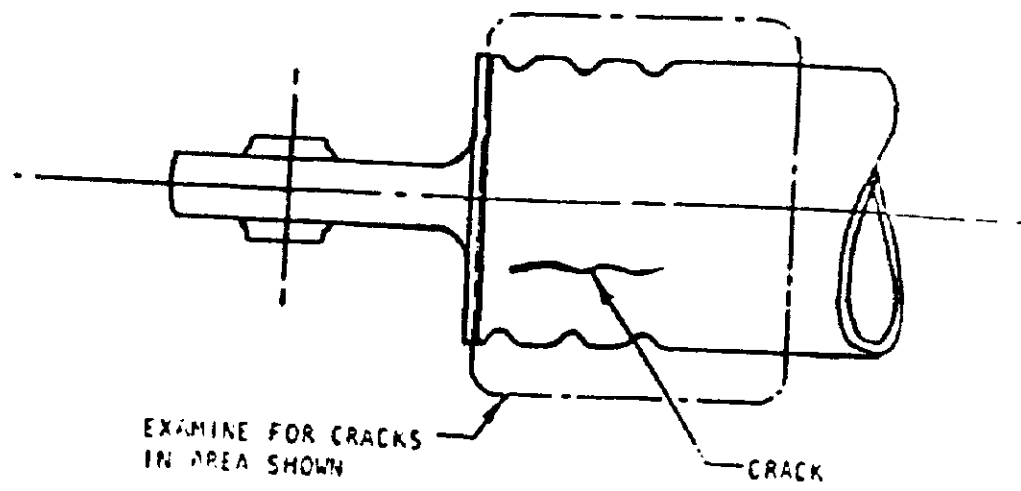

TYPICAL TUBE WITHOUT SLEEVE

ANY CRACK WITHIN THE INSPECTION AREA SHOWN IS REASON FOR REJECTION OF ROD.

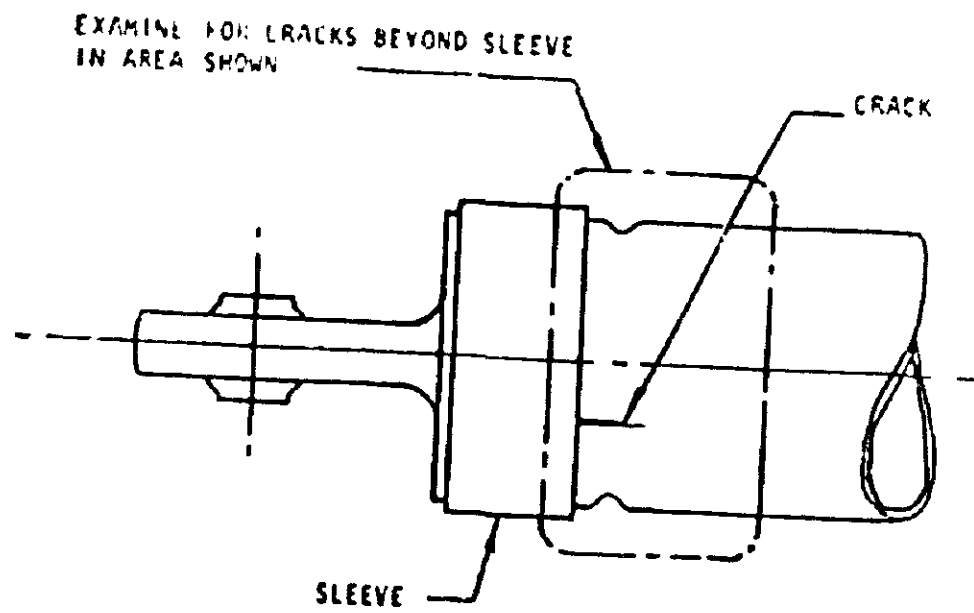

INSPECT FOR POSITION AND SECURITY

TYPICAL TUBE WITH SLEEVE

ANY CRACK WITHIN THE INSPECTION AREA SHOWN IS REASON FOR REJECTION OF ROD.

February 15th, 1980
Revision 'A', June 9th, 1980
Revision 'C' February 2nd, 1981

FIGURE 1

S/B No. 6/330
6-27-7
Page 9 of 11

February 15th, 1980
Revision 'A' June 9th, 1980

Revision 'C' February 2nd, 1981

S/B No. 6/390
6-27-7
Page 10 of 11

EQUIVALENT PART NUMBERS					
	Pre-Mod 6/1487	Post Mod 6/1487	Pre-Mod 6/1487 6/1488 and 6/1489 rod retrofitted with Mod No. 6/1703, 6/1703, 6/1721, 6/1734 and 6/1735	Post Mod 6/1487 6/1488 and 6/1489 rod retrofitted with Mod No. 6/1703, 6/1718, 6/1721 6/1734 and 6/1735	Post Mod 6/1703 6/1718, 6/1721, 6/1734 and 6/1735 New Production Rods
Installed during build in Aircraft Serial No.	1-430	431 - 684			685 and subs
Elevator Quadrant to Elevator Torque Tube	C6CF1141-1	C6CF1141-3	C6CF1141-1 and C6Z2052-1	C6CF1141-3 and C6Z2052-3	C6CF1461-1
Outboard Bellcrank to Flap	C6CW1017-3	C6CW1017-7	C6CW1017-3 and C6Z2061-1	C6CW1017-7 and C6Z2061-3	C6CW1077-1
Outboard Bellcrank to Aileron	C6CW1019-1	C6CW1019-3	C6CW1019-1 and C6Z2058-1	C6CW1019-3 and C6Z2058-3	C6CW1076-1
Aileron Outboard Quadrant to Bellcrank	C6CW1018-1	C6CW1018-3	*C6CW1080-1	*C6CW1080-1	*C6CW1080-1
Elevator Trim Tab - Screwjack to Tab	C6CT1014-1	C6CT1014-3	C6CT1014-1 and C6Z2065-1	C6CT1014-3 and C6Z2065-3	C6CT1042-1
Elevator Flap/Elevator Interconnect - Screwjack to Tab	C6CT1015-1	C6CT1015-3	C6CT1015-1 and C6Z2066-1	C6CT1015-3 and C6Z2066-3	C6CT1043-1
Col. 1	Col. 2	Col. 3	Col. 4	Col. 5	Col. 6
	2024-T3 Material Without Sleeves	2024-T81 Material Without Sleeves	2024-T3 Material With Sleeves Retrofitted	2024-T81 Material With Sleeves Retrofitted	2024-T81 Material With Sleeves New Production

*New Rod Replacing C6CW1018-1 and -3

TABLE 1

February 15th, 1980
Revision 'A', June 5th, 1980

Control Rod Location	Rods - (Retrofit Action)		Rods Requiring Inspection	
	2024-T3 Material	2024-T81 Material	2024-T3 Material Rods	2024-T81 Material Rods
Elevator Quadrant to Torque Tube	C6CF1141-1 Original (Sleeve Inst)	C6CF1141-3 Original (Sleeve Inst)	C6CF1141-1 Original C6Z2052-1 Retrofit	C6CF1141-3 Original C6Z2052-3 Retrofit C6CF1461-1 (New Prod) ✓ /
Outboard Bellcrank to Flap	C6CW1017-3 Original (Sleeve Inst)	C6CW1017-7 Original (Sleeve Inst)	C6CW1017-3 Original C6Z2061-1 Retrofit	C6CW1017-7 Original C6Z2061-3 Retrofit C6CW1077-1 (New Prod) ✓ 2
Outboard Bellcrank to Aileron	C6CW1019-1 Original (Sleeve Inst)	C6CW1019-3 Original (Sleeve Inst)	C6CW1019-1 Original C6Z2058-1 Retrofit	C6CW1019-3 Original C6Z2058-3 Retrofit C6CW1076-1 (New Prod) 2
* Aileron Outboard Quadrant to Bellcrank	C6CW1018-1 Original (Replace with new rod C6CW1080-1)	C6CW1018-3 Original (Replace with new rod C6CW1080-1)	C6CW1018-1 Original C6CW1080-1 Retrofit C6CW1080-1 (New Prod)	C6CW1018-3 Original C6CW1080-1 Retrofit C6CW1080-1 (New Prod) 2
Elevator Trim Screw-Jack to Tab	C6CT1014-1 Original (Sleeve Inst)	C6CT1014-3 Original (Sleeve Inst)	C6CT1014-1 Original C6Z2065-1 Retrofit	C6CT1014-3 Original C6Z2065-3 Retrofit C6CT1042-1 (New Prod.) ✓ /
Elevator Flap Interconnect - Screwjack to Tab	C6CT1015-1 Original (Sleeve Inst)	C6CT1015-3 Original (Sleeve Inst)	C6CT1015-1 Original C6Z2066-1 Retrofit	C6CT1015-3 Original C6Z2066-3 Retrofit C6CT1043-1 (New Prod) ✓ /
Inboard Flap Rod Bellcrank to Flap	* C6CW1017-1 Original A/C 1 thru 35 (No retrofit)	-----	C6CW1017-1 Original A/C 1 thru 35	-----
Rudder Gear Tab Mechanism	C6CF1173-1 Original (No retrofit)	C6CF1173-3 Original (No retrofit)	C6CF1173-1 Original	C6CF1173-3 Original
Rudder Trim Screw jack to Tab	C6CT1013-1 Original (No retrofit)	C6CT1013-3 Original (No retrofit)	C6CT1013-1 Original	C6CT1013-3 Original
Col. 1	Col. 2	Col. 3	Col. 4	Col. 5

TABLE 2 - CONTROL ROD INSPECTION

NOTE: At Revision 'A' Col 2 and 3 retitled and expanded for clarity

* Rod C6CW1017-1 may be replaced with steel rod C6CW1017-1 (Modification No. 6/1011)

S/O No 6/35
6-27-
Page 11 of