

## An unexpected pattern of molecular divergence within the blue penguin (*Eudyptula minor*) complex

JONATHAN C. BANKS\*

ANTHONY D. MITCHELL

Ecology and Entomology Group, Lincoln University, P.O. Box 84, Lincoln University, New Zealand

JOSEPH R. WAAS

Department of Biological Sciences, University of Waikato, Private Bag 3105, Hamilton, New Zealand

ADRIAN M. PATERSON

Ecology and Entomology Group, Lincoln University, P.O. Box 84, Lincoln University, New Zealand

\*Corresponding author: [banksj@lincoln.ac.nz](mailto:banksj@lincoln.ac.nz)

**Abstract** The blue penguins (genus *Eudyptula*) have been subjected to extensive taxonomic revision. In 1976, the genus was reduced from 2 species to a single species (*Eudyptula minor*) with 6 subspecies, based on a morphometric analysis. Despite the later proposed rejection of the differentiation of subspecies in *Eudyptula minor*, following analysis of allozymes in some populations, the 6 subspecies have continued to be recognised in some popular and scientific literature. We compared the sequences of 3 mitochondrial gene regions (small ribosomal subunit, cytochrome oxidase *b* and the control region) from the 6 hypothesised subspecies to examine relationships within *Eudyptula*. We found evidence for 2 unexpected clades: the 1st consisting of Otago and Australian populations, the 2nd consisting of northern, Cook Strait, Chatham Island, and Banks Peninsula populations. Some support for these 2 clades was also found from a re-analysis of morphometric data and from a preliminary examination of vocalisations.

Banks, J.C.; Mitchell, A.D.; Waas, J.R.; Paterson, A.M. 2002. An unexpected pattern of molecular divergence within the blue penguin (*Eudyptula minor*) complex. *Notornis* 49(1): 29-38.

**Keywords** systematics; mitochondrial DNA; Sphenisciformes; *Eudyptula*; control region

### INTRODUCTION

Blue penguins (genus *Eudyptula*) are the smallest living penguins, occurring in temperate seas around the coasts of New Zealand and the eastern and southern coasts of Australia (Marchant & Higgins 1990). The taxonomy of *Eudyptula* has been subjected to extensive revision since *Eudyptula minor* (Forster, 1781) was described from a specimen collected in Dusky Sound, South Island, New Zealand (Turbott 1990). A 2nd species, the white-flipped Penguin (*E. albosignata* Finsch, 1874), was described from a specimen collected from Akaroa Harbour, Banks Peninsula (Turbott 1990).

Kinsky & Falla (1976), using morphometric data, reclassified the *Eudyptula* penguins into a single species containing 6 subspecies. Of the subspecies they recognised, *E. m. iredalei* bred around the northern North Island, *E. m. variabilis* around the southern North Island and Cook Strait, *E. m. chathamensis* on the Chatham Islands, *E. m. minor* around Otago, Southland, and the West Coast of South Island, *E.*

*m. albosignata* on Banks Peninsula and Motunau Island, and *E. m. novaehollandiae* in Australia (Fig. 1).

Turbott (1990) interpreted analyses of allozyme data (Meredith & Sin 1988a, b) to show that such a high degree of intra- and inter-population variability existed within *Eudyptula* that no subspecies could be recognised. This lumping was criticised in Marchant & Higgins (1990) because Meredith & Sin (1988a, b) had not analysed specimens from the ranges of *E. m. minor*, *E. m. chathamensis*, or *E. m. novaehollandiae* and had sampled only a few localities within the ranges of the 3 remaining subspecies. Despite Turbott's (1990) reclassification, there has been little consensus as to whether the various taxa represent 2 distinct species (Kinsky 1970), 1 species with 6 subspecies (Kinsky & Falla 1976), or a single, morphologically variable species (Turbott 1990), and use of the Kinsky & Falla (1976) classification has persisted in the popular and scientific literature, for example in Dennis (1999) and Marchant & Higgins (1990).

Animal mitochondrial DNA is maternally inherited and does not recombine (Hillis *et al.* 1996). Mitochondrial DNA clades within many species have

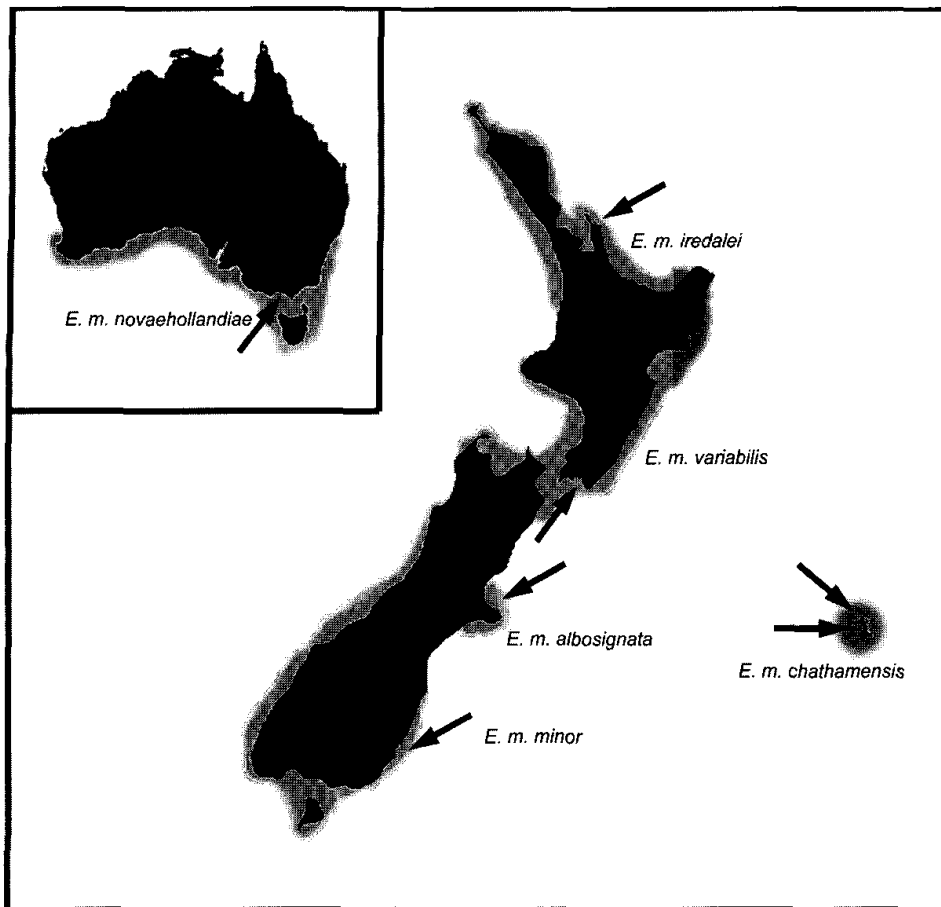

**Fig. 1** Geographic ranges (shaded) of subspecies from Kinsky & Falla (1976). Arrows indicate sampling locations.

been shown to be geographically localised (Avisé 1994) and, depending on the gene region selected, sequencing can detect variation between populations that allozyme analysis may fail to detect (Sunnucks 2000). In an attempt to resolve the confusion over the systematics of the *Eudyptula* penguins, we compared the sequences of 3 mitochondrial gene regions: the relatively less variable small ribosomal subunit (12S) and cytochrome oxidase *b* (*cytb*) gene regions, and the relatively highly variable control region (CR) of individuals from within the distributions of all 6 hypothesised subspecies. We also analysed morphometric data from the literature and examined vocalisations to further investigate relationships within *Eudyptula*.

## METHODS

### Genetics

Tissue was obtained from blue penguins found dead or from feathers removed from live birds (Table 1). Live birds were released unharmed after the feather was removed. Handling of birds was approved by the Lincoln University Animal Ethics Committee, the retention of tissue by the Wellington, Chatham Islands, and Canterbury conservancies of the Department of Conservation, and the export of tissue from Australia was approved by

Natural Resources and Environment Victoria and Environment Australia.

DNA was extracted using the high salt method (White *et al.* 1990) from the tip of the feather shaft or 15 mg of muscle tissue from carcasses. We amplified a portion of 12S, *cytb* and CR from the mitochondrial genome from total genomic extracts using the polymerase chain reaction (PCR). All PCR was carried out using a Perkin Elmer 2400 thermal cycler. Primers and reaction profiles for each region were as follows: the 12S region was amplified using the primers 12sai and 12sbi (Simon *et al.* 1994) at 94°C for 4 min, 40 cycles of 94°C for 20 s, 55°C for 30 s, 72°C for 50 s, and finally 72°C for 5 min. *Cytb* was amplified using primers DCL1 and DH15149 (K. Tsuda pers. comm.) with the reaction conditions 94°C for 4 min, 40 cycles of 94°C for 40 s, 55°C for 40 s, 72°C for 40 s, and 72°C for 5 min. The control region was amplified using primers LtRNA and Hdbox (Ritchie 2001) with the reaction conditions 94°C for 4 min, 30 cycles of 94°C for 10 s, 57–62°C (depending on the taxon) for 10 s, 72°C for 35 s, and finally 72°C for 5 min. For PCR, 2.5 ml of 10x buffer (Roche), 2.5 ml of dNTPs (1mM), 2ml of MgCl<sub>2</sub> (25mM), 1 ml of each primer (10mM), 0.25 ml *Taq* (Roche), 0.5–1 ml of DNA and water to 25 ml were used for each reaction. Negative controls were incorporated in each amplification round using water rather than DNA.

**Table 1** Population designation ("Common name"), geographical location, sample type (source), and number of specimens (n) of blue penguins (*Eudyptula minor*) used in analyses.

Subspecies	"Common" name	Sample location	Source	n
<i>E. m. iredalei</i>	Northern	Coramandel Peninsula, Auckland	Carcase	2
<i>E. m. variabilis</i>	Cook Strait	Wellington Harbour	Feather	2
<i>E. m. chathamensis</i>	Chatham Island	Cape Young, Chatham Island	Feather	1
	Chatham Island	Red Bluff, Chatham Island	Feather	1
<i>E. m. albosignata</i>	Banks Peninsula	Harris Bay, Banks Peninsula	Carcase	1
	Banks Peninsula	Flea Bay, Banks Peninsula	Carcase	1
<i>E. m. minor</i>	Otago	Pilots Beach, Otago	Carcase	1
	Otago	Saint Clair Beach, Otago	Carcase	1
<i>E. m. novaehollandiae</i>	Australia	Phillip Island, Victoria, Australia	Carcase	2

**Table 2** Mean of measurements (weight, g; length, depth, mm) of samples from different populations of blue penguins (*Eudyptula minor*), from Kinsky & Falla (1976), Marchant & Higgins (1990) used in cluster analysis.

MALES											
Population	Weight	Bill length	Relative bill length	Bill depth	Relative bill depth	Flipper length	Relative flipper length	Tarsus length	Relative tarsus length	Toe length	Relative toe length
Otago	1243.7	38.9	0.031278	15.2	0.012222	124.2	0.099863	18.56	0.014923	55.2	0.044384
Banks Peninsula	1357.5	39	0.028729	17.04	0.012552	126	0.092818	21.01	0.015477	54.5	0.040147
Chatham Islands	1190	38.17	0.032076	18.3	0.015378	124.25	0.104412	21.2	0.017815	56.2	0.047227
Cook Strait	1167.7	37.4	0.032029	16	0.013702	124.5	0.10662	20.9	0.017898	54.2	0.046416
Northern	934.6	35.8	0.038305	14.29	0.01529	116.3	0.124438	18.6	0.019902	49.67	0.053146
Australia	1172	37.7	0.032167	14	0.011945	120.4	0.10273			50.7	0.043259
FEMALES											
Population	Weight	Bill length	Relative bill length	Bill depth	Relative bill depth	Flipper length	Relative flipper length	Tarsus length	Relative tarsus length	Toe length	Relative toe length
Otago	1085.2	32.2	0.029672	13.3	0.012256	119.4	0.110026	18.39	0.016946	52.65	0.048516
Banks Peninsula	1279.7	36.3	0.028366	15.41	0.012042	124.6	0.097367	19.5	0.015238	53.9	0.042119
Chatham Islands	1017	34.8	0.034218	16.3	0.016028	120.4	0.118387	21.3	0.020944	54.95	0.054031
Cook Strait	1045.3	35.9	0.034344	13.6	0.013011	120.5	0.115278	20.7	0.019803	51.5	0.049268
Northern	841.5	33.3	0.039572	12.86	0.015282	114.3	0.135829	17.63	0.020951	47.6	0.056566
Australia	1048	36.5	0.034828	13.4	0.012786	117.3	0.111927			48.1	0.045897

Excess primers and salts were removed from the PCR product by precipitation with isopropanol in the presence of 2.5M NH<sub>4</sub>Ac followed by a 70% ethanol wash. Purified PCR fragments were sequenced using BigDye Termination Mix (Perkin-Elmer) and run out on an ABI 373 automatic sequencer. Both the sense and antisense strands of 12S and cytb were sequenced while CR was sequenced in 1 direction only as a poly C region prevented successful sequencing using the LtrNA primer. Sequences were deposited in GenBank (<http://www.ncbi.nlm.nih>) (accession numbers AF468919-AF468956).

Sequences were aligned using Clustal W version 1.6 (Thompson *et al.* 1994), then confirmed manually using sequential pairwise comparisons. Analyses were conducted using PAUP\*4.0b6 (Swofford 2001). Parsimony was used with the following settings: HEURISTIC search algorithm, gaps treated

as missing characters, all characters equally weighted, and zero-length branches were collapsed. When several equally parsimonious trees were found, a 50% majority rule consensus tree was constructed to assess the information.

### Vocalisations

Recordings of blue penguin calls from individuals within the ranges of 4 of Kinsky & Falla's 6 subspecies were obtained from various sources (information available from the authors). Sonagrams of 10 braying calls (Waas 1990) from Cook Strait, Banks Peninsula, Otago, and Australian (Phillip Island) birds were generated using Avisoft software (Specht 2000). We measured the duration of: 1, the inhalation component and 2, the exhalation component as a percentage of the total call length; 3, the frequency of the inhalation at the loudest point; 4, the frequency of the 3rd fundamental of the exhalation

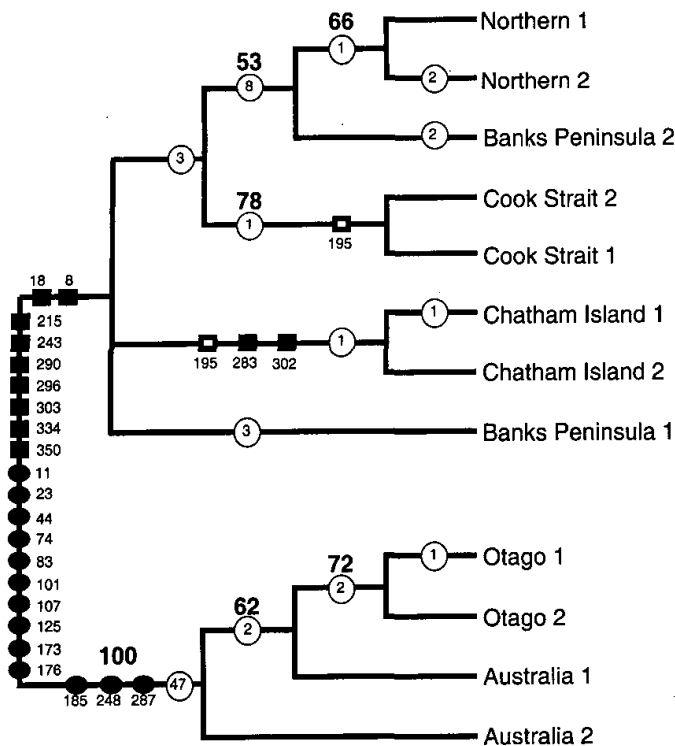

**Fig. 2** The 50% majority rule consensus tree from 3 equal-length trees resulting from maximum likelihood analysis of control region sequences from different populations of mtDNA of *Eudyptula minor*. Bold numbers above lines, bootstrap support greater than 50 (of 100 replicates); filled squares, substitutions in 12S sequences; filled circles, substitutions in cytb sequences; numbers next to squares and circles, position of the substitution in the sequence; open squares, the only homoplasious substitution in the 3 data sets; numbers within open circles, number of substitutions in control region sequences; numbers next to common names of taxa differentiate individuals sequenced.

at the loudest point; 5, the change in amplitude between inhalation and the 3rd fundamental of the exhalation; 6, minimum and maximum frequencies of the inhalation; 7, minimum and maximum frequencies of the 3rd fundamental of the exhalation. The variables were analysed using the discriminant function analysis of Systat 9.01 (SPSS Inc.) and known groups were used to generate linear models.

### Morphometrics

Morphometric data means (Table 2) from males and females were obtained from Kinsky & Falla (1976) and Marchant & Higgins (1990). We controlled for the effect of body size on the variables by dividing each variable by the mean body weight for individual males and females in each population. Measurements from Kinsky & Falla's (1976) Southland, Stewart Island, and Westland populations were excluded as we did not analyse the DNA of birds from these areas. Variables were standardised ( $\bar{x} =$

0, SD = 1) and morphological similarities were assessed using hierarchical clustering in the classification function of Systat 9.01 (1998 SPSS Inc.) using average linkage and Euclidean distance functions.

## RESULTS

### Genetics

Trees from all 3 mitochondrial regions shared a similar topology with 2 main clades (Fig. 2). The 1st clade consisted of Australian and Otago specimens and the 2nd included northern, Cook Strait, Chatham Island, and Banks Peninsula birds (hereafter referred to as the New Zealand clade) (Fig. 2). Within the New Zealand clade, the control region sequences provided some support for the Kinsky & Falla (1976) classification although the status of the Banks Peninsula population was unclear.

### Small ribosomal subunit (12S)

Parsimony analysis of the 12S data produced 2 equally parsimonious trees (treelength 12, consistency index (CI)=1.00, retention index (RI)=1.00) and both trees included 2 clades, the 1st clade contained Australian and Otago specimens and the 2nd clade contained blue penguins from the rest of New Zealand. Bootstrap analysis (Felsenstein 1984) showed good support for an Otago-Australian clade (100%), a Chatham Island clade (86%), and a Cook Strait-Chatham Island clade (60%). We found no differences in the 12S sequences between northern and Banks Peninsula birds (Appendix 1).

12S data were also analysed using maximum likelihood procedures. Modeltest version 3.06 (Posada & Crandall 1998) selected the Hasegawa-Kishino-Yano 1985 (HKY85) substitution model which produced a single best tree of score 544.50. The tree produced by maximum likelihood was consistent with the 2 parsimony trees.

All nucleotide substitutions in the 12S sequences were transitions, with 9 synapomorphic substitutions separating the Australia-Otago clade from the northern and Banks Peninsula clade. Overall, the 12S sequences of the Australia-Otago clade and the northern and Banks Peninsula clade differed by 2.6% (Appendix 1).

### Cytochrome oxidase *b* (cytb)

Parsimony analysis of the cytb sequences yielded 12 equally parsimonious trees (treelength 13, CI=1.00, RI=1.00). All of these trees supported the split between the Australia-Otago clade and the New Zealand clade. Bootstrap analysis supported the division between the 2 clades (100%). The 2 clades were separated by 9 synonymous transitions and differed by 4.0%. Sequences did not differ within the 2 clades.

Modeltest version 3.06 (Posada & Crandall 1998) selected the HKY85 substitution model for maximum likelihood analysis of the *cytb* sequences. Maximum likelihood found a single best tree with a score of 497.48. The tree produced by maximum likelihood was consistent with the parsimony tree and supported the division between the Australia-Otago clade and the New Zealand clade.

### Control region (CR)

Parsimony analysis of the control region sequences yielded 9 equally parsimonious trees (treelength 74, CI=0.83, RI=0.93). All of the most parsimonious trees supported the split between the Australia-Otago clade and the New Zealand clade. Within the New Zealand clade, all trees supported the monophyly of the Cook Strait specimens and the Chatham Island specimens. A 50% majority rule consensus found that, within the Australia-Otago group, 67% of the trees supported the monophyly of the Australian clade and 67% supported the monophyly of the Otago clade.

Using Modeltest version 3.06 (Posada & Crandall 1998), we selected the HKY85 plus  $\Gamma$  substitution model for maximum likelihood analysis of the control region sequences. Maximum likelihood analysis yielded 3 trees with a tree score of 900.14. All trees supported the division of blue penguins into the Australia-Otago clade and the New Zealand clade found in the 12S and *cytb* analyses. As with the parsimony analysis, maximum likelihood also strongly supported the monophyly of the Otago-Australian clade (100% of bootstrap replicates). Within the Australia-Otago clade 72% of bootstrap replicates supported monophyly of the Otago clade (Fig. 2).

Within the New Zealand clade, a maximum likelihood analysis of the control region sequences distinguished several subgroups, a Chatham Island clade, a Cook Strait clade, and a northern clade (Fig. 2). Consensus of the 3 maximum likelihood trees found from the control region sequences showed that all trees supported monophyly of the northern, Cook Strait, and Chatham Island clades. All 3 trees also supported the close relationship between northern and Cook Strait specimens. The status of the Banks Peninsula specimens was somewhat unclear as 1 specimen showed a close relationship with the Chatham Island specimens and the other showed a close relationship with the northern specimens (Fig. 2, Appendix 1). Within the New Zealand clade all substitutions were transitions.

The Otago control region sequences differed from the northern sequences by 11.8%. Differences between Otago and Northern sequences were 41 transitions, 8 transversions, and 1 insertion. The substitutions in the 12S and *cytb* sequences mapped exactly onto the CR maximum likelihood tree except for a substitution in position 195 of the Cook

Strait and Chatham Island 12S sequences (Fig. 2). The most parsimonious explanation for this change in the 12S sequences of Cook Strait and Chatham Island birds is that it may have been an instance of a reversion to the ancestral state. Other explanations are possible, however.

Consideration of 12S secondary structure models (Hickson *et al.* 1996) showed this substitution of an adenine to a guanine at position 195 in Chatham Island and Cook Strait specimens occurred in a stem which would be complementary to a cytosine at position 169. However, there are alternative models of 12S secondary structure which suggest this base pair is not within a conserved stem region and there is a non-complementary base pair in the same position in yellow-eyed penguins, *Megadyptes antipodes* (Paterson 1994).

### Vocalisations

The discriminant function analysis of the Cook Strait, Banks Peninsula, Otago, and Australian calls did not clearly separate the putative taxa. The Australian cluster was separated from the Banks Peninsula and Cook Strait clusters although the Otago cluster overlapped all 3 clusters. The discriminant function analysis also incorrectly classified 30% of calls. Of the 2 Australian calls classified incorrectly, 1 was assigned to Otago and 1 to the Cook Strait population. Five Otago calls were classified incorrectly, 2 to the Australia group and 3 to the Banks Peninsula group. Three Cook Strait calls were assigned incorrectly, 1 each to Australia, Otago, and Banks Peninsula. Two Banks Peninsula calls were classified incorrectly, 1 to Otago and 1 to Cook Strait.

The vocalisation results may have been confounded by small sample sizes and by pseudoreplication, as we could not always distinguish between individual penguins on the recordings. Where possible we used recordings made on different occasions or at different locations to lessen the risk of pseudoreplication. Also calls were recorded on a variety of recorders (e.g., reel to reel, cassette and digital audio tape) and variation in factors such as tape speed may have confounded our result.

We found further support for our genetic results from an examination of the inhalation component. Six of 10 Australian calls and 4 of 10 Otago calls shared a descending element on the end of their inhalation that was not seen in little blue penguin calls from Cook Strait and Banks Peninsula (Fig. 3).

### Morphology

The cluster analysis showed that, once the effect of body size was controlled, the Otago and Australian populations were morphologically similar to each other (Fig. 4). These are preliminary results, however, as the raw data used by Kinsky & Falla (1976) were unavailable.

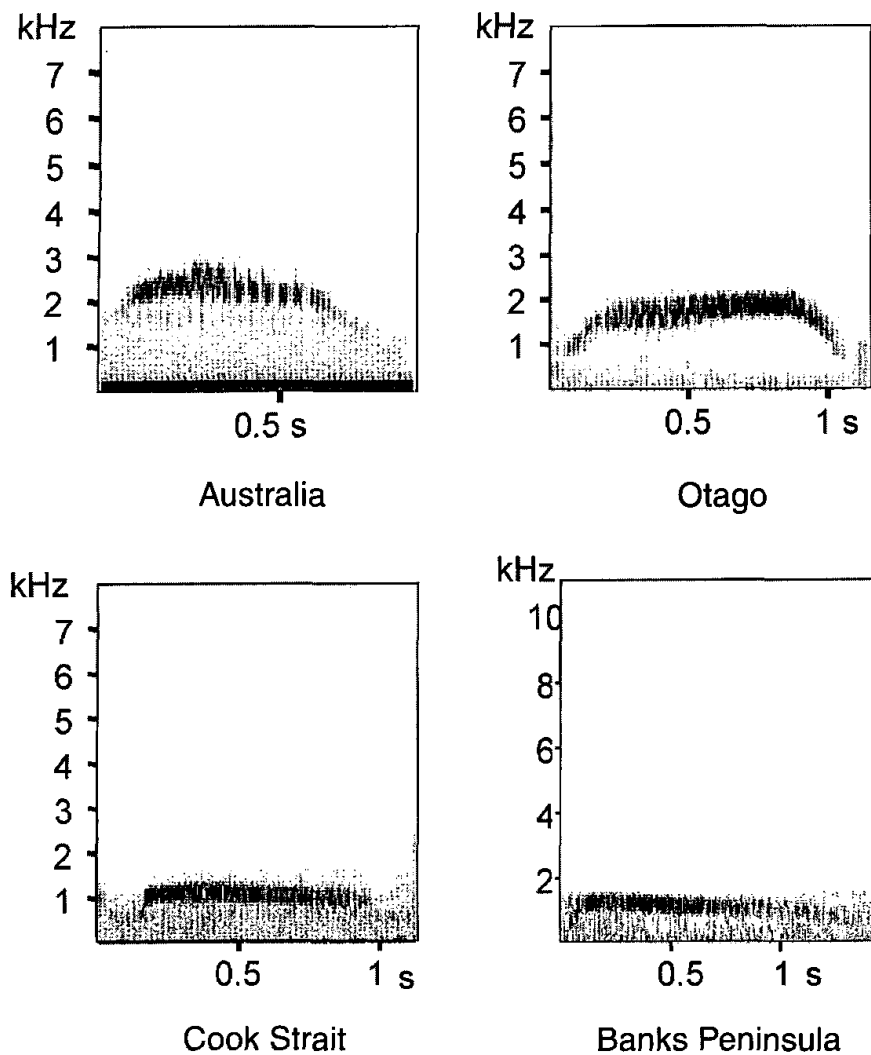

Fig. 3 Sonograms of inhaled component of Australian, Otago, Cook Strait and Banks Peninsula calls of *Eudyptula* penguins..

## DISCUSSION

The molecular results showed that the blue penguins could be subdivided into 2 clades, 1 made up of birds from the east coast of Australia and Otago, and the 2nd consisting of birds from northern North Island, Cook Strait, Chatham Islands, and Banks Peninsula. The close relationship between Australian and Otago birds was somewhat surprising, however a re-analysis of the means of the morphometric variables used to generate the subspecies classification showed that Australian and Otago birds were morphologically similar. A preliminary examination of the braying calls also showed some similarities between calls of Australian and Otago birds. Unlike the genetic analysis, the somewhat equivocal results from the vocalisation and morphometric analyses probably underline the difficulty other researchers have had in untangling the taxonomy of blue penguin using traditional taxonomic methods.

### Genetics

Results from 3 gene regions support 2 major monophyletic groups consisting of, respectively, Australian (Phillip Island) and Otago birds, and birds from

the rest of New Zealand. The 12S sequences of the Australia-Otago clade and the New Zealand clade differed by 2.5% which is greater than the level of divergence between royal penguins (*Eudyptes schlegeli*) and Fiordland-crested penguins (*E. pachyrhynchus*) (1.3%; GenBank accession numbers U88006 and X82522).

Within the New Zealand clade, the control region sequences showed some support for regional separation although the populations were not exceptionally distinct despite the control region's relatively high evolutionary rate in comparison to the 12S and *cytb* gene regions. The phylogenetic position of the Banks Peninsula penguins within the rest of New Zealand clade was also somewhat unclear, as noted 1 specimen showed affinities with the northern specimens whereas the other Banks Peninsula bird was most closely related to a Chatham Island bird. We advocate sequencing more birds from a range of localities to identify the level of variation in the control region within the various populations.

We do not believe that these results result from errors arising from mitochondrial sequences being transposed to the nucleus (examples in Zhang & Hewitt 1996) or by contamination because all the

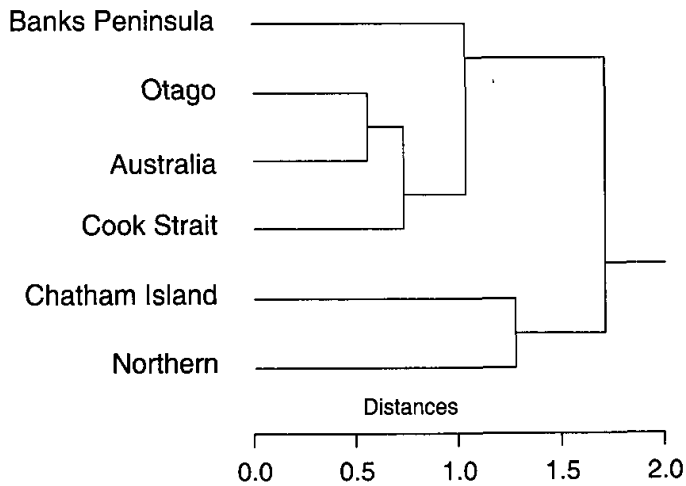

Fig. 4 Cluster analysis of mensural data from Kinsky & Falla (1976) and Marchant & Higgins (1990) (relative to body weight).

amplifications showed a single band, there were few ambiguous bases in the electropherograms, and the amino acid sequences translated from *cytb* were not punctuated by stop codons (12S sequences can not be translated directly because of secondary structure and the control region does not code for an amino acid sequence). We do not believe contamination has caused problems because extractions carried out in different labs yielded the same sequences as ours (Paterson *et al.* 1995; Paterson unpubl. data) and reactions carried out on different days produced the same results. These characteristics strongly suggest that our results were not caused by mitochondrial genes having been copied to the nucleus or by contamination.

### Vocalisations

The limited usefulness of the discriminant function analysis in distinguishing blue penguin populations may result from the variables chosen for analysis. However, a visual examination of the sonagrams showed some support for the genetic results. In both Australian and Otago populations, 50% of calls shared a descending element at the end of their inhalations (Fig. 3) that was not seen in the calls of Banks Peninsula and Cook Strait birds. We intend to obtain vocalisations of birds from the Chatham Island and northern populations and collect data on call characters such as syllable number and shape that may allow the differentiation of groups within *Eudyptula*.

### Morphology

The cluster analysis of the means of the morphometric data showed that Australian and Otago birds were morphometrically similar which supported our findings that the Australian and Otago populations were genetically closely related.

However, we did not have access to the raw data on which Kinsky & Falla (1976) based their classification of 6 blue penguin subspecies and therefore our morphometric analysis is only preliminary. Marchant & Higgins (1990) stated that bill measurements for *E. m. minor* in Kinsky & Falla (1976) are "obviously in error". In our cluster analysis we included, and excluded, the bill measurements adjusted for weight and both analyses produced a dendrogram showing morphological similarities between Otago and Australian birds, but the 2 dendrograms differed in the placement of the other taxa. Because Marchant & Higgins (1990) did not provide data to support their statement, we included the bill measurements in our analysis.

The measurements of the southern populations of blue penguin (Southland, Stewart Island, West Coast) differed markedly from those of the Otago population (Kinsky & Falla 1976). Despite the differences, Kinsky & Falla (1976) included the southern population with the Otago birds in the subspecies *E. m. minor*. Our cluster analysis of Kinsky & Falla's (1976) data showed that the Southland, Stewart Island, and West Coast birds were morphologically most similar to those from Cook Strait and the Chatham Islands, but we did not include the southern population in the morphometric results because we did not sequence mtDNA of birds from these areas.

### Evolutionary scenarios

There were 2 main results from our analysis of relationships within *Eudyptula*. The 1st was that there are 2 obvious clades within the genus *Eudyptula*, an Australia-Otago clade and 1 including birds from the rest of New Zealand. Assuming a rate of change of 2% million years<sup>-1</sup> in the 12S sequences (see Klicka & Zink 1997 for a review of the rates of change for 12S), the Australia-Otago group and the New Zealand clade diverged about 1.27 million years ago (mya). A rate of change of 1.58-2.86% million years<sup>-1</sup> estimated from studies of *cytb* sequences in species of albatross (Nunn *et al.* 1996), which are thought to be close relatives of the penguins (Sibley & Ahlquist 1990), would suggest that the 2 clades diverged 1.36-2.46 mya. Using the rate of 5% million years<sup>-1</sup> for the control region estimated from Galapagos finches (Freeland & Boag 1999), we calculated a divergence date of 2.38 mya for the 2 *Eudyptula* clades. Therefore estimates of the divergence date range from 1.27 to 2.46 mya. The relatively ancient divergence between the Australia-Otago group and the New Zealand group may have been associated with global cooling that started about 2.4 million years ago (Stevens *et al.* 1988). A possible mechanism linking the divergence of Australia and New Zealand populations and climatic cooling may be that once global cooling started, the

northern limit of *Eudyptula* distribution was shifted northwards allowing New Zealand birds to colonise Australia.

The close relationship between the Otago and Australian populations was unexpected. We offer 3 possible explanations for this close relationship. Our 1st hypothesis is that Australian populations may have established from Otago birds relatively recently (Fig. 5). We believe this explanation is unlikely because it would suggest the Otago population speciated sympatrically in New Zealand as there are presently no obvious barriers between the New Zealand populations. Additionally, the CR sequences indicated Otago birds were derived from Australian birds (Fig. 2).

Our 2nd hypothesis is that blue penguins originated in Australia, and New Zealand populations were established during 2 colonisation events, 1 relatively ancient and the other relatively recent (Fig. 5). We think this scenario is equally unlikely because it would require New Zealand to have been isolated from contact with Australia for millions of years despite being downstream of Australia in the prevailing ocean currents and downwind in the prevailing westerly winds.

Our 3rd, and favoured, hypothesis is that in the past blue penguins went extinct in the Otago region and the region was recolonised by birds of Australian origin (Fig. 5). We offer a possible mechanism and some circumstantial evidence for this hypothesis. Blue penguins straggle to the Snares Islands and, although there appears to be suitable nesting habitat on the islands (P. Sagar pers. comm.), breeding is unknown (Miskelly *et al.* 2001) which suggests that the Snares Islands may be beyond the southern limit of blue penguins. We envisage that during cold stages in the Pleistocene the southern limit of blue penguin distribution moved northwards, and during 1 stage the southern New Zealand blue penguins went extinct. Then, as temperatures rose in the following warm stage, the vacant habitat was filled by birds from Australia rather than birds of New Zealand origin. The prevailing wind and ocean currents would assist movement from Australia. The levels of genetic divergence between Australian and Otago birds suggest this may have occurred between 95 200 and 238 000 years ago.

The 2nd major finding of our study is that New Zealand populations including the Banks Peninsula birds, but excluding Otago birds, showed few differences in the mitochondrial 12S and cytb sequences. The New Zealand group did show some genetic differences in the control region which supported the subspecies classification of Kinsky & Falla (1976) although the taxonomic status of Banks Peninsula birds was unclear. Despite Banks Peninsula birds differing from other blue penguins in life

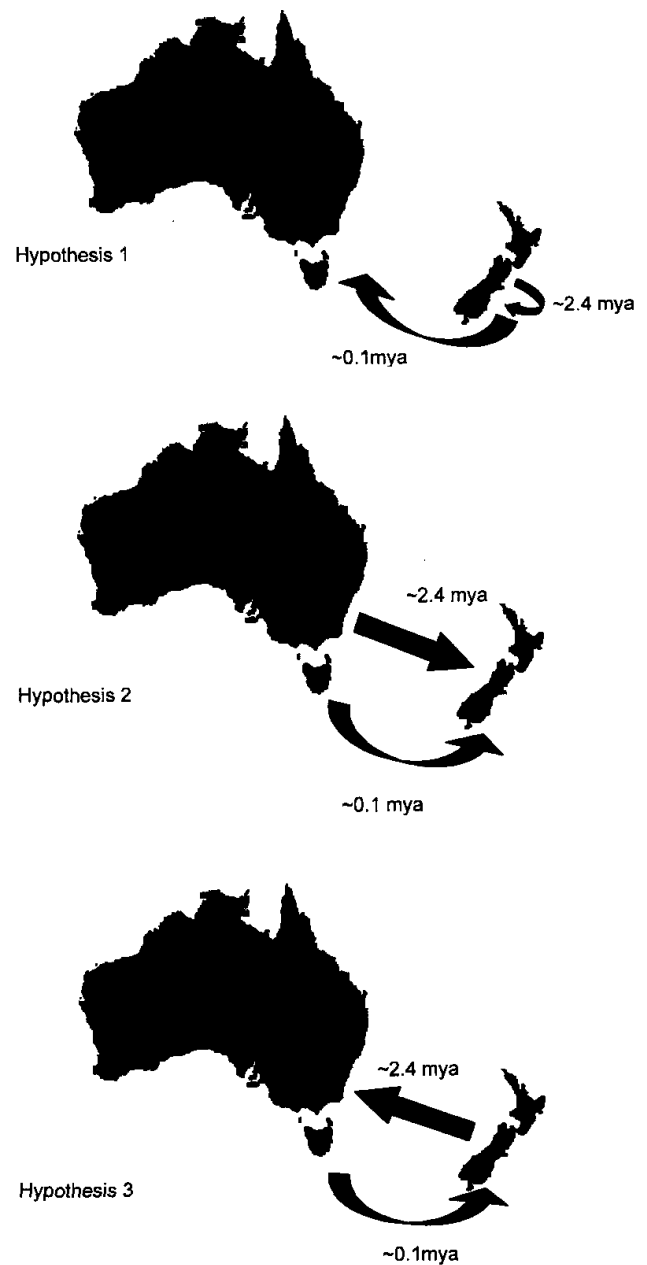

**Fig. 5** Colonisation hypotheses to explain genetic differences between New Zealand and Australian populations blue penguins (see text for details). Hypothesis 1, Otago penguins speciated sympatrically in New Zealand then colonised Australia; Hypothesis 2, New Zealand was colonised by 2 colonisation events, both events originating from Australia; Hypothesis 3, blue penguins colonised Australia from New Zealand and then colonised the Otago area after extinction of blue penguins in that area during the Pleistocene.

history and morphological traits (C. Challies, pers. comm.), their uncertain phylogenetic position may indicate gene flow between populations within the New Zealand clade. More extensive sampling of populations could resolve this uncertainty. We would also advocate sampling from little blue penguins from a wider range of areas to investigate the limits of the Otago population and to investigate the affinities of *E. minor* from Southland, Stewart



Island, and the West Coast. Sequencing of nuclear gene regions is also necessary to investigate whether nuclear gene flow reflects mitochondrial gene flow.

#### ACKNOWLEDGEMENTS

We thank all who helped with collecting specimens, especially Peter Dann and Roz Jessop, (Phillip Island, Australia), Mike Wakelin (Wellington), David Weatherly (Auckland Museum), and Sonja van Alphen (Christchurch); the McPherson Natural History Unit Sound Archive for recordings; Shinichi Nakagawa for assistance with the vocal analysis and Cor Vink for assistance with collecting and phylogenetic analysis. This work was funded by a Kelly Tarlton's Antarctica New Zealand scholarship and Lincoln University.

#### LITERATURE CITED

- Avise, J.C. 1994. *Molecular markers, natural history and evolution*. New York, Chapman & Hall.
- Dennis, A. 1999. Helping the penguins. *Forest & bird* 291: 36-39.
- Felsenstein, J. 1984. Distance methods for inferring phylogenies: an approach using the bootstrap. *Evolution* 39: 783-791.
- Freeland, J.R.; Boag, P.T. 1999. Phylogenetics of Darwin's finches: paraphyly in the tree finches, and two divergent lineages in the warbler finch. *Auk* 116: 577-588.
- Hickson, R.E.; Simon, C.; Cooper, A.; Spicer, G.S.; Sullivan, J.; Penny, D. 1996. Conserved sequence motifs, alignment, and secondary structure for the third domain of animal 12S rRNA. *Molecular biology and evolution* 13: 150-169.
- Hillis, D.; Mable, B.; Larson, A.; Davis, S.; Zimmer, E. 1996. *Nucleic acids IV: sequencing and cloning*. pp. 321-381 In: Hillis, D.; Moritz, C.; Mable, B. (ed.) *Molecular systematics*. Sunderland, Sinauer Associates.
- Kinsky, F.C. (Convener) 1970. *Annotated checklist of the birds of New Zealand, including the birds of the Ross Sea Dependency*. Wellington, Checklist Committee, Ornithological Society and A.H. & A.W. Reed.
- Kinsky, F.C.; Falla, R.A. 1976. A subspecific revision of the Australasian Blue Penguin (*Eudyptula minor*) in the New Zealand region. *National Museum of New Zealand records* 1: 105-126.
- Klicka, J.; Zink, R.M. 1997. The importance of recent ice ages in speciation: a failed paradigm. *Science* 277: 1666-1669.
- Marchant, S.; Higgins, P.J. 1990. *Handbook of Australian, New Zealand and Antarctic birds, Vol. 1. Ratites to ducks*. Oxford, Oxford University Press.
- Meredith, M.; Sin, F. 1988a. Genetic variation of four populations of the little blue penguin, *Eudyptula minor*. *Heredity* 60: 69-76.
- Meredith, M.; Sin, F. 1988b. Morphometrical analysis of four populations of the little blue penguin, *Eudyptula minor*. *Journal of natural history* 22: 801-809.
- Miskelly, C.M.; Sagar, P.M.; Tennyson, A.J.D.; Scofield, R.P. 2001. Birds of the Snares Islands, New Zealand. *Notornis* 48: 1-40.
- Nunn, G.B.; Cooper, J.; Jouventin, P.; Robertson, C.J.R.; Robertson, G.G. 1996. Evolutionary relationships among extant albatrosses (Procellariiformes: Diomedidae) established from complete cytochrome-B gene sequences. *Auk* 113: 784-801.
- Paterson, A.M. 1994. Coevolution of seabirds and feather lice. Unpubl. PhD thesis, University of Otago, Dunedin.
- Paterson, A.M.; Gray, R.D.; Wallis, G.P. 1995. Penguins, petrels and parsimony: does cladistic analysis of behavior reflect seabird phylogeny? *Evolution* 49: 974-989.
- Posada, D.; Crandall, K. A. 1998. Modeltest: testing the model of DNA substitution. *Bioinformatics* 14: 817-818.
- Ritchie, P. A. 2001. The evolution of the mitochondrial DNA control region in the Adelie penguins of Antarctica. Unpubl. PhD thesis, Massey University, Palmerston North.
- Sibley, C.G.; Ahlquist, J.E. 1990. *Phylogeny and classification of birds: a study in molecular evolution*. New Haven & London, Yale University Press.
- Simon, C.; Frati, F.; Beckenbach, A.; Crespi, B.; Liu, H.; Flook, P. 1994. Evolution, weighting and phylogenetic utility of mitochondrial gene sequences and a compilation of conserved polymerase chain reaction primers. *Annals of the Entomological Society of America* 87: 651-701.
- Specht, R. 2000. *Avisoft-SASLabPro*. Berlin, Specht, R.
- Stevens, G.; McGlone, M.; McCulloch, B. 1988. *Prehistoric New Zealand*. Auckland, Heinemann Reed.
- Sunnucks, P. 2000. Efficient genetic markers for population biology. *Trends in ecology and evolution* 15: 199-203.
- Swofford, D.L. 2001. *PAUP\*: Phylogenetic Analysis Using Parsimony (and other methods)*, Version 4.0b5. Sunderland, Sinauer Associates.
- Thompson, J.D.; Higgins, D.G.; Gibson, T.J. 1994. Clustal W: improving the sensitivity of progressive multiple sequence alignment through sequence weighting, positions-specific gap penalties and weight matrix choice. *Nucleic Acids Research* 22: 4673-4680.
- Turbott, E.G. 1990. *Checklist of the birds of New Zealand*. Auckland, Random Century.
- Waas, J. 1990. *An analysis of communication during the aggressive interactions of little blue penguins (Eudyptula minor)*. pp. 345-376 In: Davis, L.S.; Darby, J.T. (ed.) *Penguin biology*. San Diego, Academic Press.
- White, T.J.; Bruns, T.; Lee, S.; Taylor, J. 1990. *Amplification and direct sequencing of fungal ribosomal RNA genes for phylogenetics*. pp. 315-322 In: Innis, M.A.; Gelfand, H.; Sninsky, J.J.; White, T.J. (ed.) *PCR Protocols: A guide to methods and applications*. San Diego, Academic Press.
- Zhang, D.X.; Hewitt, G.M. 1996. Nuclear integrations: challenges for mitochondrial DNA markers. *Trends in ecology and evolution* 11: 247-251.

**Appendix 1** Pairwise distances between 12S sequences using HKY85 model parameters below the diagonal and pairwise distances between CR sequences using HKY 85 plus  $\Gamma$  model parameters above the diagonal.

	1	2	3	4	5	6	7	8	9	10	11	12
1 Northern 1	-	0.00488	0.02865	0.02865	0.03442	0.03152	0.03736	0.00986	0.16462	0.16980	0.17109	0.17091
2 Northern 2	0.00000	-	0.03164	0.03164	0.03753	0.03455	0.04053	0.01251	0.16519	0.17038	0.17167	0.17149
3 Cook Strait 1	0.00284	0.00284	-	0.00000	0.01502	0.01242	0.01766	0.02865	0.17478	0.18016	0.18154	0.18135
4 Cook Strait 2	0.00284	0.00284	0.00000	-	0.01502	0.01242	0.01766	0.02865	0.17478	0.18016	0.18154	0.18135
5 Chatham Is.1	0.00857	0.00857	0.00570	0.00570	-	0.00241	0.01242	0.03441	0.17492	0.18030	0.18169	0.17092
6 Chatham Is. 2	0.00863	0.00863	0.00576	0.00576	0.00000	-	0.00986	0.03151	0.16968	0.17496	0.17629	0.16574
7 Banks Peninsula 1	0.00000	0.00000	0.00284	0.00284	0.00857	0.00863	-	0.03736	0.18025	0.18575	0.18719	0.17620
8 Banks Peninsula 2	0.00000	0.00000	0.00296	0.00296	0.00878	0.00883	0.00000	-	0.16476	0.16994	0.17122	0.17104
9 Otago 1	0.02625	0.02625	0.02925	0.02919	0.0352	0.03537	0.02619	0.02069	-	0.00241	0.00730	0.01234
10 Otago 2	0.02625	0.02625	0.02925	0.02919	0.03525	0.03537	0.02619	0.02069	0.00000	-	0.00483	0.00980
11 Australia 1	0.02625	0.02625	0.02925	0.02919	0.03525	0.03537	0.02619	0.02069	0.00000	0.00000	-	0.00486
12 Australia 2	0.02625	0.02625	0.02925	0.02919	0.03525	0.03537	0.02619	0.02069	0.00000	0.00000	0.00000	-