

THRUST CONTROL OF VTOL AIRCRAFT – PART DEUX

DANIEL C. DUGAN

daniel.c.dugan@nasa.gov

Aero Engineer/Research Pilot †‡

NASA Ames Research Center

Moffett Field, California

ABSTRACT

Thrust control of Vertical Takeoff and Landing (VTOL) aircraft has always been a debatable issue. In most cases, it comes down to the fundamental question of throttle versus collective. Some aircraft used throttle(s), with a fore and aft longitudinal motion, some had collectives, some have used Thrust Levers where the protocol is still “Up is Up and Down is Down,” and some have incorporated both throttles and collectives when designers did not want to deal with the Human Factors issues. There have even been combinations of throttles that incorporated an arc that have been met with varying degrees of success. A previous review was made of nineteen designs without attempting to judge the merits of the controller. Included in this paper are twelve designs entered in competition for the 1961 Tri-Service VTOL transport. Entries were from a Bell/Lockheed tiltduct, a North American tiltwing, a Vanguard liftfan, and even a Sikorsky tiltwing. Additional designs were submitted from Boeing Wichita (direct lift), Ling-Temco-Vought with its XC-142 tiltwing, Boeing Vertol’s tiltwing, McDonnell’s compound and tiltwing, and the Douglas turboduct and turboprop designs. A private party submitted a re-design of the Breguet 941 as a VTOL transport. It is important to document these 53 year-old designs to preserve a part of this country’s aviation heritage.

INTRODUCTION

During the design phase of an aircraft, the control of thrust should be a straightforward process. If the aircraft is to be an airplane, throttle(s) would be the logical choice – forward for increased thrust and aft to reduce thrust. This holds true for jets or piston powered aircraft with some variations in the throttle design. Most use a conventional, vertically oriented throttle(s) on a quadrant to be operated by the pilot’s right or left hand. Many Cessnas, however, use a push-pull rod with a knob to grip it and it is moved forward into the instrument console for increased power and aft to reduce power.

Vertical Takeoff and Landing (VTOL) aircraft, including helicopters, often use a conventional collective “stick” or Power Lever – or throttles of various designs. The convention “Up is Up and Down is Down” has served the VTOL community well for many decades. There have also been successful designs that use a type of throttle where “Forward is Up and Aft is Down.” All seem to work relatively well. One notable and unsuccessful adaption was found in the MV-22 Osprey. The original collective design was replaced before the early Full Scale Development (FSD) models were built. In this case, “Forward and Down was Up,” and “Up and Aft was Down.” Many thought that this was a recipe for disaster and they were proven correct. In one emergency situation, control of an MV-22 was lost during its first flight due to a lateral control out-of-phase condition. The instinctive reaction of the pilot caused him to abruptly move the Thrust Control Lever (TCL) the wrong way, which resulted in the loss of the aircraft after he had

Presented at the Fifth Decennial AHS Aeromechanics Specialists’ Conference, San Francisco, CA, January 22-24, 2014. This is a work of the U. S. Government and is not subject to copyright protection in the U.S.

managed to put it safely on the ground for an instant. After that mishap, a long and expensive redesign was undertaken which resulted in a pure forward and aft longitudinal movement of the TCL with no arc.

Some designers of past VTOL aircraft did not want to deal with the Human Factors issues so they included both throttles and a collective control. Others designed unique controllers, but the convention was always Up and Down or Forward and Aft. Various schemes were sometimes used to “gang” the throttles together and even operate them as a type of collective until the forward flight or airplane mode was reached.

The designs presented in this follow-on paper include many widely varying types. From the military’s “flying platform” concepts, which were actually flown, to designs that never left the drawing boards. None were ever truly successful and adapted by the Armed Services, but a lot of Research and Development dollars were expended. In the previous paper, only two concepts discussed were successful – vectored thrust as embodied in the Harrier series, and the MV-22 tiltrotor. The tiltwings, tiltducts, and others were discarded. Some of these were evaluated in flight and the rest faded into obscurity.

This paper will also present some heretofore little known designs from the Tri-Service VTOL Transport competition from 1961. There were many “players” in this competition, but the only entry built was the Ling-Temco-Vought XC-142. Five prototypes were manufactured and all but one came to an untimely end. It resides in the USAF Museum at Wright-Patterson AFB, Dayton, Ohio.

FLYING PLATFORMS

In the fifties and sixties, the U.S. Army pursued the development of “Flying Platforms.” The Navy, Air Force, and NASA were also interested in the concept and contributed funding for some of the research. The ducted propeller was often used to augment lift. Many were flown and tested but none proved practical and they were either scrapped or sent to museums. In some cases, it was difficult to determine the thrust controller, but a motorcycle type twist grip throttle was often used.

VZ-1E “Pawnee”

The Hiller VZ-1E was the third variant of this ducted fan platform and it used a conventional helicopter collective pitch lever. Two earlier variants used a twist grip throttle (Figure 1) The first variant, the VZ-1 (Figure 2), was funded by the Office of Naval Research (ONR) and was powered by two 40 hp engines. A 5 ft diameter duct enclosed two contra-rotating rotors. No cross shafting was included in the design. This was unsafe and unacceptable because each rotor was driven by one of the engines. The second Pawnee had a duct diameter of 8 ft, three 40 hp engines, and a deeper duct

for increased lift. In both of these prototypes, the pilot stood upright while controlling the platform. There was a cross shaft included in this design. In the final configuration, the VZ-1E (Figure 3), the duct was deeper still and the pilot was seated and used conventional helicopter controls. The first two variants were kinesthetically controlled by the pilot by leaning in the desired direction of flight. The VZ-1E, however, had vanes in the duct to permit control of the flight path.

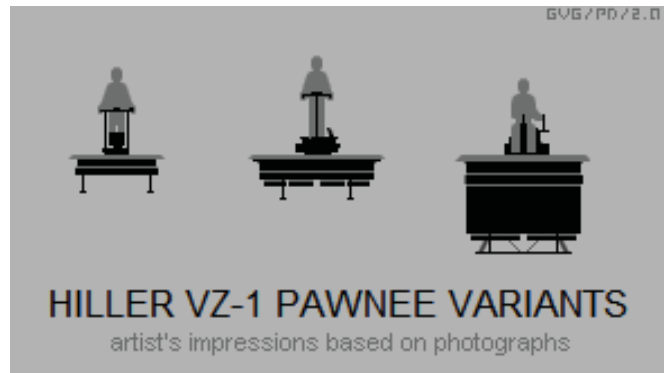

Figure 1. Hiller Pawnee Variants



Figure 2. The Hiller VZ-1



Figure 3. The Hiller VZ-1E

De Lackner Aerocycle

A National Advisory Committee for Aeronautics (NACA) engineer, Charles Zimmerman, proposed that the rotors of a VTOL aircraft be located on the underside of the air vehicle. Kinesthetic control was proposed for aircraft control. The U.S. Army ordered a number of the DeLackner DFH-4 Helivector or later known as the Aerocycle (Figure 4). As one might expect, this configuration could be hazardous to the pilot with two rotors spinning in opposite directions just under his feet. The rotors also kicked up ground debris and dust during takeoffs, landings, and hovering flight. The pilot was held in place by a safety belt and his grip on the motorcycle type thrust control on the handlebars. This grip controlled RPM only since the rotors were fixed pitch. A 40 hp outboard motor powered the platform and the landing gear initially consisted of airbags replaced by skids later in the program.

There were two accidents early in the program. Fortunately no one was injured but the project was eventually cancelled.



Figure 4. The De Lackner Aerocycle

UNIQUE VTOL AIRCRAFT

A number of unusual and innovative VTOL aircraft were studied to document the type of thrust control used in their design and operation.

Ryan VZ-3 “Vertiplane”

This was a one-of-a-kind aircraft built for the U.S. Army in the mid-fifties with its first flight in 1959 (Figure 5). It was an unusual configuration with very large flaps and end plates to capture the propellers slipstream and augment lift. The aircraft was powered by a Lycoming turboshaft engine that produced 1000 hp. The concept was to allow flight from hover to low forward speeds, however neither hover nor vertical takeoff were ever achieved. It required some forward speed to make every short takeoff

Differential prop pitch was used for roll control while pitch and yaw control was provided by the engine exhaust at the tail until the aerodynamic controls became effective with forward speed. A throttle was used for thrust control. The aircraft was located at Ames Research Center in the early sixties. During one “unplanned” maneuver, the pilot ejected over the Bay’s salt ponds and the aircraft crashed. The pilot survived with back injuries and the aircraft was rebuilt and resumed flying in 1961. An earlier accident had occurred in 1959.



Figure 5. The Ryan VZ-3

Doak VZ-4 (Model 16)

This was another one-of-a-kind aircraft with two tilting ducts (Figure 6).



Figure 6. The Doak VZ-4 (Doak Model 16)

The aircraft had a two place, tandem cockpit, although it was always flown with a single pilot. The VZ-4 was powered by a Lycoming T-53-L-1 turboshaft engine rated at either 824 or 840 hp – later in the program, a 1000 hp engine was installed. Various components from other aircraft included landing gear from a Cessna 182, seats from a P-51, and duct actuators from the T-33 flap motors. Its estimated maximum speed of 229 mph was demonstrated during the flight test program.

The wing tip ducts were five feet in diameter with an inside diameter of four feet. A vane in the tail used engine exhaust to provide pitch and yaw control during hovering flight. Conventional flight controls were used in airplane mode flight. Testing began in February 1958 at Torrance, CA and the project was transferred to Edwards Air Force Base in

October 1958 where it remained until the Army moved it to Langley Research Center, VA. The Doak remained at Langley until August 1972 (1).

The search for the type of thrust control used was long and frustrating. The aircraft is on display at the Ft. Eustis, VA Transportation Museum; however, the contents of the entire cockpit had been removed and references to the aircraft did not include the thrust controller. Finally, a grainy, black and white photo surfaced that showed an early, tethered hover flight before the aircraft skin was installed. There it was – the pilot with his left hand on a collective lever (Figure 7).

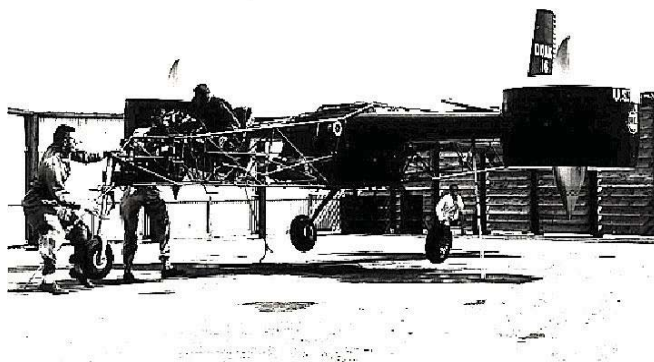

Figure 7. “Skinless” Doak VZ-4

Boeing VZ-2A (Model 76)

This aircraft was designed for an early look into tilt-wing technology. It was an odd bird which initially had a tubular airframe with no skin but the airframe was later covered (Figure 8). It was built by Boeing Vertol in 1957 and it was funded by the U.S. Army and the Office of Naval Research (ONR). The VZ-2 was powered by a Lycoming YT-53-L-1 engine of almost 700 hp. That engine, however, was the forerunner of T-53 engines producing 1400 hp. It had two ducted fans: one located in the horizontal stabilizer (pitch control) and one in the vertical fin for yaw control. The pilot and copilot sat side by side.



Figure 8. Boeing VZ-2A (Model 76)

The prop-rotors were 9.5 ft in diameter, and the VZ-2 had a maximum airspeed of approximately 134 mph. It was first flown in the late nineteen fifties and the first transition from the vertical mode to the airplane mode took place in April 1957. Thrust control was managed by a collective controller (Figure 9). The aircraft was turned over to NASA and it continued to fly until 1965. It is now residing in the Garber Facility of the Smithsonian.



Figure 9. VZ-2A Cockpit

VZ-5 (Fairchild 224)

This was another rare and unusual configuration that used the deflected slipstream from the four propellers mounted on the wing to augment lift – similar to the concept employed in the VZ-3 (Figure 9). It was also known as The Fledgling. The power plant was a GE YT-58 turboshaft engine providing power for four 3-bladed propellers mounted just below the wing. The VZ-5 had two 4-bladed tail rotors mounted above the horizontal stabilizer for pitch control (Figure 9). A throttle was used for thrust control. This concept demonstrator was built for the U.S. Army and had its first tethered flight in November, 1959. The VZ-5 never proceeded past tethered flight and the aircraft project was terminated.



Figure 10. VZ-5 (Fairchild M-224-1)

Bell ATV (Aircraft Test Vehicle) – Model 65

The ATV was still another one-of-a-kind, VTOL aircraft manufactured by Bell. It used available parts from many aircraft – a Schweizer sailplane fuselage, a Cessna 170 wing, and a set of skids from the Model 47 helicopter. The decision was made to use tilting jet pods with Fairchild J-44 engines (Figure 11). A separate Continental-Turbomeca Palouste gas turbine provided the thrust for the reaction control system used in vertical flight. It had two sets of controls – one for the vertical mode and conventional controls for airplane mode flight. Wingtip exhaust ducts provided roll control and pitch and yaw control were derived from exhaust ducts on the tail. Its first flight was made in January 1954 on a tether. The ATV was damaged the next month from an engine failure and subsequent fire. After repairs, flight tests resumed, but the program was terminated in early 1955 after only 4.5 flight hours. The ATV was to be followed by the successful X-14 or Model 68. After investigation by a Smithsonian historian, it was determined that the ATV thrust control was provided by a collective controller (Figure 12).



Figure 11 Bell ATV (Model 65)

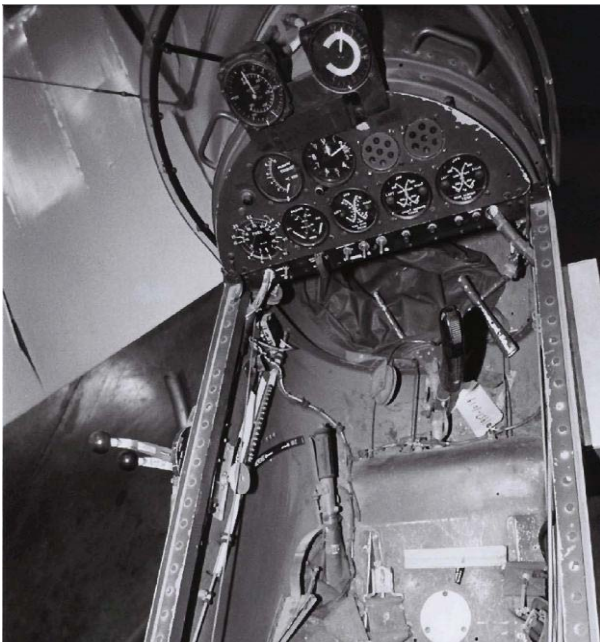

Figure 12. ATV Cockpit

Hiller X-18 Tilt-Wing

The Hiller X-18 was designed in 1955 and was subsequently funded by the USAF. Once again, in order to hold costs down, parts from other aircraft were utilized. The fuselage was from the YC-122C Avitruc, and the props from the Lockheed XFV-1 and Convair XFY-1 "Pogo" fighters. The large contra-rotating props were 16 feet in diameter and the engines had no cross shaft, therefore a single engine failure would be catastrophic (Figure 13). Testing proceeded, and 20 flights were conducted at Edwards AFB, CA. The last flight on July 1961, almost resulted in the loss of the aircraft after it entered a spin at 10,000 ft while hovering flight was attempted.

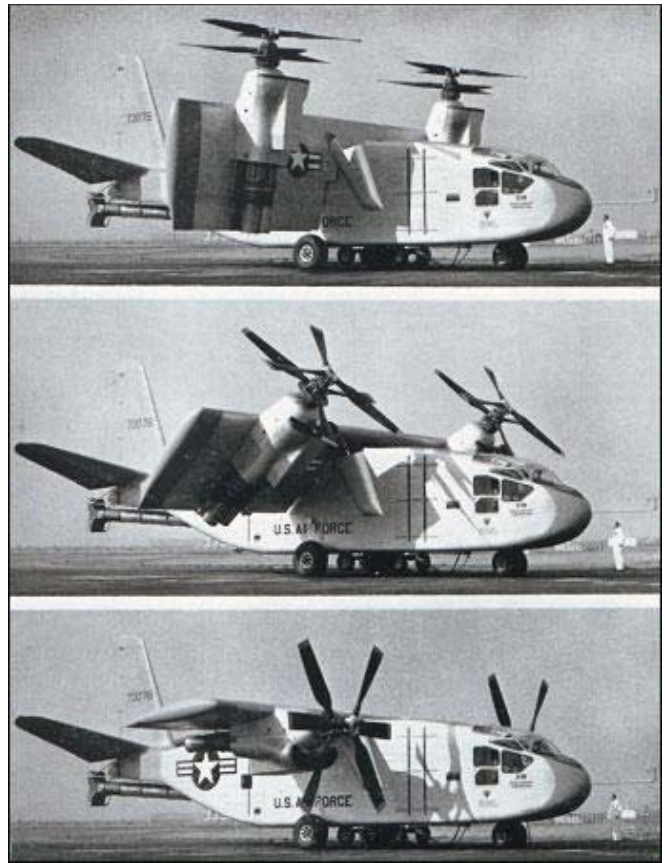

Figure 13. Hiller X-18 (Propelloplane)

Throttles were used for the X-18 for thrust control in its conventional transport aircraft cockpit.

Curtiss Wright X-100

The chief aerodynamicist for Curtiss-Wright, Henry Borst, proposed this VTOL aircraft that would benefit from the "radial force" principle. The rotating disk would provide an additional lift component as the propeller disk was inclined from the horizontal to the vertical. He believed that short propellers with wide chords would magnify this effect and have an advantage over tiltrotor designs such as the XV-3. Construction began in early 1958 and the result was an "ungainly" two place aircraft with a fabric-covered fuselage. The X-100 began tethered hover tests in April 1959 and in March 1960, the first rolling takeoff was made. The first and only complete conversion to near airplane mode of flight was made in April of 1960. In October 1960, the X-100 was transferred to NASA's Langley Research Center where it flew only in the vertical mode. In October 1961, an accident causing moderate damage ended its flight test program. A total of only 14 hours of flight time had been accumulated.

The X-100 was powered by a Lycoming YT-53-L-1 engine that produced 825 shp. The prop diameter was 10 ft and maximum gross weight was 3,729 lb (Figure 14).



Figure 14. Curtiss-Wright X-100

With fixed landing gear and a T-tail, the nacelles pivoted to within 12 degrees of the horizontal. In hovering and low speed flight, engine exhaust was ducted through a device named a “Jetivator” located at the rear of the fuselage. Vents controlled both pitch and yaw forces.

Thrust control of the X-100 was by the use of a throttle like the ill-fated X-19 to be produced in 1963. It had propellers that were similar in design to those of the X-100.

Fairey Rotodyne

The large Fairey Rotodyne was an unusual combination of helicopter, autogyro, and fixed wing turboprop. It went through various stages of development and design in the 1950s and the project was canceled in 1962 when British government funding dried up. The military had been interested in the concept and some civil orders were even considered. The Rotodyne had four rotor tip jets driven by fuel and bleed air from the engines and two turboprop engines mounted under the wings (Figure 15). After a takeoff using the 90 feet in diameter rotor system, engine power was diverted to drive the props. In this mode, the rotor was auto-rotated or free-wheeled at reduced collective pitch to reduce drag. A combination of collective pitch lever was used primarily for VTOL operation in the last design while throttles were used in forward flight.



Figure 15. Fairey Rotodyne

The aircraft was to be used for short to medium haul city-to-city transport of approximately 48 passengers. Noise from the tip jets was a problem although modifications to mitigate that were planned. One prototype did reach a speed of 191 mph and the aircraft was designed to hover on a single engine.

VTOL TRANSPORT DESIGNS OF 1961

A Tri-Service competition to build a VTOL transport was put out for bids by the Army, Navy, and Air Force with entries to be submitted in 1961. Nine entries were submitted by individual companies and teams - Bell-Lockheed, North American, Sikorsky, Vanguard, Boeing-Wichita, Ling-Temco-Vought (LTV), Boeing-Vertol, McDonnell (2 entries), and Douglas (2 entries) all participated. Designs included tilt-wings, tilt-props, tilt-ducts, and even a lift fan. Of these myriad designs, one was selected: the LTV XC-142 tilt-wing. Five of these were built and one survived to be sent to the USAF Museum in Dayton, OH.

Douglas Models D-828 and D-829

Douglas proposed both a tilting, ducted fan entry and a tilting turboprop (Figures 16 and 17).

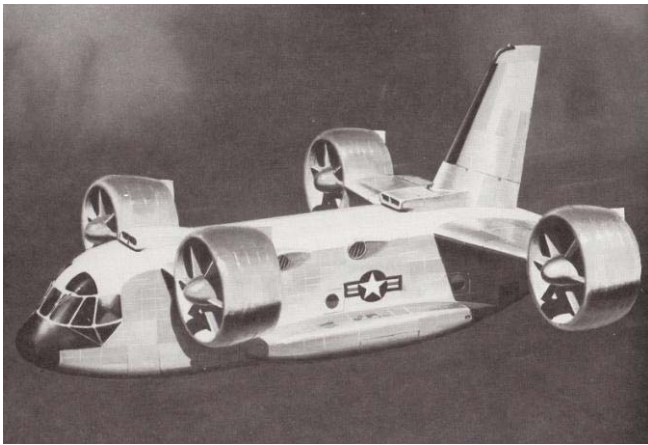

Figure 16. Douglas Model D-828

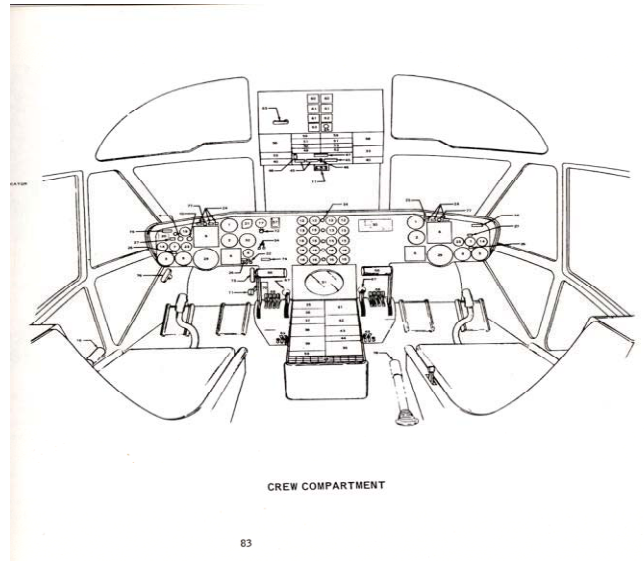

Figure 18. Douglas Models D-828/829 Cockpit



Figure 17. Douglas Model D-829

These two VTOL transport designs had many identical components, including the fuselage and vertical fin. The cockpit design and layouts were the same (Figure 18) and both throttles and collective controls were used for thrust control. Four T-64 engines drove the four, ducted fans and the aircraft was predicted to fly at 250 knots.

Sikorsky Tiltwing

Sikorsky's entry was a tiltwing with two T-64 turboprop engines driving large, 24 ft diameter propellers (Figure 19).



Figure 19. Sikorsky Tiltwing

It was designed to cruise at 233 knots at its mission gross weight of 35,000 lb at sea level. At lighter gross weights, maximum speed was forecast to be 352 knots. It had a unique "Height Control Lever" that controlled propeller pitch in its forward range in the helicopter mode of flight. It was oriented vertically like a throttle (Figure 20). Separate engine control levers place the engines in the governing range for airplane mode flight.

IV (b) COCKPIT

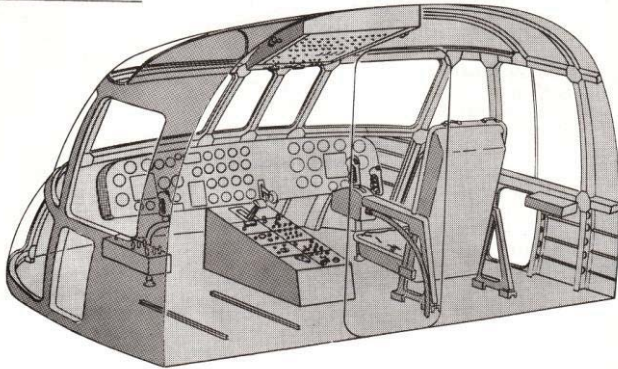

Figure 20. Sikorsky Tiltwing Cockpit

North American Tiltwing

This entry looked similar in some ways to the LTV XC-142, however, it was a unique design. T-64 engines drive 16 ft fiberglass propellers. A ducted fan mounted horizontally in the tail provided pitch control in the helicopter mode of flight (Figure 21).

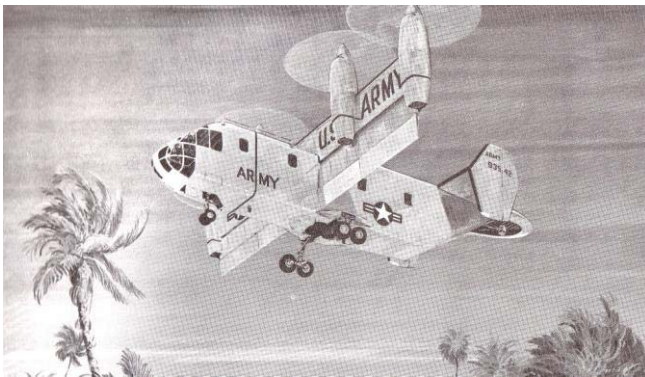

Figure 21. North American Tiltwing

Thrust control was provided by an unusual throttle arrangement. For airplane mode flight, they are used conventionally. In the VTOL modes, however, the inboard throttles were preset forward while the outboard throttles were moved forward to apply collective pitch to the propeller blades. The handles in these two outboard throttles could be folded upwards to form a vertical control for their simultaneous movement (Figure 22).

NORTH AMERICAN AVIATION, INC.
COLUMBUS DIVISION
COLUMBUS 14, OHIO

NA 61H-119

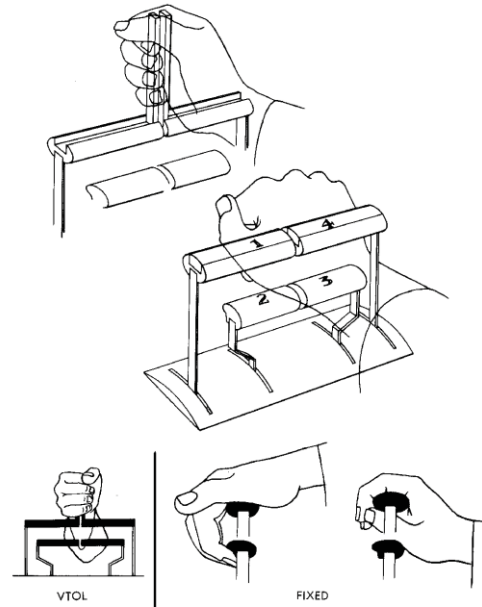

Figure 11 Throttle Design Concept
- 17 -

Figure 22. North American's Throttle Arrangement

Bell/Lockheed Model D2064

This ungainly entry was similar in appearance to the Douglas Model D-828 previously depicted. Four tilting ducts were driven by four T-64 engines and the four blade propellers were 8.6 ft in diameter (Figure 23).



MODEL NO. D 2064

Figure 23. Bell/Lockheed Model D2064

A maximum speed of 385 knots True Airspeed (TAS) was estimated at approximately 15,000 ft with an 8000 lb payload. Thrust control was managed by four throttles that could be ganged together for ease of operation (Figure 24).

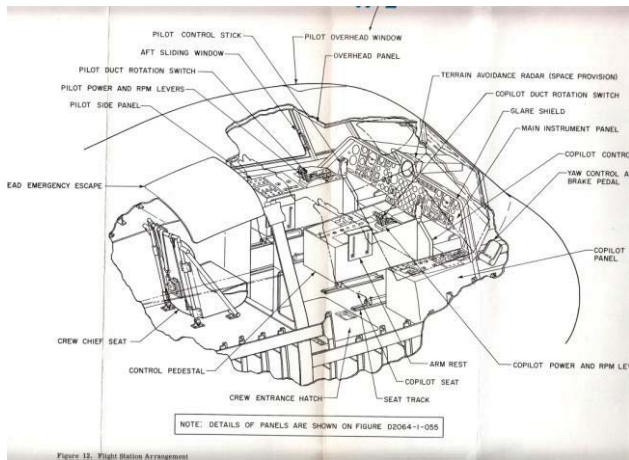

Figure 24. Bell/Lockheed Model 2064 Cockpit

McDonnell Compound Model 177

The Model 177 was the only compound design submitted for this competition. It was to be powered by two T-64 engines that were used in most of the entries. For airplane mode flight, there were two, 11 ft diameter, fixed pitch propellers that were to provide sufficient thrust for the Model 177 to reach a maximum of 237 knots – which was less than specification.

The main rotor system had three blades and a rotor diameter of 65 ft. The blades were driven by tip jets that eliminated the need for any anti-torque control (Figure 25).

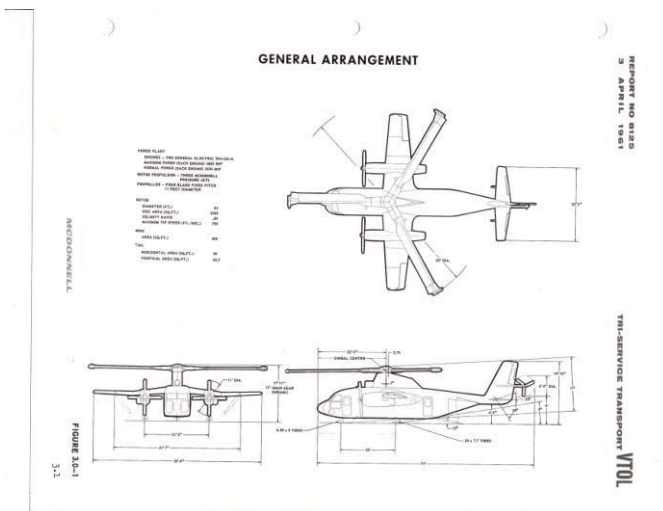

Figure 25, Model 177 Compound

A collective was used for thrust control in this design.

McDonnell also entered a tiltwing Model 175 in the competition. It had large, four blade, wide chord propellers with a diameter of 21 feet.. They were of fiberglass

construction. Two vertical tails were designed to provide adequate directional control and reduce the size of a single tail configuration. A 9 ft, horizontal tail rotor was located behind the empennage for pitch control. Cruise speed was estimated to be 259 knots with a maximum speed of 340 knots at military power (Figure 26).

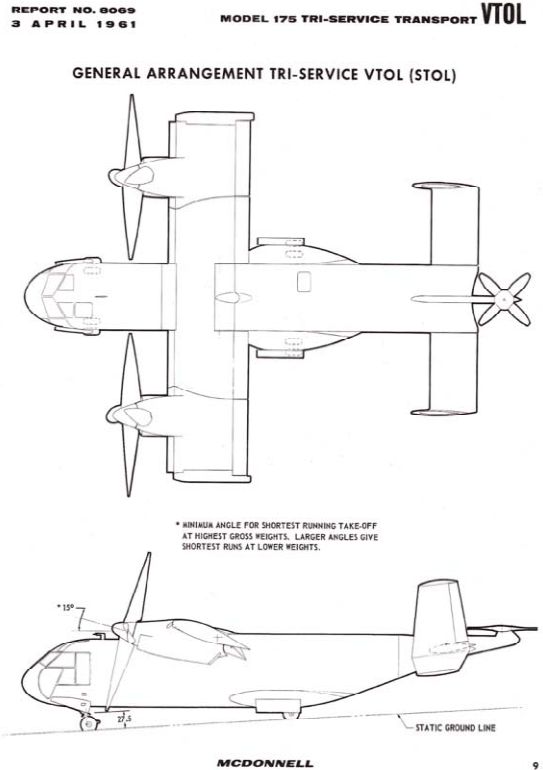
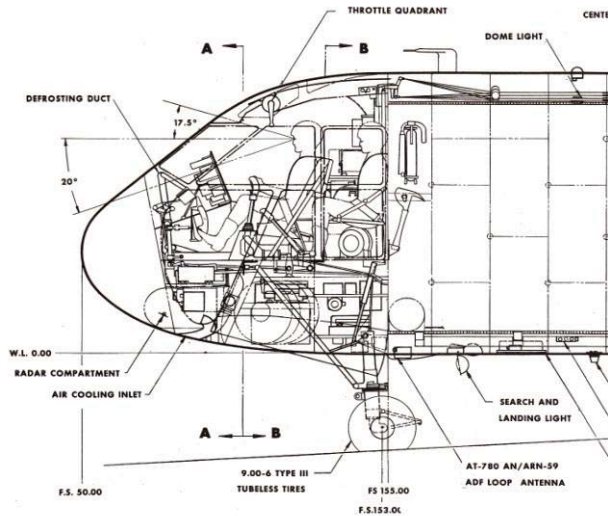

Figure 26. McDonnell Model 175

A collective “stick” was also used in this design with throttles for airplane mode flight (Figure 27).



MCDONNELL

Figure 27. Model 175 Cockpit Controls

Boeing-Vertol Model 137 Tiltwing

Building on experience and data derived from the Boeing-Vertol-Model 76 (VZ-2), the design of the Model 137 was entered into the Tri-Service competition for a 35,000 lb VTOL transport with a 4-ton payload. It had four T-64 engines podded in pairs below the wing. Two 3-bladed propellers were interconnected with a cross shaft for single engine safety. Pitch control in hover was provided by longitudinal cyclic control of the propellers. This negated the need for a propeller or other thrusting mechanism in the tail for pitch control. The wings incorporated leading edge slats and double slotted flaps for lift augmentation during conversion and steep descents (Figure28).

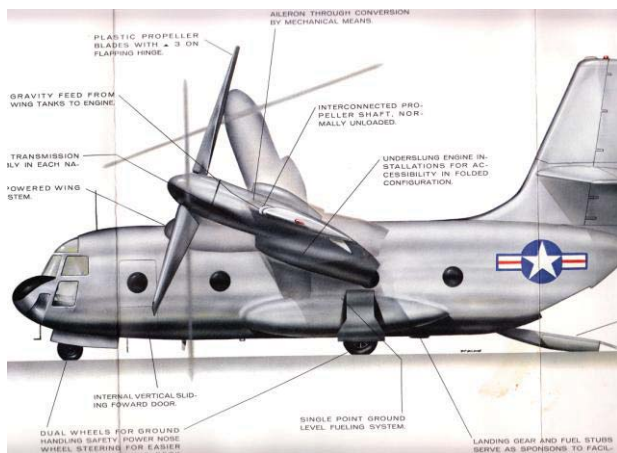

Figure 28. Boeing-Vertol Model 137 Tiltwing

A collective pitch controller was used for thrust control in the hover and conversion modes of flight while throttles were used conventionally in the airplane mode (Figure 29).

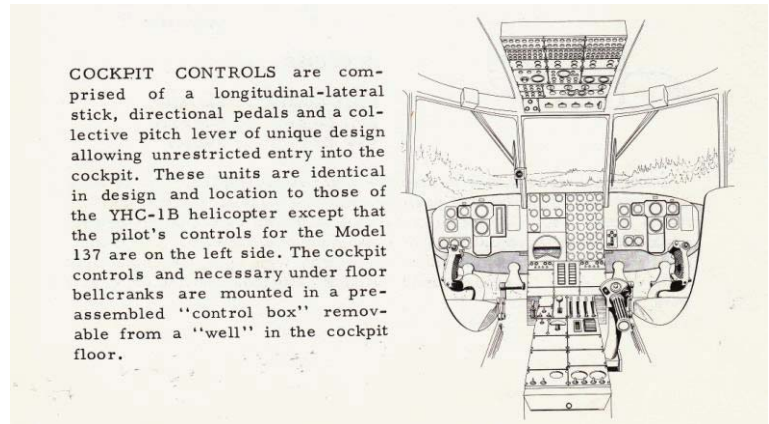

Figure 29. Model 137 Tiltwing Cockpit.

The Boeing-Wichita Model 900

This was a unique entry in the competition and it featured 12 LE 4000 lift engines imbedded in streamlined nacelles along each side of the fuselage, and two, GE CF700 turbofan cruise engines for airplane mode flight (Figure 30).

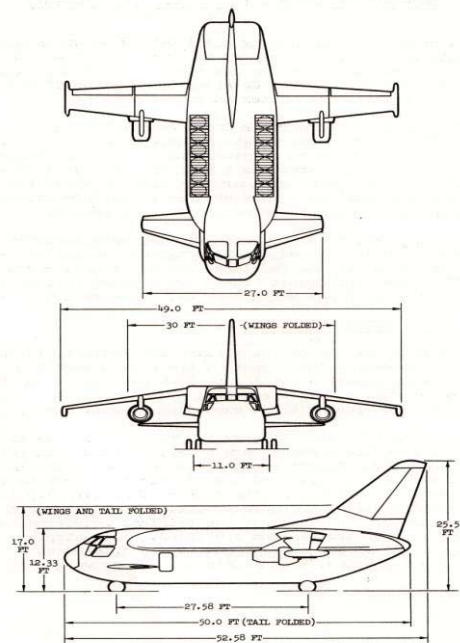

Figure 30. Boeing-Wichita Model 900

Prominent canards were designed to reduce the size of the aft wing and eliminate the need for a horizontal tail.

Powered by turbofan engines, the Model 900 had an estimated 360 kt speed at sea level at its design gross weight of 35,000 lb. The ferry range was predicted to be 2200 nm and it could still hover at an overload gross weight of 43,600 lb on a sea level standard day.

The numbers were impressive, but in the author’s opinion, overly optimistic. The Model 900 did utilize a collective-type thrust control referred to as a “height control lever.” The levers also served to provide thrust control of the cruise engines in airplane mode flight.

Vanguard Model 30 Lift Fan

The Vanguard Model 30 was to be a four engine fan-in-wing configuration powered by Allison 501-H2 engines. The fans were 8 ft in diameter and the two propellers were 14’6” in diameter. Two fans were imbedded in each wing and a pitch fan was located in the nose of the aircraft. This entry was not as polished as those of the competitors, but the essentials were included (Figure 31). Throttles were used for thrust control in all modes of flight as seen in the cockpit drawings (Figure 32).

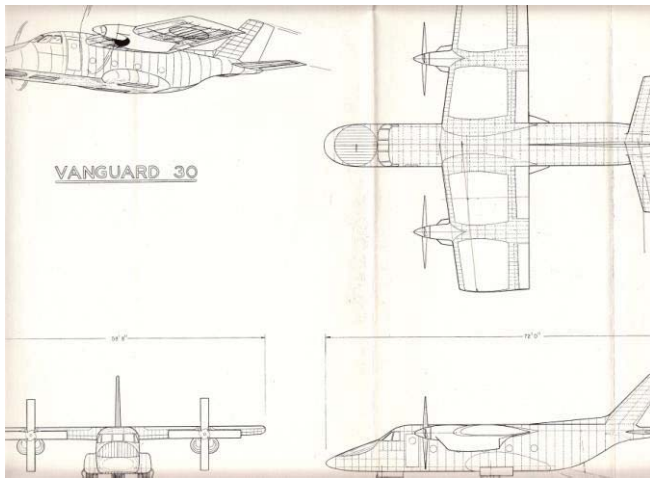

Figure 31. Vanguard Model 30 Lift Fan

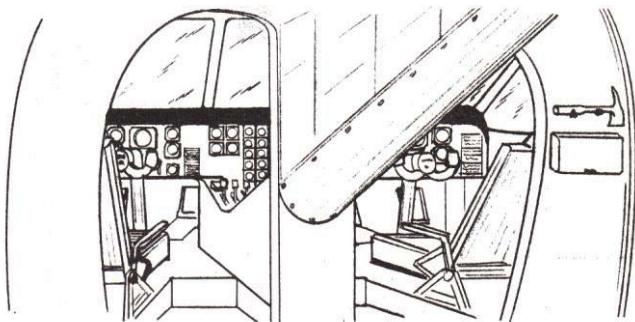

Figure 32. Vanguard Model 30 Cockpit

This design was reminiscent of the Ryan XV-5 Lift Fan that was a small concept demonstrator flow as an entry in a later competition for both an Army VTOL aircraft and as a potential combat search and rescue aircraft.

Breguet 941 VTOL TRANSPORT

The last entry in that 1961 VTOL Transport Request for Proposals (RFP) was submitted by an individual from Burlingame, CA and will not be discussed in detail in this paper. His proposal was to convert the existing Breguet 941 Short Takeoff and Landing (STOL) transport into a VTOL transport (Figure 33). It had insufficient content to permit a determination of the method designed to be used for thrust control, but it is the author’s speculation that the aircraft’s Power Levers would remain as installed (Figure 34).

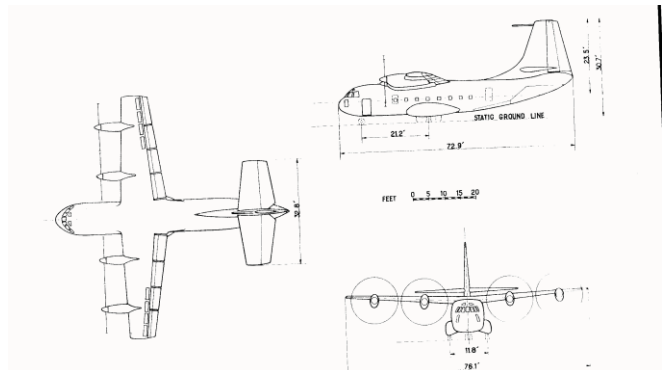

Figure 33. Breguet 941

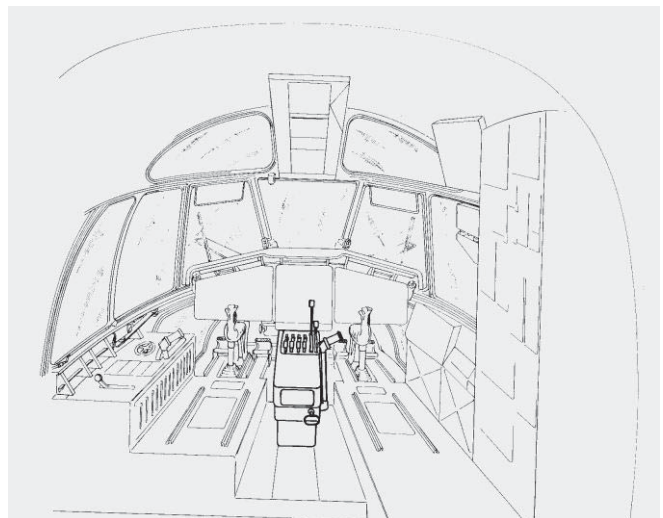

Figure 34. Breguet 941 Cockpit

SUMMARY

PAWNEE - VZ 1 (BOTH)	THROTTLE
VZ-1E	COLLECTIVE
DeLACKNER AEROCYCLE	THROTTLE
RYAN VZ-3	THROTTLE
DOAK VZ-4	COLLECTIVE
BOEING VZ-2A	COLLECTIVE
FAIRCHILD VZ-5	THROTTLE
BELL ATV	COLLECTIVE
HILLER X-18	THROTTLES
CURTISS-WRIGHT X-100	THROTTLE
FAIREY ROTODYNE	BOTH
DOUGLAS D-828, 829	BOTH
SIKORSKY TILTWING	THROTTLE TYPE
NORTH AMER CAN TILTWING-THROTTLES	
BELL/LOCKHEED 2064	THROTTLES
MCDONNELL COMPOUND	COLLECTIVE
MCDONNELL MODEL 175	COLLECTIVE
BOEING 137 TILTWING	BOTH
BOEING-WICHITA 900	COLLECTIVE TYPE
VANGUARD 30 LIFT FAN	THROTTLES
BREGUET 941	THROTTLE TYPE
11 THROTTLE, 7 COLLECTIVE, AND 3 BOTH	

Figure 35. Summary Chart

CONCLUDING REMARKS

The first civil VTOL aircraft, the now Augusta-Westland 609 tiltrotor, is scheduled for its first, often delayed deliveries in 2016. This design will be the first powered lift aircraft to be certificated by the FAA. The responsibility for its manufacture and introduction into the U.S. airspace system changed hands many times during its development – from Bell-Boeing, to Bell-Agusta, and finally Agusta-Westland. The Agusta-Westland Team is now continuing flight testing and dealing with the complex certification issues. It happens to have a conventional collective “stick” that the author understands resulted from insufficient space beneath the floor to accommodate a Power Lever such as the type used in the XV-15.

It is ironic that the United States has been investing in tiltrotor technology since the 1920s and produced the

world’s first operational tiltrotors – the MV and CV-22 Ospreys. Now, we will be buying the first, powered lift, VTOL civil aircraft from Agusta-Westland as a direct result of Bell’s parent company, Textron, and their decision to sell the technology and opt out of the civil tiltrotor market.

The French tiltrotor design Erica, also uses a conventional collective “stick” should it ever proceed beyond the design stages.

ACKNOWLEDGEMENTS

The Author wishes to recognize the contributions of the late Ronald M. Gerdes, a NASA research pilot, without whose archives, this paper would be incomplete. Also, Roger Connor of the Smithsonian’s Aeronautics Department was of great assistance tracking down details of some of the unusual aircraft discussed in this paper.

REFERENCES

1. S. Markman and B. Holder “Straight Up: A History of Vertical Flight,” 2000.

Wikipedia – The Free Encyclopedia

Tri-Service VTOL Transport Aircraft submissions from industry - April 1961