

NASA/TM—2019-220153



Calculating Factors of Safety and Margins of Safety From Interaction Equations

John K. Ramsey
Glenn Research Center, Cleveland, Ohio

NASA STI Program . . . in Profile

Since its founding, NASA has been dedicated to the advancement of aeronautics and space science. The NASA Scientific and Technical Information (STI) Program plays a key part in helping NASA maintain this important role.

The NASA STI Program operates under the auspices of the Agency Chief Information Officer. It collects, organizes, provides for archiving, and disseminates NASA's STI. The NASA STI Program provides access to the NASA Technical Report Server—Registered (NTRS Reg) and NASA Technical Report Server—Public (NTRS) thus providing one of the largest collections of aeronautical and space science STI in the world. Results are published in both non-NASA channels and by NASA in the NASA STI Report Series, which includes the following report types:

- TECHNICAL PUBLICATION. Reports of completed research or a major significant phase of research that present the results of NASA programs and include extensive data or theoretical analysis. Includes compilations of significant scientific and technical data and information deemed to be of continuing reference value. NASA counter-part of peer-reviewed formal professional papers, but has less stringent limitations on manuscript length and extent of graphic presentations.
- TECHNICAL MEMORANDUM. Scientific and technical findings that are preliminary or of specialized interest, e.g., “quick-release” reports, working papers, and bibliographies that contain minimal annotation. Does not contain extensive analysis.
- CONTRACTOR REPORT. Scientific and technical findings by NASA-sponsored contractors and grantees.
- CONFERENCE PUBLICATION. Collected papers from scientific and technical conferences, symposia, seminars, or other meetings sponsored or co-sponsored by NASA.
- SPECIAL PUBLICATION. Scientific, technical, or historical information from NASA programs, projects, and missions, often concerned with subjects having substantial public interest.
- TECHNICAL TRANSLATION. English-language translations of foreign scientific and technical material pertinent to NASA's mission.

For more information about the NASA STI program, see the following:

- Access the NASA STI program home page at <http://www.sti.nasa.gov>
- E-mail your question to help@sti.nasa.gov
- Fax your question to the NASA STI Information Desk at 757-864-6500
- Telephone the NASA STI Information Desk at 757-864-9658
- Write to:
NASA STI Program
Mail Stop 148
NASA Langley Research Center
Hampton, VA 23681-2199

NASA/TM—2019-220153



Calculating Factors of Safety and Margins of Safety From Interaction Equations

John K. Ramsey
Glenn Research Center, Cleveland, Ohio

National Aeronautics and
Space Administration

Glenn Research Center
Cleveland, Ohio 44135

September 2019

Level of Review: This material has been technically reviewed by technical management.

Available from

NASA STI Program
Mail Stop 148
NASA Langley Research Center
Hampton, VA 23681-2199

National Technical Information Service
5285 Port Royal Road
Springfield, VA 22161
703-605-6000

This report is available in electronic form at <http://www.sti.nasa.gov/> and <http://ntrs.nasa.gov/>

Calculating Factors of Safety and Margins of Safety From Interaction Equations

John K. Ramsey
National Aeronautics and Space Administration
Glenn Research Center
Cleveland, Ohio 44135

Summary

This report presents the derivation of the relationship between the factor of safety, the margin of safety, and a given interaction equation in two- or three-dimensional space. Factors of safety and margins of safety can be calculated from these interaction equations using either the closed-form solutions provided or the numerical methods mentioned in this report. The dual definition of the factor of safety is presented.

Introduction

For structures under combined loading, interaction equations have been used to predict structural failure without having to determine the principal stresses. The interaction equations account for the simultaneous effect of one stress (or load, or moment) component on another, for all possible component stress (or load, or moment) combinations.

In aerospace engineering, margins of safety are used to indicate the strength capability remaining in a structure. This report presents closed-form solutions of, and methods to determine, factors of safety and consequently margins of safety from interaction equations.

Nomenclature

a	exponent in interaction equation
b	exponent in interaction equation
$C_{1,2,3}$	constants in Equations (11) to (16) representing trigonometric functions for a given stress state (cf. Figure 1)
c	exponent in interaction equation
F	allowable stress
FS	factor of safety, definition 1. Calculated ratio S_2/S_1 . See Appendix A.
F_{su}	allowable ultimate shear stress
F_{sy}	allowable yield shear stress
F_{tu}	allowable tensile ultimate stress
F_{ty}	allowable tensile yield stress
f	calculated stress
FS	factor of safety, definition 2. Specified multiplying factor applied to calculated stresses (or corresponding calculated loads and or moments) for the purpose of creating a margin of safety. See Appendix A.
FS_u	ultimate factor of safety, definition 2. A specified multiplying factor applied to calculated stresses for the purpose of creating a margin of safety for the ultimate failure mode. See Appendix A.

\mathcal{FS}_y	yield factor of safety, definition 2. A specified multiplying factor applied to calculated stresses for the purpose of creating a margin of safety for the yield failure mode. See Appendix A.
MS	margin of safety. A measure of a structure's predicted reserve strength in excess of the product of the load or stress under consideration and the applicable factor of safety (definition 2 of factor of safety)
MS_u	margin of safety for the tensile, compressive, or shear ultimate condition
MS_y	margin of safety for the tensile, compressive, or shear yield condition
P	point in stress-ratio space that is interior to the failure surface or failure curve
P'	point in stress-ratio space on the failure surface or failure curve
R	stress ratio, f/F or $(\mathcal{FS})f/F$
R_b	bending stress ratio
R_s	shear stress ratio
R_{su}	shear stress ratio for the ultimate condition
R_{sy}	shear stress ratio for the yield condition
R_t	tensile stress ratio
R_{tu}	tensile stress ratio for the ultimate condition
R_{ty}	tensile stress ratio for the yield condition
S_1	magnitude of stress state corresponding to point P , interior to the failure surface in stress-ratio space. See Figure 1 and Figure 4 to Figure 9.
S_2	magnitude of stress state corresponding to point P' on the failure surface in stress-ratio space. See Figure 1 and Figure 4 to Figure 9.
SF	safety factor, used synonymously for the factor of safety definition 2 (\mathcal{FS})
α	angle defined in Figure 1
Δ	distance between points P' and P
φ	angle defined in Figure 1
$()'$	quantity at structural failure
$()_{i,j,k}$	indices representing different stress types, stress states, or failure modes

Stress Ratios

Interaction equations characterize combinations of stress, loads, or moments that cause structural failure (Refs. 1 to 7). These equations have been expressed in terms of load ratios, moment ratios, or stress ratios, where these ratios consist of loads, moments, or stresses of the same character. These interaction equations manifest themselves in the form of two-dimensional (2D) curves, three-dimensional (3D) surfaces, or boundaries in multidimensional space, and they can be created using theory (e.g., Ref. 3) or experiment (e.g., Ref. 1).

Reference 7 is one of the earlier publications describing the use of interaction equations to determine the allowable loads for a structure under combined loading. The approach was denoted therein as the "stress-ratio method." In this report, stress ratios will be used exclusively. However, the same outcomes would result when using load or moment ratios. The stress ratio R , consisting of stresses of the same character is defined as

$$R = \frac{f}{F} \quad (1)$$

where f is the calculated stress and F is the allowable stress.

The factor of safety¹ (\mathcal{FS}) can be incorporated into the stress ratios, and in those cases f is multiplied by the \mathcal{FS} in the numerator of the stress ratio. Here \mathcal{FS} is used to indicate a specified quantity, not to be confused by FS , which is a calculated quantity. Incorporating the \mathcal{FS} into Equation (1), the stress ratio takes on the following general form:

$$R = \frac{(\mathcal{FS})f}{F} \quad (2)$$

The ratio takes on the following form for the yield stress condition:

$$R_{ty} = \frac{(\mathcal{FS}_y)f}{F_{ty}} \quad (3)$$

where \mathcal{FS}_y is the specified yield factor of safety, and F_{ty} is the yield tensile stress allowable. A similar ratio can be constructed for the ultimate stress condition:

$$R_{tu} = \frac{(\mathcal{FS}_u)f}{F_{tu}} \quad (4)$$

where \mathcal{FS}_u is the specified ultimate factor of safety, and F_{tu} is the ultimate tensile stress allowable.

When a stress state involves shear, the following shear stress ratio for the yield condition is customarily expressed as

$$R_{sy} = \frac{(\mathcal{FS}_y)f}{F_{sy}} \quad (5)$$

where F_{sy} is the yield shear stress allowable.² The shear stress ratio for the ultimate condition is customarily expressed as

$$R_{su} = \frac{(\mathcal{FS}_u)f}{F_{su}} \quad (6)$$

where F_{su} is the ultimate shear stress allowable.²

¹The use of the “factor of safety” terminology can be confusing because it has a dual definition. The different symbols FS and \mathcal{FS} , corresponding to the two different definitions of the factor of safety, are used in this report for clarity, although this is typically not done in practice. Please see the definitions in the Nomenclature and Appendix A.

²If the yield or ultimate shear stress allowables are not available in the literature, it is customary to approximate the yield allowables as $F_{sy} = 0.6F_{ty}$ for alloy or carbon steels, and $F_{sy} = 0.55F_{ty}$ for stainless steels, and the ultimate allowables as $F_{su} = 0.6F_{tu}$ for alloy or carbon steels, and $F_{su} = 0.55F_{tu}$ for stainless steels (Ref. 6).

Interaction Equations

The interaction of one stress ratio with another at failure can be characterized using an interaction equation expressed as

$$(\Sigma R'_i)^a + (\Sigma R'_j)^b + (\Sigma R'_k)^c = 1 \quad \text{for } i \neq j \neq k \quad (7)$$

where the exponents a , b , and c are determined from experimental test results as demonstrated, for example, in Reference 1 and/or theory as demonstrated in Reference 3. The stress ratios R'_i , R'_j , and R'_k characterize the failure stress state and do not include the specified \mathcal{FS} because doing so would not truly reflect a failure stress state (unless $\mathcal{FS} = 1$). The summations and corresponding indices permit the combination of stress ratios as dictated by experiment or theory. With the inclusion of three separate summations, Equation (7) is more general than typically encountered, but the intent is to address some possible as-yet-to-be-encountered interaction equations. Any stress combinations not covered by Equation (7) can be addressed using and extending the techniques presented in this report.

Equation (7) may be plotted as a surface in 3D stress-ratio space as shown schematically in Figure 1. This surface is sometimes referred to as a “failure surface,” or it could be described as an interaction surface. Some interaction equations involve three stress ratios, with two of them being summed together, and in these situations Equation (7) can be plotted in 2D stress-ratio space as shown in Figure 2, where typically one would only encounter two stress ratios. It is up to the discretion of the analyst to decide which axes represent a given stress ratio or sum of stress ratios. Figure 3 is a plot of a generic interaction equation with two stress ratios.

Referring to Figure 1, the stress state at point P has coordinates $(\Sigma R_i, \Sigma R_j, \text{ and } \Sigma R_k)$, and it lies within the bounds of the failure (or interaction) surface (or equation), which indicates that the structure has reserve strength. The stress state at point P' has coordinates $(\Sigma R'_i, \Sigma R'_j, \text{ and } \Sigma R'_k)$ and lies on the failure (or interaction) surface, indicating that the structure does not have reserve strength at point P' .

Figure 2 shows a plot of interaction Equation (7), where the indices $i = 1$ and $j = 2, 3$ and where $R'_k = 0$. The stress state at point P has coordinates $(R_1, R_2 + R_3)$ and it lies within the bounds of the interaction equation, which indicates that the structure has reserve strength. The stress state at point P' has coordinates $(R'_1, R'_2 + R'_3)$ and lies on the interaction curve, indicating that the structure has no reserve strength at point P' .

Figure 3 shows a generic plot of interaction Equation (7) involving two stress ratios, where $i = 1$ and $j = 2$ and where $R'_k = 0$. The stress state at point P has coordinates (R_1, R_2) and just as in the case for Figure 2, it lies within the bounds of the interaction equation, which indicates that the structure has reserve strength. The stress state at point P' has coordinates (R'_1, R'_2) and lies on the interaction curve, indicating that the structure has no reserve strength at point P' .

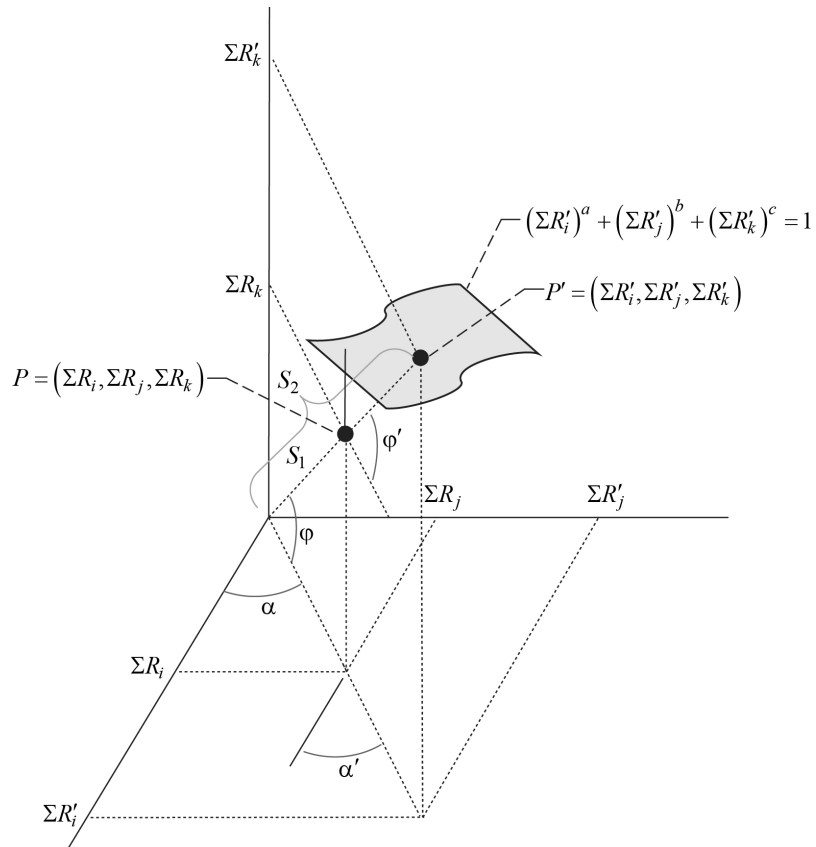

Figure 1.—Generic failure surface (in 3D stress-ratio space) illustrating magnitude S_1 of current stress-ratio state P and magnitude S_2 of stress-ratio state at failure P' for case where all stress-ratio sums ΣR are proportional up to failure.

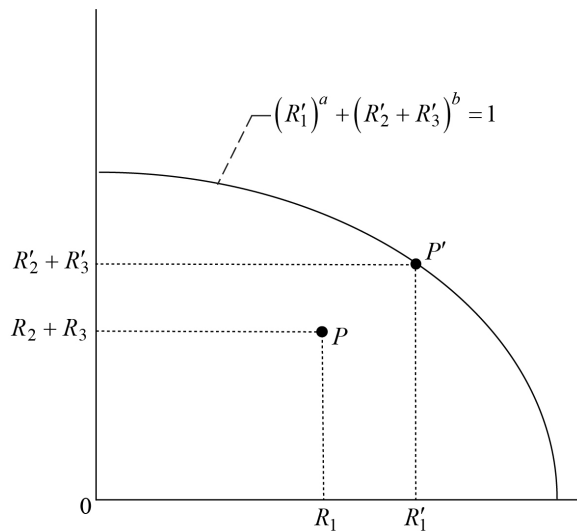

Figure 2.—Generic interaction curve (in 2D stress-ratio space) involving three stress ratios R , illustrating current stress-ratio state P and stress-ratio state at failure P' .

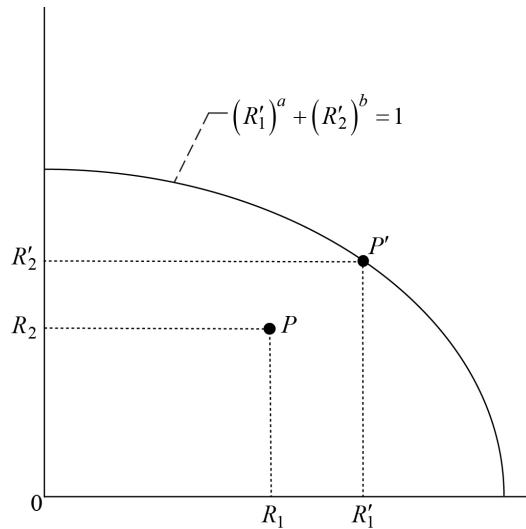

Figure 3.—Generic interaction curve (in 2D stress-ratio space) involving two stress ratios R , illustrating current stress-ratio state P and stress-ratio state at failure P' .

Interaction equations describe the relationships between the stress ratio combinations that exist at failure, but they do not necessarily describe the relationships between the stress ratios prior to failure. Figure (A.3.2.0-1) of Reference 3, and Figure 12 on page 2.11-6 of Reference 8 present three scenarios for the relationships between stress ratios prior to and at failure as depicted in Figure 4, Figure 5, and Figure 6 herein. Figure 4 presents the scenario where the stress ratio sum ($R_2 + R_3$) and R_1 increase proportionately up to structural failure at point P' . Figure 5 presents the case where the stress ratio sum ($R_2 + R_3$) remains constant as R_1 increases up to structural failure at point P' . Figure 6 presents the scenario where the stress ratio R_1 remains constant as the stress ratio sum ($R_2 + R_3$) increases up to structural failure at point P' .

Margin of Safety

In aerospace engineering, the margin of safety (MS) is used to indicate the degree to which the structure satisfies the strength requirements. One of the most concise definitions of the MS is given in Reference 4 as “the ratio of excess strength to the required strength,” where, in terms of stress, the excess strength is the difference between the allowable stress and the required stress, and the required stress is the product of the \mathcal{FS} and the calculated stress. The required stress is also known as the design stress. This is expressed mathematically as

$$MS = \frac{(\text{allowable stress}) - (\text{required stress})}{(\text{required stress})} = \frac{(\text{allowable stress})}{(\mathcal{FS})(\text{calculated stress})} - 1 \quad (8)$$

A $MS \geq 0$ is a prediction of adequate strength for the stress state at hand. In certain situations, a minimum positive MS may be imposed to account for unknowns not covered by the \mathcal{FS} in Equation (8).

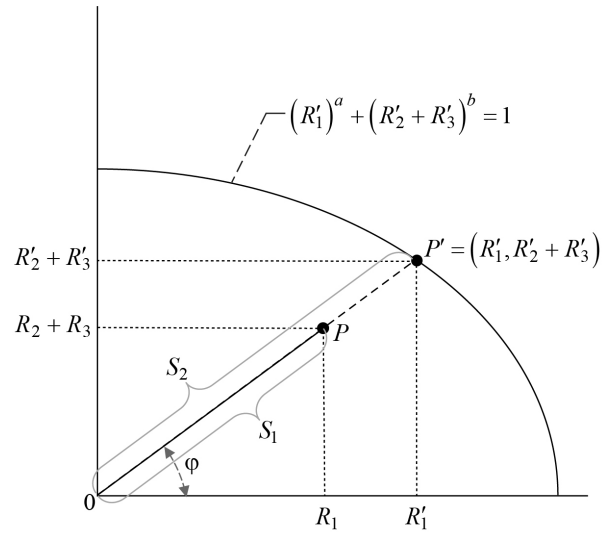

Figure 4.—Interaction curve (in 2D stress-ratio space) involving three stress ratios R , illustrating magnitude S_1 of current stress-ratio state P and magnitude S_2 of stress-ratio state at failure P' , for case where stress ratio R_1 is proportional to stress ratio sum $(R_2 + R_3)$ up to failure.

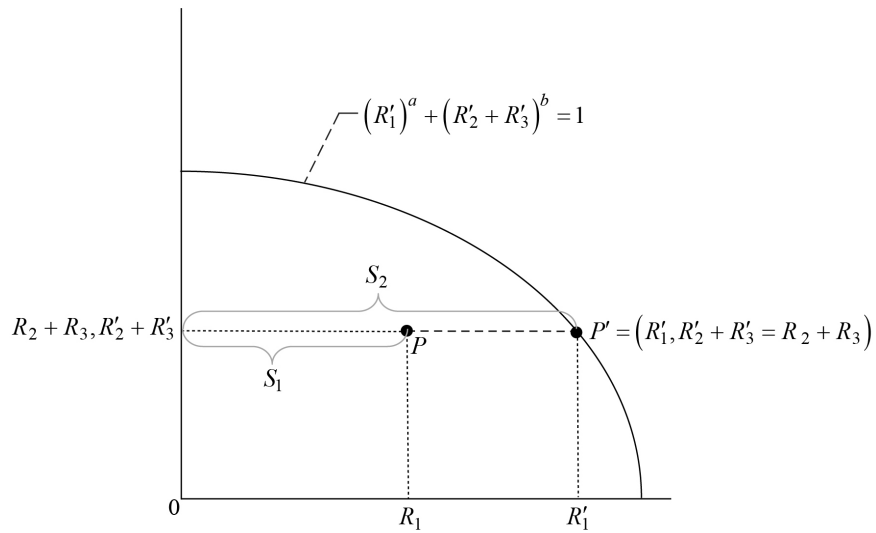

Figure 5.—Interaction curve (in 2D stress-ratio space), illustrating magnitude S_1 of current stress-ratio state P and magnitude S_2 of stress-ratio state at failure P' , for case where stress ratio sum $(R_2 + R_3)$ remains constant up to failure.

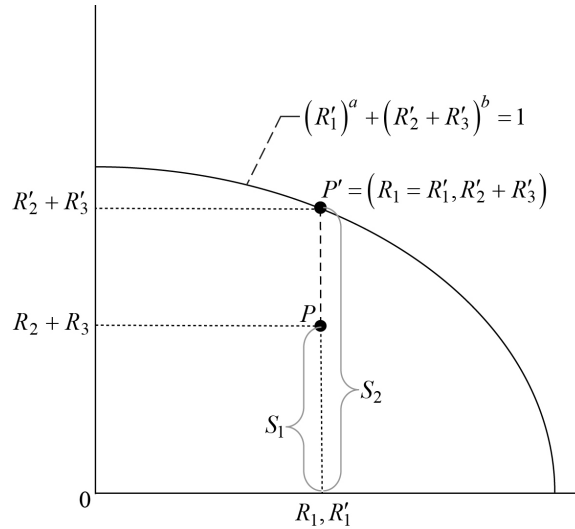

Figure 6.—Interaction curve (in 2D stress-ratio space), illustrating magnitude S_1 of current stress-ratio state P and magnitude S_2 of stress-ratio state at failure P' , for case where stress ratio R_1 remains constant up to failure.

For the tensile yield condition the margin of safety takes on the following form:

$$MS_y = \frac{(\text{allowable stress})}{(\mathcal{F}S_y)(\text{calculated stress})} - 1 = \frac{F_{ty}}{(\mathcal{F}S_y)f} - 1 = \frac{1}{R_{ty}} - 1 \quad (9a)$$

For the tensile ultimate condition the margin of safety takes on the following form:

$$MS_u = \frac{(\text{allowable stress})}{(\mathcal{F}S_u)(\text{calculated stress})} - 1 = \frac{F_{tu}}{(\mathcal{F}S_u)f} - 1 = \frac{1}{R_{tu}} - 1 \quad (9b)$$

For the shear yield condition the margin of safety takes on the following form:

$$MS_y = \frac{(\text{allowable stress})}{(\mathcal{F}S_y)(\text{calculated stress})} - 1 = \frac{F_{sy}}{(\mathcal{F}S_y)f} - 1 = \frac{1}{R_{sy}} - 1 \quad (9c)$$

For the shear ultimate condition the margin of safety takes on the following form:

$$MS_u = \frac{(\text{allowable stress})}{(\mathcal{F}S_u)(\text{calculated stress})} - 1 = \frac{F_{su}}{(\mathcal{F}S_u)f} - 1 = \frac{1}{R_{su}} - 1 \quad (9d)$$

The margin of safety Equations (8) and (9) are typical forms the analyst may encounter. The product of the yield factor of safety and the calculated stress is known as the design yield stress. The product of the ultimate factor of safety and the calculated stress is known as the design ultimate stress.

In addition to tension and shear stress states, Equations (9a) and (9b) may also be used for the compressive stress state as well, for the yield and ultimate conditions, respectively, where the compressive yield and ultimate strengths are substituted for F_{ty} and F_{tu} , respectively, here and in

Equations (3) and (4). The above equations assume that the yield factor of safety (definition 2) applies to the tensile, compressive, or shear yield condition, and that the ultimate factor of safety (definition 2) applies to the tensile, compressive, or shear ultimate condition.

Reference 5 presents interaction equations for combined load systems and their corresponding *MS* equations, but it does not explicitly show how to obtain the *MS* equation from its corresponding interaction equation. Reference 2 presents the *MS* equation and the interaction equation in terms of a common factor in 2D stress-ratio space, creating a system of two equations and two unknowns that can be solved for the common factor and consequently, the *MS*. Reference 9 extends the coverage of the *MS* topic presented in Reference 5, illustrating this same system of two equations and two unknowns, but extending the presentation in Reference 2 to that of a multidimensional stress-ratio space. One feature of the current report is to present the derivation of the system of two equations with the common factor.

Referring to Figure 1 to Figure 6, the allowable stress combination corresponds to point P' , and the required stress combination corresponds to point P , and Equation (8) becomes

$$MS = \frac{P' - P}{P} \quad (10)$$

Referring to Figure 1, the following relationships may be observed:

$$S_1 \cos \phi \cos \alpha = \Sigma R_i \rightarrow S_1 C_1 = \Sigma R_i \quad (11)$$

$$S_1 \cos \phi \sin \alpha = \Sigma R_j \rightarrow S_1 C_2 = \Sigma R_j \quad (12)$$

$$S_1 \sin \phi = \Sigma R_k \rightarrow S_1 C_3 = \Sigma R_k \quad (13)$$

$$S_2 \cos \phi \cos \alpha = \Sigma R'_i \rightarrow S_2 C_1 = \Sigma R'_i \quad (14)$$

$$S_2 \cos \phi \sin \alpha = \Sigma R'_j \rightarrow S_2 C_2 = \Sigma R'_j \quad (15)$$

$$S_2 \sin \phi = \Sigma R'_k \rightarrow S_2 C_3 = \Sigma R'_k \quad (16)$$

where the trigonometric terms are constants for a given stress state, and for conciseness these are denoted as C_1 , C_2 , and C_3 as shown above.

Although the following mathematics leading up to Equation (21) could have been omitted here, by inspection of Figure 1, it was decided to be more rigorous. Utilizing the equations for the distance between two points in 3D space, the ratio in Equation (10) becomes

$$\frac{P' - P}{P} = \frac{\sqrt{(\Sigma R'_i - \Sigma R_i)^2 + (\Sigma R'_j - \Sigma R_j)^2 + (\Sigma R'_k - \Sigma R_k)^2}}{\sqrt{(\Sigma R_i - 0)^2 + (\Sigma R_j - 0)^2 + (\Sigma R_k - 0)^2}} \quad (17)$$

Substituting Equations (11) to (16) into Equation (17) gives

$$\frac{P' - P}{P} = \frac{\sqrt{(S_2 C_1 - S_1 C_1)^2 + (S_2 C_2 - S_1 C_2)^2 + (S_2 C_3 - S_1 C_3)^2}}{\sqrt{(S_1 C_1)^2 + (S_1 C_2)^2 + (S_1 C_3)^2}} \quad (18)$$

Factoring out terms in Equation (18) yields

$$\frac{P' - P}{P} = \frac{\sqrt{(S_2 - S_1)^2 (C_1^2 + C_2^2 + C_3^2)}}{\sqrt{S_1^2 (C_1^2 + C_2^2 + C_3^2)}} \quad (19)$$

Rearranging Equation (19) simplifies to

$$\frac{P' - P}{P} = \frac{(S_2 - S_1) \sqrt{(C_1^2 + C_2^2 + C_3^2)}}{S_1 \sqrt{(C_1^2 + C_2^2 + C_3^2)}} = \frac{S_2 - S_1}{S_1} \quad (20)$$

Substituting Equation (20) into Equation (10), the *MS* becomes

$$MS = \frac{S_2 - S_1}{S_1} = \frac{S_2}{S_1} - 1 \quad (21)$$

As can be seen from Equation (21), the *MS* is expressed in terms of the distances S_1 and S_2 as defined in Figure 1, Figure 4, Figure 5, and Figure 6.

Factor of Safety

Reference 3 employs both definitions (mentioned previously) of the factor of safety. In regard to interaction equations, and in terms of variables used in this report, Reference 3 defines the factor of safety to be the calculated ratio of S_2 to S_1 . The factor of safety in this regard will be denoted as *FS*, thus differentiating it from the specified factor of safety, \mathcal{FS} . Therefore,

$$FS = \frac{S_2}{S_1} \quad (22a)$$

It should be noted as mentioned previously, that on the interaction curve or surface, the stress ratios do not incorporate the specified \mathcal{FS} (or equivalently \mathcal{FS} could be thought of as equaling 1 there). Therefore S_2 , which lies on the interaction curve or surface and is a function of stress ratios per Equations (14) to (16), does not incorporate a \mathcal{FS} . However, because S_1 is not on the interaction or failure surface and is a function of stress ratios per Equations (11) to (13), it may incorporate a \mathcal{FS} . This is shown symbolically in Equation (22b), where the subscript indices i could be replaced with index j or k . The derivation of Equation (22b) is presented in Appendix A.

$$FS = \frac{S_2}{S_1} = \frac{\sum \frac{f'_i}{F_i}}{\sum \frac{(\mathcal{FS})_i f_i}{F_i}} \quad (22b)$$

Equation (22b) shows that the factor of safety definition 1 is a function of the factor of safety definition 2. To avoid confusion between the factor of safety symbols in Equation (22b), the terminology

“safety factor” (SF) may be employed in place of the factor of safety (FS) definition 2. Please see Appendix A for a more detailed presentation on this.

Substituting Equation (22a) into Equation (21) gives the margin of safety in terms of the factor of safety (definition 1):

$$MS = FS - 1 \quad (23)$$

Again, it can be seen from comparing Equation (23) with Equation (8) that the FS is a function of FS .

Interaction Surfaces

In the following mathematical development through Equation (30), the stress ratios are assumed to be proportional to each other. This means that $\varphi' = \varphi$ and $\alpha' = \alpha$ in Figure 1. Multiplying both sides of Equation (22a) by $\cos \varphi \cos \alpha$ and rearranging gives

$$(FS)S_1 \cos \varphi \cos \alpha = S_2 \cos \varphi \cos \alpha \quad (24)$$

and upon substituting Equations (11) and (14) into Equation (24),

$$(FS)\Sigma R_i = \Sigma R'_i \quad (25)$$

Multiplying both sides of Equation (22a) by $\cos \varphi \sin \alpha$ and rearranging leads to

$$(FS)S_1 \cos \varphi \sin \alpha = S_2 \cos \varphi \sin \alpha \quad (26)$$

and upon substituting Equations (12) and (15) into Equation (26),

$$(FS)\Sigma R_j = \Sigma R'_j \quad (27)$$

Multiplying both sides of Equation (22a) by $\sin \varphi$ and rearranging gives

$$(FS)S_1 \sin \varphi = S_2 \sin \varphi \quad (28)$$

and upon substituting Equations (13) and (16) into Equation (28),

$$(FS)\Sigma R_k = \Sigma R'_k \quad (29)$$

Substituting Equations (25), (27), and (29) into Equation (7) generates Equation (30), which describes the relationships between stress ratios in terms of the FS for the scenario that all stress ratios maintain proportionality prior to and at failure.

$$\left[(FS)\Sigma R_i \right]^a + \left[(FS)\Sigma R_j \right]^b + \left[(FS)\Sigma R_k \right]^c = 1 \quad (30)$$

Equation (30) is valid for all failure surfaces in 3D space, including exponents with noninteger values, and corresponds to the failure path from S_1 to S_2 shown in Figure 1. This type of equation describing the relationships between the stress ratios prior to, and at failure, in terms of the factor of safety FS will be denoted from here on as the “factored interaction equation.”

For the case where ΣR_i is constant,

$$\Sigma R_i = \Sigma R'_i \quad (31)$$

Substituting Equations (31), (27), and (29) into Equation (7), the factored interaction equation for the case where $\Sigma R_i = \text{constant}$ and where ΣR_j and ΣR_k remain proportional to each other is

$$(\Sigma R_i)^a + [(FS)\Sigma R_j]^b + [(FS)\Sigma R_k]^c = 1 \quad (32)$$

and corresponds to the failure path from S_1 to S_2 shown in Figure 7.

For the case where $\Sigma R_j = \text{constant}$ and $\Sigma R_k = \text{constant}$,

$$\Sigma R_j = \Sigma R'_j \quad (33)$$

and

$$\Sigma R_k = \Sigma R'_k \quad (34)$$

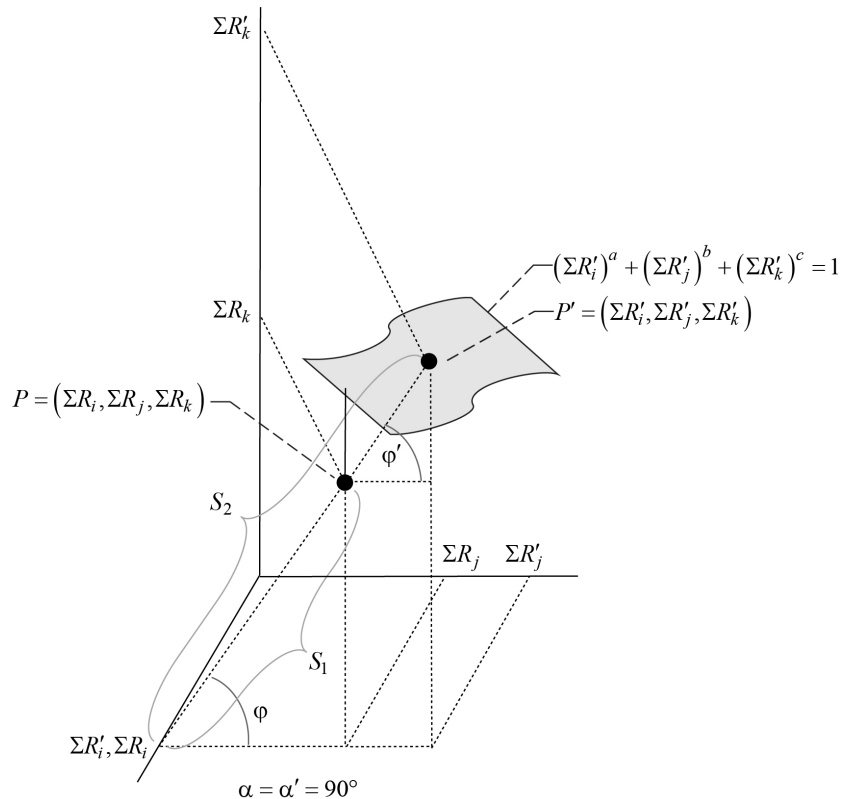

Figure 7.—Generic failure surface (in 3D stress-ratio space), illustrating magnitude S_1 of current stress-ratio state P and magnitude S_2 of stress-ratio state at failure P' , for case where stress ratio sum ΣR_i , remains constant up to failure.

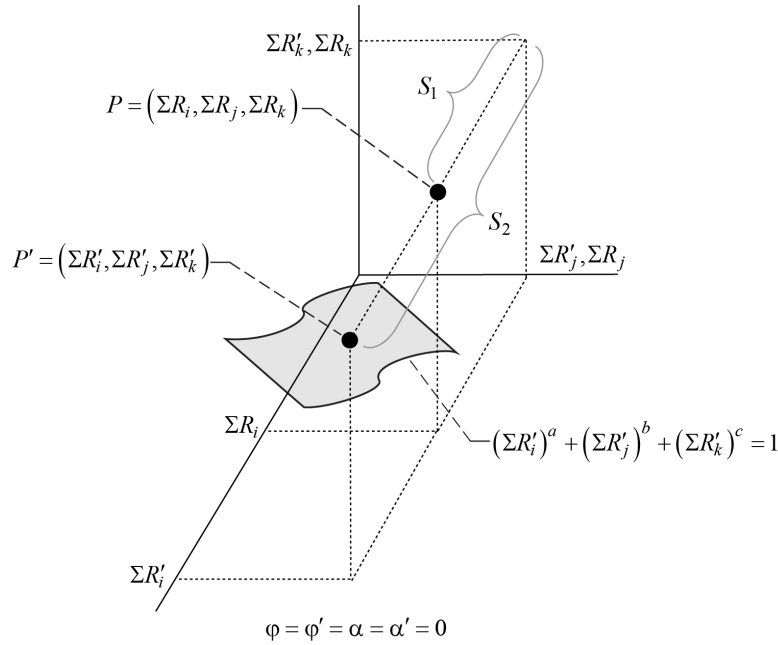

Figure 8.—Generic failure surface in (3D stress-ratio space) illustrating the magnitude S_1 of the current stress-ratio state P and magnitude S_2 of stress-ratio state at failure P' , for the case where stress ratio sum ΣR_i , and sum ΣR_k remain constant up to failure.

Substituting Equations (25), (33), and (34) into Equation (7) the factored interaction equation is

$$\left[(FS)\Sigma R_i \right]^a + (\Sigma R_j)^b + (\Sigma R_k)^c = 1 \quad (35)$$

and corresponds to the failure path from S_1 to S_2 shown in Figure 8.

The next section will consider failure or interaction curves in 2D stress-ratio space.

Interaction Curves

Interaction equations involving only two of the three summations in Equation (7), where $R'_k = 0$, are of the following form:

$$(\Sigma R'_i)^a + (\Sigma R'_j)^b = 1 \text{ for } i \neq j \quad (36)$$

Equation (36) may be plotted in 2D stress-ratio space. For combined loading scenarios consisting of only two stress ratios, the summation signs are not required. For example, when only tension and shear loadings are considered, the interaction Equation (36) becomes

$$(R'_t)^a + (R'_s)^b = 1 \quad (37)$$

Equation (36) is also often used for the case where tension, bending, and shear are considered for beam-like structures, in which case the interaction Equation (36) often is of the form

$$(R'_t + R'_b)^a + (R'_s)^b = 1 \quad (38)$$

where the first summation in Equation (36) is utilized, since the tension and bending stress act normal to the structural cross section, and thus the tension and bending stress ratios being of similar character may be added. For the case where both stress ratio sums are proportional to each other we substitute Equations (25) and (27) into Equation (36), yielding the factored interaction equation

$$[(FS)\Sigma R_i]^a + [(FS)\Sigma R_j]^b = 1 \quad (39)$$

which could have also been obtained by deleting the last term on the left hand side of Equation (30).

For the case where one of the stress ratio sums remains constant up to failure, for example when ΣR_j is constant, then

$$\Sigma R_j = \Sigma R'_j \quad (40)$$

Substituting Equation (40) and Equation (25) into Equation (36) yields the factored interaction equation for the case where ΣR_j is constant,

$$[(FS)\Sigma R_i]^a + (\Sigma R_j)^b = 1 \quad (41)$$

which could have also been obtained by deleting the last terms on the left hand side of Equation (35).

Equation (41) is equivalent in form to the case where ΣR_i is constant, which is

$$(\Sigma R_i)^a + [(FS)\Sigma R_j]^b = 1 \quad (42)$$

For the rest of this report, Equation (41) will be used to cover 2D factored interaction equations for the scenarios when one stress ratio sum remains constant up to failure.

Calculating the Factor of Safety and Consequently the Margin of Safety

Equations (30), (32), (35), (39), or (41) individually and Equation (23) constitute a system of two equations and two unknowns (FS and MS) that may be solved for the FS and subsequently the MS .

The FS may be determined from factored interaction Equations (30), (32), (35), (39), or (41), knowing the exponents a , b , and c and the stress ratios, R_i , R_j , and R_k . Once the FS is obtained, the MS may be calculated using Equation (23).

In many cases a closed-form solution for the FS may be obtained directly or by using an analytical approach such as Cardano's Method³ (Ref. 10) for equations up to order 3, which is outlined here. Table I to Table III provide these closed-form solutions for the FS as well as the constants used in Cardano's Method for interaction equations of the forms of Equations (30), (32), and (35). By subtracting 1 from the FS , the MS is obtained, as shown in Equation (23). Appendix B, Appendix C, and Appendix D present the derivations of the closed-form solutions presented in the tables along with the constants used in Cardano's Method.

To implement Cardano's Method, transform the factored interaction equation into the form

$$(FS)^3 + d(FS)^2 + e(FS) + g = 0 \quad (43)$$

Equation (43) may be solved for the factor of safety FS using Cardano's Method as follows:

1. Calculate $p = -\frac{d^2}{3} + e$
2. Calculate $q = 2\left(\frac{d}{3}\right)^3 - \frac{de}{3} + g$
3. Calculate $Q = \left(\frac{p}{3}\right)^3 + \left(\frac{q}{2}\right)^2$
4. Calculate $A = \sqrt[3]{-\frac{q}{2} + \sqrt{Q}}$
5. Calculate $B = \sqrt[3]{-\frac{q}{2} - \sqrt{Q}}$
6. Calculate $y_1 = A + B$
7. Calculate $y_{2,3} = -\frac{A+B}{2} \pm i\frac{A-B}{2}\sqrt{3}$
8. Calculate the factors of safety (roots): $(FS)_i = y_i - d/3$, where the $(FS)_i$ must be a real number
9. Calculate the minimum MS , $MS = \min[(FS)_i] - 1$

³Sometimes referred to in English as Cardan's Method.

TABLE I.—FACTORS OF SAFETY FS AND CONSTANTS USED IN CARDANO'S METHOD FOR FACTORED INTERACTION EQUATIONS OF THE FORM

$$[(FS)\Sigma R_i]^a + [(FS)\Sigma R_j]^b + [(FS)\Sigma R_k]^c = 1$$

[Where a , b , and c are integers and $MS = FS - 1$.]

$c = 1$			
$b \backslash a$	1	2	3
1	$\frac{1}{\Sigma R_i + \Sigma R_j + \Sigma R_k}$	-----	-----
2	$\frac{-(\Sigma R_j + \Sigma R_k) + \sqrt{(\Sigma R_j + \Sigma R_k)^2 + 4(\Sigma R_i)^2}}{2(\Sigma R_i)^2}$	$\frac{-\Sigma R_k + \sqrt{(\Sigma R_k)^2 + 4[(\Sigma R_i)^2 + (\Sigma R_j)^2]}}{2[(\Sigma R_i)^2 + (\Sigma R_j)^2]}$	-----
3	<p>Cardano's Method</p> <p style="text-align: center;">$d = 0$</p> <p style="text-align: center;">$e = \frac{\Sigma R_j + \Sigma R_k}{(\Sigma R_i)^3}$</p> <p style="text-align: center;">$g = -\frac{1}{(\Sigma R_i)^3}$</p>	<p>Cardano's Method</p> <p style="text-align: center;">$d = \frac{(\Sigma R_j)^2}{(\Sigma R_i)^3}$</p> <p style="text-align: center;">$e = \frac{\Sigma R_k}{(\Sigma R_i)^3}$</p> <p style="text-align: center;">$g = -\frac{1}{(\Sigma R_i)^3}$</p>	<p>Cardano's Method</p> <p style="text-align: center;">$d = 0$</p> <p style="text-align: center;">$e = \frac{\Sigma R_k}{(\Sigma R_i)^3 + (\Sigma R_j)^3}$</p> <p style="text-align: center;">$g = -\frac{1}{(\Sigma R_i)^3 + (\Sigma R_j)^3}$</p>
$c = 2$			
2	-----	$\frac{1}{\sqrt{(\Sigma R_i)^2 + (\Sigma R_j)^2 + (\Sigma R_k)^2}}$	-----
3	-----	<p>Cardano's Method</p> <p style="text-align: center;">$d = \frac{(\Sigma R_j)^2 + (\Sigma R_k)^2}{(\Sigma R_i)^3}$</p> <p style="text-align: center;">$e = 0$</p> <p style="text-align: center;">$g = -\frac{1}{(\Sigma R_i)^3}$</p>	<p>Cardano's Method</p> <p style="text-align: center;">$d = \frac{(\Sigma R_k)^2}{(\Sigma R_i)^3 + (\Sigma R_j)^3}$</p> <p style="text-align: center;">$e = 0$</p> <p style="text-align: center;">$g = -\frac{1}{(\Sigma R_i)^3 + (\Sigma R_j)^3}$</p>
$c = 3$			
3	-----	-----	$\frac{1}{\sqrt[3]{(\Sigma R_i)^3 + (\Sigma R_j)^3 + (\Sigma R_k)^3}}$

TABLE II.—FACTORS OF SAFETY FS AND CONSTANTS USED IN CARDANO'S METHOD FOR FACTORED INTERACTION EQUATIONS OF THE FORM

$$(\Sigma R_i)^a + [(FS)\Sigma R_j]^b + [(FS)\Sigma R_k]^c = 1$$

[Where a , b , and c are integers and $MS = FS - 1$.]

$c \backslash b$	1	2	3
1	$\frac{1 - (\Sigma R_i)^a}{\Sigma R_j + \Sigma R_k}$	-----	-----
2	$\frac{-\Sigma R_k + \sqrt{(\Sigma R_k)^2 + 4(\Sigma R_j)^2 [1 - (\Sigma R_i)^a]}}{2(\Sigma R_j)^2}$	$\sqrt{\frac{1 - (\Sigma R_i)^a}{(\Sigma R_j)^2 + (\Sigma R_k)^2}}$	-----
3	<p>Cardano's Method</p> <p>$d = 0$</p> <p>$e = \frac{\Sigma R_k}{(\Sigma R_j)^3}$</p> <p>$g = \frac{(\Sigma R_i)^a - 1}{(\Sigma R_j)^3}$</p>	<p>Cardano's Method</p> <p>$d = \frac{(\Sigma R_k)^2}{(\Sigma R_j)^3}$</p> <p>$e = 0$</p> <p>$g = \frac{(\Sigma R_i)^a - 1}{(\Sigma R_j)^3}$</p>	<p>$\sqrt[3]{\frac{1 - (\Sigma R_i)^a}{(\Sigma R_j)^3 + (\Sigma R_k)^3}}$</p>

TABLE III.—FACTORS OF SAFETY FS FOR FACTORED INTERACTION EQUATIONS OF THE FORM

$$[(FS)\Sigma R_i]^a + (\Sigma R_j)^b + (\Sigma R_k)^c = 1$$

[Where a , b , and c are integers and $MS = FS - 1$.]

$$\frac{\sqrt[a]{1 - (\Sigma R_j)^b - (\Sigma R_k)^c}}{\Sigma R_i}$$

Integer Exponents of Order 3 or Higher, or Noninteger Exponents

The previous sections presented closed-form solutions, including Cardano's Method for equations up to order 3, for solving for the FS from the factored interaction Equations (30), (32), and (35) (shown again below), and subsequently the MS . Closed-form solutions also exist that can be used to solve for the FS when the factored interaction equation is of integer order 4. However, it is more useful to adopt a general numerical procedure to solve for the FS from the factored interaction equations of any order, including cases where the exponents are not integers, as shown in Equations (44) and (45) (interaction equations from Ref. 11), for example:

$$[(FS)R_s]^{2.5} + [(FS)(R_t + R_b)]^{1.5} = 1 \tag{44}$$

$$[(FS)R_s]^{2.5} + [(FS)R_t]^{1.5} + (FS)R_b = 1 \tag{45}$$

Additionally, factored interaction equations may consist of the three separate summations of the following forms as presented previously in this report:

$$\left[(FS)\Sigma R_i \right]^a + \left[(FS)\Sigma R_j \right]^b + \left[(FS)\Sigma R_k \right]^c = 1 \quad (30)$$

$$(\Sigma R_i)^a + \left[(FS)\Sigma R_j \right]^b + \left[(FS)\Sigma R_k \right]^c = 1 \quad (32)$$

$$\left[(FS)\Sigma R_i \right]^a + (\Sigma R_j)^b + (\Sigma R_k)^c = 1 \quad (35)$$

To solve for the FS in these cases, it is useful to use a numerical root-finding algorithm to find the roots, the FS , of the rearranged factored interaction Equations (30), (32), and (35) of the following forms, respectively:

$$(FS)^a (\Sigma R_i)^a + (FS)^b (\Sigma R_j)^b + (FS)^c (\Sigma R_k)^c - 1 = 0 \quad (46)$$

$$(\Sigma R_i)^a + (FS)^b (\Sigma R_j)^b + (FS)^c (\Sigma R_k)^c - 1 = 0 \quad (47)$$

$$(FS)^a (\Sigma R_i)^a + (\Sigma R_j)^b + (\Sigma R_k)^c - 1 = 0 \quad (48)$$

Root-finding algorithms exist in the literature and may be programmed into the computer. One such algorithm is presented in Reference 12, where a combination of Newton-Raphson and bisection methods are employed and has been used successfully at the NASA Glenn Research Center. Software packages exist that inherently contain numerical root-finding algorithms, relieving the user of the need to write the root-finding code. It is beyond the scope of this report to further address the topic of root finding. The reader is encouraged to search out the appropriate algorithm from literature or on-line resources.

Conservative Approach in 2D Stress-Ratio Space

To calculate the minimum possible margin of safety, MS_{\min} ; that is, the shortest distance between the current stress state P and the interaction curve, as shown in Figure 9, a suggested method is as follows:

(1) For a selected set of points P' on the interaction curve, calculate Δ , the distance between points P' and P , using the standard equation for the distance between two points in a plane:

$$\Delta = \sqrt{(\Sigma R'_i - \Sigma R_i)^2 + (\Sigma R'_j - \Sigma R_j)^2} \quad (49)$$

(2) Calculate $S_1 = \sqrt{(\Sigma R_i)^2 + (\Sigma R_j)^2}$

(3) For the shortest distance Δ , calculate $MS_{\min} = \Delta/S_1$. It should be noticed from Figure 9, that the minimum $\Delta \leq S_2 - S_1$, and consequently $MS_{\min} = \Delta/S_1 \leq (S_2 - S_1)/S_1$.

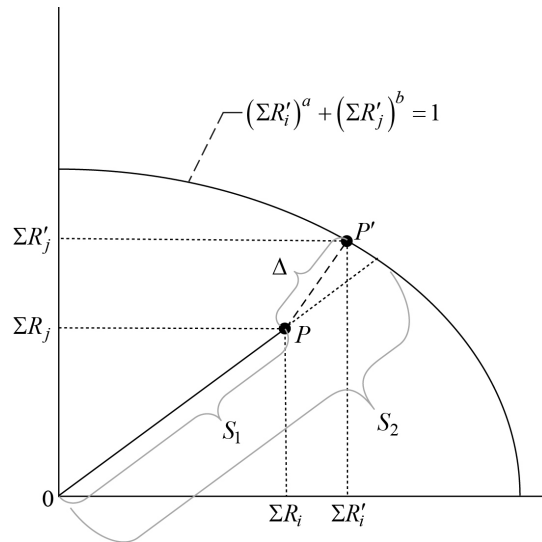

Figure 9.—Conservative interpretation of margin of safety (MS) (in 2D stress-ratio space), where $MS = \Delta/S_1$. Current stress-ratio state P and closest stress-ratio state at failure P' , are illustrated.

Conclusion

This report derives the relationship between factors of safety and interaction equations, denoted as the “factored interaction equation,” enabling the determination of the corresponding margins of safety. Factored interaction equations were considered for cases where all or some stress ratios remain proportional up to failure and the other stress ratios remain constant. Closed-form solutions including the constants used in Cardano’s Method, for the factor of safety and consequently the margin of safety, were presented in terms of stress ratios. Numerical root-finding methods are useful in situations where the interaction equations, and consequently the factored interaction equations, are of order 4 or higher, or they contain noninteger exponents.

Appendix A.—Factor of Safety and Safety Factor

The use of the “factor of safety” (*FS*) terminology can be confusing because it has a dual definition of being a calculated or a specified quantity, as explained below in definitions 1 and 2, respectively, and because at times the terminology “safety factor” is used synonymously for the “factor of safety” definition 2 as well. This has been the situation even in the earliest classical texts on aeronautical or aerospace structural analysis. Below are a few examples from the classical texts that illustrate this.

References 3 and 4 use the terms “factor of safety” and “safety factor” interchangeably. In Reference 3, Section B4, pages 44, 46, 47, and 52, the factor of safety is defined as a specified multiplier of stresses or moments in margin of safety (*MS*) equations. In Section B4.5, pages 5, 7, 8, and 13, this type of specified multiplying factor used in *MS* equations is referred to as “safety factor.”

In Reference 4, page 287, the factor of safety is defined as a specified multiplying factor of 1.5, while this same multiplying factor of 1.5 is denoted as a “safety factor” on pages 289 and 292.

Reference 5 defines/implies that the factors of safety can be either a calculated or a specified quantity. In Reference 5, page C1.6, the factor of safety is defined as the ratio of the strength of the structure to the limit loads. On page C1.7, it further defines the yield and ultimate factors of safety as ratios of yield and ultimate strength respectively, to limit load. In these cases the sense is that the factor of safety is a calculated quantity. However, on the same page C1.7, both the yield and ultimate factors of safety are also referred to in the sense of specified multiplying factors on the limit load.

The engineer needs to be aware of the context in which the terminology “safety factor” and “factor of safety” are used, and/or their symbolic placement in equations, to determine if they are a specified or calculated quantity.

A.1 Factor of Safety (*FS*), Definition 1

FS is a calculated ratio, typically of two quantities of the same character. These ratios can be loads, stresses, or moments:

$$FS = \frac{\text{strength}}{\text{load}}, \frac{\text{allowable stress}}{\text{required stress}}, \text{ or } \frac{\text{allowable stress}}{\text{design stress}} \quad (\text{A1})$$

It can be seen from Figure 1 and therefore from Equations (25), (27), and (29) that

$$FS = \frac{S_2}{S_1} = \frac{\Sigma R'_i}{\Sigma R_i} = \frac{\Sigma R'_j}{\Sigma R_j} = \frac{\Sigma R'_k}{\Sigma R_k} \quad (\varphi = \varphi', \alpha = \alpha') \quad (\text{A2})$$

and from Figure 7 that

$$FS = \frac{S_2}{S_1} = \frac{\Sigma R'_j}{\Sigma R_j} = \frac{\Sigma R'_k}{\Sigma R_k} \quad (\phi = \phi', \alpha = \alpha' = 90^\circ) \quad (\text{A3})$$

and lastly from Figure 8 that

$$FS = \frac{S_2}{S_1} = \frac{\Sigma R'_i}{\Sigma R_i} \quad (\varphi = \varphi' = \alpha = \alpha' = 0) \quad (\text{A4})$$

Substituting Equation (2) into Equations (A2) to (A4), and keeping in mind that the stress ratios on the interaction curve or surface R' do not have a specified \mathcal{FS} (or equivalently, \mathcal{FS} could be thought of as equaling 1 there), the relationship between the calculated FS and the specified \mathcal{FS} in terms of stress becomes

$$FS = \frac{S_2}{S_1} = \frac{\sum \frac{f'_i}{F_i}}{\sum \frac{(\mathcal{FS})_i f_i}{F_i}} \quad (\text{A5})$$

where the stress subscript indices i , could be replaced by j or k and where Equation (A5) is applicable to the stress states characterized by Equations (A2) to (A4).

If the allowable stress F and the specified factor of safety \mathcal{FS} can be taken outside of the summation in Equation (A5), the factor of safety in its simplified form becomes

$$FS = \frac{S_2}{S_1} = \frac{\sum \frac{f'}{F}}{\sum \frac{(\mathcal{FS}) f}{F}} = \frac{\frac{1}{F} \sum f'}{\frac{(\mathcal{FS})}{F} \sum f} = \frac{\sum f'}{(\mathcal{FS}) \sum f} \quad (\text{A6})$$

If in some cases it is not permissible to take one or both of the stress F and the specified factor of safety \mathcal{FS} outside of the summations, Equation (A5) can be simplified accordingly, but the fact remains that the calculated factor of safety is a function of the specified factor of safety.

The margin of safety may be expressed in terms of the calculated factor of safety as derived in the main text as Equation (23) and repeated here for completeness:

$$MS = FS - 1 \quad (\text{23})$$

A.2 Factor of Safety (\mathcal{FS}), Definition 2

\mathcal{FS} is a specified multiplying factor applied to loads or stresses for purposes of calculating margins of safety MS , and at times is referred to as a “safety factor”:

$$MS = \frac{\text{allowable stress}}{(\mathcal{FS}) \text{calculated stress}} - 1 \quad (\text{A7a})$$

$$MS = \frac{\text{allowable load}}{(\mathcal{FS}) \text{calculated load}} - 1 \quad (\text{A7b})$$

This definition of the \mathcal{FS} is usually associated with yield and ultimate strengths or stresses; namely, the yield and ultimate factors of safety are often denoted symbolically as \mathcal{FS}_y and \mathcal{FS}_u , respectively.

A.3 Safety Factor

The terminology “safety factor” has been used synonymously for the factor of safety definition 2, as previously mentioned. Applying this convention to Equations (A5) and (A7) and utilizing the symbol SF for safety factor avoids any ambiguity as shown in Equations (A8) and (A9):

$$FS = \frac{\sum \frac{f'_i}{F_i}}{\sum \frac{(SF)_i f_i}{F_i}} \quad (A8)$$

and

$$MS = \frac{\text{allowable stress}}{(SF) \text{ calculated stress}} - 1 = FS - 1 \quad (A9a)$$

$$MS = \frac{\text{allowable load}}{(SF) \text{ calculated load}} - 1 = FS - 1 \quad (A9b)$$

where Equation (23) has been incorporated into Equation (A9).

Appendix B.—Stress Ratios Maintaining Proportionality Up to Failure

This appendix derives the closed-form equations for the factor of safety (FS) and consequently the margin of safety (MS) for several examples of factored interaction equations in the form of Equation (30):

$$\left[(FS)\Sigma R_i \right]^a + \left[(FS)\Sigma R_j \right]^b + \left[(FS)\Sigma R_k \right]^c = 1 \quad (\text{B1})$$

involving different integer exponent values (1, 2, or 3).

B.1 $a = b = c = 1$

The factored interaction Equation (B1) becomes

$$\left[(FS)\Sigma R_i \right]^1 + \left[(FS)\Sigma R_j \right]^1 + \left[(FS)\Sigma R_k \right]^1 = 1 \quad (\text{B2})$$

and after factoring out the factor of safety FS , it may be obtained directly:

$$FS = \frac{1}{\Sigma R_i + \Sigma R_j + \Sigma R_k} \quad (\text{B3})$$

By substituting Equation (B3) into Equation (23), the MS is

$$MS = \frac{1}{\Sigma R_i + \Sigma R_j + \Sigma R_k} - 1 \quad (\text{B4})$$

B.2 $a = 2, b = c = 1$

The factored interaction Equation (B1) becomes

$$\left[(FS)\Sigma R_i \right]^2 + \left[(FS)\Sigma R_j \right]^1 + \left[(FS)\Sigma R_k \right]^1 = 1 \quad (\text{B5})$$

Rearranging Equation (B5) into a quadratic equation in FS ,

$$(\Sigma R_i)^2 (FS)^2 + (\Sigma R_j + \Sigma R_k)(FS) - 1 = 0 \quad (\text{B6})$$

The FS may be obtained using the quadratic formula

$$FS = \frac{-\left(\Sigma R_j + \Sigma R_k\right) + \sqrt{\left(\Sigma R_j + \Sigma R_k\right)^2 + 4\left(\Sigma R_i\right)^2}}{2\left(\Sigma R_i\right)^2} \quad (\text{B7})$$

where the negative square root in the numerator has been omitted because the FS must be positive. If you multiply the numerator and denominator of Equation (B7) by $\left(\Sigma R_j + \Sigma R_k\right) + \sqrt{\left(\Sigma R_j + \Sigma R_k\right)^2 + 4\left(\Sigma R_i\right)^2}$, the FS becomes

$$FS = \frac{2}{(\Sigma R_j + \Sigma R_k) + \sqrt{(\Sigma R_j + \Sigma R_k)^2 + 4(\Sigma R_i)^2}} \quad (B8)$$

which, ignoring the summation signs and considering a 2D stress-ratio space with $R_k = 0$, is equivalent to the FS presented in Table A3.5.0-1 of Reference 3.

Substituting Equation (B7) into Equation (23), the MS is

$$MS = \frac{-(\Sigma R_j + \Sigma R_k) + \sqrt{(\Sigma R_j + \Sigma R_k)^2 + 4(\Sigma R_i)^2}}{2(\Sigma R_i)^2} - 1 \quad (B9)$$

B.3 $a = 3, b = c = 1$

The factored interaction Equation (B1) becomes

$$[(FS)\Sigma R_i]^3 + [(FS)\Sigma R_j]^1 + [(FS)\Sigma R_k]^1 = 1 \quad (B10)$$

Rearranging Equation (B10) into the form of Equation (43), repeated here for convenience,

$$(FS)^3 + d(FS)^2 + e(FS) + g = 0 \quad (43)$$

gives

$$(FS)^3 (\Sigma R_i)^3 + (FS)(\Sigma R_j + \Sigma R_k) - 1 = 0 \quad (B11)$$

Then dividing Equation (B11) by $(\Sigma R_i)^3$ results in

$$(FS)^3 + (FS) \frac{(\Sigma R_j + \Sigma R_k)}{(\Sigma R_i)^3} - \frac{1}{(\Sigma R_i)^3} = 0 \quad (B12)$$

which, upon comparing Equations (B12) and (43), results in the following constants for Equation (43):

$$d = 0 \quad (B13a)$$

$$e = \frac{(\Sigma R_j + \Sigma R_k)}{(\Sigma R_i)^3} \quad (B13b)$$

$$g = -\frac{1}{(\Sigma R_i)^3} \quad (B13c)$$

which may be used in Cardano's Method (see section "Calculating the Factor of Safety and Consequently the Margin of Safety") to solve for the safety factor FS , and subsequently the MS using Equation (23).

B.4 $a = b = 2, c = 1$

The factored interaction Equation (B1) becomes

$$\left[(FS)\Sigma R_i \right]^2 + \left[(FS)\Sigma R_j \right]^2 + \left[(FS)\Sigma R_k \right]^1 = 1 \quad (\text{B14})$$

Rearranging Equation (B14) into a quadratic equation in FS ,

$$\left[(\Sigma R_i)^2 + (\Sigma R_j)^2 \right] (FS)^2 + \Sigma R_k (FS) - 1 = 0 \quad (\text{B15})$$

the factor of safety FS may be obtained using the quadratic formula

$$FS = \frac{-\Sigma R_k + \sqrt{(\Sigma R_k)^2 + 4 \left[(\Sigma R_i)^2 + (\Sigma R_j)^2 \right]}}{2 \left[(\Sigma R_i)^2 + (\Sigma R_j)^2 \right]} \quad (\text{B16})$$

Substituting Equation (B16) into Equation (23), the MS is

$$MS = \frac{-\Sigma R_k + \sqrt{(\Sigma R_k)^2 + 4 \left[(\Sigma R_i)^2 + (\Sigma R_j)^2 \right]}}{2 \left[(\Sigma R_i)^2 + (\Sigma R_j)^2 \right]} - 1 \quad (\text{B17})$$

B.5 $a = 3, b = 2, c = 1$

The factored interaction Equation (B1) becomes

$$\left[(FS)\Sigma R_i \right]^3 + \left[(FS)\Sigma R_j \right]^2 + \left[(FS)\Sigma R_k \right]^1 = 1 \quad (\text{B18})$$

and after rearranging Equation (B18) into the form of Equation (43), it is,

$$(FS)^3 (\Sigma R_i)^3 + (FS)^2 (\Sigma R_j)^2 + (FS)\Sigma R_k - 1 = 0 \quad (\text{B19})$$

Then dividing Equation (B19) by $(\Sigma R_i)^3$ it gives

$$(FS)^3 + (FS)^2 \frac{(\Sigma R_j)^2}{(\Sigma R_i)^3} + (FS) \frac{\Sigma R_k}{(\Sigma R_i)^3} - \frac{1}{(\Sigma R_i)^3} = 0 \quad (\text{B20})$$

which, upon comparing Equations (B20) and (43), results in the following constants for Equation (43):

$$d = \frac{(\Sigma R_j)^2}{(\Sigma R_i)^3} \quad (\text{B21a})$$

$$e = \frac{\Sigma R_k}{(\Sigma R_i)^3} \quad (\text{B21b})$$

$$g = -\frac{1}{(\Sigma R_i)^3} \quad (\text{B21c})$$

which may be used in Cardano's Method (see section "Calculating the Factor of Safety and Consequently the Margin of Safety") to solve for the factor of safety FS , and subsequently the MS , using Equation (23).

B.6 $a = 3, b = 3, c = 1$

The factored interaction Equation (B1) becomes

$$\left[(FS)\Sigma R_i \right]^3 + \left[(FS)\Sigma R_j \right]^3 + \left[(FS)\Sigma R_k \right]^1 = 1 \quad (\text{B22})$$

Rearranging Equation (B22) into the form of Equation (43) gives

$$(FS)^3 \left[(\Sigma R_i)^3 + (\Sigma R_j)^3 \right] + (FS)\Sigma R_k - 1 = 0 \quad (\text{B23})$$

Then dividing Equation (B23) by $\left[(\Sigma R_i)^3 + (\Sigma R_j)^3 \right]$ gives

$$(FS)^3 + (FS) \frac{\Sigma R_k}{(\Sigma R_i)^3 + (\Sigma R_j)^3} - \frac{1}{(\Sigma R_i)^3 + (\Sigma R_j)^3} = 0 \quad (\text{B24})$$

which upon comparing Equations (B24) and (43), results in the following constants for Equation (43):

$$d = 0 \quad (\text{B25a})$$

$$e = \frac{\Sigma R_k}{(\Sigma R_i)^3 + (\Sigma R_j)^3} \quad (\text{B25b})$$

$$g = -\frac{1}{(\Sigma R_i)^3 + (\Sigma R_j)^3} \quad (\text{B25c})$$

which may be used in Cardano's Method (see section "Calculating the Factor of Safety and Consequently the Margin of Safety") to solve for the factor of safety FS , and subsequently the MS , using Equation (23).

B.7 $a = b = c = 2$

The factored interaction Equation (B1) becomes

$$\left[(FS)\Sigma R_i \right]^2 + \left[(FS)\Sigma R_j \right]^2 + \left[(FS)\Sigma R_k \right]^2 = 1 \quad (\text{B26})$$

After factoring out the factor of safety FS , it may be obtained directly:

$$FS = \frac{1}{\sqrt{(\Sigma R_i)^2 + (\Sigma R_j)^2 + (\Sigma R_k)^2}} \quad (\text{B27})$$

Substituting Equation (B27) into Equation (23), the MS is

$$MS = \frac{1}{\sqrt{(\Sigma R_i)^2 + (\Sigma R_j)^2 + (\Sigma R_k)^2}} - 1 \quad (\text{B28})$$

B.8 $a = 3, b = c = 2$

The factored interaction Equation (B1) becomes

$$\left[(FS)\Sigma R_i \right]^3 + \left[(FS)\Sigma R_j \right]^2 + \left[(FS)\Sigma R_k \right]^2 = 1 \quad (\text{B29})$$

and after rearranging Equation (B29), it is as follows:

$$(FS)^3 (\Sigma R_i)^3 + (FS)^2 \left[(\Sigma R_j)^2 + (\Sigma R_k)^2 \right] - 1 = 0 \quad (\text{B30})$$

Dividing Equation (B30) through by $(\Sigma R_i)^3$ then gives

$$(FS)^3 + (FS)^2 \frac{(\Sigma R_j)^2 + (\Sigma R_k)^2}{(\Sigma R_i)^3} - \frac{1}{(\Sigma R_i)^3} = 0 \quad (\text{B31})$$

By comparing Equations (B31) and (43), the following constants for Equation (42) are obtained:

$$d = \frac{(\Sigma R_j)^2 + (\Sigma R_k)^2}{(\Sigma R_i)^3} \quad (\text{B32a})$$

$$e = 0 \quad (\text{B32b})$$

$$g = -\frac{1}{(\Sigma R_i)^3} \quad (\text{B32c})$$

which may be used in Cardano's Method (see section "Calculating the Factor of Safety and Consequently the Margin of Safety") to solve for the safety factor FS , and subsequently the MS using Equation (23).

B.9 $a = b = 3, c = 2$

Again, starting with the factored interaction Equation (B1),

$$\left[(FS)\Sigma R_i \right]^3 + \left[(FS)\Sigma R_j \right]^3 + \left[(FS)\Sigma R_k \right]^2 = 1 \quad (B33)$$

and rearranging Equation (B33) gives

$$(FS)^3 \left[(\Sigma R_i)^3 + (\Sigma R_j)^3 \right] + (FS)^2 (\Sigma R_k)^2 - 1 = 0 \quad (B34)$$

Then dividing Equation (B34) through by $\left[(\Sigma R_i)^3 + (\Sigma R_j)^3 \right]$ gives

$$(FS)^3 + (FS)^2 \frac{(\Sigma R_k)^2}{(\Sigma R_i)^3 + (\Sigma R_j)^3} - \frac{1}{(\Sigma R_i)^3 + (\Sigma R_j)^3} = 0 \quad (B35)$$

By comparing Equations (B35) and (43), the following constants for Equation (43) are obtained:

$$d = \frac{(\Sigma R_k)^2}{(\Sigma R_i)^3 + (\Sigma R_j)^3} \quad (B36a)$$

$$e = 0 \quad (B36b)$$

$$g = -\frac{1}{(\Sigma R_i)^3 + (\Sigma R_j)^3} \quad (B36c)$$

which may be used in Cardano’s Method (see section “Calculating the Factor of Safety and Consequently the Margin of Safety”) to solve for the factor of safety FS and subsequently the MS using Equation (23).

B.10 $a = b = c = 3$

The factored interaction Equation (B1) becomes

$$\left[(FS)\Sigma R_i \right]^3 + \left[(FS)\Sigma R_j \right]^3 + \left[(FS)\Sigma R_k \right]^3 = 1 \quad (B37)$$

and after factoring out the factor of safety FS , it may be obtained directly:

$$FS = \frac{1}{\sqrt[3]{(\Sigma R_i)^3 + (\Sigma R_j)^3 + (\Sigma R_k)^3}} \quad (B38)$$

Substituting Equation (B38) into Equation (23), the MS is

$$MS = \frac{1}{\sqrt[3]{(\Sigma R_i)^3 + (\Sigma R_j)^3 + (\Sigma R_k)^3}} - 1 \quad (B39)$$

Appendix C.—One Stress Ratio Sum Remaining Constant up to Failure

This appendix derives the closed-form equations for the factor of safety (FS) and consequently the margins of safety (MS) for several examples of factored interaction equations in the form of Equation (32):

$$(\Sigma R_i)^a + [(FS)\Sigma R_j]^b + [(FS)\Sigma R_k]^c = 1 \quad (C1)$$

when one exponent (here, a) is an integer constant and the others are different integer exponent values (1, 2, or 3).

C.1 $b = c = 1$

The factored interaction Equation (C1) is

$$(\Sigma R_i)^a + [(FS)\Sigma R_j]^1 + [(FS)\Sigma R_k]^1 = 1 \quad (C2)$$

Factoring out the factor of safety FS ,

$$FS(\Sigma R_j + \Sigma R_k) = 1 - (\Sigma R_i)^a \quad (C3)$$

and solving for the FS gives

$$FS = \frac{1 - (\Sigma R_i)^a}{\Sigma R_j + \Sigma R_k} \quad (C4)$$

Upon substituting Equation (C4) into Equation (23), the MS becomes

$$MS = \frac{1 - (\Sigma R_i)^a}{\Sigma R_j + \Sigma R_k} - 1 \quad (C5)$$

C.2 $b = 2, c = 1$

The factored interaction Equation (C1) becomes

$$(\Sigma R_i)^a + [(FS)\Sigma R_j]^2 + [(FS)\Sigma R_k]^1 = 1 \quad (C6)$$

Recognizing that Equation (C6) is a quadratic equation in FS ,

$$(FS)^2(\Sigma R_j)^2 + (FS)^1(\Sigma R_k)^1 + (\Sigma R_i)^a - 1 = 0 \quad (C7)$$

and solving for FS results in

$$FS = \frac{-\Sigma R_k + \sqrt{(\Sigma R_k)^2 + 4(\Sigma R_j)^2 [1 - (\Sigma R_i)^a]}}{2(\Sigma R_j)^2} \quad (C8)$$

where the negative square root in the numerator has been omitted because the FS must be positive. Substituting Equation (C8) into Equation (23), the MS becomes

$$MS = \frac{-\Sigma R_k + \sqrt{(\Sigma R_k)^2 + 4(\Sigma R_j)^2 [1 - (\Sigma R_i)^a]}}{2(\Sigma R_j)^2} - 1 \quad (C9)$$

C.3 $b = 3, c = 1$

The factored interaction Equation (C1) becomes

$$(\Sigma R_i)^a + [(FS)\Sigma R_j]^3 + [(FS)\Sigma R_k]^1 = 1 \quad (C10)$$

transforming Equation (C10) into the form of Equation (43), repeated here for convenience,

$$(FS)^3 + d(FS)^2 + e(FS) + g = 0 \quad (43)$$

it follows that

$$(FS)^3 (\Sigma R_j)^3 + (FS)(\Sigma R_k) + (\Sigma R_i)^a - 1 = 0 \quad (C11)$$

Dividing Equation (C11) by $(\Sigma R_j)^3$ gives

$$(FS)^3 + (FS) \frac{(\Sigma R_k)}{(\Sigma R_j)^3} + \frac{(\Sigma R_i)^a - 1}{(\Sigma R_j)^3} = 0 \quad (C12)$$

By comparing Equations (C12) and (43), the following constants for Equation (43) are obtained:

$$d = 0 \quad (C13a)$$

$$e = \frac{(\Sigma R_k)}{(\Sigma R_j)^3} \quad (C13b)$$

$$g = \frac{(\Sigma R_i)^a - 1}{(\Sigma R_j)^3} \quad (C13c)$$

which may be used in Cardano’s Method (see section “Calculating the Factor of Safety and Consequently the Margin of Safety”) to solve for FS and consequently, the MS using Equation (23).

C.4 $b = c = 2$

The factored interaction Equation (C1) becomes

$$(\Sigma R_i)^a + [(FS)\Sigma R_j]^2 + [(FS)\Sigma R_k]^2 = 1 \quad (C14)$$

Rearranging and factoring out the FS gives

$$(FS)^2 [(\Sigma R_j)^2 + (\Sigma R_k)^2] = 1 - (\Sigma R_i)^a \quad (C15)$$

and solving for the FS results in

$$FS = \sqrt{\frac{1 - (\Sigma R_i)^a}{(\Sigma R_j)^2 + (\Sigma R_k)^2}} \quad (C16)$$

Substituting Equation (C16) into Equation (23), the MS is

$$MS = \sqrt{\frac{1 - (\Sigma R_i)^a}{(\Sigma R_j)^2 + (\Sigma R_k)^2}} - 1 \quad (C17)$$

C.5 $b = 3, c = 2$

The factored interaction Equation (C1) becomes

$$(\Sigma R_i)^a + [(FS)\Sigma R_j]^3 + [(FS)\Sigma R_k]^2 = 1 \quad (C18)$$

Transforming Equation (C18) into the form of Equation (43), as follows,

$$(FS)^3 (\Sigma R_j)^3 + (FS)^2 (\Sigma R_k)^2 + (\Sigma R_i)^a - 1 = 0 \quad (C19)$$

Dividing Equation (C19) by $(\Sigma R_j)^3$ gives

$$(FS)^3 + (FS)^2 \frac{(\Sigma R_k)^2}{(\Sigma R_j)^3} + \frac{(\Sigma R_i)^a - 1}{(\Sigma R_j)^3} = 0 \quad (C20)$$

By comparing Equations (C20) and (43), the following constants for Equation (43) are obtained:

$$d = \frac{(\Sigma R_k)^2}{(\Sigma R_j)^3} \quad (C21a)$$

$$e = 0 \quad (C21b)$$

$$g = \frac{(\Sigma R_i)^a - 1}{(\Sigma R_j)^3} \quad (C21c)$$

which may be used in Cardano's Method (see section "Calculating the Factor of Safety and Consequently the Margin of Safety") to solve for FS and consequently, the MS using Equation (23).

C.6 $b = 3, c = 3$

The factored interaction Equation (C1) becomes

$$(\Sigma R_i)^a + [(FS)\Sigma R_j]^3 + [(FS)\Sigma R_k]^3 = 1 \quad (C22)$$

Rearranging and factoring out FS in Equation (C22) gives

$$(FS)^3 \left[(\Sigma R_j)^3 + (\Sigma R_k)^3 \right] = 1 - (\Sigma R_i)^a \quad (C23)$$

and solving for FS yields

$$FS = \sqrt[3]{\frac{1 - (\Sigma R_i)^a}{(\Sigma R_j)^3 + (\Sigma R_k)^3}} \quad (C24)$$

Substituting Equation (C24) into Equation (23), the MS becomes

$$MS = \sqrt[3]{\frac{1 - (\Sigma R_i)^a}{(\Sigma R_j)^3 + (\Sigma R_k)^3}} - 1 \quad (C25)$$

Appendix D.—Two Stress Ratio Sums Remaining Constant up to Failure

This appendix derives the closed-form equation for the factor of safety (FS) and consequently the margin of safety (MS) for factored interaction equations in the form of Equation (35):

$$\left[(FS)\Sigma R_i \right]^a + (\Sigma R_j)^b + (\Sigma R_k)^c = 1 \quad (D1)$$

involving any integer exponent.

By rewriting Equation (D1) in the form

$$(FS)^a (\Sigma R_i)^a = 1 - (\Sigma R_j)^b - (\Sigma R_k)^c \quad (D2)$$

and solving for the FS , the result is

$$FS = \frac{\sqrt[a]{1 - (\Sigma R_j)^b - (\Sigma R_k)^c}}{\Sigma R_i} \quad (D3)$$

Substituting Equation (D3) into Equation (23), the MS becomes

$$MS = \frac{\sqrt[a]{1 - (\Sigma R_j)^b - (\Sigma R_k)^c}}{\Sigma R_i} - 1 \quad (D4)$$

References

1. Steeve, B.E.; and Wingate, R.J.: Aerospace Threaded Fastener Strength in Combined Shear and Tension Loading. NASA/TM—2012-217454, 2012. <http://ntrs.nasa.gov>
2. Sarafin, Thomas P.; and Larson, Wiley: Spacecraft Structures and Mechanisms—From Concept to Launch. Springer, Netherlands, 1995, p. 244.
3. Astronautic Structures Manual. Vol. 1, Sect. A3, NASA TM X-73305, 1975.
4. Peery, David J.: Aircraft Structures. McGraw-Hill Book Co., New York, NY, 1950.
5. Bruhn, E.F.: Analysis and Design of Flight Vehicle Structures. S.R. Jacobs & Associates, Inc., Tri-State Offset Company, 1973, pp. C1.6–C1.7.
6. Barrett, Richard T.: Fastener Design Manual. NASA RP-1228, 1990, p. 21. <http://ntrs.nasa.gov>
7. Shanley, F.R.; and Ryder, E.I.: Stress Ratios: The Answer to the Combined Loading Problem. Aviation, 1937.
8. Blodgett, Omer W.: Design of Welded Structures. James F. Lincoln Arc Welding Foundation, Cleveland, OH, 1966.
9. McCombs, William F.: A Supplement to Analysis & Design of Flight Vehicle Structures, Bruhn, For Increased Scope and Usefulness. Datatec, Dallas, TX, 1998.
10. Korn, Granino A.; and Korn, Theresa M.: Mathematical Handbook for Scientists and Engineers: Definitions, Theorems, and Formulas for Reference and Review. McGraw-Hill, New York, NY, 1961, p. 23.
11. Requirements for Threaded Fastening Systems in Spaceflight Hardware. NASA-STD-5020A, 2018.
12. Press, William H., et al.: Numerical Recipes: The Art of Scientific Computing. University Press, Cambridge, MA, 1990, p. 258.

