

# Current options for the nuclear fuel cycle:

1- Spent fuel disposal

2- Spent fuel reprocessing and Pu recovery

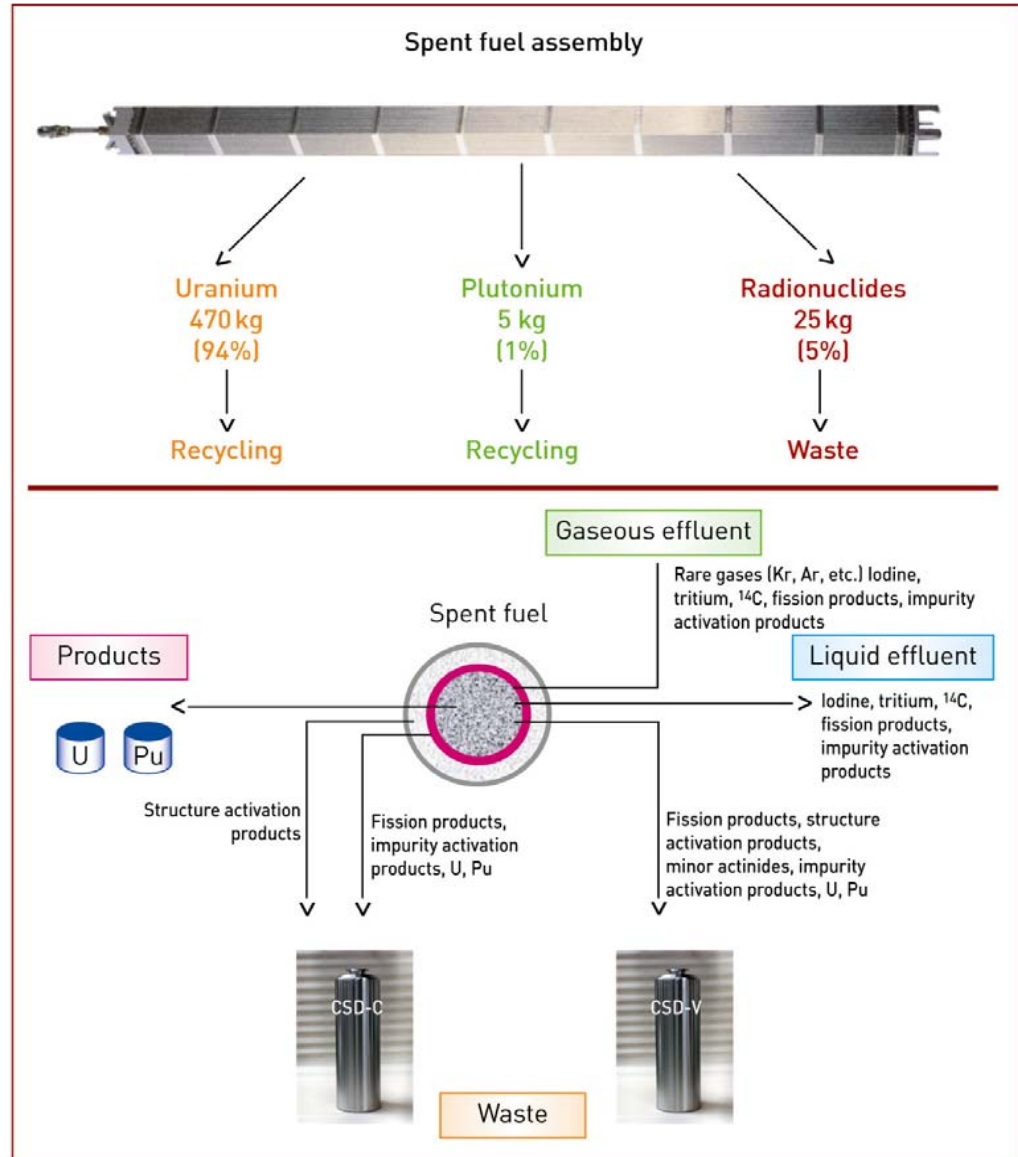
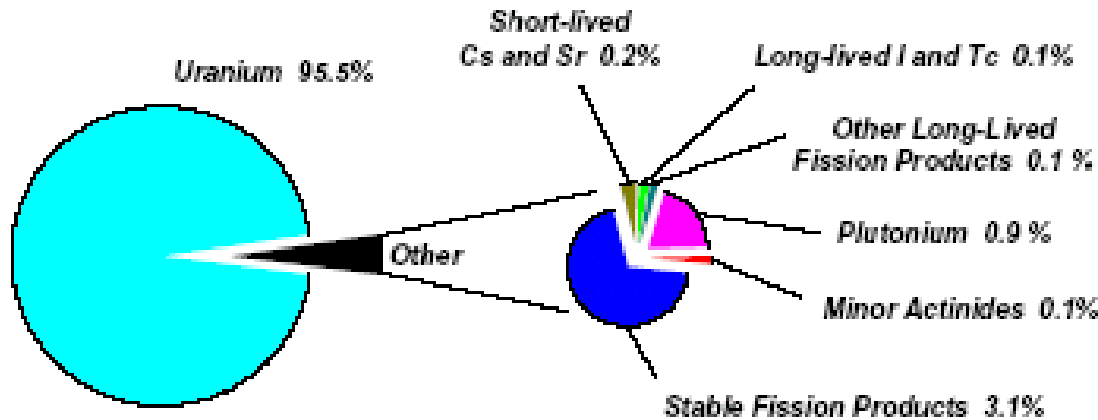

Figure 1 : spent UOX fuel content

## Composition of Spent Nuclear Fuel (Standard PWR 33GW/t, 10 yr. cooling)



Most of the hazard stems from Pu, MA and some LLFP when released into the environment, and their disposal requires isolation in stable deep geological formations with adequate waste forms.

A measure of the hazard is provided by the radiotoxicity arising from their radioactive nature.

### 1 tonne of SNF contains:

955.4 kg U  
8,5 kg Pu

### Minor Actinides (MAs)

0,5 kg <sup>237</sup>Np  
0,6 kg Am  
0,02 kg Cm

### Long-Lived fission Products (LLFPs)

0,2 kg <sup>129</sup>I  
0,8 kg <sup>99</sup>Tc  
0,7 kg <sup>93</sup>Zr  
0,3 kg <sup>135</sup>Cs

### Short-Lived fission products (SLFPs)

1 kg <sup>137</sup>Cs  
0,7 kg <sup>90</sup>Sr

### Stable Isotopes

10,1 kg Lanthanides  
21,8 kg other stable

**Evolution of the radiotoxic inventory, expressed in sievert per tonne of initial heavy metal (uranium) (Sv/ihmt) of UOX spent fuel unloaded at 60 GW d/t, versus time (years).**

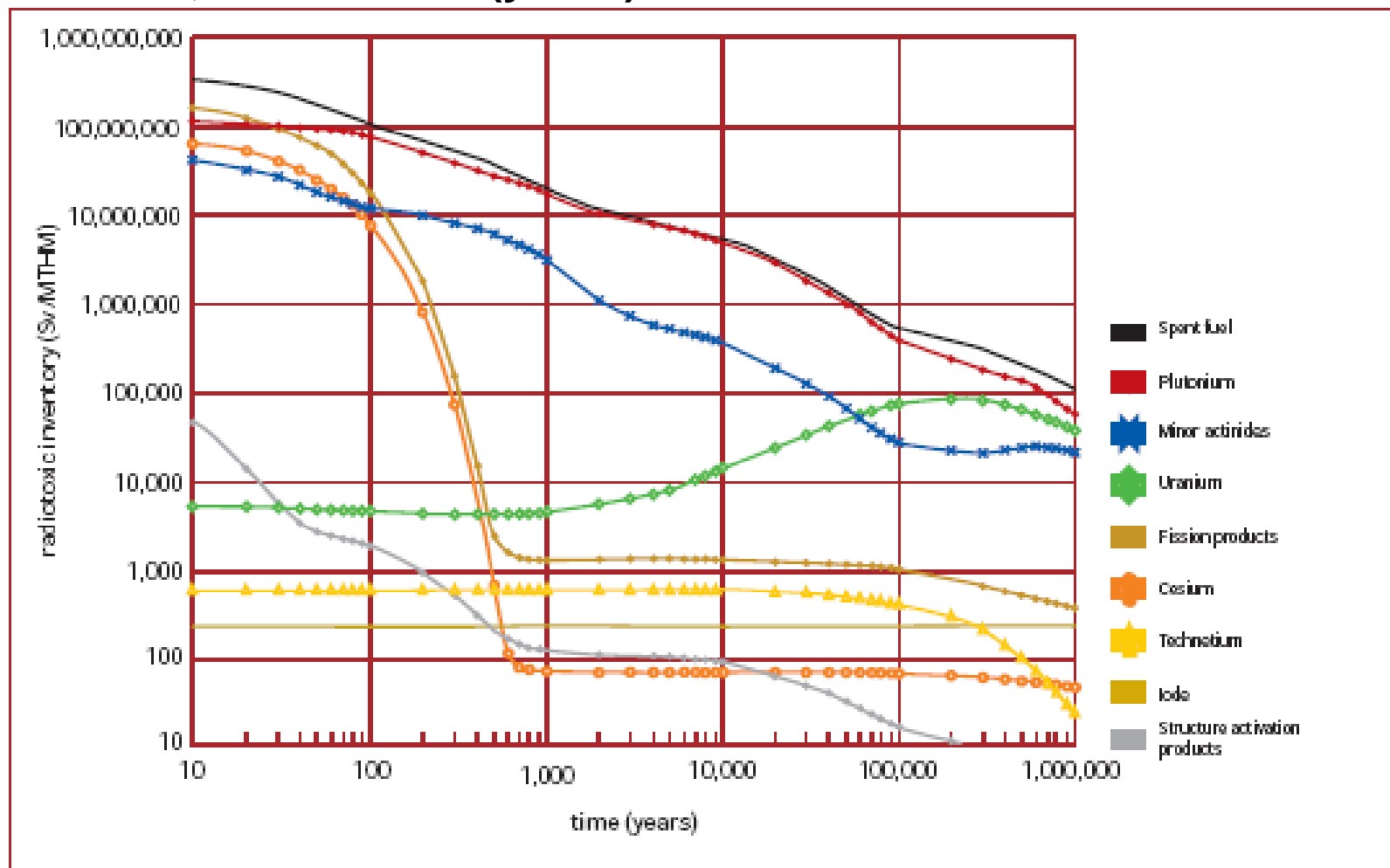

# What is Partitioning & Transmutation?

- Use of nuclear reactions to transform long lived nuclides into stable or short-lived nuclides (**transmutation**)
- Chemical separation of these nuclides from HLW is an inevitable ingredient for transmutation (**partitioning**)
- Objectives: Alleviation of the burden of a final disposal and minimization of long-lived nuclides in HLW

P/T applies to **TRU** (**Pu** and **Minor Actinides**) and **Long Lived Fission Products**. It should be kept in mind that **Plutonium** is a special case: it can be considered as a valuable resource or part of the wastes. However, **P/T technologies apply to the most general case.**

# A short historical perspective on Partitioning and transmutation (P/T)

## 40's to 70's: Pioneers

## 70's and 80's:

- Early Partitioning & Transmutation studies, mostly in Europe and in the US.

The physics is first explored together with some pioneering partitioning studies.

- Early studies on the impact of P/T on fuel cycle, P/T motivations, possible P/T „metrics“ for cost/benefits evaluation.

- Both IAEA and EURATOM did issue in the mid-eighties extensive reports with lukewarm conclusions: the challenge did seem to be formidable, without a clear strategy.

## **Late eighties- early nineties:**

- **The „OMEGA“ initiative in Japan, motivated by a strong public opinion concern about waste management. Japan requests OECD-Nuclear Energy Agency to organize international cooperation and information exchange in the field of P/T (first OECD-NEA Information Exchange meeting on P/T in 1990 at Mito, Japan. These conferences are still going on today, with a two years pace)**
- **At the same time in France, the waste management issue is discussed at the political level and a law is passed in 1991, in order to study possible strategies (including P/T) during a fifteen years period (1991-2006). A National Commission of Evaluation, appointed by the Government, is put in place.**
- **In the specific US context, the idea of a „Accelerator-driven Transmutation of Wastes (ATW)“ is launched at LANL, based on previous work.**

## Since early nineties:

■ International discussions on „metrics“ and motivations focus on the waste doses or „radiotoxicity“. This notion is controversial: Geologists and repository experts point out that the potential return to the bio-sphere of wastes is dominated by a few long lived fission product (like I-129), more mobile than Transuranics (Pigford). Moreover, the contribution to the dose after very long periods of time would be in any case very small.

■ However, safety experts point out that one has to consider not only scenarios of „normal“ evolution in time of the geological environment of the repository, but also „abnormal“ evolution scenarios, like human intrusion. These scenarios point out to the role of the „potential source“ of radiotoxicity (e.g. at ingestion), which is dominated by the TRU contribution.

■ Very significant resources are deployed in particular in Japan, in France (in particular in the field of partitioning, in order to achieve scientific demonstrations of feasibility of different separation processes) and in Europe, in the frame of successive R&D Framework Programs (these projects are focused on chemistry and on Accelerator Driven System-based transmutation). The AFCI program is started in the US.

■ More recently, there has been a key demonstration of the potential **beneficial effects** of Partitioning and Transmutation on a specific repository from the point of view of its design and operation, accounting for both **thermal constraints** and peak dose rate constraints.

• **A turning point ~2000: the objectives of GENERATION-IV do include P/T (waste minimization). P/T is seen from now on, as consistent with sustainability and non-proliferation objectives: it is the path towards “Advanced Fuel Cycles”.**



# A general scheme for advanced fuel cycles:

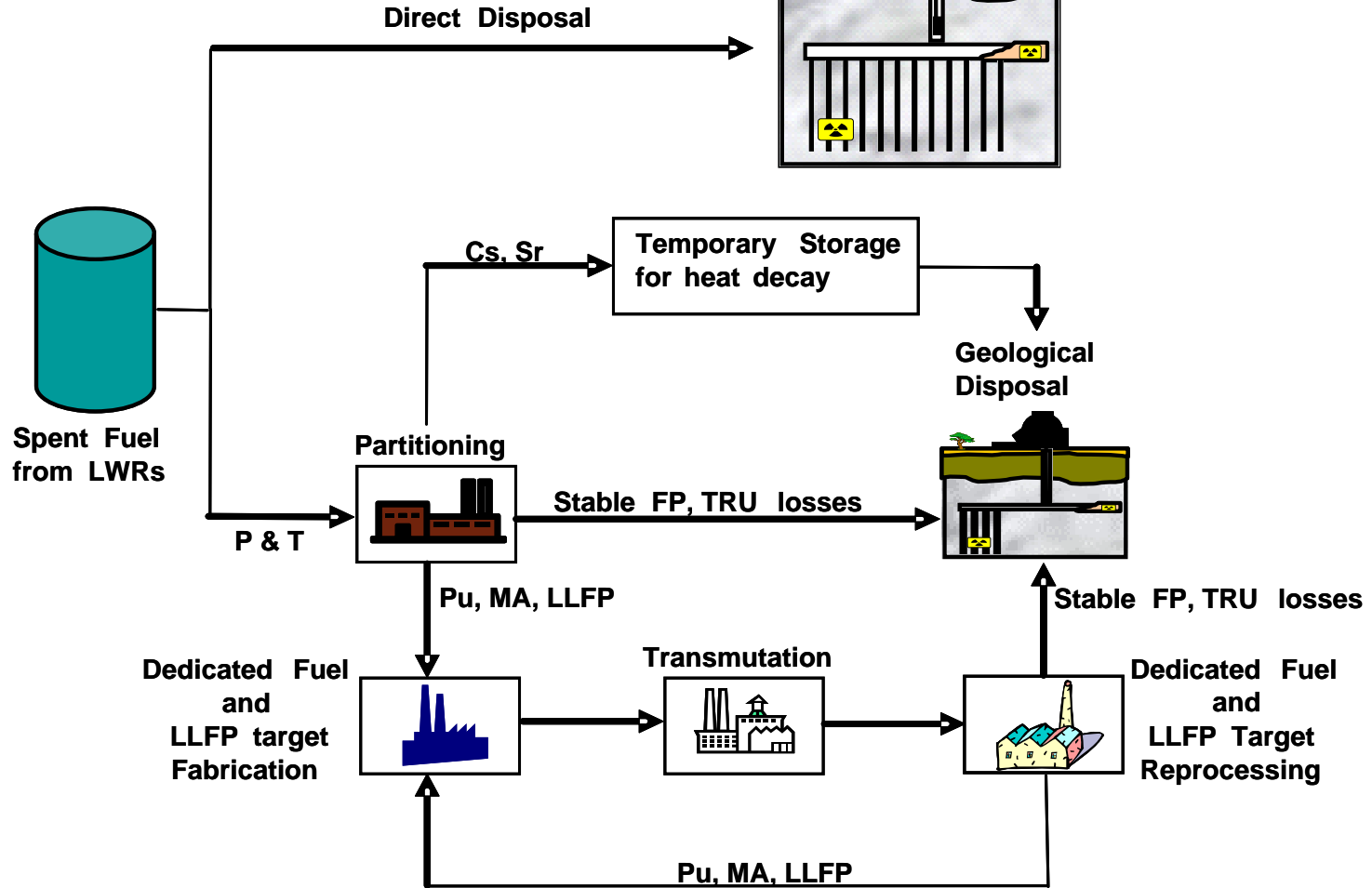

LLFP: Long lived fission products (Tc-99, I-129, Se -79, ...); MA: Minor Actinides (Am, Np, Cm)

# Nuclear reactions for transmutation of Long-lived nuclides

- Long-lived nuclides: Minor Actinides & some of LLFP
  - LLFP: FPs with half-life longer than 30 years such as  $^{99}\text{Tc}$  (half-life  $2 \times 10^5$  y),  $^{129}\text{I}$  (half-life  $1.6 \times 10^7$  y)
- Neutron reactions are the only reactions for effective transmutation of MA (neutron fission) and LLFP (neutron capture). However: for MA, neutron fission is always in competition with capture.
- Fast neutrons are best for MA transmutation:
  - Most MA have “threshold” fission (i.e. fission only at high neutron energy)
  - Thermal neutrons produce, via neutron capture, more high atomic number MA than cause fission of MA
  - More favourable fission-to-capture probability ratio with fast neutrons
- Thermal neutrons better for LLFP transmutation (higher capture probabilities) but transmutation rate is very slow. No major benefits, even if LLFP more “mobile” in geological environment.
- No effective means of transmutation of Sr-90, Cs-137 (half-lives ~30 yrs)

# Main features of fast neutron reactor physics:



Favorable neutron economy with respect to thermal neutron spectrum reactors:

Fission-to-Absorption Ratio for PWR and SFR

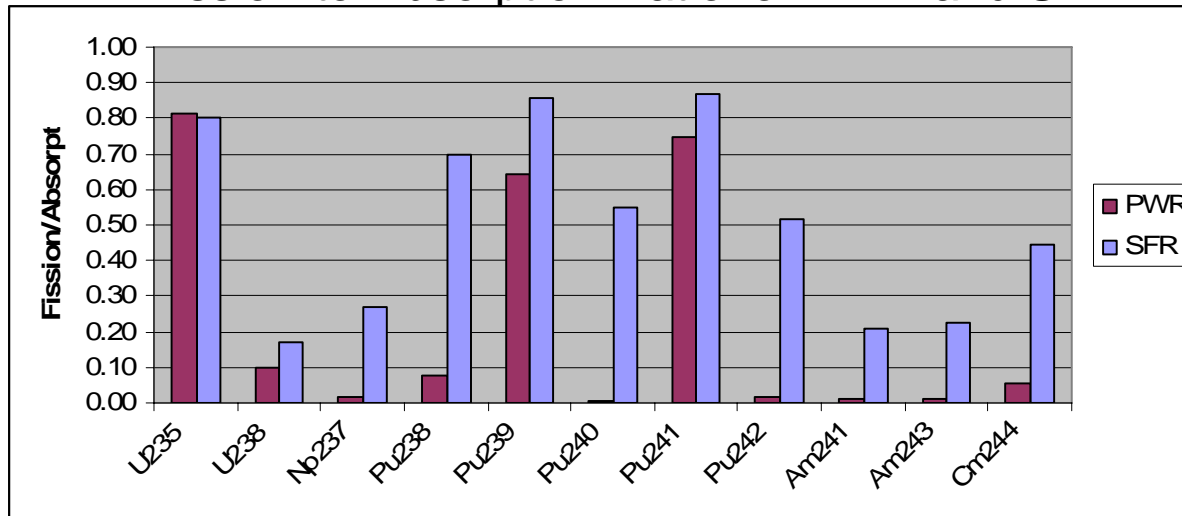

Fissile isotopes are likely to fission in both thermal/fast spectrum

However, the fission fraction is higher in fast spectrum

Moreover, significant (up to 50%) fission of fertile isotopes in a fast spectrum

**Net result is more excess neutrons and less higher actinide generation in FR**

## Three major scenarios to implement P/T:

- a) **Sustainable** development of nuclear energy with **waste minimisation**.  
One type of reactor, one fuel type, one reprocessing process
- b) **„Double strata“** fuel cycle: 1) commercial reactors with Pu utilisation 2) separate MA management. Two separate fuel cycles.
- ➔ The two previous scenarios imply the **continuous use of nuclear energy**, the **stabilisation of the TRU** stocks in the fuel cycle and the **minimisation of wastes** in a repository.
- c) **Reduction of TRU stockpiles** (e.g. as a legacy from the past operation of power plants)
- ➔ **All three scenarios** go beyond the strategy of „once-through“ („open“) fuel cycle (i.e. the final storage of irradiated fuel), and **imply fuel reprocessing**.



## Scenario a) : Why not **Thermal** instead of **Fast** Reactors?

Consequences on fuel cycle parameters of full TRU recycling in LWRs, e.g. at fuel fabrication:

| Parameter      | Multiplying factor <sup>(a)</sup> |
|----------------|-----------------------------------|
| Activity       | ~0.5                              |
| $\alpha$ -heat | ~ 3                               |
| $\beta$ -heat  | ~ 0.5                             |
| $\gamma$ -heat | ~ 3.5                             |
| neutron source | ~ 8000                            |

- Unacceptably high – Effect due to high capture cross-sections in thermal spectra, which favour.. Cf-252 production !

<sup>(a)</sup>Reference value (=1): case of Pu-only multirecycling

## Scenario b) « Double strata »: Pu still a resource. Gen-IV FR deployment delayed

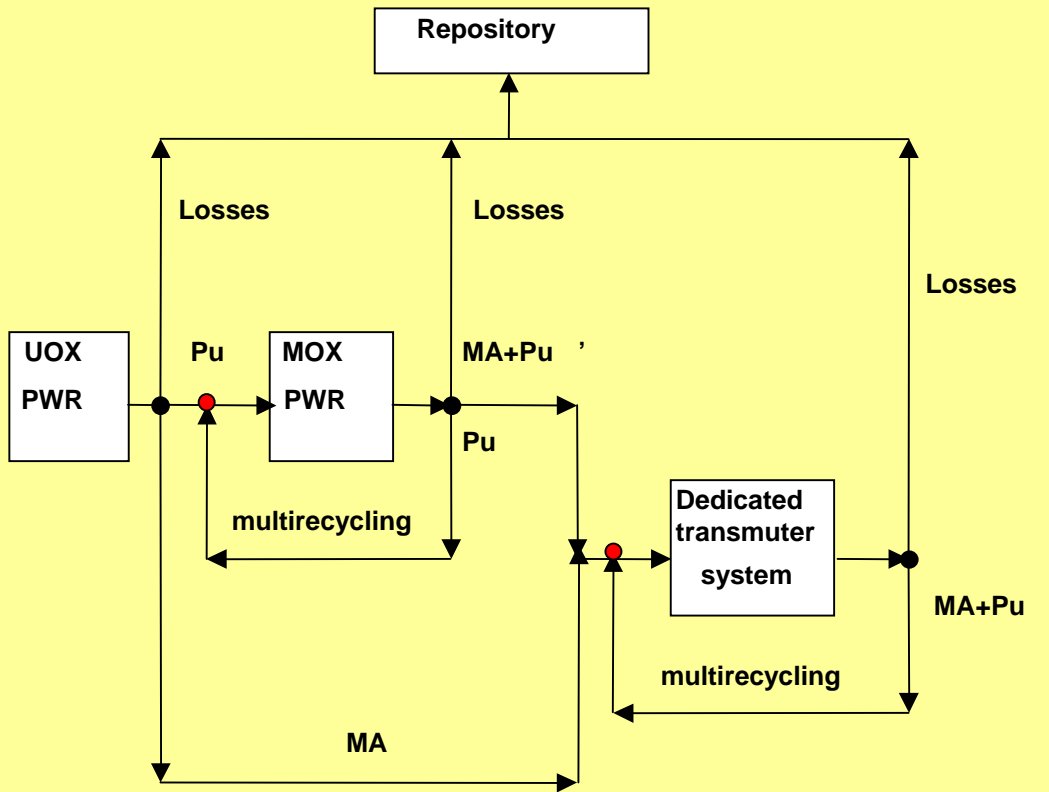

● Fuel fabrication

● Reprocessing

➔ The Pu inventory can be stabilized.

➔ MA management in dedicated transmuter systems:  
1) critical Fast Reactors, or 2) subcritical **A**ccelerator **D**riven **S**ystems (**ADS**) with U-free fuel

➔ New fuel (with high MA content).  
If U-free, inert matrix.  
New fabrication processes.

➔ Reprocessing: to be developed, in particular for U-free fuels. Choice of support matrix in the fuel is relevant. Adequacy of aqueous processes? Use of pyrochemistry?

➔ The “**support**” ratio, i.e. the ratio of the total power of the dedicated systems to the total power of the power generating systems is of the order of **6 %**.

## Scenario c): Reduction of Pu+MA stockpile (Pu considered as waste)

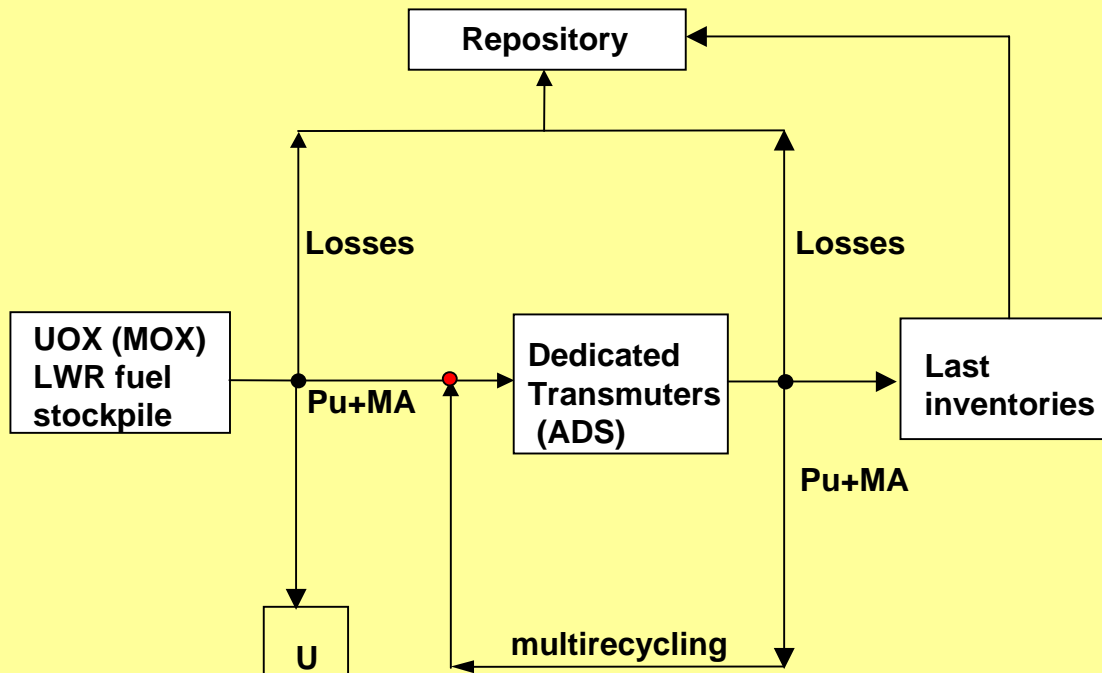

- ➡ Limited number of dedicated transmuters: need to account for last transmuter in-core inventories
- ➡ Fuel in the dedicated transmuter: Pu/MA ~ 80/20 to be developed. New fabrication processes needed.
- ➡ Reprocessing of transmuter fuel: to be developed. Adequacy of aqueous methods? Pyrochemical processes? Secondary wastes.

● Fuel fabrication

● Reprocessing

**If timeframe for reducing stockpile ~100 y, ~20% of initial stockpile is not burnt.**



# Potential benefits of P/T

P/T offers significant potential benefits to the fuel cycle:

- Reduction of the potential source of radiotoxicity in a deep geological storage („intrusion“ scenario)
- Reduction of the heat load: larger amount of wastes can be stored in the same repository
- If TRU are not separated (e.g. in the homogeneous recycling in a Fast Neutron Reactor), improved proliferation resistance is expected

# Radiotoxicity reduction

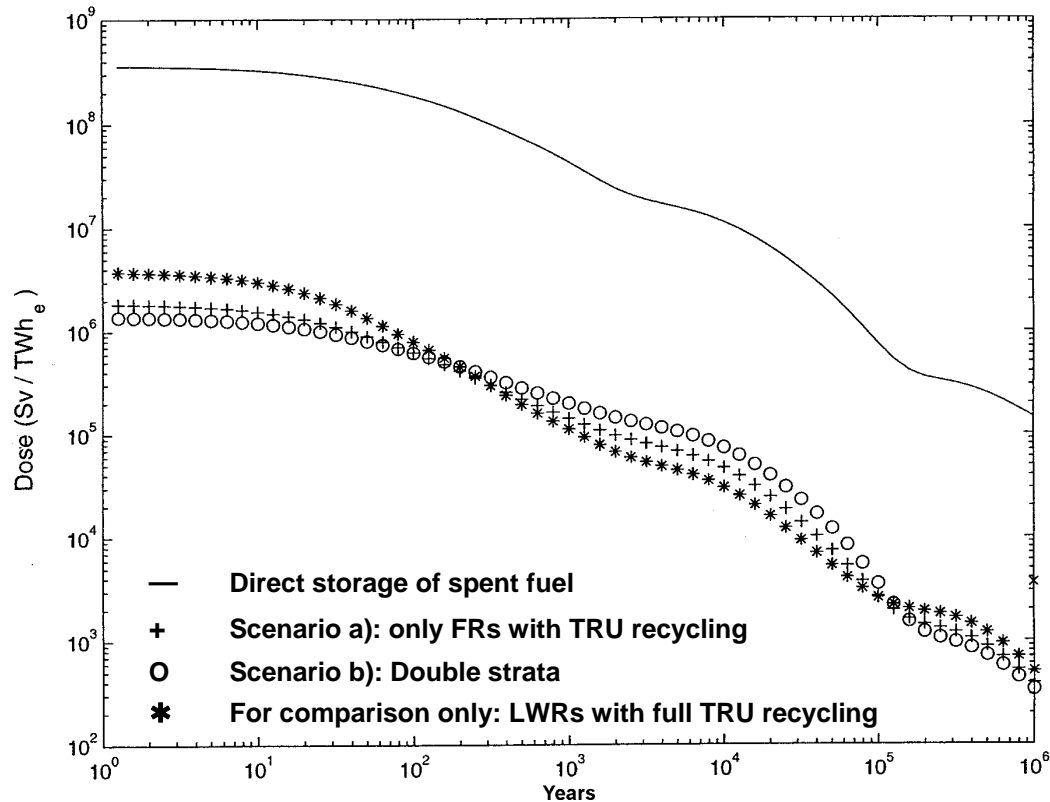

- Radiotoxicity reduction is comparable (i.e. higher than a factor 100) in transmutation scenarios a) and b), and depends on losses during reprocessing. In the cases presented here a 0.1 % value is taken for all TRU.
- However, the impact on the fuel cycle is different. It becomes unacceptably high if all TRU recycled in LWRs, due to the high neutron doses at fuel fabrication (as shown previously).

# Potential Benefits of a Closed Fuel Cycle (P/T) based on Fast Reactors for Waste Management

- Certain elements (plutonium, americium, cesium, strontium, and curium) are primarily responsible for the decay heat that can cause repository temperature limits to be reached
- Large gains in repository space are possible by processing spent nuclear fuel to remove those elements

## The recovered elements must be treated:

- Cesium and strontium can be stored separately for 200-300 years
- Plutonium, americium, and curium can be recycled for transmutation and/or fission by irradiation in fast reactors

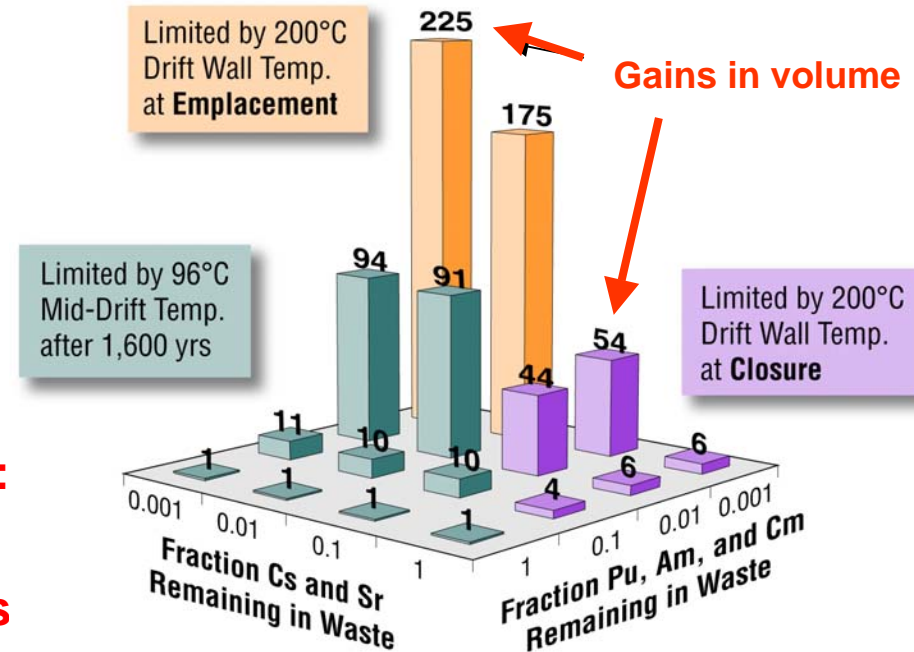

# Critical Technology Issues

Need to be informed by scientific knowledge and industrial practices

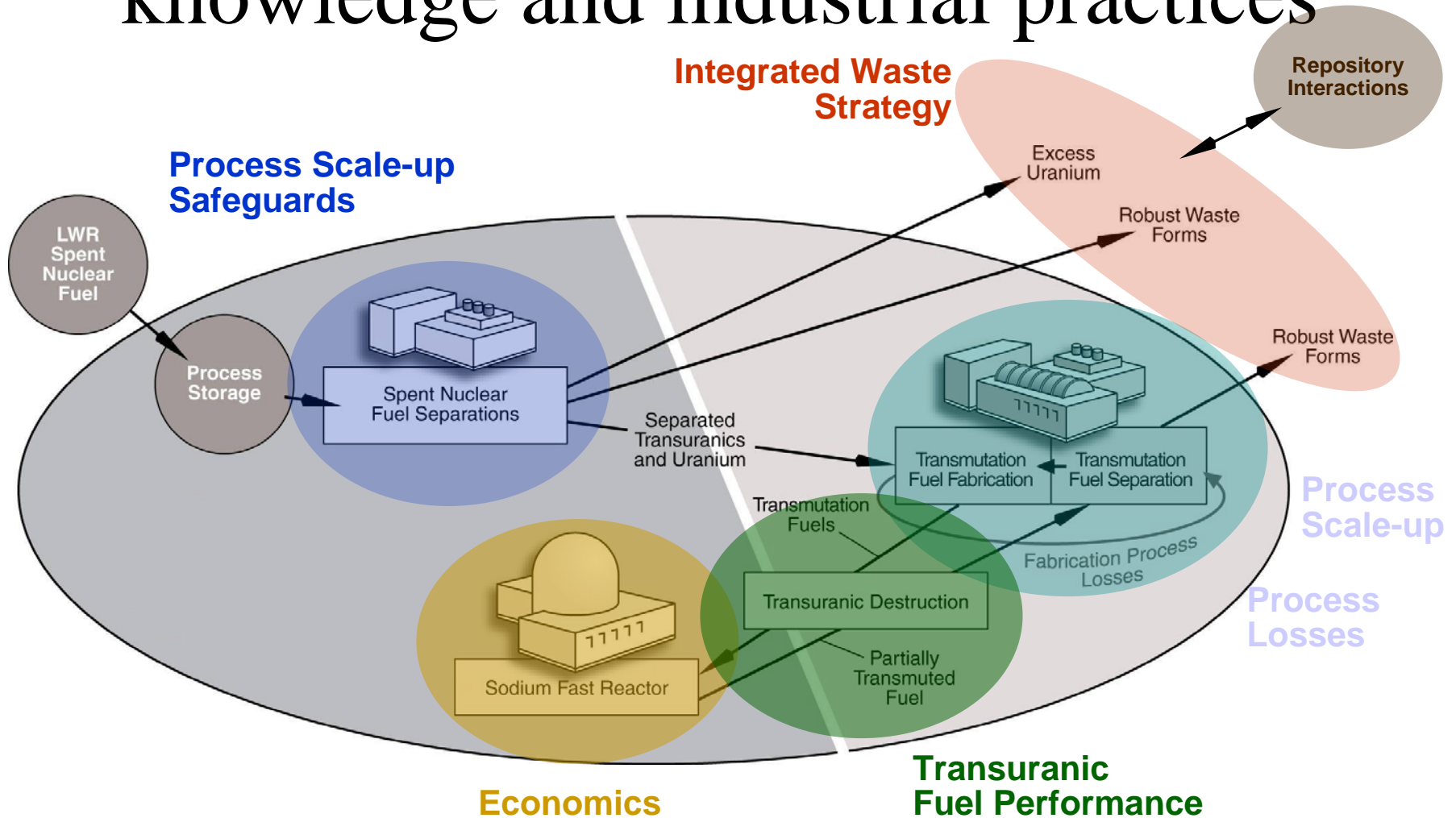

# Technical challenges to Actinide Separations

- ✓ **Chemistry of actinides is complex: actinides form multiple valence states, similar to that of lanthanides**
- ✓ **„Grouped“ separation of TRU**
- ✓ **Process losses reduction**
- ✓ **Production and management of the secondary wastes**
- ✓ **Cost reductions**

**Aqueous and Dry (pyrochemical) processes can be used and are developed**

# Chemistry....

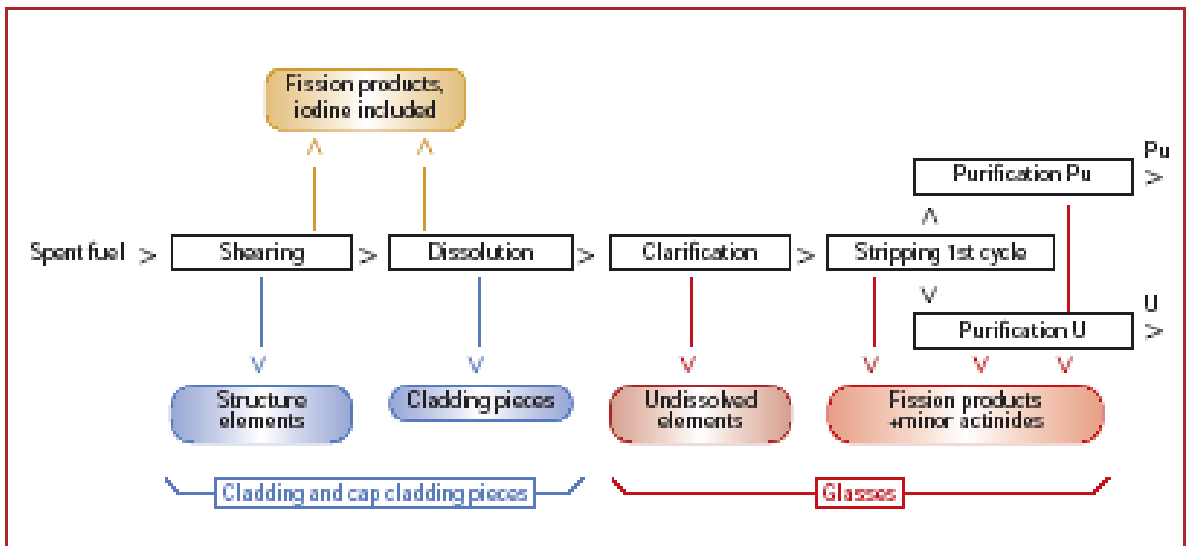

Figure C.1: basic diagram of the Purex process.

In France, significant developments to go from the PUREX process of today...

...to enhanced partitioning scheme and their demonstration:

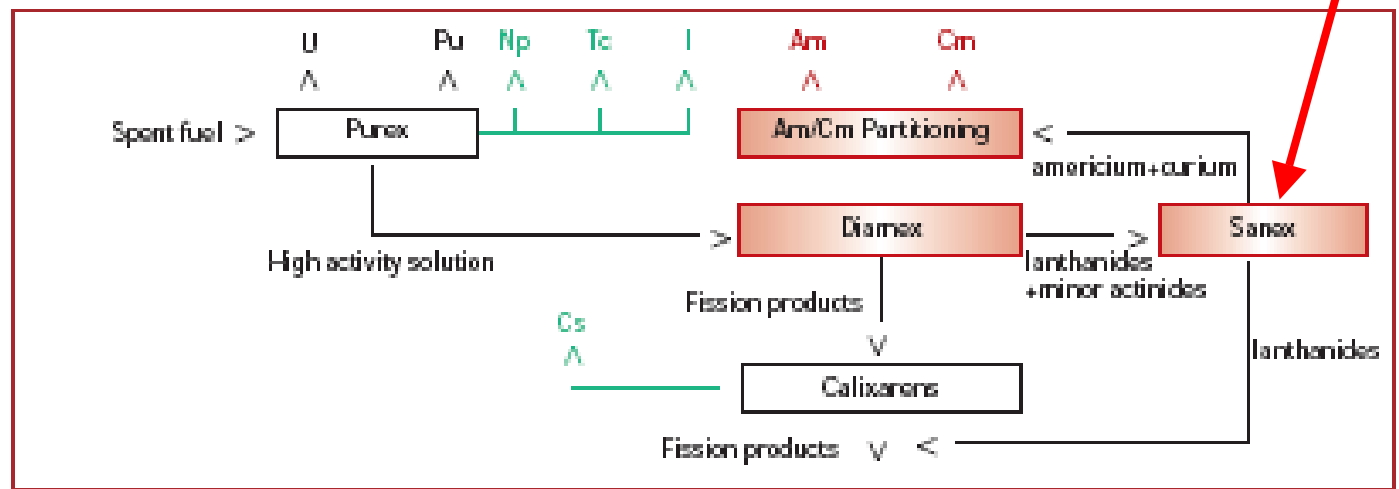
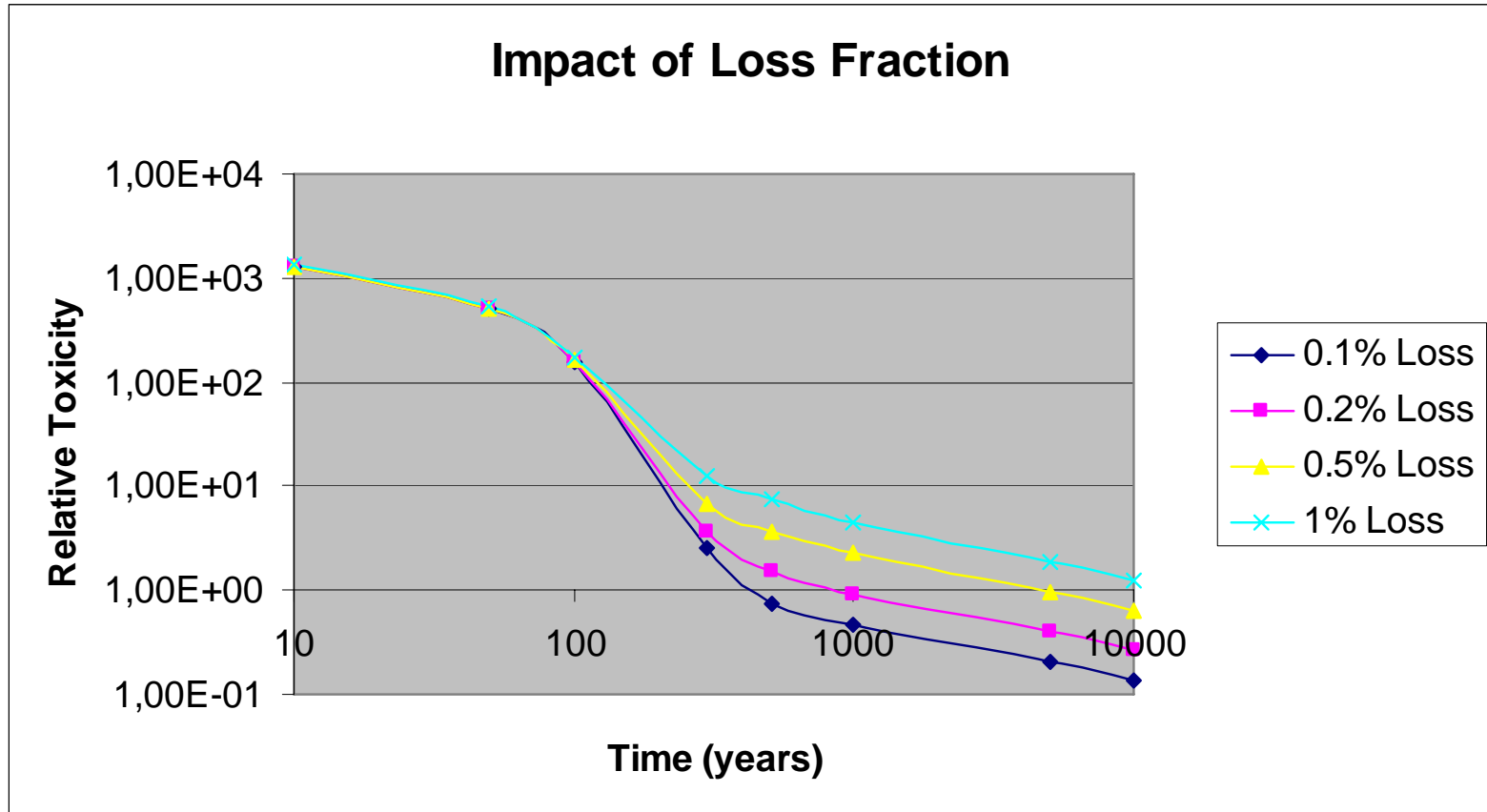

Figure C.2: enhanced partitioning scheme.

# Importance of Processing Loss Fraction



**Radiotoxicity goal cannot be achieved if loss fraction increases beyond 0.2%, and extends to 10,000 years at 1% losses**

## Technical challenges to Fuel Development

- ✓ Large decay heat and high neutron emission of MA give new problems with respect to standard fuel manufacturing
- ✓ However problems are smaller if the fuel contains U and small amount of MA (as in the case of scenario a) with respect to U-free fuels (as in the case of scenario b) and c)) with large amounts of MA.
- ✓ In the case of U-free fuels, the choice of the support/matrix (e.g. for oxide fuels: MgO, ZrO<sub>2</sub>, Mo...) is crucial for a good thermal behaviour under irradiation.
- ✓ Fabrication processes are challenging (avoid contamination etc.), in particular for a significant content of Cm.
- ✓ In any case, remote handling is needed



# ADS demonstration:

In Europe, a series of demonstrations of separate **ADS** components, has been performed:

The physics of the sub critical core.....

A 1MW liquid LBE spallation target....

Some crucial components of a high intensity proton accelerator.....

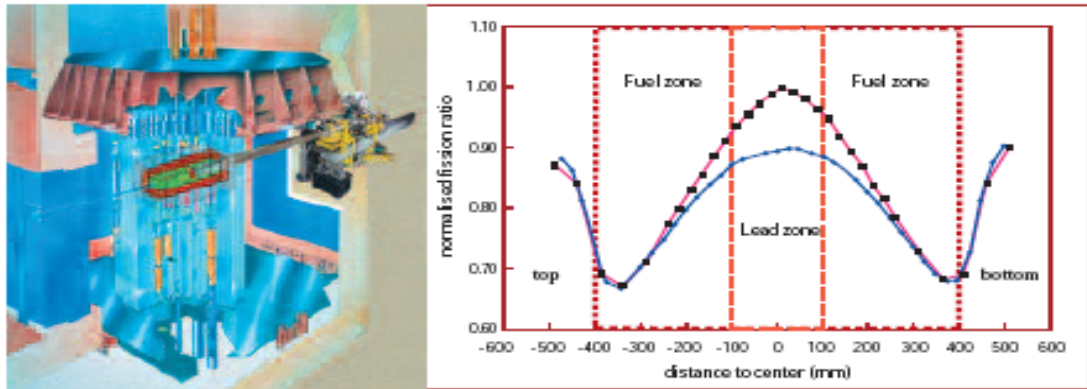

Figure D.8: Muse ADS experiment with the Masurca reactor and the Genevi accelerator; system power along a reactor section cross line (in blue: critical core without source, in red: subcritical mode with source).

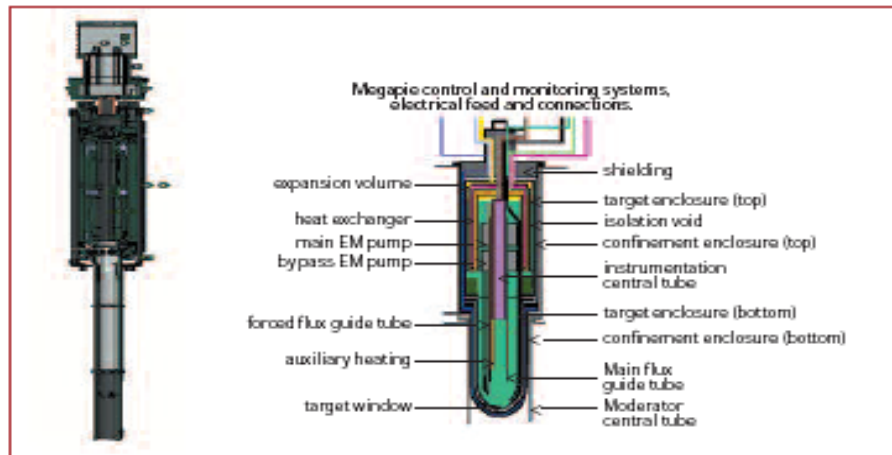

Figure D.9: Megapic spallation target (left: global view, right: detailed view).

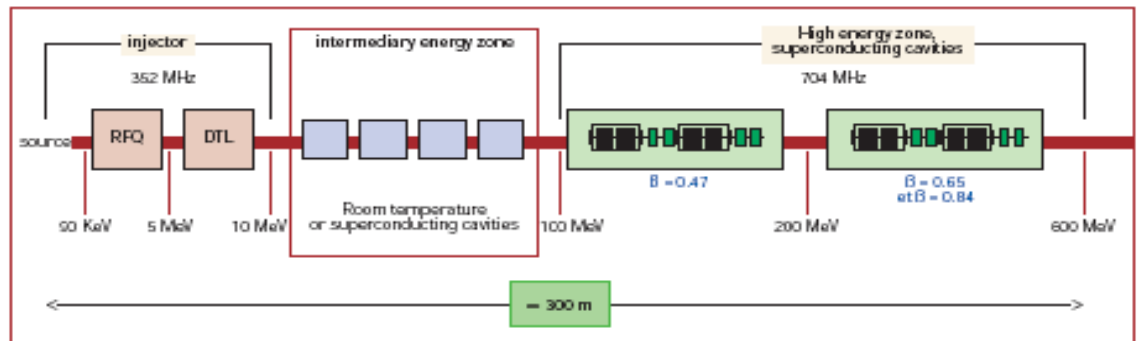
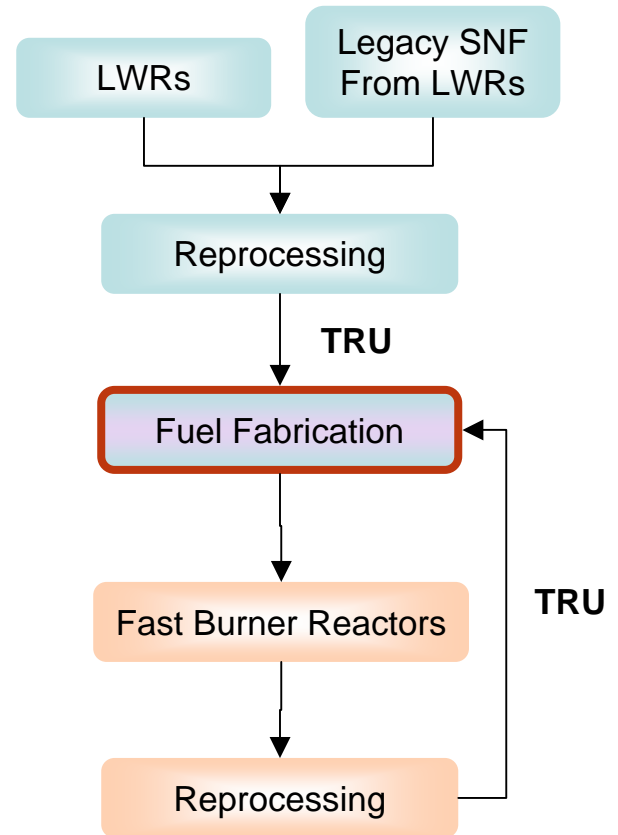

Figure D.10: scheme of an ADS linear accelerator.

# Transmutation fuel development is considerably more challenging than conventional fuels

- Multiple elements in the fuel  
U, Pu, Np, Am, Cm
- Varying thermodynamic properties  
e.g. High vapor pressure of Am
- Impurities from separation process  
e.g. High lanthanide carryover
- High burnup requirements
- High helium production during irradiation
- Remote fabrication & quality control
- **Fuel must be qualified for a variable range of composition**
  - Age and burnup of LWR SNF
  - Changes through multiple passes in FR
  - Variable conversion ratio for FR



TRU bearing metal and oxide fuels have demonstrated performance and feasibility to ~6 at% and current testing will extend this to ~15 to 20 at%.

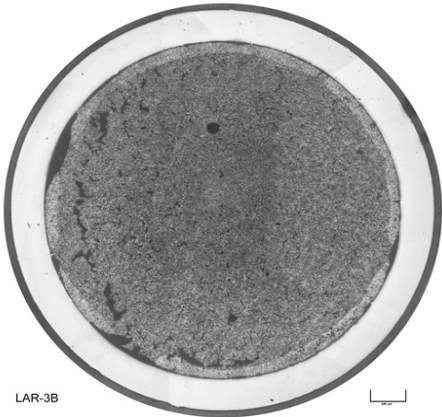

6.0 at%  
 $6.8 \times 10^{20}$  f/cm<sup>3</sup>

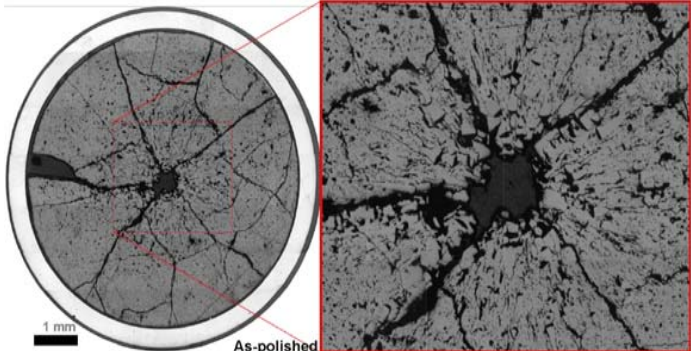

• 5%Am-MOX, • O/M:1.98  
• Core center elevation

**Metals** – performance similar to (U, Pu, Zr) and the onset of swelling at higher burnup than conventional (U, Pu, Zr)

**Oxides** - performance and microstructure develops similar to conventional MOX.



**Nitrides** - have had difficulty with consistent fabrication but have performed as expected under irradiation.

# Cost Evaluations for Advanced Fuel Cycles

- Cost evaluations for advanced fuel cycles (including P/T) have been recently performed in the frame of two different OECD-NEA working groups.
- In particular, cost evaluations have been performed for the two major strategies for implementing P/T, i.e. the „double strata“, where ADS multi-recycle MA, and the full recycling of not-separated TRU in fast reactors.
- The increase in electricity cost due to advanced fuel cycles, has been found to be “relatively” limited (10% to 20%) compared to the once through fuel cycle
- However the authors of the studies underline the uncertainties associated to these evaluations.
- Moreover technical uncertainties on some innovative techniques, their feasibility and performance should be accounted for.

# Cost Evaluations for Advanced Fuel Cycles

Reference: Advanced Fuel Cycles and Waste Management. OECD/NEA Publication.

RCOST (%)

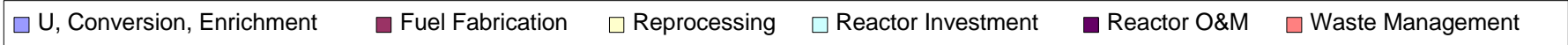
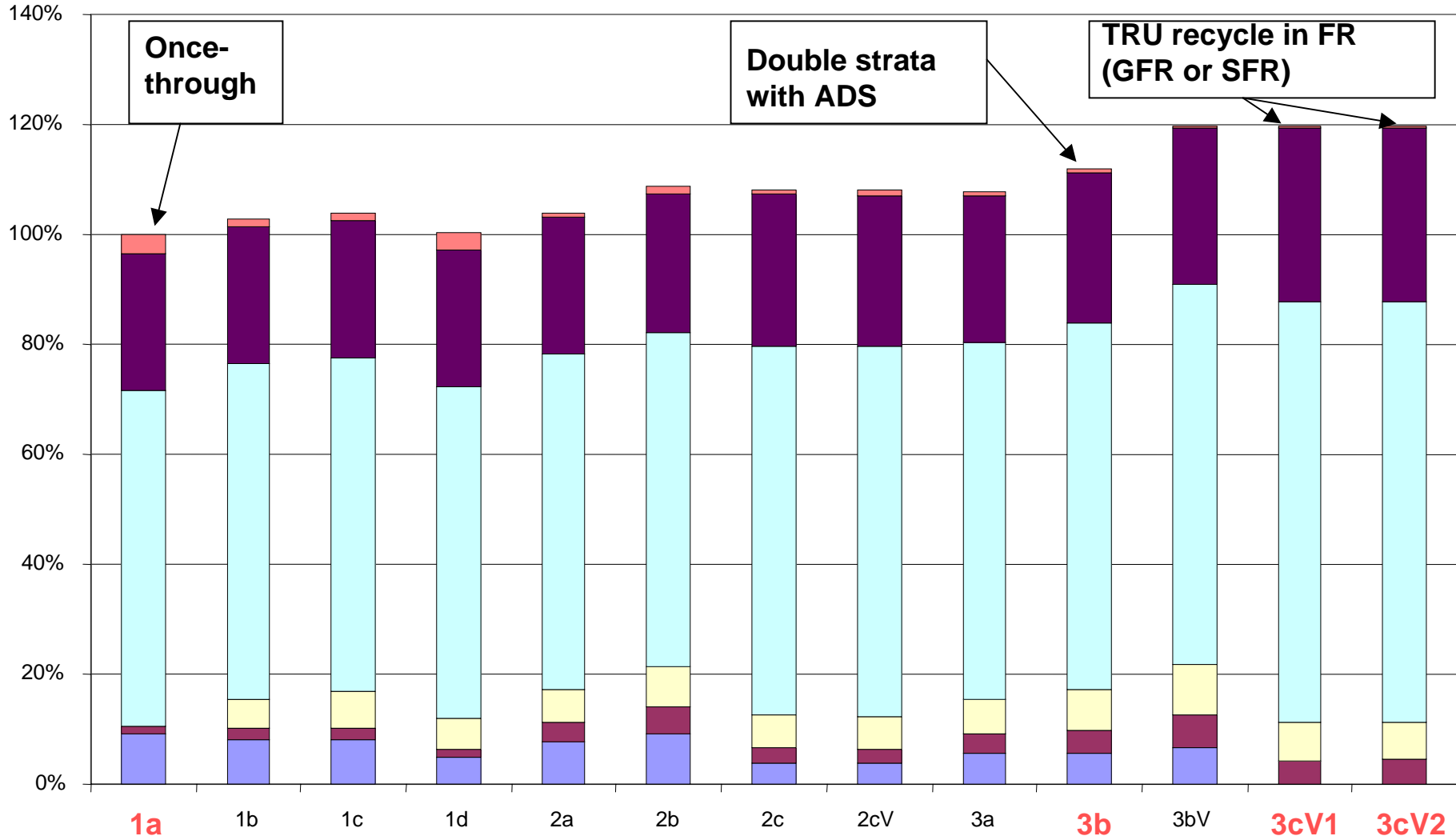

# Implementation Issues

- Ownership and investment strategies
- Maturity of R&D
- Long deployment times
- Availability of repositories
- Need to adapt regulations and regulatory regimes
- Public perception
  - All suggest evolutionary rather than revolutionary scenarios

# Conclusions

- P/T technologies offer the potential for a significant radioactive waste minimisation
- P/T can be applied to widely different fuel cycle strategies:
  - Sustainable development of nuclear energy**
  - Minimisation of the waste arising from a legacy of spent nuclear fuel**
- P/T **does not** eliminate the need for a deep geological storage whatever the strategy **but** allows to increase its capacity, to reduce drastically the burden on it and improve public acceptance
- Fast Reactors offer the most flexible tool in order to implement P/T: The results of the studies clearly indicate a consensus on the fact that to reach the optimum performances of P/T, fast spectrum reactors and fully closed fuel cycles are needed, together with chemical processes which allow reaching ~99.9% recovery of all TRU.
- Demonstration of P/T implies the demonstration of all the “building blocks”: adapted fuels, adapted reprocessing techniques, reactor loaded with significant quantities of MA
- LLFP transmutation is questionable. However the Cs and Sr management is a relevant issue.