

Citation:

KNAW, Proceedings, edition 19 I, 1917, volume

6611 f

KONINKLIJKE AKADEMIE
VAN WETENSCHAPPEN
-:- TE AMSTERDAM -:-

PROCEEDINGS OF THE
SECTION OF SCIENCES

VOLUME XIX
(— 1ST PART —)
— (N^o. 1—5) —



JOHANNES MÜLLER :—: AMSTERDAM
:=====: MARCH 1917 :=====:

(Translated from: Verslagen van de Gewone Vergaderingen der Wis- en
Natuurkundige Afdeling XXIII XXIV and Dl. XXV.)

KONINKLIJKE AKADEMIE VAN WETENSCHAPPEN
TE AMSTERDAM.

PROCEEDINGS

VOLUME XIX

Nº. 1.

President: Prof. H. A. LORENTZ.

Secretary: Prof. P. ZEEMAN.

(Translated from: "Verslag van de gewone vergaderingen der Wis- en
Natuurkundige Afdeling," Vol. XXIV and XXV).

CONTENTS.

- J. J. VAN LAAR: "On the Fundamental Values of the Quantities b and $1/a$ for Different Elements, in Connection with the Periodic System II. Mercury and Antimony. General Methods", p. 2.
- A. SCHIERBEEK: "On the Setal Pattern of Caterpillars." (Communicated by Prof. J. F. VAN BEMMELEN), p. 24.
- Mrs. C. E. DROOGLEEVER FORTUYN—VAN LEIJDEN: "Some Observations on Periodic Nuclear Division in the Cat." (Communicated by Prof. J. BOEKE), p. 38.
- H. ZWAARDEMAKER, H. R. KNOOPS and M. W. VAN DER BIJL: "The electrical phenomenon in cloud-like condensed odorous water vapours", p. 44.
- H. M. DE BURLET and J. I. J. KOSTER: "On the determination of the position of the maculaplanes and the planes of the semicircular canals in the cranium". (Communicated by Prof. H. ZWAARDEMAKER), p. 49.
- Miss E. TALMA: "The influence of temperature on the growth of the roots of *Lepidium sativum*." (Communicated by Prof. F. A. F. C. WENT), p. 61.
- C. DE JONG: "Determination of the constant of Precession and of the Systematic Proper motions of the stars, by the comparison of KÜSTNER's catalogue of 10663 stars with some zone-catalogues of the "Astronomische Gesellschaft" (Communicated by Prof. E. F. VAN DE SANDE BAKHUYZEN) p. 65.
- JAN DE VRIES: "Pencils of twisted cubics on a cubic surface", p. 97.
- T. P. FEENSTRA: "A new group of antagonizing atoms". I. (Communicated by Prof. H. ZWAARDEMAKER), p. 99.
- D. J. HULSHOFF POL: "The relation of the plis de passage of GRATIOLET to the ape fissure." (Communicated by Prof. C. WINKLER), p. 104.
- H. J. HAMBURGER: "Quantitative determination of slight quantities of SO_4 . II. Contribution to microvolumetrical analysis", p. 115.
- P. ZEEMAN: "Direct optical measurement of the velocity at the axis in the apparatus for FIZEAU's experiment", p. 125.
- A. SMITS and A. H. W. ATEN: "The Application of the Theory of Allotropy to Electromotive Equilibria." V. (Communicated by Prof. J. D. VAN DER WAALS), p. 133.
- J. D. R. SCHEFFER and F. E. C. SCHEFFER: "On Diffusion in Solutions." I. (Communicated by Prof. A. F. HOLLEMAN), p. 148.
- V. WILLEM: "The movements of the heart and the pulmonary respiration with spiders." (Communicated by Prof. G. VAN RIJNBERK), p. 162.
- A. A. GRÜNBAUM: "On the nature and progress of visual fatigue." (Communicated by Prof. G. VAN RIJNBERK), p. 167.
- W. REINDERS: "The system Iron-Carbon-Oxygen." (Communicated by Prof. J. BÖESEKEN), p. 175.
- W. REINDERS: "Birefractive colloidal solutions." (Communicated by Prof. J. BÖESEKEN), p. 189.
- J. DROSTE: "The field of a single centre in EINSTEIN's theory of gravitation, and the motion of a particle in that field." (Communicated by Prof. H. A. LORENTZ), p. 197.
- H. J. WATERMAN: "The Metabolism of *Aspergillus niger*." (Communicated by Prof. J. BÖESEKEN), p. 215.
- D. J. HULSHOFF POL: "The ape fissure — sulcus lunatus — in man." (Communicated by Prof. C. WINKLER), p. 219.
- BALTH. VAN DER POL Jr.: "The currents arising in n-coupled circuits when the primary current is suddenly broken or completed." (Communicated by Prof. W. H. JULIUS), p. 225.

1

Proceedings Royal Acad. Amsterdam. Vol. XIX.

Physics. — “On the Fundamental Values of the Quantities b and \sqrt{a} for Different Elements, in Connection with the Periodic System II. Mercury and Antimonium. General Methods”. By Dr. J. J. VAN LAAR. (Communicated by Prof. H. A. LORENTZ).

(Communicated in the meeting of March 25, 1916).

I. In our foregoing paper¹⁾ we have found that the values of b and \sqrt{a} at the critical temperature can be built up *additively* from a few constant, *fundamental values* for the different elements. (See the tables on p. 1223 and p. 1229 of the cited paper). The elements H, C, N, and O presented in this, as far as the values of b are concerned, two different fundamental values (H even three), of which the second may be considered as a *contraction* — about in the ratio of $\frac{1}{2}\sqrt{2} \cdot 1$ — of the fundamental value. [For H the third value is to the first as $(1 - \frac{1}{2}\sqrt{2}) : 1$]. The way in which these multiple values must be used in the *reconstruction* of the values of b and \sqrt{a} of the different chemical combinations has been sufficiently set forth in the first paper (henceforth to be indicated by I). (See the different tables and the summary on p. 1234). With regard to the values of \sqrt{a} we should pay attention to the fact that for compounds as CH_4 , CCl_4 , CH_3Cl , CHCl_3 , C_2H_6 , etc., and also for NH_3 and PH_3 , GeCl_4 and SnCl_4 , the *central* atoms do *not* take part in the attraction; so that in the reconstruction the values of \sqrt{a} for C, N, P, Ge, Sn must all be put = 0. But for doubly bound C half the value $C = 1,55$ is found, and for the triply bound C the full value 3,1. (see further again the tables, and also p. 1220—1221 and 1235; also with regard to the two values for H).

Below we reproduce the two principal tables²⁾.

Fundamental Values for $b_k \times 10^5$.

H = 48,5 (34;14)	C = 100 (75)	N = 85 (60)	O = 70 (50)	F = 55	He = 105?
	(Si = 155)	P = 140	S = 125	Cl = 115	Ne = 71?
	Ge = 210	(As = 195)	Se = 180	Br = 165	Ar = 144
	Sn = 265	Sb = 250	(Te = 235)	I = 220	Kr = 177
					X = 228

¹⁾ These Proc. of Jan. 29, 1916.

²⁾ In the table for \sqrt{a} on p. 1229 $\text{Ne} = 6,3 \times 10^{-2}$ [= $\sqrt{39,6 \times 10^{-2}}$] has been written instead of $\text{Ne} = 2,0 \times 10^{-2}$ [= $\sqrt{3,96 \times 10^{-4}}$]. Correct further on p. 1224: H_2 found = 97⁵ instead of 97; on p. 1229: H_2 found = 1,96 instead of 1,95; on p. 1237 read: neutralized in ordinary circumstances; “closed”, as M. expresses himself — would be free and “open”.

In every *vertical* column the increase is therefore 55 units, while in every *horizontal* row the decrease amounts to 15 units. The values for Si, As, and Te, which we have placed between parentheses, could not be verified as yet by known compounds, the critical data of them being imperfectly known.

Fundamental Values for $\sqrt{a_k} \times 10^2$.

H = 3,2 (1,6)	C = 3,1	N = 2,9	O = 2,7	F = 2,9?	He = 0,8?
—	—	P = 6,4	S = 6,3	Cl = 5,4	Ne = 2,0?
—	—	—	Se = 7,1	Br = 6,9	Ar = 5,2
—	—	Sb = 8,9	—	I = 8,8	Kr = 6,9
					X = 9,1

If we add to this $Hg = 11,0$, as we shall immediately find, it may be said that in the different horizontal principal series of the periodic system the values of \sqrt{a} are very nearly constant, the ratio in round numbers being (taking $He = 1$)

$$1 : 3 : 5 \cdot 7 \cdot 9 : 11.$$

We add that the values of b in the column of the halogens are in exactly the same ratio as the values 1 . 2 . 3 . 4 (taking $Cl = 110$).

II. Before proceeding to the calculation of some new fundamental values — in which some methods will be discussed for the calculation of the values of a and b for substances where T_k and p_k are unknown, and besides of the unknown values of T_k and p_k themselves — we will make a few general remarks.

In the first place we draw attention to this, that when the above tables are used to calculate the critical temperature and pressure for *elements*, the critical data of which are unknown as yet, the *molecular state* of these elements at T_k must be taken into account.

Thus at the critical temperature mercury has long become Hg_2 . Only at lower temperatures the mercuryvapour is $= Hg_1$ on account of the great volume, as is known. But at higher temperatures, where the vapourvolume gets smaller and smaller, the association to Hg_2 increases more and more, and is almost complete at T_k . For mercury, namely, just as for some other associating substances the increase of volume of the vapour triumphs on the *decrease* of temperature, and therefore the association does not increase, but *decreases*. The same thing is probably the case for water, but for this substance the association at T_k (of the vapour namely) is still slight,

1*

while for mercury it is complete. To this case belong those substances, for which the heat of dissociation q of the double molecules (i.e. the absorbed heat in dissociation) is comparatively small or $= 0$ (at any rate $< fT_k$; hence for ordinary substances $< 7 T_k$, when q is expressed in gr. cal.). Acetic acid belongs to the other category of substances, for which the association in the vapour decreases on increase of temperature, till a minimum is reached in the neighbourhood of T_k . At still higher temperature the association in the vapour increases again. Here (below the temperature of inversion) the temperature-change therefore prevails over the volume-change. To this belong those substances, for which the heat of dissociation of the double molecules is comparatively large ($> 7 T_k$).

Accordingly mercury — and we shall also see this confirmed on other grounds — is *bimolecular* at T_k .

Now $RT_k = \frac{8}{27} \lambda \frac{a_k}{b_k}$, $p_k = \frac{1}{27} \lambda \frac{a_k}{b_k^2}$, in which λ for substances with high critical temperature has the limiting value $27/2$,¹⁾ so that with $R = 1:273,1$ we have:

$$T_k = 78,03 \frac{a_k}{b_k} \quad ; \quad p_k = \frac{1}{28} \frac{a_k}{b_k^2}$$

If now $(\sqrt{a_k})_1 = 11,0 \times 10^{-2}$; $(b_k)_1 = 150 \times 10^{-5}$ for Hg_1 , as we shall find presently, then we get for Hg_n :

$$T_k = 78,03 n \frac{121}{150} \times 10^1 \quad ; \quad p_k = \frac{1}{28} \frac{121}{225} \times 10^4$$

because for Hg_n $\sqrt{a_k} = n(\sqrt{a_k})_1$, and also b_k will be $= n(b_k)_1$ (possible contraction for b_k excluded).

Hence we find:

$$T_k = n \cdot 630^\circ \text{ (abs.)} \quad ; \quad p_k = 192 \text{ atm.}$$

And as the critical temperature of mercury (see § 3) is lying with great probability in the neighbourhood of 1260° (absolute)²⁾, and

1) For λ we have namely found the expression $\lambda = \frac{27}{8\gamma-1} \left(\frac{\gamma}{\gamma+1} \right)^2$, in which

γ (the reduced coefficient of direction of the straight line between D_k and D_0 in a D, T -diagram, i. e. of the ideal "straight diameter") verges to 1. (Cf. These Proc. of March 26, 1914, p. 88, formula (18)).

2) Not in all the tables Celsius degrees are distinguished from absolute temperatures with sufficient care in records of temperatures. Thus e.g. in the "*Tables annuelles*" (which contain many errors also in other respects), I find continually amidst records of temperatures in Celsius degrees, values which are meant in absolute temperature, *without this being stated*. For the critical temperature of mercury I found the value $\pm 1270^\circ$ C., given somewhere in those tables. The value is correct, but the addition: degrees Celsius is faulty. For then T_k would be about 1540° absolute, whereas in reality $T_k = 1260^\circ$ absolute.

p_k being about 200 atm., we find [besides total absence of any contraction of the b -value in the dissociation of Hg_2 , i. e. $(b_k)_2 = 2 \times (b_k)_1$] a value for n which differs but very little from 2.

For *Antimonium*, where $(\sqrt{a_k})_1 = 8,9 \times 10^{-2}$ and $(b_k)_1 = 250 \times 10^{-5}$, we should find on the supposition of Sb_1 at T_k :

$$(T_k)_1 = 78 \times \frac{79,2}{250} \times 10^1 = 247^\circ (\text{abs.}).$$

It is found that the critical temperature of Sb is at least $\hat{=} 2900^\circ$ (abs.), so that at this temperature Sb would be associated to about $\text{Sb}_{1,2}$.

For *carbon* with $(\sqrt{a_k})_1 = 3,1 \times 10^{-2}$, $(b_k)_1 = 100 \times 10^{-5}$ we should have found:

$$(T_k)_1 = 78 \times \frac{9,61}{100} \times 10^1 = 75^\circ (\text{abs.}),$$

whereas the critical temperature of C is certainly lying above 6000° abs., so that for T_k carbon would at least have to be $= C_{80}$.

And the same thing holds with respect to silicium and all the metals ¹⁾.

In the second place we draw attention to this, that substances like CCl_4 , SnCl_4 etc., where the attraction of the C- or the Sn-atom is cancelled, will consequently have a *relatively low* critical temperature. That is to say that these and similar substances (CH_4 , NH_3 , PH_3) would be *much less volatile* at the ordinary temperature, when the said circumstance were not present.

Thus $\sqrt{a_k} = 0 + 4 \times 5,4 = 21,6$ for CCl_4 , whereas, if the attraction of C could make itself felt, $\sqrt{a_k}$ would be $= 24,7 (\times 10^{-2})$. That is to say: now a is only 467, whereas it would be 610 in case of attraction of C. Hence in the latter case we should have found for T_k the value 556,2 (the real value of T_k), multiplied by $610 : 467$, so that we should have found $726^\circ,5$ absolute $= 453^\circ \text{C.}$ instead of 283°C. The difference (170°) is very large.

For SnCl_4 , with $\sqrt{a_k} = 9$ for Sn, the value of $\sqrt{a_k}$ would have been found 30,6 instead of 21,6, i. e. that of a_k 936 instead of 467, which would have brought T_k to 1189° abs. $= 916^\circ \text{C.}$ instead of 319°C. , as it is now. Hence a difference of 600° .

If for NH_3 the attraction of the central C-atom could have made itself felt, then $\sqrt{a_k}$ would have been $= 2,9 + 3 \times 3,2 = 12,5$ instead of 9,6, so that then T_k would have come from 406,0 to

¹⁾ In a following paper we shall however, mention — besides such a formidable association at T_k — another unexpected circumstance, which can account for the high critical temperature for metals and some metalloids.

$406 \times (156 : 92) = 688^\circ \text{ abs.} = 415^\circ \text{ C.}$, whereas now the critical temperature of ammonia only amounts to 133° C.

And as last example CH_4 . Here *with* the attraction of C $\sqrt{a_k}$ would be $= 3,1 + 4 \times 1,6 = 9,5$ instead of $6,4$, so that T'_k would then have become $= 190,2 \times (90 : 41) = 418^\circ \text{ abs.} = + 145^\circ \text{ C.}$, instead of $- 83^\circ \text{ C.}$, as it really is.

All these substances therefore owe their relative volatility, resp. low critical temperature, to the circumstance that the central atoms cannot make their attractive action felt towards the outside, in consequence of the absorbing action of the surrounding atoms. Substances with double or multiple bindings (C_2H_4 , C_2H_2), where the attractive action can operate again fully or partially (see I), will, therefore, at once be relatively less volatile than those of the category considered just now.

III. The critical values of mercury.

a) Calculation of b_k from the densities of the solid halogen compounds.

According to the property of the straight diameter $\frac{1}{2}(d_1 + d_2) = 1 + \gamma(1 - m)$, hence at low temperatures, where the (reduced) density of the vapour d_2 can be neglected:

$$d_1 = \frac{v_k}{v_1} = 2[(1 + \gamma) - \gamma m].$$

As now $v_k = r b_k = \frac{1 + \gamma}{\gamma} b_k$, we have:

$$b_k = v_1 \times \frac{2\gamma[(1 + \gamma) - \gamma m]}{1 + \gamma} = v_1 \times 2\gamma \left[1 - \frac{\gamma}{1 + \gamma} m \right] \quad (1)$$

This formula enables us to calculate the value of b_k from v_1 (the molecular volume of the *liquid*), when γ (coefficient of direction of the straight diameter) and m (the reduced temperature) are known. And as at *low* temperatures the volume of the solid phase will not differ much from that of the liquid phase, the above formula may be used by *approximation* also for the calculation of b_k from the molecular volume of the solid phase.

Thus for Argon, where $\gamma = 0,75$, $b_k = v_1 \times 1,5(1 - \frac{3}{4}m)$. For $84^\circ(\text{abs.})$, i. e. at the triple point, the density is $= 1,413$, hence $v_1 = 39,88 : 1,413 = 28,2$. The value of m is $84^\circ : 151^\circ = 0,55$, so that $b_k = 28 \times 1,15 = 32,4$; i. e. expressed in the normal volume v_0 , $32,4 : 22412 = 144 \times 10^{-5}$, which is perfectly identical with the value of b_k calculated directly from T'_k and p_k in Treatise I.

The factor, therefore, by which v_1 is to be multiplied to get b_k , is $= 1,15$.

For solid *Oxygen* the density at 21° is $= 1,4256$, hence $v_1 = 32 : 1,426 = 22,4$. The factor by which we must multiply, has the value $1,5$ with $m = 21^\circ : 126^\circ = 1/6$ and $\gamma = 0,8$, so that b_k becomes $33,6$; i. e. expressed in v_0 , $33,6 : 22412 = 150 \times 10^{-5}$. Determined directly in I from T_k and p_k 142×10^{-5} was found, so that the value of b_k calculated from the solid phase (34° below the triple point) turns out only 5 or 6% too high.

The factor by which v_1 must be multiplied to get b_k , is therefore very variable, and depends in a high degree on γ and m . For *metals* and *salts*, where T_k lies between 1000° and 3000° abs., γ is generally in the neighbourhood of 1, and then we become:

$$b_k \approx v_1 (2 - m), \dots \dots \dots (1a),$$

in which m varies from $1/3$ to $1/10$, when v_1 is determined at the ordinary temperature ($\pm 300^\circ$ abs.). The factor, therefore, varies from 1,7 to 1,9. (The sign of inequality refers to the fact that v_1 of the solid phase is generally smaller than the value of v_1 , which would hold at the same temperature with regard to the liquid phase).

Now at T_k for HgCl_2 , HgBr_2 and Hgl_2 , ROTINJANZ (Z. f. ph. Ch. **87**, p. 253) has found resp. the values 976° , 1011° and 1072° absolute. We may therefore put $m = 0,28$ or $0,26$, which makes the factor $2 - m = 1,72$ or $1,74$. From

$$b_k = \frac{1,7}{22412} \times \frac{M}{D_1}$$

follows therefore:

For HgCl_2 :

$$b_k = \frac{1,72}{22412} \times \frac{271,52}{5,424} = 0,00384,$$

hence $\text{Hg} = 384 - 230 = 154 \times 10^{-5}$.

For HgBr_2 :

$$b_k = \frac{1,73}{22412} \times \frac{360,44}{5,738} = 0,00484,$$

which gives $\text{Hg} = 484 - 330 = 154 \times 10^{-5}$.

For Hgl_2 (yellow):

$$b_k = \frac{1,74}{22412} \times \frac{454,44}{6,060} = 0,00582,$$

giving $\text{Hg} = 582 - 440 = 142 \times 10^{-5}$.

For Hg in compounds we can therefore assume about:

$$b_k = 150 \times 10^{-5}.$$

For mercury itself we find from the density of liquid mercury at 0°C :

$$b_k = \frac{1,78}{222412} \times \frac{200,6}{13,6} = 117 \times 10^{-5}$$

GULDBERG calculated the critical density = 3,77. From this would therefore follow:

$$v_k = \frac{200,6}{3,77 \times 22412} = 238 \times 10^{-5}.$$

If $b_k = \frac{1}{2} v_k$ is assumed (to $\gamma = 1$ corresponds $r = 2$), he finds 119×10^{-5} . The value calculated from mercury itself, viz. about 120×10^{-5} , is therefore apparently lower than the value calculated from the compounds, viz. 150×10^{-5} — a phenomenon that can be explained by the different molecular states at T_k and at lower temperature.

β) Calculation of $\sqrt{a_k}$ from the values of T_k and b_k of the halogen compounds.

From $T_k = 78,03$ $a_k \cdot b_k$ (See § 2) follows immediately:

$$a_k = \frac{T_k}{78,03} \times b_k, \dots \dots \dots (2)$$

from which we can calculate a_k , as soon as besides T_k the value of b_k (e.g. according to the method of α) is known. For the mercury halogen compounds we now have successively:

For HgCl_2 :

$$a_k = \frac{976}{78,03} \times 384 \times 10^{-5} = 480 \times 10^{-4}; \sqrt{a_k} = 21,9 \times 10^{-2},$$

hence $\sqrt{a_k}$ for Hg = $21,9 - 2 \times 5,4 = 11,1 \times 10^{-2}$.

For HgBr_2 :

$$a_k = \frac{1011}{78,03} \times 484 \times 10^{-5} = 627 \times 10^{-4}; \sqrt{a_k} = 25,0,$$

from which Hg = $25,0 - 2 \times 6,9 = 11,2 \times 10^{-2}$.

For HgI_2 :

$$a_k = \frac{1072}{78,03} \times 582 \times 10^{-5} = 800 \times 10^{-4}; \sqrt{a_k} = 28,3,$$

hence Hg = $28,3 - 2 \times 8,8 = 10,7 \times 10^{-2}$.

For $\sqrt{a_k}$ for mercury in compounds we are therefore justified in assuming as mean value:

$$\sqrt{a_k} = 11,0 \times 10^{-2}.$$

The found value agrees perfectly with the expected value in the 5th principal series. In the 4th principal series an average of 9 was namely found for Iodine and Xenon — so that in view of the value 7 in the 3rd series — 11 could now be expected.

We can now also calculate the critical temperature and pressure of Hg, and find (see § 2):

$$T_k = 2 \times 630^\circ = 1260^\circ \text{ (abs.)}; p_k = 192 \text{ atm.},$$

as mercury is quite bimolecular at T_k .

Also the missing critical pressures of the mercury halogenides, investigated by ROTINJANZ, can now be calculated.

The following value follows namely for $p_k = \frac{1}{28} \frac{a_k}{b_k^2}$.

For HgCl_2 :

$$p_k = \frac{1 (21.9)^2 \cdot 10^{-10}}{28 (384)^2 \cdot 10^{-10}} = \frac{1 (219)^2}{28 (384)^2} = \frac{(57,03)^2}{28} = 116 \text{ atm.}$$

For HgBr_2 :

$$p_k = \frac{1 \left(\frac{250}{484}\right)^2}{28} = \frac{(51,65)^2}{28} = 95 \text{ atm.}$$

And for HgI_2 :

$$p_k = \frac{1 \left(\frac{283}{5,82}\right)^2}{28} = \frac{(48,63)^2}{28} = 84 \text{ atm.}$$

As the triple point temperature for mercury = $-38,84 + 273,09 = 234^\circ,25$ abs., and the boiling point temperature = $356,7 + 273,1 = 629^\circ,8$ abs., the ratios of these temperatures to the critical temperatures are resp.:

$$\frac{T_k}{T_t} = 5,4; \quad \frac{T_k}{T_s} = 2,0.$$

The first value is still higher than the highest found value, viz. 5,2 for Helium. Generally a value is found in the neighbourhood of 2¹⁾, so that in the liquid state Hg has probably another molecular weight than at T_k .²⁾

As to the second value, this too is considerably higher than the mean value for a great many normal substances, viz. 1,60. This

¹⁾ It is certainly remarkable that the ratio $T_k : T_{tr}$ lies either in the neighbourhood of $1\frac{1}{3}$ (e.g. CO_2), or in that of 2 (for many substances), or in that of $2\frac{2}{3}$ (for several substances), or in that of $3\frac{1}{3}$ (for a smaller number of substances), or at last in that of 4 (e.g. for iso-pentane). These values differ every time $\frac{2}{3}$ of a unit. 4 would be followed by $4\frac{2}{3}$ and $5\frac{1}{3}$ (for helium and mercury). We shall come back to this.

[Fritz thought that this ratio would be either 1,2 or 1,8 or 2,7, but this is evidently not quite correct, as one can see oneself, when one determines the quotient $T_k \cdot T_{tr}$ for a great number of substances. See the Table further on].

²⁾ Though it is less explicable then, that at lower temperature and smaller volume (two factors tending in the same direction) there would be less association present than at higher temperature.

too points to increasing association in the vapour of Hg_1 to Hg_2 , when the temperature gets higher.

In agreement with the abnormally high value of $T_k : T_s$, viz. 2,0 instead of 1,6, the value of f_s in VAN DER WAALS' vapour pressure formula

$$\log^{10} \frac{p_k}{p_s} = f_s \left(\frac{T_k}{T_s} - 1 \right)$$

will be comparatively low. For with $p_s = 1$ (atm.), $T_k : T_s = \varphi$ we have:

$$f_s = \frac{\log^{10} p_k}{\varphi - 1},$$

which (as $\log p_k$ has little influence as a rule) leads to a too low value of f_s , when φ is too large. We really find for mercury with $\varphi = 2$ for f_s the value $f_s = \log^{10} p_s = \log^{10} 192 = 2,28$, the mean value for many normal substances being $= 2,90 (= 6,7$ with NEPER'S log.).

γ). The course of the vapour-tension factor f for mercury.

Though for some associated substances, as acetic acid, methyl alcohol, etc. the value of f_s (hence also that of f_k) is found *greater* than for normal substances (mean 3,35 or with Nep. log. 7,7), the opposite behaviour can also be expected. For as the vapour-pressure curve for substances, which are almost entirely bi-molecular at the critical temperature, but gradually become mono-molecular on decrease of temperature (as is the case with mercury vapour), will evidently lie *above* the normal value for Hg_2 (the critical pressures of Hg_1 and Hg_2 are namely equal, whereas T_k for Hg_1 will be double T_k for Hg_2), the vapour pressure will be comparatively large, hence *f too small* at a temperature (referring to T_k of Hg_2) below $(T_k)_2$. For associating substances as acetic acid, however, where the association decreases at higher temperature, the vapour-pressure curve on the other hand — if namely at T_k the association has disappeared for the greater part — will lie *below* that for $(\text{Ac})_1$. In consequence at a certain value of $T : (T_k)_1$ below $(T_k)_1$ the vapour pressure becomes relatively too small, hence *f too large*.

All this refers to the said extreme cases. In intermediate cases — when the substance at T_k is only partly associated, so that T must be referred to a temperature *between* T_{k_1} and T_{k_2} — the value of f , in reference to the normal value at that reduced temperature m , will entirely depend on the value of m , and it is impossible to say beforehand whether in a definite case the value of f will be smaller or greater than the normal value of f .

Besides, the value of f can be modified, when in the dissociation of the double molecules increase or diminution of volume takes place, or when the heat of dissociation differs from 0. This is e.g. very apparent in the formula, which I derived before for f_k in the most general case ¹⁾.

For the value of $\left(\frac{T}{p_{12}} \frac{dp_{12}}{dT}\right)_k = f_k$ we find namely at T_k :

$$f_k = (f_k)_0 \times \varphi \left(1 + \lambda \frac{q'_k}{RT_k}\right),$$

in which $(f_k)_0$ is the value of f_k , when the substance were simple, i.e. β (degree of dissociation of the double molecules) = 0 or 1. The factor φ is a rather complicated function of β (and of the possible change of volume Δb for dissociation of $\frac{1}{2}$ double molecule to one single molecule), while λ is also a function of β and Δb . The quantity q' represents the *internal* heat of dissociation (absorbed) for the said dissociation. When $\Delta b = 0$, the value of φ is always < 1 , both in the neighbourhood of $\beta = 0$ and in that of $\beta = 1$. The latter is apparently in contradiction with what we observed above with regard to substances which behave as acetic acid, where for lower temperatures f is found greater than normal. But then we should forget that in the neighbourhood of T_k the association also of the acetic acid vapour — after having passed through a minimum in the neighbourhood of T_k — again increases with increase of temperature, just as for substances as mercury, water etc.

If $(f_k)_0$ lies in the neighbourhood of 7, the factor φ ($\Delta b = 0$ being assumed) is e.g. = 0,84 for $\beta = 0,1$, and 0,96 for $\beta = 0,9$. We find a minimum, viz. $\varphi = 0,72$, for $\beta = 0,4$. As far as λ is concerned, this coefficient is = 0 for $\beta = 0$ and $\beta = 1$, and reaches a maximum value, e.g. 0,22, for $\beta = 0,5$. For $\beta = 0,1$ λ is = 0,086; also for $\beta = 0,9$ λ is = 0,086. This quantity is namely symmetrical with respect to β .

If, therefore, also $q' = 0$, then in consequence of the factor φ the value of f_k can be as much as 28% smaller than the normal value. The value 7 can therefore decrease to 5 (when viz. for T_k the value of $\beta = 0,4$). For substances where $\beta = 0,1$ at T_k , the value 7 would any way have already been reduced to $7 \times 0,84 = 5,9$. Etc. If therefore we find for T_k a value for f that is *greater* than the normal one — as for acetic acid, methyl alcohol, etc. — then it is certain that q' differs from 0. (the value of Δb has but little influence). This is in perfect concordance with what we remarked

¹⁾ See Archives TEYLER 1908, p. 40—42, and also TheseProc. of Nov. 7, 1914, p. 606.

in § 2. For acetic acid and such substances with a minimum association near T_k the heat of dissociation of the double molecules must be comparatively large, namely $> f T_k$. If $\beta = 0,1$ for T_k , then $\lambda = 0,086 (\Delta b = 0)$. Hence with $q'_k = 7 T_k$ we have $\lambda \times (q'_k : R T_k) = 0,086 \times 3,5 = 0,30$, so that $f_k = (f_k)_0 \times 0,84 \times 1,30 = (f_k)_0 \times 1,09$, hence already $\bar{y} > (f_k)_0$. The value 7 would then already increase to 7,63. For $\beta = 0,2$ we have $\rho = 0,76$, $\lambda = 0,15$, when $\Delta b = 0$; hence when $q'_k = 7 T_k$, the factor of $(f_k)_0$ becomes $= 0,76 \times 1,52 = 1,15$, so that the normal value 7 has then already increased to 8,1.

From what precedes we see sufficiently that at T_k the value of f can be both smaller and greater than the normal one. For mercury, q' being probably very small, f_k will be somewhat too small (if β namely differs from 0), and then at lower temperature f will be continually *smaller* than is normal (see above). As soon as the dissociation to simple molecules is completed, f will of course have become normal again at the corresponding low temperatures. (In this "normal" course of f also the usual minimum in the value of f at about $m = 0,75$ is included, which minimum is generally about 6% lower than f_k).

After this digression, which is also necessary for what follows, we will determine the values of f for mercury at some temperatures below and above the boiling point on the supposition that $T_k = 1260$, $p_k = 192$ atm. We find what follows.

t	p	$\log p_k$	$\log p$	f_{10}	f
0° C.	0,00024 mm.	8,784		2,430	5,59 ⁵
50°	0,014	7,018		2,419	5,57
100°	0,270	5,733		2,409	5,55
150°	2,684	4,735		2,394	5,51
200°	17,015	3,933		2,365	5,45
250°	74,59	3,291		2,337	5,38
300°	246,7	2,772		2,309	5,32
$T_s = 357°$	760,0	2,283		2,283	5,26
400°	1459,6	1,989		2,281	5,25
450°	2996,1	1,688		2,270	5,23
500°	5435,0	1,429		2,273	5,23

It follows from this that at 0° C. Hg-vapour is not yet completely Hg₁, nor completely Hg₂ at 500° C. Yet it seems that between the boiling point (357°) and 500° the greatest deviation occurs between the real vapour curve and that which would hold, when mercury were Hg₂ all-over the temperature range. From this moment the approach to the latter curve will become closer and closer, and f_{10} will gradually increase to a value in the neighbourhood of 3, resp. f to 7.

The vapour pressures used are RAMSAY and YOUNG'S. At 50° the mean value has been taken between that of R. and Y. (0,015) and that of HERTZ (0,013); at 0° C. a value between that of HERTZ (0,00019) and that of v. D. PLAATS (0,00047). For $\log p_k$ has been taken $\log^{10} (192 \times 760) = 5,1641$. Further f_{10} has been calculated from $f_{10} = (5,1641 - \log^{10} p) : (T_1/T - 1)$.

d) Calculation of p_k and T_k from vapour pressure observations.

Reversely, when T_k is known and p_k unknown, we can determine the value of p_k from the vapour pressure course by approximation. For $\log p_k - \log p_1 = f(T_k - T_1) : T_1$ and $\log p_k - \log p_2 = f(T_k - T_2) : T_2$ follows from the vapour pressure formula for two temperatures T_1 and T_2 , so that

$$\frac{\log p_k - \log p_1}{\log p_k - \log p_2} = \frac{T_2 T_k - T_1}{T_1 T_k - T_2},$$

from which p_k can be determined. If for one of these temperatures, e.g. for T_2 , we take the boiling point T_s , then in atm. $p_2 = 1$, $\log p_2 = 0$, and (if we simply write T for T_1) we get:

$$\frac{\log p_k - \log p}{\log p_k} = \frac{T_s T_k - T}{T T_k - T_s},$$

from which follows:

$$\log p_k = \log p \times \frac{T T_k - T_s}{T_k T - T_s} \dots \dots \dots (3)$$

In this it has of course been supposed that the value of f does not appreciably differ for the two temperatures. The greatest chance to realise this exists, when we remain in the neighbourhood of the minimum of f . This may be illustrated by a few examples. PELLATON has found for *chlorine* (Thèse, Neuchatel, 1915, p. 20) $p = 2766$ mm. at 0° C. At this temperature and at the boiling point — 34°,5 f is near the minimum (somewhat above 0° C.). For T_k was found 144°,0 C., so that we have in atm.:

$$\log p_k = \log 3,6395 \times \frac{273,1}{417,1} \times \frac{178,5}{34,5} = 0,5610 \times 0,6547 \times 5,174 = 1,900,$$

hence $p_k = 79,4$ atm. (PELLATON found 76,1).

With $T_k = 141^\circ,0$ C. according to DEWAR $\log p_k$ would have been $0,5610 \times 0,6595 \times 5,087 = 1,882$, hence $p_k = 76,3$. (DEWAR found 83,9).

As f at $-34^\circ,5$ is somewhat greater than at 0° C., p_k must be $< 79,4$ (resp. 76,3). The value 76,1 found by PELLATON can thus be exact, that of DEWAR is probably too high.

If we calculate the values of a_k and b_k for Cl, found by us in I with the values found by PELLATON for T_k and p_k , viz. 417,1 abs. and 76,1 atm., we find the somewhat higher values $b_k = 251 \times 10^{-5}$, $\sqrt{a_k} = 11,5 \times 10^{-2}$, instead of $b_k = 226 \times 10^{-5}$, $\sqrt{a_k} = 10,9 \times 10^{-2}$; giving for Cl the values resp. 125 and 5,75. (From the compounds we found 115 and 5,4).

For mercury at 500° C. $p = 5435,0$ mm. = 7,151 atm. Further $T_s = 357^\circ$ C. = 630 abs., $T_k = 1260$ abs. Hence:

$$\log p_k = 0,8544 \times \frac{773}{1260} \times \frac{630}{143} = 0,8544 \times 2,703 = 2,309,$$

giving $p_k = 204$, while we have found 192 by another way.

The value of f being somewhat greater also here at 357° than at 500° , p_k must in any case be < 204 , so that 192 may be correct.

When the case presents itself that both T_k and p_k are unknown, it is yet possible to calculate both values — at least with some approximation. From $\log p_k - \log p = f \left(\frac{T_k}{T} - 1 \right)$ we have then namely:

$$f + \log p_k = \log p + \frac{f T_k}{T}.$$

If we now put $f + \log p_k = y$, $f T_k = x$, then

$$y = \log p + \frac{x}{T}, \quad \dots \dots \dots (4)$$

so that we can calculate the quantities x and y from two corresponding pairs of values. Then we have, however, only $f + \log p_k$ and $f T_k$ (again on the supposition that the value of f does not appreciably differ for one pair from that of the other pair). To eliminate further the value of f , we may make use of the found property of the quantities \sqrt{a} , that they will namely be about constant in a whole horizontal principal series of the periodic system, e.g. = 9 in the series of I and Sb, = 7 in the series of Br and As, etc.

In the special example of Hg $\sqrt{a_k} = 2 \times 11,0 \times 10^{-2}$ (as mercury is bi-molecular for T_k), so that we have from

$$\frac{(RT_k)^2}{p_k} = \frac{64}{27} \lambda \cdot a_k,$$

with $R = 1 : 273,1$ and $\lambda = 27/28$:

$$\frac{T_k^2}{p_k} = \frac{16}{7} (273,1 \times 2 \times 11,0 \times 10^{-2})^2 = \frac{16}{7} \times (60,08)^2 = 8252.$$

Now $T_k = x : f$, $\log p_k = y - f$, hence

$$\frac{x^2 : f^2}{10^{y-f}} = 8252, \text{ or } x^2 = 8252 f^2 \cdot 10^{y-f},$$

or also

$$2 \log x = \log 8252 + 2 \log f + y - f,$$

yielding

$$f - 2 \log f = y - 2 \log x + 3,9166, \dots \dots \dots (5)$$

from which f (in the case of *mercury*) can be calculated.

If for the calculation we choose the four temperatures beginning with the boiling point, because f changes only little there, we find — seeing that

$$x = \frac{\log p_1 - \log p_2}{1/T_2 - 1/T_1}$$

follows from (4) by subtraction — successively between

356,7° and 400°	$x = \frac{\log 1495,6 - \log 760}{(1:629,8) - (1:673,1)} = 2878$	$y = 7,451 - 2,881 = 4,570$
400° „ 450°	$x = \frac{\log 2996,1 - \log 1495,6}{(1:673,1) - (1:723,1)} = 2937$	$y = 7,539 - 2,881 = 4,658$
450° „ 500°	$x = \frac{\log 5435,0 - \log 2996,1}{(1:723,1) - (1:773,1)} = 2892$	$y = 7,476 - 2,881 = 4,595$

The value of y must, namely, everywhere be diminished by $\log 760 = 2,881$, because in $\log p$ the pressure p must not be expressed in m.m. but in atm., because also a_k is expressed in atm.

According to (5) the following equations follow from the found values of x and y :

$f - 2 \log f = 4,570 - 6,918 + 3,917 = 1,569$	$f = 2,288$
$= 4,658 - 6,936 + 3,917 = 1,639$	$f = 2,399$
$= 4,595 - 6,922 + 3,917 = 1,590$	$f = 2,322$

From $x = f T_k$ and $y = f + \log p_k$ we find then at once:

$T_k = 1258$;	1224	;	1245	}
$p_k = 191,4$;	181,6	;	187,7	

giving on an average $T_k = 1242^\circ$ abs.; $p_k = 187$ atm.

Though *both* values, as well T_k as p_k , are supposed to be unknown, yet we find for these quantities (and that for an abnormal substance, for which the state of association continually varies with the temperature) values, which differ only little from the values calculated in the other way. Those that were calculated between 357° and 400° , come very near, indeed, to the latter (viz. 1260° and 192 atm.).

We see from what precedes, that for many substances with as yet unknown p_k or even unknown p_k and T_k these quantities can be calculated with some approximation from a few vapour pressure observations; in the last mentioned case (p_k and T_k unknown) by the aid of the probable value of $\sqrt{a_k}$. But the molecular state in the critical point must then be accurately known.

ε) *Calculation of T_k from the temperature of the boiling point.*

If the foundation of the calculation of the foregoing paragraph is wanting, in consequence of the molecular state at T_k , hence also $\sqrt{a_k}$, being unknown, the equation (4) is still valid. We can, therefore, always determine x and y from two vapour pressure observations, i.e. fT_k and $f + \log p_k$. If the observations are made in the neighbourhood of the boiling point, we can still determine the values of T_k and p_k with some approximation from the approximated value of f at this point (determined from the mean value for a number of analogous substances).

Besides T_k can be determined directly from T_s , when the mean value of the ratio $T_k : T_s$ is used as first approximation.

We will, therefore, in the first place consider the values of f_k and $T_k : T_s$ more closely.

In the following table, besides T_k and p_k , the triplepoint temperature T_t and the boilingpoint temperature T_s of a great number of substances have been given, and also the ratios $T_k : T_t$ and $T_k : T_s$. Further $\log p_k$ and f_s . The ratio $T_k : T_s$ will depend on $\log p_k$ according to the relation ($p_s = 1$ atm.)

$$\log \frac{p_k}{1} = f_s \left(\frac{T_k}{T_s} - 1 \right),$$

so that:

$$\frac{T_k}{T_s} = \frac{\log p_k}{f_s} + 1 \dots \dots \dots (6)$$

Now — at least for ordinary substances, where the critical temperatures are not excessively low — the values of f_s (for *normal* substances) will not diverge very much, so that $T_k : T_s$ would have about the same value for all such substances, if $\log p_k$ had the same

value for all. This is, however, not the case; yet the critical pressures do not diverge so much that $\log p_k$ moves within a wide margin: in most cases the values of p_k lie between 40 and 60 atm., hence $\log p_k$ between 1,60 and 1,78. This would cause $T_k : T_s$ (with f_s on an average 2,9) to lie between 1,55 and 1,61. Only in extreme cases will p_k ascend to 100 atm. or descend to 20 atm. Then $\log p_k$ would become resp. = 2 and 1,30, hence $T_k : T_s$ resp. = 1,69 and 1,45, so that then too the values of this last ratio comparatively do not lie far apart. Practically the said ratio can only vary between 1,45 and 1,69 — though $\log p_k$ can lie between 1,3 and 2; in most cases it will vary even between the still narrower limits 1,55 and 1,61. As mean value **1,60** can be given, so that — and strictly speaking this holds only for normal substances, or such associated substances as no longer change in the neighbourhood of T_s , as far as their molecular state is concerned — one can conclude in many cases to the *critical temperature* from the temperature of the *boiling point*. (See following table.)

The mean value of the ratio $T_k : T_s$ for the 49 *anorganic* substances, for which we could calculate this ratio, amounts to $1 + (327 : 49) = 1,638 = \mathbf{1,64}$.

That for the *organic* substances is somewhat lower; we found for the 58 substances, for which $T_k : T_s$ was calculated: $1 + (3244 : 58) = 1,559 = \mathbf{1,56}$.

The mean of all the 107 substances amounts to $1 + 6371 : 107) = 1,595 = \mathbf{1,60}$.

The ratio $T_k : T_r$ does not exhibit any perceptible regularity; the cause of the great difference, which often exists for closely allied substances with respect to this ratio, has not yet been explained. We need only think of 1,40 for CO_2 , 3,38 for CS_2 .

With regard to the application of the rule $T_k : T_s = 1,60$ for substances as As, Sb, Al, Hg, etc., we should bear in mind that these and suchlike substances can be greatly associated, and that the state of association between the boiling point and the critical point can still vary pretty considerably. Accordingly we shall often find values deviating more or less considerably from the mean value. Thus the ratio $T_k : T_s$ is even 2,00 for mercury.

IV. The critical values of Antimonium.

In the formula (1a) the value of m at the ordinary temperature, referring to the critical temperatures of the compounds SbCl_3 , SbBr_3 , SbI_3 , will be about $\frac{1}{3}$ or $\frac{1}{4}$, so that $b_k \geq 1,67 v_1$ or $1,75 v_1$.

2

Proceedings Royal Acad. Amsterdam, Vol. XIX.

Anorganic Substances.

	T_{tr}	p_{tr}	T_s	T_k	p_k	$\log^{10} p_k$	f_s^{10}	f_s	$\frac{T_k}{T_s}$	$\frac{T_k}{T_{tr}}$
He	± 1		4,20	5,20	$>2,26$	0,354	1,49	3,43	1,24	5,20
Ne	24,42	32,35 cm.	27,17	45?	29	1,462	2,23	5,13	1,66	1,84
Ar	83,79	51,6 "	87,25	150,65	48,0	1,681	2,31	5,32	1,73	1,80
Kr	104,1		121,4	210,5	54,3	1,735	2,36	5,44	1,73	2,02
X	133,1		164,1	289,7	58,2?	1,765	2,31	5,31	1,77	2,18
H ₂	13,9	5,4 "	20,32	31,95	15,0	1,176	2,06	4,73	1,57	2,30
N ₂	63,06	9,0 "	78,0	126,0	33,5	1,525	2,48	5,71	1,61	2,00
O ₂	54,7	0,11 "	90,10	154,3	49,7	1,696	2,38	5,48	1,71	2,82
*P ₄ (viol.)	862,6	43,1 atm.	687(su.)	968	82,8	1,918	2,56	5,90	1,75	1,12
S ₂	392,0		717,6	970?	—	—	—	—	—	—
F ₂	50		86	103?	—	—	—	—	—	—
Cl ₂	171,6		238,6	417,1	76,1	1,881	2,51	5,79	1,75	2,44
Br ₂	265,8		331,8	575,3	—	—	—	—	1,73	2,16
I ₂	386,8	9,1 cm.	456,1	785,1	—	—	—	—	1,72	2,03
*(HF) ₂	180,8		292,6	500?	—	—	—	—	—	—
HCl	161,8		190,2	324,5	81,55	1,911	2,71	6,23	1,71	2,01
HBr	187,1		204,4	364,4	—	—	—	—	1,78	1,95
HI	222,3		237,4	423,8	—	—	—	—	1,79	1,91
*H ₂ O	273,1	0,457 cm.	373,1	638,1	200,5	2,302	3,24	7,47	1,71	2,34
H ₂ S	187,1		211,5	373,5	89,05	1,950	2,55	5,86	1,77	2,00
H ₂ Se	209,1		231,6	410,1	91,0	1,959	2,54	5,85	1,77	1,96
NH ₃	195,4		239,6	406,0	112,3	2,050	2,95	6,80	1,69	2,08
(NH ₂) ₂	274,5		386,6	—	—	—	—	—	—	—
N ₂ O	170,8		183,3	309,6	71,65	1,855	2,69	6,20	1,69	1,81
NO	112,5	14 cm.	122,9	180,2	64,6	1,810	3,88	8,94	1,47	1,60
*NO ₂	263,0		294,7	431,3	100	2,000	4,32	9,94	1,46	1,64
PH ₃	140,6		186,7	325,9	64,0	1,806	2,42	5,58	1,75	2,32
PCl ₃	161,3		349,0	558,6	—	—	—	—	1,60	3,46
POCl ₃	274,3		380,3	604,9	—	—	—	—	1,59	2,21
AsH ₃	159,6		218,3	—	—	—	—	—	—	—
AsCl ₃	255		403,3	629?	—	—	—	—	1,56	2,47

Anorganic Substances (continued).

	T_{tr}	p_{tr}	T_s	T_k	p_k	$\log^{10} p_k$	f_s^{10}	f_s	$\frac{T_k}{T_s}$	$\frac{T_k}{T_{tr}}$
SbH ₃	181,6		255	—	—	—	—	—	—	—
SbCl ₃	346,3		496	797	61?	1,785	2,94	6,77	1,61	2,30
SbBr ₃	363		553	904,5	56?	1,748	2,75	6,33	1,64	2,49
SbI ₃	440		674	1101	55?	1,740	2,74	6,32	1,63	2,50
SO ₂	201,4		263,0	430,2	77,65	1,890	2,97	6,84	1,64	2,14
S ₂ Cl ₂	—		411,2	664,4?	—	—	—	—	1,62	—
SOCl ₂	—		351,9	569,9	—	—	—	—	1,62	—
SO ₂ Cl ₂	—		343,0	549,7	—	—	—	—	1,60	—
TeCl ₂	448		597	—	—	—	—	—	—	—
TeCl ₄	487		687	—	—	—	—	—	—	—
Hg ₂	234,25		629,8	1260?	192?	2,283	2,28	5,25	2,00	5,38
HgCl ₂	560		577,4	976	116?	2,064	2,99	6,88	1,69	1,74
HgBr ₂	517		593,3	1011	95?	1,978	2,81	6,47	1,70	1,96
HgI ₂	514		626,5	1072	84?	1,924	2,71	6,23	1,71	2,09
BCl ₃	—		291,3	—	—	—	—	—	—	—
BBr ₃	—		363,6	—	—	—	—	—	—	—
BI ₃	316		483	—	—	—	—	—	—	—
AlCl ₃	463?	2,5 atm	456 (su.)	629,5	—	—	—	—	1,38	1,36
AlBr ₃	366		533	772	—	—	—	—	1,45	2,11
AlI ₃	398		623	955	—	—	—	—	1,53	2,40
(CN) ₂	238,7		252,5	401,4	59,75	1,776	3,01	6,92	1,59	1,68
HCN	259,7		299,6	—	—	—	—	—	—	—
CO	66,1	10 cm.	83,1	133,4	35,5	1,550	2,56	5,90	1,61	2,02
CO ₂	216,9	5,1 atm.	194 (su.)	304,1	72,93	1,863	3,29	7,57	1,57	1,40
CS ₂	161,5		319,3	546,1	72,9	1,863	2,62	6,04	1,71	3,38
COS	—		—	378,1	—	—	—	—	—	—
SiCl ₄	—		330,7	503,1	37?	1,568	3,01	6,93	1,52	—
SiBr ₄	260		426	656?	—	—	—	—	1,54	2,52
SiI ₄	393,6		563?	—	—	—	—	—	—	—
TiCl ₄	—		409,5	631?	—	—	—	—	1,54	—
GeCl ₄	—		359,1	550,0	38,0	1,580	2,98	6,85	1,53	—
SnCl ₄	240,1		387,2	591,8	36,95	1,568	2,96	6,83	1,53	2,47

Organic Substances.

	T_{tr}	p_{tr}	T_s	T_k	p_k	$\log^{10} p_k$	f_s^{10}	f_s	$\frac{T_k}{T_s}$	$\frac{T_k}{T_{tr}}$
CH ₄	89,94	7 cm.	108,4	190,2	53 ?	1,724	2,28	5,25	1,75	2,12
C ₂ H ₆	95,6		189,0	305,2	48,9	1,689	2,75	6,32	1,61	3,19
C ₃ H ₈	—		228,1	370,6	45,0	1,653	2,64	6,09	1,62	—
n-C ₄ H ₁₀	—		274,1	424 ?	37 ?	1,568	2,87	6,60	1,55	—
(n-C ₅ H ₁₂)	142,3		309,2	470,3	33,03	1,519	2,92	6,71	1,52	3,30
i-C ₅ H ₁₂	115,0		301,0	460,9	32,92	1,517	2,86	6,58	1,53	4,01
n-C ₆ H ₁₄	—		342,0	507,9	29,6	1,471	3,03	6,98	1,49	—
n-C ₇ H ₁₆	—		371,5	539,9	26,9	1,430	3,16	7,27	1,45	—
n-C ₈ H ₁₈	—		398,9	569,3	24,6	1,391	3,26	7,50	1,43	—
C ₂ H ₂	192,1	1,25 atm.	190,7(su.)	308,6	61,65	1,790	2,90	6,67	1,62	1,61
C ₂ H ₄	104,1		170,6	282,2	50,65	1,705	2,61	6,00	1,65	2,71
i-C ₅ H ₁₀	—		—	464,7	33,9	1,530	—	—	—	—
C ₆ H ₆	278,5		353,3	561,6	47,89	1,680	2,85	6,56	1,59	2,02
C ₇ H ₈	178,6		383,8	593,7	41,6	1,619	2,96	6,82	1,55	3,32
o-C ₈ H ₁₀	245,1		417,1	636,1	36,9	1,567	2,98	6,87	1,53	2,60
Cyclohexane	—		353,9	553,1	39,8	1,600	2,84	6,54	1,56	—
C ₁₀ H ₈	353,2		491,05	741,3	39,2	1,593	3,13	7,21	1,51	2,10
CH ₃ F	—		—	318,0	62,0	1,792	—	—	—	—
CH ₃ Cl	181,6		249,4	416,3	65,9	1,819	2,71	6,25	1,67	2,29
CH ₂ Cl ₂	—		314,7	518,3	—	—	—	—	1,65	—
CHCl ₃	209,8		334,3	536,0	53,8	1,731	2,87	6,61	1,60	2,55
CCl ₄	250,1		349,8	556,2	44,97	1,653	2,80	6,45	1,59	2,22
C ₂ H ₅ Cl	134,4		286,2	455,6	54	1,732	2,93	6,74	1,59	3,39
C ₂ H ₅ Br	154,1		311,5	509,1	—	—	—	—	1,63	3,30
C ₂ H ₅ I	161,1		345,6	559,1	—	—	—	—	1,62	3,47
C ₂ H ₄ Cl ₂	308,4		356,8	562,4	53	1,724	2,99	6,89	1,58	1,82
C ₂ H ₄ Br ₂	282,7		404,2	583,1	—	—	—	—	1,44	2,06
C ₃ H ₇ Cl	150,3		319,7	494,1	49,0	1,690	3,10	7,14	1,55	3,29
(CH ₃) ₂ O	—		249,4	400,2	53	1,724	2,85	6,56	1,60	—
(C ₂ H ₅) ₂ O	156,9		307,7	466,9	35,60	1,551	3,00	6,90	1,52	2,98
(CH ₃ , C ₂ H ₅)O	—		284,1	441,5	46,3	1,666	3,01	6,92	1,55	—

Organic Substances (continued).

	T_{tr}	p_{tr}	T_s	T_k	p_k	$\log^{10} p_k$	f_s^{10}	f_s	$\frac{T_k}{T_s}$	$\frac{T_k}{T_{tr}}$
*CO(CH ₃) ₂	178,8		329,4	505,9	52,2	1,718	3,21	7,39	1,54	2,83
H.COOCCH ₃	—		305,0	487,1	59,25	1,773	2,97	6,84	1,60	—
CH ₃ .COOCCH ₃	—		330,2	506,8	46,3	1,666	3,11	7,17	1,53	—
CH ₃ COOC ₂ H ₅	189,7		350,2	523,2	38,0	1,580	3,20	7,36	1,49	2,76
CH ₃ COOC ₃ H ₇	—		374,6	549,3	33,2	1,521	3,26	7,52	1,47	—
C ₆ H ₅ F	232,1		358,3	559,6	44,62	1,650	2,94	6,76	1,56	2,41
C ₆ H ₅ Cl	228,1		405,1	632,3	44,64	1,650	2,94	6,77	1,56	2,77
C ₆ H ₅ Br	242,5		429,2	670,1	44,6	1,649	2,94	6,77	1,56	2,76
C ₆ H ₅ I	241,7		461,6	721,1	44,6	1,649	2,93	6,76	1,56	2,98
C ₄ H ₄ S	—		—	590,4	47,7	1,679	—	—	—	—
*CH ₃ OH	176,0		337,8	513,1	78,5	1,895	3,65	8,41	1,52	2,92
*C ₂ H ₅ OH	143,1		351,4	516,2	62,96	1,799	3,84	8,84	1,47	3,61
*C ₂ H ₅ SH	128,6		309,1	501,1	—	—	—	—	1,62	3,90
*n-C ₃ H ₇ OH	—		370,3	536,8	50,2	1,701	3,78	8,70	1,45	—
*C ₆ H ₅ OH	314,2		454,5	692,3	—	—	—	—	1,52	2,20
*HCOH	—		252,1	496,7	—	—	—	—	1,97	—
*CH ₃ .COH	149,6		293,3	461,1	—	—	—	—	1,57	3,08
*(CH ₃ .COH) ₃	283,6		396,1	559,1	—	—	—	—	1,41	1,97
*H.COOH	281,6		373,7	640?	—	—	—	—	1,71	2,27
*CH ₃ .COOH	289,8		391,6	594,7	57,11	1,757	3,38	7,78	1,52	2,05
*C ₂ H ₅ COOH	253,8		413,4	599,9	—	—	—	—	1,45	2,36
CH ₃ CN	228,2		354,7	547,8	—	—	—	—	1,54	2,40
C ₂ H ₅ CN	—		—	564,3	—	—	—	—	—	—
NH ₂ CH ₃	—		267	428	72	1,857	3,08	7,09	1,60	—
NH ₂ C ₂ H ₅	192,5		289,7	450	66	1,820	3,29	7,58	1,55	2,34
NH ₂ C ₃ H ₇	—		322	491	50	1,699	3,24	7,45	1,52	—
NH(CH ₃) ₂	—		281,6	436	56	1,748	3,18	7,33	1,55	—
NH(C ₂ H ₅) ₂	229,1		330	489	40	1,602	3,32	7,65	1,48	2,13
NH(C ₃ H ₇) ₂	—		—	550	31	1,491	—	—	—	—
N(CH ₃) ₃	—		276	433,5	41	1,613	2,83	6,52	1,57	—
N(C ₂ H ₅) ₃	158,3		362,5	532	30	1,477	3,16	7,27	1,47	3,36
NH ₂ C ₆ H ₅	266,9		457,5	698,7	52,35	1,719	3,26	7,51	1,53	2,62

ROTINJANZ found namely recently (Z. f. ph. Ch. **87**, p. 635) for T_k resp. 797° , $904,05^\circ$ and 1101° absolute.

The sign of inequality in the above relation refers to the solid state, and as $b_k = 250 \times 10^{-5}$ has already been found by another way (See Treatise I), the factors 1,67 or 1,75 will have to be raised to 1,8 or 1,9. [In what follows we shall have to take this into account, and (for *solid* compounds) we can replace the sign of inequality by the sign of equality by increasing the factor $2-m$ by about 10%].

For the antimonium compounds we then get (see § 3):
SbCl₃:

$$b_k = \frac{1,8}{22412} \times \frac{226,58}{3,06} = 0,00595,$$

hence Sb = 595 - 345 = 250 $\times 10^{-5}$.

SbBr₃:

$$b_k = \frac{1,9}{22412} \times \frac{359,96}{4,15} = 0,00736,$$

giving Sb = 736 - 495 = 241 $\times 10^{-5}$.

SbI₃:

$$b_k = \frac{1,9}{22412} \times \frac{500,96}{4,68} = 0,00908,$$

hence Sb = 908 - 660 = 248 $\times 10^{-5}$.

For the density of SbI₃ that of the monoclinic form has been taken. That of the hexagonal form ($D_1 = 4,85$) would have given too low a value. Now the results are in very good concordance with the value 250×10^{-5} calculated before — a proof that (1) or (1a) is very suitable for the calculation of b_k . In this we can also bring the value of γ to 1,09 instead of augmenting the factor $2-m$ ($\gamma = 1$) by 10% (see above). For substances with critical temperatures of 800 or 1000° abs. the (reduced) coefficient of direction of the straight diameter can, namely, exceed unity. Instead of (1a) we had better take then according to (1):

$$\underline{b_k = v_1 (2,18 - 1,14 m)} (1b)$$

As factor of v_1 with $m = 1/3$ this yields then the value $2,18 - 0,38 = 1,8$, and with $m = 1/4$ the value $2,18 - 0,285 = 1,9$, which factors agree with what was found above.

From formula (2), i. e. $a_k = (T_k : 78,03) \times b_k$, the following values now follow immediately for the three said compounds.

$$\begin{array}{l}
 a_k = \frac{797}{78,03} \times 595 \cdot 10^{-5} = 608 \cdot 10^{-4} \\
 a_k = \frac{904,5}{78,03} \times 736 \cdot 10^{-5} = 863,5 \cdot 10^{-4} \\
 a_k = \frac{1101}{78,03} \times 908 \cdot 10^{-5} = 1286 \cdot 10^{-4}
 \end{array}
 \left|
 \begin{array}{l}
 \sqrt{a_k} = 24,7 \cdot 10^{-2} \\
 29,4 \cdot 10^{-2} \\
 35,9 \cdot 10^{-2},
 \end{array}
 \right.$$

so that we find for Sb itself:

$$\begin{array}{l}
 \sqrt{\sigma_k} = 24,7 - 16,2 = 8,5 \cdot 10^{-2} \\
 29,4 - 20,7 = 8,7 \cdot 10^{-2} \\
 35,9 - 26,4 = 9,5 \cdot 10^{-2},
 \end{array}$$

hence for Sb on an average:

$$\sqrt{a_k} = 8,9 \times 10^{-2},$$

in concordance with the expected value in the 4th horizontal row of the periodic system, which is about 9×10^{-2} ($I = 8,8$, $X = 9,1$; cf. the table in § 1).

We should now find for the critical temperature of Sb—supposing that Sb at T_k possessed the formula Sb_1 :

$$T_k = 78,03 \frac{a_k}{b_k} = 78,03 \times \frac{79,2 \cdot 10^{-4}}{250 \cdot 10^{-5}} = 247^\circ \text{ absolute.}$$

The boiling point of Antimonium being 1440°C or 1713° abs , T_k will not be lower than $1713 \times 1,7 \text{ à } 2$, i. e. $\pm 2900^\circ$, so that at the critical temperature the molecular formula of Antimonium will have to be at least $Sb_{1,2}$ 1).

The following values now follow from $p_k = \frac{1}{28} \frac{a_k}{b_k^2}$ (see § 2 and § 3, β) for the critical pressures of $SbCl_3$, $SbBr_3$, and SbI_3 , and also of Sb itself.

$$\begin{array}{l}
 SbCl_3 : p_k = \frac{1}{28} \frac{608 \cdot 10^{-4}}{(595 \cdot 10^{-5})^2} = 61 \text{ atm.} \\
 SbBr_3 : p_k = \frac{1}{28} \frac{863,5 \cdot 10^{-4}}{(745 \cdot 10^{-5})^2} = 56 \text{ ,,} \\
 SbI_3 : p_k = \frac{1}{28} \frac{1286 \cdot 10^{-4}}{(910 \cdot 10^{-5})^2} = 55 \text{ ,,} \\
 Sb : p_k = \frac{1}{28} \frac{79,2 \cdot 10^{-4}}{(250 \cdot 10^{-5})^2} = 45 \text{ ,,}
 \end{array}$$

With these values of p_k and those for $HgCl_2$ etc. the values of f_s for these compounds have been calculated in the large table of § 3; they are in perfect agreement with the values for ordinary

1) See, however, note 2 of § 2.

normal substances, so that neither the mercury halides, nor those of Sb exhibit any association. The molecular formulae for these latter compounds will, therefore, no doubt be $SbCl_3$, etc., and not Sb_2Cl_6 , etc.

After these somewhat lengthy expositions I can be a good deal shorter in future, now that the Methods for the further calculation have been sufficiently set forth and elucidated by the examples of mercury and also of antimonium.

In the determination of the values of b_k and $\sqrt{a_k}$ for the different metals and the remaining elements of the periodic system we shall, therefore, have to refer continually to this second Paper.

Aluminium, Borium, Arsenicum, Bismuth, Tellurium, Silicium etc. will be treated first.

Clarens, March 1916.

Zoology. — “*On the Setal Pattern of Caterpillars.*” By A. SCHIERBEEK. (Communicated by Prof. J. F. VAN BEMMELEN.)

(Communicated in the meeting of March 25, 1916).

In 1876 WEISMANN proved the ontogeny of the peculiar colour-patterns occurring in many Sphingide-caterpillars to be a further differentiation of the linear ornamentation. From this he concluded that the ocellar and annular markings had also phylogenetically taken origin from longitudinal stripes, and he could back this inference by the fact, that the intermediate stages, which in some genera and species were passed through during their growth, acted as terminal stages in other forms. From that time onwards many investigators have occupied themselves with the study of the external appearance of caterpillars. Independently of each other WILH. MULLER and DYAR called attention to the regular arrangement of the setae in different families; O. HOFMANN, PACKARD, QUAIL, TSOU¹⁾ and others followed them in their track.

J. F. VAN BEMMELEN (1913) pointed out the connections between the colour-pattern of caterpillars, pupae and imagines, which indeed had been remarked by other students, e.g. POULTON, but had not been considered of real importance. VAN BEMMELEN's views therefore introduced a new aspect into the discussions, as he defended the homology of pigmentspots with tubercula and setae. This connection

¹⁾ Tsou's paper only came into my hands, after the writing of the present communication.

had been overlooked by FRACKER, who in 1915 made a careful study of the setal pattern of a great many caterpillars.

The majority of investigators have introduced their own nomenclature for the arrangement of the setae, refusing to accept that of their predecessors, as it repeatedly became evident that each enlargement of our knowledge claimed new indications for the details of the pattern. Hoping to evade the difficulties, several authors, following the example of DYAR, took refuge in ciphers. But this only aggravated the confusion, as DYAR himself was obliged after a few years to propose a new numbering, which others again tried to emendate. So FRACKER preferred the notations of the greek alphabet, thinking that as their succession was less familiar to our modern minds, it would not lead so easily to false conclusions about homologies.

He designs "one single generalized segment (fig. 1) by plotting, one segment over the other, the setae of the prothorax, metathorax, and abdomen of the generalized members of the different genera, families and suborders of Lepidoptera, as if they all were on the same segment." (p. 17). To this generalized type he ascribes a great value, as he believes he has reconstructed by this method the ancestral pattern. In those cases where the number of setae is less than it should be according to this hypothesis, he explains their absence by retrogression (he supposes the absent ones to have remained undeveloped). The nearest approach to this generalized type he sees in the arrangement of the setae on the prothorax of *Hepialus, instar I*. Yet it must at once be stated that FRACKER did not observe this species himself, but only judged by a drawing (without accompanying description) of DYAR after *Hepialus mustelinus*. The notation of the setae after FRACKER's system may be seen in Fig. 1.

In August 1914 Prof. J. F. VAN BEMMELEN called my attention to the question of the arrangement of the setae, and from that date onward I have been occupied in investigating the transformation of the setal pattern during the larval period of Lepidoptera. The paper in full, containing detailed descriptions of the successive instars and exact non-schematic figures, will before long be published in: *Onderzoekingen verricht in het Zoologisch Laboratorium der Rijks-Universiteit te Groningen*. The bibliography will also be given. Here may follow only the chief results of my investigations; they were obtained before FRACKER's paper came into my hands, and they are often in contradiction with his observations. Moreover they specially deal with the youngest instars of the larvae, which FRACKER disregarded in most cases.

In my opinion the setae must be homologized according to their arrangement in regard not only to each other, but also to other organs occurring on the external surface of the larval body, of which the stigma undoubtedly is the most important. Yet the place of this opening is not always the same. For on the prothorax it is situated near to its caudal border, the segments of the abdomen on the contrary bear their stigmata in their oral half. A dislocation of the stigma therefore probably has taken place. Without deciding which position of the stigma should be considered the most primitive¹⁾, one thing may be safely accepted as an incontestable fact, i. e. that such a dislocation will exercise a certain influence on the setae in its neighbourhood.

FRACKER however, judging by his fig. 1 (♂ and ♂), seems to suppose that the stigma might be able to dive, as it were, beneath a seta and so pass it without in the least disturbing its position. I am sorry to say that I cannot possibly agree with such an opinion, as I am convinced that a seta on the oral side of the stigma will always maintain its anterior position. For this reason I prefer for the setae a system of names instead of ciphers or letters, because in that way the situation of the setae is indicated at the same time. Moreover by adopting names, I can remain in harmony with the nomenclature of WEISMANN, W. MULLER and J. F. VAN BEMMELEN, and so act according to the rules of priority, which should be observed also in cases like these. For the sake of clearness the use of names is by far to be preferred to that of ciphers or letters.

My observations led me to the conclusion that a far going correspondence exists between the arrangements of the *setae* (hairs), *tubercles* (eminences usually bearing one or more setae), *verrucae* (warts with many setae), *scoli* (prominent spines), and *pigmental spots*. I therefore consider all these dermal products to be homologous. A homogeneous dispersion of setae or their total absence are both secondary modifications.

Different types of pattern may be distinguished, but they can be deduced from each other.

Type I. The most widely spread, as it occurs on the abdominal segments of almost all caterpillars, when newly hatched (Instar I), and in many species is retained during the whole larval period. Moreover, the pattern on the prothorax of these caterpillars corresponds in its main features with the abdominal one. In the following list the setae marked with an asterisk usually occur on the prothorax

¹⁾ In a following paper I hope to give some information in this question.

only. Whenever they are also present on the abdomen, this will be mentioned in the description. But where *type I* is given for a certain family, this has no relation to the *setae. The type therefore consists of:

Seta (etc.) *dorsalis*, oral and at the same time dorsal.

S. subdorsalis superior, more caudal and in some cases also somewhat ventral to the foregoing.

**S. subdorsalis inferior*, ventral to the preceding.

**S. dorsolateralis*, on the oral border of the segment between *s. dorsalis* and *s. suprastigmalis*.

S. suprastigmalis, above the stigma in a vertical line with *s. dorsalis* and *s. dorsolateralis*.

**S. prostigmalis*, anterior to the stigma.

S. poststigmalis, caudal and usually a little ventral to the stigma.

S. infrastigmalis, beneath the stigma.

S. basalis anterior, and

S. basalis posterior, between *s. infrastigmalis* and the insertion of the leg, or where this is absent, between *s. infrastigmalis* and *s. pedalis*.

S. pedalis, on the base of the leg, or when the leg is obsolete, on the corresponding spot. I consider this seta as a proof of the secondary reduction of prolegs on the abdominal segments 1,2,7,8,9. The legs of the thorax and sometimes those of the abdomen are generally well provided with hairs. To these I did not give names, as they nearly always differ in shape and size from the above named primary ones, and so may be fairly considered of secondary nature.

**S. propedalis*, on the ventral side, before the anterior margin of the leg.

S. ventralis, between the inner side of the leg and the ventral, median-line.

The reductions, occurring within the limits of this type, generally are traceable in the ontogeny of one and the same species, or by comparison between the different species of one and the same family. The hinder abdominal segments usually differ a little from the type. The simplifications, corresponding with this deviation may be considered as secondary modifications, though they often lead to pseudo-primitive arrangements.

Type Ia. A simplification of very frequent occurrence is caused by the vanishing of the *setae dorsales*, the *seta poststigmalis* at the same time coalescing with the *seta infrastigmalis*. The result is a single series, in which the stigma also takes its place. This pattern, which at first sight seems to possess a primitive character, occurs

e.g. in *Saturnia pavonia*. The original tubercles are here, even in the newly hatched larva, changed into verrucae and in the later instars into scoli. The only exception is seta dorsalis on the prothorax, which remains a single seta (fig. 3).

Type Ib. A final stage, almost identical with the former is found in *Lymntridae* = *Liparidae*. But here it is not the subdorsal seta or verruca which disappears, but the *dorsal* one. The *poststigmatal verruca* associates with the *suprastigmatal* one, but not completely, as even in full grown caterpillars the original duplicity remains perfectly visible, the two halves being divided by a furrow (fig. 4).

Type II. At first sight meso- and metathorax seem to possess a setal pattern different from that on the segments of the abdomen (fig. 5).

If we draw a line over these thoracic segments which crosses the stigmata of prothorax and abdomen, three setae on each of these segments are found above it, arranged in a vertical series. This group of setae is near the oral border of the segments. I consider them to be the *dorsal*, *dorsolateral* and *suprastigmatal seta*.

Nearly in the same series the *seta prostigmatalis* is found, as is clearly proved in those cases where a vestige of the stigma is present.¹⁾ Then the rudiment lies near the caudal border of the segment in the same position as the stigma of the prothorax. Sometimes it is represented by a pigmented spot (*Porthesia chrysorrhoea*, *Zeuzera pyrina*) or by a verruca (*Arctia caja*, *Sericina telamon*) and in other cases the tracheal system is visible through the skin and shows a distinct inflation on the corresponding place (*Pieris brassicae* and *P. napi*). Beneath the prostigmatal seta the *infrastigmatal* one, and in some cases the *basal* ones are found. As all these setae are arranged in a row, the type of their arrangement seems to be exceedingly simple.

By the above mentioned writers these setae are homologized in very different ways, as is demonstrated by the tabulated survey, given by FRACKER on page 40.

In comparison with the abdominal, this *type II* in the first place shows a reduction, by the suppression of the *superior* and *inferior subdorsal setae*. The former however sometimes remains visible. (*Pieris napi*). Moreover the *poststigmatal seta* is generally absent.

I explain this reduction as a consequence of the situation of the stigma near the caudal border of the thoracic segments, which hindered the complete development of the posterior row of setae. I hope to give full details in my next paper.

¹⁾ Even when this vestige is the wing "anlage" the seta s. prostigmatalis remains.

On the other hand meso- and metathorax generally show the *dorsolateral seta*, which is missing so often on the abdomen. This seta I consider as a primary one, for it not only occurs on nearly all thoracal segments, but it is found also on the abdomen in widely diverging families (e.g. *Phalera bucephala*, *Pieris napi*, *Hepialus spec.*). In the two last cases I could not detect it in the first instar, but it did occur in the more advanced. Yet QUAIL mentions this seta in the first instar of *Pieris brassicae*, where I failed to see it. The most remarkable circumstance however in connection with this seta is the occurrence of a pigment-spot on the pupae and imagines of Pierids exactly in the position where one might look for the seta, being even present in those cases, where during the last larval instar the setae become irregularly spread over the segment and are not surrounded by a considerable amount of pigment. It is on account of these arguments that I feel justified in considering the dorsolateral seta as a primary one.

I could amplify the outcome of my investigations with the results obtained by the writers mentioned before. Though they sometimes appeared to be in contradiction with my conclusions, in my opinion they really support them.

In the following survey of the types occurring in different families of Lepidoptera, the latter ones are arranged according to SHARP's handbook:

Of Rhopalocera *Nymphalidae* I studied *Vanessa urticae* L. For this family WIL. MÜLLER gives a primitive design, consisting of setae in *instar I*, yielding their place later on to a pattern of spines which shows a corresponding arrangement. The species I studied possessed from the beginning, besides common setae, a number of spines. These according to my theory may be indicated as follows (on the abdomen): the dorsal, suprastigmal and infrastigmal scoli and besides these in the form of simple setae, the subdorsal and poststigmal. Where such a close similarity existed with the primitive pattern, a real homology might be anticipated. Yet, for a number of S.-American forms, W. MÜLLER observed that these scoli were the product of the transformation of secondary setae, spread amongst the primary ones. So the above mentioned similarity would be incidental; but in agreement with MÜLLER the original nomenclature may be maintained.

In the kind of *Vanessa* which I studied, primary setae were almost completely absent.

As to the question, whether the pupal pattern must be reckoned to the primary or to the secondary design, I have not as yet arrived

at a definite conclusion. Judging from the pupal design of other Rhopalocera, a return to the primitive pattern of the first instar seems highly probable. With each following ecdysis the form of the scoli becomes more complicated, as MULLER has already observed. On the pupa of Vanessa (figured by J. F. v. BEMMELEN in 1912) a small spine occupies the place of the dorsal scolus, while the positions of the dorsolateral, suprastigmal, infrastigmal, basal and pedal scolus are indicated by pigment-spots. It deserves attention that in the larval stage the dorsolateral scolus is not present on the abdomen.

The *Pierids* in their first instar show the primitive pattern very completely. In the course of larval development great secondary changes take place by the multiplication of the number of setae and the formation of larger and smaller chitinous plates (called chalazae by FRACKER), which often bear a great number of setae. FRACKER denies their correspondence with primary setae, but in this he is mistaken. I have convinced myself that as far as the 3rd, and sometimes even the 4th ecdysis, the primary setae can be sharply distinguished from the secondary. The correspondence of these larval setae with the pattern of pupa and imago has been pointed out by J. F. v. BEMMELEN. Over and above these pigment-spots which can be brought in connection with primary setae, a spot is also found, corresponding to the dorsolateral seta.

Papilionid-larvae in their first instar were not at my disposal. The drawings of GRUBER (1884) however teach us, that amongst others in *Papilio philenor*, *instar I*, simple setae occur arranged according to *type I*. In succeeding instars, they are converted into scoli, growing more complicated with each ecdysis; in other species this change occurs during the first instar. *P. ajax* shows setae which bifurcate at their top, the same is mentioned by W. MULLER for different *Vanessids*, by SHARP for a few *Pierids*. In the ontogeny the dorsal setae disappear first, all the remaining setae follow this example successively.

Unpublished drawings of J. F. VAN BEMMELEN from specimens of *Papilio podalirius* in the collection KALLENBACH (now in the Groninger Zoological Laboratory), showed me, that the pigment-spots of the fullgrown caterpillar are arranged in a well characterized pattern. As far as I can judge they correspond with the dorsal, suprastigmal, superior and inferior subdorsal, pro-, post- and infrastigmal seta. Especially remarkable is the presence of the inferior subdorsal and prostigmal spot, which I did not perceive in the illustrations of the first instar. On the pupa of *Papilio machaon* (drawn by VAN BEMMELEN 1912), a tubercle marks the position of

he dorsal verruca. Between the stigma and the said tubercle two spots occur, representing the dorsolateral and suprastigmal verruca. Thus here again we find a dorsolateral on the pupa, which is absent on the abdomen of the caterpillar. For the rest, spots are found on the pupa agreeing with the prostigmal, poststigmal, anterior and posterior basal and often with the pedal verruca.

Summarising I may say, that in Rhopalocera during the first instar, *type I* is found on the abdomen. Afterwards three different changes may take place. Either the pattern gets complicated by the formation of verrucae, scoli or chalazae, or the setae, growing more numerous, spread over the surface of the segment in a homogeneous manner, or they disappear altogether. In all cases the primitive pattern comes back with the pupal stage, amplified by a dorsolateral spot on the abdomen as well as on the thorax. (cf p. 32).

Of *Heterocera* I studied the following families:

Saturniidae (fig. 3). As early as *instar I* *Saturnia pavonia* L. shows pattern *Ia* and this remains unaltered in sequence. The verrucae, which are present in the beginning, later on develop into scoli. On the prothorax the subdorsalis only remains a seta, but by its presence it justifies the supposition that the corresponding setae on the remaining segments have secondarily vanished.

Bombycidae. *Instar III* of *Bombyx rubi* shows a distinct arrangement of verrucae according to *type I*, but later on this pattern is quite wiped out by the great increase of the number of verrucae, which at the same time become irregularly dispersed.

During the first instar *Bombyx mori* is exclusively ornamented according to *type I*, the subdorsal seta being simple. In the following ecdyses this pattern is rendered indistinct by a homogeneous dispersal of setae, but it may, though not without trouble, still be recognized up to the last larval instar, in contradiction with the inference of FRACKER (p. 102).

Sphingidae. Characteristic of this family during *instar I* is the absence of the poststigmal seta on the abdominal segments, a seta prostigmalis at the same time being present, while the dorsolateral seta only occurs on the thoracic segments. In *Sphinx ligustri* this design is very distinct, in *Smerinthus tiliae* only a few setae are missing, while at the same time a number of shorter setae are found dispersed in a homogeneous way amongst the primary ones. In *Smerinthus populi* during the first instar only a scanty rest of the primitive setae is present. In the latter genus the secondary setae show a highly remarkable shape. Their height is $\pm 50 \mu$, and near the top they split up into a number of branches; the whole thus

producing the impression of an umbrella turned inside out by a storm. The Sphingid horn takes its origin beneath the dorsal seta of the eighth abdominal segment. WEISMANN, in his treatment of the colour pattern, gives only a few words to the setae and cites a species of Sphingidae which keeps them during the whole of its life. But, as he does not consider the setae as a part of the design, he does not give much attention to them. In the above-named species the setae disappear after the first ecdysis.

As long as I have not discovered intermediate stages, I cannot feel convinced by FRACKER'S assertion (p. 126), that the prostigmal-seta corresponds with his η , which is usually located beneath the stigma, the infrastigmal at the same time answering to x , which in other cases stands behind the stigma. In my opinion no proof whatever for such a rotation through an angle of 90° can be adduced.

Notodontidae. I carefully investigated all instars of *Phalera bucephala*. During the first instar a pattern of single or sometimes double setae was present, which accorded to *type I*. The double setae occupying the place of the dorsal might be supposed to be the result of a coalescence of this last with the dorsolateral. During following instars, up to the fourth, this pattern remains practically unmodified, but then the simple and double setae change into verrucae, which, however, maintain the same arrangement. Further the number of pigment spots increases after every ecdysis; especially along fore- and hind-margin of the segment. These spots unite with the accumulation of pigment in the verrucae and in this way horizontal lines are formed, running along the whole body. This is the only case in which I have been able to trace the origin of stripes, in all others they appear without any preliminary phenomena.

Cossidae. A full-grown larva of *Zeuzera pyrina*, a species which in the imaginal instar displays a highly primitive wing-design, showed on its abdomen *type I* but without a seta dorsolateralis on the anterior border of the stigma, a small seta is found only a little higher up than the usual position of seta prostigmalis (fig. 7). Yet I take it as such in contradistinction to FRACKER, who called it ϵ (my s. supraprostigmalis). The seta above the stigma, which I call s. supraprostigmalis is named by him ϕ . According to his system however seta ϕ belongs to the caudal series, i.e. beneath the subdorsal seta. Such an interpretation of the arrangement I can only regard as decidedly artificial. QUAIL found in *Cossus* a similar arrangement, he calls the seta prostigmalis III B.

Hepialidae. SHARP places this family after the Cossidae; many systematists, as is well known, unite it with *Micropterygidae* and

Eriocephalidae in the suborder of the *Jugatae*. I did not succeed in obtaining members of the two last mentioned families. As I said before, FRACKER was obliged to found his description of *Hepialus instar I* on a drawing by DYAR. The species which I was able to study, *H. hecta* L., differs in important respects from DYAR's *H. mustelinus*. The prothorax especially, to which FRACKER ascribes extraordinary importance, is decorated in quite a different style. On the abdomen (fig. 8) I found the dorsal, suprastigmal (right above the stigma), superior and inferior subdorsal (both lying in one line parallel to the caudal border of the segment), the poststigmal, infrastigmal, anterior and posterior basal, propedal and ventral setae. On the prothorax moreover the dorsolateral and prostigmal, but not the poststigmal and inferior subdorsal seta. Thus the pattern agrees almost completely with *type I*.

On a half-grown specimen of *Hepialus*-larva from the Duten village Boskoop, probably belonging to *Hepialus lupulinus*, the space above the prothoracic stigma was occupied by one seta only, which evidently was the superior subdorsal one, but the first abdominal segment carried the dorsal, dorsolateral and suprastigmal setae, all in one line above the stigma, and furthermore the superior and inferior subdorsal, the poststigmal, two infrastigmals, the anterior and posterior basal, the propedal and the ventral. If one wanted to derive the new second infrastigmal from the primitive pattern, it would be preferable to consider the anterior of the two as the real prostigmal. But before being able to give a solution of this question, it would be necessary to investigate the first instar of this species. FRACKER's explanation to regard the common poststigmal in this case as a typical subprimary seta ϑ , to call the posterior of the two substigmal setae χ , the inferior of the three suprastigmal ones ρ (which latter designation he uses in other cases for the inferior subdorsal) is in my opinion not in harmony with the facts. Moreover the presence at the same time of an inferior subdorsalis in the usual place, is in opposition to FRACKER's views.

QUAIL in this case as in the others calls the suprastigmal seta III B. I cannot agree with this view, as I am of opinion that this index should be exclusively bestowed on the prostigmal seta, as QUAIL does in the case of other larvae.

In considering the case of the *Hepialids* it should never be forgotten that however primitive a family may be, it nevertheless may have suffered certain secondary changes. This argument is for instance supported by VAN BEMMELEN's investigations of the colour-pattern on the *Hepialid* wings (1914, 1915, 1916) where he certainly

met with a primitive pattern, but at the same time established profound secondary modifications. Such an example warns us against the premature belief in the generality of a pattern, which was only seen on a prothoracic segment in one single representative of the family during the first instar. Especially as this not only should give us the generalized type of all Jugatae, but moreover should enable us to derive from it the generalized type of all Frenatae.

Not being able to dispose of complete materials, I must to my regret refrain from the investigation of pupae in Hepialids, larvae and pupae in Eriocephalids and Micropterygids. Judging by illustrations in textbooks, they seem to show very interesting setae and verrucae.

Thyrididae. In the collection KALLENBACH, which served as the basis of my work, the full-grown larva of *Thyris fenestrella* is represented by a mounted specimen. The abdomen bears simple setae, arranged according to *type I*, the poststigmatal seta only being absent. The thoracic segments possess moreover the dorsolateral and prostigmatal setae.

Lymantridae (= *Liparidae*). *Orgyia antiqua* L. is a remarkable form of this family on account of its long, strongly plumose setae. In succeeding moults they constantly grow more complicated, as PACKARD already mentioned (1889). In the main my results agree with his notations, except that we differ in the number of moults after which certain features of the pattern begin to show themselves. In the first instar the verrucae on prothorax and abdomen are arranged according to *type I*, those on meso- and metathorax according to *type II*. In the beginning the setae are not plumose, afterwards they become strongly so. In the course of its development the subdorsal verruca of the abdomen disappears in two ways: on the anterior two segments it unites with the dorsal verruca, on the remaining ones it shrinks and becomes obliterated. (fig. 4).

Porthesia chrysorrhoea passes in the main through the same course of development.

On the verrucae of *Ocneria dispar*, but in the first instar only, small setae, which in their middle thicken into a little globular knob, are spread amongst the larger ones. Afterwards they disappear, and this we find also in *Psilura monacha*. (WACHTEL and KORNAUTH 1893). The dorsal verruca sometimes remains visible during the whole larval period as a single seta or as a small wart. In the three last named species the setae, just as in *Orgyia* are not plumose during the first instar, but become so later on.

The agglomeration of the suprastigmatal with the poststigmatal verruca

has already been mentioned, when speaking of *type Ib.* (p. 528). In contradiction with the inference of FRACKER I observed this coalescence not only in *Ocneria (Porthetria) dispar*, but also in *Porthesia chrysorhoea*.

The pupae of *Ocneria dispar* are provided with verrucae bearing short setae with microscopic ramifications. Among the verrucae the following can be clearly made out: the dorsal (bigger than on the larva), the subdorsal, the suprastigmal (quite near the poststigmal, yet separated from it more distinctly than on the caterpillar), the infrastigmal, the basal and lastly a very prominent pedal.

Arctiidae. The verrucae are arranged according to *type I*, with only one exception, viz. the poststigmal, which has removed a little beneath the stigma, thereby somewhat displacing the infrastigmal towards the ventral side. I investigated *Arctia caja* and *Ocnogyna lubricipeda*, both showing simple setae during the first instar and feathered ones in the later. In contrast with the foregoing family the dorsal seta remains very large.

Geometridae. Only full-grown larvae were at my disposal. The primitive pattern, *type I*, was amongst others well shown by *Amphidasis betularia*. The setae are not plumose, the suprastigmal is placed a little more caudally than in other forms.

Noctuidae. In this family I was able to compare my results with FRACKER's schematic figures. We both came to the same conclusion: that in this extensive family the setae are transformed into verrucae, but sometimes return again to their primitive setose state. On the abdomen the primitive pattern seems to consist of the dorsal, suprastigmal (called by FRACKER in this case ϱ) the superior subdorsal, the post- and infrastigmal, one or two basals and the pedal. On the thoracic segments the prostigmal and dorsolateral are again added to them, the poststigmal is missing. Before and a little above the stigma a small prostigmal seta is found on the abdomen, which FRACKER takes to be ϵ (fig. 31 after *Feltia glandaria*) and QUAIL calls III B.

In *Acronycta psi* the fleshy prominence on the first abdominal segment has originated beneath the dorsal verruca, that on the sixth beneath the subdorsal one. In this species a prostigmal verruca is present, at least in the last instar.

In *Depressaria nervosa* (fullgrown specimen, coll. KALLENBACH) no setae are discernible except the dorsal seta on the mesothorax. On all segments however pigment-spots are seen in the same order as *type I* of the setal pattern. Here is therefore a new proof for the assumption, that *pigment spots may be homologized to setae, tubercula, verrucae, scoli, which is of eminent importance for the pupal design.*

Pyralidae, *Pterophoridae*, *Tortricidae*, *Tineidae* are not represented, as to their larval stage, in the collection KALLENBACH, no more so are *Eriocephalidae* and *Micropterygidae*. Judging from the drawings of FRACKER, they show the common *type I*, to which the inferior sub-dorsal and sometimes the prostigmal are added.

For the *Pterophoridae* O. HOFFMANN proved that some species possess setae, others verrucae, arranged according to *type I*. The deviations occurring in a few species can be easily brought back to the typical form, which in this case also includes the prostigmal seta. I am occupied with an investigation of this family, the results hitherto obtained harmonize with the above conclusions.

Taking all this together I feel justified in asserting that my *type I* can everywhere be recognized as the fundamental plan of the larval design. Up to the present time I have not succeeded in harmonizing this pattern with that occurring in other Insect-orders. The following groups would chiefly come into consideration in this instance. Blattidae (Spuler), Tenthredinidae, Trichoptera (Dyar), Panorpata (Handlirsch). Perhaps TOWER's excellent figures of *Leptinotarsa* may prove useful, but as yet these comparisons have not led to any satisfactory result.

Originally the pigment-accumulations agree with *type I*. Perhaps the linear markings are the result of spots, accidentally arranged in horizontal lines and meeting so as to coalesce, just as was actually observed in *Phalera bucephala*. As I could not obtain certain proof for this assumption, I prefer to reserve it until special investigations have brought the solution, and in the meantime to consider the *longitudinal stripes* as a new and independent element in the colour-markings, *acquired after the spots*, which for their part are bound to the setal pattern.

It is not surprising that the setal pattern in its primitivity or only inconsiderably modified is repeated on all segments of the body, with the exception of the two hinder ones, which also in other instances show great deviations from the general type. We consider it as a consequence of the strong homoiomery (= homonymy) governing the whole larval body. But an uninterrupted stripe, running in a longitudinal direction over a definite part of the segment, which part has become modified in consequence, is quite a different feature. Possibly those stripes which during the phylogeny have arisen step by step, as in *Phalera bucephala*, recede in the ontogeny to younger and younger instars. (WEISMANN). Yet it might fairly be expected, that when the stripe appears during the second instar for instance, it would be preceded during the first one by a series of isolated spots. This I could never detect. So the idea of mutations, by which

the stripy markings arose suddenly, remains open. The hypothesis of EIMER that stripes are more primitive than spots I feel compelled to reject.

Verrucae must have originated independently in the most different families, e.g.: Vanessidae, Pieridae, Papilionidae, Saturnidae, Bombycidae, Notodontidae, Arctiidae, Lymantridae, Noctuidae, Pterophoridae, Eriocephalidae. Therefore no systematic value can be attributed to their presence.

In a few families, e.g. Arctiidae and Lymantridae, which without doubt are nearly related to each other, plumose setae have been differentiated out of simple ones.

Homogeneous dispersal of setae (*Pieris napi*, *Bombyx mori*) and baldness (Papilionidae, Sphingidae) are both of secondary origin.

The Sphingidae occupy a peculiar position, in so far as a prostigmal seta is found on their abdomen, the poststigmal one being at the same time absent. I doubt the systematic value of this phenomenon, the more so, as I believe that in other families I have traced my prostigmal seta in ϵ of FRACKER or III B of QUAIL.

Finally a few words on the connection between larval and pupal markings. *Pieris napi* and *P. brassicae* are two nearly related species living under exceedingly similar circumstances. The former is remarkable for its protective, the latter for its terrifying colouring, as well in the larval as in the pupal stage.

The egg, the first larval instar, the pupa and the imago, resemble each other almost completely as to their colour-design, but the older larval instars become more and more different. In *Pieris brassicae* not only the number of setae goes on increasing, but the tubercles from which they spring grow in bulk and are strongly pigmented. Yet the primary setae remain distinct unto the last larval instar.

In *Pieris napi* the setae also get more numerous and the primary ones remain distinct during a certain period, but the secondary do not combine with the primary into larger groups. The point of fixation of the seta in the skin is but faintly pigmented and the striae, so conspicuous in *P. brassicae*, are reduced in *P. napi* to small specks in the neighbourhood of the stigmata. Now in the pupae the same spots, which were shown by the first larval instar, suddenly reappear.

In the case of *P. brassicae* this means that the pupa shows fewer spots than the caterpillar, a reduction in pigment-development therefore taking place. In *P. napi*, on the contrary, where the larva shows hardly any pigment-accumulations and the primary pattern has totally disappeared, this pattern also returns on the pupa.

In both cases there can be no question of a simple printing-over as POULTON suggested. VAN BEEMMELLEN's figures of the pupae of *P. brassicae* and *napi*, as well as those of *Euchloe cardamines* and *Aporia crataegi*, which two last do not any more than the two former possess a primitive design during the last larval stage, give satisfactory evidence that the pupal pattern in all four is identical. He likewise proved that a similar system of markings was to be seen on the body of the imago during its development inside the pupal sheath.

A remarkable fact in this connection is the occurrence of a pigmented spot on the abdomen, in the position where a dorsolateral seta might be looked for. This in my opinion, might be explained in two ways.

Either the *dorsolateral seta* is a primary one, which has usually vanished, but has remained on the thoracic segments and on the pupa.

Or, the dorsolateral seta is of a more recent origin than other primary setae and so manifests itself at a later stage on the abdominal segments than on the thoracic, as these latter are more advanced in their evolution. If this explanation is right, the pupa must be regarded as more highly developed than the first larval instar as regards the colour-markings.

The first assumption seems to me the more probable.

In any case the pupal markings are less complicated than those of the last larval instar and so provide us with an excellent example of convergent evolution.

The Hague, March 10, 1916.

Anatomy. — "*Some Observations on Periodic Nuclear Division in the Cat.*" By Mrs. C. E. DROOGLEEVER FORTUYN—VAN LEIJDEN.
(Communicated by Prof. J. BOEKKE)

(Communicated in the meeting of March 25, 1916.)

Introduction. After several authors had expressed their astonishment that so few mitoses occur in growing tissues, CHILD in 1904 ¹⁾ and 1907 ²⁾ and PATTERSON in 1908 ³⁾ have tried to explain this by refuting, on account of their own observations, the generally accepted view that mitotic nuclear division would be the only normal one.

CHILD studied the most various tissues of animals of diverse

¹⁾ Anatomischer Anzeiger. XXV.

²⁾ " " XXX.

³⁾ " " XXXII.

groups, growing as well as regenerating tissues and found many nuclei in them which divided amitotically. According to FLEMMING'S conception, which was especially supported by ZIEGLER and VOM RATH, this was only possible in pathological cases; according to CHILD it occurs in normal tissues as well, particularly when they are growing rapidly.

PATTERSON observed the same with the tissues of the embryos of the domestic fowl.

Without detracting from the accuracy of CHILD'S and PATTERSON'S observations I wish to point out here that still another viewpoint is possible which may perhaps in some cases offer an explanation of the small number of karyokineses in growing tissues.

It is a well-known fact that if one wants to see the cells of spirogyra dividing, these tissues must be fixed during the night.

Good observations of nuclear division in the rootlets of hyacinths and onion bulbs—a favourite botanical material—can be made if the rootlets have been fixed between ten and eleven in the forenoon. The question may now be put whether also in animal tissues a time may be fixed at which nuclear divisions are most frequent and next whether a period in the process of nuclear division can be noticed.

Material. To serve as material for the investigation six newborn cats were chosen from two litters and killed on the second day of their life respectively at 2½, 6½ and 10½ p.m.
and at 2½, 7 and 10½ a.m.

The following tissues were examined:

mesentery, (bits of which were spread on a slide), fixed with CARNOY stained with ironhaematoxylin-eosin;

cornea, fixed in mercury bichloride formalin, stained with ironhaem.-eosin and cut into sections of 5 μ .

small intestine, fixed with CARNOY stained with ironhaemat.-eosin and cut into sections of 5 μ .

liver, fixed with ZENKER'S liquid and stained with ironhaemat.-eosin, cut into sections of 5 μ .

Mesentery. Different pieces of the membrane were examined in succession and their nuclei counted by means of an "Okular-Netzmikrometer".

The following table shows the number of nuclear divisions and the various stages of the process of division.

Time of fixation	Number of nuclei	Spirema	Loose chromos.	Monaster	Diaster	Chrom. at poles	2 Young nuclei
10 ¹ / ₂ a.m.	3882	—	—	—	—	—	—
2 ¹ / ₂ p.m.	6106	13	1	—	—	—	—
6 ¹ / ₂ p.m.	4530	24	10	7	3	6	—
10 ¹ / ₂ p.m.	9972	13	25	25	13	31	—
2 ¹ / ₂ a.m.	7590	20	18	16	9	14	15
7 a.m.	9255	8	11	13	2	7	8

If we express in percentages the total number of dividing nuclei and the various stages and if we calculate the probable error by the well-known formula for it

$$m = \frac{\sigma}{\sqrt{n}} = \sqrt{\frac{\% p_0 \% p^1}{n}}$$

we obtain the following numbers.

Time of fixation	Percentage of all nuclei in state of division	Spirema	Loose chromos.	Monaster	Diaster	Chrom. at poles	2 Young nuclei
10 ¹ / ₂ a.m.	0.00	0.00	0.00	0.00	0.00	0.00	0.00
2 ¹ / ₂ p.m.	0.23±0.06	0.21±0.06	0.02±0.01	0.00	0.00	0.00	0.00
6 ¹ / ₂ p.m.	1.10±0.15	0.53±0.10	0.22±0.07	0.15±0.06	0.07±0.04	0.13±0.05	0.00
10 ¹ / ₂ p.m.	1.08±0.10	0.13±0.04	0.25±0.05	0.25±0.05	0.13±0.04	0.31±0.05	0.00
2 ¹ / ₂ a.m.	1.21±0.12	0.26±0.06	0.24±0.06	0.21±0.06	0.12±0.04	0.18±0.05	0.20±0.05
7 a.m.	0.53±0.07	0.09±0.03	0.12±0.03	0.14±0.04	0.02±0.01	0.08±0.03	0.09±0.03

The tables clearly show that there is a time of maximum and one of minimum nuclear division, the intermediate times forming a gradual transition.

At 10¹/₂ a.m. not a single division was observed; at 2¹/₂ p.m. in 6106 nuclei 14 karyokineses, i.e. from 0,17 to 0,29%. At 6¹/₂ p.m. the number has considerably increased, amounting to 50 in 4530, i.e. from 0,95 to 1,25%.

At 10¹/₂ p.m. the number of karyokineses is 107 in 9972, i.e. from 0,98 to 1,18%, pretty much the same number as at 6¹/₂ p.m. At 2¹/₂ a.m. the karyokineses number 92 in 7590, i.e. from 1,09

¹⁾ See JOHANNSEN, "Elemente der exakten Erblchkeitslehre". first edit., p. 82, 2 and 57.

to 1,33%, on the average a little more than in the two preceding cases. However, the numbers fall within the limits of probable error, so we may put the last three cases about equal.

At 7 a.m. the number of karyokineses has again greatly fallen. On 9255 nuclei there are 49 divisions, i.e. from 0,46 to 0,60%. The cycle is now complete and we are again at 10¹/₂ a.m. without a single karyokinesis.

We see from this that there is a maximum number of karyokineses during the evening and night at 6¹/₂ p.m., 10¹/₂ p.m. and 2¹/₂ a.m. and a total absence of karyokinesis at 10¹/₂ a.m. The intermediate hours, 2¹/₂ p.m. and 7 a.m. show a rise and fall.

Let us now see whether some regularity can be perceived in the succession of the various stages.

At 2¹/₂ p.m. — when the process of division may be considered to have just started — we only meet with the two youngest stages of division. At 6¹/₂ p.m. we find all stages except the last; the two youngest stages are most frequent. At 10¹/₂ p.m. we have the same stages as at 6¹/₂ p.m., the medium stages begin to prevail here. Remarkable is here the rise in the last stage but one.

At 2¹/₂ a.m. we find again several nuclei in the very youngest stage. However, we also see nuclei in the very last stage, namely 2 young nuclei. (It is not always easy to settle whether we have to do with 2 young nuclei. Only such cases have been mentioned in which the chromatine was still clearly visible as two lumps belonging together, as in the preceding stage, with this difference, however, that here no division-splindle and centrosomes were visible, as was the case in the last stage but one.) For 7 a.m. the same holds as for 2¹/₂ a.m.

Hence there is no perfect regularity in the process. At the later hours of the cycle a larger number of young stages occur than at the middle hours. But it is remarkable indeed that at the earlier hours, namely at 2¹/₂ p.m. only early stages of division are found and that at the later hours, 10¹/₂ p.m., 2¹/₂ a.m. and 7 a.m. the two last stages of division have greatly increased in number.

Cornea. Of the cornea the outer stratified epithelium was examined with regard to the number of karyokineses. A much smaller number of divisions was found than in the preceding tissue. This cannot be wondered at if it is borne in mind that the mesentery grows more rapidly than the cornea.

The following table (See p. 42) gives the required information.

Expressing again the total number of karyokineses in percentages and taking into account the probable error, we obtain the following figures: (See p. 42) .

Time of fixation	Number of counted nuclei	Spirema	Loose chromos.	Monaster	Diaster	Chrom. at poles	2 young nuclei
10 $\frac{1}{2}$ a.m.	3167	—	—	—	1	—	—
2 $\frac{1}{2}$ p.m.	3308	4	1	2	1	—	—
6 $\frac{1}{2}$ p.m.	2557	—	—	5	4	—	—
10 $\frac{1}{2}$ p.m.	3066	9	4	19	8	2	—
2 $\frac{1}{2}$ a.m.	4752	11	2	10	9	1	8
7 a.m.	2750	10	2	4	10	1	2

Time of fixation	Percentage of karyokineses
10 $\frac{1}{2}$ a.m.	0.03 \pm 0.03
2 $\frac{1}{2}$ p.m.	0.12 \pm 0.06
6 $\frac{1}{2}$ p.m.	0.35 \pm 0.12
10 $\frac{1}{2}$ p.m.	1.37 \pm 0.21
2 $\frac{1}{2}$ a.m.	0.86 \pm 0.13
7 a.m.	1.05 \pm 0.19

As in the first case we notice here a time with a minimum number of karyokineses and another with a maximum number.

The minimum occurs at the same time as in the preceding case, namely at 10 $\frac{1}{2}$ a. m. In 3167 nuclei I only met a single karyokinesis i.e., including the probable error, from 0.06 to 0.00%. The time of the maximum number is here at 10 $\frac{1}{2}$ p.m. At 2 $\frac{1}{2}$ a.m. a considerable decrease in the number of nuclear divisions is already noticed; at 7 a.m. a slight rise. If we take the probable error into account, however, we perceive that the limits of the numbers cover each other, the percentage at 2 $\frac{1}{2}$ a.m. being from 0,73 to 0,99, at 7 a.m. from 0,86 to 1,24.

At 2 $\frac{1}{2}$ and at 6 p.m. we have transitions from the minimum at 10 $\frac{1}{2}$ a.m. to the maximum at 10 $\frac{1}{2}$ p.m. Here also it is noticed that in the daytime the number of nuclear divisions is very small, during the night and in the early morning hours karyokinesis is not unfrequent. The time of the maximum number is here later than in the preceding case.

As to the various stages, no distinct succession can be noticed

here. It should be stated that the stages of nuclear division were not nearly so well visible as with the mesentery. It was often difficult to make out what stage was present. Still it may be remarked that also in this case the two last stages of the process (chromatin at the poles and 2 young nuclei) only appear during the later hours of the cycle.

Small intestine. Of the small intestine the epithelium of LIEBERKÜHN'S crypts was studied. It should be remarked at the outset that also in the adult intestine karyokinesis is always frequent. Still I thought that perhaps maxima and minima might be observed.

The following table shows that this is indeed the case. Since it was impossible to make out here what stage was present, only the number of karyokinesis was counted.

Time of fixation	Number of nuclei counted	Number of karyokin.	Percentage of the kar.
10 $\frac{1}{2}$ a.m.	3070	58	1.89 \pm 0.25
2 $\frac{1}{2}$ p.m.	3086	60	1.94 \pm 0.25
6 $\frac{1}{2}$ p.m.	3086	116	3.76 \pm 0.34
10 $\frac{1}{2}$ p.m.	3093	127	4.11 \pm 0.36
2 $\frac{1}{2}$ a.m.	3043	87	2.86 \pm 0.30
7 a.m.	3076	73	2.37 \pm 0.27

Distinct maxima are observed here at 6 $\frac{1}{2}$ and 10 $\frac{1}{2}$ p.m. (Here also both numbers lie again within the limits of the probable error). At 2 $\frac{1}{2}$ p.m. a decrease is clearly noticed; the minimum number of karyokineses is reached in the late morning hours and in the early afternoon. The lowest number is again observed at 10 $\frac{1}{2}$ a.m. although it cannot be stated, with certainty that this is the minimum, since the numbers of 7 a.m. and 2 $\frac{1}{2}$ p.m., as well as that of 10 $\frac{1}{2}$ a.m. lie again within the limits of the probable error.

So the case is somewhat different from that of the two first-mentioned tissues. Here we have a continuous process, but as in the two former cases the maximum of mitotic nuclear division lies here in the evening and night.

Liver. Finally preparations of the liver were thoroughly examined but without any result. Some very few distinct karyokineses were observed and many doubtful ones, but these were not such that a table of any trustworthiness could be based on them. Whether the

liver is really a tissue for which the above does not hold or whether the fixation had been insufficient I have been unable to settle.

Summarising we may state that for the mesentery, the outer stratified epithelium of the cornea and the epithelial cells of LIBBERKÜHN'S crypts of newborn cats a period in the mitotic nuclear division is observed with a maximum in the evening, the night or the early morning hours, a minimum in the later morning hours and the early afternoon. The maximum number of karyokineses does not always occur at the same time, but never in daytime, the minimum is always at the middle of the day.

Further investigation will perhaps reveal that also other tissues, as well of the cat as of other animals, show the same phenomenon and this may be the reason why in general in growing tissues no or very few karyokineses have been observed, since the fixation of the tissues has commonly taken place at the middle of the day.

*Anatomical Cabinet
Histological Department.*

Leyden, February 1916.

Physiology. — "*The electrical phenomenon in cloudlike condensed odorous water vapours*" examined by Prof. Dr. H. ZWAARDEMAKER in collaboration with Messrs. H. R. KNOOPS and M. W. VAN DER BIJL.

(Communicated in the meeting of March 25, 1916).

That odorous substances are often present in the air in the form of water vapours with a cloudlike condensation and in that state stimulate our sense-organ was first suspected by J. GAULE¹⁾ in the year 1900. A frequent occurrence of this phenomenon seems to me to be improbable²⁾, still, I felt called upon to look more closely at the sensory qualities of odorous water vapours with a cloudlike condensation, when a suitable apparatus to produce them should be at my disposition.

Such an apparatus was devised two years ago by Prof. G. GRADENIGO, who made use of a simple glass sprayer, of the adiabatic expansion of compressed air, supplied under an over-pressure of two atmospheres and of the splashing of the waterdrops against a glass wall³⁾.

¹⁾ J. GAULE in P. HEYMAN'S Hdb. der Laryncologie und Rhinologie. Bd. III p. 178 Wien 1900.

²⁾ Cf. my "Physiologie des Geruchs", p. 22. Leipzig 1895.

³⁾ The apparatus still used by us is the one Prof. GRADENIGO kindly made me a present of. A description of it will be found in Arch. int. de laryngologie, d'otologie et de rhinologie 1911.

Probably the following takes place: The rapid air-current draws up the water in which the substance to be examined has been dissolved. This water evaporates in the air which streams past and which has become ionized at the vertical nozzle, and saturates the air with water-vapour, provided, as in our case, an excess of water is present. Meanwhile the over-pressure of two atmospheres being reduced to zero, the air suddenly expands. A considerable fall of temperature ensues and a cloudlike condensation appears. The spray splashes against the glass wall and according to GRADENIGO and STEFANINI, what flies past it gives a cloud, which may be stored for a considerable period if the precaution has been taken to dissolve in the water a small percentage of common salt or of a mixture of salts. We were able to confirm GRADENIGO's and STEFANINI's experience to the full. Even the most various non-volatile substances, electrolyte or not, when dissolved in water, give a beautiful, dense cloud, which may be stored for hours in a Tyndall case.

If, however, instead of salt- or sugar-solutions we take aqueous solutions of odorous substances, which naturally are more or less volatile, the cloud is less steady and will disappear after some minutes. Even then we can note in the ultramicroscope fine water-drops close upon their formation, briskly performing BROWNIAN movements.

It appeared at once that the odour outlasts the cloud, in other words that an odorous substance, as might be expected, is noticeable not only and not invariably as a condensed vapour, but also in a purely gaseous state. A similar observation was made also by J. AITKEN in 1905, when he stated¹⁾ that odorous substances, in a space where ions are wanting, do not form clouds from over-saturated air.

However, another remarkable fact manifested itself. When a simple condensed water-vapour or a salt-containing cloud is driven against a metal plate, well-insulated, and connected to an electroscope, it will, under the experimental conditions, not be possible to render a charge visible. This is easy to understand, as according to STEFANINI electro-positive as well as electro-negative ions are present in the salt-nebula, apparently in equal numbers. When placed between two charged condenser discs, the vapour clarifies, though it remains, while the somewhat larger ions are drawn to the positive, the somewhat smaller to the negative disc.

If, on the contrary, we took an odour-containing condensed vapour,

¹⁾ J. AITKEN, Proc. Roy. Soc. of London. Vol. 25, p. 894. 1905.

and allowed it, though being unstable, to flow against a metallic disc even from some distance, we discovered a very strong charge, which, of course, under the experimental conditions (overpressure of two atmospheres), was invariably a positive charge. While the cloud diffuses after the flow is arrested, the charge is left behind on the electroscope. The surrounding air is evidently not more conductive than it would be without a vapour. Also the drops creeping down the disc appear to be charged, the charge being under the experimental conditions invariably positive.

The literature contains previous reports of vapours disposed to condense in the shape of drops round the positive ions as their nuclei ¹⁾. We know now that in the cases here referred to, which were few and far between, the experimenter used substances of some olfactory quality. This induced us to examine all odorous substances at our disposition with a view to their electrical effect.

First of all we examined the odorous solids at hand, as I felt inclined to generally identify the phenomenon observed by us with the so called odoroscopic phenomenon ²⁾. Then our researches were extended to odorous liquids in aqueous solution. Seemingly insoluble substances were mixed with water in a separator; the fluid was subsequently filtered and the filtrate sprayed under an overpressure of two atmospheres into an inconstant vapour ³⁾.

Electrification was detected with: acetaldehyd, acetone, ether, ethyl-alcohol, ethylbisulfid, ethylbromid, ethylbutyrate, ethylmelonic acid, allylsulfid, ammoniac, amylacetate, amylalcohol, amylbutyrate,

¹⁾ Cf. H. KAMERLINGH ONNES and W. H. KEESOM, *Enc. d. meth. Wissenschaft* V. 10, p. 910, note 937, which brings up the literature to 1912.

²⁾ The odoroscopic phenomenon has been discovered by VENTURI was named after him, studied again by PRÉVOST and extensively investigated by LIÉGEAIS. (*Arch. de physiol.* 1868 t. I p. 35). VAN DER MENSBRUGGHE (*mém couronnées par l'acad. royale de Belgique* t. 34 1870) correlated it with a lowering of the surface tension. MARCELIN (*Ann. de phys.* t. IX, p. 14 1914) found that by covering the evaporation and consequently the movement was stopped. A satisfactory method to obtain a perfectly pure, fat-free water surface has been suggested by RÖNTGEN. For the theory see Lord RAYLEIGH *Sc. papers*. Vol. 3, p.p. 347 and 383

³⁾ The phenomenon of electrification affords a very sensitive reagent to find out whether any part of an odorous substance dissolves or not; in this respect it is comparable to the olfactory sense. Therefore, the vessels must be kept perfectly clean and control tests with pure water must continually be inserted. The amount of electricity conveyed by the vapour to the electroscope is astonishingly great, much greater than the electricity generated by the splashing of water (LENARD). A full discussion of electrification through transformation of liquid surfaces into gases was brought forward by A. BECKER in *Jahrb. der Radioactiv. u. Electron.* Bd. II, p. 42. 1912.

anethol, anilin, anisaldehyd, apiol, acetic acid, benzaldehyd, borneol-bromin, bromoform, isobutylalcohol, carvone, chinolin, chloroform, cinnamylaldehyd, citral, citronellol, cumol, decylaldehyd, duodecylaldehyd, eucalyptol, eugenol, formaldehyd, guaiacol, heliotropin, ionone, iron, iodin, linalool, menthol, mercaptan, methylantranilate, methylbutyrate, methylsalicylate, formic acid, myrtol, naphtalin, nonylaldehyd, paraldehyd, paraffin-ether, propylamin, pulegon, pyridin, safrol, skatol, styron, thymol, trimethylamin, undecylaldehyd, valerianic acid, vanillin, xylol.

As yet we did not come across any exception among the true odorous solids.

All odorous vapours charge a metal or glass wall positively, when it is placed in their way. With the true odorous solids ethylmelonic acid, benzaldehyd, citral, eugenol, geraniol, heliotropin, ionon, camphor, menthol, trinitrobutyltoluol, (artificial moschus) this effect can be produced even in extremely weak dilutions. With other substances the charge is less strong, sometimes weak. With ammoniac it was so weak that we almost supposed we had to do with an exception. However, even with this substance a positive charge is not altogether wanting. Aqua chlorata does not electrify appreciably. No more does ozone-containing water.

Of course, the question arises where the other charge is located. It may be rendered visible by replacing the disc by a wire gauze. This shade will be charged positively, while in the cases examined, the negative drops fly through it and are caught up on a disc drawn up behind the shade. The positive drops streaming down the shade emit a stronger scent than the negative ones collected on the disc.

It seems to me that what we have observed so far may be explained as follows:

Suppose that somewhat larger drops form round the positive ions than round the negative, then the smaller negative drops will, in the case of odorous watervapours, evaporate sooner and thus leave the negative nuclei denuded.¹⁾

These negative nuclei will slip through the meshes of the wire

¹⁾ Also when we take odorous paraffin a spraying occurs, though not through condensation. The dense cloud then forming is again electro-positive, and continues for some time. The cloud smells of the substance dissolved in the paraffin, of tallow if the paraffin be pure. In this case the odour can volatilise from the drop, but the drop itself cannot evaporate.

An odorous substance dissolved in glycerin does not give a charge, unless the solvent is diluted with three times its volume of water.

gauze, whereas the large positive nuclei, loaded with waterdrops, dash against the disc and creep down along it. Also in GRADENIGO's and STEFANINI's experiments with salt-clouds the larger drops splash against the glasswall and the smaller escape to the inhalatorium.

With their salt-clouds, contrary to our odour-containing vapours, however, the positive charge cannot be rendered visible on an intercepting disc, though both positive and negative charges can, also with salt-clouds be demonstrated when another method is employed viz. through special contrivances.

In what we have said above we assumed that the odour-containing water condenses round the negative as well as round the positive ions, also, however, that the former disappear sooner, because the drops evaporate more rapidly. It goes without saying that we may also assume the vapour to condense, under the experimental conditions, only round the positive ions. (See the above references to the literature).

The excess of charge in odorous cloudlike condensed vapours is in every sense the counterpart of the odoscopic phenomenon (camphor movement on perfectly pure water), as it requires for its arousal:

- 1st. volatility of the substance ;
- 2nd. an effect of reducing the surface tension of the water.

The phenomenon of electrification is, however, more general, as it applies to odorous liquids as well as to odorous solids, that are soluble in water, whereas the odoscopic phenomenon holds only for the latter.

Special attention should be given to the fact that a 2% alcohol-solution, when sprayed, gives a distinct charge, which gradually diminishes with 5%, 10% and 25% solutions, the latter giving only a trace, while a 50% solution gives no charge at all. A similar ratio with slight differences in the percentages is found in the case of acetone, pyridin and a number of other substances examined on this point.

Even surprisingly small quantities of true odorous substances suffice to generate electricity as e.g. 25,10⁻⁶ grms of geraniol taken up in 25 c.c. of a 2% salicylas natrius solution (giving no charge of itself), is sufficient to produce a distinct charge. A similar result is obtained with a quantity of trinitrobutyltoluol (artificial moschus) of the same order. Such liquids have (as determined after TRAUBE) a lower surface tension than water. If we bear in mind that the 25 cc. of liquid were diffused in a large volume of air, it is easy to realize how vivid the electrical reaction is. Still it is far distanced

by the sensory reaction of smell (of trinitrobutyltoluol e.g. 1.10^{-16} mgrms is distinguishable in one litre of air). In the present experiments we purposely used a rather sensitive electroscope. Our first care was insulation and the avoiding of sources of errors. It is, therefore, not out of the bounds of probabilities that for judiciously selected and very sensitive instruments the electrification-phenomenon and the sense organ will appear to vie with each other in giving the reaction. Apart from experimental conditions, the small quantity of the substance, manifesting itself by virtue of electrification is, as I think, dependent on molecular weight, on volatility and on a lowering effect upon the surface tension. They are the very factors constituting the physical conditions that must be fulfilled by a substance to act biologically as an odorous substance.

Anatomy. — “*On the determination of the position of the macula-planes and the planes of the semicircular canals in the cranium*”.
By Dr. H. M. DE BURLET and J. J. J. KOSTER. (Communicated by Prof. H. ZWAARDEMAKER).

(Communicated in the meeting of April 28, 1916).

§ 1. In order to be able to give an exact determination of the position of the macula-planes and the planes of the semicircular canals in the cranium, a first requirement is to connect the situation of these planes with fixed data taken from the cranium, which can easily be found again in each specimen. Absolute value cannot be assigned to the most exact determination, because the data taken from the cranium are always liable to variation; such a determination must therefore always be taken as an individual one.

By comparison of found sizes with different individuals of one and the same species, an impression may be obtained about the variation and an average position can be approximated.

The following refers to the rabbit, on whose cranium-basis we have fixed a line by two points, which points can easily be traced in each rabbit-cranium. The situation of these points moreover being so, as to enable us to demonstrate them accurately in series-sections. Pl. I shows the rabbit's cranium-basis seen from above. An imaginary line *a b*, connects the Incisura intercondyloidea (*a*) with a little spina (*b*), which regularly appears at the proximal end of the basi-occipitale. This line, which is the starting-point of our determinations, is almost conform with the line of intersection of the

‡

Proceedings Royal Acad. Amsterdam. Vol. XIX.

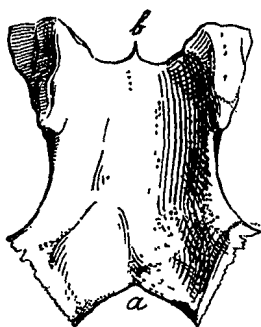

Pl. 1. The basi-occipitale of the rabbit seen from above.

medium plane, with the top-level of the basi-occipitale. This last description is to be regarded as an aid to orientation; with the presently following determinations the imaginary line *a*, *b* (cranium base-line) only plays a part.

In order to determine the position of any plane in the cranium (e. g. a maculaplane) two angles must be known, viz.:

1st. the angle, which the desired plane forms with the medium plane,
 2nd. the angle between cranium basisline and the line of intersection of the planes mentioned under 1. Thus we can first of all determine the position of the four macula-planes and that of the six planes of the semi-circular canals in the cranium.

Moreover it is important to know the mutual position of these planes, i. e. we must try to find the angle:

α , between the two planes of the posterior semicircular canals (Plane of posterior canal left and right *PPCL* and *PPCR*),

β , between the two planes of the superior semicircular canals (*PSCL* and *PSCR*),

γ , between the two planes of the exterior semicircular canals (*PECL* and *PECR*).

I *R*, between the planes of the superior and the exterior semicircular canal on the right (*PSCR* and *PECR*).

II *R*, between the planes of the posterior and the exterior semicircular canal on the right (*PPCR* and *PECR*).

III *R*, between the planes of the posterior and the superior semicircular canal on the right (*PPCR* and *PSCR*).

I *L*, between the planes of the superior and the exterior semicircular canal on the left (*PSCL* and *PECL*).

II *L*, between the planes of the posterior and the exterior semicircular canal on the left (*PPCL* and *PECL*).

III *L*, between the planes of the posterior and the superior semicircular canal on the left (*PPCL* and *PSCL*).

UU, between the Utriculusmacula-planes (*UL* and *UR*).

SS, between the Sacculusmacula-planes (*SL* and *SR*).

SUR, between the planes of Macula utriculi and Macula sacculi on the right (*UR* and *SR*).

SUL, between the planes of Macula sacculi and Macula utriculi on the left (*SL* and *UL*).

§ 2. We now come to the question, how to obtain the knowledge of the desired data. Various attempts have been made to define the angles between the macula-planes and the planes of the semicircular canals, by direct measuring either on casts from the labyrinth, or on enlarged models of it. We shall more fully refer to this elsewhere. Suffice it to say, that according to our opinion, the question put here, first of all lends itself to a mathematical treatment, as it guarantees a great deal of accuracy. Let us first discuss that which refers to the position of the planes of the semicircular canals, later on that which refers to the position of the Macula-planes.

A. *The planes of the semicircular canals.*

The first difficulty which offers is that a plane of a semicircular canal in general does not exactly lie in one level. Apart from the thickness of the tube, the semicircular canals show a divergence from the level plane, which may perhaps best be indicated by the term "swaying". In our determination no account has been taken of this factor however; we have been contented with characterizing a plane of a semicircular canal by taking three fixed points. ¹⁾

Two of these points coming into consideration for the determination of the plane of the semicircular canal are obvious, they are:

point a , the place where the semicircular canal runs into the utricle,

point b , the place where the ampulla narrows into the actual semicircular canal.

The third point (c) must be determined on the circumference of the semicircular canal. In order to get to work systematically, this point was taken at an equal distance from a and b , with all semicircular canals, measured on the circumference.

In Pl. 2 a semicircular canal is shown; the plane through the points a , b , and c of this semicircular canal is plane S . Plane S cuts the interperpendicular planes of projection of P_1 , P_2 , and P_3 along the lines S_1 , S_2 , and S_3 .

The distances between the points a , b , and c to the three planes of projection (being the projections from a , b and c) are known, as will be expounded later on. This enables us to determine the passages of plane S , by means of the method usual in descriptive geo-

¹⁾ Greater accuracy may be obtained in this respect. With the aid of analytic geometry one can attain the determination of a plane, which takes into account the swaying of the semicircular canal and consequently gives us the position of it more accurately.

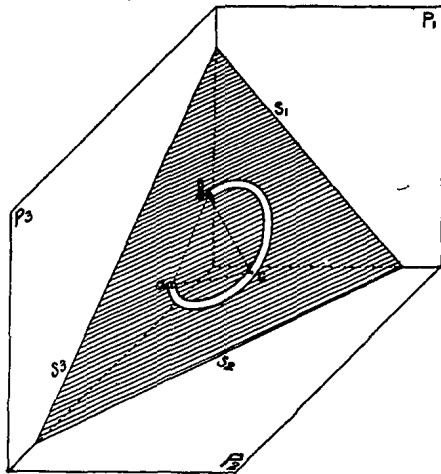

Fig. 2.

metry. It would take us too far to expound such a construction here, it can be found in any book on descriptive geometry. For explanation see Pl. 3; 3a shows a three dimensional representation conform to Pl. 2 in which the projections of the points *a*, *b* and *c* are also indicated, whilst in Pl. 3b the projections and the passages have been put down in one plane.

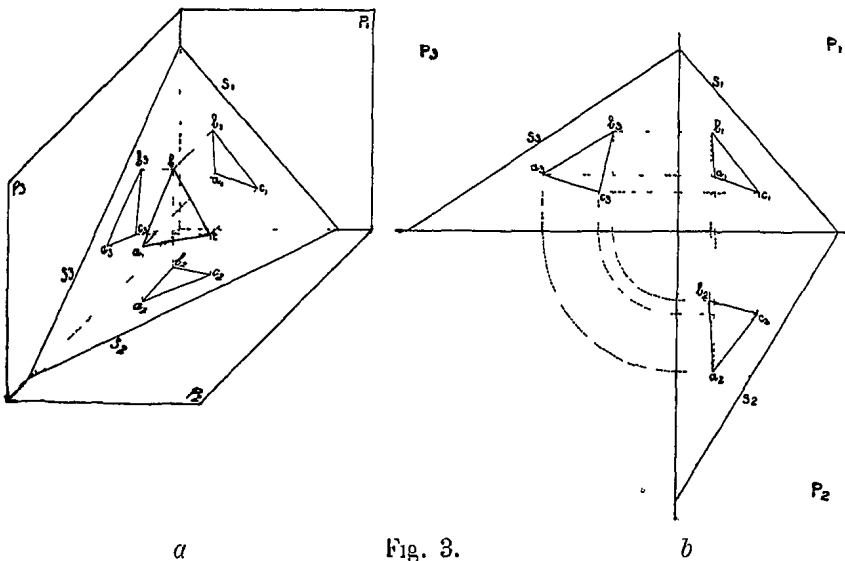

Fig. 3.

Projections of the points of definition and of the passages of a semicircular canal.

The passages of a second plane of a semicircular canal in the same system of projection having been determined according to this method, the angle between these two planes of semicircular canals can be construed and measured in the way usual in descriptive geometry. Pl. 4a and 4b, reproduce the mode of construction of the angle

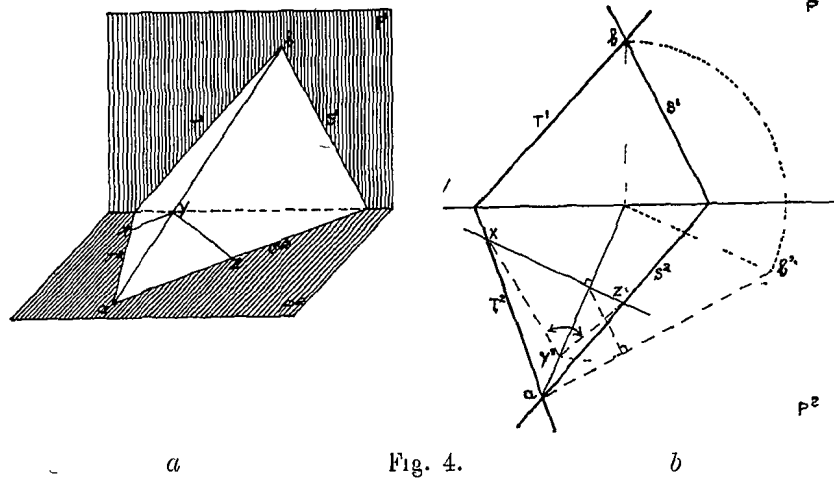

Fig. 4.
Construction for the determination of the angle between two planes cutting one another.

between two planes.

Making use of the same system of projection we are thus able to construe not only two, but all six planes of semicircular canals and to measure the angles α , β , γ , I R, II R, III R, I L, II L, III L (see page 2).

As we now know the angles, which the planes of the semicircular canals form between them, there still remains to be determined, the position of the planes of the semicircular canals in the cranium. As has been expounded this required the knowledge of:

1st. the angle made by a plane of a semicircular canal with the medium plane,

2nd. the angle between the cranium basishne and the intersecting line of the planes mentioned under 1.

The method we have been following up to now, has made known to us the size of the angles α , β and γ , these are the angles formed by conformable planes of semicircular canals, on the right and on the left. In the case of absolute symmetry, the medium plane must be a plane that cuts the angles α , β and γ into two; in other words the half of the values found above for the angles α , β and γ represents the size of the angle asked under 1st.¹⁾

We know the projections of both points of definition of the cranium base-line, just as we likewise know the projections from the points a , b and c of the semicircular canals, which will be discussed more in detail.

¹⁾ The question as to how far we can admit the existence of a perfect symmetry between the right and left labyrinth will be discussed in a detailed article on this subject to be published later on.

The construction of the angles α , β and γ , made us find the lines of intersection of conformable planes of semicircular canals, lying in the medium plane, on the left and on the right. In order to find the angle mentioned under 2nd, the construction must still be made, leading to the measuring of the angle formed by those two lines; thus making this question a simple problem of descriptive geometry. But now comes the question: how to get our planes of projection. Before entering upon this subject it will be necessary, to mention some technical details about the treatment of the objects.

The material examined consisted of three rabbits, treated in the following way:

The recently killed animal was rinsed from the aorta with MÜLLER'S liquid.

The back part of the cranium (including the hypophyse; the cranium-roof remained intact, the brains were removed) was then treated according to WITTMACK'S method¹⁾, but this exception that the bone was decalcinated after the impregnation in celloidine. The decalcination in the celloidine offers the advantage, that no removal of the labyrinths with regard to each other can take place. In first decalcinating and consequent enclosing, mistakes caused by removal may take place. The celloidine-block was consequently fastened on the microtomé, in such way as to make the direction of the cut an almost frontal one. The sections made at the first beginning do not contain the object yet.

Before the object appears in the sections, a plane has been formed on the celloidine-block, being the plane of the direction of the cut, which remains the same all through the further manipulation. Round canals were bored perpendicularly in the celloidine-block on this plane, which canals appear as round holes in every section. This was obtained by placing a brass block bored by canals, on the plane of the direction of the cut. A hollow needle pierced through these canals into the celloidine-block gets the direction of the canals in the brass block, these canals being made in such a way, as to cause them to stand perpendicularly on the base, in other words the canals made in the celloidine-block stand perpendicularly on the plane of the direction of the cut.

Pl. 5 schematically sketches six sections lying on top of each other, e.g. 25 \times enlarged. P_3 is a plane through the axis of two bored canals. P_2 is the plane on which the sections lie (the plane of the direction of the cut) P_1 is a plane standing perpendicularly on P_3 and P_2 .

¹⁾ Zeitschrift für Ohrenheilkunde. Bd. 51. bldz. 148.

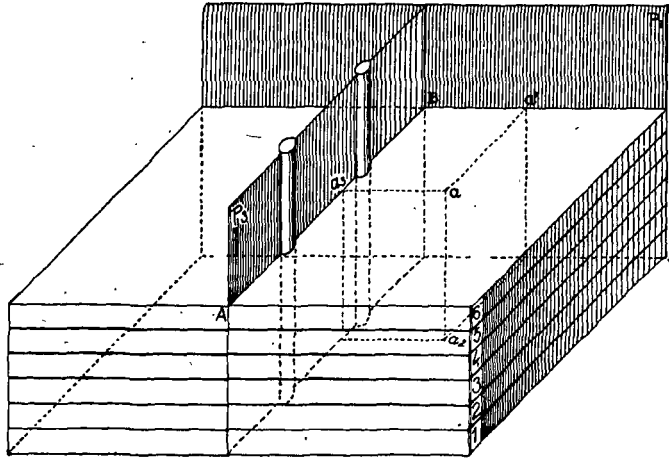

Pl. 5. Explanation : See text.

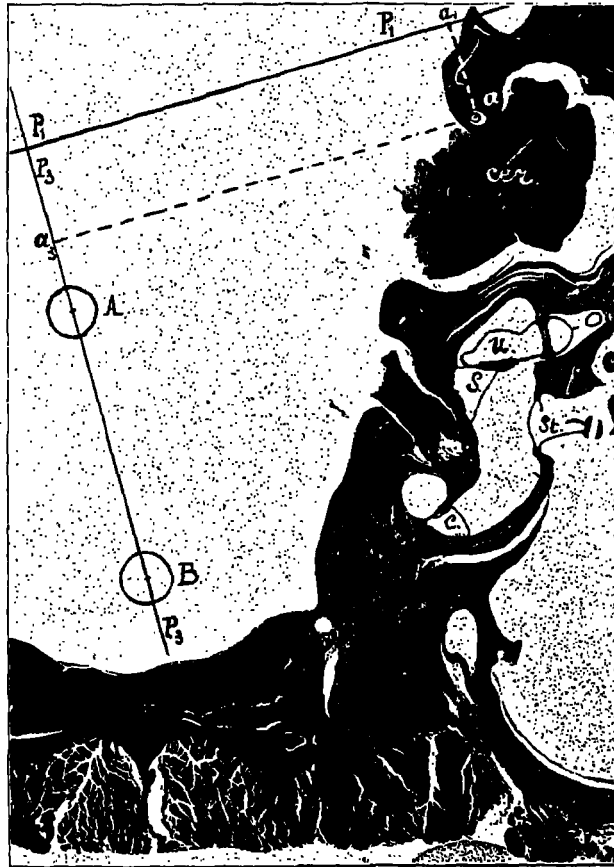

Pl. 6. Part of cut 211. Series Ia a point of definition of a Semicircular canal. U. Utricle. S. Sacculle. C. Ductus cochlearis. Cer. Cerebellum. f. Nervus Facialis. St. Stapes.

Pl. 6 shows part of the top section shown in Pl. 5. The circles *A* and *B* are the sections of the bored canals. Line P_2P_3 connecting the centres of these circles is the line of intersection of Plane 3 with the plane of the direction of the cut, while line P_1P_2 shows the line of intersection of Plane 1 with the plane of the direction of the cut. If point *a* (pl. 6) is a point of definition of a semicircular canal, the ordinates of this point aa_1 and aa_2 can be easily determined, viz. by direct measuring. The ordinate aa_2 depends on the number of the section in the series, its size is determined by the thickness of the sections and the degree of enlargement. (See Pl. 5).

It will be easy to understand now, that in this way, not only from a point *a*, but also from 18 points, being 6×3 points of definition of six planes of semicircular canals, the ordinates, with regard to the planes P_1, P_2 and P_3 which are used as planes of projection, can be determined.

By means of the projections of these 18 points 6 planes can be construed, according to the method of descriptive geometry and the angles between those planes can be measured, conformable to the description given above.

B. *The planes of the otoliths.*

In order to determine the position of the planes of the semicircular canals, it has proved necessary to neglect one property viz. "the swaying". Similarly when determining the position of the planes of the otoliths, it must be kept in view, that these planes do not exactly answer to the membranes of the otoliths. A factor of curvature is neglected here as well, the sacculus and the utriculus-otolith-membranes viz. both forming curved planes, which are hard to represent in our calculation. What has been described as the otolith-membrane here, is consequently a simplified "flattened-out" otolith-membrane. The mistake arising out of this is very small as regards the utricule otolith-membrane, as this membrane almost answers to a level plane. It is different with the saccule otolith-membrane of which the greater distal part is almost entirely level as well; the proximal part however is bent fairly strongly to the lateral side.

As is known the otolith-membranes have more or less the form of an ellipse, of which the long axis runs from proximal to distal.

The beginning and the end of this long axis can be determined in our series, by examining the section in which the said otolith-membrane comes first, and that in which it comes last.

In order to determine the otolith-plane, this line in itself does not suffice, other data must still be got from the otolith-membrane. For this purpose we choose a section lying halfway between the two extreme points of the long axis. In such a section the otolith-membrane shows itself as a line; (Pl. 7 representing part of the section in

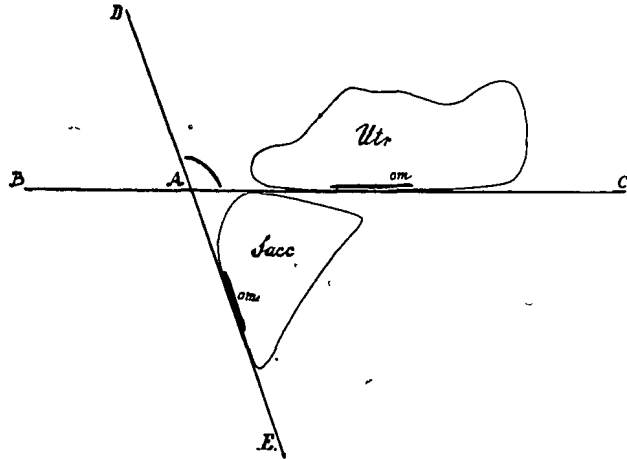

Pl. 7. Utricle and Sacculus from Pl. 6, by greater enlargement, o. m. otolithmembrane.

Pl. 6, by greater enlargement); a line however *not* cutting the long axis (middle-line). For the otolith-plane we take a plane brought through the long axis, running parallel to the line last mentioned.

For the construction of an otolith-plane we thus must know the projections of four points, taken from the otolith-membrane: first the projections of the extremes of the long axis; secondly the projections of two points of the middle-line. The execution of this construction thus depends on constructing a plane through a given line (the long axis) running parallel to another line (the middle-line) which two lines do not intersect. From the four planes (left and right utricle and sacculus otolith-planes) thus obtained, the angles which they form between them, are similarly determined, as has been described for the planes of the semicircular canals; the same planes of projection serve here.

§ 3. The information required in § 1 can be got not only by means of descriptive geometry, but also by another mathematical method.

If of each of two given planes three points are known by their coordinates, with regard to three planes, running perpendicularly, we are able to determine the angle between the two given planes, with the aid of analytic geometry.

Prof. ORNSTEIN, who has pointed out to us this possibility was kind enough to give us some formulas, with the help of which we were able to calculate the angles required between the planes of the semicircular canals and those of the otoliths.

We once more want to render thanks to Prof. ORNSTEIN, very much appreciating the trouble he took in introducing this matter to us.

This method had the great advantage for us, that the results we first obtained by means of descriptive geometry, could be compared with the results got from the formulas. Through this we disposed of a welcome means for controlling the accuracy of our drawings. It lies beyond our reach to enter into details on the derivation of the formulas used here. Suffice it to represent the method in short:

Formula for the calculation of the angle of two planes.

Let the coordinates of the three points in the first plane be

$$\begin{aligned} x_1, y_1, z_1 & \text{ 1 point.} \\ x_2, y_2, z_2 & \text{ 2 point.} \\ x_3, y_3, z_3 & \text{ 3 point.} \end{aligned}$$

Secondly calculate

$$\begin{aligned} y_1(z_2 - z_3) + z_1(y_3 - y_2) + (y_2 z_3 - z_2 y_3) &= A_1 \\ z_1(x_2 - x_3) + x_1(z_3 - z_2) + (z_2 x_3 - x_2 z_3) &= A_2 \\ x_1(y_2 - y_3) + y_1(x_3 - x_2) + (x_2 y_3 - y_2 x_3) &= A_3. \end{aligned}$$

Let the coordinates of the three points in the second plane be

$$\begin{aligned} x_1', y_1', z_1' & \text{ 1st point.} \\ x_2', y_2', z_2' & \text{ 2^d point.} \\ x_3', y_3', z_3' & \text{ 3^d point.} \end{aligned}$$

Thirdly calculate

$$\begin{aligned} y_1'(z_2' - z_3') + z_1'(y_3' - y_2') + (y_2' z_3' - z_2' y_3') &= A_1' \\ z_1'(x_2' - x_3') + x_1'(z_3' - z_2') + (z_2' x_3' - x_2' z_3') &= A_2' \\ x_1'(y_2' - y_3') + y_1'(x_3' - x_2') + (x_2' y_3' - y_2' x_3') &= A_3'. \end{aligned}$$

So, when Q is the angle of the planes

$$\cos. Q = \frac{A_1 A_1' + A_2 A_2' + A_3 A_3'}{\sqrt{(A_1^2 + A_2^2 + A_3^2)(A_1'^2 + A_2'^2 + A_3'^2)}} \quad (1)$$

The coordinates of the points on which these calculations are founded, must be taken from the data given in § 2, as here also we can use the same planes of projection as interperpendicular planes. (Page 54). For the four otoliths-planes and the six planes of the semicircular canals, the magnitudes A , A' , A'' etc. can be determined; by inserting these values to formula (1), we get the size of the angle Q , Q' , Q'' etc. being what we wished to know.

§ 4. As has been stated the material investigated consisted of

Size of the angle between			Series I		Series II		Series III		
			drawn	calculated	drawn	calculated	drawn	calculated	
1) <i>PPCL</i>	<i>PPCR</i>	α	96 $\frac{1}{2}$ °	96°	102°	103°36'	99°	97°25'	
2) <i>PSCL</i>	<i>PSCR</i>	β	78	77.54'	81	81.31'	88	86.50'	
3) <i>PECL</i>	<i>PECR</i>	γ	176	176.3'	174	173.33'	171 $\frac{1}{2}$	170.43'	
	<i>PSCR</i>	<i>IR</i>	95	95.48'	91	90.44'	92	91.35'	
	<i>PSCL</i>	<i>IL</i>	95	95.35'	95	96.30'	94 $\frac{1}{2}$	94.54'	
	<i>PPCR</i>	<i>IIR</i>	92 $\frac{1}{2}$	91.10'	95 $\frac{1}{2}$	97.4'	81	80.44'	
	<i>PPCL</i>	<i>III</i>	93 $\frac{1}{2}$	93.56'	91	91.7'	87 $\frac{1}{2}$	89.23'	
	<i>PPCR</i>	<i>IIIR</i>	93	94.23'	87	87.2'	88	89.14'	
	<i>PPCL</i>	<i>IIIL</i>	94	93.56'	87	87.47'	87	86.36'	
1) Mediumplane	<i>PPC</i>		48 $\frac{1}{4}$	48	51	51.48'	49 $\frac{1}{2}$	48.42'	
2) "	<i>PSC</i>		39	38.57'	40 $\frac{1}{2}$	40.45'	44	43.25'	
3) "	<i>PEC</i>		88	88.2'	87	86.46'	85.45	85.21'	
4) Craniumbase-line	Line of int. <i>PPC</i>		86		89		88		
5) "	" <i>PSC</i>		78		82		85 $\frac{1}{2}$		
6) "	" <i>PEC</i>		15 $\frac{1}{2}$		8)		1		
	<i>SL</i>	<i>UL</i>	<i>SUL</i>	107	107.18'	102	97.24'	98	104.51'
	<i>SR</i>	<i>UR</i>	<i>SUR</i>	103	103.14'	99	96.33'	100	96.50'
7) <i>SL</i>	<i>SR</i>	<i>SS</i>	46 $\frac{1}{2}$	47.9'	54	53.31'	63	63.56'	
3) <i>UR</i>	<i>UL</i>	<i>UU</i>	174	174.56'	173	166.17'	176	172.21'	
7) Mediumplane	<i>S</i>		23 $\frac{1}{4}$	23.34'	27	26.45'	31 $\frac{1}{2}$	31.58'	
3) "	<i>U</i>		87	87.28'	86 $\frac{1}{2}$	83.8'	88	86.11'	
5) Craniumbase-line	Line of int. <i>SS</i>		35		44		68 $\frac{1}{2}$		
4) "	" <i>UU</i>		39		31		63		

1) This angle is open to the back.

2) " " " " " " front.

3) " " " " " " top.

4) " " " " " " back, it is measured above the craniumbase-line.

5) " " " " " " front, " " " " " " " " " "

6) " " " " " " back, " " " " " " " " " "

7) " " " " " " front and downward.

8) The line of intersection of the two horizontal semicircular canals does not come in the medium-plane in this preparation; therefore the value cannot be given here.

three series. For each series the data required were first determined by way of descriptive, then by way of analytic geometry. The results thus obtained, were collected in a table (p. 59).

With the manipulation of the 3rd series, Mr. H. OORT (Med. Cand.) gave us his greatly appreciated help; the results, referring to this series have been determined by him.

In the detailed article on this subject, to be published elsewhere, we shall enter more deeply into the discussion, to which this table gives rise; some main points can be stated concisely:

1. It appears first of all, that the angles made by the planes of the semicircular canals, lying on one side, do not differ greatly from 90° .

The average¹⁾ value, calculated from the table, amounts to 94° for the angle between the superior plane and the exterior plane, to 90° for the posterior plane and the exterior plane and to $89\frac{1}{2}^\circ$ for the posterior plane and the superior plane.

2. The planes of the exterior semicircular canals on both sides, make between them an average angle of $173\frac{1}{2}^\circ$, their line of intersection forms a small angle (once $15\frac{1}{2}^\circ$, once 1°) with the cranium base-line (which is almost conform to the clivusline).

The planes of the two superior semicircular canals form between them an average angle of $82,5^\circ$, their line of intersection forms an angle of 82° , with the cranium base-line. The planes of the two posterior canals form between them an average angle of 99° ; their line of intersection forms an angle of 88° with the craniumbase-line.

3. The otoliths-membranes which are situated on one side form between them an average angle of 101° .

4. The planes of the two utricle-otoliths-membranes form between them an average angle of 173° ; their line of intersection forms with the craniumbase-line an angle of 44° .

The planes of the two sacculus-otoliths-membranes form between them an average angle of $54\frac{1}{2}^\circ$, their line of intersection forms with the craniumbase-line an angle of 49° .

¹⁾ To these average values calculated from a small number of observations, no great importance should be attached; therefore these numbers have not been mentioned in the table.

Botany. – “The influence of temperature on the growth of the roots of *Lepidium sativum*”. By Miss E. TALMA. (Communicated by Prof. F. A. F. C. WENT).

(Communicated in the meeting of April 28, 1916)

While I was engaged on an investigation of the influence of temperature on the growth of roots, I. LEITCH¹⁾ published “Some experiments on the influence of temperature on the rate of growth in *Pisum sativum*”. This paper reached me a short time ago, as did almost simultaneously an abstract of a paper by LEHENBAUER.²⁾

Although my investigations are not yet entirely completed, the above circumstances have induced me to publish a brief, preliminary account of the results obtained. SACHS mentions in his researches³⁾ that probably a simple relation exists between root growth and temperature, but nevertheless his investigations have produced no data on this point.

In connection with BLACKMAN's views⁴⁾ and the work on the influence of temperature on a number of vital processes, which has followed his publications, it was to be expected that an investigation according to a more modern method than that employed by SACHS, should yield some new results in the case of growth also.

The experimental object was *Lepidium sativum*; the seeds were soaked in water for one day, and then placed on vertical glass plates, covered with filter paper, in such a way that the rootlets grow down straight along the filter paper. On the third day the roots are placed in a thermostat; they have then attained a length of at least 8 m.m., so that it is possible to place a mark on an adult portion of the root. In the thermostat the temperature can be kept constant to within 0.3–0.4°, should the experiments last longer than 3 hours.

In order to avoid curvature of the roots, great care must be taken to provide fresh air and sufficient moisture, especially at higher temperatures.

Experiments in which the germination process also took place at a constant temperature, could not be made on account of the inadequate arrangements of the laboratory; perhaps they may yet be possible in the near future. Germination therefore took place at

1) Annals of Botany. January 1916. Vol. XXX. N^o. CXVII. p. 25.

2) Bot. Centrallblatt, Bd 129. N^o. 25. p. 662.

3) Pringsheim's Jahrbücher f. wiss. Botanik. Bd. 2. 1860 p. 338.

4) Annals of Botany. 1905, vol. XIX p. 281.

TABLE I.

Number of seedlings	Temperature during 3½ hours	Growth in m.m. expressed as mean
38	0°	0.1
88	10	1.46
44	15.7	2.31
96	20	3.2
29	22.7	3.53
26	23	3.73
54	25	4.15
60	26	4.25
140	27	4.76
50	28	4.82
20	29	4.45
67	30	4.27
72	32.5	3.61
44	35	2.45
21	39.6	0.98
49	40	0.86

TABLE II.

Number of seedlings	Temperature during 7 hours	Growth in m.m.	2 × value of growth in 3½ hours
59	20°	6.16	6.4
116	27	8.8	9.52
58	28	7.35	9.64
20	29	8.45	8.9
25	30	7.5	8.54
37	32.5	5.4	7.22
27	35	2.65	4.9
34	40	0.941	1.72

widely oscillating temperatures; the roots were of unequal length, but in the experiments made hitherto the rate of growth was found to be independent of the length, at least when the latter was between 13 and 25 m.m. In experiments which last for more than 7 or less than $3\frac{1}{2}$ hours it is not impossible, that the initial length may have some effect on growth.

The rate of growth was determined macroscopically at temperatures between 0° and 40° during $3\frac{1}{2}$ and 7 hours and the results have been represented by tables and curves.

In table I successive columns indicate: 1. the number of seedlings in the experiment, 2. the temperature at which the experiment was carried out during $3\frac{1}{2}$ hours, 3. the growth in m.m. expressed as the mean, calculated in the usual manner.

The same data, shown in table I for $3\frac{1}{2}$ hours, are shown in table II for observations of 7 hours' duration. In addition the latter table has a fourth column, giving the calculated growth increment for 7 hours in the thermostat, if the rate of growth in the second period of $3\frac{1}{2}$ hours had been the same as in the first period of $3\frac{1}{2}$ hours.

The tables show that for experiments of $3\frac{1}{2}$ hours' duration the optimum lies at 28° . Whilst at temperatures below 27° the rate of growth gradually diminishes, irregularities occur at higher temperatures; extrapolation according to BLACKMAN does not seem possible.

Furthermore growth was observed at 0° ; there is no sudden cessation of growth; SACHS' representation of the minimum is therefore not correct. Probably something of this kind also applies to the maximum.

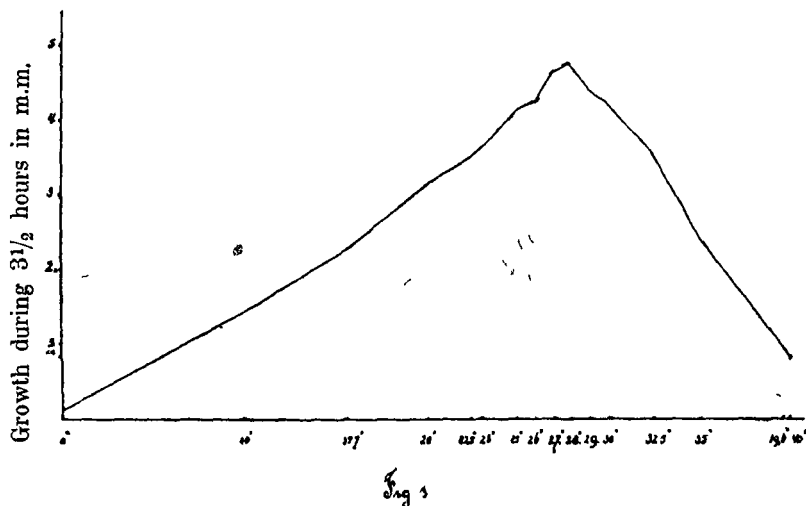

Experiments at temperatures above 40° have not yet been made; it is probable that the value recorded for the rate of growth at 40° must already in part be attributed to the time which elapses between the determination of the initial length and the establishment of thermal equilibrium. Such observations above 40° will have to be made microscopically.

The results become still clearer by graphic representation in figs. 1 and 2. Here the abscissae indicate temperature, the ordinates the growth in m.m. In fig. 2 the curves from 27° onwards have been drawn on a larger scale, in order to make more evident the falling off of the rate of growth at higher temperatures, with increased duration of the experiment. The dotted line in fig. 2 records the

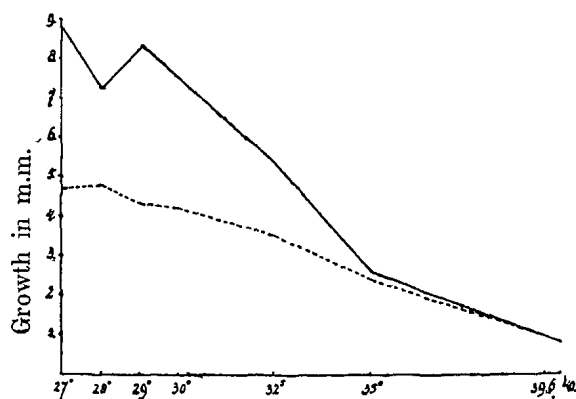

Fig 2

TABLE III.

Temperature coefficients
for experiments
of 3½ hours

$$\frac{10^{\circ}}{0^{\circ}} = \pm 14$$

$$\frac{20^{\circ}}{10^{\circ}} = 2.2$$

$$\frac{26^{\circ}}{16^{\circ}} = 1.9$$

$$\frac{30^{\circ}}{20^{\circ}} = 1.3$$

$$\frac{35^{\circ}}{25^{\circ}} = 0.6$$

$$\frac{40^{\circ}}{30^{\circ}} = 0.21$$

growth in experiments lasting $3\frac{1}{2}$ hours; that drawn in full represents the growth in experiments of 7 hours. At and above 35° practically no growth takes place in the second period of $3\frac{1}{2}$ hours.

In conclusion the temperature coefficient has been calculated for intervals of 10° , relating to the observations during $3\frac{1}{2}$ hours.

We see, as has been indicated by COHEN STUART¹⁾ in his study of the subject, that VAN 'T HOFF's rule at most applies only over a small range; for the rest the coefficient falls with rise of temperature.

Utrecht, April 1916. Botanical Laboratory of the University.

Astronomy. — "*Determination of the constant of Precession and of the Systematic Proper motions of the stars, by the comparison of KÜSTNER's catalogue of 10663 stars with some zone-catalogues of the "Astronomische Gesellschaft"*". By C. DE JONG. (Communicated by Prof. E. F. VAN DE SANDE BAKHUYZEN).

(Communicated in the meeting of April 28, 1916).

1. Introduction.

The research, the results of which will here be given in an abbreviated form, originated in a subject for a prize essay which the University of Leiden gave out in 1914, that of determining the constant of precession and the systematic proper motions by a comparison of KÜSTNER's Catalogue of 10663 stars (Veröff. Bonn N^o. 10) with Zone-Catalogues of the "Astronomische Gesellschaft". The essay which I wrote, was awarded the prize by the Faculty of Natural Science in Leiden. Prof. E. F. VAN DE SANDE BAKHUYZEN then suggested to me to continue the research and make it into a complete whole by using all the available material, i.e. that for which the difference of epoch with KÜSTNER is not too small, and reducing it in a strictly systematic manner; this suggestion I followed willingly.

It is indeed of importance to derive the constant of Precession and the elements of the motion of the sun from the above mentioned material; it is the only combination of catalogues with, at all considerable difference of epoch in which, for both, the magnitude-error has been eliminated or determined with sufficient accuracy. For the zone-catalogues of the Astr. Ges. two determinations of the error in

¹⁾ C. P. COHEN STUART. A study of temperature coefficients and VAN 'T HOFF's rule. Proc. Kon. Akad. van Wet. Amsterdam, 1912.

question have been made by AUWERS, while researches also have been carried out at Leiden for the zone observed there. KÜSTNER, by placing gauze screens in front of the objective of the telescope, has eliminated the error in a very satisfactory manner. Moreover I had the privilege of discussing various difficulties with Prof. BAKHUYZEN himself, and of experiencing his continued interest in my work, for which I take this opportunity of thanking him very sincerely.

2. *Material used.*

With KÜSTNER's Catalogue (Aequin 1900) the following zone-catalogues of the Astr. Ges. (Aequin 1875) were compared in R.A. and Decl.:

1. Berlin A, Decl. $+ 15^\circ$ to $+ 20^\circ$;
2. Berlin B, „ $+ 20^\circ$ „ $+ 25^\circ$;
3. Leipzig I, „ $+ 10^\circ$ „ $+ 15^\circ$;
4. Leiden, „ $+ 30^\circ$ „ $+ 35^\circ$.¹⁾

The positions of the latter were reduced from 1875 to 1900 by means of the mean of the precession-values given in the two catalogues (constants according to PETERS-STRUVE). KÜSTNER's catalogue (Kü) proved to have the following numbers of stars in common with the zone-catalogues, with the epochs as given:

	<i>Number of stars</i>	<i>Epochs</i>	<i>Difference of epochs</i>
Be A	768	1870,5—1896,5	26,0 years
Be B	812	1881,0—1897,0	16,0 „
Lei I	711	1874,3—1896,45	22,15 „
Leiden	926	1873,8—1898,0	24,2 „

Catalogue Berlin BECKER (Be B) has only a small difference of epoch with KÜSTNER, but its great accuracy compensates this to a great extent.

3. *Immediate results of the comparison.*

To the differences $\Delta\alpha$ and $\Delta\delta$ Kü—A.G. found directly by the comparison various corrections had first to be applied, in order to make them suitable for further discussion. These corrections are the following:

1. *The reductions of the A. G. catalogues to the system of AUWERS's fundamental Catalogue of the A. G.* These were assumed according

¹⁾ The comparison with Leiden in R.A. had been made before at the Leiden Observatory; I was able to use the results.

to AUWERS's tables occurring in A.N. 3844, with the exception of the A.R. Leiden, for which the magnitude equation lately deduced by Dr. E. F. v. d. S. B. was adopted; ¹⁾

2. the reduction of Kü to the Fundamental system of AUWERS, only needed for the Decl. and applied according to the table in the introduction to KÜSTNER's Catalogue, p. 35;

3. the variation during the difference of epoch of the reductions $\Delta\alpha_z$ and $\Delta\delta_z$ of AUWERS' old Fund. Cat. to the new Cat. of the Berliner Jahrbuch (A.N. 3927);

4. the variation during the difference of epoch of the corresponding reductions $\Delta\alpha_s$ and $\Delta\delta_s$.

Reductions 1 and 2 were introduced everywhere completely, 3 was not immediately applied to the results of the comparison, while of 4 only parts were added to the coordinate-differences found. Besides 1 and 2 the following corrections were applied on account of 4:

a. to the differences Kü—A.G. in R.A.:

Be A	+ 0.020	instead of	+ 0.0205
Be B	+ 0.012	„ „	+ 0.0128
Lei I	+ 0.018	„ „	+ 0.0185
Leiden	0.000	„ „	+ 0.0202

b. to the differences Kü—A.G. in Decl.

Be A	— 0.25	instead of	— 0.25
Be B	— 0.14	„ „	— 0.11
Lei I	0.00	„ „	— 0.22
Leiden	0.00	„ „	— 0.21

The remaining parts of 4 were brought into account after the solution of the equations. For Be A use is also made of the "Reduction der aus den Zonenbeobachtungen abgeleiteten Deklinationen auf A. G. C." occurring on p. 131 of the Introduction to this Catalogue. The corrections 3 are solved separately.

From the differences in α and δ thus corrected various means were formed. In order to be able to test the influence of the magnitude of the stars used — either on account of remaining magnitude-errors or of cosmic influences — upon the constants derived from them, groups according to magnitude were formed, and that for each hour of the right ascension separately. In this it proved preferable, on account of the limited number of stars, to confine ourselves to two groups according to magnitude. The division was made according to the magnitudes given by Kü; the magnitude 8.50 was taken as the limit. Thus

¹⁾ Annalen der Sternwarte in Leiden, 9, 386.

1. a "bright" group, called group B.
2. a "faint" group, called group F.

were formed.

Further the ever difficult question of the exclusion of stars had now to be weighed. NEWCOMB, in his deduction of the precessional constant from the BRADLEY stars, excluded all stars with proper motion above certain limits depending upon the magnitude and entirely ignored these. In this way he loses more than $\frac{1}{3}$ of the whole number of stars. In the reduction of the material of this paper it did not seem advisable to confine oneself to this method. Besides the deduction of the results in NEWCOMB's manner I made a second calculation practically *without exclusion*, that is, only some extremely large differences were excluded. The work was therefore done in two ways:

1. all stars (with the exception of a few very large differences) are used; solution A;
 2. stars with P. M. above certain limits are excluded: solution E.
- There were, therefore, four solutions made: BA, BE, FA, FE.

Excluded unconditionally were: (see 1):

- in Be A* all stars with $\Delta\alpha > 0.5$ or $\Delta\delta > 7.5$;
- in Be B* ,, ,, ,, $\Delta\alpha > 0.35$,, $\Delta\delta > 5.0$;
- in Lei I* ,, ,, ,, $\Delta\alpha > 0.4$,, $\Delta\delta > 6.0$;
- in Leiden* ,, ,, ,, $\Delta\alpha > 0.5$,, $\Delta\delta > 7.5$.

These are altogether only about twenty in number. Moreover, in all four catalogues the double stars are unconditionally excluded, being respectively 18, 31, 15 and 37 in number. It is unnecessary to point out that this last exclusion is certainly justified. As regards the unconditional exclusion on account of too large differences it may be further remarked that in this the two coordinates have also exercised an influence upon each other, as stars with too great a $\Delta\alpha$ are also excluded in δ , and vice versa. In this way the A groups were formed.

For the E groups the following values are accepted as the greatest
Limits for the E-groups.

Catalogue	4th magnitude	5th—7th magnitude	8th magnitude	9th magnitude
Be A	0.20 3.0	0.15 2.2	0.12 1.8	0.10 1.5
Be B	0.12 1.5	0.10 1.5	0.08 1.5	0.06 1.5
Lei I	0.20 3.0	0.15 3.0	0.12 3.0	0.10 3.0
Leiden	0.20 2.5	0.20 2.5	0.20 2.5	0.20 2.5

allowable proper motion during the interval between the epochs.

In this the two coordinates have had no influence upon each other; a star which had to be omitted in the computation of the E-mean of the $\Delta\alpha$ on account of too large a value was *not* excluded from the $\Delta\delta$ on that account. In this way in forming the Egroups for each catalogue about 100 stars were excluded.

As in the discussion of the results from the comparison between Kü. and Be A a great difference became apparent between the values of the precession-constant m derived from the bright and from the faint groups (that is from BA and BE on the one hand and from FA and FE on the other) it was thought desirable to institute a further research into this point. For this purpose the fainter group in Berlin A was split into two, one between magnitude 8.50 and 9.15, the other below 9.15. For both groups, called F_1 and F_2 solutions A and E were made. In the following table these groups are found as F_1A , F_1E , F_2A and F_2E .

As already said, in the formation of the Egroups the two coordinates had no influence upon each other. The opposite point of view might also be defended, while it may be said in favour of the method here followed, that it is illogical to exclude stars from one coordinate because of a large accidental error in the other. In any case it seemed desirable to see what would be the influence of the exclusion, also according to the other coordinate. This was done for the R.A. of Berlin A; for this catalogue E' groups were formed for which the same exclusion-limits were used as in the Egroups, but in which exclusion also took place on account of the other coordinate. The groups formed on this principle are called BE' and FE'.

In the following table I have collected the hourly means formed after the different principles; in this table 0^h means the group from 23^h30^m to 0^h30^m , etc. while under n the number of stars used is given. The unit is in the R.A. $0^s.01$, in the Decl. $0''.1$.

MEAN DIFFERENCES KU—A.G.

1) Berlin A, Right-Ascensions.

Hour	BA		BE		FA		FE	
	$\Delta\alpha$	n	$\Delta\alpha$	n	$\Delta\alpha$	n	$\Delta\alpha$	n
0	+ 9.15	15	+3.72	11	-1.30	12	+2.42	9
1	+10.00	10	+0.92	4	+4.42	14	-0.19	11
2	+ 5.82	12	+6.07	10	-0.01	14	+0.21	10
3	+ 2.22	9	+2.22	9	+2.46	10	+0.83	9
4	+10.56	14	+6.16	11	+2.85	10	- 0.58	9
5	+ 2.51	15	+2.07	12	+2.69	15	+2.69	15
6	- 1.01	23	-0.04	22	-0.25	23	+0.72	19
7	+ 2.45	11	+1.42	10	+2.51	19	+0.55	17
8	- 3.58	15	-1.67	14	-1.55	24	-0.73	21
9	- 1.36	17	-0.44	15	+0.31	18	-1.79	15
10	- 3.89	12	-3.89	12	-5.66	21	-2.44	17
11	- 5.70	12	-2.82	10	-7.80	20	-6.19	16
12	-12.02	8	-4.68	5	-6.83	17	-4.24	14
13	- 5.94	11	-5.94	11	-6.03	19	-4.52	17
14	-13.89	13	-8.22	8	-4.73	18	- 6.42	16
15	- 7.00	8	-7.00	8	-4.13	23	-3.06	17
16	- 4.16	11	-2.37	10	-5.43	22	-4.22	20
17	- 4.88	14	-1.92	12	-0.81	22	-1.28	20
18	- 0.26	13	-0.26	13	0.96	19	-1.73	18
19	- 0.82	10	+0.63	9	-1.34	19	-1.34	19
20	- 2.08	17	-2.08	17	+0.54	21	+0.54	21
21	+ 1.72	13	+0.66	12	+2.65	22	+1.24	20
22	+ 4.62	10	+4.62	10	+0.96	20	-0.22	19
23	+ 5.29	10	-0.04	7	-0.18	17	+0.67	11

Hour	F_1A		F_1E		F_2A		F_2E	
	$\Delta\alpha$	n	$\Delta\alpha$	n	$\Delta\alpha$	n	$\Delta\alpha$	n
0	-2.78	6	+2.62	4	+0.18	6	+2.26	5
1	+5.57	6	-2.34	5	+3.55	8	+1.60	6
2	-1.49	7	+0.13	6	+1.28	8	+0.32	4
3	+4.07	6	+1.46	5	+0.05	4	+0.05	4
4	+3.61	7	-1.40	6	+1.07	3	+1.07	3
5	+2.22	10	+2.22	10	+3.64	5	+3.64	5
6	+1.51	9	+0.79	7	-1.38	14	+0.68	12
7	+1.23	10	+1.23	10	+3.93	9	-0.43	7
8	-2.01	11	-2.01	11	-1.16	13	+0.68	10
9	-0.21	8	-3.70	6	+0.73	10	-0.52	9
10	-5.88	8	-2.62	5	-5.14	14	-2.37	12
11	-6.27	7	-4.98	5	-8.64	13	-6.74	11
12	-7.69	11	-3.49	8	-5.23	6	-5.23	6
13	-5.27	13	-4.13	12	-7.37	6	-5.04	5
14	-6.77	6	-6.77	6	-3.71	12	-6.21	10
15	-4.67	6	-2.36	5	-3.94	17	-3.35	12
16	-6.81	8	-5.66	7	-4.71	14	-3.53	13
17	-3.07	10	-1.53	9	+1.07	12	1.06	11
18	-3.14	10	-3.14	10	+1.46	9	+0.04	8
19	-0.07	12	-0.07	12	-3.53	7	-3.53	7
20	+0.38	12	+0.38	12	+0.76	9	+0.73	9
21	+3.08	13	+2.12	12	+2.32	9	+2.26	8
22	-1.31	11	-1.31	11	+3.72	9	+1.29	8
23	-2.82	8	+0.67	3	+2.18	9	+0.68	8

Hour	<i>BE</i>		<i>FE</i>	
	Δa	<i>n</i>	Δa	<i>n</i>
0	+3.72	11	+0.98	6
1	+0.92	4	+0.20	9
2	+5.95	9	+0.87	11
3	+2.22	9	+1.83	8
4	+5.97	10	-0.59	8
5	+1.22	11	+2.34	12
6	-0.04	22	+0.79	18
7	+1.42	10	+0.55	17
8	-1.67	14	-1.13	19
9	-0.44	15	-1.81	12
10	-3.89	12	-2.44	17
11	-2.82	10	-6.38	14
12	-4.68	5	-3.14	11
13	-5.94	11	-4.52	17
14	-8.22	8	-5.60	13
15	-7.00	8	-2.61	15
16	-1.63	9	-4.24	17
17	-1.92	12	-0.77	19
18	-0.26	13	-1.73	18
19	+0.63	9	-1.07	17
20	-2.21	16	+0.83	19
21	+0.47	11	+2.18	18
22	+4.62	10	-0.22	19
23	+1.55	6	+0.67	11

2) Berlin A, Declination.

Hour	BA		BE		FA		FE	
	$\Delta\delta$	n	$\Delta\delta$	n	$\Delta\delta$	n	$\Delta\delta$	n
0	-0.99	15	-0.99	15	+0.46	12	-1.64	8
1	+0.92	10	-0.97	9	-7.16	14	-6.05	10
2	-5.78	12	-5.78	12	-6.60	14	-7.08	12
3	-4.31	9	-4.31	9	-12.19	10	-7.68	8
4	-6.39	14	-4.98	12	-6.62	10	-0.79	8
5	-7.97	15	-4.92	14	-13.43	15	-10.04	12
6	-5.32	23	-5.32	23	-7.94	23	-5.51	21
7	-6.08	11	-3.11	10	-4.84	19	-5.72	17
8	-5.27	15	-2.88	14	-10.44	23	-6.20	19
9	-6.37	17	-4.39	16	-6.41	18	-5.58	15
10	-7.53	12	-7.53	12	-5.43	21	-6.66	20
11	-0.45	12	-0.45	12	-8.23	20	-5.21	17
12	-2.59	8	-2.59	8	-6.68	17	-4.74	13
13	-3.25	11	-3.25	11	-4.49	19	-3.35	18
14	+0.91	13	-0.60	10	-6.53	18	-5.53	13
15	-9.55	8	-4.64	7	-4.26	23	-4.92	20
16	-3.59	11	-8.01	10	-7.29	22	-6.18	19
17	+0.69	14	+0.69	14	-3.71	22	-2.74	21
18	+0.19	13	+0.19	13	-8.81	19	-8.81	19
19	-6.55	12	-6.55	12	-7.34	19	-5.30	17
20	-2.21	17	-0.25	16	-3.28	21	-3.46	19
21	-1.63	13	-3.21	12	-5.47	23	-4.48	20
22	-5.13	10	-5.13	10	-3.99	20	-3.99	20
23	-6.73	10	-2.35	8	-8.71	17	-4.11	13

3) Berlin B, Right-Ascension

Hour	BA		BE		FA		FE	
	$\Delta\alpha$	n	$\Delta\alpha$	n	$\Delta\alpha$	n	$\Delta\alpha$	n
0	+2.70	8	+1.10	7	+0.12	20	-0.17	18
1	+2.57	15	+1.16	12	+2.27	19	+0.01	16
2	+2.70	7	-1.94	5	-1.30	20	-0.73	15
3	+2.37	13	+0.27	12	-1.14	19	-1.53	17
4	+3.35	23	+2.46	20	+1.42	13	+0.53	12
5	+3.53	15	+1.72	13	+2.96	15	+2.65	13
6	+0.10	21	+0.91	20	-2.29	19	-0.08	13
7	+0.00	19	+0.00	19	-1.08	18	-0.72	17
8	+1.29	15	-0.67	14	-0.81	15	-0.68	13
9	-3.01	12	-0.58	10	-1.35	22	-0.41	21
10	-2.93	12	-1.84	9	-2.06	16	-1.59	15
11	-3.27	7	-3.27	7	-3.29	21	-1.97	16
12	-3.22	9	-3.22	9	-4.62	24	-1.32	15
13	-4.41	12	-4.41	12	-0.87	19	-0.15	13
14	-2.70	11	-2.70	11	-4.72	20	-3.48	17
15	-2.15	8	-2.15	8	-1.42	18	-1.77	17
16	-0.79	8	0.79	8	+0.42	20	+0.69	15
17	-1.37	12	-1.74	10	-1.74	30	-1.72	28
18	3.18	20	-2.64	19	-3.07	16	-3.22	11
19	-0.17	24	-0.19	20	-1.78	16	-1.30	15
20	+1.79	17	+1.79	17	-0.03	12	-0.03	12
21	+1.27	15	+1.12	13	-0.31	17	+0.95	15
22	+3.72	16	+0.68	14	-1.09	17	-0.93	15
23	+1.21	12	+1.21	12	-0.11	17	-0.13	13

4) Berlin B, Declination.

Hour	BA		BE		FA		FE	
	$\Delta\delta$	n	$\Delta\delta$	n	$\Delta\delta$	n	$\Delta\delta$	n
0	-4.75	8	-1.15	6	-5.05	22	-4.2	19
1	-6.05	15	-6.05	15	-10.0	19	-8.0	16
2	-6.75	7	-6.75	7	-6.3	19	-7.7	15
3	-5.65	13	-4.05	12	-4.1	19	-3.5	18
4	-8.35	23	-5.95	19	-8.7	13	-7.7	12
5	-8.45	15	-8.45	15	-10.0	16	-7.1	13
6	-4.75	21	-4.75	21	-9.8	19	-7.0	17
7	-8.55	19	-5.55	15	-8.8	18	-7.7	16
8	-5.35	15	-5.35	15	-6.6	15	-5.3	14
9	-7.35	12	-2.55	9	-2.9	22	-3.9	21
10	-5.85	12	-2.45	10	-5.3	16	-4.5	15
11	-8.65	7	-4.95	6	-9.2	20	-6.8	17
12	-3.45	10	-3.45	10	-9.4	24	-5.6	19
13	-6.35	12	-5.25	11	-11.4	19	-6.3	13
14	-6.25	11	-6.25	11	-4.9	20	-4.3	19
15	-5.65	8	-5.65	8	-5.7	18	-5.7	18
16	-6.9	8	-3.25	7	-6.4	20	-5.2	18
17	-4.4	12	-0.05	10	-2.3	30	-1.3	29
18	-4.85	20	-2.95	17	-7.1	16	-6.4	15
19	-4.25	24	-3.25	20	-5.3	16	-5.3	16
20	-0.15	17	-0.15	17	-4.3	12	-2.1	11
21	-2.05	15	-0.65	14	-3.9	17	-3.9	17
22	-4.05	16	-4.05	16	-4.9	17	-3.9	16
23	-1.55	12	-3.15	11	-9.5	17	-8.65	16

5) Leipzig I, Right-Ascension.

Hour	BA		BE		FA		FE	
	$\Delta\alpha$	n	$\Delta\alpha$	n	$\Delta\alpha$	n	$\Delta\alpha$	n
0	- 1.60	15	-1.58	13	-1.73	13	-0.18	11
1	+ 0.37	7	+0.37	7	-1.25	22	+0.25	18
2	+10.70	7	+7.84	5	+1.80	15	-0.19	12
3	+ 3.38	10	-1.20	8	-1.88	12	-0.82	11
4	+ 8.28	13	+3.77	10	+0.22	16	-0.28	12
5	- 0.06	9	-0.06	9	+5.98	23	+3.44	20
6	- 0.26	17	+2.24	15	+1.06	25	+0.89	23
7	- 1.62	11	1.62	11	-1.68	15	-1.68	15
8	- 7.97	15	-6.06	13	-2.58	16	-1.92	13
9	- 6.02	13	-3.56	11	-0.32	12	-3.94	10
10	- 9.00	10	-6.15	8	-3.32	11	-3.32	11
11	- 6.33	9	4.11	8	-7.28	16	-5.35	14
12	-11.04	5	-9.95	4	-5.94	16	-4.99	15
13	- 4.85	11	-6.34	8	-1.54	15	-2.32	14
14	- 4.06	10	-4.32	8	-4.06	20	-4.21	19
15	- 0.18	8	-0.18	8	-4.24	13	-3.05	10
16	- 4.90	10	-4.90	10	-5.40	20	-3.86	18
17	- 3.33	14	-3.33	14	-6.00	14	-3.56	12
18	- 2.92	14	- 2.92	14	-4.33	15	-2.90	14
19	+ 2.16	15	+1.46	14	- 2.40	26	-1.69	23
20	+ 1.08	13	+1.08	13	-0.10	22	+0.10	20
21	+ 2.90	22	+1.80	20	+4.32	17	+2.88	15
22	+ 2.45	12	+4.06	11	-0.73	23	-0.02	22
23	- 1.13	7	+0.77	6	-1.20	19	-0.57	15

6) Leipzig I, Declination

Hour	BA		BE		FA		FE	
	$\Delta\delta$	n	$\Delta\delta$	n	$\Delta\delta$	n	$\Delta\delta$	n
0	+1.47	15	+1.47	15	+ 4.31	13	+4.31	13
1	+9.29	7	+5.17	6	+ 2.36	22	+ 2.36	22
2	+5.71	7	+5.71	7	+ 0.07	15	+ 0 07	15
3	+1.90	10	+1.90	10	- 6.75	12	- 6.75	12
4	-5.23	13	-5.23	13	- 6 00	16	- 6.50	14
5	-1.89	9	-1 89	9	- 9.26	23	- 8.28	22
6	+1 94	17	-0.62	16	- 2 56	25	- 2.56	25
7	-2.82	11	-2.82	11	- 0.93	15	- 0.93	15
8	-5.67	15	-5.67	15	- 6.69	16	- 6.69	16
9	-7.38	13	-5.42	12	-10.00	12	-10.00	12
10	+2.40	10	+2.40	10	- 7.82	11	- 7.82	11
11	+2.11	9	+2.11	9	- 6.12	16	- 6.12	16
12	+2.00	5	+2.00	5	- 0.62	16	- 0.62	16
13	-4.64	11	+0.50	10	- 6.67	15	- 4.93	14
14	+0.20	10	+0.20	10	- 3.50	20	- 3.50	20
15	+3.75	8	-0.86	7	- 1.69	13	+ 1.00	12
16	+5.60	10	+5.60	10	- 4.35	20	- 2.95	19
17	-6.28	14	-6.28	14	- 6.57	14	- 3.69	13
18	+2.71	14	+2.71	14	- 0.93	15	- 0.93	15
19	+1.00	15	+1.00	15	- 2.73	26	- 1.52	25
20	+5.15	13	+5.15	13	- 1.77	22	- 1 77	22
21	+5.55	22	+4.29	21	+ 1.12	17	+ 1.12	17
22	+0.17	12	+0 17	12	+ 1 09	23	+ 1.09	23
23	-0.29	7	-0.29	7	- 2.74	19	- 2.74	19

7) Leiden, Right Ascension.

Hour	BA		BE		FA		FE	
	$\Delta\alpha$	n	$\Delta\alpha$	n	$\Delta\alpha$	n	$\Delta\alpha$	n
0	-3.71	12	-2.33	11	+2.91	21	+1.24	20
1	+4.34	18	+0.28	16	+1.29	19	+3.89	17
2	-7.00	16	-5.00	14	+0.95	16	+0.95	16
3	+1.04	14	+1.17	13	-5.14	23	-4.23	21
4	-3.48	10	-3.48	10	+1.89	18	-0.07	17
5	-0.48	15	-1.15	13	-0.08	24	-0.08	24
6	-1.08	18	-1.12	16	-0.10	17	-0.10	17
7	-2.06	19	-2.06	19	-1.97	22	-1.08	21
8	-2.65	18	-0.34	15	-2.41	24	-1.48	23
9	-6.35	14	-3.42	12	-3.38	25	-2.12	24
10	-7.11	16	-5.07	13	-3.90	23	-2.92	21
11	-11.21	16	-7.94	14	-6.91	22	-4.18	19
12	-12.15	17	-9.37	12	-8.98	18	-7.30	15
13	-6.26	8	-0.78	7	-5.36	31	-3.53	23
14	-0.30	5	-10.07	2	-12.26	34	-7.44	25
15	-12.60	11	-5.13	7	-10.63	27	-9.02	22
16	-9.27	12	-1.96	8	-6.14	28	-2.37	22
17	-3.51	11	-6.23	9	-3.70	25	-4.04	24
18	-2.22	14	-1.82	13	-2.30	23	-2.30	23
19	-0.14	22	-1.79	21	-0.36	17	-0.36	17
20	-3.08	24	-2.77	22	-0.60	19	-0.65	18
21	-2.21	13	-2.21	13	+4.69	20	+4.69	20
22	-0.27	9	-0.27	9	+1.97	20	+1.97	20
23	+0.14	13	-0.40	11	-2.79	17	-2.08	16

8) Leiden, Declination.

Hour	BA		BE		FA		FE	
	$\Delta\delta$	<i>n</i>	$\Delta\delta$	<i>n</i>	$\Delta\delta$	<i>n</i>	$\Delta\delta$	<i>n</i>
0	-2.50	12	-2.50	12	-2.74	21	+0.31	18
1	+0.17	18	-1.62	17	-2.32	17	-2.76	15
2	-3.56	17	-3.56	17	-0.88	16	-0.88	16
3	-10.92	14	-8.47	13	-6.12	23	-2.22	20
4	-9.75	10	-9.75	10	-9.95	18	-6.28	14
5	-13.51	15	-8.59	12	-5.82	24	-4.78	22
6	-6.34	18	-3.44	16	-5.80	17	-5.80	17
7	-5.37	19	-4.33	18	-2.73	22	-1.95	21
8	-9.55	18	-3.70	15	-2.54	24	-3.34	23
9	-5.53	14	-1.88	12	-1.98	25	-0.98	24
10	-6.06	17	-4.31	16	-6.85	23	-2.68	20
11	-4.28	16	-3.00	15	-2.29	22	-0.36	21
12	-2.24	17	-1.00	14	-4.22	18	+0.86	14
13	-8.00	8	-8.00	8	-5.58	32	-2.43	22
14	-6.57	7	-5.50	2	-0.15	34	-0.07	30
15	+4.82	11	+4.82	11	-2.33	27	-0.83	21
16	-6.86	11	+0.89	9	-0.75	28	-1.09	23
17	+0.90	10	+1.12	8	-4.12	26	-0.86	22
18	+3.36	14	+0.31	13	-1.26	23	-1.43	21
19	-1.27	22	+0.10	21	-2.44	17	-2.44	17
20	-4.75	24	-3.04	23	-1.03	19	-0.25	17
21	-0.41	11	-0.41	11	-0.10	20	+0.08	18
22	-6.28	9	-6.28	9	-1.55	20	-0.82	19
23	+0.14	14	-1.36	11	-3.67	18	-1.35	17

4. *Method of discussion the results. Solution of the equations.*

In order to render the determination of the constants as simple and as systematic as possible, and thereby to be able to conveniently make use of the results obtained in a previous research by Dr. E. F. v. D. SANDE BAKHUYZEN and myself concerning the influence exercised upon the determination of the constant of Precession and the systematic Proper-motions by the connection between the value of the parallax of the stars and their apparent distance from the galactic plane¹⁾, the hourly means were represented by formulae of the form:

$$\Delta a = a + b \sin \alpha + c \cos \alpha \quad (1)$$

$$\Delta \delta = a' + b' \sin \alpha + c' \cos \alpha \quad (2)$$

and the values of the coefficients were deduced from these equations.

The same weight is given to all hourly means everywhere, in spite of the sometimes considerably diverse number of stars upon which they are founded. By this means we gained the very material advantage that all the inequalities depending upon the sines or cosines of multiples of α become eliminated.

Moreover the centennial variations of the reductions Δa_z and $\Delta \delta_z$ of AUWERS'S Old Fund. Cat. to his new one were developed in formulae of the same form. These expressions, as being probably known with sufficient accuracy — which was doubted at first — were added to the corresponding terms of the formulae (1) and (2).

The following table contains the values of the coefficients of both formulae *per 100 years*; in this the centennial variations of the reductions Δa_z and $\Delta \delta_z$ have been taken, into account.

In order to facilitate the further calculations, instead of the coefficients b and c , the quantities $b \cos \delta$ and $c \cos \delta$ are given in the table. The results are all expressed in seconds of arc.

¹⁾ These Proceedings. 18, 683—695.

COEFFICIENTS OF THE FORMULAE FOR $\Delta\alpha$ AND $\Delta\delta$ PER CENTURY.

Catalogue	BA	BE	BE'	FA	FE	FE'	F ₁ A	F ₁ E	F ₂ A	F ₂ E
I) COEFFICIENT a										
Be A	-0''25	-0''27	-0''24	-0''62	-0''66	-0''55	-0''88	-0''77	-0''41	-0''54
Be B	+0.06	-0.45		-0.92	-0.58					
Lei I	0.93	-0.90		-1.15	-1.00					
Leiden	-1.14	-0.65		-0.39	+0.16					
II) COEFFICIENT $b \cos \delta$										
Be A	+1.33	+0.87	+0.79	+0.58	+0.41	+0.33				
Be B	+0.68	+0.40		+0.34	+0.36					
Lei I	+0.10	+0.09		+0.90	+0.32					
Leiden	+0.18	+0.22		+0.39	+0.22					
III) COEFFICIENT $c \cos \delta$										
Be A	+4.23	+2.38	+2.41	+2.13	+1.62	+1.59				
Be B	+2.80	+1.80		+1.37	+0.71					
Lei I	+3.66	+2.96		+1.73	+1.72					
Leiden	+2.19	+1.40		+2.56	+1.92					
IV) COEFFICIENT a'										
Be A	-1.52	-1.29		-2.55	-2.01					
Be B	-3.39	-2.49		-4.22	-3.44					
Lei I	-1.10	-1.20		-3.23	-3.03					
Leiden	-2.09	-1.54		-1.40	-0.78					
V) COEFFICIENT b'										
Be A	-0.68	-0.38		-0.67	-0.29					
Be B	-1.10	-1.05		-0.88	-0.77					
Lei I	-0.84	-0.82		-0.82	-1.09					
Leiden	-1.69	-1.27		-0.81	-0.67					
VI) COEFFICIENT c'										
Be A	+0.02	+0.03		+0.03	+0.11					
Be B	+0.67	+0.19		+0.21	-0.23					
Lei I	+0.84	+0.58		+1.22	+1.05					
Leiden	+0.18	-0.31		+0.06	0.12					

6

5. *Correction-terms.*

The following relations now apply ¹⁾:

$$\begin{aligned} a &= \Delta m - 0.04 X \sin \delta + 0.22 Y \sin \delta \\ b \cos \delta &= \Delta n \sin \delta + 0.93 \lambda - 0.04 Y \cos^2 \delta \\ c \cos \delta &= - (0.93 Y + 0.20 Y \cos^2 \delta - 0.04 X \cos^2 \delta) \\ a' &= -0.93 Z \cos \delta - 0.10 Z \cos^3 \delta - 0.21 X \cos \delta \sin^2 \delta - 0.03 Y \cos \delta \sin^2 \delta \\ b' &= 0.93 Y \sin \delta + 0.04 X \cos^2 \delta \sin \delta + 0.08 Z \cos^2 \delta \sin \delta \\ c' &= \Delta n + 0.93 X \sin \delta + 0.20 X \cos^2 \delta \sin \delta + 0.04 Y \cos^2 \delta \sin \delta + 0.43 Z \cos^2 \delta \sin \delta \end{aligned}$$

where Δm and Δn represent the corrections of the constants of precession m and n and X , Y , Z the components of the motion of the sun.

The following are considered as correction-terms:

in a	:	the terms that do not depend upon Δm
„ $b \cos \delta$:	„	„ „ „ „ „ „ „ Δn and X
„ $c \cos \delta$:	„	„ „ „ „ „ „ „ Y
„ a'	:	„ „ „ „ „ „ „ Z
„ b'	:	„ „ „ „ „ „ „ Y
„ c'	:	„ „ „ „ „ „ „ Δn and X

These correction-terms are calculated by means of values for the constants deduced from a preliminary solution:

<i>B-groups</i>	<i>F-groups</i>
$X = + 0''43$	$+ 0''43$
$Y = - 2''4$	$- 1''6$
$Z = + 1''9$	$+ 2''5$

They are then subtracted from the immediate results of the equations. The following table contains the results thus corrected. (See p. 83).

The figures in this table will now serve for the determination of the constants of precession and solar motion Δm , Δn , X , Y , Z , the actual unknown quantities of our problem. For this purpose, however, the relative weights of the differences in α and δ between KÜSTNER and the four zone-catalogues must first be deduced.

6. *Relative accuracy of the differences formed. Weights to be attributed to them.*

AUWERS²⁾ gives a table of the mean errors of the various zone-catalogues of the A. G. deduced from a comparison with ROMBERG. There are also values for the mean errors given in the zone-catalogues themselves. Both are given below p. 84.

¹⁾ These Proc. 18, 684, 693

²⁾ Astron. Nachr. 3842-44.

CORRECTED VALUES OF THE COEFFICIENTS.

Catalogue	BA	BE	BE'	FA	FE	FE'	F ₁ A	F ₁ E	F ₂ A	F ₂ E
I) COEFFICIENT a										
Be A	- 0''10	-0''12	-0''09	-0''51	-0''55	-0''44	-0''77	-0''66	-0''30	- 0''43
Be B	+0.25	-0.26		-0.79	-0.45					
Lei I	-0.82	-0.79		-1.07	-0.92					
Leiden	- 0.86	-0.37		-0.20	+0.35					
II) COEFFICIENT $b \cos \delta$										
Be A	+1.24	+0.78	+0.70	+0.52	+0.35	+0.27				
Be B	+0.60	+0.32		+0.29	+0.31					
Lei I	+0.01	+0.00		+0.84	+0.26					
Leiden	+0.11	+0.15		+0.34	+0.17					
III) COEFFICIENT $c \cos \delta$										
Be A	+4.21	+2.36	+2.39	+2.11	+1.60	+1.57				
Be B	+2.79	+1.79		+1.36	+0.70					
Lei I	+3.64	+2.94		+1.71	+1.70					
Leiden	+2.18	+1.39		+2.55	+1.91					
IV) COEFFICIENT a'										
Be A	-1.52	-1.29		-2.55	-2.01					
Be B	-3.39	-2.49		-4.22	-3.44					
Lei I	-1.10	-1.20		-3.23	-3.03					
Leiden	2.09	-1.54		-1.40	-0.78					
V) COEFFICIENT b'										
Be A	-0.73	-0.43		-0.73	-0.35					
Be B	-1.14	-1.09		-0.95	-0.84					
Lei I	-0.88	-0.86		-0.87	-1.14					
Leiden	-1.75	-1.33		-0.89	-0.75					
VI) COEFFICIENT c'										
Be A	-0.17	-0.16		-0.25	-0.17					
Be B	+0.45	-0.03		-0.12	-0.56					
Lei I	+0.69	+0.43		+1.00	+0.83					
Leiden	-0.09	-0.58		-0.33	-0.51					

6*

MEAN ERRORS OF THE CATALOGUES AND OF THE DIFFERENCES.

Catalogue	m.e. position		m. e. difference	m.e. diff. per annum		Weights of	
	zonecat	Küstner		$\Delta\alpha \cos \delta$	$\Delta\delta$	$\Delta\alpha \cos \delta$	$\Delta\delta$
a) according to AUWERS :							
Be A	0 ^s 034 0 ["] 47	0 ^s 021 0 ["] 29	0 ^s 040 0 ["] 55	0 ["] 022 0 ["] 021	1.99 2.18		
Be B	.025 .30	.020 .27	.032 .40	.028 .025	1.22 1.54		
Lei I	.043 .55	.022 .31	.048 .63	.031 .028	1.00 1.22		
Leiden	.050 .52	.020 .25	.054 .58	.029 .025	1.07 1.54		
b) according to data in the catalogues :							
Be A	0 ^s 034 0 ["] 45	0 ^s 021 0 ["] 29	0 ^s 040 0 ["] 54	0 ["] 022 0 ["] 021	1.62 1.78		
Be B	.027 .38	.020 .27	.034 .47	.029 .029	0.93 0.93		
Lei I	.037 .47	.022 .31	.043 .56	.028 .025	1.00 1.26		
Leiden	.044 .49	.020 .25	.048 .55	.026 .023	1.16 1.48		

As weights the means of those according to *a* and *b* are taken, namely :

Catalogue	Weight of	
	$\Delta\alpha \cos \delta$	$\Delta\delta$
Be A	1.8	2.0
Be B	1.1	1.2
Lei I	1.0	1.2
Leiden	1.1	1.5

7. *Determination of the actual unknown quantities.*

The correction-terms having been applied, the equation

$$a = \Delta m$$

now holds.

In the further calculations I have kept the B groups and the F groups apart, but for the rest I have simply taken the means of the results of the different methods. After this, means were formed from the four catalogues with the weights given in § 6. I thus obtained, always placing the 4 catalogues under one another in the same order, the following results for Δm .

Groups B	Groups F
— 0"10	— 0"52
0.00	— 0.62
— 0.80	— 1.00
— 0.62	+ 0.08
<hr/>	
Mean: — 0"33	— 0"51

These are corrections which should be applied to m of STRUVE-PETERS. To obtain the corrections for NEWCOMB's m the difference between the values for m PETERS-NEWCOMB should be added. NEWCOMB¹⁾ gives the following values:

Centennial precessional motion for 1850,

	m	n
PETERS-STRUVE	4607"63	2005"64
NEWCOMB 1896	4607.11	2005.11
(final value)		

From the differences PETERS—NEWCOMB:

in m	+ 0"52,
in n	+ 0.53,

it becomes evident that the values m and n of STRUVE-PETERS do not correspond to one another, when we adopt the most probable value for the planetary precession. I reduce my results therefore to NEWCOMB's values:

Corrections to NEWCOMB's m	
Groups B	Groups F
+ 0"42	+ 0'00
+ 0.52	— 0.10
— 0.28	— 0.48
— 0.10	+ 0.60
<hr/>	
Mean: + 0"19	+ 0"01

Finally attributing equal weights to the B and F groups.

B and F groups together

$$\Delta m \text{ (centennial) NEWCOMB} = + 0"10 \pm 0"13 \text{ (m e).}$$

The mean error is deduced from the comparison of the above 8 values for Δm with their mean.

From the equation

$$b \cos \delta = \Delta n \sin \delta + 0.93 X$$

X can be determined, if $\Delta n = - 0"16$ is substituted as deduced from the preliminary solution. The results for $0.93 X$ then are:

¹⁾ The Precessional constant, p. 10.

	Groups B	Groups F
0.93 X =	+ 0''96	+ 0''43
	+ 0.52	+ 0.36
	+ 0.04	+ 0.59
	+ 0.22	+ 0.35
Mean:	+ 0''52	+ 0''43
X =	+ 0''56	+ 0''46

From $c \cos \delta = - (0.93 + 0.20 \cos^2 \delta) Y$

Y may be determined. The following values were found:

	Groups B	Groups F
Y =	- 2''69	- 1''59
	- 2.08	- 0.94
	- 2.94	- 1.52
	- 1.66	- 2.08
Mean:	- 2''38	- 1''54

The equation

$$a' = - (0.93 + 0.10 \cos^2 \delta) Z$$

gives the unknown Z . The results are as follows:

	Groups B	Groups F
Z =	+ 1''45	+ 2''35
	+ 3.16	+ 4.10
	+ 1.14	+ 3.10
	+ 2.17	+ 1.30
Mean:	+ 1''92	+ 2''59

From $b' = 0.93 Y \sin \delta$

a second value for Y may be deduced.

I find the following values, in which the fact has been taken into account that the weights of the values for Y obtained from the 4 catalogues are very divergent in consequence of the factor $\sin \delta$:

	Groups B	Groups F
0.54 Y =	- 1''16	- 1''08
0.42 Y =	- 1.35	- 1.08
0.24 Y =	- 1.04	- 1.20
0.75 Y =	- 2.31	- 1.23
Mean: Y =	- 3''01	- 2''36

Finally from the equation

$$c' = \Delta n + (0.93 + 0.20 \cos^2 \delta) X \sin \delta$$

Δn can be deduced, if the value for X found from the R.A. is substituted in it.

I find thus for Δn (STRUVE-PETERS):

Groups B	Groups F
Δn Str.-Pet. = $-0''34$	$-0''36$
-0.03	-0.53
$+0.42$	$+0.81$
-0.66	-0.69
Mean: $-0''20$	$-0''24$

or, deducing corrections to NEWCOMB's n :

Groups B	Groups F
$\Delta n N_{90} = +0''19$	$+0''17$
$+0.50$	$+0.00$
$+0.95$	$+1.34$
-0.13	-0.16
Mean: $+0''33$	$+0''29$

B and F together: Δn NEWCOMB (centennial) = $+0''31 \pm 0''18$.

Another method of determining Δn and X consists in solving both unknowns at the same time from sets of two equations with two unknowns, that is from:

$$b \cos \delta = \Delta n \sin \delta + 0.93 X$$

and $c' = \Delta n + (0.93 + 0.20 \cos^2 \delta) X \sin \delta$.

In this way I find the following values for X and Δn (STRUVE-PETERS):

Groups B		Groups F		B and F
X	Δn	X	Δn	Δn
$+1''17$	$-0''54$	$+0''53$	$-0''39$	$-0''46$
$+0.49$	-0.00	$+0.56$	-0.57	-0.28
-0.14	$+0.60$	$+0.40$	$+0.82$	$+0.71$
$+0.51$	-0.64	$+0.79$	-0.88	-0.76

In connection with the weights given to the R.A. and the Decl. I attribute to the results from the 4 catalogues the weights 1.9, 1.2, 1.1 and 1.3. I then find as mean values:

Groups B	Groups F	B and F
$X = +0''60$	$+0''57$	
Δn Str.-Pet. = -0.21	-0.30	$-0''26$

therefore as correction Δn to NEWCOMB:

Groups B	Groups F	B and F
Δn (NEWCOMB) = $+0''32$	$+0''23$	$+0''27$

By substituting the final mean value of Δn (STRUVE-PETERS) = $-0''.24$ for the preliminary value $-0''.16$ in the equation

$$b \cos \delta = \Delta n \sin \delta + 0.93 X$$

a second approximation for X is obtained from the R.A. only. In this way I find as the mean value from the four catalogues

$$X = \begin{array}{cc} \text{Groups B} & \text{Groups F} \\ + 0''.58 & + 0''.48. \end{array}$$

The result for Δn from the Decl. only does not change perceptibly, if we substitute for X these final values in place of the approximate ones.

Finally I accept the means of both determinations of Δn and X as my final result.

8. Conclusions.

In the foregoing the following final values are found for the unknowns:

	Groups B	Groups F	B and F
Δm (NEWCOMB)	+ 0''19	+ 0''01	+ 0''10
Δn (NEWCOMB)	+ 0.32	+ 0.26	+ 0.29
X	+ 0.59	+ 0.52	
Y from the R.A.	- 2.38	- 1.54	
Y from the Decl.	- 3.01	- 2.36	
Mean (weights 2 and 1)	- 2.59	- 1.81	
Z	+ 1.92	+ 2.59	

Let us first consider the value of Δm , $+ 0''.10 \pm 0''.13$, and of Δn , $+ 0''.29 \pm 0''.18$. From both it is possible to deduce a correction of the luni-solar precession accepted by NEWCOMB; I find:

$$\text{from } \Delta m: \quad \Delta p = \frac{\Delta m}{\cos \varepsilon} = + 0''.11 \pm 0''.14,$$

$$\text{from } \Delta n: \quad \Delta p = \frac{\Delta n}{\sin \varepsilon} = + 0''.72 \pm 0''.45.$$

These values clearly show a difference, in the same direction as remains in the results found by NEWCOMB, even after correction for the systematic differences of distance. We now find.

$$\Delta p (\text{Decl.}) - \Delta p (\text{R.A.}) = + 0''.61 \pm 0''.47.$$

However, it is not very surprising to find such a difference occurring here. It is only 1.3 times as large as its mean error and

may for the greater part be accounted for by the influence which the accidental errors must have in the comparison of the zone-catalogues with KUSTNER's, in consequence of the small difference of epoch. With regard to the possible systematic errors.

a. errors due to magnitude-equations

b. an error in the adopted motion of the equinox

c. systematic errors in the fund. system dependent upon α and δ on the other hand, the research here detailed is certainly not behind other determinations of the constants of precession from faint stars.

As regards *a*, the errors due to magnitude have been eliminated in a very satisfactory way, undoubtedly better than has been possible in any other similar research, while the effect of the errors *b* and *c* does not depend upon the difference of epoch of the catalogues themselves.

The question as to whether to the system N_1 , also adopted by AUWERS, must be applied an appreciable correction of the form

$$\Delta E = \Delta E_0 + \Delta E' \times T,$$

in which $\Delta E'$ represents a correction to the centennial motion of the equinox, is discussed by NEWCOMB¹⁾. If a correction of this form is introduced, a corresponding one must be applied to the Δp from the A.R. namely:

$$\text{Corr. } \Delta p = + 1.09 \Delta E'.$$

Of the probable value of $\Delta E'$ NEWCOMB makes an estimate. He comes to the conclusion that we may assume $\Delta E' = + 0''30$. If we do that here also, our results become:

$$\Delta p (\text{R. A.}) = + 0''44 \pm 0''14,$$

$$\Delta p (\text{Decl.}) = + 0.72 \pm 0.45,$$

which values agree very satisfactorily with one another.

In order that I might form some opinion upon the question in how far systematic errors depending upon α and δ in the p.m. of the New Fundamental Catalogue of AUWERS could have exercised an influence upon the results, a comparison was made between the N. F. K. of AUWERS and the Fund. Cat. of NEWCOMB. On the basis of the data occurring in the N. F. K. of the Berliner Jahrbuch²⁾ a table was drawn up of the differences in μ_α and μ_δ (N. F. K.—NEWCOMB) for four groups of stars, corresponding in declination to the four zone-catalogues. Excluding a few very large differences I found as means:

¹⁾ The Precessional Constant, p. 69 a f.

²⁾ Veröffentlichungen des Königl. Astron. Rechen-Instituts No. 33, p. 100 et seq.

Differences in centenn. proper motion N. F. K. — Newcomb 1900

	$\Delta\mu_{\alpha}$	$\Delta\mu_{\delta}$
$\delta + 10^{\circ} - + 15^{\circ}$	$-0^{\circ}0057$	$-0''105$
$\delta + 15^{\circ} - + 20^{\circ}$	$+0.0154$	$+0.060$
$\delta + 20^{\circ} - + 25^{\circ}$	$+0.0003$	$+0.254$
$\delta + 30^{\circ} - + 35^{\circ}$	$+0.0028$	$+0.210$

The values of $\Delta\mu_{\alpha}$ and $\Delta\mu_{\delta}$ were smoothed by formulae of the form:

$$\Delta\mu_{\alpha} = a + b\delta$$

$$\Delta\mu_{\delta} = a' + b'\delta$$

this is advisable as the zone-positions are based upon fundamental stars some of which lie outside the zones. I found:

$$a = +0^{\circ}0010 \quad b = +0^{\circ}0001$$

$$a' = -0''216 \quad b' = +0''015$$

and with this the smoothed values

$\Delta\mu_{\alpha}$	$\Delta\mu_{\delta}$
$+0^{\circ}002$	$-0''03$
$+0.003$	$+0.05$
$+0.003$	$+0.12$
$+0.004$	$+0.27$

These values are subtracted from the differences for each star. From the residual values 2-hour-groups according to R.A. were formed for the four declination-groups together.

In the following table are collected the mean values for the two-hour-groups, where 0^h represents the group from R.A. 23^h to 1^h etc.

DIFFERENCES N.F.K. — NEWCOMB DEPENDENT UPON THE A.R.

α	$\Delta\mu_{\alpha}$	$\Delta\mu_{\delta}$	Stars
0 ^h	$+0^{\circ}004$	$-0''11$	10
2	-0.032	$+0.12$	7
4	-0.004	$+0.03$	16
6	-0.000	$+0.01$	10
8	$+0.011$	$+0.11$	9
10	$+0.027$	$+0.01$	11

α	$\Delta\mu_\nu$	$\Delta\mu_\delta$	Stars
12	+ .009	+ .04	8
14	+ .019	- .12	6
16	+ .013	+ .02	10
18	+ .001	+ .23	8
20	- .016	- .14	10
22	- .035	- .00	9

These values I have represented by formulae of the form:

$$\Delta\mu_\nu = x \sin \alpha + y \cos \alpha$$

$$\Delta\mu_\delta = x' \sin \alpha + y' \cos \alpha$$

attributing equal weight to each 2-hour group. I found:

$$x = + 0^s.002 \quad y = - 0^s.021$$

$$x' = + 0''.023 \quad y' = - 0''.012,$$

so that

$$\Delta\mu_\nu (\text{N. F. K.} - \text{NEWCOMB}) = \text{smoothed value} + x \sin \alpha + y \cos \alpha$$

$$\Delta\mu_\delta (\text{N. F. K.} - \text{NEWCOMB}) = \text{smoothed value} + x' \sin \alpha + y' \cos \alpha.$$

If, therefore, my results which hold good for the system of the N. F. K. of the Berliner Jahrbuch, are to be reduced to the system of NEWCOMB's catalogue, the above quantities must be added to the differences in α and δ per 100 years, with reversed sign.

These systematic corrections are therefore:

$$\text{in } \Delta\alpha \text{ per 100 years: } \begin{cases} -0''.03 \\ -0''.04 \\ -0''.04 \\ -0''.06 \end{cases} \left\{ -0''.033 \sin \alpha + 0''.314 \cos \alpha \right\} \begin{cases} \text{Lei I} \\ \text{Be A} \\ \text{Be B} \\ \text{Leiden} \end{cases}$$

$$\text{in } \Delta\delta \text{ per 100 years: } \begin{cases} +0''.03 \\ -0''.05 \\ -0''.12 \\ -0''.27 \end{cases} \left\{ -0''.023 \sin \alpha + 0''.012 \cos \alpha \right\} \begin{cases} \text{Lei I} \\ \text{Be A} \\ \text{Be B} \\ \text{Leiden} \end{cases}$$

The addition of these corrections changes my values for the unknowns in the following way

corr. Δm	per century	
		- 0''045
„ X	„ „	- 0.03
„ Y(R.A.)	„ „	- 0.26
„ Z	„ „	+ 0.11
„ Y(Decl.)	„ „	- 0.07
„ Δn	„ „	+ 0.01

The results then become:

$$\Delta m + 0''055$$

$$\Delta n + 0.30$$

	Gr. B	Gr. F
X	+ 0"55	+ 0"49
Y (R.A.)	- 2.64	- 1.80
Y (Decl.)	- 3.08	- 2.43
mean (weight 2 and 1)	- 2.79	- 2.01
Z	+ 2.03	+ 2.70

Let us now examine first what is found for the luni-solar precession p .

I find from Δm : $\Delta p = + 0".06$

from Δn : $\Delta p = + 0".75$

or, if we adopt the correction to the motion of the equinox,

from Δm : $\Delta p = + 0".39$

from Δn : $\Delta p = + 0".75$

from which, again combining with weights 2 and 1 :

from R.A. and Decl. : $\Delta p = + 0".51$.

From the two values for Δp , found if we adopt AUWERS's New System, follows in the same way

from R.A. and Decl. $\Delta p = + 0".53$.

The agreement of the two results makes it probable that systematic errors dependent upon α and δ cannot have a great influence upon our results.

Taking the mean, therefore, I get as final result

$$\Delta p_{\text{NEWCOMB}} = + 0".52.$$

As NEWCOMB's final result of 1896 remains quite unchanged by taking the systematic differences of distance of the stars into account (These Proc. 18. 692) my result is 0".5 greater than his.

From my value for Δp follows

$$\Delta m_{\text{NEWCOMB}} = + 0".48$$

$$\Delta n_{\text{NEWCOMB}} = + 0".21$$

The values for the yearly precessional motions which follow from the research here detailed are therefore :

Yearly precessional motions for 1850 :

$$p = \text{lunisolar precession} = 50"3736$$

$$p' = \text{general precession} = 50"2505$$

$$m = \text{precession in R. A.} = 46"0759$$

$$n = \text{precession in Decl.} = 20"0532$$

$$P = \text{NEWCOMB's constant} = 54"9124$$

In the second place we will discuss the results obtained for the parallactic motion, if we successively adopt the two systems.

For the components of the parallactic motion the following values are found :

	In AUWERS's system		In NEWCOMB's system :	
	Groups B	Groups F	Groups B	Groups F
X	+0''59	+0''52	+0''55	+0''49
Y	-2.59	-1.81	-2.79	-2.01
Z	+1.92	+2.59	+2.03	+2.70

From the values in this table I deduce the following values for the coordinates of the apex, A and D, and for the total solar motion and its projection upon the plane of the equator.

	In AUWERS's system :		In NEWCOMB's system :	
	Groups B	Groups F	Groups B	Groups F
A	282°5	286°0	281°1	283°7
	18 ^h 50 ^m	19 ^h 4 ^m	18 ^h 44 ^m	18 ^h 55 ^m
$\sqrt{X^2+Y^2}$	2''65	1''88	2''84	2''07
D	+35°9	+54°0	+35°5	+52°5
$\sqrt{X^2+Y^2+Z^2}$	3''28	3''20	3''49	3''40

Let us first consider the results obtained for the R.A. and Decl. of the apex. It is not possible here to institute a critical comparison of my results with those of others which would in itself form a research. For the sake of orientation in the problem I will merely quote some results obtained by previous investigators along the same lines.

The results deduced for A and D from the Bradley stars by NEWCOMB and corrected for the systematic difference of distance, according to the research published in these Proceedings, by -1° and $+2^\circ$ respectively were 273° and $+33^\circ$; in the same way the results of L. SROUVE (corrected by NEWCOMB) become 272° and $+37^\circ$. From the comparison of the whole material of his Albany-zone with LALANDE and BESSEL, BOSS found for stars of a mean magnitude $8^m.7$: 264° and $+54^\circ$ ¹⁾, while later on²⁾ he accepted as final result

¹⁾ A. J. 9, 28

²⁾ A. J. 21, 168:

from various researches for stars $8^m.5$ with small P.M.: 279° and $+45^\circ$.

My results, which apply to mean magnitudes (photom. magnitudes of KÜSTNER), of $7^m.25$ for the bright group and of $9^m.19$ for the fainter group, remain almost the same, whether we take AUWERS's system or NEWCOMB's as basis. Comparing them with the above, it is seen that my values for A belong to the greatest so far obtained, while those for D for my bright group agree very well with those from the BRADLEY stars and the results for my faint group do not differ much from the corresponding ones of BOSS. The large difference between the value for D in my two groups, which is the result of the abnormal relation of the two values found for the Z -component, is a striking result, to which I shall return further on.

In the second place, my results for the amount of the parallactic motion must be further considered, both those for the projection of this motion upon the plane of the equator and those for the total motion. We observe first that, for both motions, the reduction to NEWCOMB's system gives somewhat larger values than that to AUWERS's system. Naturally both for the bright and for the faint group.

For the equatorial motion the ratio of group B to group F is according to the two systems $1:0.71$ and $1:0.73$, while the ratio between the mean distances of the groups, according to the later researches (Comp. KAPTEYN and WEBERSMA Publ. Gron. **24**, 15), should be $1:0.63$. Here the agreement is, therefore, fairly good, but the result is totally different, if we consider the total motion. For this we find for the faint group results which are only 3% smaller than those for the bright group.

However, before endeavouring to draw any conclusion from this, we must consider the significance of my results, in connection with the methods used concerning the exclusion of stars of large proper motion. As mentioned above I made one set of solutions (method A) in which practically only the double stars were excluded (besides the double stars for the four catalogues together only 21 stars) and another set (method E) in which a considerable number of stars with a somewhat large P.M. were excluded. Finally the mean results from these methods were accepted as the final result.

This method was certainly justifiable, where a determination of the precessional motion was aimed at, and perhaps is so still, when we only desire to derive the coordinates of the apex of the parallactic motion. If we wish, however, to determine the amount of this motion, it will be seen that the significance of the results beco-

mes uncertain by the method used. It is necessary, therefore, to consider the results according to the methods A and E separately.

For this purpose I calculated, from the values of the 6 coefficients, after correction for the subsidiary terms, the components X, Y, Z of the solar motion for the A and E groups of each of the catalogues separately, and combined these results with the previously adopted weights.

In this way I found adopting the system of AUWERS's N. F. K.

	BA	BE	FA	FE
X	+0''74	+0''42	+0''62	+0''34
Y (R. A.)	-3.02	-1.74	-1.79	-1.29
Y (Decl.)	-3.34	-2.68	-2.55	-2.17
Y (mean; weights 2 and 1)	-3.13	-2.05	-2.04	-1.58
Z	+2.13	+1.70	+2.89	+2.29

and for the further constants derived from these

	BA	BE	FA	FE
A	283°3	281°6	286°9	282°1
	18 ^h 53 ^m	18 ^h 46 ^m	19 ^h 8 ^m	18 ^h 48 ^m
$\sqrt{X^2+Y^2}$	3''22	2''09	2''13	1''62
D	+33°4	+39°1	+53°6	+54°7
$\sqrt{X^2+Y^2+Z^2}$	3''86	2''70	3''59	2''80

It may be regarded as a satisfactory result of the last calculation that the coordinates of the apex, gained by the A and E methods, do not differ greatly, and also differ only slightly from my previous results. On the other hand, the result that the Z-component is found larger for the faint than for the bright stars, becomes even more striking, now that it proves to hold good for the results deduced separately by the A and E method. Further, as was to be expected from former results, the *amount* of the parall. motion gained by the two methods differs considerably, which again shows that the parall. motion increases greatly with the total P. M. The

results of the method *A* are the only ones that have a sharply defined meaning. They give us the parall. motions for the mean of the stars of magnitudes 7.25 and 9.19.

We will, therefore, consider these only, and we will deduce, beside the results above obtained for AUWERS's system, those which are found, if we adopt NEWCOMB's, which can be done at once by applying to the 3 components the differences deduced above.

I then find, repeating the first mentioned values in order to facilitate the comparison:

	In AUWERS's System		In NEWCOMB's System	
	Group BA	Group FA	Group BA	Group FA
X	+ 0''74	+ 0''62	+ 0''70	+ 0''58
Y	- 3.13	- 2.04	- 3.33	- 2.24
Z	+ 2.13	+ 2.89	+ 2.24	+ 3.00
A	283°3	286°9	281°8	284°5
$\sqrt{X^2+Y^2}$	3''22	2''13	3''40	2''31
D	+ 33°4	+ 53°6	+ 33°4	+ 52°4
$\sqrt{X^2+Y^2+Z^2}$	3''86	3''59	4''07	3''79

Here we see again that all the essential features of our results are independent of the choice of the fundamental system.

For the ratio between the equatorial motions for the bright and the faint group we now find 1 : 0.66 or 1 : 0.68, or for a difference of one magnitude 1 : 0.81 or 1 : 0.82, which agrees very satisfactorily with the ratio of the distances given by KAPTEYN and WEERSMA 1 : 0.63 or for one magnitude 1 : 0.79. All agreement, however, disappears again, when we consider the total motion, and thus include the *Z*-components. In my last results also, the motion in the *Z*-direction is found to be much greater for the faint stars than for the bright ones and even if we take into consideration that of the centennial motions here derived, barely a fifth part has actually been observed, our result still remains very striking. If we consult the results yielded by the four catalogues separately, we find that the Leiden zone gives a normal result, namely faint : bright = 0.67 : 1, while from the 3 others we derive a very abnormal ratio. Other investigations, which gave greater values for *D* deduced from faint stars, than when bright stars were used, might point to abnormal circumstances in

the same direction. The result here found is, however, more striking, for, as the declinations were determined in exactly the same way for faint and for bright stars, the greater value for Z (the constant term in $\Delta\delta$) which the former give, cannot be ascribed to constant errors of the declinations of the catalogues used. If systematic errors of the catalogues are to be made responsible for our result, it can only be the consequence of residual magnitude-errors in declination.

This point certainly deserves further investigation. Another point that has not been investigated so far is the possible presence in the differences KÜSTNER—ZONECATALOGUES of terms dependent upon multiples of α .

Mathematics. — “*Pencils of twisted cubics on a cubic surface*”.

By Prof. JAN DE VRIES.

(Communicated in the meeting of March 25, 1916).

1. The straight lines of a bisextupel of a cubic surface Φ^3 will be indicated in the usual way by a_k and b_k ; the remaining straight lines by c_{kl} . In order to arrive at the wellknown representation of Φ^3 on a plane τ , we lay τ through the straight line c_{12} and consider b_1, b_2 as directrices of a bilinear congruence of rays. Any point P of Φ^3 is then represented by the intersection P' , on τ , of the ray passing through P . The intersections A_1, A_2 of b_1, b_2 represent a_1, a_2 , whereas a_3, a_4, a_5, a_6 are represented by their intersections A_3, A_4, A_5, A_6 . The representation of the straight line b_k is the conic β_k , which is determined by the five *cardinal points* A_l ($l \neq k$); the straight line c_{kl} is represented by $A_k A_l$. From this representation it may be deduced that any twisted cubic ϱ^3 lying on Φ^3 has a sextuple as chords and is not intersected by the associated sextuple.

2. A ϱ^3 having the sextuple b_k as bisecants is represented by a straight line of τ ; a plane pencil with vertex C' is therefore the image of a system of ϱ^3 all passing through the point C . Such a system we shall call a *pencil*; C we call the *singular point* of the pencil (ϱ^3). All ϱ^3 rest on the 15 straight lines c_{kl} and have the straight lines b_k as chords¹).

To (ϱ^3) belong *six degenerated figures*. For the straight line $C'A_k$

¹) In my paper “A simply infinite system of twisted cubics” (These Proceedings Vol. XVIII p. 1464) I arrived at the consideration of such a pencil in an entirely different way

is the image of a figure consisting of the straight line a_k and a conic ϱ^2_k in the plane $(C'b_k)$, which is intersected by a_k .

On the curve ψ^3 , along which Φ^3 is intersected by a plane ψ , the pencil (ϱ^3) determines an involution I^3 .

If a tangent plane is taken for ψ , ψ^3 becomes rational, the involution I^3 has in that case four pairs in common with a central I^3 . To it belongs, however, the pair of points lying in the node of ψ^3 and arising from the ϱ^3 , which touches at ψ there. So there are three pairs of points that send their connectors through an arbitrary point. From this it ensues that the *bisecants of the curves ϱ^3* will form a *cubic complex of rays, Γ^3* . C is evidently *cardinal point of Γ^3* , for that point bears ∞^2 rays.

The planes of the *six* conics ϱ^2_k are *cardinal planes*.

3. The rays of the complex passing through a point T form a *rational cubic cone*, which has the straight line TC as *nodal edge*; for it intersects Φ^3 moreover in two points, so that it is chord of two ϱ^3 .

The ends U, U' of the chords forming this cone lie on a twisted curve τ^3 , which has a node in C ; for any plane passing through TC contains apart from that edge only two more points U .

If TC becomes tangent of Φ^3 , the nodal edge passes into a *cuspidal edge*. The locus for the vertices of *complex cones with a cuspidal edge* is therefore the *enveloping cone* of Φ^3 , which has C as vertex, consequently a *cone of order four*.

For a point N on Φ^3 the complex cone degenerates into the quadratic cone that projects the ϱ^3 determined by N , and a plane pencil of which the plane ν passes through C .

If N lies on one of the conics ϱ^2_k , the complex cone consists of three plane pencils, of which one lies in the plane of the conic, one in the plane (Na_k) .

If N is taken on one of the singular bisecants b_k the plane pencil (N, ν) consists of chords of ϱ^2_k .

In a plane ν the *complex curve* degenerates into the *plane pencil* with vertex N and the twice to be counted *plane pencil* with vertex C ; for a straight line passing through C is chord of two ϱ^3 .

4. The tangents out of N at the cubic ν^3 , which ν has in common with Φ^3 , are at the same time tangents t at curves ϱ^3 . This holds also for the straight line that touches ν^3 in C ; but the latter, as ray of the congruence $[t]$ is to be counted twice.

From this we conclude that the *class* of $[t]$ is *six*.

Also the tangent in N at the ϱ^3 , which passes through N , must be counted for two rays of $[t]$; consequently the *order* too is equal to *six*.

This may also be proved as follows. The pairs of points U, U' of the curve τ^6 are projected out of a straight line l by a pencil of planes in involutorial correspondence (6,6), in which the plane (lT) represents a sextuple coincidence. As the remaining coincidences arise on account of the coincidence of U' with U , T bears *six* tangents of curves ϱ^3 .

C is evidently a *singular point* of *order one* for the congruence $[t]$; the tangent plane in C at Φ^3 is the *singular plane* belonging to it. The planes of the six conics ϱ^2_L are *singular planes* of *order two*. The six straight lines b are *double rays*.

5. Analogous considerations hold for pencils (ϱ^3) on a *nodal* cubic surface. The representation is then simply brought about by central projection out of the conical point. The curves ϱ^3 now have one of the six straight lines $a(b)$ passing through the conical point and four straight lines c as chords, or they pass through the conical point and have three straight lines a and three straight lines c as chords.

Physiology. — “*A new group of antagonizing atoms.*” I. By T. P. FEENSTRA. (Communicated by Prof. Dr. H. ZWAARDEMAKER).

(Communicated in the meeting of April 28, 1916).

It is a matter of common knowledge that a sodium chloride solution in the concentration of RINGER'S mixture arrests the action of the heart some time after the circulating fluid has been administered, and also that contraction can be restored by the addition of potassium chloride and by calcium chloride.

These two salts remove the toxic effect of sodium chloride.¹⁾ A normal action of the heart is obtained only if the three salts together with sodium bicarbonate are present in the circulating fluid in a definite concentration as in bloodserum. Augmentation or diminution of the amount of one of the constituents of the fluid induces an abnormal action of the heart, which will slow down to a standstill, when the difference becomes too great. The relative apportionments of the three salts must, therefore, be definite and fairly constant.

¹⁾ Journal of Physiol. Vol. III p. 380, Vol. IV pp. 29 and 222, Vol. V p. 247.

With regard to potassium we can say that the ratios $\frac{C_{KCl}}{C_{NaCl}}$ and $\frac{C_{KCl}}{C_{CaCl_2}}$ must be constant.

Though J. LOEB was the first to make a thorough investigation of the whole subject of the antagonism of salts¹⁾, RINGER had already then made out that the salts in blood serum must, in their concentration, stand to one another in a definite proportion. He demonstrated at the same time that this also applies to rubidium chloride which may in every respect take the place of potassium chloride.²⁾ — I have succeeded in detecting a new group of salts that can replace the potassium constituent of RINGER's mixture, demonstrating at the same time their antagonism to the other constituents. — I experimented upon the hearts of *Rana temporaria*, *Rana esculenta* and *Anodonta fluviatilis*.

The heart of the frog was exposed after the destruction of the central nervous system; then an incision was made in the sinus and the septum atriorum was destroyed. A KRONECKER cannula was inserted³⁾ and ligatured to the atrium. When the heart was thus tied to the cannula and was completely removed from the body, the cannula was connected to the circulating apparatus. This apparatus was composed of some flasks after MARIOTTE, each containing one of the liquids to be used and each communicating singly with the cannula through the tube. Clamps were applied to enable us to send the liquids separately through the heart. The tubes were as short as could be, in order to observe directly the changed action of the heart with every separate circulating fluid. This enabled us also to approximate the time required by the heart for its reaction on any of the circulating fluids. The pressure was in this case maintained at 90 mm. while the mean temperature was 13° C.

By suspending the ventricle the contractions were registered on a kymographion.

In preparing the liquids used we started from a mother solution consisting of

aq. dist.	1000.—
chloret. natric.	7.—
chloret. calcic.	0,2
bicarb. natric.	0,2
glucose	1.—

¹⁾ J. LOEB in G. OPPENHEIMER, Handb. der Biochemie Vol. IIa p. 104.

²⁾ Journal of Physiol. Vol. IV p. 370.

³⁾ TIGERSTEDT, Lehrbuch der Physiol. des Kreislaufes 1893 p. 154.

This solution, which contains all the substances (except potassium chloride) of which LOCKE-RINGER's solution is composed, might be called a "potassium-free RINGER's mixture". We will, for convenience' sake, denote it in this paper by the symbol R.-K.

From this solution we first made RINGER's mixture by adding 100 mgrms of potassium chloride per litre. If we allowed R.-K. to run through a frog's heart, it was brought to a standstill in diastole after an interval different for each heart. The shortest interval noted was in the neighbourhood of 10 minutes, whereas another heart stopped beating only after five quarters of an hour; with the remaining hearts the times varied between these two extremes. If we subsequently sent the same solution with an addition of 100 grms. of potassium through the heart its normal pulsation was restored spontaneously. Obviously the absence of potassium had brought about the arrest of the heart.

Of the new group we first examined the uranium compounds. After tying up the heart and allowing RINGER's mixture to pass through it for about 15 minutes, in order to completely restore its normal beats, it was brought to a standstill with R.-K. Then a stream of R.-K. to which 25 mgrms of uranium-nitrate ($U(NO_3)_4$) per litre had been added was circulated through the heart, which resumed its beats regularly and spontaneously after an average interval of about five minutes, just as at the beginning of the experiment when RINGER's mixture was administered.

This phenomenon I observed in 16 different experiments; to my knowledge there was no case in which the uranium containing R.-K. remained inoperative. What I did observe was, that, if the heart was fed with the ordinary RINGER's mixture subsequently to the administration of uranium-containing R.-K., the heart immediately stopped beating in diastole, and could be made to resume its normal function only either by R.-K. or by uranium-containing R.-K. The standstill which in this case was induced by the application of RINGER's mixture, occurred almost directly after the beginning of the inflow.

If the heart began to pulsate again after its arrest, this occurred abruptly, the contraction and the electrocardiogram regaining at once their normal extent and frequency, while the tonicity was not modified in the process. Here, therefore, it was a case of "all-or-none". The contractions also persisted as at the beginning of the experiment.

If, however, the circulation of R.-K. had not removed a sufficient amount of potassium chloride from the heart at the beginning of the experiment, in consequence of the standstill being incomplete at this juncture, the cardiac action was not restored, neither with uranium-

containing R.-K. nor with the ordinary RINGER's mixture administered after it. A prolonged circulation of uranium-containing R.-K. caused the heart to resume its normal beats after intervals about similar to those observed in the above experiment of arresting the heart's action by means of R.-K.

In three cases the heart, which after the ligature did not resume its beats with the ordinary RINGER's mixture, acted regularly with uranium-containing R.-K.

In the first place we now tried to find out if this unexpected action of uranium nitrate might perhaps be due to contamination with potassium. If this were so the contamination could not possibly be more than 5 perc., as was borne out by our investigation ¹⁾. However, as an addition of 10 mgrms of potassium chloride to R.-K. did not act favourably upon the heart, it appeared that an action of potassium was out of the question.

In the second place we tried to ascertain whether the effect of uranium nitrate might be ascribed to uranium X, which is invariably present in chemically pure preparations of uranium-compounds. Therefore the uranyl nitrate, which acts like uranium nitrate, was freed from uranium X after SODDY and RUSSELL's method ²⁾. This uranium-X-free uranyl nitrate then appeared to exert the action just as the uranyl nitrate, which had not been purified after the same method.

The antagonizing action of calcium chloride on the toxic effect of potassium chloride has been carefully observed by J. LOEB ³⁾.

As with regard to this subject, this investigator experimented upon *Fundulus*, he obtained quantitative results that could not be obtained in my experiments upon an organ very sensitive to osmotic pressure.

In RINGER's mixture used by me the number of the molecules of the two salts potassium chloride and calcium chloride are in the ratio of 1 : 1.

If in RINGER's mixture we substitute uranyl nitrate for potassium chloride the ratio of the molecules is



If we add 50 grms instead of 25 grms of uranyl nitrate per litre to R.-K. it induces a standstill in diastole. This then is the limit of the toxic action of a definite quantity of calcium salt.

In other words a ratio of the molecules :

¹⁾ I wish once more to express my thanks to Prof. SCHOORL for enabling me to ascertain this with the aid of a spectroscope of the Pharmaceutical Laboratory.

²⁾ Phil. Mag. Bd. XVIII, 6 Series, 1909, p. 623.

³⁾ Bioch Zeitschr. Bd. 32, S. 308.

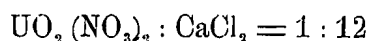

is poisonous. Anyhow the quotient: $\frac{C_{\text{UO}_2(\text{NO}_3)_2}}{C_{\text{CaCl}_2}}$ must be smaller than $\frac{1}{12}$.

If besides 50 mgrms of uranyl-nitrate we add to R.-K. 200 mgrms of calciumchloride per litre, the circulation produces a normal action of the heart. If in this case the heart begins to pulsate again, the pulsations are quite normal from the very outset, as described above for the smaller antagonizing doses ¹⁾.

Because the sodium chloride in RINGER's mixture is present in such a concentration as to interfere with reliable quantitative data of the antagonism $\frac{C_{\text{UO}_2(\text{NO}_3)_2}}{C_{\text{CaCl}_2}}$ ²⁾, I was obliged in this phase of the experiment to confine myself to ascertaining that in RINGER's mixture the calcium chloride obviates the toxic effect of uranyl- and uranium-nitrate.

The antagonism of $\text{UO}_2(\text{NO}_3)_2$, for CaCl_2 could be stated also in the anodonta fluviatilis. Quantitative data, however, could not be obtained with this laboratory animal, as in this case the quantity of body fluid was difficult to determine, so that at the pipetting of a uranyl-nitrate solution of definite strength the concentration of this salt in the body fluid is not known. On opening the shell the heart was prepared so as to enable it to continue its pulsations in the body fluid. On pipetting three drops of a 3 perc. uranyl-nitrate solution into this fluid a standstill ensued, which was followed again by pulsation after the addition of 24 drops of a 3 perc. calcium chloride solution. When this experiment was repeated some time in succession, the cardiac action was stopped at length, and could be restored again only by adding some water. Through repeated pipetting of salts the osmotic pressure had obviously grown too powerful for a normal function of the heart ³⁾.

J. LOEB holds that ion-proteins have something to do with the antagonistic action of salts. He suspects the cations and the anions of the salts to combine with the ion-proteins. The physico-chemical

¹⁾ RINGER has already reported that the calcium in the solution, named after him, may be substituted by strontium. In connection with what has been described in the text Mr. W. H. JOLLES for the last few weeks studied the displacement of Calcium by strontium as an antagonist for Uranium. Strontium here also appeared to be a fit substitute for calcium.

²⁾ Cf. J. LOEB, Bioch. Zeitschr. Bd. 32, S. 308.

³⁾ Whether sodium chloride was at all antagonized by potassium chloride and uranium salts could not be made out, as in that case the osmotic pressure is modified too much to effect a normal cardiac action.

condition of the so-called "Eiweissalze" then depends on the properties of the anion or the cation ¹⁾.

In a later publication, however, he communicates that the opposed charges of cations and anions do not come into play here ²⁾; he does believe though in a relationship between the action and the valency of the cation, viz. that the antitoxic effect increases with the valency of the cation ³⁾.

As regards uranium there is, however, no ground for attributing its effect to the valency of the cation, for, then there must be a quantitative difference in the doses of the bivalent uranylion and the quadrivalent urano-ion, which difference was not revealed in my experiments. Consequently if neither the charge nor the valency play any part here, the only conclusion to be drawn is that the uranium-atom must be present in the ion.

This atom then has a property that determines its action in RINGER's mixture. This action is antagonistic and stimulating.

A special investigation also taught me that the other elements of this group of the periodical system do not act likewise. I hope soon to be able to point out a new element possessing the peculiar property of potassium, rubidium and uranium, discussed in this paper.

Anatomy. — "*The relation of the plus de passage of GRATIOLET to the ape fissure*". By Dr. D. J. HULSHOFF POL. (Communicated by Prof. C. WINKLER).

(Communicated in the meeting of April 28, 1916).

In a previous publication ⁴⁾ which I wrote, I came amongst other things to the conclusion, that the apofissure is an inconstant furrow, and that, in case it should be formed, it only takes place after the other principal fissures have reached total development. Moreover I explained, that not only in the different monkey species the fissura simialis can be formed in different places, but also that in the same species, the spot, within certain limits, can change.

For instance one finds in semnopithecii and macaci the $m + m'$ sulcus (s. par. occ. lat.) at one time on the frontal face of the ape fissure, at another time on the back of it, what naturally

¹⁾ Bioch. Zeitschr. Bd. 36, 1911 S. 279.

²⁾ Journal of Biol. Chem. Vol. XIX, p. 431

³⁾ PFLÜGER's Archiv. Bd. 88, S. 68.

⁴⁾ HULSHOFF POL. D. J. The fissura simialis in embryos of Semnopithecii. These Proc. XVIII, p. 1571.

proves, that not always the same part of the brainsurface is pushed downwards.

I also found out, that the ape fissure is formed when at a certain foetal period the occipital part of the brain begins to develop stronger than the preceding part, and consequently the latter is pushed downwards.

According to the centre of overgrowth (greater growth) lying more proximally or more distally, also the line of curvation, where the operculisation is going to appear (ape fissure), will be placed more to the front or more to the back.

It is also possible that the centre of overgrowth is placed more medially or either laterally.

This difference in localisation which influences the place of the curvature where the apefissure will be formed, will be of importance for the origin of the plis de passage.

As I pointed out the larger growth of the occipital lobe, compared to the preceding part, being the cause of origin of the fissura simialis, of course the possibility is not excluded, that also other instances help to form that sulcus.

The more these instances co-operate, the more complicated the process will be and the more intricate the aspect of the plis de passage is going to be.

To well comprehend this, it is desirable to bring to mind in a few words, what has been written about the plis de passage.

As far as I know, GRATIOLET¹⁾ has been the first that has treated the subject in particulars.

Citing ZUCKERKANDL²⁾, GRATIOLET makes a difference between four outer and two inner plis de passage.

The first and second outer or lateral pli de passage lie in the fissura parieto-occipitalis and connect the lobus parietalis with the occipital part. The third and fourth outer or lateral plis de passage lie *superficially* and should connect the second temporal convolution with the occipital lobe.

This view of GRATIOLET dates from 1854 and therefore it is desirable, in order to prevent confusion, to add a few alterations, without changing however his meaning.

For instance neither GRATIOLET, nor FLATAU and JACOBSON³⁾

¹⁾ GRATIOLET. Memoires sur les plis cérébrales de l'homme et des Primates. Paris 1854.

²⁾ ZUCKERKANDL, E. Zur Morphologie des Affengehirnes. Zeitschr. f. Morph. u. Anthr 1903.

³⁾ FLATAU C. u. JACOBSON L. Handbuch der Anatomie des Centr. Nervensyst. der Säugeth. Berlin 1899.

made a difference between the fissura parieto-occipitalis lat., and the ape-fissure. According to them, these sulci are to be considered as one.

The researches of KUKENTHAL and ZIEHEN¹⁾, KOHLBRUGGE²⁾, ZUCKERKANDL³⁾ and myself⁴⁾ however have pointed out, that a sharp distinction between those two sulci has to be made.

Although the sulcus parieto-occipitalis lateralis ($m + m'$ KUKENTHAL and ZIEHEN) in cynopithecini will nearly always be found in the ape fissure (K.), yet it may not be identified with it.

In the interpretation of GRATIOLET therefore this change has to be made, that the first two plis de passage do not lie in the fiss. par. occ. lat. but in the fissura simialis.

His view about the 3rd and 4th pli de passage can remain unchanged.

As to the two inner or medial plis de passage, the upper should be lying in the fossa par. occ. medialis, while the lower remains on the surface.

The upper originates from the top of the praecuneus, then runs downwards, afterwards climbs to the top of cuneus, where it is united to the 1st lateral pli de passage.

The lower unites the lower part of the cuneus with the base of the praecuneus and it forms partially the upper ridge of the fissura calcarina. This convolution is called at present the gyrus cunei of ECKER.

It is comprehensible that after GRATIOLET the plis de passages have often been the subject of study.

As however the sulci in general, and those of the occipital part in particular show a number of varieties, as moreover the material, which was examined, gradually took greater dimensions, then it is not strange that the conceptions about the plis de passage altered.

It would take me too long to go into particulars with respect to the opinions and contradictions met with, and therefore it will suffice to communicate only the most interesting items of them.

BISCHOFF is of opinion that between the first outer (parietal) and upper (medial) pli de passage, there does not exist a difference. If the first is drawn into the depth, then it continues into the second. If it lies on the surface then the second does not exist in reality.

1) KUKENTHAL, W. u. ZIEHEN TH. Untersuchungen über die Grosshirnfurchen der Primaten, Jenaische Zeitschr. Bd 27, 1895.

2) KOHLBRUGGE, J. H. F. Die Variationen an den Grosshirnfurchen der Affen mit besonderer Berücksichtigung der Affenspalte. Zeitsch. f. Morph. u. Anthr. 1903.

3) Note 2 p. 105.

4) l. c.

BISCHOFF also thinks that there are monkeys in which the first pli de passage is not present. FLATEAU and JACOBSON join in principle his view.

This opinion was attacked by others and in particular it was ZUCKERKANDL¹⁾, who gave his fullest attention to the plis de passage.

Not only does he point out, pg. 286, how the 3rd outer pli de passage, which according to GRATIOLET should be lying on the surface, can also be found in the depth of the ape-fissure, but he also describes to us a three-rayed figure, which should develop by the union of the 1st and 2nd lateral plis de passage and he plans a hypothesis about the way of origin of the 1st lateral pli de passage out of the 2nd.

As to the presence of the 3rd lateral pli de passage in the ape-fissure, instead of on the surface of the hemisphere, he points out, that this is only possible, when the ape-fissure prolongs in caudal direction and is united with the s. occipitalis (b).

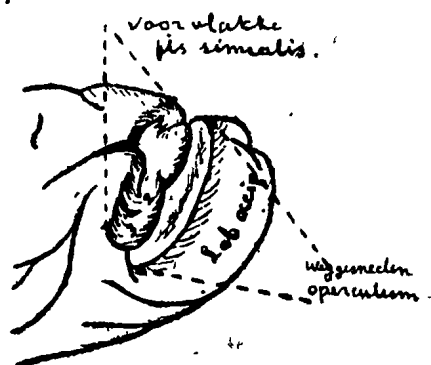

voorvlakte = frontal face
weggesneden = resected
Fig. 1.

The three-rayed form of these plis de passages one finds reproduced most clearly on his fig. 2, of which a reproduction is given (fig. 1). The names in it are added to it by me, the figures by ZUCKERKANDL. He points out, that the first pli de passage (1) is curved and the same is also the case with the second pli de passage (2). In the first the top of the pli is directed medially in the second laterally. These two plis de passage continue caudally in one, forming in this way a three-rayed figure.

As to the origin of the first pli de passage, ZUCKERKANDL demonstrates in first instance on page 293, that the first pli de passage can be composed by two pieces; in other words it is a body, which only afterwards develops into one and therefore the union of the parietal and occipital part of the brainsurface is not primarily, but secondarily on that spot.

On page 296 his view is worked out further. The second pli de passage of GRATIOLET should form the real primary union and should run in oblique direction from the gyrus angularis towards the top of the operculum parietale.

¹⁾ ZUCKERKANDL E., "Zur Morphologie des Affengehirnes" Zeitschr. f. Morph. u. Anthr. 1903.

In the further development there should originate out of this part lying at the back, out of its upper portion, an outgrowth, directed frontalwards, which grows towards the back ridge of the upper parietal-convolution. This frontalwärts growing piece will come in contact with a part of the upper parietal convolution, which is growing backwards, therefore towards the occipital pole. When a union is accomplished by these two parts which are growing towards each other and which belong respectively to the lobus parietalis and occipitalis, then the 1st pli de passage is formed.

As the above said shows the way in which ZUCKERKANDL thinks the origin of the 1st pli de passage to be, yet on the other hand he joins the other investigators, who are of opinion that the 1st and 2nd lateral pli de passage are lying primarily in the depth and only secondarily come to the surface. Thus he writes on page 289, on which he divides the 1st pli de passage into three forms: "Bei der dritten Form ist die Uebergangswindung wie bei den Anthropoiden an die Oberfläche der convexen Hemisphärenfläche getreten".

From this it is distinctly proved that he assumes that these plis de passage ought to be lying in the depth, but in a few cases can come to the surface.

It is to the merit of KOHLBRUGGE, who first distinctly announced the probability, that the conception prevailing up to the present day was wrong.

On p. 242 he writes: "Ich nehme an, dass die Uebergangswindung bei allen Affenembryonen erst oberflächlich liegt, etwa wie die Insula Reilii (bei Embryonen) und erst später durch Entwicklung der angrenzenden Teile in die Tiefe versenkt wird".

His communication did not receive the attention which it deserved.

The cause of this has to be looked for in different directions.

In first instance, the view of the plis de passage which primarily are lying on the surface, is totally in contradiction with what was accepted till now. The hypothesis of ZUCKERKANDL, which I previously described in short, and which appeared in the same year as the communication of KOHLBRUGGE, points to it.

As the latter moreover only possessed full-termed material, he could not deliver the *evidence* to his conception.

These two facts in themselves made already improbable that much attention should be drawn to his communication.

Add to it moreover, that he does not always consistently work out his view, as he e.g. writes on page 220: "CUNNINGHAM hat die

Uebergangswindung sogar bei *Cebus* hervortreten sehen. Ich konnte gleiches bei einem *Papio porcarius* constatieren".

From this one may conclude that KOHLBRUGGE too has seen a convolution "hervortreten" and this naturally was not his intention to write.

His comparison too, of the ape-fissure with the insula Reilii was not a lucky one. We know to be sure (EDINGER p. 47) that the latter is that part of the developing pallium, which is placed on the corpus striatum. By the strong union between these two, it remains backwards in growth and causes in this manner the sinking down of it. As however such a relation does not exist on the lateral surface of the occipital brain, his example of comparison was not happily chosen.

Notwithstanding all this, it is to the credit of KOHLBRUGGE that he has come to the conclusion (without the service of embryonal material), that the plis de passage primarily ought to have been on the brainsurface.

I already wrote that the view of KOHLBRUGGE was left unnoticed by the investigators, which e.g. is most strongly proved by a communication of v. VALKENBURG¹⁾ published much later, where he writes on page 1042 "because part of the transition-convolutions (the first) has become superficial" ... Further on "If now moreover the 2nd and 3rd transition convolutions become superficial i. e. if they pass from the bottom of the monkey-slit to the surface of the lob. parietalis" ...

By these views of v. VALKENBURG it is most convincingly proved, that the general opinion is still that the plis de passage are lying primarily in the depth and only secondarily come to the surface.

Turning to the embryonal material, which I gathered and often referring to my previous communication concerning the origin of the convolutions at the place where the ape-fissure is going to be formed, we see there that up to an embryo of 172 grams, there is no question of an apefissure, but that all the important sulci on the brain surface have already been formed (fig. 2).



(Fig. 2).

$l + e =$ s. inter parietalis.
 $m + m' =$ s. parieto. occipit. lat.
 $w =$ incisura sulc. par. occ. med.
 $b =$ s. occip. temp. later. seu
 , occip. inf.

¹⁾ VAN VALKENBURG, C. T., On the occurrence of a monkey-slit in man". Royal Academy of Science. Amsterdam 1913.

Now we know that the lobi parietalis and occipitalis are separated, on the surface of the hemisphere by the s. par. occ. lat. ($m + m'$) and on the medial surface by the s. par. occ. med. (w), while the lateral border is formed by the s. occip. inf. (b).

Before the formation of the apessure there are between these sulci bridging convolutions which pass from the one lobus to the other.

The first communication comes from the arcus parieto-occipitalis along the medial end of the m' and continues in this way on the occipital surface (on fig. 2 this communication first goes between $l + e$ and w , and later medially from m' . On fig. 3 it is indicated by the arrow sub I. One sees it deviating occipitalwards to the lateral and medial surface).

The second communication comes from the gyrus angularis (fig. 3 sub 2) and from the gyrus temporalis II (fig. 3 sub 3), to pass as a single convolution between the sulcus occ. inf. and the lateral part of the sulc. par. occ. lat. (m), towards the lobus occipitalis.

The third communication is found on the medial surface, beneath the sulcus par. occ. medialis. It is the gyrus cuneus of ECKER, which

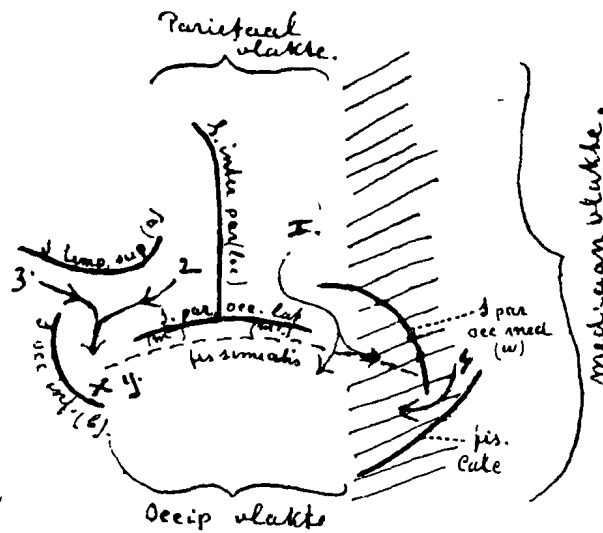

vlakte = surface

Fig. 3.

here connects the praecuneus with the cuneus. The arrow sub 1 indicates on fig. 3 the direction of the communication.

In semnopithecii one therefore finds three *bridging convolutions* lying on the surface, between the parietal and temporal part on the one side and the lobus occipitalis on the other side. *These three communications are the plis de passage.*

In my former publication I made clear, that when in *semnopithecus* the ape-fissure is being formed, (result of the overgrowth of the occipital part), the line of curvature begins either caudal or nasal of the $m + m'$. In the schematic drawing (fig. 3), I granted, that this line of curvature (see dotted line) is lying caudal of the $m + m'$, and therefore when the ape-fissure is later being formed, the three $l + e$, $m + m'$ and w have to be found on the frontal face of it.

As the ape-fissure generally extends from a point on the lateral surface, mostly medially from b , (s. occ. inf.) and from there over the ridge of the mantle towards the medial face and there is united with the ventral part of w (s. par. occ. med.), the following will happen with the three plis de passage (see dotted line fig. 3).

The "lateral" on fig. 3 indicated by the arrows 2 and 3, will disappear for a part e.g. y in the ape-fissure. The part x however will remain on the surface. Only in case the ape-fissure is extended unto the b sulcus, then too the part x will disappear in the depth. Such a case ZUCKERKANDL describes on page 286 in *cynocephalus marmon* and *cercopithecus patas*.

The "intermedial" communication, indicated on fig. 3 by the arrow 1 will disappear partly or wholly in the depth.

The "medial" pli de passage, indicated on fig. 3 by the arrow 4 will never disappear in the depth, because till now, as to my knowledge, no ape-fissures have been described, which pass on to the fissura calcarina.

The above mentioned, which is a logical result of what the development of the ape-fissure teaches us, is not in accordance with the conception of GRATIOLET and others, that the number of the plis de passage should be six and of these 4 on the lateral and 2 on the medial face.

The cause of the difference of opinion has to be looked for in the starting-point of the investigation.

I from my point of view, believe that in this case should prevail what embryology teaches us, while GRATIOLET started from that which he found in adult specimens.

Now it is comprehensible that when an ape-fissure is going to be formed and during this process the fore part is pushed downwards, this cannot always happen equally regularly. Therefore it is natural, that after opening the ape-fissure not always the same aspect will be shown to us. During the downwards pushing there will be formed curves, plis and sulci, which will not always obtain the same form. The sooner this will not be the case where the influence

is not always felt in the same way. E.g. I already pointed out that the centre of overgrowth can be lying more to the front or more to the back, and also more medially or more laterally. Moreover there will be still other influences, unknown to us. Result of this is that although in general the same aspect may be rather regularly found, yet this is not the case with the subdivisions.

Accepting this, the drawing, which shows the depth of the ape-fissure after resecting of the operculum, can differ within certain limits.

Now, when one exclusively derives from what the ape-fissure in adult animals shows, then one will be inclined as it were to value highly those curves and sulci, which are only secondarily formed.

If we on the other hand keep to the aspect that embrology shows to us, then the process becomes much simpler and more comprehensible.

If we keep to the latter, which seems rational to me, then one can speak in *Semnopithec*i and from analogy in all related monkeys, only of the three plis de passages as I described them.

Now the six plis de passages, described by GRATIOLET are derived from the three which I described and therefore they have many mutual characters.

Thus GRATIOLET describes three plis de passage between the *b*-sulcus (s. occ. inf.) and the lateral part of *m* (s. par. occ. lat.). See fig. 3, the arrows 2 and 3. In reality one only knows my "lateral" pli de passage, of which a larger or smaller part is pushed into the ape-fissure.

The 2nd + 3rd + 4th plis de passage of GRATIOLET agree with the "lateral" pli de passage as I described it.

GRATIOLET moreover knows a first-outer and an upper-inner pli de passage, which at a point run into one.

From the figures 2, and 3 sub I it is to be seen, that at that point there is but one bridging convolution, which goes along the arcus par. occ. to the back of the brain. If an ape fissure should be formed, then this part in general is pushed for a smaller or larger portion in the depth.

The 1st lateral and the upper medial plis de passage of GRATIOLET form therefore together the "intermedial" pli de passage, according to my description.

The lower-median pli de passage of GRATIOLET, the gyrus of ECKER, which forms the communication between cuneus and praecuneus, appears in fig. 3 above the fissure calcarina (sub 4). This medial pli de passage remains also in the new classification

unaltered. As the ape fissure, to my knowledge, never continues until the *fissura calcarina*, this pli de passage always remains on the surface.

As the above-mentioned brings about an important change in our conception concerning the plis de passage it is desirable, that the names keep count with it.

1. In relation to the localisation I therefore propose to call the pli de passage, which lies between the s. occ. inf. (*b*) and the lateral part of *m* (s. par. occ. lat.) on fig. 3, indicated sub 2 and 3: the *gyrus annectens lateralis*. This thus agrees with the 2nd, 3rd and 4th pli de passage of GRATIOLET.

2. We shall call the communication between lobus parietalis and occipitalis on fig. 3, indicated sub 1: the *gyrus annectens interpositus*. Thus it is found between the lateral and medial one and agrees with those two which were put down as the 1st lateral and upper-medial ones of GRATIOLET.

It will be superfluous to call special attention to the fact, that there where this bridging convolution already exists before the ape fissure is formed and commences as a whole, that there the hypothesis of ZUCKERKANDL, which I already in short referred to and according to which it should be formed out of two portions, is wrong.

3. We shall call the communication between cuneus and prae-cuneus (fig. 3 sub 4) the *gyrus annectens medialis*. This agrees therefore with the lower inner pli de passage of GRATIOLET.

The question as to the relation of the plis de passage in other monkeys now arises.

In my former report I pointed out that the place where the ape fissure is being formed, can be totally different in different monkey-species.

Thus it is known that in some of the platyrrhines, e. g. ateles, the sulcus interparietalis (*l + e*) although ending in a T-piece, in the same way therefore as in the semnopithecii, ending in the *m + m'* sulcus (fig. 2), possesses an ape-fissure, which is lying caudally from it. The *m + m'* sulcus is thus not pushed down in the ape fissure. Now if we accept this *m + m'* sulcus (s. par. occ. lat.) to form the border between the lobi parietalis and occipitalis, then follows, that the ape fissure in these monkeys is formed on the occipital face.

If we keep to the conception, that the plis de passage, as it is in semnopithecii, macaci etc., form the communication between subdivisions of the brain, differing from each other (e. g. parietal and occipital, or temporal and occipital) then, in case the ape fissure is

formed *totally on the occipital surface*, naturally there is not one single pli de passage pushed down in the depth. These remain in front of the ape fissure on the surface.

In ateles and related monkeys therefore all the plis de passage are lying on the surface.

But when the fissura sismalis becomes but deep enough, then there will be such important contorsion of the brainsurface which is pushed down, that the conformity with plis de passage, superficially examined, becomes very great. If one however observes the origin of these plis, and curves, then they appear to have been formed out of a former smooth brainsurface. These therefore are not real plis de passage.

Again different is the relation in the anthropoids.

That in the latter it entirely changes, one learns from the report of BOLK¹⁾ of two gorillabrain.

On his figures 4(a) and 7(b) the sulcus interparietalis ($l + e$) proves to end in the ape fissure. On fig 4 the ape fissure continues over the edge of the brainmantle on the medial surface. On the right hemisphere (p. 205, fig. 18) the ape fissure does not come in connection with the *w* sulcus (par. occ. med.). This happens however on the left brainhalf (p. 220, fig. 24). On fig. 7 again it is different: there the ape fissure on the left side only comes to the edge of the brainmantle, on the right it does not even reach the latter.

As from the above mentioned the incisura parieto-occ. med. proves not once to have penetrated into the depth, it follows without more that the interposed pli de passage (gyr. annectens interpositus mihi, or 1st lateral pli de passage of GRATIOLLET) has only disappeared for a small part in the ape fissure.

This agrees on the whole with the researches of others on gorillabrain, which had as result that the interposed pli de passage totally remains on the surface.

Although this last does not quite agree with the researches of BOLK, yet they agree that the ape fissure in anthropoids, as to the medial part, is not by far so well developed as in the semnopithecii.

As to the lateral pli de passage (gyrus annectens lateralis) this remains in gorillas related in the same way as in semnopithecii and macaci. It is found therefore between the *m* and *b* sulcus and a smaller or larger part of it will be pushed down in the depth.

An exception to this is given by the view which BOLK shows us on fig. 8, p 153. By the strong development of the back branch (α^3 of

¹⁾ BOLK, L. Beitrage zur Affenanatomie. — Das Gehirn von Gorilla. — Zeitschr. f. Morph. u. Anthr. 1909.

KUKENTHAL and ZIEHEN) of the sulcus temporalis superior, the latter has not only pushed down the *b* sulcus, but it too has divided the lateral pli de passage as it were into two portions. In this drawing one could speak of two lateral plis de passage, which therefore run towards the occipital surface. But as this example is an exception, it cannot be counted of much worth. Yet it proves that where in the higher development the complex of sulci becomes more complicated, it can be of influence on the image of the plis de passage. The embryonal material could show us the way in this case.

From what is found in anthropoids follows that the ape-fissure on the whole is less developed than in semnopithecids and related monkeys. It gives the impression as if the sulcus begins to contract.

CONCLUSIONS.

1. The plis de passage in foetal life are lying on the surface.
2. They form, lying on the surface, the communication between the lobi parietalis and temporalis with the lobus occipitalis.
3. In semnopithecids, macacids and related monkeys only three plis de passage are known
 - a. gyrus annectens lateralis, lying between the *m* and *b* sulcus.
 - b. gyrus annectens interpositus, lying on the mantle surface, forming the continuation of the arcus parieto-occipitalis.
 - c. gyrus annectens medialis, forming the communication between the cuneus and praecuneus, lying above of the fissura calcarina.
4. When the ape-fissure is formed on the border of the parietal and occipital part (semnopithecus, macacus etc.), then the lateral and interposed-gyrus annect. are pushed totally or partially in the depth.
5. When the ape-fissure is formed on the occipital surface (ateles, nycticebeus tardigradus etc.), then it does not come in contact with the plis de passage and these therefore remain on the surface.
6. In the anthropoids the ape-fissure is considerably less developed than in semnopithecids etc.

Physiology. — “Quantitative determination of slight quantities of SO_4 . II. Contribution to macrometrical analysis”¹⁾. By Prof. H. J. HAMBURGER.

(Communicated in the meeting of April 28, 1916).

1. Introduction.

Repeatedly physiologists and clinicians find themselves confronted by the task of determining quantitatively very slight quantities of some substance and if no good titration method is available, the

¹⁾ A more detailed account will be given in “Biochemische Zeitschrift” 1916.

solution of the problem becomes practically impossible, at least when for instance daily, series of determinations have to be made. Chemists often experience these difficulties no less. This will be the reason why a quantitative micro-analysis begins to develop itself, to which all the principles of the macro-analysis are applied, but with miniature implements, the micro-scales of *Nernst* are then mostly used as a weighing-apparatus.

This method, however, has its drawbacks in being an analysis by weight, with all the difficulties attending it, which difficulties are still increased by the fact that a slight mistake materially affects the results. Besides, the accuracy of the macro-gravimetric method is anything but perfect. All this applies for instance to the quantitative determination of the potassium and that of the SO_4 . It need not surprise us, therefore, that our knowledge of the K- and SO_4 - economy leaves much to be desired.

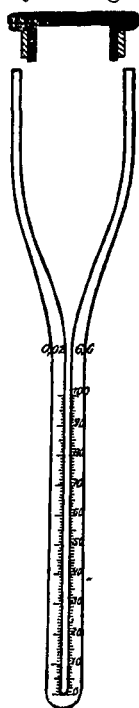

As regards these two substances, however, I have succeeded in finding another method, which consists in the volume of the precipitate being determined instead of the weight; this is done in a glass apparatus, the top part of which is funnelshaped, the neck being a calibrated capillary tube (see fig. 1). I might call the instrument a *chonohaematocrite*¹⁾. The calibrated capillary part has a content of 0.04 cub. centimetres, and is divided into 100 equal parts. The column of the precipitate is read off after being centrifugated to constant volume.

This method combines accuracy with a simplicity hitherto unattained in the determination both of potassium and of SO_4 . The potassium method, I applied, has been described already²⁾, it was lately used by me to solve physiological problems which could not be settled by the available methods³⁾. I shall not dwell upon this potassium-method. It need only be stated that to the fluid containing the potassium-salt, a solution of sodium-

¹⁾ From $\chi\acute{o}\nu\eta$ (funnel) and haematocrite or blood-investigator, the name formerly given by *Hedin* to a calibrated capillary tube, which he used to determine the volume of the red blood-corpuscles in blood.

²⁾ HAMBURGER. *Biochemische Zeitschrift* **71** (1915) 415. *Recueil des Travaux chimiques des Pays Bas et de la Belgique*. T. **35**. (1916), 225.

³⁾ HAMBURGER, Die Permeabilität von unter physiologischen Verhältnissen kreisenden Blutkörperchen für Kalium, nach einer neuen Methode untersucht. (Zusatz geringer Mengen von CO_2 , Glukose, NaCl, KCl, NaOH und KOH). *Wiener Med. Wochenschrift* 1916 No. 14—15; Festnummer für Prof. S. EXNER.

cobaltidnitrite is added and all the potassium is precipitated as potassiumsodiumcobaltidnitrite, which with GILBERT we call cobalt-yellow. As we said, the precipitate is centrifugated until the volume remains constant and then read off. When the volume of cobalt-yellow supplied by a known K-solution has been determined, the amount of the unknown K-solution can be found. The imperative condition is satisfied that there should be a proportionality between the volume of cobalt-yellow and the amount of K, and that the result is also found to be independent of the rapidity of centrifugation.

2. *Difficulties in the quantitative determination of SO₄.*

The fact that SO₄ is precipitated by BaCl₂ is known to every one who has studied chemistry for half a year. The reaction is a classical instance of precipitate-formation. After the experiences met with in the case of K, it would be expected that slight volumes of SO₄ in a solution containing a sulphate, could be determined volumetrically without much difficulty by simply measuring the volume of the resulting BaSO₄. The results of the experiments, however, were entirely unsatisfactory. The volume was found to be influenced by: the temperature, the volume of the fluid, the amount of the excess of BaCl₂, the quantity of HCl and the presence of numerous substances which are met with in the sulphate-solution, nay even the manner in which the reagent was added.

What the literature taught me on the determinations of SO₄ by weight-analysis was far from encouraging. It is evidently among the worst that exists. When we read TREADWELL's book on quantitative analysis 4th Ed. (1907) p. 353, then it appears what great obstacles the usual gravimetric method encounters, even when BaCl₂ is added to H₂SO₄ the weight of the precipitate is not always the same. BaCl₂ is closed in, and that in amounts which depend for instance on the manner in which the BaCl₂ is added, by drops or at once. If we have to deal with a sulphate containing other salts, the matter becomes more complicated still. Besides the BaCl₂ being closed in, other salts are adsorbed; especially iron and calcium-salts are weighed with the precipitate, even after the BaSO₄ has been carefully washed. The quantity of HCl added is by no means immaterial, nor the dilution with water, which makes itself the more felt in proportion as the crystals are smaller.

A few years ago the matter was taken up again by M. J. VAN 'T KRUY'S¹⁾, who submitted it to a detailed systematic investigation; he

¹⁾ M. J. VAN 'T KRUY'S. Zeitschrift für anal. Chemie, 49 (1910), 393.

tried to arrive at the conditions under which the quantitative determination of SO_4 gives the most reliable results. "Wie einfach eine Bariumsulfatbestimmung auch scheint, so zeigt sich doch, dass in Wirklichkeit die Ausföhrung derselben um mehrere Ungenauigkeiten behaftet ist, die sogar trotz aller möglichen Vorsicht gewöhnlich nicht vermieden werden können," and then he gives a method which is rather complicated. Especially the presence of Calcium is objectionable.

After these remarks it will not surprise us that the physiology and the pathology of the sulphur-economy have been little studied until now, especially if we consider that, except in urine the quantity of SO_4 in bodyfluids is exceedingly small.

Therefore it was attempted to establish a microvolumetrical method for SO_4 in the same way as it had been done for K. - To known solutions of Na_2SO_4 , HCl and BaCl_2 were added, both in known concentrations. Then it was determined:

1. Whether, if the circumstances were the same, the same volume of precipitate was obtained.
2. Whether the volume of the precipitate is influenced by:
 - a. dilution of the fluid with water.
 - b. the concentration of HCl .
 - c. the quantity of BaCl_2 solution added.
 - d. the presence of other mineral substances which may be met with in animal fluids, such as NaCl , KCl , Ca , Mg , and phosphates.

It soon appeared that these factors strongly influenced the volume of the precipitate.

Mindful of what our K determinations had brought to light, we asked ourselves whether these unsatisfactory results were connected with or due to, the nature of the crystalline precipitate. Again we called in the help of the microscope. It was indeed discovered that whenever we started from the same volume of SO_4 and yet different volumes of BaSO_4 were arrived at, this was always attended with another microscopic view of the precipitate. Now there were needles, now columns, sometimes they presented an appearance of crosses; but not only the shape differed, considerable differences in size were also manifest. And all this at the same temperature. Hence it was advisable to find the conditions under which the crystals always had the same size and shape.

The investigations connected with the K determination had shown that in order to obtain useful results the crystals ought at any rate to be very fine. Here again it was attempted to satisfy this demand. *An addition of some acetone was one of the chief means by which this result was attained.*

It would be of little use here to give an account of the many difficulties experienced in this investigation.

Let us, therefore, relate the *modus operandi* which has given results that were under all circumstances satisfactory, that is to say by which we obtained 1. invariably the same volume of precipitate from the same quantity of SO_4 , 2. n -times a volume of precipitate from n -times a quantity of SO_4 , 3. a volume of the precipitate entirely independent of the presence of mineral substances met with in biological fluids.

3. *Method to be followed in the microvolumetrical determination of SO_4 .*

5 cc. of the fluid containing sulphate are mixed with $2\frac{1}{2}$ cc. of concentrated HCl 1:1; to this mixture are added 5 cc. of a BaCl_2 2 aq. sol. of 2.44%, in which 3 to 5 drops of acetone have been added.

Sulphate and reagent are mixed at room-temperature. The manner, however, in which the BaCl_2 is added to the HCl-sulphate solution is of the greatest importance if we wish to obtain satisfactory results. If this is lost sight of, if it is added quickly in one case and slowly in another, the two parallel-experiments may give entirely different results, and the microscopic investigation shows accordingly that the crystalline precipitate is not the same in these two instances. It seemed to me that this must be explained as follows: If the BaCl_2 -sol is added slowly, there will still be free SO_4 in the fluid at first. Now if we go on adding, the amount of dissolved SO_4 decreases; hence the proportion between the reagent and the SO_4 which has not been precipitated, is continually modified during the addition. Since the quantity of acetone materially affects the shape and size of the crystals most likely owing to its effect on the surface-tension, the way in which the BaCl_2 -sol. with the acetone are added, will likewise affect the volume of the precipitate. So important a part is played by the manner of adding that if in two parallel-experiments the BaCl_2 -solutions containing acetone, are seemingly added in the same way and immediately shaken, the volumes of the precipitate may still be different. In order to effect a rapid and perfect mixture we proceeded as follows:

In a tube of thick glass a narrower one is placed having a content of about $5\frac{1}{2}$ cc. (see fig. 2). On the outside of this narrow tube a glass column has been melted reaching to the cork which may shut off the wide glass tube. Into the space between the narrow

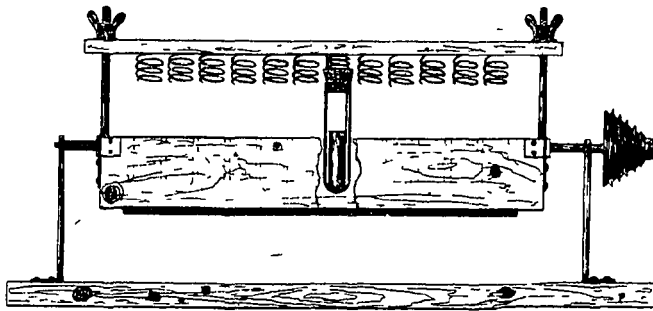

Fig. 2.

$\frac{1}{2}$ of actual size.

and the wide tube we bring $7\frac{1}{2}$ cc. of the hydrochloric sulphate solution. It does not reach the upper rim of the inner tube. Then the 5 cc. BaCl_2 -solution are brought into the inner tube by means of a pipette, mixed with 5 drops of acetone and the wide tube is closed with a stopper. This stopper is pushed in so far that the narrow tube is gently pressed against the bottom. Then this tube is placed in a frame which can be turned on an axis. This frame can hold twelve such tubes. When the frame is turned round the reagent suddenly bursts into the sulphate-solution so that in an extremely short space of time a perfect mixture is obtained. To make quite sure the frame is turned a few times. Experience teaches that thus a very fine precipitate is formed, the particles measuring on an average 0.0026 millimetres. The crystal shape at the usual magnitude (Leitz obj. 8, or 2) cannot be distinctly recognized; they are not needles, columns or crosses; to an untrained eye they suggest cubes that are not clearly cut.

The drawing shows that the apparatus can also be turned mechanically, for instance by an electromotor. The rotation may also be brought about by substituting for the disc an iron bar

Fig. 3. $\frac{1}{4}$ of the actual size.

perpendicular on the axis. A solid brass cylinder can be moved along the iron bar and fastened with a screw. It depends on the place of this cylinder how rapidly the frame with its tubes will turn round when it is loosened (Cf. the article in the "Biochemische Zeitschrift" 1916).

When the precipitate has been formed it can immediately be transferred to the chonohaematocrite. Therefore the small tube is taken out of the larger one and the latter is centrifugated for a short time, so that all the precipitate in it, is found on the bottom. Now that which is still found in the small tube must be removed

to the large one. To bring this about some of the clear fluid in the latter is taken into a pipette and all the precipitate in the small tube is washed into the large one. In the same manner the surface of the small tube is washed, so that all the BaSO_4 gets into the large tube.

We might wish to bring the contents of this tube ($12\frac{1}{2}$ cc.) into the funnelshaped part of the chonohaematocrite, but the latter holds only about $2\frac{1}{2}$ cc. Therefore we centrifugate; the greater part of the clear fluid is removed and the sediment is mixed with the rest of the fluid. After the capillary tube has been filled with mother liquor by means of a glass tube drawn out into a capillary, this turbid mass is brought into the funnel-shaped part. We now centrifugate, the clear fluid is removed from the funnel-shaped part and replaced by the BaSO_4 which had remained behind in the wide tube. It need hardly be said of course that the BaSO_4 adhering to the inner and outer surface of the small tube must be transferred to the wide tube by being washed with mother liquor. Now the whole is centrifugated until the volume remains the same, which takes about half an hour¹⁾.

We will now state the results of some experiments with some pure Na_2SO_4 solutions. They are all double-experiments.

4. *Results of some microvolumetrical SO_4 -determinations.*

TABLE I.
Proportionality between the volume of BaSO_4 precipitate and the SO_4 used.

7.5 cc. of HCl sulphate-solution +5 cc. of BaCl_2 -solution containing acetone.	Number of divisions of BaSO_4		
	average		calculated III
	I	II	
1) 2 cc. of Na_2SO_4 10 aq. 2% + $2\frac{1}{2}$ cc. of HCl 1:1 + 3 cc. of water	41	} 41	
2) 2 " " + $2\frac{1}{2}$ " + 3 "	41		
3) 3 " " + $2\frac{1}{2}$ " + 2 "	63	} 62	$\frac{3}{2} \times 41 = 61.5$
4) 3 " " + $2\frac{1}{2}$ " + 2 "	61.2		
5) 4 " " + $2\frac{1}{2}$ " + 1 "	82	} 82	$\frac{4}{2} \times 41 = 82$
6) 4 " " + $2\frac{1}{2}$ " + 1 "	?		
7) 5 " " + $2\frac{1}{2}$ " "	103	} 102.5	$\frac{5}{2} \times 41 = 102.5$
8) 5 " " + $2\frac{1}{2}$ " "	102.5		

¹⁾ Compare the article: Une méthode simple pour le dosage de minimes quantités de potassium. Recueil des Travaux Chimiques des Pays-Bas et de la Belgique. Tome XXXV 1916, 225.

This table shows.

1. that the results of each pair of experiments agree satisfactorily (see column I).

2. that the volumes of the precipitates vary as the quantities SO_4 used (cf. columns II and III).

We will now consider to what extent an addition of NaCl influences the volume.

TABLE II.
Effect of NaCl on the volume of the $BaSO_4$ precipitate.

7.5 cc. of HCl sulphate solution + 5 cc. of $BaCl_2$ sol containing acetone.							Number of divi- sions of $BaSO_4$		
1)	2cc. Na_2SO_4	10 aq. 4%	+ 2½ cc. of HCl 1:1	+ 0,2 cc. of NaCl 9%	+ 2,8 cc. of H_2O		82		
2)	2	"	+ 2½	"	+ 0,2	"	+ 2,8	"	81.5
3)	2	"	+ 2½	"	+ 0,4	"	+ 2,6	"	81
4)	2	"	+ 2½	"	+ 0,4	"	+ 2,6	"	81
5)	2	"	+ 2½	"	+ 0,6	"	+ 2,4	"	81.5
6)	2	"	+ 2½	"	+ 0,6	"	+ 2,4	"	81.5
7)	2	"	+ 2½	"	+ 0,8	"	+ 2,2	"	81.5
8)	2	"	+ 2½	"	+ 0,8	"	+ 2,2	"	80.5
9)	2	"	+ 2½	"	+ 1	"	+ 2	"	80.5
10)	2	"	+ 2½	"	+ 1	"	+ 2	"	81

TABLE III.
Effect of Na_2HPO_4 12 aq. on the volume of the $BaSO_4$ precipitate.

7.5 cc. of HCl sulphate solution + 5 cc. of the $BaCl_2$ sol. containing acetone.							Number of divi- sions of $BaSO_4$		
1)	2cc. of Na_2SO_4	10 aq. 4%	+ 2½ cc. of HCl 1:1	+ 0,2 cc. of Na_2HPO_4 9%	+ 2,8 cc. of H_2O		82 1)		
2)	2	"	+ 2½	"	+ 0,2	"	+ 2,8	"	82 1)
3)	2	"	+ 2½	"	+ 0,4	"	+ 2,6	"	81
4)	2	"	+ 2½	"	+ 0,4	"	+ 2,6	"	82 1)
5)	2	"	+ 2½	"	+ 0,6	"	+ 2,4	"	82 1)
6)	2	"	+ 2½	"	+ 0,6	"	+ 2,4	"	81.5
7)	2	"	+ 2½	"	+ 1	"	+ 2	"	80.5
8)	2	"	+ 2½	"	+ 1	"	+ 2	"	80.5

1) The caoutchouc stoppers had let loose some small particles, which mixed with the white precipitate.

Evidently the NaCl has not affected the volume of BaSO₄.

A similar result was obtained when Na₂HPO₄ 12 aq. was added, (See table III p. 122).

Where the precipitate has not been polluted, *the volume of BaSO₄ has obviously not been modified by the phosphate.*

Finally an experiment to investigate the influence of the salts met with in animal substances.

TABLE IV.

Effect of a mixture of K, Na, Mg, Cl and Na₂HPO₄ on the volume of the precipitate.

7,5 cc. of HCl sulphate solution + 5 cc. of BaCl ₂ solution containing acetone.	Divisions of BaSO ₄
1) 2 cc. of Na ₂ SO ₄ 4 ⁰ / ₀ + 2 ¹ / ₂ cc. of HCl 1:1 + 3 cc. of H ₂ O	81.5
2) 2 " + 2 ¹ / ₂ " + 3 "	80.5
3) 2 cc. of Na ₂ SO ₄ 4 ⁰ / ₀ + 2 ¹ / ₂ cc. of HCl 1:1 + 1,2 cc. of KCl 3,6 ⁰ / ₀ + 0,8 cc. of NaCl 9 ⁰ / ₀ + 1,3 cc. Na ₂ HPO ₄ 9 ⁰ / ₀ + 0,8 cc. CaCl ₂ 3 ¹ / ₀ + 0,8 cc. MgCl ₂ 2 ⁰ / ₀ + 0,2 cc. H ₂ O	82.5 ¹⁾
4) like 3	82.5 ¹⁾

From this experiment it may be concluded that if the foregoing prescriptions (sub 3) are carried out, the volumetrical sulphate-determination gives highly satisfactory results, much more so than the gravimetric method. But we repeat on the ground of our extensive researches that the directions must be carefully attended to.

The prescriptions especially apply to the manner in which fluid and reagent are mixed. The size and shape of the crystals depend on it. Hence we are in the habit, when the mixture has taken place, of taking a drop of the turbid fluid with a capillary pipette and examine it under the microscope (Leitz obj. 8, Oc. 2). It becomes then evident at once without measurement whether the crystals are right. As we said before they suggest small cubes. Their surface must seem smooth. If the microscopic view does not satisfy this demand, if the crystals seem rough at the surface or if they have for instance double the diameter then the volume of the sediment is also found to exceed 81.5 divisions. Who has not yet seen the desired crystals may take as a criterion whether 2 c.c. Na₂SO₄ 10 aq. of 4⁰/₀ gave a volume of 81.5 divisions. Whenever this was the case, the crystals were as they should be. A preparation may be kept to serve for comparison. When kept, evaporation must of

¹⁾ The cork had lost some small particles, which polluted the column of BaSO₄.

course be prevented; for this purpose the preparation may be surrounded with a frame of soluble glass or paraffin wax as is usually done in histological technics.

5. *Some general observations.*

In chemical work other metals and acids than those we added will be met with in the fluid containing the sulphate. It will have to be determined by an intentional addition of these substances in what degree they influence the volume of the precipitate. These researches fall outside the scope of this paper. But it remains to be settled to what extent the noxious influence of proteid can be neutralized. Experience has taught us that this can be easily done by ultrafiltration. A filter, drenched with a 5% sol. of celloidin in alcohol and ether and subsequently treated with water easily keeps back the proteid.

As regards the *degree of accuracy of our method* we may give the following calculation: 2 c.c. of Na_2SO_4 10 aq. 4% contain 0.02386 grammes of SO_4 . The volume of BaSO_4 gives by these averages 81.5 divisions. *Each division* of our tube corresponds, therefore, to $\frac{0.02386}{81.5} = 0.000294$ grammes of SO_4 . Since in accurate work no greater mistake is made than one division, the method is *accurate to 0.000294 grammes of SO_4 .*

The object of this paper is twofold. First it intends to supply a simple method enabling us to make in an easy manner highly accurate determinations of very slight quantities of SO_4 . Secondly it aims at giving an impulse to the further development of a new method of quantitative analysis, which certainly deserves to rank with both the micro- and macro-gravimetric method, because it is simple and accurate, saves time, allows us to work with slight quantities, and is moreover particularly adapted to series of determinations. These qualities lately became manifest at the determination of potassium, and some years ago in the study of an equilibrium reaction¹⁾. The great obstacles to be encountered will especially consist in the difficulty to discover the conditions under which a precipitate is obtained giving at all times the same microscopic view. At the present moment this can be effected only empirically; indeed, as far as I am aware, next to nothing is known of the forces which underlie the varieties of crystal shape and crystal size of the same

¹⁾ HAMBURGER and ARRHENIUS. On the nature of precipitin-reaction. These Proceedings, meeting of May 26th 1906.

substance. Also from a physico-chemical point of view it will be desirable to start researches on this subject.

S U M M A R Y.

It was set forth that it is of importance:

1. To possess by the side of the macro- and microgravimetric analysis, another method which enables us to make quantitative determinations of very slight quantities of a substance in a simpler and more accurate way.

2. The method detailed here is based on the principle that after the reagent has been added, the precipitate formed is centrifugated in a calibrated capillary tube until the volume remains constant and can be read off. When the volume of BaSO_4 corresponding to a SO_4 -sol. of a known concentration has been determined, then it is possible to determine by means of this result the SO_4 -concentration of an unknown sulphate-solution.

3. In order to make a quantitative determination of SO_4 we always add $2\frac{1}{2}$ cc of HCl 1:1 (concentrated NCl diluted with an equal volume of water) to 5 cc of the SO_4 fluid, and to this mixture 5 cc of a BaCl_2 2 aq-solution of 2.44%, containing 3 to 5 drops of acetone. The precipitate formed is centrifugated until the volume remains the same.

Whether the 5 cc of fluid contains much sulphate or only a little and whether these 5 cc of fluid contain Na , K , Ca , Mg , Cl and PO_4 makes no difference whatever, as regards the results: an n -fold quantity of SO_4 gives an n -fold volume of BaSO_4 and the presence of the above-mentioned admixtures does not affect the volume of the precipitate.

One division = 0.0004 cc. of the BaSO_4 -solution corresponds to 0.000294 grammes of SO_4 . Mistakes greater than 0.000294 grammes of SO_4 are not made if the method described sub 3 is carefully followed.

Groningen, April 1916.

*Physiological Laboratory
of the University.*

Physics. — “*Direct optical measurement of the velocity at the axis in the apparatus for FIZEAU’s experiment*”. By Prof. P. ZEEMAN.

(Communicated in the meeting of May 27, 1916).

For the comparison with theory of the *absolute* values of the shifts of the interference fringes, which I determined for light of different colours in FIZEAU’s experiment, the magnitude of the velocity

at the axis of the tubes conveying the water must be known. This velocity at the axis was deduced from the mean velocity by means of a numerical coefficient φ , which represents the ratio between the mean velocity and the velocity at the axis in a cylindrical tube for turbulent motion.¹⁾

At first I adopted for φ the value 0,84 as determined by American engineers. Afterwards I devised an optical method for measuring the mentioned coefficient. In a model of part of the apparatus for measuring FRESNEL's coefficient, the value $\varphi = 0,843$ was found. On that occasion (Communication IV) I suggested that it would be preferable, though rather difficult, to measure φ in the very apparatus used in my repetition of FIZEAU's experiment. Only lately have I succeeded in performing the necessary measurements with the original apparatus. The velocity at the axis, which is of primary importance, is now measured *directly*. The value of φ is of minor importance, but may of course be calculated from the measured mean velocity. It should be noticed that for the measurement of the total volume a verification of the water meter is necessary, so that a fault in this verification affects also φ . By the use of the method now under review one is quite independent of any verification of watermeters.

For the application of our optical method — rotating mirror; air bubbles in the running water; intense, narrow beam of light at the axis — it is necessary to have a small window in the wall of the brass tube. For this purpose an aperture of two centimeters length, one centimeter width made in the thin walled tube was closed with a cylindrical piece of glass of a mean curvature equal to that of the wall of the tube. Between the brass and the glass a thin layer of rubber was interposed to make the apparatus watertight; in order to withstand the considerable pressure the window was pressed against the tube by means of adequately constructed springs.

¹⁾ For easy references my communications relating to FIZEAU's experiment are referred to as Communications I, II, III, and IV:

I. The convection coefficient of FRESNEL for light of different colour (I). These Proceedings 17, 445, 1914.

II. The convection coefficient of FRESNEL for light of different colours (II) These Proceedings 18, 398, 1915.

III. On a possible influence of the FRESNEL coefficient on solar phenomena. These Proceedings 18, 711, 1915.

IV. An optical method for determining the ratio between the mean and axial velocities in the turbulent motion of fluids in a cylindrical tube. Contribution to the experiment of FIZEAU. These Proceedings 18, 1240, 1916.

The window was arranged for in the inferior tube of Fig. 2 B (Plate of Communication I), at the left side of the drawing near the prism and at a distance of about 36 cm. of the plane parallel plates of glass or about 25 cm. reckoned from the beginning of the moving water column.

In order to enable us to describe the results the four cocks for regulating the water supply to the tube system (see the Plate of Comm. I) are supposed to be lettered from right to left: *A, B, C, D*. When the cocks *A* and *C* were open, a determination of the velocity at the axis was made by means of the optical method, the result came out in the neighbourhood of 500 cm/sec. This is a very unexpected result, for on a former occasion (Communication II) the velocity at the axis deduced by means of the mean velocity was found 553,6 cm/sec. At first the possibility of some serious error of the optical method was thought of. The deviation was, however, entirely beyond the experimental errors. The result now obtained undoubtedly ought to be of an accuracy superior to the determination in Communication IV, for the effective distance ($l = 46$ cm.) from the axis of the tube to the rotation axis of the mirror exceeds the one formerly used ($l = 32$ cm.). After reversal of the direction of the water current (cocks *B* and *D* opened) the velocity appeared to be 580 cm/sec. This value exceeds the adopted value. These observations tended to show, first that the seemingly obvious supposition that with reversal of the water current the velocity is only changed in direction and not in magnitude was wrong and further that the velocity distribution along the axis of the FIZEAU tubes was much more complicated than supposed in the beginning. Nothing short of a measurement of the velocity at a number of points situated along the axis of the tubes became necessary. It seemed at first to suffice to investigate the distribution for only one of the tubes. In the course of the observations it became clear, however, that the measurement of the velocity at the axis had to be extended to the two tubes and to both directions of the water current.

As it was unpracticable to arrange for windows (as described above) in the brass tubes at a number of different points and as it was yet desirable to include not too few points in the survey, use was made of a PIRROT tube, *verified by the optical method*. This tube facing the current at the axis can be temporarily placed at a number of points; after removal the small aperture necessary for the adaptation of the PIRROT tube can be closed again. If a PIRROT tube is placed in a stationary current with the velocity v , we may suppose that the velocity at the aperture facing the current is zero,

and hence that $p = \frac{1}{2} \rho v^2$ or at any rate $p = \frac{k^2}{2} \rho v^2$. Here ρ represents the density of the fluid, k^2 is a constant which is, as is shown by the optical method, very nearly equal to unity ¹⁾. The pressure p may be measured independently of the static pressure in the tube, by observing the difference of pressure between that in the small Pitot tube and that in a small hole in the wall of the tube. The small hole in the wall of the tube was made in the horizontal plane passing through the aperture of the Pitot tube and at the same time in the vertical cross section through that aperture. The difference of pressure was read upon a water manometer. The pressures varied from 100 to 180 cm. of water. Part of the connexion between the hole in the wall of the tube and the manometer consists of a short length of rubber tubing, so that by means of a binding screw the variations of pressure, corresponding to variations of the velocity can be damped. The height of the manometer is a time integral ²⁾.

Fig. 1 represents to scale the two tubes with the windows V_A , V_B , V_C and indicating the points, where the small Pitot tubes were successively introduced. The apertures in the walls are not shown, the dotted lines represent the virtual ends of the *moving* fluid column, the whole length of which is 2×302 cm.



Fig. 1

The arrows indicate the direction of the current when the cocks A and C (see above) are open. The right angled totally reflecting prism is to be figured to the left, the interferometer to the right of the drawing.

The results of all the determinations of the velocity are given in the Table; the velocities are reduced to the formerly adopted mean initial pressure of $2,14 \text{ kg./cm}^2$. ³⁾

¹⁾ This point will be considered in a separate paper.

²⁾ The mean velocity at a point is defined as the mean of all the velocities to be found at that point of the tube during a certain, not too short, time interval. The component of this mean velocity in the direction of the axis determines the volume of the fluid, passing per second through a cross section. As the indications of Pitot's tube are rather insensible to changes of direction of the current it seems possible that under special conditions the apparent total flow of fluid surpasses the real flow.

³⁾ The principal cocks in the supply tubes as well as some of the places for the Pitot tubes are indicated by the same letters A , B , C , D . From the text the meaning will always be sufficiently clear.

TUBE I.

Aperture	Distance from beginning of current	v A and C open	v B and D open
A_0	9	549	509
A	24	580	530
B	54	578	510
D	100.3	590	566
C	146.6	567	581
E	219.0	536	573
F	292.2	498	568

TUBE II.

F'	292.2	567	550
E'	219.0	559	533
C'	154.8	554	540
D'	100.3	565	552
B'	57.4	520	588
A'	9	457	573

All numbers are expressed in cm.

It seems worth while to graph the results. We begin with the case that the cocks A and C are open. Fig. 2 refers to this case.

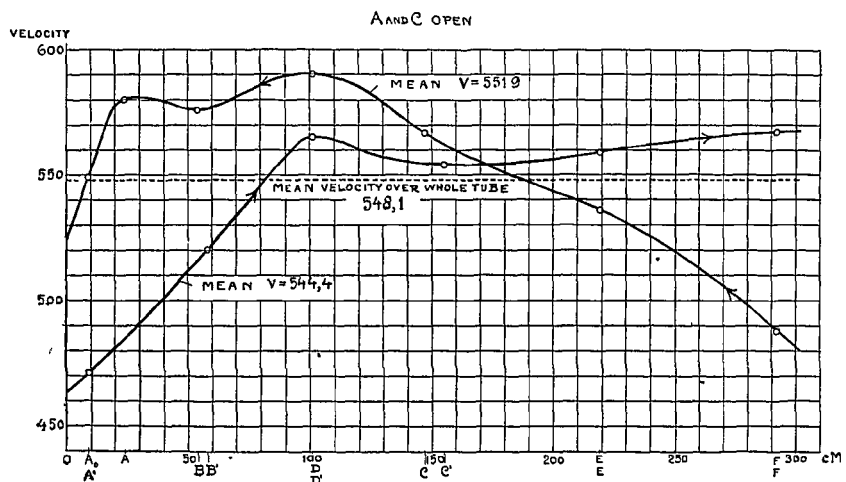

Fig. 2.

The curve with the arrows pointing to the left is travelled over first.

We now proceed to give some details as to the current *at the axis of the tube*. The velocity of the water is rather small immediately after traversing the *O*-tubes. From *F* onwards the velocity increases continuously, reaches a maximum at *D* and then decreases, after passing a smaller maximum, to about 530 cm./sec. After the passage of the horizontal *O*-tube, connecting the two tubes, the current reaches *A'* with low velocity. This increases to *D'*, decreases somewhat and again increases to *F'*. From this representation the mean velocity at the axis in the tube first traversed is 551,9 cm./sec. In the tube with the windows which is passed next, the mean velocity is 544,4 cm./sec. ¹⁾ Hence the mean velocity over the whole length of 604 cm., becomes 548,1 cm. (cocks *A* and *C* open).

If the cocks *B* and *D* are open, the water first passes by *F'*. The velocity changes as indicated in Fig. 3. Just as in the case

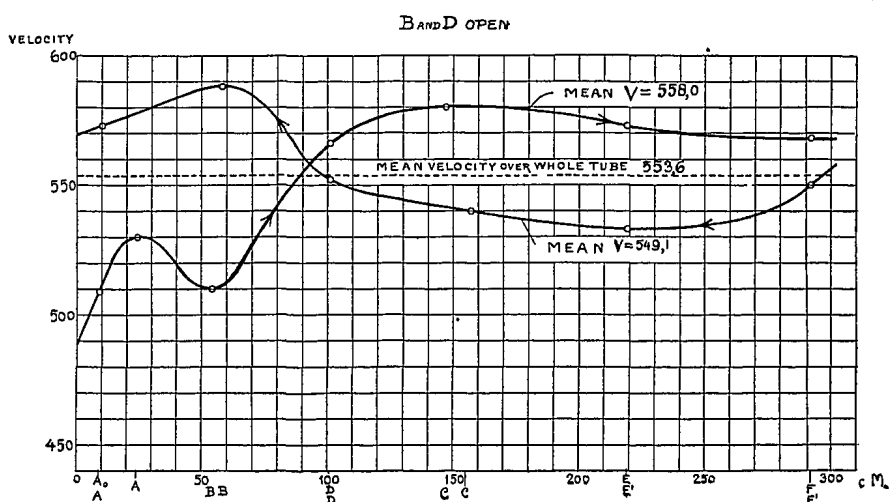

Fig. 3.

first considered the curve with arrows pointing to the left is first travelled over, but in order to apply Fig. 1 to the present case the arrows in it must of course be reversed. Near *F'* the velocity is rather great, it decreases to *E'*, increases to *B'* and again decreases, the water after traversing the horizontal *O*-tube arriving in *A*, with low velocity. After attaining to a secondary maximum in *A*, the velocity increases to *C* and then somewhat decreases. The mean velocity in

¹⁾ [It need scarcely be pointed out that the difference between these two numbers extremely probably is real.] (Note to the translation)

the tube with the windows now appears to be 549.1. In the other tube it is 558.0 cm/sec. The mean value for the whole tube becomes 553.6 (cocks *B* and *D* open). The result that in the two cases, when the cocks *A* and *C* are open, and, when the cocks *B* and *D* are open, the velocities differ, may appear less startling when it is considered that there is a small dissymmetry in the supply tubes of the apparatus and that with *A* open the water before discharge undergoes a greater change of direction than with *D* open.

A new proof for the change of velocity at the axis of the tube is given by ascertaining the *velocity distribution over the cross section* of the tube. In *A*₀ the velocity distribution is entirely different from that encountered for example in *B'*, that is to say before and after the stream traversed the horizontal part.

When the cocks *A* and *C* are open the curve traced in *A*₀ is of a parabolic character, in *B'* the central part of the curve is of smaller curvature, corresponding to a smaller velocity at the axis. The velocity distribution in a vertical line passing through *A*₀ is represented in Fig. 4. The curve is of a parabolic character, and nearly, but not quite, symmetrical.

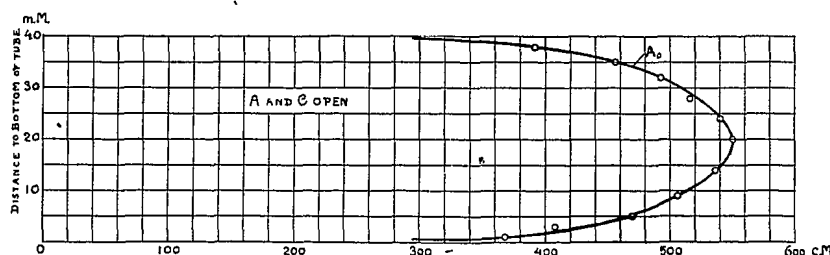

Fig. 4.

Taking the mean abscissae for points at equal distances above and below the axis and constructing a curve with these points we may determine the volume enclosed by the surface of revolution, originating when the constructed curve revolves about the axis. This enables us to determine the mean velocity, which is found to be 468 cm./sec., whereas on a former occasion (Comm. II) using the total quantity of water passing in a given time we obtained 465 cm./sec.

It is worth while to state that the distribution of velocity would according to POISEUILLE'S law give a parabola of far smaller width than the curve of Fig. 4, if the maximum velocity should be that in the figure.

9*

When the cocks *A* and *C* are open the mean velocity becomes 548.1, with *B* and *D* open 553.6. The halved sum of these numbers is 550.8. In observing the interference fringes we did not measure the displacement from a zero position, but determined the total displacement with reversal of the current, which therefore must be proportional to 550.8.

In my former paper I accepted $v_{max} = 553.6$ cm./sec. We now obtain a value for the velocity v_{max} differing only by $\frac{1}{2}$ percent from the value used in Communication II and giving excellent agreement between the experiments and the formula with the dispersion term. The difference between the two expressions under consideration amounts for the wavelength 4500 Å. U. to quite 5 percent. We therefore conclude that also as to the *absolute* phase-difference the results of Communication II remain largely in favour of the LORENTZ expression.

The comparison between theory and observation now has become very simple, v_{max} being measured directly. A separate determination of $\varphi = v/v_{max}$ is avoided. Finally however, the value of this ratio may be calculated from the results obtained at the pressure of 2.14 K.g./cm², $v_0 = 465$ and $v_{max} = 550.8$. This gives for the ratio 0.844. This mean number is not, however, a general physical constant but a constant of the apparatus. The course of the curves in Fig. 2 and Fig. 3, suggests for a long tube a final value of φ perhaps 1 or 2 percent lower than 0.844. ¹⁾

The formula for the displacement of the interference fringes must henceforth be written with a factor $\int_0^l v_{max} \cdot dl$ instead of the simple product $v_{max} \cdot l$; v_{max} being a function of the distance to the origin of the moving fluid column.

¹⁾ [Only after finishing my investigation, I became acquainted with the important memoir on fluid motion in pipes by Drs. STANTON and PANNELL. (Phil. Trans. vol. 214. 1914). From their data the often mentioned ratio appears to be 0.82 for my case. There is no conflict between the two cases, as their observations were made after the passage of a length of pipe varying from 90 to 140 diameters. This length is sufficient to enable any irregularities in the distribution of velocities to die away. In my apparatus this ideal is largely departed from. (Note to the translation).

Chemistry. — “*The Application of the Theory of Allotropy to Electromotive Equilibria*”. V ¹⁾ By Prof. A. SMITS and Dr. A. H. W. ATEN. (Communicated by Prof. J. D. VAN DER WAALS).

(Communicated at the meeting of May 27, 1916).

1. Introduction.

In our preceding communication we introduced a new view of electromotive equilibria, which is based on the assumption that the electrons in a metal phase and in the coexisting electrolyte behave as ions.

Starting from these suppositions we have discussed among other things also the potential difference metal-electrolyte, in which new relations were obtained.

In the derivation of these relations the case was supposed (first case) that the metal was built up exclusively of metal atoms, univalent metal ions and electrons. Now we will in the first place consider the case that the metal consists of atoms, v -valent metal ions and electrons, after which we shall proceed to the second case that in the metal there are present by the side of atoms and electrons, metal ions of different valency.

2. The metal consists of metal atoms, v -valent metal ions, and electrons.

The equilibrium between metal and electrolyte can now be represented by:

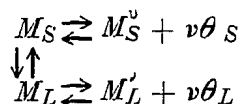

We then get the two following relations for the potential difference:

$$\Delta = - \frac{\mu_{M_S^v} - \mu_{M_L^v}}{F} \dots \dots \dots (1)$$

and

$$\Delta = \frac{v\mu_{\theta_S} - v\mu_{\theta_L}}{vF} = \frac{\mu_{\theta_S} - \mu_{\theta_L}}{F} \dots \dots \dots (2)$$

If we again split up the mol. thermodynamic potential as follows:

$$\mu = \mu' + RT \ln C \dots \dots \dots (3)$$

and if we put:

$$\mu'_{M_S^v} - \mu'_{M_L^v} = RT \ln K_M \dots \dots \dots (4)$$

¹⁾ In the preceding communication III had been erroneously put for IV.

and

$$\mu'_{\theta_S} - \mu'_{\theta_L} = RT \ln K'_0 \quad \dots \quad (5)$$

we get in perfect agreement with our foregoing communication:

$$\Delta = - \frac{RT}{vF} \ln \frac{K'_M \cdot (M'_S)}{(M'_L)} \quad \dots \quad (6)$$

and

$$\Delta = \frac{RT}{F} \ln \frac{K'_\theta(\theta_S)}{(\theta_L)} \quad \dots \quad (7)$$

The last electron-equation is of course the same as for a univalent metal.

If we now combine these two equations, we get:

$$\Delta = \frac{RT}{2vF} \left[v \ln \frac{K'_\theta(\theta_S)}{(\theta_L)} - \ln \frac{K'_M \cdot (M'_S)}{(M'_L)} \right] \quad \dots \quad (8)$$

or

$$\Delta = \frac{RT}{2vF} \left\{ \ln \frac{K'_\theta(\theta_S)}{K'_M \cdot (M'_S)} - \ln \frac{(\theta_L)}{(M'_L)} \right\} \quad \dots \quad (9)$$

If we now again write $K'_\theta(\theta_S) = K_\theta =$ solubility electrons

and $K'_M(M'_S) = K_M =$ „ metal ions,

we get instead of (8) and (9):

$$\Delta = \frac{RT}{2vF} \left[v \ln \frac{K_\theta}{(\theta_L)} - \ln \frac{K_M \cdot (M'_S)}{(M'_L)} \right] \quad \dots \quad (10)$$

or

$$\Delta = \frac{RT}{2vF} \left[\ln \frac{K_\theta}{K_M} - \ln \frac{(\theta_L)}{(M'_L)} \right] \quad \dots \quad (11)$$

The solubility product is in this case:

$$L = (M'_L)(\theta_L) \quad \dots \quad (12)$$

from which therefore follows that when (M'_L) is doubled, the concentration of the electrons becomes smaller by $2^{1/v}$.

If we take this into account in the discussion of equation (11), we see that this change of concentration causes an increase of the *positive*, or a decrease of the *negative* potential difference.

3. Potential difference of the metal with respect to the pure solvent.

From equation (11) the relation for the potential difference for

the case the metal is immersed in a perfectly pure solvent, may be easily derived.

From the equation:

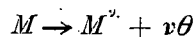

follows that the concentration of the electrons will be ν times as great as that of the metal ions, so that:

$$(\theta_L) = \nu (M_L^{\nu}).$$

If we now substitute this value for (θ_L) in equation (11), we get:

$$\Delta = \frac{RT}{2\nu F} \left[\ln \frac{(K_{\theta})^{\nu}}{K_{M^{\nu}}} - \nu \ln \nu \right] \dots \dots \dots (13)$$

This equation expresses that the potential difference between a ν -valent metal and a pure solvent is entirely determined by the valency and by the solubility of the metal ions and electrons.¹⁾

4. *Polarisation and passivity of a metal that contains only one kind of metal ions.*

Now the question can be answered whether it is possible that a metal, in which in case of unary behaviour the internal equilibrium

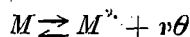

prevails, can be polarized resp. made passive.

To answer this question we start from our equations (6) and (7), from which follows that

$$\frac{(M_L^{\nu})}{K_{M^{\nu}} (M_S^{\nu})} = \frac{(K'_{\theta})^{\nu} (\theta_S)^{\nu}}{(\theta_L)^{\nu}}$$

or

$$\frac{(M_S^{\nu}) (\theta_S)^{\nu}}{(M_L^{\nu}) (\theta_L)^{\nu}} = K \dots \dots \dots (14)$$

As was already stated in the foregoing communication equations (6) and (7) hold generally, hence also when the metal is not in internal equilibrium.

When it is asked how in equations (6) and (7) the fact of the internal equilibrium expresses itself, the answer is, in the constancy of the concentrations (M_S^{ν}) and $(\theta_S)^{\nu}$. If there is no internal equilibrium, then these are not the equilibrium concentrations; but the equations (6) and (7) hold nevertheless, and also (14) derived from them.

¹⁾ Of course this potential difference can only be determined after the metal and the solvent have been made perfectly free from gas.

Now we imagine the case that the metal is so rapidly dissolved anodically or in another way, that the reaction

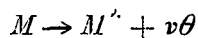

does not proceed rapidly enough to supply the abducted electrons and metal ions, so that the metal gets poorer in these two electrical components. If we now consider that the electrons and the metal ions always neutralize each other electrically, with the exception of only an exceedingly small fraction, then a closer examination of equation (14) gives the following conclusion.

Suppose that the metal ion concentration in the metal (M'_S) becomes n -times smaller by anodic solution etc., then the electron concentration (θ_S) also becomes n -times smaller, so that the numerator of (14) will become n^{v+1} times smaller in consequence of this.

If we further assume, what is allowed for a sufficient quantity of solution, that the ion concentration (M'_L) is constant in the coexisting electrolyte, (θ_L)' will have to become n^{v+1} times as small, from which it appears that the *electron concentration in the coexisting electrolyte* (θ_L) *will decrease to a greater extent than that in the metal* (θ_S).

From equation

$$\Delta = -\frac{RT}{vF} \ln \frac{K' M^v \cdot (M'_S)}{(M'_L)} \dots \dots \dots (6)$$

follows that when (M'_S) becomes smaller, and (M'_L) remains constant, the potential difference will become less negative or greater positive.

When (M'_S) decreases, the result is — as we have seen just now — that $\frac{(\theta_S)}{(\theta_L)}$ becomes *greater*, from which appears in connection with the formula :

$$\Delta = \frac{RT}{F} \ln \frac{K'_\theta(\theta_S)}{(\theta_L)} \dots \dots \dots (7)$$

that the potential difference will become less negative or greater positive.

As was already set forth at length in the preceding communication in the discussion of a univalent metal, this points to the possibility of anodic polarisation and passivity, while perfectly analogous considerations lead to the cathodic polarisation.

These phenomena must then be explained by a too slow establishment of the internal equilibrium between metal atoms, metal ions, and electrons.

5. *The metal contains ions of different valency.*

We shall now suppose that ions of different valency occur in the metal, viz. the ions M^1 and M^2 .

In the metal we then have the equilibria .

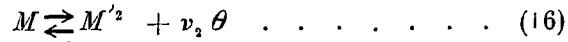
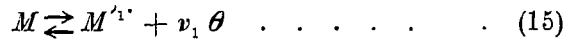

and

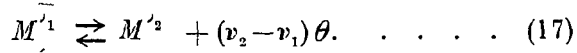

Between the metal and the electrolyte we can then give the equilibria as follows .

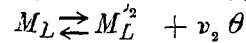
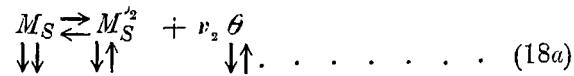
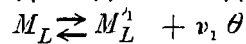

in which it is noteworthy that these equilibria are probably established in the electrolyte with very great velocity, but that they are not established in the dry metal at the ordinary temperature, or exceedingly slowly.

In the case that the metal possesses two different kinds of ions, we have to do with two solubility products viz.

$$L_{M_1} = (M'_L{}^1) (\theta_L)^{v_1} . \dots \quad (19)$$

and

$$L_{M_2} = (M'_L{}^2) (\theta_L)^{v_2} . \dots \quad (20)$$

Supposing that M'^1 is a base and M'^2 is a noble ion, then as we have set forth at length in our former communication, L_{M_1} is comparatively great and L_{M_2} small. If we immerse a homogeneous mixed crystal phase of two salts with homonymous anion, one of which possesses a great, and the other a small solubility product, in water, we have a state which in many respects corresponds with the case supposed here.

Thus the electrolyte, in which the supposed metal is placed, will possess a comparatively great concentration of M'^1 -ions and electrons, θ , but a very small concentration of M'^2 -ions, and that smaller than when the metal contained only M'^2 -ions, because in consequence of the relatively great solubility product L_{M_1} the electron concentration is much greater.

It is clear that the explanations of different electromotive processes given in our preceding communication through application of the idea "solubility product" of a metal are now just as well applicable to this more complicated case as to the simple one. Now, however,

to account for all the important circumstances, we shall have to occupy ourselves with the *three* equilibria (15) (16) and (17).

If we e.g. suppose that the metal is immersed in pure water, and chlorine is added, the metal will be dissolved in consequence of the removal of electrons on account of the small electron concentration of the equilibrium:

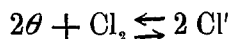

Now equation (17) expresses that a second consequence of this removal of the electrons is an increase of the concentration ratio $\frac{M_L'^2}{M_L'}$.

6 *The equations for the potential difference metal-electrolyte*

For the case supposed here we get for the potential difference metal-electrolyte the equations

$$\Delta = - \frac{RT}{v_1 F} \ln \frac{K'_{M^1} (M_S^1)}{(M_L^1)} \dots \dots \dots (21)$$

$$\Delta = - \frac{RT}{v_2 F} \ln \frac{K'_{M^2} (M_S^2)}{(M_L^2)} \dots \dots \dots (22)$$

and the electron-equation

$$\Delta = \frac{RT}{F} \ln \frac{K'_\theta (\theta_S)}{(\theta_L)} \dots \dots \dots (23)$$

From (21) and (22) now follows

$$\left[\frac{K'_{M^1} (M_S^1)}{(M_L^1)} \right]^{1/2} = \left[\frac{K'_{M^2} (M_S^2)}{(M_L^2)} \right]^{1/2} \dots \dots (24)$$

or

$$\frac{K'^2_{M^1} (M_S^1)^2}{K'^1_{M^2} (M_S^2)^1} = \frac{(M_L^1)^2}{(M_L^2)^1} \dots \dots \dots (25)$$

We shall now assume that K'_{M^1} is very great compared with K'_{M^2} or in other words that the ions M^1 are very much baser than M^2 .

In this case the fraction $\frac{(M_L^1)^2}{(M_L^2)^1}$ is very great, and much greater than $\frac{(M_S^1)^2}{(M_S^2)^1} \frac{K'^2_{M^1}}{K'^1_{M^2}}$ being so exceptionally great.

When $\frac{(M_S^1)^2}{(M_S^2)^1}$ is not very small, $\frac{(M_L^1)^2}{(M_L^2)^1}$ will always be very great positive. Now (M_L^1) can however, not be arbitrarily great, though (M_L^2) can, indeed, be arbitrarily small.

It follows from this that the very great value of the fraction $\frac{(M_L^1)^2}{(M_L^2)^1}$ is caused by the small value of (M_L^2) in the case supposed here.

If we now call the total concentration of the ions C , practically M_L^1 will be $= C$.

In this case we can therefore write for (21).

$$\Delta = -\frac{RT}{v_1 F} \ln \frac{K' M^1}{C} - \frac{RT}{v_1 F} \ln (M_S^1) \dots \dots (26)$$

It then follows from this equation that when the total ion concentration C is constant, the potential difference in the metal will become more strongly negative on increase of the concentration of the base ion M^1 , in the metal and more strongly positive on decrease of this concentration.

7. *The metal assumes internal equilibrium.*¹⁾

Now we shall suppose that in the electrolyte the equilibrium sets in between atoms, ions, and electrons, which is accompanied with a setting in of the internal equilibrium in the metal. If the metal is in internal equilibrium, its state is perfectly determined for definite temperature and pressure, i.e. the concentrations of the atoms, ions, and electrons in the metal are then under these circumstances constant quantities. (M_S^1) and (M_S^2) are constants; hence in connection with (25)

$$\frac{(M_L^1)^2}{(M_L^2)^1} = K' \dots \dots \dots (27)$$

will hold for the coexisting electrolyte.

We can also arrive at this conclusion by another way. When internal equilibrium prevails in the metal, the same equilibria will occur in the coexisting electrolyte as in the metal, viz.:

¹⁾ The internal equilibrium may be defined as the equilibrium in a phase of a unary system.

$$M_L \rightleftharpoons M_L^{v_1} + v_1 \theta_L \quad \dots \quad (15a)$$

$$M_L \rightleftharpoons M_L^{v_2} + v_2 \theta_L \quad \dots \quad (16a)$$

$$M_L^{v_1} \rightleftharpoons M_L^{v_2} + (v_2 - v_1) \theta_L \quad \dots \quad (17a)$$

If we now apply the law of mass action to this equation, we get:

$$K_1 = \frac{(M_L^{v_1}) (\theta_L)^{v_1}}{(M_L)} \quad \dots \quad (28)$$

$$K_2 = \frac{(M_L^{v_2}) (\theta_L)^{v_2}}{(M_L)} \quad \dots \quad (29)$$

$$K_3 = \frac{(M_L^{v_2}) (\theta_L)^{v_2 - v_1}}{(M_L^{v_1})} \quad \dots \quad (30)$$

If by combination of two of these three equations we eliminate the electron concentration, we get the relation:

$$K_4 = \frac{(M_L^{v_2})^{v_1} (M_L)^{v_2 - v_1}}{(M_L^{v_1})^{v_2}} \quad \dots \quad (31)$$

from which appears, as also follows directly by elimination of the electron concentration from the equations (15a) and (16a), that as far as the *final result* is concerned, the equilibrium in the electrolyte, and of course also in the metal, can be considered as follows:

$$v_2 M^{v_1} \rightleftharpoons v_1 M^{v_2} + (v_2 - v_1) M \quad \dots \quad (32)$$

If we now bear in mind that (M_L) is a saturation concentration in the electrolyte, which is in contact with the metal, we get for this case:

$$K_4' = \frac{(M_L^{v_2})^{v_1}}{(M_L^{v_1})^{v_2}} \quad \dots \quad (33)$$

Now that we know that with constant temperature and pressure $\frac{(M_L^{v_1})^{v_2}}{(M_L^{v_2})^{v_1}}$ must be a constant quantity, it is easy to examine the influence of a change of concentration on the potential difference in case of internal equilibrium.

If e.g. we double the concentration, the ratio (27) would become $2^{v_2 - v_1}$ times as great, when no internal transformations took place. As, however, this fraction has to remain constant in case of internal equilibrium $(M_L^{v_1})$ will decrease and $(M_L^{v_2})$ will increase. When we only want to determine in this increase of concentration the direction of the shifting of the equilibrium, of course equation (32) will be sufficient, because, when it is borne in mind that the concentration

of the metal atoms is a saturation concentration, it immediately follows from this equation on application of the principle of the shifting of equilibrium that the equilibrium shifts to the right, v_2 being $> v_1$ on increase of concentration.

It is here the place to point out how easy the application of the electron equation is, at least when our purpose is to indicate the direction of the potential changes.

On examination of equation.

$$\Delta = \frac{RT}{F} \ln \frac{K_0'(\theta_S)}{(\theta_L)} \dots \dots \dots (23)$$

and the equilibrium:

$$M_L^1 \rightleftharpoons M_L^2 + (v_2 - v_1) \theta_L \dots \dots \dots (17a)$$

we can immediately answer the questions under consideration.

When e.g. with constant total concentration we increase the concentration of the M_L^2 -ions, the equilibrium (17a) will shift to the left; and the concentration of the electrons (θ) will decrease.

Equation (23) then expresses that the potential difference will increase.

If we raise the total concentration, the equilibrium (17a) will also shift to the left; also in this case the potential difference rises.

If there were an easy way to find out the electron concentration, it appears from this that the electron equation would be preferable.

8. *Polarisation and passivity of metals with ions of different valency.*

We have seen that for the metals which contain only one kind of ions, polarisation and passivity can occur in consequence of a decrease of the number of ions and electrons in the surface of the metal caused by an insufficiently rapid setting in of the internal equilibrium.

Let us now consider a metal built up of two different kinds of ions, then for the reason mentioned polarisation and passivity will take place also here, but when the internal equilibrium does not set in quickly enough, a second circumstance will take place here causing polarisation and passivity, viz. this that as was already shown in earlier communications, the concentration of the noble ion in the metal surface will increase, and that of the base ion will decrease. It is, therefore, clear that such a metal will be the most suitable material to exhibit the phenomena of polarisation and passivity in all their particulars.

We will once more elucidate this phenomenon somewhat further

here. The most rational proceeding is to start from the case that heterogeneous equilibrium always prevails between the metal and the adjoining liquid layer, that therefore the electrochemical equilibrium always continues to exist.

We can represent this by the following symbols:

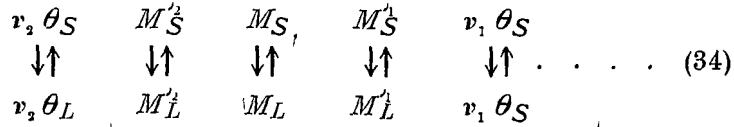

These equilibria, therefore, always exist.

The equilibrium

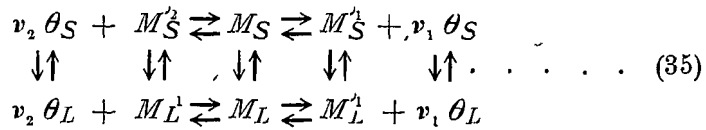

on the other hand only exists, when the unary metal and the electrolyte are in electromotive equilibrium.

During the anodic polarisation, however, only the equilibria represented by (34) exist, the homogeneous equilibria having been interrupted, but transformations take place which, when the current has been interrupted, will again reduce the metal to the unary state, and cause the original electromotive equilibrium to reappear.

Only metals with different kinds of ions being considered, the slow establishing of the internal equilibrium

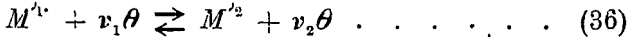

has been given as the cause of the polarisation and the passivity in the preceding communications.

This is perfectly correct, but we may add to this, that even if this equilibrium set in with great velocity, polarisation and passivity would occur all the same when the following equilibria:



and



set in slowly.

Reversely it is immediately seen that when the internal equilibrium (36) does not set in by a direct way, but (37) and (38) set in rapidly, the equilibrium (36) would yet set in with great velocity, but now in an indirect way.

Hence it is clear that the real ground for the possibility of the occurrence of polarisation and passivity is the slow establishment of the internal equilibrium of the equations (37) resp. (38).

Now all kinds of phenomena point to the fact that hydrogen ions very considerably accelerate the setting-in of the internal equilibrium in the metal surface moistened with an electrolyte, and this makes it clear on one side why the polarisation assumes large amounts when we succeed in removing the hydrogen from the metal surface, and why on the other hand the potential of the unary metal (formerly called potentials of equilibrium) sets in most easily when the metal contains many hydrogen ions.

If after anodic polarisation the current is broken off, the disturbance is comparatively quickly cancelled, when the polarisation has not lasted long, and no or little generation of O_2 has taken place, so that the metal was still comparatively rich in hydrogen. If, however, the polarisation has taken place a long time during generation of oxygen, the metal surface has become very poor in hydrogen, and the disturbance continues to exist a relatively long time also after interruption of the current.

This shows the strongly positive catalytic influence of the hydrogen or the negative influence of the oxygen.

The fact that metal poor in hydrogen or rich in oxygen slowly assumes internal equilibrium after interruption of the polarizing current even when in contact with the electrolyte, is astonishing on superficial consideration, when we consider that a rapid setting in of the equilibrium in the liquid, which is, indeed, to be expected, can bring about an internal equilibrium in the metal, even if the velocity of the internal transformations in the metal is practically zero.

For this it is only necessary that the reaction:

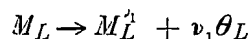

takes place in the electrolyte, and further that uncharged metal atoms go into solution, the metal ions M^+ and electrons from the electrolyte passing into the metal. This astonishment, however, immediately vanishes, when we consider that the saturation concentration of the uncharged metal atoms is so exceedingly small that even if the reaction constant of the reaction (37) were very great, the quantity of metal ions and electrons formed per unity of time, would be exceedingly small. In a separate chapter we shall treat the influence of the small value of the concentration of one of the components of a chemical system on the course of a process. It is, therefore, clear that the transformations in the liquid can practically have *any* part in the establishment of the internal equilibrium in the metal only when a process is concerned that requires a very long time.

Generally, however, the internal equilibrium has been established

in a short time, and then it is, indeed, clear that we must *exclusively* look for the cause of this setting in of the equilibrium in the metal surface.

In this it is supposed that the metal remains in contact with the liquid in which it is polarized, or is transferred to a liquid in which the concentration of the M^{\prime} -ions and electrons is smaller than in the liquid which is in electromotive equilibrium with the unary metal. In this case the reaction

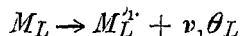

would have to cause a sufficient increase of the concentration of the M_L^{\prime} -ions and electrons in a short time, so that these by deposition on the metal could reduce the latter to the state of internal equilibrium.

In some cases, however, it will be possible to bring the metal in an electrolyte in which the concentration of the M^{\prime} -ions and electrons is greater than in the liquid in electromotive equilibrium with the unary metal, and then, of course, the case is different, for then the M^{\prime} -ions and electrons will deposit on the metal without there being any necessity of the above-mentioned reaction taking place, and in this case the electrolyte will certainly be able to reduce the metal to the state of internal equilibrium in a comparatively short time. If in this way a sufficient quantity of baser ions is deposited, also the occurrence of local currents will greatly accelerate the establishment of the internal equilibrium.

If, however, we do not make use of such a liquid, the electrolyte, as has been said, will have to be left out of account for a rapidly proceeding activation, and the setting in of the internal equilibrium takes place exclusively by transformations in the metal surface, in which the reaction:



will take place, till the equilibrium corresponding to the unary metal:

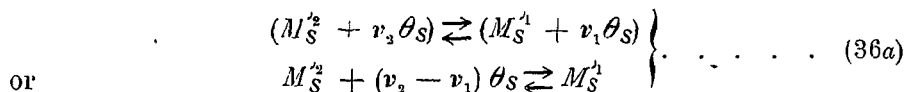

has again set in.

After anodic polarisation it is, therefore, the reaction (38a) that governs the setting in of the internal equilibrium, and speaking generally we may say that a metal can be thrown out of its state of internal equilibrium through the comparatively slow progress of the reversible reactions

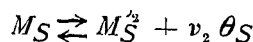
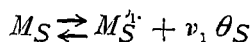

in the metal surface in the absence of catalysis.

This explains not only the anodic polarisation, but also the cathodic and chemical disturbance of the metal.

9. *The influence of the smallness of the concentration of a component on the course of a process.*

In connection with the remark in the preceding chapter that the quantity of metal, which comes to equilibrium via the coexisting liquid, is exceedingly slight, even when the constant of the reaction is very great, we will point out that the same thing holds for all reactions in which one of the reacting components is present in very slight concentration. This should also be taken into consideration with the explanation of different electromotive processes by the application of the idea "Solubility product of the metal" given in the foregoing paper.

That e.g. the action of chlorine water on a metal can be represented by the equations:

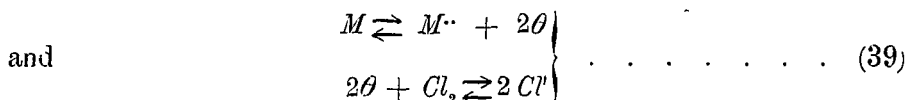

does not imply that a metal brought into chlorine water reacts exclusively or chiefly in this way that the metal dissolves as atom, and splits up into metal ions and electrons, of which the latter are bound to chlorine ions by the chlorine. These equations only mean that the reaction *can* and partly also *will* take place in this way. That the part of the total transformation which takes place according to (39) can be very slight, easily appears in the following way. If the solution is permanently saturated with respect to M , and if $M^{\cdot\cdot} = 1$ then $(\theta) = \sqrt{L_M}$.

The velocity of the reaction

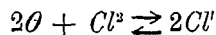

is given by

$$\frac{d(Cl^{\cdot})}{dt} = k (Cl_2) \cdot L_M.$$

The solubility product of a metal that does not decompose water being smaller than 10^{-10} , the quantity Cl^{\cdot} formed in this way will be only insignificant, even for a very great value of k .

As the same thing holds for all other reactions in which a metal

reacts, as has been set forth here for the action of chlorine, we shall have to assume that the transformations to which a metal is subjected, practically take exclusively place at the surface of the solid metal. Thus e.g. the generation of hydrogen, the deposition of a nobler metal by a less noble one etc. Considerations like those that have been applied in § 3 of the preceding papers, have also been frequently applied for other transformations, not however for the purpose of showing how the reaction in reality proceeds for the greater part, but to indicate *in what direction the transformation must take place, and what final state is reached.*

We remind e.g. of the transformation of one modification of a substance into another. The most stable form having the smallest vapour tension and the smallest solubility, it is clear that the metastable form must be transformed into the more stable form in contact with vapour or solution. This, however, does not mean that this transformation always takes place chiefly over the vapour or the solution, on the contrary it may be predicted with certainty in virtue of what was derived above, that these transformations, when they take place quickly, do not take place via the vapour or the solution; this can only take place when the transformation takes place exceedingly slowly.

Also for the dissolving of a deposit by the addition of reagents generally the conception is used that the deposition goes into solution, and is then converted in the aqueous solution by the added substance. The solution of $CaCO_3$ into HCl e.g. is represented as follows:

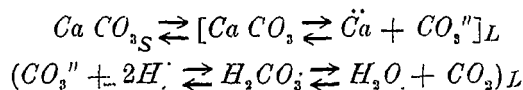

and the solution of $AgCl$ in NH_3 by the equations:

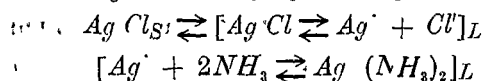

The equations, however, only serve to show that $CaCO_3$ dissolves in HCl and $AgCl$ in NH_3 , and what conception can be used then in connection with the equilibria that can occur in the said system.

But it does not follow at all from this that $CaCO_3$ really chiefly goes into solution in this way. In connection with the slight solubility of the substance in water this is certainly by no means the case, and the solution must therefore take place by the action of HCl or H_2 on the *solid* $CaCO_3$, and of NH_3 on the *solid* $AgCl$. The same objection that a reaction would proceed quickly with a very small concentration of one of the reacting components has already been discussed with the electrolytic deposition of metal from

solutions of complex cyanides. HABER¹⁾ showed, namely, that when we wanted to attribute the metal deposition in these cases to direct discharge of the elementary metal ions, the velocity with which these are formed from the complex ions, would have to be exceedingly great, much greater than any known velocity. HABER, therefore, assumes that the deposition of metal takes place, not by the discharge of the elementary metal ions, which are present in a very small quantity, but because the complex ions $M(CN)_2$ present in large quantities, combine with an electron, and split up into M and $2CN$.

10. *Polarisation during the electrolytic generation of halogens, oxygen etc.*

It has therefore appeared from what precedes that the ionisation or the splitting off of electrons is a process that proceeds comparatively slowly in some cases.

Also in the electrolytic generation of the halogens, of oxygen etc., polarisation phenomena have been observed, which points to the fact that here too relative retardations come into play. The electrolytic generation consists in a splitting off of electrons, as the following equation indicates:



And as for metals we are compelled to assume that the splitting off of an electron from a neutral atom proceeds comparatively slowly, it is natural to assume that the splitting off of an electron from a negatively charged atom does not proceed with an infinite velocity either, so that this process too can be relatively retarded for a definite current density.

The concentration of the electrons in the liquid being exceedingly small, the generation of Cl will take place practically exclusively at the metal surface. We can now imagine that at the surface of the metal which is in equilibrium with chlorine and chlorine ions, the following equilibria exist:

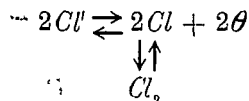

When the splitting of chlorine ions in atoms and electrons at the boundary surface metal-solution is relatively retarded above a certain current density, the concentration of the chlorine ions will be too great in the boundary layer, and that of the electrons too small.

¹⁾ Z. Elektr. 10 (1904) 433, 773.

Consequently the metal will exhibit a potential that is more positive than the equilibrium potential.

OBSERVATION.

Analogous considerations as those on page 135, given there of a metal in a solution of its ions and electrons, hold for every equilibrium between coexisting phases which contain charged particles of different solubility. In this case a potential difference will always occur, given by the equation $\Delta = -\frac{\mu_1 - \mu_2}{vF}$, where μ_1 and μ_2 indicate the molecular thermodynamic potentials of the charged particles in the two phases. As these in general will not be the same, there must exist a potential difference.

This applies then also e.g. for a salt in equilibrium with its saturate solution, for a solid salt in equilibrium with its melt etc.

Amsterdam, May 25, 1916. Anorg. Chem. Lab. of the Univ.

Physics. — “*On Diffusion in Solutions.*” I. By Dr. J. D. R. SCHEFFER and Dr. F. E. C. SCHEFFER. (Communicated by Prof. A. F. HOLLEMAN).

(Communicated in the meeting of May 27, 1916).

1. *Introduction.* EINSTEIN has derived expressions which indicate how the mean square of the deviation of a Brownian particle and the diffusion constant depend on the nature of the substances and the temperature¹). The relation between the Brownian movement, indicated by :

$$\overline{\Delta^2} = \frac{RT}{N} \frac{1}{3\pi a \zeta} t, \dots \dots \dots (1)$$

and the diffusion constant is expressed by :

$$D = \frac{\overline{\Delta^2}}{2t}, \dots \dots \dots (2)$$

so that for the latter

$$D = \frac{RT}{N} \frac{1}{6\pi a \zeta}, \dots \dots \dots (3)$$

is found, an expression, which can also be found by a direct way by making use of the osmotic pressure, which as apparent force causes the diffusion, and the law of STOKES, which gives the resist-

¹) EINSTEIN. Ann. d. Phys (4) 19. 289. 371 (1906). Zeitschr. f. Elektrochem. 14. 235 (1908)

ance which a solid sphere encounters when moving in a medium in which the free path is small with respect to the radius of the sphere. EINSTEIN has namely demonstrated that for the cause of the diffusion we may substitute a force acting on the diffusing particles, which is equal to the osmotic pressure¹⁾. Like 1 the expression 3 holds, therefore, only for particles which are great with regard to the free path.

When we now examine what experimental confirmations for the expressions 1 and 3 are to be found in the literature, it appears that for particles with a diameter of the order 10^{-4} and 10^{-5} cm. chiefly equation 1 has been tested. Generally the procedure of testing is carried out in this way that the mean square of deviation is calculated from the observed deviations and then N is determined from equation 1. PERRIN's experiments, carried out with particles the radius of which varied between 2.10^{-5} and 5.10^{-4} cm., yielded values for N oscillating between 5.5 and $8.0 \cdot 10^{23}$. PERRIN's most accurate determinations carried out with particles of equal size, yielded $N = 6.9 \cdot 10^{23}$.²⁾ Of late values have been found for N which are lower³⁾ and have got closer to MILLIKAN's $6.06 \cdot 10^{23}$ ⁴⁾, which value is pretty generally considered as the most reliable one.

With regard to the diffusion it is noteworthy that the diffusion constant of these particles is very difficult to determine on account of the slight velocity at the ordinary temperature. Only by a very particular mode of procedure PERRIN has succeeded in finding a value for the diffusion constant. In his determinations the property was made use of that gamboge particles, moving in glycerine, adhere to a glass wall when colliding with it. So the quantity of particles adhering to the wall continually increases, when the suspension is brought into a vessel, and the diffusion constant can be calculated from the number that is found on the wall at different times. In this way BRILLOUIN found the value $N = 6.9 \cdot 10^{23}$ in PERRIN's laboratory⁵⁾. Accordingly the expressions 1 and 3 give satisfactory results for particles of the order 10^{-4} and 10^{-5} cm.

Likewise experiments have been made with colloidal solutions as a test of the equations 1 and 3. The Brownian movement has been

¹⁾ EINSTEIN. Ann. d. Phys. (4) 17. 549. (1905).

²⁾ PERRIN. Compt. rend. 146 seq. A summary of these experiments is found in DE HAAS—LORENTZ. Die Brownsche Bewegung und einige verwandte Erscheinungen. Die Wissenschaft. Band 52. (1913).

³⁾ NORDLUND. Zeitschr. f. physik. Chemie 87. 40. (1914).

⁴⁾ MILLIKAN. Phys. Zeitschr. 14. 796 (1913).

⁵⁾ BRILLOUIN. Ann. chim et phys. (8) 27 412 (1913). Cf however WESTGREN. Zeitschr. f. physik. Chem. 89. 63. (1914).

closely studied especially with regard to gold sols by THE SVEDBERG ($N = 6.2 \cdot 10^{23}$)¹⁾, and also the diffusion determinations yielded values which on the whole present a same dependence on the radius as equation 3 leads us to expect²⁾.

If we examine what the expressions 1 and 3 can yield for ordinary solutions, it appears that only 3 is liable to be tested, and that the following conclusions offer the best opportunity.

1. In the same solvent the product of diffusion constant and radius of the diffusing molecule is constant. The relative size of the dissolved substances can, therefore, be determined from the diffusion constant. It is clear that we can only speak of testing here, when it is possible to compute the radii by another way. According to expression 3 THE SVEDBERG found for the radius of some organic substances values which at least roughly³⁾ agree with our views of chemical structure. The volume of the dissolved substance in pure state and the atom constants which follow from the additivity of the b of the equation of state, can likewise furnish an estimation of the radius. Another method to find the radius of the diffusing particle has been given by EINSTEIN⁴⁾; it is founded on the change in viscosity which a solvent undergoes, when large solid spheres are suspended in it; we shall return to this later on.

2. for diffusion of a substance in different solvents at the same temperature the product of diffusion constant and internal friction is constant. Here we should call attention to an investigation by THOVERT; who for diffusion of phenol in ten different solvents found values for this product which only vary between 92 and 99, the ratio of the diffusion constants even rising to 300⁵⁾. For a number of substances diffusing in alcohol and water OEHOLM has found radii of about equal length; hence $D\zeta$ also for these substances differs little in alcohol and water⁶⁾. An extensive investigation by OEHOLM with other solvents, has, however, yielded values for the radius of the same diffusing particle which are to each other as 1:2 and even as 1:3⁷⁾; this may be attributed to difference in molecular size of the dissolved substance (association), to the non-

1) THE SVEDBERG and INOUE. Kolloid Zeitschr. 1 No. 7 (1910); 2 No. 9 (1911). Cf. also WESTGREN l. c.

2) THE SVEDBERG. Zeitschr. f. physik Chemie. 67. 105. (1909)

3) THE SVEDBERG and A. ANDREEN-SVEDBERG, Zeitschr. f. physik Chemie. 76, 145 (1911).

4) EINSTEIN. Ann. d. Phys. (4) 19, 289 (1906); (4) 34, 591 (1911).

5) THOVERT. Ann. chem. et phys. (9) 2, 369 (1914).

6) OEHOLM. Meddelanden Nobelinstitut. 2. No. 24 (1912).

7) OEHOLM. Meddelanden Nobelinstitut. 2. No. 26 (1913).

fulfilment of the condition that the radius is great with respect to the free path or to binding of the dissolved substance with the solvent.

It may finally be remarked that HERZOG calculates the molecular weight from the specific volume of the dissolved substance in solid state and the diffusion constant by the aid of equation 3, and that he finds it in agreement with the known value as far as the order of magnitude is concerned. He derives from this a method to determine molecular weights of large molecules, for which osmotic methods do not give results ¹⁾.

3. for the same substance in the same solvent the influence of the temperature can be examined. No data are to be found in the literature about this. The reason for this is that the determination of diffusion constants, which is attended with great experimental difficulties even under ordinary circumstances, becomes still more difficult with higher temperature. Of late we have been occupied with testing equation 3 at different temperatures; what follows gives the description of our experiments and the results yielded by this investigation.

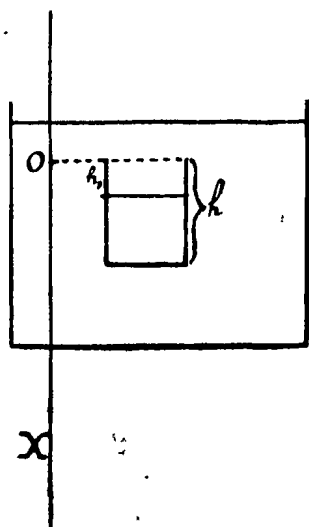

Fig. 1.

2. *Method of investigation.* The great difficulty which attends diffusion experiments at higher temperature is the keeping constant of the temperature; in the ways of research followed up to now a constant temperature is very difficult to attain on account of the large dimensions of the apparatus. We have tried to obtain satisfactory results by the application of a micromethod. GRAHAM'S first method which appeared to be suitable for this purpose is based on what follows. A diffusion vessel is filled with solution up to a certain height, then pure water is added till it is full, and it is placed in a vessel with pure water. If in fig. 1 the X -axis is laid vertically downward, the origin O at the level of the upper section, then the differential equation for the diffusion:

$$\frac{\partial c}{\partial t} = D \frac{\partial^2 c}{\partial x^2}$$

yields on integration with the initial conditions:

¹⁾ HERZOG. Zeitschr. f. Elektrochem. 16. 1003 (1910).

$$c = c_0 \text{ between } x = h_1 \text{ and } x = h$$

$$c = 0 \text{ between } x = 0 \text{ and } x = h_1,$$

and the limiting conditions:

$$\frac{\partial c}{\partial x} = 0 \text{ for } x = h \text{ and}$$

$$c = 0 \text{ for } x = 0$$

the expression ¹⁾:

$$c = \frac{4c_0}{\pi} \sum_{p=0}^{\nu=\infty} \frac{1}{2p+1} \cos \frac{(2p+1)\pi h_1}{2h} \sin \frac{(2p+1)\pi x}{2h} e^{-\left(\frac{2p+1}{2h}\pi\right)^2 Dt} \quad (4)$$

The quantity which has flowed through the upper section in a definite time t , is indicated according to FICK'S law by:

$$Q = \int_0^t Dq \left(\frac{\partial c}{\partial x} \right)_{x=0} dt,$$

in which q represents the section of the vessel.

From 4 we find for this value:

$$Q = \frac{8c_0 q h}{\pi^2} \sum_{p=0}^{\nu=\infty} \frac{\cos \frac{(2p+1)\pi h_1}{2h}}{(2p+1)^2} \left(1 - e^{-\left(\frac{2p+1}{2h}\pi\right)^2 Dt} \right).$$

If we choose $h_1 = \frac{1}{3} h$, it is clear that in consequence of $\cos \frac{(2p+1)\pi h_1}{2h}$ becoming zero for $p=1$, the second term of the quickly converging series disappears; therefore the first term suffices for a great number of the determinations. This method of working had been applied by one of us before. ²⁾

In the determinations mentioned below we have taken $h_1 = 0$ for experimental reasons; the filling of the diffusion cylinders up to $\frac{2}{3}$ of their height for temperatures that differ from that of the surroundings is namely accompanied with great difficulties.

For our case $h_1 = 0$, and the cosine disappears from all the terms; the series, however, remains complete, so that generally two or three terms must be used for the calculation of the experiments. If Q_0 represents the quantity of substance originally present, the value of the relative rest for a time t becomes:

$$\frac{Q_0 - Q}{Q_0} = \frac{8}{\pi^2} \left(e^{-\frac{\pi^2}{4} \frac{Dt}{h^2}} + \frac{1}{9} e^{-\frac{9\pi^2}{4} \frac{Dt}{h^2}} + \frac{1}{25} e^{-\frac{25\pi^2}{4} \frac{Dt}{h^2}} + \dots \right) \quad (5)$$

¹⁾ SIMMLER and WILD, Pogg. Ann. **100**. 217. (1857).

²⁾ J. D. R. SCHEFFER. Ber. der Deutsch. Chem. Gesellsch. **15**. 788 (1882) and **16**. 1903 (1883).

From this equation table I has been calculated by means of which the value of the diffusion constant can be found if the time of diffusion and the height of the vessel are known.

TABLE I.

$\frac{Q_0-Q}{Q_0}$	$\frac{Dt}{h^2}$	$\frac{Q_0-Q}{Q_0}$	$\frac{Dt}{h^2}$
0.80	0.03141	0.54	0.16630
	322		718
0.79	0.03463	0.53	0.17364
	338		734
0.78	0.03801	0.52	0.18117
	354		753
0.77	0.04155	0.51	0.18886
	369		769
0.76	0.04524	0.50	0.19673
	385		787
0.75	0.04909	0.49	0.20478
	400		805
0.74	0.05309	0.48	0.21303
	417		825
0.73	0.05726	0.47	0.22145
	431		842
0.72	0.06157	0.46	0.23007
	448		862
0.71	0.06605	0.45	0.23891
	463		884
0.70	0.07068	0.44	0.24795
	480		904
0.69	0.07548	0.43	0.25721
	495		926
0.68	0.08043	0.42	0.26670
	511		949
0.67	0.08554	0.41	0.27643
	525		973
0.66	0.09079	0.40	0.28641
	542		998
0.65	0.09621	0.39	0.29664
	558		1023
0.64	0.10179	0.38	0.30714
	574		1050
0.63	0.10753	0.37	0.31793
	588		1079
0.62	0.11341	0.36	0.32901
	605		1108
0.61	0.11946	0.35	0.34041
	621		1140
0.60	0.12567	0.34	0.35216
	638		1175
0.59	0.13205	0.33	0.36424
	651		1208
0.58	0.13856	0.32	0.37671
	669		1247
0.57	0.14525	0.31	0.38957
	685		1286
0.56	0.15210	0.30	0.40285
	702		
0.55	0.15912		
	718		

The apparatus in which the diffusion takes place, is represented in fig. 2; it consists of a glass beaker *A* of 2½ liters of wide shape, placed on a tripod with double copper gauze. In the beaker on the wooden frame *B*, which surrounds the whole apparatus, are suspended the toluol regulator *C* and six test tubes *D*, one of which (*D*₁) is filled halfway, its height with the solution, the others (*D*₂₋₆) with pure water. For the heating a BUNSEN burner is used. At the beginning of a diffusion experiment seven glass cylinder holders *E*,

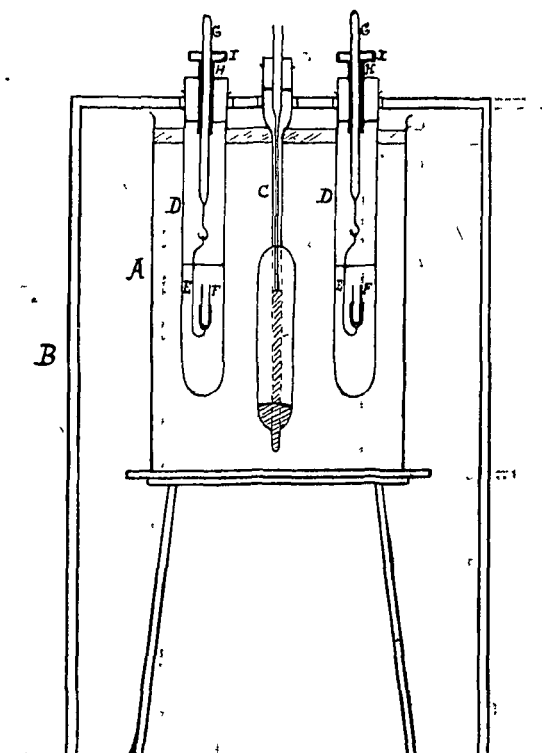

Fig. 2.

each provided with a diffusion cylinder *F* (*F*₁₋₇) are placed in the test tube with the solution (*D*₁), after the cylinders *F* of a diameter of 1½ mm. and a length of about 2 cm. have been filled with the solution by means of a pipette. When the whole apparatus has been brought to constant temperature, two or three of the cylinders (*F*₁₋₃) from the test tube *D*₁ are successively immersed in another (*D*₂) with pure water; this takes place by means of the tube *G*, which easily moves in the glass tube *H*; in rest it is supported by the movable cork disk *I*. These three cylinders (*F*₁₋₃) are taken out of the water immediately after the immersion. In the same way the cylinders (*F*₄₋₇), which have been left in *D*₁ are immersed

with holders in the test tubes D_{3-6} . The cylinders are taken out of the water after a definite time.

Then the contents are conveyed to a glass cup (K_{1-7}) by means of a pipette and by repeated rinsing of the cylinder with distilled water. The cups are made of small thin-walled glass spheres (diameter $\pm 1\frac{1}{2}$ cm.) which were cracked off along a small circle, the rim being fused a little to prevent the glass from further cracking (see

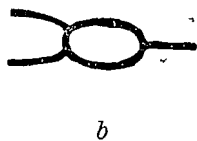
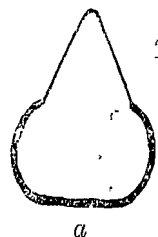

Fig. 3.

fig. 3a). Then the bottom side was heated, till a flat bottom was formed, and a platinum wire was fused with both ends to the upper edge. A light glass tray (fig. 3b) may be laid on the cup, which rests on the rim of

the cup with three glass rods, and serves to bear the weights. The cups K_{1-3} therefore contain the original solution, the other four K_{4-7} the diffusion rests. The ratio of the capacities of the diffusion cylinders was determined by weighing with mercury (for this purpose they were weighed empty, and after they had been filled with mercury and the superfluous mercury had been pressed off with a small glass plate they were weighed again). The filled cups were evaporated to dryness at 100° in an apparatus according to VICTOR MEYER¹⁾, and conveyed to a desiccator with strong sulphuric acid. The quantity of dissolved substance in the original solution of each cylinder H_{4-7} could then be calculated from the increase in weight

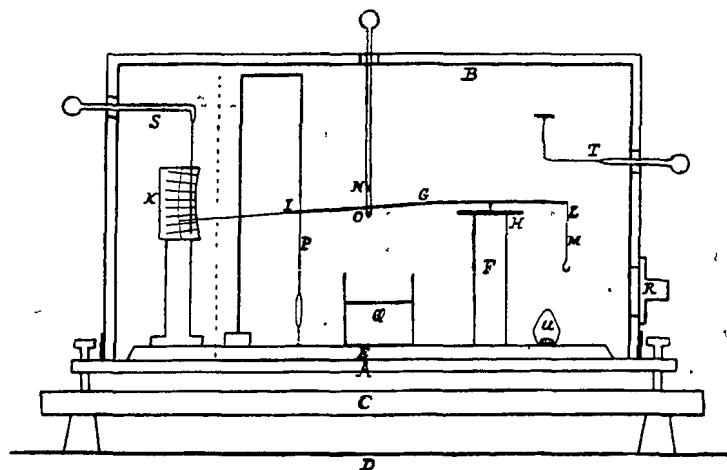

Fig 4.

¹⁾ V. MEYER. Ber. der Deutsch. Chem. Gesellsch. 18. 2999. (1885).

of the three first cups; its mean value furnished the initial quantity. The increases in weight of K_{4-7} yielded the diffusion rests.

The cups were weighed in the balance represented in fig. 4. The preparation of a micro balance suitable for our purpose has presented many difficulties; after a great many futile attempts we have succeeded in making an efficient apparatus, with which all the experiments described below have been carried out, and which has proved very satisfactory. The balance consists of a wooden bottom *A*, provided with three levelling screws and a detachable wooden case *B*, the front side of which consists of glass. The balance rests on a board *C*, which is placed with three rubber stops on the wall bracket *D*. On the bottom lies the glass plate *E*, on which the stand *F* has been cemented. The beam *G* consists of a thin glass rod provided with a piece of a razor, which is fastened to the beam with sealing wax, and rests free on the glass plate *H*. One extremity of *G* ends in a thin glass fibre *I*, which moves along a scalar division on the celluloid plate *K*. To the other extremity of the beam is fastened a very thin quartz thread *L*, provided with a glass hook *M*, which serves for the suspension of the cups. The beam is restricted in its movement by the horizontal glass rods *N* and *O*, so that only small oscillations are possible. Further the plumb *P*, hanging over a mark on the bottom, the drying vessel with concentrated sulphuric acid *Q*, and the plate *R*, which serves for the adjustment and removal of the cups, are indicated in the figure. During the weighing no displacement of the razor in the direction left-right takes place on careful manipulation, at least if the plate *H* has been placed quite horizontal by the aid of a level or a ball from a cycle bearing; the only movement that takes place is a small rotation round the vertical axis which removes the pointer somewhat from the scale *K*. The glass tube *S* serves to keep this distance always very small, which is required for the reading of the position of the pointer in the microscope, which stands horizontally before *K*. Tube *S* ends in a very thin glass thread, and can be rotated by a handle outside the case. If a movement of the beam in the direction left-right should have taken place, the original position can be restored by bringing the beam on *O* and the cork disk of *T*, which can again be rotated round a horizontal axis from the outside, and can be slid in and out. Accordingly the balance case need only be removed for the refreshing of the drying substance *Q*. The microscope has an ocular micrometer; the value of the scalar divisions *K* is expressed in that of the micrometer as unity. The weights used are likewise gauged by means of the ocular micrometer.

For this purpose the scalar value of the smallest weight was first directly determined and then that of the difference between two successive ones. Every weight, the largest weighs about 3 mgr., the smallest 0.2 mgr., corresponds therefore to a known number of scalar divisions. The weighing takes place according to the compensation method. A cup (fig. 3a) with the tray (fig. 3b) and a number of weights is hung on the balance, so that the pointer can freely move along the scale; its position is read in the microscope. If the cup is filled with substance, the pointer is again brought to about the same position by removal of weights from the tray. After correction for different position of the pointer before and after the weighing the removed weights show the quantity of substance in the cup, expressed in the scale of the ocular micrometer. Before and after every weighing the zero position of the balance is determined by the aid of a test tray U , which always remains in the balance. Every scalar division of the micrometer corresponds to 0.003 mgr. and allows an estimation down to fourths. To exclude temperature influences as much as possible during the weighing, the glass of the balance right of the scale is protected by a piece of white card-board.

3. *Results.* For equation 3 to be applicable, the diameter of the dissolved substance must be large with respect to the free path

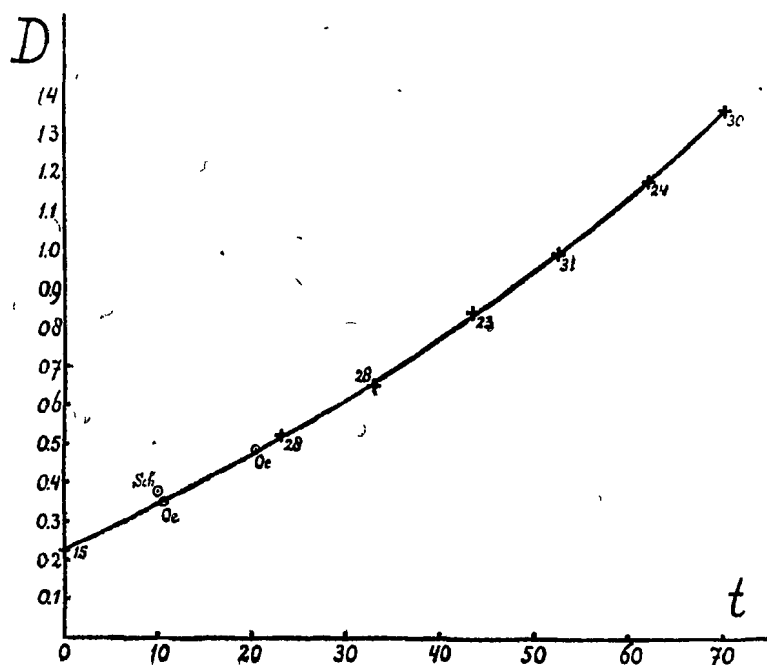

Fig. 5.

of the solvent. We have chosen mannite as dissolved substance for our experiments, because the molecular weight (182) is large compared with that of water, and because it can easily be determined by weight after drying at 100°. Mannite (Ph. Ned. IV) was recrystallized from alcohol and dried. (Spt. 166 $\frac{1}{2}$ °). To obtain sufficiently reliable values for the diffusion-constant, we have made a great number of determinations at different temperatures, and determined the mean values of the series of experiments; the results are recorded in table II, III, and IV, the mean values are given in a $D-t$ diagram (fig. 5) (see p. 157). ($D = [\text{cm}^2 \cdot 24 \text{ hours}^{-1}]$). At any point the number of observations is given which has contributed to that mean.

TABLE II.

Number of the cylinders	1	2	3	4	5	6	7	8
Capacity in mg. mercury (18°)	854.3	611.7	683.0	470.8	555.8	520.4	515.9	529.1
Height in cm. ¹⁾	—	—	—	1.748	2.050	1.895	1.935	—

4. *Conclusions concerning the radius of the mannite molecule.* Equation (3) is valid for infinitely diluted solutions, in which the dissolved particles move through the medium independently of each other. ζ represents the internal friction of the solvent, in our case water, and D the diffusion constant for infinite dilution.

OEHOLM derived 0.513 for D_{∞} from his experiments with the normalities 0.5, 0.25, and 0.125 at 20°, which value is about 6% higher than the value 0.485, which was found by him for a solution of 0.25 normal. This is comparable with our observations, in which the strength of the solutions varies between 30 and 70 grams per liter (± 0.2 and 0.4 norm.). The values found by OEHOLM for this concentration have been inserted in the graphical representation²⁾. If the same change of the diffusion constant with the concentration

¹⁾ The height was determined by means of a piece of a knitting needle which was slid into the diffusion cylinders till it reached the flat bottom. The total length and the part projecting outside the cylinder were measured by the aid of the ocular micrometer and of a millimeter division on glass.

²⁾ OEHOLM. Meddelanden Nobelinstitut. 2 No. 23 (1912): The value found by one of us before, viz.: $D_{100} = 0.38$ is, evidently slightly too high, which will probably be owing to variations of temperature, which were inevitable on account of the long duration of the experiments (21—27 days). (Ber. der Deutsch Chem. Gesellsch. 15. 797 (1882)).

TABLE III.

Temperature	Time (in minutes)	Original quantity			Diffusion rest and constant				Constant (mean)
		1	2	3	4	5	6	7	
0	2366	665.1	479.3	—	226.8	296.5	259.8	248.3	0.226
					0.214	0.202	0.224	0.264	
0	2313	693.5	494.2	553.8	229.9	299.6	269.8	—	0.231
					0.236	0.230	0.228	—	
0	1892	880.8	626.7	707.8	316.5	407.5	361.0	362.5	0.222
					0.221	0.209	0.230	0.227	
0	2316	879.2	631.7	705.7	297.3	381.2	344.5	345.8	0.226
					0.225	0.231	0.225	0.224	
23	1668	838.7	594.3	670.2	225.0	303.0	267.0	271.0	0.549
					0.543	0.559	0.551	0.544	
23	1447	848.2	608.8	677.7	241.5	324.7	290.7	296.8	0.544
					0.559	0.558	0.538	0.519	
23.3	1234	849.8	604.2	677.5	266.7	348.7	308.0	309.5	0.526
					0.515	0.520	0.535	0.535	
23.3	1268.5	—	609.8	679.8	263.8	351.3	312.7	318.0	0.503
					0.522	0.501	0.504	0.485	
23.3	1746	868.0	625.3	696.5	238.5	319.2	277.5	280.3	0.520
					0.502	0.519	0.530	0.529	
23.3	1195	868.7	620.5	—	278.0	358.5	325.5	329.0	0.508
					0.507	0.530	0.502	0.491	
23.3	1921	874.8	627.3	—	222.2	314.5	268.0	272.8	0.516
					0.526	0.497	0.524	0.517	
32.3	417	824.5	—	659.7	328.7	414.3	374.0	378.5	0.613
					0.636	0.593	0.637	0.585	
32.4	733.5	834.0	596.2	666.3	289.2	372.8	336.2	331.5	0.646
					0.646	0.633	0.632	0.673	
33.1	761	—	552.3	617.2	262.2	334.7	310.3	310.3	0.650
					0.668	0.695	0.617	0.621	
33.1	820	834.2	593.0	673.5	282.2	359.2	320.5	324.5	0.657
					0.630	0.665	0.677	0.656	
33.1	975	839.7	600.0	677.8	261.5	346.3	308.5	312.2	0.661
					0.675	0.659	0.661	0.647	
33.1	994	856.2	603.7	685.8	269.5	351.8	306.3	313.7	0.652
					0.632	0.639	0.687	0.650	

Temperature	Time (in minutes)	Original quantity			Diffusion rest and constant				Constant (mean)
		1	2	3	4	5	6	7	
33.1	1032	857.0	614.5	691.7	261.0	346.5	308.7	312.2	0.666
					0.677	0.668	0.665	0.653	
43	707	785.2	565.8	—	260.5	332.5	295.8	297.5	0.824
					0.782	0.829	0.845	0.841	
43.3	667	—	532.3	596.5	238.5	—	287.0	287.8	0.852
					0.909	—	0.822	0.824	
43.3	821	1048.5	—	—	310.7	421.7	373.3	627.8)	0.856
					0.891	0.833	0.844	—	
43.5	678	980.2	701.5	—	320.5	416.5	—	378.0	0.833
					0.842	0.843	—	0.815	
43.5	973	985.0	—	—	287.2	369.3	335.7	603.3)	0.840
					0.801	0.894	0.825	—	
43.5	969	1008.0	714.0	—	284.7	390.8	335.8	612.5)	0.834
					0.846	0.798	0.858	—	
43.5	1101	—	953.2	823.0 ²⁾	350.8	481.0	420.3	429.7	0.849
					0.856	0.852	0.855	0.832	
52.2	1159	1066.8	765.0	—	254.0	358.5	306.2	306.5	0.982
					0.970	0.962	0.985	1.009	
52.2	648	1076.0	750.3	690.2 ²⁾	335.5	457.2	399.3	400.7	0.961
					1.014	0.893	0.967	0.970	
52.2	1146	1110.8	801.0	700.5 ²⁾	265.0	377.0	325.7	323.3	0.985
					0.990	0.968	0.972	1.011	
52.2	717	1132.8	809.8	—	343.0	455.5	396.5	399.5	0.996
					0.977	0.964	1.023	1.020	
52.3	535	1504.7	—	943.7 ²⁾	503.5	649.5	584.8	586.3	1.021
					1.016	1.031	1.017	1.020	
52.4	750	1438.3	1017.7	904.8 ²⁾	427.8	572.8	518.2	—	0.948
					0.980	0.958	0.907	—	
52.4	477	1498.3	1072.2	932.5 ²⁾	516.5	672.5	601.5	594.8	1.007
					1.021	0.964	0.995	1.048	
52.4	1314	—	1179.3	1012.2 ²⁾	348.5	514.5	435.0	451.3	0.984
					1.009	0.973	0.993	0.960	

1) Original substance.

2) Cylinder 8.

Temperature	Time (in minutes)	Original quantity			Diffusion rest and constant				Constant (mean)
		1	2	3	4	5	6	7	
59.6	843	892.8	—	699.6	234.0	309.0	282.1	276.2	1.146
					1.110	1.208	1.093	1.172	
61.9	981	—	799.2	680.0 ¹⁾	256.8	355.2	327.0	309.3	1.199
					1.192	1.248	1.102	1.252	
62.2	741	1079.5	—	669.2 ¹⁾	297.3	392.0	352.8	364.3	1.180
					1.171	1.254	1.180	1.114	
62.4	530	1038.5	748.0	647.2 ¹⁾	340.2	423.8	389.2	389.7	1.165
					1.085	1.263	1.150	1.161	
62.6	717	991.7	712.0	615.7 ¹⁾	280.2	371.2	335.5	329.2	1.170
					1.150	1.201	1.125	1.203	
63.2	568	—	852.8	736.7 ¹⁾	364.2	496.3	435.5	433.7	1.149
					1.204	1.079	1.141	1.173	
68.2	557.5	1106.6	783.9	—	334.2	434.7	385.3	—	1.295
					1.250	1.317	1.319	—	
69.9	688	798.3	568.3	—	222.2	286.6	263.4	254.4	1.300
					1.225	1.379	1.233	1.365	
70.2	521	843.1	614.8	703.9	258.3	354.8	300.0	315.0	1.323
					1.377	1.225	1.427	1.262	
70.2	549	—	678.2	761.5	—	384.8	335.5	330.7	1.308
					—	1.233	1.306	1.384	
70.3	684	1052.7	—	831.9	280.7	—	329.9	326.8	1.389
					1.335	—	1.385	1.446	
70.3	304	1183.7	844.1	—	427.3	552.9	487.5	—	1.321
					1.342	1.231	1.390	—	
70.7	461	1097.9	783.7	880.5	337.3	—	404.0	410.8	1.393
					1.468	—	1.381	1.329	
70.7	550.5	1196.5	861.3	—	347.7	463.8	411.3	411.0	1.422
					1.413	1.422	1.411	1.441	
71.2	574.5	711.2	—	583.5	207.8	272.6	240.9	—	1.419
					1.369	1.449	1.439	—	

continues to exist also at other temperatures, then on substitution of the values of D found by us in equation 3 values for α will be found, which may diverge a few percentages from the real ones.

¹⁾ Cylinder 8.

The real values can then be about 6% *smaller* than those calculated in table IV. The calculated values are of the expected order of magnitude, and change little with the temperature.

TABLE IV.

T	D	$5 \cdot 10^6$	$a \cdot 10^8$
0	0.22 ⁶	1797	4.2
23.2	0.52 ⁴	935	3.8
32.9	0.64 ⁹	755	3.9
43.4	0.84 ¹	618	3.8
52.3	0.98 ⁷	531	3.9
62.0	1.16 ⁸	459	3.9
70.2	1.35 ²	406	3.9

In the calculation of the radius use has been made of the determinations of the internal friction of BINGHAM and WHITE¹⁾ and of the N -value of MILLIKAN²⁾.

In a following paper we shall communicate the results of a series of experiments, which enable us to determine the value of the radius by another way.

The diffusion experiments will be continued with other substances.

Physiology. — “*The movements of the heart and the pulmonary respiration with spiders*”³⁾. By Dr. V. WILLEM (Ghent). (Communicated by Prof. VAN RIJNBERK).

(Communicated in the meeting of May 27, 1916).

We do not know anything about the respiratory movements with spiders. The only modern investigator who has tried to find them experimentally, was F. PLATEAU, he applied in vain to Arachnida the artificial methods that had succeeded with insects; not a single method of investigation made him find the slightest change of the shape of the body that could be attributed to inhalation or exha-

¹⁾ BINGHAM and WHITE. Zeitschr. f. physik. Chemie 80 684 (1912).

²⁾ l. c.

³⁾ According to investigations made in the Physiological Laboratory of the University of Amsterdam.

lation¹⁾. It seems that this failure of so dexterous and careful an investigator, as F. PLATEAU was, has detained naturalists from making any new experiment, to my knowledge there does not exist in literature a communication about the respiratory movements with spiders. Anatomists have of course pronounced various hypotheses, but there is no necessity of discussing these here.

PLATEAU had discovered with certain spiders, the enlarged images of which he projected on a screen, very slight oscillatorical movements of the palps and the abdomen, but he did not deem them of any interest. I intend to explain in the first place the signification of these rythmical movements.

If we examine an *Epeira* that has previously been fastened at the thorax, under the microscope, we observe the following phenomena, the posterior point of the abdomen moves upward and downward with a rhythm of 130 movements a minute: they are slight oscillations which, though showing some diversity, are never smaller than $\frac{1}{50}$ millimeter. The entire abdomen takes part in this movement which forms in reality an oscillation round the peduncle of the abdomen.

The palps oscillate likewise in the same rhythm, and even every foot, in so far as its point stands free. the angles formed by two successive segments become alternately larger and smaller, and so the point moves, as if it beat the time of the rhythm.

One tries immediately to find the explanation of such phenomena in quick variations of the pressure of the blood, which would correspond with the systoles of the heart. The heart lies under opaque tissues; but we find on the feet some spots, the teguments of which are sufficiently transparent to enable us to observe through them the circulation of the blood; we perceive in the superficial parts of the organ, between the muscles, ramifications of the centripetal current, in which the blood-corpuscles push onward by saccades that are isochronal with the examined rhythm.

The contemplation of the structure of the blood-system (fig. 1) explains the cause of the phenomena we observed, and chiefly of the downward movement of the abdomen, when the heart contracts. I find two factors for it: 1. the tension of the curved aorta under the influence of the increased interior pressure; 2. another depending upon the pericardial cavity. during the systole of the heart the pressure of the blood in this cavity decreases, and consequently this curved tube assumes a greater curve.

¹⁾ F. PLATEAU. De l'absence de mouvements respiratoires perceptibles chez les Arachnides. Archives de biologie T. VII, 1887.

These two factors operate together on the parietes of the abdomen by means of the ligaments, and compel the abdomen to go downward; in my opinion the directions of the ligaments even indicate the lines along which the different partitions of the central blood-organ operate upon the teguments.

Fig. 1. *Epeira diadema*. On a sagittal section are represented inter alia: the heart and the pericardial space, the ramifications of the aorta into the cephalothorax, the three pair of abdominal arteries (a) and the posterior artery (ap), the "ligaments epicardiques" (1—11), some "ligaments commissuraux" (c) and "ligaments hypocardiques" (h).

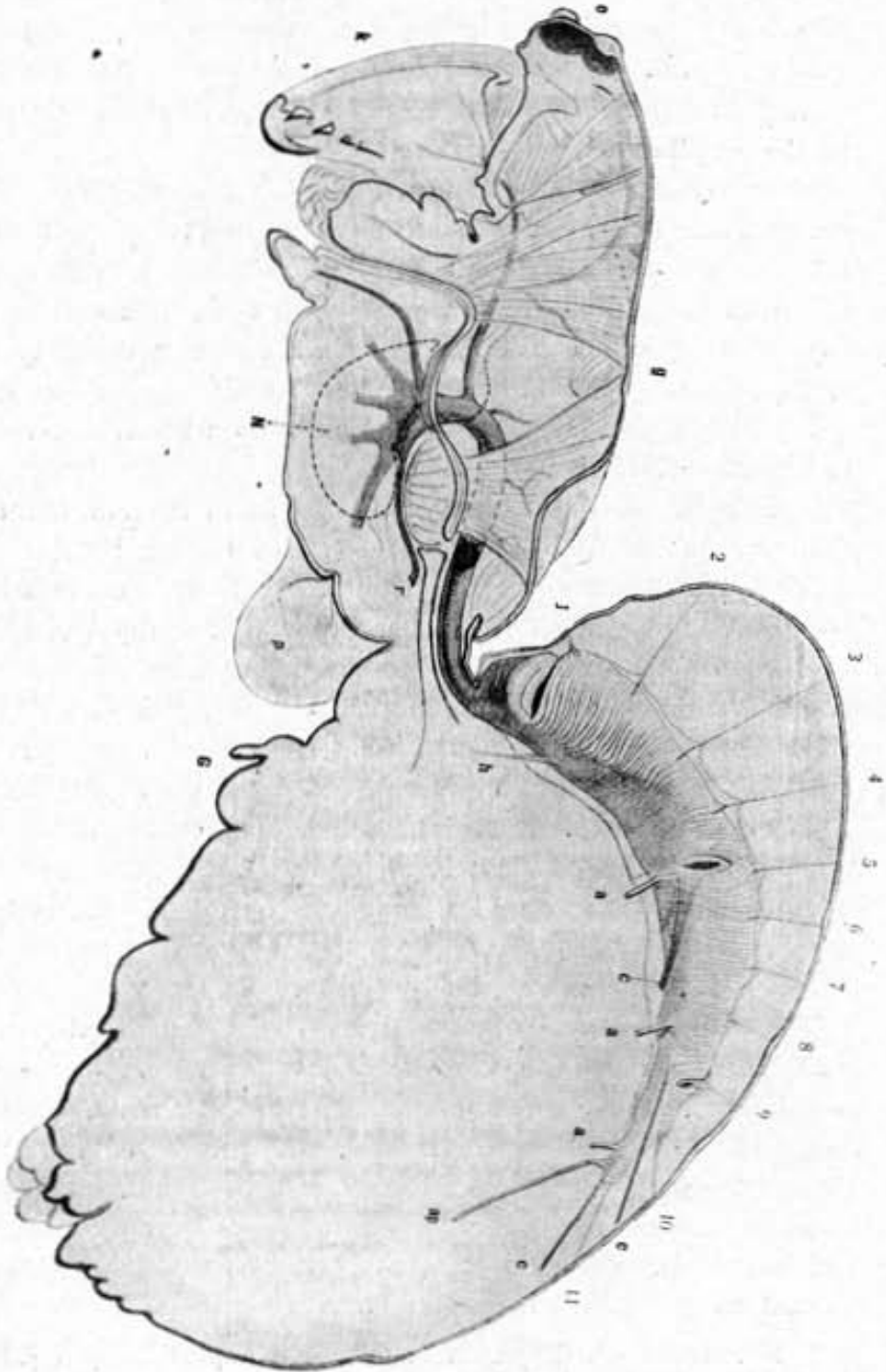

But the movements of the abdomen that accompany the systole of the heart, are more complicated.

1. A group of hairs on the central part of the back do not change place parallelly, as would be the case, if they simply took part in the general rotation of the abdomen; they make a rhythmical oscillating movement, which can only be the result of a special deformation of the field, on which they have been infixed. This deformation consists in a rhythmical descent of the part we had in view, corresponding with the descent of the entire abdomen. It is caused by a tension in the ligaments épocardiques (especially 3 to 9) which accompanies the systole of the most active part of the heart.

2. The region of the median dorsal line, lying quite frontal, just over the peduncle, is pushed forward about $\frac{1}{10}$ millimeter in a frontal direction at the beginning of every pulsation (when the abdomen descends): at the beginning of the general contraction of the heart-tube the motion of the blood causes there a tumefaction of the vessel of short duration.

3. The exterior wall of the lungs shows likewise very slight oscillations and descends to the interior at every systole: a phenomenon indicating a decrease of the pressure of the blood under this region.

This leads us to the study of the influence of the systoles of the heart on the contents of the lungs. I have been able to make a special study of this subject with another species of spider possessing transparent teguments, allowing us distinctly to observe some movements of the interior organs.

With *Pholcus phalangioides* one observes similar movements and variations of the shape of the abdomen as with *Epeira*, but these are still more complicated, because the teguments are more flexible, and correspond more to the local variations of the interior pressure; yet, I shall for the present moment not describe them more accurately.

A direct observation convinces us that the contraction of the heart causes a diminution of the pressure of the blood in the pericardial cavity and in the pulmonary vein: the laps of the "liver" surrounding these blood-cavities are seen to move inwardly at every systole, and the more violently, as the examined point lies nearer to the most active part of the heart.

The same phenomenon shows likewise a similar diminution of the pressure in the large blood-lacune in which the heart lies; consequently there exists a suction of the blood from the peripulmonary lacuna to the pulmonary vein, and likewise, which is of importance for the respiration, from the lacunes of the lamellas of the lung; a sufficient illumination allows us even to see, that, when a systole

takes place, the blood-corpuscles suddenly remove themselves from these lamellas. In consequence of this suction the thickness of the lamellas decreases, and the complex of the lamellas is seen to be

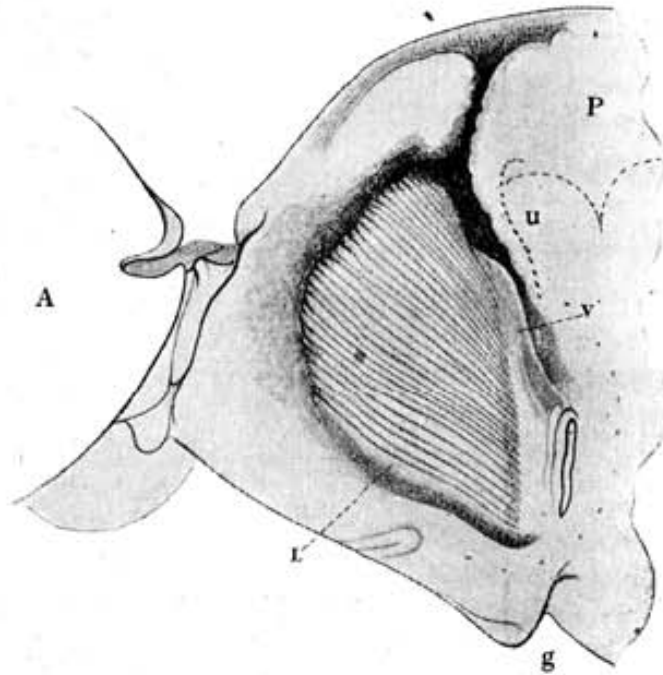

Fig. 2. *Pholcus phalangioides*. The left lung and the surrounding region seen from aside; one sees through the teguments the lung, the peripulmonary blood-lacune, the pulmonary vein (*u*). *P*, pericardial space; *c.*, superior wall of the vestibulum of the lung; *L*, inferior lamella of the lung; *g*, genital opening ♂; *A*, posterior part of the cephalothorax.

compressed (over about $\frac{1}{25}$ of its thickness) at every systole; as by their elasticity the lamellas resume their former volume at the end of the systole, the white mass seems to move like an accordion one side-wall of which would be fastened.

So we understand the circulation of the blood in the lungs; it is not a consequence of a general contraction of the pillar-cells, to which, with MAC LEOD, one was inclined to attribute a contractility of their own, but it is a passive consequence of the systole of the heart and the elasticity of the components.

Inhalation and exhalation can be explained in the same way from these phenomena. The blood-pressure of the peripulmonary lacuna which always surpasses the atmospheric pressure, keeps the air-cavities of the lungs and the cuticular products of the lamellas and of the vestibulum compressed. Through the variations of this pressure, caused by the palpitations of the heart, the air-cavities become alternately smaller and larger; consequently the elasticity of

the cuticular products of the lamellas is the intermediate factor of the movements of the air in the lungs.

I must however still add that in special circumstances some more important movements of inhalation and exhalation can be observed, which are brought about by the operations of muscles of the body and of a special muscle of the vestibulum. I intend to discuss these in a subsequent communication.

Physiology. — "*On the nature and progress of visual fatigue*".

By Dr. A. A. GRÜNBAUM (Odessa). (Communicated by Prof. G. VAN RIJNBEEK¹).

(Communicated in the meeting of May 27, 1916).

The problem of visual fatigue has, in contrast with cognate problems as those of light- and darkness-adaptation hardly been broached from an experimental side.

The widely spread, purely theoretical views have from one side contributed to this fact, according to which the self-regulation of optically sensitive substances leads to a practical indefatigability. (HERING). On the other hand the traditional postulate, according to which the application of very strong optical stimuli in itself lies already beyond the physiologic limits of the pathological domain, plays an important part in the neglect of our problem.

Notwithstanding this I have only been conducted by purely experimental requirements and consequently selected strong stimuli, causing a positive fatigue. A 400 N. K.-lamp e.g., tempered by a milk-glass and placed at a distance of 1.25 m. from the experimental person, forms such a stimulus.

I have studied the progress of the fatigue caused by this light-stimulus by availing myself of the already often investigated phenomena of "flickering".

When we cause a light-stimulus to influence, intermittingly with a dark pause, on the eye, we can at a definite frequency of the succeeding stimuli no longer distinguish them; the impressions fuse, and from the flickering light the impression of a relatively quiet light is experienced.

The number of light stimuli (and consequently likewise that of

¹) The results recorded here form part of a series of experiments made in the years 1914—16 in the Physiological Laboratory of the University of Amsterdam, serving to obtain the *venia legendi* in experimental psychology at the Medical Faculty there.

the intermissions) at which the impression of fusion becomes just noticeable does not only depend upon the intensity of the intermitting stimulus (SCHENK, MARBE and others), but also upon the functional condition prevailing in the visual organ. SCHATTERNIKOFF e. g. has found that the frequency at which the fusion sets in, diminishes not only with a stronger intensity of the intermitting light, but also with a stronger adaptation of obscurity.

Some introductory experiments have taught me, that likewise a previous strong stimulus of the eye with the strong source of light described above diminishes the frequency for the fusion. There is no doubt a certain connection between the measure of diminution of the limit value (Schwellenwert) and the duration of the penetration of the stimulus of fatigue. The limit value for the fusion (i. e. the number of interruptions at which it just sets in) can serve as a measure of the fatigue prevailing at the moment of the experiment.

As however the results of some authors who occupied themselves with the analogous limit values, differ very considerably, I intended to find the cause of this fact, and to avoid it in my own experiments.

In the first place the moments mentioned already in literature that can cause the differences in the limit values were carefully avoided in a special apparatus. A constant light of a NERNST lamp, placed far behind a row of milk-glasses, is periodically interrupted by a massive metal dull-black-polished turn-disc with 12 equally cut out sectors. Before the disc a white screen was placed with a little opening fitting to the sectors. The illumination of the screen is always kept constant with the intensity of the light of the flickering hole.¹⁾ Further a maximum exercise of the experimental person is reached, and at last the relation is sought, at which the judgment of the experimental person is most stable.

It appeared that the experimental person must not wait during the experiment till the impression of an ideal rest within the visual field is reached, but must cease at a nearly imperceptible unrest within the optical field, as soon as this impression no longer changes with the further augmentation of the velocity of interruption. In reality the number of the interruptions per second at which the fusion takes place, is not taken into consideration as limit value. The most positive limit value corresponds much more with the number of interruptions at which only the distinction of the separate stimuli is no longer possible.

¹⁾ The mechanism for the regular modification of the revolving-velocity and likewise a number of little cautions for the stability of the exterior conditions I describe in an elaborate publication.

The corresponding method by which the limit value is reached through a slow increase of the velocity of intermission, furnishes especially a stable value at a continuous and regular approach of the limit value. The average variations, when this method was applied, were in our experiments less than one period (the duration of one light-stimulus + an equally long absolute dark pause) per second.

(I draw attention to the fact, that these results, forming a methodical foundation, are in a certain contradiction to the usual indications of application which are spread in the practice of heterochromal flickerphotometry.)

The constancy of the determinations obtained with our method renders it possible, that one single determination is sufficient to characterise the momentary condition of the visual apparatus.

The single determinations succeeding one another can consequently serve to construe an illustration of the variations of this condition during the time of the determinations.

When applying other psychophysical methods I have found however, that the limit values in the same objective circumstances, in the same series of experiments are, at great variance with each other. When comparing different psychophysical methods I have further discovered, that the limit values found do not only vary according to the methods applied, but that the deviation becomes the greater as the intensity of the flickering light increases. This proves consequently that the difference of the psychophysical methods is not only connected with a difference of subjective factors, but also with a preponderating modification of objective physiological conditions.

The difference in the results of the few authors who have experimented with quite different methods, is consequently to be explained in the first place by the influence of these different physiological circumstances. With all succeeding experiments I have therefore always applied the same method, which may be called: the method of the uninterrupted, regular increase of the velocity of intermission till an optical impression that does not change any more is reached.

By applying this method, I have tried inter alia to solve the question whether the adaptation of light can be regarded as a state of relative fatigue.

For this purpose two series of limit values are compared; one consisting of determinations that were noted after a good adaptation of light (15 min. in the sun), the second series, those which were noted after a fatigue of the eye.

It appeared that the state of the visual organ adapted to the

light remained constant in the successive determinations of the limits. With the experimental person W. a. e. g. the limit value, that is to say at little, respectively average, or great brightness of the flickering light it was 28.6 respectively 23 or 20 periods per second.

After the penetration of the strong light-stimulus during 45" respectively 90" or 180" the successive determinations which were each separated from each other by rest-pauses of 10 seconds and lasted even about 15 seconds, offered quite a different appearance.

I summarise the progress of the effect of the fatigue in Table 1.

This table teaches:

1. The longer the fatigue lasts, the more the power of distinction decreases in the first moment after the cessation of the stimulus of fatigue.

2. The norm, which the achievement indicates at a good adaptation of light, is however reached in about the same time. So the longer the fatigue lasts, the more relatively the process of relaxation takes place.

3. After the norm has been reached again, the power of prestation rises still higher above the norm and remains for some time so much the greater as the primary fatigue was longer.

This excess of compensation deserves our special attention.

4. The greater the intensity of the flickering light is, the less the prestation descends under the corresponding norm with the same duration of the stimulus of fatigue.

Point 1 indicates how the processes of fatigue constantly prevail more and more over the compensatory factors intervening simultaneously, when the duration of the irritation is increased.

In point 2 the regulations of the efforts of the fatigue are formulated by the compensatory processes after the cessation of the stimulus of fatigue.

Point 3 indicates the relative duration of these compensatory processes after the relaxation has taken place.

Point 4 indicates that the consequences of the fatigue do not only depend upon the duration of the fatigue, but also upon the original stationary condition of the eye that is caused by the intensity of the flickering light.

The comparison of the limit values after the fatigue and after the adaptation of light shows consequently a principal difference between the two states. The adaptation of light is a stationary state of the eye which determines a constant height of the prestation. When this state has once been reached, then it is indifferent with regard to the time-factor. The fatigue on the contrary creates a

TABLE I. Binocular fatigue

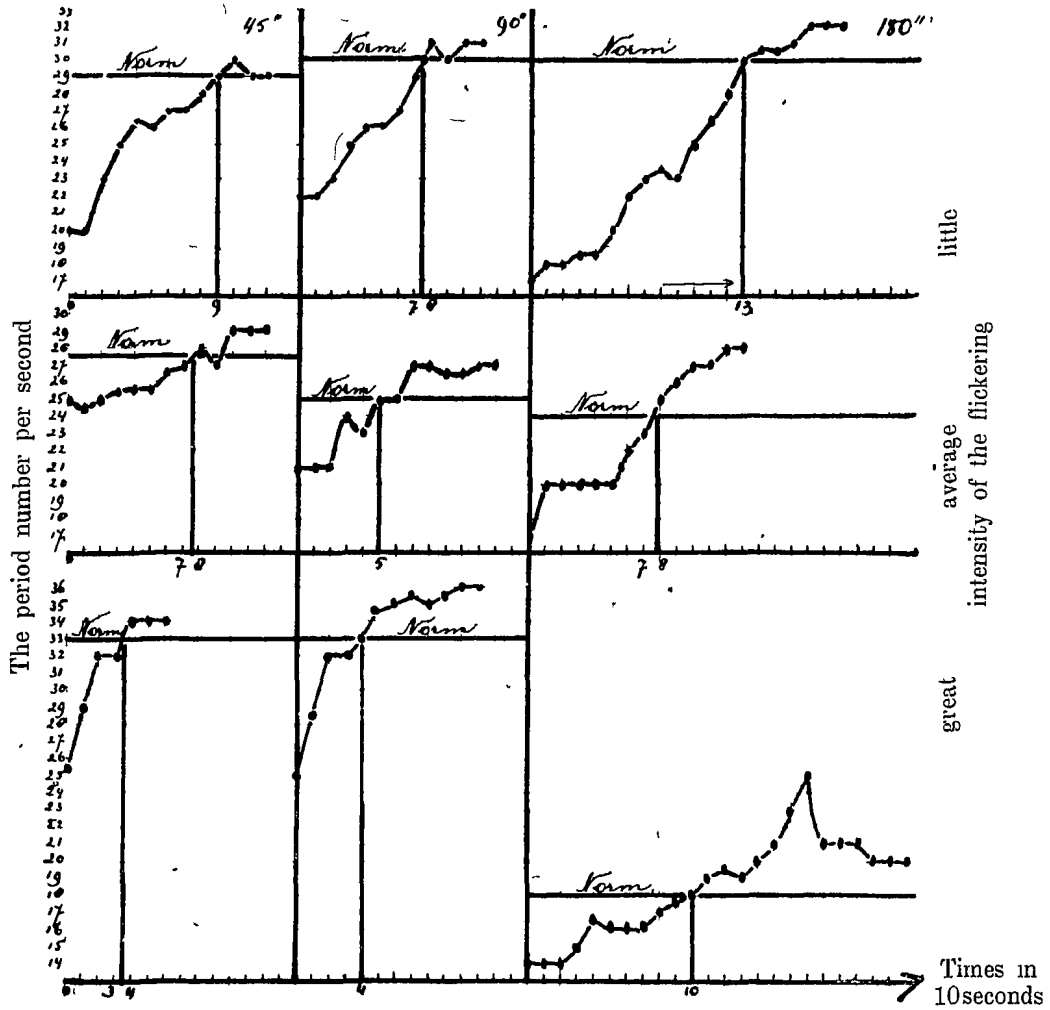

process, or in better words, a modification of state, consisting of two antagonistical moments, which are dependent on the time-factor according to fixed laws.

From the controlling experiments, in which a constant width of the pupils had been obtained, follows, that the modification of the limit values represented in our curves cannot be attributed to a modification of the quantity of the light, which is connected with the reflectoric narrowing and gradually widening of the pupils at the strong irritation. The modification of the brightness of the surroundings of the flickering plane is likewise without influence. (This modification is always caused by the intensive gradually disappearing after-images of the stimulus of fatigue). The corresponding control has, namely, shown that in one and the same series of experiments

1st equal limit values can be obtained both when the after-images are still extant and when they have afterwards disappeared. 2^{ly} Two succeeding limit values can also indicate a regular increase of the prestation, when the same subjective intensity of the after-images is stated. 3^{ly} The weakening or strengthening of the subjective intensity of the visible after-images (reached by means of an adequate modification of the illumination of the screen round the flickering hole) remains without influence on the shape of the curve.

From the comprehensive problem of the nature of visual fatigue it appeared to me, that, for a concrete experimental answer, in the first place the question must be solved: where is the place of the processes of fatigue? Is it peripheral, central or both? In order to approximate the answer I have applied the following method. Two progress curves obtained by monocular determinations at the same eye are compared together. In one series the same eye is fatigued, on which the determinations of the limit value are executed (direct penetration), in the other series on the contrary the stimulus of fatigue on the other eye (consensual penetration).

The experiments applied under constant adaptation of the not fatigued eye showed the image represented in table II (p. 173).

The results can be summarised in the following rules:

1. *There exists a consensual fatigue of the eye.*
2. The first occurring decrease of the prestation is greater at the direct fatigue than at the consensual one. In the examined limits of the intensities of the light this relation depends neither on the brightness of the flickering hole nor on the duration of the fatigue.
3. At the direct fatigue the norm is generally reached a little later than at the consensual penetration.
4. Up to the norm the curves have a tolerably equal process.
5. Then however the essential difference appears, that the direct fatigue causes the well-known over-compensation, which did not occur with the consensual irritation in the examined limits.

Points 2 and 3 may be summarised in the thesis, that the direct irritation of the eye causes greater fatigue than the consensual one. The explanation of this fact might be found in the self-evident circumstance, that in the case of the consensual penetration there is only a central component of the fatigue extant, whilst at the direct irritation there is still the dissolution (kataboly) of the substances, that are lying in the irritated eye itself, i.e. peripherally.

With this hypothesis of two components of the visual fatigue point 5 can be interpreted as follows. The results of the over-compensation are in the first place characteristic of the restitution of

the peripheral sensitive substances, because this over-compensation has only taken place at the direct irritation. It stands to reason, that it still remains the question, if at less

The period-number of the sec. in which the fusion-impression changes no longer

TABLE II. M Monocular D (direct) and K (consensual) fatigue during:

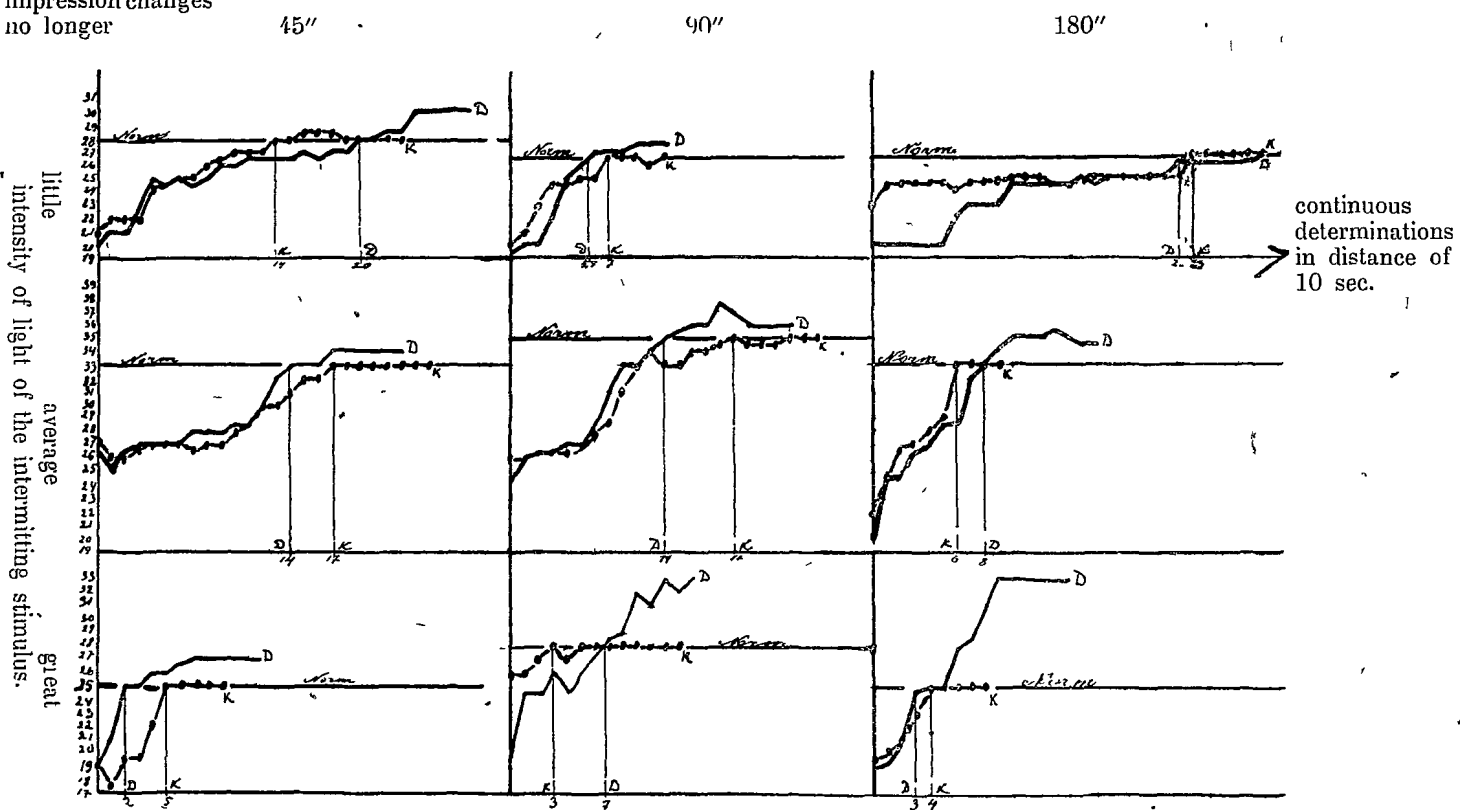

important intensities of fatigue the direct irritation does not likewise cause over-compensation, and if at greater intensities, on the contrary the consensual irritation cannot likewise bring about such effects.

At the end we should compare the corresponding progress curves with the direct binocular and direct monocular penetration. We can, when doing so, sum up the deeper decrease of the limit values under the norm, the ulterior reaching of this norm and their afterwards coming higher above the norm, as a symptom of greater fatigue. The contemplation of table III added here teaches as follows:

TABLE III. Comparison of the results of the binocular and the monocular irritation of fatigue.

	Intensity of the irritating light	Duration of the Fatigue.			in general
		45"	90"	180"	
Deeper under the norm	little	B	B	B	M
	average	M	M	M	
	great	B	M	M	
Higher over-compensation	little	M	=	B	=
	average	B	B	B	
	great	M	M	M	
Norm reached afterwards	little	M	B	M	M
	average	M	M	M	
	great	B	M	B	

B - Binocular Irritation
M - Monocular of fatigue

In our determinations the monocular irritation relatively brings about somewhat greater effects of fatigue than the binocular one. At all events the binocular irritation is not accompanied by greater effects than the monocular one. Consequently there does not exist a binocular summation of the irritation of the visual fatigue, which corresponds well with the analogous denial of the binocular summation of the subjective brightnesses (ROELOFS and ZEEMAN).

Chemistry. — “*The system Iron-Carbon-Oxygen*”. By Prof. W. REINDERS. (Communicated by Prof. J. BÖSEKEN).

(Communicated in the meeting of May 27, 1916)

In two previous communications¹⁾ it has been shown what dissociation equilibria in a few ternary systems metal-sulphur-oxygen may be thought possible and the result has been given of the investigations that have decided which equilibria are really stable. In a similar manner the dissociation equilibria in the systems metal-carbon-oxygen may now also be treated. Without entering into the discussion of the numerous possibilities that are conceivable according to the nature of the metal we will treat in the following the equilibria to be expected with a single metal, namely iron. Similar considerations apply *mutatis mutandis* also to other metals.

The ternary system Fe—C—O is based on 3 binary systems, namely C—O, Fe—O and Fe—C.

The first has already been studied in 1864 by ST. CLAIRE DEVILLE²⁾ and later by BOUDOUARD³⁾, MAYER and JACOBY⁴⁾, RHEAD and WHEELER⁵⁾ in a more accurate manner. The proportion of the two oxides CO and CO₂ in a gaseous mixture in equilibrium with carbon is consequently now known with a fairly great certainty.

The stable oxides of iron are Fe₂O₃, Fe₃O₄ and FeO. The first two form certainly phases apart. Between Fe₃O₄ and FeO, however, a mixing in the solid condition might be possible, according to a more recent research of HILPERT and BEYER⁶⁾. We will disregard this possibility, which has found no confirmation during the investigations in the ternary system with carbon⁷⁾.

As to the system iron-carbon a number of papers have appeared, ever since 1900 when BAKHUIS ROOZEBOOM⁸⁾ published his views

¹⁾ W. REINDERS, Equilibria in the system Pb—S—O. Proc. **17**, 703 (1914) and W. REINDERS and F. GOUDRIAAN, Equilibria in the system Cu—S—O. Proc. **18**, 150 (1915).

²⁾ C. R. **59**, 873 (1864).

³⁾ Ann. d. chim. et d. phys. (7) **24**, 1 (1901).

⁴⁾ Journ. f. Gasbeleuchtung **52**, 1909.

⁵⁾ Journ. Chem. Soc. **97**, 2178; **99**, 1140 (1911).

⁶⁾ Ber. d. D. chem. Ges. **44**, 1608 (1911).

⁷⁾ See, for instance V. FALCKE, Z. f. Elektrochem. **22**, 121 (1916).

⁸⁾ Z. f. physik. Chem. **34**, 437 (1910).

thereon and gave the first comprehensive melting point diagram, without, however, a complete unanimity of opinion being attained. There has been a difference of opinion particularly as to the question whether iron carbide Fe_3C is a stable or more likely a metastable compound. BAKHUIS ROOZEMBOOM took it to be stable below 1000° and in agreement therewith E. D. CAMPBELL¹⁾ found by means of thermic determinations a positive heat of formation. CHARPY, BENEDICKS and others have, however, argued that cementite must be metastable, which conclusion is confirmed by the experiments of ROYSTON²⁾. Moreover the subsequent measurements of RUFF and GERSTEN³⁾

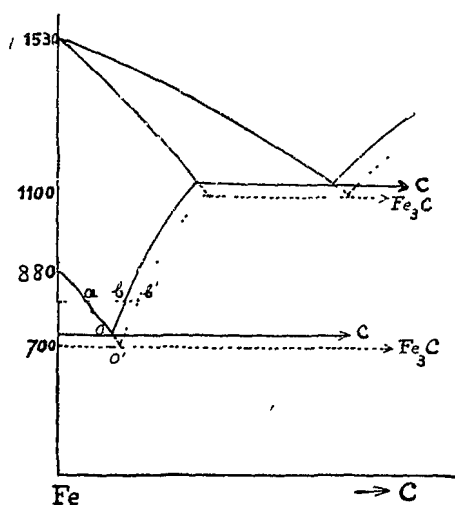

Fig. 1.

have taught us that Fe_3C is endothermic (-15.1 cal.). Hence, we may assume with a fair degree of certainty that the solid phase Fe_3C is metastable in regard to iron and graphite and probably also in regard to iron and amorphous carbon. In Fig. 1 we thus have the diagram of condition. In many changes in condition, however, such as in a not exceedingly slow cooling, the carbide (cementite) is often formed instead of graphite + iron which, once it is formed, passes but exceedingly slowly into the stable phases⁴⁾.

In considering the ternary system we will, therefore, have to take into account the possibility of formation of Fe_3C .

The isotherms for temperatures below 700° .

The equilibria in the ternary system at constant temperature may — as it has been done with the systems metal-sulphur-oxygen⁵⁾ — be represented in an equilateral triangle of which Fe, C and O are the apexes.

Below 700° martensite, the solid solution of carbon in iron, is not yet stable. Carbon and iron are thus in equilibrium with each

¹⁾ Journ. Iron and Steel Institute **59**, 217 (1901).

²⁾ Journ. Iron and Steel Institute **1**, 166 (1897).

³⁾ Ber. d. D. chem. Ges. **45**, 63 (1912).

⁴⁾ Also see A. SMITS Z. f. Elektrochemie **18**, 51 (1912).

⁵⁾ REINDERS and REINDERS and GOUDRIAAN, l. c.

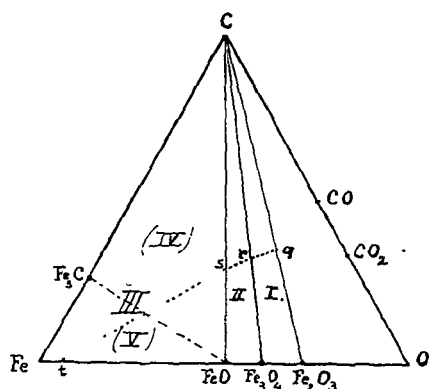
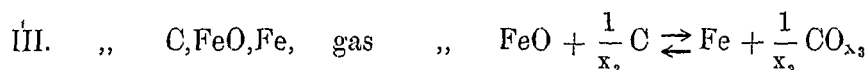
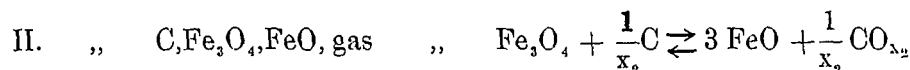
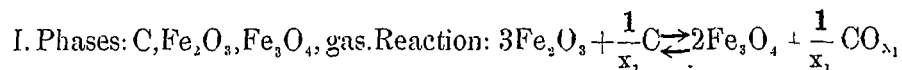
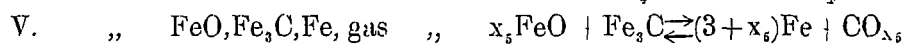
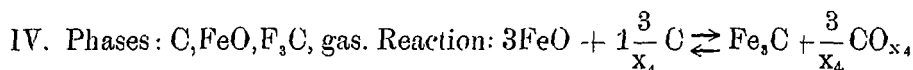

Fig 2.

If we start from a mixture of C and Fe_2O_3 of the composition q , on withdrawal of gas, these monovariant equilibria will be attained in the order I, II, III, where the composition of the solid phases mixture changes in the direction $q-r-s-t$ and the following reactions take place (the empirical composition of the gaseous phase to be taken as CO_x):



In addition, with the metastable carbide as participating phase, other metastable equilibria may be thought possible, of which the principal ones are ¹⁾:



These monovariant equilibria are to be considered as the limits within which the following divariant equilibria are stable:

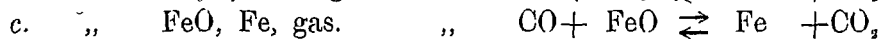
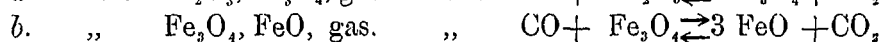
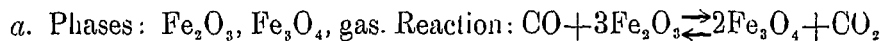

¹⁾ It might also be possible that after the equilibrium I followed at once an equilibrium with Fe_3C , hence between the phases Fe_3O_4 , C, Fe_3C and gas, then the equilibrium between the phases Fe_3C , Fe_3O_4 , FeO and gas and finally that between Fe_3C , FeO, Fe and gas. It would, however, lead us too far to discuss all these eventualities separately.

Metastable are the equilibria:

- e.* Phases: FeO, Fe₃C, gas. Reaction: $3\text{FeO} + 5\text{CO} \rightleftharpoons \text{Fe}_3\text{C} + 4\text{CO}_2$
f. „ Fe₃C, Fe, gas. „ $\text{Fe}_3\text{C} + \text{CO}_2 \rightleftharpoons 3\text{Fe} + \text{CO}$.

According to the law of mass action, when the gas consists of x mols. of CO and $(1-x)$ mol. of CO₂ and when P is the total pressure, the following relations should apply to these equilibria:

$$a. \quad \frac{p_{\text{CO}}}{p_{\text{CO}_2}} = \frac{x}{1-x} = k_a$$

$$b. \quad \frac{p_{\text{CO}}}{p_{\text{CO}_2}} = \frac{x}{1-x} = k_b$$

$$c. \quad \frac{p_{\text{CO}}}{p_{\text{CO}_2}} = \frac{x}{1-x} = k_c$$

$$d. \quad \frac{p^2_{\text{CO}}}{p_{\text{CO}_2}} = \frac{x^2}{1-x} \quad P = k_d$$

$$e. \quad \frac{p^5_{\text{CO}}}{p^4_{\text{CO}_2}} = \frac{x^5}{(1-x)^4} \quad P = k_e$$

$$f. \quad \frac{p^2_{\text{CO}}}{p_{\text{CO}_2}} = \frac{x^2}{1-x} \quad P = k_f$$

If in accordance with R. SCHENCK¹⁾ we represent the relation between x and P graphically there are formed a series of lines as indicated in Fig. 3.

The lines a , b and c are straight; in these equilibria x is independent of the pressure. The lines d and f are cubic hyperboles and e is a similar curved line of higher degree.

The monovariant equilibria are now found as points of intersection of these lines, namely I , II and III as points of intersection of a , b or c with d , IV as point of intersection of d and e and V as that of c , f and e .

The equilibria IV and V are metastable because this is the case with one of the participating phases, Fe₃C. From this it may be directly concluded that V must lie above III and IV below the same. As V and III are both situated on the line c the composition of the gaseous phase for these equilibria is the same. When now this gaseous phase comes alternately in contact with the solid

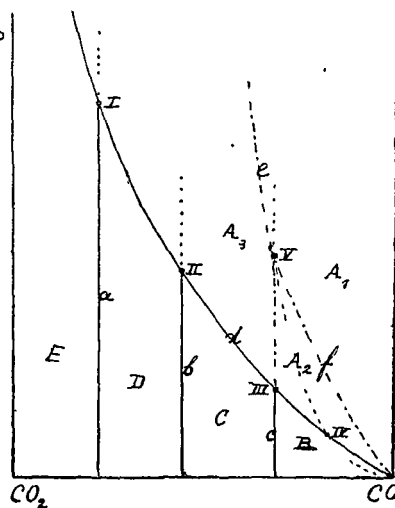
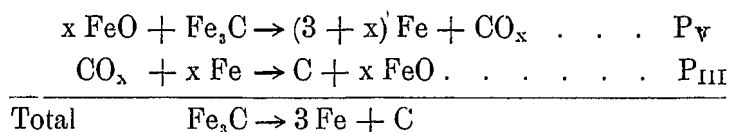

Fig. 3.

¹⁾ R. SCHENCK, Zeit. angew. Chem. 17, 1077 (1904); Z. f. Elektroch. 15, 584 (1901); Physikalische Chemie der Metalle, Halle a. S. (1908).

phases of *V* and of *III* the metastable carbide will have to disappear by the following transformations:



These transformations, however, only then take place in the sense indicated above if $P_V > P_{III}$.

The situation of the points *V*, *IV* and *III* in regard to each other must, therefore, be that indicated in Fig. 3.

From the equilibria indicated by the lines *a*, *b*, *c* etc. we can deduce the reactions that take place at the left and the right of these lines and from this find the phases that are stable in the different fields of Fig. 3.

From this it appears that the carbon is only stable with gaseous mixtures from the region *A* at the right of *d*; at the left of *d* *A* reacts with the carbon dioxide with CO-formation, until the composition of the gas is so far modified that it can be indicated by a point of the line *d*.

In the region *E* only Fe_2O_3 is stable, in *D* Fe_3O_4 , in *C* FeO and in *B* Fe .

In the point *V* the 3 lines *c*, *f* and *e* meet and separate from each other 3 regions, a first one *A*₁ where Fe_3C should be stable, a second one *A*₂ where Fe and a third one *A*₃ where FeO should be stable. Hence, the line *e* should be stable only from *V* to the region of higher pressures, the lines *c* and *f* only from *V* to lower pressures.

The equilibria around the point *V* are however, all metastable in regard to the carbon because all CO-concentrations to the right of *d* are metastable. Above the line *d* only C and one or two of the solid phases Fe_2O_3 , Fe_3O_4 , FeO or Fe are stable and the gaseous phase is metastable.

If now we start from a mixture of Fe_2O_3 and C of the total composition *q* (Fig. 2) and lower, at a constant temperature, the pressure above, gas will form of the composition *I* when the pressure *I* (Fig. 3) is attained. If this gas is removed by suction the monovariant equilibrium *I* is retained so long as Fe_2O_3 is still present. The composition of the ferric oxide-carbon-mixture there changes from *q* to *r* (Fig. 2). When all the Fe_2O_3 is used up, the pressure of the divariant equilibrium Fe_3O_4 , C , gas changes according to the line *I—II* until at this last pressure the reduction to FeO sets in and when more gas is withdrawn, the pressure remains constant;

12*

the composition of the solid-phase mixture then changes from r to s . Subsequently, in the monovariant equilibrium *III*, the composition changes from s to t so that finally a mixture of Fe and FeO remains. If the original mixture q had been a little richer in carbon a mixture of Fe + C might have been left behind at the termination.

Conversely, by interaction of a gaseous mixture of CO + CO₂ on iron at a sufficient pressure, this gas will be absorbed with separation of C and formation of iron oxides and in succession the equilibrium *III*, *II* and *I* can be attained.

The isotherm for temperatures between 880° and 1100°.

At these temperatures iron forms with carbon solid solutions, *martensite*, of which the C-content varies from 0 to about 2%. The projection of the spacial isotherm on the x-plane then becomes as indicated in Fig. 4.

After the 2 monovariant equilibria *I* and *II* now follows *VI* between FeO, C and the C-saturated solid solution a . After this comes the divariant equilibrium between FeO, the unsaturated solid solutions

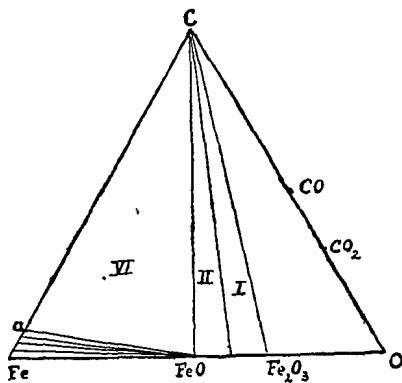

Fig. 4.

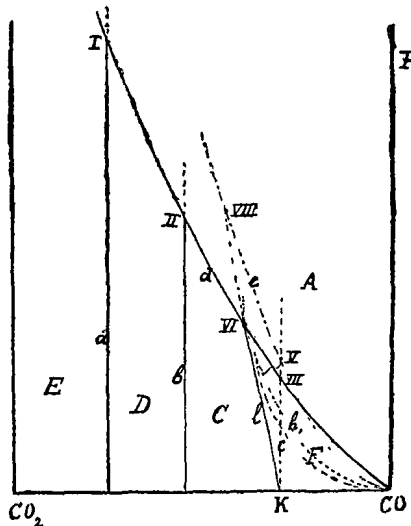
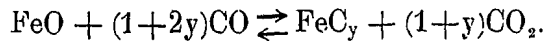

Fig. 5.

and the gaseous phase. The carbon content of the unsaturated solutions can vary from a to 0. If we represent the empirical composition of these solutions by the formula FeC _{y} , the reaction, applying to the divariant equilibria between FeC _{y} and gas, will be represented by h .



For this equilibrium exists the relation

$$\frac{p_{\text{CO}}^{1+2y}}{p_{\text{CO}_2}^{1+y}} = \frac{x^{1+2y}}{(1-x)^{1+y}} \cdot P^y = \text{constant},$$

if x indicates the part CO in the gaseous mixture of CO + CO₂, hence

$$\frac{x^{\frac{1}{y}+2}}{(1-x)^{\frac{1}{y}+1}} \cdot P = k_h.$$

The graphic representation of this relation is again a similar curve as line e and — as y will be usually small, therefore $\frac{1}{y}$ large — of a very high degree.

The limits, between which y can vary, is on the one side the value of the saturated solution α , on the other side 0.

In this latter case the above relation passes into the equation; $\frac{x}{1-x} = k_c$, that is the relation for the reaction $\text{FeO} + \text{CO} \rightleftharpoons \text{Fe} + \text{CO}_2$, which in Fig. 5 is indicated by the straight c .

The lines indicating the equilibria of the different solid solutions FeC_y , each with FeO and the gaseous phase, thus form a collection of curves of increasing higher order the latter of which, for $y = 0$, passes into the straight line c .

The first, relating to the solid solution saturated with carbon is indicated by the line h_1 . The point of intersection of this line with the line d gives the monovariant equilibrium VI.

The points of intersection of the other lines h with the line d , also the point of intersection of c with d (III) are metastable equilibria because they relate to solid solutions unsaturated with carbon. They are, therefore, situated at the right from VI, between VI and III.

Below VI the successive curves cut each other and the envelope l formed by these intersections now forms the equilibrium line of FeO with the different unsaturated solid solutions. It runs from VI (equilibrium of the saturated solution) to K (equilibrium with pure Fe).

From VI, the monovariant equilibrium between C, FeC_y , FeO and gas, thus run 3 lines of divariant equilibrium, namely

- d , between II and VI for the phases C, FeO and gas.
- d , „ VI and CO „ „ „ C, solid solution and gas.
- l , „ VI and K „ „ „ FeO, solid solution and gas.

They enclose in the planes

F where are stable solid solutions + gas.

C „ „ „ FeO + gas.

A „ „ „ C + solid solutions (pressure $< p_{VI}$).

or C + FeO (pressure $> p_{VI}$ and $< p_{II}$)

whilst in both cases the gaseous phase is metastable.

When instead of the stable carbon the metastable Fe_3C occurs, metastable equilibria are formed in the field A . The line l does not then terminate already in VI, but ends in the point VIII where it cuts the line e and where there is consequently monovariant equilibrium between FeO , Fe_3C , FeC_y and gas. The region of the mixed crystals F thus becomes larger also and is limited on the one side by the line l , on the other side by a cubic hyperbole m , which passes through CO and VIII and indicates the equilibrium of the reaction

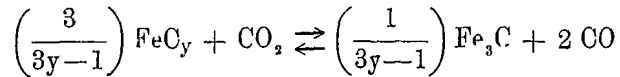

hence,

$$\frac{p^2 \text{CO}}{p \text{CO}_2} = \frac{a^2}{1-a} P = k_m$$

To the right of this line Fe_3C is then stable.

The isotherm for temperatures between 700° and 880°.

Whereas above 880° all mixed crystals from pure iron to the ones most rich in carbon are stable, this is no longer the case below 880°. Those poor in carbon become metastable and only those whose composition is situated between two limits — indicated in Fig. 1 by the letters a and b are stable.

Hence, the isotherm gives 4 monovariant equilibria, namely:

- I. Fe_2O_3 , Fe_3O_4 , C and gas
- II. Fe_3O_4 , FeO , C and gas
- VI. FeO , $(\text{FeC}_y)_b$, C and gas
- VII. FeO , $(\text{FeC}_y)_a$, Fe and gas.

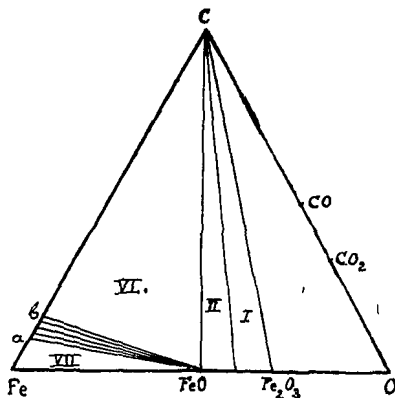

Fig 6

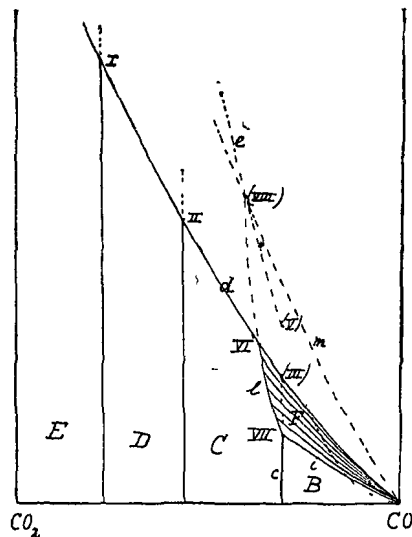
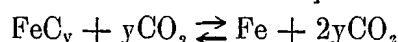

Fig. 7.

Between VI and VII is situated the region of the divariant equilibria of FeO with mixed crystals a to b .

The p - x -diagram (Fig. 7) much resembles that for temperatures above 880° (Fig. 5) with this difference, however, that the line l is not stable as far as the foot of the line c , but only as far as VII, where it cuts the line c . Below this point of intersection, the line c , the equilibrium FeO—Fe, becomes stable.

Below the stability region of the mixed crystals F thus appears a region for pure iron, B. The demarcation between the regions is given by the line i which indicates the equilibrium



to which applies the relation:

$$\frac{p^2 \text{CO}}{p \text{CO}_2} = \frac{x^2}{1-x} P = k_i$$

The line i is, therefore, like d and m an ordinary cubic hyperbole of which the parameter k_i changes with the temperature in that sense that it becomes nought at 880° (the isolated region B disappears) and equal to k_d at $\pm 700^\circ$ (the region F where the mixed crystals are stable disappears).

The metastable equilibria, in case Fe_3C does not separate instead of carbon, are analogous to those for temperatures above 880° . Instead of VI we thus obtain the equilibrium VIII and a demarcation of the mixed-crystal region not by the line d but by m .

Influence of the temperature; the p - T -lines.

An increase of the temperature causes the equilibrium to shift very strongly to the right. The constant k_d of the reaction thus becomes greater and the line d much steeper.

The temperature has comparatively little influence on the equilibria of the iron oxides with CO and CO_2 .¹⁾ The consequence is that the points of intersection I, II and III, which indicate the pressures of the different monovariant equilibria, strongly rise with the temperature. The lines indicating this relation have a similar course as the well known dissociation lines for hydrated salts, carbonates etc. They also can, as referring to the monovariant equilibrium between a gaseous and 3 solid phases of constant composition, be represented by the equation:

$$\log p = -\frac{A}{T} + B.$$

¹⁾ BAUR and GLAESSNER, Zeitschr. f. physik. Ch. **43**, 354 (1903).

IX between the phases Fe, FeC_y, C and gas
and X „ „ „ Fe, FeC_y, C, FeO

As these ternary equilibria are subordinate to the binary equilibrium between Fe, FeC_y and C and as this alters but very little with the pressure, the equilibria IX and X will also be almost independent of the pressure.

Beside the stable quintuple point O with C as a participating phase there also exists a metastable quintuple point O', in which, instead of carbon, Fe₃C participates and where V and VIII come in contact with the prolongation of VII.

Of these different lines II has been determined experimentally by R. SCHENCK and V. FALCKE¹⁾ and the line III by different investigators and that repeatedly²⁾. The equilibria always set in but exceedingly slowly and are, as is to be expected, dependent on the kind of carbon that is used. With graphite are obtained lower pressures than with amorphous carbon. Looking at the fairly concordant results obtained by the different investigators we find, with graphite 680° as the temperature where p_{III} becomes = 1 atm.

O' is situated at about 700° and O therefore certainly above 700°. From this it follows that the pressure in the quintuple points will be greater than 1 atmosphere.

As to the other lines of Fig. 8 nothing is known with certainty. I probably lies at such low temperatures that the reaction velocity is too small to obtain stable equilibria; VI and VII will lie at pressures > 1 atm.; V and VII, however should, without great trouble, be accessible to the experiment. As to V, some indications are to be found in the different experiments. SCHENCK³⁾ observed that on interaction of much CO with comparatively little iron there was formed a lower equilibrium pressure and a CO-richer equilibrium gas than on the interaction of little CO with much iron. He supposed that in the first case the equilibrium IV between Fe₃C, FeO, amorphous C and gas is obtained and then calculates from the relation: CO:CO₂ and the value of k_c that for the equilibrium V at 650° $p = 51.92$ atm., at 700° $p = 166.3$ atm.

A priori, this assumption and the conclusion drawn therefrom is not very acceptable. As shown from Fig. 3, the equilibrium IV, as the intersecting point of *d* with *e*, which at that place is doubly

¹⁾ Ber. d. Deutsch. chem. Ges. **40**, 1708 (1907).

²⁾ SCHENCK, SEMILLER and FALCKE, Ber. **40**, 1704 (1907); VAN ROYEN, Dissertation, Bonn 1911, H. NIPPERT, Dissertation, Breslau 1913; V. FALCKE, Z. f. Elektroch. **21**, 37 (1915); **22**, 121 (1916).

³⁾ R. SCHENCK, H. SEMILLER and V. FALCKE, Ber. d. D. chem. Ges. **40**, 1710 (1907).

metastable, is very little stable. Also an equilibrium of Fe_3C with C, which is founded on IV has never been observed. Moreover the assumption implies that a stable equilibrium already formed by a short interaction of CO with Fe would on prolonged action of CO pass into another equilibrium metastable towards the first and exhibiting a lower equilibrium pressure. This is contrary to the ideas of stable and metastable.

The later researches of FALCKE¹⁾ have indeed but partly confirmed these first observations of SCHENCK and his co-workers. It was confirmed that on short interaction of CO with Fe a solid phase mixture was obtained that on heating in vacuum yields higher pressures than the mass formed by prolonged interaction of CO with Fe. The first pressures measured at different temperatures give a p - T -line situated at about 10 – 12° lower than the second one, whereas the latter gets very close to that of the equilibrium FeO, Fe, graphite, gas. As to the composition of the gas, it appeared, however, that this in both cases does not materially differ and, according to the temperature, varies from 52 – 61% .

Moreover, FALCKE remarks that the first reaction product yields with HCl plainly hydrocarbons and leaves no residual carbon, whereas the iron carbonised for a long time with CO yields little or no hydrocarbons and leaves much carbon. Also HILBERT and DIECKMANN²⁾ found that on heating ferric oxide in a current of carbon monoxide at temperatures from 720 – 800° , free carbon did not form until the preparation had taken up 6% of C (Fe_3C contains 6.6% C.) and was completely reduced.

Hence it looks to me very probable that the higher pressures yielded by the iron carbonised for a short time, relate to the metastable equilibrium V (FeO, Fe, Fe_3C , gas) and the lower pressures to the equilibrium III (FeO, Fe, carbon, gas).

The projection of the four-phase lines on the T - x -plane.

The change in the relation $\text{CO} : \text{CO}_2$ with the temperature in the different equilibria is schematically indicated by Fig. 9.

Of this the line III between 600° and 700° has been determined experimentally³⁾; the proportion $\frac{\text{CO}}{\text{CO} + \text{CO}_2}$ varies from 52 to 61 .

Of the line III SCHENCK and FALCKE announce the pressure but not

¹⁾ l. c.

²⁾ Ber. d. Deutsch. chem. Ges. **8**, 1281.

³⁾ SCHENCK and co-workers and FALCKE l. c.

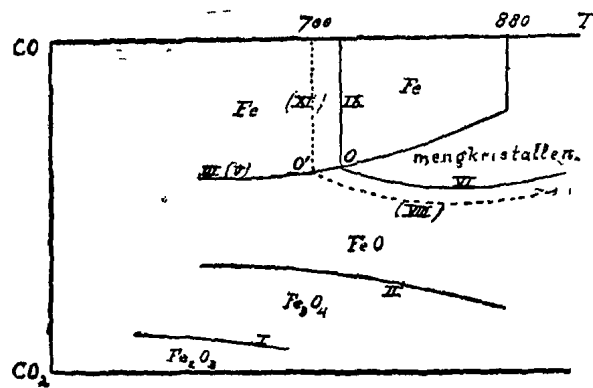

Fig. 9.

the proportion $\text{CO}:\text{CO}_2$ ¹⁾. As to the other lines nothing is known.

The equilibria at constant pressure.

Of particular importance is also the progressive change of the different divariant equilibria with the temperature at a constant pressure. They form as it were the section \perp the p-axis of the spacial p-T-x-Figure. In the case that this constant pressure is smaller than the pressure of the quintuple point O, for instance as p_1 in Fig. 8, this section becomes such as schematically represented in Fig. 10. Where on page 12 it is demonstrated that the quintuple point pressure exceeds 1 atmosphere, Fig. 10 thus also relates to 1 atm. pressure.¹

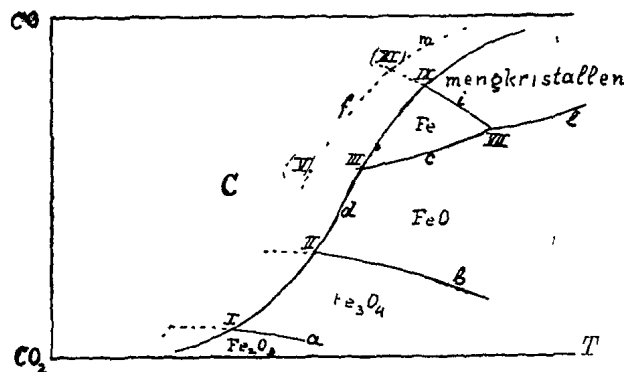

Fig. 10.

The divariant equilibria *a*, *b*, *c* reappear in this Fig. as lines enclosing the fields where the different solid phases are stable.

The lines *a*, *b* and *c* are independent of the pressure and coincide with the lines *I*, *II* and *III + VII* from Fig. 9. The lines *d* and

¹⁾ Where the equilibrium $\text{CO}:\text{CO}_2$ with $\text{FeO} + \text{Fe}_3\text{O}_4$ (*b*) and of $\text{CO}:\text{CO}_2$ with $\text{Fe} + \text{FeO}$ (*c*) is independent of the pressure and of the presence of carbon, the projection of *II* will coincide with the line *b* in the section for constant pressure and those of *III* with *c*. These lines have been determined by BAUR and GLAESSNER.

i are, however, very independent of the pressure and shift at a larger pressure, the first towards the left, the second to above.

Lowering of the pressure therefore causes extension of the existable iron region inclosed by the lines c , i and d . Increased pressure causes this region to shrink.

Of the lines present in this figure d is known from the research of BOUDDOARD and others¹⁾, b and c have been determined by BAUR and GLAESSNER²⁾ between the temperatures 400° and 950° . The line b has according to these measurements a maximum of 46% CO at 500° and falls on increase of temperature to 23% CO at 950° . The line c has a minimum at 675° and 58% CO and rises afterwards to 940° and 75% CO. The point of intersection II is for 1. atmosphere at 647° and 37% CO, III at 685° and 59% CO.

As to the points VII and IX and the lines i and l no mention is made thereof by BAUR and GLAESSNER. Probably a part of the points determined by them will belong not to c , but to line l . As however they do not state any analysis of the solid phase, this cannot now be decided.

If the pressure is increased to above that of the quintuple point O , the lines III and VII (Fig. 8) are no longer cut but instead thereof VI . The existable region of Fe then disappears and the section becomes as shown in Fig. 11.

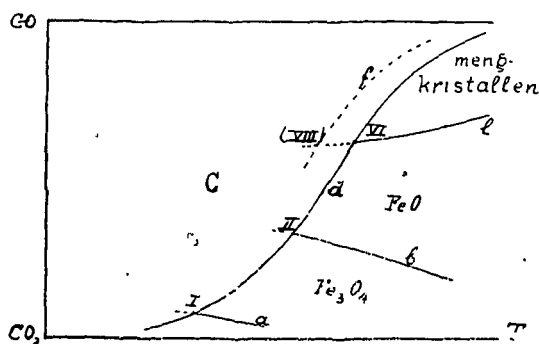

Fig. 11.

The lines c and i have disappeared in this section and with these the equilibria III , IX and VII . In the place thereof arrives the equilibrium VI . FeO now does not pass into iron on reduction in contact with carbon, but directly forms mixed crystals.

An investigation to decide the most important points in these equilibria is now in progress. The results will be communicated in due course.

Delft.

Laboratory inorg. and phys. chemistry
Technical University.

¹⁾ l. c. p. 1.

²⁾ Z. f. physik. Ch. 43, 354 (1903).

Chemistry. - "*Birefractive colloidal solutions*" by Prof. W. REINDERS. Communicated by Prof. J. BÖESEKEN.

(Communicated in the meeting of May 27, 1916).

H. FREUNDLICH, H. DIESELHORST and W. LEONHARDT describe in the "Festschrift für ELSTER and GEITEL"¹⁾ a remarkable phenomenon observed with vanadium oxide sol. The reddish-brown, very permanent colloidal solution, which is quite clear with transmitted light exhibits with incident light, on stirring, silky schliers²⁾ looking like a swarm of very minute crystals; at the same time it becomes birefractive. If the solution is allowed to flow through a tube with rectangular section placed between two crossed nicols, the field remains dark when the direction of the stream is parallel to the direction of extinction of one of the nicols; it however becomes strongly luminous so soon as the direction of the stream makes a certain angle therewith.

An elucidation of this phenomenon was given by the ultramicroscope which instead of luminous points showed very slender elongated needles, or pillars. When at rest these will occupy an arbitrary position so that the solution is then altogether isotropic. When the liquid is stirred, these needles will, however, arrange themselves with their axis in the direction of the movement. The particles are then directed and a column of liquid with all these particles similarly directed will be capable of behaving like an optic monaxial crystal whose optical axis coincides with the direction of the stream. A further investigation with convergent polarised light has completely confirmed this conception. It further appeared that, not only by mechanical stirring or by streaming, but also by introducing a magnetic field or by cataphoresis, the liquid becomes birefractive. H. R. KRUYT³⁾ has been able to confirm by ultramicroscopic investigation that cataphoresis is really associated with a directing of the particles.

Whereas to the form of the particles and their being directed by external forces no further doubt need exist, this is by no means the case with the nature of the particles themselves. Are these anisotropic already, are they minute crystals, or may we suppose them to be isotropic and explain the double refraction by the unequal elasticity in different directions of the solution as an homogeneous whole?

¹⁾ Arbeiten aus den Gebieten der Physik, Mathematik und Chemie, Braunschweig 1915, 453.

²⁾ Prof. G. A. F. MOLENGRAAFF informed me, that the word *schlier* as a translation of the German word *Schliere* has been used by R. A. DALY in his book "Igneous rocks and their origin" 1914 p. 448.

³⁾ These Proceedings Vol. XVIII. p. 1625.

A similar question arose in 1902 in regard to the *phenomenon of MAJORANA*¹⁾ based on the fact that a colloidal solution of $\text{Fe}(\text{OH})_3$ becomes birefractive in a magnetic field and exhibits dichroism.

COTTON and MOUTON²⁾, who have studied this phenomenon very accurately come, after full discussion of the different possibilities, to the conclusion that the explanation founded on the assumption of equally-directed, elongated but themselves isotropic particles is not satisfactory and that we must assume that the particles themselves are anisotropic. The idea that they consist already of small crystals seems to them a very likely one.

DIESSELHORST and FREUNDLICH do not express themselves positively on this question. At the discussion following a lecture of the last named at the meeting of the Bunsengesellschaft³⁾ the question aroused great interest, without, however, an agreement being arrived at.

For our conception as to the amorphous condition and as to the nature of colloidal solutions it is of much importance. It also bears on the question what dimension the particles must have in order to exhibit crystalline properties and whether there is a continuity between free molecules and crystals.

In this respect F. and D. already pointed to the great similarity which this vanadium oxide sol exhibits with the liquid crystals. According to the structural-chemical investigations of VORLÄNDER⁴⁾ the molecules of these anisotropic liquids must have an elongated form. Also LEHMANN⁵⁾ points to this and BOSE⁶⁾ explains the anisotropism of these liquids by assuming that the elongated molecules unite to clusters wherein they all have the same direction.

Finally, FREUNDLICH⁷⁾ favours most the idea that the elongated particles of the V_2O_5 sol might be similar clusters of equally-directed molecules which, however, may not yet be called crystals, a link between amorphous and crystalline. It appears to me that such an assumption causes an unnecessary complication and that it is simpler to look upon these needles as being already crystals.

In this case there must be a continuity between these ultra-microns and the macro- or microscopically visible crystals.

1) Rendiconti Acc. Lincei XI (1902)¹, 536; XI (1902)², 90.

2) Ann de chim. et de phys. (8) 11, 145, 289 (1907).

3) Zeitschr. f. Electrochem. 22 27 (1916).

4) Bes. d. Deutsch chem. Ges. 40, 1970 (1907).

5) Die neue Welt der flüssigen Krystalle 1911, 187.

6) Phys. Zeitschr. 9, 708.

7) Z. f. Elektrochem, 22, 32.

I have endeavoured in two ways to demonstrate this continuity.

1. by allowing V_2O_5 particles to grow until they should have attained microscopic dimensions.

2. by so modifying the conditions of formation of the crystals of substances, which in ordinary circumstances form distinctly observable crystals, that they can only attain ultramicroscopic dimensions and by observing whether in this manner birefractive sols are formed also.

I. *The growth of V_2O_5 particles.*

It is a well known phenomenon that colloidal or very finely divided crystalline precipitates gradually become crystalline or more coarsely crystalline when they are left in contact with the liquid in which they originated.

A similar growth of the particles is also observable with the V_2O_5 sol. The freshly prepared sol is but little turbid with incident light and does not, on shaking, exhibit the silky diffusions, or only so with exceedingly strong illumination. The old sol is visibly more turbid and exhibits the silky schliers. Ultramicroscopically, FREUNDLICH and DIESSELHORST found the first to be hardly or not at all resolvable in ultramicrones, in the second they noticed very plainly the elongated particles. In the effect of the double refraction they found, however, no difference. No special attention, however, is devoted to this point.

As the recrystallisation proceeds as a rule much more rapidly at a higher temperature than at a lower one, I have watched the change of the V_2O_5 sol on heating on a water-bath.

The sol was prepared by triturating 6 grams of NH_4VO_3 in a mortar with the equivalent quantity of 3 norm. HCl. After 10 minutes the liquid was filtered through a BUCHNER funnel. Washing was continued until the filtrate became darker and the filter got clogged. The deposit was then again washed twice by decantation and then brought into colloidal solution by briefly shaking with 150 cc. of water. The following day it was separated from a very gelatinous deposit and filtered. The clear dark brownish-red solution contained 12.4 grams of V_2O_5 per Litre.

A portion was preserved at the ordinary temperature (IIa) and another portion heated on the water-bath in a Jena flask closed with a funnel (temp. 90°) the traces of water evaporating thus being constantly replaced. After 1, $2\frac{1}{2}$, 5 and 9 hours a part of the liquid was pipetted off and rapidly cooled. These portions are called IIb, IIc, IId and IIe.

With transmitted light they were all equally clear and of the same colour.

With powerful incident light $II\alpha$ was somewhat turbid but, on shaking, without a silky lustre; the others were always turbid in a steadily increasing degree and always exhibited an increasing silky lustre.

Placed in a 5 mm. wide cuvette between crossed nicols through which passed Na-light $II\alpha$ gave on stirring with a glass rod a very faint luminosity. With IIb the luminosity was very bright and regular and quickly disappeared when stirring ceased. With IIc a strong flashing took place, not regular however; dark and luminous schliers passed through the field, which again disappeared slowly; $II\delta$ and IIe exhibited this phenomenon still much stronger. Even without stirring the entire field was filled with dark and luminous schliers, which on stirring changed places. It made the impression as if a part was gelatinised. Also macroscopically the schliers in the cuvette were very plainly visible and when emptying the cuvette gelatinous, little lumps were present which, however, on dilution with water disappeared and dissolved evenly. The viscosity of the heated sols, particularly of IIe , was plainly greater than that of the unheated sol. ¹⁾

On examining under the ultramicroscope ²⁾ with cardioid-condenser $II\alpha$ exhibited many small strongly luminous ultramicrosomes with little or no difference in longitudinal or latitudinal dimension.

IIb exhibited, beside these more circular and very luminous particles, very slender, faintly luminous long needles in the background.

With IIc these slender bluish-luminous needles are more predominant, the whole field is filled with them and the bright luminous round particles have mostly disappeared.

$II\delta$ also yielded many of these slender needles both very small and larger ones. Whereas, however, in the previous sols the particles

¹⁾ Two days after these experiments, the viscosity of these sols was determined with an OSTWALD viscosimeter. The results were (temp. 20°).

	Flow in seconds	Relative viscosity as compared with water
water	93,0	1,00
$II\alpha$	167,0	1,80
IIb	194,2	2,09
IIc	209,0	2,25
$II\delta$	248	2,64
IIe	663	7,13.

²⁾ ZEISS apochromatic V, compensation ocular 18.

freely moved about unrestrained, this was not the case here. Definite schliers of equally directed particles were very distinctly visible so that figures were formed which made one think of iron filings in a magnetic field or of hairs on a fur. A regularity in these figures is, however, wanting.

In IIc this formation of schliers was still more stronger pronounced. The equally directed particles moved about in the schliers as in little water streams between more tranquil parts. Occasionally in such a stream an obstacle was visible round about which the stream divided in two, then again to unite to one whole.

In a very convincing manner was thus brought here to light the inclination of the particles to arrange themselves all in the same direction in streaming water. The schliers macroscopically visible in polarised light will be no doubt formed in a similar manner by particles pointing in the same direction. In order to observe the influence of the dilution the quartz cuvette was cautiously opened and the sol present therein diluted with a drop of water when it was again examined under the microscope. The gelatinous mass had entirely disappeared; separate streams were no more to be seen and the whole field of vision was replete with the long needles in quite unrestrained motion such as was also the case with IIb and IIc.

The entire experiment thus shows

1. in the freshly prepared sol the ultramicrones do not exhibit a one-sided growth, the long needles are wanting.
2. on heating are formed needle-shaped ultramicrones of which the visible number and the size increases with the period of heating.
3. the phenomenon of double refraction is very trifling with the sol one day old, but gets stronger on heating.
4. The viscosity of the solution increases with the period of heating and finally there are formed quite transparent somewhat gelatinous lumps, which on dilution redissolve.

The sol used in this experiment was rather concentrated and even without heating it changed after some days to such an extent that on stirring it gave a decided double refraction. As it was not examined until one day after it had been prepared, the question whether entirely fresh sol was also birefractive remained unanswered.

Therefore, a new sol was prepared, the precipitate being obtained from a strong solution of NH_4VO_3 and hydrochloric acid. This precipitate was washed rapidly and brought into colloidal solution so that the sol was already filtered an hour after the precipitation and ready for investigation (Da). Per litre it contained 5.2 grams of V_2O_5 . It also was very clear with incident light and gave no silky lustre

on stirring. The ultramicroscopic image showed clear round particles on a faint opalescent, optically non-resolvable back ground. On running through a tube with rectangular section (interior 8×2 mm.) at an angle of 45° placed between two crossed nicols in a ray of Na-light, *absolutely no flashing* could be noticed; the field remained quite dark.

A part of the solution was now heated for 4 hours on the water-bath (Db). It then, on stirring, exhibited the silky lustre. Ultramicroscopically very delicate needles were visible. When running through the tube placed at an angle of 45° between crossed nicols, the field became very strongly luminous; on placing it parallel to the direction of the polarization of one of the nicols the field, during the streaming remained dark.

The freshly prepared sol is therefore not birefractive. The phenomenon only sets in and increases in strength with the formation and the growth of the ultramicroscopic needles.

The solution Db was again heated for 12 hours on the water-bath. The particles were increased in dimension but not microscopically visible.

In a five months old fairly concentrated sol large ultramicroscopic needles were visible, which, however, were out of reach with the ordinary microscope.

Summarising it appears in a very convincing manner that a slow growth of the V_2O_5 ultramicrosols is observable. This, however, is so trifling that we have hitherto not succeeded in obtaining particles of microscopically observable dimension.

II. *Birefractive sols of crystallisable substances.*

The peculiar silky lustre exhibited by old V_2O_5 sols on stirring is also noticed in the formation of different crystalline precipitates.

Some of these suspensions such as of $BaSO_4$, $BaSiF_6$, $SrSO_4$, mica, kaolin, soap, Hg_2Cl_2 and PbI_2 were now tested as to double refraction, of these the two last gave a positive result.

In order to succeed, the precipitate must, however, be very finely divided and not deposit so that the suspension has a colloidal character. It is obtained in that condition by allowing it to form in a very dilute solution and in the presence of a protective colloid.

PbI₂. a. 1 cc. of 0,1 n. Pb-acetate + 8 cc. of 0.05% gelatin + 1 cc. of 0,1 n. KI were added together. There is formed an orange yellow suspension of a beautiful silky precipitate. This was too turbid to

be investigated in a cuvette of 5 mm. in polarised light. It was therefore, diluted with an equal volume of water and now gave between two crossed nicols on stirring, very plainly an illumination of the field.

Microscopically were visible apparently round particles of about 1μ section in a strong Brownian movement. With some which were a little larger it was plainly visible in these rotations that they were flat. Evidently we are dealing here with the small hexagonal mother of pearl-like glittering plates, which on crystallisation from warm gelatin-free solutions can be easily obtained in a larger dimension.

b. Pb-acetate and KI were mixed in the same proportion and the same dilution with this difference, however, that the gelatin solution was now 0.3%. The solution was warmed a little, so that the originally yellow amorphous turbidity dissolved clear and colourless and the liquid was then cooled. After a quarter of an hour the solution was *greenish-yellow* opalescent with incident light, *brown* with transmitted light. After the lapse of 6 hours the turbidity had become somewhat stronger, but no deposit had formed yet; also none after 20 hours and on filtering the liquid passed unchanged through the filter. After 3 weeks a portion had subsided but the supernatant liquid had still the same appearance as the 6 hours old colloidal suspension.

At first the solution gave no silky lustre on stirring, but did so after half an hour. Between crossed nicols it gave on stirring a bright illumination of the field. When streaming through a tube with rectangular section, placed between the 2 crossed nicols the field became luminous when the direction of the stream made an angle of 45° with that of the direction of polarisation of the nicols. When it was parallel therewith the field remained dark.

Although the phenomenon was very much less strong than with V_2O_5 -sol, the PbI_2 -sol is still essentially of the same nature; the streaming column of liquid behaves like a birefractive crystal, of which the directions of extinction rest parallel and perpendicular to the direction of the stream.

Microscopically, nothing could be distinguished. The ultramicroscope exhibited very many small particles with a strong Brownian movement, yellow, brownish, red or of a more blue colour. Their light intensity varied very much, sometimes they suddenly dived in the field, and reappeared again. They made a strong impression of little discs toppling over their side.

As we now know that the PbI_2 crystals, on addition of increasing

quantities of gelatin, are obtained in steadily decreasing dimensions, we may assume that the ultramicrosomes in this gelatin-rich solution are again small PbI_2 crystals, hence, small plates of an optic monaxial crystal of which the optic axis stands perpendicular to the plane of this plate.

On streaming, these plates will arrange themselves parallel to the direction of the stream.

The optic axis then stands perpendicular to the direction of the stream. It is evident that a column of these particles so directed will behave optically active and will extinguish parallel to or perpendicular to the direction of the stream.

HgCl. Solutions of NaCl and somewhat acidified $HgNO_3$ mixed in such proportion that the final solution contained 0.001 gram-molecule of HgCl per Litre, gave a nice silky suspension of HgCl needles of which the dimensions were about 0.5 at 10μ . These crystals belong to the tetragonal system and, according to GROTH¹⁾ are extraordinarily strongly birefractive.

By addition of some gelatin their dimension could be lessened. With 0.3% gelatin and 0.01 norm. HNO_3 a solution was obtained of yellowish-brown colour with transmitted light and milky bluish-white with incident light. It could be filtered without undergoing change and gave between crossed nicols a strong illumination of the field when being stirred. On running through a tube with rectangular section the field became luminous when the direction of the stream made an angle of 45° with the direction of polarisation of the nicols, but not if it ran parallel to one of them. The streaming column of liquid thus again behaves like a birefractive crystal of which the directions of extinction coincide with and stand perpendicular to the direction of the stream.

With the ultramicroscope elongated particles showing a peculiar flashing of light were very plainly visible; they dived suddenly in the field and reappeared and altogether made the impression of small pillars tumbling over their top. The apparent dimension of these particles varied from $\frac{1}{4} \times \frac{1}{2}$ to $\frac{1}{4} \times 3 \mu$.

The appearance of these particles altogether resembles that of the small HgCl crystals which could be obtained in a still microscopically visible dimension (up to $0.25 \times 1\mu$) by addition of somewhat less gelatin and which in a similar way displayed their Brownian movement.

As with the HgCl the size of the particles can be varied at will

¹⁾ GROTH, Chemische Krystallographie, (1906) I, 214.

and reduced to ultramicroscopic dimension and as the appearance of these particles remains quite the same, we may certainly assume that the ultramicrosomes also are small crystals.

The double refraction of the Hg sol must, therefore, be attributed to the presence of ultramicroscopic tetragonal needles which, when the liquid is streaming, arrange themselves parallel to each other.

Summarizing we thus may say that there exists continuity between the crystalline suspensions of PbI_2 and HgCl_2 and the colloidal solutions of these substances which form in definite circumstances and become birefractive when in motion. The double refraction of these sols must be attributed to the crystalline structure of the ultra-microsomes.

In analogy herewith it is probable that also the ultramicrosomes of the V_2O_5 -sol must be regarded as micro-crystals:

Delft.

*Inorganic and physico-chemical
Laboratory Technical University.*

Physics. — “*The field of a single centre in EINSTEIN’S theory of gravitation, and the motion of a particle in that field.*”. By J. DROSTE. (Communicated by Prof. H. A. LORENTZ).

(Communicated in the meeting of May 27, 1916).

In two communications¹⁾ I explained a way for the calculation of the field of one as well as of two centres at rest, with a degree of approximation that is required to account for all observable phenomena of motion in these fields. For this I took as a starting-point the equations communicated by EINSTEIN in 1913²⁾. EINSTEIN has now succeeded in forming equations which are covariant for all possible transformations³⁾, and by which the motion of the perihelion of Mercury is entirely explained⁴⁾. The calculation of the field should henceforth be made from the new equations; we will make a beginning by calculating the field of a single centre at rest. We intend to calculate the field completely and not, as before, only the terms of the first and second order. After this, we investigate the

¹⁾ Volume XVII p. 998 and vol. XVIII p. 760.

²⁾ “Entwurf einer verallgemeinerten Relativitätstheorie und einer Theorie der Gravitation”, TEUBNER. Or: Zeitschrift für Mathematik und Physik, vol. 62.

³⁾ “Die Feldgleichungen der Gravitation” Sitzungsberichte der Kon. Preuss. Akad. der Wiss. 1915, p. 844.

⁴⁾ “Erklärung der Perihelbewegung des Merkur aus der allgemeinen Relativitätstheorie” Sitzungsberichte der Kon. Preuss. Akad. der Wiss. 1915, p. 831.

motion of a body, so small that it does not produce any observable change in the original field.

1 The equations for the calculation of the field can be got from a principle of variation. Where matter is absent ($T_{ij} = 0$) the variation of the integral

$$\iiint G \sqrt{-g} dx_1 dx_2 dx_3 dx_4$$

must be zero, if the variations of all g 's and their first derivatives be zero at the threedimensional limits of the fourdimensional region over which the integral is extended. Here G represents the quantity

$$G = 2 \sum_{ij} g^{ij} \left(\frac{\partial}{\partial x_i} \left\{ \begin{matrix} ij \\ j \end{matrix} \right\} - \frac{\partial}{\partial x_j} \left\{ \begin{matrix} ij \\ i \end{matrix} \right\} \right) + 2 \sum_{ijk} \left(\left\{ \begin{matrix} ij \\ k \end{matrix} \right\} \left\{ \begin{matrix} kj \\ j \end{matrix} \right\} - \left\{ \begin{matrix} ii \\ k \end{matrix} \right\} \left\{ \begin{matrix} kj \\ j \end{matrix} \right\} \right) g^{ij}, \quad (1)$$

$$\left\{ \begin{matrix} ij \\ k \end{matrix} \right\} = \sum_l g^{kl} \left[\begin{matrix} ij \\ l \end{matrix} \right], \quad \left[\begin{matrix} ij \\ l \end{matrix} \right] = \frac{1}{2} \left(\frac{\partial g_{il}}{\partial x_j} + \frac{\partial g_{jl}}{\partial x_i} - \frac{\partial g_{ij}}{\partial x_l} \right).$$

For a centre at rest and symmetrical in all directions it is easily seen that

$$ds^2 = w^2 dt^2 - u^2 dr^2 - v^2 (d\vartheta^2 + \sin^2 \vartheta d\varphi^2), \quad (2)$$

w, u, v only depending on r , and (ϑ, φ) representing polar coordinates. Now, if g_{ij} and therefore also g^{ij} are all zero, if $i \neq j$, G breaks up into six pieces, each of them relating to two indices. We collect the terms belonging to α and β and name their sum $G_{\alpha\beta}$.

Now, if a, b, c represent three different indices,

$$\left[\begin{matrix} ab \\ c \end{matrix} \right] = 0, \quad \left[\begin{matrix} aa \\ c \end{matrix} \right] = -\frac{1}{2} \frac{\partial g_{aa}}{\partial x_c}, \quad \left[\begin{matrix} ab \\ a \end{matrix} \right] = \frac{1}{2} \frac{\partial g_{aa}}{\partial x_b}, \quad \left[\begin{matrix} aa \\ a \end{matrix} \right] = \frac{1}{2} \frac{\partial g_{aa}}{\partial x_a}.$$

So

$$\left\{ \begin{matrix} ab \\ c \end{matrix} \right\} = 0, \quad \left\{ \begin{matrix} aa \\ c \end{matrix} \right\} = -\frac{1}{2} g^{cc} \frac{\partial g_{aa}}{\partial x_c}, \quad \left\{ \begin{matrix} ab \\ a \end{matrix} \right\} = \frac{1}{2} g^{aa} \frac{\partial g_{aa}}{\partial x_b}, \quad \left\{ \begin{matrix} aa \\ a \end{matrix} \right\} = \frac{1}{2} g^{aa} \frac{\partial g_{aa}}{\partial x_a}.$$

Let the first sum in (1) contribute to $G_{\alpha\beta}$ the terms, in which $i = \alpha, j = \beta$, or $i = \beta, j = \alpha$. By taking for α and β successively the six couples of indices and adding the expressions, we get exactly the first sum of (1).

Let the second sum in (1) contribute to $G_{\alpha\beta}$ those terms in which one of the *differentiated* g 's contains the index α , the other β . So that sum too will have been broken up into six pieces, one of which relates to α and β .

In that way we obtain

$$G_{\alpha\beta} = g^{\alpha\alpha} \frac{\partial}{\partial x_\nu} \left(g^{\beta\beta} \frac{\partial g_{\beta\beta}}{\partial x_\nu} \right) + g^{\alpha\alpha} \frac{\partial}{\partial x_\beta} \left(g^{\beta\beta} \frac{\partial g_{\alpha\alpha}}{\partial x_\beta} \right) + g^{\beta\beta} \frac{\partial}{\partial x_\beta} \left(g^{\alpha\alpha} \frac{\partial g_{\alpha\alpha}}{\partial x_\beta} \right) + g^{\beta\beta} \frac{\partial}{\partial x_\alpha} \left(g^{\alpha\alpha} \frac{\partial g_{\beta\beta}}{\partial x_\alpha} \right) + g^{\alpha\alpha} g^{\beta\beta} \sum_{\alpha \neq i \neq \beta} g^{ii} \frac{\partial g_{\alpha\alpha}}{\partial x_i} \frac{\partial g_{\beta\beta}}{\partial x_i} \dots \dots \dots (3)$$

The equations of the field being covariant for all transformations of the coordinates whatever, we are at liberty to choose instead of r a new variable which will be such a function of r , that in ds^2 the coefficient of the square of its differential becomes unity. That new variable we name r again and we put

$$ds^2 = w^2 dt^2 - dr^2 - v^2 (d\vartheta^2 + \sin^2 \vartheta d\varphi^2) \dots \dots (4)$$

w and v only depending on r . We now find

$$G_{tt} = -\frac{4w''}{w}, G_{\vartheta\vartheta} = G_{\varphi\varphi} = -\frac{4v''}{v}, G_{t\vartheta} = G_{t\varphi} = -\frac{4v'w'}{vw}, G_{\vartheta\varphi} = \frac{4}{v^2} - \frac{4v'^2}{v^3}.$$

In these equations accents represent differentiations with respect to r . So

$$G = \frac{4}{v^2} - \frac{4v'^2}{v^3} - \frac{8v'w'}{vw} - \frac{8v''}{v} - \frac{4w''}{w}.$$

Now, as $\sqrt{-g} = v^2 w \sin \vartheta$, the function to be integrated in the principle of variation becomes

$$4(w - wv'^2 - 2vv'w' - 2vww'' - v^2w'') \sin \vartheta.$$

We now apply the principle to the region $t_1 \leq t \leq t_2, r_1 \leq r \leq r_2$. By effecting the integrations with respect to t, ϑ and φ we find the condition

$$\oint_{r_1}^{r_2} (w - wv'^2 - 2vv'w' - 2vww'' - v^2w'') dr = 0.$$

This gives us

$$2vv'' + v'^3 = 1 \dots \dots (5)$$

and

$$vw'' + v'w' + wv'' = 0 \dots \dots (6')$$

These are the equations of the field required.

2. To solve (6), we introduce instead of r the quantity $x = v$ as an independent variable by which, on taking account of (5), (6) changes into

$$(1 - x^2) \frac{d^2w}{dx^2} - 2x \frac{dw}{dx} + 2w = 0.$$

This equation is satisfied by $w = x$. The other particular solution is now also easily found, viz.

$$w = 1 - \frac{1}{2} x \log \frac{1-x}{1+x}.$$

But we want w to be a finite constant if $v' = 1$ (for $r = \infty$). Then w must be equal to x , if we take the constant to be 1 (the speed of light then approaches to 1 at large distances from the centre).

The introduction of x in (5) gives

$$\frac{dv}{dx} = \frac{2\alpha x}{1-x^2},$$

from which we immediately find

$$v = \frac{\alpha}{1-x^2},$$

α being a constant of integration.

Differentiating this relation with respect to r , we get

$$v' = \frac{2\alpha x}{(1-x^2)^2} \frac{dx}{dr}$$

or, v' being equal to x ,

$$dr = \frac{2\alpha dx}{(1-x^2)^2}.$$

So (4) changes into

$$ds^2 = x^2 dt^2 - \frac{4\alpha^2}{(1-x^2)^4} dx^2 - \frac{\alpha^2}{(1-x^2)^2} (d\vartheta^2 + \sin^2 \vartheta d\rho^2).$$

So we have now been led again to introduce another variable instead of r , viz. x . The form obtained leads us to introducing the variable $\xi = 1 - x^2$. Then

$$ds^2 = (1-\xi) dt^2 - \frac{4\alpha^2}{(1-\xi)\xi^4} d\xi^2 - \frac{\alpha^2}{\xi^2} (d\vartheta^2 + \sin^2 \vartheta d\rho^2).$$

Lastly we put -

$$\xi = \frac{\alpha}{r}$$

This r is not the same as occurs in (4). We obtain

$$ds^2 = \left(1 - \frac{\alpha}{r}\right) dt^2 - \frac{dr^2}{1 - \frac{\alpha}{r}} - r^2 (d\vartheta^2 + \sin^2 \vartheta d\rho^2) \quad (7)$$

We have chosen the coordinates in a particular manner; it is now of course also very easy to introduce for r another variable, which is a function of r .¹⁾

3. From (7) we can immediately deduce some conclusions. The point (r, ϑ, ρ) lies at a distance

$$\sigma = \int \frac{dr}{\sqrt{1 - \frac{\alpha}{r}}} = r \sqrt{1 - \frac{\alpha}{r}} + \alpha \log \left(\sqrt{\frac{r}{\alpha} - 1} + \sqrt{\frac{r}{\alpha}} \right). \quad (8)$$

¹⁾ After the communication to the Academy of my calculations, I discovered that also K. SCHWARZSCHILD has calculated the field. Vid : Sitzungsberichte der Kön. Preuss. Akad. der Wiss. 1916, page 189. Equation (7) agrees with (14) there, if R is read instead of r .

from the point, where the radius intersects sphere $r = a$, if $r > a$ and supposing that (7) remains valid up to $r = a$. In future we will always make these two suppositions, as we shall see, that a moving particle outside sphere $r = a$ can never pass that sphere, we may, in studying its motion, disregard the space $r < a$. Should (7) cease to be valid as soon as r becomes $< R$, we need only exclude the space $r < R$ from the conclusions which will still be made, to make them valid again.

If r be very large with respect to a , the proportion $\delta : r$ approaches to 1.

The circumference of a circle $r = \text{const.}$ is $2\pi r$ by (7); this shows how r can be measured. Circle a has the circumference $2\pi a$.

One might in (7) perform a substitution $t = f(r, \tau)$. Then a term containing $dr d\tau$ would arise and the velocity c of light, travelling along r , would have to be calculated from an equation of the form

$$F_1(r, \tau) + F_2(r, \tau) c - F_3(r, t) c^2 = 0$$

and would have *two* values, one for light coming from the centre, the other for light moving towards it. Moreover these values would depend on t . In consequence of the last fact we should not name the field stationary and the first fact does not agree with the way in which time is compared in two different places. So, if we want to retain both advantages, such a substitution is not allowed, though it may, of course, always be done, if we are willing to give up these advantages.

We will point out that, as (7) is known now, G can be found as a function of r . The result is $G = 0$, as it must always be found where matter is absent.

4. We now proceed to the calculation of the equations of motion of a particle in the field.

The equations of motion express the fact that the first variation of the integral

$$\int_{t_1}^{t_2} L dt$$

will be zero, if the varied positions for $t = t_1$ and $t = t_2$ are the same as the actual ones. L represents the quantity

$$L = \frac{ds}{dt} = \sqrt{1 - \frac{\alpha}{r} - \frac{\dot{r}^2}{1 - \frac{\alpha}{r}} - r^2 \vartheta^2 - r^2 \sin^2 \vartheta \varphi^2}, \dots \quad (9)$$

where $r = \frac{dr}{dt}$, $\dot{\vartheta} = \frac{d\vartheta}{dt}$, $\dot{\varphi} = \frac{d\varphi}{dt}$.

One of the equations of motion is

$$\frac{d}{dt} \left(\frac{\partial L}{\partial \dot{\varphi}} \right) = 0$$

or

$$\frac{r^2 \sin^2 \vartheta \dot{\varphi}}{L} = \text{const.},$$

which proves that φ , once being zero, keeps that value.

Now, as we can always choose ϑ and φ in such a way that φ becomes zero for a certain value of t and as φ will then always remain zero, the motion takes place in a plane.

We choose the coordinates in such a manner, that this plane becomes the plane $\vartheta = \frac{\pi}{2}$. Then (9) passes into

$$L = \sqrt{1 - \frac{\alpha}{r} - \frac{r^2}{1 - \frac{\alpha}{r}} - r^2 \dot{\varphi}^2} \dots \dots \dots (10)$$

The equations of motion are

$$\frac{d}{dt} \left(\frac{\partial L}{\partial \dot{\varphi}} \right) = 0, \quad \frac{d}{dt} \left(\frac{\partial L}{\partial \dot{r}} \right) - \frac{\partial L}{\partial r} = 0 \dots \dots \dots (11)$$

From these two it follows that

$$\frac{d}{dt} \left(L - r \frac{\partial L}{\partial r} - \varphi \frac{\partial L}{\partial \dot{\varphi}} \right) = 0$$

or

$$\frac{d}{dt} \left(\frac{1 - \frac{\alpha}{r}}{L} \right) = 0 \dots \dots \dots (12)$$

Instead of the two equations (11) we may consider the system, consisting of (11) and (12). The two systems are equivalent only in case $r \neq 0$; so for the circular motion we shall have to return to the second equation (10).

We now obtain

$$\frac{1 - \frac{\alpha}{r}}{L} = \text{const.}, \quad \frac{r^2 \dot{\varphi}}{L} = \text{const.},$$

and so

$$\frac{r^2 \dot{\varphi}}{1 - \frac{\alpha}{r}} = \text{const.}$$

This yields the equations

$$\frac{1}{1 - \frac{\alpha}{r}} - \frac{\dot{r}^2}{\left(1 - \frac{\alpha}{r}\right)^3} - \frac{r^2 \dot{\varphi}^2}{\left(1 - \frac{\alpha}{r}\right)^2} = A \dots \dots \dots (13)$$

and

$$\frac{r^2 \dot{\varphi}}{1 - \frac{\alpha}{r}} = B \dots \dots \dots (14)$$

We will now just express the quantities $\ddot{\varphi}$ and \ddot{r} in $\dot{\varphi}$, r and \dot{r} ; this is easily done by differentiating (13) and (14) with respect to t . The result is

$$\ddot{\varphi} = \frac{\dot{\varphi} \dot{r}}{1 - \frac{\alpha}{r}} \cdot \frac{\alpha}{r^2} - \frac{2\dot{\varphi} \dot{r}}{r} \dots \dots \dots (15)$$

and

$$\ddot{r} = -\frac{\alpha}{2r^2} \cdot \left(1 - \frac{\alpha}{r}\right) + \frac{3}{2} \cdot \frac{\alpha}{r^2} \frac{\dot{r}^2}{1 - \frac{\alpha}{r}} + r\dot{\varphi}^2 \left(1 - \frac{\alpha}{r}\right) \dots (16)$$

5. From (15) and (16) it follows if $r = \dot{\varphi} = 0$

$$\ddot{\varphi} = 0, \quad \ddot{r} = -\frac{\alpha}{2r^2} \left(1 - \frac{\alpha}{r}\right)$$

This is the acceleration in case of a particle at rest. It is directed towards the centre.

\ddot{r} has its greatest value (at rest) at the distance $r = \frac{3}{2} \alpha$ from the centre; the greatest value of $\ddot{\sigma}$ is attained for $r = \frac{5}{4} \alpha$.

6. *The motion may be circular.* As \dot{r} is then continually zero, we return to the equations (11). The second shows

$$\frac{\partial L}{\partial r} = 0,$$

i. e.

$$\dot{\varphi}^2 = \frac{\alpha}{2r^3} \dots \dots \dots (17)$$

Substituting this in (10) and putting $\dot{r} = 0$ we find

$$L^2 = 1 - \frac{3\alpha}{2r},$$

so that r must be $> \frac{3}{2} \alpha$, if L^2 or, what comes to the same thing, ds^2 shall be positive.

Formula (17) is the same as in NEWTON'S theory.

7. We will now consider the case of $\dot{\varphi}$ being continually zero, i.e. that the particle always moves on the same radius. From (13) we easily conclude (we shall afterwards show this in general i.e. if $\dot{\varphi}$ be not identical zero) that the particle never reaches sphere $r = \alpha$.

If we call

$$\dot{\sigma} = \frac{\dot{r}}{\left(1 - \frac{\alpha}{r}\right)^{\frac{1}{2}}}, \quad \ddot{\sigma} = \frac{d\dot{\sigma}}{dt}$$

for abbreviation velocity and acceleration, then (13) gives us for the velocity the formula

$$\dot{\sigma}^2 = \left(1 - \frac{\alpha}{r}\right) \left(1 - A + A \frac{\alpha}{r}\right) \dots \dots \dots (18)$$

and (16) for the acceleration

$$\ddot{\sigma} = -\frac{\alpha}{2r^2} \left[\sqrt{1 - \frac{\alpha}{r}} - \frac{2\dot{\sigma}^2}{\sqrt{1 - \frac{\alpha}{r}}} \right] \dots \dots (19)$$

If we substitute (18) in (19) we obtain

$$\ddot{\sigma} = \frac{\alpha}{2r^2} \left(1 - 2A + 2A \frac{\alpha}{r}\right) \sqrt{1 - \frac{\alpha}{r}} \dots \dots (20)$$

From (19) follows, that the algebraic value of the acceleration only depends on the position and the velocity of the particle and does not change if we reverse the direction of the velocity. The constant A is never negative (as $L > 0$). If A lies between 0 and 1 ($A = 1$ included), then every value of r is possible according to (15). We then have a particle moving towards infinity or coming from it. For this motion the acceleration will, according to (20), once become zero, if $2A - 1 > 0$, i.e. $A > \frac{1}{2}$, viz. for

$$r = \frac{2A\alpha}{2A - 1};$$

for greater values of r the acceleration is directed towards the centre (attraction), for smaller values of r from the centre (repulsion). The acceleration is then zero in these positions viz. $r = \alpha$, $r = 2A\alpha/(A-1)$, $r = \infty$. In the first interval there will be repulsion, in the second attraction, within either interval there is an extreme. If $A > 1$ then, according to (18), r cannot be greater than $A\alpha/(A-1)$. Then

the motion is that of a particle first going away from the centre and then returning when $r = A\alpha/(A-1)$. The value $2A\alpha/(2A-1)$, of r , for which the acceleration becomes zero, is smaller than $A\alpha/(A-1)$. The particle ascends (during which there is first repulsion); at a given moment the acceleration becomes zero for $r = 2A\alpha/(2A-1)$, then we get attraction, which for $r = A\alpha/(A-1)$ has exhausted the motion and makes it return; the acceleration of the reversed motion is first positive, then becomes negative for $r = 2A\alpha/(2A-1)$ and the motion stops (infinitely slowly) for $r = \alpha$. In case that A lies between 0 and $\frac{1}{2}$, so that r can have all values, there is no point where the acceleration becomes zero. According to (20) there is then always repulsion; the velocity is maximum at an infinite distance viz, according to (18), $\sqrt{1-A}$ which lies between $\frac{1}{2}\sqrt{2}$ and 1.

8. We now return to the general case, where neither \dot{r} nor $\dot{\varphi}$ are continually zero. We must then take equations (13) and (14) as a starting point, by eliminating dt we find

$$\frac{1}{1-\frac{\alpha}{r}} - \frac{B^2}{r^4} \cdot \frac{1}{1-\frac{\alpha}{r}} \left(\frac{dr}{d\varphi}\right)^2 - \frac{B^2}{r^2} = A. \dots (21)$$

Expressing $d\varphi$ in r and dr we obtain

$$d\varphi = \frac{Bdr}{r^2 \sqrt{1 - \left(A + \frac{B^2}{r^2}\right)\left(1 - \frac{\alpha}{r}\right)}}$$

Putting now $\frac{\alpha}{r} = x$, we get

$$d\varphi = \frac{-dx}{\sqrt{x^3 - x^2 + \frac{A\alpha^2}{B^2}x + \frac{(1-A)\alpha^2}{B^2}}}$$

So φ becomes an elliptic integral in the variable x , and r therefore an elliptic function of φ . Of

$$x^3 - x^2 + \frac{A\alpha^2}{B^2}x + \frac{(1-A)\alpha^2}{B^2} = 0$$

let x_1, x_2, x_3 be the roots, so that

$$x_1 + x_2 + x_3 = 1, \quad x_1x_2 + x_2x_3 + x_3x_1 = \frac{A\alpha^2}{B^2}, \quad x_1x_2x_3 = \frac{(A-1)\alpha^2}{B^2} \dots (22)$$

then we can introduce as constants of integration the quantities x_1, x_2, x_3 (connected by the relation $x_1 + x_2 + x_3 = 1$) instead of A and B .

If we now introduce a new variable

$$z = x - \frac{1}{3}$$

putting

$$\begin{aligned} e_1 &= x_1 - \frac{1}{3}, \\ e_2 &= x_2 - \frac{1}{3}, \\ e_3 &= x_3 - \frac{1}{3}, \end{aligned}$$

we obtain

$$d\varphi = \frac{-\alpha z}{\sqrt{(z-e_1)(z-e_2)(z-e_3)}} \dots \dots \dots (23)$$

and we have

$$e_1 + e_2 + e_3 = 0 \dots \dots \dots (24)$$

Now, introducing the \mathcal{P} -function with the roots e_1, e_2, e_3 , we get

$$z = \mathcal{P}\left(\frac{1}{2}\varphi + C\right),$$

where C is a constant of integration, which may be complex; the real part is without signification as it only determines the direction in which φ will be zero. We take

$$z = \mathcal{P}\left(\frac{1}{2}\varphi + is\right), \dots \dots \dots (25)$$

and then find

$$\frac{\alpha}{r} = \frac{1}{3} + \mathcal{P}\left(\frac{1}{2}\varphi + is\right) \dots \dots \dots (26)$$

From (14) now follows

$$Bdt = \frac{r^2 d\varphi}{1 - \frac{\alpha}{r}} = \frac{\alpha^2 d\varphi}{x^2(1-x)} = -\alpha^2 \frac{dx}{x^2(1-x)\sqrt{(x-x_1)(x-x_2)(x-x_3)}}$$

or

$$\frac{B}{\alpha^2} dt = \frac{-dz}{\left(z + \frac{1}{3}\right)^2 \left(\frac{2}{3} - z\right) \sqrt{(z-e_1)(z-e_2)(z-e_3)}} \dots \dots \dots (27)$$

The problem under consideration gives rise to four constants of integration; two of which are e_1 and e_2 , the two others s (which can have only particular values) and a constant which arises after integration of (27) and is of no consequence as it only determines the moment at which $t = 0$.

From (27) it now follows immediately that the particle can never reach sphere $r = a$. For, if r became a , then z became $\frac{2}{3}$; (27) shows that this would require an infinitely long time. Sphere $r = a$, therefore, is never reached.

It also follows from (27) that an infinitely long time is required for z to reach $-\frac{1}{3}$. This is not at all strange, $z = -\frac{1}{3}$ corresponding to $r = \infty$. It may occur (if two e 's coincide) that there is still another value of r which cannot be attained, but is gradually approached; we will treat this case where it occurs.

9. Let us now first consider the case $e_1 = e_2 = e_3 = 0$.
Equation (23) becomes

$$d\varphi = \frac{-az}{z^{3/2}} \dots \dots \dots (28)$$

so

$$\varphi = \frac{2}{\sqrt{z}} = \frac{2}{\sqrt{\frac{\alpha}{r} - \frac{1}{3}}} \dots \dots \dots (29)$$

The value 3α of r , corresponding to $z = 0$, is, as is seen from (27), a value which is not attained. (29) shows that the motion takes place in a spiral which, extending to circle $r = \alpha$, making there with the radius a finite angle, and, turning an infinite number of times, approaches to circle $r = 3\alpha$ on the inside. The particle can never get out of sphere $r = 3\alpha$ and a motion such that the particle were from the beginning outside sphere $r = \alpha$ (and such that $e_1 = e_2 = e_3 = 0$), is impossible according to (28), as $\left(\frac{dz}{d\varphi}\right)^2$ should then be negative.

When r approaches to 3α then φ approaches to $\frac{1}{3\alpha\sqrt{6}}$ and consequently the velocity to $\frac{1}{\sqrt{6}}$.

10. We now come to the case of two e 's being equal and different from the third. Calling (the three e 's being real) the greatest e_1 , the smallest e_3 , we have two cases, viz.

$$e_2 = e_3 = -\frac{1}{2}e_1, e_1 = e_2 = -\frac{1}{2}e_3.$$

We first turn to the case $e_2 = e_3 = -\frac{1}{2}e_1$.

Excluding as before the interior of sphere $r = \alpha$, r must be $> \alpha$, so $z < \frac{2}{3}$. We put $e_2 = e_3 = -\alpha^2, e_1 = 2\alpha^2$; α be positive. Then (23) passes into

$$d\varphi = \frac{-dz}{(z + \alpha^2)\sqrt{z - 2\alpha^2}}$$

It is seen that z must be greater than $2\alpha^2$, and, as z must be smaller than $\frac{2}{3}$, we must have

$$2\alpha^2 < \frac{2}{3} \dots \dots \dots (30)$$

If $2\alpha^2 = \frac{2}{3}$, the particle is at rest on sphere $r = \alpha$.

Now putting $z = 2\alpha^2 + y^2$ we get

$$\frac{1}{2}d\varphi = \frac{-dy}{y^2 + 3\alpha^2}$$

and so

$$y = -a\sqrt{3} \operatorname{tg} \left(\frac{1}{2} a \varphi \sqrt{3} \right).$$

This gives us

$$r = \frac{a}{\frac{1}{3} + 2a^2 + 3a^2 \operatorname{tg}^2 \left(\frac{1}{2} a \varphi \sqrt{3} \right)} \dots \dots \dots (31)$$

The case $a = 0$ has been discussed in 9, we therefore put $a \neq 0$. When $\varphi = 0$, $r = a \cdot \left(\frac{1}{3} + 2a^2 \right)$, i.e. a value between $r = a$ and $r = 3a$. When φ approaches to $\pi / \sqrt{3}$ (a value which, from (30), exceeds π) r should approach to zero, according to (31). But first r must become equal to a , viz. when φ becomes

$$\varphi = \varphi_0 = \frac{2}{a\sqrt{3}} \cdot \operatorname{arc} \operatorname{tg} \frac{\sqrt{2-6a^2}}{3a}$$

and for this, according to (27), an infinite time is required as then $z = \frac{2}{3}$. So the motion is as follows. φ changes from $-\varphi_0$ to φ_0 , corresponding to $r = a$. The greatest value of r is reached at the moment when $\varphi = 0$, viz.

$$r = \frac{a}{\frac{1}{3} + 2a^2} < 3a;$$

when $\varphi = -\varphi_0$ (as well as when $\varphi = \varphi_0$) r becomes a . If r approaches to zero, φ_0 increases indefinitely and the motion approaches more and more to that which has been discussed in 9.

11. The case $e_1 = e_2 = -\frac{1}{2} e_3$.

Put $e_1 = e_2 = a^2$, $e_3 = -2a^2$, then (23) passes into

$$d\varphi = - \frac{dz}{(z-a^2)\sqrt{z+2a^2}} \dots \dots \dots (32)$$

As $z > -2a^2$, we may put $z = -2a^2 + y^2$. Then we get

$$d\varphi = - \frac{2 dy}{y^2 - 3a^2}.$$

Now, if $z > a^2$, and therefore $y^2 > 3a^2$, we get

$$y = a\sqrt{3} \operatorname{cotgh} \left(\frac{1}{2} a \varphi \sqrt{3} \right)$$

and

$$r = \frac{a}{\frac{1}{3} - 2a^2 + 3a^2 \operatorname{cotgh}^2 \left(\frac{1}{2} a \varphi \sqrt{3} \right)} \dots \dots \dots (33)$$

If, on the contrary, $z < a^2$ and consequently $y^2 < 3a^2$,

$$y = a\sqrt{3} \operatorname{tgh} \left(\frac{1}{2} a \varphi \sqrt{3} \right),$$

and so

$$r = \frac{a}{\frac{1}{3} - 2a^2 + 3a^2 \operatorname{tgh}^2 \left(\frac{1}{2} a \varphi \sqrt{3} \right)} \dots \dots \dots (33a)$$

z cannot pass a^2 and must moreover lie between $-\frac{1}{3}$ and $\frac{2}{3}$.

So we have the following cases:

A. $a^2 \geq \frac{2}{3}$. z lies between $-\frac{1}{3}$ and $\frac{2}{3}$; formula (33a) holds, r varies between ∞ and a , the first value is attained for

$$\varphi = \varphi_1 = \frac{1}{a\sqrt{\frac{2}{3}}} \log \frac{a\sqrt{\frac{2}{3}} + \sqrt{2a^2 - \frac{2}{3}}}{a\sqrt{\frac{2}{3}} - \sqrt{2a^2 - \frac{2}{3}}}$$

and the second for

$$\varphi = \varphi_2 = \frac{1}{a\sqrt{\frac{2}{3}}} \log \frac{a\sqrt{\frac{2}{3}} + \sqrt{2a^2 + \frac{2}{3}}}{a\sqrt{\frac{2}{3}} + \sqrt{2a^2 + \frac{2}{3}}}$$

An infinitely long time is required to reach either position

B. $a^2 < \frac{2}{3}$; z between a and $\frac{2}{3}$ Formula (33) must be applied, r varies between $a(\frac{1}{3} + a^2)$ and a , φ then changes from ∞ to

$$\varphi_3 = \frac{1}{a\sqrt{\frac{2}{3}}} \log \frac{\sqrt{2a^2 + \frac{2}{3}} + a\sqrt{\frac{2}{3}}}{\sqrt{2a^2 + \frac{2}{3}} - a\sqrt{\frac{2}{3}}}$$

The orbit comes from $r = a$ and approaches in a spiral to circle $r = a(\frac{1}{3} + a^2)$.

C. $\frac{1}{6} \leq a^2 < \frac{2}{3}$; z between $-\frac{1}{3}$ and a^2 . Formula (33a) now holds, r varies between ∞ and $a(\frac{1}{3} + a^2)$; φ changes from ∞ to ∞ . The orbit comes from infinity and turns in a spiral round the circle $r = a(\frac{1}{3} + a^2)$, which lies between circle $2a$ and circle a .

D. $a^2 < \frac{1}{6}$, z between $-2a^2$ and a^2 Formula (33a) must be applied, r varies between $a(\frac{1}{3} - 2a^2)$ and $a(\frac{1}{3} + a^2)$; φ changes from 0 to ∞ . The orbit is a spiral, coming from circle $a(\frac{1}{3} - 2a^2)$, which may have any radius $> 3a$, and approaching in a infinite number of turnings to circle $a(\frac{1}{3} + a^2)$, which lies between circle $2a$ and circle $3a$.

12. Now we will suppose the roots e_1, e_2, e_3 to be all different. As regards these roots, we may then distinguish two main cases, viz. the case of three real roots and the case of one real and two conjugate complex roots. In the first case we put $e_1 > e_2 > e_3$, in the second e_2 be the real root and the imaginary part of e_1 be positive. In either case we put, as usual, $e_1 = \mathcal{P}\omega_1$, $e_2 = \mathcal{P}\omega_2$, $e_3 = \mathcal{P}\omega$, with $\omega_2 = \omega_1 + \omega_3$ (not $-\omega_1 - \omega_3$).

The three roots are real. The only values possible for i s in equation (25) now are 0 and ω_3 (or congruent values). In the first case z varies from ∞ to e_1 and from e_1 to ∞ , while φ changes from 0 to $2\omega_1$ and from $2\omega_1$ to $4\omega_1$. One must, however, remember that, according to (27), z may not exceed the values $-\frac{1}{3}$ and $\frac{2}{3}$ (i. e. $r = \infty$ and $r = a$), but must remain between them. So if $e_1 > \frac{2}{3}$, it is impossible for i s to be zero. If $e_1 < \frac{2}{3}$, z varies between e_1 and $\frac{2}{3}$ and so r between $a/(\frac{1}{3} + e_1)$ and a . This case corresponds to 10 and

11B into which it passes when $e_2 = e_3 = -\frac{1}{2}e_1$ and when $e_2 = -2e_1$.

In the other case ($is \equiv \omega_3$) z varies from e_3 to e_2 and from e_2 to e_1 , while φ changes from 0 to $2\omega_1$ and from $2\omega_1$ to $4\omega_1$. There are various cases:

A. $e_2 \geq \frac{2}{3}$. z varies between $-\frac{1}{3}$ and $\frac{2}{3}$, φ between φ_1 and φ_2 for which

$$-\frac{1}{3} = \mathcal{P}\left(\frac{1}{2}\varphi_1 + \omega_3\right) \text{ and } \frac{2}{3} = \mathcal{P}\left(\frac{1}{2}\varphi_2 + \omega_3\right);$$

φ_1 lies between 0 and ω_1 , φ_2 between 0 and $2\omega_1$ ($\varphi_2 > \varphi_1$). r changes between ∞ and α . This case corresponds to 11A and passes into it for $e_2 = e_1 = -\frac{1}{3}$.

B. $e_2 \leq -\frac{1}{3}$, $e_2 < \frac{2}{3}$. z varies between $-\frac{1}{3}$ and e_2 , φ between φ_1 and $2\omega_1$; r changes from ∞ to $\alpha/(\frac{1}{3} + e_2)$, a value between 2α and α . This corresponds to 11C, in which it passes for $e_1 = e_2$, ω_1 then becoming infinite.

C. $e_2 > -\frac{1}{3}$, $e_2 < \frac{1}{3}$. z varies between e_3 and e_2 , φ between $-\infty$ and $+\infty$; r changes from $\alpha/(\frac{1}{3} + e_3)$, which may have all values $> 3\alpha$, to $\alpha/(\frac{1}{3} + e_2)$, which may have all values between 2α and α . The case corresponds to 11D, in which it passes for $e_1 = e_2 > 0$; if $e_2 < 0$ there is no corresponding degenerated case.

Two roots are conjugate complex. The value which in (25) is possible for is is 0. Then z varies from ∞ to e_2 and back. So if $e_2 \geq \frac{2}{3}$ this case is impossible. If $-\frac{1}{3} < e_2 < \frac{2}{3}$, z varies between $\frac{2}{3}$ and e_2 , φ between a value φ_3 for which

$$\mathcal{P}\left(\frac{1}{2}\varphi_3\right) = \frac{2}{3}$$

(situated between 0 and $2\omega_3$) and $4\omega_2 - \varphi_3$. r changes from α to $\alpha/(\frac{1}{3} + e_2)$, which may have any value $> \alpha$, and then returns to α . This case can pass into 10, if e_1 and e_3 approach to the same negative value: and, if e_2 becomes negative, it may divide itself into 11B on the one hand and 11C or 11D on the other (11C if $e_2 < -\frac{1}{3}$, 11D if $e_2 > -\frac{1}{3}$).

We now have a survey of all possible motions. We must, however, remark that not all the motions take place with a velocity smaller than that of light, as in case of some of them (e.g. 11A and 12A) A and so also L is negative. We have not separately mentioned all those cases. In 11 e.g. $\alpha^2 < \frac{1}{3}$, means that the velocities are smaller than that of light. In 12 for that purpose $e_1 e_2 + e_2 e_3 + e_3 e_1$ has to be $> -\frac{1}{3}$.

13. It is now necessary to consider the place taken up in this survey by the well-known motions of the planets and comets. These motions all take place with small velocities; we will call a quantity

such as the square of the velocity of a planet, a quantity of the first order. In NEWTON'S theory, which accounts very exactly for the motions, $\alpha \cdot r$ is found to be of the same order as the square of a velocity; this we take from NEWTON'S theory. In (13) A must then be a quantity, differing little from 1; we represent it by

$$A = 1 + \frac{\mu\alpha}{\lambda^2}.$$

In (14) B is a quantity of order $\frac{1}{2}$. We represent it by

$$B = \sqrt{\alpha} : \lambda$$

and take λ positive. The constants λ and μ then take the places of A and B . If we substitute these constants in (21), this equation becomes

$$\frac{\lambda^2}{r} \cdot \frac{1}{1 - \frac{\alpha}{r}} - \frac{1}{1 - \frac{\alpha}{r}} \frac{1}{r^4} \left(\frac{dr}{d\varphi} \right)^2 - \frac{1}{r^2} = \mu. \quad \dots \quad (21a)$$

The constants λ and μ are moderately great. The formula passes into the corresponding one of NEWTON'S theory, if we put $\alpha = 0$. We then obtain

$$\frac{\lambda^2}{r} - \frac{1}{r^4} \left(\frac{dr}{d\varphi} \right)^2 - \frac{1}{r^2} = \mu \quad \dots \quad (21b)$$

The equation gives rise to an ellipse, if μ is positive, to a parabola if $\mu = 0$, to a hyperbola if μ is negative. In NEWTON'S theory $4\mu < \lambda^4$. In consequence of the introduction of the constants λ and μ the equations pass into

$$x_1 + x_2 + x_3 = 1 \quad x_1 x_2 + x_2 x_3 + x_3 x_1 = \alpha(\lambda^2 + \mu\alpha), \quad x_1 x_2 x_3 = \mu\alpha^2. \quad (22a)$$

We see from these that the roots x_1, x_2, x_3 approach very nearly to 1,0,0. The quantity $\alpha(\lambda^2 + \mu\alpha)$ is positive. Because $\mu < \frac{1}{4}\lambda^4$ the roots prove to be all real. x_1 is somewhat smaller than 1, about $\alpha\lambda^2$, x_2 and x_3 are of the order of α ; they are both positive if μ is positive, else they have opposite signs; x_3 becomes zero if $\mu = 0$. We will therefore put

$$\begin{aligned} x_1 &= 1 - 2am, \\ x_2 &= \alpha(m + n), \\ x_3 &= \alpha(m - n). \end{aligned}$$

Now $x_1 + x_2 + x_3 = 0$ as it ought to be; if $n < m$ we have to deal with the quasi-elliptic motion, if $n > m$ with the quasi-hyper-

bolic, if $n = m$ with the quasi-parabolic. The constants m and n take the places of λ and μ . We obtain

$$\left. \begin{aligned} e_1 &= \frac{2}{3} - 2\alpha m, \\ e_2 &= -\frac{1}{3} + \alpha(m+n), \\ e_3 &= -\frac{1}{3} + \alpha(m-n) \end{aligned} \right\} \dots \dots \dots (34)$$

In (22) and (26) we now must take, in the case of elliptic motion, $is = \omega_3$, as φ increases indefinitely, z remaining finite. In the case of the parabolic and hyperbolic motion r becomes infinite and so $z = -\frac{1}{3}$; z moves between e_3 and e_2 and again $is = \omega_3$. So (26) becomes

$$\frac{\alpha}{r} = \frac{1}{3} + \mathcal{P}(\frac{1}{2}\varphi + \omega_3).$$

Now we have the formula

$$\mathcal{P}(\frac{1}{2}\varphi + \omega_3) = e_3 + \frac{(e_1 - e_3)(e_2 - e_3)}{\mathcal{P}\frac{1}{2}\varphi - e_3}$$

and so

$$\frac{\alpha}{r} = \frac{1}{3} + e_3 + \frac{(e_1 - e_3)(e_2 - e_3)}{\mathcal{P}\frac{1}{2}\varphi - e_3},$$

or from (34)

$$\frac{1}{r} = m - n + 2n \frac{e_1 - e_3}{\mathcal{P}\frac{1}{2}\varphi - e_3} \dots \dots \dots (35)$$

This is the equation of the orbit required. If we now let α become zero, e_3 and e_2 coincide, $e_1 - e_3$ becomes 1, and the \mathcal{P} -function degenerates. We then obtain

$$\frac{1}{r} = m - n + 2n \sin^2 \frac{1}{2}\varphi = m - n \cos \varphi \dots \dots (35a)$$

and this equation shows once more that, if $\alpha \neq 0$, for $n < m$ the motion is (quasi-)elliptic, for $m > n$ (quasi-)hyperbolic, for $n = m$ (quasi-)parabolic. For $n = 0$ it is circular, also if α is not supposed to be zero. The elliptic case is case 12 C, the hyperbolic is 12 B, the parabolic is 12 B, e_3 being supposed to be $-\frac{1}{3}$ there.

14. Let us now examine the motion of the planets a little more in detail. Equation (35) shows that $4\omega_1$ is the period; as the \mathcal{P} -function is almost degenerated we may take

$$4\omega_1 = \frac{4\pi}{\sqrt{e_1 - e_3} + \sqrt{e_1 - e_2}} \dots \dots \dots (36)$$

A further approximation is not necessary as, after expanding the

roots in a series of ascending powers of α , the terms of degree 0 and 1 do not change any longer. From (36) it follows in this way

$$4\omega_1 = 2\pi \left(1 + \frac{3}{2} \alpha m\right) = 2\pi + 3\alpha m\pi.$$

Now (35) shows that $m - n$ is the smallest, $m + n$ the greatest value of $\frac{1}{r}$. From this or from (35a) it follows that m is the reciprocal value of the parameter p of the orbit and n/m represents the excentricity; so

$$e = \frac{n}{m}, \quad p = \frac{1}{m} \dots \dots \dots (37)$$

This gives for the motion of the perihelion per period $3\alpha\tau/p$ corresponding to the value calculated by EINSTEIN.

To conclude we will calculate the periodic time. From (14) follows

$$Bdt = \frac{r^2 d\varphi}{1 - \frac{\alpha}{r}}$$

If we put in this $\alpha = 0$ we obtain the corresponding equation of NEWTON'S theory; we may therefore expand the denominator and obtain as a first approximation

$$Bdt = r^2 \left(1 + \frac{\alpha}{r}\right) d\varphi = r^2 d\varphi + \alpha r d\varphi \dots \dots (38)$$

We must now substitute for r the value taken from (35). Let us for a moment introduce the elliptic function sn with the modulus k , defined by

$$k^2 = \frac{e_2 - e_3}{e_1 - e_3} = \frac{2\alpha n}{1 - 3\alpha m + \alpha n} \dots \dots \dots (39)$$

(35) passes into

$$\frac{1}{r} = m - n + 2n sn^2 \frac{1}{2}\varphi \sqrt{e_1 - e_3}; \dots \dots \dots (40)$$

k^2 is of the first order, and consequently very small. If we put

$$\sin \psi = sn \frac{1}{2}\varphi \sqrt{e_1 - e_3}, \dots \dots \dots (41)$$

we find by differentiation

$$\cos \psi d\psi = \frac{1}{2} \sqrt{e_1 - e_3} \sqrt{(1 - \sin^2 \psi)(1 - k^2 \sin^2 \psi)} d\varphi$$

or

$$\frac{1}{2} \sqrt{e_1 - e_3} d\varphi = \frac{d\psi}{\sqrt{1 - k^2 \sin^2 \psi}}$$

Now as (40) passes into

$$\frac{1}{r} = m - n + 2n \sin^2 \psi,$$

(38) becomes

$$\frac{1}{2} B \sqrt{e_1 - e_3} dt = \frac{d\psi}{(m-n+2n\sin^2\psi)^2 \sqrt{1-k^2\sin^2\psi}} + \frac{\alpha d\psi}{(m-n+2n\sin^2\psi) \sqrt{1-k^2\sin^2\psi}}$$

If $\alpha = k = 0$ we pass into NEWTON'S theory. So in the first fraction we may expand the denominator and neglect k^4 , etc., and in the second fraction we may put $k = 0$. Putting $k^2 = 2an$ in the first fraction we obtain

$$\begin{aligned} \frac{1}{2} B \sqrt{e_1 - e_3} dt &= \frac{1 + an\sin^2\psi}{(m-n+2n\sin^2\psi)^2} d\psi + \frac{\alpha d\psi}{m-n+2n\sin^2\psi} \\ &= \frac{1 - \frac{1}{2}\alpha(m-n)}{(m-n+2n\sin^2\psi)^2} d\psi + \frac{\frac{3}{2}\alpha d\psi}{m-n+2n\sin^2\psi} \end{aligned} \quad (42)$$

From the values of x_1, x_2, x_3 we get, considering (22),

$$B \sqrt{e_1 - e_3} = \sqrt{\frac{\alpha}{2m} \left(\frac{1 - 3am + an}{1 - 2am + \alpha^2(m^2 - n^2)} \right)^{\frac{1}{2}}}$$

We may write

$$B^{-1} (e_1 - e_3)^{-\frac{1}{2}} = \sqrt{\frac{2m}{\alpha} [1 + \frac{1}{2}\alpha(m-n)]}$$

and so (42) passes into

$$\frac{1}{2} \sqrt{\frac{\alpha}{2m}} dt = \frac{d\psi}{(m-n+2n\sin^2\psi)^2} + \frac{\frac{3}{2}\alpha d\psi}{m-n+2n\sin^2\psi}$$

We will call the time in which r is periodic the periodic time; it is the time in which φ increases by $4\omega_1$ and ψ by π . So

$$\begin{aligned} \frac{1}{2} \sqrt{\frac{\alpha}{2m}} T &= \int_0^\pi \frac{d\psi}{(m-n+2n\sin^2\psi)^2} + \frac{1}{2}\alpha \int_0^\pi \frac{d\psi}{m-n+2n\sin^2\psi} = \\ &= \frac{\pi m}{(m^2 - n^2)^{3/2}} + \frac{\frac{3}{2}\alpha\pi}{(m^2 - n^2)^{\frac{1}{2}}} \end{aligned}$$

In connection with (37) we get from this, a representing half the major axis:

$$\frac{\sqrt{a}}{2\pi\sqrt{2}} T = a^{\frac{3}{2}} + \frac{3}{2} \alpha a^{\frac{1}{2}},$$

or with the same degree of approximation

$$\frac{\sqrt{a}}{2\pi\sqrt{2}} T = (a + \alpha)^{\frac{3}{2}}.$$

We so obtain instead of KEPLER'S third law

$$\frac{(a + \alpha)^3}{T^2} = \frac{a}{8\pi^2} \dots \dots \dots (43)$$

We can also ask after the time required by φ to increase by 2π . This time depends on the place from which the planet starts; it is

greatest for the perihelion, smallest for the aphelion. As a mean value of all these times we may consider

$$T_1 = T \left(1 - \frac{3a}{2p} \right).$$

For this time KEPLER'S third law becomes

$$\left(a - \frac{ae^2}{1-e^2} \right)^3 : T_1^2 = \frac{a}{8\pi^2}.$$

This deviates from KEPLER'S law less than (43).

Chemistry. — "*The Metabolism of Aspergillus niger.*" By Dr. H. J. WATERMAN. (Communicated by Prof. J. BOESEKEN.)

(Communicated in the meeting of May 27, 1916.)

In researches described in previous communications ¹⁾ I have demonstrated that the quantity of different elements accumulated in the cells of *Aspergillus niger* is subject to very great variations. The investigation was carried out quantitatively for carbon, nitrogen and phosphorus and qualitatively for the element sulphur. Whereas from 100 parts by weight of carbon, assimilated as glucose, 55 parts, for instance, are absorbed after three days in the fungous material, this after 21 days amounts to only 31, so not quite 60% of the quantity originally taken up. The same applies to the nitrogen and particularly to the phosphorus in a still higher degree.

The quantity of nitrogen present in the cells falls in course of time to $\frac{2}{5}$ — $\frac{1}{3}$ of the quantity present in the young cells and with phosphorus even to $\frac{1}{7}$ — $\frac{1}{10}$. Also the sulphur is accumulated in young cells. On increasing age the superfluous quantities of the said elements are excreted.

On account of experimental difficulties I have given up the idea of determining the progressive course of the hydrogen and the oxygen separately, but have now decided to calculate the sum of these two elements accumulated in different periods in the fungous material. For, if we know the quantity of dry substance, likewise the percentage of carbon, nitrogen, phosphorus and ash, it is possible to determine with sufficient accuracy for my purpose the joint amount of hydrogen and oxygen.

¹⁾ Folia microbiologica, Holländische Beiträge zur gesamten Microbiologie I, 422 (1912); These Proceedings November 30 (1912) p. 753, February 22 (1913) p. 1047 and 1058, March 22 and April 25 (1913) p. 1349; Handelingen XlVe Ned. Natuur- en Geneesk. Congres p. 125.

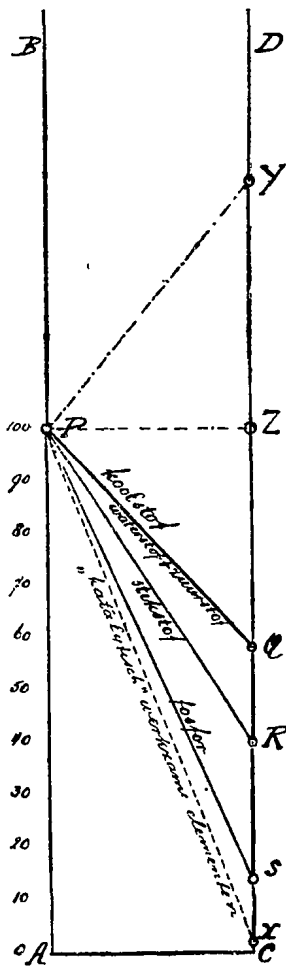

After 4 days. After 21 days.
 koolstof = carbon
 waterstof + zuurstof = hydrogen + oxygen
 stikstof = nitrogen
 fosfor = phosphorus
 katalytisch werkzame elementen = catalytically active elements

I have noticed that just as in the case of carbon, the quantity of hydrogen and oxygen present in a young fungous film diminishes in course of time and after 21 days has already fallen to about one half of the original quantity. In the figure this is represented graphically. On the vertical axis *AB* is indicated the quantity of the elements present in a young fungous film obtained under definite circumstances. This quantity is, of course, very unequal with different elements, large with carbon, small with phosphorus. If we assume that *AP* represents the quantity of each of the elements concerned in a young fungous film (4 days old), *CQ*, *CR*, *CS* etc. represent, respectively the quantity of carbon and hydrogen + oxygen, nitrogen, phosphorus etc. present in the 21 days old fungous film. $CQ = \pm \frac{1}{2} AP$, $CR = \pm \frac{2}{3} AP$, $CS = \pm \frac{1}{3} AP$.

The lines *PQ*, *PR* and *PS* then represent the diminution of the quantity of the correlated elements when the fungous material gets older. As demonstrated previously ¹⁾ they are in reality not straight but curved.

The utilization of the intermediate products present in the young cells in which process carbon dioxide, ammonia, phosphate, sulphate etc. are formed, explains the entire phenomenon. It is remarkable that many of the excreted products can again serve as nutrient so that for instance a small quantity of phosphorus can participate a few times in the metabolism of many cells.

I already expressed my opinion some time ago that there are also elements that will exhibit this phenomenon in a still higher degree than the phosphorus. These then go and resemble catalytically active elements (line *PX*). That the accumulation phenomenon does not remain confined to the elements carbon, hydrogen, oxygen,

¹⁾ Purposely I have united here the said lines in a graphic representation because they are related and descend *simultaneously*.

nitrogen, phosphorus and sulphur is shown from the determination of the sulphated ash from the fungous material at different periods of the development.

50 cc. of a nutrient liquor of the composition: tapwater, 2% anhydrous glucose, 0.3% NH_4NO_3 , 0.3% KH_2PO_4 and 0.2% of crystallised magnesium sulphate was inoculated with traces of *Aspergillus niger*. With the fungous material obtained after 47 days at 32°—33°, which was then washed with distilled water, a sulphated ash determination was made. All the glucose was used up. I obtained in four cases 5, 5, 5.5 and 6 mgs of ash, respectively (table 1). Such a trifling quantity of ash made us already expect that the elements occurring in the sulphated ash would be present in young cells in larger quantities than in old ones. The proof therefore is given by the further experiments mentioned in table I.

TABLE I.

Nutrient liquor: 50 cc. of tapwater wherein dissolved 2% anhydrous glucose, 0.15% NH_4NO_3 , 0.15% KH_2PO_4 , 0.1% crystallised magnesium sulphate. Inoculated with *Aspergillus niger*. Temperature during cultivation 32/33° C. Quantity of ash¹⁾ in mg., after moistening the fungus material with strong sulphuric acid²⁾.

NUMBER OF DAYS AFTER INOCULATION.				
Four	Nine		Sixteen	Forty seven ³⁾
<u>16</u>	<u>9</u>	<u>9</u>	<u>7</u>	<u>5</u>
<u>15</u>	<u>8</u>	<u>9</u>		<u>5</u>
<u>18</u>	<u>9</u>	<u>10</u>		<u>5,5</u>
	<u>11</u>	<u>9</u>		<u>6</u>

On the ground of the above it was to be expected that if we remove a young, only just formed, fungous film from the nutrient liquor and place it on distilled water after having first washed away the adhering fluid, the utilisation of the intermediate products will go on to a considerable degree if, at least, the temperature does not alter (32°—33°). Yet the matter was not quite so simple as I suspected. The possibility existed that one or more of the elements are accumulated not in the young but in the old cells

¹⁾ Ash entirely free from carbon.

²⁾ The figures with the same number of underlines belong to the same experimental series.

³⁾ In these experiments the inorganic nutriment was: 0,3% NH_4NO_3 , 0,3% KH_2PO_4 and 0,2% crystallised magnesium sulphate.

(line *P Y*). In this case the element, whether added purposely or not ought to be present in the liquid. At a possible non-presence the ordinary utilisation of the intermediate products with the other elements would be retarded or even not take place at all, at least if the said element should have an *essential* and not a subordinate significance for the metabolism. Experiments in connexion herewith have, however, shown that such an element does not exist (See Table II).

TABLE II.

50 cc. of nutrient liquor composed of tapwater in which is dissolved 2 % anhydrous glucose, 0.15% NH_4NO_3 , 0.15% KH_2PO_4 , and 0.1% crystallised magnesium sulphate. Temp. 33°. Inoculated with *Aspergillus niger*.
Dry substance in mg (dried at 105° to constant weight).

After 4 days ¹⁾	After 5 days ¹⁾	After 5 days ¹⁾ of which the last day on dist. water	After 7 days ¹⁾ , of which the last three days on dist. water
436	367	368	341
439		353	314
			315

For the utilisation of the intermediate products and the consequent decrease of the quantity of dry substance an absorption of any element from the nutrient liquor is thus no longer essential²⁾ in the normal metabolism of *Aspergillus niger*. All elements needed for the metabolism of *Aspergillus niger* are accumulated in the young fungous material and when this gets older they are partly excreted³⁾.

Elements that are permanently accumulated, whilst the cells are growing older, do not exist.

Dordrecht, May 1916.

¹⁾ All the glucose is consumed.

²⁾ The element oxygen is excluded here.

³⁾ Represented in the Fig. by the lines *PQ*, *PR*, *PS*, *PX* etc *PZ* is a particular but improbable case.

Anatomy. — “*The ape fissure — sulcus lunatus — in man*”. (By Dr. D. J. HULSHOFF POL). (Communicated by Prof. C. WINKLER).

(Communicated in the meeting of May 27, 1916).

On the appearance of an ape fissure in man, opinion is still divided.

While e.g. KOHLBRUGGE¹⁾ considers himself obliged to accept that the latter is only found in apes, ELLIOT SMITH²⁾ comes to the conclusion that the sulcus lunatus, described by him, is nothing else but the fissura simialis in apes and that this fissure constantly appears (a constant feature of the human brain).

It is, superficially seen, quite remarkable, that such a great difference in opinion exists about the appearance or not of such an importantly developed fissure.

The reason of it has to be looked for in the fact, primarily, that it is especially difficult to homologise at the occipital pole the sulci of apes with those of men, secondarily, because no count has been kept with the development of the fissura simialis in embryos of primates.

When one does not carefully examine where and how the fissura simialis develops in embryos, it will always remain a fruitless work to discuss whether between the manifold sulci and fissures on the posterior part of the human brain one can be found, which could be placed on the same level with the fissura-simialis in primates.

In my record on the development of this fissure⁴⁾ and its relation to the “*plis de passage*”⁵⁾ I explained:

- a. that the ape fissure is a *non-constant* fissure,
- b. that it is formed in foetal life, *after* the other sulci are already present,
- c. that it is formed by *the same* ape species always nearly on *the same* spot,
- d. that it can be formed in different ape species at different places,
- e. that the characteristics, by which it can be recognised from the other sulci, in the different ape species, can be totally *different*.

// If we therefore want to investigate whether in man an ape fissure is present, then one has to take with the previous results into account.

In *semnopithecii* I pointed out that in first instance the sulci are formed on the brain surface and that only afterwards, when a larger growth of the occipital part should take place, a curvature appears, which is to be taken as the beginning of the fissure. It is now the question, whether in man the same relation may be expected.

When I do not go back further than nearly half a century, ECKER⁶⁾ laid stress on the fact, that in the 9th month of foetal life all the principal sulci and principal gyri are already formed, but that the subsulci and subgyri are still missing for a great part (p. 222 sub 14). If therefore an ape fissure should be formed, then this will, being an important sulcus, be formed during foetal life.

RETZIUS came just to the same conclusion, who added to it (p. 27), that in a sufficient number of specimens out of this foetal period, one can find all the varieties, which appear on the brainsurface of adult human beings.

This report therefore also points out that in case an ape fissure should be there, it has to be demonstrated in foetal life.

The above mentioned agrees with what is found in apes, and the ape fissure in man therefore will also be best examined on foetal brains. Moreover it is of great profit that the complex of sulci before birth is not yet as complicated as in the adult state.

From the embryology, which ECKER gives to us, it appears that the development of all the principal sulci can be distinctly followed, but that there is not one among them, which leads us to suppose it the ape fissure. As the sulci till the beginning of the 9th month show a simple type, it is not difficult to come to a similar conclusion.

The only exception could possibly be made by his transitory sulci, of which some run transversally on the posterior lobe. These however cannot be compared with an ape fissure, because they are only of temporary nature and disappear in the 4th and 5th months.

RETZIUS too, who neither speaks of an ape fissure in foetal life in the embryology, described by him, does not think these transitory sulci of great importance. He e.g. points out (p. 16) that in judging the value of these sulci one has to be very careful, as a great number of the young abortised embryos carry the sign of being abnormal, what naturally has to be found back in the brains.

I believe that RETZIUS has given hereby a very important fact for the development of these sulci and it is therefore necessary not to value highly these transitory sulci.

On the other hand RETZIUS intends to draw especially attention to a sulcus, which runs from the medial junction of the fissurae parieto-occipitalis and calcarina on the lateral occipital surface. Plate XXVI, fig. 2, 3 and 4.

If one examines this sulcus, which is also drawn on page XXII, fig. 2 and plate XIII, fig. 8 and 9. then this shows a great resemblance with an ape fissure. The only thing is, that it is found in

brains, in which the other principal sulci had not yet reached their full development, so that the question remains whether not a transitory sulcus was present. RETZIUS too takes it in that way (s. description Plate XIII).

Excepting ECKER and RETZIUS, I could not find, reading through other literature, anything that indicates a fissura simialis in human embryos either.

The only exception might have been the report of KOHLBRUGGE²), who writes on p. 243: "Die Affenspalte beim Menschen halte ich also für eine im embryonalen Leben sich bildende Anomalie". This would mean, that he has found in the unborn fruit a sulcus, which should be taken for an ape fissure. As I could not find in the communications written by KOHLBRUGGE anything more in particular about this sulcus, and the question is of great importance, I addressed him personally and I received the answer, that he himself never saw such a sulcus in human foetus, but from analogy with what was found in apes, he did not want to exclude the possibility, that in man, during foetal life an ape fissure might be formed.

Summarizing what previously has been said, one must come to the conclusion that the study of the human embryos and foeti does not teach us anything about the commencement of the ape-fissure.

If one holds to the analogy in development of the sulci in men and apes, then the above said would suffice to conclude that in man no ape fissure is formed.

This consequence therefore presents itself, because we know, — in a previous report I called attention to it⁶) —, that the ape fissure in anthropoids is already much less developed than in *semnopithec*i and *macac*i.

It is therefore not strange in itself, that in human brains, which in the range of development are placed much higher than those of the anthropoids, the ape fissure does not come to development.

However while even in recent years ELLIOT SMITH and others have defended the conviction, that in man an ape fissure is surely found, I will accept for a moment, that the fissura simialis, contrary to the other principal fissures, is formed in man only after foetal life.

And I will accept this the sooner, as I showed sub *d* and *e*, that in the different ape species, this sulcus can be formed at different places and that the characteristics of these different sulci, need not be the same.

The possibility therefore is not, theoretically spoken, excluded that in man this fissura is formed under totally different circumstances, e.g. only after foetal life.

Accepting the latter, I shall examine whether the sulcus lunatus, described by ELLIOT SMITH, answers the requirements which are due to an ape fissure, it being moreover accepted as granted, that not every sulcus on the occipital pole of the brain can be called an ape fissure. It will therefore need some characteristics, by which it can be differentiated from other sulci.

This is the more necessary, as it is known to us, that the sulci on the lobus occipitalis show such a varying picture that to distinguish the most familiar fissurae already gives rise to difficulty. Thus WALDEIJER wrote: "Es gelang RETZIUS ebenso wenig wie seinen Vorgängern, eine typische Anordnung der Furchen und Windungen am Hinterlappen des Grosshirns nachzuweisen: derselbe wird also noch bis auf weiteres die Crux der Hirnanatomie nach dieser Seite hin bleiben".

It is also known that at the occipital pole through the transversally and obliquely running sulci one can find, gyri, which possess the likeness to an operculum. This "Halbringform" is described a.o. by RETZIUS on page 136, where the fissura calcarine continues on the lateral brainmantle, forming a "nach vorn-oben vorhängendes operculum."

These, let me call them *pseudo-opercula*, therefore do not develop by overgrowth, but by a confluence, or more by an oblique course of ordinary sulci.

We could compare it with a ball, of which the half of a superficial segment is cut in, forming thus a thing that looks like a fictitious operculum, a "Klappdecke".

The presence therefore of a thing that in man resembles an operculum, does not give a right to speak of an ape-fissure. This too ELLIOT SMITH⁸⁾ admits, when he writes on page 448 "...especially the sulcus occ. transversus may have a caudal opercular lip, which simulates the true stria-bearing occipital operculum".

Where this mighty means to determine an ape-fissure, falls away, there only a few characteristics remain, which can be helpful in identifying this sulcus.

The *first* is the pushing inwards or overgrowing of sulci, which under normal circumstances remain on the surface.

It speaks for itself that in connection with the previous question, it is not always very easy to make out whether a sulcus is pushed to the depth either through overgrowth of an adjoining part, or whether the arisen relation is the result of a confluence which is so often seen on the brain surface. Moreover it often happens that sulci which for the greater part are lying on the surface, can be

removed so far, that they, as it were, come to be lying in another sulcus.

In short to mention an example, KOHLBRUGGE²⁾ writes on page 70 "Auf XXI und XXII liegt der Diagonalis in der Tiefe, eingebettet in den vorderen Rand des s. praec. inf."

In *semnopithec*i and *macac*i it is different: there one finds the $m + m'$ sulcus (par. occ. lat. seu occ. transversus) on the surface. In case there is an ape fissure then that total sulcus, the caudal part of the $l + e$ sulcus (s. interparietalis) included is *pushed in a newly arisen sulcus*.

If one opens the fissure, one always finds the $m + m'$ sulcus in it. This is quite distinctly indicated in fig. II of ZUCKERKANDI's³⁾ communication.

Such striking proofs for the recognition of an ape fissure are missed in the communications of ELLIOT SMITH and MURPHY¹⁰⁾, so that I am justified in accepting that they did not find this proof present.

The *second* characteristic one could find in the "plis de passage".

I pointed out⁵⁾ that the "plis de passage" primarily are lying on the surface and only secondarily are pushed down to the depth.

Now it is not always very easy to make out whether a part of the cortex, which one finds in the depth is lying under normal circumstances on the surface. Yet it is comprehensible that under certain circumstances this can be possible, as we have seen in ape embryos.

ELLIOT SMITH does not make use of these "plis de passage" to demonstrate, that his sulcus lunatus is an ape-fissure.

The *third* characteristic could be sought in the localisation of the fissure.

In a former communication⁴⁾ I came to the conclusion, that the ape-fissure developed through augmented growth of the lobus occipitalis. As this will take place in apes of the same species always in nearly the same way, therefore too the ape fissure in the same species of apes will be formed on nearly the same place. One can understand, that when in men a *true* operculum is formed on the lobus occipitalis, this always must be found at nearly the same distance from neighbouring sulci.

ELLIOT SMITH describes to us the localisation of his sulcus lunatus on page 448 in this way:

"The sulcus lunatus is subjected to a very wide range of variation in the human brain . . . The sulcus lunatus may extend right across the lateral aspect of the hemisphere from the dorso-mesial to the ventro-lateral edge, as in most chimpansees. It may be a much

shorter furrow placed anywhere between these two extremes. It may be transverse, oblique or horizontal in direction. It is very frequently interrupted by a submerged "gyrus translunatus": and occasionally this gyrus comes to the surface and completely divides the lunate sulcus into a pars dorsalis and a pars ventralis. Either of these furrows may be joined to a sulcus praelunatus so as to form a pattern, which is at first sight somewhat perplexing."

I thought, it necessary to copy the whole of the description given by E. SMITH to make distinctly clear that in this way each sulcus on the occipital pole can be taken for a sulcus lunatus.

ELLIOT SMITH came to this description of the localisation of his sulcus lunatus, because this should form a border of the surface, over which the stria Gennari (Stria of VICQ. D'AZYR) should extend.

This conception of ELLIOT SMITH proved to be wrong later on. Not only does he himself already write on p. 440 that in many cases the area striata is always sufficiently near to the sulcus lunatus, which does not point distinctly to a border, but moreover the investigations e.g. of BRODMANN¹¹⁾ and MURPHY¹⁰⁾ make clear that in Europeans the area striata is in no way connected with the furrow which is described by E. SMITH as sulcus lunatus.

From the above said follows, that of all the characteristics, which an ape fissure could possess to be distinguished from the neighbouring furrows with regard to the sulcus lunatus of ELLIOT SMITH, not one is to be found which suffices. The sulcus lunatus, described by him, therefore can be brought back to pseudo-opercula, which frequently appear on the occipital pole and which are described e.g. by RETZIUS as "Halbringform".

CONCLUSIONS.

1. Where in anthropoids an ape fissure is still found, theoretically spoken, the possibility exists that in man too an ape fissure can develop.

2. Where in anthropoids the ape fissure is already importantly less developed than in semnopithecii, however the possibility also exists that a same furrow in men does not come into development.

3. In apes all the principal furrows develop, also the fissura simialis, during foetal life.

Where in man too all the principal furrows develop during foetal life, it may be accepted that in case an ape fissure should be formed, this should take place during foetal life.

4. However where in human foetus no ape fissure is found,

there it may be accepted, that also in the adult state no fissura simialis appears.

5. The sulcus lunatus, described by ELLIOT SMITH, for the rest possesses no properties which characterize it as an ape fissure.

6. The sulcus lunatus therefore is nothing but an ordinary sulcus or confluence of a few of them, by which a pseudo-operculum arises, thus a "Halbringform" in the sense of RETZIUS.

1. KOHLBRUGGE, J. H. F. Die Variationen an den Grosshirnfurchen der Affen mit besonderer Berücksichtigung der Affenspalte. Zeitschr. f. Morph. u. Anthrop. 1903.

2. Id. Die Gehirnfurchen der Javanen. Verhandelingen der Koninkl. Akademie v. Wetenschappen te Amsterdam. 1906.

3. SMITH, J. ELLIOT. The so-called "Affenspalte" in the Human (Egyptian) Brain. Anatomischer Anzeiger 1904.

4. HULSHOFF POL, D. J. The fissura simialis in embryos of semnopithecii. These Proc. XVIII p. 1571.

5. Id. The relation of the plis de passage of GRATIOLET to the ape fissure. These Proc. p 104.

6. ECKER, A. Zur Entwicklungsgeschichte der Furchen u. Windungen der Grosshirn-Hemisphären im Foetus des Menschen Archiv f. Anthropologie. 1868.

7. RETZIUS, GUSTAF. Das Menschenhirn. Stockholm. 1896.

8. SMITH, G. ELLIOT. The morphology of the Occipital Region of the Cerebral Hemisphere in Man and the Apes. Anat. Anzeiger. 1904.

9. ZUCKERKANDL, C. Zur Morphologie des Affengehirnes. Zeitschr. f. Morph. u. Anthrop. 1903.

10. MURPHY, J. B. Note on the sulcus lunatus in negro and white brains and its relation to the area striata. The anatomical Record. 1910.

11. BRODMAN, H. Histologische Lokalisation. Journal für Psychologie und Neurologie. 1905—1906.

Physics. — "*The currents arising in n -coupled circuits when the primary current is suddenly broken or completed.*" By BALTH. VAN DER POL Jr. (Communicated by Prof. W. H. JULIUS.)

(Communicated in the meeting of January 29, 1916.)

Suppose we have two circuits with given resistance and self-induction and coupled magnetically. If the electromotive force in one of the circuits suddenly stops, the current in it will asymptotically fall to a zero value, whereas the current in the other circuit rises from zero to a maximum value, then gradually falling again to zero.

This paper will treat on the following extension of this problem:

1. The change in time of the currents excited in n equal circuits coupled magnetically, in such a way that the first is coupled with the second, the second with the third, etc., the $n-1^{\text{th}}$ with the n^{th} .

15

Proceedings Royal Acad. Amsterdam, Vol. XIX.

2. The same problem; only the n^{th} being coupled with the first; so as to produce a closed chain of currents.

For the sake of simplicity we will put equal the coefficients of selfinduction and the resistances for all circuits; the same assumption being made for the coefficients of mutual induction.

I. *Linear series of coupled circuits.*

Our case of an electromotive force existing in the first circuit and disappearing suddenly at the time $t = 0$, is analytically equivalent to the case that at the time $t = 0$, the current is zero for all circuits except for the first where its value amounts to $i_1 = \frac{E}{r}$.

Putting the current in the first, second, third, etc. circuit i_1, i_2, i_3, \dots , etc., and the coefficients of selfinduction L , the coefficients of mutual induction M ; the resistances r , then we have the following set of simultaneous differential equations:

$$\left. \begin{aligned} i_1 r + L \frac{di_1}{dt} + M \frac{di_2}{dt} &= 0 \\ i_2 r + L \frac{di_2}{dt} + M \frac{di_3}{dt} + M \frac{di_1}{dt} &= 0 \\ i_3 r + L \frac{di_3}{dt} + M \frac{di_4}{dt} + M \frac{di_2}{dt} &= 0 \\ \dots &\dots \\ i_{n-1} r + L \frac{di_{n-1}}{dt} + M \frac{di_n}{dt} + M \frac{di_{n-1}}{dt} &= 0 \\ i_n r + L \frac{di_n}{dt} + M \frac{di_{n-1}}{dt} &= 0 \end{aligned} \right\} \dots \dots (1)$$

the initial condition being

$$\text{for } t = 0 \text{ is: } i_1 = \frac{E}{r}, i_2 = i_3 = \dots = i_n = 0$$

In order to obtain the solution we take

$$\begin{aligned} i_1 &= \alpha_1 e^{pt} \\ i_2 &= \alpha_2 e^{pt} \\ &\dots \\ i_n &= \alpha_n e^{pt} \end{aligned}$$

Further, introducing

$$\frac{r + pL}{Mp} = q \dots \dots \dots (2)$$

and substituting these expressions in the differential equations, we obtain the homogeneous equations

$$\left. \begin{aligned} q a_1 + a_2 &= 0 \\ a_1 + q a_2 + a_3 &= 0 \\ a_2 + q a_3 + a_4 &= 0 \\ \dots &\dots \\ a_{n-2} + q a_{n-1} + a_n &= 0 \\ a_{n-1} + q a_n &= 0 \end{aligned} \right\} \dots (3)$$

In order to obtain a possible solution, the determinant of these equations must be equal to zero

$$\Delta_n = \begin{vmatrix} q & 1 & 0 & 0 & \dots & 0 & 0 \\ 1 & q & 1 & 0 & & & 0 \\ 0 & 1 & q & 1 & & & \vdots \\ \vdots & & & & & & \vdots \\ 0 & & & & & 1 & q & 1 \\ 0 & 0 & \dots & 0 & 1 & q \end{vmatrix} = 0 \dots (4)$$

Putting:

$$q = 2 \cos \theta$$

we find for the determinant¹⁾

$$\Delta_n = \frac{\sin(n+1)\theta}{\sin \theta} = 0 \dots (5)$$

This equation can be fulfilled by

$$\theta_k = \frac{k\pi}{n+1} \dots (5a)$$

where

$$k = 1, 2, 3, \dots, n$$

the roots of (4) thus appearing to be

$$\left. \begin{aligned} q_1 &= 2 \cos \frac{\pi}{n+1} \\ q_2 &= 2 \cos \frac{2\pi}{n+1} \\ q_3 &= 2 \cos \frac{3\pi}{n+1} \\ \dots &\dots \\ q_k &= 2 \cos \frac{k\pi}{n+1} \\ \dots &\dots \\ q_n &= 2 \cos \frac{n\pi}{n+1} \end{aligned} \right\} \dots (6)$$

¹⁾ Comp. RAYLEIGH, The theory of sound, Vol. I, p. 172. The expression (5) for Δ_n can be obtained from goniometric formulae, and also from continuous fractions.

From this we find, with the help of (2) the n unequal roots of p_1, p_2, \dots, p_n .

Using formula (5) to calculate the determinants in the numerators in the expressions for $\alpha_1, \alpha_2, \dots, \alpha_n$, we find, after some simple reductions:

$$\begin{aligned} \alpha_1 &= C \sin \theta \\ \alpha_2 &= -C \sin 2\theta \\ \alpha_3 &= C \sin 3\theta \\ &\dots \\ \alpha_n &= (-1)^{n+1} C \sin n\theta \end{aligned}$$

C being an arbitrary constant.

Every α is a function of θ . Giving to θ one of the values of the set (5a) we obtain the coefficients α_{kl} , where the second index relates to the number of the root ($\theta = \theta_l$). For α_{kl} we have

$$\alpha_{kl} = \alpha_k = (-1)^{k+1} C \sin k \theta_l = (-1)^{k+1} C \sin \frac{kl}{n+1} \pi$$

$$\theta_l = \theta_l$$

whereas we have from (2) and (6)

$$p_k = \frac{-r}{L - M q_k} = \frac{-r}{L - 2M \cos \frac{k\pi}{n+1}}$$

From this we obtain ¹⁾ for the general solutions of (1)

¹⁾ The expressions obtained for the currents may also be found in the following way. The general differential equations have the form

$$r i_k + L \frac{d i_k}{dt} = -M \left(\frac{d i_{k+1}}{dt} + \frac{d i_{k-1}}{dt} \right)$$

Let us put

$$i_k = \chi \sin k\theta$$

where χ is a function of the time. Substituting this we find

$$\left(r\chi + L \frac{d\chi}{dt} \right) \sin k\theta = -2M \frac{d\chi}{dt} \sin k\theta \cos \theta$$

or

$$-r\chi = (L + 2M \cos \theta) \frac{d\chi}{dt} \dots \dots \dots (a)$$

From this we have

$$\chi = C e^{\frac{-r}{L+2M \cos \theta} t}$$

The form

$$i_k = C \sin k\theta e^{\frac{-r}{L+2M \cos \theta} t}$$

identically fulfils the first equation of the set (1), the n th from this set giving

$$pk = \frac{-r}{L - 2M \cos \frac{k\pi}{n+1}} = \frac{-r}{L - 2M \cos(kd\varphi)}$$

Therefore we obtain as the solution of an infinite number of coupled circuits,

$$i_1 = \frac{2}{\pi} \int_0^\pi \sin^2 \varphi e^{\frac{-r}{L-2M \cos \varphi} t} d\varphi$$

$$i_2 = \frac{2}{\pi} \int_0^\pi \sin \varphi \sin 2\varphi e^{\frac{-r}{L-2M \cos \varphi} t} d\varphi$$

.

$$i_k = \frac{2}{\pi} \int_0^\pi \sin \varphi \sin k\varphi e^{\frac{-r}{L-2M \cos \varphi} t} d\varphi$$

.

II. Closed cycle of coupled circuits.

Let us consider the same case, but now the n^{th} circuit be coupled with the first. Then the currents in the various circuits will be determined by the following set of simultaneous linear differential equations:

$$\left. \begin{aligned} i_1 r + L \frac{di_1}{dt} + M \frac{di_2}{dt} + M \frac{di_n}{dt} &= 0 \\ i_2 r + L \frac{di_2}{dt} + M \frac{di_3}{dt} + M \frac{di_1}{dt} &= 0 \\ i_3 r + L \frac{di_3}{dt} + M \frac{di_4}{dt} + M \frac{di_2}{dt} &= 0 \\ \dots \dots \dots & \dots \dots \dots (9) \\ i_n r + L \frac{di_n}{dt} + M \frac{di_1}{dt} + M \frac{di_{n-1}}{dt} &= 0 \end{aligned} \right\}$$

Substituting in the same way

$$\begin{aligned} i_1 &= \alpha_1 e^{\rho t} \\ i_2 &= \alpha_2 e^{\rho t} \\ \dots & \dots \dots \dots \\ i_n &= \alpha_n e^{\rho t} \end{aligned}$$

and further

b. if $n' = \text{odd}$

$$\begin{aligned}
 i_{n'} &= C_1 \sin \frac{1}{2} n' \pi \cdot e^{p_1 t} + C_2 \sin \frac{1}{2} (n'+2) \pi \cdot e^{p_2 t} + \dots + C_{\frac{n'+1}{2}} \sin \frac{1}{2} (2n'-1) \pi \cdot e^{\frac{p_{n'+1} t}{2}} \\
 i_{n'-1} = i_1 &= \left\{ C_1 \sin \frac{1}{2} n' \pi \cdot e^{p_1 t} + C_2 \sin \frac{1}{2} (n'-1) \frac{n'+2}{n'} \pi \cdot e^{p_2 t} + \dots + C_{\frac{n'+1}{2}} \sin \frac{1}{2} (n'-1) \frac{2n'-1}{n'} \pi \cdot e^{\frac{p_{n'+1} t}{2}} \right\} \\
 i_{n'-2} = i_2 &= C_1 \sin \frac{1}{2} (n'-2) \pi \cdot e^{p_1 t} + C_2 \sin \frac{1}{2} (n'-2) \frac{n'+2}{n'} \pi \cdot e^{p_2 t} + \dots + C_{\frac{n'+1}{2}} \sin \frac{1}{2} (n'-2) \frac{2n'-1}{n'} \pi \cdot e^{\frac{p_{n'+1} t}{2}} \\
 &\dots \dots \dots \\
 \frac{i_1}{\frac{1}{2} n' + \frac{1}{2}} = i_1 = \frac{i_1}{\frac{1}{2} n' - \frac{1}{2}} &= (-1)^{\frac{1}{2} n' - \frac{1}{2}} \left\{ C_1 \sin \frac{1}{2} \pi \cdot e^{p_1 t} + C_2 \sin \frac{1}{2} \frac{n'+2}{n'} \pi \cdot e^{p_2 t} + \dots + C_{\frac{n'+1}{2}} \sin \frac{1}{2} \frac{2n'-1}{n'} \pi \cdot e^{\frac{p_{n'+1} t}{2}} \right\}
 \end{aligned} \tag{15b}$$

The circuit of the index n is evidently the one, in which at the instant ($t = 0$) the original current has been stopped.

Introducing the initial conditions

$$\text{for } t = 0 \quad i_1 = i_2 = \dots = i_{n-1} = 0 \quad \text{and} \quad i_n = \frac{E}{r}$$

we obtain the following set of linear equations determining the constants C ,

$n = \text{even}$:

$$\begin{aligned}
 C_1 \cos \frac{1}{2} n \pi &+ C_2 \cos \frac{1}{2} (n+2) \pi &+ \dots + C_{\frac{n+2}{2}} \cos n \pi &= \frac{E}{r} \\
 C_1 \cos \left(\frac{1}{2} n - 1\right) \pi &+ C_2 \cos \left(\frac{1}{2} n - 1\right) \frac{n+2}{n} \pi &+ \dots + C_{\frac{n+2}{2}} \cos \left(\frac{1}{2} n - 1\right) 2\pi &= 0 \\
 C_1 \cos \left(\frac{1}{2} n - 2\right) \pi &+ C_2 \cos \left(\frac{1}{2} n - 2\right) \frac{n+2}{n} \pi &+ \dots + C_{\frac{n+2}{2}} \cos \left(\frac{1}{2} n - 2\right) 2\pi &= 0 \\
 &\dots \dots \dots \\
 C_1 \cos \pi &+ C_2 \cos \frac{n+2}{n} \pi &+ \dots + C_{\frac{n+2}{2}} \cos 2\pi &= 0 \\
 C_1 \cos 0 &+ C_2 \cos 0 &+ \dots + C_{\frac{n+2}{2}} \cos 0 &= 0
 \end{aligned} \tag{16a}$$

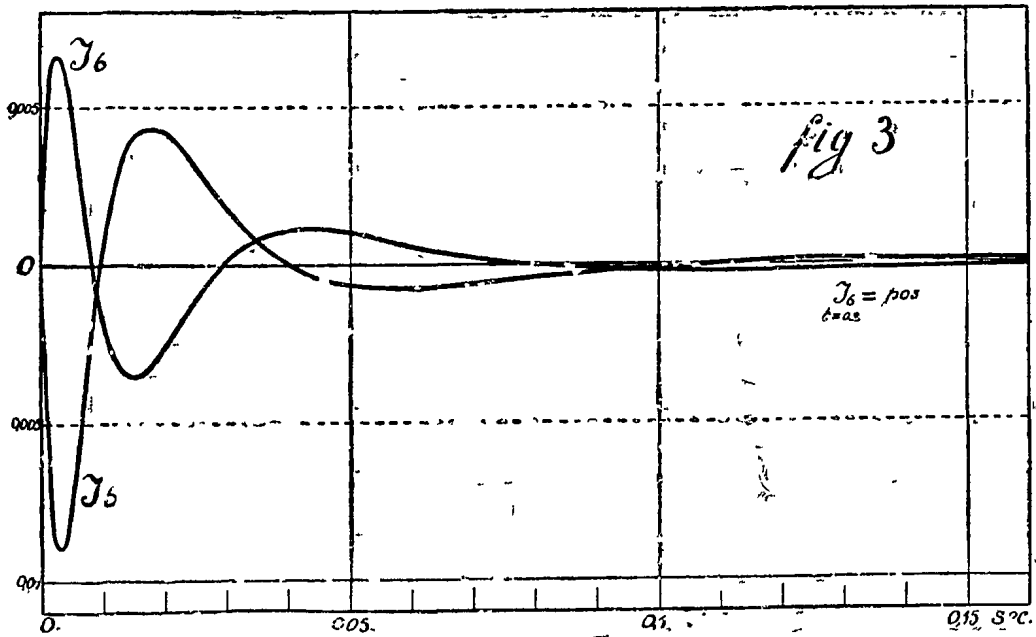
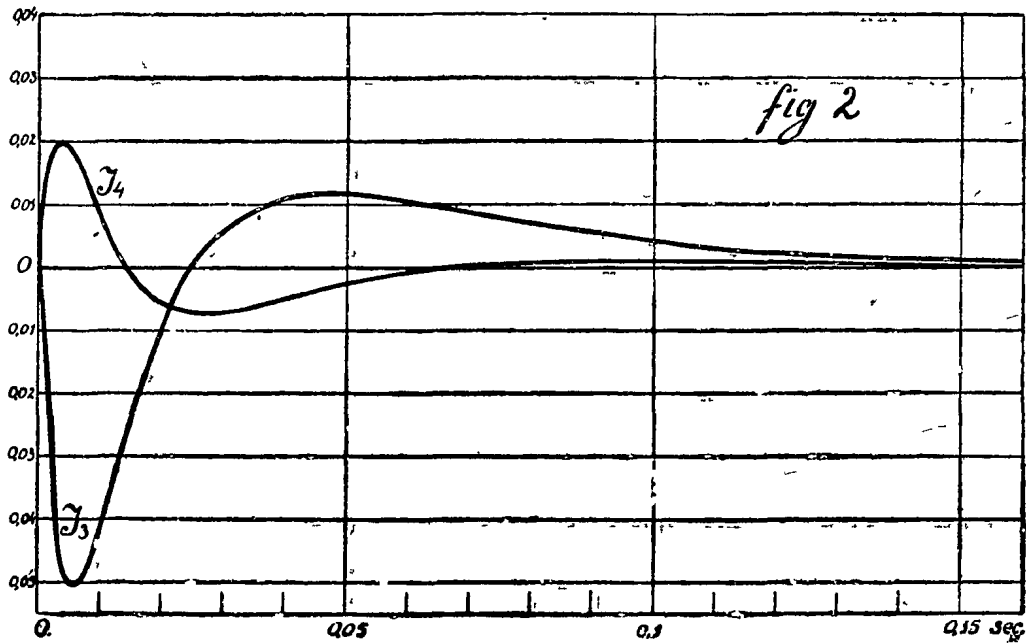

We have put

$$M = 0.03 \text{ HENRY}$$

$$L = 0.075 \text{ HENRY}$$

$$r = 4.5 \text{ OHM.}$$

The axes of abscisses give parts of a second. As ordinates we have taken the values of i , in fractions of the original intensity of

the current in the first circuit. The absolute value, when the resistance is given, depends only on the electromotive force used. Therefore it is variable within wide limits.

From fig. (1) i_1 appears to approach asymptotically to zero and therefore to get but once zero. The current $i_2 (= i_{10})$ rises from zero to a maximum value, and then falls continuously to zero again. Therefore this current twice gets the value zero. The current $i_3 (= i_9)$ (comp. fig. 2), first diminishes from zero, reaches a minimum value, rises to a maximum value and finally falls also asymptotically from the positive side to zero. It gets the zero value three times. The current $i_4 (= i_8)$ first rises in positive sense, reaches a maximum, falls through 0 to a minimum, rises again to a second maximum and finally falls asymptotically from the positive side to zero. Thus it has four roots. The current $i_5 (= i_7)$ cuts the axis one time more than i_4 , and therefore gets six times zero value.

The currents in 6 coupled circuits in a non-closed series can be represented by analogous curves, as has been remarked before.

In the exponents of all terms e^{pt} always the product rt occurs. Therefore, in changing the resistance, we can arbitrarily change the duration of the successive current-pulses. By increasing the number of coupled circuits we can arbitrarily change the number of the successive current-pulses. The magnitude of the maxima is given by the electromotive force in the first circuit, for fixed resistance, self-induction and mutual induction.

We are obliged to Prof. Dr. L. S. ORNSTEIN for his encouragement and help.

KONINKLIJKE AKADEMIE VAN WETENSCHAPPEN
TE AMSTERDAM.

PROCEEDINGS

VOLUME XIX

N^o. 2.

President: Prof. H. A. LORENTZ.

Secretary: Prof. P. ZEEMAN.

(Translated from: "Verslag van de gewone vergaderingen der Wis- en
Natuurkundige Afdeeling," Vol. XXIV and XXV).

CONTENTS.

- H. A. BROUWER: "On the tectonics of the eastern Moluccas." (Communicated by Prof. G. A. F. MOLENGRAAFF), p. 242.
- W. J. DE HAAS and Mrs. G. L. DE HAAS-LORENTZ: "An experiment of MAXWELL and AMPÈRE's molecular currents." (Communicated by Prof. H. A. LORENTZ), p. 248.
- HENDRIK DE VRIES: "The circles that cut a plane curve perpendicularly." II. p. 255.
- JAN DE VRIES: "A simply infinite system of hyperelliptical twisted curves of order five", p. 271.
- J. C. KLUYVER: "On some numerical series considered by EULER", p. 275.
- J. TRESLING: "On the use of Third Degree Terms in the Energy of a Deformed Elastic Body." (Communicated by Prof. H. A. LORENTZ), p. 281.
- J. J. VAN LAAR: "On the Fundamental Values of the Quantities b and ν/a for Different Elements, in Connection with the Periodic System III. Discussion of the Different Groups of Elements Separately." (Communicated by Prof. H. A. LORENTZ), p. 287.
- J. J. VAN LAAR: "On the Fundamental Values of the Quantities b and ν/a for Different Elements, in Connection with the Periodic System. IV. The Elements of the Halogen-Oxygen- and Nitrogen Groups." (Communicated by Prof. H. A. LORENTZ), p. 295.
- S. DE BOER: "The Structure and Overlap of the dermatomes of the hindleg with the cat." (Communicated by Prof. G. VAN RIJNBERK), p. 321.
- H. ZWAARDEMAKER: "Specific smell intensity and the electrical phenomenon of cloudlike condensed water vapours in chemical series", p. 334.
- T. P. FEENSTRA: "A new group of antagonizing atoms. II. (Communicated by Prof. H. ZWAARDEMAKER), p. 341.
- E. F. VAN DE SANDE BAKHUYZEN and J. E. DE VOS VAN STEENWIJK: "On a peculiar anomaly occurring in the transit observations with the Leiden meridiancircle during the years 1864—1868", p. 345.
- J. D. VAN DER WAALS: "The Increase of the Quantity a of the Equation of State for Densities Greater than the Critical Density", p. 359.
- W. DE SITTER: "Planetary motion and the motion of the moon according to EINSTEIN's theory", p. 367.
- F. M. JAEGER and JUL. KAHN: "Investigations on the Temperature-Coefficients of the Free Molecular Surface-Energy of Liquids between -80° and 1650° C." XV. The Determination of the Specific Gravity of molten Salts, and of the Temperature-Coefficient of their Molecular Surface-Energy, p. 381.
- F. M. JAEGER and JUL. KAHN: "Investigations on the Temperature-Coefficients of the Free Molecular Surface-Energy of Liquids between -80° and 1650° C." XVI. The surface-tension of some Halogenides of Sulphur, Phosphorus, Arsenic, Antimony and Bismuthum, p. 397.

16

Proceedings Royal Acad. Amsterdam. Vol. XIX.

- F M. JAEGER: "Investigations on the Temperature-Coefficients of the Free Molecular Surface-Energy of Liquids between -80° and 1650° C." XVII The relations between the Molecular Cohesion of Liquids at their Melting- and Boilingpoints, and their absolute Melting- and Boiling-temperatures respectively, p 405
- C M HOOGENBOOM "On the influence of an electric field on the light transmitted and dispersed by clouds." (Communicated by Prof. P. ZEEMAN), p 415
- A. SMITS and F. E. C. SCHEFFER "The Interpretation of the Rontgenograms and Rontgenspectra of Crystals." (Communicated by Prof J. D. VAN DER WAALS), p 432 (With two plates).
- H R. KRUYT and W D HELDERMAN. "The equilibrium solid-liquid-gas in binary systems which present mixed crystals." (Third communication) (Communicated by Prof. ERNST COHEN), p 439
- J DROSTE "The field of n moving centres in EINSTEIN's theory of gravitation." (Communicated by Prof. H A. LORENTZ), p 447.
- E BROUWER. "Researches on the function of the sinus venosus of the frog's heart." (Communicated by Prof H J HAMBURGER), p. 455
- C SANDERS. "Contributions towards the determination of geographical positions on the West-coast of Africa." IV (Communicated by Prof. E F VAN DE SANDE BAKHUYZEN), p. 465
- J. M. BURGERS. "Note on the model of the hydrogen-molecule of BOHR and DEBIJE" (Communicated by Prof. H A. LORENTZ), p. 480
- J. G VAN DER CORPUT. "On the values which the function $z(s)$ assumes for s positive and odd". (Communicated by Prof. J C KLUYVER). p 489

Geology. — "*On the tectonics of the eastern Moluccas*". By Dr.

H. A. BROUWER. (Communicated by Prof. G. A. F. MOLENGRAAFF).

(Communicated in the meeting of November 27, 1915).

During geological expeditions, which in the year 1915 I performed on various islands of the Moluccas¹⁾, I obtained numerous data that are important for the tectonic structure, of the country travelled over. As the very extensive material of rocks and fossils has not yet been arranged, I do not intend already to discuss these data in details. However, some results which are important for the general tectonic structure of the eastern part of the East-Indian Archipelago will be shortly indicated here.

After the geology of the Moluccas had come to be known by us as to its principal features by means of the expeditions of MARTIN, WICHMANN, BOEHM, WANNER, a.o., and principally by the Moluccas-expedition of VERBEEK, it has been chiefly both the expeditions on Timor and the surrounding islands conducted by Prof. MOLENGRAAFF of Delft, and Prof. WANNER of Bonn, that have led the way to an exact knowledge of the tectonic structure of the eastern part of our archipelago. We may consider it one of the chief provisory results of these expeditions that the structure of Timor and the adjacent islands was stated to be characterized by

¹⁾ Cf. "Voorloopige reisberichten" in the Tijdschr. v. h. Kon. Ned. Aardr. Gen. 1915 nos. 4 and 7, 1916 n^o. 1.

large overthrusts^{1) 2)}, the opinion being developed already, that these strongly folded and overthrust mountain chains surround the whole Banda-sea in the row of islands Timor—Ceram—Boeroe, and that the row of islands: Soela islands—Obi—Misool on the outside, shows no overthrust-structure³⁾.

This opinion will appear to be supported by my explorations. Also in West-New-Guinea we found in the region south of the Gulf of Mac Luer near the west coast an, — as far as is known — rather normally folded tertiary limestone-marl-series in which accidentally occur layers and nodules of hornrock, and which already HIRSCHI⁴⁾ relates to have folding-axes approximately parallel to the coastline. This points to the fact that the limit between the overthrust mountain-chains and their "Vorland" exists between both rows of islands mentioned above. This limit cannot orographically be followed, as is the case in the Alps, where e.g. the Santis "in gleich zu Stein erstarrten Wellen eines hoch brandenden Meeres die grünenden Hügel des Appenzeller Landes überragt". However, my researches enable me to determine approximately the limit between the overthrust mountain chains greatly covered by the sea, and their "vorland".

As far as the row of islands from Timor to the east has been explored during the expedition of Prof. MOLENGRAAFF, the existence of large overthrusts unto the island of Babber⁵⁾ has already been accepted; I found strongly folded mesozoic deposits on the chief island Jamdena of the Tenimber group, and for several reasons I think it rather possible that the overthrust mountain chains continue also over this group of islands. If this supposition proves to be true, the tertiary limestones of the island of Laibobar would occur on the inner side of this overthrust mesozoicum, and would e.g. be denudated in a "fenster".

The following facts seem to make this supposition probable. In

1) J. WANNER. Geologie von West-Timor. Geologische Rundschau, Bd. IV 1913, p. 145.

2) G. A. F. MOLENGRAAFF. Folded mountain chains, overthrust sheets and block-faulted mountains in the East-Indian Archipelago. Compte Rendu du XII^{me} Congrès géologique international. Toronto 1913. Ottawa 1915.

3) G. A. F. MOLENGRAAFF. Verslag betreffende de wenschelijkheid van een wetenschappelijk onderzoek van de eilandenreeks tusschen Celebes en Nieuw-Guinea enz. Tijdschr. Kon. Ned. Aardr. Gen. 1914 no. 3, blz. 369 en vlg.

4) H. HIRSCHI. Reisen in N.W. Neu-Guinea. Geogr. Ethnogr. Ges. Zürich 1907/08, p. 76.

5) F. A. H. WECKHERLIN DE MAREZ OYENS. De geologie van het eiland Babber. Handelingen van het XIV^e Nat. en Geneesk. Congres. 1913, p. 463.

West-New-Guinea, from the gulf of Mac Luer to the south, on the Kei-islands and in various islands of the Tenimber-group, tertiary, late-eocene or miocene limestone and marlformations occur, which at these different places are very similar to each other. The rocks are often bituminous, sometimes they contain bands or nodules of hornrock. Methanegases escape from these rocks at several places, e. g. near the eastcoast of Groot-Kei; and as to the little new islands near Oet (Klein Kei-group) VERBEEK ¹⁾ already supposed it to have appeared in the way of the mud-volcanoes along an anticlinal in these rocks. I found a mud-spring on the island of Mitak of the Tenimber-group, tertiary limestones and marls occurring in the vicinity on the island of Laibobar, and the supposition of the escaping methanegases originating here also in these or in deeper seated rocks is not contradicted by the facts — although rather scarce — that are hitherto known. The mesozoic rocks, which are very numerous amongst the ejections of this mud-spring, might rest upon the tertiary rocks and e. g. might have been overthrust over them. WANNER ²⁾ believes the methane-gases and the salt water of the mud-volcanoes in the whole Timor-Ceram-arch to originate in the flysch-facies of the upper-trias ³⁾.

I will not consider here how far this supposition may be deduced from the fact that the mud-springs occurring in flysch-rocks, have ejected merely pieces of flysch-rocks. In my provisory account of the geology of the island of Rotti ⁴⁾ some difficulties arising on such a supposition are indicated; and without discussing the question of the origin of the oil here in detail, I may point to the fact that the relations must be more complicated than it is supposed in the opinion mentioned above.

First of all the bituminous character of the flysch-rocks appeared to me to be a local phenomenon, which would be an indication that the origin of the oil must not be sought for in this formation. In East-Ceram numerous gas- and oil-springs are found, sometimes originating from flysch-rocks, sometimes from a limestone-marlformation, which as a rule is in many points similar to the tertiary rocks of Western New-Guinea and the Key-islands, which have been

¹⁾ R. D. M. VERBEEK. Molukken Verslag. Jaarboek v. h. Mijnwezen 1908. (Scientific part), p. 527.

²⁾ J. WANNER, l. c. p. 149.

³⁾ In connection with several facts known at the Mine office, this opinion was doubted there before I went to the Moluccas.

⁴⁾ H. A. BROUWER. Voorloopig Overzicht der geologie van het eiland Rotti Tijdschr. Kon. Ned. Aardr. Gen. 1914, blz 611.

mentioned above, so that they could be slightly different facies of rocks of about the same age.

In the valley of Wai Nief these white, grey and reddish limestones and marls, in which sometimes layers and nodules of hornrocks are found, are clearly visible on both sides of the river with a rather regular dip to the south-west. These rocks, from a provisory examination of some samples by Dr. L. RUTTEN, appeared to contain chiefly various Globigerinidae and some of them also Pulvinulina cf. tumida Brady. Although from the examination of these few samples the age of the formation could not be fixed beyond doubt, Dr. RUTTEN writes to me that the material examined seems to him to be positively of tertiary age, probably post-eocene. This formation, at the base of which oolitic limestones are found, is denudated over a surface of some square km.; it is entirely surrounded by flysch-rocks and is occasionally covered by them. In close connection with these flysch-rocks brownish-red radiolarites and basic eruptive rocks occur, this fact indicating a chaotic tectonic structure¹⁾ contrary to the rather slight folding of the tertiary rocks mentioned above. Methanegases and oil emerge from the limestones and marls, as well as from the surrounding flysch-rocks. By supposing the flysch to be overthrust over the limestones and marls, which are visible in a "fenster", we can satisfactorily account for the facts stated above. The oil and the methanegases would occur primary in the limestones and marls or in deeper-seated rocks; and even there where gas or oil emerges from flysch-rocks, their original place has not necessarily to be sought for in these rocks²⁾. The latter might be true for East-Ceram as well as for the mud spring on the isle of Mitak of the Tenimber-group.

In Western New-Guinea normally folded Tertiary, as far as is known, occurs without mesozoic cover, and the limit of the overthrust mountain chains might then, in connection with the occurrence of a "fenster" of rather slightly folded Tertiary rocks in East-Ceram, be sought to the east of this island, under the surface of the sea. On the east coast of Groot-Kei I occasionally found sandstones and iron-bearing rocks with mesozoic features, of which the tectonic relation with the tertiary limestones and marls has not yet been explained, the overthrust mountain chains might continue over the Tenimber islands and Babber to Timor.

1) J. WANNER. Triaspetrefakten der Molukken und des Timorarchipels. Neues Jahrbuch für Min. etc. Beil. Band. XXIV, p. 173.

2) In East-Ceram, at present, some boring is being done in the limestones without flysch cover, that are denudated in the valley of the W. Nief.

Over the whole length of the border of the Alps the folded miocene subalpine molasseformation dips under the chains of the Alps which are thrust over it, the molasseformation at some places still being visible as a "fenster" under the marginal chains of the Alps.

If the suppositions made above are true, the tertiary limestone and marl-formation of the Eastern Moluccas and of Western New-Guinea might well be compared with the molasse of the "vorland" of the Alps.

The western extension of the tertiary rocks of Western New-Guinea, south of the gulf of Mac Luer, must be sought for the greater part in the region between Ceram and Misool, which is covered by the sea, and to the north of it we find the islands of the row: Soela-islands—Obi—Misool, which are characterized by the large extension of jurassic rocks and where no overthrusts could be stated. Sometimes the strata are but slightly folded here. In the same facies these jurassic rocks occur at different places in Northern New-Guinea (as far as the river Tawarin at $139^{\circ} 45'$ E.L.); and it seems that the continuation of the mesozoicum of these islands has to be sought for over some of these places on New-Guinea. SUSS¹⁾ supposes the mountain-chains of Ceram also to continue over New-Guinea in the direction of the Charles-Louis mountains, and BOEHM²⁾ agrees with this opinion.

In my opinion the facts, as far as known at this time, may simply be explained by supposing that the tertiary rocks of Western New-Guinea south of the Gulf of Mac Luer are connected with the tertiary rocks of the Kei-islands, and that the mountain-chain of Ceram bends to the south. The inner zones of gneisses and micaschists of West and Mid-Ceram occur also on the island of Koer, and farther to the south, unto the island Fadoh of the Drie Gebroeders; east of these islands the strike of the normally folded tertiary rocks of West New-Guinea is bent to the south on the Key islands. The mesozoic rocks, which in East-Ceram have a great extension and are partly overthrust over tertiary rocks, similar to those of West-New-Guinea, are found only in small quantities in the region between East-Ceram and the Tenimber-islands, which for the greater part is covered by the sea.

Only the southwestern part of the island Groot-Obi and the island Gomoemoe of the Obi group, seem to belong, as for their geological

1) E. SUSS. La Face de la Terre III. 1, p. 318

2) G. BOEHM. Neues aus dem Indo Austr. Archipel. Neues Jahrbuch für Min. etc. Beil. Band XXII. 1906, p. 404.

composition, to the row Soela-islands—Obi—Misool. The northern part of Groot-Obi and the other islands of the Obi-group show a close resemblance to the northern Moluccas, as appears from the large extension of various intrusive and effusive rocks (a.o. many serpentines) and from the development of tertiary limestones, sandstones and conglomerates. A mountain-chain, in which the late-tertiary sediments often are intensively folded, continues from N.W. New-Guinea over Waigeo and Salawati up to this region.

In the northwestern part of Groot-Obi I found andesite, quite similar to many tertiary andesites of the archipelago, concordantly covered by serpentine, which points to the conclusion, that at least *part of the serpentines in the Moluccas must be of effusive origin and of relatively late, tertiary or late-mesozoic age*. This throws a new light on the distribution and age of several eruptive rocks in this part of the archipelago. If namely, serpentines are of about the same age as the younger effusive rocks — without regard to the youngest of the volcanoes — they probably have a very large extension. On the larger islands these rocks are denudated over large surfaces and the fact that the small islands wholly consist of these rocks, does not prove, that centres of volcanic action, which may be connected by volcanic fissures have existed here. They may as well be the rests of a much larger extension of these rocks in a region, which now is covered for the greater part by the sea.

For the moment we will desist from a subdivision of the various younger effusive rocks, because the material has not yet been examined microscopically. That the serpentines, at least partly, are not older than late-mesozoic, agrees with the original hypothesis of VERBEEK¹⁾, which holds various gabbros, porphyrites, melafyres, peridotites and serpentines to be probably of cretaceous age; also at other places in the Archipelago similar rocks are of cretaceous age.

In my opinion the facts, as far as they are known, seem to prove that in the eastern Moluccas the following zones occur:

1. *A zone characterized by large overthrusts*, which surrounds the Banda-sea at the inner side. Only the latest tertiary sediments did not take part in these overthrusts;
2. *A zone without overthrusts*, in which the mesozoic and tertiary sediments are sometimes folded intensively, sometimes slightly or not at all. This zone is lying outside 1 and near the contact, we find 1 thrust over 2;

¹⁾ R. D. M. VERBEEK. Voorloopig Verslag over een geologische reis door het oostelijk gedeelte van den Indischen Archipel in 1899. Extra bijv. Javasche Courant 1900, N^o. 66, p. 11.

3. *A mountain-chain farther to the north*, which can be continued from N. W. New-Guinea over Waigeo and Salawati in the eastern Moluccas and in which the late-tertiary sediments are sometimes folded intensively.

Besides folding, very numerous fractures form the principal characteristic of the tectonics of the Eastern Moluccas. Along with the many that are known, we may e.g. mention a great number on the Soela-islands, which by the occurrence of hot springs and by topographical features are often easy to trace. Also along the Sibella-mountain on Batjan numerous hot springs occur. Some fractures are volcanic fissures, however, as has been observed above, the fissures must often be later than the older volcanic rocks, so that it is not allowed to connect the places, where these rocks are found in a region that for the greater part is covered by the sea, by volcanic fissures.

Physics. — “*An experiment of MAXWELL and AMPÈRE’s molecular currents.*” By Dr. W. J. DE HAAS and Dr. G. L. DE HAAS—LORENTZ. (Communicated by Prof. H. A. LORENTZ.)

(Communicated in the meeting of June 26, 1915).

EINSTEIN and DE HAAS, who proved experimentally the existence of AMPÈRE’s molecular currents, mentioned in their paper¹⁾ that RICHARDSON has already tried, though unsuccessfully, to give a similar proof.

In connection with this it is interesting, that so early as 1861 MAXWELL.²⁾ made an experiment for the purpose of deciding whether a magnet contains any rotatory motion. This experiment was arranged as follows:

A coil can turn about a horizontal diameter BB' of a ring, which again can rotate about its vertical diameter. Let, in case the coil does not rotate, the axis CC' fixed in it coincide with the vertical one. If in the coil there are rotatory motions about an axis perpendicular to BB' and CC' and if the ring turns about its vertical diameter, the axis CC' must deviate from the vertical. Further particulars on the experiments are not known. MAXWELL mentions only that he has not been able to detect the deviation in question, even when the coil had an iron core.

¹⁾ Proc. Acad. Amsterdam. 18. p. 696.

²⁾ MAXWELL, Electricity and Magnetism, Vol. II, p. 203.

We shall now treat this problem somewhat more in detail, specializing it more than MAXWELL did. In fact we do not seek for the effect of rotatory motions of some wholly unknown kind, but for that of the circular currents supposed by AMPÈRE, or, according to the conceptions of the theory of electrons, of (negative) electrons

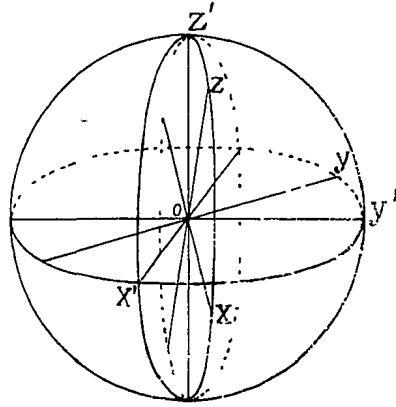

Fig. 1.

circulating round the molecules. For the sake of definiteness we shall even imagine all electrons to move with the same velocity in fixed circular paths, all of the same radius.

Fig. 1 represents this schematically.

Here OX' , OY' , OZ' are fixed axes, OZ' being vertical.

OX , OY , OZ are axes fixed in the body. We choose for these the principal axes of inertia and denote by A , B , C the moments of inertia

with respect to them. OX is the axis of the coil.

The center of gravity of the body lies in O , so that gravity does not produce a rotating couple.

Further we shall suppose the terrestrial magnetic field to be compensated.

Both systems of coordinates are of the same kind, so that they may be made to coincide by a rotation.

In the experiment the axis OY was forced to move in a horizontal plane, OX , OY , OZ can therefore be brought from the positions OX' OY' OZ' into the actual positions by means of two rotations, one about OZ' through the angle $Y'OY = \varphi$ and one about OY through the angle $Z'OZ = \theta$.

If there are no molecular currents the kinetic energy T of the body is a function of $\dot{\varphi}$ and $\dot{\theta}$, viz.

$$2T = A\dot{\varphi}^2 \sin^2 \theta + B\dot{\theta}^2 + C\dot{\varphi}^2 \cos^2 \theta \quad (1)$$

According to LAGRANGE'S equation we get for the couple tending to increase θ :

$$\Theta = \frac{d}{dt} \left(\frac{\partial T}{\partial \dot{\theta}} \right) - \frac{\partial T}{\partial \theta} = B \frac{d^2 \theta}{dt^2} + \dot{\varphi}^2 (C - A) \sin \theta \cos \theta. \quad (2)$$

Here we may remark once for all, that in this experiment the axis OY rotates with constant velocity in a horizontal plane about OZ' , so that $\dot{\varphi}$ is a constant. In order that without an external couple Θ a stable state may be possible in which OZ and OZ' coincide, so

that $\theta = 0$, C must be greater than A . Then the body can perform a vibration consisting in periodical changes of the angle θ , and for infinitely small amplitudes we find the frequency :

$$n = \dot{\varphi} \sqrt{\frac{C-A}{B}} \dots \dots \dots (3)$$

If there are circulating electrons we shall have to introduce new parameters in addition to the angles φ and θ . For these parameters we choose the angles ψ , measured from a fixed point in the path of each electron towards its momentary position.

The kinetic energy will now contain a part corresponding to (1) which depends on $\dot{\theta}$ and $\dot{\varphi}$ and which we shall call T_1 . But besides it will contain two parts T_2 and T_3 , to which we shall soon refer.

As to T_1 , it is the question, whether when there are moving electrons, the moments of inertia A , B , C will perhaps depend on ψ , so that they are no longer constants.

For the sake of simplicity we suppose the iron core to be magnetized to saturation, so that all the molecular axes are directed along the axis of the coil, while the circular currents are perpendicular to this line. We neglect the heat motion which would prevent this perfect orientation.

To calculate the moment of inertia with respect to one of the axes OX , OY , OZ for an electron, moving in a circle with the center M , we draw through M a line parallel to the axis considered. The moment of inertia with respect to this line can easily be calculated and from it we deduce the required moment of inertia by a well known rule. It is evident, that the part contributed to A by the circulating electrons will not depend on the positions in their paths, but will have a constant value.

On the contrary, the part contributed by one circulating electron to B and C (i. e. to the moments of inertia with respect to the axes in the plane of the circle) will change continually. But as soon as there are in each circle more than two electrons, at fixed distances from each other (so that one angle ψ determines the positions of them all) the terms in B and C due to them will have constant value. This is easily seen. Let n electrons circulate in the path. Their moment of inertia with respect to a diameter of the circle is proportional to

$$\begin{aligned} & \sin^2 \psi + \sin^2 \left(\psi + \frac{2\pi}{n} \right) + \sin^2 \left(\psi + \frac{4\pi}{n} \right) \dots \dots = \\ & = \frac{1}{2} \left\{ n - \cos 2\psi - \cos 2 \left(\psi + \frac{2\pi}{n} \right) - \cos 2 \left(\psi + \frac{4\pi}{n} \right) - \dots \dots \right\} \end{aligned}$$

and the value of this is $\frac{1}{2}n$ as soon as $n > 2$. Indeed, the points on the circle, determined by the angles 2ψ , $2\left(\psi + \frac{2\pi}{n}\right)$, $2\left(\psi + \frac{4\pi}{n}\right)$, and so on, are the vertices of a regular polygon and therefore the resultant of the vectors drawn from the center towards these points is zero. Thus the moments of inertia A , B , C will not depend on ψ . Though they will be increased to a certain extent by the presence of circulating electrons, we may continue to represent them by A , B , C . No ambiguity will arise from this.

The second part T_2 of the kinetic energy depends on ψ . It is evident, that one electron gives

$$\frac{1}{2} m r^2 \dot{\psi}^2,$$

if m is its mass and r the radius of its path. As we suppose $\dot{\psi}$, m and r to be the same for all the electrons, we may write

$$2T_2 = D \dot{\psi}^2.$$

where

$$D = \Sigma m r^2,$$

the summation being extended to all the circulating electrons.

The third part T_3 will depend on the products $\dot{\varphi}\dot{\psi}$, $\dot{\theta}\dot{\psi}$. It is the existence of this part, that MAXWELL wanted to test experimentally.

The calculation of T_3 requires somewhat more consideration. A material point with mass m and two velocities v_1 and v_2 (vectors) has the kinetic energy.

$$\frac{1}{2} m v_1^2 + \frac{1}{2} m v_2^2 + m (v_1 \cdot v_2) \dots \dots \dots (4)$$

We shall apply this to each circulating electron. It will possess firstly the velocity v_2 due to its motion in the circle and secondly the velocity v_1 due to the motion of the whole body. Now the first two parts of (4) are contained in T_1 and T_2 . The velocity v_1 may be resolved into the velocities due to the rotations of the body about OX , OY , OZ , and each of these rotations may be replaced by a translation and a rotation about a parallel axis through the center M of the path of the electron. Let us call the velocities of the electron belonging to these rotations v_{1a} , v_{1b} , v_{1c} . It is clear that the two latter components are perpendicular to v_2 , so that they do not contribute anything to the scalar product $(v_1 \cdot v_2)$. The same may be said of the component of the translatory velocity perpendicular to the plane of that circle. As to the translatory velocity in this plane, it may contribute a term to $(v_1 \cdot v_2)$ in the case of one electron, but it is easily found that these contributions compensate each other, when n electrons are moving in the same circle, the reason

being that the velocities v_2 of all these particles have the same value but different directions which succeed each other at equal angular intervals. The only component that contributes a part to the scalar product, is v_{1a} , which always has the same direction as v_2 . As the component of the angular velocity about the axis through M parallel to OX is equal to $-\dot{\varphi} \sin \theta$, we find for $m(v_1 \cdot v_2)$

$$-mr\dot{\psi} \cdot r\dot{\varphi} \sin \theta.$$

Taking the sum for all the circulating electrons, we find

$$-\dot{\psi}\dot{\varphi} \sin \theta \cdot \Sigma mr^2 = -D \dot{\psi}\dot{\varphi} \sin \theta.$$

Thus the whole kinetic energy becomes

$$T = \frac{1}{2} \{A \dot{\varphi}^2 \sin^2 \theta + B \dot{\theta}^2 + C \dot{\varphi}^2 \cos^2 \theta + D \dot{\psi}^2 - 2 D \dot{\psi} \dot{\varphi} \sin \theta\}$$

Writing $A + D$ for A , we get

$$T = \frac{1}{2} \{A \dot{\varphi}^2 \sin^2 \theta + B \dot{\theta}^2 + C \dot{\varphi}^2 \cos^2 \theta + D (\dot{\psi} - \dot{\varphi} \sin \theta)^2\},$$

So that the force tending to increase ψ is given by

$$\Psi = \frac{d}{dt} \left(\frac{\partial T}{\partial \dot{\psi}} \right) - \frac{\partial T}{\partial \psi} = \frac{d}{dt} \{D (\dot{\psi} - \dot{\varphi} \sin \theta)\}$$

We shall start from the supposition that there are no forces acting on the electrons, by which their velocities in their paths might be changed. We then have

$$\Psi = 0, \text{ or } \dot{\psi} - \dot{\varphi} \sin \theta = \text{const.} = \gamma \quad \dots \quad (5)$$

and we find instead of (2)

$$\Theta = B \frac{d^2 \theta}{dt^2} + (C - A) \dot{\varphi}^2 \sin \theta \cos \theta + D \dot{\varphi} \gamma \cos \theta \quad \dots \quad (5a)$$

We have seen already, that C must be greater than A .

In the stationary state, in which θ does not change, $\frac{d^2 \theta}{dt^2}$ will be equal to zero; so that in the absence of a couple Θ , the angle θ will assume a constant value given by

$$\sin \theta = - \frac{D}{C-A} \frac{\gamma}{\dot{\varphi}}.$$

The same formula may be found in a somewhat simpler way by considering the moments of momentum. We then must apply the following principle. In any system the change of the resultant moment of momentum has the direction of the moment of the couple that gives rise to this change.

In our case the only couple acting on the system arises from the forces applied at the extremities of the axis OY , by which this axis is compelled to move in a horizontal plane with the constant angular velocity φ . The axis of this couple lies in the plane XOZ . Independ-

dently of the magnetization the body possesses moments of momentum about its axes OX and OZ . In addition to these it has a magnetic moment of momentum about OZ . So at all events the total moment of momentum will fall along a certain line OL in the plane $Z'OX$. If now this resultant OL did not coincide with OZ' , it would continually change its direction because of its rotation about OZ' . The corresponding change in the moment of momentum would be perpendicular to the plane $Z'OL$ and this ought also to be the direction of the couple acting on the body. We have seen, however, that this axis lies in the plane $Z'OX$. Hence OL and OZ' must coincide.

The condition for this is, that the moment of momentum about OX , divided by that about OZ must be equal to $-tg \theta$. Thus we have

$$\frac{D \dot{\psi} - \dot{\varphi} \sin \theta}{C \dot{\varphi} \cos \theta} = -tg \theta$$

or, writing again $A + D$ for A ,

$$\frac{D (\dot{\psi} - \dot{\varphi} \sin \theta) - A \dot{\varphi} \sin \theta}{C \dot{\varphi} \cos \theta} = -tg \theta,$$

from which we infer

$$\sin \theta = - \frac{D}{C-A} \cdot \frac{\dot{\psi} - \dot{\varphi} \sin \theta}{\dot{\varphi}}$$

or if we introduce the value for $\dot{\psi} - \dot{\varphi} \sin \theta$, given by (5)

$$\sin \theta = - \frac{D}{C-A} \cdot \frac{\gamma}{\dot{\varphi}} \dots \dots \dots (6)$$

To investigate, whether the experiment will give a perceptible value of θ , it is desirable to express $\sin \theta$ in quantities that can easily be estimated. As D and $\dot{\psi}$ are unknown, we shall introduce instead of them the magnetization I of the body.

If O is the area of a circular current, its magnetic moment in the case of only one electron circulating in it, is

$$e O \frac{\dot{\psi}}{2\pi} = \frac{1}{2} e \dot{\psi} r^2;$$

If we take the sum for all the circulating electrons this expression becomes

$$I = \Sigma \frac{1}{2} e \dot{\psi} r^2 = \frac{e}{2m} \dot{\psi} \Sigma m r^2 = \frac{e}{2m} \dot{\psi} D.$$

Hence

$$D\dot{\varphi} = \frac{2m}{e} I$$

I is the magnetization which the body would have in the case $\dot{\varphi} = 0$ and $\theta = 0$. We may safely assume, that this value scarcely differs from the magnetization that would exist when θ and $\dot{\varphi}$ were different from zero. Thus

$$D\gamma = \frac{2m}{e} I.$$

Substituting this in (6), we find

$$\sin \theta = -\frac{2m}{e} I \frac{1}{C-A} \cdot \frac{1}{\dot{\varphi}} \dots \dots (7)$$

According to this formula it would be possible to reach an infinite value of $\sin \theta$ by making C and A equal to each other. It is true that a strong magnetization can only be obtained by using a rather long rod of iron, but notwithstanding this the difference $C-A$ may be made as small as we like by adjusting non-magnetizable masses in a proper way. In reality however this ideal case can never be realised. The principal reason for this is, that the point of suspension will never coincide with the centre of gravity, but will always be at a small distance say q from the latter.

In this case, contrary to what we have supposed, the force of gravity will produce a couple acting on the body. Taking $C-A=0$ and writing P for the weight of the body we now get instead of (5a)

$$-Pq \sin \theta = B \frac{d^2 \theta}{dt^2} + D\dot{\varphi} \gamma \cos \theta \dots \dots (5b)$$

so that the condition for the stationary state becomes

$$\operatorname{tg} \theta = -\frac{\dot{\varphi}}{Pq} D\gamma$$

Introducing

$$D\gamma = \frac{2m}{e} I$$

and the time of oscillation t for vibrations about OY under influence of gravity, a time that is given by

$$t^2 = 4\pi^2 \frac{B}{Pq},$$

we find finally

$$\operatorname{tg} \theta = -\frac{2m}{e} I \cdot \frac{t^2 \dot{\varphi}}{4\pi^2 B}.$$

We shall make an estimate of the value of θ by means of the following values, which have all been chosen very favourably. Density of magnetisation 1.000

$$I = 150, \dot{\varphi} = 100, t^2 = 10, B = 1, \frac{2m}{e} = 1,1 \cdot 10^{-7}.$$

We then find

$$\operatorname{tg} \theta = -0,00013,$$

from which we may conclude, that the deviation will be hardly perceptible.

Mathematics. — “*The circles that cut a plane curve perpendicularly*”.

II. By Prof. HENDRIK DE VRIES.

(Communicated in the meeting of February 26, 1916).

§ 7. We found in the preceding § that through the point Z_∞ pass three different kinds of branches of the rest nodal curve, and in particular the branches of the first kind arose in groups of 4 at a time. If $S_{1\infty}$, $S_{2\infty}$ are two simple points of intersection of k'' with l_∞ , then the lines of connection of these points with Z_∞ are double torsal lines of Ω (§ 2), and the 4 sheets passing through these torsal lines cut each other in 4 branches of the rest nodal curve, which of course all pass through Z_∞ , and have only *one* tangent here, viz. the line of intersection of the two tangent planes along the torsal lines, i.e. the line of connection of Z_∞ with the intersection of the asymptotes of k'' in $S_{1\infty}$ and $S_{2\infty}$.

The branches of this first kind behave again differently according to their going towards the foci and the vertices, or to other points of k'' ; the branches going to the foci and the vertices are their own images with regard to β , those to other points, as the nodes, the cusps, the intersections of the isotropical tangents, are each other's images. This difference has an influence on the nature of the tangents in Z_∞ ; for a branch that is its own image Z_∞ must be a point of inflexion, as on a straight line passing through this point and cutting the curve twice, the two points of intersection approach to Z_∞ from different sides; two branches on the contrary that are each other's images and pass through Z_∞ , simply have the same tangent in this point. But whichever of the two cases may arise the projection of 4 branches belonging together produces a node in the intersection of the associated asymptotes of k'' . If namely a twisted curve is projected out of one of its points of inflection, the projection possesses

a cusp in the intersection of the inflectional tangent; if therefore the curve is symmetrical with regard to β , and Z_∞ a point of inflection, the projection consists of a branch ending in the intersection of the asymptotes in $S_{1\infty}$ and $S_{2\infty}$, and which is described to and fro. This arises, however, 4 times, and the 4 branches ending thus in one and the same point run together into a curve with a node, for which the discontinuity is again cancelled. And if we have to do with branches which are each other's images and for which Z_∞ is consequently an ordinary point, these branches project themselves in pairs in one and the same branch, which passes, however, through the intersection of the asymptotes of k'' , and in this way a node also arises in that case. So we have for all cases the following proposition: *the locus of the points out of which two equally long tangents may be drawn at k'' has nodes in the $\frac{1}{2}(\mu-2\varepsilon-2\sigma)(\mu-2\varepsilon-2\sigma-1)$ intersections of the asymptotes of k'' .*

For the general conic this phenomenon arises once; in fact the locus in question consists here of the two axes, and therefore has a node in the centre; the 4 branches passing through Z_∞ go to the foci here.

If two asymptotes of k'' are chosen arbitrarily, and a hyperbola is constructed, which has these two lines for asymptotes, and e.g. in order to arrive at the greatest possible contact with k'' , this curve is osculated in one of the two points at infinity in question, the difference between the tangents at the hyperbola and at the curve becomes practically imperceptible for some point or other in the immediate neighbourhood of the intersection of the asymptotes; from which we may conclude that our locus of points of equal tangents at k'' passes the intersection of the two asymptotes in the same directions as the axes of the hyperbola, viz. in the directions of the bisectrices of the angles of the asymptotes. We may therefore complete the above found property of our curve by adding that *the two nodal tangents in an intersection of two asymptotes of k'' bisect the angles of those asymptotes.*

The branches of the 2nd kind passing through Z_∞ arise from the points of contact of k'' and l_∞ , and appear in groups of 8 at a time (cf. § 6); they are in pairs each other's images with regard to β , or, if we subject Ω to a projective transformation, they are associated in pairs to each other in the involutory collineation of which Z_∞ is the centre, and β is the plane.

The 8 branches passing through Z_∞ have therefore in this point only 4 tangents (entirely lying in ε_∞), and the intersections of these tangents (lying on l_∞) are simple points of the locus of the points

of equal tangents at k'' . The total number of these points amounts to $2\sigma(\sigma-1)$, and to the same two points of contact $R_{1\infty}$, $R_{2\infty}$ of k'' and l_∞ belong 4 of those points. If they are considered as centres of circles twice cutting k'' perpendicularly, the circle itself always coincides with l_∞ , and though l_∞ does not cut k'' in $R_{1\infty}$, $R_{2\infty}$, but touches it, there can be no objection, for the line l_∞ encloses with itself any arbitrary angle. Even planimetrically it is clear that to two points of contact with l_∞ belong 4 simple infinite branches of the locus of equal tangents; if we viz. imagine 2 parabolic branches of k'' , out of one point or another go 2 tangents at each of them, so that for the equality of 2 of those tangents, touching at different branches, there are 4 possibilities; in this way 4 simple infinite branches of the curve arise.

The branches of the 3rd kind finally arise from the combination of a simple intersection S_∞ of k'' and l_∞ with a point of contact R_∞ (§ 6); they arise in groups of 4, are associated to each other in pairs in the involutory collineation $Z_\infty\beta$, and have all 4 only one tangent in Z_∞ , viz. apparently the line $Z_\infty S_\infty$ itself; the consequence of this is that through S_∞ pass 2 branches of the locus of equal tangents, that is to say 2 branches for each point R_∞ , consequently 2σ together. So: the $\mu-2\varepsilon-2\sigma$ simple intersections of k'' and l_∞ are for the locus of the points of equal tangents 2σ -fold points.

This result as well allows of being verified planimetrically.

Let us imagine a hyperbolic and a parabolic branch of k'' , out of a point of β near the asymptote passes then one tangent lying very close to that asymptote, while two tangents touch at the parabolic branch; so there are 2 possibilities for the equality of those tangents, and consequently 2 branches of the locus of the points of equal tangents go in the direction of the asymptote towards infinity. Even, as $Z_\infty S_\infty$ is a torsal line of Ω the plane of osculation in Z_∞ will coincide with the torsal plane, and consequently the tangent in S_∞ at each branch of the locus of the points of equal tangents with the asymptote of k'' . We may therefore add to the preceding: all branches of the locus of the points of equal tangents passing through a point S_∞ of k'' , have in this point the asymptote of k'' as a tangent.

§ 8. In § 6 we have determined the number of intersections that an arbitrary plane passing through Z_∞ has apart from Z_∞ in common with the rest nodal curve of Ω , and we have determined from it the order d^k of the locus of the points of equal tangents at k'' ; for the plane ε_∞ , however, the calculation is somewhat different, as several branches passing through Z_∞ touch the plane ε_∞ . The branches

of the first kind (§ 6) cut ε_∞ in Z_∞ ; the number of intersections, arising from them, amounts therefore to:

$$2(\mu - 2\varepsilon - 2\sigma)(\mu - 2\varepsilon - 2\sigma - 1).$$

The $4\sigma(\sigma - 1)$ branches of the second kind, and the $4\sigma(\mu - 2\varepsilon - 2\sigma)$ of the third touch ε_∞ on the contrary in Z_∞ and so give respectively $8\sigma(\sigma - 1)$ and $8\sigma(\mu - 2\varepsilon - 2\sigma)$ -intersections; the sum total of these three numbers is: $2\mu^2 - 8\mu\varepsilon - 2\mu + 8\varepsilon^2 + 4\varepsilon - 4\sigma$.

If this number is subtracted from the order of the rest nodal curve as given in § 6, the number of points ε_∞ has in common with the rest nodal curve apart from Z_∞ is found; this number amounts to

$$\varrho = 4\mu\nu - 4\mu\sigma - 8\nu\varepsilon + 8\varepsilon\sigma - 13\nu + 8\varepsilon + 9\sigma + 5\mu + \nu^2 + \sigma^2 - 2\nu\sigma + 3\varepsilon.$$

These points lie in pairs harmonically with regard to Z_∞ and β , either on k_∞^2 or on the generatrices of Ω lying in ε_∞ and passing through Z_∞ ; their projections on l_∞ are points at infinity of the locus of the points of equal tangents at k^ν . To these points at infinity however belong also the projections of those points lying infinitely near to Z_∞ , and which we have already determined in the preceding §, viz. $2\sigma(\sigma - 1)$ simple, and $(\mu - 2\varepsilon - 2\sigma)$ 2σ -fold ones (the latter lying in the simple intersections of k^ν and l_∞). If these numbers are doubled, are then added to the given number ϱ mentioned above, and the result is divided by 2, the order d' of § 6 is exactly found back.

If a branch of the rest nodal curve of Ω gets into k_∞^2 , and if we let a point P describe that branch, and that in the direction towards k_∞^2 , the image circle of P , which twice cuts k^ν perpendicularly gets greater and greater; if P moves along a hyperbolic branch, that circle will have as limit a straight line containing the intersection of the asymptote with β , and this straight line will twice cut k^ν perpendicularly, and consequently be a *double normal*. If, however, P moves along a parabolic branch, the circle will in the end disappear into infinity. In this way the number of double normals of k^ν is therefore not to be determined; this, however, is not necessary, as we already determined this number pretty nearly in our former paper. (*Ann. Cykl.* p. 21). The double normals of k^ν are namely apparently double tangents of the evolute of k^ν , and for the number of these double tangents we found *ibid.*:

$$\frac{1}{2}\{(\mu + \nu - 2\varepsilon - \sigma)(\mu + \nu - 2\varepsilon - \sigma - 1) - (\nu + 3\mu)\}.$$

In this number l_∞ , however, is comprised a number of times. The evolute namely has cusps in each of the $\mu - 2\varepsilon - 2\sigma$ simple intersections of k^ν with l_∞ , and that in such a way that the cuspidal tangent coincides with l_∞ , and in each of the σ points of

contact of l'' and l_∞ it has points of inflection, while the inflectional tangent coincides with l_∞ again; it is therefore clear that in l_∞ a certain number of double tangents coincide. This number is easy to determine. Let us first imagine 2 of the σ points of inflection and let us observe that in each point of inflection 3 points of the curve lie on a straight line, then it is clear that a double inflectional tangent absorbs 4 double tangents; l_∞ is, however, inflectional tangent for σ points of inflection, consequently it absorbs $\frac{1}{2} \sigma(\sigma-1)$. 4 double tangents on account of this.

Further is l_∞ $(\mu-2\varepsilon-2\sigma)$ -times cuspidal tangent; as such it contains therefore $\frac{1}{2}(\mu-2\varepsilon-2\sigma)(\mu-2\varepsilon-2\sigma-1)$ further double tangents; and finally each cusp may be combined with each point of inflection, which produces 2 double tangents every time, in consequence of the 3 points which lie infinitely near to each other in the point of inflection; to the two preceding numbers $2\sigma(\mu-2\varepsilon-2\sigma)$ must still be added. If the sum of these three numbers is subtracted from the number given higher up, we find for the number of double normals of l'' :

$$\frac{1}{2}(2\mu v - 2\mu\sigma - 3\mu + v^2 - 4v\varepsilon - 2v\sigma - v + 4\varepsilon\sigma + \sigma^2 + 3\sigma - \varepsilon).$$

To each of these two points of l_∞^2 harmonical with regard to Z_∞ and β are associated, and if we now subtract the double number of double normals from the number of points that ε_∞ outside Z_∞ has in common with the rest nodal curve, as was given at the beginning of this §, we find that

$$2\mu v - 2\mu\sigma - 4v\varepsilon + 4\varepsilon\sigma - 12v + 8\varepsilon + 6 + 8\mu + 4\varepsilon$$

remain.

Now we know already from the example of the parabola (§ 5) that points of this kind exist in fact; there we found 2, viz. the two points at infinity of the nodal curve of Ω , and the number arrived at here really gives 2 for the parabola. These points lie on the line connecting Z_∞ with the point of contact of the parabola and l_∞ , and form a necessary completion of a few numbers found in § 7; where we namely in § 7 considered tangents of equal length at *different* parabolical branches or at parabolical and hyperbolical branches, there we have of course also to consider tangents of equal length at one and the same parabolical branch, and this we find here now; the total number of these points amounts to 2σ , so that the remaining ones indicate parabolical branches of the rest nodal curve.

§ 9. The order of the rest nodal curve of Ω may moreover be

17*

determined in quite another way than was done in § 6, viz. by making use of the first polar surface of Z_∞ . This surface, of which the order is one unit lower than the one of Ω , and therefore (cf. § 2) amounts to $2\mu + 2\nu - 4\varepsilon - 2\sigma - 1$, produces in the first place the "contour apparent" of Ω , seen from point Z_∞ ; but it is easy to see that there can hardly be question of a real "contour apparent". If namely a straight line passing through Z_∞ touches Ω (in a point outside β we will suppose), consequently intersects it in two points lying infinitely near to each other, it must be possible to describe round the foot of that perpendicular two circles cutting k^ν perpendicularly whose rays only differ infinitely little, and this is not impossible, for it holds good for all the points of the inflectional tangents of Ω , but then exclusively for them. We found in fact before that the generatrices passing through the points of inflection of k^ν were torsal lines of Ω with vertical tangent planes; these torsal lines, to the number of 2ι , belong therefore to the intersection of Ω with the first polar surface of Z_∞ , and in reality form the only "contour" of Ω for Z_∞ , barring of course k^ν itself, which, as a matter of course and as is clear from the simple example of the hyperboloid of revolution, also belongs to the "contour apparent."

Let us imagine a line passing through Z_∞ drawn to a point P of k^ν . We know that along k^ν 2 sheets of Ω osculate each other, and now ask how many points the line $Z_\infty P$ in P has in common with Ω . This number will amount to 4, just as when the sheets simply touched each other along k^ν , for otherwise the two branches would possess points of inflection in P in an intersection with a plane passing through $Z_\infty P$, which is not the case. Besides, round the foot of an arbitrary line passing through Z_∞ ν circles are to be described cutting k^ν perpendicularly, and round P $\nu - 2$; 4 points of Ω have consequently coincided on $Z_\infty P$ in P . Of the first polar surface have therefore on $Z_\infty P$ 3 points coincided in P , and the question is now what is the shape of that polar surface, as it can only touch the two sheets of Ω passing through k^ν . The fact is that the first polar surface breaks up into a surface and the plane ρ , and consequently has k^ν as a nodal curve. A line $Z_\infty P$ now contains the point P of the nodal curve, and moreover a neighbouring point, and therefore 3 indeed.

That β is a part of the first polar surface of Z_∞ ensues already from the symmetry of Ω with regard to β . An arbitrary straight line passing through Z_∞ cuts Ω only in 2ν points not coinciding with Z_∞ , and consequently in $2\mu - 4\varepsilon - 2\sigma$ points that do

coincide with Z_∞ , the first polar surface therefore cuts that straight line as well in $2\mu - 4\varepsilon - 2\sigma$ points coinciding with Z_∞ , and further in the $2\nu - 1$ harmonic poles of Z_∞ with regard to the 2ν points of Ω not coinciding with Z_∞ . Now the first polar surface of Z_∞ must of course be symmetrical with regard to β , as Ω is so too; but the number $2\nu - 1$ is odd, while of these points not one can lie in infinity; consequently *one* must lie in β , and this holds good for any straight line passing through Z_∞ .

Analytically too it is easy to see. The 2ν points referred to higher up may be represented by an equation of the form.

$$(z^2 - a^2)(z^2 - b^2)(z^2 - c^2) \dots = 0,$$

and the harmonical centres for the pole Z_∞ are found from it by differentiation with regard to z ; it appears then at once that each term contains the factor z .

The first polar surface of Z_∞ consequently breaks up into the plane β and a surface π_1 , which only reaches the order $2\mu + 2\nu - 4\varepsilon - 2\sigma - 2$, and only contains k^ν as a simple curve. By the way we will observe that Ω contains still other torsal lines with vertical tangent planes, viz. the tangents out of the two absolute circle-points at k^ν (§ 2), and that these lines therefore also belong to the intersection of Ω with the first polar surface; as they lie, however, in β , and are only to be counted once, they do not lie on π_1 .

The intersection of Ω with π_1 now consists of the following parts:

1. The curve k^ν . We saw already that π_1 touches the two sheets of Ω passing through k^ν in k^ν itself, but those two sheets osculate each other, that is to say, in each intersection with a plane passing through Z_∞ they have not 2 but 3 points in common; π_1 must also pass through this third point, that is to say, osculates each of those two sheets, and consequently has the curve k^ν six times in common with Ω .

2. The curve l_∞^2 . It is for Ω $(\nu - \sigma)$ -fold (§ 2), consequently for π_1 $(\nu - \sigma - 1)$ -fold; in the intersection of Ω and π_1 this conic counts therefore $(\nu - \sigma)(\nu - \sigma - 1)$ times.

3. The $\mu - 2\varepsilon - 2\sigma$ double torsal lines of Ω arising from the simple intersections of k^ν with l_∞ ; these lines show for π_1 the same character as for Ω , that is to say, through each of these lines, which are to be considered twice as torsal lines, pass 2 sheets of Ω and 2 of π_1 , so that such a line counts 8 times in the intersection.

4. The σ double torsal lines of Ω , arising from the points of contact of k^ν with l_∞ ; for them the same holds good as for those of the preceding group, each of these σ lines therefore counts 8 times in the intersection.

5. The 2κ cuspidal edges of Ω , the 45° -lines passing through the cusps of k'' (§ 3). The cuspidal tangent planes of these cuspidal edges always pass through Z_∞ , so that a line $Z_\infty P$ connecting Z_∞ with a point P of such a cuspidal edge has in P with Ω 3, and consequently with π_1 2 points in common. It is, however, easy to see that in the intersection of Ω with π_1 , each cuspidal edge is to be counted 4 times, and this is only to be brought into conformity with the rest if we accept that a cuspidal edge of Ω is a nodal edge of π_1 .

That this must be so in fact is most easily seen in the example of the plane cubic with cusp. It is of class 3, and the polar conic of an arbitrary pole P passes through the cusp, touches at the cuspidal tangent here and consequently has 3 points in common here with the curve, the remaining 3 intersections are the points of contact of the 3 tangents out of \mathcal{P} . If, however, P lies on the cuspidal tangent there touch at the curve but 2 tangents besides this one, the polar conic of P must therefore have now in the cusp 4 points in common with the curve, but the cuspidal tangent has in the cusp only 3 points in common with the curve, and consequently only 2 points in common with the polar conic. These various conditions are only satisfied at the same time if the polar conic degenerates into a pair of lines whose node lies in the cusp. By applying this argument to the cuspidal edges of Ω we easily find that they are nodal edges of π_1 , and consequently count 4 times in the intersection with Ω , and as through each cusp of k'' pass two of those cuspidal edges, the share contributed by all those cuspidal edges to the intersection is of order 8κ .

6. The 2ι torsal lines of Ω passing through the points of inflection of k'' (vide supra).

7. The rest nodal curve. It lies on π_1 as a simple curve, and consequently is counted twice in the intersection. The calculation of order d of the nodal curve in this way is as follows. The surfaces Ω and π_1 are respectively of the orders $2\mu+2\nu-4\epsilon-2\sigma$ and $2\mu+2\nu-4\epsilon-2\sigma-2$, the order of their complete intersection is therefore the product of these two numbers. In order to find $2d$ now this product is to be diminished by 6μ , $2(v-\sigma)(v-\sigma-1)$, $8(\mu-2\epsilon-2\sigma)$, 8σ , 8κ , 2ι .

§ 10. The second polar surface of Z_∞ with regard to Ω , which we shall call π_2 , is of order $2\mu+2\nu-4\epsilon-2\sigma-2$, consequently as Ω of even order, and therefore need not break up as the former. In fact, if we represent the intersections of a line passing through Z_∞

with the complete 1st polar surface by:

$$z(z^2 - a^2)(z^2 - b^2) \dots = 0$$

it appears at once by means of differentiation that $z = 0$ satisfies no more. π_2 contains the curve k'' , for the latter is a nodal curve for the complete first polar surface, as we saw in the preceding §. It further follows from the symmetry with regard to β that the tangent planes at π_2 are vertical in all the points of k'' , while this is also to be deduced from the fact that a straight line $Z_\infty P$, connecting Z_∞ with a point P of k'' , touches the surface π_1 in P , and so has here 3 points in common with the complete first polar surface $\pi_1 + \beta$.

This observation is important to us as we want to intersect π_2 with the rest nodal curve of Ω , all the points of the rest nodal curve namely that are lying in β and at the same time on k'' will as a matter of course belong to those intersections. But also the intersections of the rest nodal curve and β not lying on k'' , viz. the foci of k'' , lie on π_2 . The first polar surface $\pi_1 + \beta$ namely must contain the complete nodal curve, π_1 therefore contains the rest nodal curve, consequently also the foci of k'' , and the vertical lines passing through these points have in those points three points in common with $\pi_1 + \beta$ and consequently two points with π_2 . So we state that π_2 and the rest nodal curve have in common. 1. $2(\mu - 2\varepsilon - \sigma)^2$ points, lying in the foci of k'' ; 2^o) $2(5\mu - 3\nu + 3\varepsilon - 8\varepsilon - 3\sigma)$ points lying in the vertices of k'' .

The rest nodal curve intersects β further in the $2(\mu - \varepsilon - 2)(\nu - 2\varepsilon - \sigma)$ points P , which the tangents out of the two isotropical points have moreover in common with k'' (cf § 6); through each of these points pass 2 branches of the rest nodal curve, which both touch at the same vertical line, and 3 sheets of Ω , which touch at the line $Z_\infty P$ as well; from the latter we deduce that $Z_\infty P$ has in P in common with Ω 6 points, consequently with $\pi_1 + \beta$ 5 points and with π_2 4 points. If we now move the line $Z_\infty P$ a little, and do so parallel to itself, those 4 coinciding points diverge and arrange themselves into 2 pairs which are each other's image with regard to β ; from this it ensues that through P pass 2 sheets of π_2 , which both touch at $Z_\infty P$ in P . Each branch of the rest nodal curve touches at those two sheets and consequently has with them together 4 coinciding points in common; the two branches consequently 8 points, from which it ensues that *the rest nodal curve and π_2 3^o) have in common $16(\mu - \varepsilon - 2)(\nu - 2\varepsilon - \sigma)$ points, lying in the intersections of the tangents out of the isotropical points at k'' with k'' .*

Let us consider a node D of k'' . According to § 6 there pass

through this point 4 branches of the rest nodal curve, and 4 sheets of Ω , which all touch at the line $Z_\infty D$ in D ; $Z_\infty D$ has therefore in D with Ω 8 points in common, consequently 6 points with π_2 , and by applying again, as above, the proceeding of the parallel shifting, we find that through D 3 sheets of π_2 pass, which all touch at the line $Z_\infty D$. Each of the 4 branches of the rest nodal curve which pass through D , touches at each of these 3 sheets; this procures in total 24 coinciding points, so that we can say: *the rest nodal curve and π_2 have 4^o) 24 points in common, lying in the nodes of k'' .*

Let us consider a cusp K of k'' . Through an arbitrary point of k'' pass 2 tangents less than through a point that does not lie on k'' , and as with each tangent 2 generatrices of Ω correspond, the vertical passing through an arbitrary point of k'' has 4 coinciding points in common with Ω , and passing through a node 8 (vide supra). Through a cusp pass three tangents less than through an arbitrary point of the plane; therefore the vertical $Z_\infty K$ has in K 6 points in common with Ω , and consequently 4 points with π_2 . Through K pass 2 cuspidal edges of Ω , and we know (cf. § 9) that they are nodal edges for π_1 and consequently simple edges for π_2 . Let us therefore imagine a vertical in the neighbourhood of $Z_\infty K$, cutting the two cuspidal edges, the latter has then on those cuspidal edges already 2 points in common with π_2 , and consequently quite close to them 2 more other points, which are each other's image with regard to β . From this we infer that through K too, pass 3 sheets of π_2 , viz 2 through the two cuspidal edges and still a third formed by those two other points and touching at the line $Z_\infty K$, because it must have 4 points in common with π_2 ; and as through K pass 6 branches of the rest nodal curve and that without vertical tangents, there lie in K 18 intersections of the rest nodal curve and π_2 , united. Consequently *the rest nodal curve and π_2 have 5^o) 18 points in common, lying in the cusps of k'' .*

With this the intersections of the rest nodal curve and π_2 , as far as they lie in β , have been summed up.

The rest nodal curve and π_2 have also points at infinity in common. In the first place Z_∞ has as a point of π_2 the same character as as a point of π_1 , and as a point of Ω , so that all the points of the rest nodal curve, of which we calculated in § 8 that they lay in Z_∞ or infinitely near to it, also belong to π_2 . This number amounted to (§ 8) $2\mu^2 - 8\mu\varepsilon - 2\mu + 8\varepsilon^2 + 4\varepsilon - 4\sigma$, and this would therefore be the number that we have in view here, if π_2 , as ε_∞ , had a simple point in Z_∞ . This, however, is by no means the case, as we observed

just now, and the consequence of it is that a far greater number of intersections of the rest nodal curve and π_2 have coincided in Z_∞ than we mentioned just now.

We have to go back to the 3 different kinds of branches of the rest nodal curve passing through Z_∞ , which we summed up in § 6. The branches of the first kind, arising from the sheets of Ω passing through the $\mu - 2\varepsilon - 2\sigma$ double generatrices going to the intersections S_∞ of k' and l_∞ , appear in groups of 4 and touch in Z_∞ at the straight lines going to the intersections of the asymptotes of k' ; such a branch touches at the 4 sheets of π_2 passing through the same double generatrices as the sheets of Ω that produce the group of 4, and has therefore in consequence of this already 8 points in common with π_2 . It further cuts the $2(\mu - 2\varepsilon - 2\sigma - 2)$ remaining sheets of π_2 of the same kind one by one simply and also the 2σ sheets of π_2 passing through the σ double generatrices of Ω that go to the points of contact R_∞ of k' and l_∞ , so that it has totally in Z_∞ $8 + 2(\mu - 2\varepsilon - 2\sigma - 2) + 2\sigma$ points in common with π_2 . The group now consists of 4 of those branches and the number of groups amounts to $\frac{1}{2}(\mu - 2\varepsilon - 2\sigma)(\mu - 2\varepsilon - 2\sigma - 1)$, we find therefore a number of points:

$$a = 4 \{8 + 2(\mu - 2\varepsilon - 2\sigma - 2) + 2\sigma\} \cdot \frac{1}{2}(\mu - 2\varepsilon - 2\sigma)(\mu - 2\varepsilon - 2\sigma - 1).$$

The second group arose from the sheets of Ω passing through the lines $Z_\infty R_\infty$, which sheets all touch at ε_∞ , the branches meant here appear in groups of 8. One branch out of such a group touches at all the 2σ sheets of π_2 passing through the lines $Z_\infty R_\infty$ and has alone from this source therefore already 4σ points in common with π_2 . It cuts on the contrary the $2(\mu - 2\varepsilon - 2\sigma)$ sheets of π_2 passing through the lines $Z_\infty S_\infty$, and the number of groups amounts to $\frac{1}{2}\sigma(\sigma - 1)$; as a second contribution to the number looked for by us we find therefore:

$$b = 8 \{4\sigma + 2(\mu - 2\varepsilon - 2\sigma)\} \cdot \frac{1}{2}\sigma(\sigma - 1).$$

Finally we have the branches of the 3rd group procured by the intersection of the sheets of Ω passing through the $\mu - 2\varepsilon - 2\sigma$ straight lines $Z_\infty S_\infty$ and the σ straight lines $Z_\infty R_\infty$; these branches appear in groups of 4, and all touch at ε_∞ . Such a branch now touches in the first place at the 2σ sheets of π_2 passing through the lines $Z_\infty R_\infty$, which therefore produces 4σ points, touches then moreover at the 2 sheets of π_2 passing through the line $Z_\infty S_\infty$, which so to say belongs to the group, which procures 4 further points, and cuts the $2(\mu - 2\varepsilon - 2\sigma - 1)$ sheets of π_2 passing through the remaining lines $Z_\infty S_\infty$; the number of groups is moreover $(\mu - 2\varepsilon - 2\sigma)\sigma$, so that the third and last contribution to the numbers wanted is:

$$c = 4\{4\sigma + 4 + 2(\mu - 2\varepsilon - 2\sigma - 1)\}(\mu - 2\varepsilon - 2\sigma)\sigma.$$

The number of intersections of the rest nodal curve with π_2 coinciding in Z_∞ is therefore represented by the sum of the numbers a , b and c . At infinity there lie, however, other intersections yet, viz. among others on l_∞^2 . This conic is for Ω a $(v-\sigma)$ -fold one and consequently for π_2 a $(v-\sigma-2)$ -fold curve, and contains according to § 8 $\varrho-2\sigma$ simple points of the rest nodal curve; the total amount of intersections on l_∞^2 amounts therefore to $(\varrho-2\sigma)(v-\sigma-2)$.

As to the 2σ points that are withdrawn from ϱ they lie (cf. the example of the parabola in § 5) on the straight lines $Z_\infty R_\infty$, and are intersections of the rest nodal curve with ε_∞ . As, however, two sheets of π_2 pass through each line $Z_\infty R_\infty$, the number of intersections from this source becomes 4σ .

§ 11. We have now calculated how many intersections the rest nodal curve and π_2 have in β , and how many they have in ε_∞ , if there are more yet, they lie consequently neither in β nor in ε_∞ , and it is the nature of these points we really want to find out. As the rest nodal curve lies both on Ω and π_1 , an intersection of the rest nodal curve and π_2 lies on Ω , π_1 , and π_2 , and from this it ensues that the line connecting this point with Z_∞ has in this point 3 coinciding points in common with Ω . This may in general happen as one of the 2 principal tangents of that point passes through Z_∞ , but such a thing is excluded for the surface Ω as we saw; if namely a vertical line should contain 3 infinitely near points of Ω , 3 circles cutting l'' perpendicularly might be drawn whose rays differ infinitely little, and this would only be possible if l'' possessed a tangent having contact in 4 points, which we have not supposed. Another possibility remains now, viz. that the points in question are triple points of Ω . Such a point arises when 3 different generatrices of Ω pass through the same point; it is in that case a triple point for the rest nodal curve, and its cyclographic image-circle will therefore cut l'' thrice perpendicularly.

There is, however, a third possibility yet, and this is concerned with cuspidal edges of Ω . Through each cusp of l'' pass two cuspidal edges of Ω , and according to § 9 each suchlike cuspidal edge is a nodal edge of π_1 , and consequently also a simple straight line of π_2 , while the 3rd polar surface does not contain it any more and so cuts in a certain number of points. Let us consider such an intersection P . This point lies on Ω and on the 1st, 2nd and 3rd polar surface, from which it ensues that the line $Z_\infty P$ has in P 4 coinciding points in common with Ω . Now has $Z_\infty P$ in P 3 points

in common with Ω , if P is an arbitrary point of the cuspidal edge, a 4th point can therefore only arise as the cuspidal edge is cut by an ordinary generatrix of Ω , the number of these points we find therefore by cutting the cuspidal edge with the 3rd polar surface. This third polar surface now is of order $2\mu + 2\nu - 4\varepsilon - 2\sigma - 3$, and as this order is odd, the surface will have to contain again this plane β with a view to the symmetry with regard to β ; what remains is of order $2\mu + 2\nu - 4\varepsilon - 2\sigma - 4$, and will be called π_3 . Of the intersections of this surface π_3 with the cuspidal edge, one more point, however, lies in β , viz. in the cusp K , so that only $2\mu + 2\nu - 4\varepsilon - 2\sigma - 5$ remain that do not lie in β . According to the preceding § the line $Z_\infty K$ has namely in K 4 points in common with π_3 , consequently 3 with $\pi_3 + \beta$, of these one belongs to β , so that 2 remain for π_3 , and with a view to the symmetry of π_3 with regard to β , they can only lie on a tangent of π_3 , π_3 therefore passes through K with one sheet. *Each cuspidal edge of Ω is therefore cut by $2\mu + 2\nu - 4\varepsilon - 2\sigma - 5$ ordinary generatrices, and these points are cusps of the rest nodal curve, while their image circles cut k'' twice perpendicularly, of which once in the associated cusp.*

The latter is a matter of course, that, however, the points in question are cusps of the rest nodal curve follows at once from the consideration of the generatrices of Ω , which lie close to the one that cuts the cuspidal edge; they form namely with each other a certain sheet of Ω , and this of course cuts the two sheets meeting in the cuspidal edge in a cusp, the cuspidal tangent lies then in the cuspidal tangent plane of Ω , that is to say in the vertical plane passing through the cuspidal edge. *In the projection we find therefore for the locus of the points of equal tangents at k'' a cusp, lying on a cuspidal tangent; and the number of these points on one and the same cuspidal tangent of k'' amounts to $2\mu + 2\nu - 4\varepsilon - 2\sigma - 5$.*

We saw above that in a cusp P of the rest nodal curve, lying on a cuspidal edge of Ω , the line $Z_\infty P$ has 4 points in common with Ω , and consequently with π_3 , which also contains the cuspidal edge, 2; the tangent plane in P at π_3 passes therefore through the cuspidal edge and is vertical. The cuspidal tangent in P lies now, according to the above mentioned fact, in this vertical plane, from which it ensues that the nodal curve and π_3 have 3 coinciding points in common in each point P .

The complete number of intersections of the rest nodal curve and π_3 amounts to $(2\mu + 2\nu - 4\varepsilon - 2\sigma - 2)d$; if we now put apart from this all the groups of points summed up in this and the preceding §, the triple points of the rest nodal curve remain, or, more clearly

stated, a number of points remain which must of necessity coincide in groups of 3. If we therefore call this number x , the number of triple points of the rest nodal curve is $\frac{1}{3}x$. These points lie in pairs symmetrical with regard to β , the number of points in β therefore, which are centres of circles that cut k^v thrice perpendicularly, is $\frac{1}{6}x$, and these points are triple points for the locus of the points of equal tangents.

We find the following formula for v :

$$x = (2\mu + 2\nu - 4\varepsilon - 2\sigma - 2)d - 2(v - 2\varepsilon - \sigma)^2 - 2(5\mu - 3\nu + 3\varepsilon - 8\varepsilon - 3\sigma) - 16(\mu - \varepsilon - 2)(\nu - 2\varepsilon - \sigma) - 24d - 18\kappa - a - b - c - 4\sigma - (q - 2\sigma)(\nu - \sigma - 2) - 6\kappa(2\mu + 2\nu - 4\varepsilon - 2\sigma - 5).$$

It is of course possible to express x exclusively in the fundamental characters chosen by us, viz. $\mu, \nu, \varepsilon, \sigma, \iota$; the formula in that case, however, becomes very intricate, so we prefer to leave it in the form given here, a form which is not more circumstantial for the calculation, and has the advantage that of the parts that must be subtracted, the meaning is easily recognized.

If it is applied either to the general conic or the parabola, it gives $x = 0$, which is correct, as with the conic no circles can appear that cut the curve thrice perpendicularly; for the c_3^3 the calculation is as follows; $\mu = \nu = 3, \varepsilon = \sigma = 0, \iota = 0, \kappa = 1, \iota = 1; a = 120, b = c = 0; d = 36, q = 24$, consequently $x = 10.36 - 18 - 18 - 18 - 48 - 120 - 24 - 42 = 72$; there are therefore 12 points that are centres of circles that cut c_3^3 thrice perpendicularly and are therefore triple points of the locus of equal tangents at k^v ; this locus has moreover 7 cusps on the cuspidal tangent of k^v , and with that line itself as tangent; they are the centres of the circles that cut c_3^3 perpendicularly in the cusp and moreover somewhere else. For c_4^3 we have: $\mu = 3, \nu = 4, \varepsilon = \sigma = 0, \iota = 3, \sigma = 1, \kappa = 0, d = 48, a = 120, b = c = 0, q = 36$, and so:

$$x = 12.48 - 32 - 24 - 64 - 24 - 120 - 72 = 240;$$

the locus of the points of equal tangents has therefore 40 triple points.

To wind up this § we will now sum up what we have found of the locus of the points of equal tangents at k^v .

This curve is of order d^ (§ 6); in each node of k^v it has 2 cusps, while through each cusp of k^v pass 3 branches, which all touch at the cuspidal tangent. Further it passes through each vertex and through each focus of k^v and it possesses nodes in the intersections of the asymptotes of k^v , while the nodal tangents bisect the asymptotal angles. Its points at infinity are: 1. $2\sigma(\sigma - 1)$ simple points (§ 7), 2. $\mu - 2\varepsilon - 2\sigma$ 2σ -fold points lying in the intersections of k^v with l_∞ ,*

while here all the branches have the asymptotes of k'' as tangents (§ 7); 3. $\frac{1}{2} \rho - \sigma$ simple points (§ 8); 4 σ simple points lying in the points of contact of k'' and l_∞ . And finally it possesses $\frac{1}{6} x$ triple points, and on each cuspidal tangent of k'' $2\mu + 2\nu - 4\varepsilon - 2\sigma - 5$ cusps whose tangents all coincide with the cuspidal tangent.

§ 12. As, by the preceding investigations, the cyclographic surface Ω has been completely inquired into, we must be able now to give an answer to any questions that may arise concerning the circles that cut k'' perpendicularly. Let us therefore in the first place inquire after the curve that arises if we measure off on each tangent of k'' from the point of contact a piece of prescribed length on either side; it is clear that we have simply to cut Ω with a plane that runs parallel with β , and that we have to project the intersection on β . We find therefore a curve of order $2(\mu + \nu - 2\varepsilon - \sigma)$, which has nodes anywhere where it meets the rest nodal curve, and cusps where it meets the cuspidal edges of Ω . It further passes $(\nu - \sigma)$ times through the absolute points of β , while it passes with 2 branches, which each have the asymptote of k'' as an asymptote, through each of the $\mu - 2\varepsilon - 2\sigma$ simple intersections of k'' and l_∞ , and likewise passes with 2 branches through each of the σ points of contact of k'' and l_∞ , while those two branches touch here at k'' as well.

For the ellipse we find in that way a curve of order 8, consisting of two completely separated and closed ovals. The curve does not possess cusps, but does possess 8 nodes, 4 on the major axis and 4 on the minor one. Of the 4 on the major axis 2 are real nodes, and they of course lie outside the ellipse, while the two others are isolated and lie between the foci; of the 4 on the minor axis 2 are likewise real nodes, and they of course lie again outside the ellipse, while the two others are imaginary in this case. Real points at infinity the curve does not possess at all, they appear with the hyperbola where every time 2 branches also have as asymptotes the asymptotes of the hyperbola. For this, however, the nodes in one axis viz. the non-intersecting one, become all 4 imaginary, while in the character of the 4 on the other axis no change arises; the 2 nodes lie now only between the vertices, and the two isolated nodes outside the foci.

For the parabola the curve is of order 6; it possesses 2 real nodes, both lying on the axis of the parabola; one, a real node, lies outside the parabola, the other, an isolated node, between the focus and the point at infinity, moreover 2 parabolical branches touch at l_∞ in the point at infinity of the parabola. Further are, in the case

of the parabola, the circle points, simple points, in the case of the two other conics, nodes.

If the plane of intersection is placed in an oblique position so that it gets an intersection d in common with β , the circles are found that cut k'' perpendicularly and d under an angle of constant cosine, which cosine may very well be > 1 (viz. if the angle of the plane with β is $< 45^\circ$), if the angle is exactly 45° the circles cutting k'' perpendicularly and touching at d are found.

The circles cutting k'' perpendicularly and passing through a given point P of β (which point may or may not lie on k'') are found by cutting the surface Ω with the equilateral cone of revolution with vertical axis, whose vertex lies in P ; the circles touching at a given circle by cutting Ω with one of the two equilateral cones of revolution with vertical axis which have the given circle as base-circle; on the other hand we find the circles that cut, besides k'' , also an arbitrarily given circle perpendicularly. by cutting Ω with the equilateral hyperboloid of revolution for which that circle is the throat circle.

But instead of the simple figures, point, straight line, and circle, a second arbitrary curve k' may be considered, of order μ' , etc. and we may inquire after the circles cutting both these curves perpendicularly at a time, especially *one* twice, the other *once*; it is clear that the answer to any questions that may be put here will be obtained by cutting the surfaces Ω and Ω' with each other. And if one goes a step farther in this direction and combines the surfaces Ω , Ω' , Ω'' , all the circles that cut 3 given curves at a time perpendicularly are found.

Finally, the cyclographic surfaces, belonging to touching circles and perpendicularly cutting circles may be combined together, and so e.g. investigate the circles that cut *one* of two given curves perpendicularly and touch the other, with the peculiarities consequent on this, as e.g. the circles of curvature, or the twice touching circles of *one* curve, which cut the other perpendicularly, or the circles that cut *one* curve twice perpendicularly and touch at the other, etc., and if one imagines only *one* curve as given, but for this one constructs both the surface belonging to the touching circles and the one belonging to perpendicularly cutting circles, one finds by their intersection the circles that touch a given curve and cut it perpendicularly at a time, with all the peculiarities that may arise here, and without other difficulties having to be overcome with it but those comprised in the tracing of the unreal, and therefore to be separated, solutions.

Mathematics. — “A simply infinite system of hyperelliptical twisted curves of order five.” By Prof. JAN DE VRIES.

(Communicated in the meeting of March 25, 1916).

§ 1. By the equations

$$\frac{\alpha a^2_x + \beta b^2_x}{c^2_x} = \frac{\alpha a'_x + \beta b'_x}{c'_x} = \frac{\alpha a''_x + \beta b''_x}{c''_x} \dots \dots (1)$$

a simply infinite system of twisted curves is determined, which are each the partial intersection of a cubic and a quadratic surface. For, if, for the sake of brevity, the equations (1) are replaced by

$$\frac{d^2_x}{c^2_x} = \frac{d'_x}{c'_x} = \frac{d''_x}{c''_x} \dots \dots (2)$$

it appears that the surfaces $d^2_x c'_x = c^2_x d'_x$ and $d'_x c''_x = c'_x d''_x$ have in common the straight line t , which is represented by $c'_x = 0$, $c''_x = 0$. A plane passing through t intersects the two surfaces moreover along a conic and a straight line; from this it ensues that t is a trisecant of the twisted curve Q^5 which is determined by the surfaces mentioned.

As (2) may be replaced by

$$\frac{d^2_x}{c^2_x} = \frac{d'_x + \lambda d''_x}{c'_x + \lambda c''_x} = \frac{d''_x}{c''_x} \dots \dots (3)$$

the trisecants of Q^5 may be represented by

$$d'_x + \lambda d''_x = 0, \quad c'_x + \lambda c''_x = 0 \dots \dots (4)$$

They form one of the systems of generatrices on the hyperboloid $d'_x c'_x = c'_x d''_x$; the second system of generatrices consists of bisecants of Q^5 .

The trisecants of the curves Q^5 determined by (1) are therefore indicated by

$$\alpha a'_x + \beta b'_x + \lambda (\alpha a''_x + \beta b''_x) = 0 \quad c'_x + \lambda c''_x = 0 \dots (5)$$

They lie on the hyperboloids of the pencil

$$\alpha (a'_x c''_x - a''_x c'_x) + \beta (b'_x c''_x - b''_x c'_x) = 0 \dots \dots (6)$$

The base of this pencil consists of the straight line c , represented by $c'_x = 0$, $c''_x = 0$, and a cubic γ^3 , of which c is a chord; γ^3 is indicated by

$$\begin{vmatrix} a'_x & b'_x & c'_x \\ a''_x & b''_x & c''_x \end{vmatrix} = 0 \dots \dots (7)$$

All the trisecants t intersect the straight line c and the base-curve γ^3 ; they form therefore the congruence (1,3), which has c and γ^3 as directrices.

Through each point of γ^3 passes a plane pencil of trisecants; this appears moreover from (5): the plane pencil in the plane (λ) has as vertex the intersection of the planes $a'_1 + \lambda a''_1 = 0$, $b'_1 + \lambda b''_1 = 0$, $c'_1 + \lambda c''_1 = 0$.

§ 2. As the system (1) may be replaced by the system

$$\left. \begin{aligned} \alpha a^2_x + \beta b^2_x + \gamma c^2_x &= 0 \\ \alpha a'_x + \beta b'_x + \gamma c'_x &= 0 \\ \alpha a''_x + \beta b''_x + \gamma c''_x &= 0, \end{aligned} \right\} \dots \dots \dots (8)$$

all the curves q^5 lie on the *quartic surface* Φ^4 , represented by

$$\begin{vmatrix} a^2_x & b^2_x & c^2_x \\ a'_x & b'_x & c'_x \\ a''_x & b''_x & c''_x \end{vmatrix} = 0 \dots \dots \dots (9)$$

Through a point of Φ^4 passes, in general, *one* curve q^5 ; we shall therefore call the system (q^5) a *pencil*.

An arbitrary straight line is therefore cut by *four* curves q^5 . On Φ^4 lies also the curve γ^3 , any trisecant t intersects Φ^4 on γ^3 and in the three points, in which it meets the corresponding curve q^5 .

All the q^5 pass through the points C_1 and C_2 indicated by $c_1^2 = 0$, $c'_1 = 0$, $c''_1 = 0$. These points are therefore *singular points* of (q^5).

From (1) it appears that the surface Φ^4 may be produced by combining the pencil

$$\alpha (a_1 c''_2 - c'_2 a''_1) + \beta (b_1 c''_2 - c'_2 b''_1) = 0 \dots \dots \dots (6)$$

with one of the pencils

$$\left. \begin{aligned} \alpha (a^2_x c'_x - c^2_x a'_1) + \beta (b^2_x c'_x - c^2_x b'_1) &= 0, \\ \alpha (a^2_x c''_x - c^2_x a''_1) + \beta (b^2_x c''_x - c^2_x b''_1) &= 0 \end{aligned} \right\} \dots \dots \dots (10)$$

As product of two projective pencils we find then besides Φ^4 the plane $c'_2 = 0$ or the plane $c''_2 = 0$.

In connection with this we consider the curve φ^4 , in which Φ^4 is intersected by the arbitrary plane φ , as product of a cubic pencil with a quadratic pencil. The first, (φ^3) , has two base-points F_1, F_2 on the intersection f of φ with $c'_2 = 0$ and seven base-points F_k ($k = 3$ to 9) on φ^4 . The second pencil, (φ^2) , has a base-point G_1 on f , the remaining three, G_k ($k = 2, 3, 4$) on φ^4 . The projectivity has been arranged in such a way that two homologous curves intersect in a point Q of f .

The two pencils determine on φ^4 the same involution I^5 ; each group Q_x ($k = 1$ to 5) consists of the intersections of φ with one of the curves q^5 .

We shall now determine the class of the curve enveloped by the straight line $Q_k Q_l$; it is at the same time the order of the line-complex formed by the bisecants of the curves q^5 .

To this purpose we make use of the following general proposition¹⁾. If a curve q^n is intersected by a pencil (q') in the groups of an involution I^s , the lines connecting the pairs envelop a curve of class $\frac{1}{2}(n-1)(2s-n)$.

From this it appears that *the bisecants of the curves q^5 form a complex of order nine.*

§ 3. We arrive at the same result by paying attention to the pairs of lines of the pencil (ρ^2) . The straight line $G_2 G_3$ determines by its intersection Q with f , a q^3 , which meets the straight line $G_1 G_4$ in three points of a curve q^5 , hence $G_1 G_4$ is a trisecant t . In the same way $G_1 G_2$ and $G_1 G_3$ appear to be trisecants. These three straight lines evidently replace nine bisecants. No bisecant can belong to the plane pencil (G, ρ) as it would have to lie then on a pair of lines of (ρ^2) . From this it ensues that the *complex* of the bisecants is of order *nine*.

In a plane passing through the straight line c , lies, as appeared above, a *plane pencil of trisecants*. As all the q^5 pass through the points C_1, C_2 , any ray passing through one of these points, is bisecant for three different curves q^5 , which are indicated by the intersections of that ray with Φ^4 . In any plane passing through c the complex curve degenerates therefore into *three plane pencils*, which must each be counted thrice.

The *complex cone* of an arbitrary point P has *three triple edges*. One of them is the ray, which the congruence (1,3) of the trisecants sends through P , the other two connect P with the *cardinal points* C_1, C_2 .

For a point of the straight line c the complex cone is replaced by the *rational cubic cone*, which projects the curve γ^3 , this cone consists completely of *trisecants* and is therefore to be counted thrice.

If P is taken on Φ^4 , the complex cone degenerates into the *cone of order four \mathfrak{K}^4* , which projects the curve q^5 indicated by P , consequently has a *nodal edge*, and a *cone of order five \mathfrak{K}^5* , which is the locus of the sets of four bisecants which the curves q^5 send through P .

¹⁾ Cf. my paper "Quadruple involutions on biquadratic curves". (Proceedings and Communications of the Royal Ac. of Sc. section Physics, series III, volume 4, p. 312 French translation in Archives Neerlandaises, Vol. 23, page 93).

If P lies on the curve γ^3 , \mathfrak{K} degenerates moreover into the *plane pencil of the trisecants*, lying in the plane (Pc) and a *quadratic cone* \mathfrak{K}^2 .

This cone contains the bisecants belonging to the second system of generatrices of the hyperboloids (6). For they are indicated (cf. § 1) by

$$aa'_x + \beta b'_x + \gamma c'_x = 0 \quad , \quad aa''_x + \beta b''_x + \gamma c''_x = 0,$$

they are therefore the bisecants of the curve γ^3 , which according to (7) is determined by

$$\begin{vmatrix} a'_x & b'_x & c'_x \\ a''_x & b''_x & c''_x \end{vmatrix} = 0.$$

The edges of \mathfrak{K}^2 therefore project γ^3 out of P as centre.

§ 4. An involution I^s , which is produced by the intersection of a pencil of curves on a curve of genus g , has $2(g + s - 1)$ groups with a double point¹⁾. In an arbitrary plane lie therefore 14 touching bisecants; in other words the *tangents* r of the curves φ^5 form a *congruence of class fourteen*.

If the plane φ passes through c , ten of those tangents belong to the plane pencil of trisecants lying in it; they are the tangents at φ^4 from the vertex of the plane pencil. The tangents in C_1 and C_2 at φ^4 are therefore to be counted *twice*.

In order to be able to determine the order of the congruence $[r]$, we consider the twisted curve containing the ends Q, Q' of the chords lying on the complex cone of a point P . As this cone is of order 9, the order of the curve in question amounts to 18; this φ^{18} has evidently *nodes* in the ends of the triple chord, lying on that cone (§ 3) and triple points in C_1 and C_2 .

The planes connecting Q and Q' with the arbitrary straight line l agree in an involutorial correspondence (18, 18), of which the plane (Pl) represents an 18-fold coincidence. The remaining 18 arise from pairs $Q' \equiv Q$, consequently from tangents r ; hence the order of $[r]$ is *eighteen*.

The points C_1 and C_2 are *singular points of order one*.

¹⁾ Ibid. p. 322.

Mathematics. — “*On some numerical series considered by EULER.*”

By Professor KLUYVER.

(Communicated in the meeting of April 28, 1916.)

In Nov. Comment. Petrop. XX, 1775. page 140, EULER wrote a paper entitled: “*Meditationes circa singulare serierum genus.*” He treated in it certain numerical series of the form

$$\varphi(\alpha, \beta) = \sum_{n=1}^{n=\infty} \frac{1}{n^\alpha} \left\{ \frac{1}{1^\beta} + \frac{1}{2^\beta} + \frac{1}{3^\beta} + \dots + \frac{1}{n^\beta} \right\},$$

in which α and β are positive integers, and his aim was to prove that the series $\varphi(\alpha, \beta)$, which he denoted by $\int \frac{1}{z^\alpha} \left(\frac{1}{y^\beta} \right)$, might be expressed integrally and rationally for all values of α and β by the values which $\zeta(s)$ assumes for positive integer values of s .

Writing $\alpha + \beta = M$, EULER indicates, how by a peculiar and ingenious calculation a system of equations may be deduced, which involve the quantities $\varphi(k, M-k)$ for $k = 2, 3, 4, \dots, M-1$ as unknown quantities, so that everything is reduced to the solution of this system of equations. He considers in this way the cases $M = 3, 4, \dots, 15$ and tries, by means of a bold induction, to arrive at a general solution of the problem from those special cases. He does not completely succeed in this. It appears from his investigations that the cases M even and M odd are quite different. For M odd the equations considered by him may be solved, for M even, however, they are dependent on each other, and his efforts to express $\varphi(\alpha, \beta)$ in this case by ζ -values miscarry. It still remains an open question whether for M even in general, such an expression in any way can be found. In what follows a direct evaluation of $\varphi(\alpha, \beta)$ is given for M odd, while I shall further shortly consider the results at which EULER arrived for the case M even.

It may be observed beforehand that $\varphi(k, M-k)$ and $\varphi(M-k, k)$ for $1 < k < M-1$ are connected in a simple way.

We evidently have viz.

$$\varphi(k, M-k) + \varphi(M-k, k) = \zeta(k) \zeta(M-k) + \zeta(M)$$

and in particular

$$\varphi(N, N) = \frac{1}{2} \zeta(N)^2 + \frac{1}{2} \zeta(2N),$$

so that for given M only $\frac{M-1}{2}$ quantities at most, are to be calculated.

I start from certain pretty simple trigonometrical series determined by the equations

$$g_{2k}(t) = \frac{2(-1)^{k+1}}{(2\pi)^{2k}} \sum_{n=1}^{\infty} \frac{\cos 2\pi nt}{n^{2k}} \quad g_{2l+1}(t) = \frac{2(-1)^{k+1}}{(2\pi)^{2k+1}} \sum_{n=1}^{\infty} \frac{\sin 2\pi nt}{n^{2k+1}}$$

These series, satisfying the relation

$$g^{m+1}(t) = g_m(t),$$

represent, with the exception of $g_1(t)$, continuous periodic functions of t .

If $0 < t < 1$ is, they are equal to simple polynomials in t , which are in fact the derivatives of the polynomials of BERNULLI. Otherwise stated, for $0 < t < 1$ the functions $g_m(t)$ are determined as coefficients of expansion; we have

$$\frac{xe^{xt}}{e^x-1} = 1 + \sum_{m=1}^{\infty} g_m(t)x^m,$$

and from this it ensues, always supposing $0 < t < 1$,

$$g_1(t) = t - \frac{1}{2}, \quad g_2(t) = \frac{t^2}{2!} - \frac{1}{2}t + \frac{B_2}{2!}, \quad g_3(t) = \frac{t^3}{3!} - \frac{1}{2} \cdot \frac{t^2}{2!} + \frac{B_1}{2!}t \text{ etc.}$$

It is to be seen that every polynomial in t is to be expressed in g -functions for $0 < t < 1$. This holds true in particular for the product of two g -functions and such a product is reduced in the following way.

From the identical equation

$$\begin{aligned} \frac{xe^{tx}}{e^x-1} \cdot \frac{ye^{ty}}{e^y-1} &= \frac{xy}{x+y} \cdot \frac{(x+y)e^{t(x+y)}}{e^{x+y}-1} \cdot \frac{e^{x+y}-1}{(e^x-1)(e^y-1)} \\ &= \frac{(x+y)e^{t(x+y)}}{e^{x+y}-1} \cdot \frac{xy}{x+y} \left\{ \frac{1}{e^x-1} + \frac{1}{e^y-1} + 1 \right\} \end{aligned}$$

follows

$$\begin{aligned} \left\{ 1 + \sum_{h=1}^{\infty} g_h(t)x^h \right\} \left\{ 1 + \sum_{k=1}^{\infty} g_k(t)y^k \right\} &= \\ = \left\{ 1 + \sum_{m=1}^{\infty} g_m(t)(x+y)^m \right\} \left\{ 1 + \sum_{n=1}^{\infty} g_{2n}(0)xy \cdot \frac{x^{2n-1} + y^{2n-1}}{x+y} \right\}. \end{aligned}$$

If on both sides of this equation the coefficient of $x^h y^k$ is taken the product $g_h(t)g_k(t)$ will be found expressed linearly by g -functions by equating the results.

In this way we obtain

$$\begin{aligned} g_h(t)g_k(t) &= (h+k)_h g_{h+k}(t) + \{(h+k-3)_{h-1} + (h+k-3)_{k-1}\} g_{h+k-2}(t)g_2(0) \\ &\quad + \{(h+k-5)_{h-1} + (h+k-5)_{k-1}\} g_{h+k-4}(t)g_4(0) \\ &\quad + \{(h+k-7)_{h-1} + (h+k-7)_{k-1}\} g_{h+k-6}(t)g_6(0) \\ &\quad \dots \dots \dots \end{aligned}$$

If $h+k$ is odd the last term on the second side may contain $g_1(t)$, if, however, $h+k$ is even, half of the last term must be taken and the latter will therefore be

$$\frac{1}{2} \{ (-1)^{h-1} + (-1)^{k-1} \} g_0(t) g_{h+k}(0) = (-1)^{h-1} g_{h+k}(0)$$

According to the deduction, this formula holds only true for $0 < t < 1$ but it is to be seen that for all real values of t it is still correct. If h and k differ both from 1, the coefficient of $g_1(t)$ on the right hand side will be equal to zero. Both sides of the equation are therefore continuous functions, with the period 1, which functions must coincide everywhere because they are equal to each other in the interval $(0,1)$.

We arrive at the same conclusion, if h and k are both equal to 1, and should we have $h=1$, k unequal to 1, the continuity for k odd remains on both sides, while for k even the two sides show quite the same discontinuity for $t=0$ and for $t=1$. In this case too we conclude to the equality of the two sides for all real values of t , and the equation has therefore general validity.

This equation now gives the means to calculate $\varphi(\alpha, \beta)$ directly, if $\alpha + \beta = M$ is odd.

Let α be odd, β even, then we have

$$\int_0^{\infty} \frac{g_{\alpha}(t) g_{\beta}(t)}{t} dt = \frac{4(-1)^{\frac{M-1}{2}}}{(2\pi)^M} \int_0^{\infty} \frac{dt}{t} \sum_{n=1}^{\infty} \frac{\sin 2\pi nt}{n^{\alpha}} \cdot \sum_{m=1}^{\infty} \frac{\cos 2\pi mt}{m^{\beta}}$$

For $\alpha > 1$ the integrand is continuous, integration by terms of the product of the two series is allowed, and the following result is in this way found for the integral:

$$\begin{aligned} \frac{4(-1)^{\frac{M-1}{2}}}{(2\pi)^M} \cdot \frac{\pi}{2} \sum_{n=1}^{\infty} \frac{1}{n^{\alpha}} \left\{ \frac{1}{1^{\beta}} + \frac{1}{2^{\beta}} + \dots + \frac{1}{(n-1)^{\beta}} + \frac{1}{n^{\beta}} \right\} = \\ = \frac{4(-1)^{\frac{M-1}{2}}}{(2\pi)^M} \cdot \frac{\pi}{2} \left\{ \varphi(\alpha, \beta) - \frac{1}{2} \zeta(M) \right\}. \end{aligned}$$

In exactly the same way we find

$$\begin{aligned} \int_0^{\infty} \frac{g_{M-2\nu}(t) g_2(0)}{t} dt = \frac{4(-1)^{\frac{M-1}{2}}}{(2\pi)^M} \zeta(2\nu) \int_0^{\infty} \frac{dt}{t} \sum_{n=1}^{\infty} \frac{\sin 2\pi nt}{n^{M-2\nu}} = \\ = \frac{4(-1)^{\frac{M-1}{2}}}{(2\pi)^M} \cdot \frac{\pi}{2} \zeta(M-2\nu) \zeta(2\nu) \end{aligned}$$

and

$$\int_0^{\infty} \frac{g_M(t)}{t} dt = \frac{2(-1)^{\frac{M+1}{2}}}{(2\pi)^M} \cdot \frac{\pi}{2} \zeta(M).$$

$$q^\alpha - \frac{1}{2} p^M = -\frac{1}{2} (M)_\alpha p^M + \{(M-3)_{\alpha-1} + (M-3)_{\beta-1}\} p^{M-2} \\ + \{(M-5)_{\alpha-1} + (M-5)_{\beta-1}\} p^{M-4} \\ \dots \\ + \{(2)_{\alpha-1} + (2)_{\beta-1}\} p^3, \\ (\alpha + \beta = M \text{ odd}, \alpha \text{ odd}, \alpha > 1)$$

and

$$q^{M-1} - \frac{1}{2} p^M = \frac{M}{2} p^M - p^{M-2} - p^{M-4} - \dots - p^3, \\ (M \text{ odd}),$$

while we may further always make use of the relation

$$q^\alpha + q^\beta = p^\alpha + p^\beta = p^\beta + p^\alpha$$

if α and β are both greater than 1.

On page 183 EULER thinks to be allowed to write the results mentioned here on the ground of what he found for the special cases $M = 3, 5, 7, \dots, 15$. In his general formulae the signs, however, are not quite correct, which appears, when they are compared with his results for the case $M = 11$, which are mentioned at length on the preceding page.

The preceding method for determining $\varphi(\alpha, \beta)$ does not apply to the case: $\alpha + \beta = M$ is even. In order to arrive at some result in this case EULER's method may be followed in substance. Some modifications, however, are necessary, for the divergent series admitted by EULER, must be avoided.

We consider the function

$$\varepsilon(a, b, \alpha) = \sum_{n=2}^{\infty} \frac{e^{n\alpha}}{n^a} \left\{ \frac{1}{1^b} + \frac{1}{2^b} + \dots + \frac{1}{(n-1)^b} \right\} = \sum_{\substack{n=2 \\ \lambda < n}}^{\infty} \frac{e^{n\alpha}}{n^a (n-\lambda)^b}$$

and decompose each fraction

$$\frac{1}{n^a (n-\lambda)^b}$$

into a sum of fractions with the denominators

$$n\lambda^{M-1}, \quad n^2\lambda^{M-2}, \dots, n^a\lambda^b, \\ (n-\lambda)\lambda^{M-1}, \quad (n-\lambda)^2\lambda^{M-2}, \dots, (n-\lambda)^b\lambda^a,$$

in which M is put for $a + b$.

Thus the function $\varepsilon(a, b, \alpha)$ is decomposed into series of the form

$$\sum_{\substack{n=2 \\ \lambda < n}}^{\infty} \frac{e^{n\alpha}}{n^{M-k}\lambda^k} = \varepsilon(M-k, k, \alpha)$$

and in others of the form

$$\sum_{\substack{n=2 \\ \lambda < n}}^{\infty} \frac{e^{n\alpha}}{(n-\lambda)^{M-k}\lambda^k} = \sum_{\lambda=1}^{\infty} \frac{e^{\lambda\alpha}}{\lambda^k} \cdot \sum_{\lambda=1}^{\infty} \frac{e^{\lambda\alpha}}{\lambda^{M-k}} = \varepsilon(k, \alpha) \cdot \varepsilon(M-k, \alpha).$$

If the separation is carried out completely, we find

$$\begin{aligned} \varepsilon(a, b, a) = & (-1)^b \sum_{k=b}^{k=M-1} (k-1)_{b-1} \varepsilon(M-k, k, a) + \\ & + (-1)^a \sum_{k=a}^{k=M-1} (-1)^k (k-1)_{a-1} \varepsilon(k, a) \varepsilon(M-k, a). \end{aligned}$$

If a is made to tend to zero, we have again in EULER's notation

$$\varepsilon(M-k, k, 0) = q^{M-k} - p^M, \quad \varepsilon(k, 0) = p^k,$$

but $\varepsilon(1, M-1, a)$ and $\varepsilon(1, a)$ would, for $a = 0$, become divergent series. For these functions, however, holds true

$$\lim_{\alpha \rightarrow 0} \{\varepsilon(1, M-1, \alpha) - \varepsilon(1, \alpha) \varepsilon(M-1, \alpha)\} = -q^{M-1}$$

and making use of this, we find for $\alpha > 1$, consequently $b < M-1$

$$\begin{aligned} \{q^a - p^M\} \{(-1)^{b-1}\} = & \sum_{k=b+1}^{k=M-2} (k-1)_{b-1} (q^{M-k} - q^M) + \\ & + (-1)^M \sum_{k=a}^{k=M-2} (-1)^k (k-1)_{a-1} p^k - (M-2)_{b-1} q^{M-1}. \end{aligned}$$

For the case $a = 1, b = M-1$ the difference M even or odd appears.

For M odd both sides vanish identically, for $M = 2N$, we find on the contrary

$$q^{2N-1} = p^2 - p^3 + p^4 - \dots + (-1)^N \cdot \frac{1}{2} p^N,$$

a result for $\varphi(2N-1, 1)$ that shows some resemblance with the one that was obtained for $\varphi(M-1, 1)$ in the case M odd.

In the equation deduced above we may now successively write $a = 2, 3, \dots, M-1$. In this way a number of equations is found, from which it would seem possible to solve q^2, q^3, \dots, q^{M-1} . EULER considers a similar system of equations for the special cases $M = 3, 4, \dots, 15$. He finds that several relations of dependence exist between these which are partly connected with the general relation

$$q^a + q^{M-a} = p^a + p^M.$$

If M is odd there remain just enough independent equations in

the cases considered by EULER to solve $q^2, q^3, \dots, q^{\frac{M-1}{2}}$ and q^{M-1} , for $M = 2N$, however, q^{2N-1} is in general the only unknown quantity that can be solved, while there moreover remain, apart from the relation $2q^N = p^N + p^{2N}$, which procures the value of q^N , a certain number of relations between the quantities q^2, q^3, \dots, q^{N-1} .

For the case $M = 6$ there remains, as soon as q^3 and q^5 have been found, just *one* relation, which then allows to determine q^2 . For $M = 8$ we find q^7 and q^4 and further *one* relation between q^2 and q^3 . In the same way q^6 and q^5 may be solved for $M = 10$ and two relations subsist between q^2, q^3 and q^4 .

Physics. — “On the use of Third Degree Terms in the Energy of a Deformed Elastic Body.” By J. TRESLING. (Communicated by Prof. H. A. LORENTZ).

(Communicated in the meeting of May 27, 1916).

§ 1. We shall indicate the deviations to which a point x, y, z of an elastic body is subjected in a deformation by ξ, η, ζ .

It is easily shown ¹⁾ that this change of form can be obtained by making the dimensions in 3 definite directions normal to each other resp. $\sigma_1, \sigma_2, \sigma_3$ times smaller, and by then rotating the body. If we write S_i for $\frac{1}{\sigma_i^2}$, the three values of S_i are determined as the three roots of the equation:

$$S^3 - (3 + 2J_1)S^2 + (3 + 4J_1 + 4J_2)S - (1 + 2J_1 + 4J_2 + 8J_3) = 0$$
in which:

$$J_1 = \varepsilon_1 + \varepsilon_2 + \varepsilon_3$$

$$J_2 = \varepsilon_2\varepsilon_3 + \varepsilon_3\varepsilon_1 + \varepsilon_1\varepsilon_2 - \frac{1}{4}(\gamma_1^2 + \gamma_2^2 + \gamma_3^2)$$

$$J_3 = \varepsilon_1\varepsilon_2\varepsilon_3 + \frac{1}{4}(\gamma_1\gamma_2\gamma_3 - \varepsilon_1\gamma_1^2 - \varepsilon_2\gamma_2^2 - \varepsilon_3\gamma_3^2)$$

and the $\varepsilon_1 \dots \gamma_3$ are the following functions of the 9 differential quotients $\frac{\partial \xi}{\partial x} \dots$ etc.:

$$\varepsilon_1 = \frac{\partial \xi}{\partial x} + \frac{1}{2} \left[\left(\frac{\partial \xi}{\partial x} \right)^2 + \left(\frac{\partial \eta}{\partial x} \right)^2 + \left(\frac{\partial \zeta}{\partial x} \right)^2 \right]$$

$$\varepsilon_2 = \frac{\partial \eta}{\partial y} + \frac{1}{2} \left[\left(\frac{\partial \xi}{\partial y} \right)^2 + \left(\frac{\partial \eta}{\partial y} \right)^2 + \left(\frac{\partial \zeta}{\partial y} \right)^2 \right]$$

$$\varepsilon_3 = \frac{\partial \zeta}{\partial z} + \frac{1}{2} \left[\left(\frac{\partial \xi}{\partial z} \right)^2 + \left(\frac{\partial \eta}{\partial z} \right)^2 + \left(\frac{\partial \zeta}{\partial z} \right)^2 \right]$$

$$\gamma_1 = \frac{\partial \eta}{\partial z} + \frac{\partial \zeta}{\partial y} + \frac{\partial \xi}{\partial y} \frac{\partial \xi}{\partial z} + \frac{\partial \eta}{\partial y} \frac{\partial \eta}{\partial z} + \frac{\partial \zeta}{\partial y} \frac{\partial \zeta}{\partial z}$$

$$\gamma_2 = \frac{\partial \zeta}{\partial x} + \frac{\partial \xi}{\partial z} + \frac{\partial \xi}{\partial z} \frac{\partial \xi}{\partial x} + \frac{\partial \eta}{\partial z} \frac{\partial \eta}{\partial x} + \frac{\partial \zeta}{\partial z} \frac{\partial \zeta}{\partial x}$$

$$\gamma_3 = \frac{\partial \xi}{\partial y} + \frac{\partial \eta}{\partial x} + \frac{\partial \xi}{\partial x} \frac{\partial \xi}{\partial y} + \frac{\partial \eta}{\partial x} \frac{\partial \eta}{\partial y} + \frac{\partial \zeta}{\partial x} \frac{\partial \zeta}{\partial y}$$

The J_1, J_2, J_3 are invariant in case of axial rotation. The free energy of an elastic isotropic body will be a symmetric function of $\sigma_1, \sigma_2, \sigma_3$.

If we confine ourselves to terms which are of the 2nd and 3rd

¹⁾ DUHEM, Recherches sur l'élasticité, 1906.

degree with respect to the 9 differential quotients, we may write for that free energy :

$$\varphi d\tau = [(\frac{1}{2}\lambda + \mu) J_1^2 - 2\mu J_2 + CJ_1^3 + DJ_1J_2 + EJ_3] d\tau,$$

in which $d\tau$ is the volume element of the undeformed body. In strained condition it is $d\tau'$.

The variation of energy after a virtual transformation from a strained condition amounts to :

$$\frac{\partial \varphi}{\partial \varepsilon_1} d\varepsilon_1 + \dots + \frac{\partial \varphi}{\partial \gamma_3} d\gamma_3.$$

The virtual transformation is determined by its 6 strain components $D_1, D_2, D_3, G_1, G_2, G_3$.

The $d\varepsilon_1 \dots d\gamma_3$ can be expressed linearly in these. The variation of energy amounts to :

$$(X_1 D_1 + Y_1 D_2 + Z_1 D_3 + 2 Y_2 G_1 + 2 Z_2 G_2 + 2 X_3 G_3) d\tau'$$

in which

$$\begin{aligned} - (1 + J_1) X_x &= \left(1 + \frac{\partial \xi}{\partial x}\right)^2 \frac{\partial \varphi}{\partial \varepsilon_1} + \left(\frac{\partial \xi}{\partial y}\right)^2 \frac{\partial \varphi}{\partial \varepsilon_2} + \left(\frac{\partial \xi}{\partial z}\right)^2 \frac{\partial \varphi}{\partial \varepsilon_3} + \\ &+ 2 \frac{\partial \xi}{\partial y} \frac{\partial \xi}{\partial z} \frac{\partial \varphi}{\partial \gamma_1} + 2 \frac{\partial \xi}{\partial z} \left(1 + \frac{\partial \xi}{\partial x}\right) \frac{\partial \varphi}{\partial \gamma_2} + 2 \left(1 + \frac{\partial \xi}{\partial x}\right) \frac{\partial \xi}{\partial y} \frac{\partial \varphi}{\partial \gamma_3} \end{aligned}$$

with two analogons for Y_y and Z_z .

$$\begin{aligned} - (1 + J_1) Y_z &= \frac{\partial \eta}{\partial x} \frac{\partial \xi}{\partial x} \frac{\partial \varphi}{\partial \varepsilon_1} + \left(1 + \frac{\partial \eta}{\partial y}\right) \frac{\partial \xi}{\partial y} \frac{\partial \varphi}{\partial \varepsilon_2} + \frac{\partial \eta}{\partial z} \left(1 + \frac{\partial \xi}{\partial z}\right) \frac{\partial \varphi}{\partial \varepsilon_3} + \\ &+ \left\{ \left(1 + \frac{\partial \eta}{\partial y}\right) \left(1 + \frac{\partial \xi}{\partial z}\right) + \frac{\partial \eta}{\partial z} \frac{\partial \xi}{\partial y} \right\} \frac{\partial \varphi}{\partial \gamma_1} + \left\{ \frac{\partial \eta}{\partial z} \frac{\partial \xi}{\partial x} + \frac{\partial \eta}{\partial x} \left(1 + \frac{\partial \xi}{\partial z}\right) \right\} \frac{\partial \varphi}{\partial \gamma_2} + \\ &+ \left\{ \frac{\partial \eta}{\partial x} \frac{\partial \xi}{\partial y} + \left(1 + \frac{\partial \eta}{\partial y}\right) \frac{\partial \xi}{\partial x} \right\} \frac{\partial \varphi}{\partial \gamma_3} \end{aligned}$$

with two analogons for Z_z and X_x ..

They give the stress components as sum of differential quotients of the φ with respect to the strain components.

§ 2. In § 1 we have placed side by side the formulae of DUHEM, which we shall require for the comparison of two papers¹⁾ on the changes which take place in the dimensions when a strained steel wire is twisted. In this § we shall give the results of their application in some special cases.

Let us give to a body a dilatation α, β, γ , resp. in the x, y , and z

¹⁾ H. A. LORENTZ. The expansion of Solid Bodies by Heat. Verslag Kon. Ak. Oct. 1915 p. 671. POYNTING. On the changes in the Dimensions of a Steel Wire when Twisted and on the Pressure of Distortional Waves in Steel. Proc. Royal Soc. (A) 86, 1912, p. 534.

direction, which causes the point x, y, z to get at the place x', y', z' ; $x' = x(1 + \alpha)$, $y' = y(1 + \beta)$, $z' = z(1 + \gamma)$. Then we may inquire into the tensions which occur in a new deformation, and also into the increase of energy that takes place then.

I have carried out this calculation for two special cases.

If the said dilatations are followed by a shear

$$x'' = x' + \varepsilon z' \quad y'' = y' \quad z'' = z', \quad \dots \quad (1)$$

then :

$$X_z(1 + \alpha + \beta + \gamma) = \frac{\partial \varphi}{\partial \varepsilon}$$

$$\varphi d\tau = \varphi_0 d\tau + \frac{\varepsilon^2}{2} \left[\mu \left(1 - \frac{\alpha}{2} - \beta + \frac{3}{2} \gamma \right) + \left(\lambda + \frac{5}{2} \mu - \frac{D}{2} \right) (\alpha + \beta + \gamma) - \frac{E + 3\mu}{2} \beta \right] d\tau \quad \dots \quad (2)$$

In φ_0 the terms are comprised which are independent of ε . We may also write :

$$X_z = \varepsilon \left[\mu \left(1 - \frac{3}{2} \alpha - 2\beta + \frac{1}{2} \gamma \right) + \left(\lambda + \frac{5}{2} \mu - \frac{D}{2} \right) (\alpha + \beta + \gamma) - \frac{E + 3\mu}{2} \beta \right] \quad \dots \quad (3)$$

If, however, after the same dilatations α, β, γ we apply the shear ε in such a way that the new change of position of the particles is expressed by :

$$x'' = x' + \frac{\varepsilon}{2} z' \quad y'' = y' \quad z'' = \frac{\varepsilon}{2} x' + z' \quad \dots \quad (4)$$

we find other values, namely :

$$\varphi d\tau = \varphi_0 d\tau + \frac{\varepsilon^2}{2} \left[\mu + \left(\frac{\lambda}{2} + \frac{5}{2} \mu - \frac{D}{2} \right) (\alpha + \gamma) - \left(-\frac{\lambda}{2} + \frac{D}{2} + \frac{E}{2} \right) \beta \right] d\tau \quad \dots \quad (5)$$

$$X_z = \varepsilon \left[\mu \left(1 - \frac{\alpha}{2} - 2\beta - \frac{\gamma}{2} \right) + \left(\lambda + \frac{5}{2} \mu - \frac{D}{2} \right) (\alpha + \beta + \gamma) - \frac{E + 3\mu}{2} \beta \right] \quad (6)$$

We see that in this case X_z cannot be obtained by differentiating φ with respect to ε , as in the preceding one.

As third application we calculate, accurate down to ε^2 , the tensions which occur when a body is deformed out of its natural position according to the equations :

$$x' = x + \varepsilon z \quad y' = y \quad z' = z.$$

We then find :

$$\left. \begin{aligned} X_x &= \frac{1}{2} \epsilon^2 \left(-\lambda - 3\mu + \frac{D}{2} - \mu \right) \\ Y_y &= \frac{1}{2} \epsilon^2 \left(-\lambda + \frac{D}{2} + \frac{E}{2} \right) \\ Z_z &= \frac{1}{2} \epsilon^2 \left(-\lambda - 3\mu + \frac{D}{2} + \mu \right) \\ Y_z &= 0 \quad Z_x = -\mu\epsilon \quad X_y = 0 \end{aligned} \right\} \dots \dots \dots (7)$$

§ 3. After POYNTEG had first given considerations about the changes of the dimensions in a twisted wire, which he had to relinquish later on, a supposition is made in his more recent consideration, which is not evident from the standpoint of a third degree potential energy.

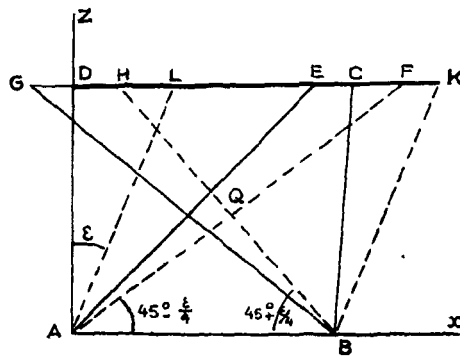

If we transform a cube $ABCD$ by a shear over an angle ϵ to $ABKL$, the line GB , which undergoes the greatest contraction will get into BH after the deformation, so that angle $ABH = 45^\circ + \frac{\epsilon}{4}$. The line AF , which has been most stretched, will make an angle $45^\circ - \frac{\epsilon}{4}$ with AB . This holds for terms up to ϵ^2 inclusive. POYNTEG's supposition now runs that only a normal pressure acts on AQ , and only a normal tension on BQ , and that therefore no tangential stresses exist along AQ and BQ , not of the 2nd order either. POYNTEG introduces two new elasticity constants p and q ; he does so in the following way. The pressure on AQ will amount to $\mu\epsilon + p\epsilon^2$ in 2nd approximation, that on BQ will have a value $-\mu\epsilon + p\epsilon^2$, and the pressure normal to the plane of drawing $q\epsilon^2$.

The problem raised is the following one. A long, thin cylindrical rod is twisted over an angle θ without being pressed sideways or on the end planes. Required is the increase in length, the decrease in thickness, and the shortening of the radius at any point in a

section. If the three formulae have been found for this, the first two will make it possible to derive the values of p and q from the observed change of the dimensions. The third formula is a relation that is not practically controllable.

We now first examine what relation there is between the quantities p , q , and those which we have above introduced. POYNTING calculates from his suppositions that a normal pressure $(\frac{1}{2}\mu + p)\epsilon^2$ acts on AB , and a normal pressure $(-\frac{1}{2}\mu + p)\epsilon^2$ on AD , the tangential stresses $\mu\epsilon$ existing besides. This appears to agree entirely with our equations (7), and the relation between the elasticity constants of POYNTING and ours is expressed by

$$p = \frac{D}{4} - \frac{\lambda}{2} - \frac{3\mu}{2} \quad q = \frac{D}{4} + \frac{E}{4} - \frac{\lambda}{2}.$$

With these values of p and q we can follow the reasoning of POYNTING. The result can be represented as follows in another notation. A rod of a length l and a section with the radius R , on being twisted over an angle θ , and not subjected to any external pressure, becomes longer in the ratio of 1 to $1 + \gamma$, its radius changes in ratio of 1 to $1 + \sigma$. A point at a distance r from the axis will get at a distance $r(1 + s)$ from it. The quantities γ , σ , and s are found from:

$$\left. \begin{aligned} 2\lambda\gamma + 4(\lambda + \mu)\sigma &= -\frac{\theta^2 R^2}{4l^2}(\mu - 2p - 2q) \\ (\lambda + 2\mu)\gamma + 2\lambda\sigma &= \frac{\theta^2 R^2}{4l^2}(\mu + 2p) \\ s &= \frac{\theta^2}{16l^2} \frac{\mu - 2p + 6q}{\lambda + 2\mu} (r^2 - R^2) + \sigma \end{aligned} \right\} \dots (8)$$

(formulae (8), (9), and (10) in the cited paper by POYNTING).

Observed were σ and γ . The two first formulae gave the possibility to find the quantities p and q for a definite steel wire. For that wire $\lambda = 9,77 \times 10^{11}$; $\mu = 8,35 \times 10^{11}$. The values for p and q were then $p = 1,67 \times 10^{12}$; $q = -0,70 \times 10^{12}$, hence $D = 13,6 \times 10^{12}$, $E = -14,5 \times 10^{12}$, all this expressed in C, G, S unities.

Prof. LORENTZ treats the same problem, for which other constants of elasticity a and b are introduced. The three equations (29), (30), and (28) in his paper can, however, not be made to agree all at the same time with the equations (8) by a suitable connection between p , q on one side, and a , b on the other side. The coefficients a and b introduced by LORENTZ occur as follows. When a body which has undergone the dilatations α, β, γ in the

directions of the coordinates, by which the point x, y, z has got into x', y', z' , then undergoes a shear ε in the x, z -plane, which causes that point to be displaced to $\varepsilon x'', y'', z''$, Prof. LORENTZ puts $X_z = \mu' \left(\frac{\partial z'}{\partial x'} + \frac{\partial x''}{\partial z'} \right)$ and the increase of the density of energy $= \frac{1}{2} \mu' \left(\frac{\partial z''}{\partial x'} + \frac{\partial x''}{\partial z'} \right)^2$, in which μ' is a coefficient of rigidity changed by the preceding dilatations α, β, γ . Prof. LORENTZ puts for this $\mu' = \mu + a(\alpha + \gamma) + b\beta$. That α and γ only occur here in the combination $\alpha + \gamma$ is proved on the supposition that the tension X_z depends really only on $\frac{\partial z''}{\partial x'} + \frac{\partial x''}{\partial z'}$, which does not appear to be the case, when we compare formulae (3) and (6), which give us the tensions for two deformations with equal $\frac{\partial z''}{\partial x'} + \frac{\partial x''}{\partial z'} = \varepsilon$. The proof remains valid when we effect the shear according to (4); then, however, the increase of energy is not given by $\frac{1}{2} \mu' \varepsilon^2$; which we see by (5) and (6). In our problem, we must however shear according to (1). Then α and γ do not occur any longer only in the combination $\alpha + \gamma$, and for the increase of energy we must use formula (2).

Starting from this and following for the rest Prof. LORENTZ'S reasoning, we come to the same result as POYNTING.

Appendix by H. A. LORENTZ.

Mr. TRESLING is right. On account of an error in the reasoning of which I have made use in the note on p. 673 of my communication, my formula (21) is not correct; it should run:

$$\mu' = \mu(1 + 2z) + a(\mathbf{x} + \mathbf{z}) + b\mathbf{y}.$$

Consequently in the expression derived from it for the change of the free energy per volume unity $\mu(1 + 2q + 2s)$ should be substituted for $\mu(1 + 2s)$, and in the second integral (22) $+q$ for $-q$. Then $\mu + a$ comes in the place of $-\mu + a$, in the expression for Q on p. 675, and equation (30) becomes:

$$(\lambda + 2\mu)q + 2\lambda s = -\frac{\Theta^2 R^2}{4l^2}(\mu + a).$$

If we replace in this, and also in (28) and (29):

$$\begin{array}{ccccccc} q & , & \mathbf{s} & , & a & \text{and} & b \\ \text{by} & & \gamma & , & \sigma & , & -2\mu - 2p \quad ,, \quad -\mu - 2q, \end{array}$$

we get exactly the above formulae (8).

I shall communicate on a later occasion what modifications my further calculations now must undergo.

Physics. — “On the Fundamental Values of the Quantities b and \sqrt{a} for Different Elements, in Connection with the Periodic System. III. Discussion of the Different Groups of Elements Separately.” By Dr. J. J. VAN LAAR. (Communicated by Prof. H. A. LORENTZ).

(Communicated at the meeting of May 27, 1916).

1. In the preceding Paper¹⁾ in § 3 we saw that b_k can be obtained from the liquid volume v_1 (at such a low temperature that the vapour density may be neglected) through the formula

$$b_k = v_1 \times 2\gamma \left[1 - \frac{\gamma}{1 + \gamma} m_1 \right], \quad \dots \quad (1)$$

in which γ represents the (reduced) coefficient of direction of the straight diameter between D_1 and D_k in a D, T -diagram, and m_1 is the reduced (absolute) temperature $T_1 : T_k$.

We might even continue to use this formula, when v_1 represents the volume in *solid* state — when namely the law of the variability of v with T does not deviate too much from that holding for the liquid state. But in case v_1 is only known for the solid state, we can also first reduce v_1 to the value of v at the triple point (by means of the experimentally determined formulae for the expansivity), and then apply the above formula (1) starting from that point.

A great difficulty is experienced for elements the melting point of which lies very high, and for which the value of γ is perfectly unknown; besides — when also that of v at the melting point is unknown — the value of γ can in many cases no longer be calculated from the empiric formulae of expansion in the solid state, seeing that mostly these are only valid for temperatures far below the melting point. In such cases there is often nothing left but to apply formula (1) as a first approximation also to the solid state, and determine the value of γ from other data. In many cases the formula (valid for the liquid state)

$$2\gamma = 1 + 0,038 \sqrt{T_k} \quad \dots \quad (2)$$

can be used for it, which formula was lately derived by me²⁾. It will be remembered that 2γ is also $= b_k : b_0$, and therefore expresses the degree of the variability of b .

¹⁾ Denoted by II in what follows; cf. These Proc. of March 25, 1916. Paper I appeared in These Proc. of Jan. 29, 1916.

Cf. also Journal de Chimie physique, T. 14, N^o. 1 (March 31, 1916).

²⁾ Cf. the series of papers, cited by me already in I (Footnote 3) on p. 1221, particularly the 3^d paper of May 29, 1914, p. 1051.

It is to be expected that probably the value of $b_1 : v_1$ at the *triple point* will possess the same value for certain groups of elements. *That in other words the solid state then occurs when the molecular volume shall have become a definite fraction of the total volume.*

To investigate this we shall determine the general value of $b_1 : v_1$ from the equation of state (when, namely, at the triple point p can be neglected)

$$\frac{a_1}{v_1^2} (v_1 - b_1) = RT_1,$$

from which follows:

$$\frac{v_1 - b_1}{v_1^2} = \frac{RT_1}{a_1} \cdot \frac{a_k}{a_1}.$$

Now $RT_k = \frac{8}{27} \lambda \frac{a_k}{b_k}$, in which λ lies between 1 and $27/28$ (for substances with high critical temperature). For most substances with which we shall occupy ourselves in what follows, we may put $RT_k = \frac{2}{7} \frac{a_k}{b_k}$, hence $a_k = RT_k \cdot b_k$. In consequence we get:

$$\frac{v_1 - b_1}{v_1^2} = \frac{2}{7} \frac{a_k m_1}{a_1 b_k} = \varphi \frac{m_1}{b_k},$$

in which (a_k and a_1 not differing much) the factor φ will never be far from $2/7$. Hence we find:

$$\frac{v_1 - b_1}{v_1} = \varphi \frac{v_1}{b_k} m_1.$$

If therefore $b_1 : v_1$ or $(v_1 - b_1) : v_1$ has a constant value, also the value of $v_1 : b_k \times m_1$ must be constant. In this $b_k : v_1$ is the factor of the above formula (1), which we shall call f_1 , so that

$$f_1 = 2\gamma \left[1 - \frac{\gamma}{1 + \gamma} m_1 \right] \dots \dots \dots (a)$$

Hence

$$\frac{v_1 - b_1}{v_1} = \varphi \frac{m_1}{f_1} \dots \dots \dots (3)$$

If e.g. $f_1 : m_1 = 6$, then $(v_1 - b_1) : v_1 = 2/7 \times 1/6 = 1/21$, so that then the solid state would occur, when the free (available) space between the molecules has become $1/21$ of the total volume.

If instead of $m_1 = T_1 : T_k$ the reciprocal quantity $\mu_1 = T_k : T_1$ is introduced, then becomes:

$$\frac{v_1 - b_1}{v_1} = \frac{\varphi}{f_1 \mu_1} \dots \dots \dots (3a)$$

in which:

$$f_1 = 2\gamma \left[1 - \frac{\gamma}{1+\gamma} \frac{1}{\mu_1} \right], \dots \dots \dots (\beta)$$

hence

$$f_1 \mu_1 = 2\gamma \left[\mu_1 - \frac{\gamma}{1+\gamma} \right] \dots \dots \dots (\gamma)$$

For the verification of the possible constancy of the ratio $(v_1 - b_1) : v_1$ at the *triple point* we shall try to determine in what follows the value of $f_1 \times \mu_1$ for every group of homologous elements. It will then appear at the same time what law the ratio $\bar{\mu} = T_k : T_1$ obeys, about which ratio we now only know that it can vary between $5^{1/3}$ and $1^{1/3}$.

Let us now proceed to examine the different groups of the periodic system separately.

II. The Hydrogen-Helium group.

a. Hydrogen.

If d_1' may be neglected at the triple point, it follows from $\frac{1}{2} d_1 = 1 + \gamma(1 - m_1)$, as $d_1 = D_1 : D_k$, that:

$$2\gamma = \frac{d_1 - 2}{1 - m_1} = \frac{T_k}{D_k} \cdot \frac{D_1 - 2D_k}{T_k - T_1}$$

With $T_k = 31,95$, $D_k = 0,03025$, $T_1 = 13,95$, $D_1 = 0,07709$ we find:

$$2\gamma = 1056 \times \frac{0,01659}{18,0} = 0,9734, \text{ accordingly } \gamma = 0,487,$$

so that we have according to (a) with $m_1 = 0,437$:

$$f_1 = 0,973 \left[1 - \frac{0,487}{1,487} \times 0,437 \right] = 0,973 (1 - 0,143) = 0,834.$$

As v_1 (expressed in normal units) is $= 58,3 \times 10^{-5}$ according to the subjoined table A, it would follow from this that $b_k = 58,3 \times 10^{-5} \times 0,834 = 48,7 \times 10^{-5}$.

The value $48,5 \times 10^{-5}$ has been found directly from T_k and p_k (see I).

We find 2,29 for $\mu_1 = T_k : T_1$, hence we have here:

$$f_1 \times \mu_1 = 0,834 \times 2,29 = 1,91.$$

b. Helium.

As the value of γ cannot be calculated here yet with certainty from the few data concerning d_1 and d_2 (from them a theoretically impossible value of γ would namely follow, much smaller than 0,5), I have calculated the theoretical value from (2). We find $2\gamma = 1 + 0,038 \sqrt{5,2} = 1 + 0,038 \times 2,28 = 1,0866$, hence $\gamma = 0,543$.

19,

[For H_2 we should have found $2\gamma = 1,2148$, $\gamma = 0,607$ by means of this formula, with $\sqrt{31,95} = 5,65$. With $D_1 = 0,07709$ ($v_1 = 58,3 \times 10^{-5}$) this value would, however, have yielded much too high a value for b_k].

For He with $m = 1,48 : 5,20 = 0,285$ ($T = 1,48$ lies above the triple point temperature, but is the lowest temperature at which a density determination has as yet been made) we get:

$$f = 1,087 \left[1 - \frac{0,543}{1,543} \times 0,285 \right] = 1,087 (1 - 0,100) = 0,978.$$

As $v = 122,1 \times 10^{-5}$ is found from $D = 0,146$, we find the value 119×10^{-5} for b_k , 105×10^{-5} having been found directly from T_k and p_k . Hence the given value of D at $1^\circ,48$ (absolute) is probably somewhat too low.

If we calculate the value of f_1 , which would correspond with the probable triple point ($\pm 1^\circ$ absolute), we find with $m_1 = 0,192$:

$$f_1 = 1,087 [1 - 0,352 \times 0,192] = 1,087 (1 - 0,0677) = 1,013.$$

As $\mu_1 = 5,20$, we find for He (approximately):

$$f_1 \times \mu_1 = 1,013 \times 5,20 = 5,27.$$

c. Neon.

We again calculate the coefficient of direction of the straight diameter from formula (2), giving with $\sqrt{45} = 6,708$ for 2γ the value $1,2549$, hence $\gamma = 0,627$.

We then find for f_1 with $m_1 = 24,42 : 45 = 0,543$:

$$f_1 = 1,255 \left[1 - \frac{0,627}{1,627} \times 0,543 \right] = 1,255 (1 - 0,209) = 0,992$$

For b_k (from $D_1 = 1,251$, $v_1 = 72,1 \times 10^{-5}$) this gives the value $71,5 \times 10^{-5}$, 71×10^{-5} being found directly from T_k and p_k .

For μ_1 we find $1,84$, so that we get for $f_1 \times \mu_1$:

$$f_1 \times \mu_1 = 0,992 \times 1,84 = 1,83.$$

d. Argon.

Experimentally $\gamma = 0,745$ has been found (formula (2) would have yielded $2\gamma = 1,4663$, $\gamma = 0,733$ with $\sqrt{150,65} = 12,27$), so that we find with $m_1 = 83,79 : 150,65 = 0,556$:

$$f_1 = 1,490 \left[1 - \frac{0,745}{1,745} \times 0,556 \right] = 1,49 (1 - 0,237) = 1,136.$$

The density at the triple point is $1,413$, from which follows $v_1 = 126,1 \times 10^{-5}$. Hence $b_k = v_1 \times f_1$ becomes $= 143 \times 10^{-5}$. (Directly from T_k and p_k was found 144×10^{-5}).

Further is

$$f_1 \times \mu_1 = 1,136 \times 1,80 = 2,04.$$

e. Krypton.

Formula (2) yields with $\sqrt{210,6} = 14,51$ the value $2\gamma = 1,5514$, $\gamma = 0,776$, giving:

$$f_1 = 1,551 \left[1 - \frac{0,776}{1,776} \times 0,494 \right] = 1,551 (1 - 0,216) = 1,216,$$

as $m_1 = 104,1 : 210,6 = 0,494$.

Now RAMSAY and TRAVERS¹⁾ give the density 2,155 for 127°,1 abs. ($m = 0,6035$). The factor f corresponding with this temperature is

$$f = 1,551 (1 - 0,437 \times 0,6035) = 1,551 (1 - 0,264) = 1,142.$$

With $D = 2,155$ corresponds $v = 171,7 \times 10^{-5}$, so that b_k would become $= 196 \times 10^{-5}$, while 177×10^{-5} was found directly from T_k and p_k . The given density is therefore too small.

We find for the product $f_1 \times \mu_1$:

$$f_1 \times \mu_1 = 1,216 \times 2,02 = 2,46.$$

f. Xenon.

From the experiments of PATTERSON, CRIPPS and WHYTLAW GRAY (1912) follows $\gamma = 0,780$, while from (2) is calculated $2\gamma = 1,6468$, $\gamma = 0,823$, as $\sqrt{289,7} = 17,02$.

With $\gamma = 0,780$ we find from $\frac{1}{2} d_1 = 1 + \gamma(1 - m_1)$, in which $m_1 = 133,1 : 289,7 = 0,459$, for d_1 the value 2,843. Hence the value²⁾ 3,281 is found for D_1 with $D_k = 1,154$, hence $v_1 = 177,1 \times 10^{-5}$.

Now

$$f_1 = 1,560 \left[1 - \frac{0,78}{1,78} \times 0,459 \right] = 1,560 (1 - 0,201) = 1,246.$$

Hence b_k becomes $= 221 \times 10^{-5}$, while the value 228×10^{-5} has been directly found from T_k and p_k .

We have further:

$$f_1 \times \mu_1 = 1,246 \times 2,18 = 2,71.$$

g. Niton (Radium-emanation).

We can again calculate the value of γ from $\sqrt{T_k} = \sqrt{377,6} = 19,43$, which gives $2\gamma = 1,738$, $\gamma = 0,869$. For the boiling point, where $D = 1 : 0,2281 = 4,384$, hence $v = 226,3 \times 10^{-5}$ has been found by RUDOLF (1910) (all the other recorded values

¹⁾ Zeitschr. f. physik. Ch. 38, 674 (1901).

²⁾ Some time ago RAMSAY and TRAVERS (loc. cit.) found $D = 3,52$ at 171°,1 abs. As for the boiling point (166°,2 abs.) the liquid density was found only $= 3,06$ by P., C., W.G., D must be found somewhat smaller than 3,06 for 171°,1. In his interesting study on the periodic system (Zeitschr. für physik. Ch. 76, 577 (1911)) BAUR is very near the truth, when he surmises that the much too high value 3,52 must be replaced by about 3,07.

TABLE A.
The Hydrogen-Helium Group.

	A	$\frac{A}{N}$	D_1	$\frac{A}{D_1}$	$v_1 = \text{id.}$ 22412	γ	γ'	m_1	f_1	$b_k \cdot 10^5$ calculated	$b_k \cdot 10^5$ found	$\sqrt{a_k} \cdot 10^2$ id.
1 H ₂	1,008	1,01	0,07709 (K. O., Cr)	13,07	$58,3 \cdot 10^{-5}$	0,487	0,607	0,437	0,834	48,7	48,5	3,2 (1,6)
2 He	3,994	2,00	0,146 (K. O.) ¹⁾	27,36	122,1	—	0,543	0,192	1,013	119	105	0,8
10 Ne	20,200	2,02	1,251 (Cr.)	16,15	72,1	—	0,627	0,543	0,992	71,5	71	2,7
18 Ar	39,945	2,22	1,413 (K. O., Cr.)	28,27	126,1	0,745	0,733	0,556	1,136	143	144	5,2
36 Kr	82,92	2,30	2,155 (R., Tr) ²⁾	38,48	171,7	—	0,776	0,494	1,216	196	177	6,9
54 X	130,22	2,41	3,281 (P, Cr, W.G.)	39,69	177,1	0,780	0,823	0,459	1,246	221	228	9,1
86 Ni (Eman.)	222,4	2,59	4,384 (RUDORF) ³⁾	50,73	226,3	—	0,869	0,535	1,305	291	277	11,5

¹⁾ For 1°48 abs.

²⁾ For 127°1 abs. RUDORF (Das periodische System, 1904) gives the somewhat higher value 2,185 (p. 317).

³⁾ For 211°1 abs.

have been found by RAMSAY and GRAY, Z. f. ph. Ch. **70**, p. 121) this yields the equation.

$$f = 1,738 \left[1 - \frac{0,869}{1,869} \times 0,559 \right] = 1,738 (1 - 0,260) = 1,286.$$

For T_s we have namely $m = 211,1 \quad 377,6 = 0,559$. We therefore calculate $b_k = 291 \times 10^{-5}$, whereas $b_k = 277 \times 10^{-5}$ is directly found from T_k and p_k ¹⁾.

At the triple point $m_1 = 202,1 \quad 377,6 = 0,535$, through which f_1 becomes $= 1,738 (1 - 0,249) = 1,305$, and further:

$$f_1 \times \mu_1 = 1,305 \times 1,87 = 2,44.$$

If we summarize the values found and used in what precedes in the Hydrogen-Helium group, we get the following survey. (See Table A p. 292).

The value N placed on the lefthand of the sign for the element denotes the value of the "core charge", in connection with the frequencies of the so-called high frequency spectra of the elements (MOSELEY). N is also sometimes called the *atom number* of the elements concerned. We shall later on make a few more remarks on the ratio A (atomic weight): N .

The coefficients of direction γ refer to the values of D and D' determined experimentally, the quantities γ' have been calculated from formula (2).

We subjoin the values T_h, T_s, T_k etc. used, and also the above determined products $f_1 \times \mu_1$, which are a measure for the ratio $(v_1 - b_1) : v_1$ at the triple point.

¹⁾ From $b_k = RT_k \cdot 8p_k$ we, namely, calculate with $p_k = 62,43$ atm. $b_k = 276,8 \times 10^{-5}$. And from $a_k = RT_k \times b_k \times (27 : 8\lambda)$ we find further ($\lambda = 0,98$) $b_k = 131,8 \times 10^{-4}$, hence $\sqrt{a_k} = 11,5 \times 10^{-2}$. In the 5th series of the periodic system a value for b_k is expected somewhat greater than 275×10^{-5} , which would be valid for Supra-iodine (277×10^{-5} satisfies this demand), and for $\sqrt{a_k}$ a value $= \pm 11 \times 10^{-2}$, as was found among others for Hg (see I and II). Also this last expectation is again very nearly fulfilled.

We point out here, that when for *Neon* not the critical temperature estimated last by K. ONNES, viz. $\pm 45^\circ$ abs., but the somewhat higher value found before by K. O. and CROMMELIN (1911), viz. some degrees below 55° abs. — or the value found by RANKINE also in 1911, viz. $61^\circ,1$ abs., or the value found by RAMSAY and TRAVERS in 1900, viz. $< 68,1$ is taken, we find somewhat higher values for a_k and b_k than the before given values $b_k = 71 \times 10^{-5}$, $\sqrt{a_k} = 2,0 \times 10^{-2}$. If we assume $T_k = 60^\circ$ abs., $p_k = 29$ atm, then with $\lambda = 0,998$ b_k becomes $= 94,7 \times 10^{-5}$, $a_k = 7,035 \times 10^{-4}$, $\sqrt{a_k} = 2,65 \times 10^{-2}$. This latter value for $\sqrt{a_k}$ fits in already a good deal better with the system drawn up by us than the too low value 2,0, where a value 3 or slightly smaller than 3 was expected. With $T_k = 65^\circ$ abs. we should have found $b_k = 102,6 \times 10^{-5}$, $\sqrt{a_k} = 2,9 \times 10^{-2}$, which would be still more satisfactory.

	T_{tr}	T_S	T_k	p_k	D_k	$\frac{T_k}{T_S}$	$\mu_1 = \frac{T_k}{T_{tr}}$	$f_1 \times \mu_1$	Authors
H ₂	13,95	20,33	31,95	15,0	0,03025	1,57	2,29	1,91	K.O., Km., Dew.
He	±1	4,20	5,20	>2,26	0,066	1,24	5,20	5,27	K.O.
Ne	24,42	27,17	45?	29	—	1,66	1,84	1,83	K.O.; Cr.
Ar	83,79	87,25	150,65	48,0	0,531	1,73	1,80	2,04	Cr.; M., K.O., Cr.
Kr	104,1	121,4	210,6	54,3	—	1,73	2,02	2,46	R.; R., Tr.
X	133,1	166,2	289,7	58,2	1,154	1,74	2,18	2,71	R.; P., C., W.G.
Ni	202,1	211,1	377,6	62,4	—	1,79	1,87	2,44	Gr., R.

In the following paper the element groups of the Halogens, of the Oxygen and Nitrogen group, and also those of the Carbon group will be treated. For the Hydrogen-Helium group considered here we have not found anything special — for the following groups, however, we shall find the remarkable fact that everywhere where (specially for metals) the molecules of the elements consist only of one atom at T_k , the value of $\sqrt{a_k}$ becomes *much greater* than the normal one, calculated by us in I. These are only valid when two or more atoms are bound to each other in the molecule; so that the attraction cannot make itself *fully* felt in consequence of the mutually shadowing action. What we have found there ($\sqrt{a_k} = \text{resp. } 1, 3, 5, 7, 9, 11 \times 10^{-2}$) must be considered as a kind of **rest attraction**. If, namely, N₂ were entirely dissociated to N₁, the attraction found by us for N₂, viz. $\sqrt{a_k} = 2,9 \cdot 10^{-2}$, would at once rise to about **30** ($\times 10^{-2}$), hence to the *tenfold* value.

We shall even have an opportunity to ascertain, that where in compounds as TeCl₄ and TeCl₂, the shadowing action gradually decreases, the value of $\sqrt{a_k}$ will already increase. Thus $\sqrt{a_k}$ for TeCl₄ has the normal rest value 9. But for TeCl₂, $\sqrt{a_k}$ will already have risen to the value 13. The *non-saturate valencies*, therefore, already make their influence felt. If, however, also the last chlorine atoms have been removed, the attraction of the Tellurium rises still more, and reaches the value 26.

We shall find back this remarkable phenomenon for all metals; the exceedingly high values of melting point, boiling point, and critical temperature for many metals are owing to the high values of $\sqrt{a_k}$ in consequence of the monatomic state, from which ensues that the *valence-attraction* can make itself felt freely towards the outside.

That for the Helium group, where the molecules also consist of only one atom, only the ordinary rest attraction asserts itself, and not the so much greater valence-attractions, is owing to this that the noble gases mentioned are *valenceless*.

Clarens, May 1916.

Physics. — “On the Fundamental Values of the Quantities b and \sqrt{a} for Different Elements, in Connection with the Periodic System. IV. The Elements of the Halogen- Oxygen- and Nitrogen Groups.” By Dr. J. J. VAN LAAR. (Communicated by Prof. H. A. LORENTZ.)

(Communicated in the meeting of June 24, 1916).

I. The Halogen Group.

After the treatment of the valenceless eighth group of the periodic system, i.e. of the group of the noble gases (to which we have added the hydrogen for convenience, sake)¹⁾, we shall now discuss the seventh group, that of the Halogens. We remind the reader that our chief aim is now to determine the values of $\sqrt{a_k}$ of the *elements themselves*, independent of the values calculated before in I and II²⁾ from their *compounds*.

a. Fluor. The critical temperature is unknown; I find somewhere stated $-170^\circ \text{C.} = 103^\circ \text{abs.}$, but this cannot possibly be true, as the boiling point temperature lies already at $-187^\circ \text{C.} = 86^\circ \text{abs.}$ according to MOISSAN and DEWAR (1903). Now for the Halogens the ratio $T_k : T_b$ (Cf. the table in II on p. 18) is resp. 1,72 for I_2 , 1,73 for Br_2 , and 1,75 for Cl_2 . If, therefore, for F_2 we also assume 1,75 for it, T_k would become $=151^\circ \text{abs.}$ To this corresponds $2\gamma = 1 + 0,038\sqrt{151} = 1,467$, hence $\gamma = 0,733$. If, therefore, the triple point temperature lies at $-223^\circ \text{C.} = 50^\circ \text{abs.}$ (MOISSAN and DEWAR, 1903)³⁾, then $m_1 = 50 : 151 = 0,331$, and the factor $f_1 = b_k : v_1$ becomes:

$$f_1 = 1,467 \left[1 - \frac{0,733}{1,733} \times 0,331 \right] = 1,467(1 - 0,140) = 1,262.$$

Hence to find $b_k = 55 \cdot 10^{-5}$ for 1 Gr. atom Fluor, the atomic volume at the triple point must be $= (55 : 1,262) 10^{-5} = 43,6 \cdot 10^{-5}$. Now for -200°C. MOISSAN and DEWAR (1897) found $D = 1,14$,

¹⁾ See III, These Proc. p. 287.

²⁾ These Proc. of Jan. 29 and March 25, 1916; p. 1228 and 2.

³⁾ In the “Chemisch Jaarboekje” for 1915–1916, I find -233°C. given.

giving $v = 74,4 \cdot 10^{-5}$; this volume will probably be somewhat smaller at the triple point, which lies lower; not smaller, however, than about $63 \cdot 10^{-5}$, as is easy to calculate.

From all this it may be inferred that at present there is not much chance of reconciling the few data for Fluor.

If $f_1 = 1,262$ is correct, then

$$f_1 \mu_1 = 1,262 \times 3,020 = 3,81$$

would follow, with $\mu_1 = 151 : 50 = 3,020$.

b. Chlorine. With $D = 1,717$, $D' = 0$ at -100°C . (PELLATON. Thèse 1915, p. 31) we calculate from

$$2\gamma = \frac{(d + d') - 2}{1 - m} = \frac{T_k(D + D') - 2D_k}{D_k(T_k - T)}$$

for 2γ the value

$$2\gamma = \frac{417,1}{0,573} \cdot \frac{1,716 - 1,146}{417,1 - 173,1} = 1,700^1).$$

The values of T_k and D_k , and also the others, have been borrowed from PELLATON.

From the formula $2\gamma = 1 + 0,038 \sqrt{417,1}$ the somewhat greater value 1,776 would have been calculated for 2γ .

Now the triple point lies at $-101,5^\circ \text{C} = 171,06$ abs. (JOHNSON and Mc. INTOSH, 1909); hence from $(D_1 - D) : D_k = 2\gamma(m - m_1)$ we find:

$$D_1 = 1,717 + 0,573 \times 1,700(0,4150 - 0,114) = 1,721,$$

from which follows $A : D_1 = 20,61$, $v_1 = 91,96 \cdot 10^{-5}$.

We find further for the factor f_1 :

$$f_1 = 1,700 \left[1 - \frac{0,85}{1,85} \times 0,411 \right] = 1,7(1 - 0,189) = 1,379.$$

From this is calculated $b_k = 91,96 \cdot 10^{-5} \times 1,379 = 126,8 \cdot 10^{-5}$, while from T_k and p_k (values of PELLATON) 125,5 is directly calculated (for 1 atom Cl).

From $\gamma = 0,85$ would follow $v = v_k : b_k = (\gamma + 1) : \gamma = 2,176$. As $D_k = 0,573$, we have $v_k = 35,46 : 0,573 : 22412 = 276,1 \cdot 10^{-5}$ for 1 atom. Hence b_k would be $= (276,1 \cdot 2,176) 10^{-5} = 126,9 \cdot 10^{-5}$, quite identical to the value found just now by the aid of γ from the so distant value of D_1 at the triple point.

As $\mu_1 = T_k : T_v = 2,436$, we get:

$$f_1 \mu_1 = 1,379 \times 2,436 = 3,36.$$

¹⁾ Between 0°C . and T_k with $D = 1,4678$, $D' = 0,0128$ we should have found the slightly lower value 1,692.

c. **Bromine.** As for want of data γ cannot be directly calculated, we shall determine the approximated value from our formula. From $T_k = 575,3$ (NADEJDINE, 1885) follows $2\gamma = 1,912$, $\gamma = 0,956$. Hence we find for f_1 :

$$f_1 = 1,912 \left[1 - \frac{0,956}{1,956} \times 0,462 \right] = 1,912 (1 - 0,226) = 1,480.$$

From $T_b = -7^\circ,3$ C. = $265^\circ,8$ abs. (v. D. PLAATS, 1886; the latter found for the boiling point $63^\circ,05$ C., while RAMSAY and YOUNG later found for it $58^\circ,7$ C.) follows namely $m_1 = 0,462$.

As the density at 0° C. is found = $3,187$ (v. D. PLAATS), it will be at the triple point:

$$D_1 = 3,187 + 1,06 \times 1,912 (0,4747 - 0,4620) = 3,213.$$

In this the calculated value $1,06$ has been taken for D_k ¹⁾. (NADEJDINE found $1,18$).

As $v_1 = 111,0 \cdot 10^{-5}$, we find further from f_1 $b_k = 111,0 \cdot 10^{-5} \times 1,480 = 164,3 \cdot 10^{-5}$, while $165 \cdot 10^{-5}$ has been found from compounds.

As $\mu_1 = 575,3 : 265,8 = 2,164$, we get:

$$f_1 \mu_1 = 1,480 \times 2,164 = 3,20.$$

d. **Iodine.** Here too we must determine γ from our approximate formula. With $T_k = 785^\circ,1$ abs. we then find $2\gamma = 2,065$, $\gamma = 1,032$.

The density at 0° C. is according to GAY LUSSAC $4,948$. But this value cannot possibly be correct, as DEWAR found the *smaller* value $4,894$ at -188° .

If in approximation we assume continuity in the thermal expansion of the solid and liquid state — i.e. if we assume that the expansivity of solid iodine (about which I have not been able to find any values recorded) is the same as that of liquid iodine at low temperatures, where the vapour density can be neglected, so that the straight diameter can be thought prolonged unchanged as far as in the solid phase — then D_1 at the triple point $113^\circ,7$ C. = $386^\circ,8$ abs. (LADENBURG, 1902; he found for the boiling point $183^\circ,05$ C.) can be approximately determined from

¹⁾ This value can be calculated in two ways. First of all from $v_k = r b_k = b_k \times (\gamma + 1) : \gamma$. This gives with $b_k = 165 \cdot 10^{-5}$, $\gamma = 0,956$ for v_k the value $165 \times 2,046 \times 10^{-5} = 337,6 \cdot 10^{-5}$. Hence D_k becomes = $79,92 : 337,6 : 0,22412 = 1,056$.

Then from the formula $\frac{1}{2} D : D_k = 1 + \gamma(1 - m)$, when the vapour density D' can be neglected. With $D = 3,187$ at 0° C. ($m = 0,475$) this gives the value $1,5935 : 1,502 = 1,061$ for D_k .

$$D_1 = 4,894 + 1,275 \times 2,065 (0,1083 - 0,4927) = 3,882,$$

because at $-188^\circ \text{C.} = 85^\circ \text{abs.}$ the value of m is $= 0,1083, m_1 = 0,4927$ being calculated. For D_k we have assumed the value $1,275^1$ ($1,34$ is given somewhere as "calculated"). For v_1 we therefore find $v_1 = 145,9 \cdot 10^{-5}$.

For the factor f_1 we calculate further:

$$f_1 = 2,065 \left[1 - \frac{1,032}{2,032} \times 0,493 \right] = 2,065 (1 - 0,250) = 1,548.$$

Because of this b_k becomes $= 145,9 \cdot 10^{-5} \times 1,548 = 225,9 \cdot 10^{-5}$, $220 \cdot 10^{-5}$ being found from the compounds. The value for D_1 calculated only by approximation is therefore, probably, slightly too low.

At last we calculate for the product $f_1 \mu_1$:

$$f_1 \mu_1 = 1,548 \times 2,030 = 3,14$$

These products are therefore not constant for the Halogen group either. From $3,8$ (?) with F_2 $f_1 \mu_1$ steadily decreases to $3,4$ with Cl_2 , $3,2$ for Br_2 , and $3,14$ for I_2 . Yet (leaving F_2 out of consideration) the decrease is not very great, so that we may possibly assume a middle value of $3,2$.

In the following table the fundamental values of the group have again been combined. The values of v_1 and b_k always refer to 1 atom.

TABLE B₁.

N	A	A/N	D_1	A/D_1	$10^5 v_1 = \text{id.}:$ 0,22412	γ	γ'	m_1	f_1	$10^5 b_k$ calculated	$10^5 b_k$ found
9 F_2	19,0	2,11	—	—	—	—	0,733	0,331	1,262	—	(55)
17 Cl_2	35,46	2,09	1,721	20,61	91,96	0,850	0,888	0,411	1,379	127	125,5 (115)
35 Br_2	79,92	2,28	3,213	24,87	111,0	—	0,956	0,462	1,480	164	(165)
53 I_2	126,92	2,39	3,882	32,69	145,9	—	1,032	0,493	1,548	226	(220)
85 —	± 216	2,54	—	—	—	—	—	—	—	—	—

The values of b_k "found" placed between brackets could not be determined directly from T_k and μ , as p_k is unknown; they are the values which were formerly calculated from the compounds

¹) With $b_k = 220 \cdot 10^{-5}$, $\gamma = 1,032$ we really find $v_k = 220 \times 1,969 \times 10^{-5}$, hence $D_k = 126,92 : (220 \times 1,969 \times 0,22412) = 1,307$. With $D = 4,894$ at -188°C. ($m = 0,083$) the value $2,447 : 1,920 = 1,275$ is found for D_k . We have preferred this latter value.

(see I). The value 125,5 for $10^5 b_k$ for chlorine has been calculated from PELLATON's critical data, 113 following from those of DEWAR.

When p_k is unknown the values of $\sqrt{a_k}$ for 1 atom can be calculated from the formula $RT_k = \frac{27}{2} \lambda \cdot n_k \cdot (a_{k_1} : b_{k_1})$, in which n_k represents the number of atoms in the molecule at T_k . For if to distinguish between a_k and b_k (which now refer to the whole molecule), we denote the values referring to 1 atom by a_{k_1} and b_{k_1} , evidently $a_k = n_k^2 \cdot a_{k_1}$ and $b_k = n_k \cdot b_{k_1}$. If in the formula mentioned the factor λ is in the neighbourhood of $\frac{27}{2}$ for substances with comparatively high critical temperature (when namely $\gamma = 1$), then, as we already saw before, this formula reduces to $T_k = 78,03 n_k \cdot (a_{k_1} : b_{k_1})$. But as soon as γ differs considerably from unity, it is better to use the general formula, in which $\lambda = \frac{27}{8\gamma-1} \left(\frac{\gamma}{\gamma+1} \right)^2$.

Thus we calculate for a_{k_1} the value $5,47 \cdot 10^{-4}$, hence $\sqrt{a_{k_1}} = 2,34 \cdot 10^{-2}$, for F_2 with $n_k = 2$, $T_k = 151^\circ$ abs., $b_{k_1} = 55 \cdot 10^{-5}$. This value is considerably lower than that found for compounds, namely about $2,9 \cdot 10^{-2}$.

For Cl_2 we calculate directly the value $\sqrt{a_{k_1}} = 5,75 \cdot 10^{-2}$ from T_k and p_k , when we use the critical data of PELLATON, but $5,43 \cdot 10^{-2}$ with those of DEWAR. In compounds on an average $5,4 \cdot 10^{-2}$ was found.

For Br_2 and I we find in the same way for a_{k_1} resp. the values $60,4 \cdot 10^{-4}$ and $111,2 \cdot 10^{-4}$, when namely $n_k = 2$ is taken. This would give $\sqrt{a_{k_1}} = 7,77 \cdot 10^{-2}$, resp. $10,55 \cdot 10^{-2}$. But these values are *much greater* than the normal values 7, resp. 9 found for compounds, so that from this we can draw the conclusion that in connection with what we shall find later concerning the so much greater attraction for the *isolated* atoms, which for the present we may put at about $30 \cdot 10^{-2}$ — the two elements Br_2 and I_2 at the critical temperature have already been dissociated for a small part into atoms Br_1 and I_1), where therefore the *full* attraction of these atoms begins to make itself felt. But on account of this n_k will no longer be $= 2$, hence we should reconsider our calculation of $\sqrt{a_{k_1}}$.

If we namely assume that the above formula for RT_k continues to hold by approximation, when instead of with a *simple* substance we have to do with a *mixture* of two substances (e.g. I_2 and I),²⁾

¹⁾ As far as I_2 is concerned, this dissociation at 512° C. cannot astonish us, as it is known that the dissociation $I_2 \rightarrow 2 I_1$ is already *complete* at about 1500° C.

²⁾ In reality (cf. *Arch. Teyler* 1808 and *These Proc.* of May 30 1914, p 601) T_k will not depend linearly on the degree of association n_k , but it can deviate from it $6\frac{1}{2}\%$ as a maximum (for $x = \frac{2}{3}$). If, however, x is slight, e.g. 0,1, the deviation is so insignificant that it may be neglected.

then with $n_k = 2 : (1 + x)$, in which n_k now represents the so-called degree of association of the atoms Br and I, and x the degree of dissociation of the molecules Br_2 , resp. I_2 , we get:

$$a_{k_1} = \frac{RT_k \cdot b_{k_1}}{s/27 \lambda} : \frac{2}{1+x} \text{ instead of } a'_{k_1} = \frac{RT_k \cdot b_{k_1}}{s/27 \lambda} : 2,$$

so that evidently we have still to multiply the values found above of $\sqrt{a_{k_1}}$ by $\sqrt{1+x}$.

If now the attractions $\sqrt{a_{k_1}}$ for the atoms differ for the cases that they are either united in a molecule to e.g. I_2 , or occur freely as I_1 , evidently:

$$\sqrt{a_{k_1}} = (1-x) \sqrt{(a_{k_1})_2} + x \sqrt{(a_{k_1})_1},$$

so that at last we have for the calculation of the degree of dissociation x :

$$\sqrt{a'_{k_1}} \cdot \sqrt{1+x} = (1-x) \sqrt{(a_{k_1})_2} + x \sqrt{(a_{k_1})_1},$$

in which $\sqrt{a'_{k_1}}$ denotes the value calculated above with $n_k = 2$. If now for $(a_{k_1})_1$ we assume the preliminary value $30 \cdot 10^{-2}$ (see above), we have for Br_2 :

$$7.8 \sqrt{1+x} = 6.9(1-x) + 30x,$$

as before $\sqrt{(a_{k_1})_2} = 6.9 \cdot 10^{-2}$ was found for the compounds (see 1). For x we then find about $1/21 = 0.048$, so that $\sqrt{1+x}$ would become $= 1.024$.

For the real value of $\sqrt{a_{k_1}}$ we thus find $7.77 \cdot 10^{-2} \times 1.024 = 7.96 \cdot 10^{-2}$, for which we may therefore write $8.0 \cdot 10^{-2}$.

In the same way we shall find for I_2 , with $\sqrt{(a_{k_1})_2} = 8.8 \cdot 10^{-2}$:

$$10.5 \sqrt{1+x} = 8.8(1-x) + 30x,$$

from which $x = 0.104$, $\sqrt{1+x} = 1.051$ follows, so that the real value of $\sqrt{a_{k_1}}$ for I_2 becomes $= 10.55 \cdot 10^{-2} \times 1.051 = 11.06 \cdot 10^{-2} = 11.1 \cdot 10^{-2}$.

The values found are joined with some supplementary values in the following table.

TABLE B₂.

	T_{tr}	T_s	T_k	p_k	D_k	$\frac{T_k}{T_s}$	$\nu_1 = \frac{T_k}{T_{tr}}$	$f_1 \nu_1$	$10^2 \sqrt{a_k}$ calculated	$10^2 \sqrt{a_k}$ in comp.	Diss. degr. x
F_2	50	86	(151)	—	—	(1,75)	(3,02)	(3,81)	(2,34)	2,9?	—
Cl_2	171,6	238,6	417,1	76,1	0,573	1,75	2,44	3,36	5,75	5,4	—
Br_2	265,8	331,8	575,3	—	(1,06)	1,73	2,16	3,20	8,0	6,9	0,05
I_2	386,8	456,1	785,1	—	(1,29)	1,72	2,03	3,14	11,0	8,8	0,10

In consequence of the *provisional* assumption that the attraction of the isolated atoms amounts here to about $30 \cdot 10^{-2}$ (which is not quite certain, as no experiments have as yet taken place with atomic Br and I), the values of $\sqrt{a_k}$ and x calculated for Br₂ and I₂, are accurate only in approximation.

II. The oxygen group.

a. Oxygen. For γ 0,813 has been experimentally found (MATHIAS and KAMERLINGH ONNES)¹⁾. From this follows for the density at the triple point 54°,7 abs. (K. O. and CROMMELIN), where $m_1 = 0,3546$:

$$D_1 = 1,2747 + 0,4299 \times 1,626 (0,4065 - 0,3546) = 1,311.$$

At 62°,7 the density D ($m = 0,4065$) is namely = 1,2746, D' being = 0,0001 (M. and K. O.). Further $D_k = 0,4299$ (Ibid), $T_k = 154°,25$ abs. (K. O., DORSMAN and HOLST, 1915, who also determined ρ_k ; while K. O. and BRAAK determined T_s).

We find for the factor f_1' :

$$f_1 = 1,626 \left[1 - \frac{0,813}{1,818} \times 0,3546 \right] = 1,626 (1 - 0,259) = 1,367.$$

Hence $b_k = 74,4 \cdot 10^{-5}$ follows from $v_1 = 54,45 \cdot 10^{-5}$, whereas $71 \cdot 10^{-5}$ has been found directly from T_k and ρ_k .

Now the product $f_1 \mu_1$ becomes:

$$f_1 \mu_1 = 1,367 \times 2,820 = 3,85.$$

b. Sulphur. In 1888 VICENTINI and OMODEI found the value 1,8114 for the density at the melting point of the metastable rhombic sulphur (112°,8 C.). The melting point of monoclinic sulphur lying at 119°,25 (just as the preceding value given by KRUYT, Thesis for the Doctorate 1908; or at 118°,95 given by WIGAND, 1911), we can by approximation determine the density of monoclinic sulphur at the melting point by the aid of the cubic coefficient of expansion of liquid sulphur (0,000458 between 126° and 167° C. according to KOPP). We then find 1,8063.

For the coefficient of direction of the straight diameter we calculate from $T_k = \pm 700^\circ$ C. = 973° abs. the approximate value $2\gamma = 2,185$, $\gamma = 1,093$.

This gives for the factor f_1 ($m_1 = 0,403$):

$$f_1 = 2,185 \left[1 - \frac{1,093}{2,093} \times 0,403 \right] = 2,185 (1 - 0,210) = 1,725.$$

As $v_1 = 79,24 \cdot 10^{-5}$, b_k becomes = $136,7 \cdot 10^{-5}$, $125 \cdot 10^{-5}$ having

¹⁾ With $T_k = 154°,25$ the formula for 2γ would have yielded the value 1,4720, from which $\gamma = 0,736$ would follow, i.e. much smaller than M. and K. O. found.

been found from compounds. Hence the value used for γ is possibly somewhat too great.

As $\mu_1 = 973 \cdot 392 = 2,482$, we get

$$f_1 \mu_1 = 1,725 \times 2,482 = 4,28$$

With regard to the value of $\sqrt{a_k}$ it may be stated that this value can only be calculated with any certainty from T_k , when the molecular state is known there. Now we only know (see PRELNER and SCHUPP, Z. f. ph. Ch. 68, p. 129) that sulphur vapour consists of molecules S_8 , S_6 , S_2 , and S_1 at different temperatures; between 500° and 800° C. chiefly of S_6 and S_2 -molecules [At lower temperatures more and more S_8 -molecules occur, and only at very high temperatures — according to v. WARTENBERG (Z. f. ph. Ch. 77, p. 66) not before about 2000° C. — atoms S_1]. From the formula for T_k follows with $b_{k_1} = 125 \cdot 10^{-5}$

$$a_{k_1} = 973 \times 125 \cdot 10^{-5} : 780 n_k = 158,0 \cdot 10^{-4} : n_k,$$

because θ (the correction factor for λ , about which we spoke above,

and which is evidently $= \frac{28}{8\gamma - 1} \left(\frac{\gamma}{\gamma + 1} \right)^2$) is $= 0,9866$. As now $6,3 \cdot 10^{-2}$

has been found for $\sqrt{a_{k_1}}$ from compounds, and a_{k_1} therefore becomes $= 39,7 \cdot 10^{-4}$, n_k would become $= 3,98$ — which therefore practically means that sulphur at the critical temperature would on an average consist almost entirely of molecules S_4 .¹⁾ If however $\sqrt{a_{k_1}}$ should be $= 5 \cdot 10^{-2}$, n_k would become $= 6,32$, and chiefly S_6 -molecules would be present.

In order to find out something about the attraction of sulphur in compounds, we have examined also S_2Cl_2 , $SOCl_2$, and SO_2Cl_2 . We find successively:

	T_k	$10^5 b_k$	$10^4 a_k$	$10^2 \sqrt{a_k}$	
$S_2 Cl_2$	664,4?	$2 \times 125 + 2 \times 115 = 480$	408,7	20,2	S = $4,7 \cdot 10^{-2}$
$SO Cl_2$	569,9	$125 + 70 + 230 = 425$	310,4	17,6	" 4,1 "
$SO_2 Cl_2$	549,7	$125 + 140 + 230 = 495$	348,7	18,7	" 2,5 "

If for Cl we take the value $5,4 \cdot 10^{-2}$ and for O the value $2,7 \cdot 10^{-2}$, we find for S the above given values, which are all smaller than the fundamental value 6,3 found for H_2S and SO_2 . In the two first compounds the attraction is, however, not far from the normal fundamental value 5, it being about half this value for the last compound.

¹⁾ I.e. such a mixture of S_6 and S_2 molecules that on an average n_k is $= 4$.

c. **Selenium.** As $T_k = 973^{\circ},1$ abs. and $T^* = 717^{\circ},6$ abs. for sulphur [444^o,5b C. was namely found for T_s by WAIDNER and BURGESS (1910), HOLBORN and HENNING (1911), DAY and SOSMAN (1912)], the ratio $T_k : T_s$ is = 1,36 (it was = 1,71 for O₂). If in approximation we assume for selenium for $T_k : T_s$ the same value as for sulphur, we find the value 1310° abs. for T_k from $T_s = 688^{\circ}$ C. = = 961° abs. [PREUNER and BROCKMÖLLER, Z. f. ph. Ch. 81, p. 146 (1912). Already in 1902 BERTHELOT gave 690° C.]. From this the value 2,375 would follow for 2γ , hence $\gamma = 1,19$. Hence

$$f_1 = 2,375 \left[1 - \frac{1,19}{2,19} \times 0,377 \right] = 2,375 (1 - 0,205) = 1,889.$$

For the density of grey Selenium 4,8 or 4,5 was found by SAUNDERS (1900)¹⁾ Further SPRING found for the (linear) coefficient of expansion between 0° and 100° the value 0,00006604. From this we calculate for the density at the melting point 220°,2 C. = = 493°,3 abs. (BERGER, 1914) $D_1 = 4,61$ or 4,32, giving $v_1 = 76,7$ or $81,8 \cdot 10^{-5}$. From this follows therefore with the just found value of f_1 for b_k the value 145 or 155 10^{-5} , while $180 \cdot 10^{-5}$ is expected.²⁾ (RUDORF's value for D_1 would have given $b_k = 163 \cdot 10^{-5}$).

If $T_k = 1310^{\circ}$ abs.³⁾, then $\mu_1 = 2,655$, and hence

$$f_1 \mu_1 = 1,889 \times 2,655 = 5,02.$$

For the attraction of Selenium itself, we find at last with $b_k = 180 \cdot 10^{-5}$:

$$a_{k_1} = 1310 \times 180 \cdot 10^{-5} : 78 \theta n_k = 311,7 \cdot 10^{-4} : n_k,$$

as $\theta = 0,9694$. As the normal value of $\sqrt{a_{k_1}}$ is = 7,1 $\cdot 10^{-2}$ for Se, and therefore $a_{k_1} = 50,4 \cdot 10^{-4}$, the value 6,18 would follow from this for n_k , so that at the critical temperature Selenium would on an average be = \pm Se₆. But according PREUNER and BROCKMÖLLER's researches (p. 139 loc. cit.) the dissociation of Se₆ molecules into Se₂-molecules would already be complete at 850° C., so that at $T_k =$ about 1040° C. the molecular formula cannot possibly be Se₆. Even if we take 160 or 170 atm. for the critical pressure, the degree of dissociation would be about = 1 at this temperature. If we assume therefore $n_k = 2 : (1+x)$, we find $a_{k_1} = 155,9 \cdot 10^{-4} \times (1+x)$, or $\sqrt{a_{k_1}} = 12,49 \cdot 10^{-2} \times \sqrt{(1+x)}$.

1) In his well-known book on the periodic system (1904) RUDORF gives for the density the still lower value 4,26.

2) From H₂Se (see I) Se = 138 $\cdot 10^{-5}$ is indeed calculated, but this value is evidently much too low.

3) From the vapour-pressure determinations of PREUNER and BROCKMÖLLER (loc. cit. p. 146) between 390° and 710° C. we can hardly conclude with any accuracy to the values of T_k and p_k , on account of the great variability of the molecular condition between these two temperatures.

But as 12,5 is much greater than the normal value 7,1 for compounds, decomposition of the Se_2 -molecules into simple Se, atoms with greater attraction must necessarily have set in at T_k already. If x is the degree of dissociation of the Se_2 -molecules, n_k will be $= 2 : (1+x)$, and 12,5 must still be multiplied by $\sqrt{1+x}$. On the assumption that also for Selenium the attraction of the atoms is about $30 \cdot 10^{-2}$, we have therefore for the determination of x .

$$12,5 \sqrt{1+x} = 7,1 (1-x) + 30 x,$$

from which $x=0,315$ follows, so that $\sqrt{a_{k_1}} = 12,49 \cdot 10^{-2} \times 1,147 = 14,3 \cdot 10^{-2}$, as $\sqrt{1+x} = 1,147$.

In contradiction with v. WARTENBERG's statement [Z. f. anorg. Ch. 56, p. 320 (1907)], according to whom a perceptible decomposition into Se, atoms would not set in before 2000°C ., we find already a very pronounced dissociation at a little above 1000°C .

Accordingly the above found value of a_k leaves us the alternative $n_k = 6,2$ or $n_k = 2 : 1,315 = 1,5$. According to what has been said the latter value is the more probable one.

d. Tellurium. In 1880 ST. CLAIRE DEVILLE found for the boiling point $1390^\circ \text{C} = 1663^\circ \text{abs}$. Hence with the factor 1,36 (see for Selenium) T_k would become $= 2260^\circ$. For 2γ we calculate from this in approximation by means of our formula the value $2\gamma = 2,807$, hence $\gamma = 1,403$. Hence

$$f_1 = 2,807 \left[1 - \frac{1,403}{2,403} \times 0,321 \right] = 2,807 (1 - 0,1875) = 2,281.$$

The value of m_1 has been calculated from the melting-point temperature determined by JAEGER (1909), viz. $452^\circ,5 \text{C} = 725^\circ,6 \text{abs}$.

KAHLBAUM (1902) gives 6,235 for the density at the ordinary temperature¹). SPRING found 0,00003687 for the (linear) coefficient of expansion between 0° and 100° , which — extrapolated to 450°C . — would render the density at the melting-point about 5,94. From this we calculate $v_1 = 95,7 \cdot 10^{-5}$. With $f_1 = 2,28$ the value $218 \cdot 10^{-5}$ is then found from this for b_k , whereas $235 \cdot 10^{-5}$ was expected. Possibly the value of D_1 is taken too high, or that for f_1 and γ (through T_k) too low, just as for Selenium.

With $\mu_1 = 3,115$ we get

$$f_1 \mu_1 = 2,281 \times 3,115 = 7,10.$$

At last the value of $\sqrt{a_{k_1}}$. With $b_k = 235 \cdot 10^{-5}$ we calculate from T_k :

$$a_{k_1} = 2260 \times 235 \cdot 10^{-5} : 78 \theta n_k = 729,3 \cdot 10^{-4} : n_k,$$

¹) LENHER and MORGAN (1900) give 6,199; KRÖNER (Diss.) values which vary between 6,27 and 6,10.

as $\theta = 0,9333$. With the normal value $9 \cdot 10^{-2}$ for the attraction for Te about $n_k = 15$ would have been found, which is of course impossible. If we assume that also here for T_k the dissociation to Te_2 is complete, and that the Te_2 -molecules are still further dissociated to Te_1 , then $n_k = 2:(1+x)$, and a_{k_1} becomes $= 364,6 \cdot 10^{-4} \times (1+x)$, hence $\sqrt{a_{k_1}} = 19,10 \cdot 10^{-2} \times \sqrt{1+x}$ — hence again much greater than the normal value 9, so that there are really isolated atoms Te_1 present at T_k .

The value of the degree of dissociation x is calculated from

$$19,1 \sqrt{1+x} = 9(1-x) + 30x,$$

giving $x = 0,787$. Accordingly at the critical temperature Tellurium is already dissociated to separate atoms at least for the greater part. If the atomic attraction should then be greater than $30 \cdot 10^{-2}$, e.g. $35 \cdot 10^{-2}$, x would be somewhat smaller, viz. 0,576. With $x = 0,79$ $\sqrt{a_{k_1}}$ becomes $= 19,10 \cdot 10^{-2} \times 1,337 = 25,5 \cdot 10^{-2}$, as $\sqrt{1+x} = 1,337$.

Just as for sulphur we have investigated the value of the molecular attraction of a few more compounds, viz. $TeCl_4$ and $TeCl_2$. We find for this what follows.

	T_k	$10^5 b_k$	$10^4 a_k$	$10^2 \sqrt{a_k}$	
$TeCl_4$	1099	$235 + 4 \times 115 = 695$	979,2	31,3	$Te = 9,7 \cdot 10^{-2}$
$TeCl_2$	955	$235 + 2 \times 115 = 465$	569,1	23,9	" 13,1 "

The critical temperatures have been calculated from the known boilingpoint temperatures, viz. 687° and 597° abs. by multiplication by 1,6. For $TeCl_4$ the normal value $9 \cdot 10^{-2}$ seems to be found. For $TeCl_2$, however, the increased atomic attraction makes itself already felt in consequence of the released valencies.

The different fundamental values have again been joined in the following table.

TABLE C₁.

N	A	A/N	D_1	A/D_1	$10^5 v_1 = \text{id.}: 0,22412$	γ	γ'	m_1	f_1	$10^5 b_k$ calculated	$10^5 b_k$ found
8 O ₂	16,00	2,00	1,311	12,20	54,45	0,813	0,736	0,355	1,367	74,4	71 (7)
16 S	32,06	2,00	1,806	17,76	79,24	—	1,09	0,403	1,725	137	(125)
34 Se	79,2	2,33	4,3	18,3	81,8	—	1,19	0,377	1,889	155	(180)
52 Te	127,5	2,45	5,9	21,5	95,7	—	1,40	0,321	2,281	218	(235)
84 Po	± 215	2,56	—	—	—	—	—	—	—	—	—

20

Proceedings Royal Acad. Amsterdam. Vol. XIX.

The value of b_k found for oxygen has been immediately calculated from T_k and p_k (see I); the other values (placed between brackets) are those which have been found for the compounds. We have further still:

TABLE C₂.

	T_{tr}	T_s	T_k	p_k	D_k	$\frac{T_k}{T_s}$	$\nu_1 = \frac{T_k}{T_{tr}}$	$f_1 \nu_1$	$10^2 \sqrt{ak}$ calculated	$10^2 \sqrt{a_k}$ in comp.	Diss. degr. x
O ₂	54,7	90,10	154,25	49,71	0,4299	1,71	2,82	3,85	2,6	2,7	0
S ₈	392,0	717,6	973	—	—	1,36	2,48	4,28	6,3 (S ₄) 5,1 (S ₆)	6,3	0
Se ₂	493,3	961	(1310)	—	—	(1,36)	2,63	4,97	14,3	7,1	0,32
Te ₂	725,6	1663	(2260)	—	—	(1,36)	3,11	7,10	25,5	9	0,79

The value $2,6 \cdot 10^{-2}$ for O₂ has been directly calculated from T_k and p_k (see I).

As for the values of $f_1 \nu_1$, they ascend from about 4 to 7. But in this it is noteworthy that the derivation of the relation $f_1 \nu_1 = \text{constant}$ from the hypothetical assumption that at the triple point $(v_1 - b_1) : v_1$ should be constant, is only valid for the case that the molecular state at the triple point and the critical point is the same. This now is certainly not the case for Sulphur, Selenium and Tellurium. In the following paragraph we shall treat this point (for Phosphorus) more at length.

For the first time we meet with an element (Tellurium) in this group which at the critical temperature has already been greatly dissociated to *atoms*, and which accordingly begins to exhibit a metallic character. In the following groups of the periodic system, which we shall discuss now, this phenomenon stands out more and more clearly.

III. The Nitrogen group.

a. Nitrogen. The value of γ is known here from the researches of MATHIAS, K. ONNES and CROMMELIN, who found for this 0,793¹⁾. From this we can calculate the density D_1 at the triple point (63°,06° abs. according to KEESOM and K. ONNES; CROMMELIN found 78° abs. for the boiling point). As for 64°,73° abs. $D = 0,8622$, $D' = 0,0009$ (M., K.O., Cr.), we get with $\gamma = 0,3110$ (the same authors) and

¹⁾ We calculate from our approximate formula $\gamma = 0,713$, therefore just as for O₂ smaller than the experimentally found value.

$T_k = 125^{\circ},96$ abs. (K.O., DORSMAN and HOLST, who also determined the critical pressure):

$$D_1 = 0,8631 + 0,3110 \times 1,586 (0,5193 - 0,5006) = 0,8697.$$

From this follows $A : D_1 = 16,11$, hence $v_1 = 71,88 \cdot 10^{-5}$.

For the factor $f_1 = b_k : v_1$ we find further:

$$f_1 = 1,586 \left[1 - \frac{0,793}{1,793} \times 0,5006 \right] = 1,586 (1 - 0,221) = 1,235.$$

We therefore calculate $88,8 \cdot 10^{-5}$ for b_k , while $86 \cdot 10^{-5}$ was found directly from T_k and p_k .

Finally we have for the product $f_1 \mu_1$:

$$f_1 \mu_1 = 1,235 \times 1,998 = 2,47.$$

b. Phosphorus. From the approximate formula the value 2,182 follows for 2γ from $T_k = 968^{\circ}$ abs., so that γ becomes = 1,091. With $T_u = 44^{\circ},1$ C. = 317,2 abs. for the *yellow* phosphorus (SMITS and DE LEEUW, 1911) we find therefore (m_1 being = 0,3277):

$$f_1 = 2,182 \left[1 - \frac{1,091}{2,091} \times 0,3277 \right] = 2,182 (1 - 0,171) = 1,809.$$

All this refers to the *yellow* (white) phosphorus, which according to SMITS c. s. is a metastable continuation of the liquid phosphorus below $589^{\circ},5$ (the melting point of the red phosphorus). As this latter point lies too high for the calculation (the vapour pressure is there already 43,1 atm.), and the density D_1 is perfectly unknown there, we have chosen the melting point of the yellow phosphorus as starting point.

For the density of the yellow phosphorus 1,82 has been found at 0° C. (JOLIBOIS, 1910); hence $D_1 = 1,79$ will be found at 44° with the (linear) coefficient of expansion 0,0001278 (between 16° and 42° C. according to KOPP). Therefore $A : D_1$ becomes = 17,34 and $v_1 = 77,37 \cdot 10^{-5}$. We find therefore $140,0 \cdot 10^{-5}$ for b_k , while the value $134 \cdot 10^{-5}$ has been found from T_k and p_k , and the theoretical value amounts to $140 \cdot 10^{-5}$.

The product $f_1 \mu_1$ becomes for the yellow phosphorus:

$$f_1 \mu_1 = 1,809 \times 3,053 = 5,52.$$

For the *red* phosphorus, where $\mu_1 = 968,1 : 862,6 = 1,122$ and $m_1 = 0,8913$, therefore $f_1 = 2,182 (1 - 0,465) = 1,167$, $f_1 \mu_1$ becomes:

$$f_1 \mu_1 = 1,167 \times 1,122 = 1,31$$

There exists therefore a great difference in these values for the two phosphorus modifications, which is chiefly caused by the different molecular state at the two triple points. Really a higher degree of polymerisation is assigned to the red phosphorus than to the yellow

phosphorus (P_4) — probably considerably higher than P_8 (SCHENK).

In III we saw that the ratio $(v_1 - b_1) : v_1$, is only dependent on the product $f_1 \mu_1$. But — we observed it already above — in this it was supposed that the molecular state at T_l and T_h is the same. If this is no longer the case, the relation derived there, is slightly modified. If the quantities a , b , and v refer to atom quantities, then at the triple point the relation

$$\frac{a_1}{v_1^2} (v_1 - b_1) = \frac{1}{n_1} RT_1$$

holds (ρ being neglected), when n_1 represents the number of atoms in the molecule. But for T_k the relation

$$RT_k = \frac{2}{7} \frac{a_k}{b_k} \times n_k$$

holds with great approximation (a_k and b_k refer again to 1 atom, the factor $2/7$ holds for comparatively high critical temperatures), because then again the molecular attraction = $n_k^2 \times a_k$, and the molecular volume = $n \times b_k$. Hence

$$\frac{a_1}{a_k} \times \frac{7 RT_k}{2} \frac{b_k}{n_k} \frac{v_1 - b_1}{v_1^2} = \frac{RT_1}{n_1},$$

or

$$\frac{v_1 - b_1}{v_1} = \frac{2 a_k n_k v_1 T_1}{7 a_1 n_1 b_k T_k}.$$

Now $T_k : T_1 = \mu_1$, $b_k : v_1 = f_1$, hence we get :

$$\frac{v_1 - b_1}{v_1} = \frac{2 a_k n_k}{7 a_1 n_1 f_1 \mu_1} = \frac{2}{7} \times \frac{1}{\varphi},$$

so that now not $f_1 \mu_1$, but

$$f_1 \mu_1 \times \frac{a_1 n_1}{a_k n_k} = \varphi \dots \dots \dots (1)$$

becomes a measure for the ratio $(v_1 - b_1) : v_1$ at the triple point.

As for the two phosphorus modifications the atomic attractions a_1 and a'_1 will be the same at the triple point, the values of $f_1 \mu_1 \times n_1$ will here be decisive for the value of the ratio $(v_1 - b_1) : v_1$ in the two cases.

Now it is remarkable that 1,31 is about $1/4$ of 5,52 (in our above calculation the values of γ are put equal for the two modifications, which is certainly not quite true, so that the first value of $f_1 \mu_1$ will only be accurate by approximation). If therefore we assume the formula P_4 for the yellow phosphorus at the melting-point, then the formula P_{16} would hold for the red phosphorus at the melting point of this modification.

With regard to the critical temperature we saw above that phosphorus there answers pretty well to formula P_4 . For $b_k = 535 \cdot 10^{-5}$ was namely found instead of the theoretical value $4 \times 140 \cdot 10^{-5}$, from which $n_k = 3,82$ would follow ¹⁾.

Accordingly we have for the yellow phosphorus (also a_k will be $= a_1$):

$$\varphi = f_1 \mu_1 \times \frac{n_1}{n_k} = 5,52 \times \frac{1}{4} = 5,52,$$

whereas the following equation holds for the red phosphorus:

$$\varphi' = f_1' \mu_1' \times \frac{n_1'}{n_k} = 1,31 \times \frac{10}{1} = 5,24.$$

The accurate value of φ lies, therefore, probably in the neighbourhood of $5^{1/2}$.

[When we examine the values found for S, Se, and Te in the same light, we shall have to bear in mind with regard to the last elements that on account of the dissociation into isolated atoms the attraction at T_k will be another than at the triple point.

For *Sulphur* the molecular formula is probably $S_{6,3}$ at T_k (see above), that at T_t being S_8 for both modifications. Hence n_1 will be $= 8$, $n_k = 6,3$ in (1), so that $n_1 : n_k$ becomes $= 1,27$, and the value of φ will now become $= 4,28 \times 1,27 = 5,4$.

For *Selenium* $n_k = 2 (1 + n_k) = 2 \cdot 1,32 = 1,52$, but at the triple point n_1 will probably be $= 6$ ²⁾. We find, therefore, 3,96 for the ratio $n_1 : n_k$. Further $\sqrt{a_1} = 7,1 \cdot 10^{-2}$, $\sqrt{a_k} = 14,3 \cdot 10^{-2}$, hence $a_1 : a_k = 0,247$, so that $f_1 \mu_1$ must finally be multiplied by 0,98. Accordingly the value of φ would become $= 4,85$ here.

For *Tellurium* $n_k = 2 \cdot 1,79 = 1,12$, $n_1 = 6$, hence $n_1 : n_k = 5,37$. But $\sqrt{a_1}$ is about $9 \cdot 10^{-2}$, $\sqrt{a_k} = 25,5 \cdot 10^{-2}$, hence $a_1 : a_k = 0,125$. We must therefore multiply by 0,669, through which 7,10 passes into 4,75.

Except for O_2 , where $\varphi = 3,85$ (possibly also oxygen is associated at the triple point, up to e.g. $n_1 = 2,5$, which would render $\varphi = 4,8$), we find, therefore, after due correction everywhere a value in the neighbourhood of 5 for the triple point ratio $(v_1 - b_1) : v_1$.

¹⁾ According to PREUNER and BROCKMOLLER (loc. cit.) the dissociation constant (at 1 atm.) of the reaction $P_4 \rightarrow 2P_2$ is still slight even at 800°C , which will, therefore, be the case in a much greater degree at a pressure of 83 atm. At 800°C . $c_2^2 : c_4 = 0,00855 : p$ holds for this reaction, i.e. $c_2^2 : c_4 = 0,0001$ with $p = 83$, which gives $c_2 = 0,01$ when c_4 is near 1. [For the reaction $P_2 \rightarrow 2P_1$ we have $c_1^2 : c_2 = 0,000046 : p$, so that $c_1^2 : c_2$ becomes $= 0,00000055$ for 83 atm., hence $c_1 = 0,00074$, referring to $c_2 = 1$].

²⁾ In analogy with sulphur also Se_3 -molecules will probably be present at low temperatures.

Also for a more accurate calculation of the values of φ for Br₂ and I₂ (see § 1) n_k must be known. For n_1 the normal value 2 can be taken in both cases.¹⁾

As $n_1 : n_k = 2 : (2 : 1,048) = 1,048$, and $a_1 : a_k = (7 : 8,0)^2 = 0,766$ for *Bromine*, we must multiply by the factor 0,803, which would render $\varphi = 3,20 \times 0,8 = 2,6$.

For *Iodine*, where $n_1 : n_k = 1,104$, $a_1 : a_k = (9 : 11,1)^2 = 0,657$, the correction factor becomes 0,725, so that φ becomes $= 3,14 \times 0,725 = 2,3$.

In connection with the value 3,4 found for chlorine, the found values are rather small, which would point to this, that the ratios $a_1 : a_k$ have been taken too great, because the degrees of dissociation have possibly been calculated slightly too high — unless also for Cl₂ the too high value of $\sqrt{a_k}$ (viz. 5,4 instead of 5) should point to a slight dissociation at T_k , through which also here $a_1 : a_k$ becomes < 1 .

In the group of the noble gases the exceptionally high value 5,26 for Helium is certainly striking. This value is, however, lowered, when we assume that $\sqrt{a_1}$ suddenly becomes very small at so low a temperature as 1° abs. — hence presents an abrupt difference analogous to that of the electrical resistance at extremely low temperatures, as has been found by K. ONNLS].

Of the *compounds* of Phosphorus we have still examined PCl₃ and POCl₃, chiefly with a view to the fact that before (see I) for PH₃ the attraction of the central P-atom was found = 0.

	T_k	$b_k \cdot 10^5$	$a_k \cdot 10^4$	$\sqrt{a_k} \cdot 10^2$	
PCl ₃	558,6	$140 + 3 \times 115 = 485$	347,3	18,6	$P = 2,4 \cdot 10^{-2}$
POCl ₃	604,9	$140 + 70 + 345 = 555$	430,2	20,7	$P = 1,8 \cdot 10^{-2}$

When we assume Cl = 5,4, O = 2,7, we find, therefore, for the attraction of P in these compounds about half the theoretical fundamental value 5. [When we diminish Cl to 5,2, then 2,4 becomes 3,0 and 1,8 becomes 2,4. In HCl, namely, Cl has been found = 5,2, in CCl₄ even = 5 (all this $\times 10^{-2}$)]. Just as the value found for S was 0,6 unit lower for SOCl₂ than for S₂Cl₂, the value of P found for POCl₃ is here too 0,6 lower than for PCl₃ (influence of the inserted oxygen).

¹⁾ Prof. P. DUTOIT had the kindness to confirm the certainty of this fact for Br₂, and the high probability for I₂.

c. **Arsenicum.** The triple point of this substance seems to lie at 817°C . according to GOUBEAU (1914). At least at this temperature Arsenicum has been melted under pressure. The boiling point (sublimation point at 1 atm.) may be calculated from the series of vapour-pressure determinations of PREUNER and BROCKMÖLLER (loc.cit.). The latter namely found the following sublimation pressures at the indicated temperatures

$t = 400^{\circ} 45^{\circ} 470^{\circ} 476^{\circ} 488^{\circ} 500^{\circ} 512^{\circ} 526^{\circ} 557^{\circ} 569^{\circ} 580^{\circ} 600^{\circ}\text{C}$.
 $p = 6 \quad 19 \quad 28 \quad 32 \quad 44 \quad 61 \quad 90 \quad 130 \quad 268 \quad 334 \quad 430 \quad 586 \text{ mm.}$

From this we can calculate p_k and T_k by approximation (see II); we then find, also in connection with the values of a_k and b_k (see further below):

$$p_k = 95000 \text{ mm.} = 125 \text{ atm.}; \quad T_k = 1320^{\circ} \text{ abs.} = 1047^{\circ} \text{ C.}$$

If with these values according to VAN DER WAALS'S vapour pressure formula we calculate the corresponding values of F , then with $\log^{10} p_k = 4,978$ from

$$F_{10} = \frac{4,978 - \log^{10} p}{(1320 : T) - 1},$$

where p must be expressed in mm. and T in absolute degrees, we find the following values:

$T = 673 \quad 723 \quad 743 \quad 749 \quad 761 \quad 773 \quad 785 \quad 799 \quad 830 \quad 842 \quad 853 \quad 873$
 $F_{10} = 4,37 \quad 4,48 \quad 4,55 \quad 4,56 \quad 4,54 \quad 4,51 \quad 4,44 \quad 4,39 \quad 4,32 \quad 4,32 \quad 4,28 \quad 4,32$

The mean value is $F_{10} = 4,42$ ($F = 10,18$); the mean at the four highest temperatures is $4,31$ ($F = 9,93$). From this latter mean we now calculate easily that the value of T_k , that corresponds to $p = 760 \text{ mm.}$, is $T_k = 888$, i.e. $t_k = 615^{\circ}\text{C}$. This, therefore, is the temperature where the sublimation pressure amounts to 1 atm. (and not 450°C ., as was given by CONECHY in 1880. The pressure is then only 19 mm. instead of 760 mm.).

From the same formula $p_{10} = 11720 \text{ mm.} = 15,4 \text{ atm.}$ is found for the pressure which corresponds to the above given triple point $817^{\circ}\text{C} = 1090^{\circ}\text{ abs.}$

If the found temperatures are correct, we find $T_k : T_s = 1320 : 888 = 1,49$, a plausible value. [for N_s was found 1,61, for P (red) 1,41]. For $T_k : T_{10}$ we calculate $1320 : 1090 = 1,21$ (for red phosphorus 1,12).

The high value found for F is not very surprising. For as we have found $F_k = 8\gamma$ in an earlier series of Papers ¹⁾, and as $2\gamma = 1 + 0,038 \sqrt{T_k} = 2,38$, i.e. $\gamma = 1,19$ is calculated from

¹⁾ These Proc. of March 26, 1914, p. 808; April 23, p. 924; May 29, p. 1047; Sept. 26, p. 451.

$T_k = 1320$ abs. with our approximate formula, F_k would be $= 9,52$, only slightly divergent, therefore, from the value $9,93$ found just now for the equilibrium solid-vapour, calculated at 830° à 870° abs.

With $\gamma = 1,19$ we can now also calculate the factor f_1 . We find: ($m_1 = 1090 : 1320 = 0,826$):

$$f_1 = 2,38 \left[1 - \frac{1,19}{2,19} \times 0,826 \right] = 2,38 (1 - 0,449) = 1,312.$$

Now we ought to know the density at the triple point. But the calculation of this from the given density at 14° C. is rather unreliable, as 817° is too far from 14° C., and also the application of the coefficient of expansion determined at 50° C. is certainly not valid. In order to be able to determine the value of b_k notwithstanding with some approximation from the density at 14° C., we shall calculate f for this temperature ($T = 287$, $m = 0,217$). We find then:

$$f = 2,38 \left[1 - \frac{1,19}{2,19} \times 0,217 \right] = 2,38 (1 - 0,118) = 2,099.$$

As $v = 71,2 \cdot 10^{-5}$ corresponds to $D = 4,7$ (amorphous), b_k would become $= 150 \cdot 10^{-5}$ instead of $195 \cdot 10^{-5}$. Probably, therefore, the assumed value of D is too high. Only with $D = 3,62$ we should have found the expected value of b_k . In this connection we remark that $D = 3,70$ has been found for the amorphous brown-black Arsenicum (GEUTHER, 1887). Then $A : D$ would become $= 20,26$, $v = 90,40 \cdot 10^{-5}$, hence $b_k = 190 \cdot 10^{-5}$, which comes nearer to the theoretical value $195 \cdot 10^{-5}$.)

We arrive, therefore, at the right result, if only the density of the "brown-black" modification, which is much slighter than that of the amorphous Arsenicum, is taken as the foundation of the calculation.

We find for the product $f_1 t_1$:

1) If for this modification we apply the formula of the straight diameter as first approximation, then

$$D_1 + D_1' = 3,7 - 0,932 \times 2,38 (0,826 - 0,217) = 2,35$$

would follow from $D_1 + D_1' = (D + D') - D_k \times 2\gamma (m_1 - m)$, when D' is neglected at 14° C., and the value $0,932$ is taken for the calculated value D_k .

And as generally $b_k = [A : (D_1 + D_1') : 22412] \times f_1$, b_k becomes $= 142,3 \cdot 10^{-5} \times 1,312 = 187 \cdot 10^{-5}$ for 1 Gr. atom, also in the neighbourhood of $195 \cdot 10^{-5}$.

The value assumed just now for D_k follows from the relation (These Proc. loc. cit.) $v_k = r b_k = \frac{1 + \gamma}{\gamma} b_k = \frac{2,19}{1,19} \times 195 \cdot 10^{-5} = 358,8 \cdot 10^{-5}$. Expressed in ordinary units this is $358,8 \cdot 10^{-5} \times 22412 = 80,41$; for 1 Gr. therefore $80,41 : 74,96 = 1,073$. Hence $D_k = 0,9322$.

$$f_1 u_1 = 1,312 \times 1,21 = 1,59.$$

The value of φ is obtained from this by multiplication by $a_1 n_1 : a_k n_k$. We shall directly find the value $11,72 \cdot 10^{-2}$ for $\sqrt{a_k}$, so that a_k becomes $= 137,4 \cdot 10^{-4}$. Further $\sqrt{a_1} = 7 \cdot 10^{-2}$, hence $a_1 : a_k = 0,357$. If we again take $n_1 = 16$, just as for red phosphorus at the transition liquid-solid, $n_k = 4 : 1,616 = 2,48$ (see below), then $n_1 : n_k$ becomes $= 6,46$. Hence $a_1 n_1 : a_k n_k$ would become $= 2,31$. But this renders φ no more than $1,59 \times 2,31 = 3,66$ instead of 5 or higher. Most probably, therefore, the value of a_k has been taken too high, or the degree of association of liquid Arsenicum at the triple point is still higher than 16.

In connection with this we once more draw attention to what was found for *red* phosphorus, which modification is quite analogous to the *ordinary* arsenicum, whereas the *yellow* phosphorus seems to correspond with the *brown-black* Arsenicum. [density red P 2,20, yellow 1,83: only this latter value gave good results. Ordinary Arsenicum $D = 4,7$, brown-black 3,7: again only the latter value gives correct results. Triple point red P is high ($589^\circ,5$ C.) with a pressure of 43 atm. and near T_k (695° C.); triple point ordinary As also very high (817° C.) with a pressure of 15 atm. and again near T_k (1050° C.)]. It was namely found for the red P. by SCHENCK (See inter alia HOLLEMAN, Leerboek I, 2nd edition p. 223—224), that the polymerisation state must be considerably higher there than P_8 . Accordingly we may safely assume a degree of association both for red P and for ordinary As of at least 16 at the triple point.

The above used value of a_k is calculated in the following way. We find the value $a_k = 340,1 \cdot 10^{-4} : n_k$ (for $\theta = [28 : (8\gamma - 1)] \times [\gamma : (\gamma + 1)]^2$ is found 0,970), hence, $\sqrt{a_k} = 18,44 \cdot 10^{-2} : \sqrt{n_k}$ with $T_k = 1320$, $b_k = 195 \cdot 10^{-5}$ from the formula $T_k = 78 \theta n_k \times a_k : b_k$. Now at the critical temperature n_k is certainly $< 4^1$, so that $\sqrt{a_k}$ will be $> 9,2 \cdot 10^{-2}$. And as the normal (theoretical) value for As amounts to $7 \cdot 10^{-2}$, there is necessarily already splitting up into isolated atoms As_1 at T_k , which exhibit a so much greater attraction ($\sqrt{a_k} =$ about $30 \cdot 10^{-2}$). If we assume that the molecules As_4 split up directly into As_1 , without passing through the transition stage As_2^2 , we may put $n_k = 4 : (1 + 3x)$, when x is the degree, of

¹) According to PREUNER and BROCKMÖLLER (loc cit.) $c_2^2 : c_4$ would be $= 0,066 : p$ at 1100° C. for $As_4 \rightarrow 2As_2$, hence at a pressure of 125 atm. $c_2^2 : c_4 = 0,00053$, or $c_2 = 0,023$, when c_4 is near 1. Further $c_1^2 : c_2 = 0,013 : 125 = 0,00010$, i. e. $c_1 = 0,01$, referring to $c_2 = 1$, would hold for the reaction $As_2 \rightarrow 2As$ (also at 1100° C.).

²) Indeed, if we assumed a slight splitting up into As_2 then, of this almost every-

dissociation, so that for the calculation of x we shall have:

$$9,22 \sqrt{1+3x} = 7(1-x) + 30x,$$

giving $x = 0,205$, hence $\sqrt{1+3x} = 1,271$, and $\sqrt{a_k} = 9,22 \cdot 10^{-2} \times 1,271 = 11,72 \cdot 10^{-2}$. In this it should be observed that when the attraction of the isolated atoms should be greater instead of $30 \cdot 10^{-2}$, the value of x will be found smaller; also in the case that the normal attraction of As in compounds should be greater than $7 \cdot 10^{-2}$.

If really $\sqrt{a_k}$ is $= 11,72 \cdot 10^{-2}$, then follows for the critical pressure:

$$p_k = \frac{1}{28} \frac{a_k}{b_k^3} = \frac{137,4 \cdot 10^{-4} \times 0,970}{28 \times 380,25 \cdot 10^{-8}} = 125,2 \text{ atm},$$

in agreement with the value calculated above from the vapour pressures¹⁾.

We may now proceed to give the calculation of a few Arsenicum compounds, viz. of AsH_3 and AsCl_3 .

thing would have been converted to As_1 — in virtue of the comparatively high value of x (the degree of dissociation $\text{As}_4 \rightarrow \text{As}_1$), viz. 0,2.

1) From the vapour pressures determined at 557° and 600° C we calculate namely easily (see Paper II) $F_{10} \times T_k = 5727$, $F_{10} + \log^{10} p_k = 9,3270$ (in which p_k is expressed in mm.). Further follows from this and from the equations

$T_k = 78 \text{ } \epsilon \text{ } n_k \times a_k : b_k$, $p_k = \frac{1}{28} \text{ } \epsilon \text{ } \times a_k : b_k^3$, $\sqrt{a_k} = (7 + 23x) \cdot 10^{-2}$, in which $= 0,97$, $b_k = 195 \cdot 10^{-5}$, $n_k = 4 : (1+3x)$ and p_k in atm., the perfectly accurate values

$$T_k = 1316^\circ \text{ abs.}; p_k = 124,6 \text{ atm.}; F_{10} = 4,351; \sqrt{a_k} = 11,69 \cdot 10^{-2}; \\ x = 0,2041$$

through a calculation of approximation for the five unknown quantities T_k , p_k , F_{10} , a_k and x .

For p_k we found in round numbers 125 atm.; for T_k 1320° abs. If we take 1316° , the somewhat higher values 4,39, 4,51, 4,58, 4,59, 4,57, 4,54, 4,47, 4,42 4,35, 4,35, 4,31, 4,35 are found for the values of F_{10} corresponding with the different vapour pressures, so that we duly find 4,35 for the 9th and 12th values in agreement with what precedes.

We may add that T_k and p_k (in atm.) are connected through the equation $T_k = 5727 : (6,4462 - \log^{10} p_k)$. Further evidently $p_k \times (28 b_k^3 : \epsilon) = (7+23x)^2 \cdot 10^{-4}$, $T_k \times (b_k : 78 \text{ } \epsilon) = 4(7+23x)^2 \cdot 10^{-4} (1+3x)$, so that after elimination of T_k and p_k the following equation remains:

$$\frac{4(7+23x)^2 \cdot 10^{-4}}{1+3x} \frac{78 \text{ } \epsilon}{b_k} = 5727 : \left[6,4462 - \log^{10} \left\{ (7+23x)^2 \cdot 10^{-4} \frac{\text{ } \epsilon}{28 b_k^3} \right\} \right].$$

or also:

$$\frac{(7+23x)^2}{1+3x} = 369,0 : [6,4866 - \log^{10} (7+23x)^2],$$

from which then $x = 0,2041$ is calculated. From this $\log^{10} p_k = 2,0955$, $p_k = 124,6$. Etc. Etc.

	T_k	$b_k \cdot 10^5$	$a_k \cdot 10^4$	$\sqrt{a_k} \cdot 10^2$	
AsH ₃	382	$195 + 3 \times 34 = 297$	145,5	12,1	As = $2,5 \cdot 10^{-2}$
AsCl ₃	629	$195 + 3 \times 115 = 540$	435,3	20,9	As = $4,7 \cdot 10^{-2}$

The critical temperature of AsH₃ was calculated from that of the boiling point (218°,3 abs.), multiplied by 1,75 (factor 1,69 for NH₃, 1,75 for PH₃). For AsCl₃ 629° abs. has been given as "calculated"; as $T_s = 403°,3$, the ratio would here be 1,56 (for PCl₃ it was 1,60). In any case we find *diminished* attraction for the said compounds. For AsCl₃ about 5 instead of 7, for AsH₃ not 0 as for NH₃ and also still for PH₃, but about half 5, i.e. 2,5 (H assumed = 3,2). [If we take for H half the value 1,6, we should find the value $7,3 \cdot 10^{-2}$ for As, i.e. about the normal value $7 \cdot 10^{-2}$].

d. Antimonium. The melting point is very accurately known, viz. 630°,0 C. according to DAY and SOSMAN (1912). [In 1911 629,8 or 629,2 had been given]. The boiling point lies at 1440° C. according to GREENWOOD (1909). At this temperature the molecular weight of the vapour would already be $< Sb_4$ (MENSCHING and V. MEYER), which is confirmed by the calculation of the value of \sqrt{a} at the critical temperature. With $T_k : T_s = 1,75$ [for N₂ this ratio was 1,61, for yellow Phosphorus 1,75, for the brown-black Arsenicum unknown; we must namely compare with the said modifications, where just as for Sb the boiling point lies higher than the triple point] we calculate for T_k the approximated value 2998°, i.e. in round numbers 3000° abs.

Then the value $1057 \cdot 10^{-4}$: n_k follows for a_k from $T_k = 78 \theta n_k \times a_k : b_k$ with $\theta = 0,909$ and $b_k = 250 \cdot 10^{-5}$, or for $\sqrt{a_k}$ the value $32,51 \cdot 10^{-2} : \sqrt{n_k}$.

If again we suppose, just as for As₄, a direct decomposition of Sb₄ into Sb₁, Sb₂ being skipped, then $n_k = 4 : (1 + 3x)$, hence $\sqrt{a_k} = 16,26 \cdot 10^{-2} \times \sqrt{1 + 3x}$. The normal theoretical value being = 9, this points to a great dissociation to simple molecules Sb₁. If for the attraction of them we again assume a value in the neighbourhood of $30 \cdot 10^{-2}$, a value > 1 follows for x from

$$16,3 \sqrt{1 + 3x} = 9(1 - x) + (\pm 30)x,$$

so that $x = 1$ must be assumed, unless for $\sqrt{a_{k_1}}$ a value is assumed $> 32,5 \cdot 10^{-2}$. The dissociation to Sb₁ is therefore complete, and we

can put $\sqrt{a_k}$, at least $32,5 \cdot 10^{-2}$. This would probably be also the value of the attraction of the isolated atoms Sn, Te, I, which elements are in the same row of the periodic system with Sb. The "residual attraction", i.e. when the atom valencies are saturate for *compounds*, is for all these elements $= 9 \cdot 10^{-2}$, which attraction is also found for the *atoms* of the valenceless Xenon.

Antimonium is the first element in our successive treatment of the different element groups, where the *atom* attraction *fully* manifests itself, and it can, therefore, not only be estimated, but also calculated. In our previous calculations of the degree of dissociation we have, therefore, assumed the preliminary value $30 \cdot 10^{-2}$ as correct by approximation.

For the quantity 2γ we find the value 3,08, hence $\gamma = 1,54$ from our formula $2\gamma = 1 + 0,038\sqrt{T_k}$. At the triple point m_1 is $= 904,1$: $3000 = 0,301$, $\mu_1 = 3,32$, and f_1 becomes :

$$f_1 = 3,08 \left[1 - \frac{1,54}{2,54} \times 0,301 \right] = 3,08 (1 - 0,183) = 2,519,$$

so that $f_1 \mu_1 = 8,37$. This must now again be multiplied by $a_1 n_1$: $a_k n_k$. As $\sqrt{a_1} = 8,9 \cdot 10^{-2}$, $\sqrt{a_k} = 32,5 \cdot 10^{-2}$, $a_1 : a_k$ becomes $= 0,0750$. Further $n_k = 1$, n_1 perhaps $= 8$ (for Phosphorus and Arsenicum 16 had to be assumed for this), hence $a_1 n_1 : a_k n_k = 0,6$. With this μ would become $= 5,02$.

For the density of Antimonium at 15° C. 6,618 is given (KAHLBAUM, 1902). This gives $A : D = 18,16$, $v = 81,27 \cdot 10^{-5}$. The factor by which we must multiply to obtain b_k — because $m = 288 : 3000 = 0,096$, is:

$$f = 3,08 \left[1 - \frac{1,54}{2,54} \times 0,096 \right] = 3,08 (1 - 0,0582) = 2,902.$$

We shall, therefore, calculate $81,27 \cdot 10^{-5} \cdot 2,902 = 235,8 \cdot 10^{-5}$ for b_k , whereas the 6% higher value $250 \cdot 10^{-5}$ found for compounds was expected. If the density were 6,2¹⁾ instead of 6,6, or if the factor f were slightly higher, in consequence of γ being on an average e.g. 1,63 instead of 1,54 — which is very well possible, as part of the range from 15° to 3000° passes over the solid state (viz. 15° to 630°) — then for b_k the expected value would have been found.

Of the Antimonium *compounds* — of these we already treated

¹⁾ HÉRARD (1889) actually found the value 6,22 for amorphous Sb (98,7 %). But in contradiction to this is the fact that TOEPLER found $D_1 = 6,41$ at the melting point in 1894, which would have yielded a still lower value for b_k .

the halogen compounds in II, where for $\sqrt{a_k}$ the full value $9 \cdot 10^{-2}$ was found — we shall still examine SbH_3 .

	T_k	$b_k \cdot 10^5$	$a_k \cdot 10^4$	$\sqrt{a_k} \cdot 10^2$	
SbH_3	446	$250 \div 3 \times 34 = 352$	201,3	14,2	$\text{Sb} = 4,6$

The critical temperature of SbH_3 was calculated from $T_s = 255^\circ$ abs., which gives $T_k = 446^\circ$ abs. with $T_k : T_s = 1,75$ (see for AsH_3). We therefore find for $\sqrt{a_k}$ about *half* the normal value 9. Noteworthy is the fact that when again we take for AsH_3 for H not 3,2, but the half value 1,6, we should have found $\text{Sb} = 9,4 \cdot 10^{-2}$, i.e. about the normal theoretical value.

e. **Bismuth.** According to ADAMS and JOHNSTON (1912) the melting point lies at $271^\circ,0 \text{ C.} = 544^\circ,1$ abs. (EGGINK found $271^\circ,5$ in 1908). The boiling point lies at 1435° C. , according to BARUS (1894), whereas GREENWOOD (1910) found the somewhat lower value $1420^\circ \text{ C.} = 1693^\circ$ abs. With 1,75 as factor T_k would, therefore, be $= 2963^\circ$. If we assume in round numbers 2960° , the value $1271 \cdot 10^{-4} : n_k$, follows for a_k from $T_k = 78 \theta n_k \times a_k : b_k$ with $\theta = 0,910$, $b_k = 305 \cdot 10^{-5}$; hence $\sqrt{a_k} = 35,65 \cdot 10^{-2} : \sqrt{n_k}$.

Just as for Sb, this points to $n_k = 1$, so that we find the high value $35,6 \cdot 10^{-2}$ for the atomic attraction of Bismuth.

For 2γ we find the value 3,068, hence $\gamma = 1,534$, from our approximate formula. In consequence of this, f_1 becomes with $n_1 = 544,1 : 2960 = 0,184$:

$$f_1 = 3,068 \left[1 - \frac{1,534}{2,534} \times 0,184 \right] = 3,068 (1 - 0,111) = 2,727,$$

on account of which $f_1 \mu_1$ assumes the value 14,83 with $\mu_1 = 5,44$. Now $\sqrt{a_1} = 11 \cdot 10^{-2}$, $\sqrt{a_k} = 35,65 \cdot 10^{-2}$, hence $a_1 : a_k = 0,0952$. If further $n_k = 1$, $n_1 = 4$ (i. e. if at the triple point 271° C. the liquid-solid bismuth $= \text{Bi}_4$), then $a_1 n_1 : a_k n_k = 0,381$, hence $\rho = 5,65$.

ADAMS and JOHNSTON (1912) found $D = 9,802$ for the density at 15° , KAHLBAUM (1902) gives 9,791. By an electrolytic way (CLASSEN, 1890) 9,747 was found, and HÉRARD gives 9,483 for amorphous bismuth (contained 0,4 % O_2). At the melting-point VICENTINI and OMODEI (1888) give the value 9,673 for the solid bismuth, 10,004 for the liquid bismuth. (ROBERTS and WRIGHTSON had found the almost identical value 10,039 in 1882).

If we take A. and J.'s value at 15° C. as basis for the calculation, $A : D$ would become = 21,22, $v = 94,70 \cdot 10^{-5}$, so that we find for b_k with

$$f = 3,068 [1 - 0,6054 \times 0,0973] = 3,068 (1 - 0,0589) = 2,887$$

the value $b_k = 273,4 \cdot 10^{-5}$, though the value $305 \cdot 10^{-5}$, which is more than 10% higher, was expected. Either the critical temperature, and because of this also γ , has been estimated too low, or the density has been assumed too high. But the latter is not very probable in view of the still greater value at the melting point.

In connection with the values of T_k and p_k we still draw attention to a series of vapour pressure determinations of GREENWOOD (1910). If $\sqrt{a_k}$ is really = $35,65 \cdot 10^{-2}$, as we found above, and $b_k^2 = 305 \cdot 10^{-2}$, $p_k = 444,3$ atm., $\log^{10} p_k = 2,6477$ would follow from $p_k = \frac{1}{23} \theta \times a_k : b_k^2$.

We find the vapour pressure factor F_{10} of VAN DER WAALS'S formula $\log^{10} (p_k - p) = F_{10} (T_k/T - 1)$ therefore from

$$F_{10} = \frac{2,648 - \log p}{(2960 : T) - 1}$$

From:

$T = 1473^\circ$	1583°	1693°	2013°	2223°	2333° abs.
$p = 102$	257 mm.	1	$6,3$	$11,7$	$16,5$ atm.

would then follow:

$$F_{10} = 3,49 \quad 3,59 \quad 3,54 \quad 3,93 \quad 4,76 \quad 5,32.$$

The rise of the value of F need not astonish us, when we think that the state of nothing but simple molecules has not been reached from the outset, and that at 1500° abs. molecules Bi_2 (or Bi_4) can very well be present. The attraction is then smaller than the final value $\sqrt{a_k} = 35,6 \cdot 10^{-2}$, so that also T_k will be smaller than 2960° abs. And this is accompanied with a decrease of the value of F . But yet the increase seems somewhat too great to us, because according to the formula $F_k = 8\gamma$ the value of F at the critical point will have to be about = 12,3, i.e. $F_{10} = 5,33$. And with $T_k = 2960^\circ$ abs. the value of F would already be = 5,3 at 2333°, and evidently be still increasing.

If we assume $T_k = 3000^\circ$ abs., we should find the following values of F :

$$F_{10} = 3,40 \quad 3,49 \quad 3,44 \quad 3,78 \quad 4,54 \quad 5,02,$$

which increase less rapidly at the highest temperatures, and remain below 5,35.

If $T_k = 3000^\circ$ abs., also a_k would become slightly greater, viz. (θ is now = 0,909) $a_k = 1290 \cdot 10^{-4}$, which would render $\sqrt{a_k} = 35,92 \cdot 10^{-2}$. The value 2γ would become 3,081 instead of 3,07, on

account of which $\gamma \cdot (1 + \gamma) = 0,606$. For p_k we further find the value 450,1 atm. ($\log^{10} p_k = 2,6533$). By means of this we then find the above values of F_{10} .

Now $F = 8\gamma = 12,32$ is expected for the value of F at T_k , hence $F_k = 5,35$ about. This then would be the limiting value, which is reached at the critical temperature.

At $T_k = 2960^\circ$ abs. the ratio $T_k : T_s$ was 1,75, at 3000° abs. this ratio will be = 1,77. And for $T_k : T_u$ we find 5,51. (For m_1 the value 0,181). Etc.

At any rate the critical temperature of Bismuth lies in the neighbourhood of 3000° abs. with an uncertainty of perhaps a few tens of degrees. And the critical pressure in the neighbourhood of 450 atm. with an uncertainty of a few units. From this it is once more seen how great a value the knowledge of some vapour pressures has for the calculation of the critical data — also when as here the condition gradually develops from a mixture of molecules and atoms to nothing but atoms. For Arsenicum the critical temperature could likewise be fixed with a high degree of certainty at somewhat higher than 1300 abs. through the knowledge of the sublimation pressures. There at the temperatures at which the pressures were determined (700° à 900° abs.), the condition changed still very little, and the value of F remained beautifully constant.

Let us in conclusion recapitulate all that has been found in the following tabular survey. (p. 320).

At the critical point Nitrogen = N_2 ; Phosphorus = P_4 ; Arsenicum = As_4 , dissociated to As_1 to an amount of 0,2; Sb and Bi are = Sb_1 and Bi_1 , with the increased atomic attractions **33** and **35** about, i. e. 24 units higher than the normal (residual) attractions 7 and 9 (all this $\times 10^{-2}$) in compounds. (For Arsenicum the normal attraction 7 is only partially increased to almost 12).

It is still noteworthy that — where for NH_3 and PH_3 the attraction of the central N- or P-atom is entirely eliminated by the surrounding H-atoms — the attraction of the so much larger As- and Sb-atoms makes itself again partially felt for AsH_3 and SbH_3 . For As 2,5 (normal 7) instead of 0; for Sb 4,6 (normal 9) instead of 0.

Also for PCl_3 , $POCl_2$ and $AsCl_3$ *diminished* attractions are found, while we have seen in II that for $SbCl_3$ the attraction of Sb is again fully felt.

In conclusion we remark that for the Nitrogen group (Nitrogen itself excepted, unless we assume association at the triple point) the quantity $\bar{\varphi}$, by which the ratio $(v_1 - b_1) : v_1$ at the triple point is determined, seems to lie in the neighbourhood of 5 à 6. In the oxygen group

TABLE D₁.

<i>N</i>	<i>A</i>	<i>A/N</i>	<i>D</i> ₁	<i>A/D</i> ₁	$v_1 \cdot 10^5 = \text{id.} : 0,22412$	γ	γ'	<i>m</i> ₁	<i>f</i> ₁	$b_k \cdot 10^5$ calculated	$b_k \cdot 10^5$ found
7 N ₂	14,01	2,00	0,870	16,11	71,88	0,793	0,713	0,501	1,235	89	86 (85)
15 P ¹⁾	31,04	2,07	1,79	17,34	77,37	—	1,09	0,328	1,809	140	134 (140)
33 As ²⁾	74,96	2,27	3,70 (14°)	20,26	90,40	—	1,19	(0,826)	(1,343)	192	(195)
51 Sb	120,2	2,36	6,62 (15°)	18,16	81,27	—	1,54	0,301	2,519	236	(250)
83 Bi	208,0	2,51	9,80 (15°)	21,22	94,70	—	1,54	0,181	2,742	275	(305)

TABLE D₂.

	<i>T</i> _{tr}	<i>T</i> _s	<i>T</i> _k	<i>p</i> _k	<i>D</i> _k	$\frac{T_k}{T_s}$	$\nu_1 = \frac{T_k}{T_{tr}}$	<i>f</i> ₁ ^ν ₁	φ	$\nu a_k \cdot 10^2$ calculated	$\nu a_k \cdot 10^2$ in comp.	<i>x</i>
N ₂	63,06	78,00	125,96	33,49	0,311	1,61	2,00	2,47	2,47	2,6	2,9	0
P ₄ ¹⁾	317,2	553,6	968	82,8	—	1,75	3,05	5,52	5,52	6,4	6,4	0
As ₄ ²⁾	(1090)	(889)	1320	125	0,932	(1,48)	(1,21)	(1,59)	3,66?	11,7	7	0,2
Sb ₄	903,1	1713	3000	—	—	1,75	3,32	8,37	5,02	32,5	8,9	1
Bi ₄	544,1	1693	3000	450	—	1,77	5,51	15,1	5,67	35,9	11	1

we found $\varphi = 4$ à 5 ; in the halogen group = 3 à 4 ; in the group of the noble gases = 2 à 3 . Here an increase takes unmistakably place in the increase of the number of chief valencies from 0 to 3.

As $(v_1 - b_1) : v_1 = \frac{8}{27} : \varphi$, this ratio decreases from about $\frac{1}{8}$ for the Helium group to $\frac{1}{20}$ for the Nitrogen group. This is to say that for the first group the free volume at the solidification amounts to about $\frac{1}{8}$ of the total volume; for the latter group on the other hand only to $\frac{1}{20}$.

This, therefore, seems to be the law by which the *solidification* of the elements is governed.

In the following papers only such elements are considered, as are *entirely* dissociated to *atoms* at *T*_k (as up to now were only Antimony and Bismuth), and for which the *full*, exceedingly high *atomic attraction* manifests itself.

Clarens, June 1916.

¹⁾ All the experimental values and those derived from them refer to the yellow phosphorus.

²⁾ The values of *D*, *A* : *D*, *v* and *b*_k calculated refer to the *brown-black* modification, which corresponds to the yellow phosphorus; all the other values to the *ordinary* arsenicum, which is analogous with the red (greatly associated) phosphorus.

Physiology. — “*The Structure and Overlap of the dermatomes of the hindleg with the cat*”. By Dr. S. DE BOER. (Communicated by Prof. G. VAN RIJNBEEK).

(Communicated in the meeting of May 27, 1916)

I applied the same method that I made use of for the determination of succeeding dermatomes in the thoracic-lumbar region, for fixing the lines of demarcation of the dermatomes of the hindleg.

If we want to apply this method to the lower part of the spinal cord, we have to overcome a difficulty.

From the 5th lumbar root in a distal direction the succeeding roots are closely connected. At their origin from the spinal cord these roots are consequently not separated from each other, as is the case with all roots originating higher.

Consequently I acted as follows: The lumbar-sacral part of the spinal-cord was laid bare under ether-chloroform narcosis, the dura was split lengthwise. Then I sought the 4th lumbar root. I moistened then the spinal cord round the place of entrance of this hind-root with a solution of sulphate strychnini (1 %) coloured by methylene-blue. Sometimes the 3^d lumbarroot had previously been cut. When the cat had then awaked from the narcosis, the hyperreflectory field of lumb. IV was indicated on the skin with water-colour. Then this hindroot was cut under narcosis and at the place of egress of the following hindroot (lumb. V) the spinal cord was moistened with a solution of strychnine. Special care was taken, that in a distal direction the spinal cord was not moistened past the last radicularis of lumbalis V. Then the line of demarcation of this field was determined and marked on the skin. Every time different colours were made use of for the different fields. The succeeding root was then treated in the same way, till all following dermatomes of the hindleg, as far as sacralis 1 or 2 included, had been obtained. When I determined in this way the dermatomes, it is certain that the proximal limits could be obtained more accurately than the distal ones. The spinal cord round the proximal radicularia of each root can always be sufficiently moistened with a solution of strychnine, because the preceding root had been cut. In a proximal direction I never ran the risk of moistening too much or too little. I was not so certain however with regard to the distal radicularia. Though I moistened here as carefully as possible with a tapered piece of cottonwool the spinal cord to just behind the place of entrance of the last radicularis of each root, the uncertainty always remained

21

Proceedings Royal Acad. Amsterdam. Vol. XIX

here, that I moistened the spinal cord either too far or not far enough in a distal direction. If the last radicularis of a root is not likewise poisoned, then the field is a narrow zone too small in a distal direction, if, on the contrary, the proximal radicularis of the next following root is likewise poisoned, then the field is a narrow zone too large. We must consequently be mindful of these possible errors, when judging of our dermatomes. When now the dermatomes of the hindleg had been marked with different colours on the skin, then the cat was killed. On a plastermould I indicated then the dermatomes again with paints of different colours and then the skin of the hindleg was finally prepared. The skin was then tanned and deposited. An exact description of the course of the limits of the dermatomes I had obtained, was made by me immediately after the expiration of the experiment. Thereupon I proceeded to the section.

For this purpose the entire spinal cord, as far as the skull, was laid bare. The number of cervical, dorsal and lumbar vertebrae was counted. Counting from the skull I traced which hindroots had every time be experimented. If I found deviations in the situation of the fields pointing to prefixion or postfixion of the hindleg, or if the number of the different sorts of vertebrae deviated from the normal number, the plexus was laid bare and examined. Deviations of the plexus were marked, a scheme of the plexus was drawn, and usually the plexus was then extirpated, pinned to a waxplate and fixed in a solution of formol.

In this way I obtained a representation on a plastermould of all the dermatomes I had determined, in such a way that the dermatomes determined on one hindleg, were transferred to a plastermould, then I had the skins of the hindlegs on which the dermatomes were indicated, and at last an extensive description of the dermatomes. In this way I have determined the dermatomes of the left hindleg for 19 cats (I constantly took the left hindleg, as I had a plastermould of that hindleg, and it was of no consequence for my purpose on which hindleg I made my experiments).

The skin of every hindleg I had experimented on, was always finally prepared in the same way. The sections of the skin that I executed for this purpose followed the same lines in every hindleg as much as was possible. I proceeded for this purpose in the following way: First I applied a circular section through the trunk skin, beginning from the 4th lumbar vertebra perpendicular to the vertebral column towards the ventral medianline. A second section follows from the place where the former section passes the ventral medianline, along

the ventral medianline in a caudal direction to a short way on the tail. Then I applied a third section, beginning from the interdigital fold between the 2nd and the 3rd toe, over the middle of the planta pedis and the calcaneus; then this section is continued over the middle of the bellies of the calf muscles, through the fossa poplitea. Then the posterior rim of the upperleg is followed towards the symphysis in the direction behind the scrotum. A fourth section follows the dorsal medianline from the 4th lumbar vertebra to a little way on the tail. This section is united on the tail by a little transversal section, so that the ventral tailsection is hit at about 1 cm. distance from the spot where it begins at the insertion of the tail. The toes are successively peeled out by uniting the tops of the toes by means of sections following the middle of the webs. I shall begin by describing the dermatomes of the hindlegs of those cats with which I found no deviations at the plexus or the vertebral column.

Without constantly mentioning the fact, we have, in the first row to do with the dermatomes of the hindleg of cats that were in possession of 7 cervical vertebrae, 13 thoracal and 7 lumbar vertebrae, whilst there was no deviation in the plexus (median-class according to LANGLEY).

I shall begin by a description of the dermatomes of those cats with which the situation of the dermatomes does not deviate much from the average one. I use here expressively the word average and not normal, because it is my experience that there are not two cats to be found, with which the overlap of the dermatomes of the hindleg corresponds. The shape and situation of the dermatomes depends upon many factors, among which the level of the spinal cord on the spot where the hindleg develops itself, occupies a prominent place. This level of development oscillates round an average and so does likewise the shape and the extension of the dermatomes. A deviation from this average of an entire segment can even exist.

Cat 34 (4 Febr. (1916).

The spinal cord in the lumbar-sacral region is laid bare under ether-chloroform-narcosis, the dura is split lengthwise. The hindroot of lumbalis 3 is cut and the spinal cord moistened round the place of entrance of the hindroot of lumbalis 4 with sulphate strychnini 1% (coloured with methyleneblue). When the cat has awaked from the narcosis, the line of demarcation of the hyperreflexory field is marked on the skin.

Lumbalis IV. Anterior boundary. This proceeds from the dorsal medianline and runs 1 cm. behind the crista ilei in a somewhat caudal-distal direction to the groinfold, which is reached about the boundary between the posterior and the

central third part. Then the frontal boundary passes over on the ventral side of the body to reach the ventral medianline nearly in front of the symphysis.

Posterior boundary. This proceeds from the dorsal medianline, runs over the trochanter and reaches the frontal side of the lower leg 2 cm. below the patella, then passes upon the median plane of the leg and reaches the ventral medianline nearly in the middle of the symphysis. This root is cut under narcosis, and the spinal cord is moistened with sulphate strychnini 1% round the place of entrance of lumbalis V. The hyperreflectory field is marked on the skin.

Lumbalis V. Anterior boundary. The most proximal point of it lies nearly in the boundary between the central and the lower third part on the lateral plane of the upperleg. From here the frontal boundary extends with a curve to the centre of the patella, and then passes over to the interior of the lower leg. Directed with a slight convexity towards the posterior rim the boundary-line continues then in a distal direction between the malleolus internus and the calcaneus. Then the boundaryline passes over to the planta pedis, runs at a short distance from the medial footrim and follows this as far as the middle of the first toe. There the boundaryline turns with an acute angle in a proximal direction to the dorsal side of the foot. Over the latter the boundaryline continues in a proximal direction, passes the joint of the foot in the centre between the two malleoli, and proceeds first at 3 and afterwards at 1½ cm. distance from the posterior rim of the leg, till the point of issue is reached. This root is now cut under narcosis, and the spinal cord is moistened with a solution of strychnine round the place of entrance of the succeeding root.

Lumbalis VI. The most proximal point of this field falls just in the inferior part of the lateral plane of the upperleg, but more caudally and distally than that of the former field. From here the foremost boundaryline runs with a convex frontal curve in a distal direction, and passes the crista tibiae a little above the middle of the tibiae. The boundaryline is then continued on the medialplane of the lowerleg, and runs over the malleolus internus, then along the medial rim of the foot, in front of the ball of the foot and passes then between the 3^d and the 4th toe to reach the dorsal side of the foot. The boundaryline proceeds over the latter nearly parallel to the exterior rim of the foot, behind the malleolus lateralis, and then nearly parallel to the posterior rim of the leg to the point of issue. After this root has been cut under narcosis, the spinal cord round the place of entrance of the succeeding root is moistened with a solution of strychnine. After the awakening from the narcosis the hyperreflectoric field is determined and marked on the skin.

Lumbalis VII. The most proximal point of this lumbalis falls on the posterior rim of the lowerleg a little above the place where the calf muscles end and the tendon of Achilles begins. From here the boundaryline proceeds frontally with a convex curve and crosses the fibula a little above the malleolus lateralis, continues in front of this malleolus, in a slanting distal medial direction over the back of the foot and farther over the middle of the dorsal side of the 2nd toe, so that the medial side of the toe falls outside the field, passes over the end of the toe to the plantary side and proceeds then medially from the ball of the foot in a proximal direction. The boundaryline proceeds then along the medial rim of the foot over the posterior side of the malleolus medialis with an upward convexity to the point of issue. Now this root is cut, and the spinal cord round the place of entrance of the succeeding root is moistened with strychnine.

Sacralis I. Anterior boundary This field has at the dorsal and at the ventral side again contact with the medianline. The anterior boundaryline issues from the dorsal medianline, proceeds over the trochanter, coinciding with the posterior boundary of the field of lumbalis IV. On the middle of the upperleg these 2 boundarylines diverge. The anterior boundaryline proceeds then nearly parallel to the posterior rim of the leg to the malleolus lateralis, continues about $1\frac{1}{2}$ cm. past this malleolus, and turns then with an acute angle to the calcaneus. The inner-side of the leg is then reached over the calcaneus; then about the middle of the lower and the upperleg is followed towards the posterior boundary of the field of lumbalis IV; this is then farther followed to the ventral medianline.

Posterior boundary. This issues from the dorsal medianline near the root of the tail, proceeds over the tubel ossis Ischii with a curve under along the scrotum to the ventral medianline, which is reached at about the centre between the posterior rim of the symphysis and the opening of the anus. This root is now cut, and the spinal cord round the place of entrance of the succeeding root is moistened with a solution of strychnine. The hyperflexory field is determined.

Sacralis II. Anterior boundary. This issues from the dorsal medianline at about the centre of the former field, proceeds along the anterior side of the tubel ossis Ischii and reaches the ventral medianline behind the symphysis.

Posterior boundary. This issues from the dorsal medianline in the beginning of the root of the tail, proceeds frontally round the opening of the anus and reaches the ventral medianline between the scrotum and the opening of the anus. The scrotum falls consequently inside this field, and the anus outside it.

After these fields had been determined and marked on the skin of the cat with watercolour of different hues, these fields were transmitted to a plastermould, likewise in different colours. The skin is finally prepared in the way I described before, and tanned.

At the section it is ascertained that the cat had 7 cervical, 13 thoracal, and 7 lumbar vertebrae. As was presumed, the hindroots of lumbalis 4, 5, 6, 7 and sacralis 1 and 2 have been experimented on. Sketches were made of the arrangement of these fields on the skin of the hindleg, which I reproduce here in fig. 1 and 2¹⁾.

Fig. 1 represents the outside of the hindleg, fig. 2 the inside. A first glance teaches us already, that likewise on the hindleg the mutual overlap of the rootfields is considerable.

The overlap at the toes is likewise rather important. The skin of the toes is innervated from 3 hindroots (5, 6 and 7).

In the same way as I described above, I determined the dermatomes of the left hindleg with 19 cats.

From these determinations it appeared to me, that, also in this series of experiments, in which we had to do with cats showing no deviations, either of the vertebral column or at the plexus, the situation of the separate dermatomes is very inconstant.

¹⁾ The figures of this communication were drawn by Prof. WILLEM, to whom I pay my sincere thanks.

The variations of the sensitive field of lumbalis IV are not strong. I found this field always in connection both with the dorsal and

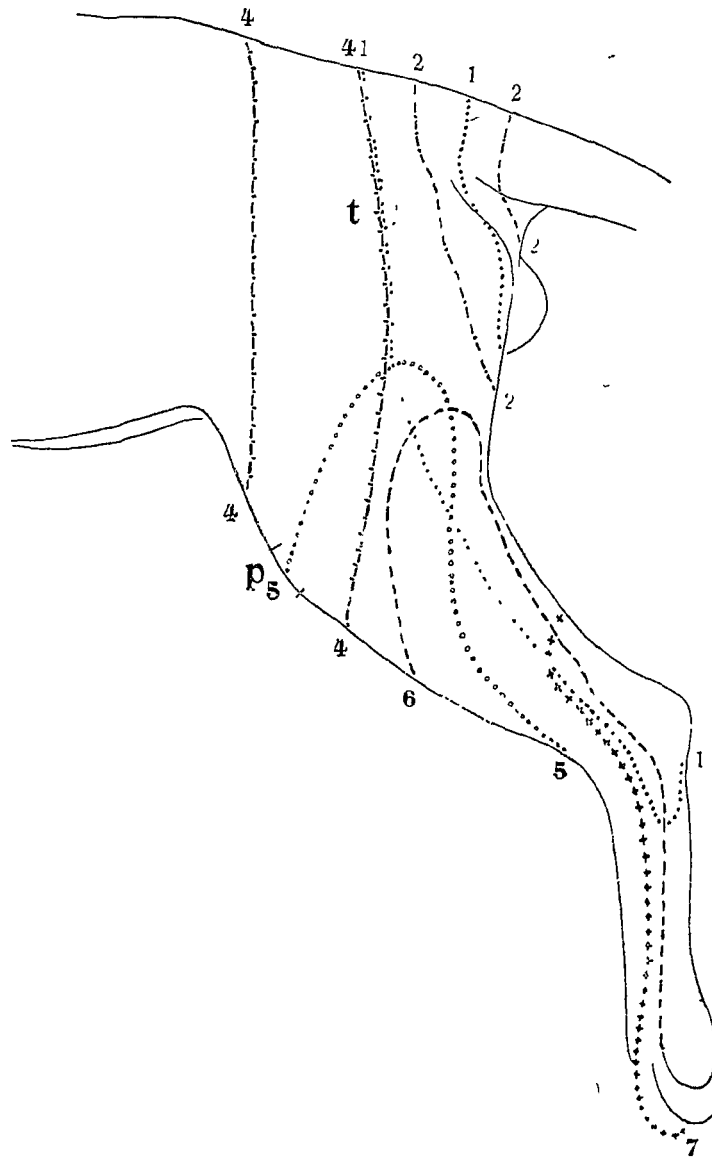

Fig. 1.

Left hindleg of a cat at the exterior side. The heavy figures indicate the ordernumber of the lumbar dermatomes. The thinner figures are placed at the boundaries of the sacralis. *t* = trochanter *p* = patella. For the innerside vide Fig. 2.

with the ventral medianline. Only with one cat a lap was extant at the innerside of the leg to the middle of the bellies of the calf-muscles. For the rest I always found deviations of the plexus,

when this lap was found at the field, and then it was also larger.
On the contrary the sensitive fields of lumbalis V, VI and VII

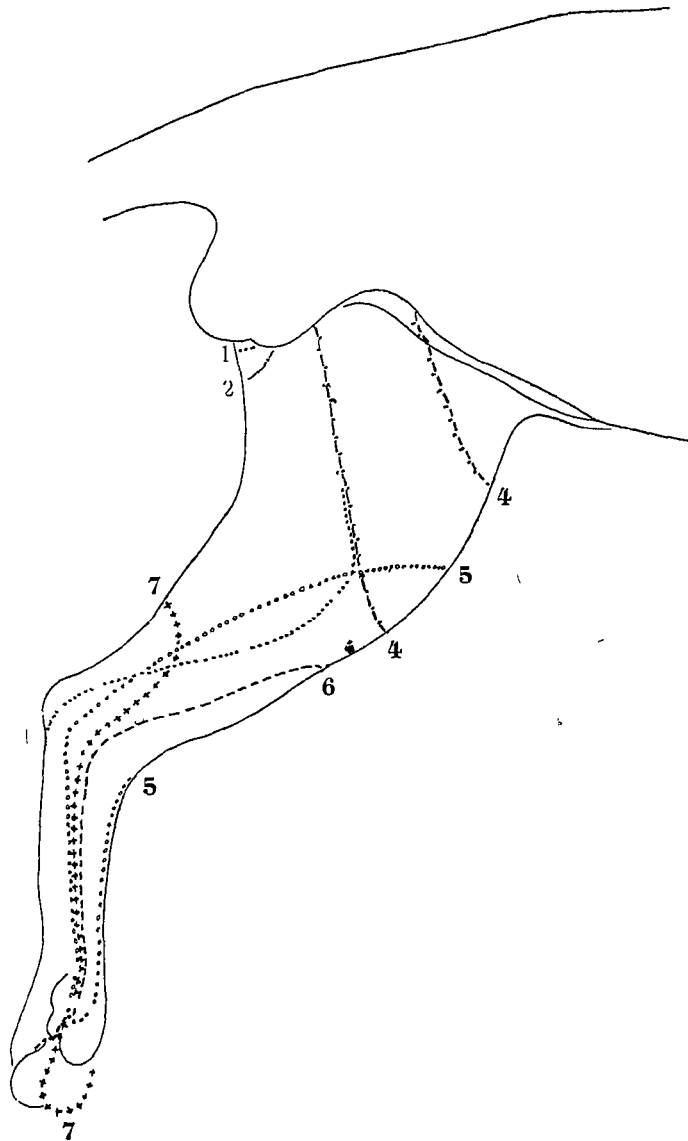

Fig. 2.

Left hindleg of the cat of Fig. 1 at the inner side. The heavy figures indicate the order-number of the lumbar dermatomes. The thinner figures are placed at the boundaries of the sacral segments.

had always lost every contact both with the ventral and with the dorsal medianline.

The situation and the dimension of these 3 topfields are subject to considerable fluctuations. So the proximal or, as WINKLER and

VAN RIJNBEEK call it, the top part of the field of lumbalis V now extends as far as half way the upper leg, now as far as above the trochanter. The height to which the sensitive field of lumbalis VI rises, varies likewise but not so much as with lumbalis V. These two dermatomes extend in their proximal parts almost entirely over the lateral side of the leg. Much less so on the innerside, as WINKLER and VAN RIJNBEEK found with the dog. These fields are, it is true, likewise with the cat turned inwardly. These distal slips into which these two fields are extended vary likewise very considerably. Now this slip extends with lumbalis V as far as the region between the malleolus internus and the calcaneus, now as far as half way the interior rim of the foot or the metatarsophalangeal joint. The most distal slips of this field extend as far as the first toe, even the entire first toe can fall inside this field. Lumbalis VI includes here the first, the first two or the first three toes.

The 3^d topfield offers likewise rather important variations in situation and extent. Usually the field reaches proximally as far as a few cm. above the calcaneus, but it can likewise here extend as far as the fossa poplitea. The field encloses then the foot laterally and plantary. Sometimes only the lateral toe falls inside this field, another time the 2 or the 3 lateral toes. Incidentally all the toes are innervated from this root. In this latter case this field encloses the foot as a low shoe with an opening at the dorsal side increasing from the first toe as far as the lower leg. These 3 topdermatomes present rather strong variations in shape and situation. Apparently these variations are strongest distally near the foot. We saw that the number of toes, falling inside each of these fields varies constantly. I must however point out that suchlike variations are not caused by important variations of extent. A slight variation in the extent of a sensitive field is already sufficient to bring one toe more or less within this field. An equal variation in the extent of a more proximal part of the field would make little impression. A slight shifting in the level of design before the extremity is most felt exactly at the most peripheric part of the extremity. The strongly pronounced differentiation of the shape of the extremities at the terminations is the cause of this fact.

Sacralis 1 and 2 are both again in touch with the dorsal and likewise with the ventral medianline. Sacralis 1 is especially in the distal parts very variable. The tongue that projects here at the lateral side of the extremity, can reach now as far as the calve-muscles, now as far as the calcaneum or halfway along the lateral rim of the foot, and at last even enclose the little toe. In the cases

in which I found the 4th toe inside this field, there were always variations in the plexus extant pointing to the fact that the extremity was designed postfixally. The foremost boundaryline of this field first coincided dorsally and ventrally from the medianlines for some distance with the posterior boundary of the 4th lumbarsegment. I found likewise in different cases here an overlap of about $\frac{1}{2}$ cm. These will certainly be the experiments that succeeded best. Caricature formation is, after all, likewise with segments of strychnine by no means rare.

Sacralis 2 can also send a smaller or larger slip to the upperleg.

A single word about the axile lines of SHERRINGTON called by BOLK differentiation-boundaries.

We know for certain that originally the 4th lumbarsegment and the 1st sacralsegment, have not verged to each other. The experiment taught me however, that the overlap is much stronger than was originally supposed, but the mutual overlap of succeeding segments is not so strong, that the 4th lumbarsegment and the 1st sacralsegment, between which 3 segments are lying, can originally have verged on each other.

With the thoracic lumbarsegments I found in the dorsal region overlap of every two segments that were separated in succession by another, and in the ventral region there was still overlap of 2 segments that were separated in succession by 2 other segments. Nowhere did I see 2 segments verge on each other that were separated in succession by three other segments. We know consequently for certain, that the 4th lumbarsegment and the 1st sacralsegment originally have not overlapped each other and have not verged on each other, but that there has existed between the caudal boundary of the 4th lumbarsegment and the cranial boundary of the 1st sacralsegment a zone of a certain width. After the development of the extremity these 2 boundaries of dermatomes have approached each other, and the two dermatomes between which there was originally a distance, have even for a narrow zone overlapped each other. This fact was already known from SHERRINGTON's experiments. SHERRINGTON points to the fact that the overlap at the axile lines has much resemblance to the dorsal and the ventral "crossed-overlap". About as far as the boundary between the inferior and the central part of the upperleg these two dermatome-boundaries coincide; afterwards the anterior boundary of sacralis 1 assumes a more slanting posterior direction. The superior part of the 5th lumbar dermatome reaches nearly this height, so that then the length of the axial line corresponds with the distance, along which these two dermatome boundaries coincide.

In those cases however in which the 5th lumbar segment extends farther in the direction of the vertebral column, and even crosses the region of the trochanter, the length of the dorsal axile line is thereby considerably shortened. As we saw already above, the 5th and the 6th lumbar segment at the innerside of the leg extend less far than is the case with dogs. Consequently the ventral axile-line is here longer with cats. The distinctness of the determination of the dermatomes at the innerside of the upperleg according to the strychnine-method leaves here however something to be desired. A greater extension of the tops of the 5th and the 6th lumbar segment would of course here shorten the axile-line.

In connection with this discussion of the axile-lines I want to fix here the attention to another fact that, in my opinion, is connected with the origin of the axile-lines.

The top of the 5th lumbar segment namely penetrates with a rather wide margin into the sensitive field of sacralis 1. Now it seems to me, that originally this overlap did not exist there, because 2 dermatomes that are separated by two others; do not show such an overlap in the dorsal region. Therefore it seems to me, that during the development of the extremities this overlap has come into existence secondarily; the anterior rim of the field of sacralis 1 has thereupon approached the field of lumbalis IV, and in this way a fringe of the top of the 5th lumbar dermatome has likewise been overlapped.

Shifting of the design of the hindleg.

In my material of experiments I have three times observed a postfixed design of the hindleg. In one of these cases I supposed that I found indications that would make a widening of the design of the extremities admissible.

In Fig. 3 a representation is given of the arrangement of the dermatomes of the hindleg from the dorsal side, in Fig. 4 from the ventral side (cat 32). At the boundaries of the dermatomes the order-figure of the dermatomes is given (at the lumbar segments by thick figures and at the sacral segments by thin figures). From these pictures it appears distinctly, that the 5th lumbar skin-segment takes here the place of the 4th of the average cases, the 6th that of the 5th etc. On the hindleg every dermatome has consequently shifted about the width of a segment in a frontal direction. From the investigation of the plexus Ischio-lumbalis it appeared, that here the N. Ischiadicus had originated in the 7th lumbar and the 1st sacral root, and received moreover bundles from lumbalis 6 and

sacralis 2; that further the N. Obduratorius originated from lumbalis 6 and received moreover bundles from lumbalis 5; that the N. Femoralis originated from lumbalis 5, and received moreover bundles from lumbalis 4 and 6. The 1st sacral root was a little thinner than the 7th lumbalis and thicker than the 6th lumbalis. Here we have consequently to do with a nerveplexus, as occurs at postfixure

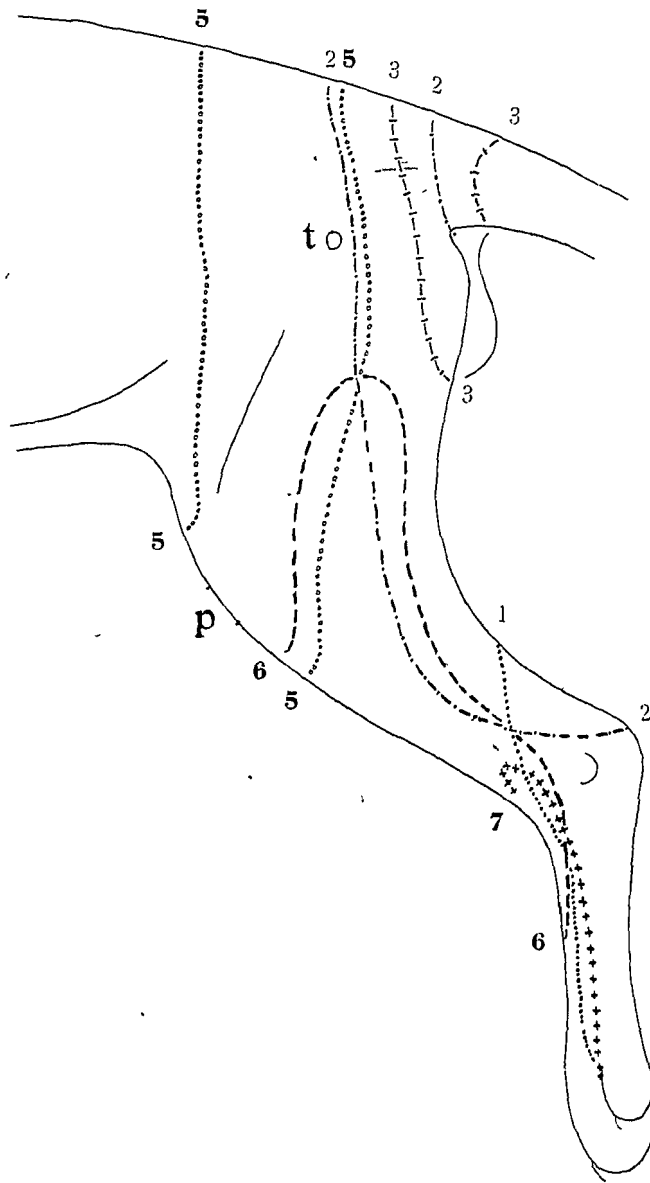

Fig. 3.

Strongly postfixally designed left hindleg of a cat. At the boundary of the lumbar segments the order-figure is indicated by a thick figure; at the sacral segments by a thin figure, *t* = trochanter, *P* = patella. For the innerside, vide fig. 4).

of the hindleg. This is entirely in conformity with the serial shifting of the dermatomes on the hindleg.

With cat 29 I found a postfixed design of the hindleg whilst a serial shifting of the dermatomes existed amounting to less than a segment. With this cat all fields have shifted in a cranial direction. The sensitive field of lumbalis 4 reaches less far than usually on the leg; the distal boundaryline crosses over the anterior rim of the leg $1\frac{1}{2}$ cm. above the patella. The top of the 5th lumbalis extends to above the trochanter, but does not reach the dorsal medianline. At the ventral side however this dermatome is in contact with the medianline. These two dermatomes point decidedly to a postfixed design of the hindleg. We see this a. o. also at the first

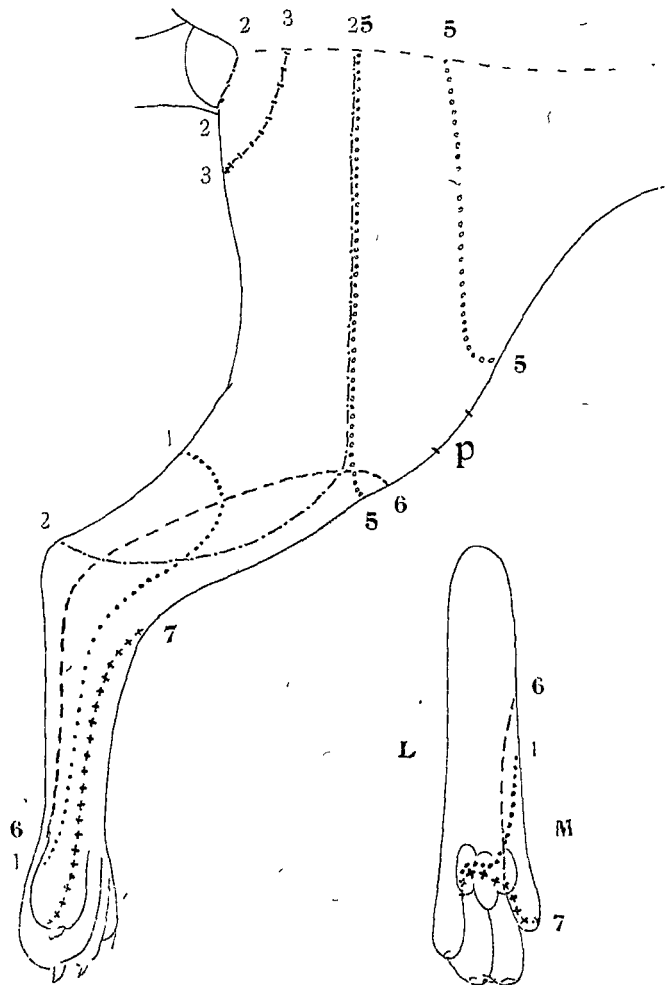

Fig. 4.

Innerside of the leg of fig. 3. Vide subscription of fig. 3. Separately is still given the planta pedis. *L* = lateral *M* = medial.

sacral dermatome, which covers the 4th toe entirely and the 3rd toe partially. We have here consequently a serial shifting of all the dermatomes, amounting to somewhat less than the width of one dermatome. The structure of the plexus pointed here likewise to a distinct, postfixed design of the extremities.

The sensitive fields of the skin of cat 35 furnished still a peculiarity which I wish to discuss here in a few words. The first sacral segment of this cat would point to a post-fixed design of the leg, whilst the 4th lumbar segment would suggest a prefixed design. The entire exterior rim of the foot and the 4th toe falls inside the field of sacralis 1. This points to a post-fixed design of the hindleg. The sensitive field of lumbalis 4 has a slip at the innerside of the leg reaching as far as the place, where the calf muscles end and the tendon of Achilles begins.

This field possesses consequently properties of the 5th lumbar segment and would point to a pre-fixed design of the extremities. The question rises, if we have here to do with a more widened design of the hindleg. With certainty I can, with the determination of these fields, exclude, that these deviations could have been caused by a not exact local moistening of the spinal cord with the solution of strychnine. I happened to determine the fields in this succession: lumb. V, VI, VII, sacralis 1 lumbalis IV. When I determined thus sacralis 1, the 3 preceding lumbar-roots had been cut, and the 1st sacral segment could consequently not obtain here the properties of the 7th lumbar-segment, because the spinal cord had not been locally moistened there. This is likewise the case with the field of lumbalis IV. When this was determined the 5th lumbarroot had been cut, and consequently the 4th lumbar segment could neither obtain properties of the 5th segment here, on account of the fact that the spinal cord had not been sufficiently locally moistened.

The 3 segments between these two fields offer few deviations.

The relations in the plexus are again of such a nature, as we find them at post-fixed design of the hindleg. The N. Ischiadicus originates again from the 7th lumbar root and the 1st sacral root, and receives likewise rootbundles from the 6th lumbalis and the 2nd sacralis. The 1st sacralroot is thicker than the 6th lumbarroot. I suppose I ought to describe this case as accurately as possible. It may be of use to continue to pay attention to the fact, that the possibility of a widened design of the extremities can exist.

WINKLER and VAN RIJNBEEK supposed likewise in 1910 in their investigations concerning the overlap of the dermatomes of the hindleg of dogs, that they had found indications of this fact.

Physiology. — *“Specific smell intensity and the electrical phenomenon of cloudlike condensed water vapours in chemical series.”*

By Prof. Dr. H. ZWAARDEMAKER.

(Communicated in the meeting of May 27, 1916).

In the meeting of the 25th of March 1916 we set forth that all true odorous substances have the property of imparting an excess of electro-positive charge to the cloudlike condensed water-vapour, generated by spraying an aqueous solution under an overpressure of two atmospheres. The attending negative charge is in the air. Contrary to this, pure water¹⁾ and aqueous solutions of salts, inodorous substances, sugars, ureum etc. sprayed in the same way, give a cloud containing both charges, which persist in the case of salts.

A screen, arranged to block the way of the spray, intercepts a very strong charge in the case of the odorous substances, but is not electrified in the case of the above-mentioned inodorous liquids, unless under special circumstances that give rise also to waterfall-electricity. Not before the screen approaches the insulated sprayer very closely, or before the surrounding air has been purposely ionized (e.g. through an electric field), does a charge appear; in the latter case, also on the distant screen. This charge is identical with the charge arising spontaneously if the water in the earth-connected sprayer had been impregnated with even the merest trace of an odorous substance.

This odoroscopic phenomenon I have correlated with:

¹⁾ Pure water, diffused through a sprayer, going obliquely upwards, gives a positively charged spray, as has been shown in experiments by P. LENARD in 1898. The amount of electricity was per gram of sprayed water 7.10^{-10} coulomb. (P. LENARD, u. Wasserfallelektricität, Ann. d. Physik (4). Bd. 47, 1915, p. 479) EVE's water-sprayer gave distinct electricity of either sign (negative to excess) only to a purposely charged electrometer. (A. S. EVE, Ionization by spraying, Phil. Mag. (6) Vol. 14 p. 382 1907). J. C. POMEROY again succeeded in catching up the positive drops while the negative electricity remained in the air. (Phys Rev. Vol. 27 p. 492, 1908). It attracts notice that he also placed the sprayer above the reservoir. In all these cases, however, very small, just noticeable quantities of electricity were dealt with (A. BECKER, Jahrb. d. Radioaktiv. u. Elektronik, Bd IX, 1912, p. 79). The electroscope (EXNER-type), used in my experiments, was not sensitive at all. The aluminium-leaves were of the usual width, but rather short. They deflected at a charge of 220 Volts 10 scale-divisions of a millimeter scale. The charges produced by the odorous clouds induced much larger; even maximal deflections within some moments. They were of the order of 100.10^{-10} coulomb per gram of sprayed solution, with an earthed sprayer.

1. molecular weight,
2. volatility,
3. lowering of the surface-tension of the solvent, the same factors being, to a certain degree, essential to render a substance odorous.

I particularly wish to lay stress on the second and the third factor by observing that odorous substances lower the surface-tension of water, that they are volatile, and that, on the contrary, not all volatile substances, lowering the surface-tension, must of necessity be odorous substances. If my view is correct we may rationally expect a relationship to exist between the smell intensity of a substance and the intensity of the electrical phenomenon. This relationship will appear in its simplest form with homologous series.

In the literature mention has been made of two homologous series that have been carefully studied as to smell intensity. They are the aliphatic alcohols to the fifth term and the fatty acids to the tenth. PASSY¹⁾ determined the smallest quantity of matter, diffused in a litre of air, capable of arousing olfactory sensation. When we divide this smallest quantity, expressed in grams by the molecular weight, the reciprocal of the number is an index for the specific smell intensity. This leads to the following results.

By plotting the molecular weights along the axis of the abscissae and the molecular smell intensities along the axis of the ordinates we get curves of a regular shape.

Likewise graphs may be made of the electrifying power of the clouds.

When we place a circular tin disc 50 cm. in diameter, in the drift of an odour-solution from an earthed sprayer, at only 1 or 2 mm.

TABLE I.
Aliphatic alcohols.

Terms	Min. perc. gr. per Litre PASSY	Mol. weight	Specif. smell intens.	Log. mol. smell intens. - 4
Methylalcohol	1000.10 ⁻⁶	32	0.032.10 ⁶	0.51
Ethyl „	250.10 ⁻⁶	46	0.18 .10 ⁶	1.26
Propyl „	10 à 5.10 ⁻⁶	60	6 .10 ⁶	2.78
Butyl „	1.10 ⁻⁶	74	74 .10 ⁶	3.87.
Isoamyl „	0,1.10 ⁻⁶	88	880 .10 ⁶	4.94

¹⁾ JACQUES PASSY. Comptes rendus 16 Mai 1892 and 1 Mai 1893.

²⁾ H. ZWAARDEMAKER in TIGERSTEDT'S Hdb. der physiol. Methodik. Bd. III, S. 57.

TABLE II.
Fatty acids

Terms	Min. perc. gr. per Litre PASSY	Mol. weight	Specific smell int.	Log. mol. smell int. - 6
Formic acid	25.10 ⁻⁶	46	1.8.10 ⁶	0.26
Acetic acid	5.10 ⁻⁶	60	12.0.10 ⁶	1.08
Propionic acid	0.05.10 ⁻⁶	74	1480.10 ⁶	3.17
Butyric acid	0.001.10 ⁻⁶	88	88000.10 ⁶	4.94
Valerianic acid	0.01.10 ⁻⁶	102	10200.10 ⁶	4.01
Caproic acid	0.04.10 ⁻⁶	116	2900.10 ⁶	3.46
Oenanth acid	0.3.10 ⁻⁶	130	430.10 ⁶	2.63
Caprylic acid	0.05.10 ⁻⁶	144	2880.10 ⁶	3.46

distance of the vertical nozzle, no charge will be generated¹⁾. An equal number of positive and negative nuclei splash against the disc and the algebraic sum of the charges is 0. On increasing the distance between the disc and the nozzle, while remaining well-insulated, the positive charge soon manifests itself, then gradually increases, until it reaches a maximum at a certain optimum. Later on it diminishes again, till it is reduced to zero, at a distance sharply defined for every substance. At this juncture we may say that all positive drops, produced in excess by the cloud, are present in or drop down from a cone whose vertex is the nozzle of the spraying tube and whose base is constituted by the part of the disc moistened by the cloud. The original negative nuclei, generated likewise by the cloud, are lost.

As soon as the spraying has become fairly continuous we may assume that on this side of the disc, placed at the critical distance, the number of positive drops that descend is equal to that of negative ones that disperse in the surrounding air, while moreover an equal number of either sign dash against the base of the cone. At some spots an excess of positive droplets is present in the cone e.g. on a small disc, when placed at a shorter distance. Besides this, continually some fall down. If we were sure to catch up all the falling droplets and to determine their aggregate weight, we should possess a simple means to estimate the charge of an odorous cloud. J. C. POMEROY²⁾, has availed himself of this artifice to detect the faint charge imparted

¹⁾ With an earthed sprayer pure water yields no charge, while with a sprayer insulated by amber it electrifies small discs.

²⁾ J. C. POMEROY, Phys. Rev. vol. 27, p. 492, 1908.

also by sprayed water to the heavier particles of a cloud¹⁾. For the present I prefer, for technical reasons, to take roughly, empirically in taking the axis of the cone for index, on the one hand because its length corresponds with the distances to which the large positive and the smaller negative ions are dashed away or rebound, when sent adrift by a constant force, on the other hand because it enables us to realize that the space is large enough to balance, at least on a distant disc, the contrast between positive and negative electricity evoked by the odorous substance.

In carrying out the experiment care was taken to allow sufficient time, for the determination of the faint charge, since it is obvious that, in view of the large size of the disc, its capacity should not be neglected, so that several seconds will elapse before a sufficient amount of electricity has been obtained to be visible on the electroscope.

The results are to the following effect:

TABLE III.

Aliphatic alcohols	Critical distance (cm.)		
	0.3 n.	0.2 n.	0.1 n.
Methylalcohol	46	26	3
Ethylalcohol	103	70	35
Propylalcohol	145	80	72
Butylalcohol	170	100	117
Isoamylalcohol	187	135	130

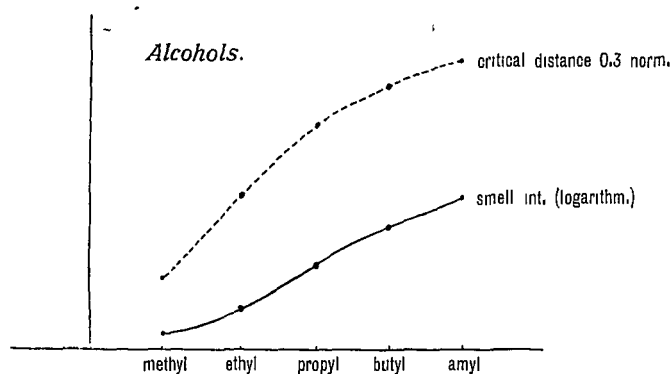

Fig. 1.

¹⁾ No manner of charge was given in our experiments by pure water under the experimental conditions, carefully observed, viz. an overpressure of two atmospheres, perfect cleanness of sprayer, glass vessels, air-chamber of 2 m³. capacity, long metallic pressurecircuit.

A combined graph of Tables I and II may be obtained by plotting the molecular weights against either the logarithms of the specific smell intensities or the critical distances. The curves will then be seen to rise correspondingly and to run roughly parallel.

TABLE IV.

Fatty acids	Critical distance (cm.)						
	$\frac{1}{10}$ norm. sol.	$\frac{1}{20}$ n.	$\frac{1}{40}$ n.	$\frac{1}{80}$ n.	$\frac{1}{160}$ n.	$\frac{1}{320}$ n.	$\frac{1}{640}$ n.
Formic acid	1.2	no charge					—
Acetic acid	20	0.5					2
Propionic acid	81	50					20
Butyric acid	125	85					74
Valerianic acid	170	173					78
Capronic acid	—	190	180	177	160	132	106
—	—	—	—	—	—	—	—
Caprylic acid ^b	—	—	—	—	—	—	90

N. B. Below $\frac{1}{40}$ n. great care has been taken to keep up the spraying precisely $\frac{1}{4}$ min.

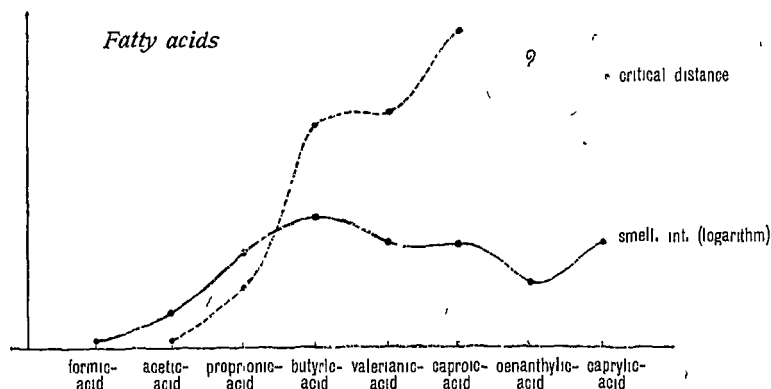

Fig. 2.

A combined graph of Tables II and IV may be obtained by plotting the molecular weights against either the logarithms of the specific smell intensities, or the critical distances. The curves thus obtained are not so regular and similar as in the case of alcohols, nevertheless they are of the same type.

Our object in doing this is to compare a physiological with a

physical property, each depending on the volatility of the substance and the capacity of lowering the surface tension of water.

Therefore it avails to measure at the same time the surface tension. In the case of pure substances it does not exert a special influence upon the shape of the curve. In the case of water it does. Mr. H. R. KNOOPS was kind enough to investigate this for the fatty acids.

TABLE V.

Number of droplets falling from TRAUBE'S Stalagmeter
the standard for water being 51.

Fatty acids	$\frac{1}{20}$ n.	$\frac{1}{40}$ n.	$\frac{1}{640}$ n.
Formic ac.	51	51	51
Acetic ac.	57	56	53
Propionic ac.	58	57	53
Butyric ac	70	68	53
Valerianic ac	88	72	53
Caproic ac.	—	72	54
—	—	—	—
Caprylic ac.	—	—	53

In the series of fatty acids about which we know most, smell intensity and electric power agree in that, while running up in the lower terms, they first increase till they reach a maximum at a certain point, then suddenly weaken in order to fade out in the end. The factor, which, as I think, dominates the olfactory and the electrifying property, viz. that of lowering the surface tension, maintains itself till the series is far advanced, for myristin acid still reduces the surface-tension distinctly (it arrests the camphor-movement and, when added to water to saturation, its number of drops in a given volume is 60, that of water being 51), but it does not evoke the electrical phenomenon, and is at the same time inodorous. It is not improbable that this has something to do with its lack of volatility. I cannot say, however, which of the two properties: the electrical phenomenon or the olfactory capacity goes farther in the homologous series, as caprylic acid was the highest term at my disposal, and this substance still evinces both properties. According to Passy lauric acid is the terminal smell stimulus in the series.

22*

Smell intensity and electric power do not reach their maximum at the same term. For the former it occurs with butyric acid, for the latter with caproic acid. A physiological property cannot, indeed, be entirely dependent on merely physical factors. Material volatility e.g. may be a matter of necessity for smell; once afloat odorous molecules are at the mercy of currents of air and diffusion. Further on, in the olfactory fissure adsorption to a moist surface is necessary, but a great number of glands cause the chemical composition of the moist layer, and consequently also the surface qualities to vary from those of water.

Finally the adhesion of the odorōus particles to the olfactory hairs is certainly a necessary condition, but the influence they exert is not determined by the degree of adsorption alone. The mere fact that the curves roughly point to such a close relation between the electrifying power and olfactory capacity is remarkable.

A more accurate quantitative measurement of the electric phenomenon may still be obtained by arranging a small disc of just the right size at the critical distance of the sprayer and by allowing the positive drops to beat against it, while the negative ions rebound and disperse. From the time required for a definite deflection, under an overpressure of precisely two atmospheres, or from the deflection brought about by a definite amount of an odour-solution, say 25 c.c., the electrifying power may directly be estimated. An inquiry is now in progress, but of course it will not enable us to point out a closer relation than has already been revealed.

The other series of substances, inodorous yet evoking an electrical charge, has in so far as I was able to ascertain, the property of being soluble in water, of lowering its surface-tension, and moreover of being sublimable. Whether with these substances (antifebrin, antipyrin, caffen, etc.) there is any relationship between the electrical phenomenon and the intensity of physiological action is a question that must be left for further investigation. Many times already experimenters have been looking for a relationship between surface-forces and physiological or toxic effects among chemically allied substances, but their efforts concerned the surface forces acting upon lipid membranes. In the case of odorous substances in an homologous series we have to do with the action of surface forces upon a capillary layer of water, which no doubt is a much simpler question.

Physiology. — “*A new group of antagonizing atoms.*” II. By Mr. T. P. FEENSTRA, assistant at the Utrecht Laboratory for Physiology. (Communicated by Prof. Dr. H. ZWAARDEMAKER).

(Communicated in the meeting of May 27, 1916.)

In a previous paper¹⁾ I have described experiments showing the property of uranium to serve as a substitute for potassium in RINGER's mixture, also when it has been freed from its transformation products. Another element of another group of the periodical system of MENDELEJEFF, viz. thorium possesses the same property.

However, with this element, the action may be provoked entirely or partially by one of the transformation products of thorium, viz. radiothorium, which has properties similar to those of thorium, so that it is impossible to remove it from this element.

My method in examining this element was that used in my uranium experiments, with this difference only that the mean temperature in the present series was 18° C.

The new fluid was prepared from potassium-free RINGER's mixture, denoted (as in our first paper) by (R—K). An average of 50 mgrms of thoriumnitrate was added per litre. A dose smaller than 40 mgrms per litre could on no account be used as it did not activate the fluid. The chances also were that by adding too much thoriumnitrate, the fluid would have a poisonous effect upon the heart; it will be seen below that when 100 mgrms was added per litre of (R—K) the circulating fluid could not make the heart resume its pulsations.

Another property of thorium had also to be taken into account, viz. thoriumnitrate will be precipitated, though slowly, as thorium-oxid in the slightly alkaline RINGER's mixture.

The fluids required for the experiment were prepared immediately before use, as we wanted all the thorium to be in solution. I also often observed that the fluid, after standing for about 24 hours, was inoperative; a residue had then been thrown down upon the bottom of the flask.

After the frog's heart, subsequently to its being tied up, had been fed with the circulating common RINGER's mixture for fifteen minutes the latter was replaced by (R—K). This circulation was continued till a standstill of the heart ensued.

The thorium-containing (R—K) was then administered, upon which the heart began to beat spontaneously and regularly, as at the beginning of the experiment.

¹⁾ Proceedings of the Kon. Ac. v. Wetensch. Vol. XIX p. 99.

Thirteen times the same result was obtained, namely just as with uranium, the heart was restored at once to its normal condition. The contractions were at once normal as to extent and frequency; the electrocardiogram also was quite normal again. There was no change of tonicity in this process.

Now we wanted to note again the behaviour of the heart when, after the circulation of the thorium-containing fluid, the common RINGER'S mixture was again allowed to run through it. It appeared that in this case a standstill ensued immediately, from which the heart recovered only when fed with (R—K) or with thorium-containing (R—K). The same phenomenon had previously been observed with uranium. For the present I take it that the accumulative effects of potassium and thorium or uranium are responsible for this standstill.

We now had to consider the possibility that activity was conferred on the thorium either through contamination with potassium or rubidium, or through its transformation products. To solve these problems the thorium was purified in the following way:

With strong ammonia the thorium was thrown out of a strong solution of thoriumnitrate, which yielded a precipitate of thorium-oxid. Any contamination of potassium or rubidium present in the thorium will remain in solution, a few traces excepted. These traces precipitated along with the thorium, cannot provoke the action, as it has been shown in our previous publication that the addition of 5 mgrms of potassium chloride per litre of (R—K) is insufficient¹⁾. This precipitate was filtered off and subsequently washed three times.

Now it was necessary to convert the thoriumoxide again into a soluble compound. It was, therefore, taken up with some water, and, while it was being warmed, dilute nitric acid was added cautiously, the reaction of the fluid being continually noted by means of small strips of litmus-paper. With a neutral reaction only an inappreciable quantity of the thorium-precipitate was dissolved. The reaction was, therefore, acidified by the addition of some more nitric acid, with the satisfactory result that a large part of the thoriumoxide was dissolved. A quantity of 2 c.c. of this fluid was now measured off, evaporated to dryness and heated till the thoriumnitrate was converted

¹⁾ Boltwood's*) experiment proved that when thorium is extracted with ammonia as a thoriumoxide residue, only radiothorium is thrown out of solution with it**). The mesothorium 1 and 2 and the thorium X remain in solution. The thorium is consequently freed from its principal transformation products, with the exception of the radiothorium.

*) RUTHERFORD in E. MARX. Hdb der Radiologie Vol. II, p. 491.

***) RUTHERFORD l. c. p. 489.

into thoriumoxide. By determining the weight of the residue we were in a position to calculate the amount of thoriumnitrate in 2 c.c. of the fluids. Thus we were enabled to add so much of the fluid to (R—K) that it contained precisely 50 mgrms of thoriumnitrate per litre.

As an addition to RINGER's mixture of a large quantity of the fluid, strongly acidified with nitric acid, would alter the reaction, which should of all things be carefully avoided¹⁾, it was essential to concentrate the fluid as much as possible. When 2 c.c. of the fluid produced a residue of about 25 mgrms of thoriumoxide, the fluid was in a suitable condition to supply the thoriumnitrate for the thorium-containing (R—K). A special investigation, in which rosolic acid was used as an indicator, taught me that the thoriumnitrate-solution should be added to (R—K) to such an amount, that the reaction of this liquid was not altered perceptibly.

The behaviour of the thoriumnitrate solution, treated in this manner, was similar to that of the thoriumcompound that had not been purified in the process of precipitation with ammonia.

It appears then that there is no question about contaminations with potassium or rubidium, and moreover that the transformation products, radiothorium excepted, cannot induce the action. It may be, therefore, that the radiothorium is the active constituent.

We have already communicated at the beginning of this paper that, if 100 mgrms of thoriumnitrate is added to (R.—K.) the fluid has a toxic influence upon the heart, through which it is allowed to pass. We now considered it essential to discover whether the toxic action could be arrested by increasing the amount of calcium. Consequently 200 mgrms of calciumchloride were added to the 100 mgrms of thoriumnitrate-containing potassium-free fluid. When a stream of this fluid passed through the heart, the cardiac action was normal, as was the case with the smaller antagonizing dose.

Thus, if the quotient

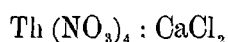

is $\frac{2}{17}$, the limit of toxicity for thoriumnitrate is passed. An addition to the (R—K) of 150 mgrms of thoriumnitrate brings the above quotient up to $\frac{1}{17}$. Another addition of 400 mgrms of calciumchloride is still required to bring about a normal action of the heart

Only thus far can the antagonism be watched experimentally. When 200 mgrms of thoriumnitrate is added to the fluid a precipitate

¹⁾ MINES. Journal of the Marine biological Association, Vol. IX, No. 2, 1911.

of thoriumoxide will be formed after some minutes, so that most of the thorium will be thrown out of solution.¹⁾

The other elements of this group of the periodical system yield, even in small quantities, an intense deposit in RINGER's mixture. This indeed could be helped by changing the reaction of the fluid, but we know that by changing the hydrogen-ions-concentration RINGER's mixture is rendered very poisonous for the heart. I regretted, therefore, not to be able to extend my experiments to these elements. Only thoriumnitrate forms a favourable exception as the precipitate appears only after quite a long interval when 50 mgrms of thoriumnitrate are added to (R.—K.).

CONCLUSION.

Just as RINGER demonstrated with respect to rubidium we have proved, in our communications, that uranium and thorium can take the place of potassium in LOCKE-RINGER's solution:

Either element appeared to be antagonistic also to calcium, a property assigned by RINGER to potassium and rubidium. The same researcher also recorded that calcium may be substituted by strontium as regards its antagonism for potassium.

Mr. JOLLES proved the antagonism of strontium to uranium and thorium.

LOEB attaches importance to the valency of ions in the antagonism of the salts. In the case of uranium I was able to show that the valency is of no consequence. The only condition to be fulfilled was the presence of the uranium atom. In the case of thorium I was not able to ascertain this, having no compounds at my disposition, in which the cation is of different valency.

¹⁾ Mr. JOLLES investigated the antagonism of thorium for strontium, as had been done with uranium. He stated that the toxicity of the thorium in RINGER's mixture is obviated by strontium, 250 mgrms of strontium chloride being an equipoise for 50 mgrms of thoriumnitrate.

Astronomy. — “*On a peculiar anomaly occurring in the transit-observations with the Leiden meridiancircle during the years 1864—1868.* By E. F. VAN DE SANDE BAKHUYZEN and J. E. DE VOS VAN STEENWIJK.

(Communicated in the meeting of June 24. 1916.)

1. *Introduction.*

Not many years after the mounting of the meridiancircle at the Leiden-observatory and the completion of a number of auxiliary apparatus according to designs by KAISER a beginning was made with the observation for an extensive Fundamental Catalogue. For this purpose a list of 166 stars was drawn up (mainly the list of the Nautical Almanac as far as visible at Leiden) containing 24 circumpolar stars which were to be observed in both culminations. The observations began in February 1864 and were considered as completed in July 1868. The number of observations had been 15870 of which about 12800 pertained to the fundamental stars and 579 to the sun.

All these observations were published — although for the greater part unreduced — in 1868 in the Annals of the observatory, Vol. I. Soon afterwards, however, a beginning was made with the reduction of a limited number of the declination-observations, and this reduction, with a full discussion of the results, which gave rise to important investigations by KAISER and his collaborators, appeared in 1870 in Volume 2. A complete reduction was even then designed, but — apart from an addition to the results of Vol. 2 according to calculations by Dr. VALENTINER — it was not till 1876 that the project, including a complete reduction of all the declination-observations of the fundamental stars and of the sun, was actually taken in hand. In 1879 the work was for the main part completed and a short account of it was given by the first of us in his thesis for the doctorate published in the same year containing a determination of the Obliquity of the Ecliptic according to the Leiden declinations of the sun. The complete reduction of the declination-observations of the stars was then published in 1890 in Vol. 6 of the Annalen, the discussion of the final results, although for the greater part completed even then, has not yet been published.

Whereas the reduction of the declination-observations of the years 1864—1868 had thus been completed within a comparatively short period, the observations of the right-ascensions on the other hand remained for the greater part unreduced. Apart from the reduction

of the observations of planets and comparison-stars, we can from the years following only record a reduction carried out by KAISER and published in Vol. 2 of the *Annalen* of the transit-observations made in September 1868 for the purpose of the longitude-determination with Brussels. In this paper KAISER gave a number of important remarks on the reduction-elements of the meridian-circle, but at the same time he showed that the observations proved an anomalous behaviour of the collimation-constant, which could not be explained at the time.

Some years later the first of us investigated for the Leiden meridian-circle the influence of an eccentric illumination of the field of the telescope, a question which was much discussed at the time and which, although very simple and although the true nature of the disturbance originating from it, when the adjustment of the ocular is incorrect, had been made clear by CARLINE half a century before, had raised a considerable amount of dust. With different positions of the ocular pointings were made on one of the meridian marks, using for the bisections the apparent position of the micrometer-thread outside the mark; for on the mark the central illumination by the mark itself exceeds the eccentric field-illumination and that part of the thread is always seen in its true position. From the variations of the readings for different positions of the ocular it was possible to deduce the position of the mirror in the cube of the telescope which reflected the light for the illumination of the field and, on the instrument being dismounted in 1876, the actual position of the mirror was found to agree exactly with the calculation. In the alterations of our meridian-circle carried out by REPSOLD in 1876—77, amongst other things the field-illumination was modified and made exactly central.

These results naturally suggested to E. F. B., that the disturbance of the collimation-constant occurring in September 1868 would find its explanation in the same phenomenon. The sign of the error arising from it, like the influence of a normal collimation-constant, must change on reversal of the instrument and one would have to suppose, that in the observations for the longitude-determination, especially those of the pole-star, (all transits were at that time observed by the eye-and-ear-method) the ocular had been pushed in too far. This did not appear improbable in itself, as the thread seemed if anything to become even a little finer, when the ocular was pushed in a little too far.

It thus became the question, whether disturbances of that kind had to be suspected during the whole of the period 1864—68. In

that case the computation of the absolute azimuth especially would become much more difficult and the importance of the observations for the determination of absolute Right-Ascensions might perhaps be materially reduced. Fortunately a few years later in 1882, when the first of us at the request of NEWCOMB undertook a revised reduction of the Leiden observations of Mercury, which naturally involved some investigations, albeit provisional ones, on the instrumental constants, it was found that during the whole period of the Fundamental Observations 1864—July 1868 somewhat considerable influences of the eccentric illumination could not be detected.

The old series of fundamental R. A. observations thus continued fully to deserve an accurate systematically planned reduction and discussion, but the great extent of the work was gradually giving rise to the fear that it would hardly be undertaken any more, when last year the second of us resolved to undertake the task, at least for an important part, notwithstanding the considerable difficulties arising from the present circumstances which compel him to reside outside Leiden.

The working plan to be followed was then agreed upon by us. The main object would be, assuming the relative R. A. of the fundamental stars as given by AUWERS's New Fund. Cat. or by that of NEWCOMB, to deduce from the observations of the sun a new determination of the Equinox for 1865. The declination-observations of the sun, as recalled above, had already been discussed by the first of us a long time ago, and consequently by this procedure data would be obtained regarding the advantages and disadvantages of the method of separate treatment of the two coordinates of the sun.

The work proper would be preceded by a new and rigid investigation of all the reduction-elements and all errors and peculiarities of the instrument and the observers, for which purpose the investigations formerly instituted at Leiden could serve as a first approximation, and the results of two special investigations regarding the value of the divisions of the level used and the irregularities of the pivots could immediately be utilized.

In the first volume of the *Annalen* the means of the times of transit reduced to the middle thread are given for all the observations, while in the introduction on page LXXXVIII are mentioned the values of the thread intervals which were used in the reduction, the total period having been divided into six parts, for which different values were assumed. It soon appeared to us, however, that in view of the degree of accuracy now aimed at, and the fact that

the times of transit of each of the sun's limbs are usually based on not more than three threads a closer investigation into this question would also have to be instituted beforehand. During this investigation a peculiar anomaly showed itself, the true nature of which was at first not recognized by us for a long time and, as a similar anomaly may also have occurred in other series of eye-and-ear-observations, it seemed to us of some importance to make a separate short communication on this point.

2. *Deduction of the thread intervals. Peculiar divergences in the observation of the transits.* -

The reticule of the meridian-circle at that time contained 7 vertical threads. It is probable, that special not very extensive series of observations were carried out each time to deduce the thread-intervals, as given in volume I, although sometimes the method of deduction followed is not quit clear. The motives for the separation of the periods are not always equally clear either. Sometimes some perturbation had taken place or the reticule had been cleaned, but in one case at least, that of the separation of the 6th from the 5th period, the ground for it cannot be recognized in the least.

However that may be, it seemed to us necessary to investigate the matter more closely by testing the intervals assumed each time on large numbers of transits of the fundamental stars observed, using the results of both observers and also, as much as possible, those obtained in both positions of the instrument designated in Leiden as clamp East and clamp West. In later years it had appeared at Leiden again and again, that small systematic differences may occur here dependent upon observer and position of the instrument.

Using the times of transit reduced with the thread-intervals as assumed before, for each observation the differences middle thread — side thread were formed, which we shall call $[\Delta]$. Further calling the corrections of the distances assumed for the threads I to VII (I is the one nearest the clamp) $\Delta I, \Delta II$, etc., if there are no disturbances, we must have

<i>Thread</i>	<i>Clamp West</i>	<i>Clamp East</i>
I	$[\Delta] = + \Delta I$	$[\Delta] = - \Delta I$
II	„ $+ \Delta II$	„ $- \Delta II$
III	„ $+ \Delta III$	„ $- \Delta III$
V	„ $- \Delta V$	„ $+ \Delta V$
VI	„ $- \Delta VI$	„ $+ \Delta VI$
VII	„ $- \Delta VII$	„ $+ \Delta VII$

In that case, i.e. if the times of transit over all the threads are estimated in the same way, independently of their position and order, the condition for each thread would be:

$$[\Delta] \text{ Cl. West} + [\Delta] \text{ Cl. East} = 0.$$

It was already mentioned, that more than once at Leiden systematic differences were found, so that this relation did not hold accurately. Such differences have especially occurred with the extreme threads and are most probably due to the first thread being observed in an abnormal manner (we are referring here to chronographic observations). Hereby the sums for the two extreme threads became different from zero by the amount of the anomaly. As an instance, in Dr. PANNEKOEK's observations of the years 1899—1902 the sums for the extreme threads were -0^s032 and -0^s035 respectively, whereas for the other threads the greatest value of the sum was 0^s025 , and as a rule it was much smaller.

In the present investigation of the thread-intervals we confined ourselves to such stars as had been observed on all 7 threads and even with this restriction, at least for the four largest periods I, II, V and VI, abundant material was available. As in this communication it is our object more especially to bring forward some general conclusions, we shall exclusively investigate the results of those 4 periods which are the only ones suitable for that purpose. We shall not communicate the results as originally derived, but immediately apply two special modifications which were found to be advisable to the second of us in the course of a preliminary investigation. These modifications consist in the first place in confining ourselves to such stars as were observed *during the night* and had also been observed *in declination*, and secondly in dividing the V_{th} period into two sub-periods Va and Vb, the division being formed by a cleaning of the reticule on January 29, 1866. Although it appeared later on that Vb and VI could be united, we shall for the moment keep these periods separated.

As mentioned above, for each observation the quantities $[\Delta]$ were formed and subsequently the sums $[\Delta]_w + [\Delta]_E$, when the totally unexpected results were obtained which are contained in the following table. The quantities are expressed in thousandths of a time second, the number of observations used in each position being added each time.

The sums will be seen to reach unexpectedly large values and to be roughly the same for all threads and also for both observers. A considerable part of the oscillations which appear may be ascribed

SUMS $[\Delta]_W + [\Delta]_E$

Observer KAM.

	Period I	Period II	Period Va	Period Vb	Period VI	Mean II to VI
Numb. of obs.	94—113	58 42	62 100	270—333	136 132	
Thread I	—49	— 93	— 90	—103	—79	— 91
" II	—44	— 74	—102	—102	—78	— 89
" III	—19	—100	— 76	— 89	—33	— 74
" V	— 2	—104	—103	— 88	—99	— 98
" VI	—40	—116	—129	—116	—91	—113
" VII	—34	—124	—145	— 92	—95	—114
1st Half	—37	— 89	— 89	— 98	—63	— 85
2nd "	—25	—115	—126	— 99	—95	—108
Together	—31	—102	—108	— 98	—79	— 97

Observer v. HENNEKELER.

	Period I	Period II	Period Va	Period Vb	Period VI	Mean
Numb. of obs.	148—166	58—90	173—175	225—187	111—73	
Thread I	— 70	— 54	— 87	— 74	— 46	— 66
" II	— 71	— 86	—109	— 64	—46	— 75
" III	— 94	— 72	—101	+ 11	—31	— 57
" V	— 98	— 50	— 87	— 49	—24	— 62
" VI	— 86	—103	—135	—136	—98	—112
" VII	—104	— 85	—130	—103	— 73	— 99
1st Half	— 78	— 71	— 99	— 42	—41	— 66
2nd "	— 96	— 79	—117	— 96	—65	— 91
Together	— 87	— 75	—108	— 69	—53	— 78

to the accidental error of the observations. The investigation of the thread-intervals namely gives $\pm 0^s141$ as mean error of a transit over one thread for KAM and $\pm 0^s131$ for HENNEKELER, and thus as that of a thread-interval for K. $\pm 0^s200$ and for H. $\pm 0^s185$,

for a value of $[\Delta]$ deduced from 100 observations the m.e. is thus for $K \pm 0.020$, for $H \pm 0.018$ and for a value of $[\Delta]_W + [\Delta]_E$, if in each position of the instrument 100 observations are used, it is for $K \pm 0.028$ and for $H \pm 0.026$.

Notwithstanding the pretty considerable m.e. the following facts stand out clearly. For KAM in the first period, i.e. in 1864, the sum $W + E$ was relatively small -0.031 , whereas in the following years it remained very constant at about -0.097 . For HENNEKELER no distinct change can be seen, the mean value for him is 0.078 and therefore possibly a little smaller than K.'s value in 1865-68. Moreover for both observers the value may be somewhat larger for the threads V-VII than for the threads I-III.

However that may be, the chief result is undoubtedly the constant amount for all the threads. The cause of this had to be inquired into, in order thereby to deduce the influence on the determination of the thread-intervals. The value being as large as it is, it was not allowable without further investigation to take for the correction of the thread-intervals the mean of the results in the two positions. Before proceeding, however, the meaning of the results obtained may first be established. They depend upon the corrections which the intervals previously assumed require, and therefore also upon those former values themselves. The question might therefore arise, whether the anomalies found above, i.e. the values of the sums as differing from zero, may not have their origin in the results of the original investigation and therefore in the nature of the material used at the time. But it will be seen at once that this cannot be the case, e.g. thus: whereas before the reduction was made with one definite set of distances, errors in it cannot give rise to the differences between the corrections now found in the positions Cl. E. and Cl. W.

At the same time, although no conclusion may be drawn from the fact that at present stars were used which were also observed in declination and formerly stars, observed in R. A. alone, still it could not but appear at once probable, that the anomaly found would be connected with the bisection by the horizontal thread (the material originally used by the second of us also consisted, for the great majority, of stars observed in decl.) and it was then natural to look for the cause in a peculiar personal error of the kind as was previously shown to exist in the observations of the first of us, namely that after bisecting the star, probably owing to the diminished brightness, the times of transit were observed later. The retardation in his case amounted to about 0.03 .

If we now assume, that the bisection, which with a very few

exceptions took place in the immediate neighbourhood of the middle thread, always took place beyond it, calling the change in the personal error by the bisection Δ' , such that a positive value means an accelerated observation, we shall have :

<i>Thread</i>	<i>Clamp West</i>	<i>Clamp East</i>	$W + E$	$\pm \frac{W-E}{2}$
I $[\Delta] =$	$+\Delta I$	$-\Delta I + \Delta'$	$+\Delta'$	$\Delta I - \frac{1}{2}\Delta'$
II	$+\Delta II$	$-\Delta II + \Delta'$	„	$\Delta II - \frac{1}{2}\Delta'$
III	$+\Delta III$	$-\Delta III + \Delta'$	„	$\Delta III - \frac{1}{2}\Delta'$
V	$-\Delta V + \Delta'$	$+\Delta V$	„	$\Delta V - \frac{1}{2}\Delta'$
VI	$-\Delta VI + \Delta'$	$+\Delta VI$	„	$\Delta VI - \frac{1}{2}\Delta'$
VII	$-\Delta VII + \Delta'$	$+\Delta VII$	„	$\Delta VII - \frac{1}{2}\Delta'$

By a change in the personal error after the bisection the sum $W + E$ thus obtains a constant value differing from zero for all the threads and our result might be explained by assuming that after the bisection H. estimated the times of transit $0^s.08$ too late, K at first in 1864 $0^s.03$, later on $0^s.10$ too late. The signs as found are such as might be expected according to the suggested explanation, whereas, if we assume that the bisection was made before the middle thread, our result (see the discussion further down) would mean an accelerated observation in consequence of the bisection. To begin with, therefore, the above supposition appeared to us a very probable one, but on further consideration we hesitated to adopt it definitely, especially in view of the relatively large retardation which would have to be assumed and the great influence which the retardation, as shown by the last column of the table, exercises on the derivation of the intervals themselves. For the quantities $\pm \frac{1}{2}(W-E)$ (+ for threads I—III and — for V—VII), which in normal observations immediately give us the corrections of the thread-intervals, must now be corrected by half the retardation and, by working out the more general supposition that in p cases the bisection was made before and $1-p$ cases after the middle thread, it appears that the value which will be found for the retardation itself entirely depends on the supposition made as to the moment of the bisection. The result from the general supposition is given in the following table :

<i>Thread</i>	<i>Clamp West</i>	<i>Clamp East</i>	$W + E$	$\pm \frac{W-E}{2}$
I $[\Delta] =$	$+\Delta I - p\Delta'$	$-\Delta I + (1-p)\Delta'$	$(1-2p)\Delta'$	$+\Delta I - \frac{1}{2}\Delta'$
II	$+\Delta II$ „	$-\Delta II$ „	„	$+\Delta II$ „
III	$+\Delta III$ „	$-\Delta III$ „	„	$+\Delta III$ „
V	$-\Delta V + (1-p)\Delta'$	$+\Delta V - p\Delta'$	„	$+\Delta V$ „
VI	$-\Delta VI$ „	$+\Delta VI$ „	„	$+\Delta VI$ „
VII	$-\Delta VII$ „	$+\Delta VII$ „	„	$+\Delta VII$ „

The thread-intervals must therefore in each case be corrected by half the amount of the retardation (or acceleration), but the retardation itself cannot be determined, not even as to its sign, without making arbitrary suppositions, and, if in half the cases the bisection was made before m and in the other half after m , the retardation has no influence on $W + E$ and remains completely indeterminate.

We had thus come to the conclusion, that it would be hardly possible, even from the large material of fundamental stars, to derive accurate values for the reduction to the middle thread, when we discovered that in the last two periods a considerable number of transit-observations were available, which were not combined with observations of declination and which might throw light on the problem before us. A separate investigation of these observations not only revealed the true nature of the anomaly, which appeared to be entirely different from our former supposition, but at the same time showed that its influence could also be completely, or at least for by far the greater part, eliminated in the remaining periods. This investigation may be now detailed.

As already mentioned, it had been found that neither a priori nor a posteriori any ground existed for separating the two periods Vb and VI. For the period Vb the corrections to be applied to the provisional intervals V had been calculated, but naturally from these could be derived those other ones which would have been found, if the preliminary intervals VI had been used as the basis.

The observations of non-bisected stars in the now extended period VI, Jan 1866—1868, may be divided into 4 classes. (1) fundamental stars 1866—April 1867, (2) fundamental stars April 1867—1868, (3) stars observed in 1867 which had been used in the longitude-operations with Göttingen, (4) observations for the determination of the longitude Leiden—Brussels. Each class comprises between 50 and 100 observations in each position of the instrument for each of the two observers. The longitude-determination with Brussels was,

23

however, carried out by KAM alone and the Göttingen-stars were only observed in the position clamp West. For this reason it was ultimately considered advisable not to use the last-mentioned set. We begin by giving the values of the half sums $\frac{1}{2}([\Delta]_W + [\Delta]_E)$ it will appear immediately, why we now divide by two.

$\frac{1}{2}([\Delta]_W + [\Delta]_E)$. Non-bisected stars.

Thread	Observer KAM				Observer HENNEKELER		
	1866-67	1867-68	L. Brussels	Mean	1866-67	1867-68	Mean
I	-14	-22	+6	-10	+10	-10	0
II	+2	-8	-24	-10	-2	+8	+3
III	+2	-12	-20	-10	+8	+22	+15
V	-20	-15	-28	-21	0	+12	+6
VI	-9	-14	-18	-14	+4	-22	-9
VII	-16	-11	-33	-20	+4	-19	-8
Mean	-9	-14	-20	-14	+4	-2	+1

It appears, that with HENNEKELER the observation of all the threads was accomplished without any abnormality; with KAM an anomaly seems to show itself, particularly in the later observations, in the same sense as for the bisected stars, but of a much smaller amount. It is therefore very probable, that in this case the combination of the two positions of the instrument will yield practically correct thread-intervals. By taking the mean of the results Cl. W. and Cl. E., i.e. by forming the half-differences $\pm \frac{1}{2}([\Delta]_W - [\Delta]_E)$, the following results are obtained:

Corrections to the preliminary thread-intervals VI according to the non-bisected stars.

Thread	Observer KAM				Observer HENNEKELER			$\frac{K+H}{2}$
	1866-67	1867-68	L. Brussels	Mean	1866-67	1867-68	Mean	
I	+36	+24	+28	+29	+9	+6	+8	+18
II	-24	-2	-12	-13	-46	-26	-36	-24
III	-10	-34	-50	-31	-24	-20	-22	-26
V	-4	+26	+19	+14	+19	+5	+12	+13
VI	+12	+40	+24	+25	+38	+38	+38	+32
VII	0	+29	+10	+13	+38	+14	+26	+20

As the table shows, the final results for the two observers agree mutually within the limits of the errors of observation; this proves again that the results obtained by this method must be fairly accurate.

We may thus use these results for the purpose of subtracting from the total values of $[\Delta]$ found for the "bisected night-stars" those parts $[\Delta]_1$, which depend upon the thread-intervals and thus obtaining for the two positions of the instrument separately the portions $[\Delta]_2$, which are the consequences of the disturbance. The results are given in the table below. The results for the threads I to III and V to VII respectively have been combined, but the two sub-periods Jan. 1866—April 1867 and April 1867—July 1868 have still been kept separate.

	Values of $[\Delta]_2$					
	Clamp East			Clamp West		
	66-67	67-68	Together	66-67	67-68	Together
	Observer KAM					
Threads I—III	—33	—34	—34	—65	—29	—47
„ V—VII	—25	—35	—30	—74	—60	—67
Together	—29	—34	—32	—70	—45	—57
	Observer HENNEKELER.					
Threads I—III	—19	—31	—25	—23	—10	—17
„ V—VII	—63	—41	—52	—33	—24	—28
Together	—41	—36	—38	—28	—17	—22

The table shows that, contrary to what was originally supposed, it is not the times of transit over the second half of the reticule only that are abnormal, but that for *all the side threads* the distances from the middle thread show a deviation of approximately the same amount in the same sense, i.e. so that the side-threads appear all shifted to the same side. If this be the case, it is undoubtedly simplest to suppose, that the observed time of transit over *the middle thread itself was disturbed*.

This thread would have been observed

by KAM	in 1866—67	0 ^s 050 too early
	in 1867—68	.040 „ „
	On the average	0 ^s 045 „ „
by HENNEKELER	in 1866—67	0 ^s 034 „ „
	in 1867—68	.026 „ „
	On the average	0.030 „ „

23*

Independently of whether the amounts of the disturbances for all the threads be equal or not, they are now given by $\frac{1}{2}([\Delta]_W + [\Delta]_E)$, and not as in the previous supposition by the sums themselves, so that smaller, i.e. less improbable values may now be ascribed to them, but we may go farther and conclude that it is most probable, that an abnormality in the observation of the middle thread has been the main cause of the anomaly found. This we may perhaps imagine as having occurred in the following manner. With eye- and ear-observations the observer forms a mental image of the position occupied by the star at the last preceding second. While his attention is now partly occupied by the bisection, it is possible that this image is derived from too late a moment and this would lead to too early an estimate of the time of transit.

If the abnormal observation of the transit over the middle thread is the only source of disturbance, the expression $\pm \frac{[\Delta]_W - [\Delta]_E}{2}$ must give us the true values of the thread-intervals with the bisected stars also. This may first be tested with the stars in the same period VI, which were also observed in declination.

Corrections to the preliminary thread-intervals VI according to the bisected stars.

Thread	KAM			V. HENNEKELER			$\frac{K+H}{2}$
	1866-67	1867-68	Mean	1866-67	1867-68	Mean	
I	+ 6	+26	+16	+24	+23	+24	+20
II	-30	-24	-27	-17	-11	-14	-21
III	-56	-26	-41	-44	-14	-29	-35
V	+28	+24	+26	-24	- 8	-16	+ 5
VI	+53	+38	+46	+ 2	+27	+14	+30
VII	+58	+40	+49	+42	+20	+31	+40

Here and there (with threads V and VI) it might look as if systematic differences exist between K and H , but on comparing the results obtained with those derived from the non-bisected stars, this becomes very doubtful and the final results from the two series are in very good agreement with each other.

This is highly important, as we may now expect, that in the other periods which contain but few non-bisected stars the values of $\frac{[\Delta]_W + [\Delta]_E}{2}$ for the bisected stars will represent the deviation in observing the middle thread, and further, that other disturbances are small and that the half-differences $\pm \frac{[\Delta]_W - [\Delta]_E}{2}$ will give us the true thread-intervals. The values of the deviations for the periods I, II and Va are found immediately by taking half of the values given before (page 350). As regards the first period we may, however, utilize another important series of observations, which has not been discussed so far, namely those of stars *observed in the day time and also observed in declination*; observations of that kind occur in fairly considerable number during this period (K. E. 79, K. W. 61, H. E. 82, H. W. 103). They give the following results, where for the sake of comparison those according to the night-observations have been added.

Period I. Deviation of the Middle thread.

Thread.	KAM.		HENNEKELER.	
	Day	Night	Day	Night
I to III	— 9	— 19	— 31	— 39
V to VII	— 19	— 13	— 46	— 48
Together	— 14	— 16	— 39	— 44

Corrections to the thread-intervals.

Thread.	KAM	HENNEKELER	$\frac{1}{2} (K + H)$	Night observ.
I	+ 37	+ 8	+ 22	+ 28
II	+ 2	— 21	— 10	+ 3
III	+ 13	— 8	+ 3	+ 6
V	— 44	— 38	— 41	— 34
VI	+ 10	+ 24	+ 17	+ 14
VII	+ 16	+ 31	+ 24	+ 30

It appears from the tables, that the agreement between the results from day- and night-observations is in every way satisfactory. Both as regards the deviation and the thread-intervals it is closer than might have been expected. Where before for KAM the deviation was

found much smaller in the first period than later on, the day-observations give again the smaller value, and we may thus assume with great probability, that in 1864 this deviation must have been smaller for him than in the later periods.

The very closè agreement between the results of the day- and night-observations is of great importance from another point of view, as it proves, that an influence of the *eccentric field illumination* cannot be present to an appreciable amount in these observations. In examining this effect it is found, that it cannot be exactly the same for all the threads. Towards the side of the illuminating-mirror in the cube the effect becomes smaller, to the other side it increases, and the thread-intervals must therefore be found *too small* or *too large* on both sides of the middle. The former will occur with the ocular pushed in too far and this independently of the side from which the field-light comes. In the original arrangement of the Leiden-instrument the direction of incidence of the field-light, which came from the side of thread VII, made in the middle an angle of $2^{\circ} 20'$ with the optical axis. At the extreme threads on both sides this angle was $14'$ smaller or larger and here the relative effect was therefore 10% of the total effect at the middle thread.

If the absolute effect for the middle tread was $2''.0$ (corresponding to the ocular being pushed in too far by 0.6 mm.), as must have been the case in the longitude-determination with Brussels, the relative effect for the extreme threads is found to be $0''.2 = 0''.013$, which is just observable. By a comparison of the results *Cl.E.* and *Cl.W.* the effect cannot be revealed; that of the results of day-and-night-observations in period I shows, that, in accordance with what was derived from other facts, it was probably inappreciable.

Our investigation thus makes it extremely probable, that the observers KAM and HENNEKELER in observing the stars which they observed also in declination, made an abnormal estimate of the time of transit over the middle thread, in exactly the same way in observations in the day-time as at night. Taking this into account very accurate values for the thread-intervals may be derived from their observations. The changes which have occurred in these intervals in the course of 5 years 1864—68 are found to be small as a rule, particularly in the case of the middle thread, notwithstanding frequent catching of the movable thread, by which the point of coincidence sometimes changed considerably.

We subjoin the amounts found for the deviation in the transit over the middle thread for the various periods.

Deviation of the Middle thread.

	KAM	HENNEKELER
Period I	— 15	— 42
II	— 51	— 38
Va	— 54	— 54
VI	— 45	— 30

For KAM the value is distinctly smaller in the first period, whereas in the case of HENNEKELER there is no distinct evidence of a change.

Physics. — *“The Increase of the Quantity a of the Equation of State for Densities Greater than the Critical Density”*. By Prof. J. D. VAN DER WAALS.

(Communicated in the meeting of June 24, 1916).

Already in 1873 when drawing up the equation of state I realised that it must follow from the derivation from the kinetic theory that the quantity b would have to decrease with diminishing volume. Accordingly I stated explicitly already then that b , which represents 4-times the molecular volume at infinite volume, would have to decrease. Afterwards I came to the opinion that it would have to diminish to twice that volume, or even to a still smaller value. And that b decreases is pretty generally accepted at present. The cause of this decrease is, however, in my opinion, often sought in a wrong direction, namely in the real diminution of the molecule. I will not return to this point at present. Not until 1910 did I express my doubt of the invariability of the quantity a (These Proc. XIII p. 107). I ascribed the variation of this quantity to what I called then: “quasi association or molecule complexes”. That I looked for the cause for this increase of a in what acts as an enlargement of the molecule, as is the case for real association, I still consider correct. But I treated these possible complexes approximately as if we had to do with real association, this I should certainly not do now. In subsequent calculations in the course taken then I became more and more convinced that the result could not be valid even as an approximation. And in the following pages I will unfold the idea, which has more and more forced itself upon me, according to which the cause for this increase of a must be sought without molecule complexes being necessary, but as a consequence of the ordinary regular molecular movement of molecules which have

extension. So long as the distance of the molecules is great enough to allow the passage, a does not change, or inappreciably little, and when the mean distance is small enough to prevent this passage, there is a reason to cause appreciable increase of a . To show this in a simple way, and render the calculations possible I shall consider the molecules, even the more complex ones, as spheres. The rapid revolution, in which the axes of the molecules will assume all possible directions in an exceedingly short time is the cause that they may be considered as bodies for which no direction can be given in which the dimension is greater or smaller than in other directions.

Let us put the radius of such a sphere $= r$, and the diameter $= 2r$, the distance of the centres being represented by $2r + l$, then the case for which $l = 2r$ will have to be considered as transition case. If $l = r$, then the space available for a molecule for its movement is a space equal to 8-times the volume of a molecule. And as 4-times this volume is represented by b_η , the volume occupied by the substance is for this transition case, equal to $2b_\eta$. Now it is remarkable that this case occurs, either entirely or all but entirely, at the critical volume. My earlier considerations have made me find $v_k = 2,2b_k$ for the critical volume. But for b_k I had found almost $b_k = 0,9b_\eta$, hence $v_k = 1,98 b_\eta$. We shall not make an error of any importance if we change the value 1,98 into 2. And this may even possibly be quite accurate, but at the moment I will not enter into this any further.

If $l > 2r$, two molecules can never be touched at the same time — only when departures from the normal state occur, this simultaneous contact can take place, but then this deviation would be replaced by an opposite one at other places. The assumption of complexes also implies departures from the normal state, and I will now try to demonstrate that the increase of a at greater densities already follows on the supposition that the distribution of state is perfectly normal.

And I will account for it by this that according as the density increases, a greater number of molecules has *simultaneous* contact. The function of force for the attraction of the molecules is not known, and I have seen when drawing up the equation of state that it need not be known. For material points and for molecules in comparatively large volume the resulting attraction may be brought in the form I have chosen, viz.: $\frac{a}{v^2}$. A posteriori I found by comparison of the capillary constant with the constant of the molecular pressure that the attraction seems to exist only at the impact

of the molecules against each other (cf. Continuität p. 110). If we accept this as perfectly correct, it follows from this that when the distance of the molecules is so great that double contact never takes place, the value of a remains the same, but that increase of a will be found when this double contact takes place. If this is not entirely true, the following calculation will only be an approximation. The idea that the collisions of the molecules are in close connection with the attraction, which is expressed at the cited place, will therefore be used here to calculate this increase of a .

Let us draw three circles of equal size representing spherical molecules, with a radius $= r$. The two first circles have their centres at the same level, and are at a distance from each other $= 2r + l$ ($l < 2r$). The third circle represents the molecule moving from above downward. If we suppose for a moment that this third molecule moves just halfway the molecules A and B , and that the distance of these molecules is $2 \times \frac{l}{2} = l < 2r$, it will touch the two molecules exactly at the same time. Then there is formed a triangle, the vertex of which is the centre of the third molecule. The height PO is

$$\sqrt{4r^2 - \left(r - \frac{l}{2}\right)^2} \quad \text{or} \quad \frac{h}{2r} = \sqrt{1 - \left(\frac{r + \frac{l}{2}}{2r}\right)^2},$$

which is only equal to zero, when $\frac{l}{2} = r$, and the two molecules A and B are at a distance from each other equal to $2r$, large enough to allow free passage to the moving molecule. If $\frac{l}{2} < r$, then double contact takes place in points lying halfway on AP and BP .

If a line is erected normal to AB and passing through these points, this line may be considered as the projection on the plane ABP of the boundary of the surface of the molecules of points, in which the ordinary value of a is exerted, and of such points in which an increased value is exerted. Both on A and on P this boundary is a circle, which cuts off a spherical segment. Let us call the thickness of that segment x , then:

$$r - x = \frac{r + \frac{l}{2}}{2}$$

or

$$\frac{x}{r} = 1 - \frac{r + \frac{l}{2}}{2r} = 1 - \left(\frac{v}{v_0}\right)^n$$

We shall speak about the value of μ presently.

We may also write: $\frac{a}{r} = \frac{1}{2} - \frac{l}{4r}$.

From this we see that the greatest thickness of the segment is equal to $\frac{r}{2}$, and that it only exists for $l=0$; it would, therefore, be found if the liquid state could still exist at the absolute zero. Further that the mean thickness of the segment is equal to the mean value of the fourth part of l , and as l , and also r , hence also v , is determined at given temperature, also the segment, and therefore also a , is determined.

Of the boundary of the said segment we have as yet only accounted for the point that lies halfway AP . To find also the other points we must make the line AP revolve, retaining the angle it makes with AB , then the point P , in the plane that we have taken as boundary plane between the spaces belonging to A and B , will describe a circle. The points lying halfway on the lines joining A with the points of that circle, and which therefore also trace a circle on the sphere A , namely the boundary of the segment under

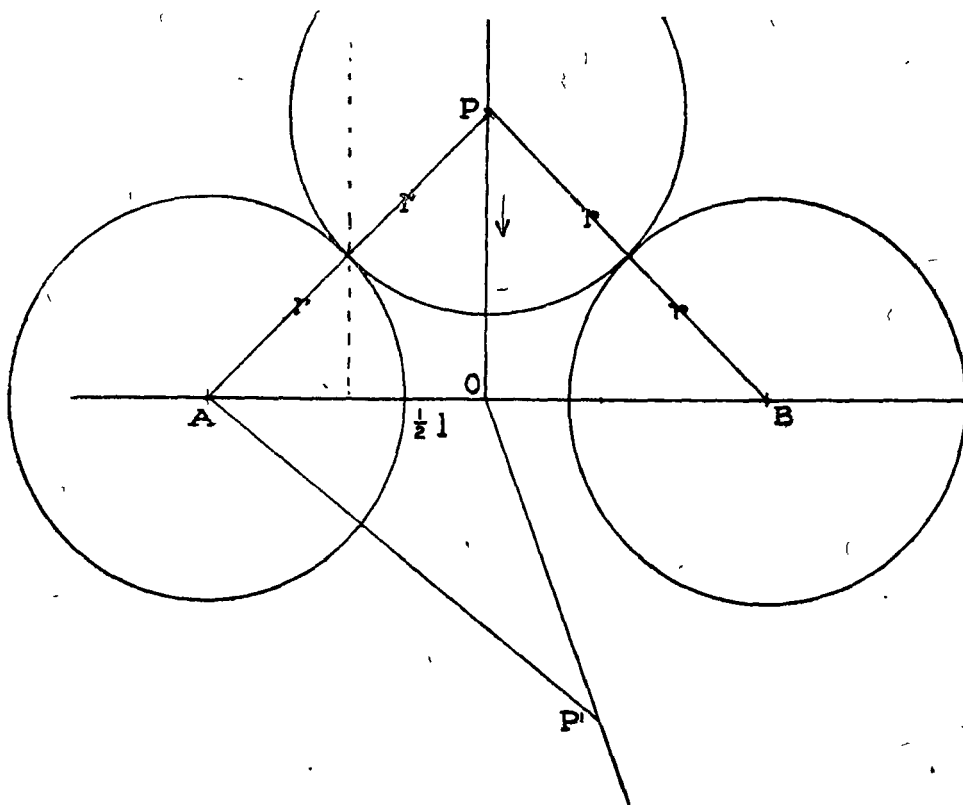

Fig 1.

discussion, show us what molecules coming from above yield the other points of the boundary of the segment. Of course this can only take place completely, so long as $h = OP$ is smaller than $r + \frac{l}{2}$.

For all the other points of the segment we can account either by moving A and B aside till the moving molecule can pass between them, or perhaps by its being brought about in a former volume, which was larger than the present one, or more probably by the fact that the limiting value of x is only a mean value of x .

Let us draw some adjoining squares normal to the movement of the molecule P , as belonging to the successive molecules A, B , etc. we have in the centre the molecule e.g. A , and at distances $r + \frac{2}{l}$ the four sides of the square. As soon as $\frac{l}{2} = r$ we have the critical

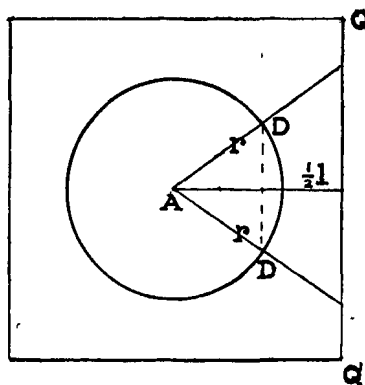

Fig. 2.

density. But if $\frac{l}{2} < r$ we have the case we are treating now. (See fig. 2). If now AQ is greater than $2r$, we have the case under discussion, that α is enlarged for righthand, and lefthand action, and likewise for action directed upwards and downwards, and round the point Q and round the three other vertices there is a certain space through which moving molecules can move without double contact. But as soon as $AQ = 2r$ we have the case that OP of fig. 1 is equal to $r + \frac{l}{2}$

or that $2\left(r + \frac{l}{2}\right)^2 = 4r^2$ or $\frac{r + \frac{l}{2}}{2r} = \frac{1}{\sqrt{2}}$, or $r(\sqrt{2} - 1) = \frac{l}{2}$, or $l = 2$

$(\sqrt{2} - 1)r$. To this value of $\frac{l}{2r} = \sqrt{2} - 1 = 0.414\dots$, the circum-

stances are probably owing which cause the rigidity. for so far as it is independent of the particular form of the molecules. If in fig. 2 we draw the two diagonals, in each of the four angular points a molecule might be placed, but the movement would be impossible,

even the thermal movement. On account of the forces directed to Q and to Q' the molecule A would then experience a resulting force equal to $a/2$, hence an increase of attraction equal to $a(1/2-1)$.

In the "Scientific Proceedings of the Royal Dublin Society" we have a series of data of SYDNEY YOUNG for the calculation of the value of a in the liquid state; he namely communicates the latent heat of evaporation at different temperatures up to very near the critical temperatures.

The recorded quantity of heat refers to the so called *external* latent heat, and the quantity a only refers to the *internal* latent heat. But

the latter can be calculated by multiplication by $\frac{\frac{T}{\rho} \frac{dp}{dT} - 1}{\frac{T}{p} \frac{dp}{dT}}$. If

this is known, we know $a_1 (d_1 - d_2)$. And d_1 and d_2 also having been given, the succeeding series of values of a can be calculated, and therefore $\frac{a_2}{a_1}$ for the different temperatures. I have found the following series of numerical values for ether. For:

T	$\frac{a_1}{a}$	$\frac{a_2}{a}$ calculated with $\frac{a_1}{a} - 1 = 1 \sqrt{\frac{v}{v_k}}$
193 . . .	1.025	
192 . . .	1.08	1.129
190 . . .	1.125	1.154
185 . . .	1.17	1.199
180 . . .	1.199	1.216
170 . . .	1.219	1.243
160 . . .	1.275	1.272
150 . . .	1.28	1.293
140 . . .	1.285	
130 . . .	1.294	1.314
120 . . .	1.304	
110 . . .	1.31	
100 . . .	1.325	1.344
70 . . .		1.366
50 . . .	1.338	1.377
30 . . .		1.398
0 . . .	1.415	1.403

If we take into account that the determination of the thermal quantities is so much more difficult than the determination of dimensions, the agreement between calculation and observation can be called satisfactory, and we may assign a high degree of probability

to the supposition, on which this calculation is founded that the molecular attraction only makes itself felt with perfect contact.

At first I had expected to find $\sqrt{\frac{v}{v_k}}$ instead of $\sqrt[3]{\frac{v}{v_k}}$. And strictly speaking the given values correspond to a power of $\frac{v}{v_k}$ slightly smaller than $\frac{1}{2}$, approaching more closely to $\frac{1}{2}$ as we keep closer to the critical temperature. But such a spherical figure for a molecule and the vacant space belonging to it presupposes no collisions. It gives to every molecule a spherical form and normal to the movement walls of a cubic shape at distances $= \frac{l}{2}$ from the centre. As we require the collisions to account for the increase of a , we may not assume this form, but we must make the molecules come in contact, and we must suppose spaces in which the molecules lie at the surface. They then are nearly disk-shaped. Perhaps this is the reason that will have to give the explanation of the square root form. And that our theory requires the square root cannot be doubted. Let us pay attention to the form of p. 361:

$$\frac{x}{r} = 1 - \frac{r + \frac{l}{2}}{2r} = 1 - \left(\frac{v}{v_k}\right)^n$$

or

$$\left(\frac{a_1}{a} - 1\right) = 1 - \left(\frac{v}{v_k}\right)^n$$

It has appeared from the first form that the points in which double contact takes place for given volume or temperature, lie in projection on a straight line that lies parallel to the line OP' , halfway between A and P . Compare fig. 1 or 2. In fig. 2 a projection lies parallel to QQ' and halfway between A and QQ' . The length of this projection is found by tracing lines from A to QQ' of a length equal to $2r$. If $AQ > 2r$, two such lines may be drawn to QQ' . The points D and D' are exceptional points, in which we can put at the same time x and

$1 - \frac{r + \frac{l}{2}}{2r}$ equal to 0; the point x because the thickness of the

segment is equal to 0 at that place, and $1 - \frac{r + \frac{l}{2}}{2r}$ because the quan-

tity $\frac{h}{2r}$ is equal to 0, hence $\frac{h}{2r} = \sqrt{1 - \left(\frac{r + \frac{l}{2}}{2r}\right)^2}$. Though $\frac{r + \frac{l}{2}}{2r}$ may be represented by $\left(\frac{v}{v_k}\right)^\mu$ as far as the value is concerned, it is better not to choose this form now that we have only to do with points in the *same* volume. If we did so, however, μ would have to be taken = 1.

But if we wish to judge about the thickness of the segment, hence about the value of $\frac{a_1}{a} - 1$ at different temperatures or in different volume, the form $\left(\frac{v}{v_k}\right)^\mu$ is necessary. From the form:

$$\frac{a_1}{a} - 1 = 1 - \left(\frac{v}{v_k}\right)^\mu$$

we see that only when $\frac{v}{v_k} = 1$, the ordinary value of a is found, which can therefore be denoted by a_L . At lower temperatures or at $v < v_l$ we will conclude to the value of μ . The original form is:

$$\frac{a_1}{v_k} - 1 = 1 - \frac{r + \frac{l}{2}}{2r}$$

If we compare the results in the two cases, it appears that the quantity which must be subtracted from the righthand side of 1

is in the first case $\left(\frac{r + \frac{l}{2}}{2r}\right)^2$ and in the second case $\frac{r + \frac{l}{2}}{2r}$ — and that consequently for the second case $\mu = \frac{1}{2}$. This result is in agreement with the observations in by far the most cases.

With $\sqrt{\frac{v}{v_k} = \frac{r + \frac{l}{2}}{2r}}$ we find for ether at 0:

$$\sqrt{\frac{1}{2,82} = \frac{1}{2} + \frac{l}{4r}}$$

$$\frac{4}{17} - 2 = \frac{l}{r}$$

$$0,37 = \frac{l}{r}$$

$$\text{or } 0,185 = \frac{l}{2r}$$

But not only for the latent heat it is of importance to keep apart the two cases, viz. space between the molecules greater or smaller than the dimensions of the molecule itself — it is also of importance for other phenomena. For example, friction, diffusion etc. It is not my purpose to demonstrate this myself in detail — the more so because it has already been pointed out by different observers that these phenomena follow different laws for liquids and gases. But I will particularly call attention to a paper by BATSCHINSKY, who already according to a communication in the *Journal de Physique* 1914 tried to explain the diffusion for liquids not by the thermal movement, but by the attraction of the molecules, hence by the quantity α of the equation of state, and who has given a view which is most probably at bottom essentially analogous to the above ¹⁾.

That in the title I have put the transition of the twin cases at the critical density, holds of course only for normal substances, so without association. But in general the transition case is that for which the distance of the molecules is equal to the dimension of the molecule. Before we have got perfect certainty about this, a thorough investigation also above the critical temperature would be necessary. This would probably be much more difficult, and I hope that also other investigators will show an interest in this research.

Astronomy. — “*Planetary motion and the motion of the moon according to EINSTEIN’S theory.*” By Dr. W. DE SITTER.

(Communicated in the meeting of June 24, 1916).

1. *The gravitational field of the sun.*

In EINSTEIN’S new theory gravitation is determined by 10 quantities g_{ab} , which are given by the differential equations ²⁾

$$G_{ab} - \frac{1}{2} g_{ab} G = -\kappa T_{ab}. \quad (1)$$

These equations are invariant for any arbitrary transformation of the “coordinates” $x_1 \dots x_4$, by means of which the phenomena are described. It is an essential feature of EINSTEIN’S theory that the

¹⁾ I have only read a short review in the *Journal de Physique*, but I think that I may conclude from it that BATSCHINSKY finds back the quantity b of the equation of state as characteristic quantity. This would be a corroboration of my opinion that the attraction of the molecules is only exerted in case of perfect contact.

²⁾ EINSTEIN: *Die Feldgleichungen der Gravitation*, Sitzungsber. Berlin, Nov. 1915 page 845, formula (2a). It is easily found that $G = \kappa T$.

equations (1) do not determine the g_{ab} completely. To determine them completely an arbitrary restriction must be added, which can be considered as a definition of the coordinates $x_1 \dots x_4$. In first approximation we find the ordinary mechanics according to NEWTON'S law, in the terms of higher order there remains an undeterminateness.

If we take rectangular coordinates $x_1 = x, x_2 = y, x_3 = z, x_4 = ct$ (c being the velocity of light in a portion of space where there is no matter and no gravitation), then the g_{ab} which determine the field of a sphere at rest at the origin of coordinates can be expressed in terms of three ¹⁾ quantities α, β, γ , which are of the first order of smallness. Thus

$$g_{11} = -(1 + \beta) + \frac{x_1^2}{r^2} (\beta - \alpha)$$

$$g_{ij} = \frac{x_i x_j}{r^2} (\beta - \alpha) \quad (i, j = 1, 2, 3) \quad (2)$$

$$g_{i4} = 0, \quad g_{44} = 1 + \gamma$$

If we introduce polar coordinates $x'_1 = r, x'_2 = \vartheta, x'_3 = \psi$ by the formulae of transformation:

$$x = r \cos \psi \cos \vartheta$$

$$y = r \cos \psi \sin \vartheta$$

$$z = r \sin \psi$$

then we find

$$g'_{11} = -(1 + \alpha)$$

$$g'_{22} = -(1 + \beta) r^2 \cos^2 \psi$$

$$g'_{33} = -(1 + \beta) r^2$$

$$g'_{ij} = 0 \text{ for } i \neq j. \quad (i, j = 1, 2, 3) \quad (2')$$

The radial symmetry requires that α, β, γ are functions of r alone.

The differential equations contain the quantities T_{ab} . If we neglect pressures etc. inside the sun, arising from the mutual gravitation of its parts, and if the material constituting the sun is at rest, these are

$$T_{ij} = 0 \quad T_{i4} = 0 \quad (i, j = 1, 2, 3)$$

$$T_{44} = \rho (1 + \gamma)$$

Here ρ is the number of material points contained in the four-dimensional element of volume $dx_1 dx_2 dx_3 dx_4$. We can take $dx_4 = c dt = 1$, and since the matter is at rest ρ then becomes the ordinary density.

I now write down the equations (1) of EINSTEIN. Differentials with respect to r are indicated by accents. Then I find

$$-\frac{1}{2}\gamma'' - \frac{\gamma'}{r} - \frac{1}{2}\gamma'(\beta' - \frac{1}{2}\alpha' - \frac{1}{2}\gamma') = -\frac{1}{2}\kappa(1 + \alpha)T'_{44} = -\frac{1}{2}\kappa\rho(1 + \alpha + \gamma) \quad (3)$$

¹⁾ See DROST, these Proceedings XVII (Dec. 1914) page 998.

$$\frac{\beta - \alpha}{r^2} - \frac{1}{2}\beta'' - \frac{1}{2}\gamma'' + \frac{1}{2r}(\alpha' + \gamma') = 0. \quad (4)$$

$$\frac{\beta - \alpha}{r^2} + \frac{1}{r}(\beta' + \gamma') = 0. \quad (5)$$

Exactly the same equations are found from the generalised principle of HAMILTON, as enounced by LORENTZ¹⁾. The equations as here given are only exact to the required order of accuracy. In a recent communication²⁾ MR. DROSTE has derived the complete equations from the same principle, and by an elegant analysis has succeeded in rigorously integrating them. In the present paper no rigorous solution will be attempted, but only an approximation to the order which is required for practical applications.

It is easily found that

$$\frac{1}{r} \frac{d}{dr} [\frac{1}{2} r^2 \cdot (5)] + (4) = \frac{1}{2} \cdot (5).$$

Consequently the equations (4) and (5) are not independent of each other. To determine α, β, γ completely we must, as has already been pointed out above, add an arbitrary condition.

EINSTEIN³⁾ advises $\sqrt{-g} = 1$, which, to the required order of accuracy, is equivalent to

$$\beta + \frac{1}{2}\alpha + \frac{1}{2}\gamma = 0$$

This equation, together with (3) and (5) determines α, β and γ . EINSTEIN finds

$$\gamma = -\frac{a}{r} \quad \beta = 0 \quad \alpha = -\gamma.$$

DROSTE in the paper already quoted introduces a condition, which is equivalent to $\beta = 0$. He finds

$$\gamma = -\frac{a}{r} \quad \beta = 0 \quad 1 + \alpha = \frac{1}{1 + \gamma}.$$

This result is entirely rigorous, while EINSTEIN's was only approximate. Within the limits of the approximation given by EINSTEIN the two are identical. Both EINSTEIN and DROSTE consider only the field *outside* the sun.

I will take as arbitrary condition

¹⁾ These Proceedings, Feb. 1916 (Not yet translated into English).

²⁾ These Proceedings, Vol. XIX, page 197 (May 1916).

³⁾ *Erklärung der Perihelbewegung des Merkur aus der allgemeinen Relativitätstheorie*, Sitzungsber. Berlin, Nov. 1915, page 833. It would be better to say that EINSTEIN's condition is that $\sqrt{-g}$ shall be independent of gravitation. For rectangular coordinates EINSTEIN has indeed $g = -1$, for polar coordinates this becomes $g = -r^2 \cos^2 \psi$.

$$\beta - \alpha = 0.$$

Then (5) gives

$$\beta + \gamma = \text{const.}$$

Since at infinity both β and γ must be zero, the constant is also zero. We have thus

$$\alpha = \beta = -\gamma \dots \dots \dots (6)$$

The equation (3) now becomes, accurate to the second order

$$r^2 (\gamma'' - \gamma'^2) + 2r\gamma' = \kappa r^2 \rho.$$

We can split up γ in its terms of the first and of the second order, thus

$$\gamma = \gamma_1 + \gamma_2,$$

then we have the two equations

$$r^2 \gamma_1'' + 2r\gamma_1' = \kappa r^2 \rho \dots \dots \dots (7)$$

$$r^2 \gamma_2'' + 2r\gamma_2' = r^2 \gamma_1'^2 \dots \dots \dots (8)$$

The integration is not difficult. First I will introduce instead of κ the GAUSSIAN constant k . We have

$$\kappa = 8\pi\lambda_0^2, \quad \lambda_0 = \frac{k}{c}.$$

If now we put

$$4\pi \int_0^r r^2 \rho dr = m(r), \dots \dots \dots (9)$$

then we find from (7)

$$r^2 \gamma_1' = 2\lambda_0^2 m(r)$$

and then from (8)

$$r^2 \gamma_2' = -\frac{4\lambda_0^4}{r} m(r)^2 + 8\lambda_0^4 q(r),$$

where we have put

$$4\pi \int_0^r r \rho m(r) dr = q(r) \dots \dots \dots (10)$$

If now we put

$$m'(r) = m(r) + 4\lambda_0^2 q(r) \dots \dots \dots (11)$$

then

$$\gamma' = \frac{\lambda_0^2}{r^2} m'(r) - \frac{4\lambda_0^4}{r^3} m(r)^2 \dots \dots \dots (12)$$

from which we find easily

$$\gamma = -\frac{2\lambda_0^2}{r^2} m'(r) + \frac{2\lambda_0^4}{r^2} m(r)^2 + 8\pi\lambda_0^2 \int_{\infty}^r [r + 3\lambda_0^2 m(r)] \rho dr$$

The lower limit of the last integral has been so chosen that at infinity we have $\gamma = 0$.

Put now

$$4\pi \int_0^r [r + 3\lambda_0^2 m(r)] \rho dr = n(r) \quad , \quad n(R) = N,$$

R being the sun's radius. Then, since for $r > R$ (i.e. outside the sun) $\rho = 0$, we find

$$\gamma = -\frac{2\lambda_0^2}{r} m'(r) + \frac{2\lambda_0^4}{r^2} m(r)^2 + 2\lambda_0^2 [n(r) - N]. \quad . \quad . \quad (13)$$

These formulae can be used both inside and outside the sun, if we neglect the strains and pressures caused by gravitation inside the sun. Outside we have $n(r) = N$, and $m'(r)$ and $m(r)$ are constants. Since the difference $m' - m$ is of the order of λ_0^2 , we can in the term which has λ_0^4 as a factor use m' instead of m . If now we put

$$\lambda^2 = \lambda_0^2 m'(R) = \frac{k^2 m'}{c^2}$$

then the formulae *outside the sun* become

$$\left. \begin{aligned} \gamma' &= \frac{2\lambda^2}{r^2} - \frac{4\lambda^4}{r^3} \\ \gamma &= -\frac{2\lambda^2}{r} + \frac{2\lambda^4}{r^2} \end{aligned} \right\} \quad . \quad . \quad . \quad (14)$$

The quantity $2\lambda^2$, which corresponds to EINSTEIN's \mathbf{a} , has the dimension of a length. For the sun its value is 2.945 km, for an atom of hydrogen 5×10^{-48} microns. For $r = 2\lambda^2$ we have $\gamma' = 0$. The remarkable consequences of this fact have been very completely investigated by DROSTE. In actual problems r is always very much larger¹⁾ than $2\lambda^2$.

The values of g_{ab} are now, for rectangular coordinates

$$g_{11} = g_{22} = g_{33} = -1 + \gamma \quad , \quad g_{44} = 1 + \gamma \quad . \quad . \quad (15)$$

and for polar coordinates

$$g'_{11} = -1 + \gamma \quad g'_{22} = -r^2 \cos^2 \psi (1 - \gamma) \quad g'_{33} = -r^2 (1 - \gamma) \quad g'_{44} = 1 + \gamma \quad (16)$$

Those not mentioned are zero.

These g_{ab} are simpler than those of EINSTEIN and DROSTE, since here all $g_{ij} = 0$ for $i \neq j$. Thus e.g. the velocity of light in γ 's system of reference is

$$\frac{d\sigma}{cdt} = 1 + \gamma,$$

¹⁾ DROSTE's formulae, like (14), only represent the field *outside* the sun.

while in EINSTEIN'S system it is

$$\frac{d\sigma}{cdt} = 1 + \frac{1}{2}\gamma(1 + \cos^2 V)$$

Here $d\sigma$ is a line-element in the three-dimensional space (x_1, x_2, x_3) and V is the angle between this element and the radius-vector. The curvature of rays of light of course is the same in both systems.

2. The equations of motion.

The world-line of a material point is a geodetic line of which the differential equations are

$$\frac{d^2 x_i}{ds^2} + \sum_p \sum_q \left\{ \begin{matrix} pq \\ i \end{matrix} \right\} \frac{dx_p}{ds} \frac{dx_q}{ds} = 0 \quad (i, p, q = 1 \dots 4)$$

Here ds is the element of the world-line, which is given by

$$ds^2 = \sum_p \sum_q g_{pq} dx_p dx_q$$

All sums are to be taken from 1 to 4.

If now we take $x_4 = ct$ we find easily

$$\frac{d^2 x_i}{c^2 dt^2} = - \sum_p \sum_q \left[\left\{ \begin{matrix} pq \\ i \end{matrix} \right\} - \left\{ \begin{matrix} pq \\ 4 \end{matrix} \right\} \dot{x}_i \right] \dot{x}_p \dot{x}_q \quad \left(\begin{matrix} i = 1, 2, 3 \\ p, q = 1 \dots 4 \end{matrix} \right) \quad (17)$$

The points indicate differentials with respect to ct , so that $\dot{x}_4 = 1$.

The brackets $\left\{ \begin{matrix} pq \\ i \end{matrix} \right\}$ are easily found from the g_{ab} . To the required order of accuracy we have, for rectangular coordinates:

$$\left. \begin{aligned} \left\{ \begin{matrix} pp \\ i \end{matrix} \right\} &= \frac{\lambda^2 x_i}{r^3}, & \left\{ \begin{matrix} pi \\ i \end{matrix} \right\} &= -\frac{\lambda^2 x_p}{r^3}, & \left\{ \begin{matrix} ii \\ i \end{matrix} \right\} &= -\frac{\lambda^2 x_i}{r^3} \\ \left\{ \begin{matrix} 44 \\ i \end{matrix} \right\} &= \frac{\lambda^2 x_i}{r^3} - 4 \frac{\lambda^4 x_i}{r^4}, & \left\{ \begin{matrix} p4 \\ 4 \end{matrix} \right\} &= \frac{\lambda^2 x_p}{r^3} \end{aligned} \right\} \quad (18)$$

and for polar coordinates

$$\left. \begin{aligned} \left\{ \begin{matrix} 11 \\ 1 \end{matrix} \right\}' &= -\frac{\lambda^2}{r^2}, & \left\{ \begin{matrix} 22 \\ 1 \end{matrix} \right\}' &= -r \cos^2 \psi \left(1 - \frac{\lambda^2}{r} \right), & \left\{ \begin{matrix} 33 \\ 1 \end{matrix} \right\}' &= -r \left(1 - \frac{\lambda^2}{r} \right) \\ \left\{ \begin{matrix} 12 \\ 2 \end{matrix} \right\}' &= \left\{ \begin{matrix} 13 \\ 3 \end{matrix} \right\}' = \frac{1}{r} \left(1 - \frac{\lambda^2}{r} \right), & \left\{ \begin{matrix} 22 \\ 3 \end{matrix} \right\}' &= \sin \psi \cos \psi, \\ \left\{ \begin{matrix} 32 \\ 2 \end{matrix} \right\}' &= -\tan \psi, & \left\{ \begin{matrix} 44 \\ 1 \end{matrix} \right\}' &= \frac{\lambda^2}{r^2} - 4 \frac{\lambda^4}{r^3}, & \left\{ \begin{matrix} 14 \\ 4 \end{matrix} \right\}' &= \frac{\lambda^2}{r^2} \end{aligned} \right\} \quad (19)$$

Those not mentioned are zero. If now we put $\lambda^2 = \frac{k^2}{c^2} m$, (where m is the same as m' of the preceding article), then the equations of motion become, for rectangular coordinates:

$$\frac{d^2 x_i}{dt^2} + k^2 m \frac{x_i}{r^3} = k^2 m \left\{ \frac{4\lambda^2 x_i}{r^4} + 4 \frac{\dot{x}_i \dot{r}}{r^2} - \frac{x_i}{r^3} \dot{\varphi}^2 \right\}, \dots \quad (20)$$

and for polar coordinates

$$\left. \begin{aligned} \frac{d^2 r}{dt^2} - r \cos^2 \psi \left(\frac{d\vartheta}{dt} \right)^2 - r \left(\frac{d\psi}{dt} \right)^2 + \frac{k^2 m}{r^2} &= k^2 m \left\{ \frac{4\lambda^2}{r^3} + 4 \frac{\dot{r}^2}{r^2} - \frac{\dot{\varphi}^2}{r^2} \right\}, \\ \frac{d^2 \vartheta}{dt^2} + \frac{2}{r} \frac{dr}{dt} \frac{d\vartheta}{dt} - 2 \tan \psi \frac{d\vartheta}{dt} \frac{d\psi}{dt} &= 4 k^2 m \frac{\dot{r} \dot{\vartheta}}{r^2}, \\ \frac{d^2 \psi}{dt^2} + \frac{2}{r} \frac{dr}{dt} \frac{d\psi}{dt} + \sin \psi \cos \psi \left(\frac{d\vartheta}{dt} \right)^2 &= 4 k^2 m \frac{\dot{r} \dot{\psi}}{r^2}, \end{aligned} \right\} \quad (21)$$

where we have put

$$\dot{\varphi}^2 = \dot{x}^2 + \dot{y}^2 + \dot{z}^2 = r^2 + r^2 \cos^2 \psi \dot{\vartheta}^2 + r^2 \dot{\psi}^2.$$

The right-hand members are of the second order. The left-hand members put equal to zero give the motion according to NEWTON'S law.

3. Planetary motion.

From the third equation (21) it follows, that when once $\varphi = 0$ and $\dot{\varphi} = 0$, this always remains true: the orbit is plane. Then we have, accurate to the second order

$$\ddot{\vartheta} + \frac{2}{r} \dot{r} \dot{\vartheta} = \dot{r} \dot{\vartheta} (\gamma' - \beta') \dots \dots \dots (22)$$

This equation is general; if we introduce the special values of β and γ which are here used, it is reduced to the second of (21). We now put

$$r^2 \dot{\vartheta} = G.$$

Then the integral of (22) is

$$G = G_0 e^{l-\beta} \dots \dots \dots (23)$$

This equation replaces the integral of areas.¹⁾ I now put

$$G_0 = \lambda \sqrt{p_0}$$

Then, with our values of β and γ we find

¹⁾ If we put $r^2 \frac{d\vartheta}{ds} = \bar{G}$, ds being the element of the world-line, i.e. the *proper-time* of the planet, then we find

$$\bar{G} = G_0 e^{-\beta}.$$

If we take $\beta = 0$, as in EINSTEIN'S system, then the law of areas is exact if the proper-time of the planet is taken as independent variable, as has already been remarked by EINSTEIN (l. c. page 887).

$$r^2 \dot{\vartheta} = \lambda \sqrt{p_0} \left(1 - \frac{4\lambda^2}{r}\right), \dots \dots \dots (24)$$

or

$$r^3 \frac{d\vartheta}{dt} = k \sqrt{m} \sqrt{p_0} \left(1 - \frac{4\lambda^2}{r}\right).$$

The first of (21) is

$$r - r\dot{\vartheta}^2 + \frac{\lambda^2}{r^2} = \frac{4\lambda^4}{r^3} + 4\lambda^2 \frac{\dot{r}^2}{r^2} - \lambda^2 \frac{\varphi^2}{r^2} \dots \dots \dots (25)$$

If we multiply (25) by \dot{r} and (22) by $r^2 \dot{\vartheta}$, and add, we find

$$\frac{d}{cdt} \left(\frac{1}{2} \varphi^2 - \frac{\lambda^2}{r} \right) = \left(3\varphi^2 + \frac{4\lambda^2}{r} \right) \frac{\lambda^2 \dot{r}}{r^2} \dots \dots \dots (26)$$

The lefthand member put equal to zero gives, as in NEWTON'S theory

$$\frac{1}{2} \varphi^2 - \frac{\lambda^2}{r} = const.$$

The constant I call $-\frac{\lambda_0^2}{2a_0}$. Thus we have the approximation

$$\varphi^2 = \frac{2\lambda^2}{r} - \frac{\lambda^2}{a_0}, \dots \dots \dots (27)$$

or

$$\left(\frac{dr}{dt}\right)^2 + r^2 \left(\frac{d\vartheta}{dt}\right)^2 = k^2 m \left(\frac{2}{r} - \frac{1}{a_0}\right),$$

If this is introduced into the right-hand member of (26), this becomes

$$\frac{d}{cdt} \left(\varphi^2 - \frac{2\lambda^2}{r} \right) = \left(\frac{20\lambda^4}{r^3} - \frac{6\lambda^4}{a_0 r^2} \right) r,$$

from which

$$\varphi^2 - \frac{2\lambda^2}{r} + \frac{\lambda^2}{a_0} = \frac{6\lambda^4}{a_0 r} - \frac{10\lambda^4}{r_0^2} \dots \dots \dots (28)$$

The right-hand member is of the second order. If it is neglected (28) becomes the same as (27), i. e. the integral of living forces in NEWTON'S theory

To find the orbit we must eliminate cdt from (24) and (28). This gives

$$\left(\frac{dr}{d\vartheta}\right)^2 + r^2 - \frac{2r^3}{p_0} + \frac{r^4}{a_0 p_0} = \frac{6\lambda^2 r^2}{p_0} - \frac{2\lambda^2 r^3}{a_0 p_0}.$$

If now we put

$$p_1 = p_0 \left(1 + \frac{\lambda^2}{a_0}\right)$$

and if we introduce

$$y = \frac{1}{r}$$

then we find

$$\left(\frac{dy}{d\vartheta}\right)^2 + y^2 - \frac{2}{ip}y + \frac{1}{a_0 p_0} = \frac{6\lambda^2}{p_0} y^2 \quad \dots (29)$$

EINSTEIN¹⁾ has the same equation. only his righthand member is ay^3 . The difference is caused by the difference in the arbitrary condition introduced to complete the determination of the g_{ab} . The integration of (29) is easier than of the corresponding equation of EINSTEIN, which leads to elliptic functions. We find easily

$$y = \frac{1}{g^2 p_1} + \frac{e_1}{p_1} \cos(g\vartheta - \omega),$$

where e_1 and ω are constants of integration, and

$$g = 1 - \frac{3\lambda^2}{p_1} \quad \dots (30)$$

If now we put

$$p = g^2 p_1, \quad e = g^2 e_1, \quad a = g^2 \frac{p_0}{p} a_0 = a_p - \lambda^2,$$

then we have

$$p = a(1 - e^2) \quad \dots (31)$$

and

$$\frac{1}{r} = \frac{1 + e \cos(g\vartheta - \omega)}{p} \quad \dots (32)$$

The orbit is thus an ellipse of which the perihelion moves in the direction of the orbital motion. The displacement of the perihelion during one revolution is $\frac{2\pi}{g} - 2\pi = \frac{3\lambda^2}{p} 2\pi$. This same value has been found by EINSTEIN. The numerical value is for the different planets, in one century:

<i>Mercurius</i>	$\delta\tilde{\omega} = + 42'' 9$	$e\delta\tilde{\omega} = + 8'' 82$
<i>Venus</i>	8.6	+ 0.05
<i>Earth</i>	3.8	+ 0.07
<i>Mars</i>	1.3	+ 0.13

If the elements a and p are introduced in (24), this becomes

$$r^2 \frac{d\vartheta}{dt} = k \sqrt{m} \sqrt{p \left(1 - \frac{1}{2} \frac{\lambda^2}{a} + \frac{3\lambda^2}{p} - \frac{4\lambda^2}{r}\right)} \quad \dots (33)$$

¹⁾ l. c. page 837, formula (11) DROSE of course finds the same formula as EINSTEIN, and he integrates it by means of elliptic functions.

If from this we solve $\frac{dt}{d\vartheta}$, multiply by $d\vartheta$, and integrate from 0 to 2π , we find the period of revolution T . The result naturally depends on the point of starting, i.e. on the point on the ellipse where $\vartheta = 0$. In the moving ellipse the true anomaly is

$$v = g\vartheta - \omega.$$

If we take this as independent variable, we must integrate from v_1 to $v_2 = v_1 + 2\pi g$. I find in this way

$$T = \frac{2\pi a^{3/2}}{k\sqrt{m}} \left[1 + \frac{9}{2} \frac{\lambda^2}{a} - \frac{3\lambda^2}{p} + \frac{6\lambda^2}{p} e \cos l_0 + \dots \right],$$

where l_0 is the mean anomaly corresponding to the true anomaly $v_0 = \frac{1}{2}(v_1 + v_2)$. All neglected terms of the series, as well as the last term which has been included, are periodic. If these are omitted, we find the mean period T_0 . If then we put $nT_0 = 2\pi$, we find

$$a^3 n^3 = k^2 m \left[1 - \frac{3\lambda^2}{p} (1 - 3e^2) \right] \dots \dots \dots (34)$$

which replaces KEPLER'S third law.

Let the excentric and the mean anomaly in the moving ellipse, corresponding to the true anomaly v , be called u and l respectively. Then

$$u - e \sin u = l$$

$$\frac{dl}{dt} = n \left[1 + \frac{\lambda^2}{p} (1 - 4e^2) - \frac{4\lambda^2}{r} \right] \dots \dots \dots (35)$$

The mean value of the expression within the square bracket over a complete revolution in the (moving) ellipse is $1 - \frac{3\lambda^2}{p} = g$.

4. *The motion of the moon.*

The moon will be considered as a material point, of which we will investigate the motion in the gravitational field of the sun and the earth.

We take an arbitrary system of rectangular coordinates, in which

- x_i , Δ are the heliocentric coordinates of the moon,
- ξ_i , ϱ " " " " " " " " earth,
- x_i , r " " geocentric " " " " moon.

Thus $x_i = x_i - \xi_i$, and we put

$$\lambda^2 = \lambda_0^2 m \quad , \quad \lambda_1^2 = \lambda_0^2 m_1,$$

m being the mass of the sun, and m_1 of the earth. We can neglect

the excentricity of the earth, q is then a constant. The equations of motion are (17), in which the brackets $\left\{ \begin{smallmatrix} pq \\ i \end{smallmatrix} \right\}$ and $\left\{ \begin{smallmatrix} pq \\ 4 \end{smallmatrix} \right\}$ must be derived by means of the usual formulae from the g_{ij} , which are determined by (1). The right-hand members of (1), i. e. the quantities T_{ij} , are zero except in those parts of the four-dimensional time-space, where the sun and the earth are. Since these two bodies never co-incide, we have always only one T_{ij} , either $(T_{ij})_0$ or $(T_{ij})_1$. We can suppose the sun to be at rest. Then $(T_{ij})_0$ has the same value as above. For the earth, which moves, we can put

$$(T_{ij})_1 = (T_{ij})_1^0 + \delta(T_{ij})_1,$$

the first term on the right being the value which we should find if the earth were at rest.

I will restrict the determination of the g_{ij} to an approximation, which is sufficient to give all *secular* terms of the order of magnitude of observable quantities.

We can conceive the g_{ij} to be made up of several parts, thus

$$g_{ij} = (g_{ij})_0 + (g_{ij})_1 + \bar{g}_{ij}.$$

The first two terms taken separately need not correspond to a real problem, they are only mathematically defined as follows: $(g_{ij})_0$ is what we find if in (1) we take account of $(T_{ij})_0$ only, and similarly $(g_{ij})_1$ arises from $(T_{ij})_1$. If now the equations (1) were linear in the g_{ij} and their differential coefficients, then $(g_{ij})_0 + (g_{ij})_1$ would be the complete solution. It follows that \bar{g}_{ij} is of the second order, and need therefore only be computed for $i = j = 4$.

Let us first consider the others, of which $(g_{ij})_0$ is the same as before. We can take $(g_{ij})_1 = (g_{ij})_1^0 + \delta(g_{ij})_1$, where the two parts arise from the two parts of $(T_{ij})_1$. The term $\delta(T_{ij})_1$ is at least of the order $\frac{1}{2}$, i. e. of the order of the velocities, and need only be taken into account in the determination of g_{i4} . It there produces a term of the order $\lambda^2 \xi$ which contains odd functions of the angle Moon—Earth—Sun, and therefore only gives rise to periodic terms of the order ξ^2 , which we neglect. It will appear that even the secular terms of this order are entirely negligible.

By a similar reasoning we find that the term $\delta(g_{44})_1$ will be of the order $\lambda^2 \xi^2$, and the secular terms which may perhaps result from this term will be far beyond the limit of observability.

There remains the term \bar{g}_{44} . This will be of the order $\lambda^2 \lambda_1^2$, and will also contain the angle already mentioned. It can consequently also be neglected.

We thus come to the conclusion that we shall reach a sufficient approximation by simply superposing the fields of the earth and of the sun, both computed as if these bodies were at rest, i.e. by taking throughout ¹⁾

$$g_{ij} = (g_{ij})_0 + (g_{ij})_1^0.$$

Then we have rigorously

$$\frac{d^2 x_i}{dt^2} = \left(\frac{d^2 x_i}{dt^2} \right)_1^0 + \left(\frac{d^2 x_i}{dt^2} \right)_0 - \left(\frac{d^2 \xi_i}{dt^2} \right)_0,$$

where the meaning of the different suffixes will be easily understood. The first term gives the same result that has already been found above for the planetary motion, viz. a secular motion of the perigee amounting to $\frac{3\lambda_1^2}{p} \cdot nt$. In one century this is 0'.06, which is entirely negligible. The other terms are found by writing the equation (20) for the moon and for the earth and subtracting the latter from the former. The left-hand members then give the perturbing function as used in the current lunar theory. This contains the factor $\frac{k^2 m}{\rho^3}$, which is by KEPLER'S third law replaced by n'^2 , n' being the mean motion of the sun. Now however this law must be replaced by (34) and we have consequently

$$\frac{k^2 m}{\rho^3} = n'^2 \left[1 + \frac{3\lambda^2}{\rho} \right].$$

We must therefore apply a correction to the ordinary perturbing function.

The right-hand members of (20) give

$$\delta \frac{d^2 x_i}{dt^2} = k^2 m \left\{ \frac{4\lambda^2 x_i}{\Delta^3} - \frac{4\lambda^2 \xi_i}{\rho^3} + \frac{4x_i \Delta}{\Delta^3} - \frac{4\xi_i \rho}{\rho^3} - \frac{x_i}{\Delta^3} \rho_1^2 + \frac{\xi_i}{\rho^3} \rho_2^2 \right\}, \quad (36)$$

where we have put

$$\rho_1^2 = \sum x_i^2, \quad \rho_2^2 = \sum \xi_i^2 \quad (\sum \text{ from 1 to 3}).$$

Further we have $x_i = \xi_i + x_i$ etc., and

$$\Delta^2 = \rho^2 \left[1 + 2 \frac{\sum \xi_i x_i}{\rho^2} + \frac{r^2}{\rho^2} \right]$$

We develop in powers of r/ρ and we neglect the square and higher powers of this small quantity. We also take, as has already been remarked, $\rho = 0$, and we neglect all periodic terms. I then find the following radial, transversal and orthogonal perturbing forces

¹⁾ Simultaneously with the present communication Mr. DROSTE has published (these Proceedings, June 1916) the complete values of g_{ij} for n moving bodies. His results applied to the lunar theory entirely confirm the conclusion which was reached above.

$$\begin{aligned}
 S &= -3\mu \frac{v}{\rho} r \vartheta - \frac{3}{2} \mu \frac{v^2}{\rho} r, \\
 T &= +3\mu \frac{v}{\rho} r_1 \dots \dots \dots (37) \\
 W &= +3\mu \frac{v}{\rho} z \vartheta + \frac{9}{2} \frac{v^2}{\rho} z.
 \end{aligned}$$

In these formulae r and ϑ are the coordinates of the moon in its orbit, and z is the coordinate perpendicular to the ecliptic. Further μ is the ratio m/m_1 of the masses of the sun and the earth and v is the mean motion of the sun divided by the velocity of light, $v = n'/c$. It appears that the second terms in S and W are exactly cancelled by the correction to the ordinary perturbing force, which was mentioned above, and need thus not be computed. The other terms give a secular motion of the perigee and the node, both of the same amount, viz.:

$$\delta\tilde{\omega} = \delta\Omega = \frac{3}{2} \mu \frac{a^{3/2} \lambda_1 v}{\rho} n t \dots \dots \dots (38)$$

The motion in one century is
 $+ 1''.91$.

Beyond these motions of the perigee and the node there are no new secular terms in the motion of the moon.

5. *Comparison with the observations.*

The observed values have been taken from NEWCOMB¹⁾. I have, however, reduced them to the value 5024''.90 of the precessional constant (for 1850.0). To the theoretical values as given by NEWCOMB I have added the motions of the perihelia which have been found above. We then find, for one century

$e d \tilde{\omega}$	<i>Observed</i>	<i>Theory</i>	<i>Difference</i>
<i>Mercury</i>	+ 118''00 ± 0''40	+ 118''58 ± 0''16	- 0''58 ± 0''43
<i>Venus</i>	+ 0.28 ± .20	+ 0.39 ± .15	- 0.11 ± .25
<i>Earth</i>	+ 19.46 ± .12	+ 19.45 ± .05	+ 0.01 ± .13
<i>Mars</i>	+ 149.44 ± .35	+ 148.93 ± .04	+ 0.49 ± .35
$\sin i d \Omega$			
<i>Mercury</i>	- 92.03 ± 0.45	- 92.50 ± 0.16	+ 0.47 ± 0.48
<i>Venus</i>	- 105.47 ± .12	- 106.00 ± .12	+ 0.53 ± .17
<i>Mars</i>	- 72.64 ± .20	- 72.63 ± .09	- 0.01 ± .22

¹⁾ *Astronomical constants*, page 109.

The mean errors have been taken from NEWCOMB. For the moon we have ¹⁾:

	Observed	Theory	Difference
$d\tilde{\omega}$	BROWN, COWELL $+14643536'' \pm 2''$ NEWCOMB, DE VOS 14643530 ± 2	$+14643534'' \pm 2''$	$+2'' \pm 3''$ -4 ± 3
$d\delta_b$	NEWCOMB, BROWN -6967944 ± 2	-6967939 ± 2	-5 ± 3

With respect to the perihelion of Mercury we may remark that the residual, which without the new term, resulting from EINSTEIN'S theory (but with the improved constant of precession) would be $+8''.24$, has now become negative. The matter within the orbit of Mercury, by the attraction of which SEELIGER explained the anomalous motion of the perihelion, must thus have an exceedingly small density, certainly less than say $1/200$ ²⁾ of the value adopted by SEELIGER.

The residuals now show no preference for either the positive or the negative sign, there is thus no reason to suppose a rotation of the empirical system of coordinates with respect to the inertial system, as was done by ANDING and SEELIGER. In other words the precessional constant as found from motions within the solar system is the same as that determined from the fixed stars.

The residual of the node of Venus remains large. We might perhaps still be inclined to ascribe this deviation to the attraction of the masses reflecting the zodiacal light (SEELIGER'S second ellipsoid). Since the rotation cannot help us, the density of this ellipsoid would then have to be 3 or 4 times the value assumed by SEELIGER. From the computations by Mr. WOLTJER ³⁾ it has appeared that this density can certainly not exceed SEELIGER'S value, because a larger density would give values for the secular variation of the inclination of the ecliptic and for the planetary precession, which are absolutely contradictory to the results of observations. SEELIGER'S second ellipsoid can thus not explain the observed discrepancies ⁴⁾. Corrections

¹⁾ *The motion of the lunar perigee and node*, these Proceedings XVII (April 1915) page 1309.

²⁾ J. WOLTJER. *On SEELIGER'S hypothesis*, these Proceedings XVII (April 1914) page 23; W DE SITTER, *Remarks on Mr. WOLTJER'S paper*, *ibid.* page 33.

³⁾ If SEELIGER'S second ellipsoid is adopted with the density ascribed to it by SEELIGER, we would find the following residuals.

	$ed\tilde{\omega}$	$\sin id\delta_b$	d_i
Mercury	$-0''.47 \pm 0''.43$	$+0''.49 \pm 0''.48$	$+0''.44 \pm 0''.80$
Venus	$-0.10 \pm .25$	$+0.39 \pm .17$	$+0.37 \pm .33$
Earth	$+0.05 \pm .13$		$+0.23 \pm .27$
Mars	$+0.46 \pm .35$	$-0.04 \pm .22$	$+0.01 \pm .20$

The value of d_i for the earth is the secular variation of the inclination of the

to the adopted masses also cannot help us. If the mass of Mercury were multiplied by 3, which of course in itself is outside all limits of probability, the node of Venus would be put right, but we should then have a still larger discrepancy e.g. in the perihelion of Venus. It is not possible to find a system of masses which will reduce all residuals to within their mean errors.

Chemistry. — “*Investigations on the Temperature-Coefficient of the Free Molecular Surface-Energy, of Liquids between -80° and 1650° C.*” **XV.** “*The Determination of the Specific Gravity of molten Salts, and of the Temperature-Coefficient of their Molecular-Surface-Energy*”. By Prof. Dr. F. M. JAEGER and Dr. JUL. KAHN.

(Communicated in the meeting of June 24, 1916).

§ 1. For the calculation of the molecular free surface-energy of the molten salts and other compounds, about which we have previously communicated ¹⁾, it is necessary to know the specific gravity of the investigated liquids at temperatures ranging from -80° up to 1650° C.

As far as organic liquids are concerned, the usual and generally known methods can be applied, — at least if the temperatures of measurement are not too far apart from the range usually considered in laboratory-experiments. In those cases we used in the first place the *pycnometer*: Commonly this consisted in a double-walled vessel, the space between the glass-walls being carefully evacuated; it was closed by means of a ground thermometer. In most cases the densities were determined in thermostats at 25° , 50° and 75° C. In the work with liquids of low boilingpoint such measurements had to be made also at the temperature of melting ice, or in refrigerant mixtures of salt and ice, or in those of solid carbondioxide and alcohol; in these cases the pycnometer is evidently not a suitable instrument, and the pycnometrical method appears for many reasons much less adapted than the *volumetrical* method.

More particularly in the determination of the specific gravities of the low-boiling aliphatic *amines*, which moreover will absorb readily the carbondioxide and the water-vapour from the atmosphere, the *volumeter* appeared to be the only applicable instrument, while ecliptic. For the planetary precession we should have a correction amounting to $+0.30$ per centum. These residuals are not appreciably better than those given above in the text. (Note added in the English translation).

¹⁾ F. M. JAEGER and Collaborators, these Proceedings, 1914, '15 and '16.

furthermore special precautions had to be taken in filling the apparatus. Therefore the filling of the instrument was executed in the following way: The volatile liquid is contained in a sealed vessel *A* (fig. 1), which is placed in a DEWAR-glass, in a mixture of solid carbon dioxide and alcohol. On continuous cooling the vessel is rapidly sealed to the further glass-apparatus, after the capillary glass-tube is broken off. While the fat-free stopcocks r_1 and r_2 are closed, a current of dry air, freed from water and carbon dioxide by means of quick lime and sodium hydroxide, is introduced by T_1 . Then the tube T_1 is sealed off, and now the volumeter is sealed to the appa-

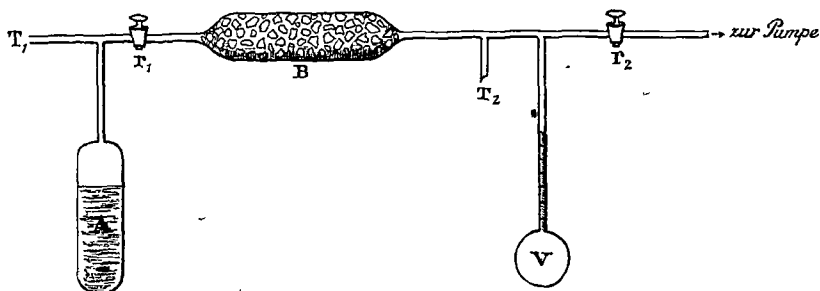

Fig. 1.

atus, during which operation the air can escape through T_2 . This being finished, also T_2 is sealed off; then the stopcocks r_1 and r_2 are opened, and the whole apparatus is evacuated. Now the volumeter is placed into the cold bath, and the stopcock r_1 is opened again; after the desired quantity of liquid is distilled from *A* into *V*, during which the vapour in passing again the tube *B* filled with dry and pure BaO , gives off its last traces of humidity, the stem of *V* is sealed-off at a point lying considerably higher than the highest division of the capillary tube.

Then the whole apparatus is accurately weighed. Now the volumetrical measurements are made at the desired temperatures; and finally the volumeter is carefully opened by removing the end of the capillary tube, and after cleaning and completely drying, the empty apparatus is weighed again, together with the removed piece of glass. The difference of the two weights gives the weight of the liquid used, whose volumina now are determined at different temperatures, because the volumeter has been accurately calibrated previously. After the necessary corrections the specific gravity at the said temperatures can be easily calculated from these data. The capillary tube has to be completely cylindrical, they were thick-walled, and accurately calibrated by means of liquids, whose specific gravities at a whole series of temperatures were exactly known.

Experience shows, that in most cases the third figure could still be considered to be certain, — which accuracy is wholly sufficient for our purpose.

2. Of course neither a pycnometer nor a volumeter could be used in cases, where the organic substances had a too high melting-point; and à fortiori this was the case with the inorganic salts melting at extremely high temperatures. In these cases the only way was to use a *hydrostatical* method, in which a sinker is used, which is described in detail further-on. Only in such cases, where the substance investigated appeared to be so volatile, as to give a rapid sublimation against the colder parts of the suspension-wire, it was not possible to apply this method. In such, — happily only rare cases, — the determination of the specific weight must be given up completely; the same was the case, if the viscosity of the molten mass or its surface-energy surpassed certain limits.

The apparatus used in the determinations of the specific gravities of such molten salts, up to temperatures of 1500° C, had finally, after many alterations and varied constructions, the here described form (fig. 2).

To one of the scales of a sensitive analytical balance a platinum-

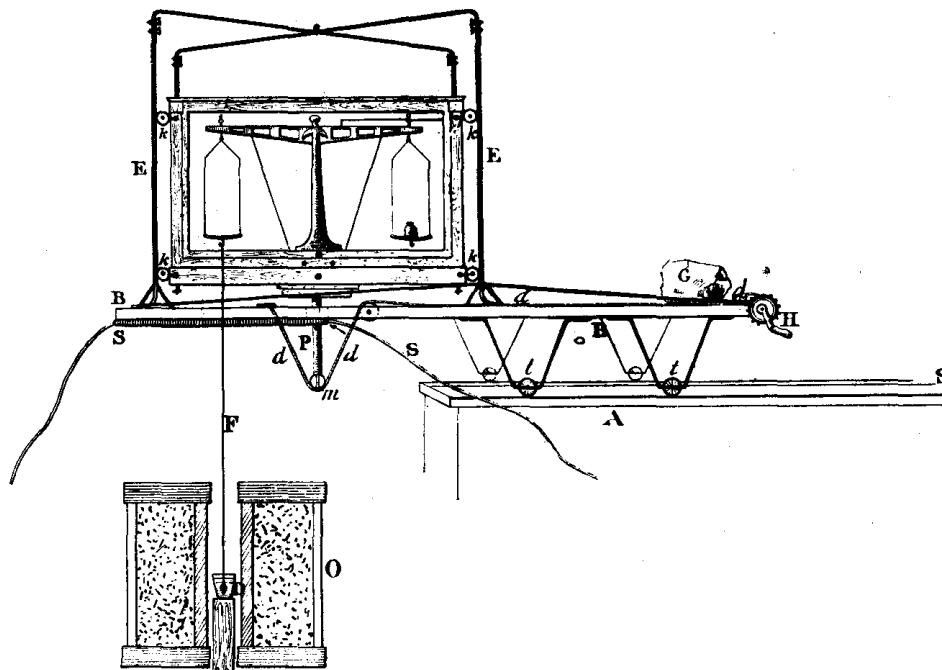

Fig. 2.

wire as thin as possible, *F* (about 80 cm. long) was fixed by means of a small ringlet. For measurements from 1200° to 1600° C., this wire has to be at least 0.3 mm. thick, because it would break

otherwise too easily, the platinum being very soft at such high temperatures. The wire passes through a narrow, cylindrical hole in the bottom of the balance-case, a second hole of the same shape in the board *B*, and a third small canal in the water-screen *S*, which is continuously passed by a stream of cold water, so as to prevent the heat-radiation from the furnace to the balance-case. At its free end the wire bears a massive platinum double-conus *D*, made from iridium-free platinum; this sinker had in our experiments a weight of about 12,1 grams. The balance could move up-and-down by means of four brass pulleys *k*, gliding along the four iron bars *E*; it is supported by a movable pillar *P*, to which at one side also a pulley *m* is fixed, resting on a thin steel cable *d*. By means of a windlass and handle *H* this cable can be shortened or lengthened, the balance being thus moved upwards or downwards. The board *B* can be rolled to and fro by the wheels *t*, moving on the iron rails fixed on *A*; in this way the balance can be placed above the furnace *O*, or, if necessary, it can be removed from it. *G* furthermore is a heavy iron weight, which serves for the equilibrium and stability of the whole apparatus, which in the neighbourhood of the furnace is firmly fixed upon a heavy table.

Now the platinum sinker with wire is weighed in air; then the balance is dropped till the conus is dipped into the liquid, until the surface of this comes to a fix-point on the wire. The temperature of the liquid is determined by means of a thermoelement placed in it quite near to the sinker, by measuring its electromotive force with the potentiometer-arrangement - always used in this laboratory¹⁾. By measuring the force, with which the sinker is driven upwards, if the balance can swing freely, the specific weight of the liquid can be calculated, and all necessary corrections can be taken into account.

The described method was previously tried by means of a number of organic liquids of known density. The result was, that the thus obtained data agreed completely with those obtained by means of the pycnometer, as far as the dependence of the density on the temperature is concerned, moreover also the absolute values appeared to be the same in both cases, if only a correction was taken into account for the capillary influence of the liquid on the wire, which c.p. appeared to be directly proportional to the specific surface-energy χ of the liquid at every temperature. In the case of the wire used by us this correction appeared to be only slightly more than about 0.0001 gram per Erg. This amount must be added

¹⁾ F. M. JAEGER Eine Anleitung zur Ausführung exakter physiko chemischer Messungen bei höheren Temperaturen. Groningen, 1913, p. 16—19.

afterwards to the value found for the force, which drives the sinker upwards. Also in the case of the molten salts KNO_3 , $NaNO_3$, $LiNO_3$, etc. the *absolute* values for d_4^0 appeared to agree with those of GOODWIN and MAILEY¹⁾, if only the observed hydrostatic force was augmented with 0.0001 χ ; the temperature-coefficient of d_4^0 moreover appeared to be independent of this correction too. However, the dates obtained in this way, and especially those at extreme temperatures, can only be considered quite exact in two decimals, and the accuracy never surpasses three or four units of the third decimal. For the proposed purpose this degree of accuracy is sufficient; but, moreover, it may be asked if it is possible at all to obtain more accurate data at such extreme temperatures in some other way? Circumstances are rather unfavourable in these measurements; for an increase of the upwards driving force by the choice of a sinker of greater volume, as GOODWIN and MAILEY did (*loc. cit.*), can hardly be considered a real improvement, because the conduction of an everywhere equal and homogeneously distributed temperature can only be fulfilled by a volume (as small as possible) of the molten mass and of the whole apparatus in the furnace. Only then the furnace can be used as a real thermostat at very high temperatures²⁾. Platinum is, moreover at such high temperatures the only fit material to use; but because of its very high specific weight, the volume of an even very heavy sinker will be only relatively small, and consequently also the observed upwards driving force. There are a number of other disturbing circumstances, e.g. the rather strong damping of the swinging balance, if liquids of appreciable viscosity or surface-tension are investigated; in such cases it is absolutely necessary to keep the liquid at the same temperature for a longer time, if one wishes to be certain of established equilibrium, which must moreover be checked in several ways. All such circumstances diminish the degree of accuracy more or less, so that one may finally be glad to reach the degree of agreement of repeated determinations here mentioned. Especially will this be the case, as most of these molten salts appear to decompose gradually more or less at very high temperatures by, or without, the water-vapour of the atmosphere; their chemical composition being thus altered at the same rate.

Another difficulty again presented itself in measurements of this kind, which is caused by the fact, that most substances possess

¹⁾ GOODWIN and MAILEY, *Physical Review*, **25** 469. (1907); **26**. 28. (1908).

²⁾ F. M. JAEGER, *Eine Anleitung zur Ausführung exakter physiko-chemischer Messungen*, u. s. w. Seite 57, 59, u. s. w.

already a considerable vapour-tension at such high temperatures. The evaporated salt sublimes against the colder parts of the suspension-wire in the form of very small crystals, or as a thin coherent layer; the increase of weight, corresponding with it, makes the upwards-driving force also seem smaller than it really is. It is rather difficult to determine afterwards the correction necessary by it, or even to estimate its magnitude with any certainty.

Although the thus obtained results cannot be considered so accurate as possibly we should wish, we think it, however, wholly justified to consider them as giving a very satisfactory idea of the true specific gravity of this liquids, and to give a sufficiently accurate result for the dependence of the specific gravity on the temperature in the case of these molten salts.

The weight of the platinum conus with the submerged part of the wire, was at 25° C 12,1772 grams (corr.), the specific weight of the platinum at 25° C. was pycnometrically determined at 21,47, and at 0° C. at 21,485. At t° C. it was calculated from the expression.

$$d_{4^{\circ}}^{Pt} = \frac{21,485}{1 + 3(0,000008868 t + 0,000000001324 t^2)}$$

Let P be the weight of the sinker with wire in air, p its weight if submerged in the liquid, then $P-p$ is the upwards driving force, as it *seems* to be. The real force A however is greater, and equal to: $P-p + 0,0001 \gamma_i$.

From this it follows:

$$\frac{A}{P} = \frac{\text{specific weight of the liquid} - \text{specific weight of air}}{\text{specific weight of the platinum}},$$

from which thus the specific weight of the liquid at t° C. follows to be:

$$d_{4^{\circ}}^t = \frac{A \cdot d_i^{Pt}}{12,1772} + 0,001.$$

For all salts the specific gravities were calculated in this way.

§ 3. In the following pages we have shortly reviewed the data thus obtained in the case of a series of salts and other inorganic compounds. Of every salt we have reproduced the figures for three temperatures at least, and we have, moreover, mentioned the general empirical formula, from which the density at other temperatures were intra or extrapolated. We have added the values of the molecular free surface-energies of the liquids at the same temperatures, in Erg per cm^2 , and some remarks on the magnitude of its temperature-

coefficient $\frac{\partial \mu}{\partial t}$. Finally the complete measurements of three inorganic salts not yet previously ¹⁾ described, are reproduced here too.

LiF

t° :	d_{40} :	ν in Erg:	
887°	1.780	1484.5	
973	1.740	1452.1	$d_{40}^t = 1.798 - 0.0004375 (t - 850)$.
1058	1.699	1421.3	

The temperature-coefficient $\frac{\partial \mu}{\partial t}$ increases from about **0,40** Erg per degree between 900° and 1050° to about **0,58** Erg between 1050° and 1200° C.

LiCl.

t° :	d_{40} :	ν in Erg:	
626°	1.490	1274.8	$d_{40}^t = 1.501 - 0.000432 (t - 600)$.
683	1.465	1262.0	
732	1.444	1256.5	

$\frac{\partial \mu}{\partial t}$ has a mean value of about **0,47** Erg per degree.

Li₂SO₄.

t° :	d_{40} :	ν in Erg:	
908°	1.984	3213.5	
1005	1.945	3159	$d_{40}^t = 2.008 - 0.000407 (t - 850)$.
1112	1.901	3100	

$\frac{\partial \mu}{\partial t}$ has a mean value of **0,50** Erg per degree.

LiNO₃.

t° :	d_{40} :	ν in Erg:	
288°	1.762	1336	
341	1.732	1311.2	$d_{40}^t = 1.755 - 0.000546 (t - 300)$.
454	1.770	1260.2	
546	1.621	1212.8	

$\frac{\partial \mu}{\partial t}$ has a mean value of **0,45** Erg per degree.

NaF

t° :	d_{40} :	ν in Erg:	
1017°	1.932	1548.3	
1119	1.875	1501.9	$d_{40}^t = 1.942 - 0.000564 (t - 1000)$.
1214	1.821	1445.1	

$\frac{\partial \mu}{\partial t}$ is rather constant, and has a mean value of **0,52** Erg per degree.

¹⁾ F. M. JÄGGER, these Proceedings 17, 555 and 571, (1914).

NaCl.

t° : d_{40}° μ in Erg:

823° 1.535 1276.5

854 1.516 1259.1 $d_{40}^{t^\circ} = 1.549 - 0.0000626 (t - 800)$.

885 1.496 1244.4

$\frac{\partial \mu}{\partial t}$ has a mean value of about **0.48** Erg per degree.

NaBr.

t° : d_{40}° μ in Erg

787° 2.300 1311.9

829 2.269 1293.0 $d_{40}^{t^\circ} = 2.306 - 0.00072 (t - 780) - 0.0000008 (t - 780)^2$.

880 2.226 1253.4

$\frac{\partial \mu}{\partial t}$ has a mean value of **0.53** Erg per degree.

NaI.

t° : d_{40}° μ in Erg

675° 2.725 1257

699 2.699 1250 $d_{40}^{t^\circ} = 2.698 - 0.001061 (t - 700)$.

724 2.673 1242

$\frac{\partial \mu}{\partial t}$ increases from 0,29 Erg at 750° C, to a mean value of **0,63** Erg between 815° and 860° C.

Na₂SO₄.

t° : d_{40}° μ in Erg:

926° 2.049 3240

988 2.021 3210 $d_{40}^{t^\circ} = 2.061 - 0.000483 (t - 900)$.

1046 1.991 3203

$\frac{\partial \mu}{\partial t}$ can be estimated at about **0,30** Erg per degree.

Na₂MoO₄.

t° d_{40}° μ in Erg.

804° 2.730 3636

931 2.648 3512 $d_{40}^{t^\circ} = 2.795 - 0.000629 (t - 700)$.

1063 2.567 3388

Between 700° and 800° $\frac{\partial \mu}{\partial t}$ is **1,2** Erg per degree, between 800° and 1035° C. it is **0,98** Erg; and between 1035° and 1171° C. it is **0,56** Erg per degree.

Na₂WO₄.

t° : d_{40}° μ in Erg

917° 3.685 3531

1128 3.502 3353 $d_{40}^{t^\circ} = 3.673 - 0.0009275 (t - 930) + 0.000000337 (t - 930)^2$.

1330 3.356 3168

Between 700° and 1000° $\frac{\partial \mu}{\partial t}$ is about **0,64** Erg per degree; between 1515° and 1600° C. it is about **0,98** Erg.

NaNO₃

t°	d_{40}	ν in Erg	
350°	1 880	1502	
400	1.847	1486	
450	1 813	1464	$d_{40}^{t^\circ} = 1.914 - 0.000672(t - 300).$
500	1.780	1442	
550	1.746	1418	

Between 320° and 360° $\frac{\partial \mu}{\partial t}$ is **0,24** Erg, between 350° and 425° C : **0,34** Erg, between 425° and 600° : **0,45** Erg per degree.

NaPO₃

t°	d_{40}	ν in Erg	
905°	2.147	2532	
1007	2.102	2490	$d_{40}^{t^\circ} = 2.193 - 0.00044(t - 800)$

$\frac{\partial \mu}{\partial t}$ is up to 1200° about **0,43** Erg, to 1270° C. **0,61** Erg, and at 1500° C. about **1,1** Erg per degree.

KF.

t°	d_{40}	ν in Erg	
913°	1 869	1368	
986	1.819	1342	$d_{40}^{t^\circ} = 1.878 - 0.000669(t - 900).$
1054	1.775	1310	

Between 900° and 960° $\frac{\partial \mu}{\partial t}$ **0,33** Erg; between 960° and 1060° : **0,45** Erg, and it increases gradually to **0,83** Erg between 1275° and 1310° C

KCl.

t°	d_{40}	ν in Erg	
785°	1.517	1299 0	
837	1.485	1269 3	$d_{40}^{t^\circ} = 1.539 - 0.0005947(t - 750).$
878	1.461	1241.0	

$\frac{\partial \mu}{\partial t}$ is constant, and **0,68** Erg per degree.

KBr.

t°	d_{40}	ν in Erg	
751°	2 105	1286	
776	2.085	1270	$d_{40}^{t^\circ} = 2 106 - 0.000799(t - 750)$
802	2.064	1246	

$\frac{\partial \mu}{\partial t}$ has a mean value of **0,76** Erg per degree.

KI.

t°	d_{40}	ν in Erg	
700°	2 431	1329	
725	2.405	1288	$d_{40}^{t^\circ} = 2.431 - 0.001022(t - 700).$
751	2.378	1247	

Between 730° and 765° $\frac{\partial \mu}{\partial t}$ is **1,58** Erg; between 765° and 815° C. : **0,67** Erg, and at higher temperatures **0,41** Erg per degree.

K₂SO₄

t°	d_{40}^t	μ in Erg	
1102°	1.871	2931	
1202	1.815	2861	$d_{40}^t = 1.872 - 0.000545(t - 1100)$.
1291	1.768	2770	

$\frac{\partial \mu}{\partial t}$ has a mean value of **0,90** Erg per degree Celsius.

K₂Cr₂O₇

t°	d_{40}^t	μ in Erg	
420°	2.271	3620	
463	2.242	3586	$d_{40}^t = 2.285 - 0.000695(t - 400)$.
497	2.217	3575	

Between 480° and 540° C. $\frac{\partial \mu}{\partial t}$ can be estimated to be **0,86** Erg per degree.

K₂MoO₄

t°	d_{40}^t	μ in Erg	
964°	2.342	3227	
1124	2.243	3128	$d_{40}^t = 2.342 - 0.00060(t - 964) - 0.000000128(t - 964)^2$.
1324	2.110	2933	

$\frac{\partial \mu}{\partial t}$ has a mean value of **0,79** Erg per degree.

K₂WO₄

t°	d_{40}^t	μ in Erg	
991°	3.120	3376	
1201	2.954	3051	$d_{40}^t = 3.113 - 0.00082(t - 1000) + 0.000000162(t - 1000)^2$.
1361	2.837	2806	

$\frac{\partial \mu}{\partial t}$ has a mean value of **1,6** Erg per degree.

KNO₃

t°	d_{40}^t	μ in Erg	
394°	1.826	1588	
460	1.774	1538	$d_{40}^t = 1.898 - 0.0007681(t - 300^*)$.
532	1.720	1478	

$\frac{\partial \mu}{\partial t}$ has a mean value of **0,83** Erg per degree

KPO₃

t°	d_{40}^t	μ in Erg	
988°	2.030	2244	
1090	1.986	2172	$d_{40}^t = 2.111 - 0.00043(t - 800)$.
1195	1.941	2074	

Up to 1200° C. $\frac{\partial \mu}{\partial t}$ is constant, and **0,91** Erg per degree; afterwards it increases to about **1,28** Erg per degree.

*) In the Dutch paper this formula contains an error; the numbers given here are the right ones

RbF.

t°	d_{40}°	μ in Erg.	
820°	2.878	1371	
914	2.785	1287	$d_{40}^{t^\circ} = 2.873 - 0.000967(t - 825) - 0.000000247(t - 825)^2$.
1006	2.690	1230	

Between 802° and 887° $\frac{\partial \mu}{\partial t}$ is about **1,0** Erg per degree, between 887° and 1037° C. **0,56** Erg, and afterwards **0,40** Erg per degree.

RbCl.

t°	d_{40}°	μ in Erg.	
734°	2.101	1449	
786	2.059	1400	$d_{40}^{t^\circ} = 2.129 - 0.000823(t - 700)$
822	2.029	1366	

$\frac{\partial \mu}{\partial t}$ is rather constant, and has a mean value of **1,02** Erg per degree.

RbBr

t°	d_{40}°	μ in Erg.	
697°	2.691	1401	
715	2.672	1389	$d_{40}^{t^\circ} = 2.688 - 0.001096(t - 700)$
744	2.640	1366	
780	2.600	1339	

$\frac{\partial \mu}{\partial t}$ is rather constant, and **0,77** Erg per degree.

RbJ.

t°	d_{40}°	μ in Erg.	
700°	2.798	1389	
750	2.742	1338	$d_{40}^{t^\circ} = 2.798 - 0.001107(t - 700)$.
800	2.687	1288	

$\frac{\partial \mu}{\partial t}$ is rather constant, and equal to **0,95** Erg per degree.

Rb₂SO₄.

t°	d_{40}°	μ in Erg:	
1101°	2.528	2923	
1204	2.458	2813	$d_{40}^{t^\circ} = 2.562 - 0.000665(t - 1050)$.
1307	2.391	2735	

Between 1086° and 1112° C $\frac{\partial \mu}{\partial t}$ is **1,98** Erg; between 1112° and 1145°: **1,12** Erg; between 1145° and 1234° C. **0,93** Erg; to 1350° C. **0,72** Erg, to 1334° C. **0,45** Erg; and up to 1550° C. **0,27** Erg per degree Celsius.

RbNO₃

t°	d_{40}°	μ in Erg	
348°	2.446	1626	
445	2.350	1555	$d_{40}^{t^\circ} = 2.492 - 0.000972(t - 300)$.
555	2.245	1470	

$\frac{\partial \mu}{\partial t}$ has a rather constant mean value of **0,78** Erg per degree.

CsF.

t°	d_{40}	μ in Erg.	
720°	3.586	1271	
771	3.522	1239	$d_{40}^{t^\circ} = 3.611 - 0.001234(t - 700)$.
824	3.457	1200	

Originally $\frac{\partial \mu}{\partial t}$ is **0,72** Erg per degree, above 930° C. however it diminishes with increasing temperature to **0,36** Erg at 1100° C.

CsCl.

t°	d_{40}	μ in Erg	
660°	2.775	1380	
701	2.731	1358	$d_{40}^{t^\circ} = 2.786 - 0.00108(t - 650)$.
741	2.688	1278	

Up to 980° $\frac{\partial \mu}{\partial t}$ is about **0,80** Erg per degree, afterwards it increases rapidly **1,17** Erg to 1035° C ; and **1,70** Erg to 1080° C

CsBr.

t°	d_{40}	μ in Erg	
662°	3.109	1362	
702	3.054	1325	$d_{40}^{t^\circ} = 3.125 - 0.00134(t - 650)$
742	3.001	1278	

Between 660° and 700° $\frac{\partial \mu}{\partial t}$ is **0,90** Erg per degree, it then diminishes gradually to about **0,57** Erg between 860° and 970° C.

CsJ.

t°	d_{40}	μ in Erg:	
639°	3.176	1394	
670	3.138	1369	$d_{40}^{t^\circ} = 3.175 - 0.001222(t - 640)$.
701	3.101	1330	

$\frac{\partial \mu}{\partial t}$ has a rather constant mean value of **0,82** Erg per degree.

Cs₂SO₄.

t°	d_{40}	μ in Erg	
1040°	3.034	2687	
1128	2.968	2546	$d_{40}^{t^\circ} = 3.034 - 0.000711(t - 1040) - 0.000000494(t - 1040)^2$.
1220	2.890	2435	

Between 1036° and 1100° C. is $\frac{\partial \mu}{\partial t}$ about 1,91 Erg, between 1100° and 1220° C. **1,16** Erg, between 1220° and 1425° C. **0,70** Erg, and up to 1530° C. about **0,43** Erg per degree.

CsNO₃.

t°	d_{40}	μ in Erg:	
445°	2.774	1532	
481	2.733	1484	$d_{40}^{t^\circ} = 2.824 - 0.001114(t - 400)$.
529	2.680	1431	
575	2.699	1399	

To 600° C. $\frac{\partial \mu}{\partial t}$ has a mean value of **1,18** Erg per degree; afterwards it decreases rapidly to about: **0,42** Erg.

Potassiumbichromate: $K_2Cr_2O_7$					
Temperature in ° C.	Maximum Pressure H		Surface- tension / in Erg per cm ² .	Specific gravity d_{40}	Molecular Surface- energy ν in Erg per cm ² .
	in mm. mer- cury of 0° C.	in Dynes			
420°	4.853	6470	140.1	2.271	—
454	4.825	6433	139.4	2.248	3593
480	4.792	6389	138.4	2.229	3588
504	4.743	6323	137.0	2.213	3568
535	4.672	6229	135.0	2.191	3540

Molecular weight: 294.2. Radius of the Capillary tube: 0.04315 cm. at 18° C.
Depth: 0.1 mm

Above 540° C. a decomposition sets in, while gas is developed. After corrections the specific gravity at 240° C. is 2.271; at 462.7° C.: 2.242; at 497.4° C.: 2.217. Generally at t° C.: $d_{40} = 2.285 - 0.000695(t - 400)$.

The temperature-coefficient of ν has a mean value of about 0.86 Erg per degree, at least between 480° and 535° C.

Thallos Nitrate: $TlNO_3$					
Temperature in ° C.	Maximum Pressure H		Surface- tension / in Erg per cm ² .	Specific gravity d_{40}	Molecular Surface- energy ν in Erg per cm ² .
	in mm. mer- cury of 0° C.	in Dynes			
210°	4.071	5428	117.3	4.899	1681.9
245	3.996	5328	115.2	4.838	1665.7
263.5	3.946	5261	113.8	4.806	1652.8
285	3.884	5178	112.0	4.768	1635.2
312	3.806	5075	109.8	4.721	1613.8
339	3.723	4963	107.4	4.674	1589.0
364	3.645	4860	105.2	4.630	1566.4
389	3.562	4754	102.8	4.586	1540.4
430	3.445	4592	99.5	4.515	1506.5

Molecular weight: 266.01. Radius of the Capillary tube: 0.04315 cm. at 15° C.
Depth: 0.1 mm.

The salt melts at 206° C. to a clear colourless liquid. The specific gravity at 214° C. was: 4.892; at 254° C.: 4.824; at 290° C.: 4.74. At t° C.: $d_{40} = 4.917 - 0.00175(t - 200)$.

The temperature-coefficient of ν is about 0.81 Erg per degree, as a mean value.

Stannous Chloride: SnCl_2 .					
Temperature in ° C.	Maximum Pressure H		Surface- tension γ in Erg per cm^2 .	Specific gravity d_{40}	Molecular Surface- energy μ in Erg per cm^2 .
	in mm. mer- cury of 0° C.	in Dynes			
307°	3.331	4447	97.0	3.289	1449
328	3.298	4397	96.2	3.263	1445
361	3.216	4283	93.9	3.222	1422
377	3.155	4207	92.0	3.202	1402
405	3.048	4064	89.0	3.166	1364
430	2.963	3951	86.4	3.135	1333
452	2.874	3832	83.9	3.108	1302
480	2.796	3728	81.6	3.072	1277

Molecular weight: 189.92. Radius of the Capillary tube: 0.04363 cm. at 18° C.
Depth: 0.1 mm.

The substance was purified by distillation in a stream of dry hydrochloric acid. The salt melts at 250° C. At 290° C. the specific gravity is: 3.310; at 345° C.: 3.241; at 398° C.: 3.174. In general at t° C.: $d_{40} = 3.298 - 0.001253(t - 300)$. The temperature-coefficient of μ has a mean value of about 1.0 Erg per degree.

§ 5. If now we review once more the results obtained in the case of these molten salts (see the following table), it becomes quite clear, that an evident difference in behaviour in comparison with the organic liquids can be stated with respect to the *very small* values of the temperature-coefficient $\frac{\partial \mu}{\partial t}$. While in the case of organic liquids the normal values of $\frac{\partial \mu}{\partial t}$ is about 2.24 Erg per degree Celsius, it is commonly *much smaller* in the case of molten salts, and varies there between 0.3 and 1.0 Erg per degree. Although a special regularity in the magnitude of $\frac{\partial \mu}{\partial t}$ in the different cases can *not* be stated, the mean value of it in the case of homologous salts of the same halogenide seems to show a tendency to increase generally with augmenting atomic weight of the metal. Formerly it has occasionally been concluded from the very small values of $\frac{\partial \mu}{\partial t}$ in the case of molten salts, ¹⁾ that these should be *associated* to a rather high degree. If one assumes, that for such electrolytes indeed the same kind of

¹⁾ BOTTOMLEY, Journ. Chem. Soc. **83**, 1424, (1903); a.o.

<i>Metal:</i>	<i>Fluoride:</i>	<i>Chloride:</i>	<i>Bromide:</i>	<i>Iodide:</i>	<i>Sulphate:</i>	<i>Nitrate:</i>	<i>Molybdate:</i>	<i>Trystate:</i>	<i>Metaphosphate:</i>
<i>Lithium</i>	0.40 tot 0.58	0.47	—	—	0.50	0.45	—	—	—
<i>Sodium</i>	0.52	0.48	0.53	0.29 tot 0.63	0.30	0.24 tot 0.45	1.2 tot 0.56	0.64 tot 0.98	0.43 tot 1.1
<i>Potassium</i>	0.33 tot 0.83	0.68	0.76	1.58 tot 0.41	0.90	0.83	0.79	—	0.91 tot 1.28
<i>Rubidium</i>	1.0 tot 0.40	1.02	0.77	0.95	1.98 tot 0.27	0.78	—	—	—
<i>Caesium</i>	0.72 tot 0.36	0.80 tot 1.7	0.90 tot 0.57	0.82	1.91 tot 0.43	1.18 tot 0.42	—	—	—
<i>Thallium</i>	—	—	—	—	—	0.81	—	—	—
<i>Stannum</i>	—	1.0	—	—	—	—	—	—	—

considerations can be used, as for the organic liquids, this conclusion may appear as a direct and justified consequence of theory. But in our opinion this can hardly be true: for all conclusions based upon the rule of Eötvös, premises implicitly the validity of the law of corresponding states. Now it must appear highly improbable, that this law could hold really in the case of electrolytically dissociated substances as molten salts are, where the degree of dissociation, moreover, varies doubtlessly with the temperature. And if the law of corresponding states for such electrolytes is doubted, then at the same time all arguments lose their validity, which must serve to sustain the view, that the values of $\frac{\partial \mu}{\partial t}$ could prove the associated state of such molten salts.

Moreover we wish to draw attention here to a second fact in the case of these compounds. Formerly ¹⁾ the first of us was able to show, that in the case of the homologous molten *halogenides* of the alcali-metals a *regular* shifting of the χ - t -curves with respect to each other, in connection with the atomic weights of the halogens or of the alcali-metals, can be stated.

It occurs in such a direction, that at a same temperature t the value of χ in every series of halogenides diminishes regularly with the increase of the atomic weight, as well of the alcali-metal, as of the halogen (*loco cit.*). If, however, instead of the mutual situation of the χ - t -curves, that of the μ - t -curves is compared in an analogous way, this regularity appears to have vanished almost totally. Thus e.g. the μ - t -curve for NaF is situated appreciably *higher* than that for LiF , in the case of the *chlorides* the corresponding curve for the *Rb*-salt is situated much *higher* than for the *Na*-salt, this one however again *higher* than in the case of the *K*-salt, while the last curve is *higher* than that for $LiCl$. The precedence in the case of the *bromides*, in a decreasing direction, is: *Rb*, *Na*, and *K*, *Cs*. — both the last mentioned curves almost completely coinciding. For the *iodides* it is in the same way: *Rb*, *Cs*, *K*, *Na*. On the other hand, with the arrangement in the case of the *Li*-salts the μ - t -curve for the *fluoride* appears, — it is true, — *much higher* than that for the *chloride*; but in the case of the *Na*-salts the precedence is in a decreasing sense; *F*, *Br*, *Cl*, *I*; in the case of the *K*-salts in the same way; *F*, *Cl*, *Br*, *I*; with the *Rb*-salts: *Cl*, *F*, *Br*, *I*; and in the case of the *Cs*-salts: *Cl*, *Br*, *I*, *F*.

Nowhere, however, can there be stated a regularity, perfect in any respect.

¹⁾ F. M. JÄGER, these Proceedings, **17**, 555, 571, (1914).

If now it is once more remembered that $\mu = \chi \cdot v^{\frac{2}{3}}$, it must be clear, that the cause of this phenomenon can only be found in the supposition, that v is no longer a comparable thing in these series of homologous salts. A suspicion arises more particularly that it is no longer permissible to take in account for the molecular weight M during the calculation of $v = \frac{M}{d}$, the values, following from the mere chemical formula of these salts. The significance of this would become evident, if one could suppose, that the *degree of dissociation* α of every one of these salts is a *different* one at the *same* temperature. Thus an indirect indication would be found here for the decision of the problem not solved completely up to this date; if molten salts must be considered to be electrolytically dissociated only *partially* or *totally*; and more particularly this question would be definitely answered in favour of the *partial* dissociation, when $\alpha < 1$. In how far this conclusion with respect to this fundamental problem may be considered to be justified, we also hope to discuss shortly in a second way, in connection with experimental data of another kind.

Groningen, Holland, June 1916.

Laboratory for Inorganic and Physical
Chemistry of the University.

Chemistry. — "Investigations on the Temperature-Coefficients of the Free Molecular Surface-Energy of Liquids between -80° and 1650° C. **XVI.** The surface-tension of some Halogenides of Sulphur, Phosphorus, Arsenic, Antimony and Bismuthum". By Prof. Dr. F. M. JAEGER and Dr. JUL. KAHN.

(Communicated in the meeting of June 24, 1916).

§ 1. In the following paper the measurements of the surface-energy are described, which were made with the substances: sulphurmonochloride; phosphorustrichloride; phosphorustribromide, phosphorustriiodide; arsenictrichloride; arsenictribromide; antimonytrichloride; bismuthumtrichloride, and bismuthumtribromide. In the case of antimony-tribromide on heating already immediately a decomposition was observed, the measurements were therefore no longer continued. The determination of the specific gravity of PI_3 appeared not to be possible with the desired accuracy owing to the too rapidly occurring decomposition of the substance under the influence of the water-vapour of the atmosphere.

§ 2.

1.

Sulphurmonochloride: S_2Cl_2 .					
Temperature in ° C.	Maximum Pressure H		Surface- tension γ in Erg per cm^2 .	Specific gravity d_{40}	Molecular Surface- energy μ in Erg per cm^2
	in mm. mer- cury of 0° C.	in Dynes			
0°	1.641	2187.9	45.4	1.709	836.1
25.4	1.513	2017.9	41.8	1.670	781.7
50.1	1.379	1838.8	38.0	1.631	721.9
75	1.259	1678.4	34.6	1.591	668.3
90.5	1.198	1598.3	32.9	1.568	641.7
105.4	1.139	1518.1	31.2	1.544	614.8
121	1.075	1433.2	29.4	1.519	585.7

Molecular weight: 135.06. Radius of the Capillary tube: 0.04242 cm.
Depth. 0.1 mm.

The dark yellow liquid boils under atmospheric pressure at 138° C. At the boilingpoint γ has a value of about: 29.0 Erg The specific weight at 0° C. is 1.7094; at 138° C.: 1.4920 (THORPE).
The temperature-coefficient of μ is originally, up to 50° C. about: 2.24 Erg; afterwards it diminishes to about 1.79 Erg. per degree.

2.

Phosphorstrichloride: PCl_3					
Temperature in ° C.	Maximum Pressure H		Surface- tension γ in Erg per cm^2 .	Specific gravity d_{40}	Molecular Surface- energy μ in Erg per cm^2
	in mm. mer- cury of 0° C.	in Dynes			
-70°	1.574	2098.4	37.4	1.744	687.4
-20.5	1.332	1776.6	31.6	1.653	601.9
0	1.237	1650.2	29.3	1.613	567.3
20.8	1.155	1540.0	27.3	1.574	537.2
35.2	1.093	1457.6	25.8	1.547	513.6
50.3	1.031	1375.0	24.3	1.518	489.9
64.8	0.973	1298.1	22.9	1.492	467.0
75.1	0.932	1243.0	21.9	1.475	450.1

Molecular weight: 137.42. Radius of the Capillary tube: 0.03636 cm.
Depth: 0.1 mm.

The chloride boils under a pressure of 749 mm. at 75° C. Even at -75° C. it is again a thin liquid, but solidifies, according to TIMMERMANS, at -90° C. At the boilingpoint γ has the value: 21.9 Erg. The specific gravity at 16° C. is: 1.582; at 46.2 C.: 1.527; the critical temperature is: 290° C. (RAMSAY and SHIELDS). The temperature-coefficient of μ is relatively small: about 1.61 Erg per degree, as a mean value.

3.

Phosphorustribromide: PBr_3					
Temperature in $^{\circ}C$.	Maximum Pressure H		Surface- tension / in Erg per cm^2 .	Specific gravity d_{40}	Molecular Surface- energy ν in Erg per cm^2 .
	in mm. mer- cury of $0^{\circ}C$.	in Dynes			
-20 $^{\circ}$	1.939	2585.2	45.8	2.972	927.0
0	1.894	2525.1	44.7	2.923	914.8
20.8	1.831	2441.0	43.2	2.871	894.7
35.3	1.795	2392.8	42.3	2.837	883.0
50.3	1.749	2332.2	41.3	2.799	870.0
64.8	1.699	2266.2	40.1	2.762	852.2
75.7	1.650	2200.2	38.9	2.735	832.1
90	1.574	2098.4	37.0	2.701	798.1
99.8	1.526	2035.2	36.0	2.676	781.4
116	1.438	1916.9	33.8	2.636	741.0
125	1.386	1848.1	32.6	2.615	718.5
140	1.295	1727.1	30.4	2.577	676.6
154	1.213	1617.1	28.4	2.542	637.9
170	1.126	1501.7	26.3	2.502	597.0

Molecular weight: 270.6. Radius of the Capillary tube: 0.03636 cm.
Depth: 0.1 mm.

Under a pressure of 750 mm. the compound boils at $170^{\circ}C$. The bromide solidifies at $-50^{\circ}C$., and melts again at $-40^{\circ}C$. At the boilingpoint ν has the value 26.2 Erg.

The temperature-coefficient of ν increases gradually: between -20° and 50° it is: 0.81 Erg; between 50° and $65^{\circ}C$.: 1.22; between 65° and $76^{\circ}C$.: 1.84; between 76° and 100° : 2.03; between 100° and 170° : 2.63 Erg; etc. The specific gravities were calculated from the data given in literature by interpolation.

4.

Phosphorus-Triiodide: PJ_3			
Temperature in $^{\circ}C$.	Maximum Pressure H		Surface- tension / in Erg. per cm^2 .
	in mm. mer- cury of $0^{\circ}C$.	in Dynes	
75.3	1.999	2665.3	56.5
90.9	1.962	2616.9	55.5
105.5	1.931	2574.4	54.6
121.4	1.898	2530.4	53.6
135.5	1.852	2469.1	52.4
150	1.817	2423.4	51.4

Molecular weight: 411.8. Radius of the Capillary tube:
0.04242 cm.
Depth: 0.1 mm.

The red crystals melt at 55° – $60^{\circ}C$.; the compound sublimes rapidly and is so easily attacked by water; that measurements of the specific weight are almost impossible.

5.

Arsenicumtrichloride: $AsCl_3$.					
Temperature in ° C.	Maximum Pressure H		Surface- tension γ in Erg. per cm^2 .	Specific gravity d_{40}	Molecular Surface- energy ν in Erg. per cm^2 .
	in mm. mer- cury of 0° C.	in Dynes			
-21°	1.842	2453.8	43.8	2.245	818.4
0	1.708	2277.2	41.4	2.205	782.9
20.8	1.629	2167.2	39.4	2.165	754.3
35.3	1.601	2134.4	38.0	2.136	734.0
50.2	1.544	2057.3	36.6	2.105	713.9
64.8	1.480	1976.2	35.1	2.073	691.7
75.7	1.445	1924.4	34.2	2.051	678.8
90	1.354	1805.6	32.8	2.016	658.5
110	1.312	1749.0	31.0	1.968	632.4

Molecular weight: **181.34**. Radius of the Capillary tube. 0.03636 cm.
Depth: 0.1 mm.

The chloride boils at 130° 5 C. under a pressure of 757 mm.; its melting-point is -13° C. The specific gravity was calculated from the formula $d_{40} = 2.2050 - 0.001856t - 0.0000027t^2$, derived from the values given in literature. At 0° C. the density is 2.2050; at 20° C.: 2.1668; at 130° 2 C.: 1.9181. The temperaturecoefficient of ν has a mean value of: **1.40** Erg per degree.

6.

Arsenicumtribromide: $AsBr_3$.					
Temperature in ° C.	Maximum Pressure H		Surface- tension γ in Erg per cm^2 .	Specific gravity d_{40}	Molecular Surface- energy ν in Erg per cm^2 .
	in mm. mer- cury of 0° C.	in Dynes			
49.6°	1.822	2429.1	49.6	3.328	1029.5
74.5	1.714	2285.1	46.6	3.261	980.5
90	1.647	2188.1	44.8	3.234	947.8
105.5	1.587	2116.9	43.0	3.184	919.3
121	1.518	2023.8	41.0	3.143	884.1
135	1.467	1956.6	39.6	3.111	859.8
149.6	1.417	1889.1	38.2	3.076	835.6
*165	1.273	1697.6	37.0	3.041	815.6
*179.7	1.244	1658.3	36.1	3.008	801.6

Molecular weight: **314.72**. Radius of the Capillary tube: 0.04242 cm.; in the observations indicated by *, it was: 0.04583 cm.
Depth: 0.1 mm.

Under a pressure of 20 mm. the substance boils at 109° C.; the melting-point is 31° C. At 50° C. the specific gravity was; 3.3282; at 75° C.: 3.2623; at 100° C.: 3.1995. At t° C.: $d_{40} = 3.3972 - 0.002822(t - 25^\circ) + 0.00000248(t - 25^\circ)^2$.

The temperature-coefficient of ν is up to 120° C. fairly constant; its mean value is **2.05** Erg per degree. Afterwards it decreases gradually, and becomes about **0.98** Erg at 180° C.

Antimonytrichloride $SbCl_3$.					
Temperature in ° C.	Maximum Pressure H		Surface- tension ν in Erg per cm^2 .	Specific gravity d_{40}	Molecular Surface- energy ν in Erg per cm^2 .
	in mm. mer- cury of 0° C.	in Dynes			
74.5	1.803	2403.7	49.6	2.672	957.4
90.4	1.739	2319.6	47.8	2.639	930.3
105	1.678	2242.5	46.0	2.606	902.8
120.6	1.616	2148.0	44.3	2.571	877.3
137	1.556	2074.4	42.6	2.534	851.8
149.8	1.506	2008.4	41.2	2.505	830.2
*165	1.342	1789.2	39.6	2.471	805.2
*178	1.299	1732.5	38.3	2.441	785.2

Molecular weight · 226.58. Radius of the Capillary tube 0.04242 cm.; in the observations indicated by *, it was: 0.04583 cm. Depth: 0.1 mm.

The beautifully crystallised compound melts at 73°.2 C.; under a pressure of 20 mm. it boils at 111° C.

The specific gravity can be calculated (KOPP) from the equation: $d_{40} = 2.6712 - 0.002166(t - 75^\circ) - 0.00000072(t - 75^\circ)^2$.

The temperature-coefficient of ν is fairly constant and about 1.66 Erg per degree.

Bismuthchloride: $BiCl_3$.					
Temperature in ° C.	Maximum Pressure H		Surface- tension ν in Erg per cm^2 .	Specific gravity d_{40}	Molecular Surface- energy ν in Erg per cm^2 .
	in mm. mer- cury of 0° C.	in Dynes			
271°	2.271	3028.	66.2	3.811	1254.4
304	2.119	2825	61.8	3.735	1187.0
331	1.994	2658	58.1	3.682	1126.6
353	1.896	2528	55.3	3.621	1084.3
382	1.782	2376	52.0	3.554	1032.4

Molecular weight: 314.38. Radius of the Capillary tube 0.04363 cm. At 18° C. Depth 0.1 mm.

The salt, which melts at 230° C., was purified by distillation in a stream of dry hydrochloric acid. Above 400° C. no reliable measurements were possible, because of the attacking of the platinum capillary tube by the vapours. The measurements can only be considered as approximative ones, because of the partial decomposition of the $BiCl_3$ by the air, which cannot be avoided under these circumstances. The specific weight at 254° C. was: 3.851; at 281° C. · 3.789; at 304° C. 3.735. At t° C. it is $d_{40} = 3.860 - 0.00232(t - 250^\circ)$. The temperature-coefficient of ν is between 271° and 331° C. about 2.14 Erg; between 331° and 353° C.: about 1.92 Erg; and between 353° and 382° C. · 1.78 Erg. per degree Celsius.

Bismuthbromide: $BiBr_3$.					
Temperature in ° C.	Maximum Pressure H		Surface- tension γ in Erg per cm ² .	Specific gravity d_{40}	Molecular Surface- energy ν in Erg per cm
	in mm. mer- cury of 0° C	in Dynes			
250°	2.272	3029	66.5	4.598	1407.6
281	2.172	2893	63.6	4.525	1360.6
299	2.103	2804	61.6	4.471	1328.5
320	2.032	2709	59.5	4.416	1293.8
346	1.936	2581	56.7	4.348	1245.7
370	1.836	2448	53.8	4.286	1191.3
389	1.774	2366	52.0	4.237	1162.3
417	1.668	2224	48.9	4.164	1105.8
442	1.575	2100	46.2	4.099	1055.8

Molecular weight: **447,76.** Radius of the Capillary tube: 0.04381 cm.
at 150 C.
Depth: 0.1 mm.

The salt was prepared from the purest bismuth and bromine, and purified by distillation; it melts at about 250° C. into a yellow liquid, becoming darker at higher temperatures. At 271° C. the density was: 4.572; at 301° C.: 4.466; at 330° C.: 4.390. At t° C. it is generally: $d_{40} = 4.598 - 0.0026(t - 250^\circ)$

The temperature-coefficient of ν increases slowly from **1,76** Erg between 250° and 389°, to about **2,0** Erg per degree at higher temperatures.

§ 3. If now we review the results obtained, on comparison we can derive from them the following conclusions (vid. fig. 1).

Name of the Substance:	Temperature-coefficient of ν :
Sulphurmonochloride	2.24 to 1.79
Phosphorustrichloride	1.61
Phosphorustribromide	0.81 to 2.63
Arsenictrichloride	1.40
Arsenictribromide	2.05 to 0.98
Antimonytrichloride	1.66
Bismuthumtrichloride	2.14 to 1.78
Bismuthumtribromide	1.76 to 2.0

Although the values of $\frac{\partial\mu}{\partial t}$ are not great, and generally *smaller* than the normal value of 2.24 Erg per degree, they are however in all cases appreciably greater than such as occurred in the case of the inorganic molten salts; these values here point in every respect to close analogy with the behaviour of organic liquids.

Specific Surface-Energy
 χ in Erg per cm².

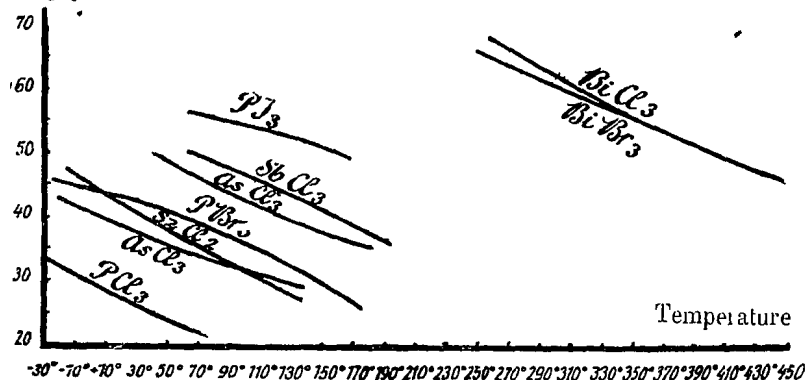

Fig. 1.

Doubtless the influence of the much lower boiling- and melting-temperatures, which are typical for these substances in comparison with the salts mentioned, makes itself felt here.

As for the mutual situation of the χ - t -curves (fig. 1), this appears to be quite regular, just as in the case of the alkali-halogenides, but just *in the reverse direction*, because at the same temperature, χ appears to increase with the atomic weight of the element combined with the halogen. A comparison of the χ - t -curves of PCl_3 , $AsCl_3$, $SbCl_3$ and $BiCl_3$, on one side, and of PBr_3 , $AsBr_3$ and $BiBr_3$, on the other side, shows this immediately. It is remarkable however, that the same is the case here for the halogens: if the χ - t -curves of PCl_3 , PBr_3 and PI_3 are compared with each other, and also those of $AsCl_3$ and $AsBr_3$, and of $BiCl_3$ and $BiBr_3$, — it appears, that at the same temperatures the values of χ are the greater, as the atomic weight of the halogen increases; i.e. just in the reverse direction as formerly was found in the case of the halogenides of the alkali-metals¹⁾. It is very probable that the cause of this striking deviation must be attributed to the much less pronounced contrast in electrochemical character, which the metalloids P , As and Sb show in comparison with the *halogens*, in comparison with that of the strongly electropositive *alkali-metals* against those same halogens,

¹⁾ F. M. JAEGER, These Proceedings 17, 568, 570. (1914).

and the degree of dissociation α (no doubt influenced by it) of the molten alkali-halogenides on one side, and the *P*, *As* and *Sb*-halogenides on the other side.

In the case of the *Bi*-salts, which approach already much more closely to the real metallic salts, the influence of the combined halogen manifests itself immediately in another way: the χ -*t*-curve for *BiBr*₃, although for a greater part coinciding with that of *BiCl*₃, is situated just *beneath* the latter. Previously we found in the case of organic liquids, being also compounds, which do not show an electrolytical dissociation, that the presence of electronegative atom-groups or elements tends generally to increase the values of χ . The specific influence of the substitution of three chlorine-atoms by three bromine-atoms, or of *As* by *Sb*, etc. in the case of these also only slightly associated liquids, perhaps could be thought comparable with the mentioned peculiarity.

For the μ -*t*-curves the same regularities as for χ -*t*-curves, are present in this case; contrary to what was found in the series of the alkali-salts also here the μ -*t*-curves are situated regularly above or beneath each other, all in connection with the atomic weight of the combined elements. The curve for *BiCl*₃ is here certainly situated completely *beneath* that for *BiBr*₃, while those for *AsBr*₃ and *SbCl*₃ are almost coinciding. (fig. 2).

Thus contrary to these of the alkali-halogenides, the μ -*t*-curves

Specific Surface Energy
 μ in Erg per cm².

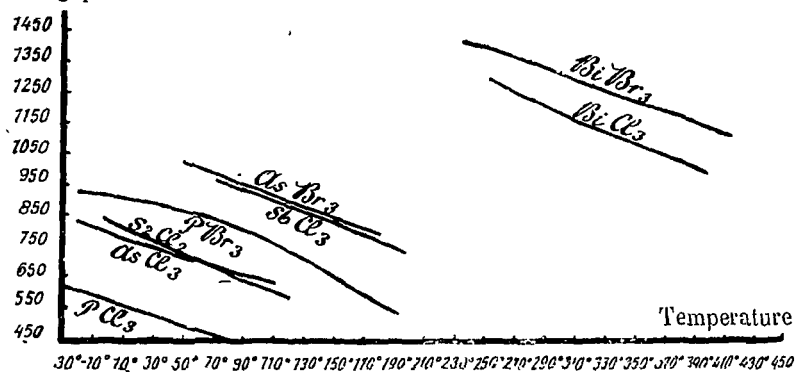

Fig. 2.

are here situated in the *same* arrangement as the χ -*t*-curves; an irregularity like that found in the first case, is not observed here, which evidently is connected with the fact, that no appreciable electrolytic dissociation plays a rôle here.

Laboratory for Inorganic and Physical Chemistry of the University.
Groningen, Holland, June 1916.

Chemistry. — “*Investigations on the Temperature-coefficients of the Free Molecular Surface-Energy of Liquids between -80° and 1650° C.*”: **XVII.** *The relations between the Molecular Cohesion of Liquids at their Melting- and Boilingpoints, and their absolute Melting- and Boiling-temperatures respectively*”.
By Prof. Dr. F. M. JÄGER.

(Communicated in the meeting of June 24, 1916.)

§ 1. Some eight years ago already P. WALDEN¹⁾ drew attention in a number of interesting papers to the remarkable empirical relations, which seem to be present between the capillary constants of non-associated liquids at their boiling- and meltingpoint, and these temperatures themselves, if expressed in terms of the absolute scale.

Starting from the empirically stated rule, according to which the quotient of the heat of evaporation and of the specific cohesion

at the boilingpoint: $\frac{Q}{a^2_b}$, oscillates closely about a mean value of

17,9, if the liquids are not appreciably associated, — he found by combination of this rule with the so-called “rule of TROUTON”, according to which in the case of normal liquids the quotient of the molecular heat of evaporation and of the absolute boiling-

temperature: $\frac{Q}{T_b}$ should be a constant (ω **20,7**), — the relation:

$$\frac{Ma^2_b}{T_b} \omega 1,156.$$

By analogous reasoning WALDEN found also for substances at their meltingpoint a similar relation; the mean value, round which the said quotient oscillates, should in the case of non-associated liquids, be: **3,65**. For associated liquids, however, both mean values should be appreciably *smaller*. Both, of course only approximative empirical rules, may be formulated as follows:

At the melting- and boilingpoint of the substances the quotients of the molecular cohesion and the absolute melting-, respectively boiling-temperatures themselves, are almost constant for non-associated liquids.

WALDEN checked these conclusions by means of a number of cases, collected from literature; and he found them really confirmed, at least within certain limits. However, in the case of the inorganic salts no such mean value could be derived from the older data in literature.

§ 2. It seemed interesting to test these relations once more by

¹⁾ P. WALDEN, Zeits. f. phys. Chemie **65**, 257 (1909); Zeits. f. Elektrochem. **14**, 713, (1908).

§ 3. FIRST GROUP.

Chemical Compound:	Absolute Melting-temperature:	Specific Cohesion α^2 at the Meltingpoint:	K_m :	Absolute Boiling-temperature: ($p = 1$ atm.)	Specific Cohesion α^2 at the Boilingpoint:	K_b :
<i>Chloroform</i>	213 ^o	4.79	2.69	334.2 ^o	3.14	1.12
<i>Carbon tetrachloride</i>	253	3.77	2.05	349.4	2.72	1.20
<i>Ethylene chloride</i>	238	6.04	2.51	359	3.99	1.08
<i>Ethylidene chloride</i>	176.4	5.78	3.24	333.9	3.56	1.05
<i>Ethylodide</i>	162.1	3.87	3.64	345.5	2.49	1.10
<i>Acetylene tetrachloride</i>	229	5.19	3.80	419.5	2.94	1.18
<i>Acetylene tetrabromide</i>	270	3.47	4.44	—	—	—
<i>Isobutylbromide</i>	—	—	—	363.5	3.08	1.16
<i>Carbonbisulphide</i>	161.4	7.00	3.30	319.8	4.54	1.08
<i>Glycerol</i>	292	ca. 11	3.3	563	6.78	1.11
<i>Diethylether</i>	156.8	8.20	3.88	307.8	4.65	1.12
<i>Trichloroacetic Acid</i>	330.5	3.71	1.82	468	2.64	0.92
<i>Ethylchloroformiate</i>	—	—	—	364.5	3.88	1.15
<i>Ethylacetate</i>	189.6	7.58	3.52	350.1	4.26	1.07
<i>Amylacetate</i>	—	—	—	421.4	3.82	1.18
<i>Methylisobutyrate</i>	—	—	—	364.8	4.20	1.18
<i>Ethylisobutyrate</i>	—	—	—	383.2	3.75	1.14
<i>Isobutylisobutyrate</i>	—	—	—	420.2	3.37	1.16
<i>Glyceryltri formiate</i>	291	7.42	4.49	539	3.17	1.03
<i>Ethyl-acetyloacetate</i>	—	—	—	452.6	3.83	1.10
<i>Ethyl-propylacetyloacetate</i>	—	—	—	496.6	3.30	1.14
<i>Methylcyanoacetate</i>	—	—	—	476	4.33	0.90
<i>Ethylcyanoacetate</i>	250.5	7.45	3.36	479	4.18	0.99
<i>Propylcyanoacetate</i>	234	7.57	4.11	489	3.96	1.03
<i>Butylcyanoacetate</i>	—	—	—	503.5	4.20	1.18
<i>Isobutylcyanoacetate</i>	247	6.82	3.90	496	3.69	1.05
<i>Amylcyanoacetate</i>	—	—	—	513.2	3.98	1.20
<i>Diethyloxalate</i>	232.5	6.78	4.26	458	3.31	1.06
<i>Diethylmalonate</i>	223	6.98	5.01	470.8	3.23	1.09
<i>Dimethylsuccinate</i>	291.2	6.29	3.16	468.3	3.31	1.03
<i>Diethyltartrate</i>	288	6.50	4.67	553	3.14	1.16
<i>Acetone</i>	278.7	6.24	1.30	329	5.22	0.92

FIRST GROUP, (continued).

Chemical Compound:	Absolute Melting-temperature:	Specific Cohesion α^2 at the Meltingpoint:	K_m :	Absolute Boiling-temperature: ($p = 1$ atm.)	Specific Cohesion α^2 at the Boilingpoint:	K_b :
<i>Acetylacetone</i>	243°	6.99	2.86	410.5	4.28	1.04
<i>Methylpropylcetone</i>	189.5	7.88	3.58	375.3	4.45	1.02
<i>Trimethylamine</i>	—	—	—	270	5.21	1.14
<i>Diethylamine</i>	234.1	6.44	2.01	329	4.74	1.05
<i>Triethylamine</i>	158.3	8.20	5.24	362	4.00	1.12
<i>norm. Propylamine</i>	—	—	—	320.5	5.16	0.95
<i>Dipropylamine</i>	228	7.28	3.23	383.5	4.04	1.07
<i>Isopropylamine</i>	—	—	—	308	4.80	0.92
<i>Allylamine</i>	—	—	—	327	5.65	0.99
<i>norm. Butylamine</i>	227	7.27	2.34	351	4.80	1.00
<i>Isobutylamine</i>	—	—	—	341	5.00	1.07
<i>Dusobutylamine</i>	—	—	—	415	3.53	1.10
<i>3^{ar} Butylamine</i>	219	6.63	2.21	317	4.56	1.05
<i>norm. Anylamine</i>	235	6.90	2.56	377	4.58	1.06
<i>Isoanilamine</i>	—	—	—	370	4.55	1.07
<i>Dusoanilamine</i>	229	7.19	4.94	461	3.17	1.08
<i>3^{ar} Anilamine</i>	—	—	—	349.5	4.37	1.09
<i>norm. Hexylamine</i>	254	7.14	2.84	403	4.94	1.24
<i>Isohexylamine</i>	—	—	—	397	4.84	1.23
<i>norm. Heptylamine</i>	255	6.96	3.14	427	4.28	1.15
<i>Capronitrile</i>	228	7.08	2.95	430	4.19	0.94
<i>Benzene</i>	278.4	7.04	1.97	353.5	5.22	1.15
<i>Cyclohexane</i>	281	7.37	2.21	353.7	4.74	1.13
<i>Toluene</i>	178.5	ca. 10	5	382.4	5.09	1.23
<i>p-Xylene</i>	288	7.14	2.63	409.2	4.67	1.21
<i>Mesitylene</i>	227	7.84	4.15	435.8	4.26	1.17
<i>Pseudocumene</i>	212.5	8.07	4.56	441.5	4.45	1.21
<i>Triphenylmethane</i>	365	7.26	4.86	—	—	—
<i>Nitrobenzene</i>	276	7.47	3.36	482	4.48	1.07
<i>o-Dinitrobenzene</i>	390	6.09	2.62	—	—	—
<i>m-Dinitrobenzene</i>	364	6.38	2.95	565	4.69	1.39

FIRST GROUP, (continued).

Chemical Compound:	Absolute Melting-temperature:	Specific Cohesion α^2 at the Meltingpoint:	K_m :	Absolute Boiling-temperature: ($p = 1$ atm.)	Specific Cohesion α^2 at the Boilingpoint:	K_b :
<i>Azoxybenzene</i>	309°	7.22	4.63	—	—	—
<i>m-Fluoronitrobenzene</i>	272	6.08	3.15	470.5	3.80	1.14
<i>p-Fluoronitrobenzene</i>	299.5	5.87	2.76	477	3.50	1.03
<i>Chlorobenzene</i>	308	5.91	2.16	404	3.92	1.09
<i>m-Dichlorobenzene</i>	254	6.29	3.64	445.5	4.00	1.32
<i>p-Dichlorobenzene</i>	325	4.92	2.22	446.5	3.56	1.17
<i>o-Chloronitrobenzene</i>	306	6.22	3.20	514	3.65	1.12
<i>m-Chloronitrobenzene</i>	317.5	6.01	2.98	509	3.66	1.13
<i>p-Chloronitrobenzene</i>	356	5.50	2.43	507	3.81	1.18
<i>1-2-4-Chlorodinitrobenzene</i>	324	6.26	3.91	—	—	—
<i>1-2-Dichloro-4-Nitro-benzene</i>	316	5.51	3.35	—	—	—
<i>1-3-Dichloro-4-Nitro-benzene</i>	307	5.68	3.55	—	—	—
<i>1-4-Dichloro-2-Nitro-benzene</i>	328	5.41	3.17	540	3.14	1.12
<i>Bromobenzene</i>	243	5.75	3.71	427	3.29	1.21
<i>p-Fluorobromobenzene</i>	—	—	—	423	3.09	1.28
<i>o-Bromonitrobenzene</i>	316	5.17	3.30	531.5	3.13	1.19
<i>m-Bromonitrobenzene</i>	329.5	5.00	3.06	524	3.24	1.25
<i>p-Dibromobenzene</i>	362	3.60	2.34	489	2.48	1.20
<i>Iodobenzene</i>	247	4.47	3.69	461.5	2.29	1.01
<i>o-Iodonitrobenzene</i>	323	4.62	3.56	—	—	—
<i>m-Iodonitrobenzene</i>	309	4.76	3.84	—	—	—
<i>o-Nitrotoluene</i>	269	7.55	3.85	491	3.80	1.06
<i>p-Nitrotoluene</i>	330.5	6.56	2.72	509	3.88	1.05
<i>o-Bromotoluene</i>	246	5.41	3.76	452	3.06	1.16
<i>m-Fluorotoluene</i>	—	—	—	387.5	4.43	1.26
<i>p-Chlorotoluene</i>	280.5	6.61*	2.98	435.5	4.43	1.29
<i>Phenol</i>	314	7.11	2.13	453.5	4.73	0.98
<i>o-Nitrophenol</i>	318	6.09	2.66	487.5	3.54	1.01
<i>m-Nitrophenol</i>	369	6.46	2.43	—	—	—
<i>p-Nitrophenol</i>	386	6.98	2.51	—	—	—
<i>1-2-4-Dinitrophenol</i>	387	5.94	2.83	—	—	—
<i>2-4-6-Trichlorophenol</i>	342.5	4.98	2.27	519	3.17	1.21

FIRST GROUP, (continued).

Chemical Compound:	Absolute Melting-temperature:	Specific Cohesion α^2 at the Meltingpoint:	K_m :	Absolute Boiling-temperature: ($p = 1$ atm.)	Specific Cohesion α^2 at the Boilingpoint:	K_b :
<i>Thymol</i>	324.5°	6.49	3.00	504.5°	4.10	1.32
<i>Anisol</i>	236	8.10	3.71	424.7	4.67	1.18
<i>o-Nitro-anisol</i>	283	8.04	4.35	545	3.23	0.91
<i>p-Nitroanisol</i>	328	6.90	3.22	532	4.04	1.16
<i>Phenetol</i>	240	7.59	3.86	441	4.29	1.19
<i>p-Nitrophenetol</i>	333	6.47	3.25	556	3.80	1.14
<i>o-Cresol</i>	303	6.97	2.49	463.2	4.43	1.03
<i>p-Cresol</i>	310	6.69	2.33	473	4.15	0.95
<i>Anethol</i>	294.5	7.53	3.79	503.5	4.26	1.25
<i>Guajacol</i>	295	7.74	3.15	—	—	—
<i>Resorcinoldimethylether</i>	221	8.57	5.4	487.5	4.45	1.26
<i>Hydroquinonedimethylether</i>	329	6.97	2.93	—	—	—
<i>Veratrol</i>	295	7.44	3.48	479	4.42	1.27
<i>4-5-Dinitroveratrol</i>	403.5	6.31	3.57	—	—	—
<i>Methylbenzoate</i>	260.5	7.83	4.09	468.2	4.41	1.28
<i>Ethylbenzoate</i>	239	7.55	4.74	483.8	3.84	1.19
<i>Methylsalicylate</i>	264.5	7.20	4.14	496	3.87	1.19
<i>Ethylsalicylate</i>	263	7.01	4.43	504.2	3.75	1.24
<i>Salol</i>	315	7.27	4.94	—	—	—
<i>Methylcinnamylate</i>	319.5	7.52	3.94	526.5	4.20	1.29
<i>Ethylcinnamylate</i>	279.5	7.36	4.64	543	3.62	1.18
<i>Acetophenone</i>	293.5	8.09	3.31	474.5	5.30	1.34
<i>Salicylaldehyde</i>	266	7.86	3.61	465.5	5.01	1.31
<i>Anisaldehyde</i>	275.5	7.98	3.94	520	4.26	1.11
<i>Benzophenone</i>	321.5	7.54	4.27	578	4.24	1.01
<i>2-4-2'-4'-Tetrachlorobenzophenone-dichloride</i>	413	4.48	4.07	—	—	—
<i>Aniline</i>	267	9.00	3.14	457	5.70	1.16
<i>m-Nitroaniline</i>	385	7.35	2.63	559	5.23	1.29
<i>o-Chloroaniline</i>	273	7.18	3.35	483.5	4.76	1.25
<i>p-Chloroaniline</i>	343	6.68	2.48	505	4.82	1.22
<i>Monomethylaniline</i>	216	8.94	4.43	468.5	5.03	1.15

FIRST GROUP, (continued).

Chemical Compound:	Absolute Melting-temperature:	Specific Cohesion α^2 at the Meltingpoint:	K_m :	Absolute Boiling-temperature: ($p = 1$ atm.)	Specific Cohesion α^2 at the Boilingpoint:	K_b :
<i>p</i> -Nitro-monomethylaniline	425°	7.89	2.82	—	—	—
Dimethylaniline	273.5	8.35	3.69	4.92°	464	1.28
Diisobutylaniline ¹	—	—	—	3.00	523	1.18
<i>o</i> -Toluidine	250	9.07	3.89	4.84	470.4	1.10
<i>3</i> -Nitro- <i>o</i> -toluidine	369	6.80	2.80	—	—	—
<i>5</i> -Nitro- <i>o</i> -toluidine	401	7.97	3.02	—	—	—
<i>3</i> -Nitro- <i>p</i> -toluidine	390	6.40	2.50	—	—	—
Diphenylamine	327	7.56	3.93	—	—	—
Pyridine	221	8.73	2.97	387.5	5.78	1.12
Piperidine	264	7.23	2.33	381	4.90	1.09
<i>o</i> -Picoline	209	9.18	4.09	406.5	5.30	1.21
Chinoline	250.4	8.93	4.60	506	5.00	1.28
Sylvestrene	—	—	—	450	2.98	0.90
Terebene	—	—	—	443	3.78	1.16
Furfurol	242	7.80	3.10	435	5.04	1.11
Thiophene	234	6.80	2.35	360	4.71	1.10
Epichlorohydrine	225	7.28	2.98	390	4.68	1.11

SECOND GROUP.

Water	273°	15.48	1.02	373°	12.44	0.60
Methylalcohol	176	7.22	1.31	338.5	5.09	0.48
Ethylalcohol	159	7.59	2.20	351.4	4.70	0.61
norm. Propylalcohol	—	—	—	369.7	4.84	0.79
Isobutylalcohol	—	—	—	379.8	4.61	0.89
Formic Acid	279	6.31	1.04	374	5.29	0.65
Acetic Acid	289.8	5.40	1.12	391.1	3.72	0.57
Monochloroacetic Acid	335.5	5.14	1.45	460	3.77	0.78
Dichloroacetic Acid	283	4.79	2.16	465.5	3.04	0.84
Ethylformate	192.5	7.56	1.97	327.3	4.69	0.72
Methylamine	—	—	—	267	6.31	0.73
Dimethylamine	—	—	—	280.5	5.30	0.85

SECOND GROUP, (continued).

Chemical Compound.	Absolute Melting-temperature:	Specific Cohesion α^2 at the Meltingpoint:	K_m .	Absolute Boiling-temperature: ($p = 1$ atm.)	Specific Cohesion α^2 at the Boilingpoint:	K_b :
<i>Ethylamine</i>	189.2°	7.75	1.85	293°	5.76	0.89
<i>Tripropylamine</i>	—	—	—	430	3.35	0.79
<i>Formamide</i>	268	10.5	1.76	468	8.1	0.78
<i>Nitromethane</i>	249	6.86	1.64	375	4.98	0.81

THIRD GROUP.

<i>Glyceryltriacetate</i>	—	—	—	533°	3.28	1.34
<i>Glyceryltributyrate</i>	—	—	—	559	3.02	1.63
<i>Glyceryltricaprylate</i>	282°	6.33	10.6	—	—	—
<i>Glyceryltricaproate</i>	213	6.75	12.2	—	—	—
<i>Glyceryltricaprinat</i>	304.1	6.13	11.4	—	—	—
<i>Glyceryltrilaurinate</i>	319.5	6.84	13.5	—	—	—
<i>Glyceryltripalmitate</i>	338.1	7.06	16.7	—	—	—
<i>Glyceryltristearate</i>	344.6	7.09	17.7	—	—	—
<i>Glyceryltrioleate</i>	ca. 256	8.6	29.7	—	—	—
<i>Dimethyltartrate</i>	321	6.71	3.72	553	4.57	1.47
<i>Levulinic Acid</i>	306	7.06	2.68	426.5	5.90	1.60
<i>Nitrosomethylamine</i>	286	8.00	3.81	401	6.48	2.19
<i>Benzylbenzoate</i>	286	7.93	5.88	581	5.17	1.89
<i>Trisobutylamine</i>	249	6.28	4.67	462	3.50	1.40

INORGANIC COMPOUNDS *)

<i>Sulphurmonoxide</i>	197°	ca. 6.3	4.2	411°	3.77	1.23
<i>Phosphorustrichloride</i>	183	4.55	3.41	349	3.02	1.17
<i>Phosphorustribromide</i>	233	3.16	3.66	443	3.57	2.18
<i>Arsenictrichloride</i>	260	4.19	2.93	403.5	3.10	1.36
<i>Arsenictribromide</i>	304	3.13	3.22	494	2.30	1.45

*) Where no special meltingpoint-determinations have been made by us, the best data from literature are used. The little differences of these meltingpointdata are of no importance for the determination of the order of magnitude of K .

INORGANIC COMPOUNDS, (continued).

Chemical Compound :	Absolute Melting-temperature	Specific Cohesion α^2 at the Meltingpoint:	K_m	Absolute Boiling-temperature : ($p = 1$ atm.)	Specific Cohesion α^2 at the Boilingpoint:	K_b
<i>Antimonytrichloride</i>	346.2	3.79	2.46	496	2.94	1.29
<i>Bismuthumtrichloride</i>	506	3.78	2.35	—	—	—
<i>Bismuthumtribromide</i>	490	2.96	2.70	726	2.28	1.40
<i>Stannochloride</i>	523	3.04	1.10	876	ca. 4.9	ca. 1.1
<i>Lithiumfluoride</i>	1117	28.4	0.06	—	—	—
<i>Lithiumchloride</i>	887	18.8	0.89	—	—	—
<i>Lithiumsulfate</i>	1122	22.7	2.22	—	—	—
<i>Lithiumnitraat</i>	527	13.5	1.75	—	—	—
<i>Sodiumfluoride</i>	1253	21.14	0.70	—	—	—
<i>Sodiumchloride</i>	1074	14.9	0.81	—	—	—
<i>Sodiumbromide</i>	1034	9.29	0.92	—	—	—
<i>Sodiumiodide</i>	936	6.51	1.08	—	—	—
<i>Sodiumsulphate</i>	1157	19.4	2.39	—	—	—
<i>Sodiummolybdate</i>	960	15.6	3.34	—	—	—
<i>Sodiumwolframate</i>	967	10.66	3.20	—	—	—
<i>Sodiumnitrate</i>	581	12.8	1.86	—	—	—
<i>Sodiummetaphosphate</i>	892	18.8	1.46	—	—	—
<i>Potassiumfluoride</i>	1129	15.2	0.78	—	—	—
<i>Potassiumchloride</i>	1041	13.0	0.93	—	—	—
<i>Potassiumbromide</i>	1006	8.54	1.01	—	—	—
<i>Potassiumiodide</i>	954	6.49	1.13	—	—	—
<i>Potassiumsulphate</i>	1340	15.5	2.01	—	—	—
<i>Potassiumbichromate</i>	669	13.0	5.71	—	—	—
<i>Potassiummolybdate</i>	1192	13.0	2.60	—	—	—
<i>Potassiumwolframate</i>	1194	10.3	2.81	—	—	—
<i>Potassiumnitrate</i>	612	12.4	2.05	—	—	—
<i>Potassiummetaphosphate</i>	1083	20.7	2.25	—	—	—
<i>Rubidiumfluoride</i>	1033	9.24	1.02	—	—	—
<i>Rubidiumchloride</i>	999	9.46	1.13	—	—	—
<i>Rubidiumbromide</i>	956	6.86	1.19	—	—	—
<i>Rubidiumiodide</i>	915	5.83	1.34	—	—	—

INORGANIC COMPOUNDS, (continued).

Chemical Compound :	Absolute Melting-temperature :	Specific Cohesion α^2 at the Meltingpoint:	K_m	Absolute Boiling-temperature: ($p = 1$ atm.)	Specific Cohesion α^2 at the Boilingpoint:	K_b :
<i>Rubidiumsulphate</i>	1347	10.73	2.04			
<i>Rubidumnitrate</i>	579	8.91	2.24			
<i>Caesiumfluoride</i>	953	6.03	0.96			
<i>Caesiumchloride</i>	919	6.60	1.20			
<i>Caesiumbromide</i>	909	5.42	1.27			
<i>Caesiumiodide</i>	894	4.80	1.39			
<i>Caesiumsulphate</i>	1292	7.59	2.13			
<i>Caesiumnitrate</i>	687	6.78	1.92			
<i>Thallionitrate</i>	479	4.89	2.69			

means of the so much more extensive experimental material at our disposal now ¹⁾. For the purpose of easier comparison these experimental data are subdivided into four groups: the first group includes all substances, where the mentioned rule, as far as it concerns the *boiling-temperature*, seems to have indeed an approximative validity; it contains **121** compounds. The second group concerns those organic liquids, where the value of K_b is appreciably *smaller*, and **16** liquids are dealt with; while in the third group **14** liquids are collected, for which the mean value is much *greater* than **1.15**. Finally in a fourth group we have dealt with **48** inorganic compounds and metallic salts.

§ 4. If now we review the results of these calculations, it appears first of all once more, that no complete "law", but only an approximative rule is present here. In the first group the mean value of K_b is **1.12**, and for K_m it is **3.38**; thus the mean value at the meltingpoint is *three times* that at the boilingpoint. In 12 or 17% of the cases considered, dealing with **121** substances for the boilingpoints, and **118** for the meltingpoints, there are rather appreciable deviations from this mean value stated: at the boiling-

¹⁾ The number for α^2 therein is calculated from: $\frac{2\gamma}{gd}$ at the melting, or boilingpoint

point the greatest differences can reach 16 %, at the meltingpoints in some cases even 58 % of this mean value. In every case the rule holds at the boilingpoint evidently much better than at the meltingpoint, — which could be expected beforehand. In group II we find: *water*, the *alcools*, the *acids*, and a number of aliphatic *amines*, — all substances for which association is also very probable as concluded from other phenomena. In group III we find i.a. the neutral *glycerides* of the fatty acids; it is very difficult to give a sufficient explanation for the very high values K_b in these cases, but it seems that the extremely great molecular weights of these compounds play a certain role in the results of the calculations. Abnormally small however, and without any regularity, are the values for K_m in the case of the molten inorganic salts; in this respect it is worth attention, that in the series of the alkali-halogenides, K_m seems to increase in general with increasing atomic weight of the halogen. These inorganic salts are thus evidently to be grouped apart, and they are certainly deviating further from the organic liquids, than e.g. such is the case with the halogenides of *P* and *As*.

	<i>Li</i>	<i>Na</i>	<i>K</i>	<i>Rb</i>	<i>Cs</i>
<i>F</i>	0.66	0.70	0.78	1.02	0.96
<i>Cl</i>	0.89	0.81	0.93	1.13	1.20
<i>Br</i>	—	0.92	1.01	1.19	1.27
<i>I</i>	—	1.08	1.13	1.34	1.39

Generally speaking, we can thus say that in by far the greatest number of organic compounds, the empirical rules of WALDEN are *confirmed* by experiment, and that the mean value at the meltingpoint is very closely *three* times that at the boilingpoint. However it may appear doubtful, if it is right to conclude about the *degree* of association of these liquids, from the deviations, which are observed with respect to the adopted mean values.

*Laboratory for Inorganic and
Physical Chemistry of the University.*

Groningen, Holland, June 1916.

Physics. — “*On the influence of an electric field on the light transmitted and dispersed by clouds.*” By C. M. HOOGENBOOM.
(Communicated by Prof. ZEEMAN.)

(Communicated in the meeting of June 24 1916).

1. *Introduction.* The researches, which will be communicated here and which will be treated more completely in my dissertation, are the continuation of the experiments of Prof. ZEEMAN and HOOGENBOOM, the results of which have been published already in these Proceedings ¹⁾.

They refer to the double refraction some clouds, especially of ammonium chloride, show in an electric field and to the influence of the electric field on the intensity of the transmitted and the dispersed light.

BLOCH ²⁾ has been the first to remark some action of the field on the propagation and the dispersion of light in and by a cloud of ammonium chloride. The details of this phenomenon have then been investigated by Prof. ZEEMAN and the author, by which research was found that such a cloud shows dichroism as well as double refraction. As to the double refraction it was found that a recently formed cloud is positively double refracting, while after some time it becomes negatively double refracting. This change we then connected with the dimorphism of ammonium chloride, which after having been observed probably for the first time by STAS, has recently drawn more attention.

Until now somewhat accurate measurements on the electric double refraction of ammonium chloride had not been made. This has been done now and the results of this research have been given in the first part of this communication. Further the dispersion phenomena of the double refraction and the results reached with other nebulae will be discussed.

In the second part those phenomena are discussed in which the field acts on the *intensity* of the transmitted and the dispersed light. A first observation of this kind has been made by BLOCH. The dichroism too belongs to this group of phenomena; further the authors had found already earlier, that in a direction perpendicular to the lines of force the transmitted natural light is weakened by the field.

Now a more complete research has been made where all cases

¹⁾ ZEEMAN and HOOGENBOOM, These Proceedings XIV p. 558 and 786, XV p. 178. These papers will be referred to as Communication I, II and III. See also Phys. Zs **13**, 913, 1912.

²⁾ BLOCH C. R. **146** 970. 1908.

have been treated systematically, the results of which are given here together.

I. *Electric double refraction in clouds of ammonium-chloride and other substances.*

Dispersion phenomena.

2. *Arrangement.* The arrangement used for the investigation of clouds of ammonium chloride is essentially the same which has formerly been used by Prof. ZEEMAN and the author. Fig. 1 represents

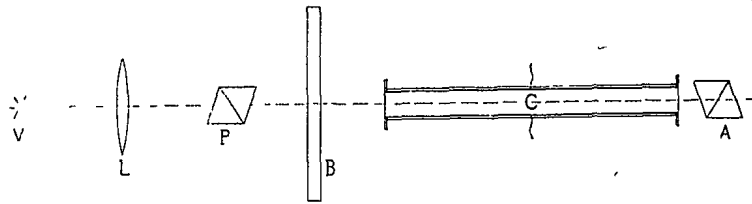

Fig. 1.

it schematically. The light of the source V is rendered parallel by a lens L. This parallel beam then traverses successively the polarizer P, a curved glass bar B, which serves as compensator, the condenser vessel with ammonium chloride, in which an electric field can be excited, and the analyzer A. The nicols are crossed, their polarization directions make angles of $\pm 45^\circ$ with those of the electric force. Looking through the analyzer we see the neutral line of the bar as a black band in a light field. Double refraction of the ammonium chloride will now be revealed by a displacement of the band towards the place where it is compensated. Dichroism will weaken the band or cause it quite to vanish.

Some particulars will be discussed in details.

The ammonium chloride was contained in a glass *condensator vessel* nearly equal to that, which was described before.¹⁾ For the measurements however it was altered in so far that the leaves of tinfoil which serve as condensator plates are applied to the inner side of the glass.

The ammonium chloride was again formed in the vessel from NH_3 and HCl.

For the *electric field* I could dispose of a Wimshurst machine and of two transformers.

The *Wimshurst* was driven by a three phase motor of about $\frac{1}{4}$

¹⁾ ZEEMAN and HOOGENBOOM, Communication I.

horse power. In order to obtain constant potential differences the

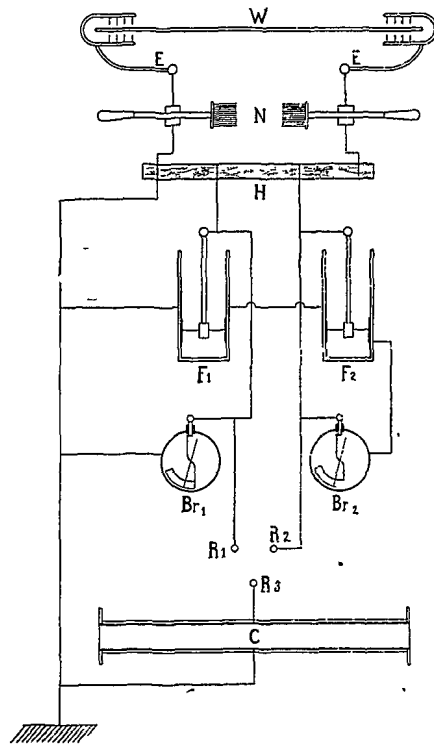

Fig. 2.

W the Wimshurst, EE the electrodes, N the needle-systems, H the wooden stick, F₁ and F₂ Leyden jars, Br₁ and Br₂ electrometers of BRAUN, R₁, R₂ and R₃ clamps of a key, C the condenser vessel.

two electrodes were connected with two needle systems in front of each other, while further a large resistance, a small wooden stick, was inserted between one electrode of the electrical machine and one of the plates of the condenser vessel.

The other electrode and the other plate were earthed. Moreover a Leyden jar of great capacity had been connected in parallel with the condenser vessel. In this way satisfying results were reached. When during the research it proved to be necessary, that two different potential differences could be worked with soon after each other, the arrangement was altered a little bit. It now became as is shown by fig. 2.

For experiments with an *alternating* field I could dispose of two transformers. One of these transformers (Tr₁) could transform the tension of the municipal net of 110 volt to 10.000 volt, the other (Tr₂) to 50.000.

If in the case of an alternating

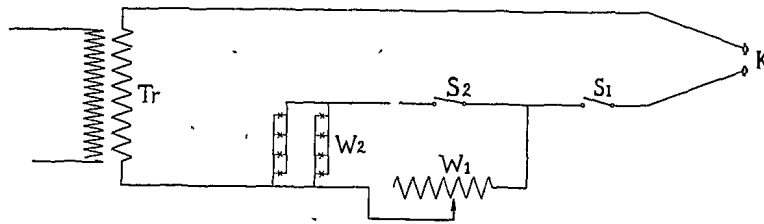

Fig. 3.

- K clamps of the transformerboard, S₁ and S₂ switches, W₁ large resistance, W₂ small (lamp-) resistance, Tr transformer.

field observations at different potential differences had to be made soon after each other, the arrangement of fig. 3 was used. Here the primary circuit only has been indicated; the condenser vessel

forms part of the secondary circuit. By first shutting the switch S_1 and then S_2 , we obtain in a simple way between the ends of the secondary circuit very different potential differences soon after another at least if the resistances W_1 and W_2 are very different from each other.

Electrometers of BRAUN were used to measure the tension. They had been calibrated before. The curved glass bar was again very useful as a sensitive *compensator* by means of which differences in phase of $6 \times 10^{-5} \lambda$ may still be detected, as has been found formerly.

As a source of light in some cases a Nernst lamp was used, generally however an arc lamp.

3. Measurements of the electric double refraction of a cloud of ammonium chloride.

By means of the arrangement described in the preceding paragraph, the phenomena could be investigated with the naked eye qualitatively only. Therefore a camera or a telescope with an ocular-micrometer were used for the measurements. Both were inserted behind the analyzer (see fig. 1).

In order that the place of the black band could be determined, two horizontal wires were stretched on the bead, one horizontally and one vertically. Along the latter the distances

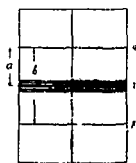

Fig. 4.

could be measured. The image, formed by the lens of the camera or the objective of the telescope, is represented by fig. 4. $\frac{a}{b}$ determines the place of the band.

If now in the path of the light a double refracting substance is inserted with its principal directions

parallel to those of the bead, this ratio becomes $\frac{a_1}{b}$. From the theory

of the bead it now follows, that $\frac{a_1 - a}{b}$ is proportional to the difference in index of refraction of the ordinary and the extra-ordinary beam ($n_o - n_e$). In the case of the photographic method the values a and b were measured on the plates. In the observations by means of the telescope the ocular micrometer with a scale division of five per mm. enabled to read the places directly, from which thus the displacements which were proportional to $(n_o - n_e)$ could again be derived easily.

A difficulty of the measurements was the change the same cloud undergoes in the course of time. These changes are of different nature: 1. the particles, by which the nebulum is formed, gra-

dually become larger; 2. constantly particles disappear; 3. a certain number of them is charged and by a constant electric field these are conducted to one of the condenser plates; 4. the cloud of ammonium chloride especially undergoes still a change which becomes obvious by the change of sign of the double refraction from positive to negative; perhaps this is connected with a change in form or the change in dimensions, mentioned sub 1, of the small crystals. In my dissertation I will show in what way I tried to overcome these disturbing influences.

4. *Results of the measurements.* I first measured the double refraction of the α -modification and that in an alternating field. The condenser vessel used for this and also for all the following experiments of this paragraph had plates on the inside; it had the following dimensions: length 44,5, height 10 cm and inner width 9,5 mm, while to the middle of the vertical sides strokes of tinfoil of 40×4 cm. were applied. The observations were made photographically.

With one plate 4 observations were made:

one without field and then successively for the tensions V_1 , V_2 and V_3 . In the ordinary way this plate was developed and treated further. Afterwards the distances were measured on it. Then the values $\frac{a}{b}$, $\frac{a_1}{b}$, $\frac{a_2}{b}$ and $\frac{a_3}{b}$ are known for the four observations and therefore also the ratios $\frac{a_1-a}{b}$ etc. which are proportional with $n_a - n_b$ of the cloud for fields of V_1 etc.

In order that the cloud may not be changed during the four measurements, $\frac{a_1-a}{b}$ must be equal to $\frac{a_3-a}{b}$. In some cases this difference was rather small, as is shown by this table.

$\frac{a_1-a}{b}$	$\frac{a_3-a}{b}$
0.106	0.104
0.050	0.056
0.077	0.078
0.077	0.085

But even in cases, in which the difference is greater, such a plate has still some value. For if the obtained results are represented graphically, the tensions being taken as abscissae and the values $\frac{a_1-a}{b}$ etc. as ordinates, we find one point for V_2 and two for V_1 .

The curve must therefore pass through 1 the origin, 2 through the point for V_2 , 3 between the points for V_1 . If now the values $\frac{a_1-a}{b}$ and $\frac{a_2-a}{b}$ are very different from each other, there is a rather great distance between the two points found for V_1 . But at any rate we know that the curve must pass between those two points.

In order to determine other points I took new clouds, which I investigated in the fields V_3 , V_2 , V_1 , etc. The second field was always equal to that used with the first plate. By measuring the distances on the plates, we now obtained the ratios $\frac{a_1'-a}{b}$, $\frac{a_2'-a}{b}$,

$\frac{a_3'-a}{b}$ or quantities proportional with these. So we may also make

$\frac{a_3'-a}{b} = \frac{a_2'-a}{b}$, if only at the same time the other forms are changed

in the same ratio. In this way we might obtain a new point for the curve, at least if these considerations are right. In order to know this I investigated *two or more clouds* in the *same* fields, successively V_1 , V_2 , V_1 to see, whether the ratio of the double refraction in the fields V_1 and V_2 was the same.

Some of these ratios for equal fields are given here.

$\frac{a_1-a}{b} ; \frac{a_2-a}{b}$	Tensions
1.13; 1.19; 1.14	$V_2 = 510$ volt $V_1 = 925-1050$ "
1.54; 1.44	$V_2 = 1000$ volt $V_1 = 2500$ "
1.36; 1.30	$V_2 = 510$ volt $V_1 = 1900-1970$ "

From the rather small differences I am inclined to conclude, that the results with different clouds may be combined to one single curve.

In the following table the results obtained with different tensions have been put together.

Tensions	$\frac{a_2 - a_1}{b}$	$\frac{a_1 - a_0}{b}$
$V_2 = 1000$ volt $V_1 = 3500$ "	50	71-80
$V_2 = 1050$ volt $V_1 = 1800$ "	51	63-70
$V_2 = 1000$ volt $V_1 = 2500$ "	50	70-78

Here the tensions have been indicated by the potential differences between the plates in volts. The two following columns give values proportional with $\frac{a_n - a_0}{b}$ and therefore with $n_b - n_y$ of the cloud in the corresponding electric fields; for a tension difference of 1000 volts has been taken the value ± 50 .

Representing this graphically we obtain this curve, where the

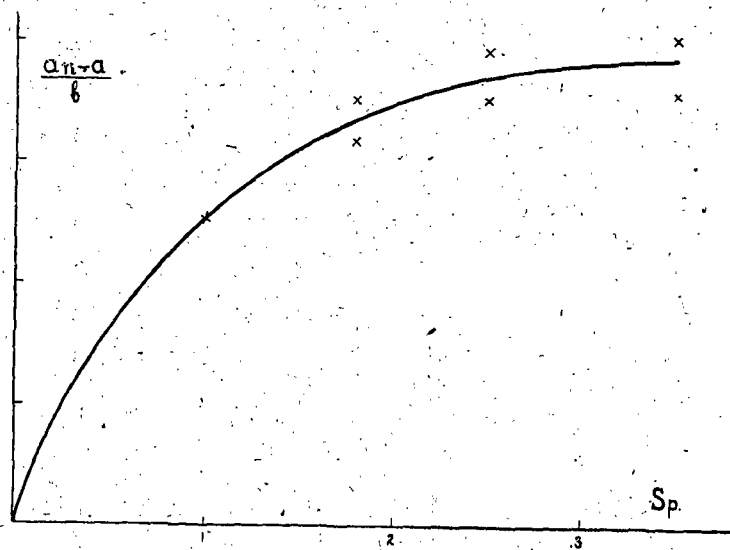

Fig. 5.

tension is measured along the axis of X in kilovolts and the values $\frac{a_n - a_0}{b}$ or quantities proportional with these along the Y axis.

We see that the double refraction approaches asymptotically a maximal value.

The electric double refraction of ammonium chloride is thus proved to be not proportional with the square of the intensity of the field. For if it were so it should have to show a same dependency on the field in an *alternating* field. Since this is not the case however the dependency on the field cannot be derived from the above curve, also by the uncertainty where in this case of the 50 alternations per second the band of the bead will appear; for the band follows the alternations, as has been proved by means of a stroboscopic method.

Therefore an investigation in a *constant* field was required. For this purpose the electric arrangement sketched in fig. 2 was used, with a few changes in the case of weaker fields. The observations were made photographically.

Again one plate was exposed four times with one and the same cloud: first without field and then with the tensions V_1 , V_2 and V_1 .

In the same way as above, the plates were again developed etc. and then the distances were measured. Now too measurements were made for a series of different clouds, the results of which were

Tensions V_1 in volts, while $V_2 = 510$, sometimes = 530 volt	$\frac{a_1 - a}{b}$, while $\frac{a_2 - a}{b}$ has been put = 50	
210	18	19
210	20	23
240	33	35
270	36	49
330	34	36
810	71	74
925	54	59
990	56	63
1050	54	60
1360	57	61
1900	62	68
1970	67	69
2280	54	65
3400	57	68

reduced to each other. The result of the measurements is given above. (See table p. 422).

The results have also been represented graphically in two curves: fig. 6a for the lower, fig. 6b for the higher tensions. In the second diagram the tension is again expressed in kilovolts, in the first in volts.

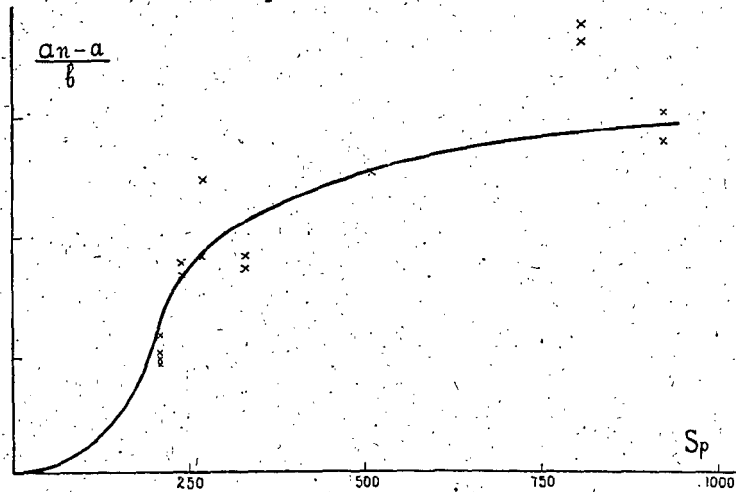

Fig. 6a.

In the region of the lower tensions the curve shows a point of inflexion, so that it is possible — VOIGT regards this as necessary — that by a first approximation the double refraction is proportional with the square of the field.

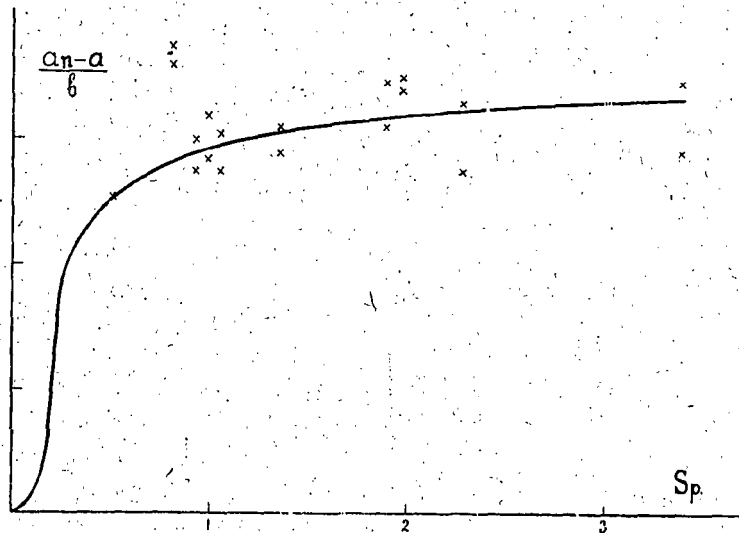

Fig. 6b.

The course of the curve makes it evident that also for a constant field the double refraction approaches asymptotically a maximal value.

Further the double refraction of the β -modification has been measured. This was done by means of a telescope with an ocular-micrometer. This modification was investigated in a constant field only. The researches were made in the following way. A cloud was blown into the condenser vessel. Then the place of the band, the field being not switched on, the zero position, was determined. Then the field was excited, successively the tensions V_1 and V_2 , and the position of the band was read in these cases. As soon after each other as was possible this was repeated twice with the same cloud and finally the zero position was again determined. Here follows a set of observations.

	Zero position	Tension V_1	Tension V_2	Position band for tens. V_1	Position band for tens. V_2	Displacement band		Ratio of the displacements
						for tens. V_1	for tens. V_2	
Observed quantities	$3\frac{1}{4}$	2100	730	$5\frac{1}{4}$	$4\frac{1}{4}$	2	1	1.9
		2100	720	5	$4\frac{1}{4}$	$1\frac{3}{4}$	1	1.7
		2150	720	$4\frac{3}{4}$	4	$1\frac{1}{2}$	$\frac{3}{4}$	1.6
	$3\frac{1}{4}$	2150	720	$4\frac{3}{4}$	4	$1\frac{1}{2}$	$\frac{3}{4}$	1.7
Mean values	$3\frac{1}{4}$	2100	725	—	—	—	—	1.7

The last column has been derived from the two preceding ones by combining each time two successive values of one column with the value from the other column that has been observed between. For nearly equal tensions I made for each of a series of clouds such a set of observations. The mean of this series was

V_1	V_2	Ratio
2125	715	1.68

Also for other tensions series of observations were made. The mean values found from them have been arranged in this table.

V_1 in volts	V_2 in volts	Ratio double refraction
1460	640	1.45
2125	720	1.68
2670	700	1.77
3470	625	1.9

Fig. 7 gives the curve (abscissae in kilovolts) which has a similar form as the preceding one.

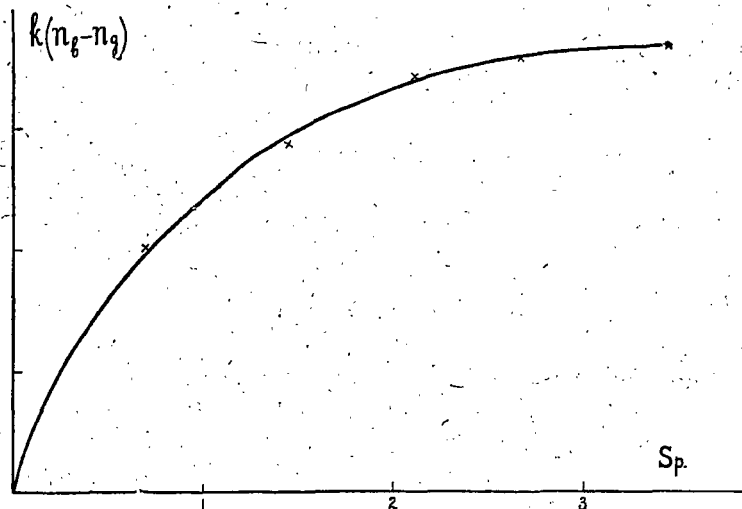

Fig. 7.

It was remarkable, that the double refraction of this modification is sometimes several times greater than that of the α -form. This may be caused by differences in density and difference in specific double refraction.

5. *Dispersion in the electric double refraction.* This occurs by no means always and if it does distinctly for the β -modification. It may be observed by the coloured edges of the black band of the bead, but for a more accurate investigation special decomposition was required. For this purpose an arrangement was used, much similar to that which Prof. ZEEMAN used formerly for his measurements of the Kerr-effect in liquid air¹⁾.

In the telescope of the spectroscope an ocular micrometer had been fixed and by means of this the position of the black band could be read for the different colours. Some results have been given below.

Tension in volts	Zero-position	Place red	Place blue	Displacement red	Displacement blue
5500	$5\frac{1}{2}$	3	4	$2\frac{1}{2}$	$1\frac{1}{2}$
5500	$4\frac{3}{4}$	3	4	$1\frac{3}{4}$	$\frac{3}{4}$

¹⁾ ZEEMAN, these Proceedings XIV, p. 650.

We see, that the dispersion may be very strong and that it is such, that the rays with the greatest index of refraction show the smallest double refraction, which result is in contradiction with all that has been found till now on the electro-optic KERR-effect. Still it may be mentioned, that for the same mean double refraction the cloud showed a greater dispersion when it had stood for some time than when it had just been formed.

With the *α-modification* no definite result was reached. If however dispersion is shown by this too, then the rays of the greatest refractivity will also show the greatest double refraction.

6. *Experiments with other clouds.* Results similar to those found for ammonium chloride were reached with clouds of indigotine and ammonium-bromide and -iodide.

A remark of BLOCH¹⁾ on the properties of a cloud of *indigotine* in a magnetic field induced me to an investigation of this cloud: It was produced by heating the solid substance. For many experiments indigotine pur. cryst. of the "Pharm. Handelsvereinigung" was used. This heating however always caused decomposition, accompanied by formation of clouds²⁾. A dry air current led over the heated substance carried the mixture to a condensator vessel, where it was proved to become double refracting and sometimes slightly dichroistic under the influence of an electric force, while the light was dispersed stronger in a perpendicular direction.

It has not yet been found out which substance it is that shows these properties. For a cloud of aniline, one of the products of decomposition, not any electro-optic effect could be detected.

Ammonium-bromide and -iodide showed just the same properties in the electric field as ammonium-chloride, also in this respect, that one and the same cloud, which at its formation was positively double refracting, after some time had become negative. If this change of sign is connected with the allotropy of those substances, this behaviour might have been expected for ammonium-bromide. For, as to their properties NH_4Cl and NH_4Br are very similar; they are enantiotropic, as has been proved by WALLACE³⁾; for the points of transition SCHEFFER found: for NH_4Cl $184^\circ, 5^4)$ and for NH_4Br about 137° ⁵⁾.

1) BLOCH, Loc. cit.

2) Thus BLOCH speaks of "fumées provenant de la sublimation de l'indigotine".

3) WALLACE, Centralblatt für Mineralogie u.s.w. 1910 S. 33.

4) SCHEFFER, These proceedings, XVIII p 446 and 1498.

5) SCHEFFER, Handelingen 15de Ned. Natuur- en Geneesk. Congres te Amsterdam, pag. 242, Haarlem 1915.

Above these temperatures they crystallize into cubes, below them into the well-known skeleton form. If they are formed at ordinary temperature and undergo later a transformation, there are first formed cubes for them both (the β -modification, unstable at ordinary temperature). Later on a transformation into needles occurs (the α - or stable modification). Ammonium-iodide shows other properties; at ordinary temperature it crystallizes into cubes. SCHEFFER has proved however, that NH_4I is also dimorphous and enantiotropic, but that its point of transition lies near -16° . He had the kindness to tell me this result, which has not yet been published. At ordinary temperature NH_4I will therefore first exist as needles and then as cubes and from what has been said above, we might expect that the change of sign of the double refraction will have the opposite direction for NH_4I as for NH_4Cl and NH_4Br . This not being the case, we may conclude that the allotropy is of no influence in this question. I express still my thanks to Dr. SCHEFFER, who was so kind as to test the purity of the NH_4I .

7. *Some remarks on the explanation of these phenomena.* In my opinion the explanation may not be sought in the direction of the electro-optic KERR-effect. Firstly not because for ammonium-chloride the double refraction approaches a maximal value, while the KERR-effect always shows a quadratic dependence on the field and further because the small density of the cloud (generally less than 0,00005) would oblige us to ascribe to ammonium-chloride a constant of KERR of the order of $10^5 \times$ that of CS_2 , which would be very improbable. I tried to find another explanation by assuming the particles to be directed by the field. Ammoniumchloride being regular in both modifications they should have then a stretched form. Microscopically however such a form could not be detected. Perhaps the particles were too small ($5 \cdot 10^{-5}$ cm. and smaller). Nor was an orientation observed microscopically. Besides the vivid BROWNIAN movement of the particles of the ammonium-chloride many of them were seen — in the case of an alternating field — to get into oscillation, as had formerly already been observed by COTTON and MOUTON¹⁾ and recently again by KRUYT²⁾ in some colloidal solutions. Fall experiments with particles of ammoniumchloride have made it probable however that an electric field causes an orientation

1) COTTON et MOUTON, Les ultramicroscopes. Les objets ultramicroscopiques. Paris 1906, pag. 154 and foll.

2) KRUYT, these Proceedings XVIII, p. 1625.

(PRZIBRAM¹) and researches in the Amsterdam laboratory). This however does not yet explain the double refraction.

A comparison with the behaviour of the "liqueurs mixtes" in an electric, or of the iron of BRAVAIS in a magnetic field is of no value, as in those cases the particles themselves are double refracting or at least are supposed to be so. For ammonium-chloride this is excluded. An explanation may be sought perhaps in the direction of O. WIENER's "double refraction of beads".²).

II. *The influence of the electric field on the intensity of the transmitted and the dispersed light.*

8. *Introduction and method of observation.* Some of these phenomena have already formerly been observed (see I). In this investigation three directions occur: the direction of the incident light (L), that of the electric field (V) and that, in which the observations are made (W). With respect to each other these directions can have different positions. By fixing these by means of the system of coordinates PQR (see fig. 8) we obtain the cases of the next table.

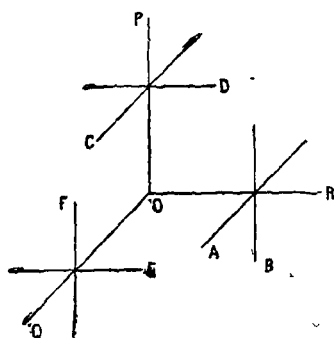

Fig 8.

Number	L	V	W
I	R	Q	P
II	R	Q	Q
III	R	Q	R
IV	R	R	P
V	R	R	R

Moreover we may still distinguish the cases in which the incident light is unpolarized or polarized in one of the "principal directions". Also the state of polarization of the transmitted or of the dispersed light may be investigated.

The observations were made microscopically or with the naked eye. For the first method small condensator vessels were constructed with condensator plates of 15×15 mm at a distance of ± 7 mm; for the other a large condensator was used, the plates of which

¹) PRZIBRAM, Phys. Zs. 11, 630, 1910.

²) O WIENER, Leipz. Ber. 91, 113, 1909, 63, 256, 1910.

had a distance of ± 10.5 mm and which was placed in a box of cardboard, which had been filled with a cloud. All the experiments described in this chapter were made with ammonium-chloride and in an alternating field.

9. *Summary of the observed phenomena.* The following may serve as an interpretation for the tables below, in which the results have been collected; the letters in the second and third columns indicate, that oscillations of the direction denoted by it (see fig. 8) are transmitted. If a letter has been omitted, there is no polarizer or analyzer. The intensity of the field has been given in volts per cm.

It is easily seen that with these three numbers the cases are exhausted. For a polarizer e. g. B cannot give anything new.

The numbers 20 and 21 clearly show the dichroistic character of ammonium-chloride. Formerly Prof. ZEEMAN and the author¹⁾ had

CASE I.

L // R, V // Q, W // P.

Method of observation: microscopically.

Number	Polarizer	Analyzer	Intensity of the field	Phenomena at the switching on of the field.
1	—	—	5400	Strong increase of intensity.
2	—	C	5400	Idem.
3	—	D	5600	Weak incr. of int. Without field cloud blue and not intense.
4	A	—	5600	Strong incr. of int.
5	A	C	5600	Idem.
6	A	D	5600	Without field some particles visible. At the switching on of the field they vanish or become weaker. At the vanishing they reappear. Another time general decrease of intensity under influence of the field.
7	B	—	5600	Moderate but observable incr. of int.
8	B	C	5600	The particles disappear or the int. diminishes. Without field very weak.
9	B	D	5600	Nearly as 7.

¹⁾ ZEEMAN and HOOGENBOOM, Communication II.

CASE II.

L//R, V//Q, W//Q.

Method of observation: directly with the naked eye

Number	Polarizer	Analyzer	Intensity of the field	Phenomena at the switching on of the field.
10	—	—	3900	Decrease of intensity
11	—	E	"	" " "
12	—	F	"	" " "
13	A	—	"	" " "
14	A	E	"	" " "
15	A	F	"	No influence of the field observed (without field very weak)
16	B	—	"	Decrease of intensity.
17	B	F	"	" " "
18	B	E	"	The dispersed light, hardly existing without, seems to vanish quite under influence of the field.

CASE III.

L//R, V//Q, W//R.

Method of observation as II.

Number	Polarizer	Analyzer	Intensity of the field	Phenomena at the switching on of the field.
19	—	—	3800	Decrease of intensity.
20	—	A	"	" " "
21	—	B	"	But " less than for 20.

already concluded from the sense of the "rotation of the plane of polarization", that the oscillations parallel to the electric force are absorbed stronger than those perpendicular to it.

of both phenomena in ammonium-chloride may not be considered however as a statement of these results. For VOIGT¹⁾ finds the connexion

$$\frac{n_1 \kappa_1 - n \kappa}{n_2 \kappa_2 - n \kappa} = -2,$$

where $n \kappa$ is the absorption coefficient outside the field, $n_1 \kappa_1$ and $n_2 \kappa_2$ the absorption coefficients for the ordinary and the extraordinary rays. For ammonium-chloride it has been found here however, that the vibrations along both of the principal directions are absorbed stronger, so that the above fraction is *positive*.

A plausible representation of these phenomena may be obtained however by the assumption of an orientation of the somewhat elongated particles of the ammonium-chloride.

The phenomena of Case I (see 9) are analogous to phenomena of this kind: fine lines on glass or corrosion figures on crystals are seen clearly, when the length direction of the lines or figures is perpendicular to the plane through the incident ray and the line of observation²⁾. In Case II the eye has the most disadvantageous position to receive light of the orientated particles. In Case IV the incident light has a disadvantageous direction for the deflexion. Case V is easily derived from IV. The dispersion only cannot be explained by the orientation. For in the case of a slit-width below a wavelength we should expect just the opposite from what has been observed.³⁾

Finally I wish to express my indebtedness to Prof. ZREMAN for his encouragement and powerful assistance in this research.

Amsterdam, June 1916.

Chemistry. — “*The Interpretation of the Röntgenograms and Röntgenspectra of Crystals*”. By PROF. A. SMITS and DR. F. E. C. SCHEFFER. (Communicated by Prof. J. D. VAN DER WAAALS).

(Communicated in the Meeting of June 24, 1916.)

1. LAUE'S researches³⁾ and those by W. H. and W. L. BRAGG⁴⁾ about the diffraction of Röntgenrays by crystals have given rise to a view about the arrangement of the atoms in the solid substance, which, though sufficiently in agreement with the *physical properties* of the substance, cannot be reconciled with our *chemical ideas*.

¹⁾ Loc. cit. p. 58s.

²⁾ Compare CORTON et MOUTON, Les ultramicroscopes, les objets ultramicroscopiques. Paris 1906, p. 167.

³⁾ Sitzungsber. d. Bayer. Akad. d. Wiss., Juni 1912.

⁴⁾ Proc. Cambridge Phil. Soc. 17 (1912) 1, 45.

The quintessence of this new view is this, that the atoms of a solid substance occupy in a definite way the places of points of a lattice, in which arrangement the molecules no longer occur as separate particles, so that the idea of a molecule would undergo a fundamental modification for the solid substance, for it is immediately seen that according to this view every solid phase both in physical and in chemical sense had to be looked upon as one large molecule.

2. It strikes the chemist immediately that as the forces which occur - e. g. between, Na and Cl atoms in the solid phase have certainly to do with the valency, it would follow from the model designed by BRAGG for solid NaCl that Na just as Cl has a valency of six. This fact is so very remarkable for this reason that importance is attached to the fact that the quadri-valency of the carbon atom would follow from the model for diamond.

Also the model given by BRAGG for calcium-carbonate leads to remarkable conclusions. It appears namely from this model that every Ca-atom is surrounded by six oxygen-atoms, and that the distance between the centres of Ca and O is smaller than that between Ca and C. Along the sides of the calcspar rhomboheda there prevails no chemical force, for there is every reason from chemical side to assume in CaCO_3 no binding between Ca and C, but to do so between Ca and O. Led by the distances in the model of BRAGG we might distinguish CO_3 -groups; then, however, it is remarkable that every Ca-atom would always be connected with one O-atom of six CO_3 -groups, whereas we should have expected that every Ca-atom would be bound to two oxygen atoms of the *same* CO_3 -group. These remarks suffice, therefore, to show that this model cannot be reconciled with our idea of valency.

This objection can be thus further elucidated. In the representation given by the BRAGGS model of the solid substance the considerations are perfectly ignored which have led to the *firm conviction* that the atoms in the molecule are bound by forces which are characterized by their localized nature and by their definite number.

Thus BOLTMANN writes ¹⁾: "Wir erklären die Existenz der aus zwei Atomen zusammengesetzten Moleküle durch eine, zwischen den Atomen thatige anziehende Kraft, welche wir die chemische Anziehung nennen. Die Thatsachen der chemischen Valenz oder Wertigkeit machen es wahrscheinlich, dass die chemische Anziehung keineswegs einfach eine Funktion der Entfernung der Mittelpunkte der Atome ist, dass sie viel mehr bloss an verhältnissmassig kleine Bezirke auf

¹⁾ Vorlesungen über Gastheorie, I, 177.

der Oberfläche der Atome gebunden ist. *Man kann auch nur unter der letzteren, keineswegs unter der ersteren Annahme ein der Wirklichkeit entsprechendes Bild der Gas-dissociation erhalten.*"¹⁾)

Accordingly BOLTZMANN assumes that the chemical attraction resides in a sensitive region (empfindlicher Bezirk) or bulging out of the atom, which gives rise to the origin of a space called by him critical space (kritischer Raum). When now the centre of the second atom lies in the critical space of the first, and the sensitive regions of the two atoms partially overlap, the two atoms are certainly chemically bound to each other.

As BOLTZMANN showed we are now compelled to assume that the sensible region is found locally and not uniformly round the whole atom, as this latter assumption would lead to absurdity. Accordingly the conclusion at which BOLTZMANN has arrived is this: "In dem jetzt betrachteten Falle, wo der kritische Raum über die ganze Oberfläche der Deckungssphäre gleichmässig verteilt ist, würden sich, sobald die Atome sich überhaupt zu verbinden anfangen, sofort mit Vorliebe Aggregate bilden, die eine grössere Atomzahl enthalten. Es würde daher sogleich etwas Aehnliches, wie bei der Verflüssigung eines Gases eintreten".²⁾)

That the chemical attraction acts locally, is certain, and whether we accept BOLTZMANN's view about the chemical attractive force or the newer view of STARK³⁾, of BOHR⁴⁾, or of J. D. VAN DER WAALS JR.⁵⁾, this is entirely indifferent at the moment, we only wish to state here very clearly *that the chemical attractive force is a local force, acting in points the number of which is determined by the valency.*

That this chemical force governs the atom bindings in the molecule also in the solid state, and the valency must manifest itself in this phase as well as in any other, may be considered as firmly established, so that any representation which leaves out of account these circumstances so exceedingly important from a chemical point of view, must be erroneous.

At last a third objection may be pointed out. The present representation of the solid substance is not able to account for the existence of internal equilibria in the solid phase.

3. It appears therefore, clearly from the foregoing that the cur-

¹⁾ The italics are ours.

²⁾ l. c. p. 215.

³⁾ Prinzipien der Atomdynamik III.

⁴⁾ Phil. Mag. (6) 26, 1, 476. 857 (1913).

⁵⁾ These Proc. XVI p. 1082.

rent representation of the solid substance must undergo a modification, so that the fundamental objections mentioned here, are obviated. How this is possible, we shall consider now.

In the very first place it should be pointed out that the Röntgenogram gives us only the relative situation of the centres of gravity of the atoms, and does not teach us anything about the value of the distances *between* the atoms with respect to the parameter of the lattice.

About this question, which is of so great importance for us, we can get to know something by way of estimate.

In the first place the representation that LINDEMANN¹⁾ formed of the atom movement in the solid substance yields a value for the distance between the atoms, which is negligible with respect to the atom radius; it becomes even so small that the compressibility cannot be taken into account without assuming compressibility of the atoms.

Another indication of the smallness of the distances between the atoms resting on a firmer ground, is furnished by what follows. From the determinations of the critical data follows that for normal substances the critical volume is about 2,4 times the value of the b from VAN DER WAALS SR.'s equation of state.

If b is given the value which holds for the rarefied gaseous state, i.e. four times the volume of the molecules, the real value of the volume will certainly be found too small, as the factor 4 decreases for smaller volumes. The minimum value v_m for the volume of the molecules is, therefore, given by the equation $v_k = 9,6 v_m$, in which v_k represents the critical volume.

For ether the critical density is 0,26 according to YOUNG, and at 0° the density of the liquid is 0,72. Hence the following relation exists between the volume at 0°, v , and the volume of the molecules:

$$v = \frac{0,26}{0,72} 9,6 v_m = 3,5 v_m.$$

It follows from this that in liquid ether at least 2/7 of the volume is filled by the molecules. The temperature of 0° C. being about 0,6 times the critical temperature of ether, the just calculated ratio will always exist between the volume of the liquid and the volume of the molecules at a reduced temperature of 0,6 according to the law of corresponding states.

If the molecules are now considered to be spheres, which are arranged cubically, then the free distance between the spheres in the

¹⁾ Physik. Zeitschr. 11, 609 (1910).

direction of the side of the cube is at most 0,4 times the radius of the molecule.

From J. D. VAN DER WAALS Sr.'s new considerations published in this number of the Proceedings, follows quite in accordance with our calculations that the distance between the molecules of a liquid as ether will be *smaller* at 0° than 0,4 of the radius of the molecule.

It follows, therefore, from this that in a liquid phase there exists only a small difference between the distance of the centres of gravity of the molecule and the diameter of the molecule.

If we now consider that as a rule the solid phase possesses a greater density than the liquid phase, it follows immediately from the above calculation that the said difference will be still somewhat smaller for the solid phase.

Accordingly the distance between the molecules in the solid phase is small.

An important conclusion may be drawn from this for the *solid substance*, which runs: *the distance between the atoms which belong to different molecules, will depart very little from the distance between the atoms in the same molecule, which engenders the possibility that these small differences do not find expression in the Röntgenogram.*

The objections advanced here can be entirely obviated by assuming that there exist molecules also in the solid phase, and that the distance between the atoms in the molecule is of the same value as the distance between the atoms of different molecules.

Considered in this light there is no reason to be astonished that the Röntgenogram does not teach us anything about the existence of molecules in the solid phase.

Still it is possible that on refinement of the method of research or on enlargement of the Röntgen image the spots betray a composite character, and in this case the difference between chemical and physical binding might still find expression. Besides the size of the spots is often not negligible with respect to the distances between the spots, so that variations are certainly possible in the distances.

4. It is clear that when special forces make their appearance, always between one Na and one Cl atom the symmetry of the common salt crystal can change. Now as BRAGG himself observed ¹⁾, the model NaCl given by him is not in harmony with the symmetry. It does not seem improbable to us that the occurrence of the special chemical bindings is just in connection with this lower sym-

¹⁾ Proc. Roy. Soc. A **89**, 468 (1913); Zeitschr. f. anorg. Chem. **90**, 216, 1914.

metry¹⁾. However this may be, it seems to us that a model of the crystal cannot be satisfactory, unless the idea of molecule and the lower symmetry find expression in it.

Also the occurrence of internal equilibria must be revealed by the crystal model, which is impossible with the prevalent conception. If we consider e. g. a mixed crystal of two molecule kinds, one of which is a polymer of the other, it must be possible that definite atoms are alternately bound or not bound to others. Of course it is possible that in the formation of double molecules the distances are little modified, if at all, so that this chemical process is not expressed in the Röntgenogram, but then we should at least come to the conviction that the Röntgenogram does not teach us anything about the chemical forces which interest us most, so that in other words we cannot make out whether two neighbouring atoms are chemically bound or whether they are not.

Thus it is e. g. possible that by means of the Röntgenogram no difference is found between a mixed crystal and a chemical binding, when they possess the same symmetry in solid state, though chemically there exists a very great and exceedingly important difference between them.

We thought it incumbent upon us to make these remarks, because from physical side the problem of the atom arrangement in the solid substance seems to be considered as all but solved, though the given solution is entirely incompatible with the most essential element, viz. with the chemical properties.

5. The chemical requirements, therefore, include that the *valency* is expressed, while there are indications for NaCl and KCl that the symmetry is lower than has been assumed in BRAGG's model.

Accordingly BRAGG's model for these chlorides must be subjected to a considerable modification; every atom lying on an axis of symmetry would have to be multivalent on the assumption of chemical bindings, unless the binding lies on the axis itself. To this is added that the valency would depend on the circumstance whether the atom is situated on a 2, 3, or 4 fold axis, or in the centre.

When designing a new model for NaCl we have further been led by the assumption that the distance between the chemically bound atoms will not be greater than that between not bound atoms, and the chemical force, therefore, never acts in a diagonal direction. Further by the assumption that the chemical binding, undoubtedly, is one of the factors that determine the class of symmetry of the

¹⁾ If NaCl should be holoedrical, then it will hold in each case for KCl.

crystal. We have taken these circumstances into account in the following model. There is no atom in the centre of the figure, because when it were present, it would be an atom of a valency of six. For the reason mentioned above the places have been left vacant on the 2 and 3 fold axes. The four-fold-axis has been perfectly covered with molecules in our model, except in the centre.

Just as in BRAGG's model the planes (111) are alternately exclusively covered with Na resp. Cl-atoms. The planes (100) and (110) all contain both Na and Cl-atoms. In every section there occur vacant places, the number of which will relatively decrease as the crystal gets larger. The condition for interference will, however, get more complicated here than in BRAGG's model, because parallel planes are not perfectly equally covered. Testing by observation is rendered less simple in consequence of this. It is, however, clear that among other things the explanation for the difference between the interference images of NaCl and KCl also perfectly applies to our model.

To construct this model one can start from the inner cube, indicated by fig. 1, the side of which is the double parameter of the lattice. There are only homonymous atoms in the centres of the side planes of this cube; these atoms are chemically bound with the atoms lying in the centres of the planes of the second cube (fig. 2), the side of which is four times the parameter of the lattice. The other net-points of the second cube are all as much as possible covered with atoms. The four atoms that lie nearest about the central atom in each plane, are bound with atoms of the third cube, fig. 3. Each plane of the third cube contains 5 atoms, which are bound with the following one. We can now imagine, that the crystal is built up of two kinds of crystal molecules of the size of fig. 2 or fig. 3 or of still greater dimensions. These crystal molecules are derived of the innercube indicated by fig. 1, with Na resp. Cl atoms in the centres of the side planes.

Anorg. Chem. Lab. of the University.

Amsterdam, July 1916.

A. SMITS and F. E. C. SCHEFFER: "The Interpretation of the Röntgenograms and Röntgenspectra of Crystals".

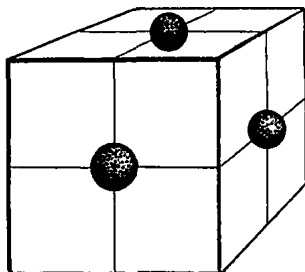

Fig. 1.

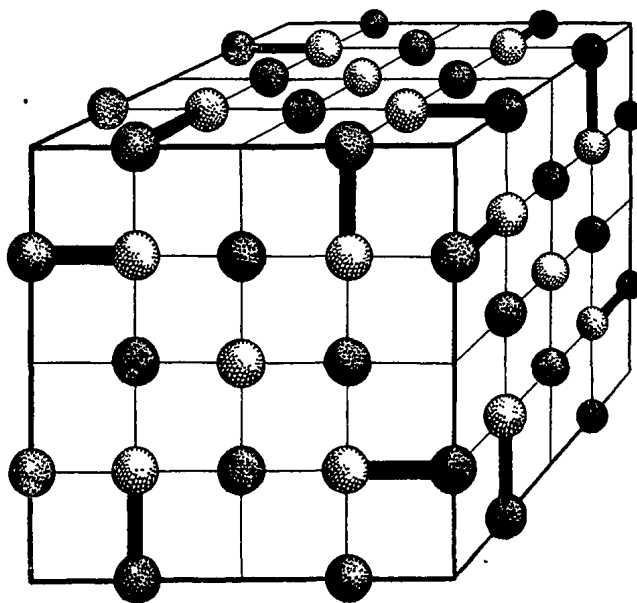

Fig 2.

Proceedings Royal Acad. Amsterdam, Vol. XIX.

A. SMITS and F. E. C. SCHEFFER: "The Interpretation of the Röntgenograms and Röntgenspectra of Crystals".

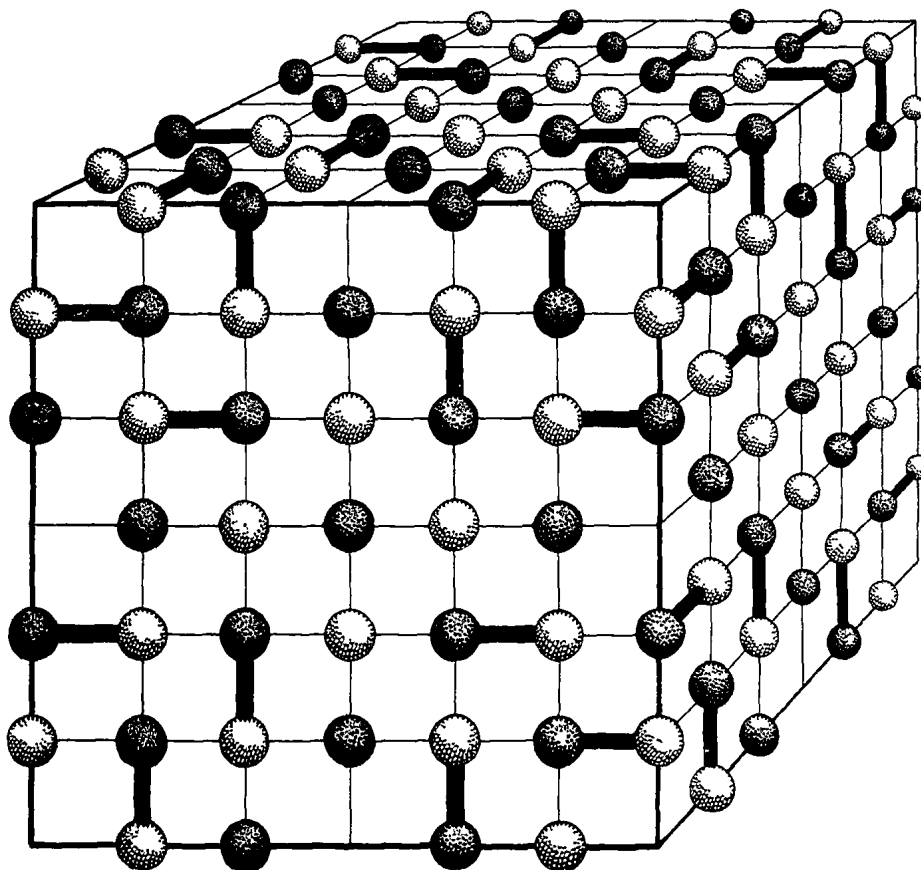

Fig 3.

Proceedings Royal Acad. Amsterdam, Vol. XIX.

Chemistry. — “*The equilibrium solid-liquid-gas in binary systems which present mixed crystals*”. (Third communication). By Prof. H. R. KRUYT and Dr. W. D. HELDERMAN. (Communicated by Prof. ERNST COHEN).

(Communicated in the meeting of June 24, 1916).

In two previous communications one of us¹⁾ has discussed the three-phase equilibrium solid-liquid-gas for a binary system when a complete miscibility is possible in all phases; in connexion therewith the system *p*-dichlorobenzene — *p* dibromobenzene has then been investigated. These investigations led to the result that the three-phase line in such a system has usually a different course from that drawn previously²⁾. The general shape proved to be such that on that line a maximum pressure occurs. In Fig. 1 has been drawn

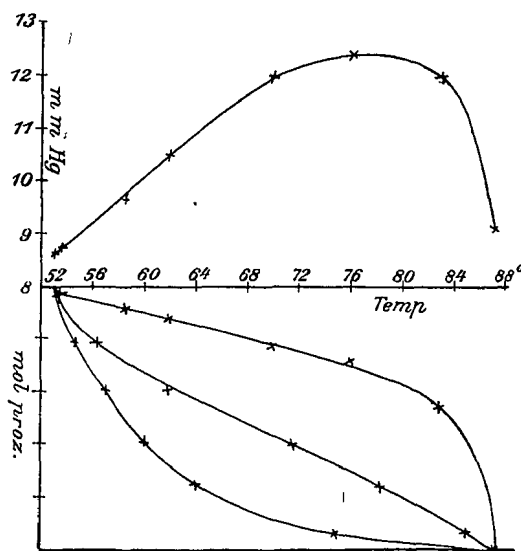

Fig. 1.

a combined PT and Tx projection for the just mentioned system whereas in Fig. 2 the spacial figure is indicated on P, T, x coordinates for this type.

It will be superfluous to describe this figure in detail. Its meaning is plain to any one familiar with the normal figure from BAKHUIS ROOZEBOOM's *Heterogene Gleichgewichte*³⁾.

It is distinguished from the figure mentioned above⁴⁾ by the

¹⁾ H. R. KRUYT, Proc. ^{12, 537-545} ~~18, 542~~ (1909) and ^{13, 206-210} ~~19, 32~~ (1910).

²⁾ H. W. BAKHUIS ROOZEBOOM, Archives Neerlandaises [2] 5, 360 (1900).

³⁾ 2^e Heft pg. 105 (Braunschweig 1904).

⁴⁾ loc cit. previous pg note 2. The figure is also reproduced by H. R. KRUYT, Zeitschr. f. physik. Chem. 79, 657 (1912), Fig. 1.

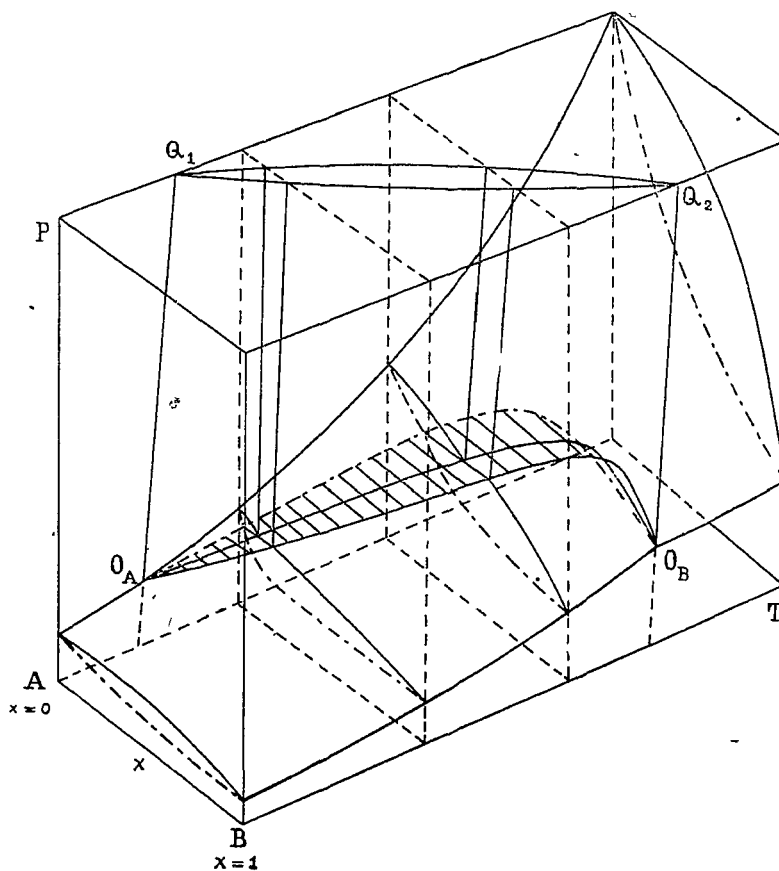

Fig. 2.

peculiarly inflected form of the three-phase region. This has been rendered easily recognisable in Fig. 2 by the additional lines that connect the coexisting phases at each temperature. For further elucidation the lines indicating vapour compositions are shown by --- lines, Px sections are drawn at some temperatures and the Tx melting line has been placed in the upper plane of the figure for the pressure applying to that plane.

2. The result of the previous investigation showing that this figure really represents the normal figure for a system with a continuous series of mixed crystal without a minimum or maximum, makes us expect a peculiar configuration for the system Bromine-Iodine¹⁾ wherein probably a compound IBr occurs; this compound must, however, be credited with the property of being continuously miscible in the solid phase with its products of dissociation, the

¹⁾ P. C. E. MEERUM TERVOGT, Dissertation Amsterdam 1904, *Zetschr. f. anorg. Chem.*, **47**, 203 (1905).

Br and the I. For the melting diagram has a form which is twice that of a system as discussed in the preceding paragraph (see the lower half of Fig. 4) so that both the combinations Br—IBr and IBr—I are comparable therewith. We may thus expect that this system is described by a spacial figure which is a doubling of our Fig. 2.

Here, however, it must be borne in mind that the doubling is not a perfect one because the mixture of 50 atom percent Br and 50 I does not melt sharply, but has a melting range of 1° ; in the melting diagram only narrowing takes place at about the concentration $x = 0.50$. The same applies to the equilibrium L—G. Hence, as no discontinuity occurs at that concentration the two semispacial figures will pass continuously into each other.

Each of the semidiagrams will have to exhibit, in regard to the three-phase tension GLS, a maximum; between those two maxima a minimum must, therefore, be expected.

3. An experimental investigation as to the three-phase pressure GLS in the system Br—I has been started by one of us some years ago; owing to particular circumstances it was postponed but has now been resumed in a somewhat different manner.¹⁾

The purification of the materials used took place in the same manner as with MEERUM TERWOGT. Pure Bromine from KAHLBAUM was first shaken for a few hours with water and then a KBr solution and ZnO were added. This mixture was distilled, the bromine layer distilled again and collected over P_2O_5 . After remaining over night it was distilled off, it passed over entirely at $58^\circ.3$ (corrected) at 751.6 m.m. pressure; nevertheless the first and the last portions of the distillate were not used. The thus made preparation had a sharp melting point at $-7^\circ.4$. The purification of the Iodine took place by subliming *Iodium resublimatum* with addition of KI and then drying over H_2SO_4 .

The *modus operandi* is represented in Fig. 3. In flask A' was contained the mixture of Br and J. BC is a tensimeter containing strong sulphuric acid. The further arrangement E to M serves to compensate the vapour tension of the halogens as much as possible

¹⁾ The investigation in 1912 took place with JACKSON'S glass manometer. There has only been made one preliminary measurement with the mixture of the composition 1Br at $40^\circ.6$. A three-phase pressure of 47.6 mm. of mercury was found. Now a pressure of 48.2 mm. has been found in two independent determinations at $40^\circ.4$. As the three phase tension between 40.4° and 40.6° is indeed falling (see 4 and fig. 4) the agreement is very satisfactory.

with pressure of admitted air so that the sulphuric acid manometer shows but a slight difference in pressure. The compensation pressure is read off on the closed mercury manometer L which is furnished with a plate glass scale thus rendering possible a reading to 0.1 m.m. E is a long india-rubber tube rendering it possible to place the tensimeter in a vertical position inside or outside the thermostat T.

An experiment was carried out as follows: Through the at first open tube D measured portions of Br and I were successively introduced with a long funnel into A; the quantities introduced were determined by weighing the tensimeter. A capillary tube was then sealed to D, and the little flask A was heated until the mixture was wholly fused or nearly so. Then the bulb of the thermometer was slowly cooled to -79° (in the Dewar glass N) and the tensimeter placed horizontally thus causing the sulphuric acid to run into the bulbs C. Halogen vapour was drawn out with a water air-pump and then the capillary tube D connected with P. Q is a long lime tube for the protection of the oil-pump R. The whole apparatus was now carefully evacuated, the capillary was fused off at D and the tensimeter, after a gradual warming, introduced into the thermostat T. In the mean time so much air was admitted into the right half of the apparatus that the sulphuric acid manometer showed but a slight difference in pressure. This was done by means of a three-way cock G. In the tube H was contained air which can be replenished by opening the pinchcock K; a considerable narrowing at I facilitated the regulating. Moreover some modifications in the compensation pressure could be introduced by the displacement of mercury in the gasburettes combination MM. The whole apparatus reminds somewhat of the one employed by MEERUM TERWOGT¹⁾. The measurement of the pressure is here, however, capable of greater accuracy, the pressure compensation is easier whilst the complication near A (a loosely placed in vessel for the reaction mixture) has been omitted as it proved to be superfluous; not once has a tensimeter been broken there.

Reading off the sulphuric acid tensimeter was possible through the pane of glass O of the thermostat.

The density of the acid employed was determined with the sp. gr. bottle at one temperature only; at the other temperatures the table of DOMKE²⁾ was consulted. The thermostat was furnished with a toluene-regulator, a normal thermometer divided to $0^{\circ}.1$ (read off with a magnifying glass) and a constant level arrangement. We

¹⁾ Diss. pag. 37; l. c. pag. 221.

²⁾ Z. f. anorg. Chem. **53**, 125 (1905).

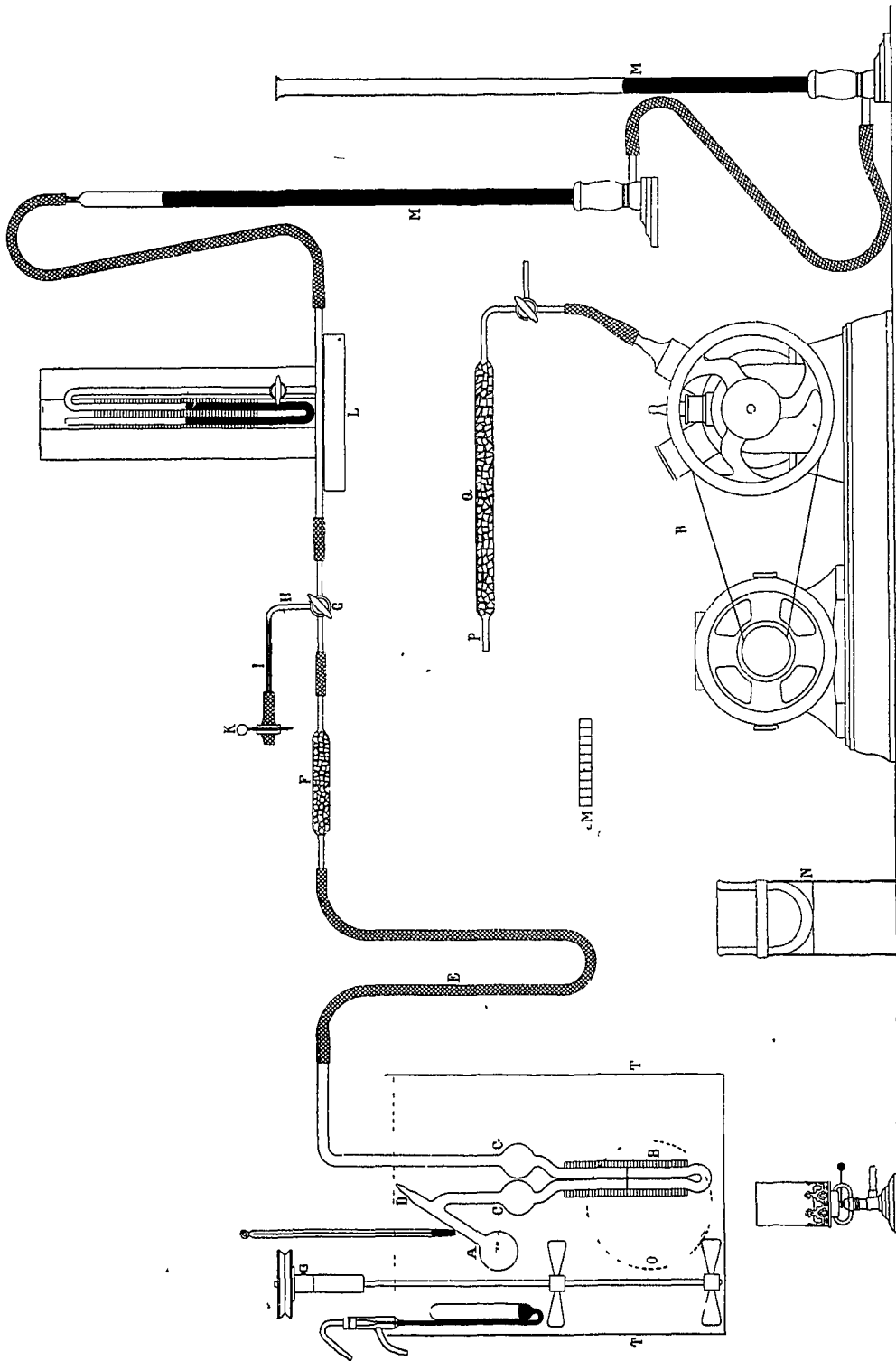

Fig. 3.

chose the experimental temperature in such a manner that we could expect according to TERWOGT'S diagram a partly fused mixture but always satisfied ourselves that this condition in A really existed, which is possible when the apparatus topples over. The experiments were all continued until a perfectly constant end value was attained (usually 24 hours).

4. In the subjoined table are mentioned the results of the experiments. In Fig. 4 they are found indicated graphically combined with the well-known Tx-diagram. The additional triple point tensions are taken from the research of RAMSAY and YOUNG.¹⁾

TABLE.
Three-phase tension in the system Br—I.

Experim. number	Gram Bromine	Gram Iodine	Atom % Iodine	Experiment temperature	Vapour tension in m.m. mercury
11	18.95	14.49	32.5	19.0	83.0
10	16.20	14.49	35.9	23.0	85.8
9	16.20	14.49	35.9	25.0	85.0
2	16.15	19.79	43.6	31.0	79.5
6	15.88	22.52	47.1	36.0	64.1
4	16.25	25.90	50.1	40.4	48.2
1	15.33	24.94	50.5	40.4	48.2
5	15.61	26.11	51.4	42.0	45.4
3	15.55	29.82	54.7	44.3	42.7
7	9.88	23.95	60.4	47.9	54.6
8	9.88	23.95	60.4	50.0	56.7
12	0.93	19.90	92.9	100	> 200

Experiment 12 was executed in the thermostat with boiling water. The three-phase tension was so high that it surpassed the measuring capacity of the manometer.

The results are quite in harmony with the expectations developed in § 2. A plain maximum at 23° and a sharp maximum at 44° have been determined whilst experiment 12 proves the existence of a second maximum.

¹⁾ Journ. chem. Soc. 49, 453 (1886). According to a research of STELZNER and NIEDERSCHULTE Verh. phys. Ges. 7, 159 (1905), the triple point of I would appear to lie a few m.m. higher.

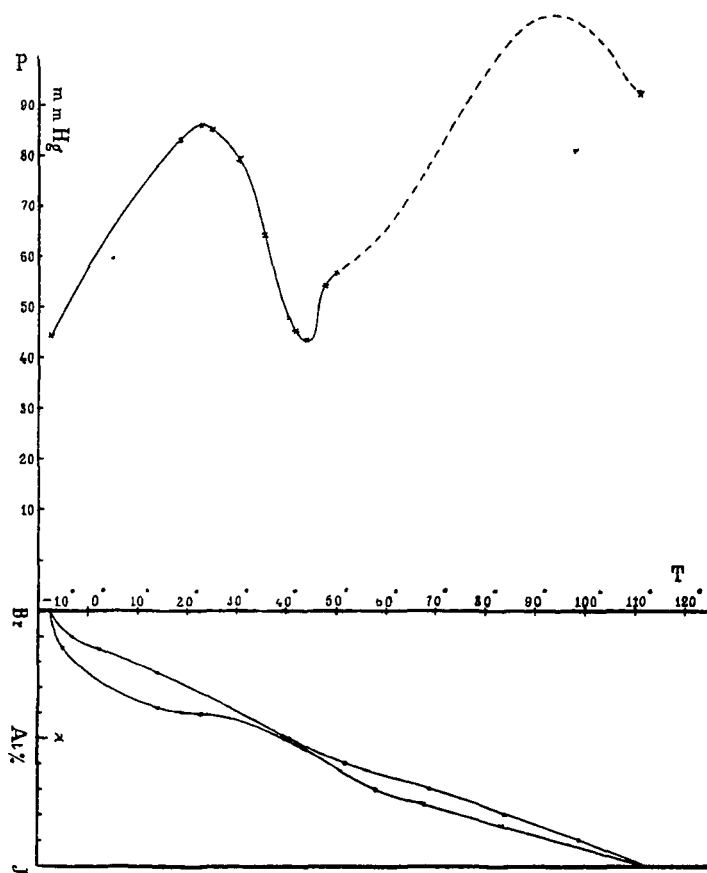

Fig.-4.

We notice that the minimum does not quite lie at the melting temperature of the compound IBr but is removed about 4° to the side of the component with the lower vapour tension.

5. We have sketched in Fig. 5 the spacial figure of a system of the type discussed in this paper. The figures 4 and 5 thus express characteristically that the formation of the compound IBr causes two maxima and an intermediate minimum on the three-phase line whereas in default of that compound only one maximum would occur (Fig. 2). Hence, in the form of the three-phase line we possess a new means of finding a compound in a series of mixed crystals. For we must think that a narrowing in the melting line can only be stated when the interval between liquid and solid branches is large enough to be determined experimentally with sufficient accuracy. This new criterion is all the more welcome because another means cannot be applied to this kind of system. We mean the determination

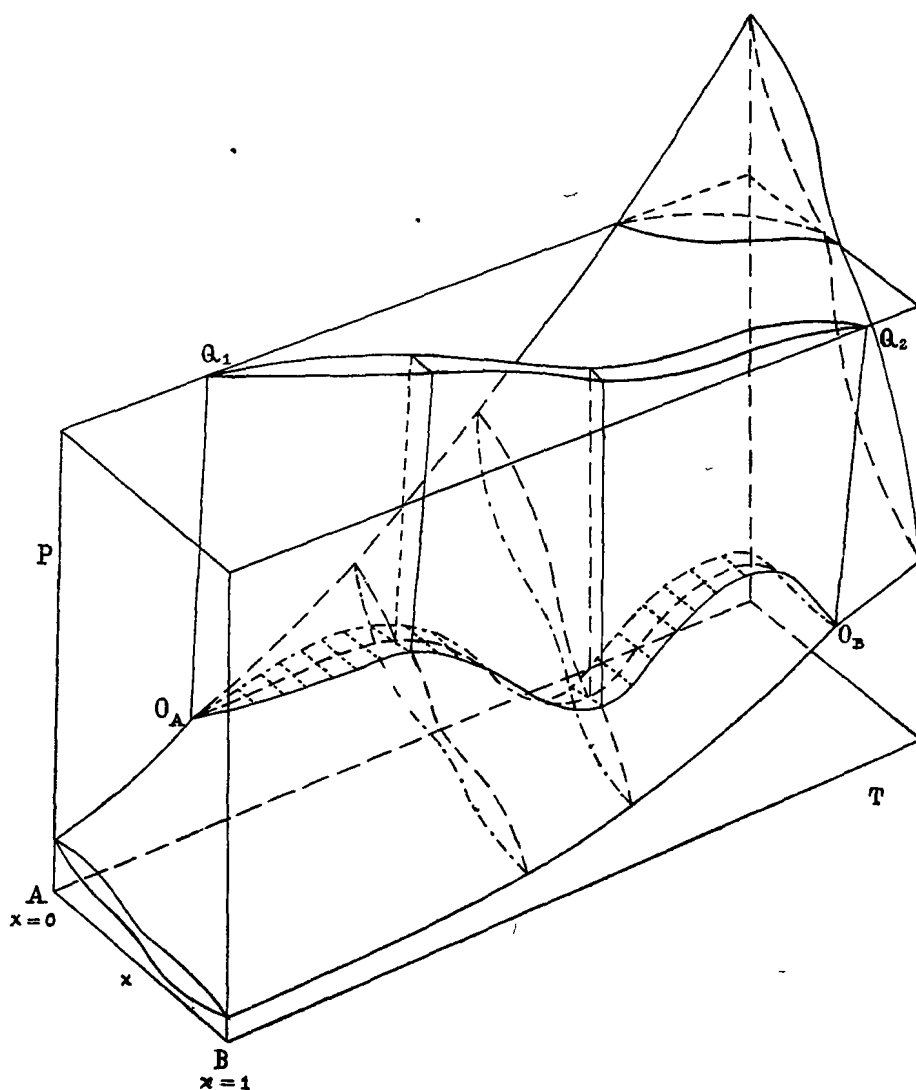

Fig. 5.

of the electric conductivity power, the temperature coefficient thereof, the flow-pressure, the hardness etc., a method which, for instance, has led to such excellent results in the system Mg-Cd¹⁾; in that system the criterion of the three-phase tension is again unsuitable owing to the small value of vapour tension in that system.

The investigation of the three-phase tension in mixed crystal systems can therefore open new points of view in systems where up to the present one has concluded to the absence of compounds and may perhaps lead in other cases to a decision. One might think here of the difference, in the case of optical antipodes, between pseudo-

¹⁾ Compare URASOFF. Z. f. anorg. Chem. **73**, 31 (1912).

racemic mixed crystals and racemic compounds. If, for instance, in the system of *d* and *l*-carvoxim the three-phase tension is to be determined, one might think, in connection with the above that we can perhaps come to a conclusion as to the much discussed question whether we are dealing here merely with a maximum in a series of mixed crystal or whether we are dealing with a racemic compound giving continuous mixed crystal series with the antipodes. Meanwhile it is shown on closer investigation that the resolving of the problem cannot be expected in that manner.

6. The peculiar form of the three-phase line and the correlated spacial figure give rise to different theoretical considerations. We hope to soon revert to the matter, also in connexion with the discussion in the previous paragraph.

Utrecht, June 1916.

VAN 'T HOFF-Laboratory.

Physics — “*The field of n moving centres in EINSTEIN'S theory of gravitation*”. By J. DROSTE. (Communicated by Prof. H. A. LORENTZ).

(Communicated in the meeting of June 24, 1916).

1. If in one or other field of gravitation there is placed a particle, i.e. a body so small that, though influenced by the field, it does not itself exercise any influence on the field, it will move in such a way that the first variation of the time integral of

$$L = \left(\sum_{i,j} g_{ij} \dot{x}_i \dot{x}_j \right)^{\frac{1}{2}}$$

calculated after some definite way, is zero. Here $x_4 = t$, and so $\dot{x}_4 = 1$. If $\dot{x}_1, \dot{x}_2, \dot{x}_3$ are small with respect to unity (i.e. nearly the velocity of light), g_{44} will be much larger than say $g_{11}\dot{x}_1^2$. We will call a term one of the first order if, after division by the square of a component of a velocity, it gets a moderate value. Now, as in NEWTON'S theory, which accounts for the phenomena very closely, it follows from the equation of energy that a term, multiplied by the constant of gravity κ , is of the same order as the square of a velocity, we will call also such a term one of the first order and consequently a term, which contains κ^2 , of the second order.

Our purpose is the calculation of L up to the terms of the second order inclusive. If there is no body whatever that can produce a field, we shall have

$$g_{11} = g_{22} = g_{33} = -1 \quad , \quad g_{44} = 1 \quad , \quad g_{ij} = 0 \quad (i \neq j).$$

In g_{ij} ($i \neq 4, j \neq 4$) we now have to go only up to the terms of the first order inclusive, in g_{14}, g_{24}, g_{34} up to the terms of order $1\frac{1}{2}$, in g_{44} up to the terms of order 2. As the quantities g_{14}, g_{24}, g_{34} may be considered to arise from the motions of the bodies that produce the field (viz. by the changes that arise consequently in the field of the first order), we will suppose that g_{14}, g_{24}, g_{34} only contain terms of order $1\frac{1}{2}$ (or higher). We consequently put

$$g_{ij} = a_{ij} + \kappa \beta_{ij} \quad (i \neq 4, j \neq 4), \quad g_{i4} = a_{i4} + \kappa^{3/2} \sigma_{i4} \quad (i \neq 4), \quad g_{44} = a_{44} + \kappa \beta_{44} + \kappa^2 \gamma_{44}$$

$$g^{ij} = a^{ij} + \kappa \beta^{ij}, \quad g^{i4} = a^{i4} + \kappa^{3/2} \sigma^{i4}, \quad g^{44} = a^{44} + \kappa \beta^{44} + \kappa^2 \gamma^{44}$$

For all values of i and j the quantities a_{ij} and a^{ij} represent the values of g_{ij} and g^{ij} in the case of absence of any gravitating body.

As to the differential coefficients of these quantities a differentiation with respect to x_1, x_2, x_3 will not change their order, a differentiation with respect to x_4 , however, will raise their order by $\frac{1}{2}$.

In the equations of the field

$$2 G_{ij} = -2\kappa T_{ij} + \kappa g_{ij} T \dots \dots \dots (1)$$

the left hand member is

$$2 G_{ij} = 2 \sum_l \left(\frac{\partial}{\partial x_j} \left\{ \begin{matrix} i l \\ l \end{matrix} \right\} - \frac{\partial}{\partial x_l} \left\{ \begin{matrix} i j \\ l \end{matrix} \right\} \right) + 2 \sum_{lm} \left(\left\{ \begin{matrix} i l \\ m \end{matrix} \right\} \left\{ \begin{matrix} j m \\ l \end{matrix} \right\} - \left\{ \begin{matrix} i j \\ m \end{matrix} \right\} \left\{ \begin{matrix} m l \\ l \end{matrix} \right\} \right),$$

where

$$\left\{ \begin{matrix} i j \\ l \end{matrix} \right\} = \sum_n g^{ln} \left[\begin{matrix} i j \\ n \end{matrix} \right], \quad \left[\begin{matrix} i j \\ n \end{matrix} \right] = \frac{1}{2} \left(\frac{\partial g_{im}}{\partial x_j} + \frac{\partial g_{jn}}{\partial x_i} - \frac{\partial g_{ij}}{\partial x_n} \right).$$

Putting

$$\left[\begin{matrix} i j \\ n \end{matrix} \right]_{\beta} = \frac{1}{2} \left(\frac{\partial \beta_{im}}{\partial x_j} + \frac{\partial \beta_{jn}}{\partial x_i} - \frac{\partial \beta_{ij}}{\partial x_n} \right)$$

and giving to

$$\left[\begin{matrix} i j \\ n \end{matrix} \right]_{\sigma} \text{ and } \left[\begin{matrix} i j \\ n \end{matrix} \right]_{\gamma}$$

a corresponding meaning (putting $g_{ij} = a_{ij} + \kappa \beta_{ij} + \kappa^{3/2} \sigma_{ij} + \kappa^2 \gamma_{ij}$ for all values of i and j , so that many of the β_{ij}, σ_{ij} and γ_{ij} become zero), we get

$$\left\{ \begin{matrix} i j \\ l \end{matrix} \right\} = \sum_n (a^{ln} + \kappa \beta^{ln} + \kappa^{3/2} \sigma^{ln} + \kappa^2 \gamma^{ln}) \left(\kappa \left[\begin{matrix} i j \\ n \end{matrix} \right]_{\beta} + \kappa^{3/2} \left[\begin{matrix} i j \\ n \end{matrix} \right]_{\sigma} + \kappa^2 \left[\begin{matrix} i j \\ n \end{matrix} \right]_{\gamma} \right),$$

and so, omitting terms of higher than the second order, we obtain

$$\left\{ \begin{matrix} i j \\ l \end{matrix} \right\} = \kappa a^{ll} \left[\begin{matrix} i j \\ l \end{matrix} \right]_{\beta} + \kappa^{3/2} a^{ll} \left[\begin{matrix} i j \\ l \end{matrix} \right]_{\sigma} + \kappa^2 \sum_n \beta^{ln} \left[\begin{matrix} i j \\ n \end{matrix} \right]_{\beta} + \kappa^2 a^{ll} \left[\begin{matrix} i j \\ l \end{matrix} \right]_{\gamma} \dots (2)$$

2. We now proceed to the calculation of the terms of the first

order in (1). The second part of G_{ij} contributes nothing, and in the first part we need only substitute the first term of (2). We so get

$$2\kappa \sum_l \alpha^{ll} \left(\frac{\partial}{\partial x_j} \left[\frac{\partial}{\partial x_l} \right] - \frac{\partial}{\partial x_l} \left[\frac{\partial}{\partial x_j} \right] \right) = \\ = \kappa \sum_l \alpha^{ll} \left(\frac{\partial^2 \beta_{ll}}{\partial x_j \partial x_l} + \frac{\partial^2 \beta_{lj}}{\partial x_l^2} - \frac{\partial^2 \beta_{il}}{\partial x_l \partial x_j} - \frac{\partial^2 \beta_{jl}}{\partial x_l \partial x_i} \right) \dots (3)$$

If we indicate an index, that does not take the value 4, by placing it in parentheses, we can write for this

$$-\kappa \sum_{(l)} \left(\frac{\partial^2 \beta_{ij}}{\partial x_l^2} - \frac{\partial^2 \beta_{il}}{\partial x_l \partial x_j} - \frac{\partial^2 \beta_{jl}}{\partial x_l \partial x_i} \right) + \\ + \kappa \sum \alpha^{ll} \frac{\partial^2 \beta^{ll}}{\partial x_j \partial x_i} + \kappa \left(\frac{\partial^2 \beta_{ij}}{\partial x_4^2} - \frac{\partial^2 \beta_{i4}}{\partial x_4 \partial x_j} - \frac{\partial^2 \beta_{j4}}{\partial x_4 \partial x_i} \right), \dots (4)$$

in which the last term is at least of the second order.

The terms of the first order become

in the case $i \neq 4, j \neq 4$: $-\kappa \sum_{(l)} \left(\frac{\partial^2 \beta_{ij}}{\partial x_l^2} - \frac{\partial^2 \beta_{il}}{\partial x_l \partial x_j} - \frac{\partial^2 \beta_{jl}}{\partial x_l \partial x_i} \right) + \kappa \sum_l \alpha^{ll} \frac{\partial^2 \beta_{ll}}{\partial x_j \partial x_i}$,

in the case $i \neq 4, j = 4$: zero,

in the case $i = j = 4$: $-\kappa \sum_{(l)} \frac{\partial^2 \beta_{44}}{\partial x_l^2} = -\kappa \Delta \beta_{44}$.

We now suppose the quantity T_{44} to be the only of all T_{ij} , which contains a term ϱ of order 0. Then the term of order 0 in T being also ϱ , we obtain

$$\sum_{(l)} \left(\frac{\partial^2 \beta_{ij}}{\partial x_l^2} - \frac{\partial^2 \beta_{il}}{\partial x_l \partial x_j} - \frac{\partial^2 \beta_{jl}}{\partial x_l \partial x_i} \right) - \sum_l \alpha^{ll} \frac{\partial^2 \beta_{ll}}{\partial x_i \partial x_j} = \sigma_{ij} \varrho, (i \neq 4, j \neq 4) \\ \Delta \beta_{44} = \varrho$$

The equations are satisfied by

$$\beta_{ij} = 0 (i \neq j), \beta_{11} = \beta_{22} = \beta_{33} = \beta_{44} = \beta, \dots (5)$$

β being a solution of

$$\Delta \beta = \varrho. \dots (6)$$

This solution, however, is by no means unique. We may e.g. add to it

$$\beta_{ij} = \frac{\partial^2 \varphi}{\partial x_i \partial x_j};$$

where φ is a function of x_1, x_2, x_3 ; we will, however, not do so.

3. Substituting the solution (5) into the expression (4) and omitting the terms of order 2, we obtain

$$\begin{aligned} \sigma_{i,j} \kappa \frac{\partial^2 \beta}{\partial x_i^2} \text{ (in the case } i \neq 4, j \neq 4) &- 2 \kappa \frac{\partial^2 \beta}{\partial x_4 \partial x_i} \text{ (in the case } i \neq 4, j = 4), \\ &- 3 \kappa \frac{\partial^2 \beta}{\partial x_4^2} \text{ (in the case } i = j = 4). \end{aligned}$$

We now substitute the second term of (2) into the first part of $2G_{i,j}$. This yields an expression similar to (4), the difference being only that $\kappa^{1/2}$ and σ occur in it instead of κ and β . We easily find

$$\text{in the case } i \neq 4, j \neq 4: \quad - \kappa^{1/2} \left(\frac{\partial^2 \sigma_{i4}}{\partial x_4 \partial x_j} + \frac{\partial^2 \sigma_{j4}}{\partial x_4 \partial x_i} \right), \quad (\text{order } 2)$$

$$\text{in the case } i \neq 4, j = 4: \quad - \kappa^{1/2} \sum_{(l)} \left(\frac{\partial^2 \sigma_{il}}{\partial x_l \partial x_i} - \frac{\partial^2 \sigma_{l4}}{\partial x_l^2} \right), \quad (\text{order } 1 \frac{1}{2})$$

$$\text{in the case } i = j = 4: \quad 2 \kappa^{1/2} \sum_{(l)} \frac{\partial^2 \sigma_{4l}}{\partial x_4 \partial x_l}. \quad (\text{order } 2)$$

Substituting the fourth term of (5) in the first part of $2G_{i,j}$, we get

$$\begin{aligned} \text{in the case } i \neq 4, j \neq 4: &- \kappa^2 \sum_{(l)} \left(\frac{\partial^2 \gamma_{ij}}{\partial x_l^2} - \frac{\partial^2 \gamma_{il}}{\partial x_l \partial x_j} - \frac{\partial^2 \gamma_{jl}}{\partial x_l \partial x_i} \right) + \\ &+ \kappa^2 \sum_l a_{ll} \frac{\partial^2 \gamma_{ll}}{\partial x_l \partial x_j}, \quad (\text{order } 2) \end{aligned}$$

$$\text{in the case } i \neq 4, j = 4: \quad \text{zero},$$

$$\text{in the case } i = j = 4: \quad - \kappa^2 \Delta \gamma_{44}. \quad (\text{order } 2)$$

We further must substitute the third term of (2) in the first part of $2G_{i,j}$. Now we have $\beta^{ij} = 0$ ($i \neq j$) and $\beta^{11} = \beta^{22} = \beta^{33} = \beta^{44} = -\beta$. So the third term of (2) becomes

$$- \kappa^2 \beta \left[\begin{array}{c} ij \\ l \end{array} \right]_{\beta}$$

and the corresponding part of $2G_{i,j}$ will be

$$\begin{aligned} &- 2 \kappa^2 \sum_l \left\{ \frac{\partial}{\partial x_l} \left(\beta \left[\begin{array}{c} il \\ l \end{array} \right]_{\beta} \right) - \frac{\partial}{\partial x_l} \left(\beta \left[\begin{array}{c} ij \\ l \end{array} \right]_{\beta} \right) \right\} = \\ &= - 4 \kappa^2 \frac{\partial}{\partial x_j} \left(\beta \frac{\partial \beta}{\partial x_i} \right) + \kappa^2 \sum_l \frac{\partial}{\partial x_l} \left(\beta \left[\frac{\partial \beta_{il}}{\partial x_j} + \frac{\partial \beta_{jl}}{\partial x_i} - \frac{\partial \beta_{ij}}{\partial x_l} \right] \right) = \\ &= - 2 \kappa^2 \frac{\partial}{\partial x_j} \left(\beta \frac{\partial \beta}{\partial x_i} \right) - \sigma_{ij} \kappa^2 \sum_{(l)} \frac{\partial}{\partial x_l} \left(\beta \frac{\partial \beta}{\partial x_l} \right), \end{aligned}$$

where the term $-\sigma_{ij} \kappa^2 \left(\beta \frac{\partial \beta}{\partial x_l} \right)$, being of the third order, is omitted.

We so obtain

$$\text{in the case } i \neq 4, j \neq 4: \quad - 2 \kappa^2 \frac{\partial \beta}{\partial x_j} \left(\beta \frac{\partial \beta}{\partial x_i} \right) - \sigma_{ij} \kappa^2 \sum_{(l)} \frac{\partial}{\partial x_l} \left(\beta \frac{\partial \beta}{\partial x_l} \right).$$

$$\text{in the case } i \neq 4, j = 4: \quad \text{zero},$$

$$\text{in the case } i = j = 4: \quad - \kappa^2 \sum_{(l)} \frac{\partial}{\partial x_l} \left(\beta \frac{\partial \beta}{\partial x_l} \right).$$

At last we have to substitute the first term of (2) in the second part of $2G_{ij}$. This yields

$$\begin{aligned} & 2\kappa^2 \sum_{lm} \alpha^{ll} \alpha^{mm} \left(\left[\begin{matrix} i \\ m \end{matrix} \right]_{\beta} \left[\begin{matrix} j \\ l \end{matrix} \right]_{\beta} - \left[\begin{matrix} i \\ m \end{matrix} \right]_{\beta} \left[\begin{matrix} j \\ l \end{matrix} \right]_{\beta} \right) = \\ & = \kappa^2 \sum_{lm} \alpha^{ll} \alpha^{mm} \left\{ \frac{\partial \beta_{im}}{\partial x_l} \frac{\partial \beta_{jl}}{\partial x_m} - \frac{\partial \beta_{im}}{\partial x_l} \frac{\partial \beta_{jm}}{\partial x_l} + \frac{1}{2} \frac{\partial \beta_{lm}}{\partial x_l} \frac{\partial \beta_{lm}}{\partial x_l} - \right. \\ & \left. - \frac{1}{2} \left(\frac{\partial \beta_{im}}{\partial x_j} + \frac{\partial \beta_{jm}}{\partial x_i} - \frac{\partial \beta_{ij}}{\partial x_m} \right) \frac{\partial \beta_{ll}}{\partial x_m} \right\} = \kappa^2 \frac{\partial}{\partial x_l} \frac{\partial \beta}{\partial x_l} + \kappa^2 (\alpha_{ij} + \alpha_{ij}) \sum_{(l)} \left(\frac{\partial \beta}{\partial x_l} \right)^2 \end{aligned}$$

Omitting terms of the first order, we so find for the left hand member of the equations of the field

$$\begin{aligned} \text{in the case } i=j=4: & \quad - \kappa^2 \sum_{(l)} \left(\frac{\partial^2 \gamma_{ij}}{\partial x_l^2} - \frac{\partial^2 \gamma_{il}}{\partial x_l \partial x_j} - \frac{\partial^2 \gamma_{jl}}{\partial x_l \partial x_i} \right) \\ & + \kappa^2 \sum_l \alpha^{ll} \frac{\partial^2 \gamma_{ll}}{\partial x_l \partial x_l} + \alpha_{ij} \kappa \frac{\partial^2 \beta}{\partial x_4^2} - \kappa^{1/2} \left(\frac{\partial^2 \sigma_{i4}}{\partial x_4 \partial x_j} + \frac{\partial^2 \sigma_{j4}}{\partial x_4 \partial x_i} \right) - \\ & - 2\kappa^2 \frac{\partial}{\partial x_j} \left(\beta \frac{\partial \beta}{\partial x_i} \right) - \alpha_{ij} \kappa^2 \sum_{(l)} \left(\beta \frac{\partial \beta}{\partial x_l} \right) + \kappa^2 \frac{\partial \beta}{\partial x_l} \frac{\partial \beta}{\partial x_j} \end{aligned}$$

$$\text{in the case } i=4, j=4: \quad \kappa^{1/2} \sum_{(l)} \left(\frac{\partial^2 \sigma_{4l}}{\partial x_l \partial x_l} - \frac{\partial^2 \sigma_{44}}{\partial x_l^2} \right) - 2\kappa \frac{\partial^2 \beta}{\partial x_l \partial x_l}$$

$$\begin{aligned} \text{in the case } i=j=4: & \quad - \kappa \Delta \gamma_{44} - 3\kappa \frac{\partial^2 \beta}{\partial x_4^2} + 2\kappa^{1/2} \sum_{(l)} \frac{\partial^2 \sigma_{4l}}{\partial x_4 \partial x_l} - \\ & - \kappa^2 \sum_{(l)} \frac{\partial}{\partial x_l} \left(\beta \frac{\partial \beta}{\partial x_l} \right) + 2\kappa^2 \sum_{(l)} \left(\frac{\partial \beta}{\partial x_l} \right)^2 \end{aligned}$$

From these expressions we see that the third must serve for the calculation of γ_{44} , the second for that of σ_{ll} , the first for that of the six quantities γ_{ij} ($i=4, j=4$) after substitution of the values, found for σ_{4l} and γ_{4l} in some terms of it. As we want only the terms in L up to the second order inclusive, the case $i=4, j=4$ may be omitted.

The last expression can be reduced a little further. First we have

$$\sum_{(l)} \frac{\partial}{\partial x_l} \left(\beta \frac{\partial \beta}{\partial x_l} \right) = \Delta \left(\frac{1}{2} \beta^2 \right)$$

and further

$$2 \sum_{(l)} \left(\frac{\partial \beta}{\partial x_l} \right)^2 = \Delta (\beta^2) - 2\beta \Delta \beta = \Delta (\beta^2) - 2Q\beta,$$

so that we obtain

$$- \kappa^2 \Delta (\gamma_{44} - \frac{1}{2} \beta^2) - 2\kappa^2 Q\beta - 3\kappa \frac{\partial^2 \beta}{\partial t^2} + 2\kappa^{3/2} \sum_{(l)} \frac{\partial^2 \sigma_{4l}}{\partial t \partial x_l}.$$

The quantities T in the right hand member of the equations of the field are to be calculated only up to terms of the first order inclusive. Consequently

$$T = (1 - \kappa\beta) T_{44} - \sum_{(l)} T_{ll}.$$

In the case $i = 4, j = 4$ we so obtain

$$\kappa^{1/2} \sum_{(l)} \left(\frac{\partial^2 \sigma_{l4}}{\partial x_l \partial x_l} - \frac{\partial^2 \sigma_{i4}}{\partial x_l^2} \right) = 2 \frac{\partial^2 \beta}{\partial t \partial x_l} - 2 T_{i4} \dots \dots \dots (7)$$

and in the case $i = j = 4$

$$\kappa^2 \Delta (\gamma_{44} - \frac{1}{2} \beta^2) = 3\kappa \frac{\partial^2 \beta}{\partial t^2} + 2\kappa^{3/2} \sum_{(l)} \frac{\partial^2 \sigma_{l4}}{\partial t \partial x_l} - 2\kappa^2 \rho \beta + \kappa (T_{44} - \rho) + \kappa \sum_{(l)} T_{ll} \quad (8)$$

4. We now proceed to the calculation of the quantities T_{ij} . They have to satisfy the equations

$$\sum_{lj} \frac{\partial}{\partial x_j} (\sqrt{-g} g^{lj} T_{il}) = \frac{1}{2} \sum_{lmn} \sqrt{-g} g^{lm} g^{jn} \frac{\partial g_{lj}}{\partial x_i} T_{mn}.$$

Expressing the equality of the terms of the lowest order on each side, we have

$$\left. \begin{aligned} \frac{\partial T_{i4}}{\partial t} - \sum_{(l)} \frac{\partial T_{il}}{\partial x_l} &= \frac{1}{2} \kappa \rho \frac{\partial \beta}{\partial x_i}, \quad (i = 1, 2, 3) \\ \frac{\partial \rho}{\partial t} - \sum_{(l)} \frac{\partial T_{4l}}{\partial x_l} &= 0. \end{aligned} \right\} \dots \dots \dots (9)$$

In order to be able to calculate the quantities T we must make definite suppositions on the elastic properties of the bodies. Suppose them to be perfect liquids and suppose their expansions and compressions to be adiabatic. Then

$$T_i^l = - \delta_i^l p + \{p + \rho (1 + P)\} \frac{ds}{dx_l} \sum g_{im} \frac{dx_m}{ds}$$

(vid. EINSTEIN "Formale Grundlage..." p. 1062). p represents the pressure and

$$P = - \int_{\varphi_0}^{\varphi} p d\varphi,$$

if φ represents the volume (in natural measure) at the pressure p and φ_0 the volume at the pressure φ_0 , both of a quantity whose mass is 1 at the pressure 0; $\rho\varphi = 1$. The tensor T_{ij} becomes now

$$T_{ij} = -pg_{ij} + \{p + \rho(1 + P)\} \sum_{lm} g_{im} g_{jl} \dot{x}_m \dot{x}_l - \sum_{ab} g_{ab} \dot{x}_a \dot{x}_b$$

Expanding the denominator and omitting all terms of higher than the first order, we find from this

$$\left. \begin{aligned} T_{ij} &= \delta_{ij} p + \rho \dot{x}_i \dot{x}_j \quad (i = 4, j = 4), \quad T_{i4} = -\rho \dot{x}_i, \\ T_{44} &= \rho + \rho \sum \dot{x}_l^2 + \kappa \rho \beta + \rho P. \end{aligned} \right\} \dots \dots \dots (10)$$

The last equation shows that ρ is the same quantity as the quantity named so before and occurring in (6) and (8).

Substituting (10) in (7) and (8) and returning to the quantities g_{ij} themselves, we find

$$\sum_{(l)} \left(\frac{\partial g_{l4}}{\partial x_l \partial x_i} - \frac{\partial^2 g_{i4}}{\partial x_l^2} \right) = 2\kappa \frac{\partial^2 \beta}{\partial x_i \partial t} + 2\kappa \rho \dot{x}_i \dots \dots (11)$$

and

$$\Delta(g_{44} - \frac{1}{2} \kappa^2 \beta^2) = \kappa(\rho + 3p + \rho P) - \kappa^2 \rho \beta + 2\kappa \rho \sum_{(l)} \dot{x}_l^2 + 2 \sum_{(l)} \frac{\partial^2 g_{l4}}{\partial x_l \partial x_i} - 3\kappa \frac{\partial^2 \beta}{\partial t^2} \quad (12)$$

5. We now proceed to the solution of (11) and (12). From (6) it follows that

$$\beta = - \int \frac{\rho dS}{4\pi r}, \dots \dots \dots (13)$$

where r means the distance from dS to the point where β is to be calculated. (11) is satisfied by

$$g_{i4} = 2\kappa \int \frac{\rho \dot{x}_i dS}{4\pi r}, \dots \dots \dots (14)$$

from which we get

$$\sum_{(l)} \frac{\partial^2 g_{l4}}{\partial x_l \partial t} = 2\kappa \frac{\partial^2 \beta}{\partial t^2}$$

and consequently (12) becomes

$$\Delta(g_{44} - \frac{1}{2} \kappa^2 \beta^2) = \kappa(\rho + 3p + \rho P) - \kappa^2 \rho \beta + 2\kappa \rho \sum_{(l)} \dot{x}_l^2 + \kappa \frac{\partial^2 \beta}{\partial t^2}.$$

Putting now

$$A = \kappa \int \frac{\rho(\sum_{(l)} \dot{x}_l^2) dS}{4\pi r}, \quad B = \kappa \int \frac{\rho r dS}{4\pi}, \dots \dots \dots (15)$$

we have

$$\Delta A = -\kappa \rho \sum_{(l)} \dot{x}_l^2, \quad \Delta B = -2\kappa \rho$$

and so

$$\Delta \left(g_{44} - \frac{1}{2} \kappa^2 \beta^2 + 2A + \frac{1}{2} \frac{\partial^2 B}{\partial t^2} \right) = \kappa(\rho + 3p + \rho P) - \kappa^2 \rho \beta.$$

We now consider the case of a number of separate bodies; more in particular we consider an astronomical system. In each body p and P may then be considered to be only dependent of the field of the first order, produced by the body itself, and consequently do not change. The term $-\kappa^2 \rho \beta$ can be divided into as many terms as there are bodies, in such a way that say in the first body

$$-\kappa \rho \beta = -\kappa \rho \sum_a \beta_a$$

In this sum the term produced by the first body does not change. It constitutes, together with $3p + \rho P$ a nearly invariable quantity of the first order. If we put

$$\rho + 3p + \rho P - \kappa \rho \beta_1 = \rho'$$

in the first body (and a similar expression in the others), we may consider ρ' to be the density; in (13), (14), (15) we then may replace ρ by ρ' . Indicating now again ρ' by ρ , we find

$$\Delta \left(g_{44} - \frac{1}{2} \kappa^2 \beta^2 + 2A + \frac{1}{2} \frac{\partial^2 B}{\partial t^2} \right) = \kappa \rho - \kappa^2 \rho(\beta), \quad \dots \quad (16)$$

where the parentheses about β mean that in each body the part, relating to the body itself, is to be omitted.

The solution of (16) is

$$g_{44} = 1 + \kappa \beta + \frac{1}{2} \kappa^2 \beta^2 - 2A - \frac{1}{2} \frac{\partial^2 B}{\partial t^2} + \kappa^2 \int \frac{\rho(\beta) dS}{4\pi r} \quad (17)$$

Suppose now the bodies to be spheres in case they rest (radii R_1, R_2, \dots, R_n); as they are moving they will have a somewhat other form in consequence of the contraction in the direction of the motion, but the values furnished by (14), (15) and the last term of (16) will vary in consequence of this only in terms of the third order; this variation we must neglect. Also in (13) we may do so for the calculation of the β which occurs in the third and the sixth term of (17). As to the second term of (17), however, we must consider the contraction in the proportion $(1 - \frac{1}{2} \sum_{(i)} \dot{x}_i^2) : 1$. Putting

$$\int_{(i)} \rho dS = 4\pi m_i,$$

we get from (13)

$$\beta_i = -\frac{m_i}{r_i} \left(1 - \frac{1}{2} \sum_{(i)} \dot{x}_i^2 \right)$$

r_i representing the distance from the i -th body, and the dimensions of the body being small with respect to r_i . Calling the coordinates x_1, x_2, x_3 henceforth x, y, z , so that $\dot{x}_i, \dot{y}_i, \dot{z}_i$ represent the components of the velocity of the i -th body, and supposing $(\dot{x}_i, \dot{y}_i, \dot{z}_i)$ to be almost equal in each point of the i -th body, we obtain from (14)

$$g_{14} = 2\kappa \sum_i \frac{m_i \dot{x}_i}{r_i}, \quad g_{24} = 2\kappa \sum_i \frac{m_i \dot{y}_i}{r_i}, \quad g_{34} = 2\kappa \sum_i \frac{m_i \dot{z}_i}{r_i}.$$

Representing the velocity of the i -th body by v_i , we get from (15), as the dimensions of the body are small with respect to r_i ,

$$A = \kappa \sum_i \frac{m_i v_i^2}{r_i}, \quad B = \kappa \sum_i m_i r_i.$$

In the last term of (17) we may consider (β) to be constant and so we have

$$-\alpha^2 \sum_i \frac{m_i}{r_{i,j}} \sum_{j \neq i} \frac{m_j}{r_{i,j}}$$

where $r_{i,j}$ represents the distance of the i -th body from the j -th.

We so obtain

$$g_{44} = 1 - \alpha \sum_i \frac{m_i}{r_i} + \frac{1}{2} \alpha^2 \left(\sum_i \frac{m_i}{r_i} \right)^2 - 2\alpha \sum_i \frac{m_i v_i^2}{r_i} - \frac{1}{2} \alpha \sum_i m_i^2 r_i - \alpha^2 \sum_i \frac{m_i}{r_i} \sum_{j \neq i} \frac{m_j}{r_{i,j}}$$

Putting

$$\alpha m_i = 2 k_i,$$

we have

$$\left. \begin{aligned} ds^2 = & \left(1 - 2 \sum_i \frac{k_i}{r_i} + 2 \left(\sum_i \frac{k_i}{r_i} \right)^2 - 4 \sum_i \frac{k_i v_i^2}{r_i} - \sum_i k_i r - 4 \sum_i \frac{k_i}{r_i} \sum_{j \neq i} \frac{k_j}{r_{i,j}} \right) dt^2 \\ & + 8 \sum_i \frac{k_i}{r_i} (x_i dx + y_i dy + z_i dz) dt - \left(1 + 2 \sum_i \frac{k_i}{r_i} \right) (dx^2 + dy^2 + dz^2) \end{aligned} \right\} \quad (18)$$

where j in the last term of g_{44} does not take the value i .

This is the field required.

Physiology. — “*Researches on the function of the sinus venosus of the frog's heart*”. By E. BROUWER. (Communicated by Prof. HAMBURGER).

(Communicated in the meeting of May 27, 1916).

I. *Effect of CaCl₂, KCl, NaCl and osmotic pressure.*

Introduction.

As we know the myogenous theory of the heart supposes the impulse to the automatic motion of the heart to originate in the muscular substance of the sinus venosus. There must be a centre there whence the rhythmic stimulus takes its origin, which stimulus is transmitted through auricle and ventricle. From a chemical point of view there is no longer anything mysterious about the occurrence of such periodical stimuli, since BRÉDIG has made us acquainted with the periodical contact-catalysis.

The reader will remember his experiment: a mercury-surface is covered with a solution of hydrogenperoxyde. A red layer of HgO is formed, but after a short time it disappears and O₂ being set free, a pure mercury-surface is the result. This phenomenon is repeated rhythmically.

Now it must be esteemed of the greatest importance to get acquainted with the chemism of the stimulus originating in the sinus venosus.

These considerations induced Prof. HAMBÜRGER to suggest that I should *enter upon a systematic investigation of the effect of various chemical and physico-chemical agents on the place of the chemism and their effect, restricting myself to the sinus venosus.*

The effect of salts and other substances on the heart as a whole, has indeed been investigated, but the matter then becomes too complicated to enable us to arrive at conclusions as regards the chemism of the sinus. The conclusions drawn from the study of the isolated ventricle or the auricle-ventricle system too cannot be immediately applied to the sinus. (See also summary on p. 464). In this connection I may quote the opinions of HERING and SAKAI as regards KCl. The former supposes that with respect to the frequency the "nomotope" centres are inversely proportionate with the "heterotope" ones. He supposes that KCl has a stimulating effect on certain "heterotope" centres¹⁾. SAKAI on the other hand supposes that the sinus is stimulated into greater frequency by KCl.

Method of Investigation.

After some fruitless attempts to register the contractions of the *isolated* sinus, I have made use of ENGLMANN'S suspension-method. The fluid was driven through the heart from the vena cava inf. behind (below) the liver, mainly as suggested by MINES. The following modification, however, seems to me of some importance. Besides one or both of the aortas also both venae cavae sup. were cut through at some distance from the auricle, so that the fluid could also flow away through these. If this is not done, blood will remain in the veins long after the experiment has begun. This must affect the frequency. If the fluid passing through the heart impedes automatism, such a vein will retain its former rhythm. Every contraction of the vein is transmitted to the auricle, which will, therefore, beat faster than if auricle and veins had been in contact everywhere with the same perfusion fluid.

The difficulty is that auricle and ventricle are not supplied with so much fluid, and may under certain circumstances determine the rhythm, this can, however, be easily ascertained. Though I have constantly paid attention to this, I have observed it but seldom. The curves relating to these experiments have of course not been used for this publication.

When the heart of large esculents had thus been treated, the pericardium parietale was removed, the frenulum was cut through,

¹⁾ By "nomotope" centres HERING (Centralbl. f. Phys. Vol. 19. 1905, p. 129) means the places, from which the normal stimulus originates; "heterotope" centres are those from which it originates in abnormal conditions.

the ventricle was carefully turned up and, if necessary, fixed by a piece of wadding.

The parietes of the sinus then lying bare were taken with a small "serre fine", which transmitted the contractions by means of a very light lever to the sooted paper, so that they were magnified about ten times. Special care was taken that the other parts of the heart should either not modify the curves at all or modify them but slightly. This can be done very easily.

As a perfusion fluid I used a solution of RINGER containing: 0,6 % NaCl, 0,0075 % KCl, 0,01 % NaHCO₃, whilst the CaCl₂ percentage was in the first experiments 0,01 % CaCl₂ 6 aq. and afterwards 0.01 % CaCl₂ without crystallization water: that is about twice as much. [The CaCl₂ solution obtained by weighing the crystallized salt was titrated afterwards]. This fluid was gradually modified in accordance with the nature of the experiments. The percentage of NaHCO₃ remained the same, however, to prevent changes into H⁺ and OH⁻.

The deviations obtained on the sooted paper varied from 1 to 5 millimetres and were also during the experiments highly variable, thus forming a contrast with the frequency. The latter decreased a little at first, but when the heart had once become hypodynamic, it remained surprisingly regular; also when after a series of other fluids, the original solution was taken again, the frequency returned entirely or almost entirely to its former value.

In this connection it may be noticed that for the heart-action the automatism of the auricle is of much greater importance than its contractility.

Tonus-fluctuations have been observed but seldom.

CaCl₂.

The diagrams I and II relate to the experiments with CaCl₂.

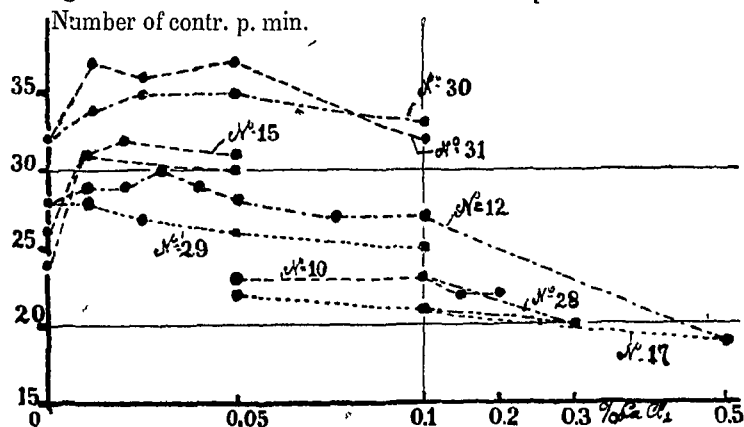

Diagram I. Effect of CaCl₂ on the frequency of the sinus venosus; dose from 0 to 0.5 ‰.

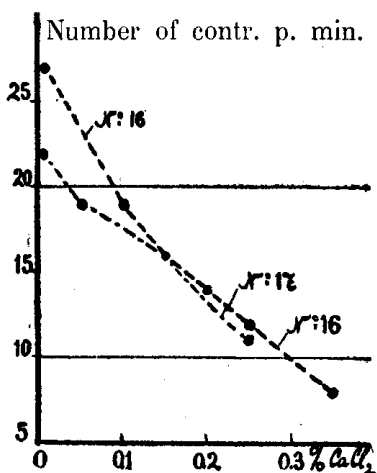

Diagram II. Effect of excessive dose of CaCl₂ on the frequency of the sinus venosus.

They show that the concentration of the salt was gradually increased or decreased. Before passing on to another stage I waited till the frequency had become constant. Mostly this was already the case after 15 minutes except with weak concentrations. A return from low to high concentrations resulted in a rapid modification of the frequency (fig. 1).

In these as in the following experiments the temperature varied between 13° and 17°, but was the same during each experiment.

Increase of the CaCl₂ percentage



Fig. 1. Transition at once from RINGER's fluid without CaCl₂ to the same fluid with 0.005 % CaCl₂. Effect after 5 min. Time denoted in min.

of the perfusion fluid resulted in a slow but uniform decrease of the frequency (fig. 2), which lasted until the contraction-height became imperceptible.

The deviation increased distinctly at first (fig. 2) and decreased regularly afterwards. In the two experiments with high concentrations the contractility had disappeared at ± 0.3% CaCl₂.

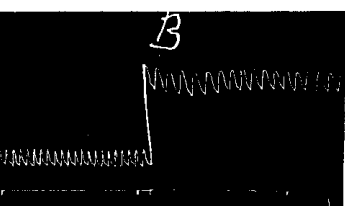

Fig. 2. Transition from RINGER's fluid with 0.005 % CaCl₂ to the same fluid with 0.1 % CaCl₂. Effect after 5 min. Time denoted in half minutes.

The maximum contractility can of course not be determined with accuracy from these experiments. Probably it is not far from 0.1 % CaCl₂.

The tonus increases. This was not observed regularly, probably owing to the diminutive size of the object and its delicate structure. At the highest concentration, however, the sinus was strongly contracted whilst the limp veins had contracted into threads in which there was hardly a lumen visible.

The osmotic pressure not being kept at the same height during the experiments, its influence was studied separately afterwards. The modification effected by it amounted to 3 beats per minute at most.

Decrease of the CaCl_2 percentage

caused an increased frequency, which was small indeed, but was met with in all the experiments.

A very remarkable fact was that from a certain concentration upwards the frequency hardly ever (diagr. I) increased any longer, but decreased, and that sometimes rather much.

When the concentration had arrived at 0, the sinus stopped entirely after a shorter or longer time.

The fact is that the points of the diagrams at $\text{CaCl}_2 = 0\%$ have no right of existence. Therefore it should be expressly stated that they were noted down as long as it was barely possible to count the contractions or when at least the fluid containing no CaCl_2 had for a long time been driven through the sinus. The latter also holds good for the diagrams on KCl (III and IV).

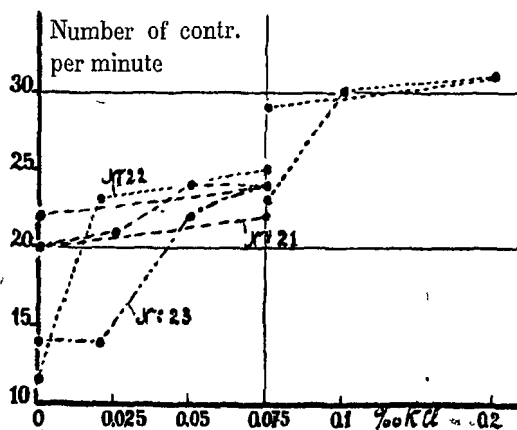

Diagram III. Effect of KCl on the frequency of the sinus venosus. CaCl_2 6 aq. = 0.01 %.

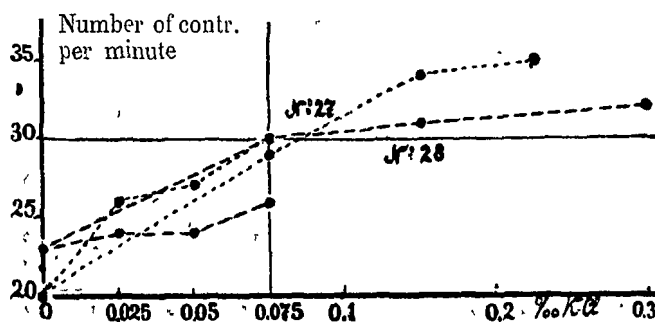

Diagram IV. Effect of KCl on the frequency of the sinus venosus. CaCl_2 (without water of crystallization) = 0.01 %.

Moreover some experiments were made on the withdrawal of all CaCl_2 at once. Here too we obtained — though not always — first an increased frequency, which was followed by a decrease.

Number 17. 28-1-16 $t = 13^{\circ}$ *Rana esculenta*, experiment with the sinus venosus; both venae cavae sup. and one of the aortas cut through, the other one tied off.

After some other fluids:

2.40. RINGER being led through, number of contractions per min.: 22.

2.44. RINGER without CaCl_2 . Number of contractions per minute: after 5': 24; after 10': 24; after 15': 22; after 20': 22; after 25': 22; after 30': 23; after 45': 21; after 50': 22; after 55': 21; after 60': 21.

3.16. led through: RINGER. Frequency per minute after 5': 22; after 10': 22; after 15': 22.

As regards *deviation* and *tonus* the former regularly decreased to 0; the latter did not always manifest itself in the curves, but likewise tends to a decrease.

Hence the sinus and ventricle automatism differ considerably as regards frequency. The sinus is retarded by an addition of CaCl_2 to the physiological doses, the ventricle is stimulated into greater frequency, likewise retarded, however, in higher concentrations. The difference may perhaps after all be reduced to a difference in degree, for starting from RINGER's solution without CaCl_2 I observed when I passed on to a weak concentration, a more rapid rhythm also of the sinus, but at higher concentration a smaller frequency again. The difference is that the maximum frequency for the sinus lies below the physiological concentration of CaCl_2 and that for the ventricle above it. This makes it clear why they may behave differently at or near the usual concentration.

KCl.

The diagrams III and IV relate to the *frequency* when the quantities of KCl are changed. In III we had 0.01% of CaCl_2 6 aq and in IV 0.01% CaCl_2 without water of crystallization. See also fig. 3.



Fig 3. Retardation of the rhythm by withdrawal of KCl. At K RINGER flowed through. At U (70' after K; the last quantity of KCl had been withdrawn for 40'. Time marked in half minutes.

An increased KCl percentage caused an increased *frequency* until the contractions became too slight to be registered, whilst a decreased KCl perc. resulted in a decreased frequency,

Hence under the action of KCl the sinus likewise behaves in a manner directly opposite to that effected by CaCl_2 ; the differences in the diagrams are, however, more pronounced. No reasons have been found hitherto which may justify the conclusion that, also with regard to KCl, there is only a difference in degree between auricle and ventricle.

Just as with CaCl_2 the *contractility* did not differ from that of the ventricle. It decreased at an increased KCl percentage and could hardly be registered already in diagram III at 0.02% and in diagram IV at 0.03%. A decrease of the KCl percentage, however, caused it to increase. When a solution containing no KCl was led through the sinus, the contractions became indeed smaller after the process had lasted for hours, but they never disappeared, so that it cannot be determined from these experiments whether KCl is absolutely necessary for the sinus-automatism.

Further the experiments gave an impression that the sinus as a rule responded more slowly to changes in the concentration of the KCl than of the CaCl_2 . To concentration changes of the NaCl it mostly responded more quickly than to changes in the CaCl_2 percentage.

As regards the *tonus* it was discovered that, just as with the ventricles, it decreased when the KCl perc. was raised and increased when it was lowered.

NaCl.

The decrease of concentration caused by NaCl was investigated only while the osmotic pressure was kept constant by means of cane-sugar.

Again the *frequency* was directly opposite to that of the isolated ventricle, as appears from the diagrams V, where 0.01% of CaCl_2 6 aq had been added, and VI where 0.01% without aq. was used. See also fig. 4. When the amount of CaCl_2 was small, greater quantities of NaCl could be withdrawn than when it was greater. If the concentration was weaker than the minimum values marked on the diagrams or even equal to 0, then the concentrations stopped within a few minutes, which makes a great difference with KCl and CaCl_2 .

The *contraction-height* mostly increased a little at first; then it

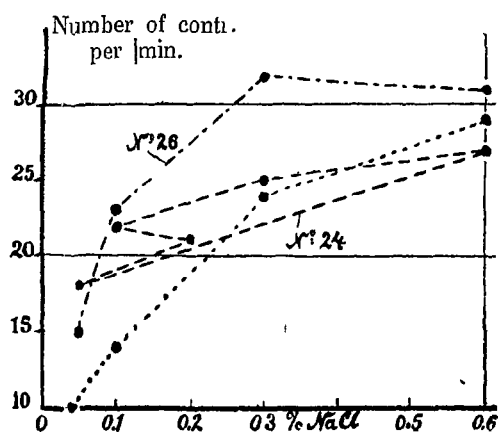

Diagram V

Decrease of the NaCl $\%$, the osmotic pressure being kept constant by cane sugar. Effect upon the frequency. CaCl₂ aq = 0,01 $\%$.

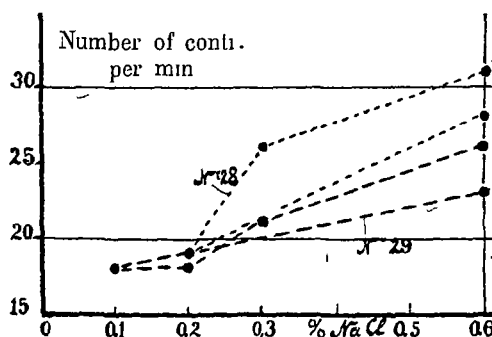

Diagram VI

Decrease of the NaCl $\%$, the osmotic pressure being kept constant by cane-sugar. Effect on the frequency. CaCl₂ (without water of crystallisation) = 0,01 $\%$.



Fig. 4 Effect of NaCl. At R change from NaCl 0,1 $\%$ to NaCl 0,3 $\%$. Effect after 5 minutes. At T of the same experiment, change from NaCl 0,3 $\%$ to ordinary Ringer. Effect after 5'. Time marked in half minutes.

strongly decreased between 0,3 $\%$ and 0,1 $\%$ (fig. 4). To what extent the increase must be attributed to the cane-sugar or to the withdrawal of NaCl as such, cannot be stated with certainty.

On the *tonus* I have only a few observations in two experiments. In both experiments it increased when NaCl was withdrawn, whilst a return to the original quantity of NaCl caused a decrease.

Increase of osmotic pressure by cane sugar and urea.

Glucose was precluded, its action on the heart being too specific. This is according to most authors not the case with cane-sugar, and urea was taken because, in contrast with other tissues it is marked, according to LUSSANNA, by a certain osmotic activity as regards the heart.

A comparison of the diagram VII and VIII brings to light the great difference cane-sugar decreases the *frequency*, urea does not alter it in the least. In order to be absolutely certain we have sub-

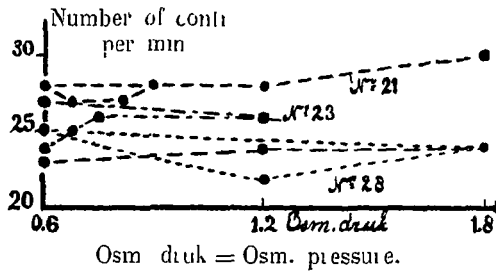

Osm druk = Osm. pressure.
Diagram VII.

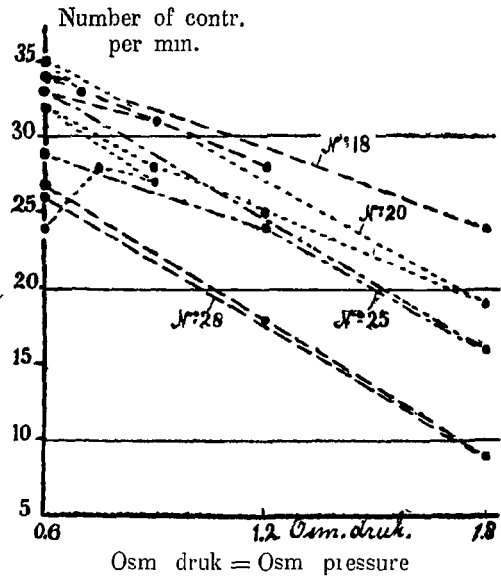

Osm druk = Osm. pressure
Diagram VIII

Effect of an increased osmotic pressure on the frequency of the sinus venosus with *urea*.
Osmotic pressure expressed in ‰ NaCl

Effect of an increased osmotic pressure on the frequency of the sinus venosus with *cane-sugar*.
Osmotic pressure expressed in ‰ NaCl

mitted the same sinus successively to the action of cane-sugar and urea (N° 28) and again we obtained the same result

Now it may be looked upon as certain that cane-sugar will be osmotically active as regards the muscular fibres of the sinus

The fact that urea shows so little activity in such a strong concentration, thus differing so much from a substance possessing osmotic activity, suggests the conclusion that the muscle fibres of the sinus are permeable $\text{CO}(\text{NH}_2)_2$. If this is the case, an addition of urea must cause a withdrawal of water -- and consequently a smaller

Number 29; 24-3-16, $t = 14^\circ$; 10.50 h R. esculenta; sinus venosus perfused.
Cut through both aortae and both venae cavae sup.

The experiment was continued at 25-3-16 and summarised as follows.

Letter on the curve	Time	Fluid	Number of contr. per 1' after		Osmotic pressure in ‰ NaCl	Remarks
			5'	10'		
L'	11.30	RINGER	before the exp. 23		0.6	$t = 13^\circ$
M' N'	11.33	RINGER + urea	21	24	1.2	
Q' P'	11.47	RINGER + urea	23	24	1.8	
Q' R'	11.58	RINGER	26	25	0.6	

frequency -- before the ultimate quantity has been diffused. It was found that in nearly all the experiments the number of contractions had indeed decreased somewhat after 5', and had reached its original value again after 10' or 15'. (See table p. 463).

In weak concentrations the effect of both substances on the *excursion* was a favourable one; in greater concentrations it was now favourable, now unfavourable.

The effect on the *tonus* was so little pronounced that we must abstain from expressing an opinion on the subject.

Summary.

From these experiments it appears that there is indeed a *great difference between the sinus and the isolated ventricle of the frog; they behave in directly opposite ways, as regards frequency under the influence of CaCl₂, KCl and NaCl.*

When the physiological dose is increased KCl heightens and CaCl₂ lowers the frequency.

When the physiological dose is diminished CaCl₂ slightly raises the frequency, and KCl and NaCl retard it.

The fact that a copious withdrawal of CaCl₂ mostly lowers the frequency led to the supposition that the different behaviour of sinus and ventricle towards this salt, is merely a difference in degree. These facts were not observed in the case of KCl and NaCl.

Tonus and deflection are like those of the ventricle. A slight increase of the CaCl₂ perc. of RINGER's fluid has a positive inotropic effect; with great quantities the effect is negative inotropic. The tonus is always raised.

An increase of the KCl percentage has a negative inotropic effect and lowers the tonus.

A decrease of the CaCl₂ percentage likewise lowers the tonus and results in a negative inotropic effect.

A decrease of the KCl percentage has a positive inotropic effect and increases the tonus.

A slight decrease of the NaCl percentage results perhaps in a positive inotropic, a great decrease in a negative one. Probably the tonus is heightened.

An increase of osmotic pressure by means of cane-sugar gives negative inotropic results, a quantity of uræa with the same osmotic pressure leaves the frequency the same. It is highly probable that the muscular cells of the sinus are permeable to uræa.

Further it appeared from these experiments that of frequency, tonus and deflection the former is by far the most constant.

LITERATURE.

BREDIG u. WEINMAYR. Zeitschr. f. physik. Chem. Vol. 42. 1903, p. 601.

HERING. Pflüger's Archiv. Vol. 161. 1915, p. 544.

SAKAI. Zeitschr. f. Biologie. N. F. Vol. 46. 1914, p. 505.

MINES. Journal of Physiology Vol. XLVI. 1913, p. 188.

LUSSANA. Arch. di Fisiol. Vol. VI. 1909, p. 473.

May 1916.

*Physiological Laboratory of the
University of Groningen.*

Astronomy. — “Contributions towards the determination of geographical positions on the West coast of Africa” IV. By C. SANDERS. (Communicated by Prof. E. F. VAN DE SANDE BAKHUYZEN).

(Communicated in the meeting of June 24, 1916).

1. Introduction.

My last paper¹⁾ on my determinations of geographical positions on the West coast of Africa dates from 1908; I describe there what I did in that direction in the years 1903—1906. In 1906 I was in Europe for some time, but in May 1907 I had returned to Chiloango, while in the mean time my stock of instruments had been augmented by a ZEISS telescope of 80 mm. aperture and 120 cm. focal distance.

The principal purpose for which I had obtained this telescope was to be able to observe occultations of stars by the moon, in order in this way to improve my results for the absolute longitude of Chiloango, which I had previously determined by means of lunar altitudes. At the same time I wished to try to make other observations, which might be of use scientifically, my especial aim being the observations of eclipses and other phenomena of the satellites of Jupiter; while, when the telescope had only been in my possession for a short time, I had an opportunity of observing the transit of Mercury on Nov. 14th 1907, at least partially. I published the result of these observations in 1908²⁾. At the same time, some of the observations, especially those of the reappearance in occultations, were made very difficult by the circumstance that my telescope had provisionally been provided with an azimuthal mounting, which was to be replaced later by a parallactic one. This proved, however, to be difficult to accomplish and finally I ordered a second telescope exactly the same as the first, but mounted parallactically.

¹⁾ C. SANDERS. Bijdragen tot de astronomische plaatsbepaling op de Westkust van Afrika. (III). Versl. Akad. Amst. 17, 66—84. 1908. (Proceedings XI. p. 88).

²⁾ C. SANDERS. Waarneming van den overgang van Mercurius Versl. Akad. Amst. 17, 84—85. 1908. (Proceedings XI. p. 108).

With this telescope, which I received in July 1909 and to which a ring-micrometer was added, I then continued my observations, principally of occultations and of phenomena of the satellites of Jupiter, while I succeeded in 1910 in obtaining some observations of HALLEY'S comet. All this time, however, I had constant trouble from the weather conditions, as the sky usually became clouded over in the evening, and moreover in the years which followed, my astronomical work was more and more interrupted by my other occupations, so that at the end of 1910 I was obliged to temporarily close my observations of occultations. In the last three years I had been able to obtain 24 observations, although almost exclusively of disappearances. Of these observations 10 concerned known stars, for the occultations of which I could make the necessary preparations, while 14 were of unknown stars, which had to be first identified by diagrams which I made for the purpose and had subsequently to be accurately observed in the meridian.

The occultations of the known stars I soon afterwards calculated and made use of for the determination of the longitude. For these calculations I used both BESSEL'S method and an approximation method given by OUDEMANS and refined still more by E. F. VAN DE SANDE BAKHUYZEN, which in most cases yielded sufficiently accurate results.

Of course at the moment I could only make use of approximate elements, especially as regards the places of the moon, and although that might now be corrected, it appears to me preferable to wait with my final calculations, until I have at my disposal sufficiently accurate positions for all the stars observed.

For only 7 observations I made calculations with provisionally corrected elements, in which (1) I introduced a general correction to the R. A. of the moon of $+0^{\circ}40'$, and corrected the declination in accordance with this, (2) I assumed the lunar parallax according to NEWCOMB, and (3) for the semidiameter of the moon I used the value $15'32''68$, which was deduced by Prof. BAKHUYZEN from occultations and heliometer-observations.

Thus I obtained as results for the longitude of my place of observation

1908	June 16	P XIX 369	Reapp.	$-48^m 31^s 2$
	Sept. 30	ψ Ophiuchi	Disapp.	25.0
	Nov. 6	ν Piscium	„	31.2
1909	March 28	ϵ Geminorum	„	30.8
1910	March 16	ν_1 Tauri	„	30.1
	„ 20	ν_2 Canceri	„	30.0
	May 20	ζ_2 Virginis	„	28.7

Taking into consideration that the 2nd result has less weight, the mutual agreement may be considered satisfactory. When we give the 2nd result a weight of 0.5, the mean result becomes

$$- 48^m 29^s 9$$

while formerly from the observation of altitudes of the moon

$$- 49^m 32^s 3 \pm 1^s 0.$$

was found.

Probably in a final calculation, as the correction of the mean longitude of the moon for the mean epoch of my observations was about $+ 0^s 47$, a somewhat greater eastern geographical longitude will be found, and the new result, even from these seven stars alone, will come somewhat nearer to the earlier one.

In the years 1911 and 1912 I was obliged to restrict myself to the absolutely necessary time determinations. My supply of chronometers was in the mean time augmented in August 1909 by one from DENT, which was regulated to sidereal time, and as both my other chronometers by HEWITT and HOWWU began to show signs of old age, I ordered in 1910 another chronometer from A. DE CASSERES in Amsterdam, which I received in February 1911. This chronometer DE C. 769 had shown a very regular rate in a six months test by Mr. ROOSENBURG at the Amsterdam branch of the Dutch Meteor. Institute. It preserved this quality in Africa, so that I was able to use it as a standard instrument. This was of value to me, not only for the accuracy of my observations, but also because in connection with the official introduction on Jan. 1st 1912 of the time of the 15th meridian east of Greenwich (= Middle European time) I was requested by the Portuguese Government to determine the time, and to distribute it telegraphically or telephonically in the district, for which purpose my HOWWU chronometer was deposited at Cabinda, the capital of the district.

My hope of being able in these years to carry out my long cherished plan of making determinations of geographical position for one or two points on the Lukula river, unfortunately came to nothing, but a more favourable time began again for my observations after I definitely changed my place of residence from Chiloango to Matuba, in 1913. In the following year I was able to make a determination of the geographical coordinates of my new domicile and also of the capital Cabinda.

This was the last of my observations with the old Universal

30*

Instrument, as in the mean time I had ordered a new and larger instrument from the firm of SARTORIUS in Göttingen. At the end of 1914 I again went to Europe for six months, and on my return in the summer of 1915 I was able to take the new instrument with me, after it had been subjected to a first examination at the observatory in Leiden.

Although I have since made a considerable number of observations with this instrument, it will be better to discuss these in later papers. The publication of my occasional observations with the ZEISS-telescope, in so far as these may prove to be of scientific value, will also be better delayed till that of the final discussion of my occultations. In the following paper I shall therefore confine myself to the determinations of the coordinates of Matuba and Cabinda.

2. *Determination of the latitude of Matuba.*

In July 1913 I made a first determination of the latitude of Matuba by meridian-zenith-distances, and I afterwards repeated it in Febr. and March 1914. A short description of my installation there may here be given.

Matuba is about 400 meters from the coast, and lies more than 100 meters above sea level. My observatory consists of three apartments, of which the two outer ones are provided with moveable roofs. In these my universal instrument and the equatorial ZEISS telescope are mounted upon solid piers. Here on the firm ground a much greater stability is obtained than at Chiloango. In the inner room, which is arranged as a study, stand the chronometers in a closed cupboard, which is kept dry by calcium chloride. The observatory stands free from my house, but is connected with it by a covered passage.

The first determination of the latitude of my observatory was made in 1913 from July 6th to July 22nd, and I proceeded in exactly the same way as before in my second determination of the latitude of Chiloanga¹⁾, i.e. that observations were made exactly in the meridian, so that only one pointing could be obtained of each star. In order to eliminate as far as possible the systematic division errors and the flexure of the telescope, the observations were made in six different positions of the vertical circle, namely with the zenith point

¹⁾ Versl. Akad. Amsterdam 17 73—78; Proc. 11 (95—101) 1908.

brought successively to 0° , 30° , 60° , 90° , 120° and 150° , and each time I observed two stars which culminated to the north and two which culminated to the south of the zenith, as far as possible at the same zenith-distance. In order to eliminate the zenith-point one star was each time observed in each position of the instrument. Comparing the differences thus obtained in the six positions between the latitude found by the northern and the southern stars $\varphi_N - \varphi_S$; with the corresponding differences formerly obtained at Chiloango (the mean zenith-distance in the Chiloango and the Matuba observations do not differ much, and in the 2nd determination at Chiloango observations were made in the same 6 positions of the circle) I found a considerable abnormality in one of the positions of the circle which rendered the course of the results less simple than in the previous series. This made me suspect that the vertical circle might have become slightly deformed during the transport, a few local injuries were plainly visible, and it was possible that these might have been accompanied by a very slight general deformation.

In order to arrive at a greater certainty on this point, and as in any case it was desirable to check the results obtained by a new series of observations, I decided to undertake a second determination, and I accomplished this plan in 1914, from Febr. 22nd to March 14th. In this observations were again made in 6 positions of the circle, but this time the zenith point was brought to 15° , 45° , 75° , 105° , 135° and 165° , and the number of observations in each position was doubled. Of the 8 observations 4 now concern northern, and 4 southern stars, of which two were each time made in each position of the instrument. Each evening (i.e. in each position of the circle) the same 8 stars were observed.

The results from both these series of observations are given below. For the sake of brevity I leave out the original readings of circle and level and the different reductions applied to them and give only the latitude φ according to each observation and thereby for each position of the circle the mean results from the 2 or 4 north and south stars φ_N and φ_S respectively, and also their differences and half sums $\varphi_N - \varphi_S$ and $\frac{1}{2}(\varphi_N + \varphi_S)$. The positions of the instrument are indicated in column P by the letters R = circle right of observer and L = circle left of observer. This was the simplest way of noting the observations at the time, but it leads to the same letter indicating a different position of the axis for a north and for a south star, and also NR and SL and similarly NL and SR referring to the same position of the axis. Column Z contains the zenith distance in full degrees, with the letters N (North) and S (South).

DETERMINATION OF THE LATITUDE OF MATUBA 1ST SERIES.

Date Zenith point	Star	Z	P	φ_N	φ_S	$\varphi_N - \varphi_S$	$\frac{\varphi_N + \varphi_S}{2}$
1913					-5°16'		-5°16'
July 19,20 0°	γ Ursae maj.	55°N	R	61''63			
	β Centauri	55 S	L		54''40		
	γ Bootis	44 N	L	62.71			
	α Lupi	42 S	R		53.30		
	Mean			62.17	53.85	-8''32	58''01
July 22 0°	β Centauri	55 S	R		54.45		
	α Lupi	42 S	L		57.34		
	α Bootis	25 N	L	63.35			
	γ Bootis	44 N	R	60.44			
	Mean			61.90	55.90	-6.00	58.90
July 27 30°	γ Ursae maj.	55 N	R	59.53			
	α Bootis	25 N	L	56.59			
	β Centauri	55 S	L		59.61		
	α^2 Centauri	55 S	R		62.57		
	Mean			58.06	61.09	+3.03	59.58
July 6 60°	γ Crucis	51 S	R		60.16		
	β Crucis	54 S	L		60.56		
	α Ursae maj.	62 N	R	58.30			
	α^1 Ursae maj.	61 N	L	58.72			
	Mean			58.51	60.36	+1.85	59.44
July 7 90°	β Crucis	54 S	R		61.07		
	α Centauri	48 S	L		61.70		
	α Ursae maj.	62 N	L	53.96			
	α^1 Ursae maj.	61 N	R	53.33			
	Mean			53.65	61.39	+7.74	57.52
July 9 120°	α Crucis	54 S	R		57.38		
	α Ursae maj.	62 N	L	[57.20]			
	α^1 Ursae maj.	61 N	R	55.25			
	α Centauri	48 S	L		60.47		
	Mean			56.80	58.93	+2.13	57.87
July 10 150°	α^1 Ursae maj.	61 N	R	66.14			
	α Centauri	48 S	L		57.02		
	γ Ursae maj.	55 N	L	65.00			
	α Centauri	42 S	R		58.17		
	Mean			65.57	57.60	-7.97	61.59

DETERMINATION OF THE LATITUDE OF MATUBA. 2ND SERIES.

Date Zenith point	Star	Z	P	φ_N	φ_S	$\varphi_N - \varphi_S$	$\frac{\varphi_N + \varphi_S}{2}$
1914					-5°16'		-5°16'
Febr. 22	α Columbae	29°S	R		56''79		
15°	β Columbae	31 S	L		58.81		
	γ Geminorum	28 N	R	58''67			
	δ Canis maj.	25 S	L		60.30		
	ν Geminorum	26 N	L	59.67			
	ν Argus	38 S	R		61.15		
	ε Geminorum	31 N	L	60.49			
	ζ_2 Geminorum	37 N	R	60.18			
	Mean			59.75	59.26	-0''49	59''51
Febr. 25	α Columbae	29 S	R		64.06		
45°	β Columbae	31 S	L		62.54		
	γ Geminorum	28 N	R	57.08			
	δ Canis maj.	25 S	L		[69.79] ¹⁾		
	ν Geminorum	26 N	L	55.71			
	ν Argus	38 S	R		62.20		
	ε Geminorum	31 N	L	57.66			
	ζ_2 Geminorum	37 N	R	57.52			
	Mean			56.99	62.93	+5.94	59.96
March 9	α Columbae	29 S	R		65.80		
75°	β Columbae	31 S	L		67.18		
	γ Geminorum	28 N	R	51.34			
	δ Canis maj.	25 S	L		66.12		
	ν Geminorum	26 N	L	56.93			
	ν Argus	38 S	R		63.88		
	ε Geminorum	31 N	L	52.02			
	ζ_2 Geminorum	37 N	R	54.01			
	Mean			53.57	65.74	+12.17	59.66

1) Probably an error in the reading.

DETERMINATION OF THE LATITUDE OF MATUBA. 2ND SERIES. (Continued).

Date. Zenith point	Star	Z	P	φ_N	φ_S	$\varphi_N - \varphi_S$	$\frac{\varphi_N + \varphi_S}{2}$
					-5°16'		-5°16'
March 12 105°	α Columbae	29°S	R		63''59		
	β Columbae	31 S	L		64.82		
	γ Geminorum	28 N	R	53''13			
	δ Canis maj.	25 S	L		64.41		
	ϵ Geminorum	26 N	L	55.56			
	ζ Argus	38 S	R		64.52		
	η Geminorum	31 N	L	50.78			
	θ Geminorum	37 N	R	52.12			
	Mean			52.90	64.34	+11''44	58''62
March 13 135°	α Columbae	29 S	R		58.06		
	β Columbae	31 S	L		58.58		
	γ Geminorum	28 N	R	56.95			
	δ Canis maj.	25 S	L		60.73		
	ϵ Geminorum	26 N	L	56.81			
	ζ Argus	38 S	R		60.34		
	η Geminorum	31 N	L	58.40			
	θ Geminorum	37 N	R	57.33			
	Mean			57.37	59.43	+2.06	58.40
March 14 165°	α Columbae	29 S	R		60.71		
	β Columbae	31 S	L		58.42		
	γ Geminorum	28 N	R	57.40			
	δ Canis maj.	25 S	L		59.42		
	ϵ Geminorum	26 N	L	59.57			
	ζ Argus	38 S	R		56.72		
	η Geminorum	31 N	L	57.52			
	θ Geminorum	37 N	R	59.23			
	Mean			58.43	58.82	+0.39	58.63

The refraction was calculated by the tables given by ALBRECHT; the declinations were taken from the Nautical Almanac, i.e. from NEWCOMB's fundamental catalogue. From all the observations of the same evening one zenith point was deduced which satisfied all of them in the best manner comparing the φ_R and φ_L , i.e. so that

$$\varphi_{NL} - \varphi_{NR} + \varphi_{SL} - \varphi_{SL} = 0;$$

the mean results are, however, independent of this. On July 19 and July 20 the observations were incomplete, but they supplement each other; from both days together follows as zenith point $48''40$, while on July 22nd, when another series of observations was made with the same position of the circle, $49''18$ was found (see preceding tables).

Where in the observations in each position of the circle the mean zenith distance of the north and the south stars was the same, the influence of systematic division errors and of flexure becomes eliminated in the half sum $\frac{1}{2}(\varphi_N + \varphi_S)$ for each position, and in that case it is certainly best to regard the mean of the 6 results as our final result. My second series of observations answered very perfectly to these requirements. In that series the same 8 stars were observed each evening and the mean zenith distance was for the northern stars $30^\circ.3$, for the southern ones $30^\circ.5$. (R.N. 33° , R.S. 33° , L.N. 28° , L.S. 28°). In the first series the zenith distances differ more; the mean differences $z_N - z_S$ lie for the various positions of the circle between -15° and $+13^\circ$ and their mean value is $+3^\circ$ (the mean values of z themselves were $z_N = 54^\circ$, $z_S = 50^\circ.5$, mean $z = 52^\circ$). But even in this case the method mentioned above will probably give the best results possible. We thus get:

1 st Series	2 nd Series
— $5^\circ 16' 58''46$	— $5^\circ 16' 59''51$
59.58	59.96
59.44	59.66
57.52	58.62
57.87	58.40
61.59	58.63

$$\text{Mean} \quad \text{— } 5^\circ 16' 59''08 \pm 0''60 \quad \text{— } 5^\circ 16' 59''13 \pm 0''27$$

The mean errors added to the final results were deduced from the mutual agreement of the 6 partial results. Of the latter themselves the mean errors are $\pm 1''48$ and $\pm 0''66$. Judged by this, the 2nd series proves to be much more accurate than the 1st. This is undoubtedly partly due to the fact that in the 2nd series twice

as many observations were made as in the 1st, but this can only partially explain the great difference. Our results give as the mean error for the mean of 2 pointings L, R, *after* correction for division errors and flexure, for the two series $\pm 2''09$ and $\pm 1''32$ respectively and it is not probable that the *actual* accidental errors would differ so much. Presumably, therefore, the somewhat great differences $z_N - z_S$ have caused an insufficient elimination of the systematic errors in the mean results for the single positions.

In the same way as previously (these Proceedings 4, p. 274, 1901) I deduced the correction-formulae for systematic division errors and flexure for both series from the values for $\varphi_N - \varphi_S$. For the former I found

$$\begin{aligned} 1^{\text{st}} \text{ series} &+ 3''69 \sin (2\alpha - 154^\circ 5) \\ 2^{\text{nd}} \text{ ,,} &+ 3''98 \sin (2\alpha - 169^\circ 3). \end{aligned}$$

The two formulae agree sufficiently, but, as I mentioned before, the first formula does not agree well with the results of observation, which suggested to me a possible deformation of the circle; for a proper agreement another term dependent upon 4α with a coefficient $3''13$ was necessary. but such a term can have little real significance. As, however, the formula for the 2nd series undertaken a year later agrees very well with the observations, and at the same time differs very little from those deduced from previous observations, my fear of a deformation of the circle must be regarded as unfounded. Probably the inequality of the zenith distances is the principal cause of the anomaly.

For the flexure assumed to be proportional to $\sin z$

$$\begin{aligned} 1^{\text{st}} \text{ series} \quad z &= -0''04 \sin z \\ 2^{\text{nd}} \text{ series} &+ 5.20 \sin z \end{aligned}$$

was found.

The two values are very discordant, and the result from the more accurate second series seems also to deviate very greatly from the earlier results; the divergence becomes less striking, if we do not assume that the influence of flexure must be proportional to $\sin z$. I shall return to this and in general to the systematic errors of my instrument in section 4.

In conclusion the most probable final result for the latitude of Matuba may be established. The 2nd series of observations I also calculated in a different manner, correcting the single results according to my formulae and then taking the mean value from them. My final result now became $-5^\circ 16' 59''13$, exactly the same as that deduced above, a new proof that this time I had succeeded in arranging

my observations in every way symmetrically. As m.E. for one pair of observations L., R. $\pm 1''20$ was now found, from which $\pm 0''25$ would follow for my final result.

In every way, therefore, the much greater reliability of the 2nd series is shown. However, the result of the 1st series happens to agree practically completely with that of the 2nd and it is therefore of no importance what relative weight we attach to each.

As my final result I accept:

Latitude of Matuba Observ.-Pier. —5° 16' 59"1 \pm 0"3.

3. *Determination of the latitude of Cabinda.*

For the purpose of the determination of the geographical position of Cabinda, which I undertook at the request of the Governor of the district, a concrete pier was built at a short distance from the meteorological post.

For the determination of the latitude I observed zenith-distances in the meridian, and I contented myself this time with 4 positions of the circle. But even with this restriction I was not able to carry out my programme (8 stars each time) completely in the short time at my disposal. For the determination of the time my HORNBY-chronometer stationed at Cabinda served. On Sept. 29th and 30th 1 and 2 observations respectively in position R were failures; the corresponding observations in position L are therefore omitted also. (See following table).

Very striking in these results is the rather marked deviation always in the same sense of 61¹ Cygni, and if we should assume that I had not pointed the telescope on 61¹ Cygni, but on a point nearer to the centre of gravity of the two stars, the deviation would become even greater. I considered, therefore, that I should not be justified in excluding these results.

Although the number of observations obtained in the various positions of the circle is very different, I think it is best to assume the simple mean value of the 4 partial results as my final result, and to deduce the m.e. from their mutual agreement. The observations clearly are less accurate than those at Matuba, due perhaps partly to a lesser stability of the pier.

I assume, therefore, retaining 61 Cygni.

Latitude Cabinda Observation-pier. —5° 33' 22"3 \pm 0"6.

If 61 Cygni is excluded, the results of the 4 days receive the corrections $+ 1''02$, $+ 0''54$, $+ 1''90$ and $+ 1''09$ and the mean result becomes —5° 33' 21"2.

DETERMINATION OF THE LATITUDE OF CABINDA.

Date Zenith point	Star	Z	P	φ_N	φ_S	$\varphi_N - \varphi_S$	$\frac{\varphi_N + \varphi_S}{2}$
1913					-5°33'		-5°33'
Septemb. 27	α Pavonis	51°S	R		23.66		
0°	ν Indi	42 S	L		21.29		
	ν Cygni	51 N	R	20.35			
	δ Cygni	44 N	L	25.75			
	ϵ Cygni	35 N	R	23.21			
	γ Pavonis	60 S	L		23.03		
	γ Gruis	32 S	R		20.88		
	ϵ Pegasi	30 N	L	17.56			
	Mean			21.72	22.22	+0.50	21.97
Septemb. 29	δ Cygni	44 N	L	19.53			
90°	ϵ Cygni	35 N	R	14.97			
	γ Pavonis	60 S	L		28.26		
	γ Gruis	32 S	R		25.10		
	ϵ Pegasi	30 N	L	15.27			
	ϵ Cephei	63 N	R	14.35			
	Mean			16.03	26.68	+10.65	21.36
Septemb. 30	δ Cygni	44 N	L	23.79			
45°	ϵ Cygni	35 N	R	19.76			
	γ Pavonis	60 S	L		25.10		
	γ Gruis	32 S	R		18.83		
	Mean			21.78	21.97	+0.19	21.87
October 1	δ Cygni	44 N	L	29.64			
135°	ϵ Cygni	35 N	R	22.60			
	γ Pavonis	60 S	L		23.72		
	γ Gruis	32 S	R		22.81		
	ϵ Pegasi	30 N	L	20.95			
	ϵ Ceph	63 N	R	25.44			
	ν Toucani	55 S	L		23.89		
	β Gruis	42 S	R		22.63		
	Mean			24.66	23.26	-1.40	23.96

4 *Systematic errors of the universal instrument.*a. *Division errors.*

I put together below the formulæ found in the different series of observations for the correction which must be applied to the readings α of the vertical circle of my instrument on account of the systematic division-errors. I confine myself everywhere to the terms in 2α .

Chiloango 1900—01	$\Delta\alpha = + 4''74 \sin (2\alpha - 169^\circ 2)$
„ 1903	$+ 5.15 \sin (2\alpha - 175.4)$
Matuba 1913	$+ 3.69 \sin (2\alpha - 154.5)$
Cabinda 1913	$+ 2.57 \sin (2\alpha - 171)$
Matuba 1914	$+ 3.98 \sin (2\alpha - 169.3)$

If we take into consideration the lesser accuracy of the results of the 1st series at Matuba and of the observations at Cabinda, the agreement of the 5 formulæ may be considered satisfactory. That in the division errors a term occurs of the assumed form with a coefficient of about \pm'' may be considered as proved and there is no reason to suspect any change with the time. That these errors are fairly large, is not surprising either, when we consider that the radius of the circle is only 70 mm.

Of course the values calculated from this will not represent the full amount of the division errors. At the same time the results of the most accurate series Matuba II do not point to large residual values. Whereas a comparison of the mean results for each position $\frac{1}{2} (\varphi_N + \varphi_S)$ with their mean value here leads to a m.e. of $\pm 0''66$, the m.e. is $\pm 0''82$ according to a comparison of the $\frac{1}{2} (\varphi_N - \varphi_S)$ with the formula including the flexure.

b. *Flexure of the telescope.*

In the table below are given, instead of the previously deduced coefficients of $\sin z$, the values of the flexure of the straight telescope (which thus represent the differences of the flexure of the objective and ocular halves) directly determined for the mean zenith distance of the series.

Chiloango 1900—01	$z = 53^\circ$	$\Delta z = - 0''48$
„ 1903	49	- 1.33
Matuba 1913	52	- 0.04
Cabinda 1913	44	+ 1.24
Matuba 1914	30	+ 2.62

Whereas the deviation from the previous results of those obtained in Cabinda might be explained by their smaller accuracy, the great deviation of the more accurate series Matuba II is very striking, and it becomes much more so, if the flexure is represented by $c \sin z$, and the coefficients c are compared. This cannot be attributed to accidental errors, (cf. the m. e. $\pm 0''82$ found above as against $\pm 0''66$) and there seem to be only two explanations possible, either we must assume a change with the time, or suppose that the flexure may even change its sign with the zenith distance. The latter was namely in the last series noticeably smaller than in all the previous ones.

At any rate it is necessary for each series to use the flexure deduced from it

5. *Determination of the longitude of Matuba and Cabinda.* -

The difference of longitude between Matuba and Chiloango, and later that between Cabinda and Matuba, was determined geodetically, which in the given circumstances seemed preferable.

a. *Determination of the geographical position of Matuba with respect to Chiloango.*

As early as 1901, I had connected my observation-pier at Chiloango with the flag staff of the Residency at Landana and in 1910 I connected my new observation place at Matuba with it also, by a tacheometric measurement of the road between the two places. I determined their relative magnetic coordinates, and, in order to be able to reduce these to astronomical ones, I made at the same time some determinations of the magnetic declination in Chiloango, in which the already determined azimuth of the harbour light provided me with the absolute orientation (once the sun was observed directly).

For the magnetic declination I obtained, with a needle of 86 mm. length

1910 Oct. 8 p. m.	14° 40' 35" West
„ 28 a. m.	39 31
Nov. 2 p. m.	43 53
„ 3 a. m.	38 2
„ 3 p. m.	52 55
„ 4 a. m.	35 33
„ 4 p. m.	50 22
<hr/>	
	Mean 14° 42'7 West

The values found for the magnetic coordinates of Matuba observ.-pier with respect to Landana flag staff follow here, and subjoined the astronomical coordinates calculated from them by means of the magnetic declination.

Matuba with respect to Landana

$$\Delta X_{mag} = + 1290^m 03, \quad \Delta Y_{mag} = - 7261^m 03$$

$$\Delta X_{ast} = + 3091^m 64 \quad \Delta Y_{ast} = - 6695^m 41$$

Adding to the latter the coordinates of Landana with respect to Chiloango observation-pier and taking the latter point as the zero point of coordinates we obtain

$$\text{Landana flag staff } X = + 686^m 29 \quad Y = - 2308^m 52$$

$$\text{Matuba observ. p. } X = + 3777.93 \quad Y = - 5003.93$$

If these are reduced to seconds of arc with the reducing factors:

$$1'' \text{ in the direction of the meridian} = 30^m 714$$

$$1'' \text{ ,, ,, ,, ,, ,, parallel} = 30.789$$

we find for the difference of latitude and longitude between Matuba and Chiloango and by means of these for the geographic coordinates of Matuba.

$$\text{Matuba—Chiloango } \Delta \varphi = - 4' 53'' 15 \quad \Delta \lambda = - 2' 2'' 7$$

$$\text{Chiloango } \varphi = - 5^\circ 12' 4'' 20 \quad \lambda = - 12^\circ 8' 4'' 5$$

$$\text{Matuba Obs. pier } \varphi = - 5^\circ 16' 57'' 4 \quad \lambda = - 12^\circ 10' 7'' 2$$

The latitude of Matuba derived from that of Chiloango thus differs by $1'' 7$ from the value as directly determined. This difference may be explained by accidental errors, in the first place by those made in the tachometric measurement. It is also possible that in this case local attractions played a part. Not long ago (May 1913) at Matuba a few hundred metres to the south of my observation-pier considerable land slides took place.

However this may be, according to the above calculation we may assume

$$\begin{aligned} \text{Longitude of Matuba Obs. P} &= - 12^\circ 10' 7''.2 \\ &= - 0^h 48^m 40^s.48. \end{aligned}$$

b. Determination of the Longitude of Cabinda.

As regards the determination of the difference of longitude between Cabinda and Matuba, it seemed to me most suitable to deduce this from the difference of latitude and an azimuth determination.

For this purpose I placed at Matuba at a distance of about 200 m. from my observation-pier a signal on a tripod, which was visible

from Cabinda and was lighted at night by an acetylene lamp with reflector.

For the coordinates of the signal with respect to the observation-pier I found by the measurement of azimuth and distance

$$\begin{array}{r} \Delta \varphi = - \quad 7''.14 \quad \Delta \lambda = - \quad 0''.24 \\ \text{thus Signal Matuba } \varphi = - 5^{\circ} 17' 6''.2 \quad \lambda = - 12^{\circ} 10' 7''.4 \end{array}$$

On Sept. 25, 1913 at Cabinda I made a time-determination by means of β Ceti in the east and α Ophiuchi in the west. The telescope was twice pointed on each star in each position of the instrument, at mean zenith distances of 59° and 57° respectively. As correction of the HÖRŪ chronometer I found:

$$\begin{array}{r} \text{by } \beta \text{ Ceti} \quad + 0^{\text{h}}54^{\text{m}}35^{\text{s}}19 \\ \quad \alpha \text{ Ophiuchi} \quad \quad \quad 35.46 \\ \hline \text{Mean} \quad + 0^{\text{h}}54^{\text{m}}35^{\text{s}}33 \end{array}$$

On Sept 27 I then determined the azimuth of the signal by means of the greatest digression of ν Ophiuchi (the observation of that of θ Ceti failed) and found, counting from the north through the east etc.

Azimuth Signal Matuba $A = 353^{\circ} 55' 26''.1$.

From this and from $\varphi' - \varphi = - 16' 16'' 1$ I calculated from ALBRICHT and from SCHÖLS in complete agreement:

$$\lambda' - \lambda = - 1' 43''.65$$

from which

Longitude Cabinda Obs. P. = $- 12^{\circ} 11' 51''.1 = - 0^{\text{h}}48^{\text{m}}47''.4$.

An error of $30''$ in the azimuth causes in the longitude one of $0''.14$ only.

Physics. — “*Note on the model of the hydrogen-molecule of BOHR and DEBIJE*”. By J. M. BURGERS. (Communicated by Prof. H. A. LORENTZ).

(Communicated in the meeting of June 24, 1916.)

Miss H. J. VAN LEEUWEN has recently published a paper containing some notes on DEBIJE's calculation of the dispersion formula of hydrogen, which calculation is founded on the well-known model of the H_2 -molecule¹⁾. In that paper it is demonstrated that some of the vibrations which occur in DEBIJE's calculations are unstable, and methods are discussed by which the stability of the model may be ensured.

¹⁾ These Proc (1916) Vol. XVIII, p. 1071.

One of these methods, viz. that of introducing as kinematical relation the condition that the moment of momentum of each electron must preserve the same value $\left(\frac{h}{2\pi}\right)$, is only touched upon in that paper¹⁾ and not fully worked out. It seems to me, however, that this may be done in the following way.

The equations expressing these conditions can be written as follows:

$$\left. \begin{aligned} mr_1^2 d\psi_1 &= \frac{h}{2\pi} dt \\ mr_2^2 d\psi_2 &= \frac{h}{2\pi} dt \end{aligned} \right\} \dots \dots \dots (1)$$

(*m*: mass of the electron;
r: radius of the orbit;
ψ: angle of position).

By their form they recall the equations between infinitesimal changes of the coordinates in a non-holonomic system; only *dt* also appears here. Now we may try to form the equations of motion in a way analogous to the treatment of non-holonomic systems by introducing into the formula of D'ALEMBERT'S principle auxiliary forces *Q_μ* which do not come into play in any virtual displacement. A virtual displacement will be defined as an arbitrary variation of the coordinates, subjected to the relations:

$$\left. \begin{aligned} mr_1^2 \delta\psi_1 &= 0 \\ mr_2^2 \delta\psi_2 &= 0 \end{aligned} \right\} \dots \dots \dots (2)$$

or:

$$\delta\psi_1 = \delta\psi_2 = 0,$$

which are derived from (1) by taking *δt* = 0. It appears that in a virtual displacement the *position angles* of the electrons must *not* be varied; from this it follows easily that only *tangential* auxiliary forces *Q₁* and *Q₂* may be introduced (i.e. forces which act upon the coordinates *ψ₁* and *ψ₂*), which have the task of ensuring the constancy of the moment of momentum.

Deduction of the equations of motion.
A. Free vibrations.

Notation. Distance of the nuclei: *2a* (this is regarded as a constant).

Radius of the orbit of the electrons in the normal state: *R*. (For *H₂*: *R* = *a*√3; *He*, to which the calculation likewise applies, has

¹⁾ l. c. p. 1081.

one nucleus at the centre with a double charge, hence for it $a = 0$)

Normal angular velocity: ω .

Distance of electron from centre of orbit: $r_i = R + \rho_i$ (measured parallel to the plane of the orbit).

Deviation of an electron normally to the plane of the orbit: z_i .

Angle of position: $\psi_i = \omega t + \vartheta_i$.

Furthermore we put.

$$W = \sqrt{R^2 + a^2}$$

$$\alpha = \rho_1 + \rho_2, \quad \gamma = z_1 + z_2, \quad \varphi = \vartheta_2 - \vartheta_1 - \pi.$$

$$\beta = \rho_1 - \rho_2, \quad \delta = z_1 - z_2$$

The quantities $\rho_1, \rho_2, z_1, z_2, \alpha, \beta, \gamma, \delta, \varphi$ are considered as infinitesimal, likewise $\dot{\rho}_1$, etc.

Between a, R, ω the relation exists.

$$mR\omega^2 = \frac{2e^2R}{W^3} - \frac{e^2}{4R^2} \dots \dots \dots (3)$$

which expresses the condition of equilibrium in the stationary state.

The kinetic energy is found to be:

$$T = \frac{1}{2}m(\dot{z}_1^2 + \dot{z}_2^2) + \frac{1}{2}m(\dot{\rho}_1^2 + \dot{\rho}_2^2) + \frac{1}{2}mR^2(\dot{\vartheta}_1^2 + \dot{\vartheta}_2^2) +$$

$$+ mR^2\omega(\vartheta_1 + \vartheta_2) + 2mR\omega(\rho_1\dot{\vartheta}_1 + \rho_2\dot{\vartheta}_2) + \frac{1}{2}m\omega^2(\rho_1^2 + \rho_2^2) +$$

$$+ mR\omega^2(\rho_1 + \rho_2) + mR^2\omega^2.$$

Potential Energy:

$$V = -\frac{4e^2}{W} + \frac{e^2}{2R} + \frac{2e^2R(\rho_1 + \rho_2)}{W^3} - \frac{e^2(\rho_1 + \rho_2)}{4R^2} + \frac{e^2(\rho_1 + \rho_2)^2}{8R^3} -$$

$$- \frac{e^2(z_1 - z_2)^2}{16R^3} - \frac{e^2}{W^6} [(2R^2 - a^2)(\rho_1^2 + \rho_2^2) - (R^2 - 2a^2)(z_1^2 + z_2^2)] +$$

$$+ \frac{e^2\varphi^2}{16R}.$$

(In both expressions terms of the 3rd and higher orders in the quantities ρ , etc. have been neglected).

D'ALEMBERT's principle gives the equations.

$$\frac{d}{dt} \left(\frac{\partial T}{\partial q_\mu} \right) - \frac{\partial T}{\partial q_\mu} + \frac{\partial V}{\partial q_\mu} - Q_\mu = 0.$$

(the Q_μ are the auxiliary forces mentioned above).

Hence we get:

$$\rho_1 - 2R\omega\dot{\vartheta}_1 - \omega^2\rho_1 = \frac{e^2}{m} \left[\frac{4R^2\rho_1 - 2a^2\rho_1}{W^6} - \frac{\rho_1 + \rho_2}{4R^3} \right] \dots \dots (4)$$

$$\rho_2 - 2R\omega\dot{\vartheta}_2 - \omega^2\rho_2 = \frac{e^2}{m} \left[\frac{4R^2\rho_2 - 2a^2\rho_2}{W^6} - \frac{\rho_1 + \rho_2}{4R^3} \right] \dots \dots (5)$$

$$R\dot{\vartheta}_1 + 2\omega\rho_1 = \frac{e^2\varphi}{8mR^2} + \frac{Q_1}{mR} \dots \dots \dots (6)$$

$$R\dot{\vartheta}_2 + 2\omega\dot{q}_2 = -\frac{e^2\varphi}{8mR^2} + \frac{Q_2}{mR} \dots (7)$$

$$z_1 = \frac{e^2}{m} \left[\frac{-2R^2 z_1 + 4a^2 z_1}{W^5} + \frac{z_1 - z_2}{8R^3} \right] \dots (8)$$

$$z_2 = \frac{e^2}{m} \left[\frac{-2R^2 z_2 + 4a^2 z_2}{W^5} - \frac{z_1 - z_2}{8R^3} \right] \dots (9)$$

(in deducing these, eq. (3) has already been used)

In addition to this, eqq. (1) give the relations.

$$m(R+q_1)^2 (\omega + \vartheta_1) = mR^2\omega \left(= \frac{h}{2\pi} \right)$$

$$m(R+q_2)^2 (\omega + \vartheta_2) = mR^2\omega \left(= \frac{h}{2\pi} \right)$$

After development, and with omission of terms of the 2nd and higher orders:

$$R\dot{\vartheta}_1 + 2q_1\omega = 0 \dots (10)$$

$$R\dot{\vartheta}_2 + 2q_2\omega = 0 \dots (11)$$

From eqq. (6), (7), (10) and (11) we get immediately.

$$Q_1 = -Q_2 = -\frac{e^2\varphi}{8R}$$

Further (4) and (5) can be simplified by means of (10) and (11) into.

$$q_1 + 3\omega^2 q_1 = \frac{e^2}{m} [\dots] \dots (4a)$$

$$q_2 + 3\omega^2 q_2 = \frac{e^2}{m} [\dots] \dots (5a)$$

Finally, by addition and subtraction of the foregoing equations:

$$\alpha + 3\omega^2\alpha = \alpha \cdot \frac{e^2}{m} \cdot \left[\frac{4R^2 - 2a^2}{W^5} - \frac{1}{2R^3} \right] \dots (12)$$

$$\beta + 3\omega^2\beta = \beta \cdot \frac{e^2}{m} \cdot \frac{4R^2 - 2a^2}{W^5} \dots (13)$$

$$\gamma = \gamma \cdot \frac{e^2}{m} \cdot \frac{-2R^2 + 4a^2}{W^5} \dots (14)$$

$$\delta = \delta \cdot \frac{e^2}{m} \cdot \left[\frac{-2R^2 + 4a^2}{W^5} + \frac{1}{4R^3} \right] \dots (15)$$

Result for *Hydrogen*.

$$\ddot{\alpha} + 1.9288 \omega^2 \alpha = 0 \dots (I)$$

$$\ddot{\beta} + 1.4522 \omega^2 \beta = 0 \dots (II)$$

$$\ddot{\gamma} + 0.3096 \omega^2 \gamma = 0 \dots (III)$$

$$\ddot{\delta} + 0.0713 \omega^2 \delta = 0 \dots (IV)$$

If α and β , and thus ϱ_1 and ϱ_2 are solved from (I) and (II), eqq. (10) and (11) give ϑ_1 and ϑ_2 .

It appears from equations (I)–(IV) that we get 4 *stable* modes of vibration; the unstable vibration D_2 and the indifferent one C_1 , which Miss v. LEEUWEN gave (l. c. p. 1074) have disappeared.

Besides some of the frequencies have changed a little.

Helium:

$$\ddot{\alpha} + \omega^2 \alpha = 0 \dots\dots\dots (I)$$

$$\ddot{\beta} + \frac{5}{7} \omega^2 \beta = 0 \dots\dots\dots (II)$$

$$\ddot{\gamma} + \frac{8}{7} \omega^2 \gamma = 0 \dots\dots\dots (III)$$

$$\ddot{\delta} + \omega^2 \delta = 0 \dots\dots\dots (IV)$$

(N.B. In the He-atom the plane of the orbit of the electrons can turn freely about the nucleus; hence the δ -motion is here not a true vibration).

Note.

As the coordinates ψ_1 and ψ_2 do not appear themselves in T , we might, in deducing the equations of motion, treat them as cyclic coordinates, eliminating $\dot{\psi}_i$ ($= \omega + \dot{\vartheta}_i$) by means of

$$\dot{\psi}_i = \frac{h}{2\pi m r_i^2}$$

and forming the kinetic potential according to ROUTH and HELMHOLTZ.

This method of eliminating the $\dot{\psi}_i$ is used by L. FÖPPL in an investigation on the stability of BOHR's model¹⁾. If we applied it here, the term

$$\frac{e^2 \varphi^2}{16R} = \frac{e^2 (\psi_2 - \psi_1 - \pi)^2}{16R}$$

would remain in V , so that we should be obliged to omit it altogether, whereas in the calculation given above its influence is annihilated by the forces Q_1 and Q_2 .

B. Forced vibrations. — Dispersion formula.

The course of the following calculation is for the greater part the same as that followed by DEBIJE²⁾.

We will make use of two systems of coordinates: One system is invariably attached to the molecule, the axis of z is laid along the line which joins the nuclei; the axis of x along the line which joins the electrons; the axis of y perpendicularly to the latter in

¹⁾ Phys. Z. S. 15 (1914) S. 707.

²⁾ Sitz. Ber. Bayr. Akad. 1915, S. 1.

the plane of the orbit. The other one (the $x'y'z'$ -system) is fixed in space, and coincides with the former for $t = 0$.

Let the incident electric vibration be $E \cdot e^{ist}$, its components along $x'y'z'$ -axes :

$$P \cdot e^{ist}, \quad Q e^{ist}, \quad R e^{ist};$$

where :

$$P = E \cos \alpha, \quad Q = E \cos \beta, \quad R = E \cos \gamma$$

Putting

$$\begin{aligned} P + i Q &= p, \\ P - i Q &= q, \end{aligned}$$

we find for the components along the rotating axes :

$$\left. \begin{aligned} X &= \frac{1}{2} p e^{i(s-\omega)t} + \frac{1}{2} q e^{i(s+\omega)t} \\ Y &= -\frac{i}{2} p e^{i(s-\omega)t} + \frac{i}{2} q e^{i(s+\omega)t} \\ Z &= R e^{ist} \end{aligned} \right\} \dots \dots \dots (16)$$

The equations for the forced vibrations can be deduced from (4)–(9) by adding to the members on the right hand side :

$$-\frac{Xe}{m}, \quad +\frac{Xe}{m}, \quad -\frac{Ye}{mR}, \quad \text{etc.}$$

As only the β -vibration with the φ -vibration (which is coupled to the former by the equations (10) and (11), to which we adhere in this calculation too), and the γ -motion give an electric moment, we obtain, denoting the frequencies of the free β - and γ -motion by n_1 and n_2 :

$$\beta + n_1^2 \beta = -\frac{2Xe}{m} \dots \dots \dots (17)$$

$$\gamma + n_2^2 \gamma = -\frac{2Ze}{m} \dots \dots \dots (18)$$

$$R\varphi - 2\omega\beta = 0 \dots \dots \dots (19)$$

Eq. (19) is deduced by subtracting eq. (10) from eq. (11). The auxiliary forces Q_1 , and Q_2 have now different values, as they have also to annihilate the Y -component of the incident electric vibration.

The components of the electric moment are found to be :

$$\left. \begin{aligned} M_x &= -e\beta = \frac{e^2}{m} \left[\frac{p e^{i(s-\omega)t}}{n_1^2 - (s-\omega)^2} + \frac{q e^{i(s+\omega)t}}{n_1^2 - (s+\omega)^2} \right] \\ M_y &= Re\varphi = 2i \frac{e^2}{m} \left\{ \frac{p \frac{\omega}{s-\omega} e^{i(s-\omega)t}}{n_1^2 - (s-\omega)^2} + \frac{q \frac{\omega}{s+\omega} e^{i(s+\omega)t}}{n_1^2 - (s+\omega)^2} \right\} \\ M_z &= -e\gamma = 2 \frac{e^2}{m} \frac{R e^{ist}}{n_2^2 - s^2} \end{aligned} \right\} \dots \dots \dots (20)$$

From these quantities we must derive the components along the fixed system of axes :

$$M_x' = M_x \cos \omega t - M_y \sin \omega t = \\ = e^{ist} \cdot \frac{e^2}{m} \left[p \cdot \frac{(\omega-s) + (\omega+s) i \sin \omega t e^{-i\omega t}}{(\omega-s)[n_1^2 - (\omega-s)^2]} + q \cdot \frac{(\omega+s) - (\omega-s) i \sin \omega t e^{i\omega t}}{(\omega+s)[n_1^2 - (\omega+s)^2]} \right]$$

Part of the function between the [] is independent of t , part of it depends periodically on t with frequency ω . As ω has nothing to do with s (usually ω is much greater than s) we can take the mean of this part with respect to the time¹⁾; the formula then reduces to:

$$M_x' = e^{ist} \cdot \frac{e^2}{m} \left[\frac{\frac{3\omega-s}{2} \cdot p}{(\omega-s)[n_1^2 - (\omega-s)^2]} + \frac{\frac{3\omega+s}{2} \cdot q}{(\omega+s)[n_1^2 - (\omega+s)^2]} \right]$$

In the same way we find:

$$M_y' = e^{ist} \cdot \frac{e^2}{m} \left[\frac{-\frac{3\omega-s}{2} \cdot ip}{(\omega-s)[n_1^2 - (\omega-s)^2]} + \frac{\frac{3\omega+s}{2} \cdot iq}{(\omega+s)[n_1^2 - (\omega+s)^2]} \right] \quad (21)$$

Finally:

$$M_z' = e^{ist} \cdot \frac{e^2}{m} \frac{2R}{n_2^2 - s^2}$$

Resulting moment in the direction of E :

$$M = M_x' \cdot \cos \alpha + M_y' \cdot \cos \beta + M_z' \cos \gamma = \\ = e^{ist} \cdot \frac{Ee^2}{m} \left[\frac{\frac{3\omega-s}{2} (\cos^2 \alpha + \cos^2 \beta)}{(\omega-s)[n_1^2 - (\omega-s)^2]} + \frac{\frac{3\omega+s}{2} (\cos^2 \alpha + \cos^2 \beta)}{(\omega+s)[n_1^2 - (\omega+s)^2]} + \frac{2 \cos^2 \gamma}{n_2^2 - s^2} \right]$$

The mean of this quantity for all possible directions of the $x'y'z'$ system is:

$$\overline{M} = e^{ist} \cdot \frac{Ee^2}{3m} \left[\frac{3\omega-s}{(\omega-s)[n_1^2 - (\omega-s)^2]} + \frac{3\omega+s}{(\omega+s)[n_1^2 - (\omega+s)^2]} + \frac{2}{n_2^2 - s^2} \right] \quad (22)$$

(as:

$$\overline{\cos^2 \alpha} = \overline{\cos^2 \beta} = \overline{\cos^2 \gamma} = \frac{1}{3})$$

For the index of refraction we have the formula:

$$n^2 - 1 = 4\pi \frac{N_1 \cdot \overline{M}}{E \cdot e^{ist}}$$

(N_1 : number of molecules per cc.)

Hence:

$$n^2 - 1 = \frac{4\pi N_1 e^2}{3m} \left[\frac{3\omega-s}{(\omega-s)[n_1^2 - (\omega-s)^2]} + \frac{3\omega+s}{(\omega+s)[n_1^2 - (\omega+s)^2]} + \frac{2}{n_2^2 - s^2} \right] \quad (23)$$

¹⁾ DEBIJE (l. c. S. 15) expresses this in a somewhat different way: in his formulae the axes of x and x' make the angle α for $t=0$, hence he has everywhere $\omega t + \alpha$ instead of ωt . Then the mean is taken for all values of the phase-angle α , which gives the same result.

As s is small as compared to ω , we may develop according to powers of $\frac{s}{\omega}$; this gives, when s^4, \dots is neglected:

$$n^2 - 1 = \frac{4\pi N_1 e^2}{3m} \left[\frac{6}{n_1^2 - \omega^2} + \frac{2}{n_2^2} + s^2 \left(\frac{4}{\omega^2(n_1^2 - \omega^2)} - \frac{2}{(n_1^2 - \omega^2)^2} + \frac{24\omega^2}{(n_1^2 - \omega^2)^3} + \frac{2}{n_2^4} \right) \right] \quad (24)$$

Hydrogen.

From eqq. (II) and (III) we get:

$$n_1^2 = 1.4522 \omega^2; \quad n_2^2 = 0.3096 \omega^2.$$

hence:

$$n - 1 = \frac{2\pi N_1 e^2}{3m \omega^2} \left(19.73 + 280.4 \frac{s^2}{\omega^2} \right)$$

If we introduce the values:

$$N_1 = \frac{6.15 \times 10^{23}}{22400}; \quad \frac{e}{m} = 5.31 \times 10^{17}; \quad e = 4.78 \times 10^{-10};$$

$$h = 6.415 \times 10^{-27};$$

formula (3) in connection with

$$mR^2\omega = \frac{h}{2\pi}$$

gives

$$\omega = 4.856 \times 10^{16};$$

further:

$$\frac{2\pi N_1 e^2}{3m} = 1.461 \times 10^{28}$$

Thus the dispersion formula becomes:

$$n - 1 = 1.22 \times 10^{-4} + 7.35 \times 10^{-37} s^2 \quad (25)$$

DEBIJE's formula:¹⁾

$$n - 1 = \frac{2\pi N_1 e^2}{3\omega^2} \left(19.26 + 75.3 \frac{s^2}{\omega^2} \right)$$

gives with the same values:

$$n - 1 = 1.193 \times 10^{-4} + 1.98 \times 10^{-37} s^2.$$

The experimental formulae are (cf. DEBIJE, l.c. pag. 20, 22), that of J. KOCH:

$$n - 1 = 1.361 \times 10^{-4} + 2.908 \times 10^{-37} s^2$$

and that of C. and M. CUTHBERTSON:

$$n - 1 = 1.362 \times 10^{-4} + 2.780 \times 10^{-37} s^2.$$

In formula (25) the coefficient of s^2 appears to be *much too large*. Partly this is due to the frequency n_1 of the β -vibration, which is *smaller* than the value of the corresponding frequency in DEBIJE's

¹⁾ l. c. p. 20.

calculation, this makes one of the resonance frequencies lie much nearer to the visible spectrum.

We have found:

$$n_1 = 1.205 \omega$$

while in the original model:

$$n_1 = 1.412 \omega$$

(cf. the paper by Miss H. J. v. LEEUWEN. p. 1074).

Resonance occurs if the incident wave motion has one of the values:

$$s_1 = n_1 + \omega = 2.205 \omega$$

$$s_2 = n_1 - \omega = 0.205 \omega$$

$$s_3 = n_2 = 0.556 \omega$$

λ_2 is the smallest; to it corresponds a wave-length of about 1890 Å units).

Helium.

For Helium: $n_1^2 = \frac{5}{7} \omega^2 = 0.7143 \omega^2$, and so $n_1^2 - \omega^2 < 0$. Hence in formula (25) the principal terms become negative, and for values of s not too high

$$n < 1.$$

This is in contradiction with the experimental values. (Cf. C. and M. CUTHBERTSON, Proc. Roy. Soc. (A) LXXXIV, p. 13).

SUMMARY.

1. In continuation of the investigation by Miss H. J. VAN LEEUWEN on the instability of BOHR and DEBIJÉ's model of the hydrogen molecule, a new hypothesis is examined by which the system may be made stable.

2. The model made stable in this way gives neither for H_2 , nor for He a dispersion formula which agrees with the formula experimentally found.

Note added in the English translation

Since this was written a paper has appeared by C. DAVISSON on the *Dispersion of Hydrogen and Helium* (Phys. Rev. (22) VIII, p. 20, July 1916).

Mr. DAVISSON uses the same method to ensure the stability of the model, but he arrives at a somewhat different formula (it seems to me that he overlooks the influence of the conditions (10) and (11) and of the auxiliary forces Q_1 and Q_2 necessitated by them on the -vibration). As Mr. DAVISSON points out himself, his formula too gives for both gases results which are in conflict with the experimental ones.

Mathematics. — “On the values which the function $\zeta(s)$ assumes for s positive and odd.” By J. G. VAN DER CORPUT. (Communicated by Prof. J. C. KLUYVER).

(Communicated in the meeting of February 26, 1916)

This article is intended to deduce some formulae that may be used to calculate $\zeta(s)$ for odd values of the argumentum $s > 1$; for this purpose we will express these ζ functions in the quantities $I_1(m, n)$, $I_2(m, n)$ and $I(n, \alpha)$, which have the following significance:

$$I_1(m, n) = \pi \int_0^1 y^m (1-y)^n \cotg \pi y \, dy =$$

$$= n! \left(\frac{1}{m(m+1)\dots(m+n)} - \sum_1^{\infty} \frac{B_r \pi^{2r}}{(2r)!(2r+m)(2r+m+1)\dots(2r+m+n)} \right)$$

for m and n integer and positive,

$$I_2(m, n) = \frac{\pi}{2} \int_0^1 y^m (1-y)^n \cotg \frac{\pi y}{2} \, dy =$$

$$= n! \left(\frac{1}{m(m+1)\dots(m+n)} - \sum_1^{\infty} \frac{B_r \left(\frac{\pi}{2}\right)^{2r}}{(2r)!(2r+m)(2r+m+1)\dots(2r+m+n)} \right)$$

for m and n integer, $m > 0$ and $n \geq 0$,

$$I(n, \alpha) = \int_0^1 (1-y)^n \left(\frac{1}{y} - \pi \alpha \cotg \pi \alpha y \right) dy = n! \sum_1^{\infty} \frac{B_r (\alpha \pi)^{2r}}{(2r) \cdot (2r+n)!}$$

for $1 > \alpha > 0$, and n integer ≥ 0 and also for $\alpha = 1$ and n integer > 0 .

In order to connect the ζ function with the quantities $I_1(m, n)$, $I_2(m, n)$ and $I(n, \alpha)$ we will use the method indicated by Professor Dr. J. C. KLUYVER in the article: “Sur les valeurs que prend la fonction $\zeta(s)$ de RIEMANN pour s entier positif et impair”. (Bulletin des Sciences Mathématiques, 1896).

If $f(y)$ represents a polynomium in y , which becomes zero for $y = 0$ and for $y = 1$, the uniform function

$$\frac{f\left(\frac{z}{2\pi i}\right)}{e^z - 1}$$

is holomorphous in the domain of the rectangle bounded by the lines $x = 0$, $y = 0$, $x = \beta$, $y = 2\pi$. By applying the theorem of CAUCHY and then putting $\beta = \infty$, we therefore find the relation

$$\int_0^{\infty} \frac{f\left(\frac{z}{2\pi i}\right) - f\left(\frac{z}{2\pi i} + 1\right)}{e^z - 1} dz = -\pi i \int_0^1 f(y) dy + \pi \int_0^1 f(y) \cotg \pi y dy \quad (1)$$

By writing in this formula $f(y) = y^m (1-y)^n$, we conclude

$$\int_0^1 \frac{\left(\frac{z}{2\pi i}\right)^m \left(1 - \frac{z}{2\pi i}\right)^n + (-1)^{n+1} \left(\frac{z}{2\pi i}\right)^n \left(1 + \frac{z}{2\pi i}\right)^m}{e^z - 1} dz =$$

$$= -\frac{\pi m! n!}{(m+n+1)!} + I_1(m, n)$$

for m and n integer and positive and by giving definite values to m and n , in this relation we find for $\zeta(3)$

$$\zeta(3) = -\frac{2\pi^2}{3} I_1(2, 1) = \frac{2\pi^2}{3} I_1(1, 2) = -\frac{2\pi^2}{3} I_1(3, 1) = \frac{2\pi^2}{3} I_1(1, 3).$$

If, however, $f(y)$ represents a polynomium in y , which disappears for $y = 1$, but not for $y = 0$, formula (1) will hold good if $f(y)$ is replaced by $f(y) - (1-y)f(0)$; this produces

$$\int_0^{\infty} \frac{f\left(\frac{z}{2\pi i}\right) - f\left(\frac{z}{2\pi i} + 1\right) - f(0)}{e^z - 1} dz =$$

$$= -\pi i \int_0^1 \{f(y) - (1-y)f(0)\} dy + \pi \int_0^1 \{f(y) - (1-y)f(0)\} \cotg \pi y dy$$

$$= -\pi i \int_0^1 f(y) dy + \frac{1}{2} \pi i f(0) - \int_0^1 f(y) \left(\frac{1}{y} - \pi \cotg \pi y\right) dy +$$

$$+ \int_0^1 \frac{f(y) - f(0)}{y} dy - f(0) \int_0^1 (1-y) \left(\pi \cotg \pi y - \frac{1}{y}\right) dy + \int_0^1 f(0) dy$$

$$= -\pi i \int_0^1 f(y) dy + \frac{1}{2} \pi i f(0) - \int_0^1 f(y) \left(\frac{1}{y} - \pi \cotg \pi y\right) dy + \int_0^1 \frac{f(y) - f(0)}{y} dy + f(0) \log 2\pi.$$

The particular case $f(y) = (1-y)^n$ produces the formula

$$\int_0^{\infty} \frac{1 + \left(\frac{zi}{2\pi}\right)^n - \left(1 + \frac{zi}{2\pi}\right)^n}{e^z - 1} dz = \frac{\pi i}{n+1} - \frac{\pi i}{2} + I(n, 1) + \sum_{k=1}^n \frac{1}{k} - \log 2\pi,$$

i.e. for $n = 3$:

$$\zeta(3) = \frac{2\pi^2}{3} \left(\frac{11}{6} - \log 2\pi + I(3, 1)\right)$$

If we reduce the height of the rectangle to half its original height and so take it equal to π , we find in the same way as in which (1) has been deduced, supposing $f(z)$ is a polynomial in y disappearing for $y = 0$,

$$\int_0^{\infty} \frac{f\left(\frac{z}{\pi i}\right)}{e^z - 1} dz + \int_0^{\infty} \frac{f\left(\frac{z}{\pi i} + 1\right)}{e^z + 1} dz = -\frac{\pi i}{2} \int_0^1 f(y) dy + \frac{\pi}{2} \int_0^1 f(y) \cotg \frac{\pi y}{2} dy$$

and as:

$$\begin{aligned} \int_0^{\infty} \frac{f\left(\frac{z}{\pi i} + 1\right)}{e^z + 1} dz &= f(1) \int_0^{\infty} \frac{dz}{e^z + 1} + \int_0^{\infty} \frac{f\left(\frac{z}{\pi i} + 1\right) - f(1)}{e^z + 1} dz \\ &= f(1) \log 2 + \int_0^{\infty} \left\{ f\left(\frac{z}{\pi i} + 1\right) - f(1) \right\} \left\{ \frac{1}{e^z - 1} - \frac{2}{e^{2z} - 1} \right\} dz = \\ &= f(1) \log 2 + \int_0^{\infty} \frac{f\left(\frac{z}{\pi i} + 1\right) - f\left(\frac{z}{2\pi i} + 1\right)}{e^z - 1} dz \end{aligned}$$

at last:

$$\begin{aligned} \int_0^{\infty} \frac{f\left(\frac{z}{\pi i}\right) + f\left(\frac{z}{\pi i} + 1\right) - f\left(\frac{z}{2\pi i} + 1\right)}{e^z - 1} dz = \\ = -\frac{\pi i}{2} \int_0^1 f(y) dy - f(1) \log 2 + \frac{\pi}{2} \int_0^1 f(y) \cotg \frac{\pi y}{2} dy \quad (2) \end{aligned}$$

The substitution $f(y) = y^m (1-y)^n$ produces the relations

$$\begin{aligned} \int_0^{\infty} \frac{\left(-\frac{zi}{\pi}\right)^m \left(1 + \frac{zi}{\pi}\right)^n + \left(\frac{zi}{\pi}\right)^n \left(1 - \frac{zi}{\pi}\right)^m - \left(\frac{zi}{2\pi}\right)^n \left(1 - \frac{zi}{2\pi}\right)^m}{e^z - 1} dz \\ = -\frac{\pi i m! n!}{2(m+n+1)!} + I_2(m, n) \end{aligned}$$

for m and n integer and positive and

$$\int_0^{\infty} \frac{\left(\frac{zi}{\pi}\right)^m + \left(1 + \frac{zi}{\pi}\right)^m - \left(1 + \frac{zi}{2\pi}\right)^m}{e^z - 1} dz = \frac{\pi i}{2(m+1)} - \log 2 + I_2(m, 0)$$

for m integer and positive and consequently in particular

$$\zeta(3) = \frac{2\pi^2}{7} I_2(1, 1) = \frac{2\pi^2}{5} I_2(1, 2) = \pi^2 I_2(2, 1) = \frac{2\pi^2}{7} (\log 2 - I_2(2, 0)).$$

If $f(0) \neq 0$, we replace in (2) $f(y)$ by the polynomium $f(y) - f(0)$ which leads to

$$\begin{aligned} & \int_0^{\infty} \frac{f\left(\frac{z}{\pi i}\right) + f\left(\frac{z}{\pi i} + 1\right) - f\left(\frac{z}{2\pi i} + 1\right) - f(0)}{e^z - 1} dz = \\ &= -\frac{\pi i}{2} \int_0^1 f(y) dy + \frac{\pi i f(0)}{2} - (f(1) - f(0)) \log 2 + \\ & \quad + f(0) \int_0^1 \left(\frac{1}{y} - \frac{\pi}{2} \cotg \frac{\pi y}{2}\right) dy + \int_0^1 \frac{f(y) - f(0)}{y} dy - \int_0^1 f(y) \left(\frac{1}{y} - \frac{\pi}{2} \cotg \frac{\pi y}{2}\right) dy \\ &= -\frac{\pi i}{2} \int_0^1 f(y) dy + \frac{1}{2} \pi i f(0) - f(1) \log 2 + f(0) \log \pi + \\ & \quad + \int_0^1 \frac{f(y) - f(0)}{y} dy - \int_0^1 f(y) \left(\frac{1}{y} - \frac{\pi}{2} \cotg \frac{\pi y}{2}\right) dy \end{aligned}$$

and, in consequence for $f(y) = (1 - y)^n$, in which n represents an integer positive number,

$$\int_0^{\infty} \frac{\left(1 + \frac{z}{\pi}\right)^n + \left(1 - \frac{1}{2^n}\right) \left(\frac{z}{\pi}\right)^n - 1}{e^z - 1} dz = -\frac{\pi i}{2(n+1)} + \frac{\pi i}{2} + \log \pi - \sum_{k=1}^n \frac{1}{k} - I(n, \frac{1}{2}).$$

This formula contains the relation

$$\zeta(3) = \frac{2\pi^2}{7} \left(\frac{3}{2} - \log \pi + I(2, \frac{1}{2})\right)$$

particularly. If we now choose the height of the rectangle $2a\pi$ in which $1 > a > 0$, the method already followed twice before, produces the relation

$$\int_0^{\infty} \frac{f\left(\frac{z}{2\pi i a}\right)}{e^z - 1} dz - \int_0^{\infty} \frac{f\left(\frac{z}{2\pi i a} + 1\right)}{e^{z+2\pi i a} - 1} dz = -\pi i a \int_0^1 f(y) dy + \pi i \int_0^1 f(y) \cotg \pi a y dy,$$

if $f(y)$ represents a polynomium in y and $f(0) = 0$; if however $f(0)$ does not disappear, we arrive, by replacing $f(y)$ in this relation by $f(y) - f(0)$, at the formula

$$\begin{aligned} & \int_0^\infty \frac{f\left(\frac{z}{2\pi i a}\right) - f(0)}{e^z - 1} dz - \int_0^\infty \frac{f\left(\frac{z}{2\pi i a} + 1\right)}{e^{z+2\pi i} - 1} dz = \\ &= -f(0) \int_0^1 \frac{dz}{e^{z+2\pi i} - 1} + f(0) \int_0^1 \left(\frac{1}{y} - \pi a \cot \pi a y\right) dy - \pi i a \int_0^1 (f(y) - f(0)) dy + \\ & \quad + \int_0^1 \frac{f(y) - f(0)}{y} dy - \int_0^1 f(y) \left(\frac{1}{y} - \pi a \cot \pi a y\right) dy \\ &= f(0) \log 2\pi a + \frac{1}{2} \pi i f(0) - \pi i a \int_0^1 f(y) dy + \int_0^1 \frac{f(y) - f(0)}{y} dy - \\ & \quad - \int_0^1 f(y) \left(\frac{1}{y} - \pi a \cot \pi a y\right) dy. \end{aligned}$$

As for n integer and positive

$$\frac{1}{(n-1)!} \int_0^\infty \frac{z^{n-1} dz}{e^{z+2\pi i} - 1} = \sum_{\nu=1}^\infty \frac{\cos 2\nu\pi a}{\nu^n} - i \sum_{\nu=1}^\infty \frac{\sin 2\nu\pi a}{\nu^n}$$

many relations containing the series $\sum_1^\infty \frac{\cos 2\nu\pi a}{\nu^n}$ and $\sum_1^\infty \frac{\sin 2\nu\pi a}{\nu^n}$ are to be deduced from this formula. But we will restrict ourselves to the ζ -function and therefore write $f(y) = (1-y)^{2n}$, in which n represents an integer positive number; if the real part of a complex number γ is indicated by $R(\gamma)$ it ensues from what preceded that

$$\begin{aligned} & \int_0^\infty \frac{R\left(1 + \frac{zi}{2\pi a}\right)^{2n} - 1}{e^z - 1} dz + \frac{(-1)^{n+1}}{(2\pi a)^{2n}} \int_0^\infty z^{2n} R\left(\frac{1}{e^{z+2\pi i} - 1}\right) dz \\ &= \log 2\pi a - \sum_1^{2n} \frac{1}{\nu} - I(2n, a) \dots \dots \dots (3) \end{aligned}$$

In order to find relations for the ζ -function by means of this formula, the following auxiliary proposition may be used:

If a represents an integer number > 2 and q describes half the reduced rest system, modulo a , between 0 and a , and that in such a way that the series of the numbers, of which the values are successively assumed by q , does not contain two numbers, the sum of which is equal to a , then:

$$\sum_{\rho} R\left(\frac{1}{e^{z+\frac{2\pi i \rho}{a}} - 1}\right) = \frac{1}{2} \sum_{d|a} \frac{\mu\left(\frac{a}{d}\right) d}{e^{dz} - 1}.$$

The proof of this auxiliary proposition is simple; for if, in the second member of the relation

$$\sum_{d|a} \frac{\mu\left(\frac{a}{d}\right) d}{e^{dz} - 1} = \sum_{d|a} \mu\left(\frac{a}{d}\right) \sum_{d_1=1}^d \frac{1}{e^{z+\frac{2\pi i d_1}{d}} - 1}$$

$a = dd_2$ and $d_1 d_2 = d$, and consequently $\frac{d_1}{d} = \frac{d_1 d_2}{dd_2} = \frac{d_2}{a}$ is written, so that d_2 is a divisor of the greatest common divisor (a, d_2) of a and d_2 , the relation takes this shape,

$$\sum_{d|a} \frac{\mu\left(\frac{a}{d}\right) d}{e^{dz} - 1} = \sum_{d_2=1}^a \frac{1}{e^{z+\frac{2\pi i d_2}{a}} - 1} \sum_{d_1|(\frac{a}{d_2})} \mu(d_1) = \sum_{\lambda} \frac{1}{e^{z+\frac{2\pi i \lambda}{a}} - 1},$$

in which λ describes the reduced rest system, modulo a , between 0 and a , and so

$$\frac{1}{2} \sum_{d|a} \frac{\mu\left(\frac{a}{d}\right) d}{e^{dz} - 1} = \frac{1}{2} \sum_{\rho} \left(\frac{1}{e^{z+\frac{2\pi i \rho}{a}} - 1} + \frac{1}{e^{z+\frac{2\pi i (\rho-\rho)}{a}} - 1} \right) = \sum_{\rho} R\left(\frac{1}{e^{z+\frac{2\pi i \rho}{a}} - 1}\right),$$

with which the auxiliary proposition has been proved.

From this proposition follows for $n > 0$

$$\sum_{\rho} \int_0^{\infty} z^{2n} R\left(\frac{1}{e^{z+\frac{2\pi i \rho}{a}} - 1}\right) dz = \frac{1}{2} \sum_{d_1|a} \mu\left(\frac{a}{d_1}\right) d_1 \int_0^{\infty} \frac{z^{2n} dz}{e^{d_1 z} - 1} = \frac{(2n)! \zeta(2n+1) \sum_{d|a} \mu(d) d^{2n}}{2 \cdot a^{2n}}$$

Replace in (3) a by $\frac{\mu}{a}$ multiply then both members by q^{2n} and add further all relations, which are acquired in this way by making q assume the values mentioned before; the result is then

$$\left. \begin{aligned} \sum_{\rho} \int_0^{\infty} \frac{R\left(q + \frac{az i}{2\pi}\right)^{2n} - q^{2n}}{e^z - 1} dz + \frac{(-1)^{n+1} (2n)!}{2 \cdot (2\pi)^{2n}} \zeta(2n+1) \sum_{d|a} \mu(d) d^{2n} \\ = \sum_{\rho} q^{2n} \left\{ \log \frac{2\pi q}{a} - \sum_{\chi=1}^{2n} \frac{1}{\chi} - I\left(2n, \frac{q}{a}\right) \right\} \end{aligned} \right\} \quad (4)$$

and consequently for $n = 1$

$$(2a^3 - \sum_{d|a} \mu(d) d^2) \zeta(3) = 4\pi^2 \sum_{\rho} \rho^2 \left(\frac{3}{2} - \log \frac{2\pi\rho}{a} + I\left(2, \frac{\rho}{a}\right) \right).$$

By supposing a to be respectively equal to 3, 4 and 6, we find particularly:

$$\begin{aligned} \zeta(3) &= \frac{2\pi^2}{13} \left(\frac{3}{2} - \log \frac{2\pi}{3} + I\left(2, \frac{1}{3}\right) \right) = \frac{8\pi^2}{13} \left(\frac{3}{2} - \log \frac{4\pi}{3} + I\left(2, \frac{2}{3}\right) \right) \\ &= \frac{4\pi^2}{47} \left(\frac{3}{2} - \log \frac{\pi}{2} + I\left(2, \frac{1}{4}\right) \right) = \frac{36\pi^2}{47} \left(\frac{3}{2} - \log \frac{3\pi}{4} + I\left(2, \frac{3}{4}\right) \right) \\ &= \frac{\pi^2}{12} \left(\frac{3}{2} - \log \frac{\pi}{3} + I\left(2, \frac{1}{6}\right) \right) = \frac{25\pi^2}{12} \left(\frac{3}{2} - \log \frac{5\pi}{6} + I\left(2, \frac{5}{6}\right) \right). \end{aligned}$$

It is evident that the relations found also produce many formulae for the calculation of $\zeta(5)$, $\zeta(7)$, ... etc.; this we will work out further for the case that the terms of the series acquired, diminish quickest; this happens by writing in (4) $a = 6$ and $\mu = 1$, by means of which the relation

$$\begin{aligned} \int_0^{\infty} \frac{\Re\left(1 + \frac{6z^i}{2\pi}\right)^{2n} - 1}{e^z - 1} dz + \frac{(-1)^{n+1}(2n)!}{2 \cdot (2\pi)^{2n}} (6^{2n} - 3^{2n} - 2^{2n} + 1) \zeta(2n+1) \\ = \log \frac{\pi}{3} - \sum_1^{2n} \frac{1}{z} - I\left(2n, \frac{1}{6}\right) \end{aligned}$$

is found, i.e.

$$\begin{aligned} \frac{6^{2n} + 3^{2n} + 2^{2n} - 1}{2 \cdot (2\pi)^{2n}} \zeta(2n+1) &= \sum^{n-1} (-1)^{n-1-i} \left(\frac{3}{\pi}\right)^{2i} \frac{\zeta(2i+1)}{(2n-2i)!} + \\ &+ \frac{(-1)^{n+1}}{(2n)!} \left(\sum_1^{2n} \frac{1}{z} - \log \frac{\pi}{3} + I\left(2n, \frac{1}{6}\right) \right), \end{aligned}$$

consequently

$$\begin{aligned} \zeta(3) &= \frac{\pi^2}{12} \left(\frac{1}{2} - \log \frac{\pi}{3} + I\left(2, \frac{1}{6}\right) \right), \\ 29 \zeta(5) &= 3\pi^2 \zeta(3) - \frac{\pi^4}{36} \left(\frac{25}{12} - \log \frac{\pi}{3} + I\left(4, \frac{1}{6}\right) \right), \\ 659 \zeta(7) &= 72 \pi^2 \zeta(5) - \frac{2\pi^4}{3} \zeta(3) + \frac{\pi^6}{5 \cdot 3^4} \left(\frac{75}{20} - \log \frac{\pi}{3} + I\left(6, \frac{1}{6}\right) \right), \dots \text{ etc.} \end{aligned}$$

The quantity $I\left(2n, \frac{1}{6}\right)$ occurring in this formula may be determined from its definition

$$I\left(2n, \frac{1}{6}\right) = \int_0^1 (1-y)^{2n} \left(\frac{1}{y} - \frac{\pi}{6} \cotg \frac{\pi y}{6} \right) dy = (2n)! \sum_{r=1}^{\infty} \frac{B_r \left(\frac{\pi}{6}\right)^{2r}}{(2r) \cdot (2r+2n)!}$$

but also by means of other series of which the terms diminish more quickly, for, if q represents an arbitrary integer positive number,

$$\begin{aligned} \frac{1}{y} - \frac{\pi}{6} \cot g \frac{\pi y}{6} &= \frac{2}{y} \sum_{\rho=1}^{\infty} \left(\frac{y}{6}\right)^{2\rho} \zeta(2\rho) = \\ &= \frac{2}{y} \sum_{\rho=1}^{\infty} \left(\frac{y}{6}\right)^{2\rho} \left\{ \zeta(2\rho) - \sum_{\nu=1}^q \frac{1}{\nu^{2\rho}} \right\} + \frac{2}{y} \sum_{\rho=1}^q \sum_{\nu=1}^{\infty} \left(\frac{y}{6\nu}\right)^{2\rho} \\ &= \frac{2}{y} \sum_{\rho=1}^q \left(\frac{y}{6}\right)^{2\rho} \left\{ \zeta(2\rho) - \sum_{\nu=1}^q \frac{1}{\nu^{2\rho}} \right\} + \sum_{\nu=1}^q \frac{1}{6\nu - y} - \sum_{\nu=1}^q \frac{1}{6\nu + y} \end{aligned}$$

and therefore

$$\begin{aligned} I(2n, \frac{1}{6}) &= 2 \int_0^1 (1-y)^{2n} \sum_{\rho=1}^{\infty} \frac{y^{2\rho-1}}{6^{2\rho}} \left\{ \zeta(2\rho) - \sum_{\nu=1}^q \frac{1}{\nu^{2\rho}} \right\} dy + \\ &+ \sum_{\nu=1}^q \int_0^1 \frac{(1-y)^{2n}}{6\nu - y} dy - \sum_{\nu=1}^q \int_0^1 \frac{(1-y)^{2n}}{6\nu + y} dy \end{aligned}$$

Now is

$$\begin{aligned} \int_0^1 \frac{(1-y)^{2n}}{6\nu - y} dy &= \int_0^1 \frac{(6\nu - 1)^{2n}}{6\nu - y} dy - \int_0^1 \frac{(6\nu - 1)^{2n} - (1-y)^{2n}}{(6\nu - 1) + (1-y)} dy = \\ &= - (6\nu - 1)^{2n} \log \left(1 - \frac{1}{6\nu} \right) + \sum_{\rho=1}^{2n} (-1)^{\rho} \cdot \frac{1}{\rho} (6\nu - 1)^{2n-\rho}; \end{aligned}$$

and

$$\begin{aligned} \int_0^1 \frac{(1-y)^{2n}}{6\nu + y} dy &= \int_0^1 \frac{(6\nu + 1)^{2n}}{6\nu + y} dy - \int_0^1 \frac{(6\nu + 1)^{2n} - (1-y)^{2n}}{(6\nu + 1) - (1-y)} dy = \\ &= (6\nu + 1)^{2n} \log \left(1 + \frac{1}{6\nu} \right) - \sum_{\rho=1}^{2n} \frac{1}{\rho} \cdot (6\nu + 1)^{2n-\rho}; \end{aligned}$$

so the calculation of $I(2n, \frac{1}{6})$ is to be reduced to the calculation of the integral

$$2 \int_0^1 (1-y)^{2n} \sum_{\rho=1}^{\infty} \frac{y^{2\rho-1}}{6^{2\rho}} \left\{ \zeta(2\rho) - \sum_{\nu=1}^q \frac{1}{\nu^{2\rho}} \right\} dy = 2 \cdot (2n)! \sum_{\rho=1}^{\infty} \frac{\zeta(2\rho) - \sum_{\nu=1}^q \frac{1}{\nu^{2\rho}}}{(2\rho)(2\rho+1)\dots(2\rho+2n) \cdot 6^{2\rho}}$$

and the ratio of two consecutive terms of this series is smaller than

$\frac{1}{6^2 (q+1)^2}$, so that, if there is a breaking off in an arbitrary place, the rest-term is smaller than the term last used divided by $6^2 (q+1)^2 - 1$.

KONINKLIJKE AKADEMIE VAN WETENSCHAPPEN
TE AMSTERDAM.

PROCEEDINGS

VOLUME XIX

N^o. 3.

President: Prof. H. A. LORENTZ.

Secretary: Prof. P. ZEEMAN.

(Translated from "Verslag van de gewone vergaderingen der Wis- en
Natuurkundige Afdeling," Vol. XXIV and XXV).

CONTENTS.

- H C DELSMAN "On the relation of the first three cleavage planes to the principal axes in the embryo of *Rana fusca* Rosel" (Communicated by Prof G C J VOSMAER), p 498
- M J HUIZINGA "Electrolytic phenomena of the molybdenite-detector" (Communicated by Prof H HAGA), p 512
- F A H SCHREINEMAKERS "In-, mono- and divariant equilibria" X, p 514
- W DE SITTER "On the relativity of rotation in EINSTEIN's theory", p 527
- M J VAN UVEN "Logarithmic Frequency Distribution" (Communicated by Prof J C KAPTEYN), p 533
- J M BURGERS "Note on P SCHERRER's calculation of the entropyconstant" (Communicated by Prof H KAMERLINGH ONNES), p 546
- G HOLST and E OOSTERHUIS "Note on the melting point of palladium and WIEN's constant c_2 " (Communicated by Prof H KAMERLINGH ONNES), p 549
- H ZWAARDEMAKER "The Electrical Phenomenon in Smell-mixtures", p 551
- H R KRUYT "The equilibrium solid-liquid-gas in binary systems which present mixed crystals" (Fourth communication) (Communicated by Prof ERNST COHEN), p 555
- J D JANSEN "On Nitro-derivatives of Alkyltoluidines and the relation between their molecular refractions and those of similar compounds" (Communicated by Prof P VAN ROMBURGH), p 564
- P EHRENFEST "On adiabatic changes of a system in connection with the quantum theory" (Communicated by Prof H A. LORENTZ), p 576
- S WEBER and E OOSTERHUIS "On the electric resistance of thin films of metal" (Communicated by Prof H KAMERLINGH ONNES), p 597
-

32

Proceedings Royal Acad. Amsterdam Vol. XIX.

Anatomy. — “*On the relation of the first three cleavage planes to the principal axes in the embryo of Rana fusca Rösel.*” By Dr. H. C. DELSMAN. (Communicated by Prof. VOSMAER).

(Communicated in the meeting of May 27, 1916).

In this paper the results are given of some pricking experiments on the eggs of *Rana temporaria*, which I hope may contribute to the solution of various questions about which unanimity of opinion has as yet not been attained in spite of the numerous investigations on the earliest development of the amphibian egg.

Starting point was the question: what becomes of the animal pole of the egg? It seemed very important to obtain an answer to this question in regard to a theory, worked out by me some years ago, on the evolution of the vertebrates from invertebrates (1913, a, b). The first principle on which this theory is based is that the invertebrate ancestor of the vertebrates must be sought among the Annelida, a suggestion which was upheld already half a century ago by DOHREN, SEMPER and by many others afterwards, and that the transition must be conceived to be such that the stomodaeum of the Annelida became the medullary canal of the Chordata. Since this last supposition is bold enough to endanger in some quarters the reputation of him who dares to put it forth (which I felt from the beginning), it was with great satisfaction that I found that nobody less than the discoverer of the neurenteric canal, KOWALEWSKY, in 1877 already had suggested a similar explanation, although less sharply formulated, when he wrote in a discussion on the homology of the nervous system in worms and chordates: “Die sonderbare Bildung des Nervensystems bei den Embryonen vieler Wirbelthiere (Amphioxus, Amphibien, Störe, Plagiostomen), bei denen Darm- und Nervenrohr ein zusammenhängendes Rohr darstellen, lässt uns vermuthen, dass vielleicht solche Thierformen existirten oder auch existiren, welche ein dem Nervenrohr der Wirbelthiere homologes Rohr besitzen, obgleich dasselbe eine andere Function erfüllt, dass es z.B. ein Theil des Darmcanals sei”.

The second idea underlying the theory proposed by me is that, whereas in *Amphioxus* the whole of the medullary canal must be regarded as homologous with the stomodaeum of the Annelida, in the Craniota the praechordal part of the cerebral plate must be considered as having originated from the so-called apical plate of the annelid larva, the trochophora, by annexation of this latter by the medullary canal. Without enlarging upon the different

arguments adduced by me for this second supposition, I here only will mention that formerly already I pointed out the possibility to prove or verify it by experiment. For in the centre of the apical plate the animal pole of the egg is found, characterised by the fact that there the extrusion of the polar bodies took place and the two first cleavage furrows crossed each other. A similar relation may now be expected to exist between the cerebral plate and the animal pole in the vertebrates, where the history of the animal pole cannot be traced with equal certainty, since the polar bodies do not stay there and the cleavage is not of such a kind that a definite point can be kept in view. Pricking experiments should bring certainty here.

If the cerebral plate of the Craniota is really homologous with the apical plate of the annelid (and mollusc) larva, it may be expected that we shall find back the animal pole on the cerebral plate. On closer examination it appears that this conclusion formerly drawn by me (1913 b) cannot be strictly correct. For a glance at the schemes then given of the structure of annelid, amphioxus and craniote shows at once that in the latter not only the cerebral plate must be furnished by the apical plate, but also, just as in the former two, the ectoderm covering the prostomium. Hence the cerebral plate can only originate from part of the apical plate and moreover this part must, according to the scheme mentioned, be the half of the top-plate contiguous to the stomodaeum (in casu the medullary canal), which consequently is the oral half in the Annelida, but the aboral half in the Chordata, where the old mouth loses its function and a new one breaks through at the opposite side. The other half then furnishes the ectoderm of the prostomium, not only ventrally, but also — the ectoderm cells during the closing of the cerebral plate evidently being shoved upwards on either side — dorsally, over the cerebrum. Now if the cerebral plate can be formed only from the posterior half of the apical plate, from the part where also with Annelids and Molluscs the rudiment of cerebral ganglia and eyes is found, it may be expected that the animal pole will be found back not so much on the cerebral plate as either on or just in front of its anterior border, i. e. on the transverse head-fold. A glance at the three above-mentioned schemes given by me shows plainly that there is every reason to expect the animal pole at the level of the neuropore of the Craniota. To prove this experimentally would not only afford a verification of my theory, which reached this conclusion by a quite different train of reasoning, but would compel also those who attach little value to such theories on the

ground that it is so long ago since the Vertebrata originated and nobody has witnessed the event and who would therefore be glad to see anatomy and embryology revert to the mere accumulation of facts without feeling any need for thoughts, to acknowledge that such a theory can occasionally lead to some good, as here to the statement of a new "fact": the relation between the animal pole and the cerebral plate in the Craniota.

The frog eggs were placed in a small glass-scale with water and cotton wool when in the 4- or 8-celled stage, after having been freed from the surrounding jelly and under weak microscopical enlargement were pricked with the point of the spine of a hedge-hog, in such a way however that only a very trifling wound was made, which requires a fair amount of practice and patience. For at a somewhat more serious lesion a considerable extraovate is at once protruded, the size of which still increases during the subsequent cleavage and which results in abnormal development. For this reason similar experiments undertaken last year did not yield a single reliable result and made me doubt, as SCHULTZE (1889) and H. V. WILSON (1900) did, of the value of pricking experiments like these. But this year I had better luck. To be sure such trifling wounds have the disadvantage that often they soon heal entirely and that the scab which is formed is cast off, but the development is not interfered with in the least, the egg remains movable within the egg capsule and consequently can assume the position of equilibrium corresponding to each developmental stage. The results turned out to be very satisfactory, although occasionally eggs had to be rejected in which the mark was cast off too early.

With eggs that had been pricked on the animal pole in the 4- or 8-celled stage and during gastrulation had been repeatedly sketched by means of the drawing-apparatus, so that more or less complete series were obtained, I finally found the mark just in front of the anterior border of the cerebral plate. In four eggs I could follow the process so far without accidents such as the coming off of the marks and in all these four cases the same result was obtained. Elsewhere I hope to give reproductions of some of these series.

This result is fully in accordance with what might be expected on my theory. But it does not stand alone. With other amphibian species, particularly with the American frog *Acris* and the axolotl (*Amblystoma*), EYCLESHYMER made the same experiment as early as 1895 and 1898 and in both these forms obtained exactly the same result. The mark here was found back either just in front of or upon or just behind the transverse head-fold. Not only in

Amphibia, however, but also in Teleostei, where the earliest development differs in so many respects from that of the Amphibia, it may be taken for granted that the animal pole afterwards exactly indicates the anterior end of the embryo. When in 1913 I tried to show that in the anchovy the cerebral plate occupies nearly the same place as the animal pole, I overlooked a paper in which SUMNER (1904) describes pricking experiments on teleostean eggs, particularly those of some North-American species of *Fundulus*. When he pricked in the centre of the still small germinal disc which later extends concentrically over the whole egg, this mark was also found back exactly in front of the foremost point of the rudiment of the embryo. This points to a general prevalence of such a relation between the animal pole and the cerebral plate in Craniota. Nevertheless it should be mentioned here that HELEN DEAN KING (1902) in *Bufo* and EYLESHYMER (1902) in *Necturus* concluded from similar pricking experiments that in these the animal pole is found some distance in front of the transverse head-fold and that the latter even lies halfway between animal pole and egg equator. However it seems to me that these last experiments are not so conclusive that they would preclude the possibility that on closer examination these forms also might turn out to conform to the rule. Further investigations on this point are wanted.

Besides the animal pole I marked in the 8-celled stage other crossing points of cleavage lines, especially the four intersections of the equatorial cleavage groove, which, as appears from fig. 1, lies at a considerable distance above the equator of the egg, and the two meridional grooves. We shall indicate these points by *b*, *c* and *d*, *b* lying on the side where the white area of the lower portion of the egg reaches farthest upwards and which must be denoted as the dorsal side. On the opposite ventral side *c* will lie, *d* denoting the two lateral crossing points. I did not succeed in marking also the vegetative pole without being troubled at once by a considerable extraovate. Each egg always had only one single mark. Although on some eggs marks were made in two or even three of the just-mentioned spots I am sorry I could pursue none of these eggs as far as the appearance of the medullary plate without all the marks, or all except one, coming off. Such eggs were always chosen which in the eight-celled stage presented the most regular appearance, without large "cross-lines" ("Brechungsfurchen") in the points of intersection and in which the highest point of the white area was exactly cut by one of the two meridional cleavage planes, so that it might be assumed that the first cleavage plane coincided with the

meridional plane of the fertilised egg. This point will be dealt with later.

By sketching the marked eggs from time to time with the drawing-prism I obtained several series, which may e.g. give exact information on the appearance and displacement of the blastoporic rim. On this point the most divergent opinions until the present day are met with among different investigators.

The oldest view is that the black hemisphere becomes the dorsal part of the embryo, so that the egg axis lies dorso-ventrally. As is well known PFLÜGER (1883) first pointed out that the blastopore moves forward over more than 90°, from the point where the dorsal lip first appears, from which PFLÜGER concluded that the foundation of the nervous system originates on the white hemisphere. He added however emphatically: "Um nicht missverstanden zu werden, möchte ich hervorheben, wie ich keineswegs bewiesen zu haben glaube, dass die ganze Uranlage des centralen Nervensystems ein Derivat der weissen Hemisphäre des Eies sei . . . so bleibt es denkbar, dass die vorderen Teile der Markanlage, die dem Gehirn und möglicherweise sogar dem oberen Teil des Rückenmarks entsprechen, sich in der schwarzen Hemisphäre bilden".

The controversy between ROUX (1888) and SCHULTZE (1887) is well known, the former of whom let the dorsal lip of the blastopore move over the white half of the egg through no less than 170—180°, so that the medullary canal consequently originated entirely on the white half, while SCHULTZE on the other hand declared all displacement of the blastopore border to be illusory and ascribed it to a rotation of the egg, so that it would just be on the black hemisphere that the medullary canal originates. Only on this point they agreed, but as we shall see, erroneously, that the egg axis afterwards has a dorsoventral direction. The place where the dorsal lip is first noticed is according to ROUX the rostral, according to SCHULTZE the caudal end of the embryo. BERTACCHINI (1899) and HERTWIG (1902) took the side of ROUX, LWORF (1894) that of SCHULTZE. Among later-investigators however, the opinion begins to prevail, that neither of the two conceptions mentioned is correct, but that the embryo is formed partly on the white, partly on the black hemisphere and that consequently the egg axis is not perpendicular to the longitudinal axis of the embryo but has more or less the same direction. This view was first put forth by ASSHETON (1895) and after him by KORSCH (1900), according to whom the egg axis lies in the embryo from a ventral point in front to a dorsal point behind. If SCHULTZE was of opinion that the formative material of the embryo lies entirely in front

of the dorsal blastopore border and ROUX, HERTWIG, BERTACCHINI that at first it surrounds the blastopore as a ring, according to KOPSCH there is some truth in both statements, the rudiment of the head being found in front of the newly formed blastopore lip, the contiguous rudiment of the dorsal parts of the trunk lying round the blastopore border in the semilunar stage. This last view is more and more accepted by later investigators (H. V. WILSON, 1900, 1902, KING, 1902, IKEDA, 1902) and also my experiments confirm it entirely, as will be shown. Moreover this result is in complete accordance with what might be expected on my theory. The view is gaining acceptance that the principal axis of the egg and the longitudinal axis of the embryo approximately coincide and that consequently, when the first cleavage of the egg separates the left and right halves of the embryo (which is so in the majority of cases, see later), the second cleavage will not separate rostral and caudal, but dorsal and ventral parts of the embryo. Meanwhile opinions still differ very much; thus BRACHET (1902, 1905) recently has maintained the view that the transverse headfold originates exactly in front of the spot where the blastoporic rim first appears, i.e. about the egg equator (ROUX's view), that consequently the embryo will lie entirely on the lower hemisphere of the egg, but that the caudal end does not, as ROUX thinks, extend on the other side as far as the equator, but no farther than just beyond the vegetative pole. The egg axis "n'est en relation avec aucun des axes principaux de l'embryon" (1905).

About the place where the dorsal lip first appears and about the extent of its progression over the surface of the egg, opinions are also rather divergent as yet. PFLÜGER and ROUX see the dorsal blastopore lip originate on the egg equator, PFLÜGER lets it travel a distance of a little over 90° , ROUX of $170-180^\circ$, MORGAN and UME TSUDA (1884) see it originate $\pm 30^\circ$ below the equator and travel 120° . ASSHETON (1894) and KOPSCH (1900), with whom IKEDA (1902) in the main agrees, also let it appear a little below the equator (according to KOPSCH on an average 25°) and move through a distance of $60-70^\circ$ (ASSHETON) to 75° (KOPSCH). BERTACCHINI (1899) again quite agrees with ROUX and estimate the distance travelled through a little under 180° . KING (1902) finds in *Bufo* a displacement of 140° from a point below the equator. EYLESHYMER gives no definite data on this point, his opinion would probably be in fair accordance with the results obtained by me.

By carefully watching the marked eggs and by drawing them repeatedly the above questions of course can be answered with certainty. The results of my experiments for *Rana fusca* I have

combined in a single figure, obtained by the combination of many other figures, two drawings being each time superposed and held up to the light, the details of one figure being in this way transferred to the other.

The eggs marked at the animal pole teach us what follows :

The dorsal blastoporic lip is formed very little below the equator (much less than 25° or 30° , see above) and immediately begins to grow over towards the vegetative side. The ventral blastopore lip is formed about diametrically opposite the animal pole,

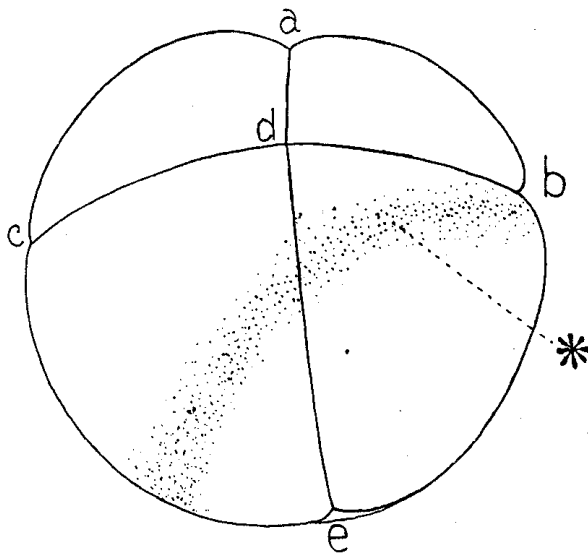

Fig. 1. Eight-celled stage seen laterally.
* confine between light and dark area.

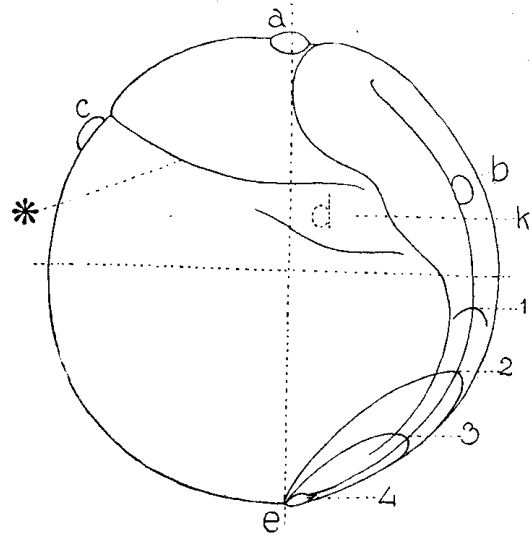

Fig. 2. Representation of the situation of the marks *a*, *b*, and *c* at the time of the appearance of the medullary plate and of the closing of the blastopore.

k. Rudiment of the gills.

1, 2, 3, 4 dorsal blastopore lip during the closing.

* edge of the so-called sense-plate.

a little bit more to the dorsal side. This border practically does not move so that the closing of the blastopore finally takes place at this same point. From this ensues that the dorsal blastopore lip progresses through a little less than 90° (estimation not under 80°).

When the blastopore has finally narrowed to a short slit and the medullary folds arise, this slit consequently still lies almost diametrically opposite the animal pole, which is situated exactly in front of the cerebral plate. The distance between the two is, when measured

dorsally, somewhat shorter than when measured ventrally. Hence the length of the dorsal embryonic rudiment is a little less than 180° . Although in yolk-laden eggs this arch has a somewhat smaller length, still the above relation seems to occur regularly in various animal groups. For besides in Amphibia we also find it in Teleostei, especially in those with pelagic eggs not too much yolk-laden it is generally observed that the closure of the blastopore takes place almost diametrically opposite the animal pole, i.e. the point of the nose, so that here also the embryo extends over almost 180° between the animal and vegetative poles. Far from a fundamental difference, as MORGAN (1894) thought, we find a fundamental agreement in the position of the embryo in amphibian and teleostean. Also for Amphioxus the same holds, CERFONTAINE'S (1906) pictures of gastrulas of Amphioxus with the second polar body still attached to it, show that here too the final narrowed blastopore lies approximately diametrically opposite the animal pole, while the dorsal blastopore lip is equally formed here near the egg equator.

We clearly see from fig. 2 that the place of the first appearance of the blastoporic rim lies about halfway the length of the embryo, that consequently the embryo is formed half on the black, half on the white hemisphere, and that the main axis of the egg coincides with the longitudinal axis of the embryo, so that the second cleavage of the egg in so-called typical development (ROUX, see later) separates the dorsal and ventral halves. Since in the 4- or 8-celled stage the distance from the animal to the vegetative pole (upper and lower crossing point of the first two cleavage planes) is also a little shorter when measured dorsally than when measured ventrally (the two ventral cells in stage 4 being somewhat larger than the two dorsal ones), it follows as well that the closure of the blastopore takes place exactly at the vegetative pole.

Let us now consider the eggs marked at *b*, *c*, or *d*, which are the points of intersection on the third or equatorial cleavage furrow. Since the roof of the cleavage cavity is getting continually thinner during the processes of cleavage and gastrulation, one would suppose that here an extension of surface takes place and that consequently the points *b*, *c*, and *d* move away from each other and from the animal pole. To my surprise however I found that, if this be the case, still it is to such a small extent that practically the little marks remain stationary. This wants explaining. It may be e.g. that the volume of the cells decreases by expulsion of liquid into the cleavage cavity, or by consumption of yolk by the cell-division which is particularly active here, or by both causes. Next year I hope to be

able to continue and repeat these experiments, as the number of eggs which in each of the cases reached the medullary plate stage without losing their marks did not exceed three or four. But the results of these agreed so completely that for the present my conclusion is that the marks at *b*, *c*, or *d* are not appreciably displaced.

When the dorsal blastopore lip is formed, the mark at *b* is found lying about equally far in front of it as in stage 8 the point *b* is distant from the egg equator. The more the blastopore lip is then shifted backwards the larger the distance becomes. At last the mark is found on the medullary plate exactly behind the cerebral plate.

The mark at *c* is found back at some distance before the anterior end of the cerebral plate in front of (properly speaking behind) the border of the so-called sense-plate, which lies round the front part of the cerebral plate in the shape of a crescent and the border of which (Fig. 2: *), as further development shows, indicates the border of the head as far as the gill arches. On this plate the two suckers, the mouth and the two olfactory grooves are afterwards found. Behind this plate lie on both sides of the anterior end of the medullary plate (behind the cerebral plate) two little projections (*k*), representing the rudiment of the gill arches. In this vicinity the mark *d* is found back of which I have not been able to fix the place with great accuracy since it was exactly in these eggs that the marks were lost when the medullary plate began to form. I could state however that these too do not appreciably move away from the animal pole, but that a small displacement seemed to take place in the direction of *b*, probably caused by the forming of the medullary plate and the accompanying thickening of the epithelium.

This shows that the third or equatorial cleavage in the egg of *Rana fusca* fairly well separates the head and the trunk, at any rate as far as the ectoderm is concerned. The rudiment of the head, taken as far as the gill slits, we find therefore in the four upper small blastomeres of the eight-celled stage, that of the trunk in the four large lower ones. Moreover it appears that the rudiment of the cerebral plate in stage 8 is found in the two smallest blastomeres of that stage, namely in the two animal and dorsal ones, each situated between the points *a*, *b*, and *d* and that these two blastomeres probably do not produce much more than just the cerebral plate. The two other animal blastomeres, the ventral ones, furnish the so-called sense-plate, i.e. the ectoderm of the head. Very attractive, also when viewing the pictures, is here the supposition that this sense-plate represents the remainder of the episphere of the trochophora. In this case the four animal cells of the eight-celled

stage of *Rana* would moreover in their prospective significance approximately agree with the corresponding four cells of the eight-celled stage of Annelida and Mollusca, i.e. with the so-called first quartet of micromeres, which in fact produces the top-plate. Still this supposition gives rise to considerable difficulties, which can only be overcome by additional suppositions. So e.g. the place of the mouth, which in Craniota lies behind the first body-segment, represented by the praemandibular mesodermic segment. Now if the supposition mentioned were right we should have to admit that the anterior mesodermic segments, as is the case in *Amphioxus* with the foremost point of the notochord, were pushed into the prostomium and that accordingly the mouth would also break through on the prostomium. For the olfactory grooves, which in Annelida lie on the border of prostomium and first segment, although occasionally a little way on the prostomium, a similar shifting would have to be admitted. This question seems for the present too difficult and too uncertain to be dealt with here.

So we see that while the rudiment of the cerebral plate originates in the animal half of the eight-celled egg, the rudiment of the remainder of the medullary plate is found in the four vegetative cells, chiefly of course in the two dorsal ones. This rudiment has, when the blastopore appears, the shape of a crescent, the largest breadth of which is measured by the distance between mark *b* and the blastopore lip. When the lip of the blastopore moves backward this maximum breadth increases proportionally to the distance between mark *b* and the rim of the blastopore. At the same time we may assume that just as the border of the blastopore goes on differentiating itself laterally from the cell-material there present, the crescentic rudiment of the medullary plate does the same, so that both horns of the crescent extend laterally backwards and finally almost join behind the blastopore. Meanwhile the possibility is granted that here a small gap remains, in regard to the eventual development of the anus from the posterior part of the blastopore. With the majority of more recent investigators I am of opinion that nothing pleads for concrescence taking place at the closure of the blastopore, unless at the very last when the blastopore occasionally assumes a pear-like shape, soon followed by the slit-shaped closure. I assume the caudally-excentric closure of the blastopore to be derived from a concentric, or perhaps even a rostrally-excentric one, such as is found in Annelida, by interference of this latter with a caudal shifting of the blastopore, which follows directly from my theory on the origin of the medullary canal from the stomodaeum of the Annelida and which is observed beautifully in Amni-

ota. In the same way as in Annelida the rudiment of the stomodaeum (WILSON, 1892, DELSMAN, 1916), so in Vertebrata the rudiment of the medullary canal (without the cerebral plate) lies in a crescent round the anterior border of the blastopore. The maximum breadth of this crescent continually increases during the closing of the blastopore and ultimately becomes the longitudinal axis of the medullary plate. I made different pricking experiments also during the closing of the blastopore, on which I shall not dwell here, since they did not lead to results deviating from those obtained by my predecessors ASSHETON, 1894, MORGAN and UMÉ TSUDA, 1894, EYCLESYMER, 1898, WILSON, 1900, KING, 1902. They confirmed the above conception.

That the closure of the blastopore is identical with the gastrulation of the Chordata will not be doubted by any one who has occupied himself with the gastrulation process in different groups of Evertebrata. Still I wish to emphasize this, since on the question what gastrulation in the Chordata really is, opinions have recently been put forth and accepted, also in my country, which I think must be entirely rejected. So HUBRECHT (1905) and BRACHET (1905), following ASSHETON, support the conception that the gastrulation (in the form of a delamination) would be completed already when the first blastopore lip appears and that the closure of the blastopore — by concrescence, according to the former two — is entirely independent of the gastrulation, but according to HUBRECHT would correspond to the concrescence of the buccal slit of an actinia (theory of SEDGWICK-LAMEERE). For this process the name notogenesis is introduced and the blastopore is henceforth called notopore. Some compatriots of a younger generation (BOEKE, 1907, DE LANGE, 1907, IHLF, 1913) have accepted this nomenclature together with the conceptions of the lately deceased nestor of Dutch embryologists. As has already been stated, I cannot agree with these and other conceptions of HUBRECHT, however cleverly they combine ideas borrowed from LWOFF, HERTWIG, VAN BENEDEN and others, if it were only since in my opinion nothing pleads for and everything against concrescence, while moreover it has been sufficiently demonstrated that not at all the whole of the medullary plate, as BRACHET thinks, or the epichordal part of it, as HUBRECHT assumed, is formed over the blastopore. My own conception about the gastrulation process of the anamnia is evident from the preceding pages, which moreover show how excellently the results of the later investigations agree with the conclusions arrived at by my theory.

Is the cerebral vesicle of Amphioxus homologous with the brain of the Craniota? This question I put in a preceding paper (1913, b).

I then tried to show that the polar body in *Amphioxus* would be situated at a considerable distance before the neuropore. Now it has turned out, however, that also in *Craniota* the animal pole does not come on, but in front of the cerebral plate. Does not this invalidate my former reasoning? In no way. If the reader will take the trouble to compare the two pictures of *Amphioxus* embryos reproduced in that paper, he will perceive at once that there can be no question that in *Amphioxus* the polar body will obtain a place corresponding to a mark on the animal pole of the frog egg, i.e. exactly in front of the neuropore. The distance from the neuropore is so large that it entirely agrees with the ideas then put forth by me and which are moreover supported by strong anatomical arguments, according to which the fore-brain proper of the *Craniota* is lacking in *Amphioxus*. As well in *Annelida* as in *Acrania* and *Craniota* we find that the animal pole finally lies approximately on the foremost point of the prostomium and therefore also of the body.

Finally a single experiment may still be mentioned, which I hope to extend later, but which already can confirm a conclusion lately reached by BRACHET in a different way. On the fertilised but still unsegmented frog egg a bilateral symmetry is soon observed, caused by the white — in the form of the so-called grey field (Roux) — extending on one side, the dorsal one, higher up towards the egg equator than on the other sides. In the majority of cases the first cleavage plane coincides with the plane of symmetry of the unsegmented egg and the symmetry-plane of the embryo is then in its turn the same as these two. Such eggs with "typical" development (Roux) I always selected, as was stated above, for the marks *a*, *b*, *c*, or *d*. Variations are not very rare, however, the first cleavage plane sometimes making a more or less considerable angle with the symmetry-plane of the egg, which angle may amount to 90° (anachronism of the two first cleavages). Now BRACHET by killing one of the first two blastomeres by means of a hot needle and by studying the so formed hemi-embryos, arrived at the conclusion that in such cases, in which the symmetry-plane of the egg and the first cleavage plane do not coincide, the symmetry-plane of the embryo corresponds to that of the egg and is independent of the direction of the first cleavage plane. This conclusion is confirmed by what follows.

I came across an egg in the eight-celled stage in which the highest point of the white field did not lie on one of the two vertical cleavage furrows, as is the case with typical cleavage, but halfway between the two, hence not under point *b*, but halfway between *b* and one of the *d*'s. Evidently the first and also the second division

had made here an angle of 45° with the symmetry-plane of the egg. Perhaps a couple of strong mutually perpendicular cross-lines ("Brechungsfurchen") at the animal and vegetative poles were also a result of this. Now I made a small mark on the equatorial cleavage furrow over the highest point of the "grey field", i.e. halfway between two points of intersection which may best be denoted by b and d , although in such a case this nomenclature does not hold, of course. The result was what might be expected according to BRACHET: the mark behaved entirely as a mark made at b in a "typical" egg. The blastopore lip was formed

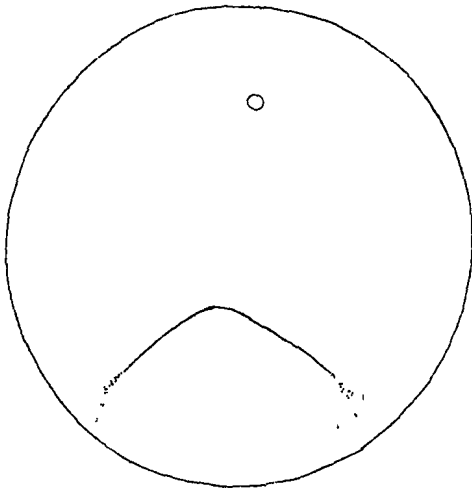

Fig. 3.

For explanation see the text.

Little mark right above the crescent-shaped blastopore border.

and contracted right under it (fig. 3) and finally lay on the middle of the medullary plate, just behind the cerebral plate. Hence the symmetry-plane of the embryo coincides with that of the unsegmented egg, independent of the direction of the first two cleavages. I hope very much that future years may offer an opportunity for continuing and extending these experiments, which are a first attempt to attain at something like cell-lineage investigations in vertebrates. Also on eggs of *Rana esculenta* I made some preliminary experiments, the results of which are very interesting and will be published shortly.

For the present it may be stated that between the directions of the first two cleavage planes and those of the main axes of the embryo no direct and constant relation exists. Such a relation does exist, however, between their line of intersection, the main axis of the egg, with which the longitudinal axis of the embryo (as long as the tail has not begun to develop) coincides. This also holds for the third cleavage plane which approximately separates head and trunk and to which accordingly a greater prospective significance must be attributed than to the former two.

LITERATURE.

ASSHETON, R., 1894, On the Growth in Length of the Frog Embryo. Quart. Journ. Vol. 37.

- BERTACCHINI, P., 1899, Morfogenesi e teratogenesi negli Anfibi anuri. Intern. Monatsschr. Anat. Phys. Bd. 16.
- BOEKE, J., 1907, Gastrulation en Dooieromgroeiing bij Teleostei. Versl. Kon. Acad. Wetensch. Amsterdam.
- BRACHET, A., 1902, Recherches sur l'ontogenèse des Amphibiens Urodèles et Anoures. Arch. Biol. T. 19.
- BRACHET, A., 1905, a, Recherches expérimentales sur l'oeuf de *Rana fusca*. ibid. T. 21.
- BRACHET, A., 1905, b, Gastrulation et Formation de l'Embryon chez les Chordés. Anat. Anz. Bd. 27.
- CERFONTAINE, P., 1906, Recherches sur le développement de l'Amphioxus. Arch. Biol. T. 22.
- DELSMAN, H. C., 1913, a, Der Ursprung der Vertebraten. Mitth. Zool. Station Neapel, Bd. 20.
- DELSMAN, H. C., 1913, b, Ist das Hirnbläschen des Amphioxus dem Gehirn der Kranioten homolog? Anat. Anz. Bd. 44.
- DELSMAN, H. C., 1916, Eifurchung und Keimblattbildung bei *Scoloplos armiger*. Tijdschr. Ned. Dierk. Ver. (2). Dl. 14.
- EYLESHYMER, A. C., 1895, The early Development of *Amblystoma*, with Observations on some other Vertebrates. Journ. Morph. Vol. 10.
- EYLESHYMER, A. C., 1898, The location of the Basis of the Amphibian Embryo. ibid. Vol. 14.
- EYLESHYMER, A. C., 1902, The Formation of the Embryo of *Necturus*, with Remarks on the Theory of Concrescence. Anat. Anz. Bd. 21.
- HERTWIG, O., 1892, Urmund und Spina bifida. Arch. mikr. Anat. Bd. 39.
- HUBRECHT, A. A. W., 1905, Die Gastrulation der Wirbeltiere. Anat. Anz. Bd. 26.
- IHLE, J. E. W., 1913, Die Appendicularien, *Ergebn. u. Fortschr. Zool.* Bd. 3, Heft 4.
- IKEDA, S., 1902, Contributions to the Embryology of Amphibia: The Mode of Blastopore Closure and the Position of the Embryonic Body. Journ. Coll. Sc. Imp. Univ. Tokyo, Vol. 17.
- KING, H. D., 1902, Experimental Studies on the Formation of the Embryo of *Bufo lentiginosus*. Arch. Entw. Mech. Bd. 13.
- KOPSCH, FR., 1900, Ueber das Verhältnis der embryonalen Axen zu den drei ersten Furchungsebenen beim Frosch. Intern. Monatsschr. f. Anat. u. Phys. Bd. 17.
- KOWALEWSKY, A., 1877, Weitere Studien über die Entwicklungsgeschichte des *Amphioxus lanceolatus*, nebst einem Beiträge zur Homologie des Nervensystems der Würmer und Wirbelthiere. Arch. mikr. Anat. Bd. 13.
- DE LANGE, D., 1907, Die Keimblätterbildung des *Megalobatrachus maximus*. Anat. Hefte, Bd. 32.
- LWOFF, B., 1894, Die Bildung der primären Keimblätter und die Entstehung der Chorda und des Mesodeims bei den Wirbeltieren. Bull. Soc. Impér. Nat. Moscou (2) T. 8.
- MORGAN, T. H. and TSUDA UMÉ, 1894, The Orientation of the Frog's Egg. Quart. Journ. Vol. 35.
- MORGAN, T. H., 1894, The Formation of the Embryo of the Frog. Anat. Anz. Bd. 9.
- PFLÜGER, E., 1883, Ueber den Einfluss der Schwerkraft auf die Teilung der Zellen. Arch. ges. Physiologie, Bd. 32.
- ROUX, W., 1883, Ueber die Lagerung des Medullarrohrs im gefurchten Froschei. Anat. Anz. Bd. 3.

some minutes, a small quantity of a dark blue liquid will appear on the surface of the crystal in which small gasbubbles rise. In one case e.g. the strength of the current was 6 milliampères, the impressed E. M. F. being 3 volt. If this E. M. F. between crystal and platinum fell to below 1,3 volt then the disengagement of gas could no longer be seen. If the E. M. F. of 3 volt was reversed, the current was only 0,5 milliampères, the disengagement of gas became less and could no longer be seen when the E. M. F. fell to 2 à 2,5 volt. By these experiments it is proved that in the contact molybdenite-metal, opposite to the direction of the primary current, an E. M. F. exists, due to polarisation, in consequence of electrolysis; the value of this E. M. F. of polarisation differs according to the direction of the primary current. By this the unipolar conduction has been reduced to well-known phenomena.

The inquiry into the electrolysis as appearing here, is not yet complète; though it has been found that the phenomena as described here, exactly agree with those obtained if the platinum point is brought into contact with the molybdenite not directly, but by means of a drop of acidulated water. Again the resistance is least in the direction from MoS_2 to Pt ; on the outer edge of the drop one can at first observe a green, after some time a dark-blue change of colour; without doubt an oxidation product of the mineral. In order to get the disengagement of gas the E. M. F. must be at least 1,2 volt; at the platinum point the colour of the liquid is somewhat brownish. If the current is reversed, then its strength possesses a greater value for some seconds, only to fall suddenly to a very small value. The disengagement of gas may be best seen on the side of the crystal and the liquid will also assume a brown colour on that side. In this case the disengagement of gas will only take place with an E. M. F. of 2 volt.

The intention is to extend the investigation to other combinations.

*Physical Laboratory
of the University Groningen.*

Chemistry. — “*In-, mono- and divariant equilibria*”. X. By Prof. SCHREINEMAKERS.

(Communicated in the meeting of September 27, 1916).

15. Special cases.

In previous communications we have treated the reaction-equations:

$$a_1 F_1 + \dots + a_p F_p + a_{p+1} F_{p+1} + \dots = 0. \quad (1)$$

and $\mu_1 a_1 F_1 + \dots + \mu_p a_p F_p + \mu_{p+1} a_{p+1} F_{p+1} + \dots = 0 \quad (2)$

in which a_i and μ_i are positive and at the same time

$$\mu_1 > \dots > \mu_p > \mu_{p+1} > \dots \quad (3)$$

We showed before in which way we are able to deduce from (1) and (2) the reaction-equations for the phases of each of the $n + 2$ equilibria (F_1), (F_2) etc. Suppose e.g. we want to find the reaction between the phases of the equilibrium (F_p), then we have to eliminate F_p from (1) and (2); then we obtain a reaction between $n + 1$ phases, viz. between all phases, except F_p .

This is, however, no more the case, when two of the values of μ in (3) are equal to each other; of course those may be only two values, succeeding one another, e.g. μ_p and μ_{p+1} . Instead of (3) we write then:

$$\mu_1 > \dots > \mu_{p-1} > \mu_p = \mu_{p+1} > \mu_{p+2} > \dots \quad (4)$$

If we put $\mu_p = \mu_{p+1} = \mu$ then (2) passes into:

$$\mu_1 a_1 F_1 + \dots + \mu a_p F_p + \mu a_{p+1} F_{p+1} + \dots = 0 \quad (5)$$

In order to find the reaction between the phases of the equilibrium (F_p) we have to eliminate F_p from (1) and (5); with this however not only F_p but also F_{p+1} disappears. Consequently we do not obtain a reaction between $n + 1$ phases, but a reaction between the n phases:

$$F_1 F_2 \dots F_{p-1} F_{p+2} \dots F_{n+2}$$

We find the same relation between these n phases for the reaction between the phases of the equilibrium (F_{p+1}). In each of the other reaction-equations for the monovariant equilibria however $n + 1$ phases occur.

In the equilibrium:

$$(F_p) = F_1 + \dots + F_{p-1} + F_{p+1} + \dots + F_{n+2}$$

consequently the phase F_{p+1} , and in the equilibrium:

$$(F_{p+1}) = F_1 + \dots + F_p + F_{p+2} + \dots + F_{n+1}$$

consequently the phase F_p takes no part in the reaction; for this

reason we call F_p and F_{p+1} indifferent phases. The equilibrium:

$$M = F_1 + \dots + F_{p-1} + F_{p+2} + \dots + F_{n+2}$$

shows something particular. Generally between n phases of a system of n components no phase-reaction can occur, viz. a reaction at which not the compositions, but the quantities of the phases change. [Indeed, however, a reaction may occur at which as well the composition as the quantities of the phases change]. In the equilibrium M however a reaction may occur, viz.:

$$(\mu_1 - \mu)a_1 F_1 + \dots + (\mu_{p-1} - \mu)a_{p-1} F_{p-1} + (\mu_{p+2} - \mu)a_{p+2} F_{p+2} + \dots = 0. \quad (6)$$

The phases of this equilibrium M have, therefore, something particular, we call them therefore "singular phases" and the equilibria M , $(F_p) = M + F_{p+1}$ and $(F_{p+1}) = M + F_p$ singular equilibria.

When in (3) three values of μ are equal to one another, then (3) passes into:

$$\mu_1 > \dots > \mu_{p-1} > \mu_p = \mu_{p+1} = \mu_{p+2} = \mu_{p+3} > \dots \quad (7)$$

Then we find for the reaction between the phases of each of the equilibria (F_p) , (F_{p+1}) and (F_{p+2}) a relation between the $n-1$ phases:

$$F_1 \dots F_{p-1} F_{p+3} \dots F_{n+2}$$

Then in the equilibrium (F_p) the phases F_{p+1} , and F_{p+2} , in (F_{p+1}) the phases F_p and F_{p+2} and in the equilibrium (F_{p+2}) the phases F_p and F_{p+1} do not participate in the reaction. The phases of the equilibrium:

$$M = F_1 + \dots + F_{p-1} + F_{p+3} + \dots + F_{n+2} \quad (8)$$

have, therefore, again something particular viz. that between them a phase-reaction is possible. Consequently we call them again singular phases and the equilibria:

$$M, (F_p) = M + F_{p+1} + F_{p+2}, \quad (F_{p+1}) = M + F_p + F_{p+2}$$

and $(F_{p+2}) = M + F_p + F_{p+1}$ singular equilibria.

Of course we may imagine still more of those particular cases; we shall refer to this later.

16. *The occurrence of two indifferent phases.*

When in an invariant point of a system of n components two indifferent phases occur, then the singular equilibrium consists of n phases.

When in a binary system two indifferent phases occur, then the singular equilibrium M contains, therefore, also two phases. These singular phases must be, therefore, convertible one into the

other, without other phases participating in this reaction, consequently they must have the same composition.

This is the case when in the quadruplepoint two modifications of a same substance occur e.g. red and yellow HgI_2 , or ice and water-vapour or, when e.g. naphthaline and a vapour, which consists of naphthaline only, occur. This is also the case, when a liquid has casually the same composition as a hydrate or as a vapour, etc. In the concentration-diagram those two singular phases are represented by the same point.

When in a ternary system two indifferent phases occur, then the singular equilibrium M consists, therefore, of 3 phases. Those three singular phases must have, therefore, such a composition that one of them can be separated into the other ones; consequently in the concentration-diagram those three phases are situated on a straight line.

This is the case when in the quintuplepoint occur e.g. the phases: watervapour + $Na_2CO_3 \cdot 10H_2O$ + $Na_2CO_3 \cdot 7H_2O$ or: watervapour + $Na_2SO_4 \cdot 10H_2O$ + Na_2SO_4 or when a liquid has casually such a composition that it may be separated into two other phases, etc. When in fig. 1 (VIII) Z_1, Z_2 and Z_3 are situated on a straight line, then G and L are the indifferent — and Z_1, Z_2 and Z_3 the singular phases; when L is situated casually on the line GZ_2 then Z_1 and Z_3 are the indifferent — and Z_2, L and G the singular phases.

When in a quaternary system two indifferent phases occur, then the singular equilibrium M consists, therefore, of four phases. Those four singular phases must have, therefore, such a composition that between them a phase-reaction is possible; consequently they must be situated in the concentrationdiagram in a plane. When in the figs. 1 (III), 3 (III), 5 (III) and 7 (III) e.g. C and E are the indifferent phases, then A, B, D and F are the singular phases and those must be situated in a plane.

Further we shall see that it is necessary to divide the singular equilibria M into two groups. When all phases of the equilibrium M have a constant composition, then we call M "constant singular"; when one or more of those phases have, however, a variable composition, then we call M "variable singular".

In a quadruple-point with the phases:

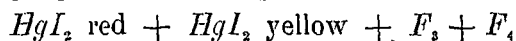

the equilibrium

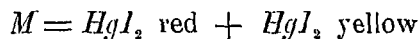

is therefore, constant singular. In the quintuplepoint:

$NaCl + Na_2SO_4 + Na_2SO_4 \cdot 10 H_2O + \text{solution} + \text{vapour}$
the equilibrium:

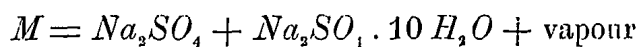

is also constant singular.

In a quadruplepoint

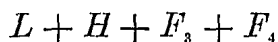

in which L is a liquid, which has casually the same composition as the solid phase (or a vapour) H , the equilibrium:

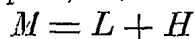

is variable singular. In the quintuplepoint:

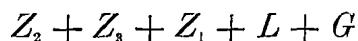

the equilibrium:

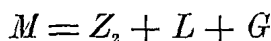

is variable singular, when we imagine in fig. 1 (VIII) the liquid L in the point d .

It is evident that between the two species of singularity a great difference exists. By a fit choice of the components we may obtain easily constant singular equilibria; the occurrence of variable singular equilibria is however very casual. As those species have also different properties, we shall discuss them separately.

17. *The occurrence of two indifferent phases; the equilibrium M is constant singular.*

The two indifferent phases F_p and F_{p+1} may either have in (1) the same sign or not. When they have in (1) the same sign, then they have it also in (5); when they have in (1) opposite signs, then this is also the case in (5). This is, however, also the case in each other reaction-equation. When we deduce from (1) and (5) another reaction-equation by multiplying the first one by k and the second one by l , then the coefficients of the indifferent phases F_p and F_{p+1} become:

$$(k + l) a_p \text{ and } (k + l) a_{p+1}$$

Hence it appears, therefore: when in a reaction-equation the indifferent phases have the same or the opposite sign, then they have it also in all other reaction-equations. [They have it, therefore, also in the isentropical and isovolumetrical reactions].

So, in order to decide whether the indifferent phases have the same sign, or not, it is only necessary to know, therefore, one single reaction.

When we imagine in fig. 1 (VIII) Z_2 in the point of intersection of the lines GZ_2 and Z_1Z_3 , then G and L are the indifferent phases.

In the reaction :



G and L have opposite signs, consequently they must have it also in all other reactions.

When we imagine in fig. 1 (VIII) Z_3 in the point of intersection of the lines GZ_2 and Z_1Z_3 , then Z_1 and L are the indifferent phases. In the reaction :

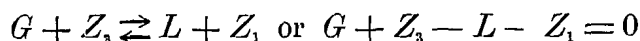

Z_1 and L have the same sign; consequently they must have it also in all other reactions.

A property of the singular equilibrium M is connected with the circumstance of the signs of the two indifferent phases being equal or not. We shall divide viz. those equilibria into transformable and not-transformable equilibria. We call it viz. transformable when the singular equilibrium M and the invariant equilibrium may be converted into one another, we call it not-transformable when this conversion cannot occur.

Let us imagine e.g. in fig. 1 (VIII) Z_2 in the point of intersection of the lines GZ_2 and Z_1Z_3 ; the indifferent phases are then G and L and the singular equilibrium is :

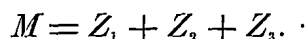

This equilibrium M is then not transformable, viz. it cannot be converted into the invariant equilibrium and reversally the invariant equilibrium cannot be converted into M .

When we imagine in fig. 1 (VIII) Z_3 in the point of intersection of the lines GZ_2 and Z_1Z_3 , then Z_1 and L are the indifferent phases and the singular equilibrium



is transformable. A complex of this singular equilibrium viz. is represented by a point of the line GZ_2 ; as this point is situated within the quadrangle GZ_1Z_2L , this complex may be converted into the invariant equilibrium.

A complex of the invariant equilibrium is situated within the quadrangle GZ_1Z_2L , when we give to this complex such a composition that it is represented by a point of the line GZ_2 , then the invariant equilibrium may be converted into the singular equilibrium M . The equilibrium M is, therefore, transformable.

Now we shall show :

When the two indifferent phases have the same sign, then the singular equilibrium M is transformable.

When the two indifferent phases have opposite sign, then the singular equilibrium M is not transformable.

Let the composition of the invariant equilibrium be:

$$A_1 F_1 + \dots + A_p F_p + A_{p+1} F_{p+1} + \dots + A_{n+2} F_{n+2}$$

in which A_1, A_2 etc. indicate the quantities of the phases, they are consequently positive. When in this equilibrium reaction (1) takes place, then the composition becomes:

$$(A_1 - Ka_1) F_1 + \dots + (A_p - Ka_p) F_p + (A_{p+1} - Ka_{p+1}) F_{p+1} + \dots \quad (9)$$

in which K is arbitrary. In order that (9) may represent the singular equilibrium M , the coefficients of the singular phases F_p and F_{p+1} must be zero and the coefficients of the other phases must be positive.

The latter condition can always be satisfied; for this it is only necessary to take large enough the quantities A_1, A_2 etc. of those phases. The first condition gives:

$$A_p - Ka_p = 0 \text{ and } A_{p+1} - Ka_{p+1} = 0 \text{ consequently } \frac{a_p}{a_{p+1}} = \frac{A_p}{A_{p+1}}$$

As A_p and A_{p+1} are both positive, a_p and a_{p+1} must have, therefore, the same sign. Moreover it appears that the invariant equilibrium may be converted into the equilibrium M only then when the quantities A_p and A_{p+1} of the indifferent phases are in the ratio of a_p to a_{p+1} .

Now we shall put the question, which P, T -diagramtypes answer those particular cases. We consider an invariant point with the phases $F_1 \dots F_{n+2}$, in which F_p and F_{p+1} are the indifferent phases and the other ones the singular phases.

Then we have the singular equilibria:

$$M = F_1 + \dots + F_{p-1} + F_{p+2} + \dots + F_{n+2}$$

$$(F_p) = F_1 + \dots + F_{p-1} + F_{p+1} + F_{p+2} + \dots + F_{n+2} = M + F_{p+1}$$

$$(F_{p+1}) = F_1 + \dots + F_{p-1} + F_p + F_{p+2} + \dots + F_{n+2} = M + F_p$$

When M is no singular equilibrium, no phase-reaction may occur, therefore, between its phases, then it is the bivariant equilibrium ($F_p F_{p+1}$) which is represented in a P, T -diagram by a region between the curves F_p and F_{p+1} .

When M is indeed a singular equilibrium, so that between its phases a phase-reaction can occur, then it is represented in the P, T -diagram by a curve (M).

Now we may show that the 3 singular curves (M) (F_p) and (F_{p+1}) coincide. This coincidence may take place in two different ways.

In fig. 1 ia represents the stable part and ib the metastable part or the three singular curves (M) (F_p) and (F_{p+1}). When we consider only the stable parts of the curves, then we may say: the three curves go, starting from the invariant point, in the same direction.

In fig. 2 curve (M) goes in stable condition through the invariant point i , it is represented by aib . The stable part of (F_p) is represented by ia , the metastable part by ib ; the stable part of (F_{p+1}) is represented by ib , the metastable part by ia . When we consider the stable parts only of (F_p) and (F_{p+1}), then we may say: the curves (F_p) and (F_{p+1}) go in the same direction, starting from the invariant point.

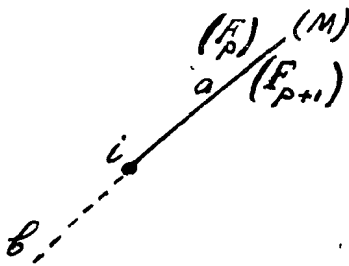

Fig. 1

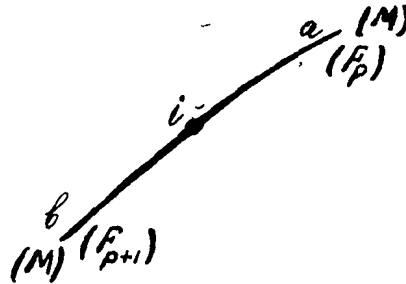

Fig. 2.

We shall express this in the following way:

Fig. 1. Curve M is monodirectionable; the three singular curves coincide in the same direction.

Fig. 2. Curve M is bidirectionable; the two other singular curves coincide in opposite direction.

We may show the above in the following way.

We consider the equilibrium $(F_p) = M + F_{p+1}$ at different temperatures and under corresponding pressure. When we take away from this equilibrium the phase F_{p+1} , then it passes into the equilibrium M ; as this equilibrium is represented by curve (M), the curves (M) and (F_p) therefore, coincide. The same is true for the curves (M) and (F_{p+1}), so that the three singular curves coincide.

From this coincidence however we may not yet conclude the position of the stable parts of those curves with respect to one another; in order to determine this position, we distinguish two cases:

1. The two indifferent phases have the same sign, the singular equilibrium M is, therefore, transformable into the invariant equilibrium and reversally.

2. The two indifferent phases have opposite sign, the singular equilibrium M is, therefore, not transformable.

Firstly we take the case 1, consequently: the two indifferent phases have the same sign.

Let us assume that the series of signs of reaction (1) is represented by:

$$\begin{array}{ccccccc} A & R & B & S & C & T & D \\ + \dots & | - \dots & | + \dots & | - \dots & | + \dots & | - \dots & | + \dots \end{array} \quad (10)$$

Consequently the P, T -diagram consists of seven bundles, in fig. 3 (V) we find a similar diagram, in which, however, the bundles $B, C, D, T,$ and S are drawn onecurvical. As the indifferent phases F_p and F_{p+1} have the same sign, they belong to a same group of series of signs (10) and the curves (F_p) and (F_{p+1}) belong to the same bundle of curves of the P, T -diagram [Fig. 3 (V)]. The curves (F_p) and (F_{p+1}) , therefore, coincide in the same direction, as in fig. 1.

In order to define the direction of the curve (M) we take the isovolumetrical or isentropical reaction [Communication IX] in which F_p and F_{p+1} have, therefore, also the same sign. Let us take the isovolumetrical reaction and let us assume that F_p and F_{p+1} have herein the positive sign. Now we cause the reaction to proceed in such direction, that the quantities of the phases, which have a positive sign, diminish. Then, besides perhaps also other monovariant equilibria, the singular ones $(F_p), (F_{p+1})$ and M may be formed. The stable parts of the singular curves $(F_p), (F_{p+1})$ and (M) go, therefore, starting from the invariant point in the same direction of temperature. [This is defined by the sign of $\Delta\eta$ in the isovolumetrical reaction]. When we take the isentropical reaction, then it appears that the three singular curves go in the same direction of pressure, starting from the invariant point.

The curves $(M), (F_p),$ and (F_{p+1}) are situated, therefore, with respect to one another as in fig. 1.

In the case 2 the two indifferent phases have opposite sign; consequently they belong in the series of signs (10) to two succeeding groups. When e.g. F_p is the last one of group A , then F_{p+1} is the first of group B ; when F_p is the last of group B , then F_{p+1} is the first of group C etc.

The two indifferent phases have, therefore, in all reactions, opposite sign, hence, also in the isentropical and in the isovolumetrical reaction. When the equilibrium (F_p) arises at a reaction in the one direction, then (F_{p+1}) may arise, when the reaction proceeds in the other direction. Hence it follows: the stable parts of the curves (F_p) and (F_{p+1}) go in opposite direction, starting from the invariant point.

The equilibrium M is not transformable, it may, therefore, not be converted into the invariant one, or be formed from the invariant one; the direction of the curve (M) starting from the invariant point may not be deduced, therefore, from this reaction. This follows at once, however, in the following way. When we take away, while

P and T do not change, from the equilibrium $(F_p) = M + F_{p+1}$ being in stable condition, the phase F_{p+1} , and from the equilibrium $(M_{p+1}) = M + F_p$ the phase F_p , then the equilibrium M remains, which must be then also stable. Each point of the stable part of the curves (F_p) and (F_{p+1}) represents, therefore, also a stable point of curve (M) ; the curves (M) , (F_p) and (F_{p+1}) are situated, therefore, with respect to one another as in fig. 2.

Consequently we find the following:

1. The two indifferent phases have the same sign, or in other words: the singular equilibrium M is transformable into the invariant equilibrium and reversally. Curve (M) is monodirectionable, the three singular curves coincide in the same direction [fig. 1].

2. The two indifferent phases have opposite signs or in other words: the singular equilibrium M is not transformable. Curve (M) is bidirectionable; the two other singular curves coincide in opposite direction [fig. 2].

It appears from the previous considerations what changes have to be applied to the general P, T -diagram types.

1. When the two indifferent phases F_p and F_{p+1} have the same sign, then the curves (F_p) and (F_{p+1}) belong to the same bundle. Consequently we may let two succeeding curves coincide in each bundle of the P, T -diagram. When in fig. 3 (V) A_1 and A_2 are the indifferent phases, then the curves (A_1) and (A_2) coincide, [in fig. 3 (V) the curves are not indicated by (A_1) , (A_2) etc. but, omitting the parentheses, by A_1 , A_2 etc.]; when A_2 and A_3 are the indifferent phases, then the curves (A_2) and (A_3) coincide; when R_1 and R_2 are the indifferent phases, then the curves (R_1) and (R_2) coincide; etc. Those coinciding curves represent then the singular curve (M) at the same time, as in fig. 1.

In fig. 1 d (V), therefore, the curves (S) and (Q) or (P) and (T) may coincide; in fig. 2 g (V) the curves (A) and (B) or (B) and (C) or (E) and (F) or (F) and (G) .

Consequently a coincidence of two curves in the same direction is only possible in P, T -diagrams with one or more morecurvical bundles.

2. When the two indifferent phases F_p and F_{p+1} have opposite sign, then the curves (F_p) and (F_{p+1}) belong to different bundles and in such a way, that the stable part of the one curve is situated next to the metastable part of the other curve. In fig. 3 (V), therefore, (A_3) and (R_1) or (R_3) and (B_1) etc. may coincide in opposite direction. Those coinciding curves represent then the singular curve (M) at the same time, as in fig. 2.

When F_1 and F_2 are the indifferent phases, then in (2) is $\mu_1 = \mu_2 = \mu$. It follows then from (2):

$$\mu a_1 - \mu a_2 + \mu_3 a_3 + \mu_4 a_4 + \dots + \mu_{n+2} a_{n+2} = 0. \quad (14)$$

Now is: $\mu_3 a_3 + \mu_4 a_4 + \dots = \alpha (a_3 + a_4 + \dots)$
 in which: $\mu_3 > \alpha > \mu_{n+2}$, consequently also $\mu > \alpha$.

We may write, therefore, for (14):

$$\mu (a_1 - a_2) + \alpha (a_3 + a_4 + \dots + a_{n+2}) = 0. \quad (15)$$

or with the aid of (13).

$$\mu (a_1 - a_2) - \alpha (a_1 - a_2) = 0 \quad (16)$$

As in accordance with (13) $a_1 - a_2$, cannot be zero, it follows, therefore, from (16): $\mu - \alpha = 0$, which is not possible. The phases F_1 and F_2 cannot be, therefore, in (12) the indifferent phases; the curves (F_1) and (F_2) cannot coincide, therefore, in opposite direction.

We shall call two curves, the stable parts of which are bordering one another, a monodirectionable pair of curves. [In fig. 2 g. (V) e.g. (A) and (B) or (B) and (C) or (G) and (F) etc.] Two curves, of which the stable part of the one curve borders the metastable part of the other curve, we call a bidirectionable pair of curves. [In fig. 2 g. (V) e.g. (A) and (D) or (G) and (D) etc.]

We may summarise the previous results in the following way:

In each P, T -diagram type the curves of each monodirectionable pair of curves may coincide in the same direction and the curves of a bidirectionable pair of curves may coincide in opposite direction. In a P, T -diagram with the two curves (X) and (Y) and a bundle (Z), (X) and (Y) however, cannot coincide.

Now it follows from our considerations that we may distinguish three main types of P, T -diagrams.

I. Curve (M) is monodirectionable [fig. 1].

The P, T -diagram has the same appearance as an ordinary P, T -diagram; as one of the curves represents however the three singular equilibria (M), (F_p) and (F_{p+1}) consequently only $n + 1$ curves occur. Therefore the P, T -diagram has the same appearance as a P, T -diagram of a system with $n - 1$ components.

When e.g. in the diagram of 4 components of fig. 2 (III) the curves A' and F' coincide, then this diagram gets the same appearance as the diagram of 3 components of fig. 4 (II). [We have to bear in mind that the figs. 4 (II) and 6 (II) have to be changed inter se]. Curve (4), however, represents then the three singular equilibria.

When in the diagram of 4 components of fig. 4 (III) the curves

B' and D' coincide, then it looks like the diagram of 3 components of fig. 2 (II). When in the diagram of 4 components of fig. 6 (III) the curves C' and E' coincide, then it looks like the diagram of 3 components of fig. 6 (II), when B' and D' or D' and A' coincide, then it looks like fig. 4 (II). When in fig. 8 (III) the curves C' and B' , or B' and D' or D' and A' coincide, then it looks like fig. 6 (II).

We shall call the bundle, to which curve (M) belongs, the (M)-bundle. It is apparent from the previous that this (M) bundle can consist either of one single curve [the (M)-curve] or of more curves.

II. Curve (M) is bidirectionable [fig. 2].

As curve (M) is bidirectionable, the one part [ia in fig. 2] represents the singular equilibrium (F_p) the other part [ib in fig. 2] represents the singular equilibrium (F_{p+1}). As the stable parts of those curves (F_p) and (F_{p+1}) go in opposite direction starting from the point i , we consider curve $ai b$ to consist of the two curves ia and ib . In the P, T -diagram of a system of n -components then $n + 2$ curves occur and not $n + 1$ curves only as in the case I.

We see at once that the curve (M) can never be situated in such a way that it is situated between stable parts of curves at both sides of the invariant point. In fig. 3 the one part of curve (M) is limited by stable parts of curves, the other part of curve (M) is situated, however, between metastable parts of curves. In fig. 4 each part of curve (M) is limited at the one side by stable, and at the other side by metastable parts of curves.

We may express this difference in the situation of curve (M) by saying: in fig. 3 (M) is a middlecurve, in fig. 4 (M) is a limit-curve of a bundle.

When we also here call, the bundle to which curve (M) belongs, the (M) bundle, then this consists of two parts. When we consider the stable parts only, then it consists in fig. 3 at the one side of the invariant point of the (M)-curve only, at the other side of a bundle; in fig. 4 it consists of a bundle at both sides of the invariant point.

Consequently we distinguish two cases.

A. Curve (M) is a middle-curve of the (M)-bundle [fig. 3].

We find in fig. 3, besides the (M)-bundle, yet some other bundles, viz. P , Q , R and S , of each of these bundles, however, one curve is only drawn.

It follows at once from a consideration of the stable and metastable parts of the bundles that always a same number of bundles must be situated at both sides of the (M)-bundle. Of course this

number may be also zero, we imagine e.g. the bundles P , Q , R and S to be omitted from fig. 3.

B. Curve (M) is a limit-curve of the (M) -bundle [fig. 4].

We find in fig. 4 besides the (M) -bundle, still the bundles P , Q and R ; of each of those bundles, however, one curve only is drawn.

Now we see easily that at the one side of the (M) -bundle always one bundle more than at the other side must be situated.

When we summarise the previous considerations, then we find the following three principal types.

I. Curve (M) is monodirectionable (fig. 1)

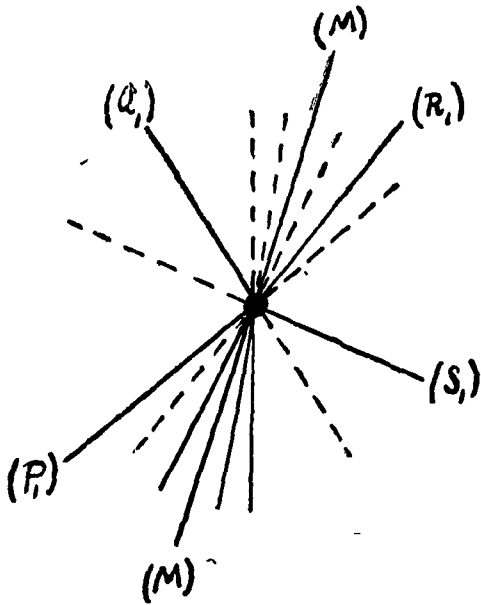

Fig. 3.

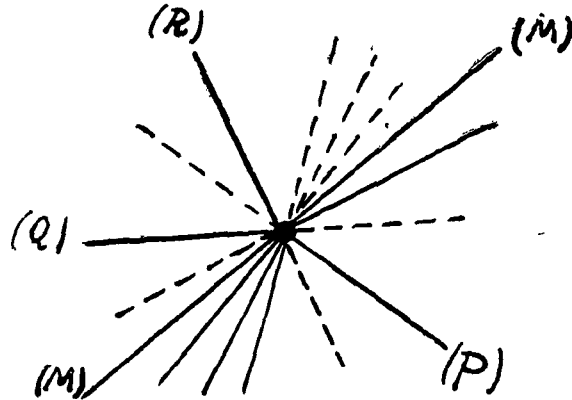

Fig. 4.

The P, T -diagram of a system of n components has the same appearance as that of a system with $n-1$ components.

II. Curve (M) is bidirectionable (figs. 2, 3, and 4).

A. Curve (M) is a middlecurve of the (M) bundle (fig. 3).

At both sides of the (M) -bundle always a same number of bundles is situated.

Consequently the P, T -diagram consists of a (M) -bundle + n bundles of curves at the one and n bundles of curves at the other side. The (M) -bundle contains four curves at least.

B. Curve (M) is a limit-curve of the (M) -bundle (fig. 4).

At the one side of the (M) -bundle [viz. at that side where is situated the (M) -curve] one bundle more than at the other side is always situated.

The P, T -diagram consists, therefore, of a (M) -bundle + n bundles

of curves at the one and $n + 1$ bundles of curves at the other side. The (M)-bundle contains four curves at least.

In following communications we shall apply those rules in order to deduce the types of the P, T -diagram, which may occur in the different systems of n components.

Leiden.

Inorg. Chem. Lab.

(To be continued).

Mechanics. — “*On the relativity of rotation in EINSTEIN’s theory.*”

By Prof. W. DE SITTER.

(Communicated in the meeting of September 30, 1916).

Observations have taught us that the relative accelerations of material bodies at the surface of the earth differ from those which would be caused by NEWTON’s law of gravitation only. The difference is explained by NEWTON’s law of inertia, combined with the rotation of the earth relatively to an “absolute space”. NEWTON¹⁾ quite deliberately introduces this absolute space, and also absolute time, as an element of his explanation of observed phenomena. Many objections have been raised against it, all of which are based on the logical claim that a true causal explanation shall involve only observable quantities. It has been tried to replace the absolute space by the fixed stars, by the “Body Alpha”, etc. All these substitutes are, however, entirely hypothetical and quite as objectionable, or more so, as the absolute space itself.

EINSTEIN²⁾ also rejects the absolute space, but he apparently still clings to the “ferne Massen”. It appears to me that EINSTEIN has made a mistake here. The “Allgemeine Relativitätstheorie” is in fact entirely relative, and has no room for anything whatever that would be independent of the system of reference. The need for the introduction of the distant masses arises from the wish to have the gravitational field zero at infinity in *any* system of reference. This wish, however well founded in a theory based on absolute space, is contrary to the spirit of the principle of relativity. The best way to show this clearly is to consider the fundamental tensor g_{ij} . We will, to simplify the argument, neglect the mass of the earth. This does not affect the fundamental question, if only we imagine the

¹⁾ Principia, Definitiones, Scholium.

²⁾ *Die Grundlagen der allgemeinen Relativitätstheorie*, Annalen der Physik, Band 49, p. 772 (separate edition p. 9).

experiments to be made with gyroscopes, instead of with FOUCAULT'S pendulum.

Take a system of coordinates $x_1 = r$, $x_2 = \vartheta$, $x_3 = z$, $x_4 = ct$, the axis of z being the axis of rotation of the earth, r and ϑ being polar coordinates in a plane perpendicular to it, and t the time. Now the argument which leads to the introduction of the distant masses is the following: If the earth had no rotation, the values of g_{ij} would be

$$\begin{matrix} -1 & 0 & 0 & 0 \\ 0 & -r^2 & 0 & 0 \\ 0 & 0 & -1 & 0 \\ 0 & 0 & 0 & +1 \end{matrix} \left. \vphantom{\begin{matrix} -1 \\ 0 \\ 0 \\ 0 \end{matrix}} \right\} \dots \dots \dots (1)$$

If we transform to rotating axes, by putting $\vartheta' = \vartheta - \omega t$, we find for g'_{ij} in the new system

$$\begin{matrix} -1 & 0 & 0 & 0 \\ 0 & -r^2 & 0 & -r^2\omega \\ 0 & 0 & -1 & 0 \\ 0 & -r^2\omega & 0 & +1 - r^2\omega^2 \end{matrix} \left. \vphantom{\begin{matrix} -1 \\ 0 \\ 0 \\ 0 \end{matrix}} \right\} \dots \dots \dots (2)$$

It is found that the set (1) does not explain the observed phenomena at the surface of the actual earth correctly, and (2) does, if we take the appropriate value for ω . This value of ω we call the velocity of rotation of the earth. Then relatively to the axes (2) the earth has no rotation, and we should expect the values (1) of g_{ij} . The g'_{24} and the second term of g'_{44} in (2) therefore do not belong to the field of the earth itself, and must be produced by distant masses.¹⁾

This reasoning is however faulty.

We will here only consider g_{24} . The differential equation determining this quantity, if we neglect the mass of the earth (or if we consider only the field outside the earth), is:

$$\frac{d^2 g_{24}}{dr^2} - \frac{2}{r^2} g_{24} = 0,$$

of which the general solution is

$$g_{24} = k_1 r^2 + \frac{k_2}{r},$$

where k_1 and k_2 are constants of integration. The equation as given here is not exact, as it supposes g_{24} to be small, and if k_1 is different

¹⁾ Evidently with NEWTON'S theory no masses will do this. The hypothesis therefore implies a change of NEWTON'S law of gravitation. Perhaps it will be possible with EINSTEIN'S theory to imagine masses producing the desired effect. The fixed stars will not do it.

from zero, this is not true for large values of r . It is found, however, that also the rigorous equation¹⁾ is satisfied by

$$g_{24} = k r^2, \dots \dots \dots (3)$$

k being an arbitrary constant. It will be seen that both (1) and (2) are special cases of the general formula (3). The flaw in the argument used above was that (1) was considered to be *the* solution, instead of (3). EINSTEIN'S theory in fact requires that g_{24} shall be of the form (3), but it does not prescribe the constant of integration. NEWTON'S theory did, and even therein lay its absolute character. EINSTEIN'S theory however is relative: in it the *differential* equation is the fundamental one, and the choice of the constants of integration remains free.

The constants of integration must, in a given system of reference, be so determined that the observed relative motions are correctly represented. In a true theory of relativity not only does the transformed general solution satisfy the invariant differential equation, but the particular solution which agrees with observed phenomena in one system must by the transformation give the particular solution which does so in the new system. Consequently the constants of integration must also be transformed and will generally be different in different systems.

Suppose that we have originally taken a system of coordinates relatively to which the earth has a rotation ω_1 . This ω_1 is, of course, entirely arbitrary and, as our coordinate axes cannot be observed, it must in a true theory of relativity disappear from the final formulae. Now we have $g_{24} = k r^2$, and to determine k , we transform to axes relatively to which the earth has no rotation by $\mathfrak{D} = \mathfrak{D} - \omega_1 t$.

Then in the new system

$$g'_{24} = (k - \omega_1) r^2.$$

Observation shows that the correct value of g'_{24} in this system is $-\omega r^2$, therefore

$$k = \omega_1 - \omega \dots \dots \dots (4)$$

If we use this value of k , the final formulas for the motion of bodies relatively to the earth contain only the observable quantity ω . The relativity of the theory is thus seen to be based on the free choice of the constant of integration k . No value of k is a priori

¹⁾ The second term, which is small also if r is large, has a more complicated form in the rigorous solution. It does not interest us here, as it is of the order of the mass of the earth. By the "rigorous equation" is meant the complete equation for g_{24} , not reduced to its linear terms, but in which the other g_{ij} are supposed to be known functions of the coordinates.

and (5) gives $k = 0$. But the conviction that this is the true value, and has any preference over any other values, is based on the belief in an absolute space, and must be abandoned if the latter is abandoned. We must do one of two things. Either we must believe in an absolute ¹⁾ space, to which we may impart some substantiality by calling it "Ether". Then $k = 0$ is the true value, and that this is so is a property of space or of the ether. Or we can believe that there is no absolute space. Then we must regard the differential equations as the fundamental ones, and be prepared to have different constants of integration in different systems of reference.

The difference between the two points of view is shown very clearly by the values of g_{24} for $r = \infty$. In the absolute space we have $g_{24} = 0$ at infinity. In EINSTEIN's theory the value of g_{24} at infinity is different in different systems of coordinates. However, no observation has ever taught us anything about infinity and no observation ever will. The condition that the gravitational field shall be zero at infinity forms part of the conception of an absolute space, and in a theory of relativity it has no foundation. ²⁾

¹⁾ It should be noted that, owing to the indeterminateness of EINSTEIN's field-equations, this "absolute" space is *not* completely determined by the condition that the fixed stars shall have no rotation in it, or that at an infinite distance from any material body the gravitational field shall be zero. There are an infinity of systems satisfying these conditions. We can limit the choice e.g. by putting $g = -1$, as EINSTEIN generally does, but even this does not fix the system of reference, and it is also entirely arbitrary.

²⁾ We could imagine that there was a system of degenerated values towards which the g_{ij} could converge in infinity, and which were invariant for all transformations, or at least for a group of transformations of so wide extent that the restriction of the allowable transformations to this group would not be equivalent to giving up the principle of relativity. Prof. EINSTEIN has actually found such a set of values. They are

$$\begin{matrix} 0 & 0 & 0 & \infty \\ 0 & 0 & 0 & \infty \\ 0 & 0 & 0 & \infty \\ \infty & \infty & \infty & \infty^2 \end{matrix} \left. \begin{matrix} \\ \\ \\ \end{matrix} \right\} \dots \dots \dots (\alpha)$$

and we must limit ourselves to such transformations in which at infinity x'_4 is a function of x_4 alone. Consequently the hypothesis that the g_{ij} actually have these values at infinity, and that at finite, though very large, distances from all known masses there are other unknown masses which cause them to have these values, is not contrary to the formal principle of relativity. But also denying the hypothesis is not contrary to this principle. The hypothesis has arisen from the wish to explain not only a small portion of the g_{ij} (i.e. of inertia) by the influence of material bodies, but to ascribe *the whole of the g_{ij}* [or rather the whole of the difference of the actual g_{ij} from the standard values (α)] to this influence. Theoretically it is certainly important that thus the *possibility* has been shown

Rotation is thus relative in EINSTEIN'S theory. Does this mean that it is physically equivalent to translation, which is also relative (and was relative in classical mechanics)? Evidently not. The fundamental difference between a uniform translation and a rotation is that the former is an *orthogonal* transformation (LORENTZ-transformation) of the four coordinates, or world-parameters, and the latter is not. Now orthogonal transformations are the only ones that leave the line-element invariant *in the coordinates*, i.e. that do not affect the g_{ij} , and are therefore without influence on the gravitational field. Consequently we can by a LORENTZ-transformation "transform away" linear velocity. We can always find a system of reference relatively to which a given body has no rotation, as we can find a system in which the acceleration produced by a given body at a given point is zero, but we cannot transform away rotation, no more than mass. This is a fact, independent of all theories. Of course the fact is differently represented in different theories. NEWTON "explains" it by his law of inertia and the absolute space. For EINSTEIN, who makes no difference between inertia and gravitation, and knows no absolute space, the accelerations which the classical mechanics ascribed to centrifugal forces are of exactly the same nature and require no more and no less explanation, than those which in classical mechanics are due to gravitational attraction.

of an entirely material origin of inertia. But practically it makes no difference whether we explain a thing by an uncontrollable hypothesis invented for the purpose, or not explain it at all. The hypothesis implies the finiteness of the physical world, it assigns to it a priori a limit, however large, beyond which there is *nothing* but the field of the g_{ij} which at infinity degenerate into the values (z). This field, in which also the fourdimensional time space is separated into a threedimensional space and a onedimensional time, undoubtedly has some of the characteristics of the old absolute space and absolute time. The hypothesis can thus be said to make space and time absolute at infinity, although arbitrary transformations of three-dimensional space are still allowed. If we wish to have complete four-dimensional relativity for the actual world, this world must of necessity be finite [Note added (29 Sept.) after a conversation with Prof. EINSTEIN].

Mathematics. — “*Logarithmic Frequency Distribution*”. By Dr. M. J. VAN UVEN. (Communicated by Prof. J. C. KAPTEYN).

(Communicated in the meeting of September 30, 1916).

When the frequency-distribution of some measured quantity x does not follow the normal law of GAUSS:

$$W_{\xi_1}^{\xi_2} = \frac{h}{\sqrt{\pi}} \int_{\xi_1}^{\xi_2} e^{-h^2 \xi^2} d\xi,$$

$\xi = x - X$ being the deviation from the arithmetical mean X and $W_{\xi_1}^{\xi_2}$ the probability that this deviation is found between the limits ξ_1 and ξ_2 (the measured quantity between $x_1 = X + \xi_1$ and $x_2 = X + \xi_2$), this need not be a reason to drop the law of GAUSS, as Prof. J. C. KAPTEYN has shown.¹⁾ On the contrary the “skewness” of the frequency-curve may in many cases be explained by merely supposing that, instead of x , another quantity $Z = F(x)$ connected with x is distributed according to this law, so that it is only due to the wrong choice of the quantity measured, that the normal distribution has not come out. Then it is interesting to deduce the normal function $Z = F(x)$ from the given skew frequency-distribution.

Let this normal function Z have the value M for its arithmetical mean, so that the deviations $\zeta = Z - M$ are spread round the mean value zero according to the normal law, and thus satisfy the equation

$$W_{\zeta_1}^{\zeta_2} = \frac{h}{\sqrt{\pi}} \int_{\zeta_1}^{\zeta_2} e^{-h^2 \zeta^2} d\zeta.$$

Among the quantities $\zeta = F(x) - M$, which apparently are also functions of the observed quantity x , there is one, viz. $z = h\zeta = h\{F(x) - M\} = f(x)$, which answers to the formula

$$W_{z_1}^{z_2} = \frac{1}{\sqrt{\pi}} \int_{z_1}^{z_2} e^{-z^2} dz.$$

This z has $h = 1$ for its modulus of precision and consequently $\epsilon_z = \frac{1}{\sqrt{2}}$ for its (quadratic) mean value.

¹⁾ J. C. KAPTEYN: *Skew Frequency Curves in Biology and Statistics*; Groningen, 1903, Noordhoff.

As has been shown by Prof. J. C. KAPTEYN and the author of this paper ¹⁾, the normal function $z = f(x)$ may be determined from the given frequency-distribution, at any rate graphically.

A normally distributed quantity may be considered as the result of growing from an initial value x_1 , common to all the individuals, with increments individually different but distributed round the mean increment according to the normal law of error, and independent of the instantaneous value of x .

When spread in a skew distribution, the quantity is built up of elementary increments which contain a factor $\psi(x)$ dependent on the x undergoing the increment. Thus the cause of growing being supposed to be spread purely accidentally, the reaction upon it is proportional to the function $\psi(x)$, which is called the "reaction-function" and is determinate but for a constant factor.

According to the theory of Prof. J. C. KAPTEYN the following relation holds between the reaction-function $\eta = \psi(x)$ and the normal function $z = f(x)$:

$$\eta = \psi(x) = \frac{dx}{dz} = \frac{1}{f'(x)}.$$

Thus far ¹⁾ some normal functions have been examined analytically, viz. that which answers to the normal distribution $z = \lambda(x - x_m)$ with $\eta = \frac{1}{\lambda}$, and those which correspond to the so-called "logarithmic distri-

bution": $z = \lambda \log \frac{x - x_0}{x_m - x_0}$ with $\eta = \frac{x - x_0}{\lambda}$ and $z = \lambda \log \frac{x_n - x_m}{x_n - x}$ with

$\eta = \frac{x_n - x}{\lambda}$ ($\lambda > 0$, $x_0 < x < x_n$). In the normal distribution the reaction-function η is a constant, in the logarithmic distribution η is a *linear* function of x .

In the present paper we shall treat the also logarithmic case that the reaction-function is a *quadratic* function of x . Then the normal function is of the form:

$$z = \lambda \log \left(\frac{x - x_0}{x_n - x} : \frac{x_m - x_0}{x_n - x_m} \right).$$

The general method furnishes the values z_k corresponding to the $n-1$ class-limits x_k . The curve which can be drawn through the points (x_k, z_k) is the graph of the normal function $z = f(x)$.

¹⁾ J. C. KAPTEYN and M. J. VAN UVEN: Skew Frequency Curves in Biology and Statistics, 2nd Paper; Groningen, 1916, Hoitsema Br.

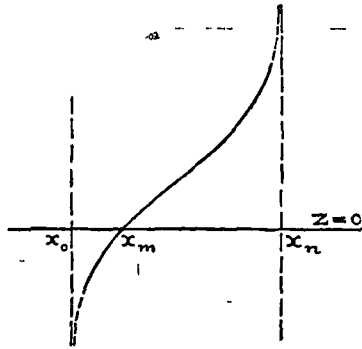

FIG. 1.

When the points (x_k, z_k) lie in a curve of the form shown (fig. 1), which appears to tend asymptotically to the ordinate-lines $x = x_0$ and $x = x_n$ of the extreme limits x_0 and x_n of x , a trial with

$$z = \lambda^{10} \log p \frac{x - x_0}{x_n - x} \quad (1)$$

suggests itself.

Introducing the median x_m (corresponding to $z = 0$) we find

$$p = \frac{x_n - x_m}{x_m - x_0} \quad (2)$$

and therefore

$$z = \lambda^{10} \log \left(\frac{x - x_0}{x_n - x} \cdot \frac{x_m - x_0}{x_n - x_m} \right) \quad (3)$$

Now we have to determine the constants x_0 , x_n , x_m and λ from the given curve. The curve on ordinary squared paper still furnishes the value x_m .

From

$$\frac{dz}{dx} = \lambda M \left[\frac{1}{x - x_0} + \frac{1}{x_n - x} \right] = \frac{\lambda M (x_n - x_0)}{(x - x_0)(x_n - x)} = \frac{\lambda M (x_n - x_0)}{-x^2 + (x_0 + x_n)x - x_0 x_n} \quad (4)$$

$(M = \text{mod} = {}^{10}\log e = 0.434295)$

and

$$\frac{d^2z}{dx^2} = \frac{\lambda M (x_n - x_0) [2x - (x_0 + x_n)]}{(x - x_0)^2 (x_n - x)^2} \quad (5)$$

we find for the coordinates (ξ, ζ) of the point of inflexion $\left(\frac{d^2z}{dx^2} = 0\right)$

$$\xi = \frac{x_0 + x_n}{2}, \quad \zeta = \lambda^{10} \log p = \lambda^{10} \log \frac{x_n - x_m}{x_m - x_0} \quad (6)$$

and for the slope ζ' at this point

$$\zeta' = \left(\frac{dz}{dx}\right)_\xi = \frac{\lambda M (x_n - x_0)}{(\xi - x_0)(x_n - \xi)} = \frac{4\lambda M}{x_n - x_0} \quad (7)$$

In general the position of the point of inflexion itself, situated at equal distances from both the asymptotes, cannot be fixed exactly. On the other hand the position of the inflexion tangent is pretty well determinate; its equation runs

$$z - \zeta = \zeta' (x - \xi);$$

The point of intersection with the axis of x has for abscissa:

$$\bar{x} = \xi - \frac{\xi}{\xi'} = \frac{x_0 + x_n}{2} - \frac{x_n - x_0}{4M} {}^{10}\log \frac{x_n - x_m}{x_m - x_0} \dots \dots (8)$$

Putting

$$x_n - x_0 = a, \\ \xi - x_m = \frac{x_n + x_0}{2} - x_m = d,$$

we obtain

$$x_m - \bar{x} = \frac{2x_m - x_0 - x_n}{2} + \frac{a}{4M} {}^{10}\log \frac{x_n - x_m}{x_m - x_0}$$

or

$$x_m - \bar{x} = -d + \frac{a}{4M} {}^{10}\log \frac{\frac{a}{2} + d}{\frac{a}{2} - d} = -d + \frac{a}{4M} {}^{10}\log \frac{1 + \frac{2d}{a}}{1 - \frac{2d}{a}} = \\ = -d + \frac{a}{4} {}^{10}\log \frac{1 + \frac{2d}{a}}{1 - \frac{2d}{a}}$$

Since $2d < a$ the logarithm may be expanded in ascending powers of $\frac{2d}{a}$:

$$\log \frac{1 + \frac{2d}{a}}{1 - \frac{2d}{a}} = 2 \left[\frac{2d}{a} + \frac{1}{3} \left(\frac{2d}{a} \right)^3 + \frac{1}{5} \left(\frac{2d}{a} \right)^5 + \dots \right] = \frac{4d}{a} + \frac{16d^3}{3a^3} + \frac{64d^5}{5a^5} + \dots$$

Hence

$$x_m - \bar{x} = -d + \frac{a}{4} \left[\frac{4d}{a} + \frac{16d^3}{3a^3} + \frac{64d^5}{5a^5} + \dots \right] = \frac{4d^3}{3a^2} + \frac{16d^5}{5a^4} + \dots (9)$$

or approximately

$$x_m - \bar{x} = \frac{4d^3}{3a^2} \dots \dots \dots (9a)$$

If the point of inflexion can be determined, at least by a rough estimate, a provisional value of $d = \xi - x_m$ is found. By computing a from the formula (9a) we also obtain provisional values for

$$x_0 = \xi - \frac{a}{2} \text{ and } x_n = \xi + \frac{a}{2}.$$

Finally λ is found from (7) viz.

$$\lambda = \frac{a \xi'}{4M}$$

If the limits x_0 and x_n are known beforehand, it is easy to determine λ and x_m graphically.

Indeed, putting

$$u = {}^{10}\log \frac{x-x_0}{x_n-x},$$

and operating with z and the numerus $v = \frac{x-x_0}{x_n-x} = 10^u$ on logarithmic paper, we obtain the graph of the equation:

$$z = \lambda(u - u_m),$$

which is a straight line with the (positive) slope λ ; this line cuts the axis of u at the point $u = u_m$ corresponding to the median x_m . At the margin of the logarithmic paper we read at u_m the numerus $v = v_m = 10^{u_m} = \frac{x_m - x_0}{x_n - x_m}$, from which x_m can be calculated $\left(x_m = \frac{x_0 + v_m x_n}{1 + v_m}\right)$, when not yet determined by the figure on ordinary squared paper.

In practice we are obliged to estimate the values of x_0 and x_n and to use, at least provisionally, erroneous values x_0' and x_n' of the limits. So we operate with

$$u' = {}^{10}\log \frac{x-x_0'}{x_n'-x}$$

instead of u , and thus obtain a set of pairs (u', z) lying in a curve slightly deviating from the true straight line $z = \lambda(u - u_m)$.

Let the errors in the presumed values x_0' and x_n' be σ and τ , so that

$$\begin{aligned} x_0' - x_0 &= \sigma, \\ x_n' - x_n &= \tau. \end{aligned}$$

then, putting

$$\frac{x-x_0}{x_n-x} = v, \quad \frac{x-x_0'}{x_n'-x} = v'$$

and, accordingly

$$u = {}^{10}\log v, \quad u' = {}^{10}\log v',$$

we derive

$$x = \frac{x_n'v' + x_0'}{v' + 1}$$

and

$$v = \frac{(x_n'v' + x_0') - (v' + 1)x_0}{(v' + 1)x_n - (x_n'v' + x_0')} = \frac{(x_n' - x_0)v' + (x_0' - x_0)}{-(x_n' - x_n)v' + (x_n - x_0')} = \frac{(a + \tau)v' + \sigma}{-\tau v' + (a - \sigma)}, \quad (10)$$

or, putting

$$\frac{\sigma}{a + \tau} = \beta, \quad \frac{-\tau}{a - \sigma} = \gamma,$$

$$v = \frac{a+\tau}{a-\sigma} \times \frac{v'+\beta}{\gamma v'+1} \quad \dots \quad (11)$$

Now

$$z = \lambda u + \text{const} = \lambda^{10} \log v + \text{const} = \lambda M \log v + \text{const},$$

$$\frac{dz}{du'} = \frac{dz}{dv'} \cdot \frac{dv'}{du'} = \lambda M \left(\frac{1}{v'+\beta} - \frac{\gamma}{\gamma v'+1} \right) \cdot \frac{v'}{M} = \frac{\lambda(1-\beta\gamma)v'}{(v'+\beta)(\gamma v'+1)} \quad (12)$$

and

$$\frac{d^2z}{du'^2} = \frac{d\left(\frac{dz}{du'}\right)}{dv'} \cdot \frac{dv'}{du'} = \frac{\lambda(1-\beta\gamma)v'}{M} \cdot \frac{-\gamma v'^2 + \beta}{(v'+\beta)^2(\gamma v'+1)^2} \quad (13)$$

The factor

$$1 - \beta\gamma = 1 + \frac{\sigma\tau}{(a+\tau)(a-\sigma)} = \frac{a(a+\tau-\sigma)}{(a+\tau)(a-\sigma)}$$

is positive, provided that σ and τ are sufficiently small.

Also the quantity $v = 10^u$ is always positive, as long as u' is real.

The quantity v is, $\frac{a+\tau}{a-\sigma}$ being supposed positive, also positive, without restriction when β and γ are both positive, provided that $v' > -\beta$ when β is negative, and provided that $v' < -\frac{1}{\gamma}$ when γ is negative.

The domain of reality for u , and hence also for z , is limited by the values $-\beta$ and $-\frac{1}{\gamma}$ for v' , or by the values $u' = \log(-\beta)$ and $u' = \log(-\frac{1}{\gamma})$ for u' . These limits really exist if $\beta < 0$ and $\gamma < 0$ resp., or $\sigma < 0$ and $\tau > 0$ resp.

When β is a small negative quantity, the value $u' = \log(-\beta) = -B$ is negative and rather large.

When γ is a small negative quantity, $-\frac{1}{\gamma}$ is a large positive quantity and the value $u' = \log(-\frac{1}{\gamma}) = +C$ is positive and rather large.

As for $u' = -B$ we have $v = 0$, or $u = -\infty$, hence $z = -\infty$, the ordinate line $u' = -B$ is a vertical asymptote lying to the left at a rather great distance from the centre of the domain; and, as for $u' = +C$ we have $v = \infty$, or $u = +\infty$, hence $z = +\infty$, also the ordinate line $u' = +C$ is a vertical asymptote lying to the right at a rather great distance from the centre of the domain.

So, when $\beta < 0$ or $\sigma < 0$, the real domain is limited by a vertical

asymptote $u' = -B$ on the left, and when $\lambda < 0$, or $\tau < 0$, it is limited by a vertical asymptote $u' = +C$ on the right.

As the real domain never extends beyond $u' = -B$ and $u' = +C$, the slope $\frac{dz}{du'}$ may never become negative, and the quantities u and u' are simultaneously maximum and minimum.

When σ has a small positive value, $u' = -\infty$ or $v' = 0$ answers to $v = \frac{\sigma}{a-\sigma}$ or $u = \log \frac{\sigma}{a-\sigma} = -S$, which is a rather large negative quantity. So for $\sigma > 0$ or $\beta < 0$ there exists an inferior limit $z = \lambda(-S - u_m)$ for z , corresponding to $u' = -\infty$, consequently a horizontal asymptote below.

When τ has a small negative value, $u' = +\infty$ or $v' = +\infty$ corresponds to $v = \frac{a+\tau}{-\tau}$, or $u = \log \left(\frac{a+\tau}{-\tau} \right) = +T$, which is a rather large positive quantity. So for $\tau < 0$ or $\gamma > 0$ there exists a superior limit $z = \lambda(+T - u_m)$ for z , corresponding to $u' = +\infty$, consequently a horizontal asymptote above.

From (10) we find

$$v - v' = \frac{(a+\tau)v' + \sigma}{-\tau v' + (a-\sigma)} - v' = \frac{\tau v'^2 + (\sigma + \tau)v' + \sigma}{-\tau v' + (a-\sigma)} = \frac{(v'+1)(\tau v' + \sigma)}{(a-\sigma)(\gamma v' + 1)}, \quad (14)$$

and so conclude that in the real domain $v - v'$ has the sign of $\tau v' + \sigma$.

When τ and σ are both positive, we have always $v' < v$ or $u' < u$, so that the erroneous curve (u', z) has for equal z a smaller u than the true straight line. The curve is as it were generated by shifting (and deforming) the true line to the left.

When σ and τ are both negative, we have everywhere $v' < v$ or $u' < u$, so that the erroneous curve (u', z) is as it were generated by shifting to the right.

When σ and τ have opposite signs, there is a real point, $v' = -\frac{\sigma}{\tau}$, for which $v' = v$ and consequently $u' = u$. Then the erroneous curve cuts the true straight line in a point $u' = u = \log \left(-\frac{\sigma}{\tau} \right) = A$.

When $\sigma > 0$ and $\tau < 0$, we have $u' < u$, or $v - v' > 0$, for $v' < -\frac{\sigma}{\tau}$, or $u' < A$. Then at the left of $u' = A$ the provisional curve (u', z) is on the left side of the true straight line and to the right of $u' = A$ it is on the right side of this line.

When $\sigma < 0$ and $\tau > 0$, we have $u' < u$, or $v - v' > 0$ or

$\tau v' + \sigma > 0$ for $v' > -\frac{\sigma}{\tau}$ or, $u' > A$. The disposition is then the inverse of that of the last case.

When $\sigma = 0$, or $\beta = 0$, we have $B = \infty$, $S = \infty$, $A = -\infty$. So, the left and lower asymptotes being at infinity, also the point of intersection A is at infinite distance to the left.

When $\tau = 0$ or $\gamma = 0$, we have $C = \infty$, $T = \infty$ and $A = \infty$. Now the right and upper asymptotes are at infinity, the point A being at infinite distance to the right.

We now consider the curvature and the point of inflexion. For this latter $\frac{d^2 z}{du'^2} = 0$ holds, or $-\gamma v'^2 + \beta = 0$, or $v' = \pm \sqrt{\frac{\beta}{\gamma}} = \sqrt{\frac{\sigma(a-\sigma)}{\tau(a+\tau)}}$.

The point of inflexion is real when σ and τ , the errors in x_o' and x_n' , have opposite signs.

When $\sigma > 0$, $\tau < 0$, or $\beta > 0$, $\gamma > 0$, we have $\frac{d^2 z}{du'^2} > 0$ for $v' < \sqrt{\frac{\beta}{\gamma}}$, so that left of the point of inflexion the curve is convex downward.

For the slope λ' of the inflexion tangent we find

$$\left(\frac{dz}{du'}\right)_{v'=\sqrt{\frac{\beta}{\gamma}}} = \lambda' = \frac{\lambda(1-\beta\gamma)\sqrt{\frac{\beta}{\gamma}}}{\left(\sqrt{\frac{\beta}{\gamma}+\beta}\right)\left(\gamma\sqrt{\frac{\beta}{\gamma}+1}\right)} = \lambda \frac{1-\sqrt{\beta\gamma}}{1+\sqrt{\beta\gamma}} < \lambda.$$

When $\sigma < 0$, $\tau > 0$, or $\beta < 0$, $\gamma < 0$, we have $\frac{d^2 z}{du'^2} > 0$ for $v' > \sqrt{\frac{\beta}{\gamma}}$, so that the curve is convex downward to the right of the point of inflexion.

To find the slope λ' of the inflexion tangent we put

$$\beta = -\beta_1, \quad \gamma = -\gamma_1;$$

and so obtain:

$$\left(\frac{dz}{du'}\right)_{v'=\sqrt{\frac{\beta}{\gamma}}} = \lambda' = \frac{\lambda(1-\beta_1\gamma_1)\sqrt{\frac{\beta_1}{\gamma_1}}}{\left(\sqrt{\frac{\beta_1}{\gamma_1}-\beta_1}\right)\left(-\gamma_1\sqrt{\frac{\beta_1}{\gamma_1}+1}\right)} = \lambda \frac{1+\sqrt{\beta_1\gamma_1}}{1-\sqrt{\beta_1\gamma_1}} = \lambda \frac{1+\sqrt{\beta\gamma}}{1-\sqrt{\beta\gamma}} > \lambda.$$

When $\sigma = 0$, or $\beta = 0$, the point of inflexion lies to the left at infinity and its inflexion asymptote is parallel with the true straight line.

When $\tau = 0$ or $\gamma = 0$, the point of inflexion lies to the right at

infinity and its inflexion asymptote is parallel with the true straight line.

After this preparatory study we may distinguish the following eight cases.

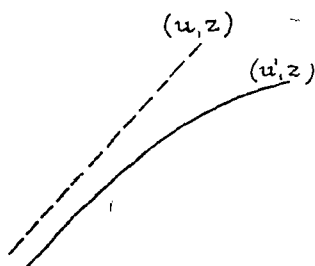

FIG. 2a.

1. x_o' right, x_n' too low ;
 i.e. $\sigma = 0, \tau < 0$, or $\beta = 0, \gamma > 0$;
 $\frac{d^2z}{du'^2} < 0$, $Lim \left(\frac{dz}{du'} \right)_{u' = -\infty} = \lambda$,

$$Lim \left(\frac{dz}{du'} \right)_{u' = +\infty} = 0.$$

$u' > u$ from $u' = -\infty$ to $u' = +\infty$.
 (fig. 2a).

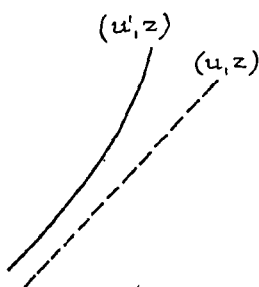

FIG. 2b

2. x_o' right, x_n' too high ;
 i.e. $\sigma = 0, \tau > 0$, or $\beta = 0, \gamma < 0$;
 $\frac{d^2z}{du'^2} > 0$, $Lim \left(\frac{dz}{du'} \right)_{u' = -\infty} = -\lambda$,

$$\left(\frac{dz}{du'} \right)_{u' = +C} = \infty.$$

$u' < u$ from $u' = -\infty$ to $u' = +C$
 (fig. 2b).

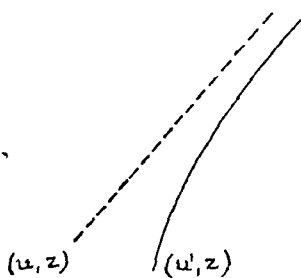

FIG. 2c

3. x_o' too low, x_n' right ;
 i.e. $\sigma < 0, \tau = 0$, or $\beta < 0, \gamma = 0$;
 $\frac{d^2z}{du'^2} < 0$, $\left(\frac{dz}{du'} \right)_{u' = -B} = \infty$,

$$Lim \left(\frac{dz}{du'} \right)_{u' = +\infty} = \lambda.$$

$u' > u$ from $u' = -B$ to $u' = +\infty$.
 (fig. 2c).

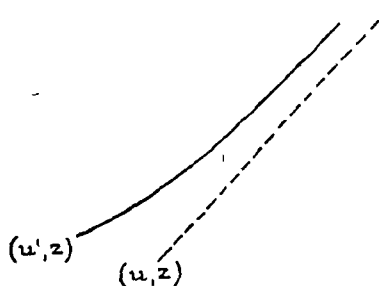

FIG. 2d.

4. x_o' too high, x_n' right ;
 i.e. $\sigma > 0, \tau = 0$, or $\beta > 0, \gamma = 0$;
 $\frac{d^2z}{du'^2} > 0$, $Lim \left(\frac{dz}{du'} \right)_{u' = -\infty} = 0$,

$$Lim \left(\frac{dz}{du'} \right)_{u' = +\infty} = \lambda.$$

$u' < u$ from $u' = -\infty$ to $u' = +\infty$.
 (fig. 2d).

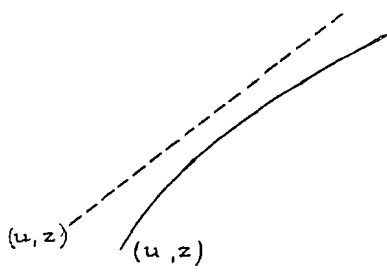

FIG. 2 e

5. x_o' too low, x_n' too low;
 i.e. $\sigma < 0, \tau < 0$, or $\beta < 0, \gamma > 0$;
 $\frac{d^2z}{du'^2} < 0, \left(\frac{dz}{du'}\right)_{u'=-B} = -\infty, -$
 $Lim\left(\frac{dz}{du'}\right)_{u'=+\infty} = 0.$
 $u' > u$ from $u' = -B$ to $u' = +\infty.$
 (fig. 2e)

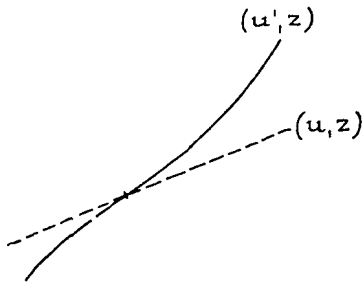

FIG. 2 f.

6. x_o' too low, x_n' too high;
 i.e. $\sigma < 0, \tau > 0$, or $\beta < 0, \gamma < 0$;
 $\frac{d^2z}{du'^2} < 0$ on the left, $\frac{d^2z}{du'^2} > 0$ on the right
 of the point of inflexion;
 $\left(\frac{dz}{du'}\right)_{u'=-B} = \infty, \left(\frac{dz}{du'}\right)_{u'=+C} = \infty.$
 $u' > u$ for $u' < A, u' < u$ for $u' > A.$
 (fig. 2f)

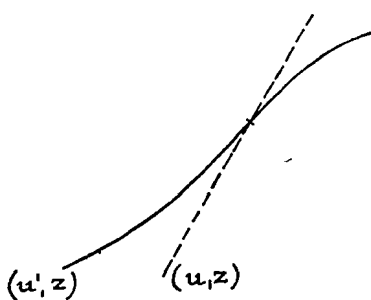

FIG. 2 g.

7. x_o' too high, x_n' too low;
 i.e. $\sigma > 0, \tau < 0$, or $\beta > 0, \gamma > 0$;
 $\frac{d^2z}{du'^2} > 0$ on the left, $\frac{d^2z}{du'^2} < 0$ on the right
 of the point of inflexion;
 $Lim\left(\frac{dz}{du'}\right)_{u'=-\infty} = 0, Lim\left(\frac{dz}{du'}\right)_{u'=+\infty} = 0.$
 $u' < u$ for $u' < A, u' > u$ for $u' > A.$
 (fig. 2g)

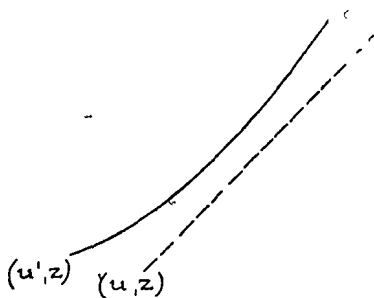

FIG 2 h

8. x_o' too high, x_n' too high;
 i.e. $\sigma > 0, \tau > 0$, or $\beta > 0, \gamma < 0$;
 $\frac{d^2z}{du'^2} > 0, Lim\left(\frac{dz}{du'}\right)_{u'=-\infty} = 0,$
 $\left(\frac{dz}{du'}\right)_{u'=+C} = \infty.$
 $u' < u$ from $u' = -\infty$ to $u' = +C.$
 (fig. 2h)

If in the cases 6 and 7 we have $\tau = -\sigma$, or $\gamma = \beta$, we find for the point of intersection A $v' = 1$ or $u' = 0$, hence $v = 1$ or $u = 0$. This point therefore coincides with the point of inflexion of the erroneous curve. This point of inflexion corresponding to $v = 1$ or $\frac{x-x_0}{x_n-x} = 1$ or $r = \frac{x_0+x_n}{2}$, it is conjugate to the point of inflexion of the original curve traced on ordinary squared paper.

$$6a. \quad \tau = -\sigma > 0 \text{ or } \beta = \gamma < 0 \\ \text{(fig. 3a)}$$

$$7a. \quad \tau = -\sigma < 0, \text{ or } \beta = \gamma > 0 \\ \text{(fig. 3b)}$$

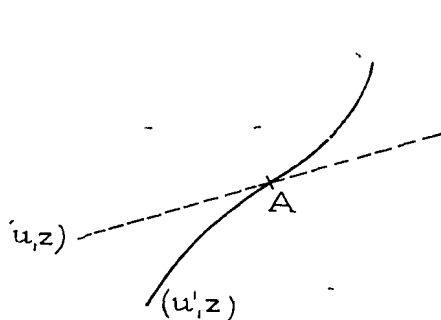

FIG 3a

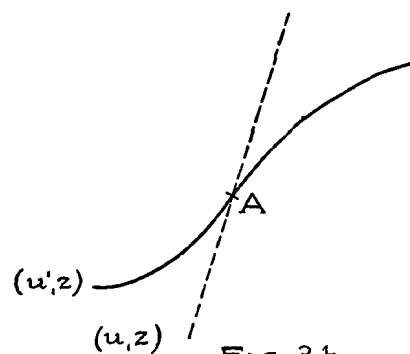

FIG. 3b

From (4) we find for the reaction-function

$$\eta = \frac{1}{f'(x)} = \frac{dx}{dz} = \frac{-x^2 + (x_0 + x_n)x - x_0 x_n}{\lambda M (x_n - x_0)} = -Px^2 + Qx + R.$$

the reaction consists of a (positive or negative) constant, of a (probably positive) term proportional to x and of a negative term proportional to x^2 .

Example.

Length of oat-stalks (data procured by Dr. E. GILTAY, Wageningen).
Unit of x : 1 cm.; class-range = 1 unit = 1 cm.

The following table contains the observed values of x with the corresponding numbers Y of individuals ($\Sigma Y = N = 1008$); moreover the values of z appertaining to the class-limits are given.

In the figure on ordinary squared paper the frequency-curve is represented by $x-x-x$, the normal function by $-$, the reaction-curve by $----$.

The figure on logarithmic paper contains the line $z = \lambda(u - u_m) = 3,36(u - \log 1,318) = 3,36u - 0,403$.

Since $x_n - \bar{x}$ (see p. 536) has an uncommonly small value, the formula (9a) is not suitable for the computation of α . Therefore we started by estimating $x_0 = 0$ and $x_n = 2\xi = 2 \times 47,5 = 95$, which

x	Y	z	x	Y	z	x	Y	z
25	2	- 2.035	45	28	- 0.502	65	22	+ 0.771
26	3	- 1.820	46	24	-0.449	66	20	+ 0.837
27	3	- 1.707	47	41	- 0.363	67	19	+ 0.910
28	1	- 1.675	48	25	- 0.314	68	18	+ 0.987
29	4	- 1.576	49	20	- 0.276	69	13	+ 1.052
30	5	- 1.485	50	30	- 0.220	70	22	+ 1.187
31	5	- 1.414	51	32	- 0.165	71	10	+ 1.266
32	6	- 1.343	52	30	- 0.108	72	7	+ 1.332
33	10	- 1.249	53	35	- 0.046	73	3	+ 1.364
34	6	- 1.202	54	32	+ 0.011	74	7	+ 1.456
35	11	- 1.126	55	47	+ 0.094	75	8	+ 1.598
36	7	- 1.085	56	37	+ 0.160	76	3	+ 1.670
37	11	- 1.026	57	42	+ 0.237	77	3	+ 1.777
38	16	- 0.951	58	24	+ 0.282	78	2	+ 1.875
39	17	- 0.882	59	32	+ 0.344	79	2	+ 2.035
40	22	- 0.803	60	41	+ 0.427	80	0	+ 2.035
41	20	- 0.740	61	34	+ 0.502	81	0	+ 2.035
42	23	- 0.673	62	33	+ 0.579	82	0	+ 2.035
43	11	- 0.643	63	29	+ 0.654	83	1	+ 2.185
44	30	- 0.567	64	18	+ 0.704	84	0	+ 2.185
45	28		65	22		85	1	

values appeared to be pretty satisfactory. Besides we found $x_m = 54$ and $\lambda = 3,36$. So the normal function runs:

$$z = 3,36 \cdot {}^{10}\log \left(\frac{x-0}{95-x} : \frac{54-0}{95-54} \right) = 3,36 \cdot {}^{10}\log \frac{x}{95-x} - 0,403.$$

The reaction-function is

$$\eta = 95x - x^2.$$

The elementary increment consists of a positive part proportional to the length already reached and of a negative part, corresponding to a shrinking, proportional to the 2nd power of the length. Supposing the growing stalk to retain the same shape, this stunting part is

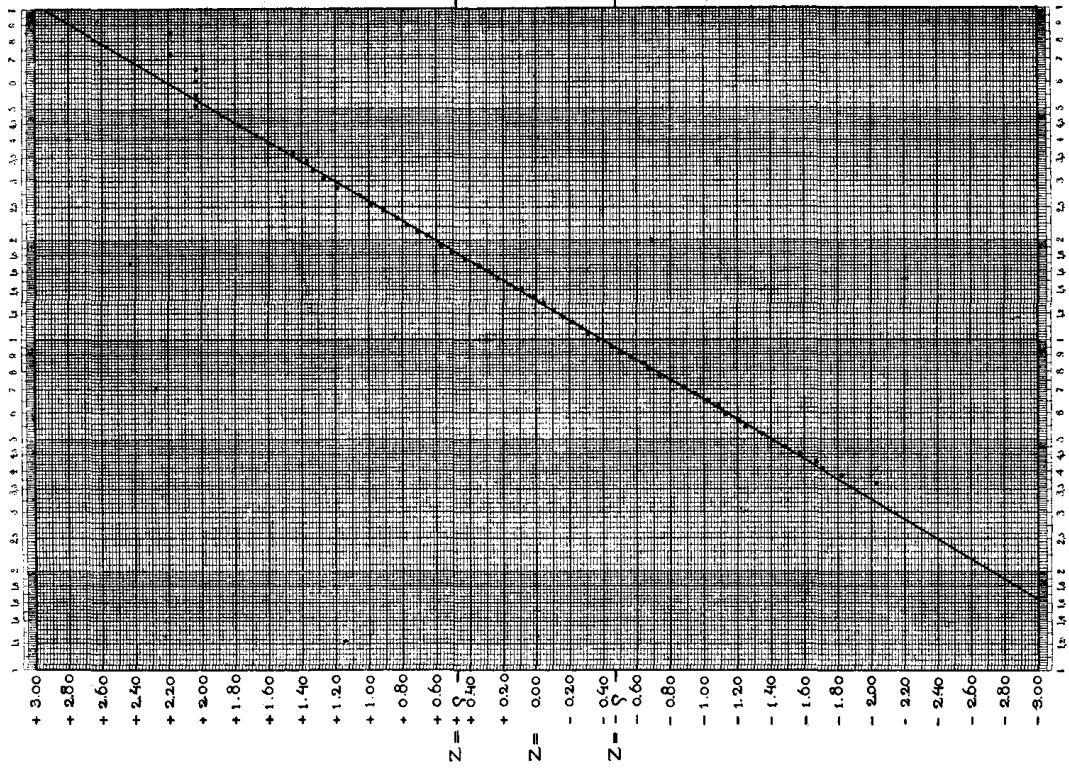
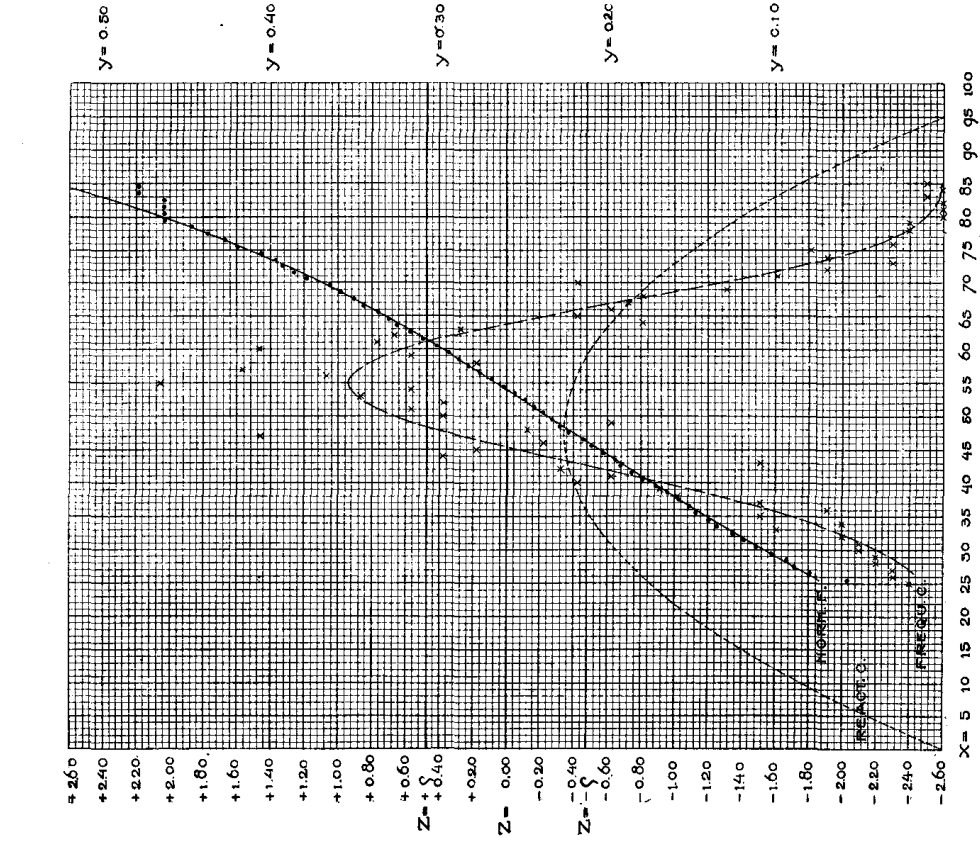

proportional to the surface. Thus we may say that the factors dependent on the 1st power of the length are preponderatingly favourable to growth, whereas those factors, which are connected with the surface, are chiefly disadvantageous.

Physics. — “*Note on P. SCHERRER’s calculation of the entropy-constant.*”¹⁾ By J. M. BURGERS. Supplement N^o. 41b to the Communications from the Physical Laboratory at Leiden. (Communicated by Prof. H. KAMERLINGH ONNES).

(Communicated in the meeting of Sept. 30, 1916).

The object of this note, which is suggested by a remark made by Dr. W. H. KEESOM, is to point out that:

(1). If a model of a monatomic gas constructed according to the theory of quanta on cooling at constant volume ceases to conform to the classical theory at temperatures which are too low (i.e. lower than is indicated by experiment), it will also give values for the entropy-constant which are too high, unless the entropy is not taken as zero at the absolute zero of temperatures for ideal gases

(2). The model suggested by SCHERRER remains ideal to temperatures far below the allowable limit.

§ 1. If for $T=0$ the entropy S is taken as 0, the absolute value of the entropy of one grammolecule of a gas for a given temperature T and a given volume V may be found by the following integration from 0 to T , the volume being kept constant at V ,

$$S = \int_0^T dT \frac{C_v}{T} \dots \dots \dots (1)$$

This integral may be divided into two parts as follows

$$S = \int_0^{T_0} dT \frac{C_v}{T} + \int_{T_0}^T dT \frac{C_r}{T} \dots \dots \dots (1^*)$$

and the temperature T_0 may be chosen such, that above T_0 the deviations from the ideal gaseous state are to be neglected. (In general T_0 will depend on the value of the volume; to begin with we will take as a special case $V=1$ cc.. For $V \geq 1$ cc. see below). The first part of equation (1¹) is certainly positive; we shall call

¹⁾ P. SCHERRER, Gött. Nachr. 1916.

it ε . In the second part, according to the supposition made, we have $C_v = \text{const.} = \frac{3}{2}R$ and therefore

$$S = \frac{3}{2}R \cdot \lg T - \frac{3}{2}R \cdot \lg T_0 + \varepsilon = \frac{3}{2}R \cdot \lg T + S_0 \dots (2)$$

For mercury-vapour the chemical constant is from 17 to 19 R ; from this fact it can be easily deduced that for a volume $V = 1$ cc., we must have $S_0 = \text{about } 3R$.

A lower limit of T_0 is found by taking $C_v = 0$ below T_0 , so that $\varepsilon = 0$, which gives

$$\begin{aligned} \lg T_0 &= \text{about } -2 \\ T_0 &= \text{about } 0.^\circ 1 \end{aligned}$$

In the gas-model given by SCHERRER T_0 is very much lower, it may be estimated at about 10^{-2} of a degree, as shown below.

This would give for S_0 the value: $41.5 R + \varepsilon$

and for the chemical constant: $57.2 R + \varepsilon$.

§ 2. Let us consider by what circumstances the said temperature is determined in SCHERRER's model. The equation of state corresponding to the model can be obtained by the wellknown method from the formula for the entropy, which SCHERRER derives from the value of the thermodynamic probability of the system. Except for a constant factor ¹⁾ this thermodynamic probability is completely determined by the number of elementary cells in the phase-space of the system, which lie inside the hyper-surface of constant energy. For large values of the energy, i.e. for high temperatures, this number may be calculated approximately by dividing the volume of an elementary cell into the volume enclosed by the energy-surface, the method also followed by SCHERRER; in this manner the equation of state of the ideal gas is obtained. It is therefore necessary to make an estimate of the possible error in this calculation for small values of the energy.

Both volumes, that enclosed by the energy-surface as well as that of an elementary cell, may be considered as a product of a volume in the space of coordinates and a volume in the space of momenta. The former is equal for both; the latter is a hyper-sphere for the energy-surface and a hyper-cube for the elementary cell. Taking $N = 6.15 \times 10^{23}$ and $h = 6.415 \times 10^{-27}$ it appears, that for one gram-molecule of mercury vapour of volume 1 cc. by assuming the energy to be $E = 1.055 \times 10^{-6}$ erg the radius of the hyper-sphere becomes six times the diagonal of an elementary cell, the ratio of the volumes in question being

$$Z = \text{about } 10^{25,8} 10^{23}.$$

¹⁾ A constant factor in W , i.e. an additive term in the entropy S , has naturally no influence on the equation of state.

An estimate of the uncertainty of this value is obtained by calculating the number of elementary cells which lie inside the hypercube inscribed in the energy-hypersphere. This number will be a lower limit for the quantity in question; it is equal to

$$(12) \quad 3N \approx \text{about } 10^{19,9 \cdot 10^{23}} \approx \text{about } Z^{0,77}.$$

The possible error in the thermodynamic probability, calculated from the ratio of the two volumes, is thus $Z^{0,23}$ at the most, from which it follows that that part of the entropy which depends on E may be incorrect by 23% at the most. It is clear, however, that this estimate of the error is very much-exaggerated, and also that the error diminishes rapidly on increasing E . If E is taken say 100 times larger, it would seem, that the deviations from the ideal gaseous condition may be neglected without scruple.

The limiting temperature T_0 corresponding to $E = 100 \times 1.055 \times \times 10^{-6} = 1.055 \times 10^{-4}$ is equal to 0.85×10^{-12} or rounded off

$$T_0 = 10^{-12} \text{ of a degree. } ^1)$$

§ 3. The cause of the gas-model remaining ideal at temperatures which are too low must be looked for in the small frequency of the vibrations. SCHERRER takes, as the periods in the quanta-formulae, times of the order of those required by a molecule to go backwards and forwards between the walls of the vessel. In order to obtain admissible values of the entropy-constant the following procedure suggested by Dr. KEESOM might be followed: each molecule is allowed the N^{th} part of the total volume as its "vibrational space"²⁾. If for the positional coordinates the original margin is retained, the elementary cell is then to be multiplied by N^{N^3} and the values of E_0 and T_0 by $N^{2/3} = 72 \times 10^{14}$, so that the contradiction with experiment ceases; S_0 becomes:

$$S_0 = -13,3 \cdot R + \varepsilon.$$

It is quite possible, that the value of ε is such, that S_0 in this equation obtains a suitable value of about $3R$ (see above § 1).

¹⁾ If the volume V is not 1 cc. the value of T_0 depends on V as follows

$$T_0(V) = T_0(1) \cdot V^{-2/3} = 10^{-12} \cdot V^{-2/3}$$

The entropy at temperature T and volume V is then given by:

$$S(T, V) = 3/2 \cdot R \cdot \lg T + R \cdot \lg V - 3/2 \cdot R \cdot \lg 10^{-12} + \varepsilon.$$

The ordinary entropy formula is thus obtained, although still with too large an additive constant.

²⁾ This means, that the time in which the mean distance between two molecules is described to and fro is taken as the time of vibration.

³⁾ If in SCHERRER's formula for the absolute value of the entropy the factor N^3 is omitted and replaced by N^2 , his entropy constant becomes smaller by R , and thereby agrees even better with the experimental values (l.c. p. 6).

Physics. — “*Note on the melting point of palladium and WIEN’s constant c_2 .*” By G. HOLST and E. OOSTERHUIS. (Communicated by H. KAMERLINGH ONNES.)

(Communicated in the meeting of March 25, 1916).

1. Recently E. WARBURG¹⁾ has published new rules for the standardizing of thermometers by the Physikalisch-technische Reichsanstalt at Berlin. In the notes appended, it is stated that the intensities of radiation of the black body at the melting point of palladium and that of gold for $\lambda = 0,6563 \mu$ are in the ratio of 81.5 to 1.

From WIEN’s radiation-formula it follows that:

$$\frac{\lambda}{M} \log_{10} \frac{E_{Pd\ mp}}{E_{Au\ mp}} = c_2 \left(\frac{1}{T_{Au\ mp}} - \frac{1}{T_{Pd\ mp}} \right) = L.$$

where $M = \log_{10} e$ and L is a constant.

It follows from the data given by WARBURG that $L = 2,8880$.

This constant may also be derived from measurements of other observers. W. W. COBLENTZ²⁾ has made a number of determinations of c_2 which are based on the melting points of palladium (1549), copper (1083), antimony (630.0) and zinc (419.2) as a scale of temperatures. All observers agree that on the scale which is fixed in this manner the melting point of gold lies at 1063°. Calculating L from his value of $c_2 = 14465$ and the melting points of palladium and gold, we find $L = 2\ 8880$.

In the *Astrophysical Journal*, Vol. 42, p. 300, 1915 E. P. HYDE, F. E. CADY, and W. E. FORSYTHE publish some measurements, from which L may again be derived. It follows from their results that at $\lambda = 0,6648 \mu$ $\frac{E_{Pd\ mp}}{E_{Au\ mp}} = 76,9$ and therefore $L = 2,8869$. The differences between these values for L may be explained by a deviation of the melting of palladium of only $\pm 0^\circ.25$. A better concordance, therefore, cannot be expected.³⁾

Whatever therefore the thermodynamic temperature of the melting point of palladium may be, it will always be necessary to assign a value to c_2 , such that

¹⁾ For instance *Ann. d. Phys.* (48), 1034, 1915.

²⁾ *Bull. Bur. of Stand.* (10), 76, 1914.

³⁾ Other series of observations (see F. HENNING, *Temperaturmessung* p. 240), also yield values for L which do not deviate much, with the exception of that of HOLBORN and VALENTINER, which is 2.7 % larger.

$$\left(\frac{1}{1236} - \frac{1}{T_{Pd_{smp}}} \right) c_2 = 2,888.$$

Sufficient attention has not always been paid to this relation. For instance in Circular 35 of the Bureau of Standards 2nd edition 1915 side by side with the melting point of palladium 1549° the value $c_2 = 14500$ is found. This would give $L = 2,895$, a value which is 0,25 % too high, whereas the experimental determinations do not differ from each other by more than 0,03 %.

I. LANGMUIR¹⁾ assumes $c_2 = 14392$. M. PIRANI²⁾ $c_2 = 14400$.

In consequence of this greater uncertainties arise than are necessary in view of the good agreement of the most recent measurements.

2. The above discussion naturally leads to a simple method of standardizing optical pyrometers, provided with colour-filters. The ratio v is measured of the intensities transmitted by the filter at the melting points of palladium and of gold. The effective wave-length may then be derived from

$$\lambda = \frac{LM}{\log v} = \frac{1,2542}{\log v}.$$

As an instance, if the red filter N°. F 4512 of SCHOTT and GEN. is taken about 5,8 mm. thick, and the effective wavelength between the two points is determined, the effective wave-length for other ranges of temperature may be derived from HYDE's calculations. In this manner a very simple method of standardising is obtained.

Summary:

To a given value of the melting point of palladium a definite value for c_2 corresponds.

If the melting point of palladium is taken as 1549° (scale of DAY and SOSMAN) c_2 must be taken equal to 14465 ± 5 . If on the other hand c_2 is taken 14300 (P.T.R. scale), it follows that the melting point of palladium is 1557°.

*Physical Laboratory of the N.V. Philips-
Incandescent-lamp-factories.*

¹⁾ Phys. Rev. (7) 153, 1915.

²⁾ Verh. D. phys. Ges. (17) 226, 1915.

Physiology. — "*The Electrical Phenomenon in Smell-mixtures*".

By Prof. Dr. H. ZWAARDEMAKER.

(Communicated in the meeting of September 30, 1916).

In ordinary life it has long been known that there are certain smells that neutralise each other. It is very difficult, however, to mix them experimentally in the right proportion to find the compensation-point i.e. the point at which they cancel each other completely. This is 1. because the constituents mostly volatilise unevenly (directly after the mixing because the solubility is mutually modified; later on through a difference of evaporation); 2. because the migrating odorous molecules generally diffuse with various rapidity; 3. because of the disproportionate adsorption of the smell-mixtures to the sides of phials, beakers etc., used in examining the mixture.

The difficulties to be obviated, are such as to render it next to impossible to find the compensation-point by mixing odorous fluids. In the perfume-industry and in pharmaceutical practice a moderate stability of the resultant odour should, therefore, be valued as a fairly satisfactory result.

The ascertainment of these proportions induced me, in the year 1888, to produce inodorousness by mixing the odorous gases themselves. Well-known, purely chemical odours were then combined in a double olfactometer made of metal, glass, and filter-paper. A surprisingly great number of complete compensations were achieved with it.

If one type were taken of each of the nine complemented classes of LINNAEUS' classification of smell qualities, numerical values could be established for $\frac{72}{9} = 36$ combinations¹⁾. Afterwards J. HERMANIDES²⁾ did the same in his thesis for a doctor's degree. With three combinations his results coincided with mine and with those of a third observer (HERINGA). Since then I examined terpineol, guaiacol and valerianic acid chiefly with these odours in paraffin solutions.

Much greater accuracy together with sufficient persistence can be secured, when replacing paraffin solutions by a saturated aqueous solution in which there is a slight excess of odorous matter. The olfactometer then contains a system of phases, viz. air, water, odorous matter, which after a few days will be equilibrated and which moreover maintains its equilibrium against the adsorption of the filter-paper.

¹⁾ H. ZWAARDEMAKER, ü. d. Proportionen der Geruchscompensation, Arch. f. Anat. u. Physiology. 1907, Suppl. p. 60.

²⁾ Utrecht 1909. See also Proc. Roy. Ac. Amst. May 29 1909. Vol. 18, p. 53.

It will be well though, to take caproic acid instead of valerianic acid, the latter being too soluble and also lowering the surface-tension to such an extent that in less than .10 time it spreads over all surfaces that are moist at all. The persistent adsorption largely encumbers the technical conduct of the experiments. Generally speaking adsorption is a serious impediment in odorimetry, whatever method may be followed. With caproic acid its influence is felt far less than with valerianic acid.

The stimulus limen of my olfactory organ is for terpineol at about 1 mm. of the cylinder-length; for guaiacol at about 2 mm.; for caproic acid at about 1 mm. on the double olfactometer just described. The terpineol limen corresponds with 4 micrograms per litre of air, that of guaiacol with $\frac{1}{20}$ microgram, that of caproic acid with $\frac{1}{200}$ microgram (1 microgram = 1.10^{-6} gram).

The odorometrical coefficients ¹⁾ of the saturated solutions are respectively 10, 5 and 10, i. e. the smell stimuli, evoked by means of the olfactometer and expressed in the centimeters to which the cylinders have been moved out, must be multiplied respectively by 10, 5 and 10 to ascertain the number of "olfacts" with which they correspond.

The compensation-point is arrived at when in the double olfactometer the odorous cylinders are pushed off the inhaling tubes over lengths that stand to each other:

for terpineol and guaiacol,	as 4 cm. to 5 cm.
„ „ „ caproic acid „	1 „ „ 3 „
„ guaiacol „ „ „	1 „ „ 1 „

A somewhat greater length of one odorous cylinder makes its smell come to the front and vice versa. Equilibrium is also found with multiples of the proportions, though a weak antagonism sometimes occurs.

When mixing in the same proportions the saturated solutions that are decanted off into a separator, we obtain mixtures none of which will be inodorous, as stated above. It is true, their scent is considerably weaker than that of the original concentrated solutions from which they have been derived. The odorimetrical coefficients proved to be:

for the terpineol-guaiacol liquid mixt.	3—4
„ „ „ -caproic acid „	2 $\frac{1}{2}$
„ „ guaiacol- „ „	2

all being obviously smaller than the coefficients found for each of the constituents (terpineol 10, guaiacol 5, caproic acid 10).

¹⁾ H. ZWAARDEMAKER, *Physiol. d. Geruchs*, Leipzig, 1895 p. 185.

The electrifying power¹⁾ on the other hand proved to be additive.

The maximal charge of the single solutions, determined by Mr. VAN DER BIJL²⁾ appears to be per c.c. of sprayed solution:

<i>Terpineol.</i>	<i>Guaiacol.</i>	<i>Caproic acid.</i>
$\frac{1}{2}$ sat. (too great)	$\frac{1}{2}$ sat. $135 \cdot 10^{-10}$ Coul.	$\frac{1}{2}$ sat. $196 \cdot 10^{-10}$ Coul.
$\frac{1}{4}$ „ $182 \cdot 10^{-10}$ Coul.	$\frac{1}{4}$ „ 57. „ „	$\frac{1}{4}$ „ 128. „ „

For the mixtures the charge per c.c. of sprayed solution is:

		Critical dist. (for 0.9 cc.)	Charge (per c.c.)
Terpineol-Guaiacol mixt.	(4 : 5)	60 c.m.	$168 \cdot 10^{-10}$ Coul.
Terpineol-Caproic acid mixt.	(1 : 2)	230 „	206. „ „
Guaiacol-Caproic acid mixt.	(1 : 1)	260 „	241. „ „

Regarding merely the odorous substances and neglecting the water the charge of the mixture would be too small; turning our attention to the water only and regarding the odorous substances merely as catalytic means, largely enhancing the initial ionization of the water, it would not be enough. The truth lies no doubt midway, since both the added odorous substances and the water are essential to bring about the electrical phenomenon, as measured by us.

But in whatever way the quantitative measurement may be carried out, the electrical phenomenon is at all events additive, whereas the olfactory quality appears to be weaker (weakened in the liquid mixture, faded out altogether in the mixture of the odorous gases in the double olfactometer).

From the foregoing it follows that in practice we are repeatedly confronted with fragrant matter of slight intensity, but of high electrifying power, when it is resolved in water and sprayed into a vapour. This will be the case, when it is built up of odorous substances which, when mixed, counteract each other in part, as to smell, but whose electrical effect is added together.

When the mixed substances pass into a chemical combination it

¹⁾ H. ZWAARDEMAKER, The Electrical Phenomenon in cloudlike condensed odorous Watervapours, examined in collaboration with Messrs H. KNOOPS and M. N. VAN DER BIJL, see These Proceedings Vol. XIX p. 44. The electrical phenomenon of odorous substances is allied to, but not identical with waterfall-electricity, for, apart from quantitative differences, our electrical phenomenon largely increases with a rise of temperature, whereas, according to LENARD, waterfall-electricity increases but little, and moreover the addition of salt augments vapour-electricity, whereas it diminishes true waterfall-electricity.

²⁾ All determinations were performed at an overpressure of two atm. with an earthed sprayer and at a critical distance. The latter was, with a spraying of 0.8 c.c. for $\frac{1}{2}$ dil. terpineol solution 4 c.c.; for $\frac{1}{2}$ dil. guaiacol solution 10 c.c.; for $\frac{1}{2}$ dil. caproic acid solution 13 c.c.

is a different matter. Take e.g. acetic acid and anilin, both of a rather high electrifying power; when they are combined to acetanilid (antifebrin) we get an odourless substance. Will it have electrifying power? To this question no a priori answer can be given, for the compound molecule as a whole and not the components from which it is derived, is answerable for the electrical phenomenon. Such a molecule, if electrifying at all, should satisfy the following conditions:

1. it should be soluble in water (substances insoluble in water do not give a charge).

2. it should lower the surface-tension of water, i. e. if a solid, it should yield the camphor-phenomenon.

3. it should volatilise from the aqueous solution, when spread over a large evaporation area.

The first and third conditions are fulfilled by acetanilid; experiments also show that it belongs to the remarkable group of organic substances, which like odorous substances produce the electrical phenomenon.

The three conditions just mentioned must be fulfilled in order to bring about an electrical phenomenon. Such substances may be odorous and *will* be so when moreover:

4. the substance is soluble in lipoid (*all* odorous substances are soluble in oil).

5. an odoriphore is present in the molecule.

The fourth condition is not or hardly satisfied by acetanilid; as to the fifth two groups of atoms are present in acetanilid that may be taken for odoriphores: 1. the aliphatic acid, 2. the anilin group.

RUPE and v. MAJEWSKI¹⁾ hold, however, that, when in one and the same molecule there are two odoriphores, a mutual counteraction may occur. This hypothesis and the slight solubility in oil account for the inodorousness of acetanilid. The same holds for other antipyretica (phenacetin, antipyrin, quinine). It is to be regretted that exceptions to such rules are never wanting.

All this leaves us still in the dark concerning the mysterious paralellism between smell, as a physiological, and vapour-electricity, as a physical property. This paralellism has thus far manifested itself for the vast majority of odorous substances:

a. in homologous series,

b. in the case of successive dilutions,

¹⁾ K. v. MAJEWSKI, Beitr. z. Kenntn. d. Diazo-imido-benzolderivate. Inaug. Diss. Basel 1898.

c. in the case of change of solubility and surface-tension through combining with salt- or sugar-solutions.

Divergencies are seen on either side. Some strong-smelling scents, moschus and scapol, set up a sensation even in dilutions, the electrifying power being next to none. With antipyretica on the contrary, the smell-intensity is all but inappreciable, the electrifying power very considerable. For an interpretation we must, in the present stage of our research, look to the five conditions, just mentioned, upon the fulfilment of which the properties depend. Maybe the study of the dielectric-constant will throw some more light on the subject in connection with A. COEHN's theory of contact-electricity, according to which the difference of potential, in the case of mutual contact of two substances is proportional to the difference of the dielectric constants ¹⁾. The differences between the dielectric-constants of odorous substances and those of water are generally very great, so that likewise we may look for great charges on numberless droplets, when odorous molecules accumulate on their surfaces in virtue of the fall of the surface-tension. The rapid evaporation from the measureless area makes these differences all the more probable, especially when a slight rise of the temperature increases the evaporation and the sprayer is placed at the proper distance from the intercepting screen.

Chemistry. -- "*The equilibrium solid-liquid-gas in binary systems which present mixed crystals*". (Fourth communication). By Prof. H. R. KRUYT. (Communicated by Prof. ERNST COHEN).

(Communicated in the meeting of September 30, 1916.)

I. In the former communication ²⁾ has been communicated a research of Dr. W. D. HELDERMAN and myself on the three-phase equilibrium solid-liquid-gas (S L G) in the system bromine-iodine. The three-phase line exhibited in its PT-projection two maxima and one minimum, a peculiarity which is closely connected with the appearance of the compound IBr. For the general knowledge of the binary systems it is not uninteresting to more closely consider these equilibria; all the more so because the appearance of two maxima and one minimum on the melting branch of a com-

¹⁾ A. COEHN u. U. RAYDT. Göttinger Nachrichte 1909 p. 263.

²⁾ Proc. Royal Ac. A'dam, Meeting, of June 1916.

pound is also possible when no formation of mixed-crystal takes place whatever. The mutual proportions, however, are very different there and, as we will notice below, the conditions for the appearance of these remarkable points are also different.

2. The general equation for the three-phase equilibrium in a binary system can, as is well-known ¹⁾, be written as follows.

$$T \frac{dP}{dT} = \frac{(x_S - x_L) Q_{GS} - (x_S - x_G) Q_{LS}}{(x_S - x_L) V_{GS} - (x_S - x_G) V_{LS}} \dots (1)$$

or

$$T \frac{dP}{dT} = \frac{Q_{GS} - \frac{x_S - x_G}{x_S - x_L} Q_{LS}}{V_{GS} - \frac{x_S - x_G}{x_S - x_L} V_{LS}} \dots (2)$$

in which the symbols with a double phase-index indicate respectively the heat and the change in volume when one gram-molecule of one phase is dissolved in an infinitely large quantity of the other, the external conditions being kept constant. Q_{GS} has, therefore, the order of a sublimation heat, Q_{LS} that of a melting heat. Hence Q_{GS} is usually a few times greater than Q_{LS} . Likewise V_{GS} is always greater than V_{LS} and this in the order of 10^4 times greater.

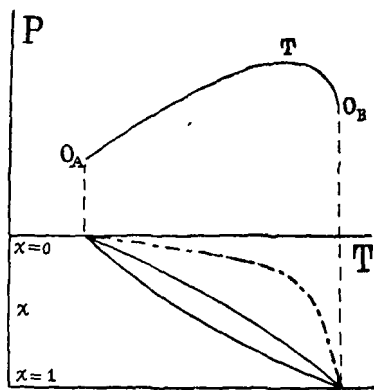

Fig. 1.

Let us now consider first a system with a continuous series of mixed crystals such as the system $p \text{ Cl}_2\text{C}_6\text{H}_4$ — $p \text{ Br}_2\text{C}_6\text{H}_4$ ²⁾, in which the three-phase line has a form as in fig. 1 when sketched as PT - and Tx -projection. We remember that for a maximum (or minimum) it is necessary that the numerator in the equation (2) should become zero and that for this it is required that

$$\frac{x_S - x_G}{x_S - x_L} = \frac{Q_{GS}}{Q_{LS}} \dots (3)$$

¹⁾ Compare VAN DER WAALS-KOHNSTAMM, *Lehrbuch der Thermodynamik* II p. 521 et seq. (Leipzig 1912).

²⁾ Comp. my communications I and II in these Proc. 1909, 537 and 1910, 206 also *Zeitschr. f. physik Chem.* **79**, 657 (1912).

Now it will be evident how the formula describes the course taken by the three-phaseline. For in the Tx -projection we notice that in OA $x_S = x_L = x_G$, and that starting from OA , the fraction $\frac{x_S - x_G}{x_S - x_L}$ gradually increases and thus the possibility exists that it attains to a value equal to $\frac{Q_{GS}}{Q_{LS}}$.

Then $\frac{dP}{dT} = 0$, the maximum is attained; $\frac{dP}{dT}$ then becomes negative and the line on the PT -projection falls to OB ¹⁾.

The question whether indeed a maximum occurs thus depends on the concentration ratios of the coexisting phases and those of the heat values. By means of another method we previously arrived at a similar result (see our first communication).

The three-phase line proceeds without a maximum or minimum if the component A which at each temperature has the highest vapour pressure, has a higher triplepoint temperature than B . $x_S - x_L$ is then continuously negative, which prevents the numerator from becoming zero. The impossibility of a maximum is moreover directly evident by looking at the spacial figure for that case.

3. In Fig. 2 the diagram (PT and Tx) is drawn for a system in which occurs a compound²⁾ on the melting branch of which in succession $x_S = x_L$, $x_S = x_G$ and $x_L = x_G$ is realised. In such case that branch exhibits also two maxima and one minimum. A further remarkable fact is the occurrence of a point towards $\frac{dP}{dT} = \infty$, and moreover the maximum point of sublimation and the

1) In the system $p\text{Cl}_2\text{C}_6\text{H}_4 - p\text{Br}_2\text{C}_6\text{H}_4$ the maximum lies at about 76° . If by interpolation we calculate the composition of the coexisting phases at that temperature we find approximately

$$\begin{aligned} x_S &= 0.94 \\ x_L &= 0.76 \\ x_G &= 0.27 \end{aligned}$$

from which follows

$$\frac{x_S - x_G}{x_S - x_L} = \frac{Q_{GS}}{Q_{LS}} = 3.7$$

which is a rather low value for that ratio.

2) For a detailed description of this class of three-phase lines compare v. D. WAALS⁴ KOHNSTAMM 1c; H. W. BAKHUIS ROOZEBOOM, These Proceedings 1905; G. II. LEOPOLD, Dissertation. Amsterdam 1906; A. SMITS, Zeitschr. f. physik. Chem. 78, 708 (1912).

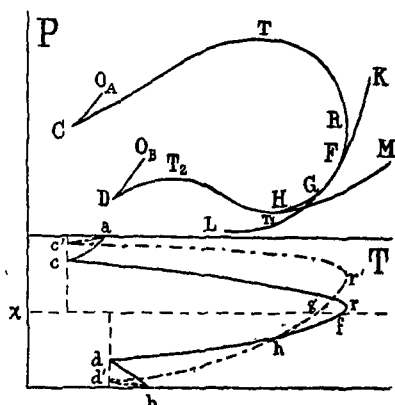

Fig. 2.

T_x-projection). The value for the maximum *T* is soon attained, then the numerator of equation 2 becomes negative. Just before *x_S* becomes = *x_L* (comp. equation 1)

$$(x_S - x_L) \Gamma_{GS} \text{ will become } = (x_S - x_G) \nu_{LS}$$

and, therefore $\frac{dP}{dT} = \infty$ (point *R*) for the concentration fraction approaches ∞ (when *x_S* = *x_L*) and so a value of about 10⁴ is once attained.

The numerator then has a great negative value, the denominator starts from *R*, also negative; hence $\frac{dP}{dT}$ positive. In *F* *x_L* = *x_S*;

the concentration fraction in equation (2) which before *F* is very largely positive, becomes very largely negative beyond *F*. This negative value declines until in *G* it has become 0, as in that point *x_G* = *x_S*. The concentration fraction now again assumes a rising positive value and in *H* it becomes 1 as in that point *x_G* = *x_L* and it will thus soon again attain a value causing

$$\frac{x_S - x_G}{x_S - x_L} = \frac{Q_{GS}}{Q_{LS}} \dots \dots \dots (3)$$

we then are in the minimum *T*. For if now we examine the *T_x* figure between *h* and *d* we readily notice that after the crossing of the *G*- and *L*-branch in *h* *x_S* - *x_G* increases much quicker in (negative) value than *x_S* - *x_L*; hence, the concentration fraction thus continues to rise at first, but in *dd'*, *x_L* and *x_G* do not usually differ much ¹⁾ as both are situated very close to the *B*-axis. Consequently the value of the concentration fraction has again begun to fall and once again the relation (3) has been satisfied, so causing the maximum *T* to appear. For the appearance of the minimum *T₁* and the

¹⁾ Much less than drawn in Fig. 2.

minimum melting point in which points the lines for the quasi-unary two-phase equilibrium compound + *L* and compound + *G* meet the three-phase line, respectively.

The connexion between this graphic representation of the three-phase equilibrium and the analytical expression used in § 2 has been worked out in the papers cited. On *CTF* the concentration fraction $\frac{x_S - x_G}{x_S - x_L}$

grows steadily greater (compare the

second maximum T_2 , the crossing at H and the appearance of a minimum pressure in the Px -sections of the system is, therefore, a necessity. ¹⁾

4. Now in the system Br-I also appear two maxima and one minimum, but in this system neither x_S becomes $= x_L$, nor $x_S = x_G$, nor $x_L = x_G$ at any temperature, as has been proved by the determinations of the melting and boiling curves by MEERUM TERWOGT ²⁾. Only, the differences $x_S - x_G$ and $x_S - x_L$ show and approach to

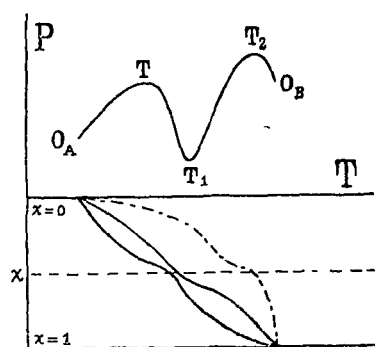

Fig. 3.

0 and this is sufficient to cause the appearance of the three marked points. For this we have only to examine Fig. 3, which indicates sketchily the proportions in the system Br-I in PT and Tx figure.

Starting in O_A the value of the concentration fraction $\frac{x_S - x_G}{x_S - x_L}$ will at first again increase and the value may become

equal to $\frac{Q_{GS}}{Q_{LS}}$, thus causing the maximum T to appear. As the numerator in equation (2) here becomes negative, the three-phase line will fall. This fall will be very pronounced, for the denominator of the concentration fraction decreases very strongly. For at about $x = 0.5$ the narrowing on the melting curve is very strong; it is, however, conceivable that the denominator in the second member of equation (2) will not turn to zero, for then the concentration fraction should assume the value 10000.

Meanwhile, not only the denominator of the concentration fraction assumes a small value, but the numerator will also decline particularly after the temperature has been passed at which the narrowing on the melting curve occurs. It is well known that vapour pressure ³⁾ or boiling diagrams of systems with a compound present a narrowing all the stronger when the dissociation is less. The boiling diagram ⁴⁾ of the system Br-I also exhibits such a narrowing, even at a temperature about 100° above that of the three-phase line. This narrowing

¹⁾ It is meanwhile evident that this relation is not necessarily decisive. For beyond H the concentration fraction must also attain the ratio of the caloric values (Consult the papers cited).

²⁾ Diss. A'dam 1904 and Zeitschr. f. anorgan. Chem. 47, 203 (1905).

³⁾ In this connexion see J. J. VAN LAAR, Zeitschr. f. physik. Chem. 47, 129 (1904).

⁴⁾ P. C. E. MEERUM TERWOGT, loc. cit.

in the Px -diagrams is strongest in the part of the figure at the side of the component with the smaller vapour tension¹⁾, hence at the iodine side. Whereas the numerator of the concentration fraction is now declining, its denominator gets larger when we have passed the narrowing in the melting diagram, favourable cooperation for allowing the value of the concentration fraction to rapidly fall again to that of $\frac{Q_{GS}}{Q_{LS}}$. The point T_1 will, therefore, be rapidly attained. Indeed it appeared in the research of Dr. HELDERMAN and myself that this point is attained at a temperature about 4° above the melting interval of the mixture $x_S = 0.50$ namely at $x_S =$ about 0.54. From the Tx side of figure 3 we can now readily read that the concentration fraction still continues to decrease but afterwards gradually rises again in consequence of the fact that $x_S - x_L$ decreases more rapidly than $x_S - x_G$. Hence, the possibility of a second maximum T_2 is created.

We will not discuss here any possible intermediate cases where a degeneration of maximum and minimum to points of inflection may take place. It will be quite evident now, that, where the narrowings are decisive for the appearance of the minimum, the above mentioned configuration occurs the more decidedly when the compound is less dissociated.

5. We will now 'call attention' to the difference in behaviour between a compound as explained by Fig. 2 and Fig. 3, that is to say between a dissociating compound and one miscible with its dissociation products in the solid condition. If such a compound without formation of mixed crystals is heated to fusion at a constant pressure the equilibrium will be quasi-unary²⁾, the compound has a sharp melting point. With the compound which forms mixed crystals such is not the case, for such a compound has a melting interval. In connexion therewith the equilibria at their own vapour tension, as read off from the PT -diagram are also more complicated.

First of all let us remember that in the point F of figure 2 $x_L = x_S$ and that consequently in equation (2) becomes $T \frac{dP}{dT} = \frac{Q_{LS}}{V_{LS}}$. This, however, is the equation for the melting line of the compound;

¹⁾ VAN LAAR, loc. cit.

²⁾ The expression *quasi unary*, *quasi binary* etc seems very appropriate for characterising the condition in which a system behaves as if it possesses one variable (or two, three etc.) less than indicated by the phase rule. (As to these equilibria see BAKHUIS ROOZEBOOM, Heterogene Gleichgewichte I pg. 34 and following).

that line is tangent therefore in F to the three-phase line and F is justly called the minimum melting point. Also in G $x_G = x_S$, hence $T \frac{dP}{dT} = \frac{Q_{GS}}{V_{GS}}$ and the sublimation curve of the compound is tangent here to the three-phase line. And in H $x_L = x_G$, hence

$$T \frac{dP}{dT} = \frac{Q_{GS} - Q_{LS}}{V_{GS} - V_{LS}} = \frac{V_{GL}}{Q_{GL}}$$

which involves the meeting of the three-phase line and the "line of the minima on the GL surface".

By these tangential contacts the PT -section at the composition of the compound gets the simple form of fig. 4¹⁾ $LGFK$ is a continuous curve

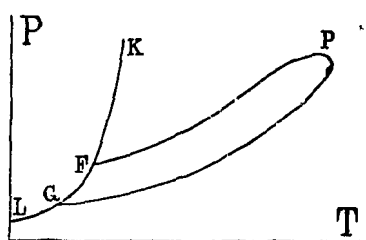

Fig. 4.

although LG is the quasi-unary sublimation curve, GF part of the three-phase line, and FK the quasi-unary melting line of the compound. FP and GP are demarcations for the complete condensation and evaporation, respectively. From a purely unary diagram, this figure is distinguished only by the fact that the triplepoint has grown to a range GF and the phenomena of the condensation and evaporation take place not at a single limit value, but also over an interval.

With a system of the type Br-I the difference with unary behaviour is much greater still. Because two phases nowhere attain the same composition, we miss the tangents at the three-phase line, in

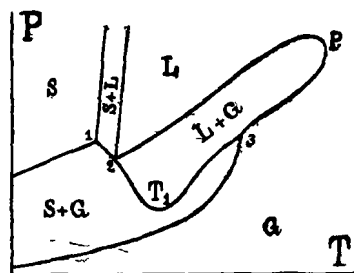

Fig. 5.

fact all lines for quasi-unary equilibrium get doubled to two streak limits. In Fig. 5 we notice the PT -condition diagram for the compound IBr and it may be readily deduced from the spacial figure (compare Fig. 5 of the third communication) or from our Fig. 3. It is

only *one possible* configuration; at the deduction it will be noticed that the mutual relations of the concentrations of coexisting phases decide the form of a figure such as Fig. 5. When following the section up from lower temperature we intersect first the region $S+G$. In point 1 the section for the first time meets the three-phase region, namely in the line indicating the composition of the mixed crystals. In point 2 the liquid branch

¹⁾ WURTE, Dissert Amsterdam 1909 p. 19.

F is in many respects comparable with point F in Fig. 2, also here a line FK for quasi-unary melting phenomena will appear ("line of the maxima" in the melting diagrams at different pressure values), hence we might call point F the "minimum quasi unary melting point" of the system. As starting from F $x_S - x_L$ has a negative value whereas $x_S - x_G$ remains positive; both numerator and denominator in equation (1) will also be negative; a further appearance of a maximum or a minimum is, therefore, excluded (compare § 2 last lines). Only when equalisation of phases takes place, (which involves a minimum in the Px -figure from $S-G$ or $G-L$ equilibria) further remarkable points would be possible, such as a "maximum quasi-unary sublimation point" a minimum and a maximum on the three-phase line etc.

The progressive change of these lines strongly reminds us of that of a compound without formation of mixed crystals but the configuration of Fig. 6 does not give us, however, an indication for the existence of a compound. On the contrary, an eventual decrease of the value $x_G - x_L$ which had such important consequences in § 4 does not affect any peculiarity on the three-phase line, not even a reduction of $x_G - x_L$ to zero in a maximum pressure would have that effect; only $x_G - x_L$ in a minimum would modify the line, but even then the doubt would remain whether we had to do with a chemical compound or not.

7. We must still refer in a few words to a system of the type d and l -carvoxim discussed in the previous communication. After the statement in § 6 it will be evident that the investigation of the three-phase line does not lead to a decision when the compound melts at a higher temperature than that of the components. But there is still another complication in a system of optic antipodes. It happens there that $x_G - x_L$ is zero at all concentrations. This is the case in the system d - and l - α -pipercolin¹⁾ albeit there occurs undoubtedly a solid racemic compound²⁾ in that system³⁾.

¹⁾ A. LADENBURG, Ber. deutsch. chem. Ges. **44**, 676 (1911); H. R. KRUYT, ibidem pg. 995.

²⁾ A. LADENBURG and SOBECKI, ibidem **43**, 2374 (1910).

³⁾ The fact that, in such a system, all G-L equilibria are quasi-unary is connected with the peculiar small differences of the components; a_1 is there undoubtedly $= a_2$, also $b_1 = b_2$; also a_{12} is evidently equal to a , for then $\frac{da_2}{dx} = 0$

and also $\frac{db_2}{dx} = 0$ and for

$$\left(\frac{\partial \psi}{\partial x} \right)_{VT}^G = \left(\frac{\partial \psi}{\partial x} \right)_{VT}^L$$

we can simply write then

In the system of the carvoxims it is sure to be the same case and then the equation of the three-phase line becomes

$$T \frac{dP}{dT} = \frac{Q_{GS} - Q_{LS}}{V_{GS} - V_{LS}} = \frac{Q_{GL}}{V_{GL}}$$

The three-phase line simply coincides with the vapour tension line for liquid carvoxim (whether *d*, *l*, *r* or a mixture) between the melting temperature of the components and that of the pseudo-racemic mixed crystal. This curve is then a double line and in a certain sense we might then say that it has one maximum which of course, is plainly noticed in the *Px*-projection.

But as to the decision between racemic compounds and pseudo-racemic mixed crystals this course of the three-phase line yields no criterion. Only, VAN LAAR ¹⁾ has pleaded for the conception that the form of the melting line of the carvoxims solely points to a compound, whereas TAMMANN ²⁾ on account of caloric values exactly arrives at the opposite result.

Utrecht, August 1916.

VAN 'T HOFF-Laboratory.

Chemistry. — “On Nitro-derivatives of Alkyltoluidines and the relation between their molecular refractions and those of similar compounds”. By Dr. J. D. JANSEN. (Communicated by Prof. P. VAN ROMBURGH).

(Communicated in the meeting of June 24, 1916).

Some years ago appeared a communication from HANTZSCH ³⁾ on chromoisomerism and homochromoisomerism of nitroanilines. In the conclusion of this remarkable publication, HANTZSCH says that yellow and orange di- and tri-nitroanilines, when their molecular refractions are abnormal, probably contain chromophores of different constitution. The *yellow* 3.4. dinitro-dimethyl-aniline and the *orange* 3.4. dinitro-diethyl-aniline, according to his opinion, are not *real*, but *pseudo*-homologues, which manifested itself in the molecular refractions,

$$mRTl \frac{x_G}{1 - x_G} = mRTl \frac{x_L}{1 - x_L}$$

or

$$x_G = x_L$$

The fact that $a_{12} = a_1$ certainly points out that in the liquid and vapour occur no (or at least *very* few) racemic molecules.

¹⁾ Zeitschr. f. physik. Chem. **64**, 289 (1908).

²⁾ Göttinger Nachrichten 1913.

³⁾ B **43**, 1662, (1910).

which did not differ double the refractive effect calculated by BRÜHL for the CH_2 group viz. 9.2, but only 7.8.

In order to indicate the difference between those pseudo-homologues HANTZSCH avails himself of subsidiary valencies.

As HANTZSCH stated he had obtained the 3.4. dinitro-dimethylaniline by the action of nitric acid (D. 1,3) on dimethylaniline, v. ROMBURGH¹⁾ supposed that for his experiments he did not use this substance, but 2.4. dinitro-*mono*-methyl-aniline. This supposition proved to be true, as indeed in the above mentioned reaction this substance was formed.

In connection with this mistake it appeared to me of some interest to test the theory of HANTZSCH, built by him on the investigation of these two and five more substances, to a far more extensive material. At the same time I wish to combine with this research an investigation concerning the nitration of dimethyl- and diethyl-*p*-toluidine, because in doing this I expected to obtain different substances, which with a great number of conformable nitroanilines, kindly put to my disposition by Prof. v. ROMBURGH, I might subject to a comparative refractometric research.

Nitro-derivatives of dimethyl-p-toluidine.

I prepared dimethyl-*p*-toluidine according to the method of STADEL²⁾. After having converted this, by nitration in conc. sulfuric acid, into 2. nitro-dimethyl-*p*-toluidine, I tried to nitrate this last substance further with diluted nitric acid.

To this end, I dissolved 3 grams of this product in 40 c.c. of nitric acid (D. 1,20) and added some sodium nitrite. Soon a pale yellow substance precipitated, showing the composition of a dinitro-tolyl-methyl-nitrosamine, which however proved to be a mixture of 2.3- and 2.5-dinitro-tolyl-methyl-nitrosamine. To prevent the formation of nitrosamines I decided to add urea.

7.5 Grams of 2 nitro-dimethyl-*p*-toluidine were added in little portions to 150 c.c. of nitric acid (D. 1,20) in which 0.5 gram of urea had been dissolved. Next day, the brownish-red liquid, which did not deposit a precipitate, is cautiously mixed with water. When about 150 c.c. had been added, an orange-brown substance began to separate slowly. This having been deposited, water was slowly

¹⁾ Proc. Roy. Akad. Amst. Jan. 28, 1911.

²⁾ B. 16, 29 (1883). If HBr-*p*-toluidine is heated with a surplus of methyl alcohol, then is produced as a bye-product the trimethyl-*p*-tolylammoniumbromide, beautiful colourless crystals, which decompose at about 225°.

added again and once more the solution gave a quantity of the same substance. On adding water to the filtrate this at first remained clear, but when about 150 c.c. had been added, a red substance precipitated. By the addition of more water, some more of this substance was obtained, while at last by neutralisation with soda a small quantity of the original product separated.

The red substance melted at 103° and appeared to be the already known 2,5-dinitro-dimethyl-p-toluidine. The orange brown substance, fairly soluble in boiling alcohol, melted at 87° . Seeing the analytical results I supposed I had to do with the still unknown 2,3-dinitro-dimethyl-p-toluidine. This proved to be the case indeed, as by oxidation with chromic acid it is converted into 2,3-dinitro-monomethyl-p-toluidine, described by PINNOW ¹⁾.

I also converted the 2,3-dinitro-dimethyl-p-toluidine into the 2,3-dinitro-tolyl-methyl-nitrosamine, by dissolving it in nitric acid (D 1.20) and by slowly adding sodium nitrite. The nitrosamine precipitated, which on being boiled with acetic acid changed into the 2,3-dinitro-methyl-p-toluidine melting at 159° .

If the 2,3-dinitro-dimethyl-p-toluidine is boiled for some time with ten parts of nitric acid (D. 1.49), then on pouring it out into water the already known 2,3,5 trinitro-4-tolyl-methyl-nitramine (m. p. 157°) precipitates.

As the 2,3-dinitro-dimethyl-p-toluidine contained two nitro-groups in ortho-position, I thought it might be of some interest to try to substitute one of them by interaction of ammonia and of different amines. For in this way, the ortho-position of the nitro-groups might be defined in another way than had been done by PINNOW (l. c.); at the same time might appear the degree of mobility of that nitro-group which was to be substituted.

It was to be expected, that the substitution of the nitro-group would not be easy. SOMMER ²⁾ had studied the action of ammonia and of different amines — aliphatic as well as aromatic — on 2,3,5-trinitro-methyl-p-toluidine and on the nitrosamine and nitramine derived from it and he had experienced that it is true that the nitro-group was substituted, whilst methylamine also acted on the nitramino-group, but that it was necessary in case of ammonia, methyl- and dimethyl-amine to work at 100° under pressure.

Therefore I heated 0.5 gram of 2,3 dinitro-dimethyl-p-toluidine with 5 c.c. of alcohol and 5 c.c. of ammonia (D. 0.91) for some

¹⁾ J. p. Chem. **62**, 505 (1900).

²⁾ J. p. Chem. **67**, 513 (1903).

hours in a press bottle in a water-bath. After cooling, the original compound crystallized. Also after heating with alcoholic solutions of methyl-, dimethyl- and ethyl-amine I could not state that the nitro-group had been acted upon.

Aniline also, which does act on the 2.3.5-trinitro-methyl-p-toluidine, did not act on the 2.3-dinitro-dimethyl-p-toluidine. Nor could amines act on the nitro-group of the 2.3 dinitro-mono-methyl-p-toluidine.

Thus the nitro-group (2) proves to be very closely united with the nucleus. SOMMER supposed this difficult substitution to be caused by "steric hindrance" by the neighbouring methyl-group.

In order to examine this I heated 0.5 gram of 2.3-dinitro-aniline with 5 c.c. of alcohol and 5 c.c. of ammonia (D. 0.91) for one hour in a press bottle in a water-bath. The compound proved unchanged.

From all those experiments it appears again that to define the structure, the rule of LAUBENHEIMER is only to be used with great reserve.

Nitro-derivatives of diethyl-p-toluidine.

I got 2-nitro-diethyl-p-toluidine according to ALFTHAN's method ¹⁾. If the nitrating liquid is poured out into a large quantity of iced water, so that the temperature remains below 25°, then nothing else separates but the mono-nitro-product, a red oil (b. p. 195° at 17 m.m.), even when a large surplus of nitric acid has been used. ALFTHAN, who also obtained higher nitrated products by this reaction, evidently had not kept the temperature low while pouring out into iced water.

When 2-nitro-diethyl-p-toluidine is boiled for some time with conc. nitric acid, then it changes into 2.3.5-trinitro-tolyl-ethyl-nitramine (m. p. 98°), a light yellow substance already described by ALFTHAN.

More easily is this nitramine to be obtained by nitrating mono-ethyl-p-toluidine, dissolved in conc. sulphuric acid at low temperature with a large quantity of conc. nitric acid ²⁾.

While keeping the temperature below 0° I dropped 8 c.c. of nitric acid (D. 1.49) dissolved in 20 c.c. of sulphuric acid into 10 c.c. of ethyl-p-toluidine dissolved in 110 c.c. of the same acid (D. 1.84). After some time I slowly added 100 c.c. of nitric acid (D. 1.49) — continually cooling the mass — and then left the liquid in a basin of water till next day. On pouring it out into ice the 2.3.5-trinitro-tolyl-ethyl-nitramine precipitated.

When this substance is boiled for six hours with phenol, amyl

¹⁾ Thèse, Genève (1909).

²⁾ VAN ROMBURGH & SCHEPERS, Proc. Roy. Akad. Amst. 369 (1913).

alcohol and some drops of conc sulphuric acid ¹⁾, then 2.3.5-trinitro-ethyl-p-toluidine, a yellow compound (m.p. 150°), is formed.

On nitrating diethyl-p-toluidine, dissolved in conc. sulphuric acid, with a quantity of nitric acid calculated for two nitro-groups and on afterwards pouring it out into four volumes of water, the temperature rising to about 50°, the red 2.5-dinitro-diethyl-p-toluidine is formed (m.p. 50°) the structure of which has been defined by ALFTHAN. However, if I poured it out into two volumes of water, the temperature now rising to 80°. a cloudiness with evolution of nitrous vapours suddenly manifested itself. A light red crystalline mass was slowly formed. This mass was treated with hydrochloric acid (D. 1,19); part of it dissolved and by dilution a red precipitation, the 2.5-dinitro-ethyl-p-toluidine (m.p. 105°), was formed in this solution.

That part which did not dissolve in hydrochloric acid was recrystallized from acetone and afterwards from alcohol and formed a light yellow compound, 2.5-dinitro-tolyl-ethyl-nitrosamine (m.p. 84°).

I could prove that the nitro-groups of the last mentioned compounds really take the places 2 and 5 by nitrosating the 2.5-dinitro-diethyl-p-toluidine.

On dissolving this substance in nitric acid (D. 1.2) and slowly adding sodium nitrite the above described nitrosamine (m. p. 84°) precipitates, which changes by boiling with acetic acid into the red 2.5-dinitro-ethyl-p-toluidine (m. p. 105°).

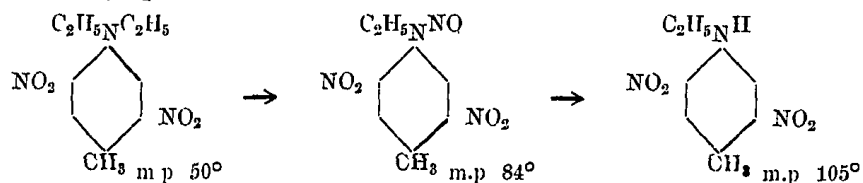

If the three above mentioned substances are boiled with nitric acid (D. 1.49), they change into the 2.3.5. trinitro-tolyl-ethyl-nitramine.

Nitro-derivatives of ethyl-o-toluidine.

I started from 4-nitro-ethyl-o-toluidine prepared by nitrating ethyl-o-toluidine in twenty times its weight of sulfuric acid. Like HANTZSCH ²⁾ I obtained it in *yellow* crystals and not as MAC CALLUM ³⁾ mentions in *light red* needles.

The latter reduced the nitro-group and got from the diamine, which had been formed, a chrysoidine by means of diazobenzene

¹⁾ SOMMER, J. p. Chem. **67**, 535 (1903).

²⁾ B **43**, 1673 (1910).

³⁾ J. Chem. Soc. **67**, 246 (1895).

chloride, thus proving the meta-position of the nitro- in relation to the amino-group. He assigned to the nitro-group place 4, though as a consequence of his research two structure-formulae were possible:

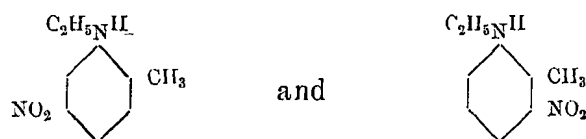

In order to prove that the first formula is the right one I ethylated 4-nitro-o-toluidine and got a yellow compound, identical with the nitro-ethyl-o-toluidine described above.

When the 4-nitro-ethyl-o-toluidine is boiled during some time with nitric acid (D. 1.49) an almost colourless compound (m. p. 112—113°) is formed, the analysis of which proves it to be a trinitro-o-tolyl-ethyl-nitramine.

The same substance is formed by nitrating ethyl-o-toluidine dissolved in conc. sulfuric acid with a large surplus of conc. nitric acid in the same way as described for the ethyl-p-toluidine. On pouring the liquid out on ice, which after having been left for one day, had become turbid by fine oil-like drops contained in it, the trinitro-o-tolyl-ethyl-nitramine precipitated. However if I left the liquid alone for several days, in some cases a crystalline mass was deposited therein, which proved to consist of the same almost colourless crystals.

As the ethyl-o-toluidine by nitration with nitric acid (D. 1.49) changes into the 3.5. dinitro-o-tolyl-ethyl-nitramine ¹⁾ we must assign to the nitro-groups of the new nitramine places 3, 4, and 5.

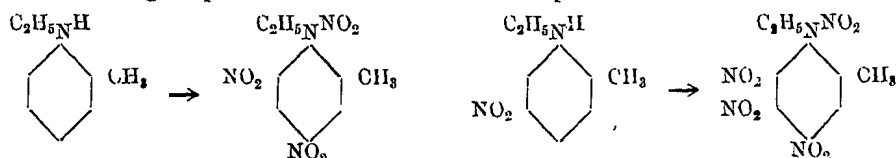

When the nitramine is boiled for some hours with phenol, amyl-alcohol and some drops of conc. sulphuric acid, the 3.4.5. trinitro-ethyl-o-toluidine is formed, which recrystallized from alcohol produces yellow needles melting at 150°.

Refractometric determinations.

After having dissolved the nitrocompounds in pyridine, the refractive indices for sodium light were measured with the refractometer of PULFRICH "Neuconstruction". Here follow some of the molecular refractions (M.-R.) measured by me ²⁾. The corresponding numbers

¹⁾ v. ROMBURGH. Rec. 3, 402 (1884).

²⁾ I have used the formula of LORENTZ LORENZ.

in the second list have been found by HANTZSCH; they refer to compounds of the *same* colour.

	M.-R.	Δ	M.-R.	Δ
2.4. dinitro-aniline	50,4			
2.4. dinitro-methyl-aniline	56,2			
2.4. dinitro-ethyl-aniline	61,2			
2.4. dinitro-dimethyl-aniline	61,1	9,4	62,2	9,5
2.4. dinitro-diethyl-aniline	70,5	9,8	71,7	9,4
2.4. dinitro-dipropyl-aniline	80,3		81,1	

The values found by me are somewhat smaller than those found by HANTZSCH. He used chloroform as a solvent, I used pyridine. The differences between the homologous members (indicated by Δ) are alike in the two series, if we take into consideration that the experimental errors become considerable in consequence of the high molecular weights. It is to be remarked that the molecular refractions of the dimethyl- and the ethyl-compound are the same.

We shall now pass on to the comparison of the other determinations by HANTZSCH with mine, the latter being placed in the first row.

	M.-R.	Δ	M.-R.	Δ
3.4. dinitro-dimethyl-aniline (yellow)	62,8	10,3	61,5	7,8
„ „ diethyl-aniline (orange)	73,1		69,3	
2.4.6. trinitro-dimethyl-aniline (y.)	65,7	9,3	63,1	8,1
„ „ diethyl-aniline (o.)	75,0	9,6	71,2	
„ „ dipropyl-aniline (o.)	84,6			

The results are very different for these homologues, which have *not* got the *same* colour. This is easy to explain for the 3.4. dinitro-dimethyl-aniline, because HANTZSCH did not use *this* substance, but the 2.4. dinitro-mono-methyl-aniline.

Except the already mentioned nitro-compounds I have still examined other homologues of the same as well as of different colours. For convenience' sake, I unite them all in two groups. First those having the same colour (yellow, orange, or red) and under them, those differing in colour.

	M.-R.	M.-R.	Δ
m-nitro-dimethyl- <i>and</i> -diethyl-aniline (o.)	48,5 and 58,2		9,7
p-nitro-dimethyl- <i>and</i> -diethyl-aniline (y.)	56,6 „ 67,2		10,6
2.4. dinitro-dimethyl- <i>and</i> -diethyl-aniline (y.)	61,1 „ 70,5		9,4
3.6. dinitro-dimethyl- <i>and</i> -diethyl-aniline (r.)	56,8 „ 65,3		8,5

	M.-R.	M.-R.	Δ
2 nitro-dimethyl- <i>and</i> -diethyl-toluidine (o.) . . .	53,1	and 62,1	9,0
2.5. dinitro-dimethyl- <i>and</i> -diethyl-toluidine (r.) .	61,4	„ 69,2	7,8
3.4. dinitro-dimethyl- (y.) <i>and</i> -diethyl-aniline (o.)	62,8	„ 73,1	10,3
2.4.6. trinitro-dimethyl- (y.) <i>and</i> -diethyl-aniline (o.)	65,7	„ 75,0	9,3
3.4.6. trinitro-dimethyl- (o.) <i>and</i> diethyl-aniline (y.)	68,2	„ 77,5	9,3

From these determinations it is clear that both with the homologues having the same colour and with those having different colours, the difference of the molecular refractions is sometimes far removed from that calculated by BRUHL (4,6 per CH₂ group).

Therefore in my opinion the refractometric determinations do not make me assume from the difference in colour of homologues that there is a difference in their subsidiary valencies.

This consideration caused me to carry on my research of molecular refractions in quite another direction.

Some years ago HANTZSCH¹⁾ had called attention to the fact that with the nitro- and aldehydephenols, as well as with their salts and also with the nitroanilines the orthocompounds have smaller molecular-refraction than the para ones.

Now I intended not only to test a number of mononitroanilines by the rule given by HANTZSCH, but also to seek among several aromatic nitro-compounds relations between the value of the molecular refraction, and the position of the groups united with the benzene-nucleus.

If really these relations existed, then for nitro-compounds the refractometer might be used as a welcome instrument to define their constitution.

The relation as stated by HANTZSCH between the value of the molecular refraction and the position of the nitro-group I could observe with a number of compounds.

	M.-R.	Δ	M.-R.	Δ
p-nitro-aniline	41,8	3,5	45,36	3,40
o-nitro-aniline	41,3		41,96	
m-nitro-aniline	38,7			

The numbers I found in pyridine-solution are somewhat lower than those found by HANTZSCH, who dissolved in acetone; however the differences are the same.

¹⁾ B. 43, 100 and 1656 (1910).

The same order ($p > o > m$) exists with the nitro-dimethyl- and diethyl-anilines and also in the nitro-toluidines.

	M-R.	M-R.
p-nitro-dimethyl- <i>and</i> -diethyl-aniline	56,6	and 67,2
o-nitro-dimethyl-aniline	48,9	
m-nitro-dimethyl- <i>and</i> -diethyl-aniline.	48,5	and 58,2
3. nitro-p-toluidine	M-R. = 46,7	
2. nitro-p-toluidine	M-R. = 43,2	

Relation between constitution and molecular-refraction proved to exist not only with the mono-nitro-anilines (toluidines), but also with those anilines (toluidines) which contained more than *one* nitro-group.

For instance: of the 3.4-, 2.4- and 3.6-dinitro-dimethyl (diethyl)-anilines, the first possessed the largest, the last the smallest molecular-refraction.

	M-R.	M-R.
3.4-dinitro-dimethyl- <i>and</i> -diethyl-aniline	62,8	and 73,1
2.4 " " " " "	61,1	" 70,5
3.6 " " " " "	56,8	" 65,3

The same order ($2.4 > 3.6$) exists with the methyl and ethyl-derivatives.

2.4-dinitro-methyl- <i>and</i> -ethyl-aniline	56,2	and 61,2
3.6. " " " " "	54,9	" 59,6

With the dinitro-p-toluidines the position 2.5 gives larger molecular refraction than 2.3.

2.5-dinitro-methyl- <i>and</i> -dimethyl-toluidine	60,2	and 61,4
2.3- " " " " "	58,2	" 59,6

The irregular behaviour of the 3.5- and 2.6-dinitro-toluidines must be mentioned here, because it contrasts with these regularities.

3.5-dinitro-toluidine and 3.5-dinitro-dimethyl-toluidine	55,0	and 58,8
2.6- " " " 2.6- " " "	49,6	" 59,8

With the trinitro-dimethyl (diethyl)-anilines I examined, the compounds with the nitro-groups in the position 3.4.6 showed larger molecular refraction than in 2.4.6.

3.4.6-trinitro-dimethyl- <i>and</i> -diethyl-aniline	68,2	and 77,5
2.4.6- " " " " "	65,7	" 75,0

On the strength of these determinations we may state that the molecular refraction of nitrated anilines and toluidines depends to a high degree on the position of the nitro-groups with respect to the amino-group.

Contrasting with these great *differences* in molecular refractions of isomeric nitro-anilines, we find that those of dinitro-benzenes and nitro-toluenes are practically *the same*.

1.4	Dinitro-benzene.	M-R. = 39,2	1.4.	Nitro-toluene.	M-R. = 38,1
1.2	„	„ = 38,8	1.2.	„	„ = 37,4
1.3	„	„ = 38,8	1.3	„	„ = 37,6

The explanation of this difference in properties between the two last-mentioned groups and the nitro-anilines and -toluidines is possible, when we take into consideration the light-absorption.

The absorptioncurves of several substances I used are known. All the nitro-anilines and nitro-toluidines have an absorption band — sometimes a very deep one — near the visible part of the spectrum, whereas in the dinitro-benzenes and nitro-toluenes this band has either disappeared or is situated a long way off, in the ultraviolet.

As an example may serve (λ in Ångstrom-units):

o-Nitro-aniline. ¹⁾ Shows a deep band ($\lambda \pm 4080$) and a shallow one ($\lambda \pm 2800$).

m-Nitro-aniline. ²⁾ Shows a band ($\lambda \pm 3700$).

p-Nitro-aniline. ²⁾ Shows a very deep band ($\lambda \pm 3840$).

The molecular refractions of these compounds are, as has already been stated, very different.

o-Nitro-toluene. ³⁾ Shows a band ($\lambda \pm 2450$).

m-Nitro-toluene. ³⁾ „ „ „ ($\lambda \pm 2630$).

p-Nitro-toluene. ³⁾ „ „ „ ($\lambda \pm 2780$).

The molecular refractions are almost equal.

o-Dinitro-benzene. ⁴⁾ Shows no band between $\lambda 4000$ and $\lambda 2000$.

m-Dinitro-benzene ⁴⁾ Shows no band.

p-Dinitro-benzene. ⁴⁾ Shows a band ($\lambda \pm 2560$).

Also with the following, nearly *colourless*, compounds having no absorptionband in the visible part of the spectrum, the isomerides have almost *similar* molecular refraction.

o-Xylene ⁵⁾	M-R. = 35,74	o-Toluidine ⁵⁾	M-R. = 35,33
m-Xylene	„ 35,90	m-Toluidine	„ 35,33
p-Xylene	„ 35,95	p-Toluidine	„ 35,95

¹⁾ PURVIS and Mc. CLELLAND. J. Chem. Soc. **103**, 1104 (1913).

²⁾ DALY, TUCK and MARSDEN, „ „ „ **97**, 582 (1910).

³⁾ „ „ „ „ „ „ „ 572 „

⁴⁾ PURVIS and Mc. CLELLAND, „ „ „ **103**, 1100 (1913).

⁵⁾ LANDOLT BORNSTEIN p 1032 and 1033 (1912).

o-Cresol ¹⁾	M-R _z = 32,52	o-Chloraniline ²⁾	M-R. = 35,46
m-Cresol	„ 32,56	m-Chloraniline	„ 35,55
p-Cresol	„ 32,57		

The molecular refractions of isomeric compounds are almost the same, if the absorption bands are situated far outside the visible part of the spectrum.

If however these bands are situated very near to or in the visible part of the spectrum, as is the case with all nitro-anilines and -toluidines examined so far, then the molecular refractions show great differences.

So it is evident that in the last mentioned substances the value of the molecular-refraction depends on the presence of absorption bands in the neighbourhood of the kind of light chosen for the determination of the refraction

In connection with this we call attention to the molecular refractions of the 2.3- and 2.5-dinitro-dimethyl-p-toluidine and the respective nitrosamines.

2.3. Dinitro-dimethyl-p-toluidine.	M-R. = 59,6	} $\Delta = 1,8$
2.5. „ „ „ „	„ 61,4	
2.3. Dinitro-tolyl-methyl-nitrosamine.	„ 56,9	} $\Delta = 0,5$
2.5. „ „ „ „	„ 57,4	

The difference in molecular refraction of the two strongly coloured dinitro-dimethyl-p-toluidines has almost disappeared, after substitution of a NO-group for a CH₃ group, in consequence of which almost colourless nitrosamines are formed.

Besides the molecular refractions of these nitrosamines are much smaller than those of the dimethyl compounds.

A careful examination of the molecular-refraction and absorption curve brings the following relations to light.

As has already been observed the molecular refraction is to a high degree dependent on the position of the nitro-group with respect to the amino-group. If we arrange isomerides according to the value of their molecular refractions and if we act in like manner with the homologues of these isomerides, then in both cases we get the same succession save a single exception which is easy to explain. Thus we have:

M.-R. of p-nitro-aniline	>	M.-R. of m-nitro-aniline.
M.-R. of p-nitro-dimethyl-aniline	>	M.-R. of m-nitro-dimethyl-aniline.

¹⁾ EYKMAN, Rec. 12, 177 (1893).

²⁾ See note 5 p. 573

This phenomenon is to be explained by observing the absorption curves (fig. I)¹⁾, the curves of the two para-derivatives, which are

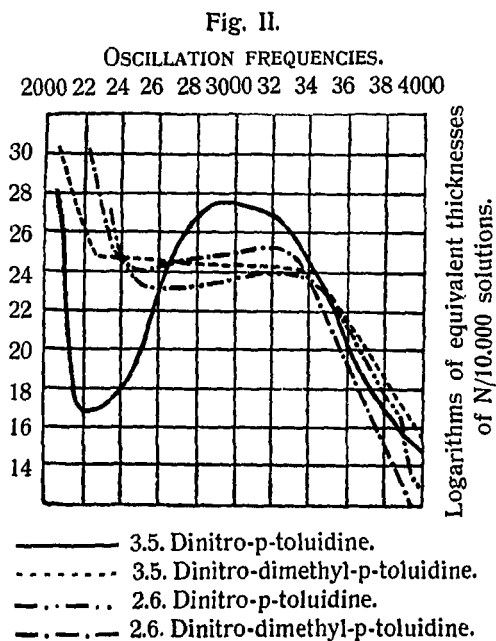
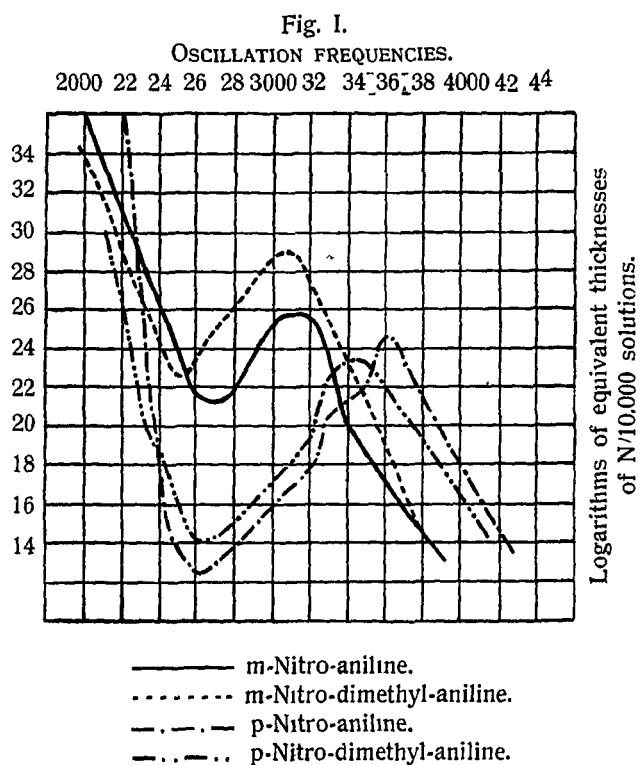

¹⁾ Baly, Tuck, and Marsden, J. Chem. Soc. 97, 582 (1910).

nearly similar, vary greatly from the curves of the two meta-derivatives, which are also nearly similar.

The molecular refraction of the p-nitro-aniline, the absorption band of which is much deeper and lies nearer to the yellow, is larger than that of the m-nitro-aniline.

The 3.5- and 2.6-dinitro-p-toluidines and their dimethyl-derivatives behave very irregularly. Here we have an example of the above mentioned exception.

	M.R.	M.R.	Δ
3.5-dinitro-toluidine and 3.5-dinitro-dimethyl-toluidine	55,0	and 58,8	3,8
2.6. „ „ „ 2.6. „ „ „	49,6	„ 59,8	10,2

A look at the absorption curves (fig. II)¹⁾ explains this behaviour. The curves of the two 2.6-dinitro-derivatives are almost similar, whereas those of the 3.5-dinitro-compounds diverge greatly. The molecular refraction of the 3.5-dinitro-p-toluidine, which possesses a deep absorption band, differs very little from that of its dimethyl derivative (3,8); this is in perfect accordance with the well-known fact that on the red side of a deep absorption band the refractive index is raised (anomalous dispersion).

Utrecht.

Org. Chem. Univ. Lab.

Physics. — “On adiabatic changes of a system in connection with the quantum theory.” By Prof. Dr. P. EHRENFEST. (Communicated by Prof. H. A. LORENTZ).

(Communicated in the meeting of June 24, 1916).

Introduction. In an increasing number of physical problems the foundations of classical mechanics (and electrodynamics) are used together with the quantum hypothesis, which is in contradiction with them. It remains of course desirable to come here to some general point of view from which each time the limit between the “classic” and the “quantum” region may be drawn.

WIEN’s law has been found by an application of classic principles: the changes of the distribution of the energy over the spectrum and the work done by a reversible adiabatic compression are calculated quite according to classic electrodynamics. This law derived without the use of quanta stands unshaken amid the quantum theory. This fact now is worth our attention.

Perhaps something similar holds in more general cases, when no longer harmonic vibrations take place, but more general motions:

¹⁾ MORGAN, JOBLING, and BARNETT, J. Chem. Soc. **101**, 1211 (1912).

the *reversible-adiabatic* changes for such more general motions might e.g. be calculated by the classic method, while in the calculation of *other changes* (e.g. of the isothermal addition of heat) the quanta already play a role.

This was the starting-point in some papers in which partly PLANCK's hypothesis of the energy steps ($\varepsilon = nh\nu$) was investigated in details¹⁾ and partly its generalization from harmonic to more general motions was treated²⁾. Especially the following hypothesis was used, to which EINSTEIN gave the name of *adiabatic hypothesis*³⁾.

"*Adiabatic hypothesis*"⁴⁾ If a system is exposed to adiabatic influences the "admissible" motions are transformed into "admissible" ones.

Let us suppose for some class of motions the quantum hypothesis to be introduced for the first time. In some cases the adiabatic hypothesis quite determines which special motions are "admissible": namely in the case that the new motion can be derived from a former class of motions by a reversible adiabatic process, for which has been fixed already, which special motions are "admissible" (especially therefore if the new motions can be obtained from harmonic motions with one degree of liberty").⁵⁾

In other cases the adiabatic hypothesis puts at least limits to the arbitrary way in which otherwise the quantum hypothesis might be applied.

In each such application of the adiabatic law a great part is played by the "*adiabatic invariants*", viz. those quantities which before and after the adiabatic process have the same value. Formerly there has been shown especially that for arbitrary periodic motions (of one or more degrees of liberty) there exists the adiabatic invariant:

$$\frac{\overline{2T}}{\nu} \dots \dots \dots (1)$$

1) P. EHRENFEST. Welche Züge der Lichtquantenhypothese spielen in der Theorie d. Wärmestrahlung eine wesentliche Rolle? Ann. d. Phys. 36 (1911) p. 91—118. [Further cited as communication A].

2) P. EHRENFEST, Bemerk. betr. d. Spezif. Wärme zweiatomiger Gase. Verh. d. deutsch. phys. Ges. 15 (1913) p. 451. [Comm. B]. — P. EHRENFEST. Een mechan. theorema van BOLTZMANN en zijne betrekking tot de quanten-theorie. Versl. Amsterdam. XXII (1913) p. 586. [Comm. C].

3) A. EINSTEIN. Beiträge z. Quantentheorie. Verh. d. deutsch. phys. Ges. 16 (1914) p. 826.

4) For the definition of the expressions used here comp. § 1, 2.

5) Comp. the transformation used in C § 3 of infinitesimal vibrations in uniform rotation, for other examples see §§ 7, 8 of this paper.

6) Comm. B § 1.

(ν is the frequency, T the mean value of the kinetic energy with respect to the time), which in the special case of harmonic vibrations of one degree of liberty coincides with ¹⁾):

$$\frac{\epsilon}{\nu} \dots \dots \dots (2)$$

The purpose of the considerations in this paper is:

1. To formulate the adiabatic law as sharply as possible, at the same time indicating where this sharpness is failing especially with respect to non-periodic motions.

2. To indicate what great significance must be ascribed to the "adiabatic invariants" in the quantum theory. The discussion of the above mentioned invariant $\frac{2T}{\nu}$ especially will show how it forms a link between the adiabatic hypothesis on the one hand and the quantum hypothesis of PLANCK, DEBIJE, BOHR, SOMMERFELD on the other hand.

3. To point out difficulties, which rise at the application of the adiabatic hypothesis, as soon as the adiabatic reversible changes lead through singular motions.

4. To show at least how the adiabatic problems are connected with the statistical mechanical bases of the second law of thermodynamics. The statistical mechanical explanation BOLTZMANN gave of it rests on statistical foundations which are destroyed by the introduction of the quanta.

Since then a statistical deduction has been given of the second law for some special systems (e.g. for those with harmonic vibrations) but not for more general systems ²⁾.

Hoping that others may succeed in removing the difficulties I was not able to surmount, I will publish my considerations.

Perhaps a close investigation will show that the adiabatic law may not be maintained in general. At all events W. WIEN's law seems to show that in the quantum theory a special place is taken by the reversible, adiabatic processes; that for them the classic foundations can be of most use.

§ 1 *Definition of the reversible adiabatic influence on a system. Adiabatic related motions: $\beta(\alpha)$ and $\beta(\alpha')$.*

¹⁾ See A § 2, C § 2. The existence of this adiabatic invariant may be considered as the root of WIEN's law.

²⁾ Comp. P. EHRENFEST. Zum BOLTZMANN'schen Entropie-Wahrsch Theorem. Phys Zschr. 15 (1914) p. 657 and § 8 of this paper.

Let q_1, \dots, q_n be the coordinates of a system, while the potential energy depends not only on the coordinates q , but also on certain "slowly changing parameters" a_1, a_2, \dots . Suppose the kinetic energy T to be a homogeneous quadratic function of the velocities $\dot{q}_1, \dots, \dot{q}_n$, while in its coefficients there occur besides the q_1, q_2, \dots eventually also the a_1, a_2, \dots . Some original motion $\beta(a)$ can be transformed into a definite other motion $\beta(a')$ by an infinitesimal slow change of the parameters from the values a_1, a_2, \dots to the values a'_1, a'_2, \dots . This special way of influencing the system may be termed "reversible adiabatic", the motions $\beta(a)$ and $\beta(a')$ "*adiabatically related*".

Remarks: A. The addition "reversible" needs no further justification, if all motions that are considered are periodic. It becomes different if under the considered motions there are aperiodic ones as e.g. the motion in a hyperbola under the attraction according to NEWTON'S law. Here the addition loses its original meaning. By the introduction of well-chosen coordinates, quasi-periodic motions as e.g. the oscillations of a conical pendulum or irrational motions of LISSAJOUS may be treated as periodic ones.

B. The definition given above needs generalization if the influence of a magnetic field has to be considered (ZEFMAN-effect) or if we have to do with an electro-magnetic system (reversible, adiabatic compression of radiation by a mirror).

§ 2. *Formulation of the adiabatic hypothesis for systems with periodic or quasi-periodic motions.*

Let the values a_{10}, a_{20}, \dots of the parameters if the system be determined in any way. The quantum theory will not allow every motion $B(a_0)$, which can exist with these parameter values according to the fundamental equations of mechanics, but only some of them ¹⁾. Therefore we speak of the motions $B\{a_0\}$ as "admissible" for the parameter values a_{10}, a_{20}, \dots . To another set of values of the parameters a_1, a_2, \dots there belong then "admissible" motions $B\{a\}$

Now the adiabatic hypothesis may be formulated as follows;

For a general set of parameter values a_1, a_2, \dots only those motions are possible that are adiabatically related with motions possible for the special values a_{10}, a_{20}, \dots (that is which can pass into these by a reversible change).

Remarks: A. Because of some difficulties rising in that question,

¹⁾ In order to avoid too many details, we leave aside that in PLANCK'S recent treatment of the theory of radiation only "critical" motions are considered, besides which also the other motions are "admissible". It is obvious how our discussion might be adapted to this new treatment.

(comp. § 9) I am not able to say whether the adiabatic law might be generalized to the real aperiodic motions and how this would have to be done.

B. Some forms of adiabatic influence may be realized without difficulties, e.g. the increase of an electric or magnetic field in the neighbourhood of an atom (STARK and ZEEMAN effect). Some others are more fictitious e.g. the change of a central force, (comp. § 7).

At all events from the example of WIEN's law it is evident, that such a fiction may show the right way. Only further investigation and the control by experiment can teach where the "natural" adiabatic influencing becomes "unnatural". At any rate the adiabatic law gives a statement that is the more positive the more multiple influencing we allow.

§ 3. *The adiabatic invariants and their application.*

Every use of the adiabatic proposition induces us to seek for "adiabatic invariants", viz. quantities which remain constant at the change of a motion $\beta(\alpha)$ into an adiabatically related motion $\beta(\alpha')$. From the adiabatic proposition namely the following conclusion may be immediately drawn.

If we assume that for the admissible motions $B(\alpha_0)$ a definite adiabatic invariant Ω has the discrete numerical values Ω', Ω'' for the special values $\alpha_{10}, \alpha_{20}, \dots$, then it has exactly the same values for the admissible motions belonging to the arbitrary values of the parameters α_1, α_2 .

§ 4. *The adiabatic invariant $\frac{\overline{2T}}{\nu}$ for periodic motions and $\frac{\epsilon}{\nu}$ especially for harmonic motions.¹⁾*

Let us suppose that the considered system has the following properties: For fixed but arbitrarily chosen values of the parameters $\alpha_1, \alpha_2, \dots$ all motions of the systems that have to be considered, are periodic, for any phase $(q_{10}, \dots, q_{n0}, \dot{q}_{10}, \dots, \dot{q}_{n0})$ the motion

¹⁾ Comp. communication C §§ 1, 2. *Other examples of adiabatic invariants* are the cyclic moments, if the system has cyclic coordinates. If the rotation of a ring of electrons is influenced by an increasing magnetic field, this is the sum of its moment of momentum and its electro kinetic moment (ZEEMAN-effect, magnetization). If an increasing electric field acts on a hydrogen atom of BOHR, then it is the moment of momentum with respect to the direction of the lines of force. At the change of the field of a central force (comp § 7) it is the moment of momentum.

may begin with. Here the period P may still depend in any way on a_1, a_2, \dots and on the beginning phase of the motion.

Then the time integral of the (double) kinetic energy taken over the period is an adiabatic invariant:

$$\delta' \int_0^P dt 2T = 0 \quad (3)$$

δ' will denote: the difference in the values for two infinitely near, adiabatically related motions of the system. [For the proof of (3) see appendix I]. If the reciprocal value of the period P is called the frequency ν and the mean with respect to the time of T \overline{T} , then (3) says:

$$\frac{2\overline{T}}{\nu} \text{ is an adiabatic invariant } (4)$$

In the case of a harmonic vibration of one degree of liberty the means with respect to the time of kinetic and potential energy are known to be equal to each other and therefore also to half the total energy, so that:

$$\frac{\epsilon}{\nu} \text{ is an adiabatic invariant. } (5)$$

§ 5. *A geometrical interpretation of the adiabatic $\frac{2\overline{T}}{\nu}$ in the (q,p) space. Connection with a theorem of P. HERTZ.*

In order to find a connection with the quantum hypotheses of PLANCK, DEBIJE, BOHR and others we shall use a deduction of the integral of action to which SOMMERFELD has drawn the attention.¹⁾

$$\int_0^P dt 2T = \int_0^P dt \sum_1^n p_h \dot{q}_h = \sum_1^n \int dq_h \cdot p_h = \sum_1^n \iint dq_h dp_h. \quad . (6)$$

therefore

$$\frac{2\overline{T}}{\nu} = \sum_1^n \iint dq_h dp_h. \quad (7)$$

where the double integrals on the right hand side have the following meaning: If the system executes its periodic motion, its phase point

¹⁾ A. SOMMERFELD: Zur Theorie d. Balmer'schen Serie, Sitzber. d. Bayr. Akad. 1916 p. 425 (§ 7).

describes a closed ¹⁾ curve in the $2n$ dimensional (q, p) space and its n projections on the 2 dimensional planes $(q_1, p_1), (q_2, p_2), \dots, (q_n, p_n)$ describe n closed curves.

$\iint dq_n dp_n$ is the area enclosed by the h^{th} projection curve.

Remarks: A. The numerical value of $\frac{2T}{\nu}$ does not change if in the description of the motion we pass from one system of coordinates $q_1 \dots q_n$ and the corresponding $p_1 \dots p_n$ to another one $q'_1 \dots q'_n$ and the corresponding $p'_1 \dots p'_n$. Therefore the right hand side of (7) can neither change its numerical value.

B. There are systems, for which if the system of coordinates has been chosen rightly, not only the total sum on the right hand side of (7) is an adiabatic invariant, but also the single terms $\iint dq_n dp_n$ (comp. the example in § 7). In this case we obtain thus at once more invariants.

C. For a system of one degree of liberty :

$$\frac{2T}{\nu} = \iint dq dp \text{ is an adiabatic invariant (8)}$$

according to (7) viz.: for a system of one degree of liberty the area enclosed by the phase curve in the (q, p) plane is an invariant (in this case there are no other invariants independent of this one).

D. A theorem of P. HERTZ (1910)²⁾. Give definite values $\alpha_1, \dots, \alpha_n$ to the parameters and consider some motion compatible with these. The corresponding path of phase in the (q, p) space lies on a definite hypersurface of constant energy $\varepsilon(q, p, \alpha_0) = \varepsilon_0$. This hypersurface encloses a definite $2n$ dimensional volume :

$$\int \dots \int dq_1 \dots dp_n = V_0. \dots \dots (9)$$

In the first place an adiabatically reversible influencing $\alpha_0 \rightarrow a$ works on the system. Secondly the hypersurfaces have now another position in the (q, p) space than before. We may now consider the volume V of that energy surface on which the phase path of the system lies *after* the adiabatic influencing. The theorem of P. HERTZ teaches now :

¹⁾ This expression needs further interpretation, if e. g. one of the coordinates is an angle and this angle increases each period with 2π .

²⁾ P. HERTZ: Mechanische Grundlag. d. Thermod. Ann. d. Ph. **33** (1910) p. 225—274 ; p. 537—552. [§ 11. Adiab. Vorgänge. Comp. 173]. P. HERTZ in "Repert. d. Physik" (TEUBNER 1916) p. 535 Comp. (7).

$$V = V_0 \dots \dots \dots (10)$$

For a system with *one* degree of liberty (10) and (8) are evidently identical; for a system with more degrees of liberty this is however not the case ¹⁾.

§ 6: *Connection between the adiabatic hypothesis and the quantum-hypotheses of PLANCK, DEBIJE, and others for systems with one degree of liberty.* PLANCK's hypothesis of the energy steps (1901) says, that a harmonically vibrating resonator of the frequency ν_0 can only have one of the following energies ε : ²⁾

$$\varepsilon = 0, h\nu_0, 2h\nu_0, \dots \dots \dots (11)$$

Therefore the adiabatic invariant of the resonator can only have the values

$$\frac{\varepsilon}{\nu_0} = \frac{\overline{2T}}{\nu_0} = \iint dqdp = 0, h, 2h, \dots \dots \dots (12)$$

Let us now consider a resonator with the non-linear equation of motion

$$\ddot{q} = -(\nu_0^2 q + a_1 q^2 + a_2 q^3 + \dots) \dots \dots (13)$$

This does not execute harmonic vibrations; the frequency $\nu \neq \nu_0$ of its oscillations depends not only on a_1, a_2, \dots but also on the intensity with which they are excited.

For the special parameter values $a_1 = a_2 \dots = 0$ it becomes the resonator of PLANCK. Therefore the adiabatic hypothesis (comp. the formulation in § 3) becomes: For these non-harmonic resonators too only those motions are possible for which

$$\frac{\overline{2T}}{\nu} = \iint dqdp = 0, h, 2h, \dots \dots \dots (14)$$

From the hypothesis of PLANCK's energy-steps we have thus

¹⁾ In the deduction of his theorem P. HERTZ has to calculate the mean with respect to the time of the force acting on the parameter a . He replaces this mean with respect to the time by a corresponding numerical mean in a microcanonical ensemble. It is known that BOLTZMANN and MAXWELL have only been able to justify this way of proceeding by the assumption that the considered system is ergodic.

A resonator with *one* degree of liberty is really ergodic. This is however not the case for molecules with two or more degrees of liberty. Therefore a special investigation is needed here whether the above defined quantity V_0 is adiabatically invariant. If for all degrees of liberty of a molecule only harmonic vibrations can occur, V_0 is really an adiabatic invariant:

$$V_0 = \frac{\varepsilon_1}{\nu_1} \cdot \frac{\varepsilon_2}{\nu_2} \cdot \frac{\varepsilon_3}{\nu_3} \dots \dots$$

²⁾ Comp. the note in § 2.

deduced by means of the adiabatic hypothesis the quantum hypothesis DEBYE gives for the values of $\iint dq dp$ for non-harmonic vibrations.¹⁾

Let us suppose that an electric dipole with the electric moment a_1 and the moment of inertia a_2 can rotate about the Z -axis.²⁾ An orientating field of the intensity a_3 may act parallel to the x -axis. As coordinate may be chosen the angle over which the dipole has turned.

If we begin with very great values of a_1 , a_3 and also of a_2 , then we may regard the vibrations as *infinitesimal* also for considerable values of the energy with which they are excited: a resonator of PLANCK. By letting a_2 and a_3 decrease infinitely slowly we can pass reversibly adiabatically to vibrations of finite amplitude, finally reversing the pendulum. If then the moment of inertia is kept constant, while the orientating field decreases to zero, we finally obtain *molecules on which no force is acting and which therefore are rotating uniformly*. For all these adiabatically related motions the adiabatic invariant

$$\frac{2T}{\nu} = \iint dq dp$$

is thus necessarily confined to the original values $0, h, 2h, \dots$. If for the uniform rotation with frequency ν this is identified with the number of complete rotations of the dipole per second:

$$\nu = \pm \frac{\dot{q}}{2\pi} \dots \dots \dots (15)$$

while it is taken into consideration that

$$2T = 2T = p\dot{q} \dots \dots \dots (16)$$

it is therefore required that p can have no other values than

$$p = 0, \pm \frac{h}{2\pi}, \pm 2\frac{h}{2\pi}, \dots \dots \dots (17)$$

Remark: The considerations given above must still be completed, especially with a view to the difficulty, that during the adiabatic change the singular, *non-periodic* motion is passed, which forms the

1) P. DEBJF. Zustandsgleich. u. Quantenhyp. ("Wolfskehlwoche" TEUBNER 1914) § 3.

S. BOGUSLAWSKY. Pyroelektricität auf Grund der Quantentheorie. Phys. Zschr. 15 (1914) p 569 gl. 3

2) Comp. the treatment and application of this example in communication B § 2 and C § 3, and especially see the figure in C § 3.

limit between the pendulum motions and the rotations. It must therefore be investigated, how the invariants of both kinds of motion are connected. ¹⁾

§ 7. *Connexion with SOMMERFELD'S quantum hypothesis for systems with more than one degree of liberty.*

We want to show, that the adiabatic law is satisfied by the quantum hypothesis recently given by SOMMERFELD for the plane motion of a point about a centre of attraction according to NEWTON'S law.

Let $\chi(r, a_1, a_2, \dots)$ be the potential of a central attracting force. Then the differential equations of the plane motion of a point are in polar coordinates: $r = q_1, \varphi = q_2$

$$mr - mr\dot{\varphi}^2 + \frac{d\chi}{dr} = 0 \dots \dots \dots (18a)$$

$$\frac{d}{dt}(mr^2\dot{\varphi}) = 0 \dots \dots \dots (18b)$$

(18b) expresses directly — which is very plausible — that the moment is invariant with respect to a change of the parameters a_1, a_2, \dots

$$mr^2\dot{\varphi} = p_2 \text{ adiabatically invariant } \dots \dots (19)$$

By eliminating $\dot{\varphi}$ by means of (19) from (18a) we obtain

$$mr = \frac{mr^3}{p_2^2} - \frac{d\chi}{dr} \dots \dots \dots (20)$$

This differential equation has the same structure as if it described the motion of a point oscillating under the influence of a force with the potential:

$$\Phi = -\frac{p_2^2}{2mr^2} + \chi(r, a_1, a_2) \dots \dots \dots (21)$$

over a fixed straight line between two extreme values of r ($r_A > r_B > 0$). For this periodic motion (of one degree of liberty) however we have according to §§ 4 and 5 the adiabatic invariant:

$$\frac{\overline{2T_1}}{v_1} = \iint dq_1 dp_1 = \text{adiabatically invariant } \dots \dots (22)$$

Equation (19) may be formulated in an analogous way:

$$\frac{\overline{2T_2}}{v_2} = \iint dq_2 dp_2 = \text{adiabatically invariant } \dots \dots (23)$$

¹⁾ Perhaps this will be possible by considering the *conical* pendulum or a system acted upon by a magnetic force. As to this uncertainty comp. § 9 of this communication and § 3 of communication C.

As

$$\frac{\overline{2T_2}}{v_2} = \frac{p_2 \dot{q}_2}{\left(\frac{q_2}{2\pi}\right)} = 2\pi p_2 = \int_0^{2\pi} dq_2 \cdot p_2 = \iint dq_2 dp_2$$

SOMMERFELD introduces the quanta by the equations:

$$\iint dq_1 dp_1 = 0, h, \dots, nh, \dots \quad (24)$$

$$\iint dq_2 dp_2 = 0, h, \dots, n'h, \dots \quad (25)$$

These hypotheses are thus actually in harmony with the adiabatic hypothesis (comp. the formulation in § 3).

Remarks. A: We see that the adiabatic invariants (22) and (23) do not only exist for the periodic motions about a centre of force which attracts either according to the law of NEWTON-COULOMB or elastically ($\chi = \frac{a}{r}$ or $\chi = \frac{ar^2}{2}$), but also for the quasi-periodic motion (in a rosette) about a centre of force with general $\chi(r, a)$. But in the first case are $v_1 = v_2 = v$, so that the invariants can be taken together to:

$$\frac{2(\overline{T_1 + T_2})}{v} = \frac{2\overline{T}}{v} = \text{adiabatically invariant}$$

(comp. here remark *B* of the appendix).

B. Now it would be interesting to find the adiabatic invariants for more general quasi-periodic motions, (in the first place for anisotropic instead of isotropic fields of force). This would at the same time furnish an answer to the question to which system of coordinates SOMMERFELD'S quantum hypotheses have to be applied¹⁾.

C. If the attracting force obeys COULOMB'S law, the hypothesis (23) is equivalent with PLANCK'S²⁾ new method of introducing the quanta, as has been remarked by SOMMERFELD (p. 455). This is also the case, when we have to do with an elastic attraction³⁾.

I have not yet succeeded in finding a more general connexion between the adiabatic hypothesis and PLANCK'S new assumptions.

D. In the refinement of his theory SOMMERFELD has still taken into consideration the dependency of the mass of the electron on

¹⁾ A. SOMMERFELD. Zur Theorie d. Balmer'schen Serie. Sitzber. Bayr. Ak. 1916 p. 425—500; See p 455 at the bottom.

²⁾ M. PLANCK. We again leave aside, that PLANCK only speaks of "critical" motions, beside which also the other motions are "stable".

³⁾ Comp. Appendix II.

its velocity. This causes the motion to take place no longer in a closed curve, the path becoming a rosette and an uncertainty arising as to the limits between which the integrals in (23) have to be taken ¹⁾. In order that we might make a conclusion from the viewpoint of the adiabatic hypothesis, it would first have to be investigated, which quantities are adiabatically invariant in this case.

§ 8. *Connexion of the adiabatic hypothesis with the statistic basis of the second law* ²⁾.

BOLTZMANN'S statistical mechanical deduction of the second law and especially of the equation

$$\frac{E + A_1 \Delta a_1 + A_2 \Delta a_2 + \dots}{\Theta} = k \Delta \log W \quad (26)$$

has been based upon a definite agreement as to what regions in the (q, p) space for the molecules ("μ-space") will have to be considered as "a priori equally probable". As such regions were taken to which in the μ-space equal volumina $\int . . . \int dq_1 . . . dp_n$ viz. correspond. BOLTZMANN ascribes the same weight to each part of the μ-space

$$G(q, p) = \text{constant}$$

By the hypothesis of PLANCK'S energy-steps and its generalizations this no longer holds, for here a weight

$$G(q, p, a)$$

dependent on q , p , and a we may say to be introduced. In other words to all regions of the μ-space the weight zero is ascribed, except to the discontinuously spread "admissible" regions, the situation of which is defined by the value of the parameters a . Here especially this last circumstance is of importance.

The problem may be formulated in the following way: How must we confine the choice of the weight function $G(q, p, a)$ —how that of the "admissible" regions especially with regard to their dependency on the a 's—in order that BOLTZMANN'S equation (26) remains valid?

This question has been treated by the author, first in a special case ³⁾, afterwards generally ⁴⁾.

¹⁾ A. SOMMERFELD l. c. p. 499

²⁾ Comp P. EHRENFEST. Zum BOLTZMANN'Schen Entropie-Wahrsch. Theorem. Phys. Zschr. 15 1914 p. 657.

³⁾ Comm. A (1911) § 5.

⁴⁾ Comm. D (1914).

in a vessel with rough walls impacts between the molecules occur or not ¹⁾.

Generalizing the question might be put as follows: Is in an ensemble of molecules one *most probable* state converted into an other *most probable* one, if the molecules are subjected to a reversible adiabatic change also when no mutual action exists between the molecules? In general this question must be *denied*. This is evident for the case that can be treated completely viz for that of molecules with *one* degree of liberty. The above mentioned supposition is only true, (but then always) when between the invariant for adiabatic processes and ε and ν there exists a relation of the special form

$$\varepsilon = A(a) \frac{\overline{2T}}{\nu} + B(a) \dots \dots \dots (32)$$

§ 9. *Difficulties which occur, if the adiabatic reversible change gives rise to a singular motion. Non-periodic motions.*

These difficulties are already met with at the adiabatic change of an oscillation into a uniform rotation (remark § 6). In somewhat different form they occur, when the vibrations in an *anisotropic* field of force are changed in an adiabatic reversible way into those of an *isotropic* field ²⁾. Let the mass of the moving point be *one*, the potential energy of the field of force

$$\Phi = \frac{1}{2}(\nu_1^2 \xi_1^2 + \nu_2^2 \xi_2^2)$$

For the case of isotropy

$$\nu_1 = \nu_2 = \nu \dots \dots \dots (33)$$

SOMMERFELD's way of introducing the quanta may be characterized as follows ³⁾:

Only those motions are admissible, for which the moment of momentum $m\nu^2 \dot{\varphi}$ and the total energy satisfy the equations:

$$2\pi m\nu^2 \dot{\varphi} = n\hbar \dots \dots \dots (33a)$$

$$\frac{\varepsilon}{\nu} = (n+n')\hbar \dots \dots \dots (34)$$

(n and n' are arbitrary whole numbers).

¹⁾ The two mentioned cases have this in common, that the pressure depends only on the total energy of the system and not on the distribution over the different principal vibrations (molecules).

²⁾ Already in 1912 in a paper "On energy elements" (Versl. Kon. Akad. 1912, Dl. XX p. 1103), H. A. LORENTZ drew the attention to the fact that in the quantum theory difficulties arise for isotropic resonators with two or three degrees of liberty.

³⁾ Comp Appendix. II.

In the case of *anisotropy* on the other hand PLANCK'S hypothesis of the energy steps is usually applied to each of the principal vibrations separately:

Only those motions are steady for which the energy belonging to the two principal vibrations (ε_1 and ε_2) satisfies the equations:

$$\frac{\varepsilon_1}{r_1} = n_1 h \quad , \quad \frac{\varepsilon_2}{r_2} = n_2 h \quad . \quad . \quad . \quad . \quad . \quad (35)$$

Let v_1 and v_2 approach infinitely slowly to the common value v , then the quotients (35), being adiabatic invariants, remain constant and the total energy ε of the system satisfies finally the equation:

$$\frac{\varepsilon}{v} = (n_1 + n_2) h \quad . \quad . \quad . \quad . \quad . \quad . \quad (36)$$

which is in good agreement with (34).¹⁾

On the other hand it is not evident, why in this way only one of the discrete values (33) for the moment of momentum would be obtained.

When v_2 and v_1 have already become nearly equal to each other the motion takes place in a figure of LISSAJOUS, which "densely" covers a rectangle, (with sides parallel to the axes ξ_1 and ξ_2 , proportional to $\sqrt{\varepsilon_2}$ and $\sqrt{\varepsilon_1}$).

During this motion the moment of momentum does not remain constant, but oscillates slowly to and fro between zero (at the moments when the motion takes place nearly exactly along the diagonals of the rectangle) and certain maximal positive and negative limits²⁾ (at those moments in which the motion takes place on the largest ellipse described in the rectangle).

The more v_1 and v_2 approach to each other, the slower these oscillations of the moment of momentum are. Which value of the moment of momentum is reached after an infinitely slow adiabatic change in the case of *isotropy* depends therefore on a double boundary passage.

It is thus evident, that the adiabatic hypothesis needs a special completion to render the result in this case (and in analogous cases of the passage of singular motions) quite definite. It is to be hoped that a plausible completion will be found, which leads us to SOMMERFELD'S values (33) of the moment of momentum.

As we can pass adiabatically from the elastic central force to each arbitrary central force (comp. § 7), the quanta might be

¹⁾ [Remark at the correction]. P. EPSTEIN drew my attention to the fact, that there is no good agreement between (36) and (34), for the circular motion n' must be equal to 0, n arbitrary; in (36) however $n_1 = n_2$, therefore $n_1 + n_2$ even.

²⁾ $\pm 2 \sqrt{n_1 n_2} h$.

introduced for arbitrary central forces, starting from the hypothesis of the energy steps for harmonic vibrations.

Here we must also mention the difficulties which we meet when we want to apply the notion: reversible adiabatic change, adiabatic invariant etc. to an ensemble of non-periodic motions, as e.g. the *hyperbolic* motions of a point under the influence of a force of NEWTON or COULOMB: here too the change of the energy and the moment of momentum depend on a double boundary passage on the course of the complete motion from $t = -\infty$ to $t = +\infty$ and on the infinitely slow adiabatic change.

§ 10. *Conclusion.* The purpose of this paper was to show, that the adiabatic hypothesis and the notion of the adiabatic invariants are important for the generalization of the quantum theory to an always increasing number of classes of motion (§§ 6, 7); further they throw some new light on the question, for which conditions BOLTZMANN'S relation between entropy and probability remains valid (§ 8). The analyzation of the difficulties occurring at the passage of singular motions will perhaps lead to a completion of the adiabatic hypothesis. But at any rate I believe that in view of WIEN'S law it must be given in the quantum theory a special place to the reversible adiabatic processes.

APPENDIX I.

Proof, that $\frac{2T}{v}$ is an adiabatic invariant for a system

with periodic motions.

Let

$$L = T(q, \dot{q}, a) - \Phi(q, a)$$

be the function of LAGRANGE of the system (the motions of which are for the moment not yet supposed to be periodic). And let us consider two infinitely near systems, for which the parameters have the values: a_1, a_2, \dots and $a_1 + \Delta a_1, a_2 + \Delta a_2, \dots$ ¹⁾, further the moments t_A, t_B and $t_A + \Delta t_A, t_B + \Delta t_B$. We shall consider:

I a continuous passage of the system from the configuration q_{1A}, \dots, q_{nA} at the time t_A to the configuration q_{1B}, \dots, q_{nB} at the time t_B with the values of the parameters a (change I).

II a continuous passage of the system from the configuration $q_{1A} + \Delta q_{1A}, \dots$ at the time $t_A + \Delta t_A$ into the configuration $q_{1B} +$

¹⁾ For the sake of implicitly we shall further use only one parameter. It is easily seen that at each point of the discussion we can return to the case of more parameters.

+ $\Delta q_{1B} \dots$ at the time $t_B + \Delta t_A$ with the values of the parameters $\alpha + \Delta\alpha$ (change II).

For both changes we take the integral $\int_A^B dt \dot{L}$ and calculate the difference between the two values. By taking apart what remains at the beginning and at the end of the integration period we first obtain

$$\Delta \int_{t_A}^{t_B} dt L = L_B \Delta t_B - L_A \Delta t_A + \int_{t_A}^{t_B} dt \delta L \dots (a)$$

where δL is the difference between the values of L for two simultaneous phases of the motions viz.

$$\delta L = \sum_1^n \frac{\partial L}{\partial q_h} \delta q_h + \sum_1^n \frac{\partial L}{\partial \dot{q}_h} \delta \dot{q}_h + \frac{\partial L}{\partial \alpha} \Delta \alpha \dots (b)$$

where $\delta q_h, \delta \dot{q}_h$ are again differences for simultaneous phases. Therefore

$$\delta \dot{q} = \frac{d}{dt} (\delta q) \dots (c)$$

By partial integration of the integral in (a) we obtain therefore:

$$\begin{aligned} \Delta \int_{t_A}^{t_B} dt L &= (L_B \Delta t_B - L_A \Delta t_A) + \\ &+ \sum_1^n \left(\frac{\partial L}{\partial \dot{q}_h} \right)_B \delta q_{Bh} - \sum_1^n \left(\frac{\partial L}{\partial \dot{q}_h} \right)_A \delta q_{hA} + \\ &+ \int_{t_A}^{t_B} dt \sum_1^n \delta q_h \left\{ \frac{\partial L}{\partial q_h} - \frac{d}{dt} \left(\frac{\partial L}{\partial \dot{q}_h} \right) \right\} + \\ &+ \Delta \alpha \int_{t_A}^{t_B} dt \frac{\partial L}{\partial \alpha} \dots (d) \end{aligned}$$

As however δ refers to simultaneous, Δ to non-simultaneous phases we have:

$$\left. \begin{aligned} \delta q_{hA} &= \Delta q_{hA} - \dot{q}_{hA} \Delta t_A \\ \delta q_{hB} &= \Delta q_{hB} - \dot{q}_{hB} \Delta t_B \end{aligned} \right\} \dots (e)$$

Further:

$$\frac{\partial L}{\partial \dot{q}_h} = \frac{\partial T}{\partial \dot{q}_h} = p_h \dots (f)$$

So that we obtain:

$$\begin{aligned} \Delta \int_{t_A}^{t_B} dt L = & \left(\Delta t \left\{ L - \sum_1^n p_h \dot{q}_h \right\} \right)_A^B + \\ & + \left(\sum_1^n p_h \Delta q_h \right)_A^B + \\ & + \int_{t_A}^{t_B} dt \sum_1^n \delta q_h \left\{ \frac{\partial L}{\partial q_h} - \frac{d}{dt} \left(\frac{\partial L}{\partial \dot{q}_h} \right) \right\} + \\ & + \Delta a \int_{t_A}^{t_B} dt \frac{\partial L}{\partial a} \dots \dots \dots (g) \end{aligned}$$

Supposition A. The change I is a mechanical motion belonging to the values of the parameters (α). Therefore:

$$\frac{\partial L}{\partial q_h} - \frac{d}{dt} \left(\frac{\partial L}{\partial \dot{q}_h} \right) = 0. \dots \dots \dots (h)$$

so that

$$+ \frac{\partial L}{\partial a} = A \dots \dots \dots (i)$$

where ($-A$) is the external force, which at every moment must act on the system according to the parameter α , in order that α remains constant. Then also the total energy of the system

$$L - \sum p_h \dot{q}_h = T - \Phi - 2T = -E. \dots \dots \dots (j)$$

remains constant during the motion (α is kept constant, so that during the motion no work is done on the system!) We thus obtain

$$\left. \begin{aligned} \Delta \int_A^B dt (T - \Phi) = & -E \cdot \Delta(t_B - t_A) + (t_B - t_A) \bar{A} \Delta a \\ & + \sum_1^n p_{hB} \Delta q_{hB} - \sum_1^n p_{hA} \Delta q_{hA}, \end{aligned} \right\} (k)$$

where \bar{A} is the mean with respect to the time of the force A for the interval t_A, t_B .

Supposition B. The change II is also a mechanical motion and belongs to the parameter values $\alpha + \Delta\alpha$. Then $T + \Phi = E$ has also for this second motion a value $E + \Delta E$, which does not change with the time. Therefore

$$\Delta \int_A^B dt (T + \Phi) = \Delta \{E(t_B - t_A)\} = (t_B - t_A) \Delta E + E \Delta(t_B - t_A) \quad (l)$$

Adding (l) to (k) we obtain

$$\Delta \int_{t_A}^{t_B} dt \cdot 2T = (t_B - t_A) [\Delta E + \overline{A} \Delta a] + \Sigma p_{hB} \Delta q_{hB} - \Sigma p_{hA} \Delta q_{hA} \quad (m)$$

Supposition C. Let both motions be periodic (periods P and $P + \Delta P$). Let us now take for both motions the time integral over their period. Now

$$p_{hB} = p_{hA}, \text{ further } q_{hB} = q_{hA}$$

and

$$q_{hB} + \Delta q_{hP} = q_{hA} + \Delta q_{hA}$$

so that the two last terms of the right hand side of (m) neutralize each other. We thus find:

$$\Delta \int_{t_A}^{t_B} dt \cdot 2T = P [\Delta E + \overline{A} \Delta a], \quad \dots \quad (n)$$

Supposition D. The motions I and II can be adiabatically changed into each other. The adiabatic change {I, II} lasts a time rather long compared with P and $P + \Delta P$. Only during this time the parameter a changes (from a to $a + \Delta a$). At the same time the system does the work

$$\overline{A} \Delta a$$

on the outer force. This is just the difference between the energies of the motions II and I, the latter being the larger of the two.

$$\Delta E = - \overline{A} \Delta a \quad \dots \quad (p)$$

Therefore

$$\Delta' \int_0^P dt \cdot 2T = 0 \quad \dots \quad (q)$$

The symbol Δ' will remind us, that we have not to do with an arbitrary variation, but that just two adiabatically related motions are compared. This is the proof of equation (3) in § 5.

Remarks: A: Equation (n) has been deduced already by BOLTZMANN and CLAUSIUS, when they tried to deduce the entropy law purely mechanically without using statistical methods¹⁾.

They do not confine themselves to adiabatic influences and consider therefore the quantity:

$$\Delta E + \overline{A} \Delta a = \Delta Q \quad \dots \quad (r)$$

¹⁾ L. BOLTZMANN. Wien. Ak. 53 (1866) p. 195 [= Abh. Bd. I N^o. 2]; Pogg. Ann. 143 (1871) p. 211 [= Abh. I N^o. 17]; Vorles. Princ. d. Mech. Bd. II. p. 181. R. CLAUSIUS Pogg. Ann. 142 (1870) p. 433.

as the added heat. Then equation (n) becomes:

$$P\Delta Q = 2\Delta(\overline{PT}) \dots \dots \dots (s)$$

or

$$\frac{\Delta Q}{T} = \Delta \log(\overline{PT})^2 \dots \dots \dots (t)$$

This equation is then compared with the entropy law.

B. BOLTZMANN has further investigated, whether it is possible to alter the above considerations, referring to systems with periodic motions, in such a way that they may be applied to systems with quasi-periodic motions e.g. to the motion of a point in a rosette under the influence of a centre of force¹⁾.

Now the terms $\sum p_h \Delta q_h$ in equation (n) give rise to difficulties. These terms do not vanish now, neither by an integration from one perihelium to another, nor for one on a complete rotation ($\varphi = 0$ to $\varphi = 2\pi$). Therefore BOLTZMANN has still tried the following: On both paths he chooses such stretches that these terms vanish and speaks then of "orthogonal" variations of the end configurations A and B. If however we pass from a motion I through different intermediate motions to a finitely different motion (N), going back again to (I) through other intermediate motions, then the succeeding "orthogonal" variations finally give other end configurations A and B for the motion than those from which we started (BOLTZMANN has illustrated this with examples).

From this BOLTZMANN concluded that the second law would have to be derived not by means of pure mechanics, but only by statistic mechanics. Proceeding as in § 7 it is however possible to indicate adiabatic invariants also for such a case.

APPENDIX II.

Motions in an isotropic elastic field of force according to the quantum hypothesis of SOMMERFELD. Comparison with PLANCK's formulæ.

Let us put:

$$\left. \begin{aligned} \varphi &= q, & r &= q' \\ m r^2 \dot{\varphi} &= p, & m \dot{r} &= p' \end{aligned} \right\} \dots \dots \dots (a)$$

Then according to SOMMERFELD:

$$\iint dq dp = nh \dots \dots \dots (b) \quad , \quad \iint dq' dp' = n'h \dots \dots \dots (c)$$

Now we have however:

¹⁾ L. BOLTZMANN. Bemerk. über einige Probleme der mechan. Wärmetheorie Cap. III. (Wien. Ak. 75 (1877) p. 62--100 = Abh. II. p. 122); Vorles. über Princ. d. Mech. Bd II. p. 156.

$$\left. \begin{aligned} n'h &= \iint dq' dp' = \int dq' \cdot p' = \int dr \cdot m\dot{r} = \int_0^P dt \cdot m\dot{r}^2 \\ \int_0^P dt (2T - m\dot{r}^2) &= \frac{2\bar{T}}{\nu} - 2\pi p = \frac{\varepsilon}{\nu} - 2\pi\bar{p} \end{aligned} \right\} \quad (d)$$

where ν is the frequency, T the total kinetic energy, ε the total energy of the system ($2\bar{T} = \varepsilon$, the oscillations being harmonic).

On the other hand, (b) gives:

$$nh = \int dq \cdot p = 2\pi p \quad \dots \dots \dots (e)$$

substituting this on the right hand side in (d) we obtain:

$$\frac{\varepsilon}{\nu} = (n + n') h \quad \dots \dots \dots (f)$$

In this way the equations (33) and (34) of § 9 have been deduced.

In order to compare this result with the formulae recently given by PLANCK, we remark that each of these motions takes place in an ellipse, so that (with respect to its principal axes) it may be represented by the equations

$$x = a \cos \omega t \quad , \quad y = b \sin \omega t \quad \dots \dots \dots (g)$$

(a and b being the semi-axes of the ellipse, $\omega = 2\pi\nu$)

$$p = m(\dot{x}y - y\dot{x}) = \omega mab \quad \dots \dots \dots (h)$$

$$\frac{\varepsilon}{\nu} = m\omega\pi (a^2 + b^2) \quad \dots \dots \dots (i)$$

Therefore according to (e) and (f):

$$ab = \frac{nh}{2\pi\omega m} \quad \dots \dots \dots (j)$$

$$a^2 + b^2 = \frac{(n + n')h}{\pi\omega m} \quad \dots \dots \dots (k)$$

or:

$$(a - b)^2 = \frac{nh}{\pi\omega m} \quad \dots \dots \dots (l)$$

Equation (j) is identical with the value given by PLANCK (see equation (65) of his paper). For $(a - b)^2$ however he gives values which are twice too high.

Postscript at the correction. Meanwhile EPSTEIN has published some highly interesting papers [Ann. d. Phys. **50** (1916) p. 489, p. 815], which show the importance of STÄCKEL's method of the

"separation of the variables" for the quantization of the motions of more degrees of liberty. Therefore the question may be put: In how far are the additional parts, with which P. EPSTEIN and also P. DEBIJE [Gött. Nachr. 1916] form the action integral adiabatic invariants? In SOMMERFELD'S case they are still invariant, as shown in § 7.

Physics. — "*On the electric resistance of thin films of metal*". By S. WEBER and E. OOSTERHUIS. (Communicated by H. KAMERLINGH ONNES).

(Communicated in the meeting of Sept. 30, 1916).

I. *Introduction.*

Various investigations have shown that the specific resistance of thin films of metal differs from the normal value, which is found for thicker layers of the metal. This fact is of importance in connection with the theory of electric conduction in metals.

The first investigations of the subject were made by A. C. LONGDEN¹⁾ and by J. PATTERSON²⁾; they obtained the following results which have been on the whole confirmed by later investigators:

1. The specific resistance of thin metallic films may become many times larger than the normal value; the specific resistance, when measured for films of diminishing thickness, is found to increase gradually; beyond a definite thickness (for platinum about $7 \mu\mu$) this increase becomes pretty suddenly much stronger.

2. The temperature-coefficient of the electric resistance is negative for very thin films; as for thick layers the temperature-coefficient has a positive value, there must be a definite thickness for which the metallic film has a temperature coefficient equal to zero.

3. The resistance of thin metallic films changes with time and ultimately reaches a constant value. This final value may be reached in a shorter time by heating the substance,

The question at what thickness a perceptible conduction begins to show itself in a metallic film was investigated by A. RIEDE³⁾ and B. POGÁNY⁴⁾ amongst others; for most metals the beginning of conduction was observed in films of from 1 to $3 \mu\mu$ thickness, only

¹⁾ A. C. LONGDEN. Phys. Rev. 11. p. 40. 1900.

²⁾ J. PATTERSON. Phil. Mag. Vol. 4. Ser. 6. p. 652. 1902.

³⁾ A. RIEDE. Ann. der Phys. Bd. 45. p. 881. 19'4.

⁴⁾ B. POGÁNY. Ann. der Phys. Bd. 49. p. 531. 1916 and Phys. Z.S. 17. p. 251. 1916.

silver forming an exception; in this case conduction did not become perceptible, until the films were several times thicker.¹⁾

J. J. THOMSON²⁾ discussed the conduction in thin metallic films from the point of view of the electron-theory; but his theory is not in good accordance with the observations. W. F. G. SWANN³⁾ tries to find an explanation by assuming, that the films are not built up out of molecules but of complexes⁴⁾ of molecules. He gives a mathematical discussion of the electric conduction between complexes of that nature, starting from special assumptions regarding the mobility of electrons. In this manner he succeeds in explaining the sudden rapid increase of the specific resistance, as also the negative temperature-coefficient of thin films. His theory leads to the conclusion that for very thin films OHM's law would no longer hold.

In all the above-mentioned investigations films were used which had been formed either by chemical methods or by means of cathode-discharge. Measurements on the electric resistance of metallic films formed by *evaporation* have not been made so far. Still films obtained by that process offer several advantages as compared to those formed in a different manner:

1. The film is easily obtained perfectly uniform⁵⁾.

2. According to the kinetic theory, it must be assumed, that a metal evaporates as molecules, not as complex groups of molecules; this assumption is moreover in accordance with KNUDSEN's⁶⁾ measurements on the maximum rapidity of evaporation of mercury.

KNUDSEN⁷⁾ has further shown, that a molecule which escapes from the evaporating metal at the first collision with the wall adheres to it, if the temperature of the wall is sufficiently lower than that of the evaporating metal; from which it may be inferred, that the thin metallic films which are formed by evaporation consist of molecules and not of molecular complexes⁸⁾.

3. The film is formed in a high vacuum, so that there can be no danger of any reaction, chemical or otherwise, with gases.

For these reasons we have carried out the research on the electric resistance of thin metallic films which is related in this paper with

1) Comp. also L. HOULLEVIGUE. Ann. chim. phys. S. 8. T. 21. p. 197. 190.

2) J. J. THOMSON. Cambridge Proc. (2) XI. p. 120. 1901.

3) W. F. G. SWANN. Phil. Mag. Vol. 28. Ser. 6. p. 467. 1914.

4) Comp. also L. HOULLEVIGUE. l.c.

5) This disposes of the objection raised by RIEDE (l.c.), that the large increase of specific resistance of thin films might be due to inequalities of the thickness.

6) M. KNUDSEN, Ann. der Phys. Bd. 47, p. 697. 1915.

7) M. KNUDSEN, Ann. der Phys. Bd. 50, p. 472. 1916.

8) Comp., however, the remark on page 606.

films formed by *evaporation*. We have found that these films have the additional advantage of the time-change of the resistance mentioned above being much smaller than with films formed by chemical deposition or cathode discharge, which circumstance is naturally very favourable to obtaining constant results.

II. *The experiments.*

The experiments were made with thin films of platinum, tungsten and silver. The platinum was HERÆUS'S chemically pure platinum ($\alpha_{0-100} = 0.003905$); that both the other metals were also very pure was shown for tungsten by the value of the temperature-coefficient of the electric resistance and for silver by chemical analysis.

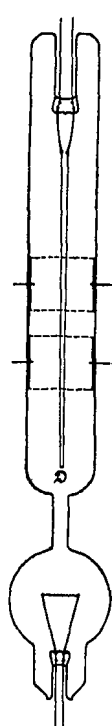

The formation of the films. The films were formed on the inner wall of a cylindrical glass tube (see fig. 1) about 36 mm. wide. Inside about half way up the tube two silvered rings R_1 and R_2 were produced on the wall of the glass, at a distance of about 16 mm. from each other. From each of the silvered rings two platinum wires sealed through the glass lead to the outside. By measuring the resistance between the two wires connected to the same ring it was possible to make sure, that a good contact was established between the platinum and the silver deposit. At the top of the glass cylinder two nickel wires are sealed into which is fused the wire D of the metal to be tested. The wire has the shape of a long hair-pin, with its two legs only a few millimetres apart. The diameter of the wire was taken such, that only small parts at the ends of the wire did not glow by the cooling effect of the wires which admit the current. The part of the wire which is opposite the rings and up to a few centimetres above the higher ring showed a perfectly uniform glow. To the lower end of the glass cylinder a lamp was sealed in which a tungsten spiral was enclosed. The whole was thoroughly evacuated, while at the same time the glass wall was heated and the wire D was made to glow, in order to free both from gases as completely as possible.

After the tube was sealed off from the pump, the tungsten spiral was kept at a very high incandescence for some time, by which process the last remnants of gas were removed and a very high vacuum was obtained. The wire D of the metal under examination was then made to glow at a constant temperature regulated so as

to make the evaporation take place at a suitable rate. By the evaporation the wire becomes continually thinner; in order to keep the temperature always the same, it is necessary that $\sqrt{V}i$ should remain constant¹⁾, where V represents the potential-difference between the ends of the wire and i the current in the wire.

By a suitable choice of the voltage (storage cells) and resistance it is possible to arrange, that this condition is satisfied without having to change the voltage or the resistance, at least as long as the thickness of the wire does not diminish by more than a few percents, as was the case in our experiments.

Determination of the thickness of the films.

The thickness of the films was calculated from the quantity of metal deposited per square centimetre of the glass wall, taking for the specific gravity the value which holds for the metal in thick layers. As the wire glows at a constant temperature, the vaporized quantity is proportional to the time and to the surface of the wire; as only a small fraction of the wire evaporates, the diminution of the surface of the wire was but small; the diminution was moreover taken into account. For tungsten the quantity which evaporates per second and per cm^2 of the wire surface is known as a function of the temperature²⁾. The constant temperature to which the tungsten was heated was calculated from current-strength and diameter of the wire; between the three quantities: current, diameter and temperature a certain relation holds which could be derived from the formula for the total radiation of tungsten as given by LANGMUIR³⁾ and from measurements made in this laboratory on the specific resistance of tungsten at high temperatures.

For platinum too the velocity of evaporation has been measured by LANGMUIR⁴⁾ as a function of the temperature, the temperature of the platinum wire was calculated from the total radiation using the formula given by LUMMER⁵⁾.

For the silver we determined the total quantity evaporated at the close of the experiments from the loss of weight of the wire; the total time being known during which the wire has been heated, the quantity vaporized per unit of time may be calculated.

As a check on the calculations the total loss of weight of the

¹⁾ Comp. I. LANGMUIR, Phys. Rev. Vol. II, p. 335, 1913.

²⁾ I. LANGMUIR, Phys. Rev. Vol. II, p. 329, 1913.

³⁾ I. LANGMUIR, Phys. Rev. Vol. XXXIV, p. 417, 1912.

⁴⁾ I. LANGMUIR, Phys. Rev. Vol. IV, p. 377, 1914.

⁵⁾ O. LUMMER: Verflüssigung der Kohle und Herstellung der Sonnentemperatur. p. 42. Vieweg 1914.

wire was measured at the end of the experiments for tungsten and platinum also; the result agreed to within 2% with the loss of weight as derived from the above calculations. As the wire D is made much longer than the distance between the silvered rings, the quantity of metal deposited between the two rings may with near approximation be assumed to be equal to the total quantity evaporated from a piece of the wire equal in length to the distance of the rings.

Measurement of the resistance of the films.

The wire was heated at constant temperature during a given time, the resistance of film formed was then measured (the thickness of which as shown above is to be calculated from the velocity of evaporation), the wire was then heated again for a given time, the resistance of the film which had now increased in thickness was measured, etc.

Proceeding in this manner possible changes of the resistance of the films with time are eliminated, seeing that the thickness of the film is made greater by evaporation, as soon as the resistance-measurement is finished, and that the change of the resistance in the course of an experiment was inappreciable.

For the thinnest films the resistance was determined by measuring the current which is transmitted at a known voltage, by means of a sensitive galvanometer. For films of smaller resistance WHEATSTONE'S bridge was used and for those of the smallest resistance, where it becomes necessary to eliminate the influence of the leading-in wires, KOHLRAUSCH'S method of the overlapping shunts was used.

In order to be able to deduce the specific resistance from the measured resistances, the distance between the silvered rings and the internal diameter of the glass cylinder was also measured.

Results.

The measurements were made at a temperature of about 22° C.

The first column of Table I contains the thickness d in μ of the film, the second the measured resistances v in Ohms and the third the specific resistance σ expressed in Ohms per cm^2 .

Figure 2 gives a graphical representation of a part of the results given in the table.

The value given in brackets of the specific resistance for a thickness = ∞ was not measured by us, but is the value which is generally given as the specific resistance of pure platinum.

TABLE I. Platinum.

d	w	σ
0,875 $\mu\mu$	∞	—
1,645	$2,16 \cdot 10^8$	$1,89 \cdot 10^2$
1,775	$1,04 \cdot 10^8$	$0,98 \cdot 10^2$
1,990	$3,02 \cdot 10^7$	$3,18 \cdot 10^1$
2,120	$1,48 \cdot 10^7$	$1,66 \cdot 10^1$
2,360	$5,35 \cdot 10^6$	6,70
2,560	$2,48 \cdot 10^6$	3,36
2,780	$1,120 \cdot 10^6$	1,65
3,270	$1,765 \cdot 10^5$	$3,06 \cdot 10^{-1}$
3,810	$1,390 \cdot 10^4$	$2,80 \cdot 10^{-2}$
4,070	$3,55 \cdot 10^3$	$7,65 \cdot 10^{-3}$
5,00	$4,72 \cdot 10^2$	$1,25 \cdot 10^{-3}$
5,85	$2,03 \cdot 10^2$	$6,30 \cdot 10^{-4}$
6,85	$1,09 \cdot 10^2$	$3,96 \cdot 10^{-4}$
7,10	$9,29 \cdot 10^1$	$3,50 \cdot 10^{-4}$
7,55	$7,21 \cdot 10^1$	$2,88 \cdot 10^{-4}$
8,20	$5,85 \cdot 10^1$	$2,54 \cdot 10^{-4}$
9,15	$4,26 \cdot 10^1$	$2,06 \cdot 10^{-4}$
10,45	$2,980 \cdot 10^1$	$1,65 \cdot 10^{-4}$
12,50	$1,885 \cdot 10^1$	$1,25 \cdot 10^{-4}$
14,25	$1,440 \cdot 10^1$	$1,09 \cdot 10^{-4}$
16,40	$1,090 \cdot 10^1$	$0,950 \cdot 10^{-4}$
22,20	6,52	$0,770 \cdot 10^{-4}$
25,85	5,20	$0,710 \cdot 10^{-4}$
32,70	4,00	$0,695 \cdot 10^{-4}$
64,40	2,005	$0,685 \cdot 10^{-4}$
76,60	1,675	$0,680 \cdot 10^{-4}$
84,50	1,520	$0,680 \cdot 10^{-4}$
126,0	1,020	$0,680 \cdot 10^{-4}$
[∞]	—	$0,10 \cdot 10^{-4}$]

The conduction of the film begins to be measurable at a thickness of $1.645 \mu\mu$; a black deposit is then already clearly visible on the glass wall; its absorption could be estimated by the eye by comparison

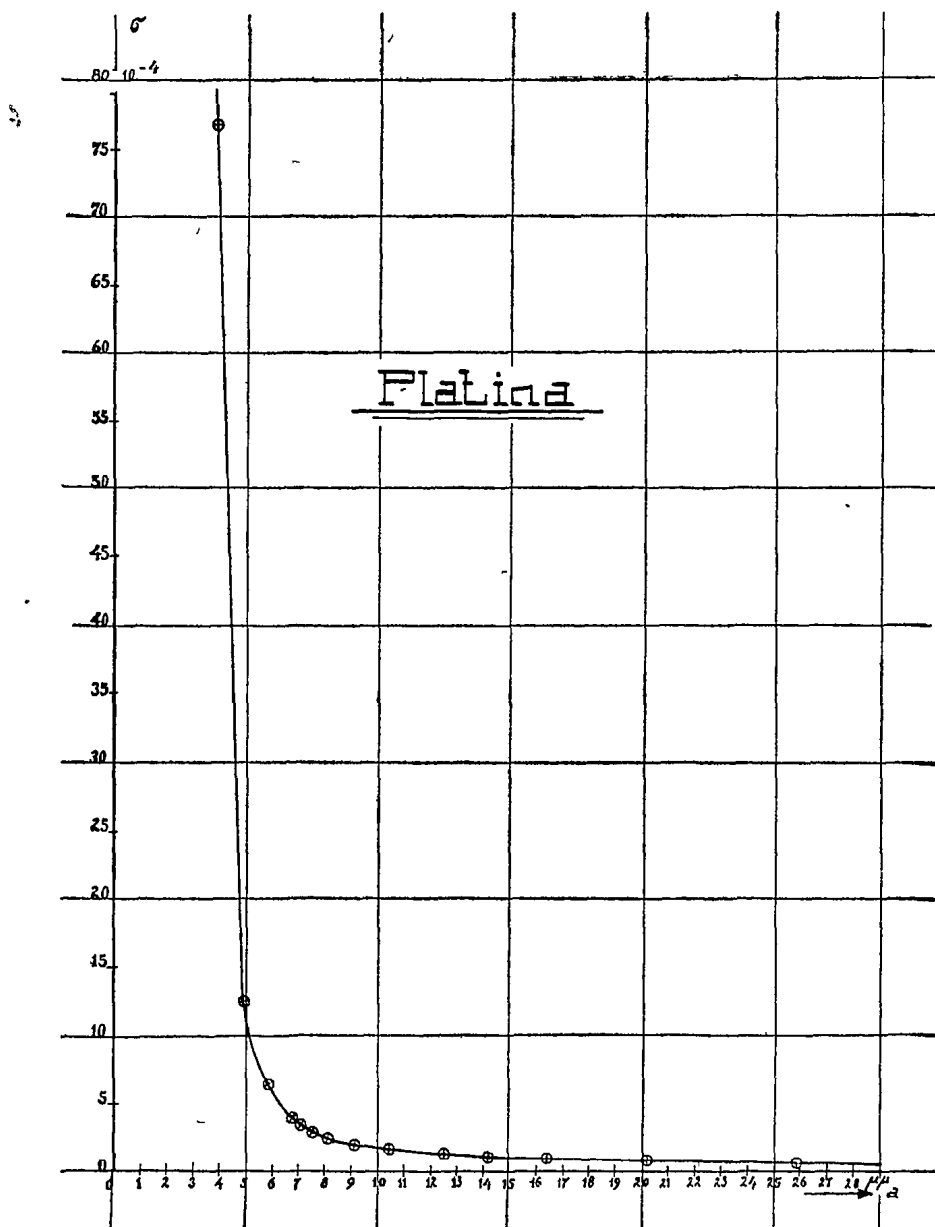

Fig 2.

to at least 10%. The rapid increase of the specific resistance begins with films of about 7μ . The results were confirmed by two series of measurements with other platinum wires which agreed with the data of Table 1 to within a few percentages.

TABLE II., Tungsten.

d	w	σ
0,420 $\mu\mu$	∞	—
0,458	$1,255 \cdot 10^7$	$266,0 \cdot 10^{-2}$
0,730	$0,755 \cdot 10^6$	$255,0 \cdot 10^{-3}$
1,215	$1,655 \cdot 10^4$	$935,0 \cdot 10^{-5}$
1,645	$4,500 \cdot 10^3$	$342,0 \cdot 10^{-5}$
1,885	$2,705 \cdot 10^3$	$236,0 \cdot 10^{-5}$
2,490	$1,340 \cdot 10^3$	$154,0 \cdot 10^{-5}$
3,335	$8,45 \cdot 10^2$	$130,5 \cdot 10^{-5}$
3,870	$6,95 \cdot 10^2$	$124,0 \cdot 10^{-5}$
8,30	$1,92 \cdot 10^2$	$73,8 \cdot 10^{-5}$
9,75	$1,215 \cdot 10^2$	$55,0 \cdot 10^{-5}$
11,15	$6,98 \cdot 10^1$	$36,0 \cdot 10^{-5}$
19,30	$1,79 \cdot 10^1$	$15,5 \cdot 10^{-5}$
$[\infty$	—	$0,5 \cdot 10^{-5}]$

With tungsten a perceptible conduction begins to appear at a thickness of about $0.5 \mu\mu$; the strong increase of the resistance begins at about $2.5 \mu\mu$. In this case two further measurements were made with wires which glowed at a different temperature; the results found were in good agreement with Table II.

In the measurements with the silver films a more sensitive galvanometer was used than in those with the platinum and tungsten films; had the same sensitiveness been used as with platinum, the conduction would have first appeared at a thickness of about $6.5 \mu\mu$. At this thickness of $6.5 \mu\mu$ the platinum film has a resistance of about 150 Ohm, that of tungsten one of about 300 Ohm and the silver film of 2×10^8 Ohm. The films formed by evaporation thus display the same deviation in the case of silver as was found by previous observers (comp. page 597). The strong increase of the specific resistance here occurs at a thickness of about $25 \mu\mu$.

A few series of measurements with other silver wires undertaken with a view to checking the results gave results agreeing in general features with those given in Table III, but there was no approach to the constancy of the results obtained with platinum and tungsten. We do not consider it altogether impossible, that the behaviour of

TABLE III. Silver.

d	w	σ
0,25 μ	∞	—
5,40	$7,60 \cdot 10^8$	$27,75 \cdot 10^2$
6,25	$4,10 \cdot 10^8$	$17,30 \cdot 10^2$
7,48	$5,88 \cdot 10^7$	$2,98 \cdot 10^2$
8,72	$0,970 \cdot 10^7$	57,2
9,70	$1,350 \cdot 10^6$	7,50
11,20	$0,720 \cdot 10^5$	$5,46 \cdot 10^{-1}$
11,55	$4,660 \cdot 10^4$	$3,62 \cdot 10^{-1}$
12,10	$3,420 \cdot 10^4$	$2,80 \cdot 10^{-1}$
12,75	$1,830 \cdot 10^4$	$15,75 \cdot 10^{-2}$
13,70	$9,070 \cdot 10^3$	$8,40 \cdot 10^{-2}$
14,57	$4,220 \cdot 10^3$	$4,16 \cdot 10^{-2}$
15,20	$2,335 \cdot 10^3$	$2,41 \cdot 10^{-2}$
16,30	$1,240 \cdot 10^3$	$1,355 \cdot 10^{-2}$
16,70	$0,935 \cdot 10^3$	$1,055 \cdot 10^{-2}$
18,20	$5,980 \cdot 10^2$	$7,380 \cdot 10^{-3}$
19,18	$3,980 \cdot 10^2$	$5,160 \cdot 10^{-3}$
21,45	$1,495 \cdot 10^2$	$2,180 \cdot 10^{-3}$
23,95	$5,35 \cdot 10^1$	$8,78 \cdot 10^{-4}$
29,70	6,20	$12,45 \cdot 10^{-5}$
32,65	2,20	$48,60 \cdot 10^{-6}$
34,40	1,50	$34,80 \cdot 10^{-6}$
34,65	1,40	$32,90 \cdot 10^{-6}$
35,00	1,30	$30,75 \cdot 10^{-6}$
37,00	0,90	$22,55 \cdot 10^{-6}$
42,45	0,40	$11,55 \cdot 10^{-6}$
43,25	0,325	$9,50 \cdot 10^{-6}$
[∞]	—	$1,50 \cdot 10^{-6}$]

silver is not in all respects in accordance with the account given on page 598 of the formation of metallic films by evaporation; it might be possible that silver is actually deposited on the wall as molecules, but that subsequently changes in the structure of the film occur, consisting in the molecules combining to complex groups, and that this would cause the behaviour of silver to be different in various ways.

At much thinner films than that for which the conduction of silver begins the glass wall showed a coloured deposit; the colour changed with increasing thickness in the order: yellowish brown, pink, violet, blue¹).

Simultaneously with the beginning of conduction the film began to show metallic reflection and the reflected light ceased to show any colours; the transmitted light continued a blue colour.

Discussion of the results.

In comparing the results obtained by us with POGÁNY's measurements (l.c.) on films of platinum and silver, formed by cathode-deposit a tolerable agreement is found to exist as regards the thickness at which the layers first begin to conduct. Assuming as we do — at least for platinum — that conduction in a film formed by vapour-deposit first begins, when a sufficient number of molecules have been deposited for a continuous layer to be formed on the wall, the agreement in question would show, that with cathode-deposition films consisting of molecules and not of complexes may also be formed.

If we assume the dimensions of metallic molecules to be of the same order of magnitude as the value given for gaseous molecules, that is about 5×10^{-8} cm., the results show, that for conduction a film is needed two or three molecules thick with platinum, one molecule with tungsten and twelve molecules with silver.

For the thicker films the specific resistance may be satisfactorily represented as a function of the thickness by a hyperbola, as already observed by POGÁNY (l.c.). This relation may be interpreted on the electronic theory in the following simple manner: we shall consider a thin film of the metal 1 cm.^2 large and of a thickness d and we shall assume, that the electrons are impeded in their freedom of movement by the walls of the film. Let N be the number of electrons per cm.^3 ; the mean free path of the electrons inside the bulk of the metal may be called λ and the mean velocity of the electrons Ω . The number of collisions per second with the metallic molecules

¹) Comp. L. HOULLEVIGUE Ann. chim. phys S. S. T. 20. p. 143. 1910 and L. HAMBURGER, Chemisch Weekblad. 1916. p. 551.

will then be $\frac{dN\Omega}{\lambda}$ and that of collisions with the walls $2 \times \frac{1}{4}N\Omega$.

As the walls consist partly of molecules and partly of free spaces where forces may act on them, we will put the number of collisions with the walls equal to $f \times 2 \times \frac{1}{4}N\Omega$. The total number of collisions per second and per electron is thus $= \Omega \left(\frac{1}{\lambda} + \frac{f}{2d} \right)$.

Hence the mean free path of the electron in the film will be $= \frac{\lambda}{1 + \frac{f\lambda}{2d}}$.

Substituting this value in the formula given by the electronic theory we find the electric conductivity of the film equal to

$$\kappa = \frac{Ne^2 \Omega \lambda}{4\alpha T \left(1 + \frac{f\lambda}{2d} \right)}$$

whereas for the metal in thick layers the expression

$$\kappa_m = \frac{Ne^2 \Omega \lambda}{4\alpha T}$$

holds. Hence

$$\kappa = \kappa_m \frac{1}{1 + \frac{f\lambda}{2d}}$$

$$\frac{1}{\sigma} = \frac{1}{\sigma_m} \frac{1}{1 + \frac{f\lambda}{2d}}$$

$$(\sigma - \sigma_m) d = \frac{f}{2} \lambda \sigma_m = \text{constant}$$

which actually corresponds to a hyperbola. This simple reasoning naturally only holds, as long as λ is not too large with respect to d .

Finally some remarks may be made on the change of the resistance of thin metallic films with the time. As mentioned above, the change of the resistance of the films was negligible in our experiments; this is true for the temperature at which our experiments were made (room-temperature, about 22° C.). The matter becomes different, if the films are heated; we have investigated the behaviour of the films in heating more especially for platinum.

For comparatively thick films the change of the resistance on heating is not very great and after some time the resistance re-assumes a constant value; it was thus possible for films of about

126 μ to obtain definite results for the temperature-coefficient of the resistance; for two different specimens within the temperature range from 22° to 140° C. values of 0.00276 and 0.00244 respectively were found; as mentioned above the platinum wire from which the films were formed by evaporation has a temperature-coefficient of 0.003905.

Very thin films on the other hand behaved in an entirely different manner; as long as they remained at room-temperature, only a very small change of the resistance with the time was observed and even with the thinnest films no deviation from OHM's law could be established¹⁾ (the applied voltage varied from 0.1 of a volt to 60 volts). When these very thin films were heated, however, (to 130°), the resistance was found to increase rapidly and ultimately became infinite; the black appearance of the film does not thereby undergo any change. If the heating is stopped before the resistance has become infinite, the resistance after cooling has become much higher than before the heating, and moreover for a film in that condition OHM's law was found to be no longer valid; with an applied voltage of 1 Volt a resistance is found which is 2.4 times as high as with a potential difference of 60 Volts. In order to ascertain whether the nature of the glass might possibly be the cause of the phenomena, we have deposited the film on lead glass as well as on potassium-sodium glass, but in both cases found the same phenomenon.

A further phenomenon which was also observed with very thin films was as follows: a platinum film, about 3.5 μ thick, gave on repeated measurement a constant value for the resistance of 3.72×10^4 OHMS; after the glass cylinder being opened by which the air was admitted the resistance assumed a constant value of 3.15×10^4 Ohms. This observation perhaps indicates, that the presence of air or possibly of moisture might play a part in the change of the resistance of thin films with the time.

It is a great pleasure to us to express here also our thanks to Dr. G. L. F. PHILIPS w. i. for his very great interest and support in connection with our investigation. We also wish to thank Mr. M. P. DE LANGE who has assisted us with great assiduity.

Eindhoven.

*Physical Laboratory of the N. V. Philips-
Incandescent-lamp-factories.*

¹⁾ This result is not in accordance with SWANN's theory mentioned above.

KONINKLIJKE AKADEMIE VAN WETENSCHAPPEN
TE AMSTERDAM.

PROCEEDINGS

VOLUME XIX

N^o. 4.

President: Prof. H. A. LORENTZ.

Secretary: Prof. P. ZEEMAN.

(Translated from: "Verslag van de gewone vergaderingen der Wis- en
Natuurkundige Afdeling," Vol. XXIII and XXV).

CONTENTS.

- G. A. F. MOLENGRAAFF: "The Coral reef problem and Isostasy", p. 610.
- F. ROELS: "Some further Experiments on Inhibition Proceeding from a False Recognition". (Communicated by Prof. C. WINKLER), p. 628.
- H. ZWAARDEMAKER: "Radium as a Substitute, to an equiradio-active amount, for Potassium in the so-called physiological fluids; an experimental investigation in collaboration with Mr. T. P. FEENSTRA, assistant at the Utrecht Physiol. Lab." p. 633.
- F. E. C. SCHEFFER: "On the Influence of Temperature on Chemical Equilibria." (Communicated by Prof. J. D. VAN DER WAALS), p. 636.
- Mrs. E. J. HOOGENBOOM-SMID: "Comparison of the Utrecht Pressure Balance of the VAN 'T HOFF Laboratory with those of the VAN DER WAALS Fund at Amsterdam." (Communicated by Prof. P. ZEEMAN), p. 649.
- A. H. W. ATEN: "Some Particular Cases of Current potential Lines". I. (Communicated by Prof. A. F. HOLLEMAN), p. 653.
- M. J. VAN UVEN: "Skew Frequency Curves." (Communicated by Prof. J. C. KAPTEYN), p. 670.
- A. PANNEKOEK: "Calculation of Dates in the Babylonian Tables of Planets." (Communicated by Prof. E. F. VAN DE SANDE BAKHUYZEN), p. 684.
- A. SMITS: "On the System Mercury-Iodide." (Communicated by Prof. P. ZEEMAN), p. 703.
- A. SMITS: "On the Influence of the Solvent on the Situation of the Homogeneous Equilibrium." I. (Communicated by Prof. F. A. H. SCHREINEMAKERS), p. 708.
- F. A. H. SCHREINEMAKERS: "In-, mono- and divariant equilibria." XI, p. 713.
- L. RUTTEN: "Modifications of the facies in the Tertiary Formation of East-Kutei (Borneo)." (Communicated by Prof. A. WICHMANN), p. 728.
- H. A. LORENTZ: "Some remarks on the theory of monatomic gases", p. 737.
- H. A. LORENTZ: "On HAMILTON's principle in EINSTEIN's theory of gravitation", p. 751.

Geology. — “*The Coral reef problem and Isostasy*”. By Prof. Dr. G. A. F. MOLENGRAAFF.

Translated from the Dutch, somewhat revised and augmented.

(Communicated in the meeting of June 24, 1916).

The question of the origin of coral islands (barrier reefs and atolls) has of late been brought to the foreground again by the recent publications of DALY¹⁾ and DAVIS²⁾.

It is generally known that according to DARWIN's theory a considerable subsidence of the floor of the ocean over extensive areas is one of the necessary conditions for the formation of barrier reefs and atolls. While DARWIN's theory has maintained itself splendidly, at any rate in its main principle, against the numerous and manifold objections raised against it more especially after the Challenger expedition, still the great crustal movements which it requires always remained its weakest point which did not meet with general approval.

DARWIN³⁾ speaks expressly of real subsidence of the floor of the ocean itself, from which the coral formations, barrier reefs and atolls, rise. This real subsidence is very considerable; DANA⁴⁾, in connection with DARWIN's theory of the coral islands, assumed that since the tertiary period in the Pacific alone a region extending over 15 to 30 million square kilometres must have sunk 1000 to 1600 metres.

Depressions on such a scale of a considerable portion of the earth's crust, although not impossible, are not very likely⁵⁾. They have

1) R. A. DALY. Pleistocene glaciation and the coral reef problem. Amer. Journ. of Science 4, XXX, p. 297, 1910, and The glacial-control theory of coral reefs. Proc. of the Amer. Acad. of Arts and Sciences 51, p. 157, 1915.

2) W. M. DAVIS. A SHALER memorial study of coral reefs. Amer. Journ. of Science 4, XL p. 223, 1915.

W. H. DAVIS. The origin of coral reefs. Proc. Nat. Acad. of Sciences. I. p. 146, 1915.

— Extinguished and resurgent coral reefs. Proc. Nat. Acad. of Sciences. II. p. 466, 1916.

— The origin of certain Fiji atolls. Proc. Nat. Acad. of Sciences. II. p. 471, 1916.

— Problems associated with the study of coral reefs. The Scientific Monthly. II. p. 813, 1916.

3) CH. DARWIN. On the structure and distribution of coral reefs. Chapters V and VI.

4) J. D. DANA. Manual of Geology. Fourth, last edition 1896, p. 350.

5) It should be remarked that for the greater, central part of the Pacific all that is known until now about the relief of the bottom, tends to prove that this downward movement, if it has taken place at all, could not well have been compensated by a more or less equivalent upheaval of regions of comparable extent, since the atolls and islands encircled by barrier reefs in this ocean appear to stand on somewhat elevated strips of the bottom of the ocean, which are surrounded by still deeper basins. Compare: MAX GROLL. Tiefenkarten der Oceane.

remained a moot point and the papers published by DALY and DAVIS mentioned above deal mainly with this point, DAVIS' conclusion being that subsidence on a considerable scale, as postulated by the theory of DARWIN-DANA, is indispensable, while DALY on the contrary gives and upholds an explanation of the origin of coral islands in which subsidence of the floor of the ocean is *not* put forward as a necessary condition.

DAVIS, in his paper, has worked out a point of view to which DANA had first drawn attention. DANA¹⁾, independently, derived a strong argument in favour of DARWIN's theory and one which DARWIN himself had not yet used, from the contours and the relief of the islands which are surrounded by barrier reefs, and especially from the submerged or "embayed" valleys occurring on those islands.

DAVIS tested and verified the value of this argument by investigations in a large number of coral islands in the Pacific and proved that where barrier reefs occur, the fringed coasts are indented almost without exception and possess "embayed valleys".

Finally DAVIS by clear reasoning²⁾ arrives at the result that only the subsidence-theory of DARWIN and DANA leads to a satisfactory solution of the problem of the origin of barrier reefs and atolls.

DALY maintains, more emphatically than PENCK³⁾ had done before, that in the pleistocene period the storing of large quantities of water in circumpolar icecaps must have lowered the sea-level in aequatorial regions as much as 50 to 60 metres, which caused a corresponding equal lowering of the plane of abrasion and of the final base-level in those regions, whereas after the close of the glacial period a rise of the sea-level must have occurred of about the same amount caused by the melting of those icecaps. During this last rising of the sea-level or apparent subsidence of the land according to DALY and on account of it, the formation of the barrier

Veröff. des Inst. für Meereskunde. NF. A. 2. 1912. A non-compensated subsidence of such a considerable part of the Pacific since the tertiary period would have caused an apparent general rise of all continents — calculated from their present size — of about 120 metres. One might expect to find at least some indication of such an upheaval, but this is not the case.

1) J. D. DANA, in United States WILKES' Explor. Expedition, Geology p. 131, 1849, and W. M. DAVIS. DANA's confirmation of DARWIN's theory of coral reefs. Amer. Journ. of Science 4. XXXV p. 183, 1913.

2) Very interesting in this respect is DAVIS' preliminary paper, entitled: The Home Study of Coral Reefs. Bull. Amer. Geogr. Soc. Vol. XLVI. p. 561, 1914.

3) A. PENCK, Morphologie der Erdoberfläche III, p. 660, 1894.

PENCK thinks it possible that during and on account of the pleistocene glaciation the sea level has been lowered as much as 150 metres.

reefs and atolls took place. That such fluctuations of the sea-level, as DALY assumes, caused by the pleistocene glacial periods, have indeed taken place can hardly be doubted.

The remarkable shelf seas of the East Indian Archipelago, such as the Java sea and the Sahul bank, strongly support DALY's theory. From the geological structure of these two regions may be inferred that they have not been affected by the strong contrasting crustal movements which in recent geological times have either caused the very uneven relief and the complicated topography both of the land and the seabottom in the eastern part of the East Indian Archipelago or at any rate have made it much more prominent. The Java-sea is shallow¹⁾ and has a very constant depth which, on the average, does not deviate much from 50 and 60 metres, which is exactly the figure accepted by DALY for the rise of the sea-level (apparent subsidence of the land) in aequatorial parts since the pleistocene epoch. The same holds good for the Sahul bank. In both the Java-sea and the Sahul bank the bottom of the sea at present gives the impression of a submerged, strongly peneplainized land-surface. The mature forms of erosion which are met with on the islands of Bangka and Billiton, the Karimata islands and in West Borneo, which may be said to show a near approach to a peneplain, justify the surmise that those groups of islands are nothing but the harder more resistant parts or monadnocks left by erosion in the broad peneplain which in pleistocene times, the ocean-level being lowered, has been formed between the mountain-land of Sumatra and Java on the one hand and that of Borneo on the other. In late- and post-pleistocene times this peneplain has been submerged through the rise of the sea-level to a depth of some 50 to 60 m., by which submergence the present Java-sea was formed with its remarkably constant depths. In a similar way the Sahul bank was submerged along the north-west coast of Australia, a shelf thus being formed of equally remarkable constant depth.

In DALY's "glacial-control theory" a factor is brought forward for the origin of barrier reefs and atolls, which certainly has been of primary importance for the possibility of the formation of many of those types of coral-reefs.

Marine abrasion in the pleistocene period at lower sea-level,

¹⁾ Quite erroneously WEGENER quotes the floor of the Java-sea as an example of a shelf of great depth, according to him about 300 m. The words "Getreuer Querschnitt durch den 'Javaschelf'" (true section through the Java shelf) accompanying his figure 10, had therefore better been omitted. Compare A. WEGENER, *Die Entstehung der Kontinente und Ozeane*, p. 36, Braunschweig 1915.

followed by an apparent subsidence of the land caused by a rise of the sea-level, as DALY imagines, has created the conditions necessary for the origin of many barrier reefs and atolls; in a still larger number of coral reefs it has equally certainly determined their present shape as well as that of the submarine platforms from which they rise, and finally it has had its share in the formation of all of them.

Yet it appears to me not yet definitely proved that the "glacial control theory" is sufficient to explain the origin of all barrier reefs and atolls.

This theory gives no explanation of true or apparent subsidence of the land of considerably over 50 or 60 m., which must be admitted in order to explain the formation of several barrier reefs and atolls, e.g. of the numerous atolls which in the Pacific rise individually with very steep slopes from abysmal depths and do not stand connected with others on relatively shallow submarine platforms. True or apparent subsidence of the land of considerable amount is in my opinion indispensable for the explanation of the origin of those. In fact, for many islands surrounded by barrier reefs, a subsidence, certainly exceeding 60 m. must be inferred, with almost absolute certainty, according to DAVIS, from the occurrence and the shape of the "embayed valleys". Also, on the Funafati atoll the well-known boring in the lagoon has proved a subsidence of at least 75 m. and the boring on the reef there has made a subsidence of ± 340 m. probable.

To sum up I think we may conclude that the problem of the origin of the coral islands is at the present moment in this stage that it is pretty generally conceded that a subsidence of the ocean-bottom, either true or apparant, must be assumed for the regions where barrier reefs and atolls are found. Considerable uncertainty and diversion of opinion however still exists as to the amount and the cause of this subsidence.

A glance at a map showing the geographical distribution of coral-reefs shows that they occur in regions so much varying in geological structure that we can hardly expect the causes of subsidence to have been the same in all cases.

In fact subsidence of the land can be explained without much difficulty by crustal warping (or folding) where it is found to be restricted to the coasts of continents or to islands which are closely related to continents and rise from the same submarine platform as the continent does, as is the case in the southwestern part of the Pacific, which stands in close relation to the Australian continent.

The name south-western part of the Pacific I use here in denoting

the part, west of the Kermadec and Tonga deep-sea troughs (see fig. 1), i. e. exactly the part which GERLAND ¹⁾, with respect to its

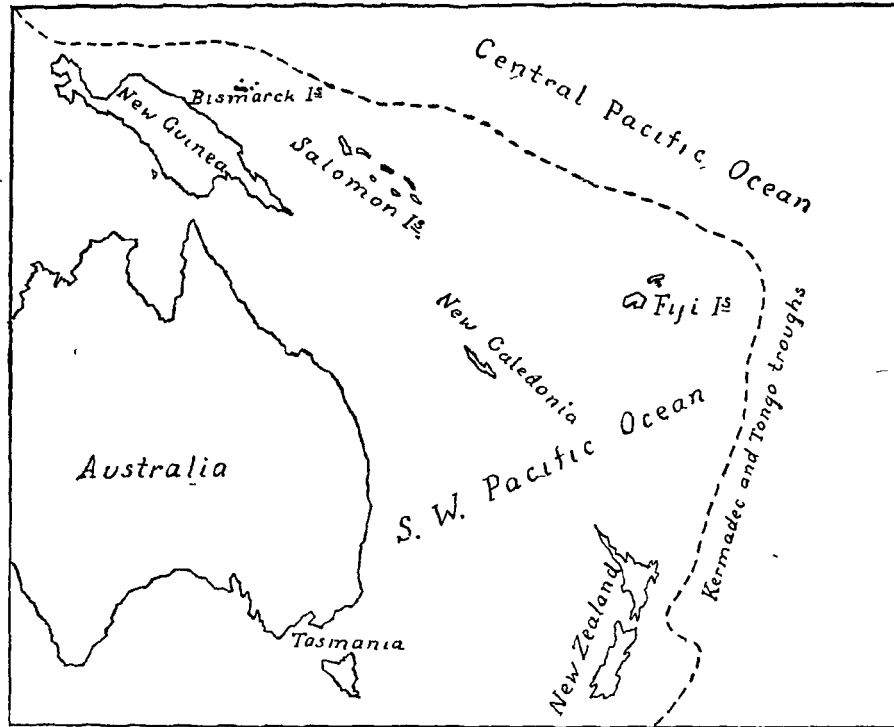

Fig. 1. -----Boundary-line between the southwestern and the central part of the Pacific Ocean.

structure, as the south-western part of the Pacific, contrasts to the north-eastern part, which I shall call the central part. MARSHALL ²⁾ also admits as the south-western border of the main (true, great or central) Pacific a line drawn along the Kermadec and Tonga troughs and from there along the north side of the Fiji archipelago, the New Hebrides, the Salomon Islands, etc.

Depressions, such as are found in this south-western part of the Pacific, appear to have been chiefly caused by crustal movements of opposite direction, so that a subsidence in one part of the region is more or less compensated by an upheaval in other parts. In this south-western part of the Pacific one finds, besides indications of

¹⁾ G. GERLAND, Vulkanistische Studien I. Die Korallen-inseln vornehmlich der Sudsee. Beitrage zur Geophysik II. p. 29, 1895.

²⁾ P. MARSHALL, Oceania, Handb. der 109. Geologie VII. Heft 2, p. 28 and 32, 1911.

very considerable subsidence, in many islands the proofs of recent very strong upheaval. In New Guinea tertiary deposits have been observed to occur on the highest mountain tops (Carstensz-top, 4780 m., and Wilhelmina-top 4750 m.) and in the group of the Fiji islands ¹⁾ some regions have in recent times been raised 300 m., while parts only a few kilometres distant show traces of strong subsidence and submergence.

As to the real or apparent subsidences of lesser or larger extent in true oceanic regions, not compensated by counter-movements, such as are generally assumed to have taken place in the Central Pacific as well as in the Indian Ocean and also in a small part of the Atlantic, no satisfactory explanation of their mode of origin has as yet been given and great uncertainty continues to prevail on this head.

Now it is clear, that, before we try to suggest any explanation, the question has to be considered how far the assumption of the subsidence of true oceanic islands is supported by facts. Such consideration proves that although the assumption of subsidence is indirectly supported by the convergent evidence of many facts, yet until now, only one fact is known, which gives direct evidence of subsidence and, consequently, disappearance below the sea-level of an oceanic island.

This fact is the subsidence recently proved with certainty by boring on the island of Bermuda. Bermuda-Island is the only oceanic island in the Atlantic lying within the limits of the geographical distribution of the reef-building corals. Bermuda-Island, or the group of the Bermudas, is at the surface entirely composed of reef-limestone. It rises on a submarine bank or shoal which is strongly elongated in a south-east and north-west direction. This shoal is 51 km. long at a depth of 100 fathoms and is surrounded on all sides by a sea of an average depth of 4500 m.

The deep boring referred to was made in the island in the year 1912 at a point situated 42 m. above sea-level. It proved that Bermuda Island consists of a volcanic mountain, built up of a series of superposed banks of basaltic volcanic material, the probably truncated top of which now lies somewhat more than 75 m. below sea-level.

On this truncated cone or platform rests the so-called Bermuda limestone, a reef-limestone extending upwards to the surface of the sea, the portion of the island projecting above the sea also consisting of it.

¹⁾ E. C. ANDREWS. Relations of coral reefs to crust movements in the Fiji-islands. Amer. Journal of science. XLI. p. 141, 1916.

The lowest and oldest part of this cap of limestone is of late-eocene or early oligocene age. PIRSSON¹⁾, who examined the boring material, was able to prove that in eocene time Bermuda Island projected from the sea as a volcanic island and that, probably after the volcanic activity had subsided, it was wholly or partially truncated by wave-action. During that process and afterwards the island gradually sank to a depth of somewhat more than 75 metres below sealevel and it was during this period of subsidence that the reef-limestone was built up on the top of the sinking island. The limestone probably always reached about to the surface of the sea and hence grew thicker at the same rate as the island subsided.

The fact that in some hills the Bermuda reef-limestone is now situated over 40 m. above the sea, proves that the subsidence did not proceed continually without true or apparent opposite movements²⁾. The main movement, however continued to be downward. It first made itself felt probably in pre-eocene times and has very likely amounted to some hundreds of metres in total.

A part of this movement, namely the portion that took place since the pleistocene period, has probably been caused by a rise of the sea-level as explained in DALY'S "glacial-control theory", but not the entire subsidence can be explained in this way. First, it is too great considering that the island lies at 35° N. lat., but moreover the movement had already begun in oligocene time, as PIRSSON shows. Besides in the same borehole at 290 m. (935 feet) below sea-level, volcanic material was met with again which proved to be well rounded by water and showed traces of subaerial weathering, which fact, even if it were supposed that here a part of a submarine gravel cone was struck, leads one to suppose that the island has subsided considerably more than 75 metres.

This borehole has revealed the fact that where nowadays Bermuda island rises from the ocean, submarine volcanoes once were active, of which finally one or more rose above the sea, that these volcanic islands gradually sank away and disappeared under the ocean-level since a period preceding the eocene and that their subsidence for a long time has been compensated by the accumulation of successive streams of basaltic lava. The layer struck in the borehole at a

¹⁾ L. V. PIRSSON. Geology of Bermuda island. Amer. Journ. of Science. XXXVIII. p 189, 1914.

²⁾ HEILPRIN estimates the average amount of the upheaval preceding the present condition of Bermuda Island at 80 feet at least. A. HEILPRIN, The Bermuda-islands. Philadelphia 1889, p. 46.

depth of 290 m., composed of material, showing the effects of sub-aerial weathering, proves that the island once rose above the sea, probably before the eocene period. In eocene times or shortly afterwards this was again the case but later the volcanic activity ceased and the gradual subsidence was then no longer compensated by the accumulation of volcanic material; consequently the volcanic cone ultimately disappeared below the sea and now lies at 75 m. below sea-level, covered by a cap or crown of reef-limestone which nowadays rises fairly high above the sea in some places. In spite of the upheaval proved by this latter fact this remarkable boring justifies the conclusion that the general trend of the movement of the oceanic volcanic group of the Bermudas has for a long period been downward.

What may be the cause of such downward movements?

It seems to me that from the theory of isostasy we can make some deductions, suggesting a possible or even probable explanation.

The doctrine of isostasy developed from a hypothesis (PRATT'S hypothesis) to a well-founded theory by numerous investigations, especially by HECKER and HAYFORD, presupposes that on the average the mass of the terrestrial crust is heavier under the oceans than under the continents.

It may be assumed that the outer crust of the earth consists chiefly of sediments and other rocks of an average density of $\pm 2.6-2.8$, of which gneiss and granite are the principal types, grouped together by SUSS as *sal* and sometimes also called lithosphere in a more restricted sense, while under this acid crust a shell of more basic rocks follows with an average density of ± 3 , to which SUSS has given the collective name *sima*, and which is also named *barysphere* in contradistinction to lithosphere. Basalt is a type of these latter rocks and the whole *sima* has been called by DALY "basaltic substratum".

In order to explain isostasy we might imagine that the outer acid crust is thicker under the continents than under the oceans, but it may also be supposed that this lighter granite-gneiss crust also comprising all sediments excepting the thin pellicle of oceanic (pelagic) sediments, does not form a closed shell round the terrestrial globe, but is in general restricted to the continents, so that under the oceans the *sima* or basaltic substratum must immediately follow under the certainly not very thick cover of oceanic sediments.

This second explanation is considered the more likely one by

DALY¹⁾; it has been especially brought to the fore by WEGENER²⁾ and is also accepted by ANDRÉE³⁾ and DACQUÉ⁴⁾.

From it follows that the continents must be considered as flows of salic composition, floating in the sima in the same way as icebergs do in water, being submerged⁵⁾ with about 95% of their mass.

Moreover the very fact of the existence of isostasy everywhere on earth, as proved by the observations and considerations of HECKER, HELMERT and HAYFORD, leads to the conclusion that the sal as well as the sima, as soon as the masses are considerable, behave under the influence of gravity like bodies with some degree of plasticity⁶⁾ and that this plasticity is somewhat more developed in the sima than in the tougher sal. It is exactly through this plasticity, however small it may be, that isostasy is maintained and that notwithstanding various geological factors which continually disturb the isostatic equilibrium the isostatic compensation is even at the present day still fairly well complete in most places on earth.

Smaller masses, however, are often not compensated. The Olympus mountain range e.g. in the state of Washington shows a fairly great positive anomaly of the value g , i.e. of gravity. Now this range stands upon and in the salic block of the American continent, which has sufficient rigidity to bear and support this isostatically non-compensated body. It may be assumed that isostatically non-compensated nuclei on or in the continental blocks can remain very long in a condition of apparent stability.

The matter is quite different, however, for true oceanic islands, i.e. islands whose base is not connected with any continental block. Such islands rise directly from the ocean-bed and have never formed part of any continent.

¹⁾ R. A. DALY. *Igneous rocks and their origin*, 1914, p. 164.

²⁾ A. WEGENER. *Die Entstehung der Continente und Oceane*, p. 19. Braunschweig 1915. WEGENER on pp. 15—19 pleads convincingly in favour of this view. WEGENER had already published the main outlines of his hypothesis in the *Geologische Rundschau* III, 1912, p. 276.

³⁾ K. ANDRÉE. *Ueber die Bedingungen der Gebirgsbildung*, p. 32, Berlin 1914.

⁴⁾ E. DACQUÉ. *Grundlagen und Methoden der Palaeographie*, p. 96, Jena 1915.

⁵⁾ This simile has also been used by PICKERING and later again by WEGENER l. c. p. 19.

⁶⁾ CHAMBERLIN compares the plastic yielding and consequent lateral horizontal outward flow of the continental masses ("outward creep of the continents") under the influence of gravity so far as the character of the movement is concerned, with the behaviour of glacier-ice under the same influence.

T. C. CHAMBERLIN. *Diastrophism and the formative processes III*. *Journal of Geology*. Vol. XXI, p. 577—587, 1913.

These islands as far as they are not composed of reef-limestone, are found to consist, exclusively of volcanic material, as a rule of basaltic or allied rocks¹). The non-volcanic or not entirely volcanic islands in the Pacific are restricted to the south-western part which stands in close relation to the Asiatic and Australian continents, while on the other hand not only in the Pacific, but also in the Atlantic all true oceanic islands are composed of volcanic rocks.

Such true oceanic islands, as far as they have been studied, are not isostatically compensated and, without exception, show a larger or smaller positive anomaly of gravity²).

The position of these islands is exceptional, resting immediately on the sima and being rooted into it, and not being supported by much larger masses of salic material, by continental blocks, as is the case with the incompletely-compensated or non-compensated nuclei in and on the continents.

It appears to me that, on account of the isostasy itself, these volcanic islands, rising directly from the plastic sima as cones or groups of cones of considerable bulk, cannot always remain in existence³); under the influence of gravity they will without exception yield and sink down slowly but gradually and if this movement is not counteracted by other forces they must disappear below the sea and finally approach more and more the form of the ocean-bed, being welded again with and incorporated in the sima below the ocean bottom.

In such islands conditions must be exceptionally favourable for the formation of barrier reefs and in case of total submergence, of

¹) The reader is referred to: G. GERLAND. Vulkanistische Studien. I. Die Koralleninseln der Südsee. Beiträge zur Geophysik. II. 1895, p 29-34, where in a convincing discussion it is rendered all but certain that all coral islands of the central Pacific rest on a volcanic base; and R. A. DALY. Problems of the Pacific Islands Amer. Journal of Science XLI, 1916, where on p. 153 it is pointed out that the statements about non-volcanic continental rocks occurring in some of these islands are not certain and require revision.

²) E. BORRASS. Bericht über die relativen Messungen der Schwerkraft mit Pendelapparaten in der Zeit von 1808 bis 1909. Verh. der 16ten Allg. Konferenz der internat. Erdmessung III. Berlin 1911.

³) WEGENER (l. c. p. 13) probably had this idea in his mind and it evidently led him to suppose that these volcanic oceanic islands should in reality be isostatically compensated, although the contrary has been proved, and that they could not well be entirely composed of volcanic material but ought to contain a nucleus of salic (continental) material, which should be relatively very large, since about 95% of it must be hidden under the sea-floor immersed in the sima. In my opinion these suppositions being, contrary to all observed facts, must be regarded as exceedingly improbable.

atolls. As a matter of fact within the geographical limits of the reef-building corals exactly these islands are almost without exception surrounded by barrier-reefs and the great majority of the atolls occur exactly in the same areas where both volcanic islands and barrier-reefs are found.

In appears to me that the yielding and slow sinking of the volcanic islands under the influence of gravity.¹⁾ must be regarded as the cause of the downward movement of large amount and long duration which must be assumed in order to explain the formation of barrier-reefs and atolls in true oceanic regions, the cause of which had as yet not been ascertained.

By accepting this hypothesis which restricts the subsidence to the islands themselves and their direct basements²⁾ and does not postulate large crustal movements nor great displacements of masses, one can meet the most serious of the objections, raised against the theory of DARWIN-DANA, even by its adherers, which were mentioned in the beginning of this paper.

It is clear that the rate of sinking of all volcanic oceanic islands will always depend on the local composition of the island and of the sima of the underground and that moreover by various influences this movement can be counteracted either really or apparently.

Thus the subsidence can temporarily be counteracted *in reality* by diastrophism and also by variations of the sea-level, as e.g. by the general lowering of the sea-level in early pleistocene times, to which PENCK and later especially DALY in his "glacial control theory" have drawn attention; *apparently* it can be counteracted by prolonged volcanic activity, by which such islands might gain

¹⁾ The effects of crustal warping of the ocean floor caused by diastrophism e.g. by folds, will have just as little chance to remain in existence. After having been formed the elevated portions will yield and sink away again by the influence of gravity, although in all probability very slowly.

²⁾ G. GERLAND in his very important paper cited above also assumes that not the floor of the Pacific itself has subsided. He wants to restrict this downward movement to the tops of the volcanoes which, as he thinks, may move upwards as well as downwards under volcanic influence. Compare l. c. p. 56: "Senkung und Hebung der Koralleninseln sind Erscheinungen gleicher Art und zwar beide Erscheinungen, welche dem Vulkanismus der Erde angehören". (Sinking and rising of the coral islands are phenomena of the same order, both of them belonging to terrestrial volcanism). He does not try to explain the cause of the subsidence of the volcanic cones, although he takes subsidence to be well proved. He remarks on this point l. c. p. 66: "Das Sinken zu erklären vermag ich nicht; man gestalte mir nun, auf einzelne hierhergehörige und, wie mir scheint, sichere Thatsachen hinzuweisen". (The subsidence I cannot explain; I only beg to draw attention to facts pointing to it which I regard as well established).

in height more by the repeated accumulation of fresh volcanic products than they lose by the slow process of plastic subsidence.

By way of summary, it seems to me that the following conclusions are justified:

In order to explain the formation of barrier-reefs and atolls it is imperative to accept that a subsidence of the land (incl. islands) with respect to the sea-level took place in those regions where they occur, and to explain the formation of very many of these reef-structures in oceanic regions it is equally urgent to look upon this subsidence of the land with respect to the sea-level as having been considerable and to have extended over a long period.

Three cases may be distinguished:

1. The subsidence is the result of crustal movements. Such crustal movements will have been the ruling factors where barrier-reefs are found along the coasts of continents or where barrier-reefs and atolls are found encircling islands which on account of their structure and composition are closely related to neighbouring continents, i.e. in the not truly oceanic regions, as e.g. the whole south western part of the Pacific. These crustal movements¹⁾ have very likely always had a compensatory character; subsidence of a certain amount in one region being compensated by upheaval of corresponding amount in neighbouring regions and vice versa;

2. The subsidence of the land is only apparent and caused by positive movements of the sea-level, such as e.g. must have taken place in the late and post-pleistocene periods and probably still continue to some extent at the present day as the result of the melting of icecaps which in the pleistocene glacial period had accumulated on the continents - the importance of which movements for the origin of numerous barrier-reefs and atolls has been convincingly shown in DALY's repeatedly mentioned theory;

3. The subsidence of the land is a real one, caused by the plastic yielding of isostatically non-compensated parts of the terrestrial crust in true oceanic regions under the influence of gravity, just as, according to the theory of isostasy, must be expected to occur in all true oceanic volcanic islands. This subsidence may be very considerable and will in fact only stop when such an island has entirely or nearly sunk away into the sima of the ocean-bed or rather will

¹⁾ The author, besides the generally accepted orogenetic and epirogenetic movements, also admits the possibility of horizontal movements of continental blocks such as WEGENER assumes in his bold hypothesis about the origin of the continents and oceans.

A. WEGENER, Die Entstehung der Kontinente und Ozeane. 1915. Kapitel 5 und 6.

have been recombined with it. Such a movement involves that as a last trace, bearing witness to the former existence of such an oceanic volcanic island, the spot where it once stood can be indicated by an atoll, rising from the bottom of the ocean to the surface. Obviously such an atoll will only be formed if there is a certain ratio between the rate of subsidence of the island and the upward growth of the reefs, whereas moreover the reef must have grown uninterrupted during the whole period of downward movement.

This harmonic ratio will of course exist in rare cases only and it is to be expected that in many of the sinking oceanic islands the contact with the sea-surface will have been broken, which the upward growing corals are always trying to keep up. It is clear, moreover, that the majority of the bodies built up by submarine volcanic activity will have sunk back again without ever having reached the surface. We may therefore expect that the vestiges of submarine volcanic activity nowadays mainly will be found as a ridge or elevation¹⁾ of inferior depth to the surrounding sea extending longitudinally in the direction of that line of least resistance of the terrestrial crust, along which the volcanic material was ejected. On this gentle ridge submarine hills must be found, formed by volcanic masses, in all stages of slow subsiding. Here and there from the same ridge atolls will rise up to the surface as colossal reef-built structures, while in other spots, where the volcanic activity lasted longer or still continues, volcanic masses will be found to protude above the level of the ocean to the present day as mountainous islands, surrounded by barrier reefs.

The above hypothesis does not give a satisfactory explanation of the upheavals which occasionally for a time interrupt the process of subsidence and cause some true oceanic coral islands to project fairly high above the sea. In comparison with the overwhelming large number of coral islands for which no rise can be demonstrated, the cases of rising observed are so few that DARWIN, in my opinion rightly, drew the conclusion that the positive movements observed represent oscillations only in a direction opposite to the general downward trend.

From the hypothesis outlined above, some stringent deductions

¹⁾ Such submarine ridges of very feeble relief are indeed indicated on the already cited excellent "Tiefenkarte der Oceane" by MAX GROLL. From the most north eastern of these ridges in the Pacific the Sandwich Islands rise above the sea-level.

follow, which will serve to some extent to test its probability. Some of these may be briefly mentioned here.

When a volcanic island, crowned with some form of reef structure sinks down, it may happen, as has been stated above, that the upward growing reef-building corals do not succeed in the long run in keeping in contact with the superficial layers of the ocean which alone present the conditions necessary for their existence. As soon as they have sunk down below the limit of depth down to which reef-building corals can live, they will no longer be able to grow further but together with their basement of volcanic origin they will continually sink deeper and die off. If this be true we may expect to find such sunken reefs at very different depths within the area of the reef-building corals. As far as I know, it has never been described up to the present that in the Pacific fragments of reef-building corals have been dredged from great depths which could not in all likelihood be considered as originating from neighbouring coral islands rising above the sea. But this cannot be wondered at since the number of deep-sea dredgings is not large and next to nothing when we think of the extensive area we have to deal with, so that the chance must be extremely small, that a point where portions of a drowned coral-reef occur, will be hit exactly. Outside of the Pacific, however, viz. in the Ceram Sea, a fact¹⁾ has occurred which I consider very important.

I mean the dredging No. 177, made on Sept. 1, 1900, by the Siboga²⁾ in the middle of the Ceram Sea³⁾. From a depth ranging from 1633 to 1304 m. over a distance of no less than three nautical miles large quantities of recent reef-building coral were then dredged, which

¹⁾ After this paper had been read, a second instance came to my notice through the courtesy of Mr. J. W. VAN NOUHUYS, who informed me, that in the year 1914, when commanding the ship *Telegraaf* of the Government Navy in the Netherlands East Indies he brought to the surface from a depth of 1500 m. some pieces of coral reef limestone at a spot, situated about 30 nautical miles from the nearest shore, of the island of Engano. The exact spot where this deep-sea sounding took place is 5°33' Lat. and 102°45' Long.

²⁾ It is also possible that similar finds have been made elsewhere by deep-sea expeditions but have not been recorded. Very remarkable are the results obtained in the year 1899 by the steamer *Albatross* at the stations Nos. 35, 489 and 112 near the Paumotu archipelago, where from depths of 1462, 1123 and 1568 fathoms resp. so called coral sand was dredged; no coral islands lie at a smaller distance from there than $\frac{1}{3}$ degree latitude.

A. AGASSIZ. The coral reefs of the tropical Pacific p. 25, fig. 2 and Plate 201. Mem. of the Museum of compar. Zoology at Harvard College XXVIII, 1913.

³⁾ See Siboga expedition. Vol. I. M. WEBER. Introduction et description de l'expédition p. 80, 1902.

had died off and by a thick cover of manganese revealed their long stay in the sea-water after their dying off. The nearest point in these regions where living reef-building corals occur near the surface lies at 42 kilometres from the point where the dredging took place, so that those deep-sea corals could not originate there. In order to explain the result of this dredging I should rather suppose that on that spot in the Ceram Sea from the sea-bottom which lies at a depth of about 1600 m. a drowned coral island rises to about 1300 m. below sea-level. Such a supposition seems justified if it is borne in mind that the Ceram Sea is one of the most remarkable trough-shaped deep basins in the eastern part of the Indian Archipelago, the origin of which is probably connected with crust-movements in pleistocene and post-pleistocene times. They were formed by downward movements, simultaneous with and more or less compensated by elevations of about equal amount of other parts — nowadays highly elevated islands — in that region. Now a fairly large number of cases has already become known which render it probable that subsidence caused by diastrophism¹⁾, such as took place in the Ceram Sea, can proceed relatively quickly, which is very likely not the case where islands subside through yielding to the influence of gravity — isostatic subsidence — which is to be assumed in the central Pacific. Thus the chance that coral islands may be drowned must be esteemed larger in the former case which is present in the Ceram Sea than in the latter.

Perhaps the remarkable dredging N^o. 177 of the Siboga expedition may become the starting point for an explanation of the interesting fact that although the deep sea-basins in the eastern part of the East Indian Archipelago, have been formed by depressions of large amount in pleistocene and post-pleistocene times, reef-structures of the type of the barrier reefs and atolls, certainly within those basins occupy a very modest place.²⁾

A second consequence of the outlined hypothesis is that it must not only hold good for the true oceanic volcanic islands in the Pacific but also for those in the Indian Ocean and the Atlantic. Now it is certainly remarkable that for the only true oceanic island which in the Atlantic is found within the area of the reef-building

¹⁾ Very interesting are the examples of important differential movements by diastrophism since post-pliocene times which LAWSON mentions of the coast and coastal islands of Southern California. A. C. LAWSON, The post-pliocene diastrophism of the coast of Southern-California. Bull. of the Dep. of Geology. Univ. of California I, p. 115, 1893.

²⁾ Compare J. F. NIEMEYER, Barrière-riffen en atollen in de Oost-Indische archipel. Tijdschr. Kon. Ned. Aardr. Gen. 2. Vol. XXVIII, p. 377, 1911.

corals, namely Bermuda¹⁾, it has recently been proved (see above) that the reef limestones which nowadays project there above the sea are the upper portion of a cap or crown of reef-limestone, which is at least 110 m. thick and rests on a sunken basaltic mountain.

All other true oceanic volcanic islands in the Atlantic lie outside the area of the reef-building corals. They are all volcanic²⁾ and are situated on the so-called mid-Atlantic ridge ("Mittelatlantische Bodenschwelle"). The Canary and Cape Verd Islands certainly and the Selvagen Islands and the Madeira Group probably are not true oceanic islands, but have once formed part of the European-African continent³⁾.

Perhaps we may see in this remarkable mid-Atlantic ridge the final result of volcanic activity along an enormous fracture of the same extent, where from numerous fissures and vents volcanic material was discharged, thus a volcanic mountain chain and cones being formed, which nowadays subside through yielding under the influence of gravity and nearly all have sunk back to a level approaching the average level of the deep submarine ridge. Here and there a few islands, where volcanic activity lasted longer or has existed to this day, still rise above the sea⁴⁾ and others (of which

¹⁾ The West Indian archipelago proper with its numerous coral islands and reef-formations does not belong to the group of true oceanic islands. West India is a region of strong and recent diastrophism, intimately related to the American continent.

²⁾ GAGEL mentions the occurrence of numerous loose boulders of gneiss and granite on Santa Maria, one of the Azores, and adds that these rocks are not indigenous there, but probably have been carried thither during the pleistocene glacial epoch by icebergs. C. GAGEL, Die mittelatlantischen Vulkaninseln. Handb. der region. Geologie VII. H. 10, p. 12, 1910.

The evidence considered as acceptable by SCHWARZ for the occurrence of non-volcanic (continental) rocks in some of these islands, is, to quote his own words, "not so good as one could wish for, and could not be admissible were the islands more easy of access, or had a geologist been to the place himself".

E. H. C. SCHWARZ. The rocks of Tristan d'Acunha, brought back by H. M. S. Odin, 1904 with their bearing on the question of the permanence of ocean basins. Trans. of the S. A. Phil. Soc. Vol XVI, p. 9, 1905.

³⁾ C. GAGEL. l. c. pp. 31.

⁴⁾ The fact, that several of the volcanic islands in the Atlantic, as e.g. Nightingale island and Tristan d'Acunha, are very well cliffed, appears to afford a strong argument against my hypothesis which requires slow but continuous subsidence for these islands also. This argument, however, loses its strength, if it is borne in mind, that the process of cliffing by wave-action is a *rapid* one, especially on these volcanic islands, which are partly composed of incoherent or little coherent eiacamenta (or efflata), and, their coasts not being protected by fringing reefs, are exposed on all sides to the full fury of the mid-ocean waves. The process of sub-

naturally only a few have been discovered accidentally by soundings) still rise to different heights above the average level of the ridge but no longer attain the surface of the sea. Among these latter we mention three submarine mountains¹⁾ which near the western part of the Azores rise from the bottom of the ocean, which has there a depth of about 3000 m., to respectively 146, 128 and 88 m. below sea-level. The cause for the extrusion of such enormous masses of volcanic material might perhaps be sought in the disruption of the American continent from the European-African one with which it formerly cohered. This disruption was assumed by PICKERING²⁾ and TAYLOR³⁾ and a plea for it is again brought fore by WEGENER on page 68 of his paper quoted before. On this supposition the mid-Atlantic ridge would in my opinion indicate the place where the first fissure occurred and the sima was first laid bare. From this it would follow logically that the ridge itself must consist entirely of sima and not of sal, as WEGENER assumes on page 69.

Finally it may be remarked that according to the hypothesis put forward in this paper it is not possible that deposits formed on the floor of true oceanic regions will ever be definitely raised above sea-level and so partake in the building up of continents. In accordance with this is what experience had until now taught about the occurrence of fossil deep-sea deposits on the continents⁴⁾. Although their occurrence there is much less limited than is generally supposed, they are exclusively found in geosynclinal regions, i.e. in parts which once, before their folding and forcing up, were deep troughs at a relatively small distance from the edges of continents and by no means true oceanic regions.

A P P E N D I X.

After this paper had been read, the following contributions to our knowledge of the question at issue came to my notice.

sidence caused by plastic yielding under the influence of gravity, on the contrary, is a *slow* one. Thus, notwithstanding their slow subsidence these islands may show well developed cliffs by the action of the waves.

¹⁾ C. GAGEL. l.c. p. 9.

²⁾ W. H. PICKERING. The place of origin of the moon. Journ. of Geol. XV. p. 23, 1907.

³⁾ F. S. TAYLOR, Bearing of the tertiary mountain-belt on the origin of the earth's plan. Bull. Geol. Soc. of America XXI, p. 179, 1910.

⁴⁾ G. A. F. MOLENGRAAFF. Over oceanische diepzeeafzettingen van Centraal Borneo. Versl. Afd. Nat. d. Kon. Akad. van Wet. Amsterdam Dl. XVII. p. 83, 1909. (On oceanic deep-sea deposits in Central Borneo. These Proceedings XVII, p. 141.

1. R. A. DALY. A new test of the subsidence theory of coral reefs. Proc. of the Nat. Acad. of Sciences of the U. S. of America. Vol. II p. 664, 1916.

In this paper DALY argues that the observed shallowness of the lagoons as well as the levelness of the great majority of the lagoon-floors do not seem to agree with a legitimate deduction from the subsidence theory of coral reefs, whereas the glacial control theory would afford a reasonable explanation. It seems to me even if we accept the glacial control theory, the principle of subsidence in accordance with DARWIN's theory need not necessarily be abandoned.

An atoll, e. g. the Funafuti atoll, may have been formed under conditions of local subsidence in accordance with the hypothesis explained above, in a time preceding the pleistocene glacial period. During the glacial period the atoll with its moat more or less filled may have been truncated in consequence of the lowering of the sea-level to a level about 50—60 metres below the present sea-level. By this truncation the lagoon-floor attained its levelness, which it has on an average maintained until the present day, although on its rim a new growth of corals has since the close of the glacial period again built up an atoll-shaped reef structure, the visible portion of which determines the shape of the present Funafuti-atoll.

2. A. LACROIX. Le soi-disant granite de l'île Bora-Bora. C. R. des séances de la Soc. Géol. de France. Séance du 18 Décembre 1916, p. 178.

In this paper LACROIX proves that the supposed granite (according to Ellis) of the island of Bora-Bora in the group of the Society Islands, is in reality not a granite at all, but a medium-grained olivine-gabbro, an intrusive facies of a basaltic rock, of which the greater part of the island consists.

Bora-Bora is a true oceanic island encircled by a beautiful barrier reef and if it were indeed composed of granite this fact, to quote LACROIX, „entraînerait d'importantes conséquences au point de vue théorique”.

LACROIX, however, now has done away with the myth of the occurrence of granite in the Society Islands, and the island of Bora-Bora thus only confirms the rule, which we have accepted, that true oceanic islands are composed of volcanic rocks.

Experimental Psychology. — “*Some further Experiments on Inhibition Proceeding from a False Recognition.*” By Dr. F. ROELS. (Communicated by Prof. C. WINKLER).

(Communicated in the meeting of September 30, 1916).

In our previous paper “On Inhibition Proceeding from a False Recognition” (These Proceedings Vol. XVIII, p. 1412) we pointed out that a memory-image of a stimulus, either entirely or partially inaccurate, exerts on its recognition at some later time an inhibition revealing itself in a complete or partial sensation of novel experience for the primary stimulus, whereas there is no inhibition in the case of an inaccurate image of imagination. We also presumed that the absence of a distinct inhibition to the recognition of stimuli, that had been altered objectively at their second presentation, was to be ascribed to the absence of a false recognition in the interval. (Cf. *Ibid.* p. 1222).

This has been confirmed by a new series of experiments in so far as it appeared that false recognitions of objectively altered stimuli could only rarely be evoked experimentally, but also that, when we did succeed, the false recognition of the objectively altered stimulus exerted an inhibition similar to that of the inaccurate memory-image. The course of our researches was, on the whole, regulated as before, viz. the stimuli were coloured, meaningless, more or less complex figures on cardboard discs, 10×10 cm. During the sitting intended for the impression of the stimuli, a dozen of such figures were, in succession, presented to the observer in a tachistoscope of our own making, the exposure of each figure lasting about 750 σ . Each set was shown five times to two of our observers — W. and D. —. With M. we had to confine ourselves to three presentations as a larger number appeared to inhibit false recognitions. At a second sitting, 24 hrs. after the first, 7 or 8 stimuli were given under the same conditions. They resembled more or less some of the first set in form and colour. Our aim was to arouse false recognitions of the objectively altered stimuli in order to establish any possible action upon the subsequent recognition of the primary stimuli. In order to prevent the observer from expecting exclusively the exhibition of altered figures a number of primary figures, — together with some entirely new ones — were again exposed to view.

At the third sitting — again 24 hrs later — the primary figures were again shown, together with some new ones, so that the observer

was unable to know beforehand whether the stimulus, presented to him, was or was not one of the impressed set.

The reaction-times of the second and the third sittings were registered by means of HIPP's chronoscope; the observer, who had held down a MORSE-key with one of his forefingers before the stimulus came into view, let it go the moment he attended to the stimulus. The clock, which had commenced to go as the figure came into view, then stopped.

The chronoscope, which was attended to prior to every sitting, showed for 300 control-tests distributed over 30 days a mean deviation of 1.35 σ .

The following table shows the distribution of the stimuli over the three sittings:

TABLE I.

1st Sitting	2d Sitting	3d Sitting
180 figures	108 objectively altered figs 32 primary figs 40 new figs	108 primary figs, corresponding with the 108 altered figs of the 2d Sitting. 40 primary figs, belonging to the 32 primary figs not shown at the 2d Sitting. 32 new figs.

We failed to evoke a large number of false recognitions. Only in 5—7% of the cases did the altered figures of the 2^d sitting arouse a complete or a partial false-recognition. It should be observed that we took into account only those cases, in which the observers reported unhesitatingly a recognition of entirely or partially altered figures.

The following table gives for each of the three observers the percentage of the false recognitions compared with those of the cases, in which the alteration was reported determinately, or led to failure of recognition, or set up a sensation of novel experience. The last column comprises the percentages of the cases in which the observers could not clearly substantiate their recognition of the figures shown. In our calculations we started from 100 successful experiments with the altered figures of the 2^d sitting. Owing to accessory circumstances — fatigue, lack of concentration etc. of the observers — we had to set aside for M., W. and D. respectively 8, 8 and 13 cases.

TABLE II.

	Number of successful experiments.	False recognitions	Alteration recognised	Alteration not recognised, or sensation of novel experience	Doubtful cases.
M	100	7	56	28	9
W	100	5	50	40	3
D	95	5.3	40	54.7	—

The inhibition of the false recognition to the subsequent recognition of the primary figures was noticed in all cases. Forms and colours that had been altered for a second sitting and that led to a false recognition, aroused a sensation of novel experience. In 17 cases that were observed, there was only one in which the primary figure did not arouse a sensation of novel experience. There was complete lack of recognition. The only alteration the primary figure underwent in this case, concerned one colour. Two of D's cases very clearly demonstrate the inhibition proceeding from a false recognition. In either there was a false recognition of the forms and colours of an altered figure; the recognition was, however, more or less doubtful, so that later on the sensation of novel experience, aroused by the primary figures, was also doubtful.

These results appear to us to prove that the false recognition of stimuli, altered objectively in the interval, are answerable for a similar inhibition to that of the inaccurate memory-images, which were examined in our previous experiments.

The primary figures, the alteration of which was recognized at the second sitting, were, in most cases, recognized completely when exhibited again. In the following table we give the percentages of the cases in which the primary figure, altered and recognized in the interval, was recognized completely, or partially, or gave rise to a sensation of novel experience:

TABLE III.

	Complete recognition	Partial recognition	Complete sensation of novel experience
M	88.4	10.2	1.7
W	96	4	—
D	76.3	23.7	—

The primary figures, the alteration of which was neither recognized, nor was followed by a sensation of novel experience, but the altered aspect of which, as a whole, was not recognized or produced a sensation of novel experience, were recognized in the vast majority of the cases at a later presentation. In comparatively few cases did they evoke a partial or complete sensation of novel experience. We record in Table IV the percentages of the cases of recognition and of partial or complete sensation of novel experience. It clearly shows that the fading of the memory-image of the primary figure during the interval cannot be made responsible for the sensation of novel experience that almost always occurs at a false recognition of the stimulus that has been altered objectively at the 2nd sitting. (See Table I).

TABLE IV.

	Recognition of primary figure	Partial sensation of novel experience	Complete sensation of novel experience
M	60	23.3	16.7
W	72.5	15	12.5
D	65.5	23	11.5

A safer criterion is found in the frequency of the recognition of primary figures, which had not been inhibited in the interval by a false recognition and had not been influenced favourably by a repeated impression. (See Table I 3rd Column). Table V illustrates the percentage of the cases in which these figures produced at the third sitting a recognition either complete or partial or a sensation of novel experience:

TABLE V.

	Complete recognition	Partial recognition	Sensation of novel experience
M	88.6	8.6	2.8
W	94.2	2.9	2.9
D	91.4	8.6	—

The foregoing data appear to us to warrant the following conclusion: A false recognition of an objectively altered stimulus exerts upon the subsequent recognition of the primary stimulus an inhibition that reveals itself in a sensation of novel experience for the

primary stimulus. This sensation must not, anyhow not in our experiments, be ascribed to the influence of the time that has elapsed since the impression.

An analysis of the reaction-times of the 3rd sitting confirms this conclusion. We have calculated the arithmetical mean, the mean deviation and the median for the reaction-times of the third sitting in the case of a false recognition in the interval, in that of recognition of the primary figures of which the alteration at the second sitting was recognized or evoked a sensation of novel experience, and in the case of recognition of the figures, impressed only at the first sitting. Finally we also calculated the reaction-times for the entirely new figures (Vexirversuche). They always invoked a sensation of novel experience, except in five cases with *D.*, in which was reported: "not recognized". These times have been tabulated in thousandths of seconds:

TABLE VI.

		Arithm. mean	Mean dev.	Median
I. False recognition	M	674	—	—
	W	4028	—	—
	D	870	—	—
II. Alteration recognized	M	563	81	557
	W	1956	950	1550
	D	709	166	658
III. Alteration arouses s. of novel exp. or is not rec.	M	702	116	656
	W	1974	784	2045
	D	828	142	832
IV. Figures impressed only at 1st sitting	M	531	83	490
	W	1424	739	1036
	D	647	136	651
V. New figures	M	622	89	611
	W	1045	292	860
	D	854	206	787

These data appear to us to clearly demonstrate that the inhibition, proceeding from the false recognition in the interval, exerted upon the recognition of the primary stimulus, manifests itself also in the reaction-times. A comparison of the latter in the case of false recognition with those for the figures, the alteration of which was recognized in the interval (I and II) reveals that this inhibition is not insignificant with each observer. This appears still more clearly from a comparison of the times of I and IV, since the figures, shown only at the first sitting, were not under the influence of inhibition in the interval.

The fact that the time, required for recognition, in the case of a recognized alteration in the interval (II) is much shorter than the time needed for a sensation of novel experience (III) evoked for the altered figure, is easily accounted for by the circumstance that, owing to the novel sensation evoked by the figure, the experiencing person could not associate this figure with the primary one, which he could indeed when recognition of the alteration occurred.

Physiology. — *“Radium as a Substitute, to an equiradio-active amount, for Potassium in the so-called physiological fluids; an experimental investigation in collaboration with Mr. T. P. FEENSTRA, assistant at the Utrecht Physiol. Lab.”* By Prof. H. ZWAARDEMAKER.

(Communicated in the meeting of Sept. 30, 1916).

Considering that potassium is the only radio-active element always present in the animal body, I suggested to Mr. T. P. FEENSTRA, about a year ago, to ascertain whether potassium could be replaced by other radio-active elements in non-toxic doses. It afterwards appeared that similar experiments had been performed on rubidium by S. RINGER, after whom the physiological solutions, in use nowadays, are generally named, when he expressed the relation of all the salts of the MENDELEJEFF-group (to which potassium belongs) to potassium salts, in equimolecular ratios. Mr. FEENSTRA, while abandoning the molecular ratios, followed quite a different method, viz. he measured the doses of his elements upon the basis of radio-activity, being fully alive to the responsibility for the view-point which he thereby assumed.

This bold, at all events extraordinary method of observation led in a few months to the results published in the communications of

April 28 and May 27, 1916¹⁾, in which the elements K., Rb., U., and Th. have been mutually compared. Their doses in the physiological solutions, used by FEENSTRA are in the ratios of their *total*²⁾ radio-activities. The experiments were performed chiefly upon the frog's heart. It kept beating for hours in every one of the solutions, just as with the best prepared RINGER's mixture, in common use.

From the very beginning we have, moreover, proposed detecting at the same time any antagonism for the salts, in which the radioactive elements are used. Antagonism was found indeed and appeared to be primary, i.e. it concerns the system in which the excitability of the heart muscle arises automatically and spreads, for the antagonism affects the electrocardiogram as well as the myogram. Besides all reactions are reversible.

Finally the element Radium has also been examined in the same way.

The apparatus were arranged as before. A frog's heart, removed from the body, was first fed for fifteen minutes by means of a KRONECKER cannula with normal RINGER's mixture (NaCl 0.7 %, KCl 0.01; CaCl₂ 0.02; NaHCO₃ 0.02, glucose 0.1), to enable it to restore itself. Subsequently Potassium-free RINGER's mixture was given until, after a short retardation and irregularity, a standstill ensued. Only in the third place followed the administration of a potassium-free RINGER's mixture to which radium-bromide had been added to an amount, which, as far as its total radioactivity is concerned, may be considered about equal to the amounts of K., Rb., U., and Th., used in previous experiments.

The radium at the disposal of Mr. FEENSTRA was obtained of the Radiogen-Gesellschaft, branch-office at Amsterdam and was equal to 1000 Mache-units per litre of the original fluid. In the 7 cc. mixed with one litre of potassium-free RINGER's mixture this corresponded with about 3 micromilligrams ($3 \cdot 10^{-9}$ gram).

The small quantity of the solution supplied by the Company, which was to be one of the constituents of the circulating fluid, was neutralised beforehand and the fluid was used immediately afterwards in order to prevent a slow precipitation of the radium-salt in unacidulated fluids³⁾.

Thus we invariably succeeded in 10 + 3 experiments in making

1) T. P. FEENSTRA, See these Proceedings Vol. 24 p. 1822; Vol. 25 p. 37 1916.

2) Total radio-activity after RUTHERFORD's data in MARX's Hdb. d. Radiology, Vol. 2 p. 519, 525; the measurement for Potassium and Rubidium was performed according to data found here and there in the book.

3) A. S. EVE, Amer. J. of Science (4) Vol. 22, 1906 p. 4

the heart resume its beats after it had been brought to a standstill by the potassium-free RINGER's mixture. About 15 minutes after the radium-circulation has commenced maximal contractions occur at irregular intervals at first, but presently they become as rhythmic as previously in the same heart. If the radium-RINGER's mixture is replaced by potassium-free RINGER's mixture the radium-pulsations persist another hour or so. Finally the heart stops beating again. By applying radium-containing fluid again the beats recommence deliberately within a few (3--10) minutes. On the other hand, when administering normal RINGER's mixture a radium-heart's action is arrested abruptly, from which it recovers only after an hour. These results are quite in accordance with those previously obtained with uranium and thorium and which were then considered to be due to the accumulative effect of the hardly diffusible ion and the rapidly incoming potassium-ion. The question of antagonism, being theoretically a matter of great moment, is kept back for a later paper. Thanks to Prof. SCHOORL's kindness we were also now in a position to determine any accidental amount of potassium both in the radium-fluid and in the reagents. In all cases a Litre of potassium-free, resp. radium-containing circulating fluid contained less than 2.5 mgrms of potassium, an amount which, of itself, is incapable of maintaining the heart-beats, as has been shown in frequently repeated experiments.

In three experiments the emanation was removed from the radium solution used for the preparation of the circulating fluid (first by boiling, then by neutralising)¹⁾. In these cases also we succeeded in making the heart resume its beats; with a well-measured dose this was even effected perfectly in the normal space of time.

It is evident, therefore, that Potassium, Rubidium, Uranium, Thorium, and Radium can replace each other, as far as the heart is concerned, in the RINGER-circulating fluid, provided that doses are taken in proportion to their total radio-activity. With all of them the recovery of the cardiac action as well as its toxic inhibition occur in the same way. The most normal doses are: (See page 635).

I beg leave for the present to merely make mention of the facts detected. It goes without saying that they give ample scope for far-reaching speculations, but I wish to postpone them, as new experiments are being made, which, I feel confident, will throw more light upon these results.

As observed above, potassium is the only radio-active element that plays a part in ordinary life. It is very likely, however, that an important rôle is played only by the free, mobile potassium, that

¹⁾ RUTHERFORD in MARX's Hdb. d. Radiologie Bnd 2 S. 422.

Metals used	$\frac{\text{litre-dose}}{\text{mol. weight}}$	salt-dose ¹⁾ in mgr. per litre	metal-dose in mgr. per litre	total radio- activity per gramm per seconde	$\frac{\text{metal-dose}}{\text{atom weight met.}} = a$	$a \times \text{tot. rad.}$ in mgr. p. sec.
Potassium (as Pot.-chloride)	1.34	100	53	0.3×10^{-1} erg.	1.5	0.000045
Rubidium (as Rubidiumchloride)	1.20	150	105	0.7×10^{-1} erg.	1.2	0.000084
Uranium (mostly as uranyl- nitrate)	0.063	25	15	0.8 erg.	0.06	0.000048
Thorium (as Thoriumnitrate)	0.10	50	24	0.3 erg.	0.1	0.000030
Radium (as Radiumsalts)	1×10^{-8}	5×10^{-6}	3×10^{-6}	1.38×10^6 erg.	1×10^{-8}	0.000019

occurs in the animal circulating-fluids and in the tissue-fluids, and that, carried along by ions, may adhere to the cells.

Utrecht, 28 September 1916.

Chemistry. — “*On the Influence of Temperature on Chemical Equilibria*”. By Dr. F. E. C. SCHEFFER. (Communicated by Prof. J. D. VAN DER WAALS).

(Communicated in the meeting of Sept. 30, 1916).

1. *The expression for the influence of temperature on equilibria.* When in a rarefied gas mixture or a diluted solution a chemical reaction is possible, there exists a definite relation between the concentrations of the reacting substances in the state of equilibrium. The “constant of equilibrium”, the value of the product of the concentrations of the substances of one member of the reaction equation, divided by that of the concentrations of the substances of the other member, in which every concentration is raised to the power of which the exponent gives the number of molecules taking part in the conversion, is constant at a definite temperature, but

¹⁾ The salt doses in RINGER’s mixture give some scope for variation, also when the Calcium-content is permanent; the values given are those actually used by us.

varies at changing temperature. The dependence on the temperature is expressed by VAN 'T HOFF's well known expression:

$$\frac{d \ln K}{dT} = - \frac{E}{RT^2} \dots \dots \dots (1)$$

in which K represents the constant of equilibrium, T the absolute temperature, E the energy of conversion, and R the gas constant¹⁾.

If one wants to apply this equation to definite cases, it must be integrated; for this purpose we should know E as function of the temperature.

If one takes a constant for E , in other words if the change of energy in the reaction is independent of the temperature, if therefore, the sum of the specific heats of the substances of the first member of the reaction equation is equal to that of the substances of the second member, we get by integration of equation 1 an expression of the form:

$$\ln K = + \frac{a}{T} + b, \dots \dots \dots (2)$$

in which a and b represent constants.

If we assume that the algebraic sum of the specific heats of the reacting substances is not *zero*, as was supposed in (2), but has a value that does not vary with the temperature, the change of energy is linearly dependent on T ; then equation 1 gives on integration:

$$\ln K = + \frac{a}{T} - b \ln T + c, \dots \dots \dots (3)$$

in which a , b , and c indicate again constants.

If the specific heats vary linearly with T , we obtain a quadratic expression for E ; integration of (1) then yields:

$$\ln K = + \frac{a}{T} - b \ln T - cT + d \dots \dots \dots (4)$$

I have already pointed out before that equation (2) is sufficiently in agreement with the measurements of the equilibrium for many gas reactions²⁾. As was said above, this expression holds perfectly accurately only when the algebraic sum of the specific heats of the reacting substances is *zero* at all temperatures. This is certainly not the case in general; the influence of the specific heats is, however, so small for almost all equilibria that the mistake made by neglecting it, is much smaller than the inevitable errors of observation. Hence

¹⁾ If in K the concentrations of the second member are in the numerator, then E is the loss of energy at the reaction.

²⁾ These Proc. XV, p. 1116.

it appears in the application of equation 2 that almost all the chemical equilibria may be just as well represented by this expression as by the more complicated expressions 3,4 etc., which are pretty well universally used in the literature. This fact justifies in my opinion the preference of equation 2 to the others on account of its simplicity.

In perfect harmony with this appears also the fact that the observations of chemical equilibria have never been executed accurately enough to make calculations of the specific heats of the reacting substances possible.

If now the specific heats were well known through direct measurement, it would be rational to take them into account when drawing up the equation of equilibrium. For this purpose we want, however, the specific heats of *all* reacting substances, as only the algebraic sum plays a part in the equation of equilibrium. Generally, however, the specific heats of only a few substances are sufficiently known, and that at temperatures which deviate from those at which the measurements of the equilibrium have been carried out. Besides, for dissociating substances a direct measurement of the specific heat is impossible exactly in consequence of this decomposition. Generally no sufficient data are therefore available for the specific heats to justify the drawing up of an equation of equilibrium which contains more terms than equation 2.

That the influence of the specific heats is so small that equation 2 can just as well be used as 3, 4 etc., may seem astonishing at first sight. I explained the reason of this already before¹⁾; in the following paragraph I shall elucidate this question in a somewhat different and perhaps more intelligible way.

But it is not only for the sake of its simplicity that I prefer equation 2 to all the others. In the literature many equilibria have been described which are indicated by expressions which are more complicated than equation 2. Now there are two cases possible. Either the observations can just as well be represented by the formula with two constant quantities, or they cannot. In the latter case we have to do with very great errors of observation. The great advantage of 2 is that it draws our attention to these errors. If equation 2 cannot be used, the observations must be repeated.

I will demonstrate in the following pages by a number of examples that equation 2 is just as suitable as the more complicated equations and at the same time I shall show of some other equilibria

¹⁾ These Proc. XV, p. 1114 et seq.

which cannot be represented by equation 2 that this is owing to great inaccuracies in the determinations. I shall then also have an opportunity to call attention to a few important reactions, which in my opinion have been observed little accurately, and of which a renewed examination is very desirable.

2. To begin with I will make clear why equation 2 is applicable almost without exception to the material of experimental facts, and I will illustrate this by a gas equilibrium which is one of the most accurately investigated equilibria, viz. the carbonic acid dissociation: $2 \text{CO}_2 \rightleftharpoons 2 \text{CO} + \text{O}_2$. If we call E_{T_1} the change of energy on conversion of two gram-molecules of carbonic acid at the temperature T_1 , it is represented at another temperature T by:

$$E_T = E_{T_1} + (c_1 - c_2)(T - T_1), \quad \dots \quad (5)$$

in which c_1 represents the mean specific heat at constant volume of two gram-molecules of carbonic acid, and c_2 of two gram-molecules of carbonic oxide and one gram-mol. of oxygen between the temperatures T and T_1 . If the true specific heats are no functions of the temperature, and the mean specific heat is none either, then equation 1 yields after substitution of E_T according to 5 on integration

$$\begin{aligned} \ln K &= \int \left[-\frac{E_{T_1}}{RT^2} - \frac{c_1 - c_2}{RT} + \frac{c_1 - c_2}{RT^2} T_1 \right] dT = \\ &= \frac{E_{T_1}}{RT} - \frac{c_1 - c_2}{R} \ln T - \frac{c_1 - c_2}{RT} T_1 + C_1. \end{aligned}$$

This equation can be transformed into:

$$\ln K = \frac{E_{T_1}}{RT} + \frac{c_1 - c_2}{R} \ln \frac{T_1}{T} - \frac{c_1 - c_2}{R} \frac{T_1 - T}{T} + C. \quad \dots \quad (6)$$

If we now write $\ln \frac{T_1}{T} = \ln \left(1 + \frac{T_1 - T}{T} \right)$ in a series, we get:

$$\ln K = \frac{E_{T_1}}{RT} + \frac{c_1 - c_2}{R} \left[\frac{T_1 - T}{T} - \frac{1}{2} \left(\frac{T_1 - T}{T} \right)^2 + \dots \right] - \frac{c_1 - c_2}{R} \frac{T_1 - T}{T} + C. \quad (7)$$

The first term of the series disappears, so that equation 7 can be written:

$$\ln K = \frac{E_{T_1}}{RT} - \frac{c_1 - c_2}{2R} \left(\frac{T_1 - T}{T} \right)^2 + \dots + C. \quad \dots \quad (8)$$

The term of the series which has the greatest influence, has disappeared; equation 2 is obtained from (8) by neglect of the higher terms. And these are generally small. The observations of the carbonic acid equilibrium have been carried out between 1300

and $1565^\circ K$. If now for T_1 , 1400° is chosen, we shall make an error of:

$$\frac{0.003 (c_1 - c_2)}{R} \text{ resp. } \frac{0.006 (c_1 - c_2)}{R}$$

on omission of the correction term of 8 at the highest and the lowest temperature.

If we now consider that c_1 is about $6 R$, c_2 $7\frac{1}{2} R$, and $c_1 - c_2$ amounts therefore to $-\frac{3}{2} R$, the errors in $\ln K$ become 0.005 resp. 0.009, in K 0.5% resp. 0.9%. At the intermediate temperatures the errors are smaller. As now errors of several percentages are not rare, the deviation keeps far within the errors of observation when the correction term in question is neglected.

On an earlier occasion I calculated the expressions of the carbonic acid equilibrium by the aid of the best known data for the specific heats for another purpose¹⁾. The equations used had the following form:

$$\log K_p = -\frac{29530}{T} + 2.92 \log T - 0.001419T + 1.61 \cdot 10^{-7}T^2 + 1.75 \quad (9a)$$

$$= -\frac{29600}{T} + 2.93 \log T - 0.001286T + 1.61 \cdot 10^{-7}T^2 + 1.57 \quad (9b)$$

$$= -\frac{29570}{T} + 2.59 \log T - 0.001362T + 1.74 \cdot 10^{-7}T^2 + 2.71 \quad (9c)$$

$$= -\frac{29600}{T} + 1.75 \log T - 0.00066T + 4.73 \quad (9d)$$

$$= -\frac{29500}{T} + 2.5 \log T - 3 \log \left(1 - e^{-\frac{4050}{T}} \right) + \\ + 2 \log \left(1 - e^{-\frac{992}{T}} \right) + 4 \log \left(1 - e^{-\frac{2350}{T}} \right) + 2.25 \quad (9e)$$

$$= -\frac{29490}{T} + 2.5 \log T - \frac{3}{2} \log \left(1 - e^{-\frac{5630}{T}} \right) \left(1 - e^{-\frac{5630}{2T}} \right) + \\ + \log \left(1 - e^{-\frac{1800}{T}} \right) \left(1 - e^{-\frac{1800}{2T}} \right) + 2 \log \left(1 - e^{-\frac{2920}{T}} \right) \left(1 - e^{-\frac{2920}{2T}} \right) + 2.22 \quad (9f)$$

The simple equation 2 yields, when the constant is taken in partial pressures:

$$\log K_p = -\frac{28800}{T} + \log T + 5.59 \quad (9g)$$

In the table on the next page I have combined the observed equilibrium values and the deviations yielded by the expressions 9a—g.

¹⁾ These Proc. XIV, p. 747 et seq.

TABLE I.

T	$\log K_p$	$9a$	$9b$	$9c$	$9d$	$9e$	$9f$	$9g$
1300	-13.45	0	-0.03	0	0	-0.01	-0.01	0
1395	-11.84	-0.07	-0.08	-0.07	-0.07	-0.07	-0.07	-0.08
1400	-11.77	-0.05	-0.06	-0.06	-0.05	-0.05	-0.05	-0.06
1443	-11.11	-0.08	-0.09	-0.10	-0.09	-0.09	-0.09	-0.10
1478	-10.79	+0.07	+0.07	+0.07	+0.06	+0.07	+0.07	+0.06
1498	-10.28	-0.18	-0.18	-0.18	-0.18	-0.17	-0.17	-0.18
1500	-10.50	+0.06	+0.08	+0.08	+0.07	+0.07	+0.07	+0.07
1565	-9.88	+0.26	+0.28	+0.27	+0.26	+0.28	+0.28	+0.26

It will be clear from this table that the six expressions $9a-f$, which in the most accurate way take the specific heats into account, and the formula $9g$, in which the specific heats do not occur, represent the observations equally well. The sum of the deviations in absolute value is successively:

0.77, 0.87, 0.83, 0.78, 0.81, 0.81, and 0.81.

This example shows clearly that the said deviations must be attributed to errors of observation, and that a change in the specific heats has not much influence on the equilibrium expression.

3. The hydrogeniodidedissociation.

On a former occasion I discussed this equilibrium at length, taking the specific heats of the substances taking part in the reaction, into account ¹⁾. My purpose was then to test an expression derived by Prof. VAN DER WAALS JR. for the gas dissociations. I have now also examined whether the simplest expression (equation 2) can be applied to this equilibrium. If we graphically represent $\log K$ as function of T^{-1} , and if we draw a straight line through the points as well as is possible, we find:

$$\log K = -\frac{600}{T} - 0.856 \dots \dots \dots (10a)$$

In table II the values yielded by this expression, are compared with those that follow from the formula derived before:

$$\log K = -\frac{529}{T} - \log \left(1 - e^{-\frac{972}{T}} \right) - 1.079 \dots \dots (10b)$$

¹⁾ These Proc. 17, 1022, (1915).

and the formula proposed by NERNST:

$$\log K = -\frac{540.4}{T} + 0.503 \log T - 2.35. \quad (10c)$$

TABLE II.

T	$\log K$	$10a$	$10b$	$10c$	$\Delta 10a$	$\Delta 10b$	$\Delta 10c$
304.6	-2.925	-2.826	-2.798	-2.875	-0.099	-0.127	-0.050
328.2	-2.692	-2.684	-2.668	-2.731	-0.008	-0.024	+0.039
354.6	-2.416	-2.548	-2.542	-2.591	+0.132	+0.126	+0.175
553	-1.931	-1.941	-1.954	-1.947	+0.010	+0.023	+0.016
573	-1.905	-1.903	-1.914	-1.906	-0.002	+0.009	+0.001
593	-1.878	-1.868	-1.877	-1.866	-0.010	-0.001	-0.012
613	-1.851	-1.835	-1.842	-1.830	-0.016	-0.009	-0.021
633	-1.823	-1.804	-1.810	-1.795	-0.019	-0.013	-0.028
653	-1.794	-1.775	-1.778	-1.762	-0.019	-0.016	-0.032
673	-1.765	-1.748	-1.748	-1.731	-0.017	-0.017	-0.034
693	-1.735	-1.722	-1.719	-1.701	-0.013	-0.016	-0.034
713	-1.705	-1.698	-1.693	-1.673	-0.007	-0.012	-0.032
733	-1.675	-1.675	-1.667	-1.646	0	-0.008	-0.029
753	-1.644	-1.653	-1.642	-1.621	+0.009	-0.002	-0.023
773	-1.612	-1.632	-1.618	-1.596	+0.020	+0.006	-0.016
793	-1.580	-1.613	-1.595	-1.573	+0.033	+0.015	-0.007

The sum of the errors amounts successively to 0.414, 0.424, and 0.549. This table will in my opinion make it incontestable that pretty great experimental errors must occur in the observations and that these errors are large in comparison with those resulting from the neglecting of the specific heats. The first three observations have been made by STEGMÜLLER, the others by BODENSTEIN. Originally these latter observations were comprised by BODENSTEIN in the expression:

$$\ln K = -\frac{90.48}{T} - 1.5959 \ln T + 0.0055454 T + 2.6981. \quad (10d)$$

This expression is in very good agreement with his own observations. When however, we represent the values following from this expression, in the graphical representation $\log K = f(T^{-1})$, the line

exhibits an appreciable curvature. This is, indeed, also clear from table II, as BODENSTEIN's observations present a regularly changing deviation from expression 10*a*. This curvature is, however, not essential, and must be attributed to errors of observation, which appears clearly from this that expression 10*d* is entirely incompatible with the observations of STEGMÜLLER. Thus -2,19, -2,17, and -2,15 follows from 10*d* for the first three observations, whereas STEGMÜLLER found -2,925, -2,692, and -2,416. Here too we see therefore that the straight line 10*a* and the slightly curved lines 10*b* and 10*c*, represent the observations better than the more decidedly curved line 10*d*.

4. Of the gas reactions there is no example known to me for which the two-constant formula 2 expresses the observations less accurately than the more complicated formula; the influence of the specific heats is always small, and its influence is always exceeded by the errors of observation. This will no doubt be in connection with the fact that the algebraic sum of the specific heats can naturally be only small. In the two members of the reaction equation the same atoms, namely, always occur and only the different way of binding can bring about a difference in specific heat. If we imagine an equilibrium $A_2 \rightleftharpoons 2A$, the specific heat of the di-atomic molecule, when there is not yet an appreciable vibration in the molecule, will amount to $5 \times \frac{1}{2} R$, corresponding with the three degrees of freedom of the translation and two of the rotation (solid of revolution). The two free atoms have a specific heat of $6 \times \frac{1}{2} R$. The algebraic sum, therefore, amounts to $\frac{1}{2} R$. If we are at temperatures at which the vibration in the molecule becomes appreciable, then a value between zero and $2 \times \frac{1}{2} R$ must be added for the vibration (for the potential and the kinetic energy). The algebraic sum will therefore vary between $+\frac{1}{2} R$ and $-\frac{1}{2} R$. This small amount has hardly any influence on the chemical heat, and the same thing applies to the other gas equilibria in an analogous way.

A greater influence of the specific heats may be expected for the gas reactions, in which also solid substances take part. For then not only the different way of binding of the atoms, but also the difference in state of aggregation plays a part. In connection with the above I will, therefore, still discuss a few reactions with solid substances. In the literature there are described a number of equilibria, which would show a maximum or a minimum value for K at a definite temperature. It is clear that if this is true, the two-constant formula 2 cannot be applicable; this, namely, excludes the appearance of

‡1*

maxima and minima. I have examined these examples, and have arrived at the conclusion that a maximum or minimum occurs in none of these reactions, and the found particularities are exclusively the result of errors in the observations.

5. *The equilibria between the iron oxides.*

These equilibria play an important part in the blast-furnace processes. If carbon oxide is led over Fe_3O_4 , it is reduced to FeO , then to metallic iron. At a definite temperature an equilibrium can occur between Fe_3O_4 and CO on one side, and FeO and CO_2 on the other side. Likewise a second equilibrium is possible between $\text{FeO} + \text{CO}$ and $\text{Fe} + \text{CO}_2$. These equilibria have been examined by BAUR and GLÄSSNER, and they came to the conclusion that the constant of equilibrium $K = \frac{c_{\text{CO}}}{c_{\text{CO}_2}}$ possesses a maximum for the first equilibrium at a definite temperature, a minimum for the second at another temperature¹⁾. The found values have been reproduced in the graphical representation $\log K = f(T^{-1})$. (See fig. 1).

The curves which according to BAUR and GLÄSSNER represent the observations best, have not been indicated in the figure for the sake of clearness. Between the points found for the first equilibrium, indicated in figure 1 by triangles, a line was drawn by BAUR and GLÄSSNER with a strongly pronounced maximum; likewise a curve with a decided minimum through the crosses referring to the second equilibrium. The two lines traced in this way do not intersect; the irregular situation of the points allows of a pretty great freedom in the tracing of these lines. The two curves mentioned divide the field into three regions; above the line through the crosses metallic iron is stable, between the two curves FeO is stable and below the line through the triangles Fe_3O_4 .

The curve through the crosses ($\text{Fe} + \text{CO}_2 \rightleftharpoons \text{FeO} + \text{CO}$) presents a minimum at 680° ($10^4 T^{-1} = 10.493$); at this temperature the heat of conversion is therefore zero as appears from equation 1. BAUR and GLÄSSNER find resp. $+8724$ and -3114 cal. at 835° and 585° for the heat of transformation through calculation from their line. Hence the heat of transformation changes over a range of temperature of 250° by 11838 cal. This corresponds to an algebraic sum of the specific heats of 47.3 cal. Such a large sum is, however, impossible. We can make the following estimation of this sum. If KOPP's law is valid, Fe and FeO will differ about 4 calories;

¹⁾ Zeitschr. für physik. Chem. **43**, 354, (1903).

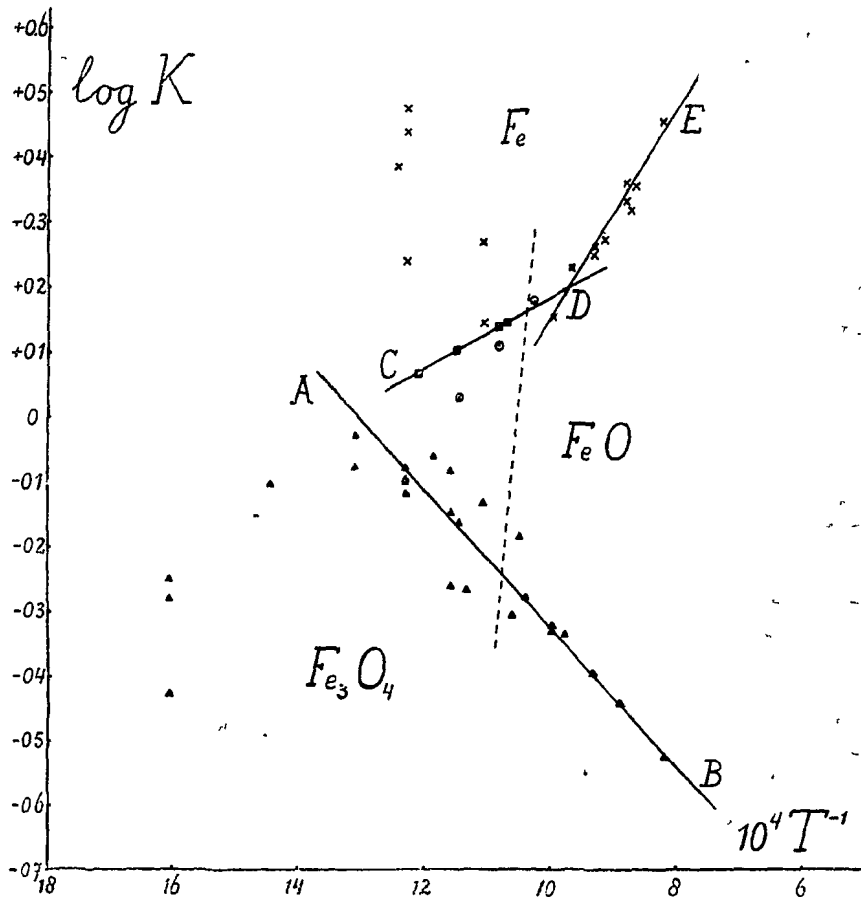

Fig. 1.

the difference between CO_2 and CO amounts to about 2 calories, and the algebraic sum of the specific heats amounts, therefore, only to some calories. A value of 47 must certainly be considered as impossible. We find something similar for the other equilibrium. At 490° the heat of transformation is zero ($10^4 T^{-1} = 13.106$). From the observations at 765° and 400° we calculate for the heat of transformation resp. -5176 and $+6563$ cal. The heat of transformation, therefore, changes over 365° by 11739 calories, which corresponds to a sum of specific heat of 32.2 calories. Theoretically we again expect a value of some calories. Hence there is no agreement here either.

If we now examine which determinations are the most reliable it is easy to see that it is certainly the observations at the highest temperatures. At lower temperatures the said equilibria are metastable with regard to carbon. The equilibrium $2\text{CO} \rightleftharpoons \text{CO}_2 + \text{C}$ yields a value for $\frac{c_{\text{CO}}}{c_{\text{CO}_2}}$, which is not constant at a definite tempe-

perature, but still depends on the total pressure; consequently in the graphical representation of fig. 1 not one line, but a series of lines, which each hold for a definite total pressure, are obtained for this equilibrium. If we now determine the situation of the line of equilibrium for one atmosphere total pressure in the graphical representation, it appears that it ascends very rapidly, and intersects the two lines of BAUR and GLÄSSNER. It is indicated dotted in figure 1. The equilibria on the left of the minimum and on the left of the maximum of BAUR and GLÄSSNER are metastable with respect to carbon; in this region carbon can be deposited; this can account for the branch of the Fe_3O_4 — FeO equilibrium that ascends towards the right, the more so as the setting in of the generator gas equilibrium is accelerated by iron oxides. Of the branch of the Fe — FeO -equilibrium descending towards the right no sufficient explanation is to be given in my opinion. The equilibrium $\text{FeO} + \text{CO} \rightleftharpoons \text{Fe} + \text{CO}_2$ has been later examined by SCHENCK; the minimum was not found back by him, his observations are indicated in fig. 1 by squares¹⁾. Through his points the line CD has been drawn. Also FALCKE's determinations²⁾ yield a line without minimum (in fig. 1 three points are indicated by circles), which, however, ascends more abruptly than CD and is in better agreement with the determinations at higher temperatures (line DE through BAUR and GLÄSSNER's points).

No other data of the equilibrium $\text{Fe}_3\text{O}_4 + \text{CO} \rightleftharpoons 3 \text{FeO} + \text{CO}_2$ are known to me than those mentioned by BAUR and GLÄSSNER. The line AB has been drawn as well as possible through the observations at the highest temperatures.

The remarkable conclusion to which these considerations lead, is that the lines for the two equilibria intersect. And this must be the case both when for the equilibrium $\text{FeO} + \text{CO} \rightleftharpoons \text{Fe} + \text{CO}_2$ we consider the observations of SCHENCK (CD) as accurate, and when we consider those of FALCKE (circles in fig. 1) and those of BAUR and GLÄSSNER at the highest temperatures (DE) as valid.

If this intersection occurs, it follows from this that *below the temperature of the point of intersection FeO must be a metastable compound.* This is easy to see, as in this point of intersection Fe , FeO , and Fe_3O_4 occur in equilibrium by the side of the gasphase, and there also exists, therefore, equilibrium between the three solid phases without gas. Hence at lower temperatures FeO will continue to be either metastable, or break up into $\text{Fe} + \text{Fe}_3\text{O}_4$.

Below the temperature of the point of intersection the equilibrium

¹⁾ SCHENCK, Ber. **40**, 1704 (1907).

²⁾ FALCKE, Zeitschr. f. Elektroch. **22**, 121, (1916).

$\text{Fe}_3\text{O}_4 + 4 \text{CO} \rightleftharpoons 3 \text{Fe} + 4 \text{CO}_2$ will then be stable. It would be desirable, in my opinion to test this conclusion experimentally.

If, therefore, the situation of the equilibria of the iron oxides with carbonic acid and carbon oxide is still insufficiently known, these equilibria are even quite in conflict with the determinations of DEVILLE and PREUNER¹⁾ concerning the reaction $3 \text{Fe} + 4 \text{H}_2\text{O} \rightleftharpoons \text{Fe}_3\text{O}_4 + 4 \text{H}_2$, which was studied between 200° and 1600°. It is clear that when the above interpretation is correct, this equilibrium must be metastable with respect to FeO at the higher temperatures; FeO may have been present in these determinations, and the observations may have been wrongly interpreted.

In conclusion it may still be said that v. JÜPTNER's calculations lead to the entirely divergent conclusion that FeO should be always metastable in the range from 600° abs. to 2400° abs. In these calculations use has, however, been made of uncertain data and uncertain hypotheses.²⁾

In his paper (These Proc. XIX, p. 175) Prof. REINDERS pointed out that the separation of iron carbide will give rise to new equilibria; this formation, can however in my opinion not affect the above conclusion. This will be clear on a consideration of fig. 10 of Prof. REINDERS's paper.

6. *The dissociation of ammonium bromide.*

In his researches on the homogeneous dissociation of the ammoniumhalides Prof. SMITH found a maximum at about 320° for the equilibrium constant of the ammonium bromide³⁾; above this temperature the dissociation constant diminishes at rising temperature. This decrease is very peculiar, as evidently no heat is required here for the splitting up of NH_4Br into NH_3 and HBr but heat is liberated. At the splitting up of a molecule into two it might be expected that energy was required to neutralise the chemical attraction.

At 320° the heat of transformation is zero as appears from equation 1. When the value of E is calculated from SMITH's line at the highest temperatures, 43000 cal. are found at the mean temperature of 384° C. Accordingly the heat of transformation varies over the range of 64° C. by 43000 cal., hence the algebraic sum of the specific heats is about 670 cal. A value is expected for this sum which will not be higher than about 10 calories and with the opposite sign, as it is the difference between the specific heat of a

¹⁾ PREUNER. Zeitschr. f. physik. Chem. **47**, 416 (1904).

²⁾ v. JÜPTNER. Theorie der Eisenhüttenprozesse (1907).

³⁾ SMITH Journ. Amer. Chem. Soc. **37**, 38 (1915).

hexatomic molecule and two tri-atomic ones. It can be directly derived from the number of degrees of freedom that a value of 670 cal. must be impossible. I think the conclusion must be drawn from this that in spite of the care devoted by Prof. SMITH to these measurements, the observations cannot be right or that they have been wrongly interpreted. The researches are very difficult, and an error in the observation passes into the value of the equilibrium constant greatly enlarged. The observations with ammonium chloride yield a normal behaviour in contrast with the just mentioned observations.

To prevent misunderstanding it may be pointed out that great specific heats can certainly occur, but that it must then be derived from that value that then a chemical reaction plays a part. Thus the specific heat of nitrogen-tetroxide is for instance very great; it can even amount to 100 cal. and more. This, however, is to be attributed to the decomposition of N_2O_4 into $2NO_2$. The specific heat of the equilibrium mixture, the composition of which varies with the temperature, is then e.g. 100 cal., but by far the greater part of this is caused by the shifting of the equilibrium with change of temperature and the great reaction energy attending it. If, however, we calculate the constant of equilibrium of the dissociation, we have no longer to do with the specific heat of the mixture, but with the algebraic sum of the specific heats, which is very small, also here. This also tallies with the fact that the dissociation constant of N_2O_4 in its dependence on the temperature can be represented by the two-constant formula 2, in which this sum is put zero.

If SMITH's experiments are correct, we should expect a second reaction, which has not been taken into account.

7. *The water gas equilibrium.*

The water gas equilibrium is also sometimes found mentioned as an example of a reaction with a maximum value of K . This conclusion, however, is not derived from direct observation, but rests on great extrapolation of data which are partly still little accurate. The observations have been carried out between 700° C.

and 1400° C.; calculated is a reversal of sign of $\frac{d \log K}{dT}$ at about

2800° C.¹⁾ No straight line can be drawn through the observations in the graphical representation $\log K = f(T^{-1})$; only the points which are given as little accurate, however, deviate appreciably from the straight line through the other points. Besides, at the temperature where this equilibrium would present this peculiarity,

¹⁾ HABER. Thermodyn. techn. Gasreakt.

the reacting substances themselves would be subjected to new decompositions, and the realization of the phenomenon would be excluded.

8. Conclusions.

At the present state of our knowledge of the gas equilibria every gas reaction may be represented by the two-constant formula

$$\log K = \frac{a}{T} + b.$$

There are no reasons to add more terms with T to this expression in the second member, as the experimental errors are always greater than the change that can be effected by these T -terms in the formula. If the addition of these terms is necessary, and if they, therefore, bring about an appreciable modification in the curve, we have to do either with a wrong interpretation or with errors of observation.

In contradiction with what is recorded in the literature, the transition case of $\frac{d \log K}{dT} = 0$ has not been found with any certainty for a single reaction, and it will not be easy to realize either in my opinion. This case might be found for a reaction that has a very small heat of conversion over a very great range of temperature; an example of this is, however, not known.

Physics. — “*Comparison of the Utrecht Pressure Balance of the VAN 'T HOFF Laboratory with those of the VAN DER WAALS Fund at Amsterdam.*” By Mrs. E. I. HOOGENBOOM—SMID. VAN DER WAALS fund researches N^o. 9. (Communicated by Prof. P. ZEEMAN).

(Communicated in the meeting of Sept. 30 1916).

Introduction. In the former half of 1915 a comparison was made of the small Amsterdam pressure balance with the open standard manometer at Leiden from 20 to 100 atmospheres¹⁾. The result of this was that the effective area appeared to be not equal to the real area; a constant value was not even found, but a value dependent on the pressure.

To be able to make accurate determinations of the pressure in spite of this it is required to study the theory of the instrument.

¹⁾ See C. A. GROMMELIN and Miss E. I. SMID, Comparison of the pressure balance of S. and B. etc. These Proceedings XVIII, p. 472.

For this purpose it was interesting to investigate whether the deviations of the effective area from the real area presented the same course for different pressure balances. We might obtain some idea of this by comparing the pressure balance of Prof. COHEN at Utrecht with the small and the large pressure balance belonging to the apparatus of the VAN DER WAALS fund, which comparison took place at Amsterdam from October to December 1915.

Investigation. The Utrecht pressure balance looks entirely the same as the small Amsterdam one, only the real area is not 1, but $\frac{1}{4}$ cm², so that its range of measurements reaches to 1000 atmospheres. The comparison of the effective area of the two apparatus was carried out by using a measuring tube filled with hydrogen, as it has been described by WALSTRA in his Thesis for the Doctorate¹⁾, as indicator. Then the measuring tube was successively brought in connection with the two pressure balances that were to be compared, the temperature of the gas being kept constant as well as possible at 25°. The results of the measurements at different pressures for different fillings in different measuring tubes on the given data are recorded in the following two tables.

TABLE I.

Ratio effective area Amst small and Utrecht press. bal.

Charge in kg.	14 Oct.	15 Oct.	16 Oct.	19 Oct.	20 Oct.	27 Oct.	16 Nov.	18 Nov.
88						3.993		
109	3.993		3.993					
147							3.993	
151	3.993	3.992	3.993					3.992
167						3.991		
195	3.993	3.991	3.991					
204							3.991	
223								3.992
242	3.990	3.991	3.991	3.991	3.990			

¹⁾ K. W. WALSTRA, Dissertate Amsterdam 1914. Cf. These Proc. Vol. 16, (1913) p. 754 and 822, Vol. 17, (1914) p. 203.

TABLE II
Ratio effective area Amst. large and Utr. press. bal.

Charge in kg.	19 Oct	20 Oct.	21 Oct	23 Oct.	25 Oct	29 Oct.	6 Nov.	8 Nov	9 Nov	10 Nov.	12 Nov.	13 Nov.	18 Nov	19 Nov.	20 Nov.
223															3.993
238										3.993					
242	3.996	3.993													
268						3.994									
297	3.997	3.996	3.993												
316													3.993		3.994
322									3.994	3.994					
351											3.994				
357			3.994		3.992										
398						3.992									
406											3.994				
420								3.994	3.994	3.994					
422				3.993											
440														3.993	3.994
471				3.993	3.993										
472											3.994				
533												3.994			
555						3.993	3.994								
566														3.993	3.994
592												3.994			
655												3.994			
668														3.994	3.994
701								3.993	3.994						
709												3.994			
751												3.993			
754							3.993								
796														3.994	3.993
894									3.994						
918														3.993	

Remarks.

1. The height of the piston appears to have an appreciable influence on the pressure. This influence was not observed at Leiden in experiments made expressly for the purpose.

2. The rotatory velocity has an appreciable influence on the pressure.

3. The direction of rotation has a great influence on the pressure with the Utrecht pressure balance. The difference amounts to about 60 grams for a charge of 60 kg. When the charge is very slight, the Utrecht balance can only be rotated in one direction. Hence only the charge for righthand rotation is always taken into account on comparison with the small Amsterdam balance. On comparison with the large balance on Oct. 19 and 20 the Utrecht balance was either rotated to the left or to the right, because then the phenomenon had not yet been observed. Afterwards always the mean has been taken of the charge for lefthanded and righthanded rotation.

Result. The ratio of the effective areas appears to be pretty well constant, taking into consideration the inaccuracy which is the consequence of the phenomena mentioned in the above remarks. On comparison of the Utrecht pressure balance with the small Amsterdam balance, however, the ratio values seem to present a slight systematic course.

It is the intention to continue the investigation of the pressure balance in the Amsterdam laboratory, first of all in this direction that the value of the effective area will be determined for very different values of the charge. The apparatus required for this will, however, most likely not be obtainable during the war.

In conclusion I must express my indebtedness to Prof. KOHNSTAMM, under whose superintendence I have been allowed to carry out this investigation.

Deventer, September 1916.

Chemistry. — “Some Particular Cases of Current potential Lines” I.

By Dr. A. H. W. ATEN. (Communicated by Prof. F. A. HOLLERMAN).

(Communicated in the Meeting of June 24, 1916.)

1. *Introduction.* When a metal is immersed in a solution that contains the ions of this metal, there arises between the metal and the solution a potential difference, which when equilibrium has set in, is given by the formula

$$E = V_{met} - V_{sol} = \epsilon + \frac{0.058}{n} \log c. \quad (1)$$

for a temperature of 18°, in which formula c is the concentration, n the valency of the ion, and ϵ the value that the potential difference has when the ion concentration is 1.

If the metal is made cathode, the potential difference changes, and the change is the greater as the current density is greater. The line indicating the potential difference at the cathode (or anode) as function of the current density is the current potential line or more strictly speaking the current density potential line. The course of this line has been theoretically examined for some cases. For a theoretical treatment it is required in the first place that also for the electrolysis permanent equilibrium between the metal and the solution is assumed to exist, so that the above given equation is always valid.

The change of E when the current circulates is then the consequence of a change of c , or ϵ , or of both. As ϵ is a constant for a given metal and solvent and at constant temperature and pressure, ϵ can only change when the metal that deposits electrolytically, has other properties than the metal of the cathode. This is e.g. the case when the metal separates in another modification which is not in equilibrium with the first form of the metal, or when the inner composition of the metal is another.¹⁾

In the following considerations we shall leave out of account this possibility, hence we shall assume that ϵ is constant, and examine in what way c depends on the current density, which then at the same time enables us to know the dependence of E on the current density.

The simplest case is here that the dissolved electrolyte is entirely

¹⁾ SMITS and ATEN, These Proc. XVI, p. 699; XVII, p. 37 and 680; XVIII, p. 1485.

ionized into simple, anhydrous ions. NERNST¹⁾ and his pupils have derived an equation of the current potential line for this in the following way.

On deposition of a metal the solution gets poorer in metal ions in the neighbourhood of the cathode; the concentration of the metal ions at the cathode would very soon have become 0, and then the deposition of metal would stop, when not continually metal ions were added to the cathode. This supply takes place in two ways. First in this way that metal ions migrate with the current to the cathode, secondly in this way that the ions go to the cathode by diffusion.

The migration of the metal ions with the current can be practically excluded by addition of an excess of a second electrolyte. In this case the transmission of the current takes chiefly place through the ions of the added electrolyte, and only the diffusion of the ion that is discharged, is to be taken into account. If the added electrolyte is chosen so that it has the same anion as the original one, the diffusion coefficient of the metal ion is proportional with its mobility, viz. for a binary electrolyte at 18° $0,0224 u$, in which u is the electrolytic mobility, expressed in rec. ohms.

If the solution is strongly stirred, it may be assumed that the liquid has the same concentration throughout, except in a very thin layer on the electrode, which is not set in motion by the stirring. In this layer, the thickness of which is dependent on the velocity of the stirring, the movement of the ion only takes place by diffusion. When we electrolyze with a constant current density, and all circumstances remain the same for the rest, a stationary state will arise in this diffusion layer. An equal number of ions then pass per second through every section of the diffusion layer, and all the ions arriving per second at the cathode, are discharged per second there. This latter condition gives a connection between the current density and the diffusion velocity.

If the concentration of the ions in the solution outside the diffusion layer is C and at the cathode c , and the thickness of the diffusion layer δ , the gradient of concentration in the diffusion layer is $\frac{C-c}{\delta}$, and the quantity of ions passing per second through a section of 1 cm². is $\frac{D}{86400} \frac{C-c}{\delta}$, if D is the coefficient of diffusion per day.

¹⁾ Cf. NERNST, Ber. **30** (1897) 1553. SALOMON, Z. phys. Chemie **24** (1897) 54, **25** (1898) 365, COTTRELL *ibid* **42** (1903) 385, GRASSI, *ibid* **44** (1903) 460 BRUNNER, *ibid* **47** (1904) 56, NERNST and MERRIAM, *ibid*. **53** (1905) 235.

The same quantity of ions must be discharged per second at 1 cm². of area of the cathode. The charge of this quantity of ions is therefore equal to the current density d

$$d = \frac{96500}{86400} D \frac{C-c}{\delta},$$

$$d = 1.117 D \frac{C-c}{\delta} \dots \dots \dots (2)$$

and by combination of (1) and (2) we get :

$$E = \epsilon + \frac{0.058}{n} \log \left(C - \frac{d\delta}{1.117 D} \right) \dots \dots \dots (3)$$

A similar equation holds for the anodic polarisation.

Here $d = 1.117 D \frac{c_a - C}{\delta}$, where c_a represents the concentration of the metal ions at the anode.

The anodic and the cathodic polarisation may also be represented by the same equation, when the current density at one of the electrodes, e.g. the cathode, is taken negative.

Then we get :

$$d = 1.117 D \frac{c - C}{\delta} \dots \dots \dots (4)$$

and

$$E = \epsilon + \frac{0.058}{n} \log \left(C + \frac{d\delta}{1.117 D} \right) \dots \dots \dots (5)$$

In figure 1 the general course of this line is represented by a . Positive current densities here refer to the anode, negative ones to the cathode. It is seen from the course of the line that with decreasing values of the potential the current density at the cathode approaches to a limiting value. This current density, which cannot be exceeded, bears the name of limiting current. The value of this current density follows from (4).

The smallest value that c can have, is 0 ; hence the greatest value for the cathodic current density :

$$d_{K \text{ limit}} = - 1.117 D \frac{C}{\delta} \dots \dots \dots (6)$$

This cathodic limiting current is, therefore, proportional to the concentration of the ions in the electrolyte, and to the diffusion coefficient, and in inverse ratio to the thickness of the diffusion layer.

There does not exist a limiting current in the same sense at the anode. When, however, anode and cathode have the same area, the current density is the same for them. Hence :

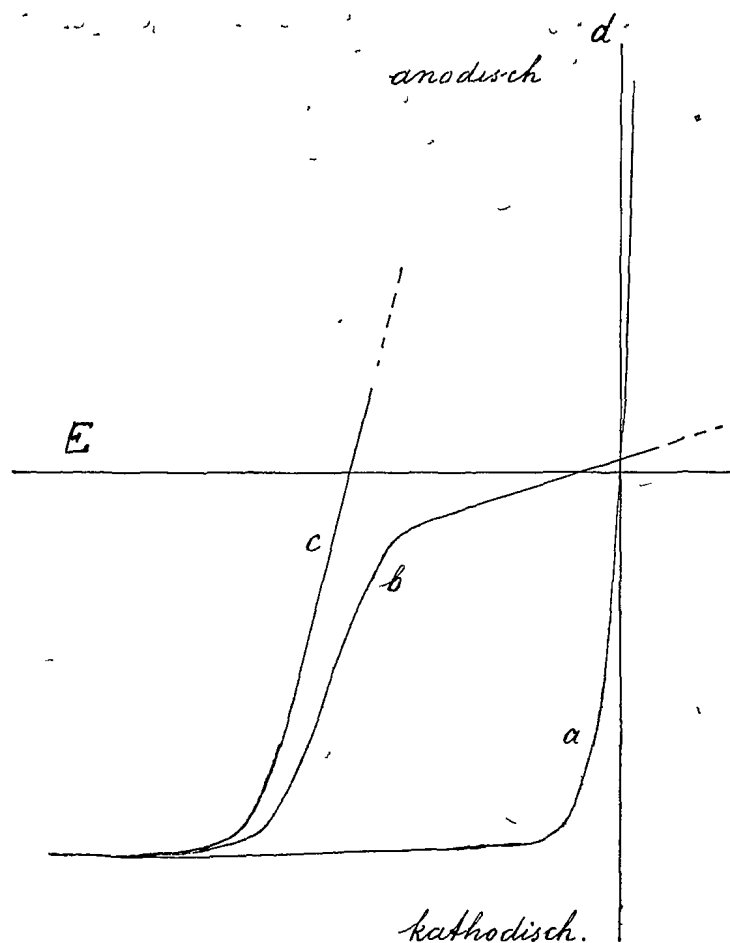

Fig. 1.

anodisch = anodic ; kathodisch = cathodic

$$d_a = 1.117 D \frac{C}{\delta} \dots \dots \dots (7)$$

for the cathodic limiting current, and :

$$E_a = \epsilon + \frac{0.058}{n} {}^{10}\log 2C.$$

$$E_a = \epsilon + \frac{0.058}{n} {}^{10}\log C + \frac{0.058}{n} {}^{10}\log 2 \dots \dots \dots (8)$$

From which follows that the polarisation voltage at the anode is equal to $\frac{0.017}{n}$, when the current density is equal to the cathodic limiting current. This value is, therefore, a constant, which is independent of the nature of the electrolyte, of the concentration, and

of the velocity of stirring, when the stirring is equally vigorous at the cathode and at the anode.

It is, indeed, also possible to speak of an anodic limiting current, in so far as at a certain current density the concentration of the ions at the anode can become greater than that in a saturate solution of the electrolyte. In this case the electrolyte will crystallize out on the anode, on account of which the current will be broken, or at least weakened.

As $c_a = 2C$ for the cathodic limiting current, this crystallizing cannot take place when the original concentration of the ions in the solution is half that of the saturate solution.

For small current densities :

$$\frac{\Delta E}{\Delta d} = \frac{0.025}{n} \frac{d}{1.117 DC} \dots \dots \dots (9)$$

So that for small current densities the current density for a given polarisation tension ΔE is proportional to the concentration.

On comparison of the course of this theoretical line with the experimentally determined lines it appears that in some cases (nitrates and chlorates of different heavy metals) the course of the two lines agrees. In a great many cases the course of the real lines is, however, different, namely so, that in many cases they are much flatter, especially in the beginning, about as the line *b* in figure 1. This is the case for solutions in which complex ions occur, also in case of hydrogen generation, and for metals that can show passivity. In the two last cases the divergent course does not lie in the value of c , but of ϵ , so that they are left out of consideration. For the complex ion the current opinion is ¹⁾ that the deviations are caused by a slow formation of elementary ions from complex or hydrated ions.

This view rests chiefly on observations by HABER and RUSS ²⁾ on reduction of organic compounds, and of LE BLANC and SCHICK ³⁾ on the results of alternate current electrolysis in solutions of complex ions.

EUCKEN ⁴⁾, however, has shown that though the complex ions rapidly split up into simple ones, the current potential line belongs to the type *b* and not to the type *a* of figure 1.

The derivation which EUCKEN gives, is pretty intricate, as he bases it on the supposition that the simple ions are formed with a

¹⁾ Cf. e.g. FOERSTER, Elektrochemie wassriger Lösungen. Leipzig 1915, p. 252 et seq.

²⁾ Z. phys. Chemie 47 (1904) 257.

³⁾ Z. phys. Chemie 46 (1903) 213, Z Elektrochemie 9 (1903) 636

⁴⁾ Z phys. Chemie 64 (1908) 562.

limited velocity, draws up a general equation for this, and derives from this the equation in case of rapid establishment of the equilibrium by assuming the velocity constant to be infinitely great.

2. *Complex Ions.*

In the following way we arrive, however, easily at the equation of the current potential line in a solution of complex ions.

Let us take as an example a solution of a silver salt in ammonia, in which the complex ions $\text{Ag}^+(\text{NH}_3)_2$ occur, which are in equilibrium with free ions Ag^+ and molecules NH_3 .

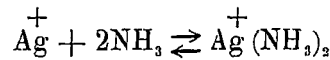

then, as

$$K \cdot C_{\text{Ag}^+} \cdot C_{\text{NH}_3}^2 = C_{\text{Ag}^+(\text{NH}_3)_2}^+$$

and

$$E = \varepsilon + 0.058 \cdot {}^{10}\log C_{\text{Ag}^+}$$

$$E = \varepsilon - 0.058 \cdot {}^{10}\log K + 0.058 \cdot {}^{10}\log C_{\text{Ag}^+(\text{NH}_3)_2}^+ - 0.116 \cdot {}^{10}\log C_{\text{NH}_3}$$

When in general an n -valent ion A combines with p -molecules or ions B , then

$$E = \varepsilon - \frac{0.058}{n} \cdot {}^{10}\log K + \frac{0.058}{n} \cdot {}^{10}\log C_{AB_p} - \frac{0.058}{n} \cdot p \cdot {}^{10}\log C_B \quad (10)$$

By electrolysis the ions AB_p are now discharged on the cathode, the metal A is deposited on the cathode, B remaining in solution. At the cathode there arises, therefore, a deficit of the ions AB_p , and an excess of B . The latter moves away from the cathode through diffusion, the former towards the cathode.

When a stationary state has set in, the following equation will hold for the ions AB_p :

$$d = 1.117 D_1 \frac{eK_1 - C_1}{d}, \dots \dots \dots (11)$$

This equation holds for the anodic polarisation, when the current density at the anode is taken positive. The index 1 refers to complex ions.

With regard to the particles B we may state that at the cathode an equal number must disappear through diffusion as are liberated through discharge of the complex ions, hence p times the number of complex ions diffusing towards the cathode.

This last quantity is

$$\frac{pD_1}{86400} \frac{C_1 - eK_1}{d}, \dots \dots \dots (12)$$

whereas there vanish by diffusion :

$$\frac{D_2}{86400} \cdot \frac{c_{K_2} - C_2}{d}, \dots \dots \dots (13)$$

when the index 2 refers to the particles of the complex former.

From this follows :

$$p D_1 (C_1 - c_{K_1}) = D_2 (c_{K_2} - C_2) \dots \dots \dots (14)$$

This combined with (11), yields :

$$c_{K_2} = C_2 - \frac{pd\sigma}{1.117D_2} \dots \dots \dots (15)$$

On substitution of these values in (10) the equation of the current potential line becomes :

$$E = \varepsilon - \frac{0.058}{n} {}^{10}\log K + \frac{0.058}{n} {}^{10}\log \left(C_1 + \frac{d\sigma}{1.117D_1} \right) \left\{ \begin{array}{l} \\ - 0.058 \frac{p}{n} {}^{10}\log \left(C_2 - \frac{pd\sigma}{1.117D_2} \right) \end{array} \right. \dots \dots \dots (16)$$

The course of this line depends in the same way on the concentration of the complex ions, as for simple salts on the concentration of the elementary ions. The term $-\frac{0.058 {}^{10}\log K}{n}$ causes the potentials to be more negative than for simple salts, K always having a very great value for the complex ions considered here. The above considerations do not apply to ions of slight complexity, as for this we should not only have to take the diffusion of the complex ions into account, but also the diffusion of the elementary ions present.

Accordingly the value of K has only influence on the situation of the line, not on the form.

The last term of (16) has the greatest influence on the form of the line. It causes the line to run very flat in the beginning. The slope of the current potential line for small current densities is given by :

$$\left(\frac{\Delta E}{\Delta d} \right)_{d=0} = \frac{0.025}{n} \frac{\sigma}{1.117D_1 C_1} + \frac{0.025}{n} \frac{p^2 \sigma}{1.117D_2 C_2}, \dots \dots \dots (17)$$

Hence the value of $\frac{\Delta E}{\Delta d}$ will be much greater than for simple salts, especially for small value of C_2 . The factor $0.025 \frac{p^2}{n}$ causes the line to run the flatter as the number of molecules bound by the ion, is greater. In general the line will, therefore, run flatter for bivalent ions than for univalent ones, because $\frac{p}{n}$, hence the number of mole-

cules bound by an equivalent of an ion, is in many cases constant for the same complex former.

If C_2 , the concentration of the complex forming molecules, is great, the term $\frac{0.025 p^2}{n} \cdot \frac{\delta}{1.117 D_2 C_2}$ has less influence, and therefore the current tension line has a more normal course.

Because the complexity constant in equation (16) only occurs in the term $0.058^{10} \log K$, it seems that the complexity of the ion has no influence on the form of the line. This is only true for equal values of C_2 . For ions of different complexity C_2 will in general be different, and that greatest for the least complex ions. In consequence of this a current potential line of a less complex ion has a more normal course than that of an ion of greater complexity.

The expression for the cathodic limiting current is the same as in the case of simple ions, namely :

$$d_{limit} = - \frac{1.117 D_1 C_1}{\delta} \dots \dots \dots (17a)$$

An anodic limiting current exists here no more than in the case of simple salts. According to equation (16) the greatest current density possible at the anode would be that for which :

$$C_2 = \frac{pd\delta}{1.117 D_2},$$

as for a greater value of d the last term of (16) would become the logarithm of a negative value. For this current density equation (16), however, no longer holds. This case will be more fully discussed in a later chapter.

In Fig. 1 the line b is drawn for an electrolyte as $\text{Ag}(\text{NH}_3)_2^+$, which is $0.1 n$ for the complex ions, and $0.001 n$ for NH_3 , c holding for the same electrolyte, but with $0.1 n \text{ NH}_3$. This last line agrees pretty well in form with that for simple ions, a .

3. *Hydrated Ions.* The above derivations are, however, not quite complete, in so far as the hydration of the ions is not taken into account.

That the ions in aqueous solutions are hydrated, may be assumed to be an established fact. Whether the water is chemically bound, or is carried along to join the movement of the ions in another way is an open question, which, however, is immaterial for this purpose. Nor is the number of molecules, carried along by the different ions, accurately known.¹⁾

¹⁾ For a summary of the present state of the problem of hydration see NILRATAN DHAR. Z. f. Elektrochemie 20 (1914) 57.

Further it is not known whether complex ions as $\text{Ag}^+(\text{NH}_3)_2$ are hydrated too, or whether the molecules NH_3 have replaced the water molecules of the hydrated ion.

That the water carried along by the ions must be of influence on the course of the current tension line easily appears in the following way: The hydrated metal ions which are discharged at the cathode, leave their water behind. Hence there takes place an accumulation of water at the cathode. The solution at the cathode will, therefore, be more dilute than in the case of anhydrous ions, as in the latter case only the ions disappear from the solution, but besides water is still added here. Consequently for a given current density a greater polarisation voltage will belong to hydrated ions than to anhydrous ions.

The way in which the water liberated at the cathode disappears, is different from the way in which the ammonia of the complex ion $\text{Ag}^+(\text{NH}_3)_2$ moves away from the cathode. The released water can namely not move away by diffusion, because for the water there exists practically no difference of concentration. There will, however, take place a movement of the water from the cathode, because always a new quantity of water is liberated at the cathode, and this supplants the already present water. Hence the consequence will be that the liquid as a whole gets a movement away from the cathode.

On the ground of these considerations we arrive at an equation of the current potential line. When a gramme equivalent of the metal ion carries along with it a molecules of water, then when a current density d prevails, $\frac{d}{96500}$ gramme equivalents will be discharged per second; hence $\frac{d}{96500} a$ mol. of water will be liberated, occupying a volume of $18a \frac{d}{96500} \text{ cm}^3$.

The liquid moves, therefore, with a velocity of $18a \frac{d}{96500} \text{ cm.}$ per sec. from the cathode. Let a concentration difference $\frac{dc}{dx}$ exist in the diffusion layer at a distance x from the cathode, when a stationary state has set in. Then the quantity of ions, diffusing per second to the cathode is $\frac{D}{86400} \frac{dc}{dx}$.

As the liquid moves away from the cathode with a velocity

$18a \frac{d}{96500}$ cm./sec., the quantity of ions that reaches the cathode per second must be diminished by $18a \frac{d}{96500}$, so that the quantity of ions arriving at the cathode in a second, is given by:

$$\frac{D}{86400} \frac{dc}{dx} - 18a \frac{d}{96500} c. \dots \dots \dots (18)$$

which expression must, therefore, be equal to $\frac{d}{96500}$.

From this follows:

$$d \cdot (1 + 18ac) = 1.117 D \frac{dc}{dx} \dots \dots \dots (19)$$

or

$$\frac{d}{1.117 D} dx = \frac{dc}{1 + 18ac}$$

By integration:

$$\frac{d}{1.117 D} x = \frac{1}{18a} \ln(1 + 18ac) + K \dots \dots \dots (20)$$

in which for $x = 0$ $c = c$, and for $x = \delta$ $c = C$, hence

$$\frac{d}{1.117 D} \delta = \frac{1}{18a} \ln \left(\frac{1 + 18aC}{1 + 18ac} \right)$$

If the cathodic current density is taken negative, the anodic positive, the following equation holds:

$$\frac{d\delta}{1.117 D} = \frac{1}{18a} \ln \left(\frac{1 + 18ac}{1 + 18aC} \right) \dots \dots \dots (21)$$

both for cathodic and for anodic polarisation.

By combining (21) with the equation for the potential difference

$$E = \varepsilon + \frac{0.058}{n} \log c$$

we can indicate E as function of d .

The cathodic limiting current is here:

$$d_{K \text{ limit}} = - 1.117 \frac{D}{18a\delta} \ln(1 + 18aC) \dots \dots \dots (22)$$

while

$$\left(\frac{\Delta E}{\Delta d} \right)_{d=0} = \frac{0.025 \delta (1 + 18aC)}{1.117 DCn} \dots \dots \dots (23)$$

It appears from these equations as was indeed to be expected, that the influence of hydration on the course of the current potential line is slight. When the solution contains 1 gram-ion per liter, when

$c = 0.001$ and a is 6, the limiting current is $0.95 \times$ the limiting current for the same anhydrous ions, and $\left(\frac{\Delta E}{\Delta d}\right)_{d=0}$ is $1.1 \times$ this value without hydration.

Though the determination of the current potential line supplies us with a means for the determination of the hydration of the ions, this means will only be serviceable when we succeed in carrying out the determination of the current potential line very accurately. Theoretically this method may be put on a line with the method followed by BUCHBOCK¹⁾, WASHBURN²⁾ and others, where the degree of hydration is derived from an indirect determination of the quantity of water liberated at the cathode. According to equation (21) we find here the hydration of the cation alone, whereas BUCHBOCK and WASHBURN's method furnishes the difference of the products of hydration and mobility of cation and anion.

When we polarize anodically with a current density equal to the cathodic limiting current, we get:

$$l(1 + 18 ac_a) = 2l(1 + 18 aC) \dots \dots (24)$$

Hence we have

$$c_a = 2.1 C$$

for the value of hydration and concentration assumed above, whereas we have $c_a = 2C$ without hydration.

Hence the influence of the hydration appears to be slight also at the anode.

Some special cases present themselves with the anodic polarisation when the metal ion can form a sparingly soluble compound with one of the present anions as for solutions of the most complex salts, for electrolysis of solutions of halogenides with a silver anode etc. In some cases it is desirable to prevent the formation of the sparingly soluble solution, as in the electrolysis of solutions of complex cyanides, in other cases it is desired that the compound is deposited on the anode, e.g. in the electrolytical determination of the halogens, and sometimes too it is desirable that the compound separates in the liquid, namely in the method of LÜCKOW³⁾ for the electrolytical formation of metal compounds.

In virtue of the above considerations it is now possible to give the conditions on which the process will take place in one way or another.

¹⁾ Z. f. physik. Chemie 55 (1906) 563.

²⁾ Jahr. d. Radioaktivität 5 (1908) 493, 6 (1909) 69.

³⁾ Z. f. Elektrochemie 3 (1897) 482.

4. Anodic formation of silverhaloids.

Let us suppose the case that a silver anode is placed in a solution of sodium chloride with an excess of sodium nitrate, so that only the diffusion of the chlorine ion is to be taken into account, not its migration. On anodic polarisation the chlorine ions will be discharged at the silver, and then give AgCl. When, however, the current density is so great that fewer chlorine ions diffuse towards the anode than corresponds to this current density, also silver ions will go into solution. Strictly speaking the latter always takes place, because silver chloride is not absolutely insoluble, and therefore not all the AgCl formed will remain on the anode, but will go into solution for a small part.

In the following way we now arrive at an equation of the current potential line for anodic polarisation of silver in NaCl.

For a given current density there prevails at the anode a certain chlorine ion-concentration c_{1a} , and a certain silver ion-concentration c_{2a} . The product of these values is equal to the solubility product of silver chloride

$$c_{1a} c_{2a} = L.$$

Not only at the anode, but also in the diffusion layer and in the whole liquid the solution is saturate with AgCl, hence

$$C_1 C_2 = L$$

holds everywhere.

In the diffusion layer c_1 and c_2 have values which are a function of the distance x to the anode, in the rest of the liquid they have a constant value, which we denote by C_1 and C_2 .

Now per unit of time a certain quantity of chlorine ions arrive through diffusion at the anode, there disappear per unit of time a certain quantity of silver ions; the sum of these two quantities, multiplied by the charge per gramme ion, gives the current density.

Here the quantity of ions passing through a section of the diffusion layer, is not the same for every section as it is in the preceding cases, for here also silver chloride must deposit, which causes chlorine ions and silver ions to disappear in equivalent quantities.

If we now consider a volume of the diffusion layer between a section at a distance x from the anode, and another at a distance $x + dx$, the quantity of silver ions or chlorine ions passing through the first section will in general not be equal to that passing through the second.

Through the section x a quantity of chlorine ions $-\frac{D_1 dc_1}{dx}$ will

diffuse, through the section $x + dx$ a quantity $- D_1 \left(\frac{dc_1}{dx} + \frac{d^2c_1}{dx^2} dx \right)$ in the direction of increasing x . The quantity of chlorine ions, which is deposited as AgCl is, therefore, the difference between the two quantities $D_1 \frac{d^2c_1}{dx^2} dx$.

In the same way a quantity of silver ions is deposited equal to $D_2 \frac{d^2c_2}{dx^2} dx$; these two are equal, hence:

$$D_1 \frac{d^2c_1}{dx^2} = D_2 \frac{d^2c_2}{dx^2}, \quad \dots \dots \dots (25)$$

$$\frac{d^2c_2}{dx^2} = \frac{D_1}{D_2} \frac{d^2c_1}{dx^2}.$$

$$\frac{dc_2}{dx} = \frac{D_1}{D_2} \frac{dc_1}{dx} + A \quad \dots \dots \dots (26)$$

$$c_2 = \frac{D_1}{D_2} c_1 + Ax + B, \text{ in which } c_2 = \frac{L}{c_1} \quad \dots \dots \dots (27)$$

The values of A and B are found in the following way:

For $x = 0$ $c_1 = c_{1a}$ and $c_2 = c_{2a}$, the concentration of \overline{Cl} , resp. \overline{Ag} at the anode,

$$\text{hence} \quad c_{2a} = \frac{D_1}{D_2} c_{1a} + B, \quad B = c_{2a} - \frac{D_1}{D_2} c_{1a},$$

for $x = \delta$ $c_1 = C_1$ and $c_2 = C_2$, the concentration of \overline{Cl} , resp. \overline{Ag} in the solution.

$$C_2 = \frac{D_1}{D_2} C_1 + A\delta + c_{2a} - \frac{D_1}{D_2} c_{1a},$$

$$A = \frac{C_2 - \frac{D_1}{D_2} C_1 - \left(c_{2a} - \frac{D_1}{D_2} c_{1a} \right)}{\delta} \quad \dots \dots \dots (28)$$

If we now call the current density maintained by the diffusion of the chlorine ions d_1 and that maintained by the diffusion of the silver ions d_2 , then:

$$d_1 = 1.117 D_1 \left(\frac{dc_1}{dx} \right)_{x=0} \quad \dots \dots \dots (29)$$

$$d_2 = -1.117 D_2 \left(\frac{dc_2}{dx} \right)_{x=0} \quad \dots \dots \dots (30)$$

and the total current density

$$d = d_1 + d_2 = 1.117 D_1 \left(\frac{dc_1}{dx} \right)_{x=0} - 1.117 D_2 \left(\frac{dc_2}{dx} \right)_{x=0} \quad (31)$$

As further $c_1 c_2 = L$:

$$c_1 \frac{dc_2}{dx} + c_2 \frac{dc_1}{dx} = 0$$

This equation combined with (26) yields:

$$\left(\frac{dc_1}{dx} \right)_{x=0} = - \frac{Ac_{1a}}{\frac{D_1}{D_2} c_{1a} + c_{2a}} \quad (32)$$

$$\left(\frac{dc_2}{dx} \right)_{x=0} = \frac{Ac_{2a}}{\frac{D_1}{D_2} c_{1a} + c_{2a}} \quad (33)$$

Now d_1 becomes:

$$d_1 = -1.117 D_1 \frac{Ac_{1a}}{\frac{D_1}{D_2} c_{1a} + c_{2a}} \quad (34)$$

and d_2 becomes:

$$d_2 = -1.117 D_2 \frac{Ac_{2a}}{\frac{D_1}{D_2} c_{1a} + c_{2a}} \quad (35)$$

If in these equations the value of A from (28) is introduced, we get:

$$d_1 = -1.117 D_1 \frac{c_{1a} \left[C_2 - \frac{D_1}{D_2} C_1 - \left(c_{2a} - \frac{D_1}{D_2} c_{1a} \right) \right]}{\frac{D_1}{D_2} c_{1a} + c_{2a}}$$

or

$$d_1 = \frac{1.117 D_1 c_{1a} D_2 (c_{2a} - C_2) + D_1 (C_1 - c_{1a})}{\delta D_1 c_{1a} + D_2 c_{2a}} \quad (36)$$

and

$$d_2 = \frac{1.117 D_2 c_{2a} D_2 (c_{2a} - C_2) + D_1 (C_1 - c_{1a})}{\delta D_1 c_{1a} + D_2 c_{2a}} \quad (37)$$

in which $c_{1a} c_{2a} = C_1 C_2 = L$.

The total current density is now given by:

$$d = 1.117 \frac{D_2 (c_{2a} - C_2) + D_1 (C_1 - c_{1a})}{\delta} \quad (38)$$

This equation combined with:

$$E = \varepsilon + 0.058 \log c_{2a}$$

yields the course of the current tension line.

Figure 2 gives a number of current potential lines for a silver anode in solutions for a chloride from $C_1=10^{-2}$ to $C_1=10^{-7}$.

On the axis of abscissae the $^{10}\log C \text{ Ag}^+$ has been drawn which is proportional to the potential, on the ordinate axis the current density d . In this $D_1 = D_2$ has been put and $L = 10^{-10}$.

With a comparatively great chlorine ion concentration, 10^{-2} , the

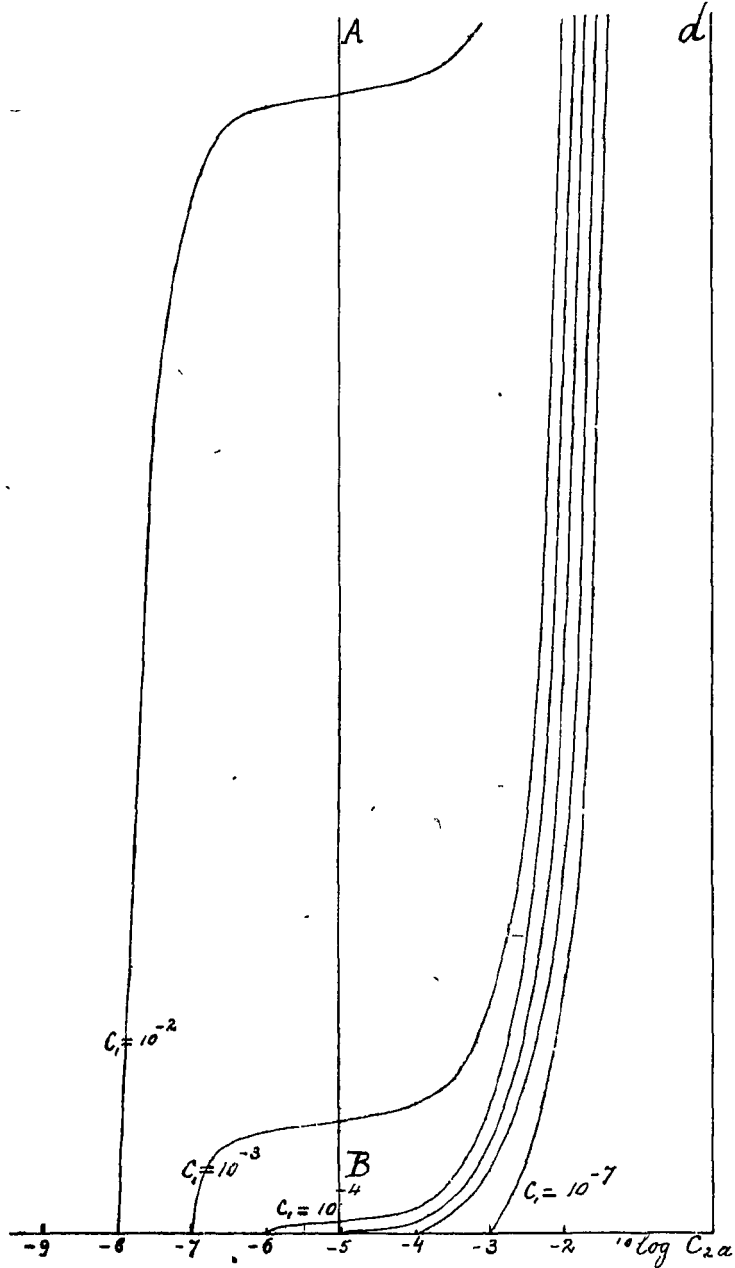

Fig. 2.

potential of the silver is least positive for $d = 0$; with increasing intensity of the current the metal becomes at first only little more positive, till at a given current density the line suddenly bends, so that the potential becomes much more positive, and eventually on further increase of the current density it rises again more slowly. The same phenomenon is presented by the line for $C_1 = 10^{-3}$, but for smaller current density and also the line for $C_1 = 10^{-4}$ faintly shows this course. With smaller chlorine ion concentration the course of the current potential line approaches the normal course more. If the current potential line lies on the left side of the vertical line AB , for which $C_{2a} = 10^{-5} = \sqrt{L}$, the current is chiefly used for deposition of $AgCl$ on the anode, the part lying on the righthand side of the line AB denotes current densities, at which the silver chloride is deposited in the liquid.

This appears in the following way:

Equations (36) and (37) give the current density for deposition of $AgCl$ on the anode and in the liquid.

The proportion
$$\frac{\text{AgCl on the anode}}{\text{AgCl in the liquid}} = \frac{d_1}{d_2} = \frac{D_1 c_{1a}}{D_2 c_{2a}}$$

If we call β the fraction of the total current density used for silver chloride formation on the anode, then

$$d_1 = d\beta \quad \text{en} \quad d_2 = d(1 - \beta) \quad \dots \dots \dots (39)$$

and

$$\frac{\beta}{1 - \beta} = \frac{D_1 c_{1a}}{D_2 c_{2a}}, \text{ or, as } c_{1a} c_{2a} = L.$$

$$c_{2a} = \sqrt{\frac{LD_1(1 - \beta)}{D_2\beta}} \dots \dots \dots (40)$$

and

$$c_{1a} = \sqrt{\frac{LD_2\beta}{D_1(1 - \beta)}} \dots \dots \dots (41)$$

By substitution of these values of c_{1a} and c_{2a} in (38), we get

$$d = \frac{1.117}{\delta} \left[D_1 C_1 - D_2 C_2 + \sqrt{LD_1 D_2 \frac{1 - \beta}{\beta}} - \sqrt{LD_1 D_2 \frac{\beta}{1 - \beta}} \right] \dots (42)$$

where $C_1 C_2 = L$.

In figure 3 β has been drawn as function of the current density. From this appears that for small current densities β is almost constant. Here practically all the $AgCl$ is deposited on the anode. If the current density is increased, there comes a value of the current density where β decreases rapidly, and for still greater current

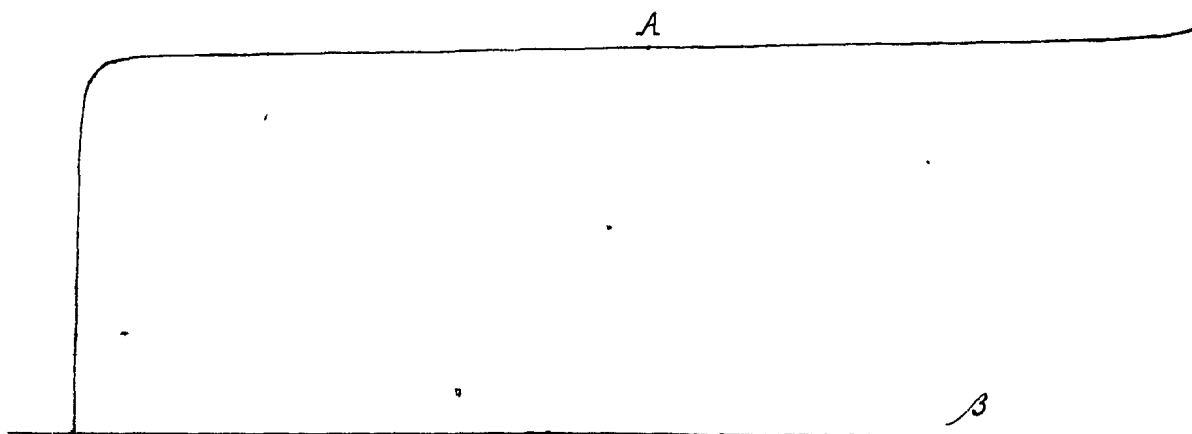

Fig. 3.

density β becomes almost 0, i. e. practically all the silver chloride is deposited in the liquid.

The point of inflection A in the line gives the limit between current densities, at which the AgCl is mostly deposited on the anode, and those at which the AgCl for the greater part deposits in the liquid. The density of the current in A may be called the *critical current density*, the value of β is here $1/2$. Hence we find from (42) for the critical current density:

$$d_{K_c} = \frac{1.117}{\delta} [D_1 C_1 - D_2 C_2] \quad (43)$$

If this equation is written in the form:

$$d_{K_c} = \frac{1.117}{\delta} \left[D_1 C_1 - D_2 \frac{L}{C} \right] \quad (44)$$

we may write, when C_1 is great compared with \sqrt{L} :

$$d_{K_c} = \frac{1.117}{\delta} D_1 C_1$$

In this case the critical current density is therefore proportional to the concentration of the chlorine ions, and it is given by the same equation as the cathodic limiting current for simple salts.

For great values of C_1 the critical current density is therefore, independent of the value of the solubility product, i. e. the value is the same for all halogens, as D_1 is here about equal.

It is different when C_1 has a small value, one that is comparable with \sqrt{L} .

The critical current density is $= 0$, when $D_1 C_1 = D_2 \frac{L}{C_1}$ or, D_1 and D_2 differing little, when $C_1 = \sqrt{L}$. For silver chloride, for which $L = 10^{-10}$, the critical density will therefore be $= 0$ for $C_1 = 10^{-5}$. Already at the smallest possible current density more AgCl will here be deposited in the liquid than on the anode. If on the other hand we work with an iodide, practically all the silver iodide will be deposited on the anode for $C_1 = 10^{-5}$ as $L_{AgI} = 10^{-16}$ and the critical current density is not $= 0$ until $C_1 = 10^{-8}$.

By the aid of the above considerations it is now possible to indicate in what way the electro-analytic determination of the halogens can take place most rationally, as will be set forth in the following paper.

Chemical Laboratory of the University.

Amsterdam, June 1916.

Mathematics. — “*Skew Frequency Curves.*” By M. J. VAN UVEN.
(Communicated by Prof. J. C. KAPTEYN).

(Communicated in the meeting of October 28, 1916).

The skewness of a frequency-curve appertaining to some observed quantity x may be explained, as Prof. J. C. KAPTEYN¹⁾ has shown, without dropping the normal Gaussian law of error, namely by supposing that, instead of the observed quantity x , a certain function of x : $Z = F(x)$, is spread according to the normal law.

Denoting the mean value of Z by M and the modulus of precision by h , the quantity

$$z = h(Z - M) = h\{F(x) - M\} = f(x)$$

will be distributed round the mean value zero with the modulus of precision unity, so that the probability that z is found between z_1 and z_2 is represented by

$$W_{z_1}^{z_2} = \frac{1}{\sqrt{\pi}} \int_{z_1}^{z_2} e^{-z^2} dz.$$

¹⁾ J. C. KAPTEYN: *Skew Frequency Curves in Biology and Statistics*; Groningen, 1903, Noordhoff.

Prof. J. C. KAPTEYN and the author of this paper¹⁾ have developed a method to derive the so-called "normal function" $z = f(x)$ from the given frequency-distribution, by applying the principle corresponding values of x and z are equally probable.

Then it appears that x , as function of z , must be one-valued.

Two simplifications are besides introduced:

1. In the whole real domain, we suppose

$$f'(x) > 0.$$

hereby we prevent that $\frac{dz}{dx} = f'(x)$ may vanish, and consequently that z can be a many-valued function of x .

2. The lower limit x_0 of the real domain corresponds to $z = -\infty$.

In the following paper we shall expand the thus far developed theory by dropping the two simplifications mentioned.

A. First we drop the latter simplification while retaining the first.

So we suppose that the extreme limits x_0 and x_n correspond to the values z_0 and z_n resp. of z , the extreme limits $-\infty$ and $+\infty$ of z being in their turn conjugate to the values $x_{-\infty}$ and $x_{+\infty}$ of x .

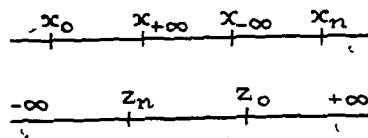

FIG. 1a.

If $x_{+\infty}$ and $x_{-\infty}$ do not coincide, then no part of the real domain is found between these values; so the real domain consists of the partial domains $x_0 \dots x_{+\infty}$ and $x_{-\infty} \dots x_n$. In fact because $f'(x)$ must always be > 0 , to $z_0 < +\infty$

must correspond $x_0 < x_{+\infty}$, and to $z_n > -\infty$ $x_n > x_{-\infty}$.

The segments $x_n \dots +\infty$ and $-\infty \dots x_0$, which do not belong to the real domain, are represented together in the segment between z_n and z_0 of the axis of z , and as x , in passing from x_n to x_0 , continually increases (excepting the fall from $+\infty$ to $-\infty$), also z_n will be less than z_0 .

Now the quantity z must pass through all values from $-\infty$ to $+\infty$; so on the axis of z no segments are found which do not belong to the real domain. Consequently the points z_n and z_0 must coincide.

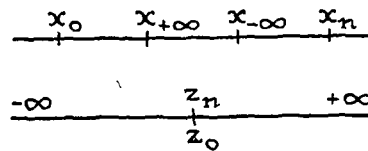

FIG. 1b.

Hence we have this situation (fig. 1b).

If the domain between x_0 and x_n has no gap, there is also coincidence of $x_{+\infty}$ and $x_{-\infty}$.

Such a correspondence is generated by the function

¹⁾ J. C. KAPTEYN and M. J. VAN UYEN: Skew Frequency Curves in Biology and Statistics, 2nd Paper; Groningen, 1916 Hoitsema. Br.

$$z = -\frac{1}{x},$$

where $x_0 \doteq -\infty$, $x_n \doteq +\infty$, $x_{+\infty} = x_{-\infty} = 0$, with $z_0 (\equiv z_n) = 0$.

Another example of a generating function is

$$z = 1 : \log \frac{(x - x_0)(x_n - x)}{(x_n - x_\infty)(x - x_0)}$$

where $z_0 = 0$.

Giving up the simplification $\left. \begin{matrix} z_0 \\ z_n \end{matrix} \right\} = \mp \infty$ may lead to an easier explanation of frequencies in two ways:

For one thing: to choose a value x_∞ conjugate to $z = \mp \infty$ within the frequency-domain ($x_0 < x_\infty < x_n$) may be advantageous if the frequencies become exceedingly small somewhere within the domain. In this case the theoretical value of the ordinate of the frequency-

curve: $y = \frac{1}{\sqrt{\pi}} f'(x) e^{-[f(x)]^2}$ for $x = x_\infty$ is zero (values of $f'(x_\infty)$ of an excessive order of infinity being excluded).

Moreover to join finite values of z to the limits x_0 and x_n of x may help to make high frequencies at the limits admissible, the factor $e^{-[f(x)]^2}$ not being infinitesimal at the limits.

Next we shall examine what happens if we drop the first simplification also and accordingly suppose the function $z = f(x)$ (as function of x) to be many-valued. So to one value of x several values of z may correspond, and infinite values of $\frac{dz}{dx} = f'(x)$ are admitted for finite values of z .

On this supposition there must be partial domains where $f'(x) < 0$, since $\frac{dz}{dx}$, in passing through ∞ , changes its sign.

Thus we seem to come into conflict with the condition that the observed frequency

$$I_{x_1}^{x_2} = \frac{1}{\sqrt{\pi}} \int_{x_1}^{x_2} f'(x) e^{-[f(x)]^2} dx$$

must be positive.

This apparent difficulty is removed by considering that the integral may yet turn out positive, provided that we invert the sense of integrating, so that we proceed along the axis of x in a negative sense in those segments, where $f'(x) < 0$.

We shall now discuss successively two- and three-valued functions.

B. Two-valued functions.

We first consider functions which are two-valued either in the whole real domain or in a part of it.

At the point(s), where the real domain borders on the imaginary one, the two real values of z , which correspond to a single value of x , pass into two imaginary values. So at the limits of the real domain themselves the two values of z coincide. The limits x_0 and x_n of the real domain are the branch-points of the function $z = f(x)$.

Now at the limits of the domain $\frac{dz}{dx} = f'(x) = \infty$; the conjugate value of z may be either finite or infinite. If this value of z is finite, the ordinate

$$y = \frac{1}{\sqrt{\pi}} f'(x) e^{-[f(x)]^2}$$

of the ideal frequency-curve is infinite at that point.

If, on the contrary, the corresponding value of z is infinite, this ordinate is likely to be infinitesimal or zero. Only for exceptional forms of $f(x)$ it might be finite.

If now the frequency-table Y_1, Y_2, \dots, Y_n (Y_k individuals lie between the class-limits x_{k-1} and x_k) begins with a very high value Y_1 , decreasing till the last frequencies are zero, we may explain this by means of a two-valued function, having a branch-point in x_0 with a finite z , and another in x_n with an infinite z .

Let us take as an example

$$z = f(x) = \pm \sqrt{x}.$$

whence

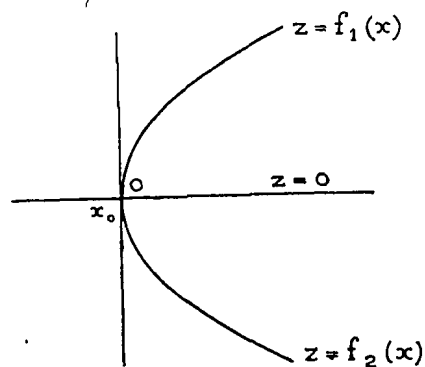

FIG. 2.

$$\frac{dz}{dx} = f'(x) = \pm \frac{1}{2\sqrt{x}}.$$

Here the branch-points are

$$x_0 = 0 \text{ with } z_0 = 0,$$

$$x_n = +\infty \text{ with } z_n = \pm\infty.$$

The two branches of the function are

$$f_1(x) = +\sqrt{x}, \text{ with } f_1'(x) = +\frac{1}{2\sqrt{x}}$$

$$\text{and } y_1 = \frac{+1}{2\sqrt{\pi x}} e^{-x}$$

$$f_2(x) = -\sqrt{x}, \text{ with } f_2'(x) = -\frac{1}{2\sqrt{x}} \text{ and } y_2 = \frac{-1}{2\sqrt{\pi x}} e^{-x}.$$

In the first branch x ranges from 0 to $+\infty$. The contribution to the frequency in the segment pq between $x = x_p$ and $x = x_q (> x_p)$ is then

$$\Delta_1 I = \frac{1}{\sqrt{\pi}} \int_{x_p}^{x_q} f_1'(x) e^{-[f_1(x)]^2} dx = \int_{x_p}^{x_q} \frac{+1}{2\sqrt{\pi x}} e^{-x} dx.$$

In the second branch x comes back from $+\infty$ to 0. So the contribution to the frequency in the same segment pq equals

$$\Delta_2 I = \frac{1}{\sqrt{\pi}} \int_{x_q}^{x_p} f_2'(x) e^{-[f_2(x)]^2} dx = \int_{x_q}^{x_p} \frac{-1}{2\sqrt{\pi x}} e^{-x} dx.$$

The total frequency in the domain in question is therefore found to be:

$$I_p^q = \Delta_1 I + \Delta_2 I = \int_{x_p}^{x_q} \frac{+1}{2\sqrt{\pi x}} e^{-x} dx + \int_{x_q}^{x_p} \frac{-1}{2\sqrt{\pi x}} e^{-x} dx = 2 \int_{x_p}^{x_q} \frac{+1}{2\sqrt{\pi x}} e^{-x} dx$$

The ideal continuous frequency-curve bounds the area, which equals the total frequency. Its equation obviously is

$$y = y_1 - y_2 = 2 y_1 = \frac{1}{\sqrt{\pi x}} e^{-x}.$$

Evidently the axis of y ($x = 0$) and the axis of x ($y = 0$) are asymptotes.

The rough frequency-figure accordingly has a summit at the limit $x = x_0 = 0$ of the domain, and descends towards the other limit ($x = x_n = +\infty$).

A frequency-series, which, starting with a very high value, gradually diminishes further on, can evidently be explained by a discontinuity in the ideal frequency-curve, which in its turn is a consequence of the many-valuedness of the function $z = f(x)$.

For convenience' sake we may suppose, that the two branches of the function $z = f(x)$ consist of equal and opposite values, so that $f_2(x) = -f_1(x)$, these values coinciding at the limits x_0 and x_n .

If the frequency-series Y_1, Y_2, \dots, Y_n gradually descends from the highest value Y_1 , it is natural to join to x_0 a finite value z_0 of z and to x_n an infinite value of z . The two branches being symmetrical (by agreement) we must take $z_0 = 0$.

The curve $z = f(x)$ has then a shape as in the adjoining sketch (fig. 3).

The frequency in a certain segment pq between $x = x_p$ and $x = x_q$ consists of two equal parts:

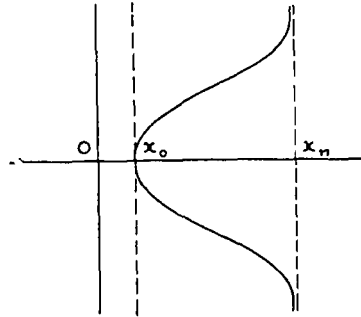

FIG. 3.

$$\Delta_1 I = \frac{1}{\sqrt{\pi}} \int_{x_p}^{x_q} f_1'(x) e^{-[f_1(x)]^2} dx$$

and $\Delta_2 I = \frac{1}{\sqrt{\pi}} \int_{x_q}^{x_p} f_2'(x) e^{-[f_2(x)]^2} dx =$

$$= \frac{1}{\sqrt{\pi}} \int_{x_q}^{x_p} -f_1'(x) e^{-[f_1(x)]^2} dx = \Delta_1 I.$$

In order to construct the branch $f_1(x)$ we join x_0 to $z = 0$, or $I = \frac{1}{2}$, and a point $x = x_k$ to the value z_k which satisfies

$$\Theta(z_k) = \frac{1}{\sqrt{\pi}} \int_{-\infty}^{z_k} e^{-z^2} dz = \frac{1}{2} + \frac{1}{2} I(x_k),$$

where $I(x_k)$ represents the quotient $\frac{Y_1 + Y_2 + \dots + Y_k}{N}$ of the number of individuals between x_0 and x_k (thus smaller than x_k), divided by the total number $N = \sum Y_k$.

In this way we obtain $n-1$ points (x_k, z_k) ($k = 1, \dots, n-1$) of the positive branch of the curve. Evidently the negative branch will be the reflected image of the positive one.

In reality neither of the limiting points x_0 and x_n is exactly determined by the rough frequency-figure. By tracing a continuous line through the $n-1$ points (x_k, z_k) of the positive branch and another through their reflected images, and uniting these curves as smoothly as possible, we may fix pretty sharply the most probable situation of the point of intersection with the axis of x ($x = x_0, z = 0$).

In the same manner the asymptote $x = x_n$ must be determined by estimating. If it seems to lie very far away, x_n may often be put $= \infty$, as i.a. in the case of the above example $z = \pm \sqrt{x}$.

In general the form of the equation will be

$$z = f(x) = \pm \sqrt{g(x)},$$

where $g(x)$ is a one-valued function of x , which in the real domain only vanishes at $x = x_0$ and becomes infinite at $x = x_n$ (c.q. $x_n = \infty$).

If we had applied the original method, founded on the two simplifications, x_0 would have been joined to $z = -\infty$ and x_n to

$z = +\infty$. The first frequency-number Y_1 being large, the value of z now rises in a very short interval $x_0 \dots x_1$ from $-\infty$ to a value slightly below zero, or perhaps above zero.

Although $f'(x_0)$ becomes infinite, yet in the ideal frequency-curve

$$\lim_{x \rightarrow x_0} y = \lim_{x \rightarrow x_0} \frac{1}{\sqrt{x}} f'(x) e^{-[f(x)]^2} = 0$$

unless an improbable form is assumed for $f(x)$. But also, very peculiar forms of $f(x)$ being excluded,

$$\frac{dy}{dx} = \frac{1}{\sqrt{x}} \{f''(x) - 2f(x) \cdot [f'(x)]^2\} e^{-[f(x)]^2}$$

will approach to zero, that is: the ideal frequency-curve will touch the axis of x in $x = x_0$. Then neither y nor $\frac{dy}{dx}$ shows a discontinuity in x_0 .

Since however the area must already assume a considerable value in the first interval, not only the slope but also the ordinate must increase rapidly (fig. 4).

This case is realised for instance with

$$z = \log x$$

So the discontinuity of the rough frequency-curve appears as an accumulation of elementary frequencies which are finite, continuous and descending to zero.

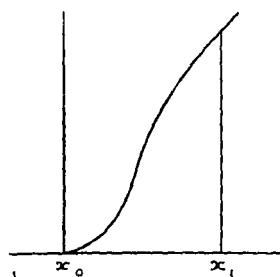

Fig. 4

Whether the original simplified or the extended method is preferable, is difficult to decide a priori. Perhaps it is possible to refine the data in the first interval and to obtain frequency-numbers for portions of the first class-interval. If these numbers, after continued subdivision, at last begin to decrease as we approach x_0 , then the original method (of the continuous frequency-figure) is to be preferred. If on the other hand even by the finest subdivision an increase of the frequencies towards x_0 is found, then it is necessary to admit discontinuity, and the extended method must be applied.

Of the integral-curve

$$I = \int_{x_0}^x y dx,$$

observation furnishes the ordinates

$$I_1 = \frac{Y_1}{N} \quad I_2 = \frac{Y_1 + Y_2}{N}, \dots I_k = \frac{Y_1 + Y_2 + \dots + Y_k}{N}, \dots I_{n-1} = \frac{Y_1 + Y_2 + \dots + Y_{n-1}}{N},$$

the initial ordinate I_0 being zero of course, and the final ordinate I_n being certainly unity.

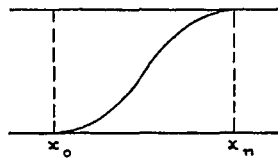

FIG. 5.

In the common case, where the frequencies decrease towards both the extremities, the integral-curve has a course like fig. 5. But if the first frequency I_1 is still great, so that we are inclined to admit a discontinuity in $y = \frac{dI}{dx}$,

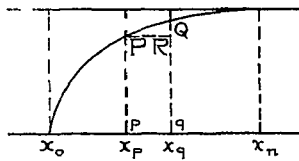

FIG. 6.

the curve $I(x)$ has the aspect of fig. 6.

Now the extended method joins to a single value of x two opposite values of $y = \frac{dI}{dx}$

in this manner we also obtain two branches $I = \Phi_1(x)$ and $I = \Phi_2(x)$ of the integral-curve, satisfying the relation

$$y_2 = \frac{d\Phi_2(x)}{dx} = -y_1 = -\frac{d\Phi_1(x)}{dx}.$$

whence

$$\Phi_1(x) + \Phi_2(x) = \text{constant},$$

and, x_n being assumed conjugate as well with $z = -\infty$ as with $z = +\infty$, the constant is unity.

So we replace the last-given figure by another of the shape of fig. 7, which is symmetrical with regard to the line $I = \frac{1}{2}$.

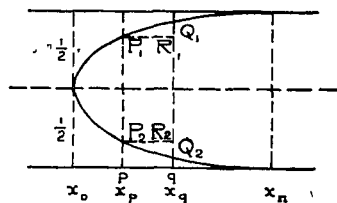

FIG. 7.

The value of I at the point $p(x=x_p)$, which was formerly (fig. 6) represented by the ordinate pP , is now given by the difference

$$pP_1 - pP_2 = P_1P_2 = pP.$$

The increase of I in the interval pq was formerly equal to the rise of the ordinate, viz. $qQ - pP = RQ$. At present it is the sum of the increase $qQ_1 - pP_1 = R_1Q_1$ and the increase $pP_2 - qQ_2 = Q_2R_2$ (fig. 7); this latter corresponds to the second branch, in which the axis of x is assumed to be travelled along in a negative sense.

The area, which was formerly bounded by the curve $I(x)$, the axis of x and the final ordinate-line $x = x_n$, is now found again in the area inclosed between the two branches Φ_1 and Φ_2 and the final ordinate-line $x = x_n$. So it is as if the area of the original figure is so far lifted up as to be symmetrically divided by the line $I = \frac{1}{2}$.

Now we might begin with this latter operation and derive the

two-branched curve $I = \Phi_1(x)$, $I = \Phi_2(x)$ from the curve $I = \Phi(x)$. Then, by fixing the values of z , conjugate to the different values of I , according to the relation

$$\Theta(z) = \frac{1}{\sqrt{\pi}} \int_{-\infty}^z e^{-t^2} dt = I,$$

we obtain the required symmetrical curve $z = f(x)$, which for a single value of x gives two opposite values of z .

Also the reaction-function ¹⁾

$$\eta = \frac{1}{f'(x)}$$

has two opposite values for each value of x . There are two domains (overlapping the same segment of the axis of x), one of positive, the other of negative growth. It is exactly this negative growth which explains the accumulation at the lower limit.

We next consider the case that the frequency-domain ends at both sides with rising frequency-numbers, so that the smaller frequencies lie inside.

Now the two limits x_0 and x_n must correspond to finite values of z , being at the same time branch-points of the function $z = f(x)$ which is assumed two-valued.

Thus the curve $z = f(x)$ must have either the form of fig. 8a, or that of fig. 8b. The former represents a function, which is two-valued in the whole domain, with a single asymptote $x = x_\infty$. The

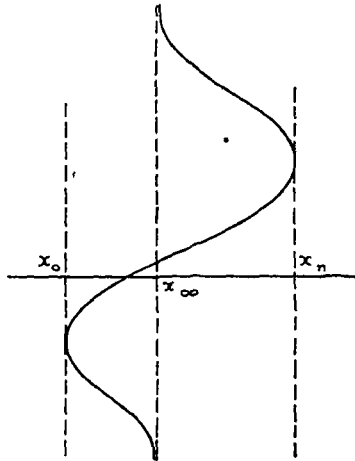

FIG. 8a.

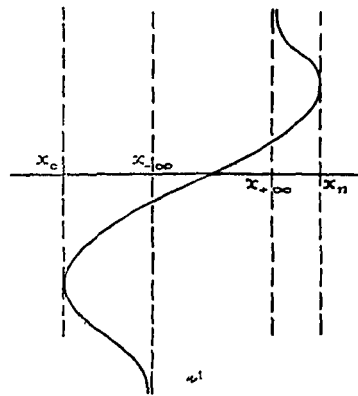

FIG. 8b.

¹⁾ J. C. KAPTEYN and M. J. VAN UVEN: Skew Frequency Curves in Biology and Statistics, 2nd Paper; Groningen, 1916, Hoitsema Br.

latter belongs to a function, which is two-valued in the zones $x_0 \dots x_{-\infty}$ and $x_{+\infty} \dots x_n$, but one-valued in the part $x_{-\infty} \dots x_{+\infty}$; it has two asymptotes, $x = x_{-\infty}$ for $z = -\infty$ and $x = x_{+\infty}$ for $z = +\infty$. It is usually difficult, from a mathematical point of view, to decide between these two forms.

The branches of the function where $f'(x) < 0$ correspond to negative values of the reaction-function, hence with negative growth. It may be desirable, for biological reasons, to suppose such domains of negative growth as small as possible. In this case the second form is to be preferred.

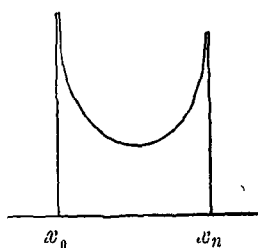

FIG. 9.

The ideal frequency-curve (fig. 9) has now two asymptotes, viz $x = x_0$ and $x = x_n$.

The integral-curve $I = \Phi(x)$ (fig. 10), directly derived from the observations, touches the line $x = x_0$ in $(x = x_0, I = 0)$ and the line $x = x_n$ in $(x = x_n, I = 1)$.

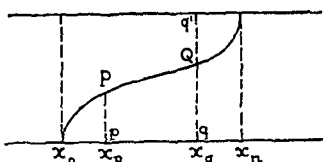

FIG. 10.

If we construct the curves $z = f'(x)$ by means of such simple ground-forms, the two values of $f'(x)$ corresponding to the same value of x in the two-valued domain have opposite signs. Accordingly in the two branches we travel along the axis of x in opposite directions.

The contribution to the frequency in a segment between p and q then consists of two parts:

$$\Delta_1 I = \frac{1}{\sqrt{\pi}} \int_{x_p}^{x_q} f_1'(x) e^{-[f_1(x)]^2} dx \quad \text{and} \quad \Delta_2 I = \frac{1}{\sqrt{\pi}} \int_{x_q}^{x_p} f_2'(x) e^{-[f_2(x)]^2} dx,$$

both of which are positive; they must be added to obtain the total frequency.

For the integral-curve this means that the ordinate $I = \Phi(x)$ is considered as the difference of the two ordinates

$$\Phi_1(x) = \frac{1}{\sqrt{\pi}} \int_{-\infty}^x f_1'(x) e^{-[f_1(x)]^2} dx \quad \text{and} \quad \Phi_2(x) = \frac{1}{\sqrt{\pi}} \int_{-\infty}^x f_2'(x) e^{-[f_2(x)]^2} dx.$$

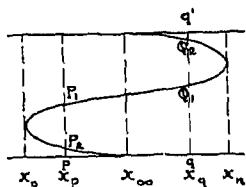

FIG. 11 a.

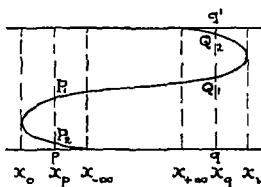

FIG. 11 b.

The integral-curve now assumes either the form of fig. 11a, or that of fig. 11b, depending on the function being two-valued in the whole domain or only in

a part of it. We therefore have to construct the curve in such a way that

$$pP_1 - pP_2 = P_1P_2 = pP \quad (\text{fig. 11 and 10})$$

and

$$Q_1q' - Q_2q' = Q_1Q_2 = Qq' \quad (\text{ " " " " })$$

or

$$qQ_1 + Q_2q' = qQ \quad (\text{ " " " " })$$

Obviously it is still possible to satisfy the above conditions in a great many ways. On one hand the problem becomes theoretically indeterminate (as a necessary consequence of giving up the provisional simplifications). On the other hand we gain the possibility of simplifying the curve $I = \Phi(x)$ and with it the curve $z = f(x)$ as much as possible. Once the form of the curve (I, x) has been determined, the curve $z = f(x)$ may be drawn with the aid of the table (I, z) .

When the frequency-figure is symmetrical with regard to the median, so that $x_m = \frac{x_0 + x_n}{2}$, it is natural to construct the curve $I = \Phi(x)$ in such a manner, that $(x = x_m, I = \frac{1}{2})$ becomes the centre. The curve $z = f(x)$ will also have a centre, viz. in the point $(x = x_m, z = 0)$.

If the frequency-curve is not symmetrical but higher in the left half of the domain than in the right, then in the figure $z = f(x)$ the point of intersection with the axis of x ($z = 0$) will lie in the left half of the figure.

The reaction-function has now the form of fig. 12a or that of fig. 12b.

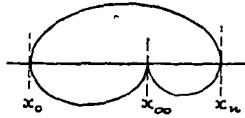

FIG. 12a

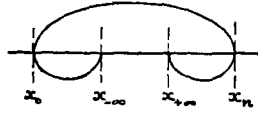

FIG. 12b.

In $x = x_0$ we have $f'(x) = \infty$. Assuming the radius of curvature

$$\rho = \frac{\{1 + [f'(x)]^2\}^{3/2}}{f''(x)}$$

to be finite, $f''(x)$ must be infinite of the same order as $[f'(x)]^3$. For the reaction-function

$$\eta = \psi(x) = \frac{1}{f'(x)}$$

we have

$$\frac{d\eta}{dx} = \psi'(x) = \frac{-f''(x)}{[f'(x)]^2}$$

Hence in the point $x = x_0$ also $\psi'(x)$ will have an infinite value, so that the reaction-curve touches the ordinate-lines $x = x_0$ and $x = x_n$ in the points $(x = x_0, \eta = 0)$ and $(x = x_n, \eta = 0)$ resp.

C. Three-valued functions $z = f(x)$.

A frequency-series with a summit at only one or at both extremities may, as we have seen, be rather easily connected with a two-valued function $z = f(x)$. Likewise a function, which is three-valued in a part of the real domain, may be used for examining a frequency-series with two discontinuities *within* the limits.

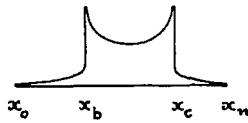

FIG. 13.
and $f'(x_c) = \infty$.

Here we suppose a frequency-figure of the form of fig. 13. If the discontinuities (infinite ordinates in the ideal frequency-curve) are found at $x = x_b$ and $x = x_c$, the function $z = f(x)$ must have branch-points there, so that $f'(x_b) = \infty$

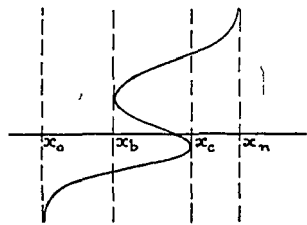

FIG. 14

Besides the curve $z = f(x)$ must also extend to the left of x_b and to the right of x_c .

So we arrive, intricate forms being not considered, at a curve of the shape of fig. 14.

The function has three branches $f_1(x)$, $f_2(x)$ and $f_3(x)$. The lower branch ranges from x_0 (corresponding to $z = -\infty$) to x_c ; In this branch $f_1'(x)$ is always > 0 .

The middle branch extends from x_c to $x_b (< x_c)$ in a negative direction along the axis of x ; in this branch $f_2'(x) < 0$.

The upper branch extends from x_b to x_n (corresponding to $z = +\infty$); in it $f_3'(x)$ is always > 0 .

So the function is three-valued in the segment $x_b \dots x_c$.

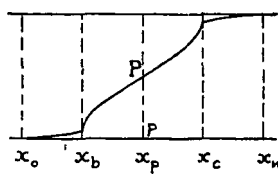

FIG. 15.

In the integral-curve $I = \Phi(x)$, as it follows directly from the observations (see fig. 15), the ordinate in the interval $x_0 \dots x_b$ slowly increases from 0 to I_b (which is a small value).

Then the ordinate suddenly rises, so that in the integral-curve (x_b, I_b) is a corner, of which the left hand tangent is nearly horizontal, the right hand one vertical. Thereupon the slope decreases to its minimum in the point of inflexion to rise again to an exceedingly high value at x_c . Here the ordinate attains the value I_c , which differs but little from unity. Finally the ordinate still slightly increases from I_c to unity. So the integral-curve has another corner at (x_c, I_c) , the tangent being vertical on the negative side, nearly horizontal on the positive.

Now the frequency in the interval $p \dots q$, belonging to the three-valued zone, consists of three parts, viz. :

$$\Delta_1 I = \frac{1}{\sqrt{\pi}} \int_{x_p}^{x_q} f_1'(x) e^{-[f_1(x)]^2} dx, \quad \Delta_2 I = \frac{1}{\sqrt{\pi}} \int_{x_q}^{x_p} f_2'(x) e^{-[f_2(x)]^2} dx,$$

$$\Delta_3 I = \frac{1}{\sqrt{\pi}} \int_{x_p}^{x_q} f_3'(x) e^{-[f_3(x)]^2} dx,$$

which are all positive, because we travel along the axis of x in a negative sense in the part $(\Delta_2 I)$, where $f'(x) < 0$.

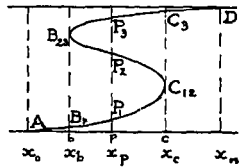

Now for $x_b < x < x_c$ the integral

$$\Phi(x) = \frac{1}{\sqrt{\pi}} \int_{-\infty}^x f'(x) e^{-[f(x)]^2} dx$$

FIG. 16 may be broken-up into three parts :

$$\Phi_1(x) = \frac{1}{\sqrt{\pi}} \int_{-\infty}^x f_1'(x) e^{-[f_1(x)]^2} dx, \quad \Phi_2(x) = \frac{1}{\sqrt{\pi}} \int_x^{x_b} f_2'(x) e^{-[f_2(x)]^2} dx,$$

$$\Phi_3(x) = \frac{1}{\sqrt{\pi}} \int_{x_b}^x f_3'(x) e^{-[f_3(x)]^2} dx$$

The function $\Phi_1(x)$ is represented by the part AB_1C_{12} , the

function — $\Phi_2(x) = \frac{1}{\sqrt{\pi}} \int_x^{x_b} f_2'(x) e^{-[f_2(x)]^2} dx$ by the part $C_{12}B_{23}$, the

function $\Phi_3(x)$ by the part $B_{23}C_3D$.

The total frequency $I = \Phi(x_p)$ in the point $x = x_p$, is therefore represented by

$$I = pP_1 - pP_2 + pP_3 = pP_1 + P_2P_3 = pP_3 - P_1P_2 = pP \text{ (see fig. 15 and 16).}$$

So we may put the following problem :

To transform the discontinuous integral-curve (fig. 15) furnished directly by observation into a continuous curve (fig. 16), which in the range $x_b \dots x_c$ has three branches, such that

$$pP_1 + P_2P_3 = pP,$$

or what comes to the same,

$$pP_3 - P_1P_2 = pP,$$

where pP is the ordinate in the given discontinuous curve.

Also this construction is in a great measure indeterminate. This vagueness may be utilised to satisfy conditions of a non-mathematical character.

The construction having been carried out in some way or other, for each value of I the conjugate value of z may be determined and the curve $z = f(x)$ may thus be constructed, which will then show the shape of fig. 14.

The reaction function looks as fig. 17.

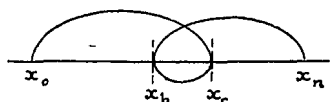

FIG. 17.

The transformation of the observed integral-curve into the theoretical one may also be interpreted in this way: In the point $x = x_p$ the observed integral-curve has for ordinate the total frequency of the values $x < x_p$, i.e. the quotient of the whole number of individuals for which $x < x_p$, divided by the number N of all the individuals.

The theoretical ordinate pP_1 in the branch Φ_1 represents the frequency of the values $x < x_p$ as far as these are due to the branch f_1 of the function f , i.e. to the branch $\eta_1 = \frac{1}{f_1}$, of the reaction-function. The final ordinate cC_{12} then represents the quotient of the whole number of values $x < x_c$, that is of all values due to the first branch, divided by N .

From C_{12} onwards the second branch of the reaction-function begins to play a part. New values of x now appear between x_c and x_b ($< x_c$). The number of values of x between x_p and x_c , which are thus added, amounts to N times the increase of the ordinate from C_{12} to P_2 . On the other hand the increase from P_2 to B_{23} represents the quotient of the number of values x ($x_b < x < x_p$) as far as due to the second branch, divided by N . Accordingly the increase from B_{23} to P_3 represents the N^{th} part of the number of values of x , which, lying between x_b and x_p , are due to the third branch. Hence the increase from P_2 to P_3 , or the segment P_2P_3 represents the N^{th} part of the number of values of x lying between x_b and x_p , as far as due to both the second and the third branch. Adding to this the ordinate pP_1 , we obtain the N^{th} part of the total number of values of x that are inferior to x_p . Now in the observed integral-figure this number was represented by the ordinate pP . Hence the relation

$$pP = pP_1 + P_2P_3,$$

which may also be written:

$$pP = pP_3 - P_1P_2.$$

If the two points of discontinuity $x = x_b$ and $x = x_c$ are very near each other, they may appear as a single accumulation in the rough frequency-curve.

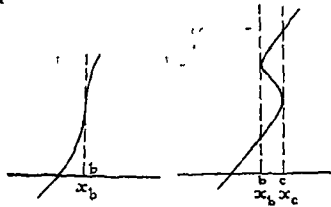

Fig. 18 a.

Fig. 18 b.

The former (simplified) analysis then required a very steep slope in the curve $z = f(x)$ at this point, by which the smooth character of the curve is often disturbed (fig. 18a).

Considering however this accumulation as a fusion of two discontinuities, we may assume that the function is three-valued in the immediate vicinity of $x = x_b$ (fig. 18b). Usually the smooth transition may be obtained by freehand drawing. Care must however be taken that the three-valued zone remains as narrow as possible.

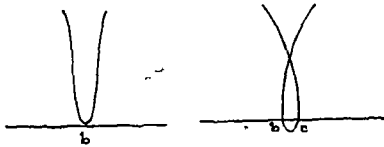

Fig. 19 a.

Fig. 19 b

The reaction-curve must now be modified in such a way that in the point b the reaction becomes neither very small and positive, nor zero,

but negative.

So instead of the shape of fig. 19a the reaction-curve obtains the shape of fig. 19b.

Astronomy. — “*Calculation of Dates in the Babylonian Tables of Planets*”. By DR. A. PANNEKOEK. (Communicated by E. F. VAN DE SANDE BAKHUYZEN).

(Communicated in the meeting of September 30, 1916)

By the researches of F. X. KUGLER S. J. in Valkenburg we have for some years been acquainted with the methods and results of Babylonian astronomy during the period of its highest development. The material for this was provided by a number of more or less damaged fragments of clay tablets covered with cuneiform writing, which are preserved in the British Museum, and which have been very carefully copied, by STRASSMAIER. They contain observations and calculations made in advance of the places of the moon and planets from the 5 centuries before the Christian Era, the complete deciphering and explanation of which is given by KUGLER in his work “*Die babylonische Mondrechnung*” (1902) and in Vol. I of his larger work “*Sternkunde und Sterndienst in Babel*” (1907).

The tables of the planets and especially those of Jupiter; which are reproduced and examined in the latter work, show how highly developed the methods of the Babylonian astronomy of those centuries were, with a character of their own differing completely from the contemporaneous Greek and from modern astronomy. The astronomers of Babylon knew not only the regular alternation of direct and retrograde motions of the planets in each synodic period, but they also knew that besides this they do not circulate uniformly in the ecliptic. The calculation of this variable velocity, a consequence of the elliptic motion, was for the Greek astronomers a geometric problem, which they solved by excentric circles and goniometric functions (chords). The Babylonians endeavoured to achieve the same result by purely arithmetical methods. The chief reason of this difference was, undoubtedly, that the Babylonian science, being, as a part of the general religious teaching, the duty of the priest, had no occasion to develop new ideas regarding the position of the celestial bodies in space; its object could, therefore, be no other than by certain mathematical methods to transfer as well as possible to future years, the regular return of periods and variations from the previously observed places in the heavens.

For Jupiter, KUGLER found three kinds of tables. They all contained originally (even though only fragments are left), in five columns beside each other, the heliac rise, the first station, the opposition, the second station and the heliac setting for all the successive periods of Jupiter. For each of these phenomena is given: the year (according to the Seleucidian era, which begins 312 B. C.), date (month and day), longitude of the planet, (sign of the zodiac, degrees, minutes). They differ in the way in which the figures in the tables are calculated; the first kind is the roughest, the third the most accurate. If the planet described a circular orbit the construction of such a table were simple enough; each opposition would take place 398,884 days after the previous one and at a longitude $33^{\circ}8'37''5$ larger, and the same interval would hold good for the other special phenomena. In consequence of the elliptical motion the intervals are not always of the same length. Now in the tables of the first kind KUGLER found the following arithmetical process made use of to find the longitude of the planet. In the region of the ecliptic from 240° to 85° longitude (30° m to 25° r) 36° is taken as the synodic arc; from 85° to 240° an arc of 30° is taken. If a synodic arc falls partly in one and partly in the other region, a value between these two is taken. If, for instance, one of the phenomena (e.g. the opposition) falls in a certain year on the

longitude $215^{\circ}35'$, of the next synodic arc $24^{\circ}25'$ will still fall in the region of the 30° , $5^{\circ}35'$ would project beyond and belong to the region of 36° and must therefore be increased by $\frac{1}{6}$ of its value i.e. by $1^{\circ}7'$; the whole arc is then $31^{\circ}7'$ and the following year the same phenomenon takes place at longitude $246^{\circ}42'$. By each time adding a synodic arc calculated in this way, the whole series of values is calculated from the original value. The mean value for the synodic arc which is assumed in this arithmetical process is $33^{\circ}8'45''$, only deviating very slightly from the truth, while as the point of greatest velocity a longitude of $342^{\circ}30'$ was found.

The second kind of tables differ from the first in this, that between the two regions of 30° and 36° transition regions are inserted (from 219° to 272° and from 47° to 99° long.) where the synodic arc is taken $= 33^{\circ}45'$. Except for this the calculation is made in the same way. The tables of the third kind, on the other hand, exhibit a more refined method. The velocity, the value, therefore, of the synodic arc, and also the time-interval between two successive oppositions or stationary points (after subtraction of a lunar year of 354 days or 12 lunar months), here increases and decreases gradually: in the Babylonian tables these differences appear in two separate columns. Their rise and fall is not, as in the geometric method, sinusoidal but abrupt; uniform rising up to a certain limiting value and then uniform diminution; which means that the deviation of the accepted positions from a uniform motion is represented by a continuous series of parabolic curves open alternately upwards and downwards. The time-interval between two successive oppositions varies between $50^{\text{d}}7^{\text{h}}15^{\text{m}}$ (sexagesimal subdivision of the days) and $40^{\text{d}}20^{\text{h}}45^{\text{m}}$, while after each period it increases or diminishes by $1^{\text{d}}48^{\text{h}}$; the time of revolution along the ecliptic contains therefore $\frac{2 \times 9^{\text{d}}46^{\text{h}}30^{\text{m}}}{1^{\text{d}}48^{\text{h}}} = 10^{\frac{31}{36}}$ periods, that is $= 11^{\frac{31}{36}}$ years. The extreme values for the synodic arc are $38^{\circ}2'$ and $28^{\circ}15'30''$, while here also two successive values differ by $1^{\circ}48'$. The mean value for the synodic arc here as in both the other kinds of tables being $33^{\circ}8'45''$, corresponds to a periodic time of Jupiter of $11 \frac{1370}{1591}$ years, of which the former is an approximate value.

In this manner KUGLER has traced out the rules according to which the longitude of the successive oppositions, stationary points and annual rising and setting of Jupiter was calculated by the Babylonian astronomers. He has, however, paid less attention to the rules for calculating the dates belonging to them in the tables.

With reference to the Jupiter tables of the first kind he says on this head: "Die Regel, welche der Verfasser unserer Tafel bei der Berechnung der Daten befolgte, lässt sich nicht klar erkennen; dagegen ist es nicht schwer, das Bildungsgesetz der Längen festzustellen" ¹⁾. In the tables of the third kind the way to find the dates seems to be indicated by the accompanying column of time-intervals; but here also difficulties arise. For if from the synodic period belonging to the Babylonian values 398.890 the mean value of the time-interval $45^{\text{d}}14^{\text{I}} = 45^{\text{d}}.233$ is subtracted, $353^{\text{d}}.657$ results, hence not a lunar year of $354^{\text{d}}.367$ but $0^{\text{d}}.71$ less. The excess of the synodic period beyond the each time tacitly added 12 lunar months is only $44^{\text{d}}.52$, this should, therefore, have been added each time to the previous date, instead of $45^{\text{d}}.23$. Moreover the nature of the Babylonian calendar renders it difficult to calculate the dates in this way. The months have as a rule alternately 29 and 30 days, but occasionally a day must be added (in 30 lunar years 11 days), sometimes, therefore, 2 months of 30 days follow one another; and by this irregularity the whole scheme of calculation, which looks so simple, is upset. Moreover, in the fact that the dates are given in days only, without subdivisions, lies an indication that they were found in a different and simpler way. KUGLER points out that 1 Jupiter period is the same as 13 Babylonian months + 15 days all but $\frac{1}{12}$ day or also = $13\frac{1}{2}$ Babylonian months + $0^{\text{d}}.23$, the same 0.23 which occurs in the mean value of the time-interval $45^{\text{d}}.23$, and that, starting from this principle, a continuous Jupiter calendar might be made, without regard to the varying length of the months. If errors of a single day remained, this was not of consequence for the object of the planet tables ²⁾. In how far these surmises were true will appear from the following.

II.

It would seem a priori to be improbable that the column containing the time-intervals so carefully worked out should not have been made use of at all in the calculation of the dates. We can moreover put this to the test. The difficulty here lies in the uncertainty as to how long each of the months was which lie between two successive dates. On this account we will leave this point for the present undecided. In the following table, a portion of the Jupiter table of the 3rd kind Sp. II 46, the successive dates (2nd station-

¹⁾ KUGLER, Sternkunde u. Sterndienst in Babel. I. S. 121.

²⁾ KUGLER. l. c. S. 166—169.

ary point) are given (the names of the months are indicated by their numbers in Roman figures, the years are those of the Seleucidian era), preceded by the time-interval according to the table and followed by the difference of the dates. This difference is always a year, increased by one or two months, increased or decreased by some number of days.

Time-interval	Year	Date	Interval between the dates
41 ^d 46 ^l 5	190	XII 11	1 year + 1 ^m + 11 ^d
40 43	191	XIII 22	" + 2 - 18
42 31	193	II 4	" + 1 + 12
44 19	194	III 16	" + 2 - 15
46 7	195	IV 1	" + 1 + 16
47 55	196	V 17	" + 2 - 12
49 43	197	VII 5	" + 1 + 20
48 43.5	198	VII 25	" + 2 - 12
46 55.5	199	IX 13	" + 1 + 17
45 7.5	200	IX 30	" + 2 - 15
43 19.5	201	XI 15	" + 1 + 13
41 31.5	202	XII 28	" + 2 - 18
40 58	204	I 10	" + 1 + 11
	205	II 21	

We see here immediately that the varying time-intervals from the first column have certainly been used, as the calculated intervals of the dates rise and fall simultaneously with them. The sum of all the time-intervals from the first column is 579^d40^l, the interval between the first and last date is 14 years 2 months and 10 days, which, taking into consideration 5 inserted months (191, 194, 197, 199, 202 were leap-years with 13 months) is equal to 175 months and 10 days. The mean of these 13 time-intervals is $\frac{579^{\text{d}}.67}{13} = 44^{\text{d}}.59$,

the mean difference between 2 successive dates is $\frac{175 \times 29.5306 + 10}{13} = 398.30$, thus 43^d.93 more than a lunar year; here again, therefore, the tabular values for the time-interval appear to be 0^d.7 greater than the excess of the actual synodic intervals above a lunar year.

If, however, we now take the sum of the intervals in the last column, the riddle is solved; we find 13 years + 19 months + 10 days. The two last terms are precisely equal to the sum of the first column, $579\frac{2}{3}$ days, if only for each of the 19 months a value of 30 days is assumed. From this it follows

that in the calculation of the Babylonian planet tables normal months of 30 days were assumed.

In this way the difficulty was overcome of not knowing beforehand in the compilation of the tables, which months would have 29 days and which had 30. This of course applied only to the surplus of the Jupiter period beyond the lunar year of 354.37 days. If this surplus was 44 days, 1 month + 14 days was always added in the following year, no matter what the name of the month; therefore either the following month was taken with a date 14 greater or the next but one month with a date 16 smaller. To prevent getting more and more behindhand with the true calendar with its share of shorter months in this way, the number of inserted days had to be taken larger in the same proportion as the normal month of 30 days exceeded the mean length of the true calendar months (29,5 days). The actual mean Jupiter period is according to the data of these tables 398.8895 days; that is $44^d.5224$ more than the mean lunar year 354.3671. If this excess is equal to x real lunar periods, $x \times 30$ must be taken in its place in order on the average to remain equal with the calendar. This $x \times 30 = \frac{44.5224 \times 30}{29.5306} = 45.23$ days, the Babylonian astronomer, to be able

to apply his method of calculation, had to add to the previous date each following year. And actually the mean interval of time in the tables that lies half way between the extreme values $50^d7^h15^m$ and $40^d20^h45^m$ is exactly $45^d14^h = 45^d.233$.

The regularly varying time-intervals given in the tables have, therefore, actually been used for forming the dates. But how? It is not probable that values rounded off to days were used for the intervals: as a matter of fact this would not give the results of the table. It is more probable that the time-intervals with their fractions were constantly added to the dates already found and from the list so obtained the fractions were finally omitted. We do not know what fractions were assumed at the starting point of the tables; if we suppose that the first date in the table must be called 190 Adaru 11 12^I, we obtain the results that are brought together in the following table. In the 3rd column "date calculated" the date is calculated in 60th parts of a day, starting from the above mentioned

44

Proceedings Royal Acad. Amsterdam. Vol. XIX.

value and adding each time the time-interval of the 1st column. As all months are reckoned as 30 days it is only necessary to add the excess of each time-interval over and above 30, while, every time that we come to more than 30, 30 is subtracted.

TABLE I.
From the Jupiter table of the 3rd kind Sp. II 46 (Kugler p. 152).
D. Second stationary point.

Time-interval	Date	Calc. date	Time-interval	Date	Calc. date
41 ^d 46 ^h 5	190 XII 11	11 ^d 12 ^h		211 IX 1	1 10.5
	191* XIII 22	22 58.5 ^a	46 40.5	212 X 18	17 51
40 43	193 II 4	3 41.5	44 52.5	213* XII 3	2 43.5
42 31	194* III 16	16 12.5	43 4.5	214 XII (16)	15 48
44 19	195 IV 1	0 31.5	41 16.5	216* I (27)	27 4.5
46 7	196 V 17	16 38.5	41 13	217 II (8)	8 17.5
47 55	197* VII 5	4 33.5	43 1	218* III 21	21 18.5
49 43	198 VII 25	24 16.5 ^b	44 49	219 IV 5	6 7.5 ^a
48 43.5	199* IX 13	13 0	46 37	220 V 23	22 44.5
46 55.5	200 IX 30	29 55.5	48 25	221* VII 11	11 9.5
45 7.5	201 XI 15	15 3	50 1.5	222 VIII 2	1 11 ^c
43 19.5	202* XII 28	28 22.5	48 13.5	223 IX 21	19 24.5
41 31.5	204 I 10	9 54	46 25.5	224* XI 7	-5 50
40 58	205* II 21	20 52	44 37.5	225 XI 22	20 27.5
42 46	206 III 4	3 38	42 49.5	227† I 5	3 17
44 34	207 IV 18	18 12	41 1.5	228 I 16	14 18.5
46 22	208† VI 4	4 34 ^a	41 28	229* II 27	25 46.5
48 10	209 VI 23	22 44	43 16	230 III 10	9 2.5
49 58	210* VIII 13	12 42	45 4	231 IV 25	24 6.5
48 28.5					

The dates of the Babylonian table prove, with little exception, to agree with the dates of the third column when rounded off to the nearest whole number of days. In 4 cases the Babylonian date is 1 different (*a* too small, *b* too large), while from the year 222 (*c*) onwards all dates deviate in the same direction by 1—2 days from

* Leap years with 2nd Adaru (XII). † Leap-years with 2nd Ululu (VI).

the calculation. Whereas in the four cases clerical errors of the Babylonian copyists are not impossible, the permanent deviation in the last 9 values points to an error of calculation, as, once an error has been made in the addition, this error is carried on in all the subsequent values. Probably (as may easily occur in the Babylonian method of writing figures) the difference 50 1 30 was read as 51 30, whereby all subsequent dates would become 1^d28.15 too large.

III.

We will now proceed to the calculation of dates in the Jupiter tables of the first and the second kind. KUGLER has converted the data of table Sp. II 101, the largest of the first kind, into Julian dates; if we take the successive differences between these, they vary so irregularly between $365 + 37$ and $+ 29$ days, that to search for the method of calculation seems indeed hopeless. If, however, guided by what we found in the tables of the third kind, we assume that a normal month of 30 days is used in the calculations all the time, a much greater order and regularity immediately appear in the differences. These differences, which in Table II are placed in the 2nd column, show the same character as the differences of longitude: a number of times a greatest value of 48^d alternates with a smallest one of 42^d, in the same intervals as for the longitude synodic arcs of 36° and 30° alternate, while at the points of transition intermediate values appear (See table II p. 692).

It is natural to assume the same method of calculation for these intermediate values as for those in the longitude, viz. as long as the planet stands in the region of 30°, the time-interval 42^d holds, and as long as it stands in the region of 36°, 48^d holds. Then the number of days of the time-interval must always be exactly 12 more than the number of degrees of the synodic arc. The following list shows that this is not always the case.

	Second stationary point					Heliacic setting			
Time-interval :	42	47	43	46	44	45	44	46	43
Syn. arc + 12 :	43.3	45.9	43.1	45.1	43.9	44.9	43.2	45.8	42.4

In the first case the cause of the difference is the synodic arc having been calculated wrong; to the starting point 0°25' in a synodic arc of 30°5' belongs, so that the time-interval 42 is correct. But amongst the others there are 4 with deviations of 1 day. This, therefore, requires further elucidation, which was only found after

44*

TABLE II.

From the Jupiter table of the 1st kind. Sp. II 101 (Kugler p. 119).

D. Second stationary point.

Year	Date	Time-interval	Longitude	Synod. arc	Period. number	Date calculated
134*	II 22	42	0°25' ♃	30° 0'	21	21
135	III 4	42	0 25 ♎	31 17	3	3
136	IV 16	48	1 42 ♋	36 0	15	16
137*	VI 4	48	7 42 ♎	36 0	27	4
138	VI 22	48	13 42 ♎	36 0	9	22
139	VIII 10	48	19 42 ♏	36 0	21	10
140*	IX 28	48	25 42 ♏	36 0	3	28
141	X 16	47	1 42 ♏	33 53	15	16
142*	XII 3	42	5 35 ♏	30 0	28	3
143	XII 15	42	5 35 ♏	30 0	10	15
145*	I 27	42	5 35 ♏	30 0	22	27
146	II 9	42	5 35 ♃	30 0	4	9
147	III 21	43	5 35 ♎	31 7	16	21
148*	V 4	48	6 42 ♋	36 0	28	4
149	V 22	48	12 42 ♎	36 0	10	22
150	VII 10	48	18 42 ♎	36 0	22	10
151†	VII 28	48	24 42 ♏	36 0	4	28
152	IX 16	48	0 42 ♏	36 0	16	16
153*	XI 4	46	6 42 ♏	33 3	28	4
154	XI 20	42	9 45 ♏	30 0	11	20
156*	I 2	42	9 45 ♏	30 0	23	2
157	I 14	42	9 45 ♏	30 0	5	14
158	II 26	42	9 45 ♃	30 0	17	26
159*	IV 8	44	9 45 ♎	31 57	29	8
160	IV 22	48	11 42 ♋	36 0	11	22
161	VI 10		17 42 ♎		23	10

TABLE II. (Continued) E. Heliac setting.

Year	Date	Time-interval	Longitude	Synod. arc	Period. number	Date calculated
135	VII 13		14°40' η		29	13
136	VIII 28	45	17 36 \rightarrow	32°56'	11	28
137 [†]	X 16	48	23 36 \rightarrow	36 0	23	16
138	XI 4	48	29 36 \approx	36 0	5	4
139	XII 22	48	5 36 γ	36 0	17	22
141	I 10	48	11 36 δ	36 0	29	10
142*	II 28	48	17 36 Π	36 0	11	28
143	III 12	44	18 50 σ	31 14	24	12
144	IV 24	42	18 50 δ	30 0	6	24
145*	VI 6	42	18 50 η	30 0	18	6
146	VI 18	42	18 50 ρ	30 0	0	18
147	VII 30	42	18 50 η	30 0	12	30
148*	IX 16	46	22 36 \rightarrow	33 46	24	16
149	X 4	48	28 36 \rightarrow	36 0	6	4
150	XI 22	48	4 36 λ	36 0	18	22
151 [†]	XII 10	48	10 36 γ	36 0	0	10
153*	I 28	48	16 36 δ	36 0	12	28
154	II 16	48	22 36 Π	36 0	24	16
155	III 29	43	23 0 ¹⁾ σ	30 24	6	29
156*	IV 11	42	23 0 δ	30 0	18	11
157	IV 23	42	23 0 η	30 0	0	23

an examination of the tables of the 2nd kind had shown the way.

From the large Jupiter table of the 2nd kind, which consists of 5 fragments fitting together Sp. II 574, Sp. II 42, Sp. II 107, Sp. II 68 and Sp. II 876, we have put the dates together in table III (the missing ones are represented by numbers in brackets · these numbers were inserted by KUGLER; as will be shown his conjecture usually agrees with the result of our calculations), as well as the longitudes and the synodic arcs ²⁾).

¹⁾ Kugler's value 23 36 (difference thus 31 0) is copied erroneously from the cuneiform writing, where 23 0 stands

²⁾ Of the longitudes also many are missing owing to damage of the cuneiform texts; but KUGLER was able to reconstruct them with complete certainty.

TABLE III.

From the Jupiter table of the 2nd kind Sp. II 574 etc. (KUGLER p. 128).

A. Heliac rise.

Year	Date	Time- Int.	Longitude	Syn. arc	Reduc. date	L.—R.D.	Period. numb.	Calc. date
180*	VI 13		10° 0' ♀					
		42		30° 0'	1	9 0	3	13
181	VI 25		10 0 ♀					
		42		30 7½	1	9 0	15	25
182	VIII 7		10 7½ ♀					
		45		33 45	1	9 7½	27	7
183*	IX 22		13 52½ →					
		47		34 47½	4	9 52½	9	22
184	X 9		18 40 ♀					
		48		36 0	9	9 40	21	9
185	XI 27		24 40 ≡					
		48		36 0	15	9 40	3	27
186*	XIII 15		0 40 ♀					
		48		36 0	21	9 40	15	15
188	II 3		6 40 ♂					
		47		35 3¾	27	9 40	27	3
189†	III 20		11 3¾ ♀					
		46		33 6¼	2	9 3¾	9	20
190	IV 6		14 10 ♀					
		41		30 0	6	8 10	22	6
191*	V 17		14 10 ♀					
				30 0	5	9 10	4	18 a
192	V (30)		14 10 ♀					
				30 0			16	30
193	VII (12)		14 10 ♀					
				30 38¾			28	12
194*	VIII (25)		14 48¾ ♀					
				33 45			10	24
195	IX (10)		18 33¾ →					
				35 6¼			22	10
196	X (27)		23 40 ♀					
				36 0			4	27
197*	XII (15)		29 40 ≡					
				36 0			16	15
199*	I 3		5 40 ♀					
		48		36 0			28	3
200	I 21		11 40 ♂					
		46		36 0	3	8 40	10	21
201	III 7		15 45 ♀					
		45		34 5	7	8 45	22	7
202*	IV 22		18 20 ♀					
		42		32 35	10	8 20	4	22
203	V 4		18 20 ♀					
		43		30 0	10	8 20	16	4
204	VI 17		18 20 ♀					
		42		30 0	11	7 20	29	17
205*	VII 29		18 20 ♀					
		43		30 0	11	7 20	11	29
206	VIII 12		19 30 ♀					
		45		31 10	12	7 30	23	12
207	IX 27		23 15 →					
		48		33 45	15	8 15	5	28 a
208†	X 15		28 40 ♀					
		48		35 25	21	7 40	17	15
209	XII 3		4 40 ♂					
		48		36 0	27	7 40	29	3
210*	XIII 21		10 40 ♀					
				36 0	3	7 40	11	12

Year	Date	Time- Int.	Longitude	Syn. arc	Reduc. date	L. R.D.	Period. numb.	Calc. date
212	II 9	48	16°40' γ	36°0'	9	7 40	23	9
213*	III 25	46	20 25 $\frac{1}{4}$ Π	33 45 $\frac{1}{4}$	13	7 25 $\frac{1}{4}$	5	25
214	IV 9	44	22 30 σ	32 4 $\frac{3}{4}$	15	7 30	17	9
215	V 21	42	22 30 Ω	30 0	15	7 30	29	21
216*	VII 3	42	22 30 μ	30 0	15	7 30	11	3
217	VII 15	42	22 30 ϕ	30 0	15	7 30	23	15
218*	VIII 30	45	24 11 $\frac{1}{4}$ μ	31 41 $\frac{1}{4}$	18	6 11 $\frac{1}{4}$	6	30
219	IX 15	45	27 56 $\frac{1}{4}$ \rightarrow	33 45	21	6 56 $\frac{1}{4}$	18	15
220	XI 3	48	3 40 \approx	35 43 $\frac{3}{4}$	27	6 40	0	3
221*	XII 21	48	9 40 χ	36 0	3	6 40	12	21
223	I 9	48	15 40 γ	36 0	9	6 40	24	9
224*	II 27	48	21 22 $\frac{1}{2}$ γ	35 42 $\frac{1}{2}$	15	6 22 $\frac{1}{2}$	6	27
225	III 13	46	25 7 $\frac{1}{2}$) Π	33 45	19	6 7 $\frac{1}{2}$	18	13
226	IV 26	43	26 40 σ	31 32 $\frac{1}{2}$	20	6 40	0	26
227†	VI 8	42	26 40 Ω	30 0	20	6 40	12	8
228	VI 20	42	26 40 μ	30 0	20	6 40	24	20
229*	VIII 3	43	26 40 ϕ	30 0	21	5 40	7	3
230	VIII 17	44	26 40 μ	32 12 $\frac{1}{2}$	23	5 52 $\frac{1}{2}$	19	17
231	X 3	46	28 52 $\frac{1}{2}$ γ	33 47 $\frac{1}{2}$	27	5 40	1	3
232*	XI 21	48	2 40 \approx	36 0	3	5 40	13	21
233	XII 9	48	8 40 χ	36 0	9	5 40	25	9
235*	I 27	48	14 40 γ	36 0	15	5 40	7	7
236	II 15	48	20 40 γ	35 23 $\frac{3}{4}$	21	5 3 $\frac{3}{4}$	19	15
237*	III 30	45	26 3 $\frac{3}{4}$ γ	33 45	24	5 48 $\frac{3}{4}$	1	30
238	IV 13	43	29 48 $\frac{3}{4}$ Π	31 1 $\frac{1}{4}$	25	5 50	13	13
239	V 25	42	0 50 Ω	30 0	25	5 50	25	25
240*	VII 7	42	0 50 μ	30 0	25	5 50	7	7
241	VII 20	43	0 50 μ	30 0	26	4 50	20	20

1) In the cuneiform text the reading is 17 30; the difference shows that this is 10' too high.

Year	Date	Time- Int.	Longitude	Syn. arc	Reduc. date	L.-R.D.	Period. numb.	Calc. date
242	IX (6)		3°33 $\frac{3}{4}$ ' \rightarrow	32°43 $\frac{3}{4}$ '			2	5
243*	X (21)		7 40 \wp	34 6 $\frac{1}{4}$			14	21
244	XI 9		13 40 \equiv	36 0	9	4 40	26	9
245	XII 27	48	19 40 χ	36 0	15	4 40	8	27
247	I 15	48	25 40 ψ	36 0	21	4 40	20	15
248*	III 2	47	0 45 Π	35 5	26	4 45	2	2
249	III 15	44	4 30 σ	33 45	28	6 30	14	18 <i>a</i>
250	IV 1	45	5 0 Ω	30 30	1	4 0	26	1
251*	VI 13	42	5 0 \equiv	30 0	1	4 0	8	13

B. First stationary point.

Year	Date	Time- Int.	Longitude	Syn. arc	Period. numb.	Calc. date
180*	X (17)		26°13' \equiv		21	17
181	X (29)		26 13 \equiv	30° 0'	3	29
182	XII 13		28 24 $\frac{3}{8}$ η	32 11 $\frac{3}{8}$	15	13
183*	XIII 29	46	2 10 \wp	33 45 $\frac{5}{8}$	27	29
185	II 17	48	8 10 \equiv	36 0	9	17
186*	IV 5	48	14 10 χ	36 0	21	5
187	IV 23	48	20 10 ψ	36 0	3	23
188	VI (11)		25 35 $\frac{5}{8}$ δ	35 25 $\frac{5}{8}$	15	10
189†	Vib 26		29 20 $\frac{5}{8}$ Π	33 45	27	26
190	VIII 9	43	0 25 Ω	31 4 $\frac{3}{8}$	9	9
191*	IX 21	42	0 25 \equiv	30 0	21	21
192	X (3)		0 25 \equiv	30 0	3	3
193	XI 16		0 25 η	30 0	16	16
194*	XIII 1	45	3 5 $\frac{5}{8}$ \rightarrow	32 40 $\frac{5}{8}$	28	1
196	I (17)		7 10 \wp	34 3 $\frac{3}{8}$	10	17
197*	III 5		13 10 \equiv	36 0	22	5

Year	Date	Time- Int.	Longitude	Syn. arc	Period. numb.	Calc. date
198	III (23)		19°10' χ	36° 0'	4	23
199*	V (11)		25 10 ν	36 0	16	11
200	V 28		0 16 ⁷ / ₈ Π	35 6 ⁷ / ₈	28	28
201	VII 14	46	4 17 ⁷ / ₈ σ	33 45	10	14
202*	VIII 26	42	4 35 Ω	30 33 ¹ / ₈	22	26
203	IX 8	42	4 35 η	30 0	4	8
204	X 21	43	4 35 ρ	30 0	17	21
205*	XII 3	42	4 35 μ	30 0	29	3
206	XII 17	44	7 36 ⁷ / ₈ \rightarrow	33 17 ⁷ / ₈	11	18 α
208†	II 5	48	12 10 γ	34 23 ¹ / ₈	23	5
209	II 23	48	18 10 \approx	36 0	5	23
210*	IV 11	48	24 10 χ	36 0	17	11
211	IV 29	48	0 10 δ	36 0	29	29
212	VI (16)		4 58 ¹ / ₈ Π	34 48 ¹ / ₈	11	15
213*	VIII 1	42	8 43 ¹ / ₈ σ	33 45	23	1
214	VIII 13	42	8 45 Ω	30 17 ⁷ / ₈	5	13
215	IX 25	42	8 45 η	30 0	17	25
216*	XI 7	42	8 45 ρ	30 0	29	7
217	XI 20	43	8 45 μ	30 0	12	20
218*	XIII 6	46	12 28 ¹ / ₈ \rightarrow	33 43 ¹ / ₈	24	6
220	I 23	47	17 10 γ	34 41 ⁷ / ₈	6	23
221*	III 11	48	23 10 \approx	36 0	18	11
222	III 29	48	29 10 χ	36 0	0	29
223	V 18	49	5 10 δ	36 0	12	17 α
224*	VII 3	45	9 39 ³ / ₈ Π	34 39 ³ / ₈	24	3
225	VII 18	45	12 55 σ	33 15 ⁵ / ₈	6	18
226	VIII 30	42	12 55 Ω	30 0	18	30
227†	IX 12	42	12 55 η	30 0	0	12
228	X 24	42	12 55 ρ	30 0	12	24

Year	Date	Time- Int.	Longitude	Syn. arc	Period. numb.	Calc. date
229*	XII 8	44	13°24 ³ / ₈ ' \mathfrak{m}	30°29 ³ / ₈ '	25	8
		46		33 45		
230	XII 24	47	17 9 ³ / ₈ \rightarrow	35 0 ⁵ / ₈	7	24
232*	II 11	48	22 10 \mathfrak{y}	36 0	19	11
233	II 29	48	28 10 \approx	36 0	1	29
234	IV 17	48	4 10 \mathfrak{v}	36 0	13	17
235*	VI 5	46	10 10 \mathfrak{y}	34 10 ⁵ / ₈	25	5
236	VI 21	45	14 20 ⁵ / ₈ Π	32 44 ³ / ₈	7	21
237*	VIII 6	42	17 5 \mathfrak{e}	30 0	19	6
238	VIII 18	42	17 5 \mathfrak{Q}	30 0	1	18
239	IX 30	42	17 5 \mathfrak{w}	30 0	13	30
240*	XI 12	43	17 5 \mathfrak{z}	31 0 ⁵ / ₈	25	12
241	XI 25		18 5 ⁵ / ₈ \mathfrak{m}	33 45	7	25
243*	I (11)		21 50 ⁵ / ₈ \rightarrow	35 19 ³ / ₈	20	11
244	I 29		27 10 \mathfrak{y}	36 0	2	29
245	III (17)		3 10 \mathfrak{X}	36 0	14	17
246†	V 5	48	9 10 \mathfrak{v}	36 0	26	5
247	V 23	46	15 10 \mathfrak{y}	33 51 ⁷ / ₈	8	23
248*	VII 9	43	19 17 ⁷ / ₈ Π	32 13 ¹ / ₈	20	9
249	VII 22	43	21 15 \mathfrak{e}	30 0	2	23 <i>a</i>
250	IX 5	42	21 15 \mathfrak{Q}	30 0	14	5
251*	X 17		21 15 \mathfrak{w}	30 0	26	17

C. Opposition.

(Only the last part of this table is sufficiently undamaged to be used).

230	I 9	46	8°55' \mathfrak{m}	33°44 ³ / ₈ '	1	9
231	II 25	47	12 39 ³ / ₈ \rightarrow	34 42 ⁵ / ₈	13	25
232*	IV 12	49	17 22 \mathfrak{y}	36 0	25	12
233	IV 31	47	23 22 \approx	36 0	7	30 <i>a</i>
234	VI 18	48	29 22 \mathfrak{X}	36 0	19	18
235*	VIII 6		5 22 \mathfrak{y}	36 0	1	6

Year	Date	Time-Int.	Longitude	Synod. arc	Period. numb.	Calc. date
236	VIII 22	46	$9^{\circ} 50\frac{5}{8}'$ II	$34^{\circ} 28\frac{5}{8}'$	13	22
237*	X 8	46	13 5 σ	$33 14\frac{3}{8}$	25	8
238	X 20	42	13 5 Ω	30 0	7	20
239	XII 2	42	13 5 III	30 0	19	2
240*	XIII 14	42	13 5 μ	30 0	1	14
242	I 26	42	13 $35\frac{5}{8}$ III	$30 30\frac{5}{8}$	13	26
243*	III 13	47	17 $20\frac{5}{8}$ \rightarrow	33 45	26	13
244	III 30	47	22 22 γ	$35 13\frac{3}{8}$	8	30
245	V 18	48	28 22 μ	36 0	20	18
246†	VIb 6	48	4 22 γ	36 0	2	6
247	VII 25	49	10 22 γ	36 0	14	24 α
248*	IX 10	45	14 $31\frac{7}{8}$ II	$34 9\frac{7}{8}$	26	10

The time-intervals, derived in the same way using 30^d for each month, show the same character as the synodic arcs: the 48^d and 42^d occur repeatedly several times in succession, just as the synodic arcs are 36° and 30° . The number of intermediate values is in these tables greater than in those of the first kind. Here also it is natural to assume that the intermediate values of the time-interval are calculated in the same way as those of the synodic arc, but the deviations between the first and 12^d + the last are here even more numerous and larger than in the tables of the first kind. Even in the constant extreme values deviations occur; now and then 43 (once 41) and 49 stand in place of 42 and 48.

In order to be able to see, if at least on the average the values for the time-interval increase in the same way as the synodic arcs, they were combined into groups of full degrees and the mean was taken. This showed that

with $30^{\circ}22'$	corresponded	a mean	of $42.^{d}7$	(6 values)
„ 31 15	„	„	43. 3	(6 „)
„ 32 22	„	„	44. 2	(5 „)
„ 33 10	„	„	45. 2	(4 „)
„ 33 45	„	„	45. 6	(15 „)
„ 34 32	„	„	46. 6	(10 „)
„ 35 23	„	„	47. 7	(6 „)

This indicates, that with great approximation the synodic arcs
 $30^\circ \quad 31^\circ \quad 32^\circ \quad 33^\circ \quad 34^\circ \quad 35^\circ \quad 36^\circ$
 correspond to time-intervals, of
 $42 \quad 43 \quad 44 \quad 45 \quad 46 \quad 47 \quad 48$ days.

That this, however, cannot be quite accurate is shown by the following consideration.

From the length of the synodic arc the time-interval to be added may be calculated, according to the formulae

$$\frac{\text{syn. arc} + 360}{360} \times \text{sidereal year} = \text{synodic period}$$

$$\{\text{synodic period} - \text{lunar year}\} \frac{30}{29.5306} = \text{time-interval}$$

This gives for

$$\text{synod. arc} = 30^\circ \quad \text{synod. period} = 395.698$$

$$\text{time-interval} = \frac{30}{29.5306} \times 41.331 = 41.99$$

$$\text{synod. arc} = 36^\circ \quad \text{synod. period} = 401.786$$

$$\text{time-interval} = \frac{30}{29.5306} \times 47.419 = 48.18$$

whereas for the mean value there was already found :

$$\text{syn. arc} = 33^\circ 8' 45'' \quad \text{time-int. } 45^{\text{d}}.23.$$

For the extreme values, therefore, without a great error 42 and 48 may be taken, provided care is taken that the mean value comes out correct. If we take all the time-intervals = the syn. arc + 12 days, the mean value of the time-intervals becomes $45^{\text{d}} 8^{\text{h}} 45^{\text{m}} = 45^{\text{d}}.146$, therefore $0^{\text{d}}.08$ less than it should be. In 12 periods this difference must rise to a day.

The longitudes of Jupiter in the table have resulted from successive summation of all the synodic arcs. If the time-intervals are obtained by adding 12 to the number of degrees of the synodic arc, the dates that result from successive summation of the time-intervals must each time get ahead of the longitude by 12 and thus successively differ with it by $v, v + 12, v + 24, v + 36$ etc. As the degrees of longitude only go to 30, and similarly the dates, the dates must be deduceable from the longitudes by adding

$$v, v + 12, v + 24, v + 6, v + 18, v, v + 12 \text{ etc.}$$

the same five differences constantly recurring.

This, however, as already said, cannot come out exactly; in order to find the character and origin of the remainders, we subtract from the successive dates the series of numbers

$$12 \quad 24 \quad 6 \quad 18 \quad 0 \quad 12 \quad \text{etc.}$$

and compare the results with the longitudes. We then find the numbers which in the table III on page 694 stand in the column "reduced date", beside which the values of the difference "longitude — reduced date" (L.—R. D.) are placed. These values become gradually smaller, altogether 5 days in the course of the whole table. This is exactly as much as it should be to account for the difference between 45.23, the actual mean time-interval, and 45.146, the mean syn. arc + 12. We now see that a correction for this difference is not introduced gradually, but suddenly, by shifting one day each time after 10—13 numbers; this is done at the places where the horizontal lines are put (the first line is uncertain, as there is some error here).

If we leave out these regularly recurring jumps, the differences L.—R. D. everywhere show variations up and down. On the other hand they show a great constancy, if we only pay attention to the whole numbers and not to the fractions. If we may consider a few cases in which this does not come out as erroneous, we find this rule: *the Babylonian calculator found the dates by taking the numbers of the degrees from the calculated longitudes, increasing them successively by the periodic series of numbers $v, v + 12, v + 24, v + 6, v + 18, v, \text{etc.}$, each time after 10—13 periods taking the number v one higher.*

As a final test, in all the sections of the great Jupiter table of the second kind¹⁾ the dates were calculated according to the above rule by means of the periodic series of numbers $v, v + 12$ etc. The few cases, indicated by a , where there is still a day's difference, are not such as to throw a doubt on the correctness of the rule for the calculation that we have found; these are probably due to copying errors or errors of calculation in the cuneiform texts. The first error in the 3rd section, where Duzu 31 stands instead of 30, is undoubtedly of that kind. In the first error of the first section there was a doubt as to where the periodic number had shifted so that either Duzu 6 or Abu 17 must be one day wrong; we have chosen the transition so, that the latter date, the number of which lies at the edge of the illegible damaged part and has therefore perhaps been misread, was taken to be erroneous. The 3rd erroneous number of the 2nd section also lies at the edge of a damaged portion.

If we now return to the Jupiter tables of the first kind, we find that our rule applies there also. In the table II on p. 692 which contains the dates and places for the second stationary point and the

¹⁾ The columns "reduced date" and "L.—R D" have only been computed for the first section, the heliacic rises; the system of calculation having been discovered from these it was not necessary to compute them for the other sections.

heliac setting from this table, the periodic number and the date calculated are placed in the last two columns. The agreement is everywhere complete, except in the first two dates; but here it can be shown, that there is a copying error in the cuneiform text. We found above (p. 691) that the 2nd synodic arc has been calculated wrong: to a starting point of $0^{\circ}25'$ an arc of $30^{\circ}5'$ belongs. How could this error have arisen? If we assume that the first two longitudes have been copied wrong and should be $1^{\circ}25'$, the synodic arc belonging to these would be $30^{\circ}17'$, therefore the 3rd longitude $1^{\circ}42'$ as it stands in the table. And then the dates calculated become at the same time one higher: Airu 22 and Simannu 4 as the table gives them. In this way all the dates agree with the calculation.

The fact that here the method appears of using the whole number of the degrees of the longitude and not the nearest number rounded off upwards or downwards, indicates that this may have been done in the tables of the third kind also. We cannot settle this, because it is of no consequence; for in that case the first number only, from which the summation started, needs to be taken 30^{I} greater.

It appears, thus, that the Babylonian astronomers made use of a very simple arithmetical system in order to deduce at the same time the longitude and the date of particular phenomena of Jupiter. By the use of normal months of 30 days and corresponding enlargement of the mean value to be added, they made themselves independent of the unequal lengths of the calendar months. Having noticed that the periodic alternation in the time-interval between two successive oppositions contained about the same number of days as the alternation in the synodic arc degrees, they were able by a very simple process of reckoning to find the date from the longitude. They might have done the same in the tables of the third kind; then the column of time-intervals would not have been necessary and practically the same result would have been arrived at with less trouble. Theoretically, it is true, the periodic variations in the synodic arc and in the time-interval should differ by the influence of the varying velocity of the sun: this inequality has practically no influence upon the periodicity in the synodic arc, while it increases the phase of the periodicity of the time-intervals by about 20° . The Babylonians were indeed acquainted with this inequality in the velocity of the sun; but in the Jupiter tables they have not taken it into account. Although KUGLER finds an indication in the didactic text SH 279 (81.7.6) that in the tables of the 2nd kind the unequal velocity of the sun was taken into account (p. 149—150), nothing

of this appears in the tables. In the tables of the 3^d kind also, where it would have been quite possible to apply a different periodicity to the time-intervals and to the synodic arcs, this has not been done; they run practically parallel, differing only by an unimportant computational quantity; and the method of calculation which is used in the tables of the first and second kind excludes any possibility of taking into account the varying velocity of the sun.

Chemistry. — "*On the System Mercury-Iodide.*" By Prof. A. SMITS.
(Communicated by Prof. P. ZEEMAN.)

(Communicated in the meeting of September 27, 1916.)

As was already discussed more at length before mercury iodide exhibits a very peculiar phenomenon on being heated, which phenomenon consists in this that after the red phase has been converted to the yellow phase at 127°, the substance remains yellow up to about 188°, but then gradually assumes a more and more pronounced red colour, and finally melts to a dark red liquid at $\pm 255^{\circ},5$. This, combined with the fact that the vapour is colourless or light yellow, tells us that as far as the composition is concerned the solid phase lies between the vapour and the liquid at the three-phase-equilibrium solid-liquid-gas. In virtue of these data a pseudo figure was derived that took these above facts into account, and gave, moreover, an exceedingly simple explanation of the fact that on sudden cooling of the vapour the yellow modification always makes its appearance first.

Yet this figure had a drawback, which was felt by me and also by others, and which gave an indication that the view would still have to be modified somewhat. This drawback consisted in this that it was assumed that above the point of transition the yellow rhombic mixed crystals would continuously pass into red tetragonal ones.

As was communicated in the last paper on this subject, Dr. A. L. W. E. VAN DER VEEN had at my request undertaken the crystallographic study of mercury iodide in the hope that this research would bring the problem nearer its solution. This has actually been the case. By making use of a special sublimation arrangement Dr. v. D. VEEN ¹⁾ has succeeded in making crystals of yellow mercury iodide, 2 cm. long above 127°.2, and in studying them accurately microscopically at different higher temperatures. It then appeared that the originally yellow crystal begins to gradually assume an

¹⁾ Verslag van de gewone vergaderingen der wis- en nat. afd. Kon. Akademie, Vol. XXIV (1916) p. 1557.

orange tint above 200°, which becomes more and more distinct but does not pass into red as formerly seemed to follow from the investigation of a large quantity of powdery HgI_2 . The distinctly orange coloured crystal was converted to a dark red liquid drop at the melting temperature. In this it could be ascertained with perfect

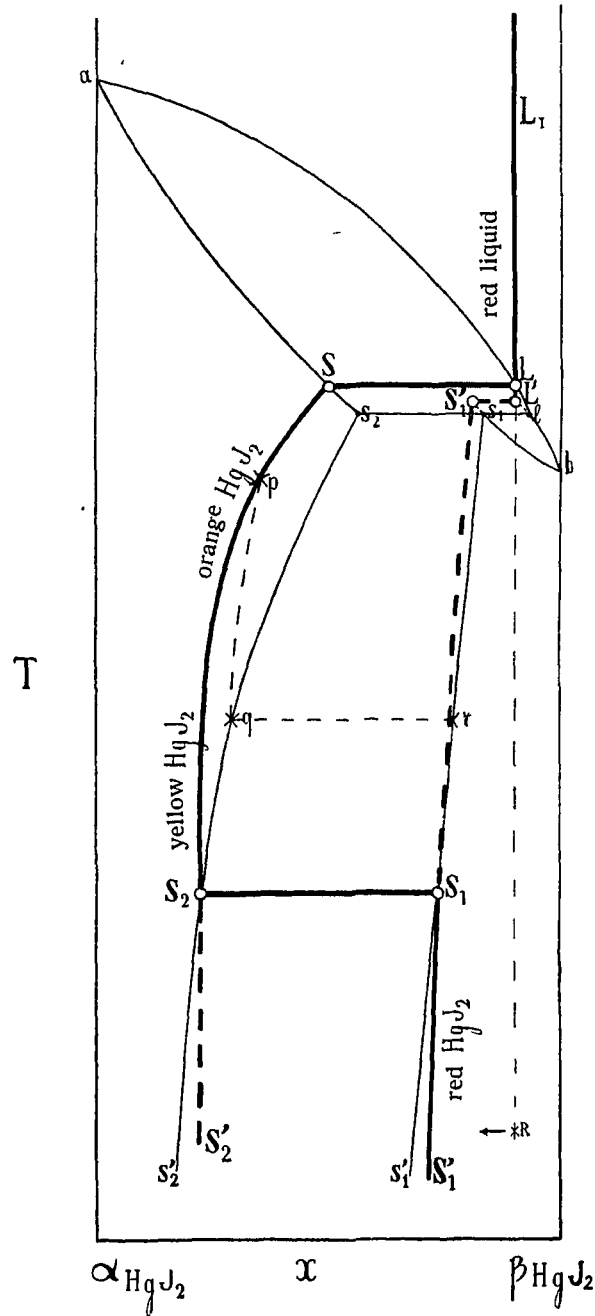

Fig. 1.

certainty that the change of colour from yellow to orange is perfectly continuous, and is not attended with a change in crystalline form, so that the assumption of a continuous transition from rhombic into tetragonal between 127° and 255.5° must be abandoned. It follows therefore from Dr. v. D. VEEN's investigation that: (see p. 703)

1. between 127° and 255.5° the internal equilibrium very perceptibly shifts to the side of the β -component, but the colour proves already that this shifting is not so considerable that the composition of the red modification is reached.

2. this shifting of the internal equilibrium, which is accompanied with a change of colour, is not attended with a change of crystalline form.

These new data rendered it necessary to modify the designed figures of the pseudo- and of the unary system somewhat. Led in this way to reconsider the problem mercury-iodide, I found that the solution was after all exceedingly simple.

One of the particularities presented by the system HgI_2 , is this that as has been stated, the concentration of the solid substance at the triple point solid-liquid-vapour lies between that of the vapour, and the liquid is richest in that component that in the solid red modification is represented in the greater quantity. This is a situation to which we are not accustomed, though it undoubtedly occurs now and then, and it is to be attributed to this that another solution was not immediately thought of, which possesses all the advantages of the former solution, while the objections advanced against the former solution are entirely removed here.

If we begin with the simplest representation, we take the T_x -section of the spacial figures corresponding to a constant pressure, and that such a pressure that equilibria with vapour cannot occur. Now there are two difficulties. The first that I will discuss here is this that the T_x -section has the shape of the figure indicated in thin lines in fig. 1. The pseudo components αHgI_2 and βHgI_2 , therefore, give mixed crystals, but the mixing is limited, hence a continuous transition between mixed crystals of a different crystalline system takes nowhere place. The situation of the unary system in this section has been indicated by thick lines, so that the connection between the pseudo binary and the unary system is at once clear.

The internal equilibrium in the tetragonal red modification is indicated by the line $S_1'S_1$ below the transition point. The internal equilibrium in rhombic modification, which continuously passes from yellow into orange between 127° and 255.5° , is indicated by the line S_2S . Comparatively near below the melting-point this line bends

very perceptibly to the right, which means that the unary mixed crystal becomes richer in the β -pseudo component on rise of temperature. At the moment that the mercury iodide melts, it lies in composition between that of the yellow and of the red modification at the transition temperature.

The liquid L formed is very rich in the β -component, which is in harmony with the fact that the liquid is dark red. The internal equilibrium in the liquid phase above the melting point is indicated by the line LL_1 . What direction this line has cannot be ascertained with any certainty.

The possibility of the occurrence of red mixed crystals *above* the transition point by sudden cooling of HgI_2 from e.g. 240° to 130° is also immediately to be seen from this figure, just as the direct formation of the red modification by sudden cooling of molten HgI_2 in a mixture of carbon dioxide and alcohol.

This is sufficient to show that this figure perfectly accounts for the observed phenomena. To be able also to explain the phenomena that can present themselves in the presence of gaseous HgI_2 , we should also indicate the T_2x -projection of the three-phase regions of the pseudo-system, and then the somewhat unusual situation of the system HgI_2 is apparent.

The vapour coexisting in the triple point with the orange solid phase and the dark red liquid, has a light yellow colour. The vapour is, therefore, richest in the pseudo component αHgI_2 ; consequently the vapour lines in the pseudo system lie as they are indicated in fig. 2. This is, indeed, an unusual situation, which however, will undoubtedly occur now and then. The vapour lines of the unary system are, just as the lines for the solid phases and those for the liquid, indicated by thick lines. What the direction is of the vapour lines and of the liquid line in the unary system, cannot be stated with certainty as yet, but it is of very little importance here ¹⁾.

If we knew that βHgI_2 is a polymer of αHgI_2 , the line for the internal equilibrium in the vapour would run towards higher temperature to the left, but that this case should present itself does not seem very probable, because, as has been said, the liquid at the triple point temperature is richer in the β -component than the coexisting solid phase. The assumption of isomerism, therefore, seems

¹⁾ The vapour lines ag and bg of the pseudo system must intersect in g in such a way that the metastable prolongations do not lie inside each other, as is drawn here, but outside each other. In this case the point G' will also lie exactly on the prolongation of the line G_1G .

to be more likely. This, however, is a question, which cannot be settled until later on. For the present we may be contented to have found a view which explains the observed phenomena in an exceedingly simple and plausible way.

I have pointed out in this paper that there are two possibilities,

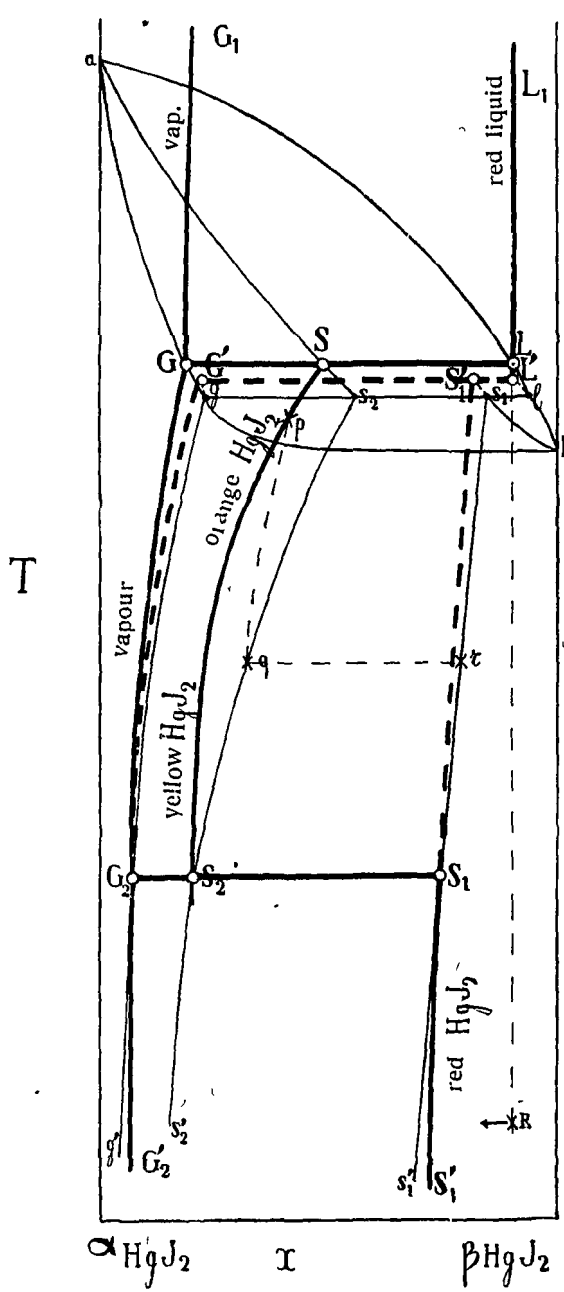

Fig. 2.

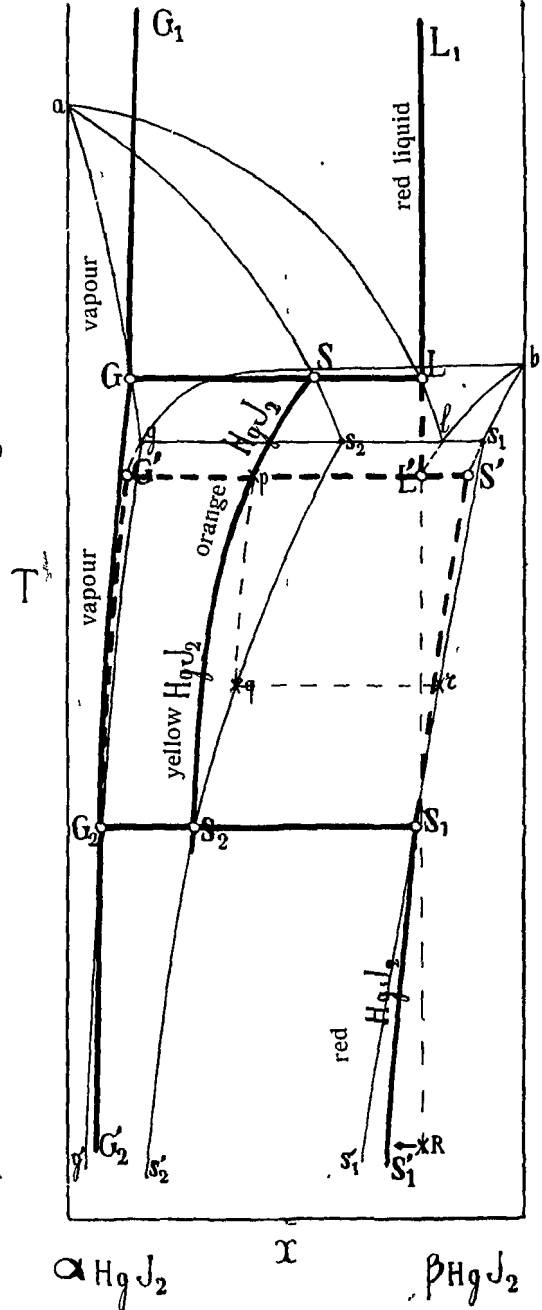

Fig. 3.
45°

of which the first has only been mentioned as yet. The second differs from the first only in this that the melting-point diagram possesses a eutectic point.

Fig. 3 represents in this case the T, x -projection of the three-phase regions of the pseudo system with the two phase regions of the unary system lying in them.

This figure, which does not call for any further elucidation, also represents a case not considered up to now, for which the solid phase lies between the two others on one three-phase region for $S + L + G$, the situation on the other three-phase region being the usual one. At present there is no reason to prefer one representation (Fig. 2) to the other (Fig. 3).

In conclusion it may still be pointed out that as is known, HgI_2 at high temperatures begins to split up appreciably into Hg_2I_2 and I_2 . This splitting up is disregarded here, because evidently it is not essential here for the phenomenon of allotropy.

SUMMARY:

On the ground of new researches a modification was applied to the representation of the system mercuriodide, which has entirely obviated all the former difficulties and in consequence of which an altogether satisfactory concordance with the observed phenomena was obtained.

Anorg. Chem. Lab. of the University.

Amsterdam, Sept. 1916.

Chemistry. — “*On the Influence of the Solvent on the Situation of the Homogeneous Equilibrium*”. I. By Prof. A. SMITS. (Communicated by Prof. F. A. H. SCHREINEMAKERS).

(Communicated in the meeting of October 28, 1916).

1. It is universally known that the solvent frequently greatly influences the situation of the homogeneous equilibrium. This has appeared, for instance in the determination of the equilibria of the *triazol carbonic acid esters* in different solvents, carried out by DIMROTH¹⁾, and from VON HALBAN's²⁾ researches on the conversion

¹⁾ Lieb. Ann. **377**, 133 (1910).

²⁾ Zeitschr. f. phys. Chem. **67**, 129 (1909).

of *para* bromine phenyldimethyl allyl ammonium bromide, besides from the study of the equilibria between the keto- and enol forms of the acetyl acetic ester made by KURT MEIJER¹⁾. In spite of various attempts the explanation of this phenomenon has not yet been found. Yet it seems to me that the solution might be given in the following way.

For this purpose we start from the equation:

$$Z = E - TH + PV \quad \dots \quad (1)$$

When with constant P and T we now differentiate with respect to \bar{n}_1 , we get:

$$\left(\frac{dZ}{dn_1}\right)_{P,T} = \left(\frac{dE}{dn_1}\right)_{P,T} - T \left(\frac{dH}{dn_1}\right)_{P,T} + P \left(\frac{dV}{dn_1}\right)_{P,T} \quad \dots \quad (2)$$

Now

$$\left(\frac{dZ_{n_1}}{dn_1}\right)_{P,T} = \mu_1 \quad \dots \quad (3)$$

It should further be noticed that as we consider solutions here, $\left(\frac{dV}{dn_1}\right)_{P,T}$ is very small.

With regard to P it may be said that when the solvent has a slight vapour tension and the experiment is made in vacuum, this quantity is very small too. But also when an open vessel is used, and P is 1 atm., the term $P \left(\frac{dV}{dn_1}\right)_{P,T}$ is so small, that we may safely neglect it by the side of the others.

Just as in general the entropy may be split up into a concentration entropy and a concentration term, we can write here for the entropy increase when 1 gr. mol. is added reversibly:

$$\left(\frac{dH}{dn_1}\right)_{P,T} = \left(\frac{dH}{dn}\right)_{P,T, C=1} - R \ln C_1 \quad \dots \quad (4)$$

so that we get:

$$\mu_1 = \left(\frac{dE}{dn_1}\right)_{P,T} - T \left(\frac{dH}{dn_1}\right)_{P,T, C=1} + RT \ln C_1 \quad \dots \quad (5)$$

Now on summation over all reacting components, we get:

$$\sum \nu \mu = \sum \nu \left(\frac{dE}{dn_1}\right)_{P,T} - T \sum \nu \left(\frac{dH}{dn_1}\right)_{P,T, C=1} + RT \sum \nu \ln C_1 \quad \dots \quad (6)$$

If we now put:

$$\left(\frac{dE}{dn_1}\right)_{P,T} = E_1 \quad \text{and} \quad \left(\frac{dH}{dn_1}\right)_{P,T, C=1} = H_1 \quad C=1$$

¹⁾ Ber. 47. 832 (1914),

we get

$$\Sigma v_i \mu = \Sigma v_i E_i - T \Sigma v_i H_{i,C=1} + RT \Sigma v_i \ln C_i \quad (7)$$

If we now bear in mind that in the state of equilibrium:

$$\Sigma v_i \mu = 0 \quad \text{and that} \quad RT \Sigma v_i \ln C_i = RT \ln K_C$$

it follows from (7) that:

$$RT \ln K_C = - \Sigma v_i E_i + T \Sigma v_i H_{i,C=1}$$

or

$$\ln K_C = - \frac{\Sigma v_i E_i}{RT} + \frac{\Sigma v_i H_{i,C=1}}{R} \quad (8)$$

Before we proceed it should be pointed out that $\Sigma v_i E_i$, which quantity denotes the change of energy at the temperature of observation, is practically independent of the temperature, and may, therefore, be considered as a constant; because the sum of the specific heats of the second member of the equation of reaction diminished with the sum of the specific heats of the first member yields a quantity perfectly negligible here as was lately fully demonstrated by Dr. SCHEFFER¹⁾.

The solution of the problem now under discussion, is exceedingly simple, when the sum of the entropies $\Sigma v_i H_{i,C=1}$ has the same value in the different solvents, at least so little different that the deviations can be entirely neglected by the side of the sums of the energies $\Sigma v_i E_i$ ²⁾.

This case can of course only be expected when the influence of the solvent on the dissolved substance is of exclusively physical nature.

If we, therefore, apply equation (8) to the same equilibrium in two different solvents *I* and *II*, the just mentioned supposition comes to this that in the equations:

$$\ln K_I = - \frac{(\Sigma v_i E_i)_I}{RT} + C_I \quad (9)$$

and

$$\ln K_{II} = - \frac{(\Sigma v_i E_i)_{II}}{RT} + C_{II} \quad (10)$$

the relation:

$$C_I = C_{II} \quad (11)$$

¹⁾ This part of these Proceedings p. 656.

²⁾ This assumption is of the same nature as that introduced by Dr. SCHEFFER in his paper 'On the Velocity of Substitutions in the benzene nucleus'. He assumed there that the "difference in substitution entropy would be zero for the different hydrogen atoms". These Proc. Vol. XV. p. 1118.

holds for the entropy constants, so that, when we put $(\sum v_i E_i)_I = Q_I^s$ and $(\sum v_i E_i)_{II} = Q_{II}$

$$\ln \frac{K_I}{K_{II}} = \frac{Q_{II} - Q_I}{RT} \dots \dots \dots (12)$$

This formula expresses that the difference in situation of the chemical equilibrium in the two different solvents must be ascribed to a difference in heat of reaction.

Now it is at once clear that a difference in thermal effect of the same reaction in different solvents is due to the difference in heat of mixing of the reacting components in the different solvents.

If we, namely, consider the simple conversion :

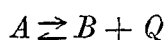

we can think this heat-effect split up into three factors.

1. the differential heat of unmixing of $A = -Q_{M_A}$,
2. the heat of reaction of the conversion of 1 gr. mol. of liquid A in 1 gr. mol. of liquid $B = Q_R$,
- and 3 the differential heat of mixing of $B = Q_{M_B}$;

hence

$$Q = -Q_{M_A} + Q_R + Q_{M_B}$$

We get, therefore, for the heat effects in the two solvents :

$$Q_I = -Q_{M_{A_I}} + Q_R + Q_{M_{B_I}} \dots \dots \dots (13)$$

and

$$Q_{II} = -Q_{M_{A_{II}}} + Q_R + Q_{M_{B_{II}}} \dots \dots \dots (14)$$

so that

$$Q_{II} - Q_I = (Q_{M_{A_I}} - Q_{M_{A_{II}}}) - (Q_{M_{B_I}} - Q_{M_{B_{II}}}) \dots \dots (15)$$

If we now indicate the difference in heat of mixing of A in the two solvents by $Q_{M_{A_I-II}}$, that of B by $Q_{M_{B_I-II}}$, our equation (12)

becomes

$$\ln \frac{K_I}{K_{II}} = \frac{Q_{M_{A_I-II}} - Q_{M_{B_I-II}}}{RT} \dots \dots \dots (16)$$

i. e. the influence of the solvent on the situation of the chemical equilibrium is due to the difference in heat of mixing for the reacting components in these different solvents.

To test this conclusion it will, therefore, be sufficient to determine by the side of the constants of equilibrium the heats of solution

of the reacting substances in different solvents, because the difference in heat of solution of e.g. *A* in different solvents is equal to the difference of heat of mixing.

3. Another conclusion to which the supposition made here leads, is this: It follows from equation (12) that when $K_I > K_{II}$, also $Q_{II} > Q_I$.

If we now differentiate (12) with respect to *T*, we get:

$$\frac{d \ln \frac{K_I}{K_{II}}}{dT} = \frac{Q_I - Q_{II}}{RT^2} = \text{negative.} \quad (17)$$

from which therefore follows that when $K_I > K_{II}$ the difference $\ln K_I - \ln K_{II}$ will diminish on increase of temperature, i.e. the difference in situation of the equilibria in the two different solvents will decrease at higher temperature.

4. It is almost superfluous to point out here that when the supposition $C_I = C_{II}$ is not introduced, we obtain through subtraction of equation (10) from (9) the equation:

$$\ln \frac{K_I}{K_{II}} = \frac{Q_{II} - Q_I}{RT} + C_I - C_{II} \quad (18)$$

which likewise gives

$$\frac{d \ln \frac{K_I}{K_{II}}}{dT} = \frac{Q_I - Q_{II}}{RT^2}$$

on differentiation with respect to *T*, but this equation in itself could not convey any special meaning to us. In virtue of (12) it could be concluded that when $K_I > K_{II}$, also Q_{II} must be $> Q_I$, and this gave rise to the conclusion under 3.

5. In conclusion it may be pointed out that when it should appear that the difference $C_I - C_{II}$ may not be neglected the above given consideration will lead us to the knowledge of this difference, so that at any rate a study in this direction will lead us to a deeper insight in this so important phenomenon.

*Anorg. Chem. Laboratory of the
University of Amsterdam.*

Amsterdam, 17 October.

Chemistry. — “*In-, mono- and divariant equilibria.*” XI. By Prof. F. A. H. SCHREINEMAKERS.

(Communicated in the meeting of October 28, 1916).

18. *Binary systems with two indifferent phases.*

After the general considerations [Communication X] about systems with two indifferent phases, we shall apply them now to binary systems.

When in the invariant point of a binary system occurs the equilibrium: $F_1 + F_2 + F_3 + F_4$, then only one type of P, T -diagram exists; we find it in fig. 2 (I).

When in a binary system, however two indifferent phases occur and, therefore, also two singular phases, then two types of P, T -diagram exist [figs. 1 and 2]. We may deduce them in different ways.

When in the concentration-diagram of fig. 2 (I) F_3 and F_4 are the indifferent phases, then F_1 and F_2 are the singular ones; F_1 and F_2 have then the same composition, so that the points F_1 and F_2 coincide [fig. 1]. Then we have the singular equilibria:

$$(M) = F_1 + F_2 \quad [\text{Curve } (M) \text{ in fig. 1}]$$

$$(F_3) = F_1 + F_2 + F_4 \quad [\text{Curve } (3) \text{ in fig. 1}]$$

$$(F_4) = F_1 + F_2 + F_3 \quad [\text{Curve } (4) \text{ in fig. 1}]$$

and further the equilibria:

$$(F_1) = F_2 + F_3 + F_4 \quad [\text{Curve } (1) \text{ in fig. 1}]$$

$$(F_2) = F_1 + F_3 + F_4 \quad [\text{Curve } (2) \text{ in fig. 1}].$$

We may deduce the type of P, T -diagram from fig. 2 (I). As (3) and (4) are the singular curves, they must, therefore, coincide. It follows from our previous considerations that this coincidence may take place in fig. 2 (I) only in such a way that curve (3) coincides with the prolongation of (4) and therefore also curve (4) with the prolongation of (3). Then we obtain a type of P, T -diagram, as in fig. 1, in which curve (M) is bidirectionable. This diagram contains two bundles of curves; the one bundle consists of the curves (1), (4) and (2), the other only of curve (3). Curve (M) is a middlecurve of the (M)-bundle.

We are able to find the bivariant regions in this P, T -diagram in the same way as in other diagrams. Between the curves (1) and (4) is situated the region (14) = 23, between the curves (1) and (2) we find the region (12) = 34, etc. In fig. 1 those regions are indicated; they are the same as in fig. 2 (I), with this difference, how-

ever, that the region 12 from fig. 2 (I) is missing in fig. 1 and is replaced by the singular curve $(M) = F_1 + F_2$.

We have seen in the previous communication that each region which extends over the stable or metastable part of a singular curve, contains the two indifferent phases. In fig. 1 the region 34 extends over the singular curves; and therefore it contains the two indifferent phases F_3 and F_4 .

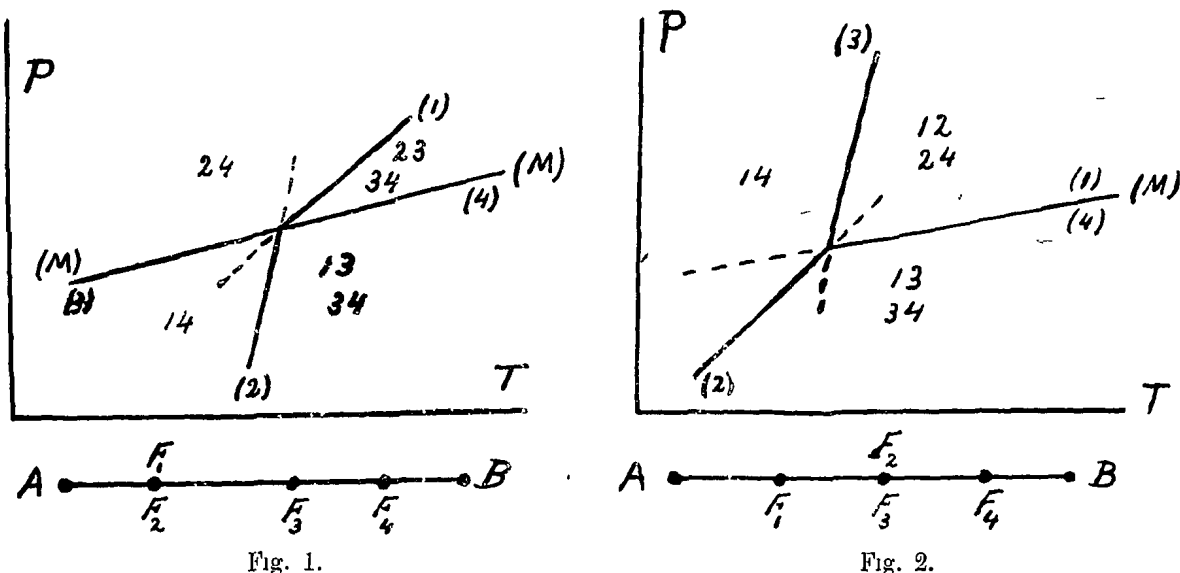

Fig. 1.

Fig. 2.

When in the concentration diagram of fig. 2 (I) F_1 and F_2 are the indifferent phases, then F_3 and F_4 are the singular phases, F_3 and F_4 have then the same composition, so that the points F_3 and F_4 coincide [fig. 2]. Then we have the singular equilibria:

$$(M) = F_3 + F_4 \quad [\text{Curve } (M) \text{ in fig. 2}]$$

$$(F_1) = F_3 + F_4 + F_1 \quad [\text{Curve } (1) \text{ in fig. 2}]$$

$$(F_2) = F_1 + F_3 + F_4 \quad [\text{Curve } (2) \text{ in fig. 2}]$$

and further the equilibria:

$$(F_3) = F_1 + F_2 + F_4 \quad [\text{Curve } (3) \text{ in fig. 2}].$$

When we wish to deduce the type of P, T -diagram from fig. 2 (I) then, as (1) and (2) are the singular curves, we have to let them coincide. Then we obtain fig. 2. The three singular curves (M) , (1) and (2) coincide now in the same direction; the (M) -curve is, therefore, monodirectionable. Consequently the P, T -diagram consists of three onecurval bundles.

In order to find the bivariant regions, we have to bear in mind that between the curves (1) and (3) the region $(13) = 24$ is situated,

between the curves (1) and (2) the region (12) = 34; etc.; then we find the regions indicated in fig. 2. Those regions are the same as in fig. 2 (I); only the region 23 from fig. 2 (I) is missing in fig. 2, it is replaced by the singular curve $(M) = F_2 + F_3$.

In fig. 2 the region 14 extends itself over the metastable parts of the singular curves (M) , (1) and (4); indeed this region contains the two indifferent phases F_1 and F_4 .

Now we have let the phases F_1 and F_2 coincide and also F_2 and F_3 in the concentration-diagram of fig. 2 (I), we might as well have made F_3 and F_4 coincide. Then we obtain however a same type of P, T -diagram as in fig. 1. Consequently only two different types of P, T -diagram may occur; they are represented in figs. 1 and 2.

We are able to deduce the types of P, T -diagram also in the following way. In communication X we have viz. seen that we may distinguish three main types, viz. I, IIA and IIB.

In main type I curve (M) is monodirectionable; the P, T -diagram of a binary system has then the same appearance as that of a unary system. Therefore, it consists, as in fig. 2, of three one-curvical bundles; one of these curves represents then the three singular curves. [In fig. 2 they are the curves (M) , (1) and (4).]

In main type IIA curve (M) is bidirectionable and a middle curve of the (M) -bundle [fig. 3 (X)], we obtain then for a ternary system a type of P, T -diagram as in fig. 1.

In main type IIB curve (M) is bidirectionable and a side-curve of the (M) -bundle [fig. 4 (X)]. As in this type, besides the (M) -curve, still five curves at least have to occur, in binary systems a P, T -diagram of this type cannot exist.

We can also find the types of P, T -diagram with the aid of the reactions, which may occur between the phases of the invariant point.

In order to find the type of P, T -diagram, which belongs to the concentration-diagram of fig. 1, we consider the reactions, which may occur between the phases and the partition of the curves, resulting from those.

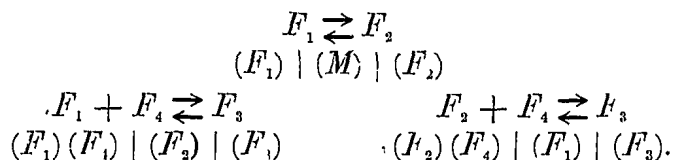

We see that this partition of the curves is in accordance with

fig. 1. It is evident that we can also find easily the type of P, T -diagram with the aid of this partition of the curves.

We find from the concentration-diagram of fig. 2

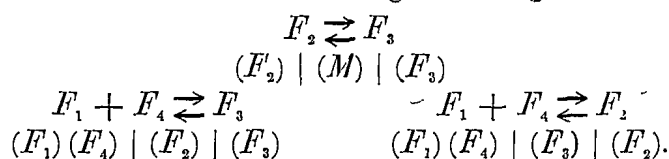

Hence we find a type of P, T -diagram as in fig. 2.

We are also able to deduce the types of P, T -diagram with the aid of the series of signs. In order to find the series of signs, we have to know two reactions, each between the four phases of the invariant point. We can easily deduce those reactions from the concentration-diagrams of figs. 1 and 2; for the concentration-diagram of fig. 1 we find then series of signs 1, for that of fig. 2 the series of signs 2.

Series of signs 1 (fig. 1)

F_1	F_3	F_4	F_2
+	-	+	+
0	-	+	+
-	0	0	+
-	+	-	0

Series of signs 2 (fig. 2)

F_2	F_1	F_4	F_3
+	-	-	+
0	-	-	+
-	0	0	+
-	+	+	0

In series of signs 1 F_3 and F_4 , in series of signs 2 F_1 and F_4 are the indifferent phases; they have opposite signs in series of signs 1 and they have the same sign in series of signs 2. The positions of the curves with respect to one another as in the figs. 1 and 2 follow immediately from those series of signs.

It is apparent from the previous considerations that two types of P, T -diagram [figs. 1 and 2] may occur in binary systems with two indifferent phases. Those types are in accordance with the rules which we have deduced in the general considerations [Communication X]. We found amongst others:

1. The two indifferent phases have the same sign or in other words: the singular equilibrium (M) is transformable into the invariant equilibrium (M) and reversally. Curve (M) is monodirectional; the three singular curves coincide in the same direction. [fig. 1 (X)].

2. The two indifferent phases have opposite sign or in other words: the singular equilibrium (M) is not transformable. Curve (M) is bidirectional, the two other singular curves coincide in opposite direction [fig. 2 (X)].

In order to examine whether the two indifferent phases F_3 and F_4 in fig. 1 have the same sign or not, we take e.g. the reaction:

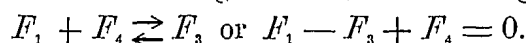

Hence it appears that F_3 and F_4 have opposite signs so that the singular equilibrium $(M) = F_1 + F_2$ is not transformable. Moreover the latter appears also at once from fig. 1; it appears viz. from the position of the points F_1, F_2, F_3 , and F_4 with respect to one another, that a complex of the phases F_1 and F_2 can never be converted into the invariant equilibrium $F_1 + F_2 + F_3 + F_4$.

In accordance with rule 2 curve (M) must be therefore bidirectional and the two other singular curves [(3) and (4)] have to coincide in opposite direction. We see that this is in accordance with fig. 1.

In the same way it appears that the indifferent phases F_1 and F_4 from fig. 2 have the same sign and that the singular equilibrium $(M) = F_2 + F_3$ is transformable. In accordance with rule 1 curve (M) must then be monodirectional and the three singular curves have to coincide in the same direction. This is in accordance with fig. 2.

Now we shall contemplate more in detail some P, T -diagrams. We take a binary system: water + a salt S , of which we may assume that S is not volatile; consequently the gasphase G consists of water-vapour only. When no hydrates of the salt S occur, then we find in the cryohydratic point the invariant equilibrium:

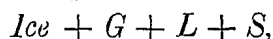

in which L is the solution saturated with ice + S . As the water-vapour G and the ice I [fig. 4] have the same composition, G and Ice are the singular phases, L and S the indifferent ones. Consequently we have the singular equilibria:

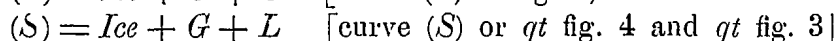
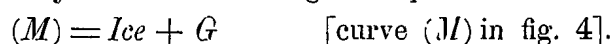

and further the equilibria:

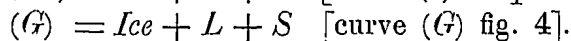
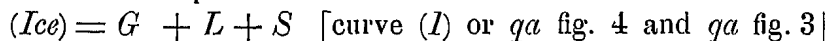

In fig. 3 a concentration-temperature diagram of this binary system is drawn; W and S represent the two components, q is the cryohydratic solution L . The curves qt and qa go towards higher temperatures starting from q ; qt is the ice-curve, it represents the solutions of the equilibrium $(S) = Ice + G + L$; qa represents the solutions, saturated with the salt S , viz. the solutions of the equilibrium

(Ice) = $G + L + S$. Curve qt terminates in the point t : the melting-point of ice under its own vapour-pressure, consequently the triple-point: water + vapour + ice. Curve qa terminates in the melting-point a of the salt S .

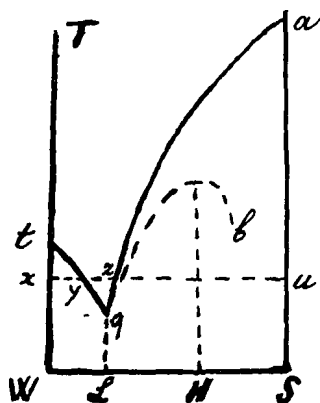

Fig. 3.

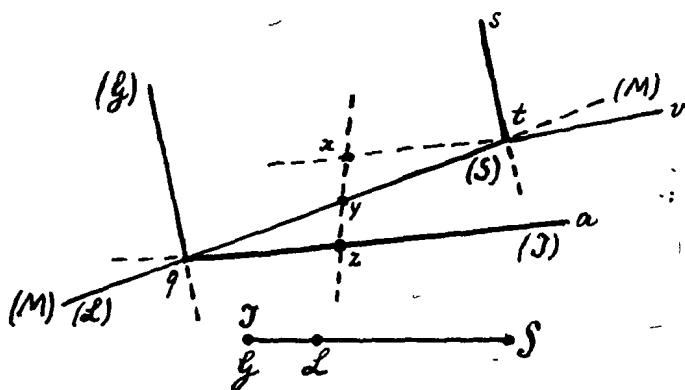

Fig. 4.

We find in fig. 4, besides the P, T -diagram, also the concentration-diagram; as ice and watervapour have the same composition, in this the points I and G coincide.

We find in fig. 4 besides the curves (M) , (L) , (S) , (I) and (G) also the triplepoint t of the water. Three curves start from this triplepoint; tv is the evaporationcurve (equilibrium: water + vapour); ts is the meltingcurve of the ice (equilibrium: ice + water); tq is the sublimationcurve of the ice (equilibrium: ice + vapour). This sublimationcurve tq of the ice is, therefore, at the same time the singular curve $(M) = \text{Ice} + G$ of the binary system.

This (M) -curve is bidirectionable, for the invariant point q of course cannot be a terminating-point of this curve; at the one side of the point q it coincides with the singular curve $(S) = \text{Ice} + G + L$, at the other side of the point q with the singular curve $(L) = \text{Ice} + G + S$.

The reaction $\text{Ice} + S \rightleftharpoons L$ may occur between the phases of curve $(G) = \text{Ice} + S + L$; consequently curve (G) is the common melting-curve of ice and salt S . In general it proceeds upwards starting from the point q fairly parallel to the P -axis. When at the reaction $\text{Ice} + S \rightarrow L$ the volume increases; then it goes starting from q towards higher temperatures; when the volume decreases, it goes towards lower temperatures. In fig. 4 we have assumed that it proceeds, just as the melting-line ts of the ice, starting from q towards lower temperatures.

It follows from fig. 3 that in fig. 4 curve qa must be situated

below qt . For this we draw a horizontal line $xyzu$ in fig. 3; we assume that all the points of this line represent liquids. (Those liquids are then partly stable, partly metastable). In the point x this liquid is water, while the percentage of salt increases starting from x towards u . Consequently the vapourpressure decreases along this line starting from x towards u .

The horizontal line $xyzu$ is represented in fig. 4 by the vertical line $xyzu$, as the vapourpressure in the point u is practically zero, this point has not been drawn in fig. 4; it is situated in the immediate vicinity of the T -axis. The point x is situated on the metastable part of curve tv , point y on curve $(qt) = (S)$ and point z on curve $qa = (I)$. Hence it is apparent that curve qa must be situated, therefore, below qt .

As the concentration-diagram of fig. 4 is the same as that of fig. 1, the P, T -diagram of fig. 4 must belong also to the same type as that of fig. 1. We see that this is the case; both P, T -diagrams [fig. 1 and 4] consist viz. of a threecurvical and a onecurvical bundle; in both diagrams curve (M) is also a middle-curve of the (M) -bundle.

Just as the P, T -diagram of fig. 1 the reader may deduce also that of fig. 4 in different ways; just as in fig. 1 we are able to draw the bivariant regions also in fig. 4. As this figure would be then overfilled with letters, I give in (1) a symbolical representation. [Compare communication IV], The reader may indicate them in a P, T -diagram, which is drawn on a larger scale.

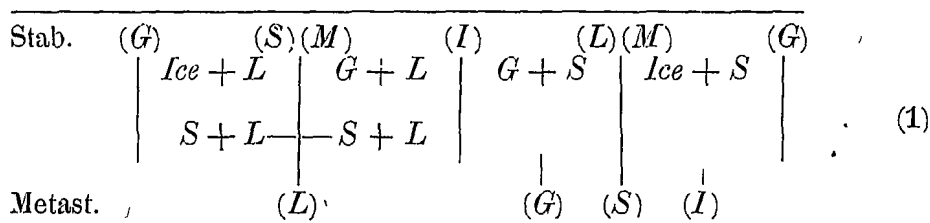

When in the binary system: water + salt S occurs a hydrate H , then the equilibrium:

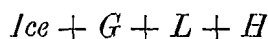

may occur in the cryohydratic point q . When this point H is situated as in fig. 3, in which qb represents the solutions, which are saturated with H under their own vapourpressure, then the P, T -diagram is the same as in fig. 4; in this we have only to replace (S) by (H) and a by b . Curve qb in fig. 4 obtains then in its further proceeding

and further' the equilibria

$$(Ice) = G + L + H \quad [\text{Curve } (I) \text{ or } qa \text{ fig. 6 and } qa \text{ fig. 5}]$$

$$(G) = Ice + L + H \quad [\text{Curve } (G) \text{ fig. 6}]$$

Besides the curves (M) , (L) , (H) , (I) and G we find in fig. 6 also the triplepoint t of the water, ts : the melting-curve of the ice and tw the evaporationcurve of the water.

It appears from a comparison of the figs. 4 and 6 that curve $(S) = qt$ from fig. 4 is replaced in fig. 6 by curve $(H) = qt$. Curve $(L) = qa$, which represents the equilibrium $G + L + H$, proceeds in fig. 4 from q towards higher T and P , in fig. 6 this curve proceeds, however, starting from q towards lower T and P . The metastable part qmb of this curve has its point of maximum temperature in the vicinity of the point m [figs. 5 and 6].

When we draw in fig. 5 the horizontal line $xyzu$ and in fig. 6 the vertical line $xyzu$ corresponding with this then we see that the different curves must be situated with respect to one another, as is drawn in fig. 6.

As the concentrationdiagram of fig. 6 is the same as that of fig. 1, the P, T -diagram of fig. 6 must therefore, belong to the same type as that of fig. 1. We see that this is really the case.

Now we take the binary system: water + salt S , of which S occurs in two modifications S_α and S_β . In fig. 7 q is the solution, saturated with the two modifications under its own vapourpressure. Consequently we have the equilibrium:



Curve $(q\beta)$ [fig. 7] represents the solutions of the equilibrium $G + L + S_\beta$; it terminates in the meltingpoint β of the modification S_β . Curve dq represents the solutions of the equilibrium $G + L + S_\alpha$, the metastable prolongation qa of this curve terminates in the metastable meltingpoint α of the modification S_α .

Curve qo represents the solutions of the equilibrium $S_\alpha + S_\beta + L$; with this we have assumed that this curve proceeds starting from q towards higher temperatures.

We have the singular equilibria:

$$(M) = S_\alpha + S_\beta \quad [\text{Curve } (M) \text{ fig. 8}]$$

$$(L) = S_\alpha + S_\beta + G \quad [\text{Curve } (L) \text{ fig. 8}]$$

$$(G) = S_\alpha + S_\beta + L \quad [\text{Curve } (G) \text{ or } qo \text{ fig. 8 and } qo \text{ fig. 7}]$$

and further the equilibria:

$$(S_\alpha) = G + L + S_\beta \quad [\text{Curve } (S_\alpha) \text{ or } q\beta \text{ fig. 8 and } q\beta \text{ fig. 7}]$$

$$(S_\beta) = G + L + S_\alpha \quad [\text{Curve } (S_\beta) \text{ or } qd \text{ fig. 8 and } qd \text{ fig. 7}]$$

When S_α and S_β are not volatile, then G consists of watervapour only. If they are volatile, then G contains also S . The more S is contained in G , the more the point G shifts towards the right in the concentration-diagram of fig. 8. As long as the four phases with respect to one another are situated, however, as in fig. 8, the P, T -diagramtype remains the same.

As it appears from the change in volume at the reaction $S_\alpha \rightleftharpoons S_\beta$ which is generally small, the (M) -curve proceeds general fairly parallel to the P -axis; it terminates towards lower pressures in the

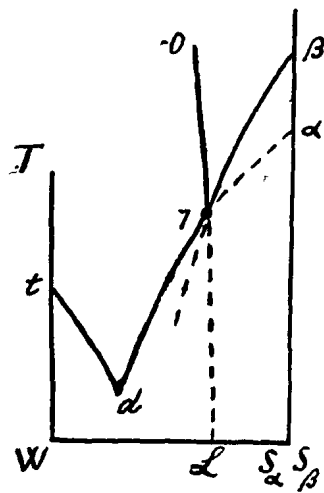

Fig. 7.

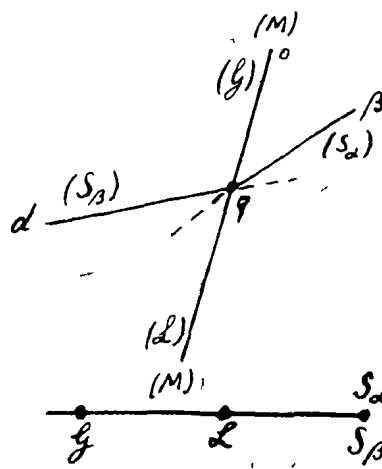

Fig. 8.

triplepoint. $S_\alpha + S_\beta + \text{vapour } S$. It may proceed from this triplepoint as well towards higher as towards lower temperatures; in figs. 7 and 8 we have assumed that it goes towards higher T .

The position of the curves $q\beta$ and qd with respect to one another in fig. 8 follows from fig. 7; for this we have to draw a horizontal line, which intersects the stable part of the one and the metastable part of the other curve.

As the concentration-diagrams of figs. 1 and 8 belong to the same type, this must also be the case with the P, T -diagrams of both figures. We see that this is really the case.

Now we shall discuss a binary system, in which occurs a P, T -diagram of the type of fig. 2. For this we take the system: water + salt S , in which a hydrate H occurs in the two modifications H_α and H_β [fig. 9].

When we represent the solutions of the equilibrium $G + L + H_\alpha$

in a concentration-temperature-diagram, then we obtain a curve $dqaq_1c$ [fig. 9], which has its maximum of temperature in the vicinity of the point α . The curve, which represents the solutions of the equilibrium $G + L + H_\beta$, is represented by $xq\beta q_1z$ (fig. 9); it has its point of maximum temperature in the vicinity of the point β . The curves intersect one another in q and q_1 (fig. 9); in this we have assumed $T_q > T_{q_1}$. The dotted parts of the curves represent metastable conditions.

Now we have two invariant equilibria, viz.

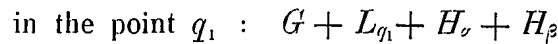

In fig. 9 the solutions of the equilibria $G + L + H_\nu$ and $G + L + H_\beta$ are represented by $dqaq_1c$ and $xq\beta q_1z$; in the P, T -diagram of fig. 10 those equilibria are represented by the same curves. As we have assumed in fig. 9 $T_q > T_{q_1}$, this must also be the case in fig. 10.

The position of those curves in fig. 10 with respect to one another follows from fig. 9. On the horizontal line $dxzc$ viz. the vapour-tension of the liquids decreases starting from d towards c ; in the P, T -diagram the points d, x, z and c must be situated, therefore, with respect to one another, as in fig. 10. When we draw in fig. 9 also other horizontal lines, then we see that the position of the curves dac and $x'z$ in fig. 10 is in accordance with that in fig. 9.

In the point q we have the singular equilibria:

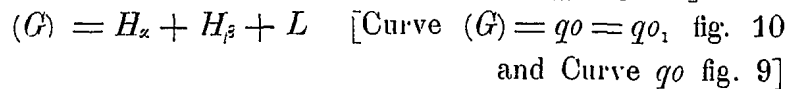
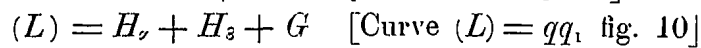

and further the equilibria, already discussed:

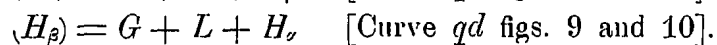
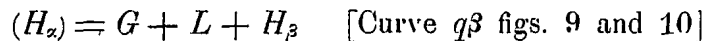

In distinction of the equilibria occurring in q , we give to the equilibria occurring in q_1 the index 1. Then we have in the point q_1 the singular equilibria:

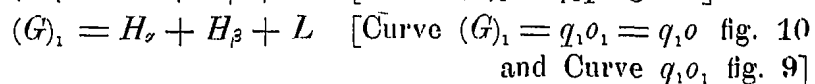
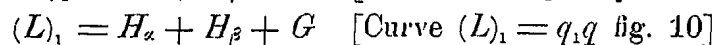

and further the equilibria, already discussed:

$$(H_\nu)_1 = G + L + H_\beta \quad [\text{Curve } q_1\beta \text{ figs. 9 and 10}]$$

$$(H_\beta)_1 = G + L + H_\nu \quad [\text{Curve } q_1c \text{ figs. 9 and 10}].$$

Let us imagine the singular equilibrium $(M) = (M)_1 = H_\nu + H_\beta$ in the point q . It appears from fig. 9 that a complex $H_\nu + H_\beta$ can not be converted into the invariant equilibrium of the point q viz. into $G + L_q + H_\alpha + H_\beta$. [We assume that the gas G consists of watervapour only, so that point G coincides with W]. The singular equilibrium $(M) = (M)_1$ is, therefore, not transformable into the invariant equilibrium q ; curve (M) is consequently bidirectionable and does not terminate, therefore, in the point q , but it goes through that point.

Let us now imagine the singular equilibrium $(M) = (M)_1$ in the point q_1 . It appears from fig. 9 that a complex $H_\nu + H_\beta$ may be-

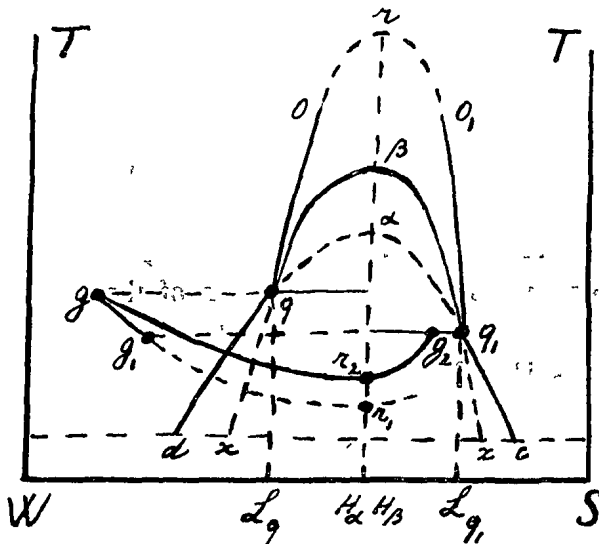

Fig. 9.

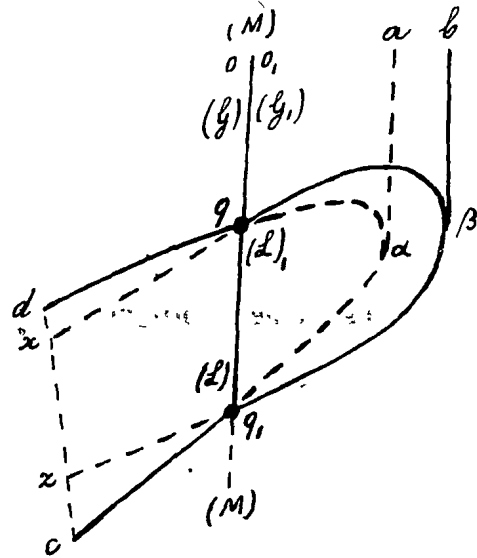

Fig. 10.

converted into the invariant equilibrium of the point q_1 viz. into $G + L_{q_1} + H_\nu + H_\beta$. The singular equilibrium $(M) = (M)_1$, is, therefore, transformable into the invariant equilibrium q_1 ; consequently curve (M) is monodirectionable and terminates in the point q_1 . The (M) -curve is represented, therefore, in fig. 10 by curve $q_1q_0 = q_1q_0_1$.

Further the singular equilibria

$$(L)_1 = H_\nu + H_\beta + G \quad \text{and} \quad (G)_1 = H_\nu + H_\beta + L$$

start from the point q_1 ; as the (M) -curve is monodirectionable in q_1 , the three singular curves (M) , $(L)_1$ and $(G)_1$ coincide in the same direction. The curves $(L)_1$ and $(G)_1$ go, therefore, also, starting from q_1 in the direction towards q .

As the equilibrium $(L)_1 = H_\alpha + H_\beta + G$ may be converted in the point q into the invariant equilibrium q viz. into $G + L_q + H_\alpha + H_\beta$, curve $(L)_1$ terminates in the point q . Consequently curve $(L)_1$ is represented in fig. 10 by curve q_1q .

The equilibrium $(G)_1 = H_\alpha + H_\beta + L$ may not be converted in the point q into the invariant equilibrium $q = G + L_q + H_\alpha + H_\beta$; curve $(G)_1$ does not terminate, therefore, in the point q , but it proceeds further. It is represented in fig. 10 by curve $q_1qo = q_1qo_1$. When we represent the solutions of the equilibrium $(G)_1 = H_\alpha + H_\beta + L$ in fig. 9, then we get a curve as q_1o_1 .

The singular equilibria

$$(L) = H_\alpha + H_\beta + G \quad \text{and} \quad (G) = H_\alpha + H_\beta + L$$

start from the point q . As the (M) -curve is bidirectionable in q , the singular curves (L) and (G) go in opposite direction. Consequently curve (L) goes starting from q towards lower pressures and it terminates in q_1 . Curve (G) goes starting from q towards higher pressures, it is represented in fig. 10 by $qo = qo_1$. The solutions of the equilibrium $(G) = H_\alpha + H_\beta + L$ are represented in fig. 9 by curve qo .

Let us now consider the P, T -diagram in the vicinity of the point q . In this point the equilibrium: $G + L_q + H_\alpha + H_\beta$ occurs, it appears from the position of those phases with respect to one another in fig. 9 that the P, T -diagram must belong to the type of fig. 1. We see that this is really the case.

In the point q_1 the equilibrium $G + L_{q_1} + H_\alpha + H_\beta$ occurs. In accordance with the position of those phases with respect to one another in fig. 9, it is apparent that the P, T -diagram belongs to the type of fig. 2 in the vicinity of the point q_1 in fig. 10.

The curves $qo = (G) = H_\alpha + H_\beta + L$ and $q_1o_1 = (G)_1 = H_\alpha + H_\beta + L$ are no separate curves in fig. 9, but parts of one single curve $qo_1o_1q_1$; this curve has a point of maximum- or of minimum-temperature in its point of intersection r with the line $\alpha\beta$ (viz. with the prolongation of this line). In fig. 9 we have assumed that T is a maximum. In this point r the equilibrium: $H_\alpha + H_\beta + L_{\alpha\beta}$ occurs, in which $L_{\alpha\beta}$ represents a liquid of the composition $H_\alpha = H_\beta$.

In fig. 10 the point r has not been drawn, of course it is situated somewhere on that part of the (M) -curve, which ascends starting from the point q , for we have assumed in fig. 9 $T_1 > T_q$. This point r is the stable terminating-point of the curves qo and q_1o_1 and, as we shall see further, the common point of intersection of three curves viz. of the (M) -curve, of the melting-line of H_α and of the melting-line of H_β .

In the point r viz. the equilibrium: $H_\nu + H_\beta + L_{\alpha\beta}$ occurs; as the melting-line of H_ν represents the equilibrium $H_\alpha + L_{\nu,\beta}$, r is, therefore, also a point of this melting-line. In the same way it appears that r is also a point of the melting-line of H_β .

The melting-line of H_α is represented in fig. 10 by $\alpha\alpha$, that of H_β by $\beta\beta$. The three curves $\alpha\alpha$, $\beta\beta$ and (M) , therefore must go in fig. 10 through a same point r .

In the deduction of fig. 10 we have assumed that the gas-phase G consists of watervapour only; now we shall briefly discuss the case that the compounds H_β and H_ν are also volatile.

Then G contains, besides the watervapour, still the substance S .

When we represent in fig. 9 the compositions of the gas-phases which may be in equilibrium with the liquids of curve dac , then a curve $d'a'c'$ arises, which is not drawn in fig. 9. This curve is the vapourcurve belonging to dac . Also a vapourcurve $x'\beta'z'$ which is not drawn belongs to curve $x\beta z$. Now we assume firstly that the vapours, which are in equilibrium with the liquids, contain less of the substance S than the liquids. Branch $d'a'$ is then situated in fig. 9 more towards the left than $d\alpha$, branch $c'a'$ more than $c\alpha$, branch $x'\beta'$ more than $x\beta$ and branch $z'\beta'$ more than $z\beta$.

The two vapourcurves $d'a'c'$ and $x'\beta'z'$ intersect one another in fig. 9 in g and g_1 ; the vapour g is in equilibrium with the liquid g ; the vapour g_1 with the liquid q_1 . The point g is always situated at the left of the line $\alpha\beta$, the point g_1 may be situated also, however, just as e. g. g_2 at the right of the line $\alpha\beta$. We first consider the case that the vapour, which is in equilibrium with the liquid q_1 , is represented by g_1 .

In the same way as we have deduced above fig. 10, we now find that the P, T -diagram keeps the form of fig. 10.

The vapours of the equilibrium $(L) = H_\nu + H_\beta + G$ and of $(L)_1 = H_\nu + H_\beta + G$ are represented in fig. 9 by curve gg_1 . The equilibrium $H_\nu + H_\beta + G$ has a point of maximum- or of minimum-temperature, when the vapour G has the composition $H_\alpha = H_\beta$. When we produce in fig. 9 curve gg_1 until it meets in r_1 the line $\alpha\beta_1$, then the tangent in r_1 is horizontal. Consequently in r_1 the equilibrium $H_\nu + H_\alpha + G_{\nu,\beta}$ occurs, in which $G_{\nu,\beta}$ represents a vapour of the composition $H_\nu = H_\beta$.

In fig. 10 this point r_1 is situated somewhere on the metastable part of the (M) -curve, viz. on the part, descending starting from the point q_1 . This point r_1 is the metastable terminating-point of the curves (L) and $(L)_1$; at the same time it is, as we easily see,

a common point of intersection of three curves viz. of the (M)-curve, of the sublimation-curve of H_α and of that of H_β . It appears from the position of the vapour-curves $d'a'c'$ and $x'\beta'z'$ with respect to the line $\alpha\beta$ in fig. 9, that the points in which the sublimation-curves come in contact with the curves dac and $x\beta z$ in fig. 10, are situated at the left of q_1 .

As long as the vapour, which is in equilibrium with the liquid q_1 is represented in fig. 9 by a point q_1 at the left of the line $\alpha\beta$, the P, T -diagram keeps a form as in fig. 10. The P, T -diagram changes, however, when the vapour is represented by a point q_2 at the right of the line $\alpha\beta$. The singular equilibrium (M) = $H_\alpha + H_\beta$ is then viz. no more transformable into the invariant equilibrium $q_1 = H_\alpha + H_\beta + G_{q_1} + L_{q_1}$. Curve (M) is then bidirectionable not only in point q but also in q_1 (fig. 10); consequently it proceeds now also in stable condition below the point q_1 . Curve (G)₁ = $H_\alpha + H_\beta + L$ continues to be represented in fig. 10 by q_1o_1 ; curve (L)₁ no more goes now, however, starting from q_1 upwards, but downwards.

The vapours of the equilibria (L) = $H_\alpha + H_\beta + G$ and (L)₁ = $H_\alpha + H_\beta + G$ are represented in fig. 9 by curve gr_2g_2 , which has in r_2 a minimum-temperature. In fig. 10 this point r_2 is situated somewhere on the (M)-curve below the point q_1 . This point r_2 is the stable terminating-point of the curves (L) and (L)₁. [Now curve (L)₁ viz. as has already been said above ascends no more starting from q_1 but it descends]. Point r_2 is also now again the common point of intersection of three curves, viz. of the (M)-curve, the sublimation-curve of H_α and that of H_β . The point in which the sublimation-curve of H_α comes in contact with curve dac , is situated at the left of q_1 ; the point in which the sublimation-curve of H_β touches curve $x\beta z$, is situated, however, at the right of q_1 .

Now the reader may easily draw the changes in the figures 9 and 10, when the vapours, which are in equilibrium with the liquids, contain more of the substance S than the liquids.

(To be continued.)

Leiden, Inorganic Chem. Lab.

Geology. — “*Modifications of the facies in the Tertiary Formation of East Kutei (Borneo)*” by Dr. L. RUTTEN. (Communicated by Prof. Dr. A. WICHMANN.)

(Communicated in the meeting of October 28, 1916).

The coast tract of Kutei is for a width of more than 100 km. occupied by a folded chain of mountains, chiefly built up by rocks of posteocone age. As far as it is hitherto known eocene strata occur only infrequently and in a tectonic connection, which has not yet been sufficiently explained.

It is not astonishing that no detailed stratigraphic subdivision that holds everywhere without modification can be given for the tertiary strata building up this chain of mountains of a length of more than 3000 km. A rough subdivision of the Posteocone into three sections, which will be briefly described below, can however be made for the greater part of the regions.

The oldest part of the posteocone deposits consists chiefly of grey, concretionary shales. Besides these pretty pure siliceous sandstones occur, which are — especially on the lower parts of the formation — thin-laminated. They often contain on the planes of stratification fine scales of coal. Very accessorially limestones are found. In the lower part of the formation they contain, besides small *Lepidocyclinae*, also large specimens of this species, in the higher parts of the formation occur only small *Lepidocyclinae*. The principal characteristic of the formation is of a negative nature: the great scarcity or the absence of coal seams.

This section, embracing the Oligocene and the greater part of the Miocene, is known in South Kutei to the west of the Balik Papan Bay. The entire Pamaluán group and the bottom part of the Pulu-Balang group with an estimated thickness of upwards of 1500 m. are to be considered as belonging to this section¹⁾.

In the neighbourhood of Samarinda the coal-free sandstones and shales to the West of Batu Panggal, which are free from coal, belong to the oldest part of the Miocene²⁾.

In the surroundings of Bontang and Santan only a small portion, valued at about 250 m, has been brought to the surface by the folding.

To the south of the river Sangatta we find at about 25 km. from the coast a deeply folded, domeshaped anticlinal, in which more

¹⁾ Tijdschr. Kon. Ned. Aardr. Gen. (2). 38. 1911, pp. 590 et seq.

²⁾ Jaarb. van het Mijnwezen in Ned. Indië Techn. Adm. Ged. 1887.

than 1000 m. of the older coal-free tertiary formation crops out, whilst in a still larger and deeper folded part between the rivers Sangatta and Bungalan nearly 1500 m. of this formation is to be seen.

In the region of the river Sekurau, where we find likewise a great dome-shaped anticlinal, about 800 m. of the older, coal-free tertiary formation have been brought to the surface.

The second section of the Postocene, consists again partly of hard, grey, concretionary shale and of sandstones which, as a rule, are less pure than in the lower formation. Limestone, and marl-banks occur now and then: they contain almost always corals and small *Lepidocyclinae*. Characteristic of this formation are especially the — most numerous — strata of black shining, scaly breaking coal.

Near Balik Papan this section is represented by the greater part of the Pulu-Balang group and the bottom part of the Mentawir group, together more than 1300 m. thick.

Near Samarinda the coal-bearing mountains of Batu Panggal and the inferior part of the coal formation of Tenggalung Ajam to a thickness of nearly 13000 m. are to be considered as belonging to this section.

Near Bontang the section embraces a complex of strata more than 1500 m. thick, near Bungalan the formation is nearly 1000 m. thick, near Sekurau over 1000 m.

The youngest section of the tertiary formation in East Kutei consists for the greater part of clays and sands with numerous seams of coal and local intercalations of limestones and marls. In contradiction to the two former groups the habitus of the rocks is however much younger. The hard, grey shales especially have been replaced by soft, grey clays, often with impressions of leaves into the planes of bedding. Instead of sandstones we usually find loose sands, and the shining, scaly breaking blackcoal of the older group changes towards the top gradually into dead black and browncoal, and at last even into peaty coal. The limestones and marls are in by far the most cases free from *Lepidocyclinae* and *Miogypsinae*, these fossils occur only in some places in the lower parts of the formation. The thickness of this section — embracing the younger part of the Miocene and the Pliocene — is very important.

Near Balik Papan — where the greater part of the Mentawir group and the Pliocene belong to it — it is more than 2000 m. thick, and near Bontang, Bungalan and Sekurau it has about the same thickness.

The post-eocene deposits between Balik Papan and Sekurau have consequently a thickness of over 4500 m. The facies of these deposits

which we shall call henceforward the *normal facies of the Kutei Tertiary formation*, remains nearly unchanged from the bottom to the top: sandstones and shales prevail greatly; coals can frequently occur among them; limestones and marls, which can locally sometimes become very important, have always a littoral character.

We give here a short scheme of the stratigraphy developed above:

Miopliocene. Sands, loose sandstones, soft, grey shales, very seldom hard clays and even shales, coralligenous limestones and marls, often with very fine fossils, coal from peaty brown to dead black, *Lepidocyclinae* only locally in the deeper parts of the formation. More than 2000 m.

Old-Miocene. Hard, grey shales, loose to hard sandstones black, scaly breaking glance coal (anthracite), coral limestones and marls with small *Lepidocyclinae*. Thickness over 1000 m. and under 2000 m.

Oldest Miocene and ? *Oligocene*. Hard, grey shales, rather pure, quartz-sandstones, which are thinplated in the lower parts of the formation, coal seams entirely or almost entirely absent, limestones and marls at the top with small *Lepidocyclinae*. Thickness about 1500 m.

Even when we stick to this scheme, there remains already abundant room for facial modifications, which are often met with indeed.

In the neighbourhood of Balik Papan e. g. banks of limestones and marls are entirely or almost entirely wanting in the miopliocene. Near Bontang they are plentiful and not bound to a definite level, near Bungalun they are again rare. To the West of the lower part of the river Sekurau littoral strata in the miopliocene are chiefly represented by a thick complex of coral limestones in the centre of the formation.

Coal seams are further exceedingly numerous in the miopliocene near Balik Papan; near Bontang and Bungalun they are much rarer, near Sekurau again very frequent.

Whilst with these facies modifications the general character of the formation remains intact, we find to the East and the North of the river Sekurau transitions of facies that lead us to quite different types of deposits. Guided by the annexed map, in which the principal geological structure lines of this region — the axes of the anticlinals — are indicated, we shall retrace these transitions of facies more particularly.

In a profile through the Sekurau anticlinal directly to the West

and of grey very sandy coral marls containing even sometimes gravel, towards the top they gradually change into the clays, sands and gravels, which constitute to the West of the river Sekuran the youngest part of the tertiary formation. Whereas the group of the calcareous rocks in the miopliocene westward of the river Sekuran has only a thickness of a few hundred meters — and still farther in a western direction quickly diminishes in thickness — it has become in the Sungei Narut, towards the Sekerat Mountains, 1000 m. thick or more. Traces of dead black coal between the coral sands and marls in the Sg. Narut and of transitions between glance coal (anthracite) and dead black coal in the deepest denudation of coral marls in the Sg. Mampang indicate that we have here to do with a modification of facies at a short distance, that the “younger coalbearing tertiary formation with limebanks” to the west of the river Sekuran is replaced by a system of sandy marls and coral limestones, constituting a great part of the Sekerat Mountains.

A transition of facies of much inferior interest in the old-miocene containing glance coal (anthracite) takes place in the neighbourhood of the Sekuran anticline. Whereas in this formation coal strata are still numerous in the southern part of the Sekuran anticlinal, their number rapidly diminishes, so that the older miocene in the Northern part of the Sekuran anticlinal, on the Sembulu anticlinal and on the South and North Sampajau anticlinal is very poor in coal seams. The consequence of this modification of facies is, that in these regions we can no longer separate the “oldest coal-free postocene” and the “old miocene containing glance coal” (anthracite) from each other in a satisfactory manner.

In the centre of the domeshaped Sembulu anticlinal, which is less strongly folded than the Sekuran anticlinal, we find hard shales and sandstones, belonging certainly to the old-miocene containing glance coal (anthracite), though the coal is entirely wanting, — with the exception of a few unimportant seams only some centimeters thick and numerous traces of coal on the planes of the strata of the sandstones. On the Northwestern limb limestones with small *Lepidocyclinae* occur besides the typical sandstones and argillaceous shales. On the South-eastern limb we find — still in the old-miocene and alternating with the hard shales — exceedingly fine strata of usually grey clayey sands and sandy clays which often contain shales. In the Northern part of the Eastern wing these clayey sands change towards the top gradually into a thick system of *Globigerina* marls, sandy and even gravel-containing limestones and grey, clayey sandy marls rich in fossils of a littoral origin. The *Globigerina* marls are

grey to blue, clayey and clayey-sandy, and the strata are for the greater part very imperfect; they often contain bulbs and strata of dense, grey, yellowishly disintegrating marl-limestones. The limestones are partly coralligenous rocks, partly very remarkable lime-sandstones poor in fossils; quartz conglomerates of hornstone with a very abundant cement of calcite; analogous rocks occur likewise in the above described coralligenous limemarl-facies of the Sekerat Mountains. The marls which are very rich in fossils are grey, often very sandy and can easily be separated; they contain besides Globigerinidae many littoral Foraminifera (*Amphistegina*, *Operculina*, *Cyclocypens* and in lower strata also *Lepidocyclina*) and numerous fragments of Corals, Echinids and Molluscs. We shall by-and-by distinguish marls of analogous habitus — though they may partly be of a different age — especially on the Batu Hidup and the Gunung Batu anticlinal, in the river basin of the Lower Sampajau. We shall hereafter indicate these facies constantly as *Sampajau marls*.

On the Northern part of the Eastern limb of the Sembulu anticlinal the superposition of the described strata is thus, that the Globigerinamarls, with a few banks of limestones and Sampajau marls lie deepest; then follows a rather thick complex of limestones, limesandstones and gravellimestones, whilst typical Sampajau marls lie on the top. The total thickness — from the lowest Globigerinamarls to the axis of the synclinal between Sembulu and Maluwi anticlinal — is here about 1200 m.

In this formation occur moreover on the Upper Lemudjau and the Upper Lindak banks of a very remarkable rock — for East Kutei, — which we shall meet afterwards on the Southern limb of the Maluwi anticlinal in the river basin of the Sungei Mangenai, in about the same stratigraphical level. They are white clayey — sometimes sandy — very light volcanic tufas, most likely deposited in an aeolic way. Where the rock is fresh, we see in microscopical preparations, that the principal mass consists of an entangled conglomerate of glass threads, between which mineral splinters of biotite, green hornblende not or little twinned feldspar and most likely also quartz are found. With the naked eye one recognizes from these minerals as a rule only the numerous, idiomorphous biotite scales. The result of a determination of siliceous acid that Mr. MOM, assistant at the agro-geological laboratory at Buitenzorg, was kind enough to make for me, was that a sandy tufa of the Upper Lemudjau contains 72.2% SiO_2 .

We saw that the described limy- (calcareous) marly- tuffaceous formation in the North of the Sembulu anticlinal rests on the old miopliocene; it must consequently be synchronous with part of the

miopliocene that we saw already so remarkably facially modified in the Sekerat Muntains. Perhaps it embraces also still the youngest parts of Old-miocene.

The study of the Maluwi anticlinal gives us still more information in this direction. We saw above, that the vertical distance from the deepest Globigerinaemarls in the Northern part of the Sembulu anticlinal to the youngest Sampajan marls in the synclinal lying eastward, amounts to about 1200 m. From the synclinal to the culmination point of the Maluwi anticlinal there is however over 1700 m. Consequently we should expect, to see in the centre of the Maluwi anticlinal the shales appear again. This is however not the case: the whole of the Maluwi anticlinal is composed of monotonous, grey-blue, clayey sometimes glauconitic marls of Globigerinae and of blue, plastic clays, containing but few layers of quartz sand, and in one spot an extremely thin stratum of glance coal (anthracite). An important part of the old-miocene strata, which occurred on the Sembulu anticlinal still almost exclusively in normal facies, has consequently been developed as Globigerinaemarls in the Maluwi anticlinal lying towards the sea. In the synclinal between Sembulu and Maluwi anticline we discovered still true Sampajan marls; more E.N.E.-ward they are however modified, because the Globigerinae come much more to the front, and at the same time the other fossils recede more backward. In this way we find in the region of Pulu Sangkuwang and Godang marly rocks representing as it were a penetration of the Sampajan marl-facies and the Globigerinaemarlfacies. W. STAUB¹⁾ has described a small fauna of most likely pliocene age. The youngest strata of this region are coralligenous limestones, which come to light at the mouth of the Sungei Tungkap and between the lower course of the rivers Kauli and Lindak.

On the southern limb of the Maluwi anticlinal, lying towards the sea, we do not find back anything of the Sampajan marl-facies; as far as the central part of the Sungei Mangenai exclusively Globigerinaemarls occur here, which contain towards the top banks of the Biotite bearing tufas described above. The Globigerinaemarls are then succeeded at the Sungei Mangenai by coralligenous limestones, which in their turn are covered with a series of sands and gravels — the youngest part of the tertiary formation or perhaps already of quaternary age. These limestones suggest, that towards the end of the tertiary formation the sea slowly receded, a conclusion, which had already been arrived at by W. STAUB (l. c.) on other grounds.

¹⁾ Vierteljahrsschrift der Naturf. Gesellschaft in Zürich. 61. 1916, p. 128 et seq. (The thickness of the Sadgkullirang marls is indicated here too small.)

Now we leave South Sangkulirang and repair to the more northern anticlinals, where we shall likewise find remarkable modifications of facies.

The nuclei of the Southern and Northern Sampanju anticlinals are formed by the Old-Miocene, that contains here remarkably little coal and limestone, but for the rest it is built up of the normal sandstones and shales. On the Western limb of these anticlinals we meet with the Miopliocene, in the South in entirely normal development, in the North with indications of Sampajau marls.

On the Eastern limb we find on the strata of old-miocene likewise miopliocene, partly in the normal development with soft clays, sands, gravel and dead black to brown coal.

In higher parts follow then — in the neighbourhood of Sungei Labuan — between the normal rocks banks of Sampajau marls. In Baŕu and Batu Hidup anticlinal, rising more towards the East the types of the Sampajau marls and limestones obtain a much greater development, though they alternate in the Western limbs still with rather numerous seams of coal. On the Eastern limbs the development of the marly facies is still greater. Sandy clays and sands occur here still in fact, but the coal has almost disappeared. The youngest parts of the tertiary formation consist here of a complex of sands and gravels, — as is likewise the case in the Sembulu anticlinal dipping down towards the North, near Sekurau and southward from the Sungei Mangenai. — We must mention that the miocene Gastropoda, which K. MARTIN¹⁾ described a few years ago from Sangkulirang were collected on the Batu Hidup anticlinal, whilst the fossils described by me from Sankulirang were found on the Gunung Batu anticlinal²⁾. Whilst for these two faunas the age was determined as young miocene, or as transition between old and young miocene, W. STAUB (l. c.) determined the age of the facial analogous fauna of Godang as pliocene. To a certain height these determinations of age are supported by the representation on the map: the strata of fossils of Gelingsch are situated on the farthest anticlinals of the Sangkulirang region, the fauna of Godang was found in the deep synclinal region between the anticlinals of Maluwi and Sembulu and the anticlinals of North Sangkulirang.

We have come to the end of our descriptions and give on the annexed table another geographical-stratigraphical sketch of the facial modifications in the tertiary formation of Sangkulirang.

A few short considerations may be added to the facts described above.

¹⁾ Samml. Geol. Reichsmus, Leiden. (l). 9. 1914, p. 325 e. s.

²⁾ Samml. Geol. Reichsmus, Leiden. (l). 9. 1914, p. 383 e. s.

The normal facies of the Kutei Tertiary formation is undoubtedly for a great part of terrestrial origin; the limestones and marls, which, in proportion to the entire mass of the formation, are always very insignificant, point only to a temporal intrusion of a very shallow sea into the land. The different facies of Sangkulirang (Sekerat facies, Sampajau marl facies and Globigerinaemarl facies) are on the contrary decidedly of a marine origin. Now it is highly remarkable, that the boundary between terrestrial and marine facies in Sangkulirang constantly nearly follows the normal N—S coastline of Kutei. The supposition is suggested that already in great periods of the tertiary formation the present, normal coastline of Kutei — allongated towards the North through Sangkulirang — formed the boundary between land and sea. Exclusively the terrestrial deposits were seized by the “normal” folding, which laid afterwards the tertiary formation into the anticlinals extending from SSW.—NNE. Only in Sangkulirang, where — for reasons that have not yet been sufficiently explained — the direction of the foldings is abnormal i. e. from SW to NE to W—E, also part of the sediments deposited towards the sea were upheaved through the formation of the mountains.

From the fact that in the “normal” coast margin of Kutei terrestrial deposits and in more easterly regions marine deposits of old miocene age are found, we may conclude, that, even if in the old miocene the isles of Borneo and Celebes rose above the level of the sea, they must already have been separated by a sea, so that already in the Old Miocene the Strait of Makassar was extant in design. VERBEEK ¹⁾ has likewise — by other considerations — come to the same conclusions.

We still find an inclination in literature to regard extensive Globigerin marls as being of a pelagian origin. This conclusion would certainly be incorrect for the very thick Globigerinaemarls of Sangkulirang. For in the first place we could observe how very near the coast these sediments have been deposited. In the second place W. STAUB has described a collection of gastropoda from Globigerinaemarls of Godang which contain besides true marine forms also forms of brackish and of fresh water. At last I could state in Globigerinaemarls on the west coast of the isle of Senumpa and in glauconitic Globigerinaemarls in the island of Serai, lying to the East of Senumpa, that they show cross-bedding, a phenomenon that totally excludes their being deposited into deep water,

Buitenzorg, August 1916.

¹⁾ Jaarb. Mijnw. Ned. Indië, 37. 1908. Wetensch. Ged., p 806.

SEKURAU ANTICLINAL (Southern part)	SEKURAU ANTICL. (Eastern part)	SEKURAU ANTICL. (Northern part)	SEMBURU ANTICL.	MALUWI ANTICL. (Northern part)	MALUWI ANTICL. (Southern part)	SAMPAJU ANTICL.	BATU HIDUP ANTICLAL	Gg. BATU ANTICL. (Western limb)	Gg BATU ANTICL. (Eastern limb)
<i>Miocene.</i> Sands, gravel, clays. Coral limestone. Sands, gravel, clays, brown to black coal.	Sands, gravel, clays. Coral limestones and marls with traces of coal.		Sands, gravel, clays Sampajau marls. Limestones, sandy and gravelly Biotite tufas. Globigerina marls, traces of lime-rock and Sampajau marls, finely stratified clayey sands.	Coral limestones Sampajau marls with Globigerinae and Biotite tufas. Globigerina marls.	Sands, gravel, clays. Coral limestone. Biotite tufas. Globigerina marls.	Sands, gravel, clays, brown to dead black coal, in the North traces of Sampajau marls.	Sands, gravels, clays, brown coal (lignite). Sampajau marls, limestones.	Sands, gravels, clays, brown coal (lignite). Sampajau marls, limestones.	Sands, gravels. Sampajau marls, limestone, sands, clays, clayey sands.
<i>Old Miocene,</i> in normal facies coal-bearing.	Shales, sandstones, black glance coal (anthracite), separate strata of coralligene, Lepidocyclus limestone.	Shales, sandstones, separate strata of coralligene, Lepidocyclus limestone.	Shales, sandstones, traces of coal. Limestone banks with Corals and Lepidocyclusinae, finely stratified, clayey sands, traces of Globigerina marls on the upper parts.	Globigerina marls, traces of sand and glance coal (anthracite).	Globigerina marls, traces of sand.	Shales, sandstones, traces of coal and limestone.			
<i>Oldest Miocene, ? Oligocene.</i> (coal-free).	Shales, traces of sandstones and limestones.	Shales, traces of sandstones.							

Physics. — “Some remarks on the theory of monatomic gases”.

By H. A. LORENTZ.

(Communicated in the meeting of September 26, 1914.)

§ 1. Several physicists have recently applied the theory of quanta to gaseous bodies, especially to monatomic gases. The common object of their considerations, much though they differ from each other, may be said to have been the determination of the entropy S of a gas as a function of the volume v and the energy E .

If this function is known, the temperature T and the pressure p may likewise be expressed in terms of E and v by means of the thermodynamic relations

$$\frac{\partial S}{\partial E} = \frac{1}{T}, \quad \frac{\partial S}{\partial v} = \frac{p}{T}.$$

Further the relation between p , v , and T , i.e. the equation of state can be found and also that between v , T , and E , from which we can derive the specific heats.

In the case of an ideal monatomic gas classical thermodynamics lead to the formula

$$S = kN \left(\log v + \frac{3}{2} \log E \right) + a, \dots \dots \dots (1)$$

in which N denotes the number of molecules, k PLANCK'S well known coefficient and a an undeterminate constant. In the way just mentioned we infer from this

$$pv = kNT, \quad E = \frac{3}{2} kNT \dots \dots \dots (2)$$

Now, the new theories differ from classical thermodynamics in so far as they assign to the entropy a completely definite value without an undeterminate constant. As to the way in which v and E occur in the formula, this may either remain as it is in (1) or the form of the connexion may be a more complicated one. In the first case the only change is, that a , which has been called by NERNST “the chemical constant” of the gas, takes a definite value, the equations (2) remaining unmodified. In the second case these latter equations have to be changed.

In the theories in question the entropy is always determined by means of BOLTZMANN'S formula

$$S = k \log W,$$

where W is the “probability” of the state considered. Generally speaking there can be no doubt about the validity of this relation

and it certainly is one of the most important equations of modern physics. Nevertheless, difficulties may arise when we come to consider the rules according to which the value of W must be determined.

§ 2. The state of a gas may be defined by the coordinates of the N molecules and the components of their momenta. These parameters may be regarded as the coordinates of a point in a $6N$ -dimensional space $R_{6,N}$, the "extension-in-phase". The part of this space corresponding to a given value of the volume and to values of the energy between E and $E + dE$, a part which we may call a thin "layer", will have a definite magnitude proportional to dE . Let this value expressed in some properly chosen unit be ΩdE . By putting W proportional to Ω one really finds formula (1) by means of BOLZMANN'S equation.

Indeed, if we take as unit of space in $R_{6,N}$ a cube, the edges of which are parallel to the axes of coordinates and are of the length 1, we have

$$\Omega = \frac{(2\pi Em)^{3/2 N-1} \cdot 2\pi m v^N}{\Gamma\left(\frac{3}{2} N\right)}, \dots \dots \dots (3)$$

where the mass of a molecule is denoted by m .¹⁾

Let us now put $W = C\Omega$, understanding by C a factor that has the same value for all states of the gas. Omitting in the expression for $k \log \Omega$ all terms which do not contain the factor N , as we may do if N is very large²⁾, we find

$$S = kN \left\{ \frac{3}{2} \log(2\pi Em) + \log v - \frac{3}{2} \log\left(\frac{3}{2} N\right) + \frac{3}{2} \right\} + k \log C,$$

which is in agreement with (1), if we put

$$a = \frac{3}{2} kN \left\{ \log(2\pi m) - \log\left(\frac{3}{2} N\right) + 1 \right\} + k \log C.$$

¹⁾ The domain ΩdE in the extension-in-phase may be decomposed into a domain in the extension-in-configuration and one in the extension-in-velocity. The numerical values of these two must be multiplied by each other. The first domain is v^N and for the second we may write $\frac{dK}{dE} dE$, if K is the part of the extension-in-velocity, in which the energy has a value below E . K is a $3N$ dimensional sphere with radius $(2Em)^{1/2}$, so that we have

$$K = \frac{(2\pi Em)^{3/2 N}}{\Gamma\left(\frac{3}{2} N + 1\right)}.$$

²⁾ We may then write $\left(\frac{3N}{2e}\right)^{3/2 N}$ for $\Gamma\left(\frac{3}{2} N\right)$

§ 3. To get an idea of the probability of different states of the gas we can imagine that the state is determined by a lottery in which slips of paper with different numbers are drawn from an urn. This can be arranged in such a way that a slip is drawn for each molecule successively, the number on the slip indicating the place and the state of motion of the molecule. If for each molecule we take the coordinates of the centre and the components of the momentum as the coordinates in a six-dimensional space R_6 , the slip will indicate the point in this extension which represents the position and the state of motion of the molecule or, as we may say, the place of the molecule in R_6 .

Now PLANCK¹⁾ has introduced the fundamental conception of the theory of quanta by imagining that the space R_6 is divided into equal finite elements of a definite magnitude G and that only the question in which of these elements the molecule has to be placed is decided by the lottery. Whether the molecule will lie at one point of the element or at another is not determined in his theory by a consideration of probabilities. Instead of this PLANCK supposes that the molecules lying in the same element of space G are uniformly distributed over its extension. On these suppositions he finds an expression which he considers, not only as *proportional* to the probability but as *equal* to it and which leads to a formula for the entropy containing no indefinite additive constant.

We need not repeat here these calculations of PLANCK. It suffices to remark that the extension-in-phase R_{6N} , which we mentioned in § 2, may be regarded as composed of N extensions-in-phase R_6 each of which belongs to one molecule and that a division of each R_6 into elements of magnitude G involves a division of R_{6N} into elements of magnitude G^N . PLANCK's final result is found if the layer corresponding to dE (§ 2) is expressed in the domain G^N as unity, and if the value of Ω thus found is considered as the numerical value of W .

Instead of (3) we now get

$$\Omega = \frac{(2\pi Em)^{3/2 N-1} \cdot 2 \cdot mv^N}{\Gamma\left(\frac{3}{2} N\right) \cdot G^N} \dots \dots \dots (4)$$

If we substitute this expression for W in BOLTZMANN's formula and again omit all terms not containing N as a factor we find

¹⁾ PLANCK, Vorlesungen über die Theorie der Wärmestrahlung, 2. Aufl. (1913), p. 125; Vorträge über die kinetische Theorie der Materie und der Elektrizität (Wolfskehl-Kongress, 1913), p. 1.

$$S = kN \left\{ \frac{3}{2} \log(2\pi Em) + \log v - \frac{3}{2} \log\left(\frac{3}{2} N\right) + \frac{3}{2} - \log G \right\}. \quad (5)$$

We must remark here that for a definite state of the gas the quantity in brackets is independent of the choice of the fundamental units of length, mass and time and that, therefore, the numerical value of S depends on this choice only in so far as this is the case with k . This becomes evident when we remember that the dimensions of G are $M^3 L^6 T^{-3}$.

PLANCK points out that in all probability G will be connected with the constant h which he has introduced into the theory of radiation and which, when multiplied by the frequency, determines the quantum of energy characteristic of a vibrator. As the dimensions of h are $ML^2 T^{-1}$ the elementary domain G must be proportional to h^3 .

We have finally to make a special supposition about the magnitude of the element G . If we combine n equal quantities of gas simply by putting them side by side, we certainly must assume that the entropy of the whole system will be equal to the sum of the entropies of each of the quantities taken separately. Thus S must be multiplied by n when N , v and E are made n times greater. Now it follows from (5) that this is possible only when G also becomes n times greater, so that the elementary domain must be supposed to be proportional to the number of molecules of the quantity of gas considered.

§.4. It may be objected to PLANCK'S considerations that he has failed to attach a physical meaning to his elementary domain G . As it would have six dimensions its magnitude would have to be determined by certain intervals for the coordinates and the momenta. Now, in so far as we are concerned with the coordinates we can hardly see why we should have to introduce intervals of a fixed finite value into our considerations of probability. To this objection PLANCK replies that we must think of the relative coordinates of one molecule with respect to another and it must be owned indeed that a mutual action between the particles might give us a reason for introducing the finite intervals in question. In this line of thought PLANCK ¹⁾ even tries to account for the proportionality between G and the number of molecules. His reasoning may be reproduced as follows. Let all the molecules except one be already in their places and let $\Delta v_1, \Delta v_2 \dots \Delta v_{N-1}$ be small elements of volume, each in

¹⁾ Vorträge Wolfskehl-Kongress, p. 7 and 8.

the neighbourhood of one of the molecules M_1, M_2, \dots, M_{N-1} , in such a way that Δv_1 has the same position with respect to M_1 as Δv_2 with respect to M_2 etc. Then it might be that the element G with which we are concerned in the case of the N th molecule consists of the volumes $\Delta v_1, \Delta v_2, \dots, \Delta v_{N-1}$ taken together and combined with certain intervals for the momenta; if it were so, G would really be proportional to $N-1$ or to N , as we may say as well.

It must be remarked however that, when we introduced the finite elements G , it was expressly stated that the distribution of the particles over one of them will *not* be determined by probability. Thus, if $\Delta v_1, \Delta v_2, \dots, \Delta v_{N-1}$ must be considered as constituting a single element of volume, the position of the N th molecule either in Δv_1 , or in $\Delta v_2, \Delta v_3$ etc. will not be determined by our lottery. This can hardly be admitted; whether the N th molecule will lie near the first or near any other of the molecules that are already present must certainly be considered as something accidental. Moreover the above reasoning applies only to places in the neighbourhood of one of the $N-1$ molecules, and in gases of small density these places form only a small minority of all those that may be occupied by the N th particle.

§ 5. Before PLANCK, TETRODE ¹⁾ had already calculated the entropy of a gas in a similar way ²⁾. He defines G in terms of the constant h by the relation

$$G = (\omega h)^3,$$

where ω ³⁾ is a numerical coefficient that has to be determined later on. So his elementary domain does not depend on N . But TETRODE divides the expression (4) by $N!$; by this he reaches the same result that PLANCK obtains by putting G proportional to N . Substituting the value found in this way for W in BOLTZMANN'S formula TETRODE finds

$$S = kN \left\{ \frac{3}{2} \log(2\pi Em) + \log v - \frac{3}{2} \log \left(\frac{3}{2} N \right) - \log N + \frac{5}{2} - 3 \log(\omega h) \right\} \quad (6)$$

This expression really fulfills the condition that S shall become n times greater when N , v and E do so. I cannot see however a physical reason for the division of (4) by $N!$

¹⁾ Ann. d. Phys., **38** (1912), p. 434.

²⁾ Similar reasonings have been first published by SACKUR, Ann. d. Phys., **36** (1911), p. 958; **40** (1913), p. 67; Nernst-Festschrift (1912), p. 405.

³⁾ In the notation of TETRODE: z .

§ 6. The hypothesis of quanta has been used in a wholly different way in an other paper by TETRODE¹⁾ and also by LENZ and afterwards by KEESOM²⁾, the method followed in these cases being the same that has been used with much success in the theory of the specific heat of solid bodies. We shall confine ourselves to the considerations of LENZ, which have been communicated by SOMMERFELD³⁾. Let the gas be contained in a vessel having the form of a cube with the edge l . In this system stationary waves of sound of many different kinds can exist. If v is the volume of the cube the number of modes of motion for which the wave-length lies between λ and $\lambda + d\lambda$ is given by

$$\frac{4\pi v}{\lambda^4} d\lambda,$$

the largest value of λ being $2l$.

Now LENZ assumes that the ordinary theory of stationary waves of sound may be applied down to very small values of λ and that we may regard the state of motion of the gas as composed of a great number of such waves with wave-lengths between $2l$ and a certain minimum value, which he calls λ_0 . The latter is chosen in such a manner that the whole number of modes of motion is equal to the number of degrees of freedom of the system of molecules, i.e. to $3N$. This is expressed by the equation

$$\int_{\lambda_0}^{2l} \frac{4\pi v}{\lambda^4} d\lambda = 3N,$$

or

$$\frac{1}{\lambda_0^3} - \frac{1}{8l^3} = \frac{9}{4\pi} \frac{1}{\sigma^3},$$

if we put $\sigma^3 = \frac{v}{N}$, which means that σ is the distance at which, in the case of a cubical arrangement, the particles would lie from each other in the principal directions. If now the vessel contains a very large number of particles so that l is very much greater than σ , the term $\frac{1}{8l^3}$ may be neglected and we find

$$\lambda_0 = 1,12 \sigma.$$

It is further assumed that, for every mode of vibration, we have

¹⁾ Phys. Zeitschr., 14 (1913), p. 212.

²⁾ Proc. Acad. Amsterdam, 16 (1913), p. 227; 17 (1914), p. 20.

³⁾ Vorträge Wolfskehl-Kongress, p. 125.

the following relation between the frequency ν and the wave-length λ

$$\nu = \frac{c}{\lambda},$$

where c , the "velocity of sound", has the same value for all the modes of vibration. LENZ puts

$$c^2 = \frac{\alpha E}{Nm}, \quad \left(\alpha = \frac{10}{9} \right). \quad \dots \quad (7)$$

This relation occurs in the ordinary kinetic theory of a monatomic gas and is maintained by LENZ, although the equations he wants to derive differ from those of the old theory of gases.

In cutting off the "sound spectrum" at the wave-length λ_0 , LENZ follows the example given by DEBYE in his beautiful theory of the specific heat of solid bodies. Just like DEBYE he assumes that the energy is distributed over the different modes of motion in the way required by the theory of quanta, the quantum proper to each mode having the value $h\nu = \frac{hc}{\lambda}$. By probability considerations upon which we need not dwell here the equations for the entropy etc. of the gas are then obtained.

§ 7. In my opinion all this is open to serious objection. In the case of a solid body we can imagine an "original" state in which all molecules are at rest. The different normal modes of vibration which can exist in the body are all deviations from this state and when they all exist at the same time with sufficiently small amplitudes, the total energy — if the energy in the original state is taken to be 0 — is equal to the sum of the energies belonging to the separate modes of motion. The heat motion too may be regarded as made up of all the possible normal vibrations.

The case of a gas is widely different. It is true that here also a wave motion may be regarded as an alternating deviation from an original state, but the latter is not now a state of rest. On the contrary, it is endowed already with the total energy of the molecular motion; in fact it is this latter motion that causes the "elasticity" which serves to maintain the vibrations of sound. It seems rather objectionable to ascribe the energy of the internal motions to a system of vibrations whose laws are deduced on the assumption of a molecular motion that existed already before the vibrations themselves.

It must further be remarked that the ordinary laws of sound motion are true only so long as the wave-length λ is large compared with the mean free path s between two collisions. Only in this case

a gas can be divided into elements of volume (the dimensions of which are small compared with λ and large compared with s) which have a certain individuality, each element dilating or contracting and exerting a pressure on the neighbouring ones, as is admitted in ordinary aerodynamics. Things begin to change already when λ is no longer *very* large compared with s . We must then take account of the phenomena that are caused by the intermixing of adjacent elements of volume. The viscosity and the conduction of heat, the effects of this intermixing, lead to a departure from the simple laws which hold for large wave-lengths. Stationary waves of a length even smaller than s , and yet following more or less the ordinary rules, are entirely out of the question. Indeed under these circumstances the greater part of the molecules that enter a layer of thickness $\frac{1}{2}\lambda$ or $\frac{1}{4}\lambda$ would traverse it without a collision. We cannot say any longer that one layer exerts a pressure on another; on the contrary, the molecular motion will cause a rapid mixing up of the layers.

Now, the smallest wave-length λ_0 introduced by LENZ is not much greater than the distance d of the molecules, while the mean free path s can be a considerable multiple of d . We therefore come to the conclusion that, of the modes of vibration which he considers in his theory, those with a wave-length near the lower limit λ_0 cannot really exist.

SOMMERFELD¹⁾ has tried to meet this objection by observing that neither at somewhat high temperatures, nor at very low ones we need fear considerable errors in LENZ's formulae. For high temperatures they agree with those which may be derived from the ordinary theory of gases and LENZ's equations show that at low temperatures the energy becomes more and more concentrated in the modes of vibration of large wave-length to which our objection does not apply. This is so indeed, but a simple calculation shows that it is not until the temperature is extremely low, that the greater part of the energy will have shifted to waves considerably longer than λ_0 .

According to LENZ's theory the energy belonging to the modes of vibration with wave-lengths between λ and $\lambda + d\lambda$ is given by

$$4\pi h\nu \cdot \frac{1}{\frac{2hc}{e^{k\lambda T} - 1}} \cdot \frac{d\lambda}{\lambda^5}.$$

We shall use this expression to seek a certain mean wave-length λ' which we define by the condition that the energy corresponding

¹⁾ L.c., p. 141, 142.

to the motions with wave-lengths beneath λ' has the same magnitude as that belonging to wave-lengths beyond λ' . This is expressed by the equation

$$\int_{\lambda'}^{\infty} \frac{1}{\frac{2hc}{\rho k T} - 1} \cdot \frac{d\lambda}{\lambda^5} = \frac{1}{2} \int_{\lambda_0}^{\infty} \frac{1}{\frac{2hc}{\rho k T} - 1} \cdot \frac{d\lambda}{\lambda^5},$$

or if we put

$$\frac{2hc}{k\lambda T} = x, \quad \frac{2hc}{k\lambda_0 T} = x_0 \text{ and } \frac{2hc}{k\lambda' T} = x' \dots \dots \dots (8)$$

by

$$\int_0^{x'} \frac{x^3 dx}{e^x - 1} = \frac{1}{2} \int_0^{x_0} \frac{x^3 dx}{e^x - 1} \dots \dots \dots (9)$$

From this equation we can derive by suitable approximations for each x_0 the corresponding x' . If now we consider a gas of definite density, ρ and therefore λ_0 are given and we can determine the value of x_0 for each temperature T . It is true that the second of the equations (8) does not suffice for this, as c depends, in the way indicated by (7), on E , which is a complicated function of T . But LENZ gives the formula

$$x_0^5 = \frac{\Theta}{T} \int_0^{x_0} \frac{x^3 dx}{e^x - 1} \dots \dots \dots (10)$$

which can be used to determine x_0 . The quantity

$$\Theta = \frac{18\alpha h^2}{m k \lambda_0^3} \dots \dots \dots (11)$$

is a certain temperature which can be indicated for each gas as soon as its density is given. After having chosen T , we find x_0 from (10), x' from (9) and finally λ' from the relation

$$\lambda' = \frac{x_0}{x'} \lambda_0 \dots \dots \dots (12)$$

following from (8).

Let us consider as an example helium of the density corresponding to 0° C. and 1 atm. Then $\Theta = 7^\circ$ and according to (10) $x_0 = 1$, if $\frac{T}{\Theta} = 0,22$; for we have

$$\int_0^1 \frac{x^3 dx}{e^x - 1} = 0,22.$$

From (9) we find approximately $w' = 0,75$, so that (12) gives

$$\lambda' = \frac{4}{3} \lambda_0.$$

So we see that at the temperature $T = 0,22 \Theta = 1^\circ,5$, which is very low indeed, still half of the energy belongs to modes of motion with wave-lengths below $\frac{4}{3} \lambda_0$, i.e. below $1,5\theta$ and therefore far below the mean free path s .

§ 8. According to the theory of LENZ the entropy of a gas does not depend on E and v in the way expressed by (1); the equation of state and the formulae for the specific heats become different from those in the ordinary theory of gases. For temperatures high compared with Θ however we are led back to the form (1). For then we find from LENZ's formulae

$$E = \frac{3}{2} kNT \left(1 - \frac{1}{8} \sqrt{\frac{3\Theta}{T}} \right),$$

$$S = 3kN \left(\frac{4}{3} - \frac{1}{2} \log \frac{\Theta}{3T} \right), \quad \dots \dots \dots (13)$$

and after some reductions

$$S = kN \left\{ \frac{3}{2} \log (2 \pi Em) + \log v - \frac{3}{2} \log \left(\frac{3}{2} N \right) - \log N \right. \\ \left. - \frac{1}{2} \log (12000 \pi) + 4 - 3 \log h \right\},$$

This agrees with the formula of TETRODE [(6) above] if we put $\omega = 3,5$.

It must, however, be remarked that, even if one leaves aside the first of the objections mentioned in § 7, one cannot expect a somewhat exact determination of the chemical constant. Equation (13) shows that this constant is connected with $\log \Theta$ and therefore on account of (11) with $\log \lambda_0$, λ_0 being the minimum wave-length, and we have seen already that the part of the theory relating to the smaller wave-lengths is the most contestable one.

§ 9. TETRODE has determined the chemical constant for the monatomic vapour of mercury, a substance whose properties are well known, or rather he has derived the coefficient ω of equation (6) from the results of observation. He found¹⁾

$$\omega = 1,05.$$

Following the same course of thought and using the same data

¹⁾ Ann. d. Phys., **39** (1912), p. 255.

I have repeated this determination in the following somewhat different way. I shall consider a gram molecule, so that N becomes AVOGADRO'S constant and kN the gas constant R .

Let, at the temperature T , p be the vapour pressure of fluid mercury, S the entropy of the vapour, S' that of the fluid, v the volume of the vapour and v' that of the fluid. Then we have according to a well known thermodynamic relation

$$S - S' = (v - v') \frac{dp}{dT},$$

for which we may write

$$S - S' = v \frac{dp}{dT},$$

as v is much greater than v' .

If the vapour pressure is very low we may treat the vapour as an ideal gas, so that

$$v = \frac{RT}{p} \dots \dots \dots (14)$$

and

$$S - S' = RT \frac{d \log p}{dT} \dots \dots \dots (15)$$

If now in (6) we substitute R for kN , (14) for v , $\frac{M}{N}$ for m , M being the molecular weight, and $\frac{3}{2} RT$ for E , we get

$$S = R \left\{ \frac{5}{2} \log(RT) - \log p - 4 \log N + \frac{3}{2} \log(2\pi M) + \frac{5}{2} - 3 \log(\omega h) \right\}.$$

By substituting this in (15) we find

$$3 \log \omega = -\frac{S'}{R} - \frac{d}{dT} (T \log p) + A, \dots \dots \dots (16)$$

where for shortness' sake I have put

$$A = \frac{5}{2} \log(RT) - 4 \log N + \frac{3}{2} \log(2\pi M) + \frac{5}{2} - 3 \log h \dots (17)$$

This quantity is completely known. Thus we can calculate the coefficient ω as soon as we know p as a function of T and besides the entropy S' of the fluid.

§ 10. For the pressure we may use HERTZ'S formula¹⁾

$$\log p = a - \beta \log T - \frac{\gamma}{T}$$

¹⁾ H. HERTZ, Ann. d. Phys., 17 (1882), p. 193.

with ¹⁾ $\alpha = 31,583$; $\beta = 0,847$; $\gamma = 7697$, from which we draw

$$\frac{d}{dT} (T \log p) = (\alpha - \beta) - \beta \log T. \quad (18)$$

To be able to determine S' too, we shall take for T the melting point of mercury (234°). If r is the heat of fusion and S'' the entropy of solid mercury we have

$$S' = S'' + \frac{r}{T}. \quad (19)$$

We must remark here that strictly speaking this formula gives the value of S' for a pressure of 1 atm. (if we consider the equilibrium between solid and fluid mercury under that pressure), while in the preceding equations S' denotes the entropy of the fluid under the pressure of its vapour. It is easily seen that we may neglect this difference.

It remains to determine the entropy S'' of solid mercury. This can be found by supposing, as is often done in connection with NERNST's heat theorem, that this entropy is 0 at the absolute zero. Then it can be calculated for any other temperature by means of the specific heat c_p of solid mercury. We have

$$S'' = \int_0^T \frac{c_p}{T} dT, \quad (20)$$

if we assume the pressure to be 1 atm. during the heating from 0° to T° .

NERNST ²⁾ has given a formula for the specific heat of a gram molecule, based on POLLITZER's measurements and by means of which we find ³⁾

¹⁾ According to HERTZ we have, using Briggian logarithms and expressing the vapour pressure in millimetres of mercury

$$\log p = 10,59271 - 0,847 \log T - \frac{3342}{T}.$$

If we want to know the pressure in dynes per cm^2 , we must add $\log 1330$, as a pressure of 1 mm. of mercury corresponds to 1330 dynes per cm^2 . To pass finally to Neperian logarithms we must divide the first and the third term by $\log_{10} e$.

²⁾ Ann. d. Phys., **36** (1911), p. 431.

³⁾ According to NERNST we have in C.G.S. units

$$c_v = \frac{3}{2} R [\varphi(\sigma) + \varphi(\frac{1}{2}\sigma)],$$

where the function φ is determined by

$$S'' = 6,95 R.$$

Now the heat of fusion per gram molecule is 554,5 cal. so that
 $r = 279 R$,

$$\frac{r}{T} = 1,19 R$$

and, according to (19),

$$S' = 8,14 R.$$

From (18) follows

$$\frac{d}{dT} (T \log p) = 26,12$$

and from (17)¹⁾

$$A = 33,92.$$

Substituting these different values in (16) we find

$$\omega = 0,7.$$

§ 11. As to the degree of precision of this result it must be remarked in the first place that, according to (16) and (17), ω is proportional to low powers of RT , n and h . Therefore, an uncertainty in the values of these quantities will not cause an error of many percentages in ω .

$$\varphi(x) = \frac{\left(\frac{x}{T}\right)^2 \frac{x}{e^T}}{\left(\frac{x}{e^T} - 1\right)^2}.$$

For mercury σ must be put equal to 97. Further

$$c_p = c_v + fT^{3/2}.$$

For the coefficient f NERNST gives $21 \cdot 10^{-5}$, but here a calory is taken as unit of heat Choosing the erg instead and substituting gR for f , so that

$$c_p = c_v + RgT^{3/2}$$

we have

$$g = 10,6 \cdot 10^{-5}$$

From (20) we now find

$$S'' = \frac{3}{2} R [\chi(\sigma) + \chi(\frac{1}{2}\sigma)] + \frac{2}{3} RgT^{3/2}.$$

if we put

$$\chi(x) = \frac{\frac{x}{T} \cdot e^{\frac{x}{T}}}{e^{\frac{x}{T}} - 1} - \log \left(\frac{x}{e^{\frac{x}{T}}} - 1 \right).$$

1) Calculated with: $R = 83,2 \cdot 10^6$; $N = 67 \cdot 10^{23}$; $M = 200$; $h = 6,42 \cdot 10^{-27}$.

On the contrary the value substituted for $\frac{S'}{R}$ may be in error to a considerable extent. A change of a full unit however in this value (one eighth of the amount) produces a change in ω of about 14% only. So we may perhaps conclude that the value of ω will not differ much from 1 and that the values found for the vapour pressure of mercury agree in a rather satisfactory way with the theory of TETRODE, if we give the elementary domain G the value h^3 ¹⁾.

Nevertheless, in my opinion, we may not attach much value to this result. Besides the difficulties which we pointed out already there is still another serious objection.

Formula (15) connects the vapour pressure with the entropy-difference between gaseous and fluid mercury or, when we take into account the relation (19), with the difference between gaseous and solid mercury. Now we must doubt seriously whether this difference can be rightly evaluated if the undeterminate constants in S and S'' are fixed in the above mentioned rather arbitrary way. On the ground of BOLTZMANN'S formula we may account for the entropy S'' , viz. for the change which the entropy of solid mercury undergoes when heated from 0° to T° ; to this effect we have to compare the probabilities of different states of the solid mercury. This is done e.g. by DEBYE in his theory of specific heats. In this comparison we are concerned only with quantities referring to the solid state, e.g. the modulus of elasticity. In the deduction of (6), on the other hand, only the gaseous state has been considered. The question arises whether it will be possible, by a combination of these results, to determine the difference $S-S''$, which according

¹⁾ The objection might be raised that in the above calculation HERTZ'S formula for the vapour pressure has been applied for a temperature at which this pressure has never been measured. In reality however the value of ω given by (16), (17) and (18) is independent of the choice of the temperature.

Indeed, the differential coefficient of the right hand side of (16) with respect to T is

$$-\frac{1}{R} \frac{dS'}{dT} - \frac{d^2}{dT^2} (T \log p) + \frac{5}{2T}$$

$\left(T \frac{dS'}{dT} \right.$ is the specific heat of the fluid under its vapour pressure). According to a well known thermodynamic theorem this quantity must be zero. In virtue of (18) it becomes

$$-\frac{1}{R} \frac{dS'}{dT} + \frac{\beta}{T} + \frac{5}{2T}$$

and this expression really is zero because HERTZ has chosen the coefficient β in accordance with the theorem in question.

to BOLTZMANN'S theorem is connected with the probability that, in a system consisting of a solid and a gaseous phase, a greater or a smaller part belongs to the latter. The circumstance that, in considering this latter probability, we must attend to the difference in potential energy of the two phases cannot but increase our doubt, for neither in the determination of S'' nor in the determination of S in the above mentioned way we have had to speak of this difference. If, as we should expect, the difference $S-S''$ depended to a considerable extent on the relative values of the potential energy, we might still put the entropy $S''=0$ for $T=0$, but it would no longer be possible to determine the constant a which occurs in formula (1) for the gaseous state by considering only the phenomena in the gas, as is done in the theories discussed here. We ought rather to derive it from an examination of the equilibrium between the two phases.

I think we may conclude from what precedes that, though the value found for ω , if it be not quite accidental, pleads in favour of the application of the theory of quanta to the problem of vaporisation, yet the way in which this application has been made requires further explanation and justification.

Physics. — “On HAMILTON'S principle in EINSTEIN'S theory of gravitation”. By H. A. LORENTZ.

(Communicated in the meeting of January 30, 1915).

The discussion of some parts of EINSTEIN'S theory of gravitation¹⁾ may perhaps gain in simplicity and clearness, if we base it on a principle similar to that of HAMILTON, so much so indeed that HAMILTON'S name may properly be connected with it. Now that we are in possession of EINSTEIN'S theory we can easily find how this variation principle must be formulated for systems of different nature and also for the gravitation field itself.

Motion of a material point.

§ 1. Let a material point move under the influence of a force with the components K_1, K_2, K_3 . Let us vary every position x, y, z

¹⁾ EINSTEIN u. GROSSMANN, Entwurf einer verallgemeinerten Relativitätstheorie und einer Theorie der Gravitation. Zeitschr. f. Math. u. Phys. 62, (1914), p. 225.

EINSTEIN, Die formale Grundlage der allgemeinen Relativitätstheorie, Sitz. Ber. Akad. Berlin, 1914, p. 1030.

occurring in the real motion in the way defined by the infinitely small quantities $\delta x, \delta y, \delta z$. If, in the varied motion, the position $x + \delta x, y + \delta y, z + \delta z$ is reached at the same time t as the position x, y, z in the real motion, we shall have the equation

$$\delta \int L dt + \int (K_1 \delta x + K_2 \delta y + K_3 \delta z) dt = 0, \quad \dots \quad (1)$$

L being the Lagrangian function and the integrals being taken over an arbitrary interval of time, at the beginning and the end of which the variations of the coordinates are zero. K is supposed to be a force acting on the material point beside the forces that are included in the Lagrangian function.

§ 2. We may also suppose the time t to be varied, so that in the varied motion the position $x + \delta x, y + \delta y, z + \delta z$ is reached at the time $t + \delta t$. In the first term of (1) this does not make any difference, if we suppose that for the extreme positions also $\delta t = 0$. As to the second term we remark that the coordinates in the varied motion at the time t may now be taken to be $x + \delta x - v_1 \delta t, y + \delta y - v_2 \delta t, z + \delta z - v_3 \delta t$, if v_1, v_2, v_3 are the velocities in the real motion. In the second term we must therefore replace $\delta x, \delta y, \delta z$ by $\delta x - v_1 \delta t, \delta y - v_2 \delta t, \delta z - v_3 \delta t$. In the equation thus found we shall write w_1, w_2, w_3, w_4 for x, y, z, t . For the sake of uniformity we shall add to the three velocity components a fourth, which, however, necessarily must have the value 1 as we take for it $\frac{dx_4}{dx_4}$. We shall also add to the three components of the force K a fourth component, which we define as

$$K_4 = -(v_1 K_1 + v_2 K_2 + v_3 K_3), \quad \dots \quad (2)$$

and which therefore represents the work of the force per unit of time with the negative sign.

Then we have instead of (1)

$$\delta \int L dt + \int \sum (a) K_a \delta x_a \cdot dt = 0, \quad \dots \quad (3)$$

and for (2) we may write ¹⁾

¹⁾ In these formulae we have put between parentheses behind the sign of summation the index with respect to which the summation must be effected, which means that the values 1, 2, 3, 4 have to be given to it successively. In the same way two or more indices behind the sign of summation will indicate that in the expression under this sign these values have to be given to each of the indices. $\Sigma(ab)$ f. i. means that each of the four values of a has to be combined with each of the four values of b .

$$\sum (a) v_a K_a = 0 \dots \dots \dots (4)$$

§ 3. In EINSTEIN'S theory the gravitation field is determined by certain characteristic quantities g_{ab} , functions of x_1, x_2, x_3, x_4 , among which there are 10 different ones, as

$$g_{ba} = g_{ab} \dots \dots \dots (5)$$

A point of fundamental importance is the connection between these quantities and the corresponding coefficients g'_{ab} , with which we are concerned, when by an arbitrary substitution x_1, \dots, x_4 are changed for other coordinates x'_1, \dots, x'_4 . This connection is defined by the condition that

$$ds^2 = g_{11} dx_1^2 + \dots + g_{44} dx_4^2 + 2g_{12} dx_1 dx_2 + \dots$$

or shorter

$$ds^2 = \sum(ab) g_{ab} dx_a dx_b$$

be an invariant.

Putting

$$dx_a = \sum(b) p_{ab} dx'_b \dots \dots \dots (6)$$

we find

$$g'_{ab} = \sum(cd) p_{ca} p_{db} g_{cd} \dots \dots \dots (7)$$

Instead of (6) we shall also write

$$dx'_a = \sum(b) \pi_{ba} dx_b,$$

so that the set of quantities π_{ba} may be called the inverse of the set p_{ab} . Similarly, we introduce a set of quantities γ_{ba} , the inverse of the set g_{ab} .¹⁾

We remark here that in virtue of (5) and (7) $g'_{ba} = g'_{ab}$ and that likewise $\gamma_{ba} = \gamma_{ab}$.

Our formulae will also contain the determinant of the quantities g_{ab} , which we shall denote by g , and the determinant p of the coefficients p_{ab} (absolute value: $|p|$). The determinant g is always negative.

We may now, as has been shown by EINSTEIN, deduce the motion of a material point in a gravitation field from the principle expressed by (3) if we take for the Lagrangian function

$$L = -m \frac{ds}{dt} = -m \sqrt{\sum(ab) g_{ab} v_a v_b} \dots \dots \dots (8)$$

¹⁾ Suppose

$$x_a = \sum(b) v_{ba} \xi_b$$

to follow from the equations

$$\xi_a = \sum(b) n_{ab} v_b;$$

then the set v_{ab} is the inverse of the set n_{ab} .

Motion of a system of incoherent material points.

§ 4. Let us now, following EINSTEIN, consider a very large number of material points wholly free from each other, which are moving in a gravitation field in such a way that at a definite moment the velocity components of these points are continuous functions of the coordinates. By taking the number very large we may pass to the limiting case of a continuously distributed matter without internal forces.

Evidently the laws of motion for a system of this kind follow immediately from those for a single material point. If ρ is the density and $dx dy dz$ an element of volume, we may write instead of (8)

$$-\rho \sqrt{\sum(ab) g_{ab} v_a v_b} \cdot dx dy dz. \quad (9)$$

If now we wish to extend equation (3) to the whole system we must multiply (9) by dt and integrate with respect to x, y, z and t .

In the last term of (3) we shall do so likewise after having replaced the components K_a by $K_a dx dy dz$, so that in what follows K will represent the external force per unit of volume.

If further we replace $dx dy dz dt$ by dS , an element of the four-dimensional extension x_1, \dots, x_4 , and put

$$\rho v_a = w_a, \quad (10)$$

$$L = -\sqrt{\sum(ab) g_{ab} w_a w_b} \quad (11)$$

we find the following form of the fundamental theorem.

Let a variation of the motion of the system of material points be defined by the infinitely small quantities δx_a , which are arbitrary continuous functions of the coordinates within an arbitrarily chosen finite space S , at the limits of which they vanish. Then we have, if the integrals are taken over the space S , and the quantities g_{ab} are left *unchanged*,

$$\delta \int L dS + \int \sum(a) K_a \delta x_a \cdot dS = 0 \quad (12)$$

For the first term we may write

$$\int \delta L \cdot dS,$$

if δL denotes the change of L at a fixed point of the space S .

The quantity $L dS$ and therefore also the integral $\int L dS$ is invariant when we pass to another system of coordinates.¹⁾

¹⁾ This follows from the invariancy of ds^2 , combined with the relations

$$\frac{\partial'}{\partial x'_4} = |p| \frac{\partial}{\partial x_4}, \quad dS' = \frac{1}{|p|} dS.$$

§ 5. The equations of motion may be derived from (12) in the following way. When the variations δx_a have been chosen, the varied motion of the matter is perfectly defined, so that the changes of the density and of the velocity components are also known. For the variations at a fixed point of the space S we find

$$\delta w_a = \Sigma(b) \frac{\partial \chi_{ab}}{\partial x_b} \dots \dots \dots (13)$$

where

$$\chi_{ab} = w_b \delta x_a - w_a \delta x_b \dots \dots \dots (14)$$

(Therefore: $\chi_{ba} = -\chi_{ab}$, $\chi_{aa} = 0$).

If for shortness we put

$$P = \sqrt{\Sigma(ab)g_{ab}w_a w_b} \dots \dots \dots (15)$$

so that $L = -P$, and

$$\Sigma(b)g_{ab}w_b = u_a, \dots \dots \dots (16)$$

we have

$$\begin{aligned} dL &= -\Sigma(a) \frac{u_a}{P} \delta w_a = -\Sigma(ab) \frac{u_a}{P} \frac{\partial \chi_{ab}}{\partial x_b} = \\ &= -\Sigma(ab) \frac{\partial}{\partial x_b} \left(\frac{u_a}{P} \chi_{ab} \right) + \Sigma(ab) \chi_{ab} \frac{\partial}{\partial x_b} \left(\frac{u_a}{P} \right), \end{aligned}$$

so that, with regard to (14),

$$\left. \begin{aligned} dL + \Sigma(a)K_a \delta x_a &= -\Sigma(ab) \frac{\partial}{\partial x_b} \left(\frac{u_a}{P} \chi_{ab} \right) + \\ &+ \Sigma(ab)(w_b \delta x_a - w_a \delta x_b) \frac{\partial}{\partial x_b} \left(\frac{u_a}{P} \right) + \Sigma(a)K_a \delta x_a \end{aligned} \right\} \dots \dots (17)$$

If after multiplication by dS this expression is integrated over the space S the first term on the right hand side vanishes, χ_{ab} being 0 at the limits. In the last two terms only the variations δx_a occur, but not their differential coefficients, so that according to our fundamental theorem, when these terms are taken together, the coefficient of each δx_a must vanish. This gives the equations of motion¹⁾

$$K_a = \Sigma(b)w_b \left[\frac{\partial}{\partial x_a} \left(\frac{u_b}{P} \right) - \frac{\partial}{\partial x_b} \left(\frac{u_a}{P} \right) \right], \dots \dots (18)$$

which evidently agree with (4), or what comes to the same, with

$$\Sigma(a)w_a K_a = 0 \dots \dots \dots (19)$$

In virtue of (18) the general equation (17), which holds for

¹⁾ In the term

$$-\Sigma(ab)w_a \delta x_b \frac{\partial}{\partial x_b} \left(\frac{u_a}{P} \right)$$

the indices a and b must first be interchanged.

arbitrary variations that need not vanish at the limits of S , becomes

$$\delta L + \Sigma(a)K_a \delta w_a = - \Sigma(ab) \frac{\partial}{\partial x_b} \left(\frac{u_a}{P} \chi_{ab} \right) \dots (20)$$

§ 6. We can derive from this the equations for the momenta and the energy.

Let us suppose that only one of the four variations δx_a differs from 0 and let this one, say δx_c , have a constant value. Then (14) shows that for each value of a that is not equal to c

$$\chi_{ac} = -w_a \delta w_c, \quad \chi_{ca} = w_a \delta w_c, \dots (21)$$

while all χ 's without an index c vanish.

Putting first $b=c$ and then $a=c$, and replacing at the same time in the latter case b by a , we find for the right hand side of (20)

$$\Sigma(a) \frac{\partial}{\partial x_c} \left(\frac{u_a w_a}{P} \right) \delta w_c - \Sigma(a) \frac{\partial}{\partial x_a} \left(\frac{u_c w_a}{P} \right) \delta x_c \dots$$

But, according to (15) and (16),

$$\Sigma(a) \frac{u_a w_a}{P} = P = -L,$$

so that (20) becomes

$$\delta L + K_c \delta x_c = - \frac{\partial L}{\partial x_c} \delta x_c - \Sigma(a) \frac{\partial}{\partial x_a} \left(\frac{u_c w_a}{P} \right) \delta x_c \dots (22)$$

It remains to find the value of δL .

The material system together with its state of motion has been shifted in the direction of the coordinate x_c over a distance δx_c . If the gravitation field had participated in this shift, δL would have been equal to $-\frac{\partial L}{\partial x_c} \delta x_c$. As, however, the gravitation field has been

left unchanged, $\frac{\partial L}{\partial x_c}$ in this last expression must be diminished by

$\left(\frac{\partial L}{\partial x_c} \right)_w$, the index w meaning that we must keep constant the quantities w_a and consider only the variability of the coefficients g_{ab} . Hence

$$\delta L = \left\{ - \frac{\partial L}{\partial x_c} + \left(\frac{\partial L}{\partial x_c} \right)_w \right\} \delta x_c.$$

Substituting this in (22) and putting

¹⁾ The circumstance that (21) does not hold for $a=c$ might lead us to exclude this value from the two sums. We need not, however, introduce this restriction, as the two terms that are now written down too much, annul each other.

$$\frac{u_c w_a}{P} = T_{ac}, \dots \dots \dots (23)$$

we find

$$K_c + \left(\frac{\partial L}{\partial x_c}\right)'_w = - \Sigma (a) \frac{\partial T_{ac}}{\partial x_a} \dots \dots \dots (24)$$

The first three of these equations ($c = 1, 2, 3$) refer to the momenta; the fourth ($c = 4$) is the equation of energy. As we know already the meaning of K_1, \dots, K_4 we can easily see that of the other quantities. The stresses $X_x, X_y, X_z, Y_x \dots$ are $T_{11}, T_{21}, T_{31}, T_{12} \dots$; the components of the momentum per unit of volume $-T_{41}, -T_{42}, -T_{43}$; the components of the flow of energy, T_{14}, T_{24}, T_{34} . Further T_{44} is the energy per unit of volume. The quantities

$$\left(\frac{\partial L}{\partial x_1}\right)'_w, \left(\frac{\partial L}{\partial x_2}\right)'_w, \left(\frac{\partial L}{\partial x_3}\right)'_w$$

are the momenta which the gravitation field imparts to the material system per unit of time and unit of volume, while the energy which the system draws from that field is given by $-\left(\frac{\partial L}{\partial x_4}\right)'_w$.

An electromagnetic system in the gravitation field.

§ 7. We shall now consider charges moving under the influence of external forces in a gravitation field; we shall determine the motion of these charges and the electromagnetic field belonging to them. The density ρ of the charge will be supposed to be a continuous function of the coordinates; the force per unit of volume will be denoted by K and the velocity of the point of a charge by v . Further we shall again introduce the notation (10).

In EINSTEIN'S theory the electromagnetic field is determined by two sets, each of four equations, corresponding to well known equations in the theory of electrons. We shall consider one of these sets as the mathematical description of the system to which we have to apply HAMILTON'S principle; the second set will be found by means of this application.

The first set, the fundamental equations, may be written in the form

$$\Sigma (b) \frac{\partial \psi_{ab}}{\partial x_b} = w_a, \dots \dots \dots (25)$$

the quantities ψ_{ab} ¹⁾ on the left hand side being subject to the conditions

$$\psi_{aa} = 0, \quad \psi_{ba} = -\psi_{ab}, \quad (26)$$

so that they represent 6 mutually independent numerical values. These are the components of the electric force \mathbf{E} and the magnetic force \mathbf{H} . We have indeed

$$\left. \begin{aligned} \psi_{41} = E_x, \quad \psi_{42} = E_y, \quad \psi_{43} = E_z, \\ \psi_{23} = H_x, \quad \psi_{31} = H_y, \quad \psi_{12} = H_z, \end{aligned} \right\} (27)$$

and it is thus seen that the first three of the formulae (25) express the connection between the magnetic field and the electric current. The fourth shows how the electric field is connected with the charge.

On passing to another system of coordinates we have for w_a the transformation formula

$$w'_a = |p| \sum (b) \pi_{ba} w_b,$$

which can easily be deduced, while for ψ_{ab} we shall assume the formula

$$\psi'_{ab} = |p| \sum (cd) \tau_{ca} \pi_{db} \psi_{cd} (28)$$

In virtue of this assumption the equations (25) are covariant for any change of coordinates.

§ 8. Beside ψ_{ab} we shall introduce certain other quantities $\bar{\psi}_{ab}$ which we define by

$$\bar{\psi}_{ab} = \frac{1}{\sqrt{-g}} \sum (cd) g_{ca} g_{db} \psi_{cd} (29)$$

or with regard to (26)

$$\bar{\psi}_{ab} = \frac{1}{\sqrt{-g}} \sum (\bar{cd}) (g_{ca} g_{db} - g_{da} g_{cb}) \psi_{cd}, (30)$$

in which last equation the bar over cd means that in the sum each combination of two numbers occurs only once.

As a consequence of this definition we have

$$\bar{\psi}_{aa} = 0, \quad \bar{\psi}_{ba} = -\bar{\psi}_{ab}, \quad (31)$$

and we find by inversion ²⁾

$$\psi_{ab} = \sqrt{-g} \sum (cd) \gamma_{ac} \gamma_{bd} \bar{\psi}_{cd} (32)$$

¹⁾ The quantities ψ_{ab} are connected with the components φ_{ab} of the tensor introduced by EINSTEIN by the equations $\psi_{ab} = \sqrt{-g} \cdot \varphi_{ab}$.

²⁾ By the definition of the quantities γ (§ 3) we have

$$\sum (a) g_{ab} \gamma_{ab} = 1 (\alpha)$$

and for $b = c$

$$\sum (a) g_{ab} \gamma_{ac} = 0, \quad \text{or} \quad \sum (a) g_{ba} \gamma_{ca} = 0. (\beta)$$

Substituting for $\bar{\psi}_{cd}$ an expression similar to (29) with other letters as indices,

To these equations we add the transformation formula for $\bar{\psi}_{ab}$, which may be derived from (28) ¹⁾

$$\bar{\psi}'_{ab} = \sum (cd) p_{ca} p_{db} \bar{\psi}_{cd} \dots \dots \dots (33)$$

§ 9. We shall now consider the 6 quantities (27) which we shall especially call "the quantities ψ " and the corresponding quantities $\bar{\psi}$, viz. $\bar{\psi}_{41} \dots \bar{\psi}_{12}$.

According to (30) these latter are homogeneous and linear functions of the former and as (because of (5)) the coefficient of ψ_{cd} in $\bar{\psi}_{ab}$ is equal to the coefficient of ψ_{ab} in $\bar{\psi}_{cd}$, there exists a homogeneous quadratic function L of $\psi_{41}, \dots, \psi_{12}$, which, when differentiated with respect to these quantities, gives $\bar{\psi}_{41}, \dots, \bar{\psi}_{12}$. Therefore

$$\frac{\partial L}{\partial \psi_{ab}} = \bar{\psi}_{ab} \dots \dots \dots (34)$$

and

$$L = \frac{1}{2} \sum (\bar{ab}) \psi_{ab} \bar{\psi}_{ab} \dots \dots \dots (35)$$

If, as in (34), we have to consider derivatives of L, this quantity will be regarded as a quadratic function of the quantities ψ .

The quantity L can now play the same part as the quantity that is represented by the same letter in §§ 4—6. Again LdS is invariant when the coordinates are changed. ²⁾

we have

$$\sqrt{-g} \sum (cd) \gamma_{ac} \gamma_{bd} \bar{\psi}_{cd} = \sum (cdef) \gamma_{ac} \gamma_{bd} g_{ec} g_{fd} \psi_{ef} = \sum (df) \gamma_{bd} g_{fd} \psi_{af} = \psi_{ab}$$

The last two steps of this transformation, which rest on (α) and (β), will need no further explanation. In a similar way we may proceed (comp. the following notes) in many other cases, using also the relations $\sum (a) p_{ba} \pi_{ba} = 1$ and $\sum (a) p_{ba} \pi_{ca} = 0$ (the latter for $b \neq c$), which are similar to (α) and (β).

¹⁾ If we start from the equation for $\bar{\psi}'_{ab}$ that corresponds to (29) and if we use (7) and (28), attending to $\sqrt{-g'} = |p| \sqrt{-g}$, we find

$$\begin{aligned} \bar{\psi}'_{ab} &= \frac{1}{\sqrt{-g'}} \sum (cd) g'_{ca} g'_{db} \psi'_{cd} = \\ &= \frac{1}{\sqrt{-g}} \sum (c d e f h i j k) p_{ec} p_{fa} p_{hd} p_{ib} \pi_{jc} \pi_{kd} g_{ef} g_{hi} \psi_{jk} \end{aligned}$$

This may be transformed in two steps (comp. the preceding note) ²⁾ to

$$\frac{1}{\sqrt{-g}} \sum (e f h i) p_{fa} p_{ib} g_{ef} g_{hi} \psi_{eh}$$

In this way we may proceed further, after first expressing ψ_{eh} as a function of $\bar{\psi}_{lm}$ by means of (32).

²⁾ Instead of (35) we may write $L = \frac{1}{4} \sum (ab) \psi_{ab} \bar{\psi}_{ab}$ and now we have according to (28) and (33)

§ 10. We shall define a varied motion of the electric charges by the quantities δx_a and we shall also vary the quantities ψ_{ab} , so far as can be done without violating the connections (25) and (26). The possible variations $\delta\psi_{ab}$ may be expressed in δx_a and four other infinitesimal quantities q_a which we shall presently introduce. Our condition will be that equation (12) shall be true if, leaving the gravitation field unchanged, we take for δx_a and q_a any continuous functions of the coordinates which vanish at the limits of the domain of integration. We shall understand by δw_a , $\delta\psi_{ab}$, δL the variations at a fixed point of this space. The variations δw_a are again determined by (13) and (14), and we have, in virtue of (26) and (25);

$$\delta\psi_{aa} = 0, \delta\psi_{ba} = -\delta\psi_{ab}, \Sigma(b) \frac{\partial\delta\psi_{ab}}{\partial x_b} = \delta w_a = \Sigma(b) \frac{\partial\chi_{ab}}{\partial x_b}.$$

If therefore we put

$$\delta\psi_{ab} = \chi_{ab} + \mathfrak{D}_{ab}, \dots \dots \dots (36)$$

we must have

$$\mathfrak{D}_{aa} = 0, \mathfrak{D}_{ba} = -\mathfrak{D}_{ab}, \Sigma(b) \frac{\partial\mathfrak{D}_{ab}}{\partial x_b} = 0.$$

It can be shown that quantities \mathfrak{D}_{ab} satisfying these conditions may be expressed in terms of four quantities q_a by means of the formulae

$$\mathfrak{D}_{ab} = \frac{\partial q_{b'}}{\partial x_a} - \frac{\partial q_{a'}}{\partial x_{b'}} \quad (a \neq b). \dots \dots \dots (37)$$

Here a' and b' are the numbers that remain when of 1, 2, 3, 4 we omit a and b , the choice of the value of a' and that of b' being such that the order a, b', a', b' can be derived from the order 1, 2, 3, 4 by an even number of permutations each of two numbers.

§ 11. By (34), (36) and (37) we have

$$\begin{aligned} \delta L + \Sigma(a) K_a \delta x_a &= \Sigma(\overline{ab}) \overline{\psi}_{ab} \left(\frac{\partial q_{b'}}{\partial x_{a'}} - \frac{\partial q_{a'}}{\partial x_{b'}} \right) + \\ &+ \Sigma(\overline{ab}) \overline{\psi}_{ab} \chi_{ab} + \Sigma(a) K_a \delta x_a \dots \dots \dots (38) \end{aligned}$$

Here, in the transformation of the first term on the right hand side it is found convenient to introduce a new notation for the quantities $\overline{\psi}_{ab}$. We shall put

$$\overline{\psi}_{ab} = \psi_{a'b'},$$

$$\begin{aligned} L' &= \frac{1}{4} \Sigma(ab) \psi'_{ab} \overline{\psi}'_{ab} = \frac{1}{4} |p| \Sigma(abcdef) \pi_{ca} \pi_{db} p_{ea} p_{fb} \psi_{cd} \overline{\psi}_{ef} = \\ &= \frac{1}{4} |p| \Sigma(cd) \psi_{cd} \overline{\psi}_{cd} = |p| L, \end{aligned}$$

while

$$|p| dS' = dS.$$

a consequence of which is

$$\psi_{ba}^* = -\psi_{ab}^*$$

and we shall complete our definition by¹⁾

$$\psi_{aa}^* = 0 \dots \dots \dots (39)$$

The term we are considering then becomes

$$\begin{aligned} \sum (\overline{ab}) \psi_{a'b'}^* \left(\frac{\partial q_{b'}}{\partial x_{a'}} - \frac{\partial q_{a'}}{\partial x_{b'}} \right) &= \sum (\overline{ab}) \psi_{ab}^* \left(\frac{\partial q_b}{\partial x_a} - \frac{\partial q_a}{\partial x_b} \right) = \\ &= \frac{1}{2} \sum (ab) \psi_{ab}^* \left(\frac{\partial q_b}{\partial x_a} - \frac{\partial q_a}{\partial x_b} \right) = - \sum (ab) \psi_{ab}^* \frac{\partial q_a}{\partial x_b} = \\ &= - \sum (ab) \frac{\partial (\psi_{ab}^* q_a)}{\partial x_b} + \sum (ab) \frac{\partial \psi_{ab}^*}{\partial x_b} q_a, \end{aligned}$$

so that, using (14), we obtain for (38)

$$\begin{aligned} \delta L + \sum (a) K_a \delta x_a &= - \sum (ab) \frac{\partial (\psi_{ab}^* q_a)}{\partial x_b} + \sum (ab) \frac{\partial \psi_{ab}^*}{\partial x_b} q_a + \\ &+ \sum (ab) \overline{\psi_{ab}} w_b \delta x_a + \sum (a) K_a \delta x_a, \dots \dots (40) \end{aligned}$$

where we have taken into consideration that

$$\sum (\overline{ab}) \overline{\psi_{ab}} (w_b \delta x_a - w_a \delta x_b) = \sum (\overline{ab}) \overline{\psi_{ab}} w_b \delta x_a.$$

If we multiply (40) by dS and integrate over the space S the first term on the right hand side vanishes. Therefore (12) requires that in the subsequent terms the coefficient of each q_a and of each δx_a be 0: Therefore

$$\sum (b) \frac{\partial \psi_{ab}^*}{\partial x_b} = 0 \dots \dots \dots (41)$$

and

$$K_a = - \sum (b) \overline{\psi_{ab}} w_b, \dots \dots \dots (42)$$

by which (40) becomes

$$\delta L + \sum (a) K_a \delta x_a = - \sum (ab) \frac{\partial (\psi_{ab}^* q_a)}{\partial x_b} \dots \dots \dots (43)$$

In (41) we have the second set of four electromagnetic equations, while (42) determines the forces exerted by the field on the charges. We see that (42) agrees with (19) (namely in virtue of (31)).

§ 12. To deduce also the equations for the momenta and the energy we proceed as in § 6. Leaving the gravitation field unchanged we shift the electromagnetic field, i. e. the values of w_a and ψ_{ab} in the direction of one of the coordinates, say, of x_c , over a distance defined by the constant variation δx_c so that we have

¹⁾ The quantities ψ_{ab}^* are connected with the quantities φ_{ab}^* introduced by EINSTEIN by the equation $\psi_{ab}^* = \sqrt{-g} \cdot \varphi_{ab}^*$.

$$\delta\psi_{ab} = -\frac{\partial\psi_{ab}}{\partial x_c} \delta x_c$$

From (36), (14) and (37) we can infer what values must then be given to the quantities q_a . We must put $q_c = 0$ and for $a \neq c$ ¹⁾

$$q_a = \psi_{a'c} \delta x_c.$$

For δL we must substitute the expression (cf. § 6)

$$\left\{ -\frac{\partial L}{\partial x_c} + \left(\frac{\partial L}{\partial x_c} \right)_\psi \right\} \delta x_c,$$

where the index ψ attached to the second derivative indicates that only the variability of the coefficients (depending on g_{ab}) in the quadratic function L must be taken into consideration. The equation for the component K_c which we finally find from (43) may be written in the form

$$K_c + \left(\frac{\partial L}{\partial x_c} \right)_\psi = -\sum (b) \frac{\partial T_{bc}}{\partial x_b}, \dots \dots \dots (44)$$

where

$$T_{cc} = -L + \sum_{a \neq c} (a) \psi_{ac}^* \psi_{a'c'}. \dots \dots \dots (45)$$

and for $b \neq c$

$$T_{bc} = \sum_{a \neq c} (a) \psi_{ab}^* \psi_{a'c'}. \dots \dots \dots (46)$$

Equations (44) correspond exactly to (24). The quantities T have the same meaning as in these latter formulae and the influence of gravitation is determined by $\left(\frac{\partial L}{\partial x_c} \right)_\psi$ in the same way as it was formerly by $\left(\frac{\partial L}{\partial x_c} \right)_w$.

We may remark here that the sum in (45) consists of three and that in (46) (on account of (39)) of two terms.

Referring to (35), we find f.i. from (45)

$$T_{11} = \frac{1}{2} (\psi_{43} \overline{\psi_{43}} + \psi_{42} \overline{\psi_{42}} - \psi_{41} \overline{\psi_{41}} + \psi_{23} \overline{\psi_{23}} - \psi_{31} \overline{\psi_{31}} - \psi_{12} \overline{\psi_{12}}),$$

while (46) gives

$$T_{12} = \psi_{31} \overline{\psi_{23}} - \psi_{41} \overline{\psi_{42}}.$$

The differential equations of the gravitation field.

§ 13. The equations which, for a given material or electromagnetic system, determine the gravitation field caused by it can also be derived from a variation principle. EINSTEIN has prepared the way

¹⁾ To understand this we must attend to equations (25).

for this in his last paper by introducing a quantity which he calls H and which is a function of the quantities g_{ab} and their derivatives, without further containing anything that is connected with the material or the electromagnetic system. All we have to do now is to add to the left hand side of equation (12) a term depending on that quantity H . We shall write for it the variation of

$$\frac{1}{\kappa} \int Q dS,$$

where κ is a universal constant, while Q is what EINSTEIN calls $H\sqrt{-g}$, with the same or the opposite sign¹⁾. We shall now require that

$$\delta \int L dS + \frac{1}{\kappa} \delta \int Q dS + \int \Sigma(a) K_a \delta x_a \cdot dS = 0, \dots (47)$$

not only for the variations considered above but also for variations of the gravitation field defined by δg_{ab} , if these too vanish at the limits of the field of integration.

To obtain now

$$\delta L + \frac{1}{\kappa} \delta Q + \Sigma(a) K_a \delta x_a$$

we have to add to the right hand side of (17) or (40), first the change of L caused by the variation of the quantities g , viz.

$$\Sigma(\overline{ab}) \frac{\partial L}{\partial g_{ab}} \delta g_{ab},$$

and secondly the change of Q multiplied by $\frac{1}{\kappa}$. This latter change is

$$\Sigma(\overline{ab}) \frac{\partial Q}{\partial g_{ab}} \delta g_{ab} + \Sigma(\overline{ab} e) \frac{\partial Q}{\partial g_{ab,e}} \delta g_{ab,e},$$

where $g_{ab,e}$ has been written for the derivative $\frac{\partial g_{ab}}{\partial x_e}$.

As

$$\delta g_{ab,e} = \frac{\partial \delta g_{ab}}{\partial x_e}$$

we may replace the last term by

$$\Sigma(\overline{ab} e) \frac{\partial}{\partial x_e} \left(\frac{\partial Q}{\partial g_{ab,e}} \delta g_{ab} \right) - \Sigma(\overline{ab} e) \frac{\partial}{\partial x_e} \left(\frac{\partial Q}{\partial g_{ab,e}} \right) \delta g_{ab}.$$

§ 14. As we have to proceed now in the same way in the case

¹⁾ I have not yet made out which sign must be taken to get a perfect conformity to EINSTEIN'S formulae.

of a material and in that of an electromagnetic system we need consider only the latter. The conclusions drawn in § 11 evidently remain valid, so that we may start from the equation which we obtain by adding the new terms to (43). We therefore have

$$\delta\dot{L} + \frac{1}{\kappa} \delta Q + \Sigma(a) K_a \delta x_a = - \Sigma(ab) \frac{\partial(\Psi_{ab}^* q_a)}{\partial x_b} + \frac{1}{\kappa} \Sigma(\overline{abe}) \frac{\partial}{\partial x_c} \left(\frac{\partial Q}{\partial g_{ab,e}} \delta g_{ab} \right) + \Sigma(\overline{ab}) \left(\frac{\partial L}{\partial g_{ab}} + \frac{1}{\kappa} \frac{\partial Q}{\partial g_{ab}} \right) \delta g_{ab} - \frac{1}{\kappa} \Sigma(\overline{abe}) \frac{\partial}{\partial x_e} \left(\frac{\partial Q}{\partial g_{ab,e}} \right) \delta g_{ab} \dots (48)$$

When we integrate over S , the first two terms on the right hand side vanish. In the terms following them the coefficient of each δg_{ab} must be 0, so that we find

$$\frac{\partial Q}{\partial g_{ab}} - \Sigma(e) \frac{\partial}{\partial x_e} \left(\frac{\partial Q}{\partial g_{ab,e}} \right) = - \kappa \frac{\partial L}{\partial g_{ab}} \dots (49)$$

These are the differential equations we sought for. At the same time (48) becomes

$$\delta L + \frac{1}{\kappa} \delta Q + \Sigma(a) K_a \delta x_a = - \Sigma(ab) \frac{\partial(\Psi_{ab}^* q_a)}{\partial x_b} + \frac{1}{\kappa} \Sigma(\overline{abe}) \frac{\partial}{\partial x_c} \left(\frac{\partial Q}{\partial g_{ab,e}} \delta g_{ab} \right) (50)$$

§ 15. Finally we can derive from this the equations for the momenta and the energy of the gravitation field. For this purpose we impart a virtual displacement δx_c to this field only (comp. §§ 6 and 12). Thus we put $\delta x_a = 0$, $q_a = 0$ and

$$\delta g_{ab} = - g_{ab,c} \delta x_c.$$

Evidently

$$\delta Q = - \frac{\partial Q}{\partial x_c} \delta x_c$$

and (comp. § 12)

$$\delta L = - \left(\frac{\partial L}{\partial x_c} \right) \delta x_c.$$

After having substituted these values in equation (50) we can deduce from it the value of $\left(\frac{\partial L}{\partial x_c} \right)$.

If we put

$$T_{cc}^g = - \frac{1}{\kappa} Q - \frac{1}{\kappa} \Sigma(\overline{ab}) \frac{\partial Q}{\partial g_{ab,c}} g_{ab,c} \dots (51)$$

and for $e \neq c$

$$T_{ec}^g = - \frac{1}{\kappa} \Sigma(\overline{ab}) \frac{\partial Q}{\partial g_{ab,e}} g_{ab,c} \dots (52)$$

the result takes the following form

$$-\left(\frac{\partial L}{\partial x}\right)_b = -\sum (e) \frac{\partial T_{ec}^g}{\partial x_e} \dots \dots \dots (53)$$

Remembering what has been said in § 12 about the meaning of $\left(\frac{\partial L}{\partial x_c}\right)_b$, we may now conclude that the quantities T_{ab}^g have the same meaning for the gravitation field as the quantities T_{ab} for the electromagnetic field (stresses, momenta etc.). The index g denotes that T_{ab}^g belongs to the gravitation field.

If we add to (53) the equations (44), after having replaced in them b by e , we obtain

$$K_c = -\sum (e) \frac{\partial T_{ec}^t}{\partial x_e}, \dots \dots \dots (54)$$

where

$$T_{ec}^t = T_{ec} + T_{ec}^g.$$

The quantities T_{ec}^t represent the *total* stresses etc. existing in the system, and equations (54) show that in the absence of external forces the resulting momentum and the total energy will remain constant.

We could have found directly equations (54) by applying formula (50) to the case of a common virtual displacement δx_c imparted both to the electromagnetic system and to the gravitation field.

Finally the differential equations of the gravitation field and the formulae derived from them will be quite conform to those given by EINSTEIN, if in Q we substitute for H the function he has chosen.

§ 16. The equations that have been deduced here, though mostly of a different form, correspond to those of EINSTEIN. As to the covariancy, it exists in the case of equations (18), (24), (41), (42) and (44) for any change of coordinates. We can be sure of it because LdS is an invariant.

On the contrary the formulae (49), (53) and (54) have this property only when we confine ourselves to the systems of coordinates adapted to the gravitation field, which EINSTEIN has recently considered. For these the covariancy of the formulae in question is a consequence of the invariancy of $\delta \int H dS$ which EINSTEIN has proved by an ingenious mode of reasoning.

[The page contains extremely faint and illegible text, likely bleed-through from the reverse side of the document. The text is scattered across the page and cannot be transcribed accurately.]

KONINKLIJKE AKADEMIE VAN WETENSCHAPPEN
TE AMSTERDAM.

PROCEEDINGS

VOLUME XIX

N^o. 5.

President: Prof. H. A. LORENTZ.

Secretary: Prof. P. ZEEMAN.

(Translated from: "Verslag van de gewone vergaderingen der Wis- en
Natuurkundige Afdeling," Vol. XXV).

CONTENTS.

- A. H. W. ATEN: "On some Particular Cases of Current Potential Lines". II. (Communicated by Prof. A. F. HOLLEMAN), p. 768.
- C. OTTO ROELOFS: "An exact method for the determination of the position of the eyes at disturbances of motion." (Communicated by Prof. G. VAN RIJNBERK), p. 778.
- J. C. KLUYVER: "The primitive divisor of x^m-1 ", p. 785.
- C. H. H. SPRONCK and Miss WILHELMINA HAMBURGER: "On passive immunisation against tetanus." p. 789.
- F. E. C. SCHEFFER: "On the Allotropy of the Ammonium Halides." III. (Communicated by Prof. P. ZEEMAN), p. 798.
- J. A. HONING: "Variability of segregation in the hybrid." (Communicated by Prof. F. A. F. C. WENT), p. 805.
- F. A. H. SCHREINEMAKERS: "In-, mono- and divariant equilibria." XII, p. 816.

Chemistry. -- "*On some Particular Cases of Current Potential Lines*".

II. By Dr. A. H. W. ATEN. (Communicated by Prof. A. F. HOLLEMAN).

(Communicated in the meeting of October 28, 1916.)

In the preceding paper¹⁾ an equation was derived which represents the ratio between the quantity of silver chloride which is deposited on the anode in case of anodic polarisation of a silver electrode in a solution of a chloride, and that which is deposited in the liquid. This equation now enables us to indicate in what way the electrolytical determination of halogens as silver halides takes place with the smallest error possible.

In these determinations the conditions must be satisfied that the halogen is deposited as completely as possible on the anode as silver halide and that as little silver as possible goes into solution from the anode.

During the analysis the halogen content of the liquid diminishes continually. The course of the process can therefore not be indicated by a single current potential line, but only by a number of current potential lines for all concentrations which the halogen ion passes through from the beginning to the end of the analysis. If e.g. we electrolyse a 0.01 *n* solution of NaCl, the course is in the beginning represented by line 1 in Fig. 2 of the preceding paper. If in course of time the solution has become 0.001 *n*, line 2 is applicable, later on, when the concentration has become 0.0001, line 3 applies, etc. As was demonstrated on p. 668 the points on the leftside of *AB* give current densities which chiefly yield AgCl on the anode. If $C_1 = 0.01$ we can, therefore, work with a comparatively large current density, without Ag appreciably going into solution. For $C_1 = 0.001$ this current density is ten times smaller, for $C_1 = 0.0001$ a hundred times smaller, etc.

If we now wanted to execute the electrolysis with a constant current density, till C_1 had become = 0.0001, we should have to work with a very small current density from the very beginning, for which with $C_1 = 0.0001$ no appreciable quantity of Ag goes into solution. In consequence of this the analysis would last very long. It is more advisable to work with a greater current density, as long as C_1 is still great, and diminish it according as C_1 descends. This may be done by measuring the anode potential during the analysis, and by regulating the intensity of the current so that the

1) These Proc. Vol. XIX, p. 653.

anode potential, hence the concentration of the silver ions at the anode, keeps a definite value, or varies in a definite way.

When during the electrolysis the concentration of the chlorine ions at the anode is kept at a constant value c_{1a} , the ratio $\frac{d_2}{d_1}$ is constant during the electrolysis, and equal to:

$$\frac{d_2}{d_1} = \frac{D_2}{D_1} \frac{L}{c_{1a}^2} \quad \dots \quad (1)$$

For silver chloride L is about 10^{-10} . If c_{1a} is kept at 10^{-4} , $\frac{d_2}{d_1}$ will be about 0.01, D_1 and D_2 differing little. Hence 1% of the total quantity of chlorine will precipitate in the liquid as AgCl. This quantity is lost for the analysis. The error made in the analysis, is, however, greater than 1%, for the increase in weight of the anode is determined. This is 1% too small, because AgCl precipitates in the liquid, but this causes a quantity of Ag of the anode to go into solution, which is equivalent to 1% chlorine, hence about three times the quantity. The total error amounts, therefore, to about 4%. This error would be smaller, if the analysis was carried out for $c_{1a} = 10^{-3}$. In this case $\frac{d_2}{d_1}$ would be $= 10^{-4}$. But now there remains in the solution a quantity of chlorine ions equal to 10^{-3} ; to reach, therefore, an accuracy of 1% we should have to start from a solution which is 0.1 normal. The total quantity of AgCl that must separate from this solution, is pretty large, for which a large silver surface is necessary, as the quantity of AgCl that can be deposited on a given anode surface, is comparatively small. It appears, therefore, that an accurate determination of Cl presents difficulties. More favourable are the circumstances for Br and I, as the solubility products of AgBr and AgI are 10^{-12} and 10^{-16} . We can, therefore, work for AgBr with $c_{1a} = 10^{-4}$, and for AgI with 10^{-6} , without an appreciable loss taking place.

The loss of silver chloride becomes slightly smaller when c_{1a} is not kept at a constant value from the beginning, but allowed to diminish during the electrolysis, so that c_{1a} has a greater value at the beginning of the experiment than at the end.

Let us suppose the intensity of the current to be so regulated that c_{1a} always remains equal to nC_1 , n being a constant smaller than 1.

Now:

$$\frac{d_2}{d_1} = \frac{D_2}{D_1} \cdot \frac{L}{n^2 C_1^2}$$

At the beginning of the analysis, where C_1 is great, $\frac{d_2}{d_1}$ is, therefore, smaller than at the end, where C_1 has descended to a small value. If we call this initial and this final value C_{1b} and C_{1e} , the mean value of $\frac{d_2}{d_1}$ during the analysis is:

$$\frac{d_2}{d_1} = \frac{\int_{C_{1b}}^{C_{1e}} \frac{D_2}{D_1} \cdot \frac{L}{n^2 C_1^2} dC_1}{C_{1b} - C_{1e}}$$

or

$$\frac{d_2}{d_1} = \frac{D_2}{D_1} \cdot \frac{L}{n^2} \cdot \frac{1}{C_{1b} C_{1e}} \dots \dots \dots (2)$$

For a given value of C_{1b} and C_{1e} the value of $\frac{d_2}{d_1}$ is now determined by n .

If we assume $n = 0.5$, $C_{1b} = 0.01$, $C_{1e} = 0.00004$, then $\frac{d_2}{d_1} = 10^{-3}$.

As a quantity of silver of the anode dissolves which is about three times the value of the deficit of chlorine, the diminution of weight of the anode is found 0.4×10^{-2} too small. Moreover the concentration of the chlorine ions in the solution remains 0.00004 at the end of the determination, hence 0.4 % of the original quantity. Hence with this mode of working the total error is 0.8 %.

If n is taken greater, e. g. = 1, and $C_{1e} = 0.00002$, the shortage of AgCl on the anode becomes 0.2 %, 0.2 % of the chloride remaining in solution, so that the total error amounts here to 0.4 %.

With the given value of C_{1b} a smaller error cannot be reached. This would only be possible by making C_{1b} greater, but this requires a very large silver surface. Nor is the above given value for $n = 1$ practically to be realized, as in this case the current density would become = 0.

In general the current density becomes greater, hence the time required for the execution of the analysis shorter, as n is smaller. The accuracy of the analysis, is however diminished by this.

The duration of the analysis can be calculated in the following way.

When we work with a current density smaller than the critical,

as in practice is always the case, the current density is given with great approximation by:

$$d = 1.117 \frac{D_1}{\delta} (C_1 - c_{1a}), \quad \text{or as } c_{1a} = nC_1$$

$$d = 1.117 \frac{D_1}{\delta} (1 - n) C_1.$$

If the total quantity of halogen is M gramme equivalents, the diminution of this per time unit is equal to the current strength, divided by 96500, hence:

$$-\frac{dM}{dt} = \frac{Od}{96500} \quad \text{if } O \text{ is the surface of the anode.}$$

If further the volume of the solution is V , then $M = VC_1$, and consequently:

$$-\frac{dC_1}{dt} = \frac{Od}{96500V} = \frac{OD_1}{86400\delta V} (1-n) C_1$$

from which follows:

$$t = \frac{86400\delta V}{OD_1(1-n)} \times 2.3 \log \left(\frac{C_{1b}}{C_{1e}} \right). \quad \dots \quad (3)$$

It appears from this equation that for a given value of C_{1b} and C_{1e} the analysis will proceed the more rapidly as δ is smaller, consequently as the stirring is more vigorous, the volume is smaller, n is smaller, and O and D_1 are greater. D_1 may be increased by rise of temperature. A large area of the anode is particularly desirable here because the deposited silver chloride covers the metal, and the effective area becomes, therefore, smaller during the analysis.

The electro-analytical determination of the halogens has been fully examined by SMITH¹⁾ and his collaborators, and the recorded results are satisfactory. The method for chlorides has appeared to give the best results when the solution contains a sufficient quantity of OH-ions. to form AgOH with the silver, when the chlorine ions are almost consumed. In this way the loss of silver of the anode is prevented. In consequence of the precipitated AgOH the anode weighs too heavy, but the silver hydroxide can be easily decomposed by heating, so that the increase of weight now actually gives the deposited chlorine. There always remains a deficit, however, as not all the chlorine from the solution can be deposited. For the other halogens the error will be smaller than for chlorine, when the same method of working is followed.

The difference between the three halogens appears clearly from a research by REEDY²⁾, who found a deficit of 0.2% for a diluted acid

¹⁾ SMITH, Electroanalysis.

²⁾ Amer. Journ. of Science. (4) 40 (1915) 281, 400.

solution of iodide, of 0.8 % for bromide, and of 20 % for chloride.

That the error for chloride is so exceedingly large, larger than is necessary, is owing to REEDY'S method of working. He wanted, namely, to precipitate halogen, till no more than 0.1 mgr. was left in 200 cm³ of the solution. For this purpose he calculated the potential which a silver electrode covered with AgCl presents in a solution of 0.1 mgr. per 200 cm³, and then carried out the electrolysis for this constant anode potential. Hence the halogen concentration at the anode was kept constant, and c_{1a} in equation (1) had the value 0.000014 for Cl, the value 0.000007 for Br, and 0.000003 for I.

The ratio of the quantity of silver halide, which precipitates in the liquid to that which precipitates on the anode is according to (1)

$$\frac{d_2}{d_1} = \frac{D_2}{D_1} \cdot \frac{L}{c_{1a}^2}$$

As now L_{AgCl} is about 1.4×10^{-10} , L_{AgBr} 5×10^{-13} , and L_{AgI} 10^{-16} , $\frac{d_2}{d_1}$ becomes 0.7 for chlorine, 0.01 for bromine, and 0.001 for iodine.

The value calculated here for silver chloride is much greater than that of REEDY, which can be explained by this that the values of c_{1a} used are not very accurate. When c_{1a} differs little from \sqrt{L} , a small error in c_{1a} gives a great change in the value $\frac{d_2}{d_1}$. For AgBr and AgI, where c_{1a} is much smaller than \sqrt{L} , an error in c_{1a} brings about only a small absolute change in $\frac{d_2}{d_1}$.

As for 1% bromine that precipitates in the liquid as AgBr, about $1\frac{1}{2}$ times the amount of silver of the anode dissolves, the total error calculated for the bromine determination is about 2.5 %. In the iodine determination it amounts to about 0.2 %. It appears, therefore, that in these latter determinations the calculated error corresponds in order of magnitude with the deficit in REEDY'S determinations.

As was already observed above the determination of chlorine as silver chloride can be made more accurate than was done by REEDY. For this purpose the concentration of the chlorine ions at the anode must be kept at a higher value, e.g. 1 mgr. instead of 0.1 mgr. per 200 cm³.

Further REEDY has determined some current potential lines, as they have been drawn in fig. 2 of the first paper, among other things for KI (fig. 3 p. 286 REEDY). A quantitative comparison of the theo-

retical and the experimental line is not possible. Qualitatively the agreement is perfect. It appears from the course of the lines 1 and 2 in fig. 2 that the middle of the horizontal part of these lines lies at a concentration equal to \sqrt{L} . Hence at $c_{1a} = 10^{-8}$ for AgI, which corresponds with a potential of + 0.34 Volt. It appears from REEDY's line that the middle of the horizontal portion really lies at this potential.

This is different with a line given by REEDY for AgBrO_3 in 0.5 molecular KBrO_3 . Here the middle of the horizontal portion lies at about 0.470 V, corresponding with a silver ion concentration of 10^{-6} . Then the product of solubility of AgBrO_3 would be 10^{-12} . This value is much too small for AgBrO_3 . For the solubility BÖTTGER¹⁾ found 7×10^{-3} mol. per L. As for this dilution AgBrO_3 is almost totally ionized, the product of solubility will be about 5×10^{-5} . The product of solubility found from REEDY's line, is therefore certainly not that of AgBrO_3 . Its value agrees pretty well with that of AgBr , which leads us to the supposition that REEDY's line does not refer to AgBrO_3 in KBrO_3 , but to AgBr in KBr , which might be the case if the bromate used was contaminated with bromide. This supposition is supported by what follows. For the potential of AgBrO_3 in 0.5 molecular KBrO_3 without polarisation REEDY finds 0.400 V., which yields a product of solubility for AgBrO_3 of 10^{-7} .

As was demonstrated above this value is too low. If we assume the measured potential to refer to AgBr in KBr , the solution used would have to contain 10^{-5} KBr , for which it would be therefore necessary that the bromate used was contaminated with 0.002% bromide.

Besides, the length of the horizontal piece in the line of REEDY is slightly more than 0.1 Volt, as is required for a silver salt, for which $\sqrt{L} = 10^{-6}$ in a solution which is 10^{-5} molecular at the anion. For AgBrO_3 in 0.5 molecular KBrO_3 the horizontal portion would have to be about twice as long.

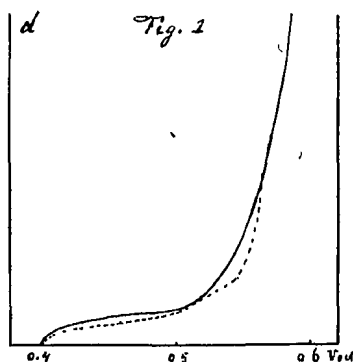

In fig. 1 the line found by REEDY is drawn, the dotted line is the calculated one of AgBr in 10^{-5} n. KBr , in which the scale of the current densities is chosen so that a point of the calculated line coincides with a point of the found line.

It appears that there exists a satisfactory agreement between these two lines, when it is borne in mind that

¹⁾ Z. f. physik. Chemie. 46 (1903) 602.

the value of 10^{-5} of the bromine ion concentration is correct only in approximation.

If we assume that the product of solubility of AgBrO_3 is 5×10^{-5} , the concentration of the silver ions is 10^{-4} in 0.5 molecular KBrO_3 . The current tension line of AgBrO_3 in KBrO_3 would not begin therefore before 0.57 V., and would therefore be a continuation of the one drawn in figure 1.

5. *Anodic formation of metal compounds in the solution.*

In the preparation of insoluble metal compounds by electrolytical way according to Lückow, we wish to attain that the precipitation does not form on the anode, but in the liquid. The conditions for this follow immediately from figure 3 of the first paper and from equation (43)

It is clear that we shall have to work with a current density greater than the critical density hence:

$$d > \frac{1.117}{\sigma} (D_1 C_1 - D_2 C_2).$$

The current density need only be little greater than this value to make all the precipitation form in the liquid. This condition will the sooner be satisfied as C_1 is smaller and σ greater. That is to say that the concentration of the anion, which gives a precipitate with the metalion, must be small, and the liquid should not be stirred or only slightly. These are the very same conditions as Lückow gives for his mode of working.

6. *Electrolysis of solutions of complex salts.*

In the electrolysis of solutions of complex salts, e.g. $\text{Ag}_2(\text{CN})_2$ dissolved in KCN, a precipitate can be formed on the anode under some circumstances, in this case of $\text{Ag}_2(\text{CN})_2$.

This very greatly increases the resistance, and enfeebles the current, so that it is necessary to prevent the formation of this precipitate. It is now easy to indicate at what current density this precipitate will be formed.

In a solution of $\text{Ag}_2(\text{CN})_2$ in KCN exist the equilibria:

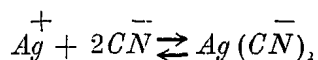

and

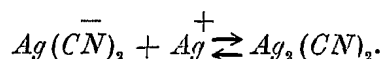

If we call the concentration of $\text{Ag}(\text{CN})_2^-$, Ag^+ , CN^- and $\text{Ag}_2(\text{CN})_2^+$ c_1 , c_2 , c_3 and c_4 , then

$$c_3 c_3^2 = K c_1 \quad \dots \dots \dots (4)$$

and

$$c_1 c_2 = K' c_4 \quad \dots \dots \dots (5)$$

When the solution is saturate with respect to $Ag_2(CN)_2$, (5) passes into:

$$c_2 c_1 = L \quad \dots \dots \dots (5a)$$

where L is the product of solubility of silvercyanide.

Now a precipitate will be formed on the anode, as soon as $c_{2a} c_{1a}$ has become L , and the electrolysis will have to be conducted so that $c_{2a} c_{1a}$ remains $< L$. c_{1a} , c_{2a} etc. denotes the concentration close to the anode, C_1 , C_2 etc. denoting the concentration at the boundary plane of the diffusion layer with the rest of the liquid.

According to § 2 of the preceding paper, the quantity of cyanogen ions diffusing per second towards the anode, is equal to:

$$\frac{D_3}{86400} \frac{C_3 - c_{3a}}{\delta}$$

So long as no $Ag_2(CN)_2$ is precipitated, these will form ions $Ag(\overline{CN})_2$ which move away from the anode through diffusion. The quantity of this is given by:

$$\frac{D_1}{86400} \frac{c_{1a} - C_1}{\delta}$$

From which follows that:

$$2 D_1 (c_{1a} - C_1) = D_3 (C_3 - c_{3a}) \quad \dots \dots \dots (6)$$

The current density is:

$$d = 1.117 D_1 \frac{c_{1a} - C_1}{\delta} \quad \dots \dots \dots (7)$$

This current density is therefore maintained through the cyanogen ions diffusing to the anode, and ions of $Ag(\overline{CN})_2$ being formed there, which diffuse away from the anode. If the current density is increased, it will attain a value at which not enough \overline{CN} diffuses to the anode for $Ag(\overline{CN})_2$ to be exclusively formed; also $Ag_2(CN)_2$ will then have to be formed at the anode. When the current density is regulated so that the solution at the anode is just saturate with $Ag_2(CN)_2$, but no appreciable quantity of $Ag_2(CN)_2$ is deposited, the equations (6) and (7) hold, and at the same time:

$$c_{2a} c_{1a} = L \quad \dots \dots \dots (5a)$$

and

$$c_{2a} c_{3a}^2 = K c_{1a} \quad \dots \dots \dots (4)$$

From (4), (5a), and (6) follows:

$$c_{1a} = \frac{2D_1C_1 + D_3C_3}{2D_1 + D_3 \sqrt{\frac{K}{L}}} \dots \dots \dots (8)$$

and from (7)

$$d = \frac{1.117}{\delta} D_1 \frac{D_3C_3 - D_3C_1 \sqrt{\frac{K}{L}}}{2D_1 + D_3 \sqrt{\frac{K}{L}}} \dots \dots \dots (9)$$

$\sqrt{\frac{K}{L}}$ is very small for silver cyanide, about 10^{-3} , and when C_1 is not very large with respect to C_3 we may write:

$$d = \frac{1.117}{2\delta} D_3 C_3 \dots \dots \dots (10)$$

This equation gives, therefore, the current density below which no deposition of a precipitate on the anode takes place.

It appears from it that this current density is the greater as the concentration of the complex former is greater, the diffusion coefficient greater, and δ smaller. By means of vigorous stirring and increase of temperature we can work with a greater current density.

For the rest the current density, at which the anode is covered with a precipitate, is about the same for all complex salts (for a same value of C_3), the coefficient of diffusion differing little. Of

course this holds only when $\sqrt{\frac{K}{L}}$ is small. The values of K

and L have, therefore, no influence. When now $\sqrt{\frac{K}{L}}$ is not very small, or C_1 great with respect to C_3 , equation (9) must be used instead of (10). The current density is now smaller, the numerator being smaller and the denominator greater than in (10).

The potential, at which the deposition of $Ag_2(CN)_2$ begins, is found by substitution of (9) in equation (16) of the preceding paper:

$$E = \varepsilon + 0.058 \text{ }^{10}\log K + 0.058 \text{ }^{10}\log \frac{2D_1C_3 - 2D_1C_1 \sqrt{\frac{K}{L}}}{2D_1 + D_3 \sqrt{\frac{K}{L}}} - 0.116 \text{ }^{10}\log \frac{D_3C_3 \sqrt{\frac{K}{L}} + 2D_1C_1 \sqrt{\frac{K}{L}}}{2D_1 + D_3 \sqrt{\frac{K}{L}}} \dots \dots \dots (11)$$

If, therefore, a current density prevails given by equation (9), the liquid just at the anode is saturate with $\text{Ag}_2(\text{CN})_2$, but not in more distant parts of the diffusion layer, as here the concentration of $\overline{\text{CN}}$ is greater, and the silver cyanide dissolves under formation of $\text{Ag}(\overline{\text{CN}})_2$. Hence the layer of silver cyanide will not become thicker for constant current density.

If the current density is increased, not enough $\overline{\text{CN}}$ -ions will diffuse to the anode to form again complex ions with the $\text{Ag}_2(\text{CN})_2$ formed by the $\text{Ag} + \text{Ag}(\overline{\text{CN}})_2$. Part of the cyanogen ions will now yield $\text{Ag}_2(\text{CN})_2$ with the silver of the anode. This part will be the greater as the current density is greater. For a given value of the latter practically all the $\text{Ag}(\overline{\text{CN}})_2$ and $\overline{\text{CN}}$ will be consumed to yield $\text{Ag}_2(\text{CN})_2$ at the anode. For a still greater value of d the silver will then go into solution as Ag^+ .

So long as the $\text{Ag}_2(\text{CN})_2$ is deposited only on the anode and not in the liquid, the following equation holds with close approximation:

$$d = \frac{1.117}{\delta} [D_1 (C_1 - c_{1a}) + D_3 (C_3 - c_{3a})] \quad \dots \quad (13)$$

or in connection with (4) and (5a):

$$d = \frac{1.117}{\delta} \left[D_1 \left(C_1 - \frac{L}{c_{2a}} \right) + D_3 \left(C_3 - \frac{\sqrt{KL}}{c_{2a}} \right) \right] \quad \dots \quad (14)$$

This equation combined with:

$$E = \epsilon + 0.058 \log c_{2a}$$

yields the current potential line.

When at last the current density becomes so great that the quantity of $\text{Ag}(\overline{\text{CN}})_2$ and $\overline{\text{CN}}$ diffusing to the anode, is not great enough to maintain this current density, silver ions will also go into solution, which precipitate at some distance from the anode as $\text{Ag}_2(\text{CN})_2$. This corresponds then with the precipitation of AgCl in the liquid, as has been treated in § 4. These two cases are, however, not properly comparable, as at the precipitation of AgCl the liquid is everywhere saturate with AgCl , whereas in the case of $\text{Ag}_2(\text{CN})_2$ the liquid in the diffusion layer is saturate with silver cyanide up to a certain distance from the anode, but not the whole liquid. Consequently an equation of the current potential line will hold here which agrees with that for AgCl in its main points, but not entirely.

Fig. 2 gives the current tension line of a solution which is $0.1n$ with respect to $\text{Ag}(\overline{\text{CN}})_2$ and $0.1n$ with respect to $\overline{\text{CN}}$. The portion BA holds for cathodic polarisation, AE for anodic polarisation.

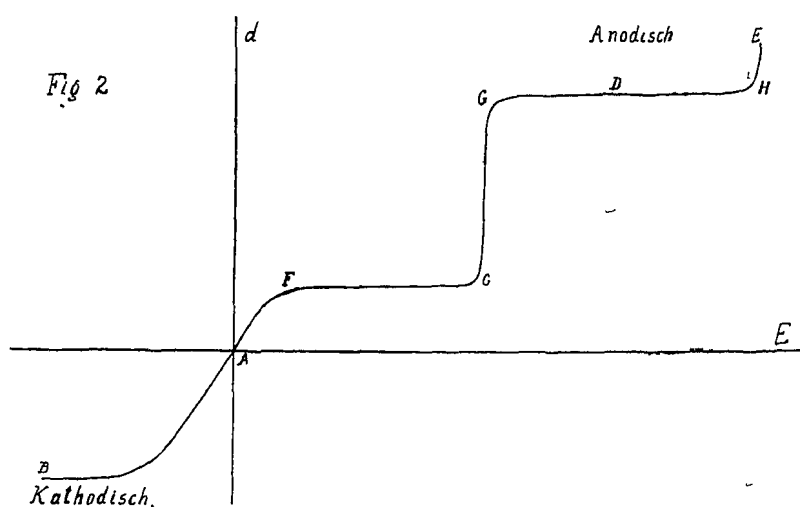

From A to C exclusively $\text{Ag}(\overline{\text{CN}})_2$ is formed. At C the deposition of $\text{Ag}_2(\text{CN})_2$ on the anode begins, from C to G it becomes greater and greater, at G besides the deposition of cyanogensilver on the anode, this compound also begins to precipitate in the liquid; at D the quantities of $\text{Ag}_2(\text{CN})_2$ being deposited on the anode and in the liquid are equal, and finally from H to E the cyanogen silver precipitates practically exclusively in the liquid.

It is clear that in practice a current density will be worked with which is smaller than F . It is, indeed, possible to make the current density somewhat greater than F without $\text{Ag}_2(\text{CN})_2$ being deposited on the anode, but this slight increase of the current density gives a very great increase of polarisation-tension, which can amount to about 0.4 or 0.5 V. A too great current density at the anode, therefore, gives rise here to an appreciable loss of energy.

Chemical Laboratory of the University.

Amsterdam, October 1916.

Physiology. "An exact method for the determination of the position of the eyes at disturbances of motion." By Dr. C. OTTO ROELOFS. (Communicated by Prof G. VAN RIJNBERK).

(Communicated in the meeting of October 28, 1916).

In a communication to the Meeting of the 26nd of January 1916 I indicated, in what way it is possible to calculate the position of the axis round which the eye has, as it were, turned, when we know the abduction, deorsumduction and inward rotation, caused

by a contraction of the m. obliquus superior. There exists however hardly any suitable method exactly to ascertain the position of the eyes. We shall at all events best succeed, if binocular vision exists (which will, as a rule, be the case for a paralysis or paresis) and we can make use of the position of the double-images for the purpose we have in view.

In the "Zeitschrift für Augenheilkunde" Vol. XXXV, N^o. 4 HESS indicates a method, based on the subjective localisation of the double-images. For clinical purposes this method is as a rule sufficient and highly to be recommended, for physiological investigation it can however not satisfy all the requirements that may be wanted.

I have tried to find a method that is more suitable to a similar purpose of which I intend to give here a description. Binocular vision and good correspondence of the retina is for this method likewise required.

The purpose of the investigation will consequently be exactly to ascertain the position of one of the two eyes, whilst the other eye has obtained a determined direction of regard by looking at an indicated point of fixation.

For this purpose the patient is placed directly opposite a vertical wall, at a distance of at least 3m. Directly in front of the patient, at a level with his eyes, a point O is marked on the wall. Now we suppose, that the distance from O to the point of rotation of the eye is $= a$ and that when the head is erect and at binocular fixation of O , both the eyes, are in the primary position, consequently in the position from which the normal eye moves according to the law of LISTING.

As second point we apply to the wall the point Q which must serve as point of fixation. In some cases we can make the points O and Q coincide as Fig. 1 indicates.

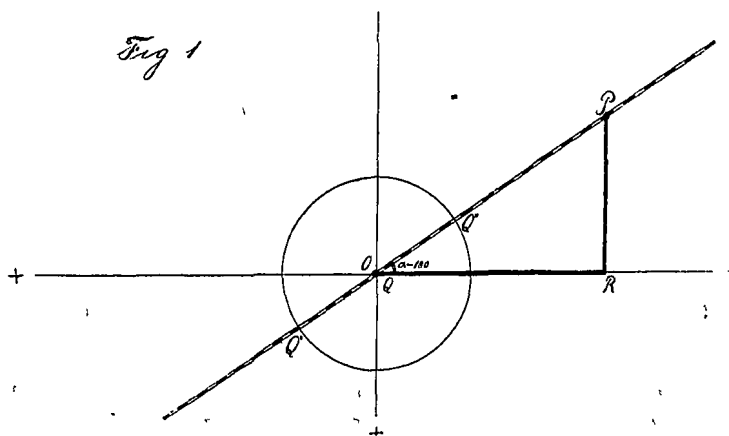
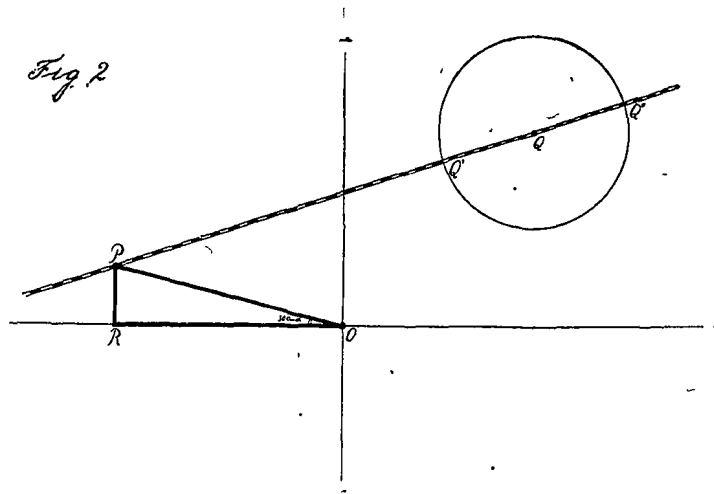

Fig. 2 gives an example of the more general case that these points do not coincide.



The investigation is to be separated into two parts. In the first part we shall describe the investigation into the direction of the line of regard, whilst in the second part the investigation of the rotation of the eye round its line of regard is treated.

The purpose of the first part of the investigation is to find the point P , where the line of regard of the examined eye cuts the wall, whilst the other eye fixes the point Q .

For this purpose we place exactly for Q a luminous point (short candle-flame) and place before the examined eye the rods of MADDox in a trial-frame. As long as the investigation lasts the fixing eye must constantly look at the point Q . Now the rods of MADDox in the trial-frame are turned till the luminous red line that the examined eye observes, apparently goes through Q .

We know then that the red line on the retina goes through the fovea of the examined eye. Now we remove the flame from Q and move it in a circle round Q , whilst the rods of MADDox before the examined eye have remained unaltered in their places. Twice the patient will then observe that the red line goes apparently through Q . The points where the flame is at these moments (Q' and Q'') are likewise marked on the wall. We know that we can draw straight lines through the points Q , Q' , and Q'' , which will likewise go through the point P , on which the line of regard of the eye behind the rods is directed, which we want to find. As on account of the unaltered position of the rods, the observed red line can only move parallel to itself, these three lines which contain all

three the point P , must coincide. Consequently P must lie on the line $Q' Q Q''$.

Thereupon we turn the rods of MADDOX in the trial-frame about 90° and now move the flame along the line $Q' Q Q''$ or its prolongation. At a given moment the red line will again apparently be seen in Q . This point is marked and will, as can easily be understood, be the point P we were in search of.

How are we now to describe more accurately the position of the point P , which we have found, or the direction of the line of regard? For this purpose we can follow two ways. In the first place we can express the direction of the line of regard in its abduction or adduction and in its deorsumduction or sursumduction.

By abduction and adduction we understand the smallest angle that the line of regard makes with the sagittal plane. If now we seek a formula for the abduction (A), then we shall call OR positive, when R lies temporally from O , so that the formula is: $tg A = \frac{OR}{\sqrt{a^2 + PR^2}}$.

If OR is negative, then $tg A$ is negative and there exists adduction.

By deorsumduction or sursumduction we shall understand the smallest angle that the line of regard makes with the horizontal plane. If now we seek a formula for the deorsumduction (D) we shall call PR positive, when P lies under the horizontal line, so that the

formula is: $tg D = \frac{PR}{\sqrt{a^2 + OR^2}}$.

If PR is negative (as in the Fig. 1 and 2) then $tg D$ is negative, and there is sursumduction. We have not to take account here of angles larger than 90° . If we wish to indicate the position of the line of regard in the manner as HELMHOLTZ has taught us (inclination of the plane of regard) then the deorsumduction is expressed by the

formula: $tg D' = \frac{PR}{a}$.

A second method of describing the direction of the line of regard is the following one. In the first place we can calculate the angle, that the line of regard in the position we have found, makes with the line of regard in the primary position, and afterwards the angle that OP makes with OR . We shall call these angles respectively

$\angle H$ and $\angle \alpha$. For $\angle H$ the formula is: $tg H = \frac{OP}{a} = \frac{\sqrt{PR^2 + OR^2}}{a}$.

For $\angle \alpha$ the formula is $\sin \alpha = \frac{PR}{\sqrt{PR^2 + OR^2}}$ and $tg \alpha = \frac{PR}{OR}$.

As α can have all values from 0° to 360° we shall agree, that

$\angle \alpha$ is calculated from the horizontal plane temporalward downward. In Fig. 1 OP lies consequently in the third quadrant, in Fig. 2 in the fourth quadrant. If now we call OR positive, when R lies temporally and PR positive when P lies under the horizontal plane, then two values will in general satisfy the formula for $\sin \alpha$, and also two that for $\tan \alpha$, but only one value will satisfy both formulas, consequently $\angle \alpha$ is determined.

For the first part of the investigation we have consequently calculated the angles A , D , H and α from the data a , PR and OR .

In the second part of the investigation we must learn to know the rotation of the eye round its line of regard. If we call the position that the eye must assume according to the law of LISTING during its different directions of regard the normal position, then we can make it our task to ascertain, if, how much and in what direction the eye has rotated round its line of regard in relation to that normal position.

Let Q again be the point of fixation and P the point where the line of regard of the examined eye cuts the wall. Now we place a source of light in P and hold before the examined eye again the rods of MADDUX, as perpendicularly to the line of regard as possible. We now move the rods in their plane so long, till the red line is apparently seen horizontal (as the thin dotted line in Fig. 3 going

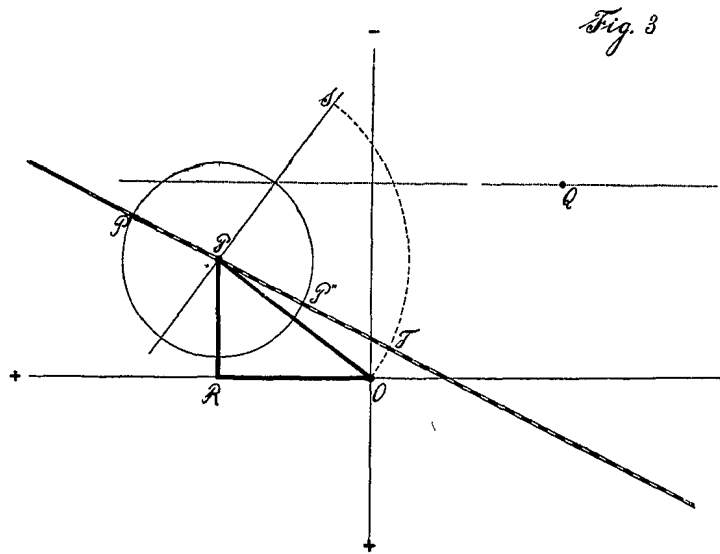

through Q indicates). Leaving the rods in this position we remove the flame from P and move it in a circle round P . The points where the flame is, when the red line goes again apparently through Q (namely P' and P'') are marked, and it needs no further demon-

stration, that $P'PP''$ is a line, that is observed by the examined eye as horizontal, i. e. forms an image on the horizontal meridian of the retina. If now we represent to ourselves a plane through the horizontal meridian of the retina and $P'PP''$ and likewise a plane through OP and the meridian of the retina corresponding with it,

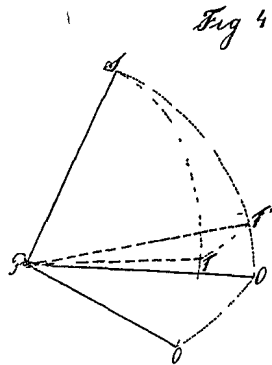

then in normal cases, the angle between these two planes must be equal to $\angle POR$. We must however take into consideration, that the angle between the mentioned planes is not expressed in the angle OPT , because the wall does not stand perpendicularly to the secant line of the two planes, namely the line of vision (coinciding nearly with the line of regard). If we represent to ourselves however a plane in P perpendicular to the line of regard and further a globe constructed with P as central point and PO as radius (vide Fig. 4) then it is easy to see, that in the rectangular spherical triangle $ST'T \text{ tg } SPT' = \cos S \text{ tg } SPT$ or $\cot OPT' = \cos H \cot OPT$.

If we call $\angle OPT' = \beta$, then the difference between β and $\angle POR$ indicates the rotation we wanted to find.

$$\text{tg } (POR - \beta) = \frac{\text{tg } POR - \text{tg } \beta}{1 + \text{tg } POR \text{ tg } \beta} = \frac{PR - RO \text{ tg } \beta}{RO + PR \text{ tg } \beta}$$

and as $\text{tg } \beta = \frac{\text{tg } OPT}{\cos H}$ the rotation (R) is expressed by the formula

$$\text{tg } R = \frac{PR \cos H - RO \text{ tg } OPT}{RO \cos H + PR \text{ tg } OPT}$$

Consequently we have to calculate $\text{tg } OPT$. If we no longer regard T as the point of intersection of $P'P''$ with the spherical surface, but as the point of intersection of $P'P''$ with the perpendicular to $P'P''$ passing through O , then: $\text{tg } OPT = \frac{OT}{PT}$.

We must however carefully pay attention to the marks (\pm) in order to find the exact value for the rotation. In concurrence with the first part of the investigation we shall call PR positive, when P lies under the horizontal line and RO positive when R lies temporalward from the vertical line. If now we express $\angle POR$ in its tangent, $\text{tg } POR$ is positive, when P lies under the horizontal line and temporalward from the vertical line or over the horizontal line and noseward from the vertical line.

We shall likewise call OT positive when O lies under the line

PT and PT positive, when T lies temporalward from P ; consequently $tg OPT$ will be positive, when O lies under PT and temporalward from P or over PT and noseward from P .

If now we apply this rule, we shall find a positive value for the rotation, when the upper part of the vertical meridian of the retina inclines too much temporalward, a negative value when it inclines too much noseward.

For all our calculations we have consequently to measure on the wall: OR, PR, OT and PT , whilst the distance from the eye to the wall must be known.

Now we can ask how the axis lies, round which the eye would have to come from the primary position into the position we have found.

Some formulas for its calculation have been given in the communication mentioned above. I think it a good plan to repeat these formulas again, not only because this gives me an opportunity to correct a few troublesome printer's errors, but likewise because I can call attention to the fact, that these formulae do not serve exclusively to find the axis of the m. obliquus superior, but that they are of a much more general signification. In the former communication the rotation was called positive, when the upper part of the vertical meridian of the retina inclined nose-wardly; in connection with what is generally understood by positive cyclophoria, I suppose, I have been obliged to rectify this likewise.

The formulas mentioned run consequently:

$$\sin H = \sqrt{\sin^2 A + \sin^2 D}$$

$$tg \mu = \frac{tg \frac{1}{2} H}{\sin \frac{1}{2} R} \quad (\mu \text{ is always less than } 90^\circ).$$

$$\cos \lambda = -\frac{\sin \mu}{\sin H} (\sin D \cos \frac{1}{2} R - \sin A \sin \frac{1}{2} R)$$

$$\cos v = -\frac{\sin \mu}{\sin H} (\sin D \sin \frac{1}{2} R + \sin A \cos \frac{1}{2} R)$$

in which H = the angle between the line of regard in the position we have found and the primary position, A = Abduction, D = Deorsumduction, R = Rotation temporalward. λ = angle of the anterior half of the axis of motion with x -as (temporalward). u = angle of the anterior half of the axis of motion with y -axis (forward). v = angle of the anterior half of the axis of motion with z -axis (upward). The sign before μ indicates the direction in which the eye has rotated.

Mathematics. — “*The primitive divisor of $x^m - 1$* ”. By Prof. J. C. KLUYVER.

(Communicated in the meeting of November 25, 1916).

The binomial equation $x^m - 1 = 0$ has $M = \varphi(m)$ special roots, which do not belong to any binomial equation of lower degree. Denoting by ν the integers less than m and prime to m these special roots are of the form $x_\nu = e^{\frac{2\pi i \nu}{m}}$ and the product

$$F_m(x) = \prod (x - x_\nu)$$

is called by KRONECKER the primitive divisor of $x^m - 1$.

It is shewn that $F_m(x)$ cannot be resolved into rational factors and that the decomposition of $x^m - 1$ into rational prime factors is given by the equation

$$x^m - 1 = \prod_{d|m} F_d(x),$$

where d is successively equal to the different divisors of m , unity and m itself included.

By inverting this formula in the usual manner, we infer that

$$F_m(x) = x^M F_m\left(\frac{1}{x}\right) = \prod_{d|m} (x^d - 1)^{\mu(d)} = \prod_{d|m} (1 - x^d)^{\mu(d)},$$

$(dd' = m)$

In this fundamental equation $\mu(d')$ stands for zero, if d' has a square divisor and otherwise $\mu(d')$ equals $+1$ or -1 , according as d' is a product of an even or of an odd number of prime numbers.

From this expression of $F_m(x)$ the following properties of the primitive divisor may be deduced.

I. If $m = n_1 n_2$ and n_1 and n_2 are relatively prime, then

$$F_m(x) = \prod_{d|n_1} F_{n_2}(x^d)^{\mu\left(\frac{n_1}{d}\right)}$$

II. The greatest common measure of $F_{n_1}(x^{n_2})$ and $F_{n_2}(x^{n_1})$ is $F_{n_1 n_2}(x)$, n_1 and n_2 being prime to each other.

III. If m has at least two different prime divisors, then $F_m(1) = 1$, but $F_m(1) = p$, when m is a prime number p or equal to a power of p .

IV. If m resolved into prime factors is of the form $m = p_1^{\nu_1} p_2^{\nu_2} \dots p_k^{\nu_k}$ and m_0 denotes the product $p_1 p_2 \dots p_k$, then

$$F_m(x) = F_{m_0}\left(x^{\frac{m}{m_0}}\right)$$

From this proposition it follows that in order to find a definite

expression for the polynomial $F_m(x)$, we need only consider the case that m has no square divisors, and a further limitation is still possible. In fact, when m having a single factor 2 is equal to $2n$ we have

$$F_{2n}(x) = \frac{F_n(x^2)}{F_n(x)} = F_n(-x),$$

and thus the construction of the primitive divisor in general is made to depend on the case that m is a product of unequal odd prime numbers.

V. Let p be a prime number not dividing the integer n and $m = pn$, then

$$F_m(x) - 1 \text{ is divisible by } x^{p-1} - 1,$$

when n is not a factor of $p-1$.

On the contrary, when $p-1 = kn$

$$F_m(x) - 1 \text{ is divisible by } \frac{x^{p-1} - 1}{F_n(x)}$$

and

$$F_m(x) - p \text{ is divisible by } F_n(x).$$

VI. Let p be a prime number not dividing the integer n and $m = pn$, then

$$F_m(x) - x^{p\tau(n)} \text{ is divisible by } x^{p+1} - 1,$$

when n is not a factor of $p+1$.

On the contrary, when $p+1 = kn$

$$F_m(x) - x^{p\tau(n)} \text{ is divisible by } \frac{x^{p+1} - 1}{F_n(x)}$$

and

$$F_m(x) + px^{p\tau(n)} \text{ is divisible by } F_n(x).$$

VII. The sum of the roots x_i of the primitive divisor $F_m(x)$ is equal to $\mu(m)$.

VIII. Denoting by D the greatest common measure of the integers k and m and supposing m to have no square divisors the sum of the k^{th} powers of the roots x_i is equal to

$$\mu(m) \mu(D) \varphi(D).$$

From the known values of the sums $\sum x_i^k$, $k = 1, 2, 3, \dots$ the coefficients A_k of the polynomial

$$F_m(x) = A_0 + A_1x + A_2x^2 + \dots + A_Mx^M$$

might be calculated, but we may proceed in a slightly different way.

Supposing m to be a product of unequal odd prime numbers the integers r less than m and prime to m may be arranged into two

groups according as the LEGENDRE symbol $\left(\frac{v}{m}\right)$ has the value $+1$ or -1 . This implies an arrangement of the roots of $F_m(x)$. We have the roots $u = e^{\frac{2\pi ic}{m}}$, where $\left(\frac{c}{m}\right) = +1$ and an equal number of roots $u' = e^{\frac{2\pi i c'}{m}}$, where $\left(\frac{c'}{m}\right) = -1$.

Now by proposition VIII we have

$$\sum_u u^k + \sum_{u'} u'^k = \mu(m) \mu(D) \varphi(D),$$

but at the same time we infer from GAUSS's theorem

$$\sum_u u^k - \sum_{u'} u'^k = \left(\frac{k}{m}\right) i^{\frac{1}{4}(m-1)^2} \sqrt{m}.$$

Hence the sums $\sum_u u^k$ and $\sum_{u'} u'^k$ may be calculated separately and if we introduce the conjugate (real or complex) irrationalities

$$\eta = \frac{1}{2} \left\{ \mu(m) + i^{\frac{1}{4}(m-1)^2} \sqrt{m} \right\},$$

$$\eta' = \frac{1}{2} \left\{ \mu(m) - i^{\frac{1}{4}(m-1)^2} \sqrt{m} \right\},$$

it will be found that there exists a polynomial $f_m(x, \eta) = \prod_u (x - u)$, linear in η with real integer coefficients, having the roots u and also a quite similar conjugate polynomial $f'_m(x, \eta') = \prod_{u'} (x - u')$, having the roots u' .

As obviously

$$F_m(x) = f_m(x, \eta) \times f'_m(x, \eta')$$

it appears that by adjoining the irrationality η to the set of real integers the polynomial $F_m(x)$ has become decomposable.

The values of $\sum_u u^k$ and $\sum_{u'} u'^k$ for $k=1, 2, 3, \dots, \frac{M}{2}$ being calculated, it would be possible to find the coefficients of either of the polynomials $f_m(x, \eta)$ and $f'_m(x, \eta')$, but I will only apply GAUSS's theorem to deduce a tolerably regular expression for their product $F_m(x)$.

If we substitute for x successively the roots u and u' in the identity

$$x^n F_m(x) = \sum_{h=0}^{h=M} A_h x^{h+n},$$

the application of the theorem gives at once

$$0 = \sum_u w^n F_m(u) - \sum_{u'} w'^n F_m(u') = i^{\frac{1}{4}(m-1)^2} \sqrt{m} \sum_{h=0}^{h=M} A_h \binom{k+n}{m},$$

and hence

$$\sum_{h=0}^{h=M} A_h \binom{h+n}{m} = 0.$$

From this relation we obtain taking n equal to $0, -1, -2, \dots, -M+1$ a set of M equations from which the ratios of the coefficients A_h can be solved. In fact, these M equations must be mutually independent, because they are equivalent to the ordinary NEWTON and WARING relations between the coefficients of an algebraic equation and the sums of similar powers of roots.

Joining to the M equations the equation

$$F_m(x) = \sum_{h=0}^{h=M} A_h x^h,$$

we may eliminate the coefficient A_h and introducing a determinate constant C we shall find

$$C \times F_m(x) = \begin{vmatrix} 1 & x & x^2 & x^3 & \dots & x^{M-1} & x^M \\ 0 & \binom{1}{m} & \binom{2}{m} & \binom{3}{m} & \dots & \binom{M-1}{m} & \binom{M}{m} \\ \binom{-1}{m} & 0 & \binom{1}{m} & \binom{2}{m} & \dots & \binom{M-2}{m} & \binom{M-1}{m} \\ \binom{-2}{m} & \binom{-1}{m} & 0 & \binom{1}{m} & \dots & \binom{M-3}{m} & \binom{M-4}{m} \\ \dots & \dots & \dots & \dots & \dots & \dots & \dots \\ \binom{-M+1}{m} & \binom{-M+2}{m} & \binom{-M+3}{m} & \binom{-M+4}{m} & \dots & 0 & \binom{1}{m} \end{vmatrix}.$$

Observing that the term x^M in $F_m(x)$ has the coefficient $+1$, the constant C is readily determined as a symmetric or as a skew symmetric determinant.

As we already remarked proposition VIII in itself suffices to calculate the coefficients A_h and it is evident that in this way there might be deduced a second determinant also representing $F_m(x)$. To obtain this second determinant we have only to replace everywhere in the first the symbols $\binom{k}{m}$ and $\binom{-k}{m}$ by $\mu(D) \varphi(D)$, when D is the greatest common measure of k , and m , taking $D=m$ for $k=0$, and it is rather remarkable that notwithstanding the dissimilar character of the elements of these determinants both represent one and the same polynomial.

If m is prime, we have $M = m - 1$ and the determinant representing $F_m(x)$ by adding to the first column all the other ones is immediately reduced to the polynomial $1 + x + x^2 + \dots + x^{m-1}$. In the general case the coefficients of $F_m(x)$ are not of so simple a character as perhaps might be presumed. Only two of them, the coefficients A_1 and A_{M-1} , take the simple value $-\mu(m)$ and therefore I may end with the proposition

IX. If m is the product of unequal odd prime factors, then

$$\mu(m) \times \begin{vmatrix} 0 & \left(\frac{1}{m}\right) & \left(\frac{2}{m}\right) & \dots & \left(\frac{M-1}{m}\right) \\ \left(\frac{-1}{m}\right) & 0 & \left(\frac{1}{m}\right) & \dots & \left(\frac{M-2}{m}\right) \\ \left(\frac{-2}{m}\right) & \left(\frac{-1}{m}\right) & 0 & \dots & \left(\frac{M-3}{m}\right) \\ \dots & \dots & \dots & \dots & \dots \\ \left(\frac{-M+1}{m}\right) & \left(\frac{-M+2}{m}\right) & \left(\frac{-M+3}{m}\right) & \dots & 0 \end{vmatrix} = \begin{vmatrix} 0 & \left(\frac{1}{m}\right) & \left(\frac{2}{m}\right) & \dots & \left(\frac{M-2}{m}\right) & \left(\frac{M}{m}\right) \\ \left(\frac{-1}{m}\right) & 0 & \left(\frac{1}{m}\right) & \dots & \left(\frac{M-3}{m}\right) & \left(\frac{M-1}{m}\right) \\ \left(\frac{-2}{m}\right) & \left(\frac{-1}{m}\right) & 0 & \dots & \left(\frac{M-4}{m}\right) & \left(\frac{M-2}{m}\right) \\ \dots & \dots & \dots & \dots & \dots & \dots \\ \left(\frac{-M+1}{m}\right) & \left(\frac{-M+2}{m}\right) & \left(\frac{-M+3}{m}\right) & \dots & \left(\frac{-1}{m}\right) & \left(\frac{1}{m}\right) \end{vmatrix}$$

Thus it is shown that the symbol $\mu(m)$ is expressible by LEGENDRE symbols only.

Pathology. — “*On passive immunisation against tetanus.*” By Prof. Dr. C. H. H. SPONCK and WILHELMINA HAMBURGER, Arts.

(Communicated in the meeting of November 25, 1916).

As known, the injection of a heterologous serum not seldom causes symptoms of disease, and experience teaches us, that the injection of a large quantity of serum oftener causes the so-called serum disease than the injection of a smaller quantity. Hence the endeavours of the serum institutes to produce an immune serum with high titre, so that the injection of a small quantity of serum

will be sufficient. For the same reason in some countries a minimum titre has been prescribed by law for a few sera. In Germany e.g. it has been fixed by law that antitetanus serum has to contain at least 4, diphtheria serum at least 500 antitoxic units (A.U.) in one c.c. serum.

As, regarding the possibility that also our country might be drawn into the war, great quantities of antitetanus serum had to be produced, to immunize the wounded against tetanus, the question rose, whether indeed there are sufficient reasons to refuse an antitetanus serum that contains less than 4 A.U. in 1 c.c. for this purpose.

The research we have made to answer this question, has given a surprising result. For it has become clear to us, that the cheaper anti-tetanus serum with a titre of 2 A.U. is not only fit to immunize the wounded, but that it is even to be preferred for this purpose to the much more expensive product with a titre of 4 A.U.

Whilst in the beginning of the European war many died of tetanus, this dreaded wound-disease has now, so to say, entirely disappeared, thanks to the prophylactic injection of 20 antitoxic units into each wounded man. At present little is known about the titre of the antitetanus serum, which is used in the warfaring countries for prophylactic inoculations. Referring to Germany however, we have been told, that they inject serum of 4 A.U. as well as serum of 2 A.U. When there came a shortness of tetanusantitoxine of 4 A.U., the German Government also allowed the injection of a serum with a titre of 2 A.U.

According to theoretical considerations we had come to the supposition, that the passive immunity caused by the injection of 20 A.U. in 10 c.c., is not quite identic to the injection of 20 A.U. in 5 c.c., as in the latter case the inoculated antitoxine might disappear sooner out of the organism than in the former case.

It is not to be doubted, that the injection of horse serum causes the development of antibodies, which attack the horse serum and destroy it. Hence that from the 5th till 7th day after the injection, when in the mean time a certain quantity of antibodies has been produced, the horse serum and also the antitoxine for an important part disappear out of the blood, as DEHNE and HAMBURGER¹⁾ demonstrated. That the tetanus antitoxine and the horse albumen disappear out of the blood at the same time, is referred by these researchers to the fact, that the antitoxine is chemically united to the horse albumen.

After the 5th till 7th day a certain quantity of antitoxine and

¹⁾ Wiener klin. Wochenschrift 1904 and 1905.

horse albumen may remain circulating in the blood for a longer or shorter time.

According to LEMAIRE,¹⁾ who investigated how long the horse albumen can be shown in the blood of children that received an injection of diphtheria serum, also produced by horses, this albumen remains present for at least 10, and at most 50 days.

That horse albumen remains circulating longer in one individual than in another, is referred until now to the fact that the production of antibodies individually differs a great deal. The more antibodies the organism produces, the sooner the horse albumen will disappear out of the body.

According to our supposition a second factor is of influence upon this, namely the *quantity* of horse serum.

We have experimentally proved the rightness of this supposition in the following way:

Two goats of about the same age and size, got each one subcutaneous injection of antitetanus serum, which we had obtained from horses and accurately tested. One goat (**A**) got 80 A.U. (BEHRING-EHRLICH) in 20 c.c. serum, the other (**B**) 80 A.U. in 40 c.c. serum. Afterwards both goats have been bled four times, namely on the 10th, 17th, 24th and 31st day after the inoculation. With the serum with which these bleedings supplied us, a great number of experiments have been taken on white mice, to determine, if the antitoxine disappeared sooner out of the blood of goat **A** than of goat **B**.

Every time increasing doses of goat serum were administered subcutaneously into series of mice under the skin of the back. Exactly after 24 hours these mice and also a control-mouse got a lethal dosis of tetanustoxine under the skin of the left hind-leg, which killed the control-mouse regularly in 3 days. This constant toxic action has been reached by using a tetanustoxine, filtered through a CHAMBERLAND filter, precipitated by means of sulfas ammoniae and dried in vacuo; from this toxine every time 50 m.g. was taken for each experiment, dissolved in 10 c.c. physiological salt solution; from this, a hundred times diluted solution, 0.3 c.c. has been injected into each mouse.

The sera we got from the first bleeding, proved to act equally immunizing. Those from the second bleeding (17 days after the inoculation) on the contrary, did not show any more an equal immunizing action (see experiment n° 1).

Also 24 days after the injection the serum of both goats still

¹⁾ Thèse de doctorat. Paris 1907.

EXPERIMENT N^o. 1

Goat A.				Goat B.			
Mouse	Date	Subcut	Result	Mouse	Date	Subcut.	Result
N ^o . 411	11 Sept. '16	0.2 c.c. serum		N ^o . 414	11 Sept.	0.2 c.c. serum	
	12 "	0.3 c.c. toxine			12 "	0.3 c.c. toxine	
	13 "		no symptoms		13 "		no symptoms
	14 "		local tetanus		14 "		local tetanus
	15 "		local tetanus		15 "		local tetanus
	16 "		dead		16 "		lives
N ^o . 412	11 Sept.	0.3 c.c. serum		N ^o . 415	11 Sept.	0.3 c.c. serum	
	12 "	0.3 c.c. toxine			12 "	0.3 c.c. toxine	
	13 "		local tetanus		13 "		no symptoms
	14 "		local tetanus		14 "		no symptoms
	15 "		local tetanus		15 "		no symptoms
	16 "		lives		16 "		no symptoms
N ^o . 413	11 Sept.	0.4 c.c. serum		N ^o . 416	11 Sept.	0.4 c.c. serum	
	12 "	0.3 c.c. toxine			12 "	0.3 c.c. toxine	
	13 "		no symptoms		13 "		no symptoms
	14 "		local tetanus		14 "		no symptoms
	15 "		local tetanus		15 "		no symptoms
	16 "		lives		16 "		no symptoms

CONTROL.

Mouse	Date	Subcut.	Result
N ^o . 417	12 Sept.	0.3 c.c. toxine	
	13 "		local tetanus
	14 "		dying
	15 "		dead

EXPERIMENT N^o. 2.

Goat A.				Goat B			
Mouse	Date	Subcut.	Result	Mouse	Date	Subcut.	Result
N ^o . 431	22 Sept.	1.6 c.c. serum		N ^o . 434	22 Sept	0.8 c.c. serum	
	23 "	0.3 c.c. toxine			23 "	0.3 c.c. toxine	
	24 "		local tetanus		24 "		local tetanus
	25 "		dead		25 "		local tetanus
	26 "				26 "		local tetanus
	27 "				27 "		lives
N ^o . 432	22 Sept.	1.8 c.c. serum		N ^o . 435	22 Sept	0.9 c.c. serum	
	23 "	0.3 c.c. toxine			23 "	0.3 c.c. toxine	
	24 "		no symptoms		24 "		local tetanus
	25 "		local tetanus		25 "		local tetanus
	26 "		local tetanus		26 "		local tetanus
	27 "		dead		27 "		lives
N ^o . 433	22 Sept.	2.0 c.c. serum		N ^o . 436	22 Sept.	1.0 c.c. serum	
	23 "	0.3 c.c. toxine			23 "	0.3 c.c. toxine	
	24 "		no symptoms		24 "		no symptoms
	25 "		local tetanus		25 "		no symptoms
	26 "		local tetanus		26 "		no symptoms
	27 "		dead		27 "		no symptoms

CONTROL.			
Mouse	Date	Subcut.	Result
N ^o . 437	23 Sept	0.3 c.c. toxine	
	24 "		local tetanus
	25 "		dead

showed a distinctly immunizing action, but the serum of goat **B** a twice as great action as the serum of goat **A** (see experiment n° 2).

Comparing the sera got 31 days after the injection, the immunizing action of the serum of goat **B** still proved to surpass that of goat **A** distinctly.

It would have been clearer, if we had been able to inject twice as much serum of goat **A** as of goat **B**. But in the mean time the immunizing action of the serum of goat **A** had declined in such a way, that the quantity to be inoculated became too large to be injected into mice (see experim. N°. 3).

E X P E R I M E N T N°. 3.

Goat A.				Goat B.			
Mouse	Date	Subcut.	Result	Mouse	Date	Subcut.	Result
N°. 438	25 Sept.	2.0 c.c. serum		N°. 439	25 Sept.	2.0 c.c. serum	
	26 „	0.3 c.c. toxine			26 „	0.3 c.c. toxine	
	27 „		local tetanus		27 „		no symptoms
	28 „		general „		28 „		no symptoms
	29 „		dead		29 „		no symptoms
	30 „				30 „		no symptoms
CONTROL							
	Mouse	Date	Subcut.	Result			
	N°. 440	26 Sept.	0.3 c.c. toxine				
		27 „		local tetanus			
		28 „		dying			
		29 „		dead			

As we had to consider the possibility that the immunity of goat **B** did last longer because this animal was less fit to produce antibodies against horse albumen than goat **A**, we have repeated the experiment on two other goats.

We chose again two goats of about the same age and size, and injected subcutaneously into goat **C** 80 A.U. in 20 c.c. serum, into goat **D** 80 A.U. in 40 c.c. serum. At the 10th, 17th, 24th and 31st

EXPERIMENT N^o. 4.

Goat C.				Goat D.			
Mouse	Date	Subcut.	Result	Mouse	Date	Subcut.	Result
N ^o . 448	20 Oct.	0.2 c.c. serum		N ^o 451	20 Oct.	0.2 c.c. serum	
	21 "	0.3 c.c. toxine			21 "	0.3 c.c. toxine	
	22 "		local tetanus		22 "		no symptoms
	23 "		local tetanus		23 "		no symptoms
	24 "		local tetanus		24 "		slight loc.tetan.
	30 "		dying		25 "		slight loc.tetan.
N ^o . 449	20 Oct.	0.3 c.c. serum		N ^o 452	20 Oct.	0.3 c.c. serum	
	21 "	0.3 c.c. toxine			21 "	0.3 c.c. toxine	
	22 "		local tetanus		22 "		no symptoms
	23 "		local tetanus		23 "		no symptoms
	24 "		local tetanus		24 "		no symptoms
	30 "		dying		25 "		no symptoms
N ^o . 450	20 Oct.	0.4 c.c. serum		N ^o . 453	20 Oct.	0.4 c.c. serum	
	21 "	0.3 c.c. toxine			21 "	0.3 c.c. toxine	
	22 "		local tetanus		22 "		no symptoms
	23 "		local tetanus		23 "		no symptoms
	24 "		local tetanus		24 "		no symptoms
	30 "		lives		25 "		no symptoms

CONTROL.

Mouse	Date	Subcut.	Result
N ^o . 454	21 Oct.	0.3 c.c. toxine	
	22 "		local tetanus
	23 "		dead

EXPERIMENT No. 5.

Goat C.				Goat D.			
Mouse	Date	Subcut.	Result	Mouse	Date	Subcut.	Result
No. 455	27 Oct.	1.6 c.c. serum		No. 458	27 Oct.	0.8 c.c. serum	
	28 "	0.3 c.c. toxine			28 "	0.3 c.c. toxine	
	29 "		local tetanus		29 "		local tetanus
	30 "		dying		30 "		local tetanus
	31 "		dead		31 "		local tetanus
	1 Nov.			1 Nov.		lives	
No. 456	27 Oct.	1.8 c.c. serum		No. 459	27 Oct.	0.9 c.c. serum	
	28 "	0.3 c.c. toxine			28 "	0.3 c.c. toxine	
	29 "		local tetanus		29 "		local tetanus
	30 "		dying		30 "		local tetanus
	31 "		dead		31 "		local tetanus
	1 Nov.			1 Nov.		lives	
No. 457	27 Oct.	2.0 c.c. serum		No. 460	27 Oct.	1.0 c.c. serum	
	28 "	0.3 c.c. toxine			28 "	0.3 c.c. toxine	
	29 "		local tetanus		29 "		no symptoms
	30 "		local tetanus		30 "		no symptoms
	31 "		dead		31 "		no symptoms
	1 Nov.			1 Nov.		no symptoms	

CONTROL.

Mouse	Date	Subcut.	Result
No. 461	28 Oct.	0.3 c.c. toxine	
	29 "		local tetanus
	30 "		dying
	31 "		dead

EXPERIMENT N^o. 6.

Goat C.				Goat D.			
Mouse	Date	Subcut.	Result	Mouse	Date	Subcut.	Result
N ^o . 462.	3 Nov.	2.0 c.c. serum	local tetanus dead	N ^o . 464	3 Nov.	2.0 c.c. serum	no symptoms no symptoms no symptoms no symptoms
	4 "	0.3 c.c. toxine			4 "	0.3 c.c. toxine	
	5 "				5 "		
	6 "				6 "		
	7 "				7 "		
	8 "				8 "		
N ^o . 463	3 Nov.	2.0 c.c. serum	local tetanus dying dead	N ^o . 465	3 Nov.	2.0 c.c. serum	no symptoms no symptoms no symptoms no symptoms
	4 "	0.3 c.c. toxine			4 "	0.3 c.c. toxine	
	5 "				5 "		
	6 "				6 "		
	7 "				7 "		
	8 "				8 "		
CONTROL.							
Mouse	Date	Subcut.	Result				
N ^o . 466	4 Nov.	0.3 c.c. toxine	local tetanus dead				
	5 "						
	6 "						

day after the immunization both goats were bled and the anti-toxic potency of their serum was compared.

As it appears from the experiments 4, 5, and 6, the results were quite conformable to those we got for goats A and B.

The result of the experiments mentioned above, shows clearly that, to fix the dosis of an immune serum which has to be injected to acquire an immunity of a certain degree and duration, *not only attention has to be paid to the titre of the serum, as now generally happens, but also to the quantity.* The quantity may not be chosen too small, because the organism defends itself against the heterolo-

gous serum and is easily able to destroy a small quantity in a few days, even if the titre is very high.

To obtain an immunity for a longer time, a quantity of serum has to be injected, which the organism, even if it defends itself vigorously against the foreign serum, cannot destroy too soon. The disadvantage that is attached to the injection of a large quantity of serum, namely the developing of symptoms of serum disease, which are always temporary, is not of great importance when a perilous illness is to be prevented.

Relating to the passive immunization of the wounded against tetanus, which gave rise to our research, we came therefore to the conclusion that there is absolutely no cause to use for this purpose, as now commonly happens in our country, an antitetanus serum that contains in one c.c. 4 A.U.

The injection of 10 c.c. antitetanus serum with a titre of 2 A.U. deserves to be preferred, because in this way, an equal degree of immunity is produced as by injection of 5 c.c. antitetanus serum of 4 A.U., and the immunity lasts longer.

Moreover, the results of our experiments give an important indication concerning the immunization against diphtheria. Years ago, when in all countries diphtheria serum was used with a titre of about 100 A.U., it has been fixed empirically that the injection of 5 c.c. serum (= 500 A.U.) was sufficient to protect a child against diphtheria for about 3—4 weeks. Afterwards in some countries the titre of the diphtheria serum has been raised more and more. If now, — relying on the false supposition, that the duration of the immunity has nothing to do with the quantity of serum that is inoculated —, to prevent diphtheria, 1 c.c. diphtheria serum with a titre of 500 A.U. is injected into a child, expecting to get in this way the same result as formerly with the injection of 5 c.c. with a titre of 100 A.U., there is a great chance that the immunity, instead of 3 or 4 weeks, only lasts 1 week.

Chemistry. — “*On the Allotropy of the Ammonium Halides*”. III¹⁾.

By Dr. F. E. C. SCHEFFER. (Communicated by Prof. P. ZEEMAN.)

(Communicated in the meeting of Nov. 25, 1916).

§ 14. In § 1 I said that in the older literature statements occur which point to the occurrence of two different modifications of ammonium bromide and ammonium chloride, and that it has been demonstrated in a paper by WALLACE that ammonium bromide is

¹⁾ First paper. These Proc. XVIII p. 446. Second paper. These Proc. XVIII p. 1498.

enantiotropic. According to WALLACE's determinations the transition point lies at 109° . As it has, however, appeared to me when I repeated the experiments with ammonium chloride that the value that WALLACE gives, is considerably too low, I have determined the transition point of ammonium bromide in the same way as in the first paper. I already announced these experiments in my first paper in § 8, and I communicated the preliminary result that ammonium bromide possesses a transition point at 137° at the Natuur- en Geneeskundig Congres in April 1915¹⁾. I have, however, been obliged to postpone the full description of these experiments till now.

In 1916 there appeared two papers by SMITH and EASTLACK; in the former²⁾ they communicate that they discontinued the determination of the transition point of ammonium chloride at the publication of my first paper, but that they have continued the experiments with ammonium bromide. Their conclusion derived from determinations of the solubility in water is that the transition point lies at $137^{\circ}.3$. In the latter paper³⁾ it is stated that ammonium iodide does not possess a transition point between -19° and 136° .

In what follows I will briefly give the results of my investigation with ammonium bromide, which as appears from the above mentioned preliminary communication, agree with those of SMITH and EASTLACK, and those of ammonium iodide, which have yielded the transition point, which had not been found up to now.

The result obtained with ammonium iodide, has already been published by Mr. HOOGENBOOM in his Thesis for the Doctorate.⁴⁾

15. *Thermal determination of the transition point of ammonium bromide.*

The experiments described in §§ 15—18 have been carried out with ammonium bromide prepared from hydrogen bromide and ammonia. Hydrogen bromide was obtained by leading purified bromine (method MEERUM TERWOGT⁵⁾) with hydrogen over heated platinum; ammonia was obtained by fractionating liquid ammonia obtained from ammonia liquida and leading it into water.

When we try to determine the transition point of ammonium bromide in the well-known way through curves of heating and cooling, it appears that the conversion of the two modifications into

¹⁾ Handelingen van het 15e Ned. Nat. en Gen. Congr. (April 1915) p. 242 e.seq.

²⁾ Journ. Amer. Chem. Soc. **38**, 1261, (1916).

³⁾ Journ. Amer. Chem. Soc. **38**, 1500, (1916).

⁴⁾ Dissertatie Amsterdam (July 1916), p. 64 and 65.

⁵⁾ Dissertatie Amsterdam (Nov. 1904), p. 6 et seq.

each other goes so slowly that the temperature which remains constant is found much higher for heating than for cooling.

The limits found in this way for the transition point, are $\pm 124^\circ$ and 147° . The distance between them is, therefore, still greater than for ammonium chloride. (Cf. § 3).

The velocity of conversion can, however, just as for ammonium chloride, be increased by the addition of glycerine. (Cf. § 6). The limits between which the transition point must lie, are reduced in this case to $137^\circ.3$ and $139^\circ.5$. Hence also with the catalyzer the distance remains greater than for ammonium chloride. Experiments with glycol as catalyzer yielded $137^\circ.3$ and $140^\circ.1$.

16. Vapour pressure measurements.

I have determined the vapour tensions of the saturated solutions in an apparatus of the form as described by LEOPOLD¹⁾. No more than for NH_4Cl does the transition point express itself in the vapour

T A B L E 11.

t	p	$10^3 T^{-1}$	$\log p$	t (calc.)	Error	Series
98.1	43.1	2.6947	1.6345	98.0	+ 0.1	I
110.3 ⁵	63.6	2.6086	1.8035	110.5	- 0.1 ⁵	I
116.7 ⁵	76.6 ⁵	2.5657	1.8845	116.7 ⁵	0	I
126.0	99.8	2.5063	1.9991	126.0	0	I
128.8	107.9	2.4888	2.0330	128.8	0	II
129.3	109.1	2.4857	2.0378	129.2	+ 0.1	III
134.7	125.8	2.4528	2.0997	134.5	+ 0.2	II
136.3	131.8	2.4432	2.1199	136.2 ⁵	+ 0.0 ⁵	I
141.0	149.5	2.4155	2.1746	141.0 ⁵	- 0.0 ⁵	I
144.0	161.2	2.3981	2.2074	144.0	0	III
147.2	174.9	2.3798	2.2428	147.2	0	II
147.4 ⁵	175.8	2.3784	2.2450	147.4	+ 0.0 ⁵	I
147.8	176.8	2.3764	2.2475	147.6	+ 0.2	II
153.4	204.0	2.3452	2.3096	153.4	0	I
153.9	206.4	2.3424	2.3147	153.9	0	III
154.8	210.3	2.3375	2.3228	154.6 ⁵	+ 0.1 ⁵	II
157.5	225.2	2.3229	2.3526	157.5	0	I

¹⁾ Dissertatie Amsterdam (Sept. 1906), p. 64 et seq.

tension curves, though the pressure measurement could take place here with greater accuracy. The values which were found for the vapour tensions (in cm. of mercury) with three different fillings, and which were used for the calculations of § 17, have been combined in table 11 (p. 800). If in a graphical representation we draw $\log p$ as function of T^{-1} , one straight line can be drawn through the found points. A break is not to be found, though the pressure in the neighbourhood of the transition point has been determined with an accuracy of 1 or 2 ‰. As appears from table 11 the vapour tension line can be represented by the formula:

$$\log p = -\frac{1927.6}{T} + 6.8302.$$

17. *Determinations of the solubility of ammonium bromide in water for temperatures between 95° and 158°.*

The experiments were executed in the way described in § 5. The data are combined in table 12 (p. 802); x represents the number of molecules of NH_4Br , present in one molecule of the mixture, and is therefore determined by:

$$x = \frac{\frac{g}{M_{\text{NH}_4\text{Br}}}}{\frac{g}{M_{\text{NH}_4\text{Br}}} + \frac{100}{M_{\text{H}_2\text{O}}}} = \frac{g}{g + 543.7}$$

In fig. 7. the values are drawn of $\log x$ and T^{-1} . The values below the transition point appear to lie on a smooth curve with a faint curvature; the curve is convex seen from below; through the points in the neighbourhood of the transition point, however, the straight line can be drawn given by the equation:

$$\log x = -\frac{372.7}{T} + 0.31978.$$

The points above the transition point lie on the line:

$$\log x = -\frac{293.7}{T} + 0.12727.$$

The concordance between the values calculated from these lines and the observations is satisfactory as appears from table 13. (Error 1 ‰ or smaller.)

The two straight lines indicated above yield for the point of intersection:

$$t = 137.4^\circ.$$

51*

T A B L E 12.
Melting points of the solid substance in $\text{NH}_4\text{Br}-\text{H}_2\text{O}$ mixtures.
 $M_{\text{NH}_4\text{Br}} = 97.96$; $M_{\text{H}_2\text{O}} = 18.016$.

No.	Weight		t	Weight water in vapour	Weight water (corr.)	Grammes NH_4Br in 100 Grs H_2O (g)	$-\log x$	$10^3 T^{-1}$
	NH_4Br	H_2O						
1	2505.0	1791.6	94.95	0.2	1791.4	139.84	0.68913	2.7178
2	3091.5	2038.6	106.25	0.2	2038.4	151.66	0.66134	2.6368
3	3155.6	2019.5	110.4	0.5	2019.0	156.29	0.65116	2.6083
4	3195.0	1886.2	121.8	0.4	1885.8	169.42	0.62420	2.5329
5	3275.7	1852.3	128.0	0.7	1851.6	176.91	0.60995	2.4938
6	3346.3	1850.0	131.1	0.9	1849.1	180.97	0.60255	2.4746
7	3647.4	1967.2	134.6	0.6	1966.6	185.46	0.59457	2.4534
8	3410.5	1800.7	137.65	1.0	1799.7	189.50	0.58761	2.4352
9	4342.9	2241.4	142.05	0.4	2241.0	193.79	0.58043	2.4094
10	4220.7	2147.5	144.75	1.0	2146.5	196.63	0.57578	2.3938
11	3318.4	1665.1	147.65	1.2	1663.9	199.43	0.57127	2.3773
12	3802.8	1885.8	149.7	1.3	1884.5	201.79	0.56754	2.3658
13	4342.4	2121.7	152.6	1.0	2120.7	204.76	0.56292	2.3496
14	3746.0	1779.6	157.95	1.4	1778.2	210.66	0.55401	2.3204

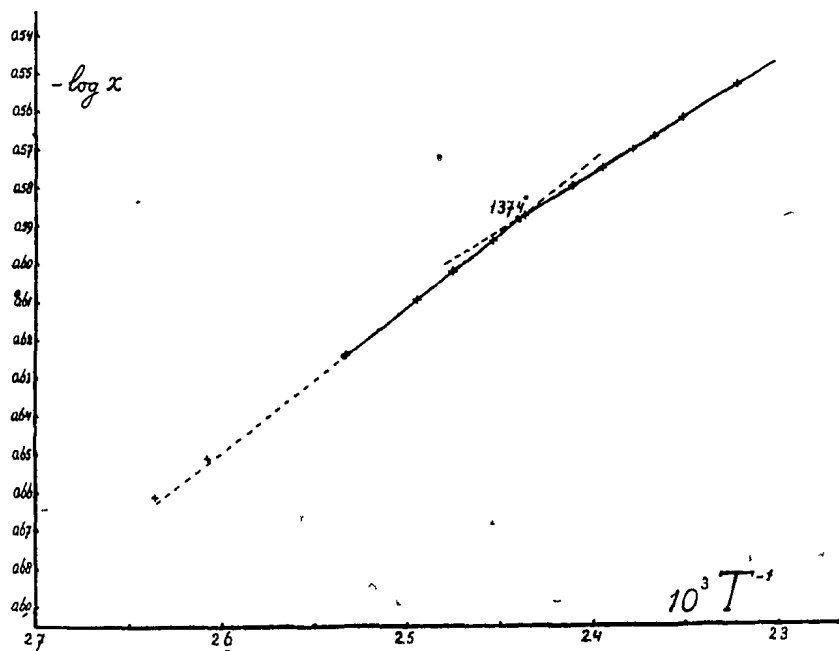

Fig. 7.

T A B L E 13.

N ^o	<i>t</i>	Number of grammes NH ₄ Br to 100 Grammes of H ₂ O		error
		calculated	found	
4	121.8	169.4 ^o	169.4 ^o	+ 0.0 ²
5	128.0	177.0 ⁶	176.9 ¹	- 0.1 ⁵
6	131.1	180.9 ⁸	180.9 ⁷	- 0.0 ¹
7	134.6	185.4 ⁴	185.4 ⁶	+ 0.0 ²
8	137.6 ⁵	189.3 ⁹	189.5 ⁰	+ 0.1 ¹
8	137.6 ⁵	189.3 ¹	189.5 ⁰	+ 0.1 ⁹
9	142.0 ⁵	193.8 ³	193.7 ⁹	- 0.0 ⁴
10	144.7 ⁵	196.6 ³	196.6 ³	0
11	147.6 ⁵	199.6 ⁵	199.4 ³	- 0.2 ²
12	149.7	201.7 ⁹	201.7 ⁹	0
13	152.6	204.8 ³	204.7 ⁶	- 0.0 ⁷
14	157.9 ⁵	210.4 ⁹	210.6 ⁶	+ 0.1 ⁷

This value for the transition point can, in my opinion, only deviate a few tenths of degrees from the real value.

18. It can be derived from the results of §§ 15 and 17 that the transition point of ammonium bromide lies at **137.4°**, a value which within the errors of observation agrees with the value found by SMITH and EASTLACK. In the thermal determinations the retardation on cooling appears to have been destroyed by the catalyzers glycerine and glycol, in case of rising temperature some retardation continues to exist in spite of the catalyzer.

19. *Thermal determination of the transition point of ammonium iodide.*

I have succeeded in demonstrating the existence of a transition point of ammonium iodide unknown up to now by thermal experiments.

In these experiments the same difficulty presents itself as for NH₄Cl and NH₄Br. On cooling a value is again found that lies lower than that which is found from the curves of heating. For my experiments I used a preparation of SCHLIERING, which as appears from the analysis (expulsion of iodine by NaNO₂ and H₂SO₄)

contained only 0.1 or 0.2 % NH_4Cl or NH_4Br . Thermal experiments yielded the limits -20° and -14° for the transition point. To bring these limits closer together I have examined whether a small quantity of water is a suitable catalyzer. I have succeeded in reducing the limits to -17.2 and -15.6 . From these experiments I have, therefore, to conclude to a transition point at -16° , a value, which can depart a degree from the accurate one. The eutectic point $\text{NH}_4\text{I}-\text{H}_2\text{O}$ lies at -28° ; I have been able to observe both the occurrence of the eutectic point and of the transition point in one curve of cooling.

I have not yet had an opportunity to determine the transition point more accurately. In the cited paper by SMITH and EASTLACK there have been recorded determinations of the solubility of ammonium iodide; the lowest temperature already lies below the transition point. When these determinations of the solubility are continued towards lower temperatures the break will undoubtedly be clearly perceptible and the value can be determined with greater accuracy than has taken place above by the aid of thermal experiments.

20. *Summary of the results.*

The ammonium halides NH_4Cl , NH_4Br , and NH_4I can all occur in two modifications. The transition points of the two first lie *above*, that of the third *below* the ordinary temperature of the room. At the ordinary temperature $\alpha\text{-NH}_4\text{Cl}$ and $\alpha\text{-NH}_4\text{Br}$ are isomorphous; $\beta\text{-NH}_4\text{I}$ is, however, not continuously miscible with the two others. By the α -form the form is indicated that is stable *below*, by the β -form the form that is stable *above* the transition point. The supposition suggests itself that the α -forms are continuously miscible inter se, and likewise the β -forms, but that between α - and β -forms incomplete mixing always takes place. The succession of the transition points NH_4Cl 184.5° , NH_4Br 137.4° and NH_4I -16° is that which would be expected according to the periodic system.

Postscript during the correction: In Proc. Amer. Acad. of Arts and Sciences 52 91 et seq. (1916) BRIDGMAN calculates from observations at high pressure that the transition points of NH_4Cl , NH_4Br and NH_4I at ordinary pressure must lie at 184.3° , 137.8° , and -17.6° . The first two deviate but little from my determinations; the third value may point to this that the transition point lies at the lower limit of my thermal determinations.

Botany. --- "*Variability of segregation in the hybrid*". By Dr. J. A. HONING. (Communicated by Prof. F. A. F. C. Went).

(Communicated in the meeting of November 25, 1916.)

Most botanists investigating heredity prefer to employ annual plants and endeavour to force biennials to flower in their first year in order to obtain seed, as was done by nearly all investigators of *Oenothera*. Perennials, to say nothing of trees, often require several years before their seedlings bloom, and sometimes they produce but few seeds, so that their use has naturally been less in favour.

The flowering season of annuals is brief, a few months only, and the seed obtained by self pollination of annual hybrids from different fruits is generally sown mixed, on the assumption that the segregation ratios are constant, so that for the ratios of the phenotypes it does not matter much whether seed has been collected from the first fruits or from those matured a month later. Probably this assumption is correct in many cases, perhaps in most, but not in all, as ZEDERBAUER ¹⁾ has shown for *Pisum*.

There is no reason whatever to assume that *Pisum* is unique in this respect and further examples will doubtless be found. The best chance of finding clear cases will be, for annuals, among those with a long flowering season, and further among those perennials, of which one and the same individual can be studied for some years in succession. A tropical climate enabling one to collect seed almost throughout the year, would then be advantageous.

In order to ascertain whether independent Mendelian segregation can take place simultaneously with respect to a number of factors, larger than that of the chromosomes, I crossed in 1913 a variety of *Canna glauca* with one of *C. indica*. The number of genes in which these two differ was — and remains, unknown; it was certainly larger than three, the number of chromosomes in *Canna indica* according to WIEGAND ²⁾ and certainly larger than eight, the actual number of chromosomes, which was already indicated by KOERNICKE ³⁾. A brief description of the two species will make this clear.

¹⁾ ZEDERBAUER, E., Zeitliche Verschiedenwertigkeit der Merkmale bei *Pisum sativum* Ztschr. f. Pflanzenzüchtung II p. 1—26, 1914.

²⁾ Bot. Gaz. T. 30, 1900.

³⁾ Ber. d. d. bot. Ges. XXI. 1903, p. 66 See also Rec. d. trav. bot. Néerl. XII, 1915, p. 23.

Organ	<i>Canna indica</i>	<i>Canna glauca</i>
Stem	<i>tall</i> , about 2 m. stool with few stalks	low about 1 m. stool with many stalks
Leaves	short about 39 cm. <i>broad</i> , about 16 cm. with <i>broad red margin</i> shiny	<i>long</i> about 50 cm. narrow, about 12 cm. green <i>dull</i> , on account of a layer of wax
Staminodes	two dark <i>red</i> short, average 59 m.m. narrow, 8—12 m.m., average 10—8	<i>three</i> pale yellow with a few pink spots <i>long</i> , average 83 m.m. <i>broad</i> 13—20 m.m., aver- age 16—2
Ovary	<i>red</i>	green
Seeds	small round <i>uniformly black</i>	<i>large</i> <i>oblong</i> brown with black speckles

The two plants used for crossing were both F₂ individuals, obtained by repeated self pollination and were similar to their F₁ and P. After repeated failures a single ripe fruit was obtained from the cross *glauca* × *indica*; it contained two seeds, one of which failed, so that the entire F₁ consisted of a single individual, since the reverse crossing was unsuccessful. This one individual was tall, had long, fairly broad leaves, with a red margin and a covering of wax, somewhat orange-red flowers with 3 long, broad staminodes, red ovaries and large, long, black seeds. The dominant characters are printed in italics in the above comparison.

Of the F₂ 1168 seedlings have so far been obtained, of which 867 after artificial pollination and 301 after free pollination, no other *Canna*'s grew in the neighbourhood. Of these 1168 plants a fairly large number died before flowering, so that for many of the characters accurate ratios have perhaps not been found. The deviations from the numbers to be expected in an independent Mendelian segregation are in some cases, however, so considerable, that they cannot possibly be reduced to them, not even on the assumption, that all the dead individuals belonged to the type or types of which there was a shortage. For the present we must say, therefore, that there was hardly any evidence if at all of an independent Mendelian segregation, as will appear from the following discussion of some of the characters.

The red leaf margin.

It was shown in a previous paper ¹⁾ that the difference between the variety of *Canna indica* with a red leaf margin and that with entirely green leaves is one of three hereditary factors. The observed numbers of plants with and without red margin, viz. 95 red as against 127 green and 83 with red edge as against 112 green, agreed very well with the ratio 27: 37 which require, for 222 and 195 individuals respectively 93.6 red: 128.3 green and 82.3 red: 112.7 green. In addition, however, the ratios 3: 1 (45 red: 17 green) and 9: 7 (29 red: 22 green) were found among the offspring of individuals, which must be represented genotypically by AaBbCc, and this points to the coupling of all three factors or at least of two of them. Furthermore all kinds of ratios were observed which defy explanation, as for instance, 63 red. 9 green.

The F₂ of the cross *C. glauca* × *indica* with red leaf margin were sown in seven batches. Segregation according to three independent characters, therefore according to 27: 37, did not occur, but twice the ratio 9: 7 was observed with very slight deviations (nos. 5 and 6) and in three batches (nos 3, 4 and 7) the ratio 1: 1 was unmistakable, in the remaining two lots the ratio approximates most closely to 9: 7, but still differs from it rather considerably. From these two taken together the deviation is small (nos. 1 and 2) See table I.

TABLE I. Segregation of F₂ into individuals with and without a red leaf margin

Sowing	Date	Number of seeds	Number of seedlings	With red margin	Green	Theoretically by segregation according to 9: 7
1	3-9-'14	200	158	83	75	127,1 : 98,9 (actually 126 : 100)
2	28-7-'15	92	68	43	25	
3	19-8-'15	223	202	101	101	
4	29-9-'15	75	60	30	30	
5	15-12-'15	260	233	132	101	131,1 : 101,9
6	30-3-'16	267	232	129	103	130,5 : 101,5
7	17-5-'16	263	215	107	108	
Total		1380	1168	625	543	

¹⁾ HONING, J. A., Kreuzungsversuche mit *Canna*-Varietäten. Rec. d. trav. bot. Néerl. Vol. XII, p 1-26, 1915.

The seeds of sowings 2 and 5 were obtained after free pollination at a time when no other *Canna's* were in flower.

Here therefore the offspring of a single individual is split according to different ratios, whilst there is some suggestion of periodicity. Accidental variations are pretty well excluded on account of the considerable numbers employed. The mean error for segregation according to 9:7 is for 1000 individuals 0.2510 per 16 ¹⁾. Here with 1168 plants, it is 0.4384. For the separate sowings, such as those which separated into 101:101 and 107:108, the differences from the mean errors are much larger still.

There is yet another objection. In the crossing of varieties of *C. indica* it was found that one of the factors for the red leaf margin, C, might be separately visible ²⁾, and indeed in a segregation according to 27:37 exactly as required by the theory, in $37 - 16 = 21$ of the 64 individuals. Such plants with a very narrow red margin were, however, always present in too small a number when the segregation deviated from 27:37. In the cross with *C. glauca* this shortage extends so far that among the 543 green seedlings *not a single one* was found to have a narrow red leaf margin.

For the sowings segregating according to 9:7 on the other hand an explanation is not readily available, for C may be completely coupled to A or B. The ratio 9:7 also points to the complete joining of two of the three factors.

In the cases of segregation according to 1:1 we are *not* concerned with a mixture, formed by segregation according to two different ratios (viz. 9:7 and 27:37) for in that case some of the green seedlings would nevertheless have shown at a later stage that they possessed the factor C.

If we adhere to the assumption that, in this case also, C is completely coupled to A and B, we cannot attribute the displacement of the ratio red:green in favour of green to the coupling of A and B, for in that case the number of individuals with red leaf margin would be increased; we may, however, attribute the changed ratio to repulsion. This repulsion would not even have to go so far as to cause the ratio red:green to approximate to 1:1, for

$$AB - (Ab + aB + ab) = (2n^2 + 1) - [(n^2 - 1) + (n^2 - 1) + 1] = 2.$$

As soon as n , half the sum of the numbers expressing the ratio of the gametes, is 5, 6 or more, the difference 2 is, proportionally, very small. But then also the Ab or aB individuals, amounting to

¹⁾ JOHANNSEN, W., Elemente der exakten Erblichkeitslehre.

²⁾ l.c. b. 18.

nearly 25% of the total. would, with C, have a narrow red leaf margin, and this phaenotype is absent.

The total absence of plants which do not at the same time have both the factors A and B, but have C and ought to be able to show that factor separately also excludes any explanation based on imperfect coupling or repulsion of C with respect to A and B.

Three possibilities still remain: *a.* part of the germ cells die off; *b.* a factor might come into play which prevented the manifestation of C and was itself dependent on the presence of A and B, *c.* with complete coupling of C to A and B unilateral reduplication might occur, as HERIBERT-NILSSON ¹⁾ postulates in some cases for the factor for red leaf veins in *Oenothera Lamarckiana*. Such reduplication would then occur, not, as is supposed in *Oenothera*, in the germ cells which possess this factor, but rather in those which are deficient in the factor C.

Of course the F₂ must be crossed back with the recessive form, for this character therefore with *C. glauca*, and this will take much time. Moreover the same variability in the segregation ratios may be expected as in self-pollination, so that the question will probably not be cleared up much by this.

That the confusion of the Mendelian segregation involving a large number of factors need have no permanent effect on the offspring, is shown by the ratios of some of the F₃ numbers.

TABLE II. Segregation in F₃ for the character of red leaf margin.

F ₂ No.	Number of seeds	Number of seedlings	With red margin	Green	Ratio red : green	Theory
1	70	48	36	12	3 : 1	36 : 12
9	67	49	28	21	9 : 7	27,6 : 21,4

Wax on the leaves.

Whether a definite wax layer is present on the leaves, as in *C. glauca*, or whether it is absent, cannot be determined in young seedlings. Not until 1—1½ months after planting out does the chance of error become small, but even then doubtful individuals remain, which are best judged by subsequently formed shoots.

The number of factors for wax is still unknown; it will most likely become evident in F₃, but then only for these numbers of

¹⁾ HERIBERT-NILSSON, N, Die Spaltungserscheinungen der *Oenothera Lamarckiana*, 1916.

TABLE III. Segregation of F2 into individuals with and without wax layer.

Sowing	Number of plants with wax; of these			Number of plants without wax; of these			Ratios			
	red	green	total	red	green	total	wax: no wax	r:gr	r:gr; originally	r:gr; without wax
1	29	27	56	6	2	8	7,00	1,21	1,11	3,00
2	24	15	39	11	4	15	2,60	1,84	1,72	2,75
3	75	76	151	22	9	31	4,87	1,14	1,00	2,44
4	22	23	45	2	5	7	6,43	0,86	1,00	0,40
5	104	75	179	10	7	17	10,53	1,39	1,31	1,43
6	92	73	165	14	9	23	7,17	1,29	1,25	1,56
7	72	49	121	17	10	27	4,48	1,51	1,01	1,70
Total ...	418	338	756	82	46	128	5,91	1,30	1,15	1,78

which the F2 is considerably less heterozygotic for the other factors than the F1. Clearly, in any case, there was no independent Mendelian segregation for the factors of the wax layer and the ratios in the various batches sown showed even greater divergence than those of red and green. (See tables III).

There is an appreciable repulsion between the factors for the red leaf margin and those for the wax layer. This is best seen by observing how many red and green individuals there are without wax. The number of red ones is then found (except in the fourth sowing) to be the larger, sometimes 2—3 times as large and on the average 1,78 as large as that of the green, whereas the ratio red to green was originally 1,15:1 and was not displaced, through the slightly larger mortality of the green individuals, beyond the ratio 1,30:1.

The number of staminodes.

C. indica has two staminodes. In a few flowers, however, an indication of a third is found in the shape of a red filament, generally not longer than a few millimeters.

C. glauca has always three staminodes. The F1 of the crossing has 3 and the vast majority of F2 also 3.

The number of plants with 2 or 2—3 staminodes varies rather considerably in the different sowings, the last three furnishing many

more than the first four. For plants with two and three staminodes differences in the external conditions might be the cause, but for those with only two this is less likely.

TABLE IV The number of staminodes of the F₂

Sowing	Number of staminodes			
	three	three to four	three to two	two
1	56	6	1	1
2	27	4	2	0
3	131	3	6	0
4	44	0	4	1
5	157	8	9	4
6	113	3	10	1
7	67	6	6	2
Total	595	30	38	9

In a discussion of the colour of the flowers it will be shown that, even apart from the fairly large variation of these figures, no independent Mendelian segregation occurred, since in the first four sowings the individuals with two and with two or three staminodes were out of proportion more numerous among the plants with yellow than among those with red flowers.

The length and breadth of the staminodes.

These differ considerably, in *C. indica* and *C. glauca*. In the former species the length varied from 45—69 mm. and the average was 59,297 mm. calculated from 482 specimens. The breadth was 8—14 mm., the average of 480 flowers 10,808 mm. For *C. glauca* these figures were 70—97 mm. with an average of 87,076 mm. for 435 measurements, and 13—20, average 16,235 mm.

The F₁ had staminodes of length 70—89 mm. average 82,661 mm. and breadth 14—18, average 16,524 mm. The staminodes were therefore a trifle shorter than those of the parent with longest staminodes; there is no appreciable difference in breadth. In comparison with *C. glauca* the extent of variation is very limited, which is no doubt explained by the fact that the F₁ consisted of a single

TABLE V. Length of staminodes.

Species or hybrid	Number of flowers	Limits of variation in mm.	Average	Standard-deviation
<i>C. indica</i>	482	45—69	59,297	3,225
<i>C. glauca</i>	435	70—97	87,076	4,383
F 1	454	70—89	82,661	2,438
F 2, sowing 1	2752	57—95	76,346	6,467
" " 3	620 *)	57—97	76,732	7,097
" " 4	975 **)	56—100	77,277	8,206
" total	4956	56—100	76,449	7,076

TABLE VI. Breadth of staminodes.

Species or hybrid	Number of flowers	Limits of variation in mm.	Average	Standard-deviation
<i>C. indica</i>	480	8—14	10,808	0,728
<i>C. glauca</i>	434	13—20	16,235	1,334
F 1	452	14—18	16,524	0,696
F 2, sowing 1	2748	8—21	14,508	2,050
" " 3	620 *)	8—22	14,429	2,541
" " 4	975 **)	9—21	15,135	2,236
" total	4949	8—23	14,637	2,240

individual, whereas 30 *indica*- and 14 *glauca*-plants were measured.

The figures of F2 are found in tables V and VI. As long as the number of factors has not been determined, the dimensions of the staminodes would not have any importance, if large and small flowers were uniformly distributed between the plants with green leaves and those with red leaf margin. This is, however, not the case. The shortest as well as the longest flowers are found among the green leaved individuals, which therefore have a larger variability.

In table VII is given the number of plants having an average length of the flower of 62—63, 64—65 mm. etc. The limits of variability are for the plants with red leaf margin 66—90 mm., for the green ones 62—96. The difference, 10 mm. is not so very great, but on the other hand the difference in the numbers of

*) 10 flowers per plant.

***) 25 flowers per plant.

TABLE VII. Relation between average length of staminodes and colour of leaves.

Average length in mm.	Plants with red leaf margin. Flowers red.	Leaves green		Total
		Flowers red	Flowers yellow	
62-63	—	1	1	2
64-65	—	—	—	—
66-67	3	2	6	11
68-69	2	2	1	5
	(5)	(5)	(8)	(18)
70-71	2	5	0	7
72-73	10	7	2	19
74-75	13	3	3	19
76-77	12	2	6	20
78-79	7	3	4	14
80-81	5	3	6	14
82-83	5	1	5	11
84-85	11	2	2	15
86-87	7	2	3	12
88-89	1	—	2	3
90-91	1	—	—	1
92-93	—	1	—	1
94-95	—	1	—	1
96-97	—	—	1	1
Total	79	35	42	156

individuals at the two extremes is considerable. There are 18 plants having staminodes of an average length less than 70 mm. and of these only 5 have a red leaf margin. This ratio of red : green, viz. 5 : 13 or 1 : 2.6, differs from the ratio of total reds : total greens, which is 79 : 77 or practically 1 : 1. For plants with an average staminodal length of more than 87 mm. which is that of *C. glauca*, the ratio red margin : green is 2 : 5 = 1 : 2.5 which likewise deviates. We must add that the 5 individuals all had light coloured flowers, viz. 3 yellow and 2 pale red.

Furthermore the large number of small-flowered plants among those with yellow flowers is remarkable, 8 of the 42 or 19,0% show an average of less than 70 mm. For the plants with red flowers the numbers were 10 out of 114 or 8.8%. Among the grandparents it was just the opposite, the small flowers being red and the large ones yellow. If the red-flowered plants are further separated into those with red leaf margin and those without, the green ones comprise in proportion more than double the number of small flowered individuals, namely 5 out of 35 or 14,3% as against 5 out of 79 with red margin, or 6,3%

Colour of the flower

According to the intensity of the red in the flowers of the F₂ five or six different tints may be distinguished. The yellow varies less and not more than three shades can be clearly recognized. Between these there are a number of orange colours, so that the determination of the number of factors for red will not be easy. (See table VIII).

The proportion of the numbers of plants with red and yellow flowers varies from 2.1 · 1 to 4.79 · 1 and the same proportion for the green leaved individuals from 0.35 · 1 to 1.29 · 1, differences which are so great that an independent Mendelian segregation cannot be

TABLE VIII The proportion of the number of plants.
A) with red flowers and red leaf margin.
B) with red flowers and green leaves
C) with yellow flowers and green leaves.

Sowing	Number of plants			Proportions	
	A	B	C	A · B : C	red : yellow
1	34	15	15	2,27 · 1 · 1	3,27 : 1
2	22	5	6	3,67 : 0,83 · 1	4,50 : 1
3	76	19	45	1,69 : 0,42 : 1	2,11 : 1
4	24	10	15	1,60 : 0,67 : 1	2,27 : 1
5	108	18	52	2,08 · 0,35 · 1	2,42 : 1
6	79	23	25	3,16 : 0,92 · 1	4,08 : 1
7	49	18	14	3,50 : 1,29 : 1	4,79 : 1
Total	392	108	172	2,28 : 0,63 : 1	2,79 : 1

recognized for the separate sowings, and at most only for the total and non-red (yellow) flowers.

If the fourth and fifth columns of table IV for the number of staminodes is split in the same way as in table VIII, according to the colour of leaves and flowers, it is found that the first four sowings produced twice as many plants with yellow flowers having 2 or 2—3 staminodes as plants with red flowers, although the latter are two and a half times as numerous (205 as against 81).

TABLE IX. The proportionally large number of plants with yellow flowers having 2 or 2—3 staminodes.

Sowing	Three to two staminodes			Two staminodes			Total number	
	A	B	C	A	B	C	A + B	C
1	1	—	—	—	—	1	49	15
2	2	—	4	—	—	—	95	45
3	1	—	1	—	—	—	27	6
4	1	—	3	—	—	1	34	15
(Sum)	5	0	8	0	0	2	205	81
5	5	1	3	2	—	2	126	52
6	6	2	2	1	—	—	102	25
7	3	—	3	1	—	1	67	14
(Sum)	14	3	8	4	0	3	295	91

Hence there is a tendency towards coupling between the factors for red flowers and those for 3 staminodes, especially clearly among the plants with red flowers and green leaves (B), which in table IX hardly occur among the last three sowings; the latter deviate considerably from the first four, in which such flowers are entirely wanting. It is among the non-red (yellow) individuals that most plants are found to be wholly or partially recessive for the characters of the staminode number.

Summarizing we may conclude for the F₂ offspring of the cross *Canna glauca* × *C. indica*, in which more hereditary factors were brought together than the number of chromosomes that 1) for the factors of the red leaf margin, for the layer of wax in the leaves,

and for the number, the length and the colour of the staminodes, the proportions of the phenotypes differ widely in the different sowings, in spite of the fact that the F1 consisted of a single individual; so that the segregation of the hybrids is variable;

2) that in none of the sowings the segregation ratios correspond to those which may be expected from an independent Mendelian segregation.

Chemistry. — “*In-, mono- and divariant equilibria*”. XII. By Prof. F. A. H. SCHREINEMAKERS.

(Communicated in the meeting of November 26, 1916).

19. *Ternary systems with two indifferent phases.*

In communication II we have seen that in ternary systems three types of P, T -diagram [fig. 2 (II), 4 (II) and 6 (II)] exist. When, however, two indifferent phases occur in the invariant point, then, as we shall see further, four types of P, T -diagram exist.

When in the invariant point two indifferent phases occur, then consequently there are three singular phases, they are represented by three points, situated on a straight line. In the types of concentration-diagram of figs. 1, 3, 5 and 7 the indifferent phases are represented by A and B , the singular phases by C , D and E .

In figs. 1 and 3 A and B are situated on the same side, in figs. 5 and 7 on different sides of the line CDE .

In fig. 1 the prolongation of the line AB intersects the prolongation of the line EDC , in fig. 3 the prolongation of AB intersects the line CDE in a point between C and D . [Of course the type of concentration-diagram of fig. 3 remains unchanged, when the point of intersection was situated between D and E].

In fig. 5 the point of intersection of AB and CDE is situated on the line CDE , in fig. 7, however, on the prolongation of the line CDE .

Of course a type of P, T -diagram belongs to each of the four types of concentration-diagram, they are represented in the figs. 2, 4, 6 and 8. We find in each of these diagrams:

the three singular curves:

$$(M) = C + D + E$$

$$(A) = B + C + D + E = B + (M)$$

$$(B) = A + C + D + E = A + (M)$$

and further the curves:

$$(C) = A + B + D + E$$

$$(D) = A + B + C + E$$

$$(E) = A + B + C + D$$

In the singular equilibrium (M) the reaction:

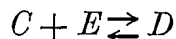

may occur. Hence it follows for the partition of the curves with respect to the (M)-curve:

$$(C)(E) | (M) | (D) \dots \dots \dots (1)$$

In each of the figs. 2, 4, 6, and 8 the curves (C) and (E) must be situated, therefore, at the one side and curve (D) at the other side of the (M)-curve.

In communication I we have deduced the rule for the partition of the curves for the general case, that each curve of a system of n components represents an equilibrium of $n + 1$ phases. As the (M)-curve represents, however, an equilibrium of only n phases, we have to deduce this rule also for this case.

As the (M)-curve coincides with the two other singular curves (A) and (B), we may consider instead of the (M)-curve also curve (A) or (B). In the equilibrium $(A) = B + C + D + E$, as B takes no part in the reaction as indifferent phase, the reaction:

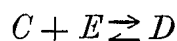

occurs. Hence follows for the partition of the regions with respect to curve (A):

$$B + C + E \left| \begin{array}{l} B + E + D \\ B + C + D \end{array} \right.$$

Each of those regions is limited, besides by curve (A), also by an other curve; the region $B + C + E$ by curve (D), the region $B + E + D$ by curve (C) and the region $B + C + D$ by curve (E). As each region-angle is smaller than 180° , it appears that curve (D) must be situated at the one side, and the curves (C) and (E) at the other side of (A). Consequently we find:

$$(C)(E) | (A) | (D)$$

or, as the curves (A) and (M) coincide:

$$(C)(E) | (M) | (D).$$

Now already we know, therefore, that in each P, T -diagram-type the curves (C) and (E) must be situated at the one, and curve (D) at the other side of the (M)-curve. It is apparent, however, that this is not sufficient to determine the P, T -diagram-type completely. Now we shall deduce this type for each of the four cases.

a) The five phases form a concentration-diagram-type as in fig. 1.

From the position of the phases with respect to one another follow the reactions:



and from this:

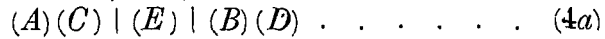
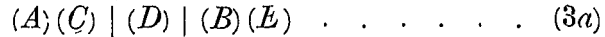
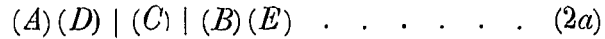

It appears from 2a, 3a and 4a that the curves (A) and (B) are situated at different sides of each of the three curves (C), (D) and (E). As (A) and (B) are singular curves and they coincide, therefore, with the (M)-curve, the (M)-curve is consequently bidirectional. We draw, therefore, in a P,T-diagram the curves (A), (B) and (M) as in fig. 2.

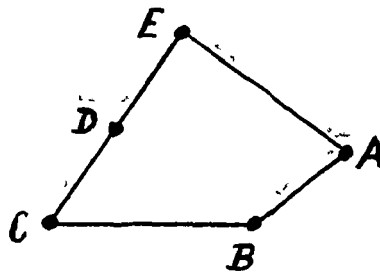

Fig. 1.

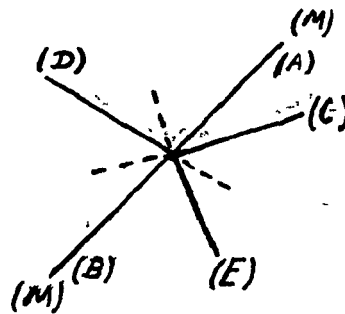

Fig. 2.

At the one side of the (M)-curve we draw curve (D) [fig. 2]; at the other side of the (M)-curve are situated then the curves (C) and (E), of which the position with respect to (A) and (B) has still to be defined. It appears from 3a that (A) and (C) are situated at the one and (B) and (E) at the other side of curve (D); the curves (C) and (E) are situated, therefore, as in fig. 2.

We see that this diagram is also in accordance with 2a and 4a.

b) The five phases form a type of concentration-diagram as in fig. 3.

From the position of the phases with respect to one another follows:

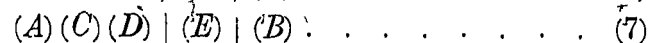
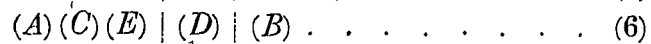
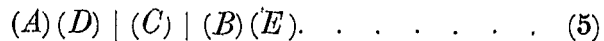

Because, as it appears from (5), (6), and (7), the singular curves

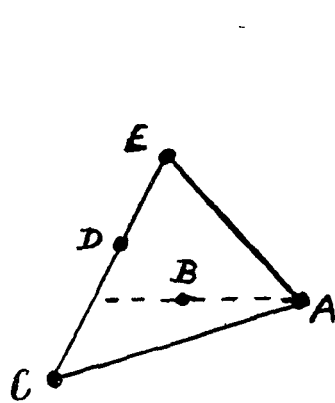

Fig. 3.

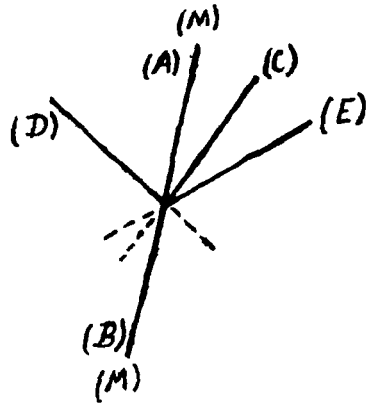

Fig 4

(A) and (B) are situated on different sides of each of the three curves (C), (D) and (E), it follows again that the (M)-curve is bidirectional. With the aid of (1) and (6) we find a type of *P, T*-diagram as in fig. 4. We see that this diagram is also in accordance with (5) and (7).

c) The five phases form a type of concentration diagram as in fig. 5.

From the position of the phases with respect to one another follows:

$$(A) (B) (E) | (C) | (D) \dots \dots \dots (8)$$

$$(A) (B) | (D) | (C) (E) \dots \dots \dots (9)$$

$$(A) (B) | (E) | (C) (D) \dots \dots \dots (10)$$

Hence it appears that the singular curves (A) and (B) are situated on the same side of the three curves (C), (D) and (E); the (M)-curve is, therefore, monodirectional and the three singular curves (M), (A) and (B) coincide, therefore, in the same direction. We draw, therefore, in a *P, T*-diagram those three curves as in fig. 6. When we draw

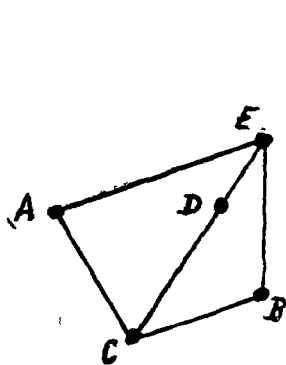

Fig. 5.

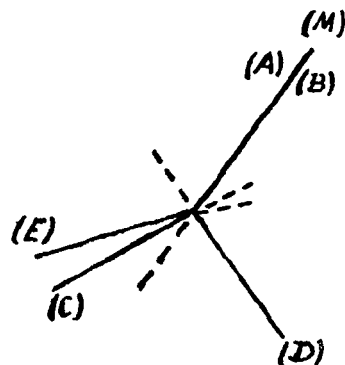

Fig. 6.

on the one side of the (M) -curve the curve (D) , then (C) and (E) must be situated on the other side. Now it follows further from (9) that (C) and (E) must be situated within the angle which is formed by the metastable parts of the curves (D) and (M) . Now it appears from (8) or (10) that those curves (C) and (E) must be situated, as is drawn in fig. 6.

d) The five phases form a type of concentration-diagram as in fig. 7. From the position of the phases with respect to one another follows:

$$(A) (B) (E) | (C) | (D) \dots \dots \dots (11)$$

$$(A) (B) (E) | (D) | (C) \dots \dots \dots (12)$$

$$(A) (B) (D) | (E) | (C) \dots \dots \dots (13)$$

Because, as it appears from (11), (12) and (13) the singular curves (A) and (B) are situated on the same side of each of the three curves (C) , (D) and (E) , the (M) -curve is, therefore, monodirectionable and the three singular curves (M) , (A) and (B) coincide, therefore, in the same direction. Now we draw those three curves in a P, T -diagram, as in fig. 8. When we draw curve (D) at the one side of

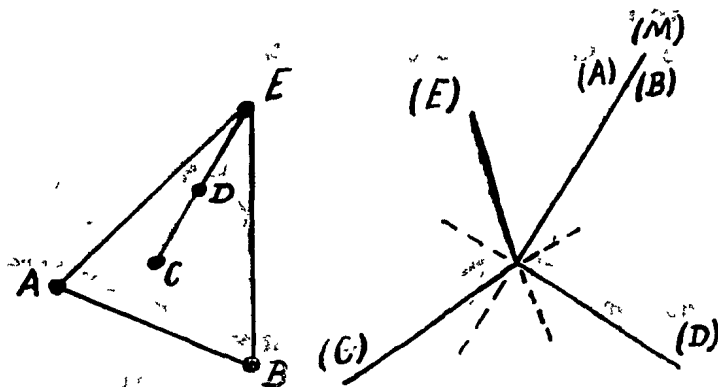

Fig. 7.

Fig. 8.

the (M) -curve, then (C) and (E) must be situated at the other side. It appears from (12) that (C) must be situated at the one side, and (A) , (B) and (E) at the other side of (D) ; we obtain, therefore a type of P, T -diagram as in fig. 8.

We are also able to find the different types of P, T -diagram by using the three main-types of P, T -diagrams [viz. I, IIA and IIB], which we have deduced in communication X.

In main-type I curve (M) , is monodirectionable, so that the three singular curves coincide in the same direction; the P, T -diagram of a system of n -components has then the same appearance as that of a system with $n-1$ components. The P, T -diagram of a ternary

system has, therefore, the same appearance as that of a binary system; consequently it exists, as 2 (I), of one two-curvical and two one-curvical bundles. One of the curves of this figure must represent now the three coinciding singular curves.

When the singular curves are represented by one of the curves of the two-curvical bundle, then fig. 8 arises; when they are represented by one of the two other curves, then fig. 6 arises.

In main-type II curve (M) is bidirectional; the two other singular curves coincide therefore in opposite direction [fig. 2 X, 3 X] and 4 (X)].

In main-type II A curve (M) is a middle-curve of the (M)-bundle [fig. 3 (X)]. The type of P, T -diagram consists of:

$$(M)\text{-bundle} + 2x \text{ other bundles}$$

viz. x bundles on each of the sides of the (M)-bundle. [In fig. 3 (X) is $x = 2$]. The (M)-bundle itself consists of one curve at the one side and three curves at least at the other side of the invariant point; it consists, therefore, of four curves at least. [In fig. 3 X of 5].

When we take an (M)-bundle of 4 curves, then, as 5 curves occur in the invariant point, $4 + 2x = 5$, consequently $x = \frac{1}{2}$. An (M)-bundle of four curves cannot exist, therefore. When we take an (M)-bundle of 5 curves, then $5 + 2x = 5$ or $x = 0$. Consequently the P, T -diagram consists only of an (M)-bundle of 5 curves; we obtain, therefore, a diagram as in fig. 4.

In main-type II B curve (M) is a side-curve of the (M)-bundle [fig. 4 X]. The type of P, T -diagram consists, therefore, of:

$$(M)\text{-bundle} + (2x + 1) \text{ other bundles}$$

viz. x bundles at the one side and $(x + 1)$ bundles at the other side of the M -bundle. [In fig. 4 (X) is $x = 1$]. The M -bundle consists of two curves at least at each side of the invariant point; consequently it consists of four curves at least. [In fig. 4 (X) of '6].

When we take an (M)-bundle of four curves, then $4 + 2x + 1 = 5$, consequently $x = 0$. At the one side of the (M)-bundle is situated, therefore, one curve [viz. $x + 1 = 1$] on the other side not a single curve is situated [viz. $x = 0$]. Now we obtain the type of P, T -diagram of fig. 2.

In communication (X) we have deduced the rules:

1. The two indifferent phases have the same sign or in other words: the singular equilibrium (M) is transformable into the invariant one and reversally. Curve (M) is monodirectional; the three singular curves coincide in the same direction [fig. 1 (X)].

2. The two indifferent phases have opposite sign or in other words: the singular equilibrium (M) is not transformable. Curve (M) is bidirectionable; both the other singular curves coincide in opposite direction [fig. 2 (X), 3 (X) and 4 (X)].

The four types of P, T -diagram [figs. 2, 4, 6 and 8] are in accordance with those rules. In figs. 5 and 7 the singular equilibrium (M) = $C + D + E$ is viz. transformable; in accordance with rule 1 in figs. 6 and 8 the (M)-curve is monodirectionable. In figs. 1 and 3 the singular equilibrium (M) is not transformable; in accordance with rule 2 the (M)-curve is bidirectionable in figs. 2 and 4.

We may also deduce the types of P, T -diagram from the types, which are valid for ternary systems without indifferent phases; we find them in the figs. 2 (II), 4 (II) and 6 (II). [We have to bear in mind that the figs. 4 (II) and 6 (II) must be changed mutually.]

We may consider viz. fig. 1 as a particular case of fig. 1 (II) or 3 (II). When viz. in fig. 1 (II) we let point 5 coincide with a point of the line 23, then this concentration-diagram passes into the type of fig. 1; this is also the case when point 4 coincides with a point of the line 12, or point 3 with a point of the line 15 etc. When point 5 coincides with a point of the line 23, then 1 and 4 are the indifferent phases and (1) and (4) the singular equilibria. In the P, T -diagram of fig. 2 (II) the singular curves (1) and (4) must then coincide; it is apparent from the figure that this coincidence must take place in opposite direction. The P, T -diagram of fig. 2 (II) passes then into the type of fig. 2.

When in fig. 3 (II) point 4 coincides with a point of the line 12, then this concentration-diagram passes also into that of fig. 1. The indifferent phases are then represented by 3 and 5, the singular equilibria by (3) and (5). In the P, T -diagram of fig. 4 (II) the curves (3) and (5) coincide then in opposite direction; then the P, T -diagram becomes the same as that of fig. 1.

In the same way we are also able to deduce the other types of the P, T -diagram. We may viz. consider fig. 3 as a particular case of fig. 3 (II) or 5 (II). Fig. 5 is to be considered as a special case of fig. 3; fig. 7 as a particular case of fig. 5.

When in a ternary system no indifferent phases occur, then, as we have seen in communication II, the curves succeed one another in "diagonal succession". With the aid of this rule we are also able to find the succession of the curves, when two indifferent phases occur.

In order to apply this rule to fig. 1 we imagine the point D a little left from the line CE ; then we obtain a concentration-diagram of the type of fig. 1 (II), viz. a convex quintangle. The diagonal succession of the phases is then: $A-C-E-B-D-A$; the succession of the curves in the P, T -diagram must be, therefore, $(A)-(C)-(E)-(B)-(D)-(A)$ or reversally, we see that this is in accordance with fig. 2.

When we imagine the point D a little right from the line CE , then the concentration-diagram forms a monoconcave quintangle, as in fig. 3 (II). The diagonal succession of the phases is then also: $A-C-E-B-D$, so that the curves have to succeed one another as in fig. 2.

In order to apply the rule to fig. 3 we imagine in this figure the point D a little at the right or at the left of the line CE . In the first case a biconcave quintangle arises [fig. 5 (II)], in the second case a monoconcave quintangle [fig. 3 (II)]. In both cases the diagonal succession of the phases is: $A-C-E-B-D-A$; the succession of the curves in the P, T -diagram must be, therefore: $(A)-(C)-(E)-(B)-(D)$; this is in accordance with fig. 4.

In order to apply the rule to fig. 5, we imagine also the point D in this figure a little at the right or at the left of CE . In both cases a monoconcave quintangle arises [fig. 3 (II)]. The diagonal succession of the phases is then: $A-B-D-C-E$ or $A-B-E-C-D$. When we bear in mind that in the P, T -diagram the curves (A) and (B) coincide, then we get a succession of the curves as in fig. 6.

In order to find the succession of the curves in the P, T -diagram which belongs to fig. 7, we imagine in fig. 7 the point D to be situated again a little at the right or at the left of the line CE ; then in both cases a biconcave quintangle arises [fig. 5 (II)]. The diagonal succession of the phases is then $A-B-D-C-E$ or $A-B-E-C-D$. As the curves (A) and (B) coincide, a P, T -diagram as in fig. 8 arises.

In our previous considerations we have shifted a little the point D in each of the figures 1, 3, 5, and 7; it is evident that we might have shifted also the point C or E a little.

20. *Quaternary systems with two indifferent phases.*

We have seen in communication III that four types of P, T -diagram exist in quaternary systems. When however, 2 indifferent phases occur in the invariant point, then, as we shall see further, 12 types occur. In order to find those types, we might, just as in

the case of the ternary systems, construct the different concentration-diagrams and the type of P, T -diagram belonging to each of those diagrams. Now we shall deduce them, however, without using the concentration-diagrams, with the aid of the three main-types I, IIA and IIB, which we have deduced in communication X.

In main-type I curve (M) is monodirectionable and the 3 singular curves coincide in the same direction. Consequently the P, T -diagram has the same appearance as that of a ternary system. In the types of P, T -diagram of the ternary systems [fig. 2 (II), 4 (II) and 6 (II)] we let one of the curves represent the (M)-curve. Then we find the following diagrams:

$$B(M) + B_1 + B_1 + B_1 + B_1 \dots \dots \dots (1)$$

$$B(M) + B_2 + B_2 \dots \dots \dots (2)$$

$$B_1 + B(M+1) + B_2 \dots \dots \dots (3)$$

$$B_1 + B(1+M) + B_2 \dots \dots \dots (4)$$

$$B(M) + B_1 + B_2 \dots \dots \dots (5)$$

$$B_1 + B_1 + B(M+2) \dots \dots \dots (6)$$

$$B_1 + B_1 + B(1+M+1) \dots \dots \dots (7)$$

Herein B_1 means an onecurvical bundle, B_2 a twocurvical bundle etc., $B(M)$ indicates a bundle which consists of the (M)-curve only, $B(M+1)$ a bundle, which consists of the (M)-curve and still another curve, etc.

With the aid of main-type II A we find the diagrams

$$B(M) + B_1 + B(1+M+1) + B_1 \dots \dots (8)$$

$$B(M) + B(1+M+3) \dots \dots \dots (9)$$

$$B(M) + B(2+M+2) \dots \dots \dots (10)$$

With the aid of main-type II B we find yet the diagrams:

$$B(M+1) + B(1+M) + B_2 \dots \dots (11)$$

$$B(M+1) + B(2+M) + B_1 \dots \dots (12)$$

The reader himself may easily draw the 12 P, T -diagrams of which the diagrams (1)—(12) are the symbolical representations.

(To be continued).

Leiden, Inorg. Chem. Lab.

