



FÉDÉRATION INTERNATIONALE  
DE MOTOCYCLISME

**TECHNICAL RULES  
TRACK RACING**  
(INCLUDING RULES FOR MOTOBALL)

**2014**

*REGLEMENTS TECHNIQUES  
COURSES SUR PISTES*  
(RÈGLEMENTS POUR MOTOBALL INCLUS)

**Technical Rules for Track Racing  
(Including Rules for Motoball)**

**2014**

***Règlements Techniques pour  
Courses sur Pistes  
(Règlements pour Motoball inclus)***

# TECHNICAL RULES FOR TRACK RACING (CCP)

## Table of Contents

01.01	INTRODUCTION .....
01.03	FREEDOM OF CONSTRUCTION .....
01.05	CATEGORY AND GROUPS .....
01.07	CLASSES .....
01.11	MEASUREMENT OF CAPACITY .....
01.17	SUPERCHARGING .....
01.19	MOTORCYCLE WEIGHTS .....
01.21	DESIGNATION OF MAKE .....
01.23	DEFINITION OF A PROTOTYPE .....
01.25	GENERAL SPECIFICATIONS .....
01.26	DEFINITION OF A FRAME OF A SOLO MOTORCYCLE .....
01.27	STARTING DEVICES .....
01.29	OPEN TRANSMISSION GUARDS .....
<b>01.31</b>	<b>EXHAUST PIPES AND SILENCERS .....</b>
01.33	HANDLEBARS .....
01.35	CONTROL LEVERS .....
01.37	THROTTLE CONTROLS .....
01.39	FOOTRESTS .....
01.41	BRAKES .....
01.43	MUDGUARDS AND WHEEL PROTECTION .....
01.45	STREAMLINING .....
01.46	INCLINATION AND SUSPENSION OF MOTORCYCLES .....
01.47	WHEELS, RIMS, TYRES .....
01.49	TYRES FOR SPEEDWAY MOTORCYCLES AND TRACK RACING SIDECARS .....
01.50	TYRES FOR LONG TRACK MOTORCYCLES .....
01.51	TYRES FOR ICE RACING MOTORCYCLES .....
01.52	WHEELS, RIMS AND TYRES FOR TRACK RACING SIDECARS ..
<b>01.53</b>	<b>ADDITIONAL SPECIFICATIONS FOR SIDECARS .....</b>
<b>01.54</b>	<b>ADDITIONAL RULES FOR 1000 CC TRACK RACING SIDECARS .....</b>
01.55	NUMBER PLATES .....
01.56	OIL CATCH TANKS .....
<b>01.58</b>	<b>SPECIFICATION OF TRACK RACING MOTORCYCLES .....</b>
<b>01.59</b>	<b>SPECIFICATION OF ICE RACING MOTORCYCLES .....</b>
01.60	CARBURETTORS FOR GRASS TRACK MOTORCYCLES .....
01.63	FUEL, FUEL/OIL MIXTURES .....
01.65	EQUIPMENT AND PROTECTIVE CLOTHING .....
01.67	WEARING OF HELMETS .....
01.69	HELMET OPERATIVE INSTRUCTIONS .....
01.70	RECOGNISED INTERNATIONAL HELMET APPROVAL MARKS ..

01.71	EYE PROTECTION.....
01.75	BADGE OF THE FIM .....
01.77	CONTROL.....
01.78	SCRUTINEERING GUIDELINES FOR TECHNICAL STEWARDS AND DECLARATION .....
01.79	SOUND LEVEL CONTROL .....
01.80	GUIDELINES FOR USE OF SOUND LEVEL METERS .....
01.81	TIME KEEPING .....
<b>01.82</b>	<b>TECHNICAL SPECIFICATIONS FOR MOTOBALL .....</b>
<b>01.83</b>	<b>ADDITIONAL RULES FOR 80cc SPEEDWAY MOTORCYCLES ...</b>
<b>01.84</b>	<b>TECHNICAL SPECIFICATIONS FOR 125cc GRASS TRACK MOTORCYCLES .....</b>
<b>01.85</b>	<b>TECHNICAL SPECIFICATIONS FOR FLAT TRACK MOTORCYCLES</b>

**DIAGRAMS AND TABLE**

## **01.01 INTRODUCTION**

The term motorcycle covers all vehicles having, in principle, less than four wheels, propelled by an engine and designed essentially for the carriage of one or more persons of which one is the rider of the vehicle. The wheels must normally be in contact with the ground except momentarily or in certain exceptional circumstances. Furthermore, in order to traverse certain surfaces one or all of the wheels can be replaced with skis, rollers or chains.

## **01.03 FREEDOM OF CONSTRUCTION**

A motorcycle must conform to the requirements of the FIM regulations, to the Supplementary Regulations, as well as to a number of specific conditions that the FIM may require for certain competitions. No restriction is placed on the make, construction or type of motorcycle used.

All solo motorcycles (Group A) must be constructed in such a way that they are entirely controlled by a rider. Motorcycles with Sidecars (Group B) must be constructed to carry a passenger.

## **01.05 CATEGORY AND GROUPS**

Motorcycles are divided into categories which must be observed for all meetings and world record attempts.

In principle, it is forbidden for different categories, groups and classes to compete in the same race, unless the Supplementary Regulations state otherwise.

### **Category I**

Motorcycles propelled by the action of one wheel in contact with the ground.

The other categories are not applicable to Track Racing.

### **Group A1 - Solo Motorcycles**

2-wheel vehicles making only one track on the ground.

### **Group B1**

Vehicles with three wheels, making two tracks on the ground, consisting of a motorcycle making one track and a Sidecar for a passenger making the other.

### **Group B2**

Vehicles with three wheels, making two or three tracks on the ground in the direction of forward travel, with a permanently attached Sidecar forming a complete integral unit.

If three tracks are made, the **centre-lines** of the two tracks made by the motorcycle wheels must not be more than 75 mm apart. A track is determined by the longitudinal centre-line of each of the vehicle's wheels in the direction of forward travel.

**01.07 CLASSES**

Groups are again separated into classes according to cylinder capacities as detailed below. These classes must be observed for all meetings.

**Category I**

**Group A1 Motorcycles**

Class	Over (cc)	Up to (cc)
50	-	50
80	50	85
100	85	100
125	100	125
175	125	175
250	175	250
350	250	350
500	350	500
750	500	750
1000	750	1000
1300	1000	1300

For Classic Speedway, Long Track and Ice Racing:

- 250cc Class: Up to 250cc 4 stroke single cylinder engines
- 500cc Class: Up to 500cc 4 stroke single cylinder engines

**Groups B1, B2 Sidecars**

Same as groups A1 and A2 over 175 cc.

**01.11 MEASUREMENT OF CAPACITY**

**11.11 Reciprocating movement engine, "Otto" Cycle**

The capacity of each engine cylinder is calculated by the geometric formula which gives the volume of a cylinder; the diameter is represented by the bore, and the height by the space swept by the piston from its highest to lowest point:

$$\text{Capacity} = \frac{D^2 \times 3.1416 \times C}{4}$$

where D = bore

and  $C = \text{stroke}$

When a cylinder bore is not circular the cross sectional area must be determined by a suitable geometrical method or calculation, then multiplied by the stroke to determine capacity.

When measuring, a tolerance of 1/10 mm is permitted in the bore. If with this tolerance the capacity limit is exceeded for the class in question, a further measurement should be taken with the engine cold, to 1/100 mm limits.

### **01.17 SUPERCHARGING**

Supercharging by means of a device of any kind is forbidden in all meetings.

An engine whether 2-stroke or 4-stroke coming within any one of the recognised classes (determined by the capacity of the working cylinder) shall not be considered as supercharged when in respect of one engine cycle, the total capacity measured geometrically, of the fuel charging device or devices, including the capacity of the working cylinder (if used for injecting the fuel), does not exceed the maximum capacity of the class in question.

### **01.19 MOTORCYCLE WEIGHTS** **Weights of motorcycles without fuel**

- The minimum weights for motorcycles are:

For 80cc Speedway	55 kg
For 250cc Speedway	75 kg
For 500cc Speedway	77 kg
For 125cc Grass Track	60 kg
For 250cc Long Track	80 kg
For Long Track	82 kg
For Ice Racing	110 kg
For Grass Track Sidecars	120 kg
For 1000cc Track Racing Sidecars	180 kg

During the competition, motorcycles are weighed in the condition they leave the track after every heat (including the fuel).

### **19.01**

A 1 % tolerance in the weight of the machine after the race is accepted.

### **19.04**

Weighing scales must be certified annually by a National Institute.

### **19.05**

For Groups B1 and B2: a passenger must be carried at all competitions.

#### **01.21 DESIGNATION OF MAKE**

When two manufacturers are involved in the construction of a motorcycle the name of both must appear on the machine as follows:

- The name of the chassis manufacturer
- The name of the engine manufacturer

#### **01.23 DEFINITION OF A PROTOTYPE**

A prototype motorcycle is a vehicle which must conform to the safety requirements as required by the FIM Sporting Code and Appendices applicable to the type of competition for which it is to be used.

#### **01.25 GENERAL SPECIFICATIONS**

The following specifications apply to all vehicles of the groups indicated and to all types of competitions except where otherwise stated in the corresponding section of the FIM Sporting Code.

They should also be applied to all national competitions unless the FMNR (National Motorcycling Federation) has otherwise directed.

Further specifications for some competitions may also be required and these will be detailed in either the appropriate FIM Appendix or in the Supplementary Regulations for the competition in question.

#### **25.01 Titanium**

As from 01.01.2013, the use of titanium is permitted, with the exception of the front fork, the frame, handlebars, swing-arm and swing-arm spindle, and front and rear wheel spindles.

See also Art. 54.07.5, 54.10 and 83.04.1.

#### **25.03 Carbon fiber**

The use of carbon fiber in Track Racing machines is authorised (with the exception of handlebars made from carbon-carbon, carbon-kevlar and or other composite materials).

#### **25.04 Ceramic materials**

The use of ceramic parts is forbidden. The use of ceramic coated parts is authorised.



## **25.05**

The use of data recording devices and automatic electronic ignition is authorised. **The use of a device or switch to alter the ignition physically or manually by the rider during a race is not permitted.**

No signal of any kind may pass between a moving motorcycle and anyone connected with the motorcycle's entrant or rider, except for the signal from the time keeping transponder or from the on-board cameras.

## **25.06**

For all races (with the exception of 1000cc Track Racing Sidecars), only single cylinder engines are allowed.

## **25.08**

Carburettors only can be used. Any electronic tuning devices are forbidden.

## **01.26 DEFINITION OF A FRAME OF A SOLO MOTORCYCLE**

The structure or structures used to join any steering mechanism at the front of the machine to the engine/gear box unit and to all components of the rear suspension.

## **01.27 STARTING DEVICES**

Starting devices are not compulsory.

## **01.29 OPEN TRANSMISSION GUARDS**

### **29.01**

The primary transmission must have a guard as a safety measure, small holes (max 10mm) in the transmission/clutch guards are allowed for extra cooling.

Excessive cutting of the guard is not allowed. Cutting of the guard is only permitted to expose the clutch pressure plate and to allow adjustments to the clutch springs.

The guard must be conceived in such a way that under no circumstances the rider or the passenger can come accidentally in contact with the transmission/clutch parts. It must be designed to protect the rider from injuring his fingers.

An additional protective device must be provided to prevent a broken primary chain from flying upwards.

This can be provided by either a fully enclosed steel chain guard, or, if a chain guard is made from plastic or from other material, then a steel bolt of 10 mm minimum diameter

must be placed outside the bottom rear quadrant of the clutch sprocket (see diagrams G/H/K). This bolt, if damaged, must always be completely replaced.

A guard/cover must be fitted to the countershaft sprocket (if it is exposed).

### **29.03**

A guard must be fitted to provide protection also where the rear chain enters onto the rear wheel sprocket.

## **01.31 EXHAUST PIPES AND SILENCERS**

Exhaust pipes and silencers must fulfil all the requirements concerning sound-level control. Exhaust fumes must be discharged towards the rear but not in a manner as to raise dust, foul the tyres or brakes, or inconvenience a passenger, if there is one, or any other riders.

### **FROM 01.01.2015, NEW CONSTRUCTION REQUIREMENTS FOR SILENCERS**

FIM announced in April 2013 the following new construction requirements for silencers in Track Racing (for all 500cc and 250cc single cylinder engines running on methanol).

- All silencers used must be homologated by the FIM.
- The FIM silencer homologation consists of several sound tests. Every sound test will be made by using a conventional exhaust pipe and a modified exhaust pipe (see description in Nr 1). Sound tests will be made with the FIM nominated official.

#### **1. Exhaust pipe**

A single main exhaust pipe, maximum 50 mm external diameter is prescribed. An exhaust pipe may include external or internal sound suppression systems to reduce the sound level. Material is free. (Requirements to fix the exhaust pipe remain the unchanged).

#### **2. Silencer construction**

The silencer must be made as one complete, sealed unit without any removable parts.

The silencer must be a mechanical type, using the position of permanently fixed pipes, baffles or plates to reduce the sound to the maximum permitted sound level.

Insulating material, for the sole purpose of reducing the external temperature of the silencer body, is permitted provided it is contained within a sealed chamber that has no contact with exhaust gas or the outside atmosphere.

The end of the silencer exhaust pipe, when fitted on the motorcycle, must remain horizontal and parallel to the central axis of the machine (max.

tolerance: +/- 10°). The maximum length is 20 mm (including a rounded collar); the maximum internal diameter of the pipe exit is 45 mm (+ 2.0 mm tolerance). The end of the silencer must finish at a right angle and contain a rounded collar (min. 5mm/max. 10 mm).

Fixing points to attach a heat shield must be included.

### 3. Silencer length and location

The position of the silencer is provided by the following limitations: the silencer/exhaust system shall not exceed the leading edge of the rear wheel when viewed from the side and leave space for the riders' foot. The silencer exit is behind the rider and within the rear tyre silhouette of the motorcycle when viewed from the side.

### 4. Maximum permitted sound level: 112 dB/A (from 01.01.2015)

All new silencer presented for approval shall not exceed the maximum permitted sound level of 112 dB/A + 3 dB/A (within the values for the precision of the method, i.e. all tolerance values included). A Class 1/Type 1 sound meter is prescribed to make the sound tests.

Sound tests will be performed using the '2 meter max' method (see Art.01.79).

### 5. Engine RPM

All silencers presented for homologation will be tested with an engine RPM level of 11.000 rpm to test the sound limit produced by the combination of the exhaust and silencer.

### 6. Period of validity

The new FIM homologated silencer will be required as from 01/01/2015. The period of homologation is 5 years (as long as the silencer remains original).

Any new FIM homologated silencer shall be constructed according to these requirements and be within the maximum permitted sound level. A homologation fee will be applied.

## **31.01 FIM homologated silencers**

Only homologated silencers (see listing after the Diagrams) with their year of production stamped will be accepted for Speedway 500cc and 250cc, Ice Racing and Long Track 500cc and 250cc in FIM meetings.

Silencers for 500cc and 250cc Track Racing motorcycles must be homologated by the FIM. Any homologation will be valid for five years from the year of homologation.

Modifying the homologated silencer is not permitted on 250cc & 500cc Track Racing motorcycles. The only modification allowed to fit silencers for use on 250cc Track Racing motorcycles, is the reduction of the inlet diameter of the silencer down to 40mm.

## **31.03 Construction requirements (until 31.12.2014) (From 01.01.2013, see below NEW construction requirements)**

The silencer must be of a mechanical or "baffle" type, depending only on the position of permanently fixed internal pipes and plates to achieve the required maximum sound level.

A straight tube, directly connecting inlet and outlet of the silencer, without deflection of exhaust gas, is not permitted.

An exhaust extraction (megaphone) effect must not be caused by the positioning of any tapered, conical or other shaped parts.

The silencer must be made as one complete, sealed unit, without any removable parts.

**31.03.1** The exhaust pipe must be fixed to the cylinder head and frame with a minimum of 3 clips (the point of fixture at the cylinder head is considered as one clip). The silencer must be fixed to the frame with at least one clip.

Additionally, a second flexible coupling must be fitted from the first third of the silencer to the frame. This second coupling should be a steel cable of at least 3 mm Ø or strong steel spring.

**31.03.2** The outside diameter of the single exhaust pipe must not exceed 50mm and must be constant, in principle, over its entire length. **An extra volume, a sound suppression system (max diameter 50 mm/ max length 250 mm), may be added, welded securely on top and parallel to the exhaust pipe.**

**31.03.3** The outlet area of the silencer must remain constant over a length of 50mm and must not exceed 45mm internal diameter or an equivalent area and must not be perforated (no slots, holes, etc.).

**31.03.4** The end of the exhaust pipe, over a minimum distance of 30mm, must be horizontal and parallel to the central axis of the solo machine (with a tolerance of  $\pm 10^\circ$ ).

**31.03.5** The end of the pipe must be cut at a right angle. The end of the silencer must be cut at a right angle. The silencer end must be a rounded edge with a diameter of 5mm minimum. See diagrams G, H, K and P.

**31.03.6** Between the silencer and the tyre a maximum gap of 60mm (90mm for Ice Racing), with a tolerance of +/- 10mm), must not exceed (see diagram P).

**31.03.7** From 2013, it is compulsory that all homologated silencers be fitted with a heat shield (guard), securely mounted on the exterior of the silencer, to give extra protection to riders in the event of close contact (**recommended for Ice racing**).

All newly FIM homologated silencers (2012 models and later) shall be equipped with a heat shield (guard), provided by the manufacturer of the silencer or their supplier.

## **31.04**

The exhaust system must not extend beyond the outer circumference of the rear tyre, and must not end further forward than the centre of the rear wheel.

### **31.05**

On a Sidecar motorcycle, the exhaust must discharge horizontally and towards the rear, at a maximum angle of 30° to the axis of the machine, and at the end must be of constant diameter over a distance of 30mm.

## **01.33 HANDLEBARS**

### **33.01**

The width of handlebars is:

85/125 cc:	Not less than 650 mm and not more than 850 mm.
250cc/500 cc Track Racing:	Not less than 700 mm and not more than 900 mm.
Ice Racing:	Minimum: 700 mm, maximum width: 800 mm.
All other:	Not less than 700 mm and not more than 900 mm.

### **33.03**

Exposed handlebar ends must be plugged with a solid material or rubber covered.

### **33.04**

Handlebar clamps must be very carefully radiuses and engineered so as to avoid any cracks in the handlebar.

### **33.05**

When light alloy handlebars are used, the distance between the two extremities of the clamping area (or of the 2 clamps) must not be less than 120 mm.

### **33.06**

If hand protectors are used they must be of a shatter-resistant material and have a permanent opening for the hand.

### **33.07**

For Ice racing, the extremity of the left handlebar must be fitted with an integral steel ball of at least 28 mm in diameter. Clip-on handlebars consisting of two separate parts are forbidden.

### **33.08**

For Grass Track racing Sidecars, the minimum angle of rotation of the handlebar on each side of the centre line or mid position must be at least 40°. The steering must be

effected only through the motorcycle front wheel and its steering fork. A steerable sidecar wheel is forbidden.

### **33.09**

Handlebar clamps must be very carefully radiused and engineered so as to avoid fracture points in the bar.

### **33.10**

If hand protectors are used they must be of a shatter-resistant material.

### **33.11**

The repair by welding of light alloy handlebars is prohibited.

### **33.12**

Handlebars made from carbon-carbon, carbon-kevlar and/or other composite materials are not authorised.

## **01.35 CONTROL LEVERS**

### **35.01**

All handlebar levers (clutch, brake, etc.) must be in principle ball ended (diameter of this ball to be at least 16 mm). This ball can also be flattened, but in any case the edges must be rounded (minimum thickness of this flattened part 14 mm). These ends must be permanently fixed and form an integral part of the lever.

### **35.03**

Each control lever (hand and foot levers) must be mounted on an independent pivot.

**35.03.1** For Ice racing, a stop must provide a minimum clearance of 15 mm between the left hand control lever and the handlebar grip.

**35.03.2** Gear and clutch levers must be positioned in such a manner that the rider does not need to change his position to operate them.

**35.03.3** The lever must be mounted to swivel, so that at no time can the rider's fingers be trapped between the lever and the handlebars.

**35.03.4** The end of levers when closed must not be situated wider than the furthest extremity of the handlebar. For Ice Racing, the end of the levers shall not exceed the end of the handlebars.

### **35.04**

The brake lever if pivoted on the footrest axis must work under all circumstances, such as the footrest being bent or deformed.

## **01.37            THROTTLE CONTROLS**

### **37.01**

Throttle controls must be self closing when not held by the hand.

### **37.02            Ignition cut-out switches**

Solo motorcycles must be equipped with a functional ignition kill switch or button mounted on either right or left side of handlebar (within reach of the hand while on the hand grips) that is capable of stopping a running engine.

The ignition cut-out must be fitted on the handlebar, as close as is practicable to the throttle.

The ignition cut-out must stop the engine immediately, by the simple action of pulling a lanyard or a non-elastic string (which must be as short as possible) attached to the rider's right wrist.

## **01.39            FOOTRESTS**

### **39.02**

Footrests of motorcycles for Ice racing and all types of Solo Track racing shall be on the right hand side of the machine and must not exceed 320 mm in length measured from the centre line of the motorcycle (see diagrams G, H and K).

### **39.03**

For Track racing Sidecars, the footrest on the opposite side to the Sidecar must be protected at the front by a crash bar connected to the frame, so that injury or damage to other participants is prevented. The footrest must be fitted at a height of at least 150 mm from the ground.

## **01.41            BRAKES**

### **41.01**

Brakes are not permitted on Track Racing motorcycles.

## **01.43            MUDGUARDS AND WHEEL PROTECTION**

Motorcycles must be fitted with mudguards.

### **43.01**

Mudguards must project laterally beyond the tyre on each side. Both front and rear mudguards must be made of flexible materials (e.g. solid and rigid plastics, composite materials, rounded edges).

### **43.03**

For Speedway and Long Track, a front mudguard must extend at least 5° ahead of a vertical line running through the centre of the front wheel axle and at least 5° under the bottom edge of the mud shield fixed on the down tube of the frame). A rear mudguard must extend at least 5° behind a vertical line running through the centre of the rear wheel axle.

If the distance from the rear wheel tyre surface and the rear end of the rear mudguard is greater than 35mm, an additional wheel protection must be fitted. The gap between the wheel and the wheel protection must not be larger than 35mm (30 mm + 5 mm tolerance).

If a push bar is used, it should be made in one piece, of strong material which should not break under impact and must not protrude any higher than 35mm above the rear mudguard.

### **43.04**

A protection must be provided by enclosing the spokes with solid discs if cast or welded wheels are used in all types of racing.

### **43.05**

Both front and rear mudguards must be made of flexible materials and the mudguards shall not cause any injuries when damaged.

### **43.06**

For Track racing Sidecars, the mudguard of the rear wheel and the mudguard of the Sidecar must extend down at the rear to a maximum of 200 mm from the ground (see diagram L).

### **43.07      Mudguards for Ice Racing**

Mudguards must project laterally beyond the tyre on each side and the top half of the wheel (in circumference) must be completely covered (see Diagram H for dimensions).

The front mudguard should be made from composite materials (i.e. carbon/Kevlar® composites, fibreglass). The material shall be of appropriate strength and design and not to break or collapse under impact. Where necessary this may be achieved by the incorporation of reinforcement (for example a tubular protection of continuous construction) fixed to the front suspension.



The guard must be properly fixed to the front suspension.

The mudguard and/or the associated protection required must be designed to extend down at the rear of the wheel to a maximum of 250 mm from the surface of the ice and at the front must extend down to a maximum of 200 mm from the ice surface. (see diagram H).

On both sides of the front wheel the front mudguard must also extend down to the wheel spindle so that the top half of the wheel and the tyre are completely covered.

The rear mudguard should be made of composite materials (i.e. carbon/Kevlar® composites, fibreglass) and extend down at the rear of the wheel to a maximum of 250 mm from the ice surface.

On both sides of the rear wheel the rear mudguard must extend down to a maximum of 100 mm from the wheel spindle so that the top half of the wheel and the tyre are completely covered.

Additionally, a guard must be fitted to provide protection in front of the rear wheel in order to avoid the left leg getting injured by spikes.

#### **43.10**

Protection from the Sidecar wheel and the rear wheel for the passenger must be provided down to the level of the Sidecar platform.

#### **43.11**

The outside of the Sidecar wheel must either be completely covered by a disc extending to the wheel rim, or, the Sidecar mudguard must extend downwards on the outside to the centre of the wheel spindle.

### **01.45        STREAMLINING**

Streamlining is permitted.

Definition of streamlining: any addition to the handlebars or to the frame of the machine, the effect of which is to shield the rider's arms, legs or body from the air stream (with the exception of the normal front number plate).

### **01.46        INCLINATION AND SUSPENSION OF MOTORCYCLES**

The minimum angle of inclination for Ice racing machines is 68°.

### **01.47        WHEELS, RIMS AND TYRES (See Table 1)**

All tyres will be measured mounted on the rim at a pressure of 1 kg/cm (14 lb./sq.in.); measurements taken at a tyre section located 90° from the ground.

#### **47.02**

Any modification to the rim or spokes of an integral wheel (cast, moulded, riveted) as supplied by the manufacturer or of a traditional detachable rim (other than for spokes, valve or security bolts) is prohibited, except for tyre retention screws sometimes used to prevent tyre movement relative to the rim. If the rim is modified for these purposes, bolts, screws, etc., must be fitted.

#### **47.03**

Tyres may be inflated / filled with air and cannot be filled with any other substance to increase overall weight. Balancing weights only may be added and attached only to the rim or spokes.

### **01.49 TYRES FOR 250cc/500cc SPEEDWAY AND TRACK RACING SIDECARS (See also diagrams G and G bis)**

#### **49.01**

The overall width of the rear tyre must not exceed 100 mm (O).

#### **49.02**

The tread depth (A) must not exceed 8 mm measured at right angles to the face of the tread. All blocks in the same circumference must be of the same depth.

#### **49.03**

The space between the blocks must not exceed 9.5 mm across the tyre (B) or 13 mm in a circumferential direction (C).

#### **49.04**

The space between shoulder blocks (D) must not exceed 22 mm.

#### **49.05**

The space across the tread (E) must not extend completely across the tyre measured at right angles to the wall of the tyre, unless broken by a block.

#### **49.06**

All tread block (shoulder blocks excepted) must be nominally rectangular with sides parallel with or at right angles to the tyre axis (tyre must have same appearance when reversed and conform in principle with Diagram G bis).

#### **49.07**

The tyre surface must not be fitted with any subsequently mounted elements such as anti-skid spikes, special chains, etc.

#### **49.08**

All tread blocks (shoulder and main) may be laminated by the manufacturer with a maximum of 3 X 0.5 mm wide slots (sipes) per block, in the original mould.

Subsequent tyre modification(s) of any type **are** not permitted under any circumstances. (Tyres may not be treated by chemicals, tyre warmers or any other means, which may alter the shape, minimum shore hardness, construction or other characteristics).

#### **49.09**

For the front tyre, the only restriction is the overall width which is limited to 80 mm maximum.

#### **49.10**

Rear tyres mentioned in this article must be homologated by the manufacturers through the TUV or a similar National Institute of Standardisation in order to confirm the measurements and to approve the drawing. The results shall be sent to the FIM with a section of the tyre.

After receiving these results, the FIM shall issue a homologation number and this number must be engraved in the tyre mould. The homologation forms shall include the references to the minimum shore hardness figure at 20° and 100°C, as well as the construction and compound identification marks. A copy of the homologation forms must be sent to all FMNs (National Motorcycling Federations). Value for minimum 'shore' hardness: 70 ( $\pm 2$ ) at 20°C (reference).

The manufacturer has to engrave in the tyre mould: FIM/XX + Year of homologation (followed by the FIM Homologation number). Each tyre must clearly show the construction and compound identification marks.

The FIM reserves the right to sample tyres and test the tyres in a laboratory, comparing the test results with the example of the homologated tyre supplied at the time of homologation.

#### **49.11**

The rear tyre must be measured mounted on a rim, type WM 3 - 2.15 x 19" rim.

### **01.50 TYRES FOR 250cc/500cc LONG TRACK**

#### **50.01**

The dimension of the rear tyre for long track must have a rim diameter of 22" and a maximum width of 100 mm.

The tread depth (A) must not exceed 11 mm measured at right angles to the face of the tread. All blocks in the same circumference must be of the same depth (see Diagram G bis).

#### **50.02**

There is no restriction on the size or type of the front tyre.

#### **50.03**

The tyre delivered by the manufacturer must not be subsequently altered or cut.

### **01.51 TYRES FOR ICE RACING**

#### **51.01**

The tyre must be of special design.

#### **51.02**

The tyre's surface must have anti-skid spikes. These spikes must ensure safe and fully controllable driving on ice.

#### **51.03**

Spikes shall be made from solid steel only.

The maximum length of the spike, measured from the flat top surface of the fastening plate (washer): 28 mm.

Maximum thickness of the fastening plate (washer): 6 mm.

Minimum diameter of the top of the fastening plate: 15 mm and must be flat.

Maximum diameter on the base of the fastening plate: no limit.

The tubular gauge must have a maximum internal diameter (ID) of: 15 mm (unchanged).

#### **51.04**

No spikes shall exceed through a line, the vertical tangent on the extreme right hand side of the tyre.

#### **51.05**

The front tyre must have a maximum width of 100 mm and be fitted to a wheel rim of maximum diameter 23".

## 51.06

The rear tyre must have a maximum width of 100 mm and be fitted to a wheel rim of maximum diameter 21".

## 01.52 WHEELS, RIMS AND TYRES FOR TRACK RACING SIDECARS

- 52.01 Front wheel:** Minimum rim diameter: 18"  
Minimum diameter wheel spindle: 15 mm solid steel shaft permitted only.  
Minimum diameter of spokes: 3,5 mm M4, steel.  
Spoke lacing must cross twice.
- 52.02 Rear wheel:** Min. rim diameter: 18". Max. rim diameter: 22"  
Minimum diameter wheel spindle: 17 mm, solid steel shaft permitted only.  
Minimum diameter of spokes: 4 mm, M4, steel.  
Spoke lacing must cross twice.
- Maximum tyre width:** 100 mm

## 52.03

Spindle sleeves must be secured by supplementary locking, e.g. by castle nuts and split pin.

## 52.04

The minimum width between the wire spoke flanges at the hub must be 75 mm (see diagram R). The spoke holes must be countersunk on both sides.  
Plastic hubs are forbidden.

## 52.05 Sidecar wheel

**52.05.1** Maximum rim diameter: 16"

**52.05.2** Maximum wheel inclination of 30°, measured from the vertical to the inside (controlled by angle measuring instrument and spirit level).

**52.05.3** Position: One-sided wheel spindle diameter of 25 mm at the point of the highest moment of deflection; solid steel (see diagram Q). Or a diameter of 15 mm if supported on both sides of the wheel.

The sidecar wheel spindle must not be welded in position. It must be screwed on, for example, by collar or clamp, with at least three M8 screws.

The minimum length of the clamp is 100 mm. For construction using a clamp, protective devices against the loss of the component or failure of the clamp must be provided. Clamp construction in two planes is forbidden.

Wheel bearing: Safety device by castle nut and split pin.

## **52.09**

There is no restriction for the size or type of the front tyres. The tyre delivered by the manufacturer must not be subsequently altered.

## **01.53          ADDITIONAL SPECIFICATIONS FOR SIDECARS**

### **53.02**

The drive shall be transmitted to the ground only through the rear wheel of the motorcycle.

### **53.06**

Handlebars must be firmly secured to the forks. They must be at a height above the mid point in the seat.

The motorcycle must have a steering head which must be fitted like the handlebar, must not be attached to the unsuspended part of the front wheel suspension.

### **53.07**

To reduce the torque in the steering it is allowed to displace the front wheel and the rear wheel leaving a maximum width of 75 mm between them.

### **53.08**

The fuel tank and oil tank must be securely mounted and positioned behind the steering head.

### **53.09**

Articulated Sidecars are strictly forbidden.

### **53.10**

The Sidecar must be fixed to the motorcycle in at least three points, if it is not an integral part of the chassis.

The fixing points must not allow movement at the joints. If the angle of the inclination is changeable, it must be locked in such a way that the fixing method is completely secured and not only clamped on.

### **53.11**

The position of the engine is optional, except that it must be positioned in front of the rear wheel.

The centre line of the engine is determined by half its overall width measured across the motorcycle and shall not extend more than 160 mm beyond the centre line of the rear wheel of the motorcycle.

If the engine and gearbox are mounted on plates, the minimum thickness of the steel plates must be 4 mm, and 5 mm for light alloy plates.

### **53.14**

The minimum dimensions of a Sidecar available for passenger accommodation are:

Length: 1000 mm - Width: 400 mm

### **53.15**

The minimum ground clearance at the front edge of the Sidecar platform is 150 mm. The ground clearance of a laden Sidecar (with a rider and passenger) must not be less than 100 mm at any point.

### **53.16**

The steering of the front wheel must be accomplished without any intermediate articulated steering joints directly by a classic telescopic fork or a swinging arm fork with the wheel supported equally each side (long or short leading link type). All other types of front wheel steering and suspension are forbidden.

### **53.18**

The minimum height of the rider's seat shall be 400 mm, measured from the ground with the motorcycle in fully loaded condition.

### **53.20**

The distance between the tracks left by the centre lines of the rear motorcycle wheel and the Sidecar wheel must be at least 800 mm and not more than 1100 mm.

### **53.21**

On the opposite side of a Sidecar, the exhaust pipe must not extend more than 330 mm from the centre of the machine. On the other side, the exhaust pipe must not extend beyond the width of the Sidecar (see diagram L).

The furthest extremity of the exhaust pipe must not exceed the vertical line drawn at a tangent to the rear edge of the rear motorcycle tyre or the rear edge of the Sidecar platform whichever is shorter.

## **53.28**

The outside of the Sidecar wheel shall be provided with horizontal tubular protection (minimum tube diameter: 25 mm) fixed at the same height as the Sidecar wheel spindle. No component shall protrude beyond this protection.

## **53.29**

The inclination angle of the chassis must not exceed 15°, and the Sidecar wheel must not exceed 30° (See diagram L).

## **01.54        ADDITIONAL RULES FOR 1000CC TRACK RACING SIDECARS**

### **54.01        Definition**

**54.01.1**        To be deemed as eligible for competition in sidecar events on track racing circuits, the machine shall be in conformity with the following requirements:

**54.01.2**        The motorcycle must have three rolling wheels. The sidecar wheel must be on the left of the machine. The drive shall be transmitted to the track surface through the rear wheel of the motorcycle.

**54.01.3**        The motorcycle must at all time carry a driver and a passenger.

**54.01.4**        Brakes are not permitted.

**54.01.5**        Rear wheel suspension is optional.

**54.01.6**        The passenger must sit astride the motorcycle.

**54.01.7**        The motorcycle shall always race in a clockwise direction.

### **54.02        Dimensions**

**54.02.1**        The overall length from leading edge of the front tyre to outside of the rear mudguard must not exceed 2600 mm.

**54.02.2**        The overall width must not exceed 1500 mm.

**54.02.3**        The wheelbase, measured from the centre of the front spindle to the centre of the rear spindle, must measure between 1280 mm and 1800 mm.

**54.02.4**        The wheel track, measured between the centre lines of the track left by the rear and sidecar wheels, shall be a minimum of 800 mm and a maximum of 1100 mm.

**54.02.5**        The front and rear wheel must be aligned as such that the centre line of the tracks made by the motorcycle is proceeding directly forward, must be no further apart than 75 mm.



**54.02.6** The width of the running board on the right of the motorcycle must not exceed 400 mm.

**54.02.7** The angle of inclination of the main body of the motorcycle must not exceed 10° degrees from the vertical.

**54.02.8** The minimum ground clearance at any point of the sidecar shall be 75 mm unloaded.

### **54.03 Engine**

The engine capacity shall not exceed 1000cc. Engines may be bored up to 1045cc (no further tolerance).

**54.04 Minimum weight:** 180kg.

### **54.05 Fuel, Oil and Coolants**

Methanol or unleaded fuel, of a commercial make, is the only permitted fuel. The use of octane boosters is forbidden.

On liquid engines, an overflow pipe must direct any overflow coolant away from the rider and passenger and into a catch tank.

For environmental reasons, the rider/team/mechanic must at all times place a receptive container or an environmental mat under the motorcycle to catch waste oil and coolants, etc, when working in the pit-area during an event.

**54.05.1** The use of fuel additives is prohibited, with the exception of oil for two stroke engines.

**54.05.2** Fuel injection is permitted.

**54.05.3** Fuel tanks must be constructed of a material that neither shatter or splinter upon impact, and must be mounted to the rear of steering headstock.

### **54.06 Exhaust systems**

**54.06.1** Exhaust pipes and silencers may be of a “baffle” or “absorption” type and must fulfil the requirements concerning noise control.

An exhaust extraction (megaphone types) effect must not be caused by the positioning of any tapered, conical or other shaped parts in the silencer.

**54.06.2** The exhaust pipe must be fixed to the cylinder head and frame with a minimum of three (3) clips (the point of fixture at the cylinder head is considered as one clip). The silencer must be fixed to the frame with at least one clip.

Additionally, a second flexible coupling must be fitted from the first third of the silencer to the frame (steel cable of at least 3 mm Ø for reasons of safety) or a solid steel spring.

**54.06.3** Exhaust fumes must be discharged towards the rear but not in a manner as to raise dust, foul the tyres, or inconvenience a passenger, if there is one, or any other riders.

**54.06.4** The entire exhaust system must be contained within the fairing, to ensure that the exhaust system cannot come in contact with any rider, passenger, or motorcycle.

## **54.07 Wheels, Rims and Tyres**

**54.07.1** The only permitted rear tyre are the FIM Homologated Speedway tyres.

The rear tyre must be marked (by the Technical Steward).

Front tyre and sidecar tyre must be of a 'trial' type or 'enduro type' pattern.

Maximum sizes for rear wheel rim: 5.00"x19"

**54.07.2** The sidecar wheel diameter must be between 16 and 19 inches, and must camber inwards.

**54.07.3** The inside of spoked, cast or welded wheels must be covered with a disc or a shield.

**54.07.4** The sidecar wheel can be mounted with plates on both sides, in which case the spindle diameter is minimum 12 mm. If the sidecar wheel is mounted with a bracket on one side, the spindle diameter is minimum 20 mm.

**54.07.5** The rear and front wheel must be fitted with knockout spindles. The use of light alloys and titanium in the manufacturing of wheel spindles is forbidden.

## **54.08 Sidecar Platform**

**54.08.1** If the sidecar platform is not an integral part of the frame, the platform must be rigidly fixed to the motorcycle in at least four places.

**54.08.2** Any space between the sidecar platform and the rear wheel of the motorcycle must be covered to ensure that the passenger's hands and feet cannot be trapped in the driving chain or the rear wheel.

**54.08.3** The sidecar wheel must be contained within a continuous 25 mm horizontal crash bar, fixed rigidly to the sidecar platform at sidecar floor height.

Any open area in the sidecar platform inside the continuous crash bar, and on the running board on the near-side, must be filled with a suitable material to prevent either the rider or passenger from trapping their feet.

## **54.09 Dirt Deflectors, Mudguards, Fairings**

**54.09.1** A dirt deflector is compulsory and must be homologated by the FIM. **See Art. 58.03.1 for dirt deflector details.**

**54.09.2** The Dirt Deflector arm must be positioned to ensure that the blade and flap are correctly positioned behind the rear tyre.

**54.09.3** The rear mudguard must be fitted and extend from the rear seat to a maximum of 150 mm from the ground with the sidecar occupied or with ballast.

**54.09.4** The outside of the sidecar wheel and tyre must be covered by a non-rotating shield or fairing. This fairing must be securely fixed to the sidecar and outside of the crash bar.

**54.09.5** All fairings and nose cones must be constructed of fibreglass, plastic, or similar material. They must be smooth, free of any sharp or protruding edges, and must not provide a danger to any other competitor. The minimum clearance between streamlining and the ends of the handlebars or their attachments is 30 mm with the front wheel in any position. No aero foils or similar devices are permitted.

**54.09.6** No part of any nose cone or fairing may extend beyond a vertical line drawn through the leading edge of the front tyre. No part of the sidecar fairing may extend beyond a vertical line drawn at a tangent to the rear edge of the back tyre.

## **54.10 Frame**

The use of titanium and composite materials in the construction of a frame and swing-arm is completely forbidden

**54.11** An efficient steering damper must be installed.

## **01.55 NUMBER PLATES**

### **55.01**

For Speedway and Ice racing, number plates are not required. The rider must display his number on his person.

#### **55.01.1 Individual Speedway World Championship Grand Prix**

For the Speedway Grand Prix machines, two side-number plates are required (see diagram O).

Number plates must be made from a rigid and solid material with minimum measurements of 150 mm x 150 mm. The plates must not curve more than 50 mm out of a true plane or be covered or bent (see diagram O).

One number plate must be fixed on each side of the motorcycle facing outwards. Each number plate must be fixed in such a manner as to be clearly visible and they must not be masked by any part of the motorcycle or by the rider when seated in the driving position.

The number plates must fit in the space between the upper part of the rear sub-frame, the bottom edge of the rear mudguard and the lifting handle.

The figures must be clearly legible and like the background must be painted in matt colours to avoid reflection from light. The minimum dimensions of the figures being:

Height of figure:	150 mm
Width of figure:	80 mm
Width of stroke:	25 mm
Space between 2 figures:	15 mm

The colours must be matt, following the RAL colour table. Black (Ral 9005) on a white (Ral 9010) coloured background.

The English form for numbers must be used. That is a single vertical line for the "one" and a simple sloping line without a horizontal line for the "seven" (see diagram O)..

No other number plates or markings on a motorcycle liable to cause confusion with the number will be allowed and must be removed before the start of a competition.

#### **55.01.2 For all other Individual Speedway or Ice Racing World Championship Events**

Number plates are not required. Riders are obliged to wear a riding jacket, displaying their number.

#### **55.01.3 Long & Grass Track World Championship**

For Long & Grass Track machines, three number plates are required. One plate must be fixed to the front, inclined not more than 30° towards from the vertical.

Two other number plates must be placed vertically, one on each side of the motorcycle facing outwards. These must be fixed in such a manner as to be clearly visible and they must not be masked by any part of the motorcycle or by the rider when seated in the driving position. (See diagram K).

#### **55.02 Sidecars**

For Sidecars, three number plates are required. They must be fitted to the motorcycle in such a manner that they cannot be masked by any part of the motorcycle, nor the rider and/or passenger. The sidecar plate must be fixed parallel to the sidecar wheel (refer to Diagrams L and O for dimensions and fixation points).

#### **55.03**

They must be rectangular shape and made from a rigid and solid material with minimum measurements 285 mm x 235 mm. (See diagram 0).

#### **55.04**

The plates curved not more than 50 mm out of a true plane must not be covered or bent.

#### **55.05**

One plate must be fixed to the front inclined not more than 30° rearwards from the vertical. The others must be placed vertically one on each side of the motorcycle facing outwards. They must be fixed in such a manner as to be clearly visible and they must not be masked by any part of the motorcycle or by the rider when seated in the driving position.

#### **55.06**

In place of separate plates, a space of equivalent size (in matt colours) can be painted or fixed on the bodywork.

#### **55.07**

The figures must be clearly legible and like the background must be painted in matt colours to avoid reflection from sunlight. The minimum dimensions of the letters being:

Height of figure:	150 mm
Width of figure:	80 mm
Width of stroke:	25 mm
Space between 2 figures:	15 mm

#### **55.08**

The English form for numbers must be used. That is single vertical line for the "one" and a simple sloping line without a horizontal line for the "seven".

#### **55.09**

All other number plates or markings on a motorcycle liable to cause confusion with the number must be removed before the start of a competition.

#### **55.12 Number Plate Colours**

The colours must be matt, following the RAL colour table, i.e.:

Black	9005
Blue	5010
Yellow	1003
Red	3020
Green	6002

White 9010

**55.12.1** For Long Track and Grass Track: yellow background, black numbers.

**55.12.2** For 1000 cc Sidecars: black background, white numbers.

**55.12.3** For 125cc Grass Track motorcycles: green background, white numbers

**55.12.4** For 250cc Long Track and Grass Track: blue background, white numbers.

### **55.13**

In case of a dispute concerning the legibility of numbers, the decision of the Technical Steward will be final.

## **01.56 OIL CATCH TANKS**

All motorcycles with a closed oil system must be equipped with an oil catch tank with a minimum volume of 300 cc to be fitted over the breather pipe on the engine.

All motorcycles with a total loss oil system must be equipped with an oil catch tank with a minimum volume of 300 cc to be emptied after each heat or race.

## **01.58 SPECIFICATIONS FOR TRACK RACING MOTORCYCLES**

### **58.01 General**

Machines must be fitted with a single cylinder 4-stroke engine with a maximum capacity of 250cc or 500 cc, 4 valves maximum, fitted with one (1) carburettor with a diameter of 34 mm and one spark plug. **For 500 cc Sidecars, a diameter of 38 mm is prescribed.**

### **58.02 Carburation instruments**

A section of the carburation instrument induction tract must have a constant, circular shape with a ~~maximum~~  $\text{\O}$  of 34.00 mm (+ 0.1 mm). **For 500cc Sidecars the section is:  $\text{\O}$  38 mm (+ 0.1 mm).** Only one (1) single fuel nozzle is permitted. No other additions are permitted in the air induction tract.

On the air intake side, this circular section will be measured from the slide/throttle valve edge over a minimum length of 5 mm.

On the engine side, this circular section will be measured from the slide/throttle valve edge, over a minimum length of 25 mm.

On the engine side, an additional hole (maximum  $\text{\O}$  6 mm) is permitted to be used for engine starting purposes (choke). (See diagrams G, H, K, L)

- For two-valve engines: An additional jet and/or an additional hole (maximum diam. 2 mm) on the engine side is authorized to improve the engine's response at lower rpm.

### **58.03 Dirt Deflector**

Dirt deflectors are compulsory in 250cc/500cc Speedway, Long Track, Grass Track and Sidecars.

All dirt deflectors must be homologated by the FIM.

#### **58.03.1 Dirt Deflector-Specifications**

The dirt deflectors used must be within these specifications and must be fitted to the machine and presented at the technical verification.

**58.03.2** The dirt deflector arm(s) and pivot mechanism must be constructed of the highest grade materials, permitting minimal distortion and maximum durability under all riding conditions.

**58.03.3** The dirt deflector flap holder must be constructed of a non-metallic material (except **for Longtrack and Sidecars**).

The dirt deflector 'flap' must be easily replaceable and constructed of a resilient, non-metallic material. The dirt deflector flap must remain effective under all track surface and wind conditions.

The dirt deflector flap must be shaped and positioned in such a way that the distance of the upper flap edge to the complete tyre tread width is 18 mm (+/-5 mm). The opposite lower edge shall be 35 mm maximum from the track surface over an equal distance.

Outside of this centre section, the deflector flap lower edge may slope up to a maximum of 50 mm above the track surface.

**58.03.4** The deflector flap must be set at an angle, between 30° degrees and 50° degrees maximum (depending on the FIM homologated design) to the track surface, measured on the longitudinal centre line of the machine.

A manufacturer must show the designed angle on any published instruction. The permitted fitting tolerance on the designed angle is +/- 5° (degrees) (see also Art. 58.03.9 and Diagram S).

**58.03.5** The deflector flap must not be less than 250 mm and not more than 300 mm in overall width. The flap centre must be positioned within a 10 mm off-set to the left of the tyre centre line, in the normal riding position.

The flap holder must not be less than 100 mm and not more than 160 mm in overall width.

**58.03.6** No part of the dirt deflector shall be more than 75 mm behind the vertical tangent to the rearmost point of the tyre when fitted in the normal operating position.

**58.03.7** The dirt deflector arm(s) must be able to pivot a minimum of 25° (degrees) in an upward direction to allow safe operation when the front wheel lifts.

**58.03.8** Any pivot arrangement must have its centre of rotation a maximum of 70 mm from the rear wheel axis.

**58.03.9** A mechanism must maintain constant function of the pivot arrangement and be able to return the dirt deflector 'flap' to its normal operating position with minimal delay.

To measure the tension provided by the mechanism of the dirt deflector, a vertical balance shall be used to measure an equivalent minimum pre-load of 2.5 kg for dirt deflectors used in Speedway and 8 kg for dirt deflectors used for Long Track, Grass Track and 1000c Sidecars.

The vertical balance must be attached to the outer edge of the dirt deflector flap in line with the centre of the rear tyre.

**58.03.10** All measurements are taken with the machine in a vertical position, with the tyres normally inflated without a rider.

**58.03.11** The complete dirt deflector must be homologated by the FIM. The manufacturer must supply drawings and photographs of the dirt deflector at the time of homologation. The manufacturer must engrave on each dirt deflector: FIM DD/Year/Homologation number (issued by the FIM).

**The FIM reserves the right to sample dirt deflectors at any time to compare with the original homologated dirt deflector.**

The inter-face of the dirt deflector may be altered to allow a correct assembly to a particular frame construction; however the dirt deflector must retain its normal function.

Subsequent to FIM homologation, the dirt deflector's design (i.e. flap, flap-holder, arm(s) or pivot point) must not be altered in any way. The only changes allowed are engineering and/or production enhancements, by written document to the FIM.

## **01.59 SPECIFICATION FOR ICE RACING MOTORCYCLES**

Only 2-valve engines are allowed.

## **01.60 CARBURETTORS FOR GRASS TRACK MOTORCYCLES**

The carburettor must be fitted with an efficient cartridge type air filter.

## **01.63 FUEL AND OIL**



All four stroke single cylinder engine machines must use pure methanol, with the exception of 'Flat Track' motorcycles (see Art. 85.08). All other machines must use pure methanol or unleaded petrol as defined in art. 63.01.

### 63.01 Physical properties for unleaded fuel

63.01.1 Unleaded petrol must comply with the FIM specification.

63.01.2 Unleaded petrol (incl. E10) will comply with the FIM specification if:

(a) It has the following characteristics:

Property	Units	Min.	Max.	Test Method
RON		95.0	102.0	ISO 5164
MON		85.0	90.0	ISO 5163
Oxygen	% (m/m)		3.7	ISO 22854
Nitrogen	% (m/m)		0.2	ASTM D 4629
Benzene	% (V/V)		1.0	ISO 22854
Vapour pressure (DVPE)	kPa		95.0	EN 13016-1
Lead	g/L		0.005	EN237
Manganese	g/L		0.005	EN16136
Density at 15°C	kg/m <sup>3</sup>	720.0	775.0	ISO 12185
Oxidation stability	minutes	360		ISO 7536
Existent gum	mg/100 mL		5.0	ISO 6246
Sulphur	mg/kg		10.0	ISO 20846 or 20884
Copper corrosion	rating		class 1	ISO 2160
Distillation:				
E at 70°C	% (V/V)	24.0	52.0	ISO 3405
E at 100°C	% (V/V)	46.0	72.0	ISO 3405
E at 150°C	% (V/V)	75.0		ISO 3405
Final Boiling Point	°C		210	ISO 3405
Residue	% (V/V)		2.0	ISO 3405
Appearance	Clear and bright			Visual inspection
Ethanol (1)	% (V/V)		10	ISO 22854
Olefins	% (V/V)		18.0	14517 or 15553
Aromatics	% (V/V)		35.0	14517 or 15553
Total di-olefins	% (m/m)		1.0	GCMS/HPLC

(1) Shall conform to EN 15376

**All methods include a precision statement. In cases of dispute, the procedures resolving the dispute and interpretation of the results based on test method precision, described in ISO 4259, shall be used.**

(b) The total concentration of naphthenes, olefins and aromatics classified by carbon number must not exceed the values given in the following table:

%	C4	C5	C6	C7	C8	C9+
Naphthenes	0	5	10	10	10	10
Olefins	5	20	20	15	10	10

Aromatics	-	-	1.2	35	35	30
-----------	---	---	-----	----	----	----

The total concentration of bicyclic naphthenes and bicyclic olefins may not be higher than 1% (m/m). The test method used will be gas chromatography.

(c) Only the following oxygenates are permitted:

Methanol. Ethanol. Iso-propyl alcohol. Iso-butyl alcohol. Methyl tertiary butyl ether. Ethyl tertiary butyl ether. Tertiary amyl methyl ether. Di-isopropyl ether. N-propyl alcohol. Tertiary-butyl alcohol. N-butyl alcohol. Secondary-butyl alcohol.

(d) Manganese is not permitted in concentrations above 0.005 g/l. For the present this is solely to cover possible minor contamination by other fuels. The fuel will contain no substance that is capable of an exothermic reaction in the absence of external oxygen.

Lead replacement petrols, although basically free of lead, are not an alternative to the use of unleaded petrol. Such petrols may contain unacceptable additives not consistent with the FIM Fuel Regulations.

**63.01.3** Ethanol E85 will comply with the FIM specification if:

(a) It has the following characteristics:

Property	Units	Min.	Max.	Test Method
RON		95.0	110	ISO 5164
MON		85.0	100	ISO 5163
Vapour pressure (DVPE)	kPa	35.0	95.0	EN 13016-1
Lead	g/L		0.001	ICP-OES
Manganese	g/L		0.001	ICP-OES
Oxidation stability	Minutes	360		ISO 7536
Existent gum	mg/100 mL		5.0	ISO 6246
Sulphur	mg/kg		10.0	ISO 20846 or 20884
Copper corrosion	Rating		class 1	ISO 2160
Distillation:				
Final Boiling Point	°C		210	ISO 3405
Residue	% (V/V)		2	ISO 3405
Appearance	Clear and bright			Visual inspection
Ethanol + higher alcohols	% (V/V)	75		EN 13132 or 14517
Higher alcohols (C3-C8)	% (V/V)		2.0	EN 13132 or 14517
Methanol	% (V/V)		1.0	EN 13132 or 14517
Ethers (5 or more C atoms)	% (V/V)		5.2	EN 13132 or 14517
Unleaded petrol as specified in 2.10.1.2	% (V/V)	14	25	
Water	% (V/V)		0.3	EN 12937
Inorganic chloride	mg/L		1	EN 15484
Acidity	% (m/m)		0.005	EN 15491

(as acetic acid)	(mg/L)		(40)	
------------------	--------	--	------	--

### **63.02 Oil**

For oil used in two stroke mixtures, the following tolerances on the fuel specifications will be allowed:

• Density at 15°C	Plus/minus 30 kg/m <sup>3</sup>
• Distillation residue	Not controlled

Any infringement of the fuel specifications will automatically result in the exclusion of the competitor from the entire meeting (see also Sporting Code Art. 140.1). The result of the competitors' fuel sample analysis (A or B Sample) more favourable to the competitor will be taken into account (See also Art. 63.05.3).

If the fuel available locally for the event is not of a sufficient quality for use by competitors, the FMN of the organising country must ask the FIM for a waiver in order to enable the use of fuel not corresponding to the characteristics defined above.

### **63.03 Air**

Only ambient air may be mixed with the fuel as an oxidant.

### **63.04 Primary Tests**

**63.04.1** The FIM may require tests of fuels to be administered before, or at the time of delivery to, an event at which such fuels are to be used.

**63.04.2** The FIM may request any person or organisation, being a potential Official Supplier of fuel, to submit a sample for testing for conformity with the fuel specifications.

### **63.05 Fuel Sampling and Testing**

1) The FIM-appointed Official has the sole responsibility for the management and supervision during the taking of fuel samples.

2) The preferred fuel test method is the Gas chromatography or GC Fingerprint method.

Gas chromatography (GC) is an analytical technique for separating compounds based primarily on their volatility and polarity. Gas chromatography provides both qualitative and quantitative information for individual compounds present in a sample. The Gas chromatography is widely used for the analysis of fuels.

3) If other test methods are required, fuel samples are transported to the appointed laboratory by a nominated courier, using the appropriate containers.

4) Riders selected for fuel controls are directed with their motorcycles to the inspection area.

- 5) Only new sample bottles are used to transfer the fuel samples.
- 6) The fuel to be tested is transferred directly from the selected fuel tank into three vials (3 small sample containers), marked A, B and C and identified by reference to the motorcycle from which the sample was taken. The bottles are closed, sealed and labeled by the FIM appointed Official.
- 7) The Fuel Sample Declaration form is filled out immediately. A responsible team member signs this declaration, after verifying that all the information is correct.
- 8) Samples A and B are given to the appointed laboratory staff, present at the event for analysis or transported to the appointed laboratory by a nominated courier. Sample B will be kept by the laboratory staff as a reserve sample, to be used for a second analysis if required. All samples are accompanied by a copy of the Fuel Sample Declaration form. Costs for the analyses of sample A and B are paid by the FIM.
- 9) Sample C is handed over to the FIM, accompanied by a copy of the Fuel Sample Declaration form, for safeguarding in case of protests and/or a request for a counter-expertise by the FIM appointed laboratory. Costs for the analyses of sample C are paid by the team concerned.
- 10) As soon as possible after completing the testing, the laboratory technician supplies the results of the fuel sample analyses directly to the FIM appointed Official, with a copy to the rider, the relevant Commission Director and CTI Secretariat (via [ccp@fim.ch](mailto:ccp@fim.ch) and [cti@fim.ch](mailto:cti@fim.ch)).
- 11) In the case of non-conformity of the fuel, the FIM appointed Official must notify the results to, the FIM, the Race Direction (or the International Jury) and the rider/ team representative concerned.
- 12) Failure of the sample to conform to the FIM fuel specifications results in the disqualification of the competitor. The result of the competitor's fuel sample analysis ("A" or "B" sample) more favourable to the competitor is taken into account.
- 13) Within 48 hours of the receipt of the notification of the results from the analysis of sample A and/or B, the team must notify the FIM and the FIM-appointed Official if a counter-expertise of sample C is requested.
- 14) The Race Direction (or the International Jury) takes a decision, immediately following the notification of the results of the final expertise.
- 15) Any appeal against the decision of the Race Direction (or the International Jury) is heard by the FIM Stewards appointed for the event. This takes place after the C sample has been analysed. For events without a Panel of Stewards, the appeal is lodged before the CDI.



# FIM WORLD CHAMPIONSHIPS AND PRIZE EVENTS

## Fuel Sample Declaration Form

FUEL SAMPLES TAKEN ON ..... /..... / ..... FOR LABORATORY ANALYSIS

Tech inspection, or practice Race N°:	<i>Sample "A"</i>	
	Can Label N°	Can Seal N°
Rider:	<i>Sample "B"</i>	
	Can Label N°	Can Label N°
	<i>Sample "C"</i>	
	Can Label N°	Can Label N°

MOTORCYCLE  
MAKE: \_\_\_\_\_

TEAM: \_\_\_\_\_

The above listed details refer to fuel samples taken from the fuel tank of the motorcycle specified after the race whilst in the Check Area for a period of 30 minutes.

Sample "A" and "B" will go to the laboratory appointed by the FIM for analysis. Sample "C" will be safeguarded by the FIM in case a counter-expertise is required.

As a responsible member of the team named on this sheet, I,

(print name): \_\_\_\_\_

have controlled the serial numbers of can seals and serial numbers of can labels and hereby certify the accuracy of the listed information.

Time: \_\_\_\_\_

(Signature)

Position in team: \_\_\_\_\_ (OWNER/MANAGER/MECHANIC)

**01.65            EQUIPMENT AND PROTECTIVE CLOTHING**  
**Clothing and footwear**

**65.01            During practice and racing**

**Riders must wear protective clothing, all made of materials designed to provide appropriate protection.**

**As a minimum, protective clothing should consist of a one-piece overall (as used in road racing) and footwear.**

**The overall may consist of an upper and lower segment joined by a zip mechanism or similar. The use of elastic-stretching material inserts is permitted under arms, behind the knees and in the groin to allow for freedom of movement when worn.**

**The overall may consist of leather material or non-leather materials with equivalent protective properties to leather, either of which must be formed of material being of 1.0mm in thickness. The use of nylon/lycra material is forbidden.**

**Repaired overalls are acceptable provided that the repair guarantees protection to the same standard as the original garment.**

**The Chief Technical Steward has to right to refuse any temporary repairs is not deemed to provide the same protection as the original garment.**

**A certificated back and chest protector of composite material should be worn at all time and is highly recommended.**

**Additional body protection must be worn either incorporated within the clothing or worn separately over appropriate undergarments.**

**65.01.1        If incorporated within the clothing it must include the use of padding made of leather, or enclosed plastic foam of at least 8mm thickness covering the following areas: shoulders, elbows, both sides of the torso (chest & back), hip joints and knees.**

**65.01.2        If not incorporated within the clothing alternatively “body armour” approved for use in track racing disciplines may be used. This should comprise as a minimum of ribbed panels of moulded plastic, not necessarily in conformity with article 65.07, minimum thickness of 2mm. covering the following areas: shoulders, elbows, both sides of the torso (chest & back), hip joints and knees.**

**65.02**

**Undergarments, if used, may be either of the "Nomex®" type, silk or cotton. The use of synthetic materials, which may melt and could cause damage to the riders' skin is forbidden.**

### **65.03**

**Footwear, in a good condition, made of leather or an approved substitute and be of a minimum height of 30 cm to provide together with the suit, complete cover below the neck.**

### **65.04**

**Riders and Passengers must wear gloves made of leather or other materials giving equivalent properties corresponding to Article 65.07.**

### **65.05**

**Riders and Passengers must wear face shields or goggles that are shatter resistant.**

### **65.06 For Ice Speedway**

**65.06.1 Riders must wear a certificated back and chest protector of composite material. Clothing, whether made of leather or non-leather, conforming to Article 65.07 must incorporate extra "body protection" for collarbones and upper arms in addition to shoulders, elbows, both sides of the torso (chest and back), hip joints and knees in accordance with Art. 65.01.1.**

### **65.06.2**

**Cotton undergarments only must be worn. Any other clothing worn under or over the race suit must be made of cotton only. Garments of wool or synthetic fibres are forbidden.**

### **65.06.3**

**At least 3 studs must be fitted to the sole of the rider's right boot.**

### **65.07 Material equivalent to leather**

The following characteristics of the material must be at least equivalent to 1.5 mm of cowhide (not split leather):

- 65.07.1** Fire retardant quality
- 65.07.2** Resistance to abrasion
- 65.07.3** Coefficient of friction against all types of asphalt
- 65.07.4** Perspiration absorbing qualities
- 65.07.5** Medical test - non toxic and non-allergenic
- 65.07.6** Fabric of a quality that does not melt.
- 65.07.7** Clothing in material other than leather must bear a sticker or label which says "in conformity with the FIM rules". This label must be sewn or attached to the clothing in a permanent way.

## **65.08 Approval**

The clothing manufacturer is responsible for ensuring that the products and materials that carry his name conform to these rules. The FIM cannot be held liable for any injuries that a rider or passenger may sustain from their use.

## **01.67 WEARING OF HELMETS**

It is compulsory for all participants taking part in practice and races to wear a protective helmet. The helmet must be properly fastened, be of a good fit, and be in good condition. The helmet must have a chin strap type 'retention system'.

Helmets constructed with an outer shell of more than one piece are permitted, provided that, in case of emergency; they can be quickly and easily removed from the rider's head by releasing or cutting the chin strap only.

All helmets must be marked with one of the official international standard marks mentioned in Art. 01.70 or the Approval Mark (stamp) of the FMN of the rider. Helmets marked by an FMN must comply with one of the International Standards listed in Art. 01.70 before approval by an FMN.

Failure to observe the above rules will entail exclusion.

## **01.69 HELMET OPERATIVE INSTRUCTIONS**

### **69.01**

Scrutineers, under the supervision of the Chief Technical Steward, may check prior to practice and the races that all helmets meet the technical requirements.

### **69.02**

If a helmet does not meet the technical requirements and is found to be defective, the Technical Steward must remove all approval marks and retain the helmet until the end of the event. The rider must submit another helmet for approval by the Technical Steward. After an accident involving impact, the helmet must be presented to the Technical Steward for examination (see also Art. 77.02.14).

### **69.03**

All helmets must be intact and no alteration must have been made to their construction. After an accident involving impact the helmet must be presented to the Technical Steward for examination.

### **69.04**

The Chief Technical Steward and/or the Technical Steward may perform the following checks before the rider is permitted to take part in practice of the race:



- 69.04.1** That the helmet fits well on the rider's head,
- 69.04.2** That it is not possible to slip the retention system over the chin, when fully fastened,
- 69.04.3** That it is not possible to pull the helmet over the rider's head by pulling it from the back of the helmet.

## **01.70 RECOGNISED INTERNATIONAL HELMET APPROVAL MARKS**

- Europe ECE 22-05 (P ou J)
- Japan JIS T 8133
- USA SNELL M 2010

(see International Helmet Standards in diagram section)

## **01.71 EYE PROTECTION**

The use of glasses, protective goggles as well as helmet visors and 'tear off's' is permitted. The material used for eye protectors and glasses must be made of shatter-proof material. Helmet visors must not be an integral part of the helmet.

Eye protectors which cause visual disturbance (scratched etc.) must not be used.

## **01.75 BADGE OF THE FIM**

Under certain circumstances the FIM may permit the use of the FIM badge on certain equipment in order to show that the latter conforms with the standards laid down by the FIM. When this authorisation is granted and provided the equipment on which it appears is in good condition, the badge is then the guarantee of the conformity with the standard set by the FIM.

## **01.77 CONTROL**

### **77.01 Verification**

#### **General**

**A rider is at all times responsible for his machine.**

**77.01.1** The Chief Technical Steward must be in attendance at an event 1 hour before technical verifications are due to begin. He must inform the Clerk of the Course, Jury President and CTI Delegate, if present, of his arrival.

**77.01.2** He must ensure that all technical stewards appointed for the event carry out their duties in a proper manner.

**77.01.3** He shall appoint the technical stewards to individual posts for the race, practices and final control.

**77.01.4** Technical inspections will only be carried out when the technical specification form of the motorcycle has been presented by the Organiser.

**77.01.5** The rider, or his mechanic, must be present with the machine for technical control within the time limits stated in the Supplementary Regulations. On request of the Technical Steward, the riders must present themselves to the technical verification.

**77.01.6** The Chief Technical Steward must inform the Clerk of the Course/ Jury President of the results of the technical control. The Chief Technical Steward will then draw up a list of accepted machines and submit this list to the Clerk of the Course.

**77.01.7** The Chief Technical Steward has the right to look/ inspect any part of the motorcycle at any time of the event.

## **77.02**

Any rider failing to report **as required by the provisions below** may be excluded from the meeting. The Clerk of the Course may **prohibit** any person who does not comply or any rider who **could** be a danger to other participants or to spectators, from taking part in the practising or in the races.

**77.02.1** The technical control must be carried out in conformity with the procedure and times fixed in the CCP Rules and the Supplementary Regulations of the event. The maximum number of persons permitted to be present at the technical verification is the rider, plus two others. For Team events, the Team Manager is also allowed to attend.

**77.02.2** The rider or mechanic must present a clean motorcycle in conformity with the FIM rules. The Technical Steward must fill in the technical card which must be signed by the rider. The fuel tank must be empty.

**77.02.3** The rider must present his equipment. The helmet must be marked.

**77.02.5** The exhaust silencer must be marked with paint. The sound level will be recorded in the technical card.

**77.02.6** The motorcycle must be weighed and the weight recorded in the technical card.

**77.02.7** An overall inspection of the motorcycle must be carried out in conformity with the FIM rules. Accepted motorcycles will be marked with paint or a sticker.

**77.02.8** The rider is permitted to use whichever motorcycle he chooses from the accepted motorcycles. He may also use the motorcycle of another rider.

**77.02.11** During the event, the technical steward must control all machines and equipment. This control must be made before the machines enter onto the track.

**77.02.12** As soon as a rider has finished all his heats, all machines must be immediately placed in a closed park where they must remain for 30 minutes, in case of a protest or should further examination be required.

Competitors must retrieve their machines within 30 minutes after the opening of the closed park area, except for the machines which are chosen for disassembly. After this time limit, the closed park officials will no longer be responsible for the machines left behind.

If required, a sound level control may be carried out before the machines are placed in the closed park.

**77.02.14** If a motorcycle has been involved in an accident, the Technical Steward must check the machine to ensure that no technical defect has occurred as a result.

If the helmet is clearly defective, the technical steward must retain this helmet. The organiser must send this helmet, together with the accident and medical report (and pictures and video, if available) to the Federation of the rider. If there are head injuries stated in the medical report, the helmet then must be sent to a neutral institute for examination.

## **77.05 Dangerous machines**

If, during practice or the race, a Chief Technical Steward finds that a machine is defective and might constitute a danger to other riders, he must immediately notify the Clerk of the Course or his deputy. It is their duty to exclude such a machine either from the practice or from the race itself.

## **01.78 SCRUTINEERING GUIDELINES FOR TRACK RACING TECHNICAL STEWARDS**

- Make sure all necessary measures and administrative equipment are in place at least 1/2 hour before the start of the technical control (see separate list) is due to open (time in Supplementary Regulations).
- Decide prior to the technical control who is doing what and note decisions. "Efficiency" must be the watchword. Always keep cheerful and remember the reasons for scrutineering: SAFETY AND FAIRNESS.
- Be well informed. Make sure your FMN has supplied you with all technical "updates" that may have been issued subsequent to the printing of the Technical Rule Books. Copies of all homologation documents must be in your possession.
- Inspection must take place under cover with a large enough area (min. surface 50 sq. metres).

- Inspection area must be supplied with the necessary equipment, including tables, chairs, electric light and power outlet.
- Weighing apparatus must be accurate and practical. Certified master weights and their certificate must be available for verifying.
- Prepare before the START of the competition, a closed and guarded area (closed parc/parc-fermé).
- Rules regarding sound level and -measurement must be respected.

<b><u>Procedures</u></b>	<b><u>Minimum number of Scrutineers required</u></b>
• Checking of documentation (entry forms, licence, helmet, clothing, etc.).	1 person
• Sound level test, silencer marking.	2 person
• The machine weight (with empty tank):	1 persons
• Machine inspection (with strict check of carburettor). Compliance with rules and safety. Items must be marked.	2 persons
• Scrutineers can have different tasks, but the team of scrutineers must have a minimum of 3 persons. At least one (1) person must be a holder of an FIM <b>SENIOR</b> Technical Stewards Licence.	

**Technical control on day before or on the same day of the start of OFFICIAL PRACTICE:**

- Minimum time: 1/2 hour
- Minimum safety checks, marked items and weight. 2 persons
- Free use of the weighing equipment by all teams.

**Technical control on day before or on the same day of the start of the RACE:**

- Minimum time: 1 hour
- Free use of the weighing equipment by all teams.
- General machine inspection, helmet and clothing.

**Technical control after the race:**

- After the race, ensure that ALL machines go directly to the Closed Parc and are retained 30 minutes.
- Post race inspection (machines weighted with tank empty).

**Verification:**

- According to protest or Jury Decision

**List of Tools and Documents**

Tools :

- Revolution meter
- Sound meter and calibrator
- Durometer for tyre control ('Shore' hardness gauge)
- Slide calliper (for verifying engine capacity, carburettor diameter, etc.)
- Depth gauge
- Steel measuring tape
- Arrangement for measuring ground clearance
- Seals
- Weighing apparatus (to be furnished by the Organiser); set of weights to adjust the scales (180 kg), vertical balance (0 –10 kg)
- Tools for measuring the engine capacity
- Lampoil tester for measuring the cylinder capacity
- Colour for marking parts
- Label, temperature stable, if taken for marking silencer
- Magnet for testing titanium
- Adequate fuel sample bottles
- PC with CD Drive + **'Windows 7' recommended**
- Printer, etc. are recommended
- Calculator

Documents :

- Supplementary Regulations
- FIM Technical Rules - current year
- FIM Rules of the discipline concerned, e.g. CCP, CTI
- FIM Sporting Code
- Homologation papers, if necessary, for the discipline
- Writing material
- Technical Control Forms



<b>FIM Technical Report</b> <b>Machine Examination in Track Racing</b>
---

**Event**

Title of the event:	IMN N°:
Location:	Country:

**Rider Information**

Name:	First name:
Nationality:	FMN:
Start N°:	FIM Licence N°:

**Machine Information**

Machine	Engine Make	Engine N°	Frame Make	Frame N°	Dirt deflector	Ignition cut of	Weight
1							
2							
3							

**Carburettor**

**Silencer information**

Machine	Carburettor Make	Section diameter mm	Silencer Make	Serial N°	dB/A output
1					
2					
3					

**Protective Clothing**

**Equipment**

Protective clothing	Approval Mark:	N° Helmets	Helmets make	Approval Mark
MX-Style:		1		
Leathers:		2		
		3		
		4		

**During and after the Event**

Machine weight:	Heat N°:		
Kg:			
Engine Capacity:	Bore:	Stroke:	Vol <sup>cc</sup> :
		Environment mat	
Name of the FIM Chief Technical Steward:			
International Official's Licence N°:			

Acceptance of a machine for competition does not preclude the possibility of further post-race control to ensure compliance with the FIM Technical rules for Track Racing.

Acceptance stamp of the FIM Chief Technical Steward:	I hereby declare that information's given here above is accurate in every respect
Date:	
Signature:	Rider's signature

## **01.79            SOUND LEVEL CONTROL**

Sound will be controlled to limits as stated in Article 79.11.

### **79.01            The '2 metre max' method – The new test method to verify the sound levels**

In order to pursue the measures taken to reduce the sound level in favour of environment and in the framework of the 'RIDE QUIET' campaign, a new method for measuring the sound level called '2 metre max' will progressively be applied as from 2010 in all 'all-terrain' disciplines (and more specifically in Motocross, Enduro and Track Racing).

#### **WHAT DOES IT CONSIST OF?**

The 2 metre max method shows a very good correlation between the sound power level (LwA) issued by motorcycles in full acceleration, and the maximum sound pressure levels measured at proximity of the same motorcycles, with engines at idle and quickly taken to their maximum rotational speeds.

The technical specifications and the resources to initiate the application of this new method, for the use of the technical stewards and officials are mentioned in Art. 79.01 of these Technical Regulations. This article will detail the "2metre max" method, the sound levels, the indispensable tools, but also the tolerances applied in 2010 - use of the old method as default, etc.)

Only the sound levels measured with the '2 meter max' method will be considered by the technical stewards and the jury of the event to decide whether the motorcycle is in conformity with the maximum sound levels authorised.

#### **THE 2 METER MAX METHOD - IN FOCUS**

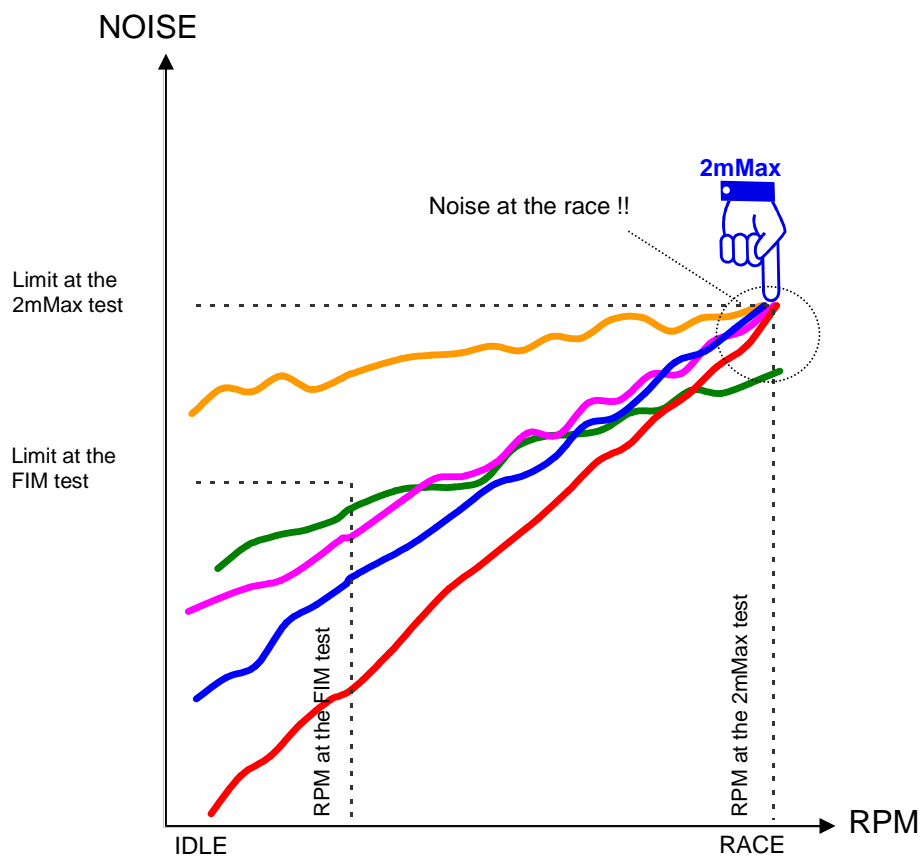

## THE OPERATING PROCEDURE

The '2 metre max' method will consist in quantifying not only the sound level produced by the silencer of the exhaust, but the maximum global sound level achieved by the motorcycle when the engine rpm's are raised to the maximum engine speed, limited by

- ⇒ natural regulation for 2T, or
- ⇒ rev limiter for 4T.

For 250cc and 500cc (4 stroke) engines used in Speedway, Long track and Ice Racing, without rev limiter, it would be advisable to limit the full open the throttle for 1 or 2 seconds maximum.

## THE PREPARATION OF THE SOUND METER

For all FIM Championship-and Prize events, a sound meter Class 1 (type 1) is required to measure the sound levels. For all other Championships, a sound meter of Class 1 or 2 (type 1 or 2) is required

- Activate the 'A' weighing
- **FAST** time weighting must be activated
- Select range High **80~130 dB**



- Calibrate the sound meter at 93,5 dB or 113.5 dB to take into account the incidence of the wind foam ball
- Position the wind foam ball on the microphone
- Activate the function MAX MIN – set on **MAX**

## **THE SET UP OF THE SOUND METER AND THE MOTORCYCLE**

- The sound levels will be measured with the sound meter/microphone fixed on a tripod, in the horizontal position, at the rear of the motorcycle.
- For the place and position of the motorcycle, ensure that there are no solid obstacles within 10 meters around the microphone.
- The sound meter will be positioned at a distance of 2 metres behind the motorcycle, at an angle of 45° from the centerline, on the exhaust side and at a height of 1.35 metre above the ground. The sound meter must be level and horizontal.
- The 2 metre distance is measured from the point where the centre of rear tyre touches the ground.
- It is preferred to make the tests on soft ground, not reverberating, i.e. grass or fine gravel.
- In other than moderate wind, machines should face forward in the wind direction.
- The ambient sound level must remain lower than 100 dB/A.

## **THE POSITIONING OF THE MOTORCYCLE (see illustrations following)**

### **The reference points:**

- For a motorcycle: the contact point of the rear wheel on the ground.
- For motorcycles fitted with 2 exhaust outputs, the measurement will be made on the side of the air intake. If a central positioned air intake is used, both sides will be tested.
- For Side-cars: the contact point of the side wheel on the ground.
- For Quad vehicles: the vertical line to the ground from the centre point of the rear axle.
- For Quad vehicles with exhaust outlet moved from the median axis, the measurement will be made on the offset side.

To make repetitive measurements, all motorcycles can be positioned into a small frame fixed on the ground.

## **THE NEW 2 METRE MAX METHOD – THE OPERATION – PROTECT YOUR HEARING – USE EAR PROTECTION**

- The measurement is made with motorcycle on its wheels, with a hot engine.
- The technical steward takes place besides the motorcycles, opposite to the microphone, not to screen or stand between the bike and the microphone. **A mechanic, placed on the left side of the motorcycle, shall disengage the clutch.**
- If a second steward is permanently attending the sound level checks, it is strongly advised for him to use earplugs, a headset or ear protectors.
- The Inspector shall open throttle as fast as possible until full open throttle (instantly, within 0.3 seconds). He will keep the engine at max engine 'rpm' for at least 1 second. To conclude, the inspector will release the throttle quickly.
- If the result exceeds the limit, including 'after fire', the Inspector shall test the motorcycle a maximum of two more times.
- For motorcycles equipped with an engine rpm limiter, the throttle will be opened - instantly, within 0.3 seconds - and kept open until at least 1 second has passed and/or until there is an audible sign that the engine is over-revving.
- For motorcycles without an engine 'rpm' limiter, the throttle will have to be opened for less than 2 seconds and/or until there is an audible sign of over-revving the engine.
- If the engine starts to misfire close the throttle slightly and re-open the throttle.
- If detonations appear, the measurement must be started again.

The numbers obtained from the test shall not be rounded down.

For the sound level measurement, only the Inspector shall handle the throttle. He shall open the throttle himself in order to minimize any influence by another operator (it is helpful to have the microphone equipped with an extension cable to the sound meter).

***! INSERT HERE: The 2 metre max test 'timing' illustration (pdf)***

## **THE MEASUREMENT – RECORDING OF THE SOUND LEVEL**

- When the measurement is considered acceptable, write down the result, then reset (push on the sideline) the MAX MIN setting until the previously displayed value disappears.
- Push again on the MAX MIN sideline to arm the sound level meter.
- The sound level meter is then ready for the following measurement.

Any attempt by a participant to prevent his/her engine from reaching the maximum published rpm figure will be considered a breach of the rules.

Even after a motorcycle has passed the sound control, if there is any doubt, it may be checked again.

A noticeably lower engine speed is detected easily by hearing. In case of doubt, check the value of the rpm limiter with a tachometer.

Sound levels will be checked against the limits stated in the section pertaining to the relevant discipline.

For the initial sound control and technical inspection, a rider (or his mechanic) shall present only one spare silencer per machine.

Other spare silencers may be presented after all participants have presented their motorcycles, or on the following days of the event.

### **79.03            Sound control during and after the competition**

In a competition which requires a final examination of machines before the results are announced, this examination must include a sound control measurement of at least three machines chosen at the discretion of the Clerk of the Course in co-operation with the Chief Technical Steward.

### **79.07**

The sound level for engines with more than one cylinder will be measured on each exhaust end.

### **79.08**

A machine which does not comply with the sound limits can be presented several times.

### **79.09**

When presented for examination, the correct stroke must be stamped in a clearly visible position on the crankcase.

### **79.11            Sound limits in force**

All motorcycles with 250cc and 500cc single cylinder engines  
 All other machines  
 Motoball:

**Use only approved** silencers tested with the '2 metre max' must be used.  
 115 dB/A, measured with the '2 metre max method'.  
 115 dB/A, measured with the 2 metre max method.

**1) Until 31.12.2014 - The maximum sound levels limits are :**

<b>TRACK RACING</b>	<b>Limit</b>	<b>Limit / 2 metre max method</b>
- All categories, all engine types	117dB/A max.	115 dB/A + 2 dB/A For the precision of the method.
- Categories using <b>FIM approved</b> silencers:	117 dB/A	115 dB/A + 2 dB/A For the precision of the method).

**2) From 01.01.2015 - The maximum target value for all silencers tested on machines during/after events will be 112 dB/A (+ 3 dB/A for the precision of the method). This includes all types of exhaust pipes.**

<b>TRACK RACING</b>	<b>Limit</b>	<b>Limit / 2 metre max method</b>
<b>All categories, all engine types</b>	<b>115 dB/A max.</b>	<b>112 + 3 dB/A, for the precision of the method*.</b>  *Following the present system using <b>FIM approved silencers, tested <u>during or after</u> the event.</b>

**79.16 Sound level control after the competition**

In a competition which requires a final examination of machines before the results are announced, this examination must include a sound level control measurement of at least the first three machines listed in the final classification. **See Art. 80.03.**

**FIM approved** silencers made according to Art. 31.07.4 may be controlled for sound in case of doubt.

**79.17 Sound level control during the competition**

In a competition which requires sound level control tests during the event, machines must comply with the sound limits without the tolerance in Art. 79.16.

**01.80 RULES AND GUIDELINES FOR USE OF SOUND LEVEL METERS**

**80.01**

The Sound Control Officer (SCO) must arrive in sufficient time for discussions with the Clerk of the Course and other Technical Officials in order that a suitable test site and testing policy can be agreed.

## 80.02

Sound level measuring equipment must include a compatible calibrator, which must be used immediately before testing begins and always just prior to a re-test if a disciplinary sanction may be imposed.

Two sets of equipment must be available in case of failure of tachometer, sound level meter or calibrator during technical control.

## 80.03 Corrections

Corrections are presented as the 'precision of the method' (table below). All corrections are cumulative.

Track Racing	Limit	2 metre max method
All categories, all engine types	117 dB/A	Objectif : 115 dB/A Following the present system using FIM approved silencers or 115 dB/A + 2 dB/A for the precision of the method.

## 80.04 Ambient temperature

No deductions.

80.05 Action and decisions will depend on the Sporting Discipline concerned, and decisions taken during prior discussions with the FIM Technical Director and/or the Chief Technical Steward.

## 01.81 TIMEKEEPING

Since 1.1.1993, responsibility for Timekeeping has been with referred to the Sporting Commission.

### 81.01 Timekeeping Instruments

All motorcycles (in CMS, CEN and in CTR and CCP where applicable) must have a correctly positioned transponder support. The transponder must be supplied or approved by the official Timekeeper and fixed to the motorcycle (for off-road models, typically on the front fork), on either the left or right side, avoiding being shielded by carbon pieces.

Correct attachment of the transponder bracket consists of a minimum of tie-wraps, but preferably by screws or rivets. Any transponder retaining clip must also be secured by a tie-wrap. Velcro or adhesives alone will not be accepted.

## **01.82 TECHNICAL SPECIFICATIONS FOR MOTOBALL MOTORCYCLES (Diagram I)**

### **82.01 Weight**

70 kg min. and 120 kg max.

### **82.02 Length**

Maximum: 2'200 mm.

### **82.03 Handlebars**

The length of the handlebars is 700 mm maximum. Clip-on handlebars are forbidden. They must not be fitted with the extremities facing forward.

Handlebar ends must be rubber plugged.

Brake and clutch levers must be recessed 20 mm from the handlebar extremity and must be fitted with 20 mm rubber spheres at their extremities.

### **82.04 Seat**

Seat Height is 750 mm minimum and 900 mm maximum.

### **82.05 Suspension**

Front forks: The travel is 80 mm minimum and 100 mm maximum.

Rear suspension: 30 mm minimum and 50 mm maximum.

### **82.06 Chain guards**

A chain guard must be installed to protect the drive chain at the countershaft sprocket and at the rear sprocket.

### **82.07 Mudguard**

If the front wheel is protected by a mudguard, it must not be more than 100 mm between the wheel and the mudguard.

The rear mudguard must not extend beyond the vertical line drawn at a tangent to the rear edge of the rear tyre.

### **82.08 Wheels**

The front and rear wheels must be between 16" and 19" rim diameter. Front tyres are optional. Trial or Speedway tyres must be used for the rear wheel.

### **82.09 Engine**

Motoball motorcycle engines must not exceed 250 cc - 2 or 4-stroke.

The engine must be equipped with a silencer. The number of decibels must not exceed the limit specified in Art. 79.

When losing a silencer the motorcycle must immediately leave the field.

#### **82.10 Brakes**

The motorcycles must be equipped with front brake operated by cable and handlebar lever. The rear brake must be operated by 2 pedals (1 right pedal and 1 left pedal).

#### **82.11 Ball drive (see diagram Ia - Ib)**

Motorcycles must be equipped with a ball drive to avoid the ball being embedded between the front wheel and the engine. The ball drive, fitted to the frame, must be roughly 100 mm away from the mudguard, or the front wheel.

The ball drive also serves as an engine protection in order that no parts (footrests, brake pedals, start lever etc.) go beyond it. A second system of ball drive is allowed, called mechanical system for arcs (see drawings 1 a, and alternative 1 b).

Front extremity ball drive ground clearance must be 140 to 150 mm and side ground clearance must be 170 to 180 mm.

#### **82.12 Throttle controls**

Throttle controls must be self closing in order that the machine slows down or stops in case of a fall.

#### **82.13 Stands**

The rear stand or side stand or any mechanical addition which could drive the ball without using the foot is forbidden.

### **01.83 ADDITIONAL RULES FOR 80 CC SPEEDWAY MOTORCYCLES**

In general, machines must comply with the technical requirements for Track Racing. In case of conflict, these rules have priority.

Providing a motorcycle confirms to the requirements of the FIM Track Racing regulations, as well as to a number of specific conditions that the FIM may require, no restriction is placed on the make, construction or type of motorcycle used.

#### **83.01 Classes**

Motorcycles may be equipped only with a standard, mass produced, 2-stroke, single cylinder engine, available to the public through the normal commercial sales channels of the original engine manufacturer.

The cylinder capacity may be over 50 cc and up to 85 cc, as originally produced by the manufacturer.

### **83.01.1 Minimum weights: 55 kg**

### **83.02 Fuel, Oils and Coolants**

All motorcycles for 80 cc Speedway must function on unleaded petrol with a maximum lead content of 0.005 g/l and a maximum MON of 90 (see also Art. 01.63 for full specifications).

Water-cooled engines must use a closed circuit cooling system. Coolant may be carried in the frame.

The use of octane boosters is forbidden.

For environmental reasons, the rider/team/mechanic must at all times place a receptive container under the motorcycle to catch waste oil and coolants, etc., when working in the pit-area during an event.

### **83.03 Machine specifications**

#### **83.03.1 Engine**

Any 'defect' or 'broken' parts may only be replaced by an 'original spare part', available and sold through the network of dealerships of the manufacturer in question.

#### **83.03.2 Carburation Instruments**

The originally fitted carburettor must be used. The only modifications permitted are jetting changes.

#### **83.03.3 Exhaust pipe, silencer**

The exhaust pipe and silencer must be fixed in a proper way and fastened on the motorcycle in a minimum of 3 different places.

Max. sound level: 98 db/A at 8000 rpm.

### **83.04 Frame**

#### **83.04.1 Specifications**

The maximum wheelbase is 1325 mm.

The use of titanium and composite materials is completely forbidden in the construction of the frame **and swing-arm**.

#### **83.04.2 Brakes**



Brakes are not permitted.

### **83.04.3 Wheel, Rim & Tyre Sizes**

Front wheel rim size:	max. 3.00 (the diameter is free)
Front wheel tyre, max. width:	no restriction
Front tyre tread:	free
Rear wheel rim size:	max 1.85" x 17"
Rear wheel tyre size:	max. 3.00" x 17"
Rear tyre tread:	must be of the type with 'trial' or 'track' tread.

### **83.04.4 Handlebars**

Handlebars width: minimum 650 mm, maximum 850 mm.

### **83.04.5 Footrests**

Refer to Art. 01.39.

## **01.84 TECHNICAL SPECIFICATIONS FOR 125 CC GRASS TRACK MOTORCYCLES**

In general, machines must comply with the technical requirements for Track Racing. In case of conflict, these rules have priority.

Providing a motorcycle confirms to the requirements of the FIM Track Racing regulations, as well as to a number of specific conditions that the FIM may require, no restriction is placed on the make, construction or type of motorcycle used.

### **84.01 Classes**

Motorcycles must be equipped with a single cylinder, 4-stroke engine, with a capacity between 100cc and 125cc (with the maximum limit of 129cc, to allow repairs)

#### **84.01.1 Minimum weights: 60 kg**

### **84.02 Fuel, Oil and Coolants**

All engines must function on pure methanol or unleaded petrol with a maximum lead content of 0.005 g/l and a maximum MON of 90 (see also Art. 01.63 for full specifications).

The use of octane boosters is forbidden.

Water-cooled engines must use a closed circuit cooling system. Coolant may be carried in the frame.

For environmental reasons, the rider/team/mechanic must at all times place a receptive container under the motorcycle to catch waste oil and coolants, etc. when working in the pit- area during an event.

## **84.03 Machine specifications**

### **84.03.1 Engine**

Any 'defect' or 'broken' parts may only be replaced by an 'original spare part', available and sold through the manufacturers' dealership network.

### **84.03.2 Carburation Instruments**

Maximum diameter: 29 mm. This measurement must be taken on the engine side from the slide/throttle valve edge.

Fuel injection systems are forbidden.

### **84.03.3 Exhaust pipe, silencer**

The exhaust pipe and silencer must be fixed in a proper way and fastened on the motorcycle in a minimum of 3 different places.

Max. sound level: 98 db/A at 8000 rpm.

## **84.04 Frame**

### **84.04.1 Specifications**

The use of titanium and composite materials is completely forbidden in the construction of a frame.

The frame must be equipped with front and rear suspension.

Purpose-built speedway and grass-track frames may be used (grass-track frames have rear suspension).

### **84.04.02 Brakes**

Brakes are not permitted.

## **84.05 Wheels, Rims, Tyres**

Front min 1" more than the size of the rear mounted wheel.

Rear min 17" – max 22"

Maximum tyre width of the rear wheel: 100 mm

Only tyres which conform to the Track Racing profile (trials universal type pattern/ track tread) can be used.

#### **84.06 Handlebars**

Handlebars width: minimum 650 mm, maximum 850 mm.

#### **84.07 Footrest**

Refer to Art. 01.39.

### **01.85 TECHNICAL SPECIFICATIONS FOR FLAT TRACK MOTORCYCLES**

#### **85.01 General**

The concept for the Technical rules for Flat Track motorcycles is taken from the technical specifications for Motocross/Enduro/Suppermoto motorcycles.

Titanium can be used, except for the frame, **the swing-arm** and wheel spindles.

For all these classes the Technical Regulations for Track Racing shall apply with the addition of the following rules:

#### **85.02 Capacity**

The following engine capacities are allowed on the FIM Flat Track Rounds:

- Two Strokes: over 250cc up to 500cc, single cylinder engines
- Four Strokes: over 250cc up to 750cc, single cylinder engines
- Up to 1200cc: two cylinder engines

#### **85.03 Specifications**

Subject to implementation of the compulsory requirements of these regulations, adjustments, modifications/changes may be made to the frame and the appearance of the machine.

#### **85.04 Suspension fork**

The front fork stanchion tubes must not protrude more than 5 cm above the upper triple clamps.

#### **85.05 Brakes**

Front wheel brakes are only permitted for TT Meetings.

In all other Flat Track Classes of competition front brakes are prohibited and all components relating to the front brake must be removed.

The rear wheel must have an efficient brake system.

#### **85.06 Wheels and Tyres**

The front and rear wheel diameters are: **minimum. 16 inches, maximum 19 inches.**

**The original (moulded) tyre tread pattern cannot be cut or modified. Handcut tyres are not permitted. The depth of tread: minimum of 2 mm, maximum 8 mm.**

**MX-, Trial-, Enduro- and/or Track Racing type tyres are not permitted.**

#### **85.07 Number plates and riders' bibs**

Number plates are required as follows:

- One front number plate, mounted on the top section of the front forks and a bib on the back of the rider
- Two number plates, one mounted on each side of the motorcycle behind the rider
- Number plate dimensions are : 25 cm x 30 cm (height x length)
- Colours : black numbers on a yellow background
- The minimum dimensions of the figures are: 20 cm x 12 cm, and a minimum of 30 mm stroke.

#### **85.08 Fuel**

All motorcycles must be fuelled with unleaded petrol (see Art. 01.63, 63.01); the use of methanol or any other additive is strictly forbidden.

#### **85.09 Oils and coolants:**

- Oil: see Art. 63.02
- Coolants: The only liquid engine coolants permitted other than lubricating oil shall be water or water mixed with ethyl alcohol.

#### **85.10 Carburation systems**

Any fuel injection system or carburetion is permitted.

Only engine control units (ECU, Kit ECU) which are supplied by the manufacturer of the engine are allowed. Wiring harness, spark plugs, plug wires and spark plug caps may be replaced.

#### **85.11 Footrests**

Footrests must comply with all of the following:

- a) Fixed to the original mounting position on the frame provided by the manufacturer
- b) Not lower than the frame or the lowest part of the engine
- c) No 'Speedway' or 'Long Track' type footrest is allowed

#### **85.12 Engine and Throttle Controls**

An engine stop switch (connected through a lanyard to the riders' wrist) must be fitted to the ignition system of the machine. See. Art. 01.37.

### **85.13 Noise Level and Exhaust pipe(s)**

The noise level of any machine must meet the current FIM requirements for Track Racing motorcycles: maximum 115 db/A (measured by the 2 metre max method).

### **85.14 Minimum height**

In a complete upright position without a rider, the ground clearance from the lowest part of the frame or the engine (excluding the exhaust pipe and silencer) to the ground shall not be lower than:

- 20 cm for the 'TT', 'Short Track' and the 'Half Mile' races;
- 18 cm for the 'Mile' races :

### **85.15 Gear Box**

The gear box itself must be fully integrated with the engine.

A separate gear box (similar to that used in Long Track or Ice Racing disciplines) is not permitted.

### **85.16 Helmets**

The helmets must comply with the FIM General Technical Rules – **see Art. 01.67**.

### **85.17 Technical Verifications**

Prior to any practice or racing all motorcycles will be checked to ensure the compliance with the technical rules.

All motorcycles entered in the event must comply with these regulations and the Supplementary Regulations, whether the intention is to use the motorcycle or not.

Any rider not complying with the regulations will be disqualified from the race and his motorcycles removed from the pits.

### **85.18 FIM Logo**

The FIM stickers/logos must be fitted on the top of the 3 number plates (see diagram). The stickers/logos will be provided by FIM and/or the organiser.

INSERT DIAGRAMS

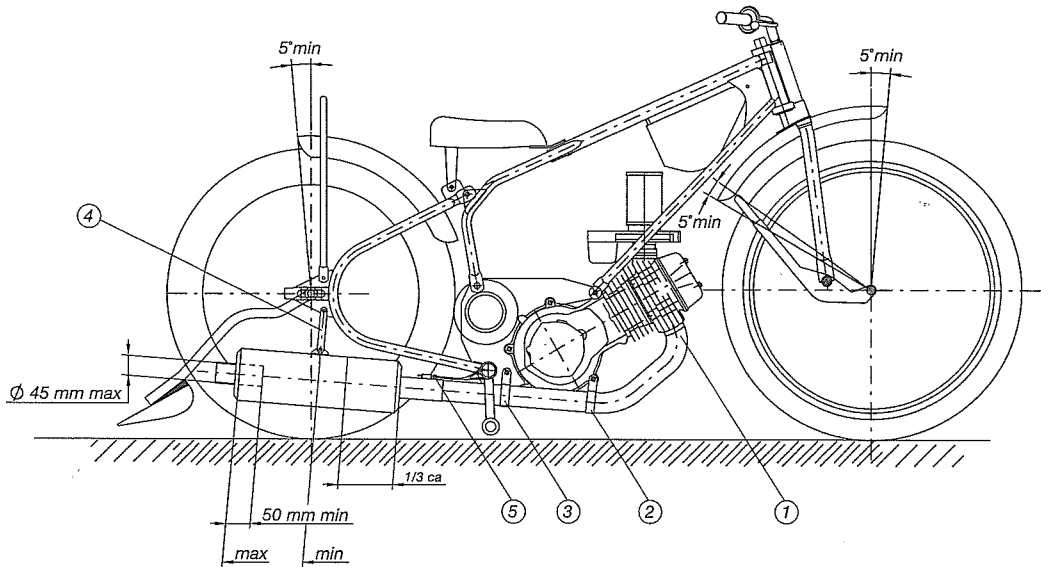

FOOTRESTS  
REPOSE-PIED

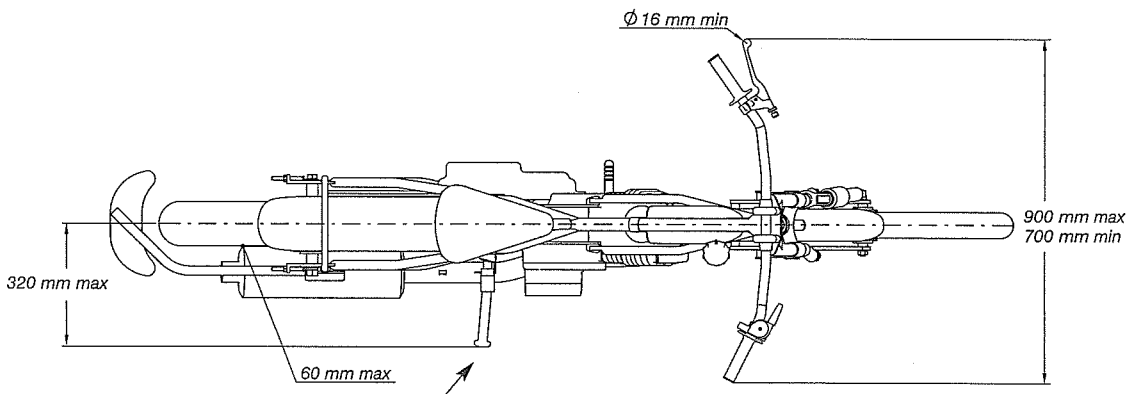
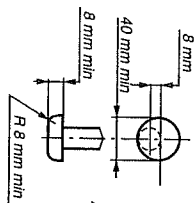

CHAIN GUARD  
GARDE-CHAÎNE

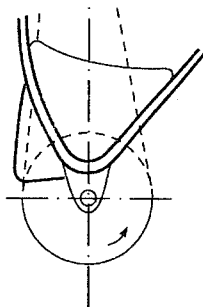

OPEN TRANSMISSION GUARDS  
GARDE-CHAÎNE OUVERTE

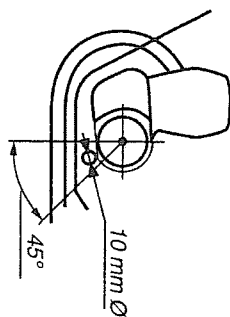

CARBURETTOR SECTION  
PLAN CARBURATEUR

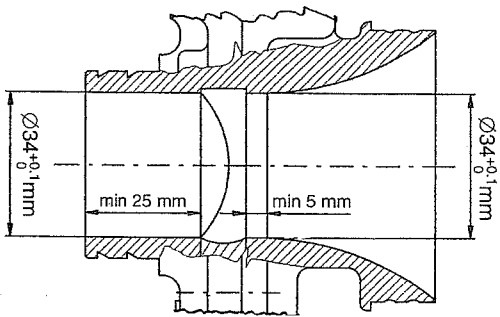
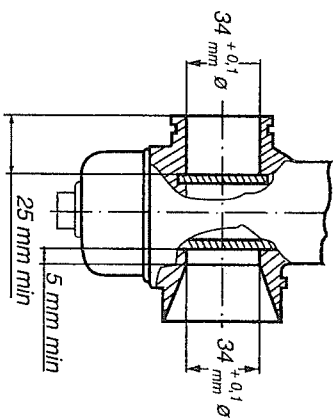

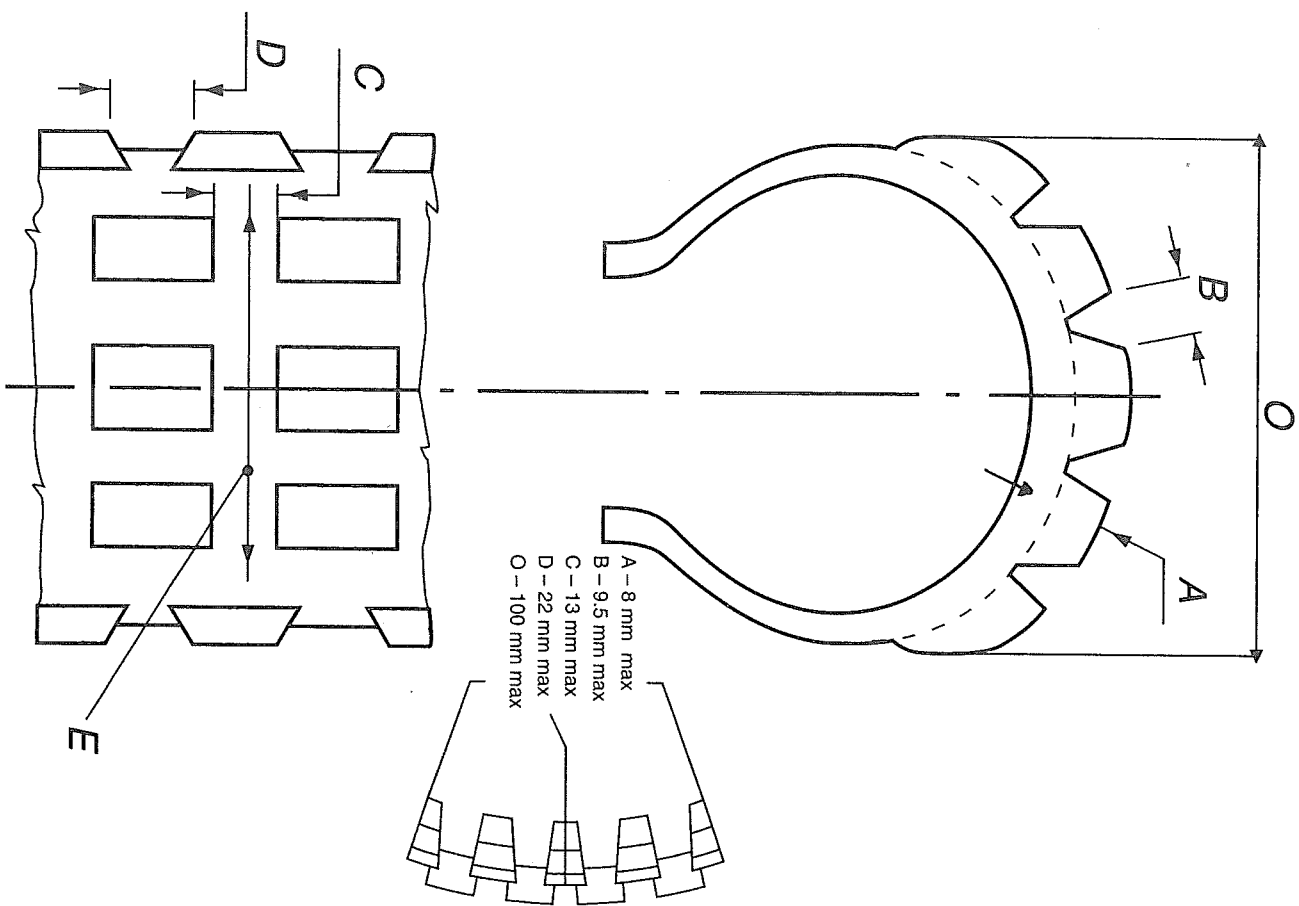

MOTOBALL

1a

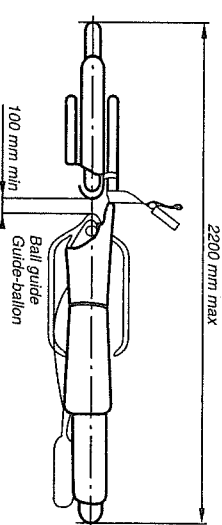
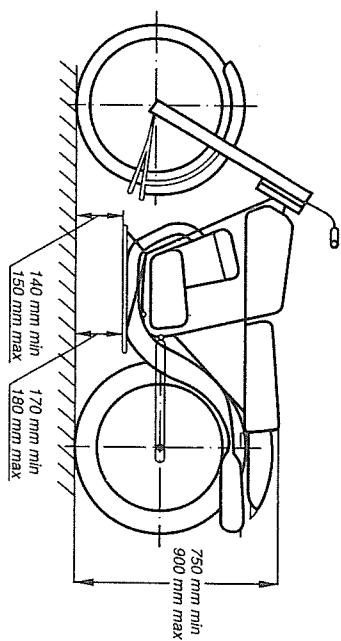

1b

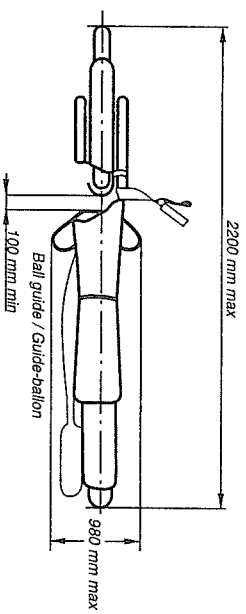
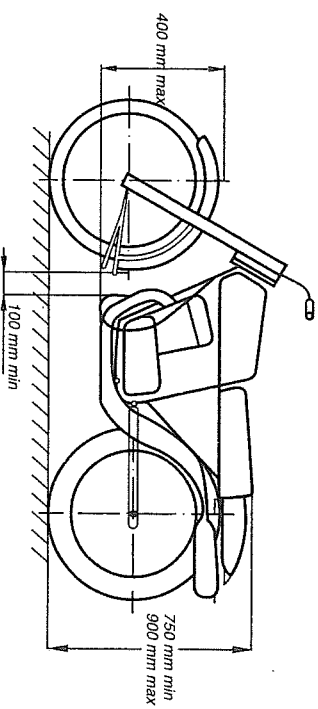

**ICE / GLACE**

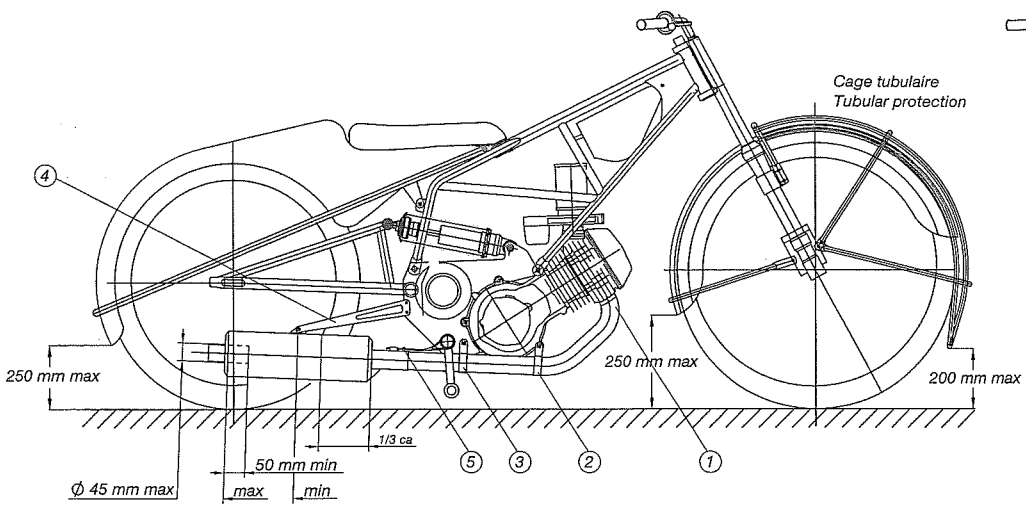
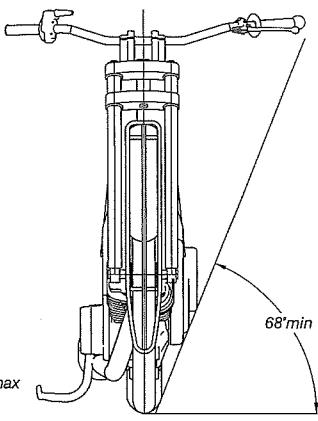

**H**

**FOOTRESTS  
REPOSE-PIED**

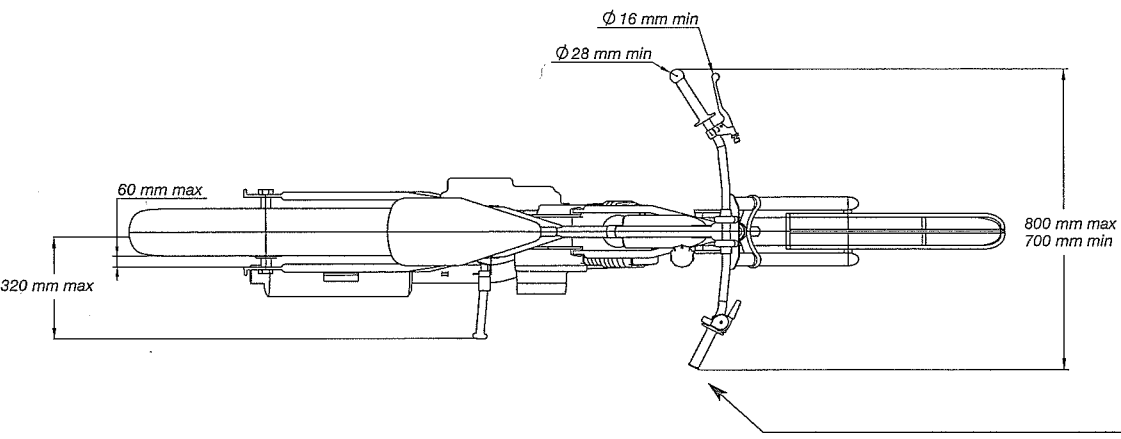
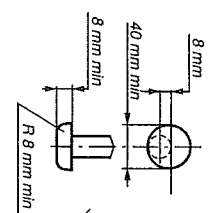

**ICE / GLACE**

**CARBURETTOR SECTION  
PLAN CARBURATEUR**

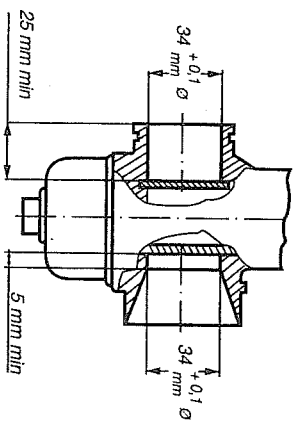

**H**

**CLEARANCE**

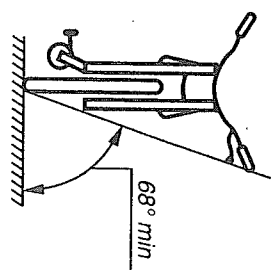

**OPEN TRANSMISSION GUARDS**

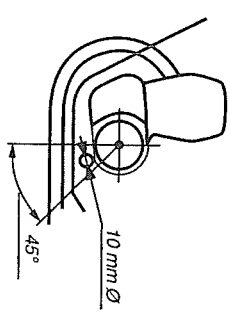

**REAR WHEEL  
PROTECTION  
ROUE ARRIERE**

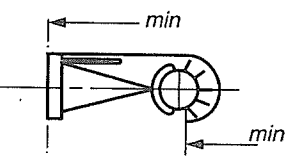

**ICE SPEEDWAY SPIKES**

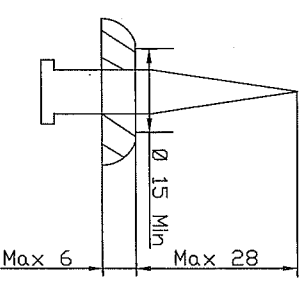

**NEW ICE SPIKES DRW**

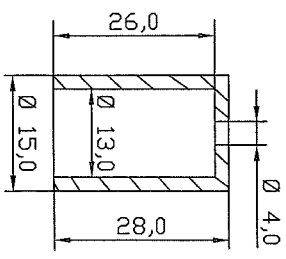

**SPIKE GAUGE**



LONG / LONGUE

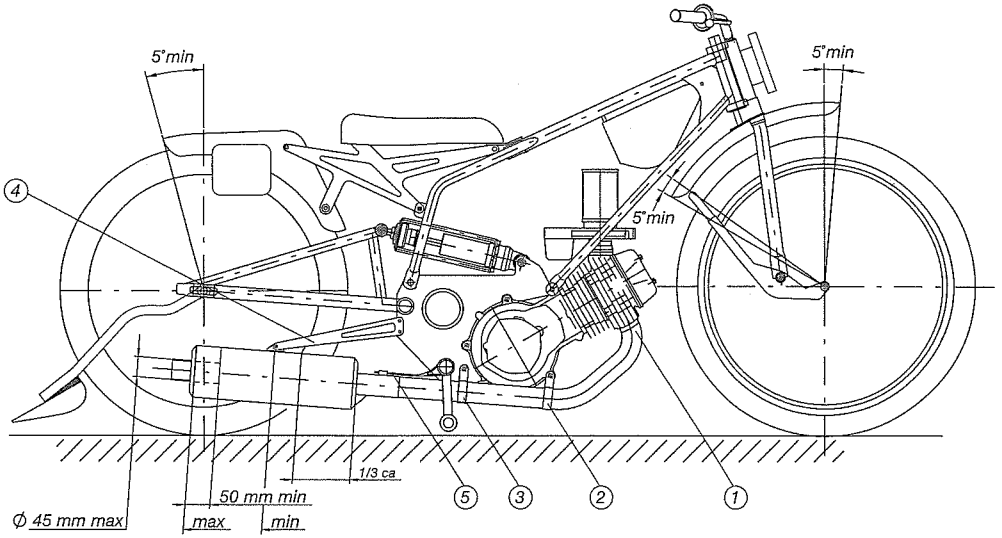

K

FOOTRESTS  
REPOSE-PIED

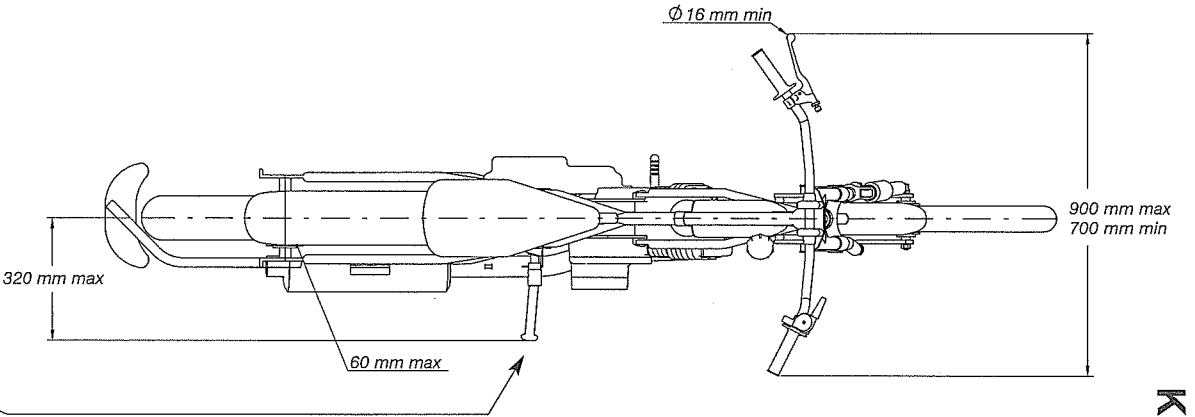
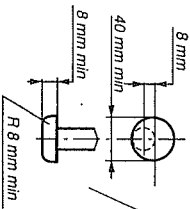

LONG / LONGUE

OPEN TRANSMISSION GUARDS  
GARDE-CHAÎNE OUVERTE

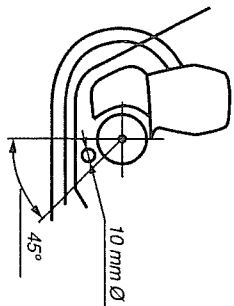

CHAIN GUARD  
GARDE-CHAÎNE

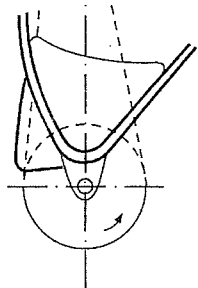

CARBURETTOR SECTION  
PLAN CARBURATEUR

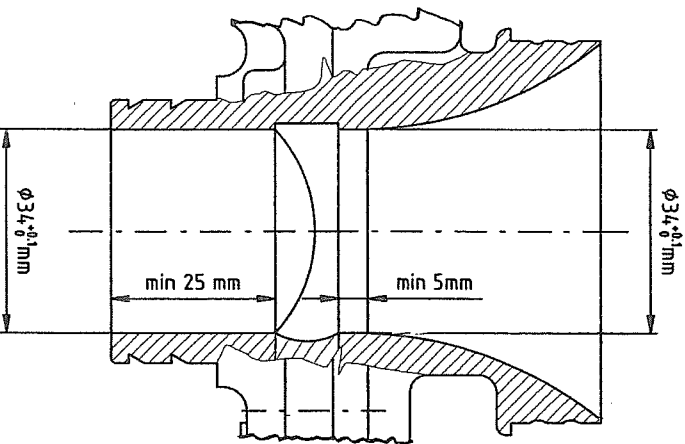

CARBURETTOR SECTION  
PLAN CARBURATEUR

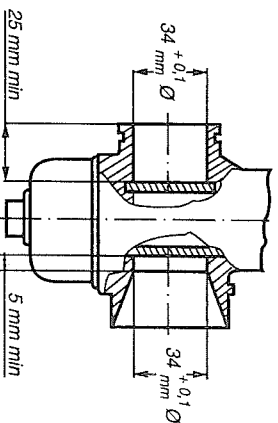

# TRACK / PISTE SIDECAR

L

(voir / see art. 01.53)

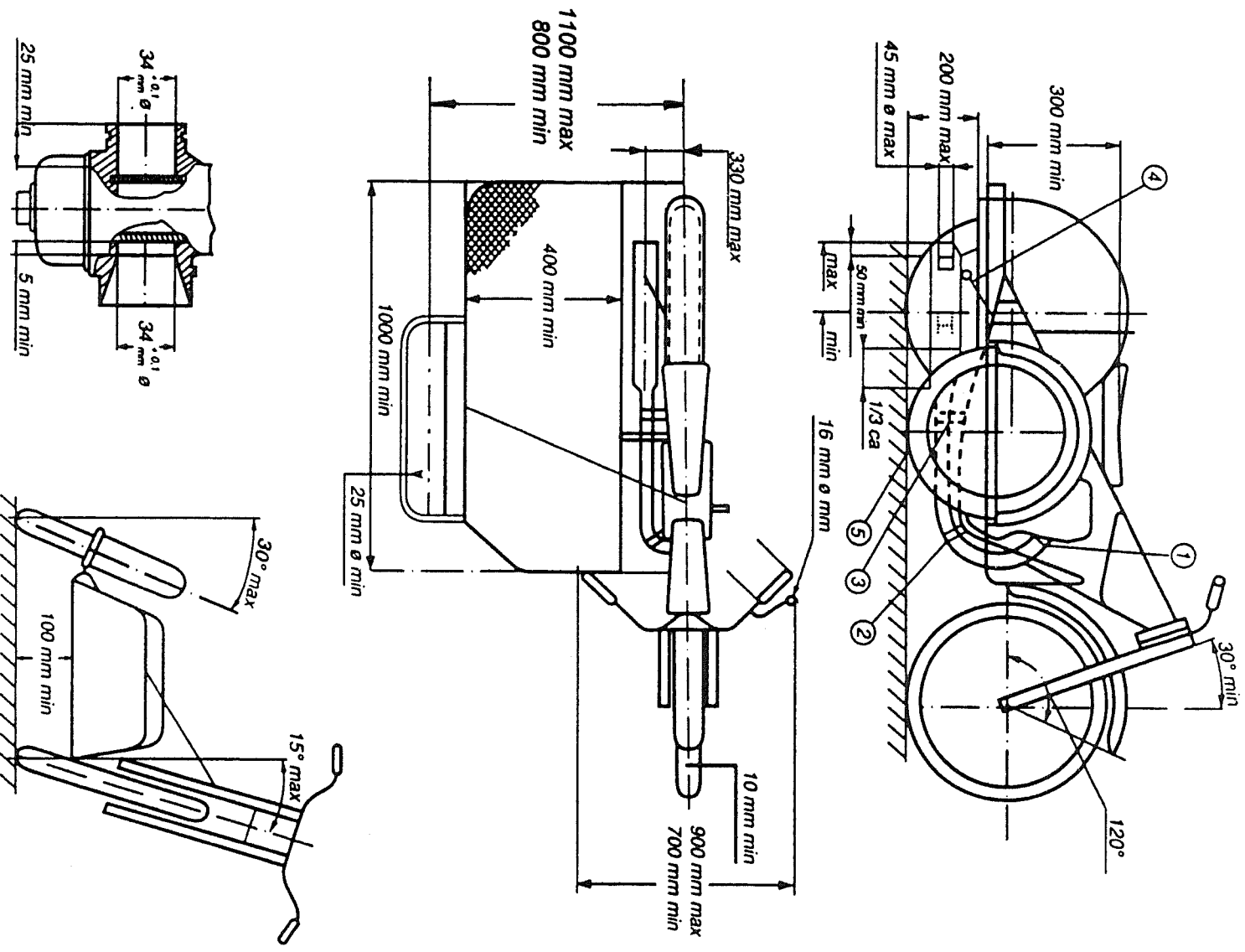

**DIRT DEFLECTOR /  
DEFLECTEUR ANTI-PROJECTION  
ART. 58.03**

**S**

**ART. 01.31**

**P**

TERE TO DEFLECTOR CLEARANCE / INSTALLATION ANGLE  
ESPACE ENTRE LE PNEU ET LE DEFLECTEUR / ANGLE DE MONTAGE

Dirf deflector  
FIM article 58.03

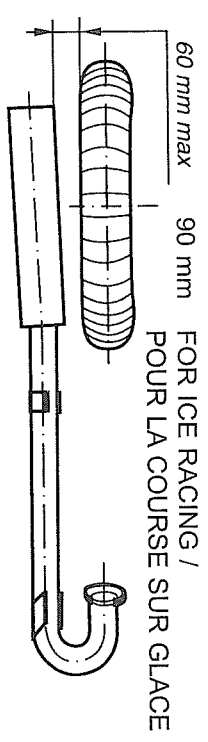
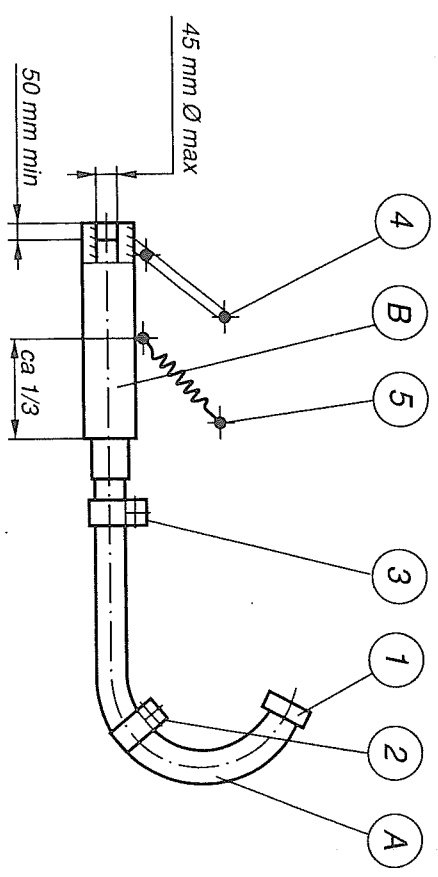
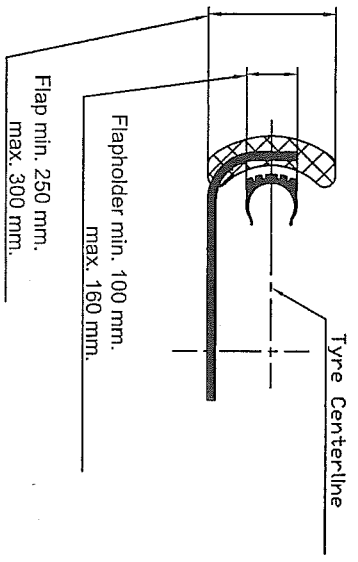
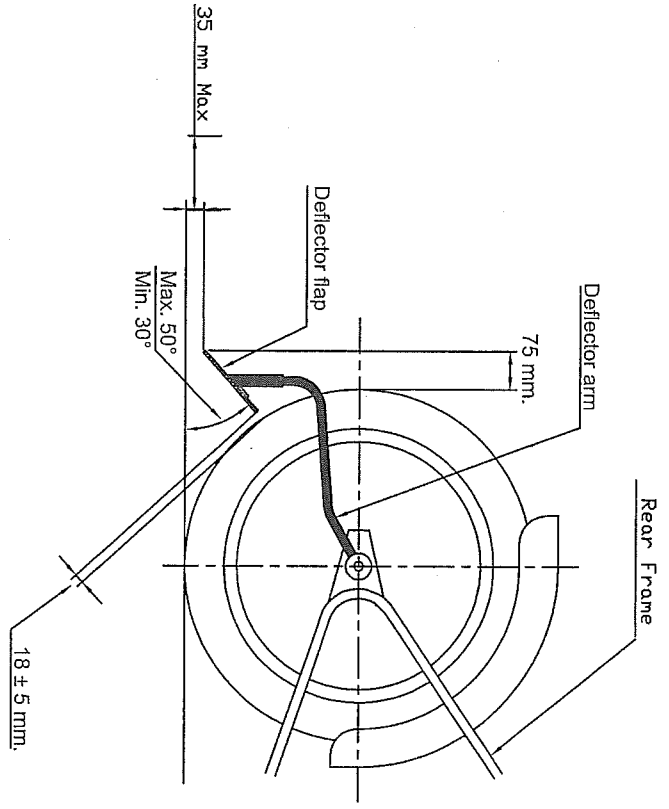

A = Exhaust Pipe (tuyau d'échappement)  
B = Silencer (silencieux)

FOR ICE RACING /  
POUR LA COURSE SUR GLACE

## TEN FITTING TESTS FOR HELMETS DIX TESTS D'ADAPTATION POUR LES CASQUES

1. *Obtain correct size by measuring the crown of the head*  
Avoir la bonne grandeur en mesurant le sommet de la tête
2. *Check there is no side to side movement*  
Vérifier qu'il n'y ait pas de déplacement d'un côté à l'autre
3. *Tighten strap securely*  
Serrer solidement la jugulaire
4. *With head forward, attempt to pull up back of helmet to ensure helmet cannot be removed this way*  
Tête en avant, essayer de soulever le casque pour s'assurer qu'il ne peut pas être enlevé de cette façon
5. *Check ability to see clearly over shoulder*  
Vérifier si vous pouvez voir clairement par-dessus l'épaule
6. *Make sure nothing impedes your breathing in the helmet and never cover your nose or mouth*  
S'assurer que rien ne gêne votre respiration dans le casque et ne jamais couvrir le nez ou la bouche
7. *Never wind scarf around neck so that air is stopped from entering the helmet. Never wear scarf under the retention strap*  
Ne jamais enrouler une écharpe autour du cou, car cela empêche l'air d'entrer dans le casque. Ne jamais porter d'écharpe sous la jugulaire
8. *Ensure that visor can be opened with one gloved hand*  
S'assurer que la visière peut être ouverte avec une main gantée
9. *Satisfy yourself that the back of your helmet is designed to protect your neck*  
S'assurer que l'arrière de votre casque a une forme telle qu'il vous protège la nuque
10. *Always buy the best you can afford*  
Toujours acheter le meilleur que vous pouvez vous offrir



## INTERNATIONAL HELMETS STANDARDS NORMES INTERNATIONALES DES CASQUES

ECE 22 - 05 "pi" (EUROPE)

The ECE mark consists of a circle surrounding the letter E followed by the distinguishing number of the country which has granted approval

**E1** for Germany, **E2** for France, **E3** for Italy, **E4** for Netherlands, **E5** for Sweden, **E6** for Belgium, **E7** for Hungary, **E8** for Czech Republic, **E9** for Spain, **E10** for Yugoslavia, **E11** for UK, **E12** for Austria, **E13** for Luxembourg, **E14** for Switzerland, **E15** (- vacant), **E16** for Norway, **E17** for Portugal, **E18** for Denmark, **E19** for Roumania, **E20** for Poland, **E21** for Portugal, **E22** for the Russian Federation, **E23** for Greece, **E24** for Ireland, **E25** for Croatia, **E26** for Slovenia, **E27** for Slovakia, **E28** for Bielo Russia, **E29** for Estonia, **E30** (- vacant), **E31** for Bosnia and Herzegovina, **E32** for Letonia, **E34** for Bulgaria, **E37** for Turkey, **E40** for Macedonia, **E43** for Japan, **E44** (- vacant), **E45** for Australia, **E46** for Ukraine, **E47** for South Africa, **E48** New Zealand.

Below the letter E, the approval number should always begin with 05. Below the approval number is the serial production number. (Label on retention system or comfort interior).



(JAPAN) JIS T 8133 : 2007  
(Label affixed inside the helmet).



(USA) SNELL M2010  
(Label affixed inside the helmet).

For more details consult the F.I.M. Technical Rulebook

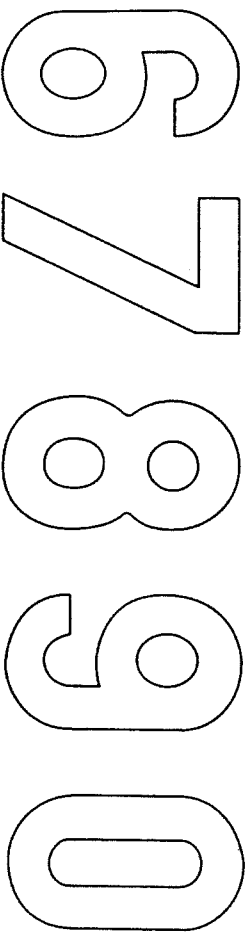
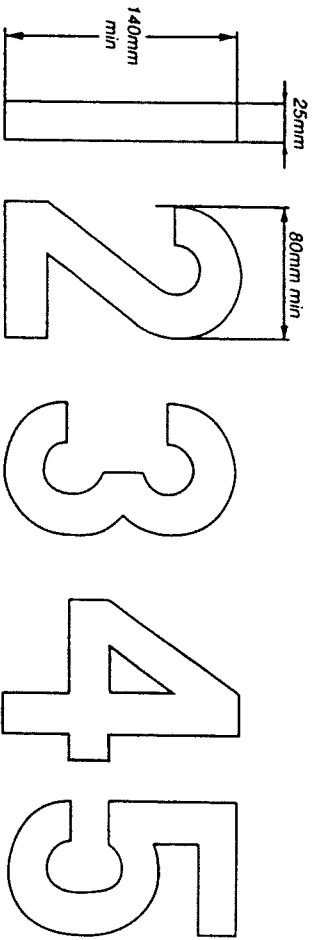
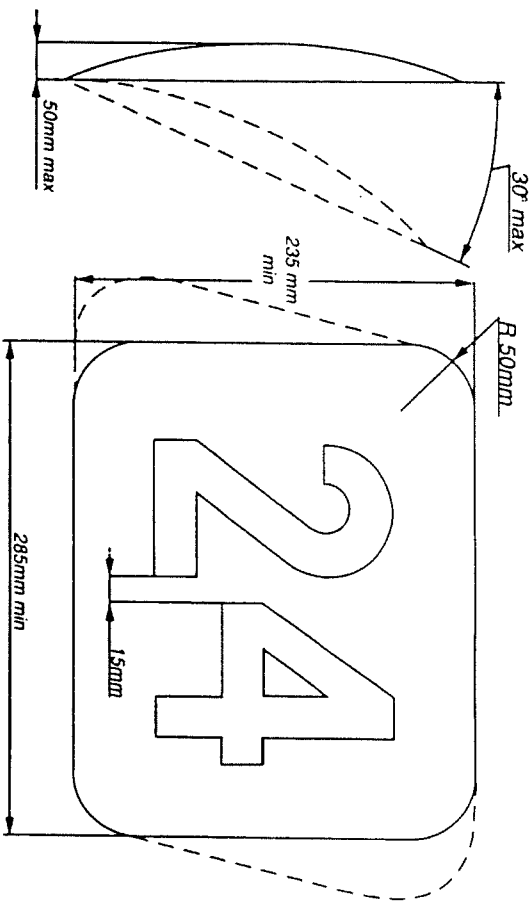

Futura Heavy

0123456789

Futura Heavy Italic

0123456789

Univers Bold

0123456789

Univers Bold Italic

0123456789

Oliver Med.

0123456789

Oliver Med. Italic

0123456789

Franklin Gothic

0123456789

Franklin Gothic Italic

0123456789