

TABLE OF CONTENTS

Sr. No.	Description	Page No
0	Executive Summary	1
0.1	Introduction	1
0.2	Topographic and Hydrographic Surveys	2
0.3	Hydrology and Sedimentation	3
0.4	Geological and Geotechnical Investigations and Seismic Hazard Assessment.....	5
0.5	Site Selection (Project Layout Studies).....	7
0.6	Project Sizing	8
0.7	Civil Engineering Studies	8
0.7.1	Diversion Structure:.....	9
0.7.2	Spillways	9
0.7.3	Low Level Flushing Outlets	9
0.7.4	River Diversion Works.....	10
0.7.5	Power Intakes	10
0.7.6	Desander Chambers	10
0.7.7	Power Waterways	11
0.7.8	Surge Chamber	11
0.7.9	Penstocks.....	11
0.7.10	Power House Complex.....	11
0.8	Hydro-Mechanical Studies	12
0.8.1	Turbines and Ancillaries.....	12
0.8.2	Spillway and Low Level Outlets.....	12
0.8.3	Power Intakes	12
0.8.4	Desander Basins.....	13
0.8.5	Powerhouse Equipment	13
0.9	Electrical Engineering Studies.....	13
0.9.1	Electrical Equipment.....	13
0.9.2	Generator	14
0.9.3	Isolated Phase Bus Duct (IPB).....	14
0.9.4	11 / 132 / $\sqrt{3}$ kV Step-up Transformers	14
0.9.5	132 kV High Voltage Cables	15
0.9.6	Protection Equipment.....	15
0.9.7	Station AC Auxiliary Supply.....	15
0.9.8	110 V DC Supply.....	15
0.9.9	Plant Control System.....	15
0.10	Power and Energy Potential.....	16
0.11	Power System and Transmission Studies.....	17

**Shogo-Sin Hydropower Project
Feasibility Study Report
Executive Summary**

Sr. No.	Description	Page No
0.11.1	Power System Study	17
0.11.2	Transmission Study	17
0.11.3	Load Flow Study	17
0.11.4	Short Circuit Study	18
0.11.5	Transient Stability Study	18
0.11.6	Design and Engineering of Proposed Interconnection Scheme	19
0.12	Socio-Economic and Environmental Studies	20
0.13	Project Implementation and Construction Planning	21
0.14	Bill of Quantities and Cost Estimates	22
0.15	Economic and Financial Analysis	23
0.16	Conclusions and Recommendations	26
0.16.1	Hydrological Investigations	26
0.16.2	Geotechnical Investigations and Testing	26
0.16.3	Physical Hydraulic Modeling	26
0.17	Project Configuration	27
0.18	Salient Features	30

0 Executive Summary

0.1 Introduction

During the seventies, rapid development in all sectors of the economy led to an abrupt increase in power demand and a serious shortage of energy was experienced throughout Pakistan. According to the Electricity Marketing Handbook (June 2008), published by PEPCO there is a shortage of 3, 648 MW. According to the Daily Dawn Newspaper of 24 December, 2009, this shortage has now increased to 4,200 MW.

The hydropower potential of the Chitral Region had been studied first during 1982-84 by WAPDA and MONENCO of Canada who prepared an inventory and ranking study of potential storage and hydropower generation sites along the upper reaches of the Indus and its main tributaries, Jehlum (above Mangla) Swat and Chitral Rivers. No hydropower scheme was proposed in the Chitral Region. Later, during 1987-1992 and 1999-2000, the Sarhad Hydel Development Organization (SHYDO) and Hydro-electric Planning Organization (HEPO), WAPDA, in collaboration with German Agency for Technical Co-operation (GTZ) , carried out studies in the Azad Jammu and Kashmir (AJK), Northwest Frontier Province (NWFP) and Northern areas to identify hydropower potential and rank schemes. A number of small and medium hydropower schemes including Shogo-Sin and Shushghai-Zendoli were identified.

The Islamic Republic of Pakistan received financing from the Asian Development Bank (ADB) as Technical Assistance (TA) Loan and Technical Assistance Grant for infrastructure and development projects under the Power Sector component of the ADB TA Loan 2178-PAK (SF). Following financing, the Government of Pakistan (GOP) through its Ministry of Power and Water decided to use a portion of the loan to carry out Bankable Feasibility of International Standard for Shogo-Sin Hydropower Project and Shushghai-Zhendoli Hydropower Project under the Private Power and Infrastructure Board (PPIB) as the Executing Agency (EA).

On the basis of International Competitive Bidding (ICB) process, a team of Consultants and Sub-Consultants with Mirza Associates Engineering Services Ltd

(Pakistan) as the lead Consultant were selected for carrying out the feasibility studies for the two projects.

The Client's Notice to Proceed was issued on 14 February, 2009. The completion date of the studies as per the Contract is 14 April, 2010.

0.2 Topographic and Hydrographic Surveys

Topographic survey has been conducted for weir (50 hectares) and powerhouse (30 hectares) area and longitudinal profiles of the Turkho River have been prepared. Lutkho River Valley cross-sections have been observed at weir site, on the upstream and downstream of weir. For Lutkho River, cross-sections have been taken at powerhouse site and on its upstream and downstream. The weir and powerhouse have been located 10 kilometers, North-west of Chitral Town and weir about 23 km from it. For the inaccessible areas of tunnels alignment, topographic maps were developed with the help of high resolution digital elevation models (DEM).

Topographic sheets of survey of Pakistan (SOP) at scales, 1:250,000 and 1:50,000 were used to start with the survey work. Detailed maps of Project Area on 1:1,000 scales with contour interval of two (02) meters have been prepared. The detailed topographic survey has been carried-out with Sokkia Total Stations. All important features falling in the area, like road, tracks, nullahs, rivers, huts, water channels have been picked-up according to their geographical positions. In order to prepare topographic maps at large scale, reference grid has been established by connecting the area to be surveyed with SOP Grid. The coordinates of SOP Bench Mark at Kufu have been used to establish the level and horizontal coordinates for the Project Area. From Kufu, traversing and leveling has been carried-out first to powerhouse site and then to weir area in Turkho Valley.

For conducting the hydrographic survey, geodetic network for topographic survey has been used for linking the river bed cross-sections and connecting nodes. The water depth has been taken by sounding at appropriate distance. Due to small water depth Lutkho River, no special arrangements had to be made in this respect.

0.3 Hydrology and Sedimentation

For the Shogo-Sin Hydropower Project, three stream flow gauging stations were established by the Consultant, one on the upstream of the Shogo-weir site, second on the downstream of the weir site and third on the downstream of the Sin Powerhouse Site. On all three stream gauging stations, staff gauges have been installed where flow measurements are being made on six hourly basis at 06:00 a.m., 12:00 noon and 06:00 p.m.

Discharge measurements were started from 01st May, 2009 at the rate of twice per week in summer season and once per week in winter season. The water and sediment sampling was continued till January, 2010.

.At Chitral Climatological station maximum daily precipitation was observed as 109 mm. Mean maximum monthly precipitation appears in the month of March with a magnitude of 111 mm, whereas, lowest precipitation appears in the month of August. The month of August has also the highest average evaporation and January the lowest i.e. 97 mm and 49 mm, respectively. Average annual evaporation at Chitral stream gauging station is 898 mm. July is the warmest month with temperature of about 27.96 °C and January is the coldest month with the temperature of 4.61°C on mean monthly basis.

The elevation in the watershed varies from 2005 to 7368 m.a.s.l. The average elevation of the Shogo watershed is 4009.5 m.a.s.l. The highest slope in the watershed is 87.5% and lowest 0.1 % with a standard deviation of 13.52% on the basis of 1000 m grid resolution DEM. The average slope of the watershed is 27.07%.

The minimum, average and maximum daily flows at weir site were found as 13.19, 45.30 and 131.79 m³/s, respectively. The minimum, mean and maximum 10-daily flows at the dam site were computed as 13.21, 45.09 and 128.16 m³/s, respectively. The minimum, mean and maximum monthly flows at the weir site were worked-out as 32.17, 45.29, and 62.02m³/s, respectively.

The minimum, average and maximum daily flows at powerhouse site were found to be 13.57, 46.63, and 135.63m³/s, respectively. The minimum, mean and maximum

**Shogo-Sin Hydropower Project
Feasibility Study Report
Executive Summary**

10-daily flows at the powerhouse site were computed as 13.61, 46.27, and 132.07 m³/s, respectively. The minimum, mean and maximum monthly flows at the powerhouse site were determined as 14.04, 46.44 and 128.03 m³/s, respectively.

Floods were estimated by Regional Analysis and flood frequency approaches. For the site governing approach is flood frequency analysis being on higher side. Corresponding to 10,000 years return period, the values of floods by using Gumbel's, Log Pearson Type-III, Log Pearson and Log-normal methods and Regional analysis are 1177, 1126, 1328, 1287 and 904 m³/s for the weir site and 1225, 1173, 1383, 1340 and 944 m³/s for the powerhouse site.

The design floods for the weir site and powerhouse site are recommended as follows in Table 0.1.

Table 0.1 Design Floods for Shogo-Sin Dam and Powerhouse Sites

Return period (Yrs)	2	5	10	25	30	50	100	200	500	1000	2000	5000	8000	10000
Weir Site (m ³ /sec)	480	572	635	716	732	778	841	906	996	1067	1142	1245	1301	1328
P/H Site (m ³ /sec)	499	596	661	746	762	810	876	944	1038	1112	1189	1297	1355	1383

Elevation area capacity curves for the weir site were developed which shows that capacity of the proposed reservoir is 0.94 Mm³ (762AF) and the gross area is 7.43 hectares (18.4 acres).

Due to comparatively small height of the dam, the area/storage above spillway crest between El. 1788 m.a.s.l. to 1800 m.a.s.l. is inadequate to absorb a maximum portion of the peak discharge of a flood hydrograph. Therefore, attenuation of the peaks during routing process is not significant.

Sediment studies show that the average specific suspended sediment yield at Shogo weir site is about 377 tons/km²/year. Average suspended sediment load at weir is about 0.76 MCM (616.5 AF). Average bed load at weir site is about 0.2 MCM (160AF). Average annual sediment inflow to weir is about 0.95 MCM (774 AF).

Trap efficiency of reservoir computed on the basis of Churchill curve is 13 %. The recommended trap efficiency is 63 % based on total sands and coarse material. Average annual trapped sediment load in the proposed reservoir would be 0.76 MCM (616 AF).

Flushing discharge required to carryout flushing of the reservoir would be equal to or greater than 90 m³/s, whereas flushing duration required would be around 4-6 hours depending on the flow available for the purpose.

The life of the reservoir can be enhanced to about 60 years by constructing a boulder trap at the upstream end of the reservoir and with appropriate flushing operations at the rate of two flushings per year in the months of July and August.

It is proposed to construct a boulder trap at the upstream end of the proposed reservoir to stop the entry of boulders in the reservoir. This has been incorporated in the civil structures design.

To carry out efficient flushing, the sediment data in the reservoir should be monitored every year before flushing. Moreover, operator must be fully vigilant on the coming forecasted flows which may offer suitable flushing opportunity.

0.4 Geological and Geotechnical Investigations and Seismic Hazard Assessment

Geotechnical and geological investigations have been carried out for the Project in accordance with the norms and standards generally followed for the feasibility studies for hydropower project. These investigations included office and field work, laboratory testing, evaluation and interpretation of field as well as laboratory data. The field work comprised some 700m of drilling of boreholes at structural locations, coring and logging of bore holes, performance of field tests, surface geological mapping,, geophysical testing, and excavation of test pits.

Detailed geological mapping has been carried out in the weir area, along the headrace tunnel alignment, and in the powerhouse area. On the basis of these maps, most favorable locations of various Project structures have been selected. The valley at the weir site is approximately 120 to 130 m wide at riverbed level.

Metamorphic rocks are exposed on both banks and are mainly marble with intrusion of quartzites and impurities and occurrence of karst. Scree is observed in places at height above river bed in the weir area and mainly well downstream of the weir site due to weathering of marbles. The dip and dip direction of foliation on the left bank ranges from 48° - 85° and 40° - 190° respectively. The dip and dip direction of foliation on the right bank ranges from 40° - 88° and 30° - 315° . Joint sets are observed on both banks with spacing varying from 6 mm to 2000 mm and persistence from 2 m to 10 m. Dip and dip direction of the joint sets ranges from 10° - 88° and 15° - 315°

River bed deposits are mainly sandy gravels and boulders and fallen rock from slopes. The gravels are mostly fine to coarse grained and of igneous and metamorphic in origin.

A subsurface profile at the weir axis shown in Volume 5 – Drawings, based on surface geological mapping, drilling and in-situ testing of boreholes, geophysical investigations and discontinuity mapping indicates that adjacent to the right bank in the active river channel on, the alluvium thickness extends to approximately 30 m below the river bed whereas adjacent to the left bank, bed rock is encountered at depth of about 23 m. In the centre of the river channel the depth of alluvium extends to a depth of about 68 m before hitting rock.

On the basis of information gathered through scan line survey, rock core testing and other laboratory tests, design parameters have been established for carrying out feasibility stage design of surface and underground structures. Similarly, on the basis of information gathered from the site and laboratory testing, sources of suitable construction materials have been identified.

Detailed neo-tectonic and seismic hazard assessment has been carried out due to the proximity of the Reshun Fault which is a regional fault in Chitral district. The other two regional faults in the vicinity of the Project site include Trich Mir fault in the north and Main Karakoram Thrust (MKT). The results of these investigations have been detailed in Volume 3 – Geology, Geotechnical and Seismo-Tectonic Aspects.

0.5 Site Selection (Project Layout Studies)

Seven (7) possible alternate layouts of the project were identified on the specified stretch of Luthko River based on topography and estimated flows at the weir and intake which were checked in the field during site visits and screening of these alternatives performed by following set criteria. Based on the parameters adopted for screening viz; good topographical, hydrological and geological conditions; minimal environmental issues and capacity per meter length of waterway, the following Alternatives were screened out for further studies and investigations:

1. ALT – 01 A (Shogo-Sin)
2. ALT – 03 B (Shogo-Turshi)
3. ALT – 07 (Shogo-khura Lasht)

Topographic surveys, Geological mapping and socio-economic/environmental surveys were carried out in the field for comparison of these alternatives. Comparison level costs and power/energy estimates of each alternative alongwith economic analysis have been performed.

Based on the results of topography, geologic, hydrology and environment investigations the conditions of the components of the three alternatives were compared and more detailed comparison was made based on the results of power/energy estimates, costs comparison of preliminary economic analysis of these alternatives.

Finally the three sites were evaluated on the basis of technical, environmental and economic results and it was concluded that Alt. 07 Shogo-Sin powerhouse at Khura Lasht was the best and selected for detailed further studies which are summarized below.

It is noted that although the powerhouse is at Khura Lasht, the project will continue to be named Shogo-Sin without change in accordance with the present Contract for Feasibility Studies.

0.6 Project Sizing

For the selected Project Layout, Project sizing that is, optimization of the type of plant and its capacity, fixing of maximum reservoir level and diameters of the headrace tunnel and shaft have been performed.

The methodology of sizing/optimizations of the plant and reservoir level uses the assumed design discharges values ranging from 30 m³/s to 85 m³/s at incremental intervals of 5 m³/s. For each assumed design discharge, preliminary costs of the Project was estimated by using Hydro Power Costing (HPC) computer programme and power /energy calculations were performed which were taken as benefits of the Project. Net Present Value (NPV) calculations were performed for each discharge value, the highest NPV value was the deciding factor of the sizing/optimization process.

For optimization of the diameters of headrace tunnel and pressure shaft, different diameters of the tunnel/shaft were assumed, for each diameter the construction cost for the total length of tunnel/shaft was calculated. Also, the cost of loss of energy due to hydraulic losses (since increase of diameter results in decrease of head losses) were estimated. Then, both costs i.e. construction and energy losses costs were summed up, the diameter having lowest sum of costs was taken as the optimum.

The headrace tunnel and steel lined pressure shaft is optimized as 5.6m and 4.2m respectively.

For optimization of plant capacity run-off river and peak options were evaluated and sensitivity analysis and it was found that 4 - hour Peak plant with design discharge of 65 m³/s and plant capacity of 132 MW will be the optimum. The maximum reservoir level was optimized as 1800.0 m.a.s.l. and minimum as 1788.0 m.a.s.l.

0.7 Civil Engineering Studies

Under civil engineering studies, hydraulic analysis and sizing of project structures, computational hydraulic modeling, tunnel support design and structural analysis and design have been carried out to feasibility level design level.

Feasibility level design of the following structures have been carried out.

0.7.1 Diversion Structure:

The diversion structure on Lutkho River is concrete face rock fill dam (CFRD) with its crest level at elevation 1805 m.a.s.l. and a maximum height of 30m above river bed level. The structure has been designed to safely withstand AEP 1:10000 flood and design earthquake without damage. Care has been taken to provide defensive design measures in the structure and particularly at the plinth/face slab interface both in the river bed area and at the abutment contact areas. The lower part of the downstream rockfill face is reinforced to withstand overtopping flow.

0.7.2 Spillways

A spillway structure with a crest level of 1790.0 m.a.s.l. is located on the left bank and is equipped with two hydraulically operated radial gates for flood discharge. The spillway discharges onto a stilling basin on the downstream of the ogee crest for energy dissipation before flows are released into Lutkho River. The spillway can pass the AEP 1:10000 flood with both gates open or with one gate in-operative in conjunction with low level outlets. In the latter case the reservoir rises to its maximum level of 1801.5 m.a.s.l.

Computational hydraulic modeling of the spillway has been carried out. The results show that performance is acceptable.

0.7.3 Low Level Flushing Outlets

Two low level flushing outlets serving the dual purpose of diversion tunnels during construction have been provided on the right bank just downstream of the power intakes for reservoir drawdown and flushing of sediment from the reservoir and the front of the power intakes. The invert level of these low level outlets is set at 1775.0 m.a.s.l. The low level outlets can also be used to discharge flood in the case of extreme events as a back up to the spillway. Their discharge capacity at maximum operation level is 915m³/s.

0.7.4 River Diversion Works

In the case of Shogo Sin, since the embankment is rockfill (CFRD), best practice methodology used in Australia and elsewhere to minimize costs have been used and the diversion structures designed for the average year flood of AEP 1:2 which is a flood of 480 m³/s magnitude. The risk of overtopping will be managed by strengthening of the coffer dams and embankment to tolerate overtopping during the construction period while the main embankment is still at lower levels.

River diversion will be with upstream and downstream cofferdams with impervious cut off provided by intersecting columns of jet grouting together with diversion tunnels. The upstream and downstream coffer dams are built of gabions to withstand overtopping. As indicated above the lower section of the downstream face of the the CFRD is also reinforced to withstand overtopping. The crest elevation of the upstream cofferdam is fixed at 1785.0 m.a.s.l. and the required diameter of tunnels based on flood routing is 6.0 m without overtopping the cofferdam.

Conventional ring cofferdams with sufficient space provision for construction activities and access will be used for construction of the diversion intakes and tunnels and the power intakes and connecting tunnels.

0.7.5 Power Intakes

Two power intakes are provided on the right bank to convey a total discharge of 78.0m³/s. Orientation of the intakes in relation to the diversion structure has been set to minimize sediment entry and invert elevation has been set at 1779.8 m.a.s.l providing sufficient depth for submergence.

0.7.6 Desander Chambers

Two 220m long desander chambers have been provided to remove suspended sediment particles greater than or equal to 0.2mm from entry into the head race tunnel and consequently the hydraulic turbines. Provision has been made for continuous flushing of settled sediment from the desanding chambers back into Lutkho River.

0.7.7 Power Waterways

The power waterways consist of two connecting tunnels from each of the intakes and desanding chambers optimized for a design discharge of $39.0\text{m}^3/\text{s}$ and the low pressure tunnel, the high pressure shaft and pressure tunnel and penstocks, all optimized for a design discharge of $65\text{m}^3/\text{s}$. Temporary and permanent lining for the power waterways have been provided.

0.7.8 Surge Chamber

For regulation and response to load changes at the turbine/generators it has been found necessary to provide a surge tank. A surge tank diameter of 12.0m for surge tank stability and height 76m to cater for maximum upsurge at turbine load rejection.

0.7.9 Penstocks

Three 1.85m diameter penstocks have been provided downstream of the pressure tunnel after twin bifurcations to connect to the turbine inlet valves and turbines. Penstock transient analysis has been carried out to provide for rapid wicket gate closure and pressure will rise in the penstocks.

0.7.10 Power House Complex

The powerhouse layout accommodates the main power generating electromechanical plant and the ancillary plant for operation and maintenance and comprises of the surface powerhouse, transformers bay and Gas Insulated Switchgears (GIS) building.

The powerhouse building houses three Francis turbine units each comprising main inlet valve and the turbine and generator. The vertical axis Francis turbine is coupled directly to a generator, their auxiliary plant, the generator circuit breakers, isolators and unit transformers. The powerhouse also accommodates the main drainage sump, battery rooms, mechanical and electrical workshops. The transformer bay houses nine transformers (three each for a unit) and one spare transformer.

0.8 Hydro-Mechanical Studies

0.8.1 Turbines and Ancillaries

Francis turbines are the most suitable turbine type for the net head available at the Shogo Sin Project. Three Francis turbines have been proposed to give reliability of service and to meet the energy demand during both summer and winter seasonal flows. Because of their size, that is, each turbine is 45 MW, the turbine must be of the vertical type. To accommodate likely high sediment loadings that the turbines must pass, coating of turbine runners with tungsten carbide is proposed. Moreover closed circuit cooling water systems have been recommended to alleviate clogging of water pipes by sediment. Access to the powerhouse has been provided so that a turbine runner can be quickly dismantled and taken to the Erection Bay Floor for repair. One spare runner will be held in store to enhance machine availability.

0.8.2 Spillway and Low Level Outlets

Shogo Spillway will be incorporate with two radial type spillway gates to pass high reservoir inflows. Seasonal flows greater than those drawn from the reservoir for power generation will be released firstly through two low level outlets to flush any sediment build-up in front of the Power Intakes. These two low level outlets will be used as diversion tunnels to divert river flow during the construction period. Each low level outlet will have a fixed wheel gate to control releases. At the intake and outlet of each low level outlet stoplogs will be provided for inspection and maintenance of the tunnel and gates. The spillway gates will be operated as necessary to pass excess flows.

0.8.3 Power Intakes

Two power intakes have been provided, each is connected to a downstream desander. The intakes include upstream trashracks, provision for stoplogs and a guard gate. Guard gates are of the fixed wheel type and will be capable of closing under full tunnel flow. A trashrake and gantry crane have been provided on the Power Intake service deck for cleaning trashracks, handling the stoplogs and maintaining the gate.

0.8.4 Desander Basins

Desanders have been provided to control sediment entry into the turbines. The desanders comprise of two chambers. Each desander has been provided with isolating gates and stoplogs to permit inspection and maintenance tasks. The pair of slide type flushing gates (one service, the other maintenance) has been provided in the flushing outlets of each desander for continuous or intermittent flushing of sediment while the power tunnel is in operation. The stoplogs provided at each desander chamber outlet will be handled with a bridge crane. Sediment flushed from the desander will be discharged back to the Lutkho River downstream of the dam.

0.8.5 Powerhouse Equipment

Temperatures and humidity in the Powerhouse will be controlled by a forced, re-circulating / exhaust ventilation system. Chilled water will reticulate around the powerhouse to assist cooling of air and the removal of heat around the plant. Through-the-wall' type air conditioners will be provided in the control room for the comfort of station operating personnel and for the protection of control equipment. Should a fire erupt, suppression of the fire will be affected by a combination of water spray and CO₂ fire extinguishers. Pressurization of stairs has been provided for the safety of personnel. A fire in a generator or transformer cell will be extinguished by the automatic release of argonite.

Draft tube gates operated by gantry crane will be required to facilitate, maintenance, inspection and repair of each turbine.

0.9 Electrical Engineering Studies

0.9.1 Electrical Equipment

The hydrological, mechanical and economical studies have led to the conclusion that three Francis turbines with synchronous speed of 428.6 rpm fulfil the conditions given by net head and design flow.

The total installed capacity of the project has been fixed as 132 MW.

The following main equipment has been selected.

0.9.2 Generator

Three vertical shaft synchronous generators with the following main design features have been selected.

Main Design Features

Capacity	:	51.8	MVA
Out put	:	44	MW
Power Factor	:	0.85	lagging
Rated Voltage	:	11	kV
Rated speed	:	428.6	rpm

A static, thyristor controlled excitation system with high speed Automatic Voltage Regulator will be provided for each generator.

Each generator will be provided a completely independent fire detection and fire protection system. Argonite will be used as fire suppression medium.

0.9.3 Isolated Phase Bus Duct (IPB)

The electrical connection between the generator and step-up transformers will be enclosed in isolated phase bus ducts. The system will be designed for natural cooling. Each enclosure will be air pressurized with dedicated air compressor.

0.9.4 11 / 132 / $\sqrt{3}$ kV Step-up Transformers

The generators will be directly connected with the single phase, step-up transformers via IPB. The transformers have been proposed to be single phase keeping in view the transportation limits. These will be placed at transformer bay on the upstream of the powerhouse building taking all required fire protection measures.

Main Design Features

Type of construction	:	single phase, two windings
Capacity	:	17.3 MVA
Voltage ratio	:	11 / 132 / $\sqrt{3}$ kV

0.9.5 132 kV High Voltage Cables

Each step-up transformer will be connected to the 132 kV switchyard via single core, single phase 132 kV, XLPE cables.

The fire protection arrangement in the cable gallery will be made as per NFPA 851.

0.9.6 Protection Equipment

Separate relay protection cubicles comprising numerical relays will be installed. The relays will be organized in two groups so that one group provides back up protection for the other. The control supply will be taken from 110 VDC system.

0.9.7 Station AC Auxiliary Supply

The medium 11 kV and low voltage (400 VAC) installations have been planned to provide a reliable AC supply for all functions of the power house. Emergency diesel generator has been planned for providing AC auxiliary supply in case of a breakdown to ensure a safe shutdown or black start up of the plant.

0.9.8 110 V DC Supply

The DC system will be provided to supply uninterruptible power for control, protection, protection instrumentation, and other specific controls and critical DC operated equipment. Two independent 110 V DC systems will be provided for this purpose.

0.9.9 Plant Control System

The control room has been equipped with Plant Control System (PCS). Local computerized control units inside the powerhouse and intake area have been specified to perform all automatic functions and have been connected to the PCS by a fibre optic bus.

All equipment and systems have been specified in accordance with state of the art technology and proven reliability.

0.10 Power and Energy Potential

With the optimized reservoir levels of 1800.0 m.a.s.l. and 1788.0 m.a.s.l. hydrological estimates, compensation releases and rating curves at weir and powerhouse sites, the power and energy estimations of the Project have been performed with following basic assumptions:

- The residual flows in Lukhto River during low flow period has been taken as 0.75 m³/s. It is based on provision of water for sediment flushing requirements and minimum flows required in the river for environmental purpose; and will be released through out the year, even during the low flow periods.
- The variations in the efficiencies of generating units due to change of net heads have not been considered. For design discharge available to powerhouse, efficiencies of 92.5%, 98.0% and 99% have been used for the turbines, generators and transformers, respectively.
- The head loss has been considered as 12.62 m to estimate net head at the turbines. The losses would be less for a discharge less than the design discharge. The rated net head is 231 meters.
- Sediment flushing is assumed to be carried out every year during summer months. The maximum flow in the river occurs from June to August. The sediment flushing would be carried out when the flows in Luthko River are more than power generation design discharge.
- During low flow periods, when the discharge in the River is less than 65 m³/s, the live storage is used to store water during off peak hours to improve the flows for power generation in peak hours.
- Energy is calculated on 10-daily basis by multiplying the number of days by 24 hours (in a day). For power and energy during peak and off peak hours, the volume of water available for storage and inflow volume in 24 hours is used to calculate the corresponding discharge. The power during peak and off peak hours is used to calculate the corresponding energy.

The calculated annual energy, for years 2003 (average year), 2005 (wet year) and 1982 (dry year), is 583.68, 514.72, and 654.03 GWh respectively.

For the purpose of this study, average annual energy is taken as 583.68 GWh produced in the “average year” 2003.

0.11 Power System and Transmission Studies

0.11.1 Power System Study

Based on the data supplied by PEPCO, regarding future system demand and generation expansion program, balance of Demand/Supply was worked out with and without Shogo-Sin Hydropower Project. The results establishes that project mitigate Deficit and increases the reserves to some extent.

0.11.2 Transmission Study

In order to transmit power generated at Shogo-Sin Hydropower Project to the National Grid, a reliable, economical and viable transmission system has been proposed after considering different alternatives. A detailed physical survey was carried out to find suitable corridor for the proposed transmission lines. Based on this site survey, proposed line route has been described in the section. Furthermore, after cost comparison for different voltages and type of conductors, 132 kv double circuit with Greely conductor up to the proposed Chitral grid station, has been found most economical interconnection scheme for Shogo-Sin Hydropower Project.

0.11.3 Load Flow Study

Peak Load and Off Peak Load cases for year, 2015 were simulated and studied. For these studies, the system was modeled representing the entire grid of NTDC and Discos, comprising 500 Kv,220 Kv,132 kv and 66 kv levels and all the generating stations existing as well as future, planned to be commissioned by June 2015 as per PEPCO's future Generation program. Since the project will be feeding NTDC grid through Radial lines, there will be no problem in power evacuation, even if commissioning of the project is delayed beyond June, 2015.

A state-of-the-art software PSS/E of Siemens-PTI has been used for load flow, short circuit and stability studies.

The results of load flow studies for normal and contingency cases both for Peak and Off Peak indicate steady state performance of the proposed interconnection scheme for Shogo-Sin, Shushghai-Zhendoli, Golen Gol and Swat Hydropower Projects taken together and certainly more than adequate, if considered individually for each project.

0.11.4 Short Circuit Study

Short circuit studies were carried out with maximum generation dispatch in the system so as to have maximum fault currents. The results indicate that the proposed hydropower plants on tributaries of Chitral River do not increase the fault levels of main grid stations of the system and the fault currents remain within the rated capacities of their equipments.

0.11.5 Transient Stability Study

In order to test the strength of the proposed inter connection scheme against the severe system disturbances, Transient Stability studies have been carried out. Stability studies have been carried out for following cases,

Case 1- Three phase fault at Shogo-Sin 132 kv bus bar, cleared in 5 cycles (normal clearing) followed by permanent trip of 132 kv Shogo-Sin-Chitral Single circuit.

Case 2- Three phase fault at Shogo-Sin 132 kv bus bar, cleared in 9cycles (Stuck breaker or breaker failure) followed by permanent trip of 132 kv Shogo-Sin-Chitral Single circuit.

The results indicate that in both cases, the system remains Stable, although there are initial swings on the generators as well as intact Transmission lines, which damp down smoothly and quickly.

0.11.6 Design and Engineering of Proposed Interconnection Scheme

Transmission Line

The basic design requirements for the proposed transmission lines, to be constructed by Power Purchaser for interconnection of the project with National Grid, has been described, which includes, line conductor, towers, insulators and minimum line clearances of lines required from safety point of view. Details are given in Section 12 and Volume 5 – Drawings.

132 kv Switch yard of the Project

Due to space limitation, conventional out door switchyard can not be provided for the Project. As such 132 kv switch yard having Indoor Gas Insulated Switchgear (GIS) has been proposed for the Project. There will be three GIS bays for three generator step up transformers, two for out going transmission lines and one for 132/11 kv,20/26 MVA station service transformer. Station Service Transformer, Gantry for transmission lines, termination from GIS bays for connection to over head transmission lines and station service transformer, Surge Arrestors, capacitive voltage transformers etc. will be installed outside GIS room,

All the switch yard equipment will be designed for following rating;

1.	Nominal Service Voltage	132kV
2.	Maximum system Voltage	145kV
3.	Rated Frequency	50Hz
4.	System Grounding	Solid ground
5.	Rated Short time Current	40KA
6.	Rated Peak time Current	127KA
7.	Nominal current of the main bus-bar and conductor	4000A
8.	Rated impulse withstand voltage (Peak Value)	650 KV

Basic design requirements of major GIS equipments, like Bus bar, Circuit breakers, Disconnect switches, Earthing Switches, Instrument Transformers etc. has been explained in the relevant subsections of Section12.

0.12 Socio-Economic and Environmental Studies

The main baseline conditions for Shogo-Sin Hydropower Project were studied covering upper area of project, reservoir area, dam site located at Shogore Village, intake structures area and power house site located at Khura Lasht village.

The environmental water requirement releases from project dam site to downstream is 0.75 cumecs (26.5 cusecs) during low flow period. This will fully meet the environmental requirements of downstream areas. This will be joined with other inflows from streams and nullahs to meet the environmental requirements of downstream reach of the river from dam site to Khura Lasht.

Majority (80%) of the farmers in the Chitral district have small landholdings ranging from 0.5 to 1.5 ha dependent on rainfed agriculture. Based on the acquisition of land and average land holding (1.5 acres) only, 5 households/families with an average of 7.5 members/ family 38 persons will be affected by land only. The agriculture income is supplemented by income from livestock.

Shogo-Sin Hydropower Project will spread over two main areas (i) Reservoir area at Shogore upper end and (ii) Power house at Khura Lasht at the lower end. Reservoir area will cover over 6.88 ha (17.0 acres) while powerhouse and switchyard will cover over 0.41 ha (1.0 acres). This project will have impacts at submergence level of EL. 1800 m.a.s.l. The project colony and offices will occupy 2.63 ha (6.50 acres) and road alignment will need 0.61 ha (1.5 acre). Overall, the project will require 10.52 ha (26.0 acres) permanently. Only 3.5 acres of irrigated and 4 acres barren/rocky private land will come under project implementation. The rest of land belongs to the government for which no land compensation is needed. 150 plants (135 forest and 15 fruit) will also be affected. There will be insignificant impact on wildlife during construction.

The major adverse impact of the project will be on the 13 km stretch of river length downstream dam site. The diversion of water for most of the time through power tunnel to power house site. This will leave this river length dry. Compensation water of 26.5 cusecs is proposed. The other adverse impacts arising are, (i) changes in river bed morphology downstream, (ii) reduction in the aesthetic value of 13 km

length of Lutkho River downstream reservoir, (iii) increased flood levels and frequency during head pond flushing and (iv) some minor impacts on flora and wild life are likely to occur.

During construction, the monitoring will be done for air quality, noise and vibration, drinking water quality, sewage effluent, solid waste, explosive material used, hazardous/toxic materials and its proper disposal, flora/fauna, excavated material and traffic handling systems etc. The internal and external environmental monitoring is very important component during the execution of this project especially due to the introduction of tunnel technology. Mitigation measures for these issues have been included in the EMP.

The environmental cost amounts to Rs.11.32 millions.

The project is environmental friendly and it will contribute substantially in the economy of Pakistan. The project will have major positive socio-economic impact on the population living on the periphery of the reservoir and on person living off site the project area. The benefits of emoluments during construction, better transportation means created by the project and economic activities generated has a spin-off positive impact on whole of Chitral area.

0.13 Project Implementation and Construction Planning

Project implementation period is estimated to be 5 years (Phases II and III overlap) excluding pre-construction activities as given below

- **Phase I: Pre-Construction Activities and Award of Contract on EPC Basis.**

Completion Period: 24 months are required

- **Phase II: Project Construction Works with Detailed Engineering Design of Project Components**

Completion Period: 60 months will be consumed for completion of all the components of the Project works.

- **Phase III: Testing and Commissioning of Turbines**

A period of 4 months will be required for accomplishment of the requisite tests which will be carried out simultaneously within the time schedule of Phase II.

Details of project implementation and construction planning are given in Section 14 of the Main Report and Volume 5 – Drawings.

0.14 Bill of Quantities and Cost Estimates

The Bill of Quantities and cost estimates for various works including Infrastructure development and site installations, Civil, Hydro-mechanical, Hydraulic Steel Structures, Electrical & Substation were prepared by multiplying unit rates with the relevant quantities of different structures. The Cost estimate for Environmental Mitigation Programme was prepared after collection of data during site visit and evaluated and then estimated.

The methodology applied to the estimation of cost is carried out proceeding the following steps in accordance with the requirements of a bankable feasibility study.

- Define Basis of Cost Estimation
- Estimate Basic Project Cost
- Estimate Costs of Engineering, Administration, Erection, Transportation etc
- Determine Bill of Quantities
- Estimate Total Project Costs

Basic costs of labor, material, consumables and equipment were inquired, unit costs calculated and compared with unit rates of hydropower projects of similar size and type presently under development in Pakistan.

The unit and lump sum prices for Civil Works were prepared after doing rate analysis for various items and consulting and escalating the unit prices for certain items given in the feasibility study of Golen Gol Hydropower Project. The unit rates were taken from the above said project and then escalated at the rate of 6.5% per annum.

All prices are quoted in Pakistan Rupees. For Local & Foreign cost component the rate of 1 US\$ = Rs. 84.50 on January 2010 price level has been adopted.

The cost for Infrastructure improvement / development, Environmental Mitigations, Land compensation, Preparatory works and Site Installations is estimated as **11.184** Million US\$.

Based on the feasibility design as documented by the corresponding design drawings the Consultants have calculated the quantities of the major civil structures. For minor works provisions in terms of the miscellaneous items rates have been made. Cost of civil works is estimated as **92.835** Million US\$.

Cost of Hydro-mechanical and Electrical equipments is based on budgetary prices from reputed manufactures both local and foreign. The cost of Hydro-mechanical equipment is estimated as **22.116** Million US\$ and that of Electrical equipment is estimated as **31.850** Million US\$.

The cost of Hydraulic Steel structures is estimated as **10.447** Million US\$.

The Substation cost of Shogo-sin HPP is estimated as **5.375** Million US\$.

The total cost of the project by summing up all the costs mentioned above is presented below:

Total Cost (PKR) **16,384.05 Million Pak Rupees**

Total Cost (US\$) **193.894 Million US\$**

0.15 Economic and Financial Analysis

Economic analysis carried out indicate that the plant would be economic if benefits were the long run marginal costs (LRMC) of supply , this implies that the plant would form a part of the least cost expansion plan and is therefore feasible on that count. The NPV for the project at 12% interest rate was US\$M 42 and the IRR 15.53%.

Since there is uncertainty related to the assumptions and inputs, a sensitivity analysis was carried out and is summarized as follows in Table 0.2.

Table 0.2 Economic Sensitivity Analysis Based on LRMC

Sensitivity Analysis		NPV M.\$ at 12%	IRR %
1	Base Case	42	15.53
2	Cost +10%	32	14.62
3	Benefit -10%	24	14.11
4	Cost +10%,Benefit -10%	13	13.05

Economics of the project were verified on basis of benefits quantified as Willingness to Pay basis and gave an NPV of US\$M 29 at 12% interest rate and an IRR of 14.05%

Sensitivity analysis was carried out and is summarized as follows in Table 0.3.

Table 0.3 Economic Sensitivity Analysis Based on WTP

Sensitivity Analysis		NPV M.\$ at 12%	IRR %
1	Base Case	29	14.05
2	Cost +10%	17	13.14
3	Benefit -10%	11	12.77
4	Cost +10%,Benefit -10%	-2	11.89

The project seem to be feasible on central assumptions , on 10% reduction of benefits and on 10% increase of costs , the project is however marginally unfeasible if costs increase by 10% and benefits decrease by 10 %.

The economic internal rate of return (EIRR) and the economic net present value (ENPV) for the proposed project have been calculated. LRMC at 132 kV level were used as avoided costs and the economic feasibility of the plant was established. The benefits were also estimated on basis of 68.83 % of the WTP which resulted in the WTP at generation level to be Rs.5.95 c/kWh.

The project seems to be feasible on both counts, the economic feasibility when benefits were quantified on basis of LRMC signifies the inclusion of the plant in the least cost expansion plan as LRMC are derived using the long term expansion

program as an input .The project is sensitive, however, to changes in benefit and cost parameters and in case of 10% increase in cost and 10% reduction in benefits the project is only marginally feasible.

The financial analysis of the proposed hydropower plant has been carried out in accordance with the Asian Development Bank's (ADB) *Financial Management and Analysis of Projects*. All financial costs and benefits have been expressed at early 2010 constant prices. Cost streams used for the purposes of financial internal rate of return (FIRR) determination (i.e., capital investment, operations and maintenance, insurance costs and taxes) reflect costs of delivering the estimated benefits. The NEPRA approved tariff for Khan Khwar, a high head hydroelectric project, was used to estimate the financial benefits.

The financial internal rate of return (FIRR) was calculated at 9.22% for the project. The overall rate compares favorably with the estimated WACC of 8.93%, substantiating the financial viability of the project.

The project seems to be financially feasible. Risks are quantified by the sensitivity analysis as below in Table 0.4.

Table 0.4 Financial of Sensitivity Analyses Results

Item	FIRR (%)
Base case	9.22%
20% increase in capital cost	7.33%
20% increase in O&M cost	6.92%
20% decrease in wheeling charges	5.15%

The project is financially feasible on central assumptions, the project is sensitive to cost overruns and decrease in tariffs. The above analysis, however, have been carried out on benefits/tariffs significantly less than the calculated tariff for the plant, at which the project will be feasible financially and will be robust and will be able to stand reasonable uncertainties.

The project seems to be both economically and financially feasible. The project is , however, sensitive to cost overruns

0.16 Conclusions and Recommendations

The project is technically, economically and financially viable.

The Shogo-Sin HPP is feasible and beneficial to continue to develop until project implementation.

The following recommendations are made to ensure that the required investigations for detailed design are made and consideration given to project implementation methodology.

0.16.1 Hydrological Investigations

Long term hydrological and meteorological information is not available at the weir site at Shogo and the power house site at Khura Lasht. Systematic measurements were able to be made only for the durations of this Feasibility Study which covered only a period of about 01 year. It is recommended that measurement stations be established and flow and sediment measurements, river gauging and meteorological measurements be carried out commencing from 2010 so as to provide as much data as possible for detailed design stage.

0.16.2 Geotechnical Investigations and Testing

The time and funding available for geotechnical investigations did not permit drilling investigations along the tunnel trace, adit tunnel or access tunnel traces. It is recommended that these investigations be carried out.

It is also recommended that in-situ testing such as in adits, direct in-situ shear tests etc. be carried out at detailed design stage to supplement data obtained during this Feasibility Study.

0.16.3 Physical Hydraulic Modeling

It is recommended that physical hydraulic modeling of the headworks structures and sedimentation basins be carried out at detailed design stage to confirm,

- Alignments of the headworks structures,
- Functioning of the low level outlets at the weir for sediment flushing,
- Spillway and low level outlet energy dissipation, and,
- Functioning of the sedimentation basins for efficiency of sediment settlement and flushing.

0.17 Project Configuration

The Project concept is based on generation of electric power by diversion of part flow of Lutkho River by means of a diversion structure located across the River via a power tunnel to a powerstation located on Lutkho River near Khura Lasht village utilizing a head of some 236m available in the steep stretch of river. The Project has been planned to develop the available head by means of a run-of-the river peaking scheme generating 132MW of power.

The Project configuration consists of the following major components:

- Diversion weir of 30 m height from river bed comprising of concrete gravity weir/embankment with low level outlets, un-gated and gated spillways
- Lateral power Intake structure on right bank of river that comprises two intakes to take the design and flushing discharge of 78 m³/s to the desanders
- Two connecting tunnels each of 4.5 m dia. to take the discharge from intake to desanders
- Transitions of length of 25 m. starting from the end of connecting tunnels and ending at the start of desander chamber.
- Two underground desanders 220m long starting from the end of transitions
- Low pressure headrace tunnel of total length of 7590 m of 5.6 m diameter.
- Vertical surge shaft of 12 m dia. with height of 76 m

- Concrete lined pressure shaft of 5.20 m diameter having total length of 142 m
- High pressure tunnel of 4.2 m diameter having a total length of 390 m
- Penstocks of 1.8 m diameter having a length of 80 m
- Underground powerhouse with transformer cavern
- Free flow tailrace Channel of length 30 m length

The diversion structure on Lutkho River is concrete face rock fill dam (CFRD) with its crest level at elevation 1805 m.a.s.l. and is 30m above river bed level. The structure has been designed to safely withstand AEP 1:10000 flood and design earthquake without damage. Care has been taken to provide defensive design measures in the structures and particularly at the plinth-face slab interface. The lower part of the downstream rockfill face is reinforced to withstand overtopping. Detailed are shown in Volume 5 – Drawings.

The spillway structure is equipped with two hydraulically operated radial gates for flood discharge. The spillway discharges onto a stilling basin on the downstream of the ogee crest for energy dissipation before being released into Lutkho River. Provision has been made to close off each spillway bay stoplogs for maintenance work.

Two low level flushing outlets serving the dual purpose of diversion tunnels during construction have been provided on the right bank just downstream of the power intakes.

Foundation seepage control for the structures has been provided by a plastic concrete cutt-off wall 1000 mm extending from the upstream plinth into the foundation and by a grout curtain extending into the rock at the rock abutments. The guide wall to the spillway is founded on piles extending into the rock and the cut off is tied to the piles to provide an impermeable barrier.

Considerable sediment inflow is expected into the reservoir during the glacier/snow melt runoff and also during rains. In order to maintain the power intakes free of sediment build up, it is located close to the dam and the two low level outlets which have been provided on the right abutment just downstream of the power intakes. The concrete spillway section and the two low level outlets will be used to periodically flush sediment from the reservoir.

Due to the high river bed gradient it is expected that large size boulders will roll along the river bed towards the weir with a consequent possibility of blocking the bottom outlets. To prevent this occurring, provision has been made to clear the reservoir bed area of all movable boulders at construction stage and dispose to waste or other use before impoundment of the reservoir. Provision has also been made to build a low “flow-through” rockfill boulder trap at the upstream end of the reservoir to trap any moving boulders or bed material.

River diversion of Lutkho River during construction of the rock-fill dam and concrete spillway structure will be accomplished by the construction of upstream and downstream cofferdams with impervious cut off provided by intersecting columns of jet grouting together with diversion tunnels. The upstream and downstream coffer dams are built of gabions to withstand overtopping. As indicated above the lower section of the downstream face of the the CFRD is also reinforced to withstand overtopping.

Conventional ring cofferdams with sufficient space provision for construction activities and access will be used for construction of the diversion intakes and tunnels and the power intakes and connecting tunnels.

The headrace commences at the twin intakes on the right bank connecting to two desanding basins by two connecting tunnels and thereafter to the low pressure tunnel. Two adits are planned to ensure additional construction faces and expedite completion of the low pressure tunnel. The desanding basins are provided with flushing tunnels and gates for evacuation of sediment. Gates have also been provided at the downstream end for closing off each basin as required for maintenance while allowing one basin to operate and enable reduced power generation.

At the downstream end of the low pressure tunnel a surge shaft is provided to limit pressure rise in the in the waterway system and allow flexibility in power plant operation. A vertical pressure shaft and horizontal pressure tunnel and short penstocks lead to three vertical shaft Francis Turbines arranged in on-ground powerhouse. The steel lined pressure tunnel and penstocks have been kept short to achieve economy. Transformers are arranged in a GIS open switchyard. The switchyard is above ground located near the powerhouse. A 30m long tailrace releases generation flows back to the Lutkho River near Khura Lasht village.

Further design details are provided in Volume 5 – Drawings of the Feasibility Report and in Sections 8 to 10 of the Main Report.

0.18 Salient Features

The salient features of the project as per feasibility level designs are given below:

Hydrology (Design flows)		
Design discharge	65	m ³ /s
Flushing discharge	13	m ³ /s
Design flood (10,000 Year Flood)	1328	m ³ /s
Reservoir		
Reservoir length	700	m
Reservoir area	74300	m ²
Max. reservoir operating level	1800	m.a.s.l
Min. reservoir operating level	1788	m.a.s.l
Reservoir capacity at 1800 m.a.s.l	0.937	MCM
Reservoir capacity at 1788 m.a.s.l	0.272	MCM
Weir Structure		
Weir height	30	m, above riverbed
Weir crest level	1805	m.a.s.l
Spillways		
<i>Gated surface spillways</i>		
Number of gates	2	Nos.
Gate Type	Radial gate	
Width of gate	10	m
Height of gate	11	m

**Shogo-Sin Hydropower Project
Feasibility Study Report
Executive Summary**

Discharge capacity	1328	m ³ /s
<i>Diversion tunnel / Undersluices</i>		
No. of outlets	2	Nos.
Gate type	Vertical lift gate	
Gate size (WxH)	4.75 x 6.1	m
Discharge capacity	480	m ³ /s
Power Waterways		
<i>Power Intake</i>		
Type	Lateral intakes	
No. of gates	2	
Gate size (WxH)	3.60 x 4.5	m
Deck elevation	1805	m.a.s.l
Intake sill level	1779.8	m.a.s.l
<i>Connecting Tunnels</i>		
Diameter	4.5	m each
Lengths	225, 235	m
<i>Desanders (Underground)</i>		
No. of chambers	2	Nos.
Size of chamber (WxH)	10 x 16	m each
Length of chamber	220	m each
<i>Low Pressure Headrace Tunnel</i>		
Diameter	5.6	m
Length	7590	m
<i>Surge Shaft</i>		
Diameter	12	m
Height	76	m
<i>Pressure Shaft</i>		
Concrete Lined		
Diameter	5.2	m
Length	142	m
Steel Lined		
Diameter	4.2	m
Length	70	m
<i>High Pressure Tunnel (Steel Lined)</i>		
Diameter	4.2	m

**Shogo-Sin Hydropower Project
Feasibility Study Report
Executive Summary**

Length	390	m
Penstocks		
No. of penstocks	3	
Diameter	1.85	m
Total Length of 3 penstocks	80	m
Power Generation		
Gross head (HWL-Turbine centre line)	248.5	m
Max. Net head	247	m
Min. Net head	221.67	m
Rated. Net head	231	m
Plant Design discharge	65	m ³ /s
Installed plant capacity	132	MW
Turbine Type	Francis vertical	GWh
No. of units	3	
Turbiner centre line level	1547	m.a.s.l
Generator	3	
Design Annual Energy	583.92	GWh
Power house type	Surface	Nos.
Size of powerhouse (LxWxH)	63 x 20 x 32	m.
Transmission line type	Indoor GIS	
Transmission line	132	KV
Tailrace Channel		
Size of channel	34 (W) x 15 (H)	m
Length of tailrace tunnel	30	m
Additional Project Parameters		
Total project cost including IDC	231	million US \$

FIGURES

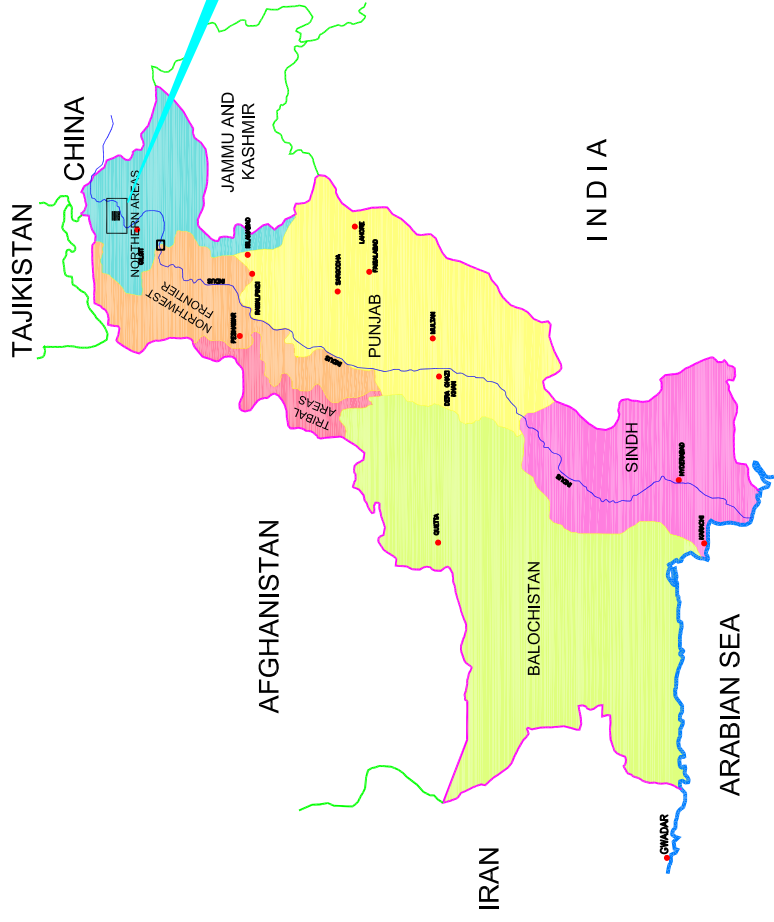

MAP OF PAKISTAN

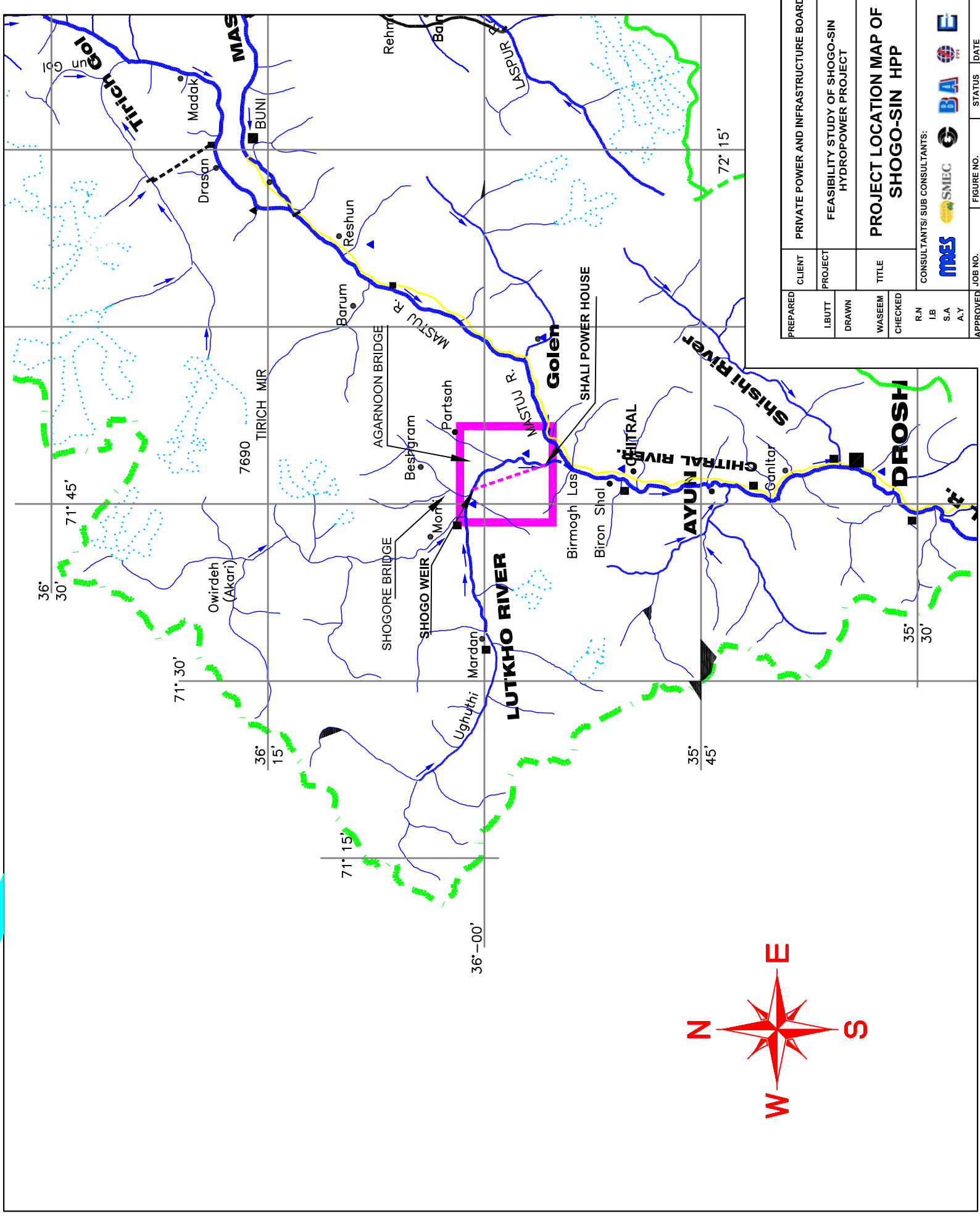

PREPARED	CLIENT	PRIVATE POWER AND INFRASTRUCTURE BOARD
LIBUTT	PROJECT	FEASIBILITY STUDY OF SHOGO-SIN HYDROPOWER PROJECT
DRAWN	TITLE	PROJECT LOCATION MAP OF SHOGO-SIN HPP
WASEEM	CHECKED	CONSULTANTS/ SUB CONSULTANTS:
	R.N	MES
	I.B	SMEC
	S.A	BA
	A.Y	E
APPROVED	JOB NO.	SS214/506933
MAES	FIGURE NO.	0.1
	STATUS	FINAL
	DATE	30-03-2010

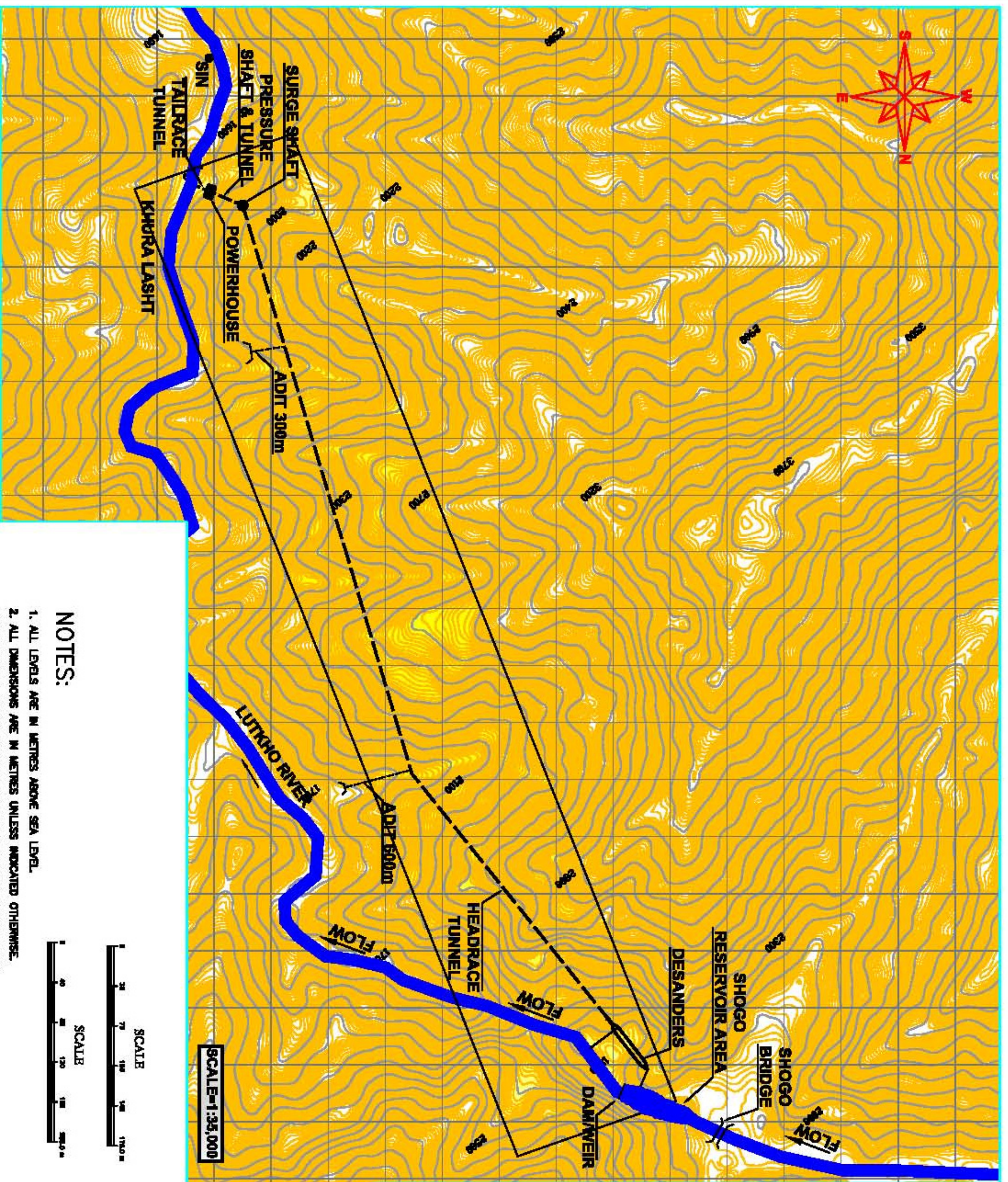

NOTES:

1. ALL LEVELS ARE IN METRES ABOVE SEA LEVEL.
2. ALL DIMENSIONS ARE IN METRES UNLESS INDICATED OTHERWISE.
3. THE SCALES SHOWN ARE FOR A DRAWING PRINTED ON A3 PAPER.

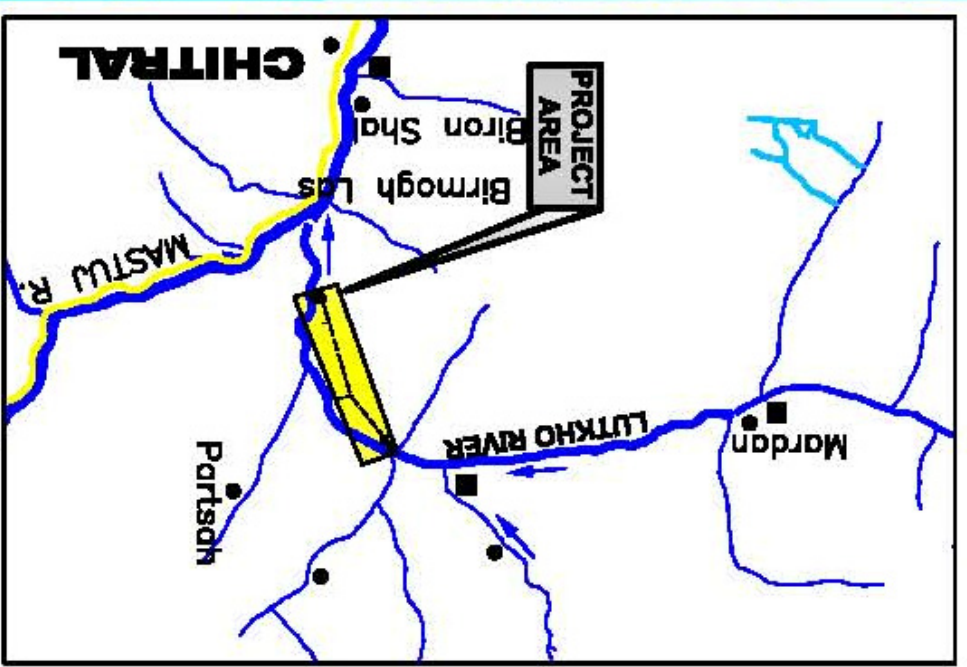
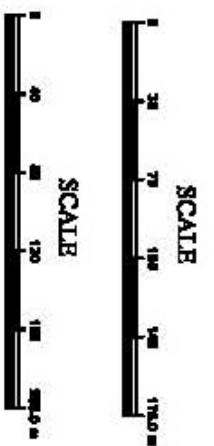

KEY PLAN
SCALE=1:40,000

LEGEND

RIVER	
TRIBUTARY	
TUNNEL	
SURGE SHAFT	
POWERHOUSE	
MAIN VILLAGE	
MAIN TOWN	
PROJECT AREA	

APPROVED	DATE	BY	FOR
DESIGNED	DATE	BY	FOR
CHECKED	DATE	BY	FOR
PROJECT	DATE	BY	FOR
CLIENT	DATE	BY	FOR
<p>PRIVATE POWER AND INFRASTRUCTURE BOARD FEASIBILITY STUDY OF SHOGO-SIN HYDROPOWER PROJECT PROJECT AREA WITH LAYOUT</p>			
<p>CONSULTANTS (PVT) LTD. (CONSULTANTS) </p>			
APPROVED	DATE	BY	FOR
DESIGNED	DATE	BY	FOR
CHECKED	DATE	BY	FOR
PROJECT	DATE	BY	FOR
CLIENT	DATE	BY	FOR

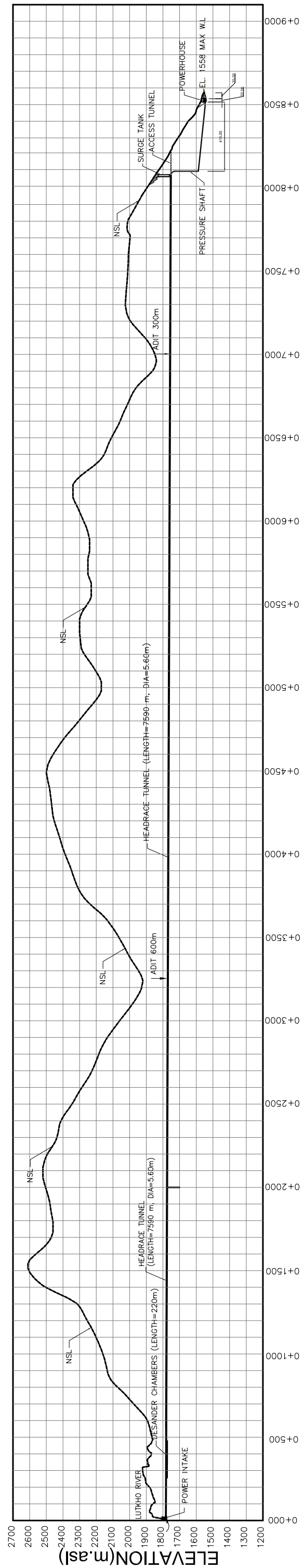

DISTANCE (m)

NOTES:

1. ALL LEVELS ARE IN METRES ABOVE SEA LEVEL.
2. ALL DIMENSIONS ARE IN METRES UNLESS INDICATED OTHERWISE.

PREPARED	CLIENT	PRIVATE POWER AND INFRASTRUCTURE BOARD
DRAWN	PROJECT	FEASIBILITY STUDY OF SHOGO-SIN HYDROPOWER PROJECT
CHECKED	TITLE	SHOGO-SIN HPP LONGITUDINAL PROFILE
R.N	CONSULTANTS/SUB CONSULTANTS:	
I.B		
S.A	JOB NO.	SS/214/0506/033
A.Y	FIGURE NO.	0.3
APPROVED	STATUS	FINAL
MAES	DATE	30-03-2010

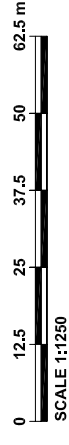
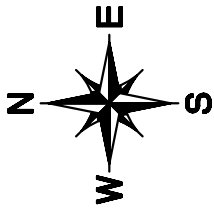

PREPARED	CLIENT	PRIVATE POWER AND INFRASTRUCTURE BOARD
E.BUTT	PROJECT	FEASIBILITY STUDY OF SHOGO-SIN HYDROPOWER PROJECT
DRAWN	TITLE	DAM / WEIR PLAN VIEW
SHOAB	CHECKED	CONSULTANTS/SUB CONSULTANTS:
R.N	LB	MES
S.A	A.Y	SMIEC
MAES	APPROVED	BA
	APPROVED	E
	FIGURE NO.	0.4
	STATUS	FINAL
	DATE	30-03-2010

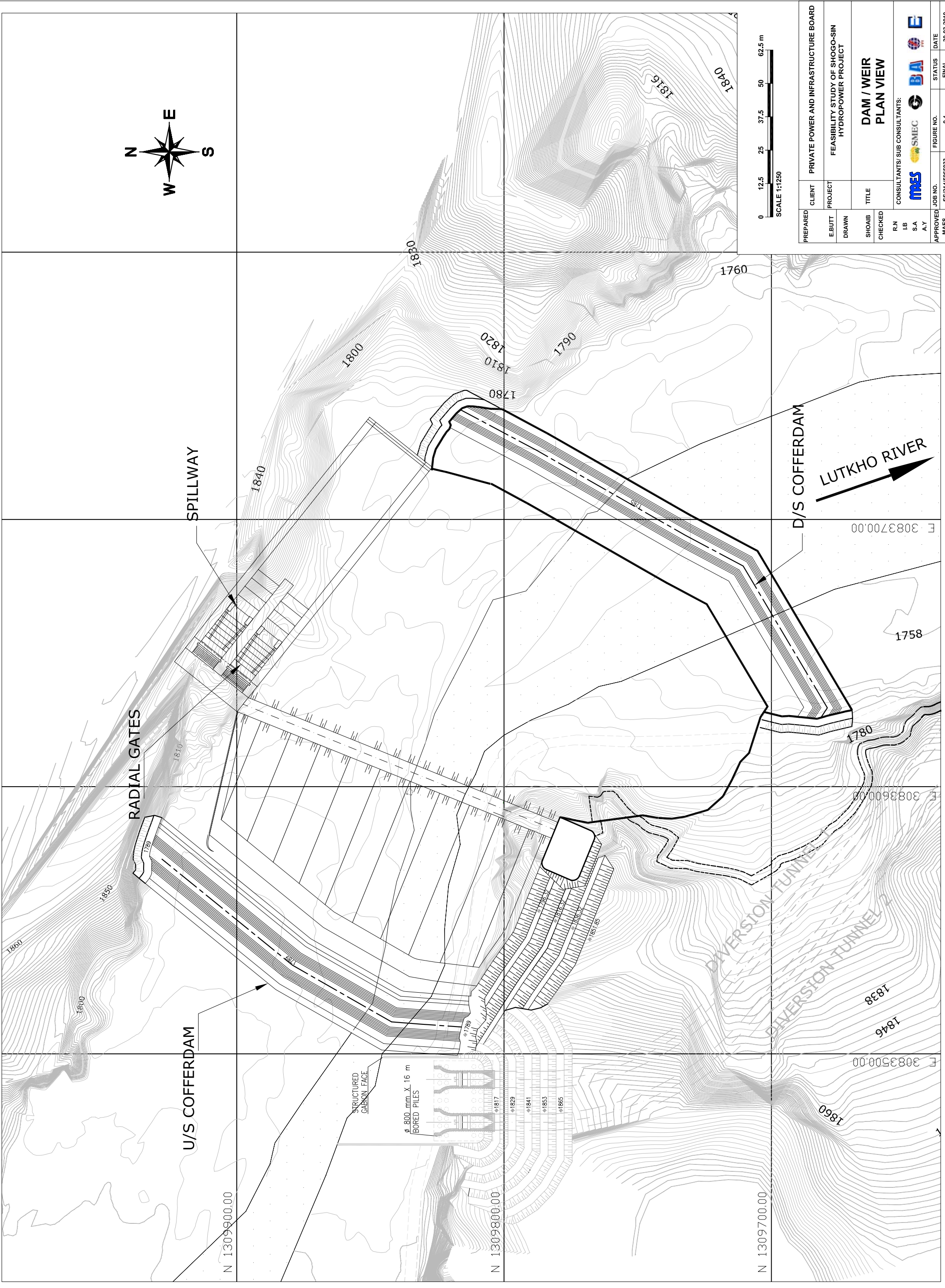

RADIAL GATES

SPILLWAY

U/S COFFERDAM

D/S COFFERDAM

LUTKHO RIVER

STRUCTURED GABION FACE
 ϕ 800 mm X 16 m
 BORED PILES

DIVERSION TUNNEL 1
 DIVERSION TUNNEL 2

N 1309900.00

N 1309800.00

N 1309700.00

E 3083700.00

E 3083600.00

E 3083500.00

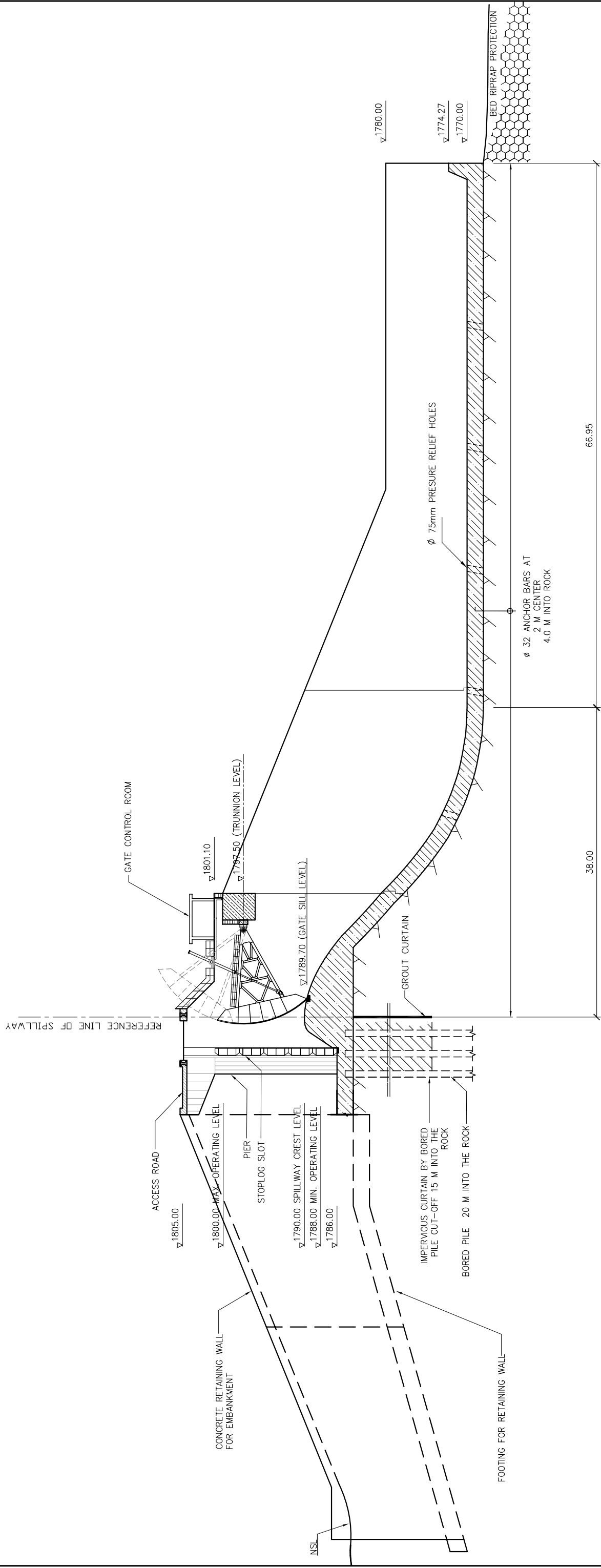

SECTION A-A

(FOR LOCATION OF SECTION A-A SEE DWG: SS-CS-WR-06)

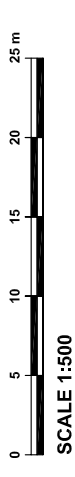

NOTES:

1. ALL LEVELS ARE IN METRES ABOVE SEA LEVEL.
2. ALL DIMENSIONS ARE IN METRES UNLESS INDICATED OTHERWISE.
3. THE SCALES SHOWN ARE FOR A DRAWING PRINTED ON A3 PAPER.

PREPARED	CLIENT	PRIVATE POWER AND INFRASTRUCTURE BOARD
DRAWN	PROJECT	FEASIBILITY STUDY OF SHOHO-SIN HYDROPOWER PROJECT
CHECKED	TITLE	SPILLWAY CROSS SECTION SECTION A-A
R.N	CONSULTANTS/SUB CONSULTANTS:	
I.B	M&S	SMEC
S.A	BA	E
A.Y	JOB NO.	SS/214/06/033
APPROVED	FIGURE NO.	0.5
MAES	STATUS	DRAFT
	DATE	30-03-2010

NOTES:

1. ALL LEVELS ARE IN METRES ABOVE SEA LEVEL.
2. ALL DIMENSIONS ARE IN METRES UNLESS INDICATED OTHERWISE.
3. THE SCALES SHOWN ARE FOR A DRAWING PRINTED ON A3 PAPER.

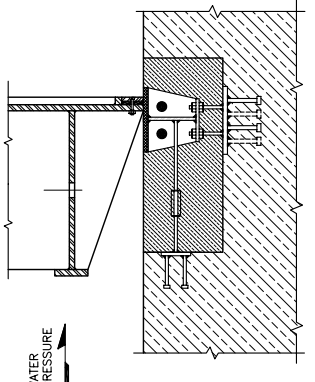
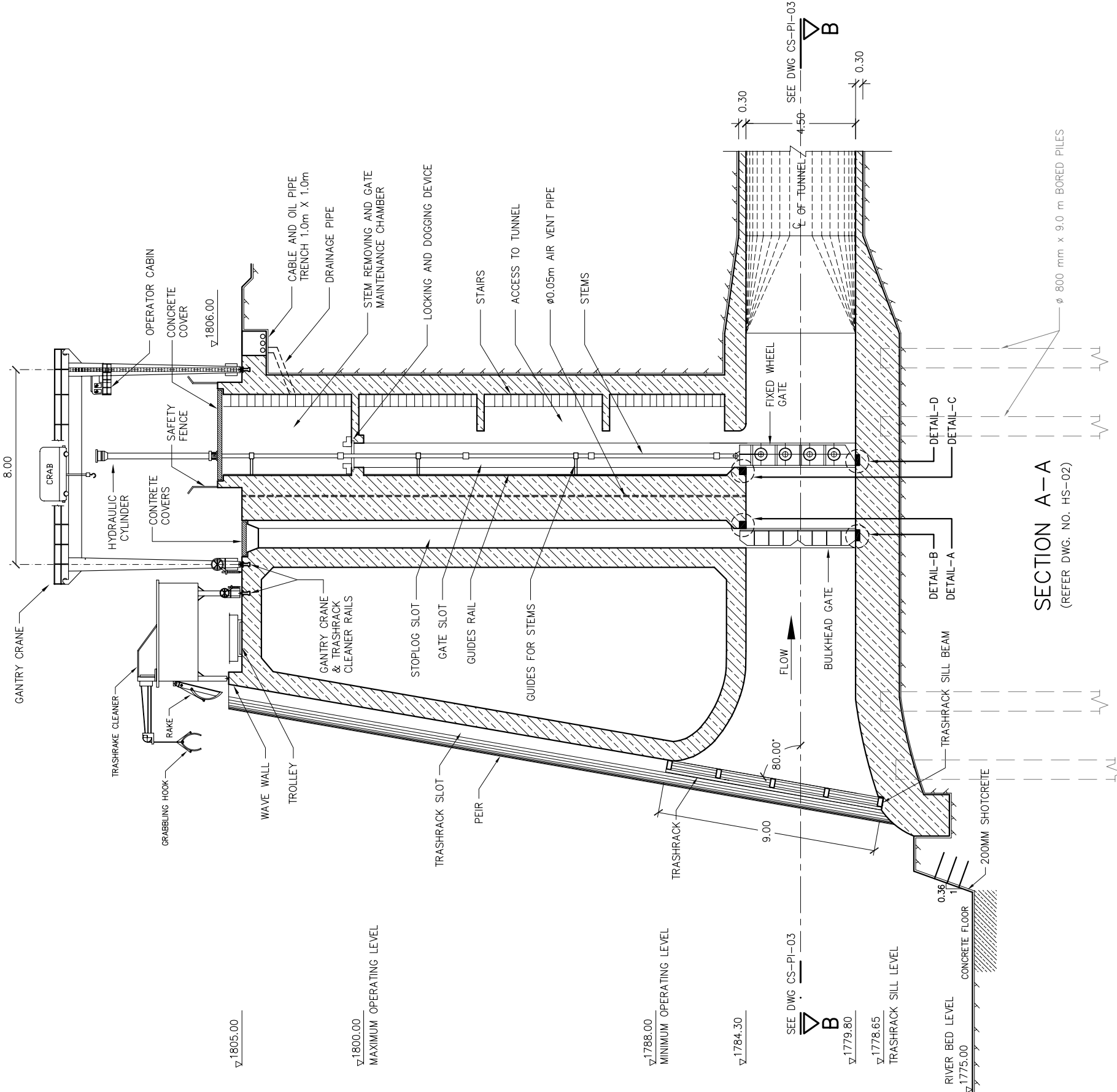

DETAIL - B
BULKHEAD GATE BOTTOM SEAL
SCALE: N.T.S.

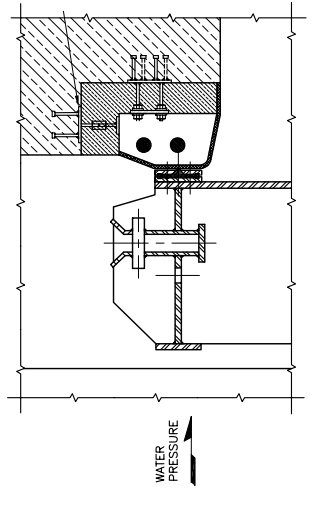

DETAIL - A
BULKHEAD GATE LINTEL SEAL
SCALE: N.T.S.

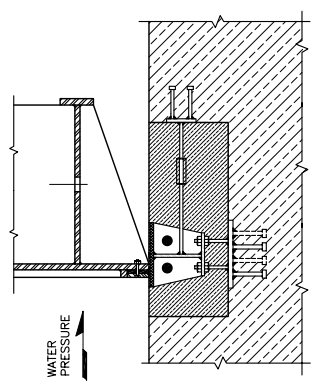

DETAIL - D
FIXED WHEEL GATE BOTTOM SEAL
SCALE: N.T.S.

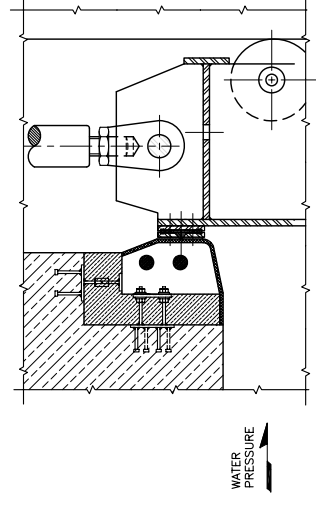

DETAIL - C
FIXED WHEEL GATE LINTEL SEAL
SCALE: N.T.S.

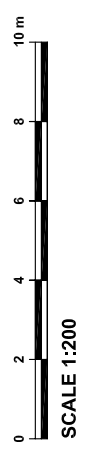

SECTION A-A
(REFER DWG. NO. HS-02)

PREPARED	CLIENT	PRIVATE POWER AND INFRASTRUCTURE BOARD
DRAWN	PROJECT	FEASIBILITY STUDY OF SHOGO-SIN HYDROPOWER PROJECT
CHECKED	TITLE	POWER INTAKE SECTION A-A GATES ARRANGEMENT
R.N	CONSULTANTS/ SUB CONSULTANTS:	
I.B		
S.A		
A.Y		
APPROVED	JOB NO.	SS/214/HS06/033
MAES	FIGURE NO.	0.7
	STATUS	FINAL
	DATE	30-03-2010

NOTES:

1. ALL LEVELS ARE IN METRES ABOVE SEA LEVEL.
2. ALL DIMENSIONS ARE IN METRES UNLESS INDICATED OTHERWISE.
3. THE SCALES SHOWN ARE FOR A DRAWING PRINTED ON A3 PAPER.

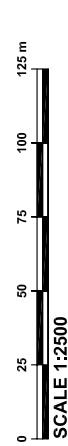
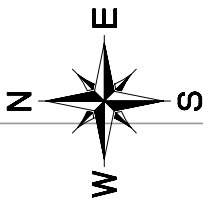

PREPARED	CLIENT	PRIVATE POWER AND INFRASTRUCTURE BOARD
E.BUTT	PROJECT	FEASIBILITY STUDY OF SHOGO-SIN HYDROPOWER PROJECT
DRAWN	TITLE	DESANDER CHAMBER LAYOUT
SHOAB	R.N	CONSULTANTS' SUB CONSULTANTS:
CHECKED	I.B	MES
	S.A	SMEC
	A.Y	BA
		E
APPROVED	JOB NO.	SS214/506503
MAES	FIGURE NO.	0.8
	STATUS	FINAL
	DATE	30-03-2010

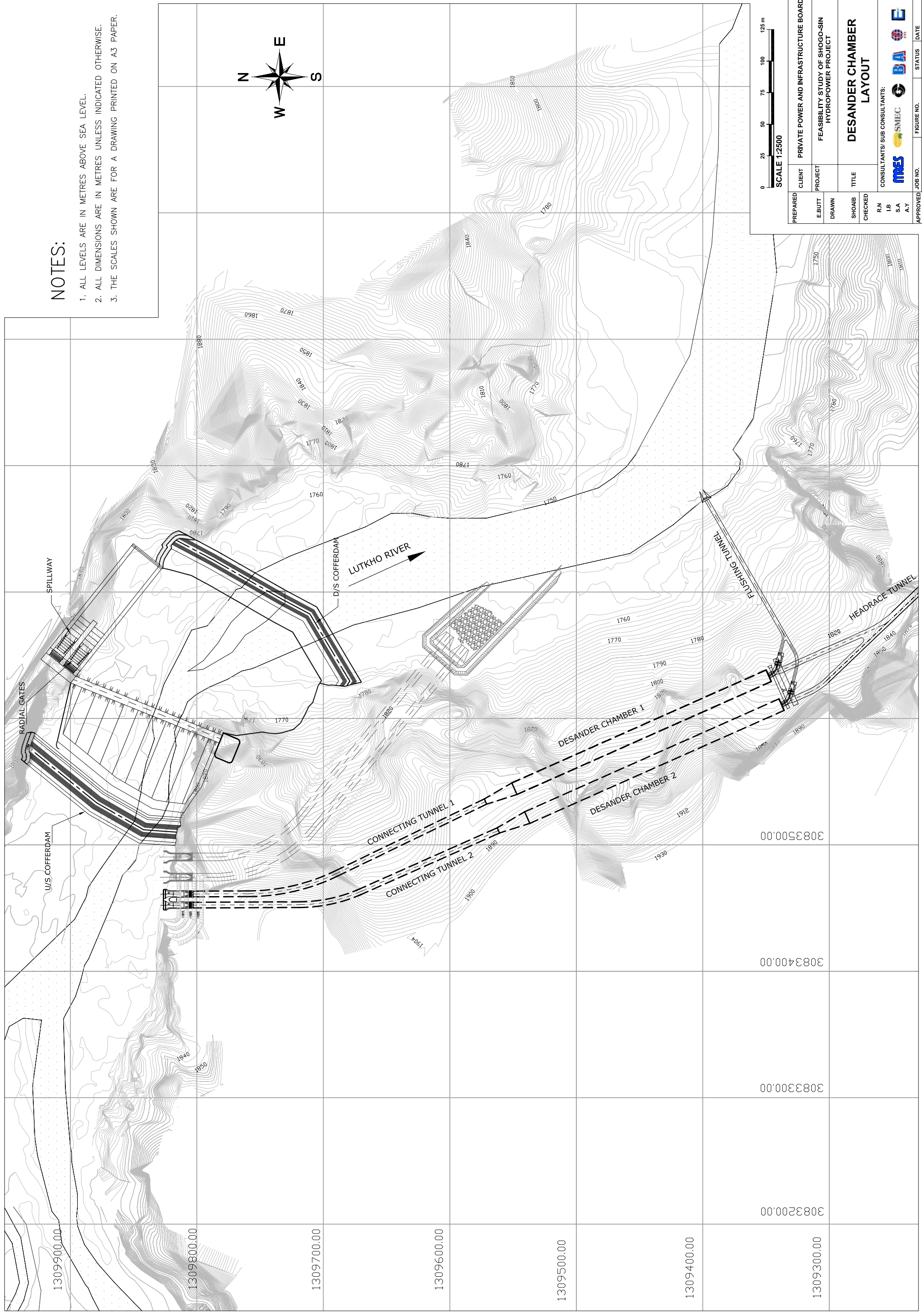

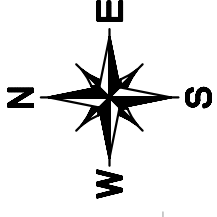

NOTE:

CONTOUR INTERVAL- 2 METER
 GRID INTERVAL- 100 M
 ALL DIMENSIONS ARE IN METERS

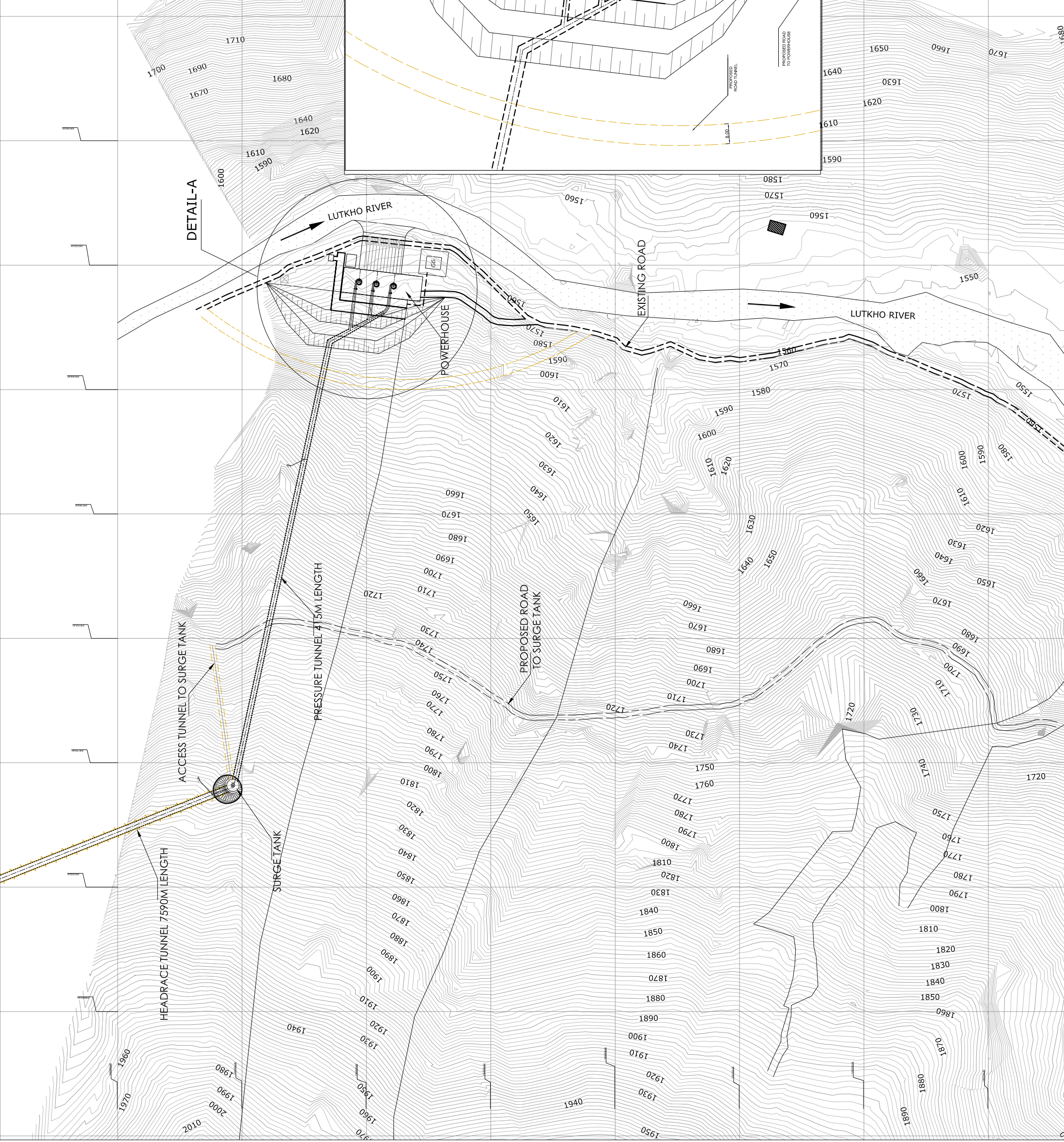

DETAIL-A
 SCALE 1 : 1500

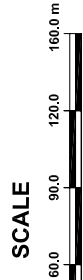
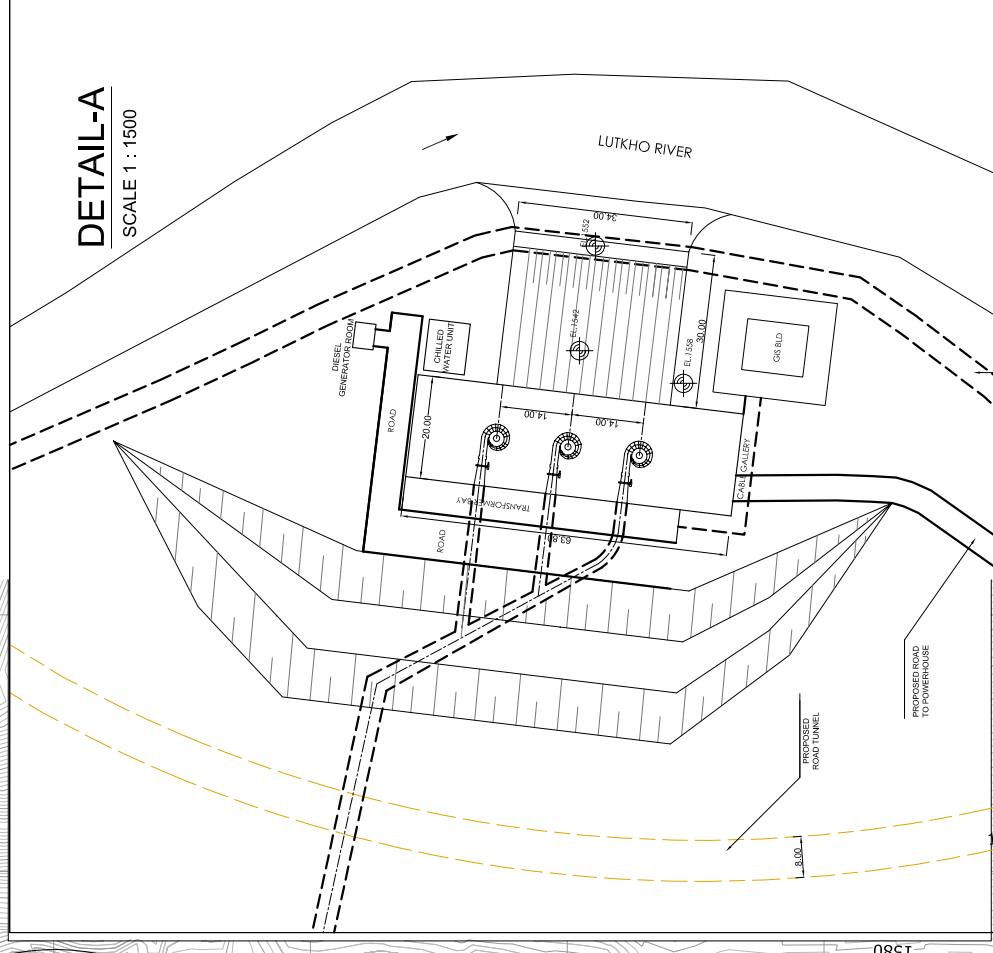

PREPARED	CLIENT	PRIVATE POWER AND INFRASTRUCTURE BOARD
DRAWN	PROJECT	FEASIBILITY STUDY OF SHOGOSIN HYDROPOWER PROJECT
CHECKED	TITLE	PROJECT LAYOUT OF POWERHOUSE AREA
R.N	CONSULTANTS/ SUB CONSULTANTS:	
LB		
S.A	FIGURE NO.	0.9
A.Y	STATUS	FINAL
MAES	APPROVED JOB NO.	SS/214/5065033
	DATE	30-03-2010

TOP OF STEEL FRAME 1572.45

STEEL BEAM

STEEL FRAME

STEEL GIRDER

TOP OF STEEL CORBEL 1563.30

STEEL CORBEL

AUXILIARY HOOK 10 TON

MAIN HOOK 60 TON

TRANSFORMER TRANSFER RAILS

GENERATOR FLOOR 1552.60

132kV XLPE CABLE

MACHINE HALL FLOOR 1557.00

SHAFT

TURBINE

DEWATERING GALLERY

VALVE PEDESTAL

VALVE FLOOR 1544.00

TURBINE FLOOR 1548.60

NOTES:

1. ALL LEVELS ARE IN METRES ABOVE SEA LEVEL.
2. ALL DIMENSIONS ARE IN METRES UNLESS INDICATED OTHERWISE.
3. THE SCALES SHOWN ARE FOR A DRAWING PRINTED ON A3 PAPER.

ROAD WAY

▽ 1557.00 RETAINING WALL LEVEL

▽ 1556.00 MAX TAIL WATER LEVEL

▽ 1551.50 MIN TAIL WATER LEVEL

▽ TURBINE CENTERLINE 1547.00

1545.50

1542.00

1541.50

SCALE



TRANSVERSE SECTION THROUGH UNIT CENTRELINE

PREPARED	CLIENT	PRIVATE POWER AND INFRASTRUCTURE BOARD
DRAWN	PROJECT	FEASIBILITY STUDY OF SHOGOSIN HYDROPOWER PROJECT
CHECKED	TITLE	CROSS SECTION OF POWERHOUSE
R.N	CONSULTANTS/ SUB CONSULTANTS:	
LB		
A.Y		
APPROVED	JOB NO.	FIGURE NO.
MAES	SS/214/5065033	0.10
	STATUS	DATE
	FINAL	30-03-2010

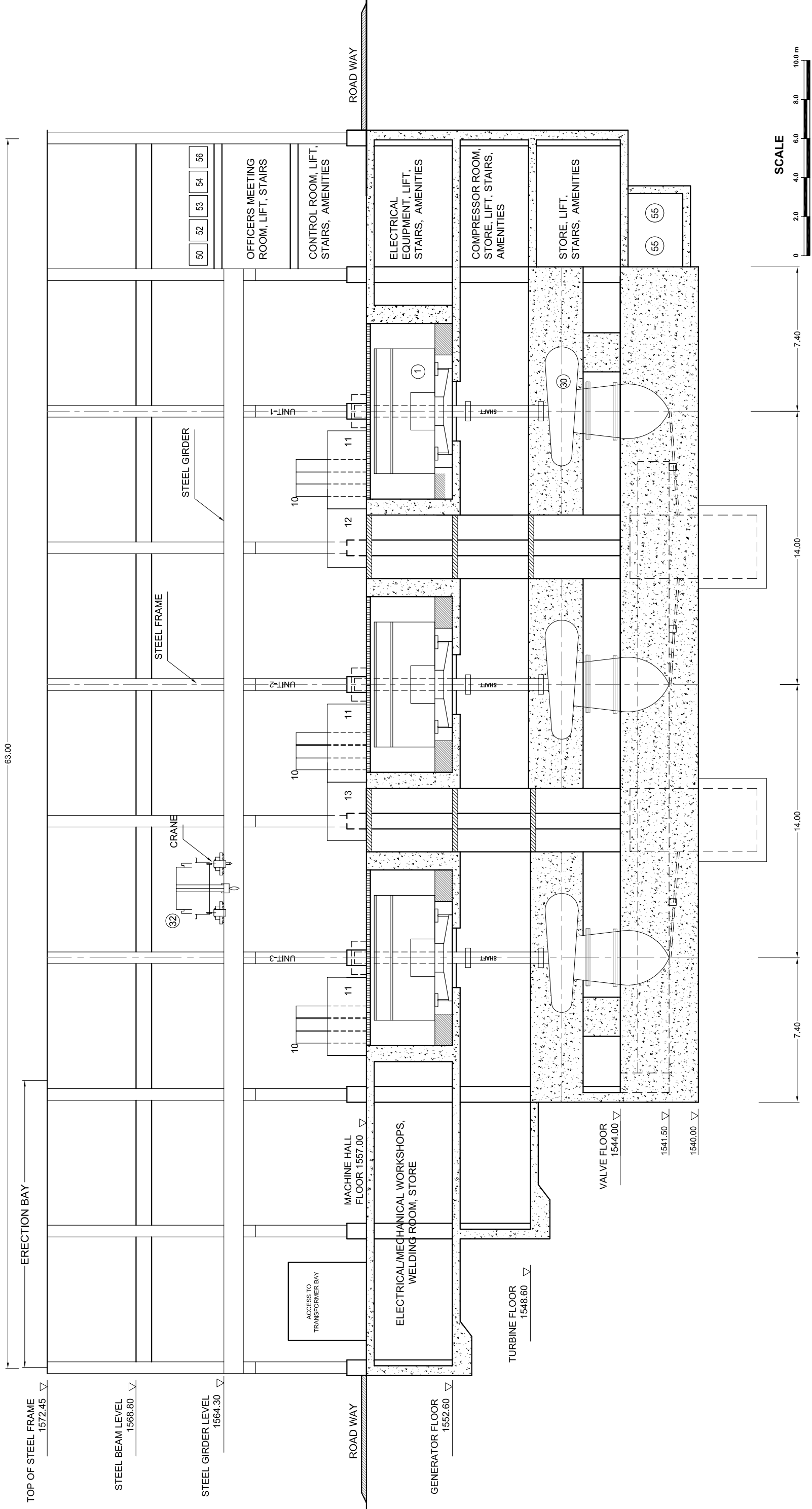

NOTES:

1. ALL LEVELS ARE IN METRES ABOVE SEA LEVEL.
2. ALL DIMENSIONS ARE IN METRES UNLESS INDICATED OTHERWISE.
3. THE SCALES SHOWN ARE FOR A DRAWING PRINTED ON A3 PAPER.

PREPARED	CLIENT	PRIVATE POWER AND INFRASTRUCTURE BOARD
I.BUTT	PROJECT	FEASIBILITY STUDY OF SHOGOSIN HYDROPOWER PROJECT
DRAWN	TITLE	POWERHOUSE LONGITUDINAL SECTION
ZAFAR	CONSULTANTS/ SUB CONSULTANTS:	
CHECKED		
R.N	JOB NO.	SS/214/5065033
LB	FIGURE NO.	0.11
S.A	STATUS	FINAL
A.Y	DATE	30-03-2010
APPROVED	MAES	

