



DEPARTMENT OF THE ARMY
THE INSTITUTE OF HERALDRY
9325 GUNSTON ROAD, ROOM S113
FORT BELVOIR, VIRGINIA 22060-5579

AAMH-IHS

19 November 2018

MEMORANDUM FOR Commander, 36th Quartermaster Detachment, ATTN:
CW2 Michael Kanzler, 748 East McLeroy, Saginaw, TX 76179

SUBJECT: Beret Flash and Background Trimming for the 36th Quartermaster Detachment

1. The request for a beret flash and background trimming is approved and authorized for wear by members of the 36th Quartermaster Detachment.
2. The descriptions of the designs are as follows:

BERET FLASH

A shield-shaped embroidered device with a semi-circular base 2 1/4 inches (5.72 cm) in height by 1 7/8 inches (4.76 cm) in width overall, left half ultramarine blue, the right side divided upper quarter white and lower quarter scarlet. Overall three diagonal stripes from upper right to lower left, each 1/8 inch (.32 cm), light blue over scarlet over green. All edged with a 3/8 inch (.96 cm) buff border.

BACKGROUND TRIMMING

An oval-shaped embroidered device 1 3/8 inches (3.49 cm) in height by 2 1/4 inches (5.72 cm) in width overall, left half ultramarine blue, the right side divided upper quarter white and lower quarter scarlet. Overall three diagonal stripes from upper right to lower left, each 1/8 inch (.32 cm), light blue over scarlet over green. All edged with a 3/8 inch (.96 cm) buff border.

3. Enclosed for use in procurement are:
 - a. Manufacturing drawings (TIOH Dwg No. A-4-323 and TIOH Dwg No. A-6-343).
 - b. Color prints and black and white line drawings.
 - c. A list of certified manufacturers and procedures for local procurement of insignia.
4. This authorization is in accordance with AR 670-1 and does not grant exclusive use of the above colors and pattern design for the 36th Quartermaster Detachment. A copy of this letter will become part of your permanent organizational history files.

AAMHS-IHS

SUBJECT: Beret Flash and Background Trimming for the 36th Quartermaster Detachment

4. Your point of contact for this action is Mr. Garrison at (571) 515-0324 or keith.a.garrison6.civ@mail.mil.

MUGNO.CHARLE MUGNO.CHARLES.V.10207
23374
S.V.1020723374 2018.11.21 11:14:36 -05'00'

Encls

CHARLES V. MUGNO
Director

REVISIONS

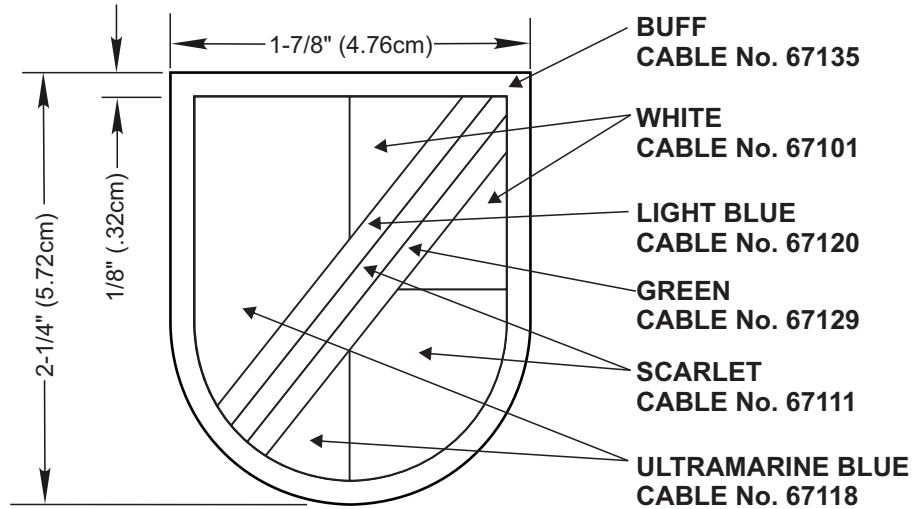

DESIGNED FOR OVEREDGE STITCHING

EXAMINED	<i>TLC</i>		THE INSTITUTE OF HERALDRY, DEPARTMENT OF THE ARMY 9325 GUNSTON RD, RM S-113 FORT BELVOIR, VA 22060-5579
CHECKED	<i>CA</i>	<i>SAO</i>	
PREPARED	<i>AFW</i>		
APPROVED	MUGNO.CHARLE MUGNO.CHARLES.V.10207 S.V.1020723374 23374 2018.11.21 11:14:54 -05'00'		BERET FLASH FOR 36TH QUARTERMASTER DETACHMENT
CHARLES V. MUGNO DIRECTOR			SIZE CONTROL IDENT. NO A 22571
MATERIALS: TO BE MANUFACTURED IN ACCORDANCE WITH MIL-DTL-14652			DATE A-4-323 14 NOVEMBER 2018

REVISIONS

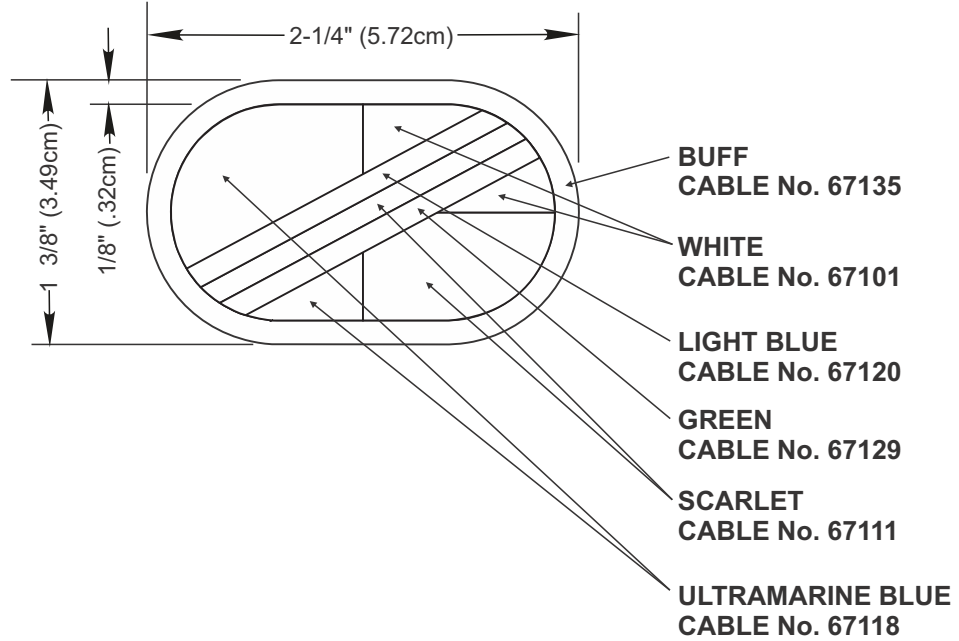

DESIGNED FOR OVEREDGE STITCHING

EXAMINED	<i>TLC</i>	
CHECKED	<i>CA</i>	<i>SAO</i>
PREPARED	AFW	
APPROVED	MUGNO.CHARL MUGNO.CHARLES.V.1020 723374 ES.V.1020723374 2018.11.21 11:15:06 -05'00' <hr/> CHARLES V. MUGNO DIRECTOR	

THE INSTITUTE OF HERALDRY, DEPARTMENT OF THE ARMY 9325 GUNSTON RD, RM S-113 FORT BELVOIR, VA 22060-5579		
BACKGROUND TRIMMING FOR 36TH QUARTERMASTER DETACHMENT		
SIZE A	CONTROL IDENT. NO 22571	A-6-343
SCALE	FULL	DATE 14 NOVEMBER 2018

MATERIALS: TO BE MANUFACTURED IN ACCORDANCE WITH MIL-DTL-14652

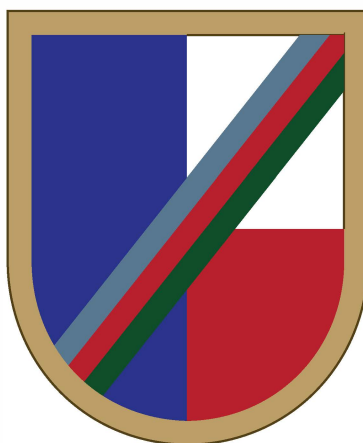

FLASH

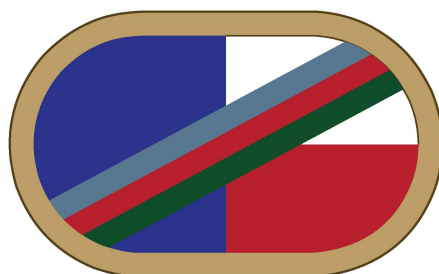

TRIM

*FLASH and TRIM
36TH QUARTERMASTER
DETACHMENT*

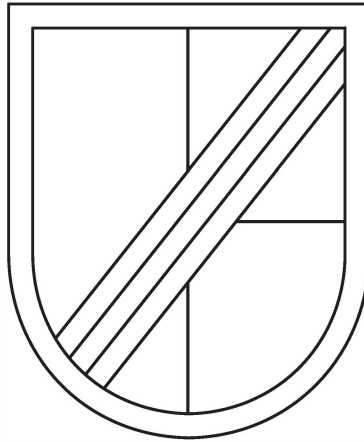

FLASH

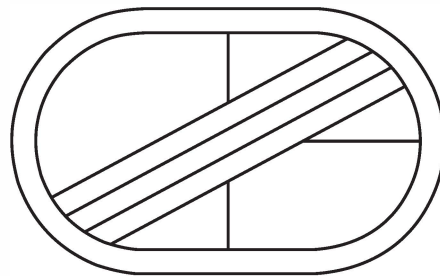

TRIM

*FLASH and TRIM
36TH QUARTERMASTER
DETACHMENT*



LOCAL PROCUREMENT PROCEDURES OF INSIGNIA

--

1. Authorization for local procurement of insignia as specified in paragraph 3 below is contained in AR 710-2 and AR 670-1. Distinctive Unit Insignia (DUI) and regimental collar insignia (RCI) are locally procured. In addition, authorized shoulder sleeve insignia (SSI) may be locally procured until it is centrally procured and stocked through the Soldier Systems Directorate, Philadelphia. After shoulder sleeve insignia has been stocked by Philadelphia, local purchase is unauthorized.

2. After an insignia item has been approved by The Institute of Heraldry (TIOH), one of the following actions will be taken based upon the type of funds used for procurement:

a. Use of Appropriated Funds. Requisitions will be submitted through supply channels and purchased by local command servicing procurement officers for Active Army and Army Reserve units and by the USP&FO for Army National Guard units. A purchase request for local procurement will be prepared and submitted to the contracting officer in accordance with local procedures. The contracting officer will provide the manufacturer with the official manufacturing drawing for bidding purposes. Upon obtaining an acceptable bid, the contracting officer will advise the selected manufacturer to contact TIOH for loan of government tools to be used in manufacturing metal insignia items. A drawing is not required for RCI.

b. Use of Nonappropriated Funds. AR 670-1 permits use of nonappropriated funds (Unit Fund) for purchase of DUI when appropriated funds are not available. Unit funds may not be used to purchase SSI or RCI. A manufacturer must be selected from the list of manufacturers certified by TIOH for unit fund and other types of nonappropriated purchases, such as group purchases.

3. All insignia must be manufactured by firms certified by TIOH in accordance with AR 672-8. Procurement of insignia from non-certified manufacturers or from foreign or offshore sources is not authorized. Manufacturers who are interested in becoming certified manufacturers will be referred to the Director, The Institute of Heraldry for certification. All invitations for bids or contracts should include a statement that the insignia will be made in accordance with the specifications and tools provided by TIOH.

a. Distinctive Unit and Regimental Collar Insignia. DUI and regimental collar insignia must have the hallmark of the manufacturer stamped on the reverse. In addition, all DUI must have "Made in USA" stamped on the reverse. DUI will be manufactured in accordance with MIL-I-14654(IH). Regimental collar insignia will be

LOCAL PROCUREMENT PROCEDURES OF INSIGNIA

--

manufactured in accordance with MIL-I-3575 for officers and MIL-I-15665 for enlisted personnel. Purchase request for DUI should include unit designation and the motto contained on the DUI, if applicable. Requests for regimental collar insignia or DUI should include unit designation and the motto contained on the DUI, if applicable. Requests for regimental collar insignia should include the name of the branch and the regimental number. Note: The battalion numerical designation will not be placed on Infantry, Armor, Cavalry, Field Artillery, Air Defense Artillery or Aviation regimental collar insignia. Hubs and/or dies will be loaned to the contractor by TIOH.

b. Shoulder Sleeve Insignia. Shoulder sleeve insignia will be manufactured in accordance with MIL-I-14652. The contractor will be advised that a "cartoon" (pattern) showing the placement and the number of stitches for the SSI may be obtained from TIOH.

c. ROTC Shoulder Loop Insignia. Solicitations for ROTC shoulder loop insignia should indicate that the insignia will be manufactured in accordance with MIL-I-14654(IH) and the contractor will be responsible for making any hubs and dies necessary for manufacturing. The design will be in accordance with the TIOH approved drawing.

d. Beret Flashes, Background Trimmings and ROTC Institutional SSI. The solicitation should indicate the insignia will be manufactured in accordance with MIL-I-14652 from the approved TIOH drawing. A "cartoon" (pattern) is not provided for these items.

4. The manufacturer is required to submit preproduction samples of all insignia to TIOH regardless of whether appropriated or nonappropriated funds are used for procurement. Once samples are approved, TIOH will issue a letter to the manufacturer authorizing manufacture of the insignia item. National Guard regulations currently require that a copy of the letter be forwarded by the manufacturer to the USP&FO prior to completion of the order. This procedure is recommended for inclusion in contracts by Regular Army and US Army Reserve procurement officers to insure that samples have been approved by TIOH.

ACTIVE LIST OF CERTIFIED MANUFACTURERS (MASTER LIST) 11/14/2018
 THE INSTITUTE OF HERALDRY, 9325 GUNSTON ROAD, ROOM S113, FORT BELVOIR, VIRGINIA 22060-5579
 COMM 703-806-4984 DSN 656-4984

NAME	STREET	LOCATION	HMK	MANUF	TELEPHONE	FAX_NO
A-B EMBLEMS/CONRAD	291 MERRIMON AVENUE	WEAVERVILLE, NC 28787	A35	1	828-645-3015	828-658-3581
ACTION EMBROIDERY CORP	1315 WEST BROOKS ST	ONTARIO, CA 91762	A25	1	800-638-7223	909-983-2755
AWARD CRAFTERS, INC	14110 SULLYFIELD CIRCLE	CHANTILLY, VA 20151	A37	4	703-818-0500	703-818-0500
BALDWIN RIBBON & STAMPING	39-56 63RD STREET	WOODSIDE, NY 11377	B31	2	888-335-6900	718-478-3449
BALLY RIBBON MILLS	23 NORTH SEVENTH ST	BALLY, PA 19503	B22	1d	610-845-2211	610-845-8013
BENDE & SONS, INC	180 AUTUMN ST	PASSAIC, NJ 07055	B26	1d	973-777-8700	973-777-7715
CLASSIC MEDALLICS, INC.	520 SOUTH FULTON AVE.	MT. VERNON, NY 10550-5083	C31	2	914-530-6259	914-662-5001
CREST CRAFT						
DISCOVERY MARKETING & DESIGN	90 MIDDLE STREET	PAWTUCKET, RI 02860	D29	2	401-725-1404	401-723-2602
DONDERO, INC	P.O BOX 59	BROWNSBURG, VA 24415	D21	2/3/4	540-348-6753	540-348-6293
EISEMAN-LUDMAR CO, INC	56 BETHPAGE DRIVE	HICKSVILLE, NY 11801	E31	3	516-932-6330	516-932-3304
EMPIRE STATE METAL PRODUCTS						
ERFFMEYER & SON CO, INC	5300 W. CLINTON AVE	MILWAUKEE, WI 53223	E27	2	414-354-7800	414-362-7287
GREAT AMERICAN WEAVING CORP	20 NORTH FRONT STREET	BALLY, PA 19503	G31	1d	610-845-9200	610-845-7147
HALLMARK EMBLEMS INC	2401 TAMPA STREET	TAMPA, FL 33602	H27	1	800-237-2567	813-273-0564
INTERNATIONAL INSIGNIA CORP	1280 EDDY STREET	PROVIDENCE, RI 02905	I21	2	401-784-0000	401-941-8400
IRA GREEN, INC	177 GEORGIA AVE	PROVIDENCE, RI 02905	G23	2/5	800-663-7487	800-738-8522
KENNEDY INC	21 CIRCUIT DRIVE	NORTH KINGSTOWN, RI 02852	K28	2	401-295-7800	401-295-4844
MASTERCRAFT AWARDS GENERAL	10390 CENTRAL PARK DRIVE	MANASSAS, VA 20110	G25	4	703-335-9292	866-692-5097
MEDALCRAFT MINT, INC	2660 WEST MASON STREET	GREEN BAY, WI 54303	M33	2	920-593-1531	800-558-6348
MIL-BAR PLASTICS INC						
OFFICER'S EQUIPMENT COMPANY	3935 JEFFERSON DAVIS HIGHWAY	STAFFORD, VA 22554	O22	2/5	800-221-1915	703-221-4115
RAINBOW EMBROIDERY	305 3rd AVE WEST	NEWARK, NJ 07107	R27	1	976-368-2020	
RELIABLE WORLD TRADE CO, INC.	9849 KITTY LANE	OAKLAND, CA 94603	R30	1c	510-614-2277	510-614-7175
SAYRE ENTERPRISES	324 EAST 32ND STREET	BUENA VISTA, VA 24416	S44	1	540-261-1546	540-261-1507
SCHREYER EMBROIDERY CO	50 INDUSTRIAL DR	FAIRVIEW, NJ 07022	S33	1	201-943-6221	201-943-0827
SMART DESIGN INC.	833 HIGHAMS COURT	WOODBIDGE, VA 22191	S51	4	703-492-2764	703-492-4865
SMITH AND WARREN	127 OAKLEY AVENUE	WHITE PLAINS, NY	S50	2	914-948-4619	914-948-1627
SUPERIOR DIE & STAMPING INC						
THE SUPPLY ROOM	230 SUPPLYROOM RD	OXFORD, AL 36203	S38	2	800-458-5180	800-521-5027

CODES USED TO INDICATE TYPE OF MANUFACTURER

1 TEXTILE ALL (1a-SSI; 1b-Badges; 1c-Rank; 1d-Ribbon; 1e-Tapes). 2 METAL ALL (2a-Badges; 2b-Medals; 2c-Lapel Buttons; 2d-Medallions; 2e-Rank/Branch Insignia; 2f-DUI). 3 HAND EMBROIDERED BULLION. 4 PLAQUES. 5 AAFES/NEX/MCX VENDOR

ACTIVE LIST OF CERTIFIED MANUFACTURERS (MASTER LIST) 11/14/2018
 THE INSTITUTE OF HERALDRY, 9325 GUNSTON ROAD, ROOM S113, FORT BELVOIR, VIRGINIA 22060-5579
 COMM 703-806-4984 DSN 656-4984

UNIVERSAL SPECIALTY AWARDS	1205 WESTMINSTER STREET	PROVIDENCE, RI 02909	U23	2	401-727-0083	401-727-4592
URSCHTEL TOOL COMPANY	43 NAVAHO ST	CRANSTON, RI 02907	U21	2	401-944-0600	401-946-4430
USA INSIGNIA-SWEET MASS PROD	28 JOHN WILLIAMS ST	ATTLEBORO, MA 02703	U24	2	508-386-1913	
VANGUARD INDUSTRIES EAST	1172 AZALEA GARDEN RD	NORFOLK, VA 23502	V21	5	800-221-1264	757-857-0222
VANGUARD INDUSTRIES WEST	2440 IMPALA DRIVE	CARLSBAD, CA 92008	V21	5	800-433-1334	760-438-7803
V.H. BLACKINGTON & COMPANY						

CODES USED TO INDICATE TYPE OF MANUFACTURER

- 1 TEXTILE ALL (1a-SSI; 1b-Badges; 1c-Rank; 1d-Ribbon; 1e-Tapes). 2 METAL ALL (2a-Badges; 2b-Medals; 2c-Lapel Buttons; 2d-Medallions; 2e-Rank/Branch Insignia; 2f-DUI). 3 HAND EMBROIDERED BULLION. 4 PLAQUES. 5 AAFES/NEX/MCX VENDOR