

DOT/FAA/AR-97/26

Office of Aviation Research
Washington, D.C. 20591

Impact of New Large Aircraft on Airport Design

March 1998

Final Report

This document is available to the U.S. public
through the National Technical Information
Service (NTIS), Springfield, Virginia 22161.



U.S. Department of Transportation
Federal Aviation Administration

NOTICE

This document is disseminated under the sponsorship of the U.S. Department of Transportation in the interest of information exchange. The United States Government assumes no liability for the contents or use thereof. The United States Government does not endorse products or manufacturers. Trade or manufacturer's names appear herein solely because they are considered essential to the objective of this report.

1. Report No. DOT/FAA/AR-97/26		2. Government Accession No.		3. Recipient's Catalog No.	
4. Title and Subtitle IMPACT OF NEW LARGE AIRCRAFT ON AIRPORT DESIGN				5. Report Date March 1998	
				6. Performing Organization Code	
7. Author(s) James W. Patterson				8. Performing Organization Report No.	
9. Performing Organization Name and Address Galaxy Scientific Corporation 2500 English Creek Avenue Egg Harbor Twp., NJ 08234				10. Work Unit No. (TRAIS)	
				11. Contract or Grant No. DTFA03-95-D-00019	
12. Sponsoring Agency Name and Address U.S. Department of Transportation Federal Aviation Administration Office of Aviation Research Washington, DC 20591				13. Type of Report and Period Covered Final Report	
				14. Sponsoring Agency Code AAR-410	
15. Supplementary Notes FAA William J. Hughes Technical Monitor: Satish Agrawal					
16. Abstract <p>The object of this project is to assess the impact of the introduction of proposed new large aircraft (NLA) on current airport design standards and administered by the Federal Aviation Administration (FAA).</p> <p>This report identifies several key design and operational characteristics of proposed NLA that will need to be taken into consideration before the aircraft are introduced into the current airport environment. Specific elements of airport planning and design that may be affected by these changes in aircraft characteristics have been identified to assist airport planners and the FAA in preparing for the NLA's arrival. In addition, a 20-year projection of NLA development and a qualitative cost and compatibility assessment of introducing NLA's at a sample airport that currently serves the Boeing 747 are included in this final report.</p> <p>Throughout this report, references are made to current airport design Advisory Circulars that will require modifications to reflect the introduction of NLA. Some changes will include simple additions of aircraft performance data, while others will require incorporation of new standards or recommendations that specifically address NLA. Airports expecting to serve NLA will be required to modify their existing facilities to meet the design criteria of airport design group VI.</p> <p>Recommendations are made to revise the applicable airport design standards, continue investigating the demands of NLA, and to determine their affects on the individual airports that are expecting to serve them.</p>					
17. Key Words New large aircraft Airport design standards			18. Distribution Statement This document is available to the public through the National Technical Information Service (NTIS), Springfield, Virginia 22161.		
19. Security Classif. (of this report) Unclassified		20. Security Classif. (of this page) Unclassified		21. No. of Pages 85	22. Price

TABLE OF CONTENTS

	Page
EXECUTIVE SUMMARY	vii
INTRODUCTION	1
Purpose	1
Background	1
NEW LARGE AIRCRAFT CHARACTERISTICS	1
Discussion	1
The Future Development of NLA	4
AIRPORT DESIGN RATIONALE	9
IMPACT ON AIRPORT DESIGN	10
Airside Impact—Geometrical Design of Runways and Taxiways	10
Runway Design	11
Taxiway Design	16
Taxiway Separation Standards	19
Taxiway Holding Bays and Bypass Taxiways	22
Runway and Taxiway Bridges	22
Runway and Taxiway Culverts	23
Airside Impact—Airport Pavement Design	23
Airside Impact—Safety Issues	24
Fire Protection and Equipment	25
Emergency Procedures	27
Training Facilities	28
Deicing Facilities	29
Deicing Operations	30
Engine Clearances Over Obstructions	30
Airside Impact—Environmental Issues	32
Airport Noise	32
Air Quality	33
Water Runoff	33

Landside Impact	33
Gate Requirements	33
Gate Type Determination	34
Apron Separation Clearances	34
Passenger Loading Bridges	35
Ground Servicing	36
Landside Impact—Terminal Design	36
Ticketing Lobbies	36
Waiting Lobbies	37
Baggage Lobbies	37
Public Corridors	37
Security Inspection Stations	37
Departure Lounges	38
Parking Facilities	38
Landside Issues—Baggage Handling	39
COSTS FOR INTRODUCING NEW LARGE AIRCRAFT	39
CONCLUSIONS	42
RECOMMENDATIONS	43
REFERENCES	44
APPENDIX A—Aircraft Data Sheets and Airport Design Criteria Data Sheets	

LIST OF FIGURES

Figure		Page
1	Typical Aircraft Development Program	5
2	Maximum Takeoff Weight Trends	6
3	Aircraft Wingspan Trends	7
4	Aircraft Length and Height Trends	8
5	Aircraft Wheelbase Trends	8
6	NLA Runway Length Requirements	12
7	Runway Width Versus New Large Aircraft	13
8	Projection of Affected NLA Jet Blast Area	14
9	NLA on Typical Design Group VI Taxiway	17
10	Determination of Taxiway Edge Safety Margin During Judgmental Oversteering	19
11	Depiction of NLA on Design Group V and VI Parallel Taxiway	21
12	NLA on Single Taxilane	22
13	NLA on Dual Taxilane	22
14	Aircraft Deicing Pad	30
15	NLA Sign Clearance	31
16	Snow Removal Requirements—AC 150/5200-30A	32
17	Terminal Apron Design Standards	35

LIST OF TABLES

Table		Page
1	Airport Reference Code (ARC) Determination	9
2	NLA ARC Determination	10
3	NLA Runway Length Requirements	11
4	Runway Blast Pad Design Standards	15
5	Taxiway Design Requirements	16
6	Runway and Taxiway Separation Standards for Approach Category C and D Aircraft	20
7	New Large Aircraft Gear Configuration	24
8	ARFF Index Determination	25
9	Departure Lounge Area Space Requirements	38
10	Airports Currently Serving the Boeing 747	41

EXECUTIVE SUMMARY

Over the last few years, airlines and aircraft manufacturers have been discussing the future requirement for a new, larger aircraft capable of carrying between 500 and 1,000 passengers that, as a result, will weigh in excess of 1 million pounds. Deliveries of these types of aircraft are expected to begin in 5 to 10 years.

The purpose of this research study is to assess how the proposed new large aircraft (NLA) will affect the current airport planning and design standards issued by the Federal Aviation Administration (FAA).

The study was divided into three major areas: New Large Aircraft Characteristics, Impact on Airport Design, and Costs to Airports for Introducing New Large Aircraft. For simplification, each of these areas is discussed individually. The design characteristics of civil transport aircraft have historically followed trends that produce aircraft with larger weight capacities and longer wingspan, length, height, and wheelbase values. By analyzing the past evolution of aircraft design characteristics, we can postulate the direction in which NLA design features will travel. While it is impossible to know exactly what will happen with the design of aircraft 20 years into the future, it is possible to predict reliably the key dimensions such as weight, wingspan, fuselage length, tail height, and wheelbase.

This report identifies several key design and operational characteristics of the proposed NLA that will need to be taken into consideration before the aircraft are introduced into the current airport environment. Specific elements of airport planning and design that may be affected by these changes in aircraft characteristics have been identified to assist airport planners and the FAA in preparing for the NLA's arrival. In addition, a 20-year projection of NLA development and a qualitative cost and compatibility assessment of introducing NLA to a sample airport that currently serves the Boeing 747 are included in this report.

Throughout this report, references are made to current airport design Advisory Circulars (AC) that will require modifications to reflect the introduction of NLA. Some changes will include simple additions of aircraft performance data, while others will require incorporation of new standards or recommendations that specifically address NLA.

Airports expecting to serve NLA will generally be required to modify their existing facilities to meet the design criteria of airport reference code D-VI. This will involve millions of dollars in improvement costs and may prevent many airports from attempting to serve NLA. Without these modifications, domestic airports may be forced to operate under FAA issued waivers and this may reduce the system capacity.

Recommendations are made to revise the applicable Advisory Circulars and continue investigating the demands of NLA and to determine their affects on the individual airports that are expecting to serve them. Solutions should be provided to the airports in a timely manner to allow implementation of the changes before the introduction of the NLA.

INTRODUCTION

PURPOSE.

The purpose of this research effort is to predict the impact of the introduction of new large aircraft (NLA) on the airport environment and on the corresponding Federal Aviation Administration's (FAA) Advisory Circulars covering airport design.

This report identifies several key design and operational characteristics of proposed NLA that will need to be taken into consideration before such aircraft are introduced into the current airport environment. Specific elements of airport planning and design that may be affected by these changes in aircraft characteristics have been identified to assist airport planners and the FAA in preparing for the NLA's arrival. In addition, a 20-year projection of NLA development and a qualitative cost and compatibility assessment of introducing NLA to a sample airport that currently serves the Boeing 747 are included in this report.

BACKGROUND.

Thirty years ago, when the Boeing Aircraft Corporation first introduced the 747, the FAA upgraded its standards and guidance material to accommodate the larger than the typical aircraft. Numerous terminal, runway, taxiway, and pavement design criteria were carefully reviewed to identify problems or conflicts that would be created with the introduction of the jumbo jet. Today, with the recent introduction of the Boeing 777, the need for similar updates and revisions should be investigated.

As might be expected, new large aircraft will be significantly greater in length, width, and height. In fact, every dimension of the new large aircraft will be greater than those of current aircraft. Existing Advisory Circulars (AC's) mention the certainty of larger aircraft being introduced in the future but do not describe the changes that will be required to accommodate these NLA. This report identifies each element of NLA design that may be incompatible with existing airport design and also cites specific areas wherein revisions to existing design standards may have to be made to accommodate the new aircraft.

NEW LARGE AIRCRAFT CHARACTERISTICS

DISCUSSION.

Development of new large aircraft is being explored by Boeing, McDonnell Douglas, and Airbus Industries. Each plan to develop its own family of "super-jumbo" jets. Many of the planned aircraft are larger derivatives of aircraft that are already flying. Other new aircraft, however, are based on completely new designs that are unlike anything currently in production.

Announced specifications have undergone continuous alteration with changes ranging from simple size adjustments to dramatic redesign of the entire aircraft. Some aircraft that were originally planned as a double-deck design have been scaled down to traditional single-deck

configurations. Confirming actual design data on NLA from the manufacturers has been difficult due to the complexity and fluidity of the design process. Every effort has been taken, however, to obtain the most accurate, up-to-date information. It is most likely that the aircraft's design will change again several times before they go into final production.

One NLA project titled the "Very Large Civil Transport" (VLCT), which was proposed as a cooperative effort between several aircraft manufacturers, is no longer under consideration. The concept was to develop an 800-plus passenger aircraft designed and constructed by a worldwide consortium of aircraft manufacturers.

The following briefly describes the new large aircraft models that, at the time this report was written, are planned for development by each of the three major aircraft manufacturers. Information on two large aircraft that are already in production, the Boeing 747-400 and 777-200, has also been provided for comparison purposes. In addition to the general description of the aircraft, key dimensions that are of particular interest are also provided. Complete data sheets for all aircraft mentioned in this section can be found in appendix A.

- Boeing Airplane Corporation
 - B777-200 B-market—The Boeing 777-200 B-market is a structurally enhanced version of the currently produced 777-200, available from the manufacturer with a high gross weight option. Physically, it looks exactly like a typical 777-200. It can, however, carry approximately 80,000 pounds more than its counterpart. Though this aircraft is not considered a NLA, its heavier weight and landing gear design could be a challenge for future airport design. For simplification, this model of aircraft will be referred to as the 777-200B throughout this report.
 - B777-300—The Boeing 777-300 is a stretched version of the typical B777-200, scheduled for introduction in early 1997. This 420 passenger twin-engine aircraft will have a maximum takeoff weight (MTOW) of approximately 660,000 pounds and will be 242 feet long (11 feet longer than the B747-400).
 - B747-600X—The Boeing 747-600X is a larger derivative of the B747-400, scheduled for introduction in late 2000. The 600X will have a redesigned wing, increased engine size, 20-wheel main gear, 4-wheel nose gear, and a fuselage stretch of 47 feet. The airplane will have a significantly increased weight capacity, a longer range, be capable of carrying 548 passengers, and have a MTOW of 1.2 million pounds.
 - B747-500X—The Boeing 747-500X is also a larger derivative of the B747-400, scheduled for delivery in late 2001. Physically, it is a shorter version of the 600X. The 500X will feature all of the modifications comprising the 600X but will have a 28-foot shorter fuselage. Its reduced size will enable it to fly over 1,000 nautical miles farther than the 600X while carrying a payload comparable to that of the 400. The 500X will also have a MTOW in excess of 1 million pounds.

- High-Speed Civil Transport (HSCT)—The Boeing HSCT is a supersonic aircraft designed to carry 250-300 passengers over 5,000 nautical miles at speeds of Mach 2.0 to 2.5. The fuselage of the aircraft will be 326 feet long, with a wingspan of 155 feet. Boeing’s development of the HSCT is being conducted under contract for NASA and in cooperation with the former McDonnell Douglas. Because of the complexity in developing a supersonic aircraft, all three organizations are working together to solve technological problems and to determine the feasibility of the aircraft. Once the HSCT is developed, both Boeing and McDonnell Douglas will market their own derivatives to the airline market. Boeing’s version of the aircraft is expected to be introduced into service sometime between the years 2005 and 2015.

- McDonnell Douglas Corporation
 - MD-XX—The MD-XX is a newly proposed derivative of the MD-11. Preliminary MD-XX design features include a 31-foot stretched fuselage, redesigned wing, three post main landing gear, and three higher thrust engines. Aside from the stretched fuselage, the operational and physical dimensions of the aircraft will be comparable to those of the MD-11. Passenger capacity will increase by 25 percent, up to 360 passengers. The MD-XX replaces the double-deck MD-12X that was under consideration by McDonnell Douglas.
 - MD-XX LR (Long Range)—The MD-XX LR is a proposed derivative of the baseline MD-XX that will include many of the improved modifications of the MD-XX, with a reduction in the fuselage length to 204 feet. The wingspan will remain the same for the LR version. The MD-XX LR program is still under study by McDonnell Douglas and has not yet been scheduled for launch.
 - High-Speed Civil Transport (HSCT)—The McDonnell Douglas HSCT, like the Boeing version, will be a supersonic transport capable of carrying approximately 300 passengers. The aircraft, as it is presently configured, will be 334 feet long, have a wingspan of 128 feet, and weigh 753,000 pounds at MTOW. The McDonnell Douglas HSCT is tentatively scheduled for delivery sometime between the years 2005 and 2015. Development of the aircraft will of course depend heavily on the research and development of advanced supersonic technology.

- Airbus Industries
 - A3XX-100—The Airbus A3XX-100 is an entirely new aircraft that is scheduled to be introduced into service by 2003. The A3XX-100, unlike other currently planned aircraft, will feature a double-deck design capable of holding 555 passengers and 187,000 pounds of cargo when full. The aircraft will be 232 feet long, 79 feet tall, and have a 259-foot wingspan. MTOW will be approximately 1.1 million pounds, supported by a four-strut, 24-wheel main landing gear. A

final decision on the aircraft design is expected to occur sometime toward the end of 1998. It is anticipated that the aircraft's basic shape and size will not change, but changes in its operational characteristics may occur. Engine selection, wing design, and other modifications may result in operating weight changes but should not affect the general size of the aircraft.

- A3XX-200—The Airbus A3XX-200 is a stretched derivative of the A3XX-100 that is being considered for production after the 100 is introduced. The aircraft will be identical to the 100, except for the addition of a 22-foot fuselage section. This stretch will accommodate an additional 101 passengers, bringing the total passenger capacity up to 656. The MTOW for the 200 will be 1.21 million pounds. At the present time, the Airbus A3XX-200 is the largest NLA that is being considered for development.

THE FUTURE DEVELOPMENT OF NLA.

It is anticipated that the development of NLA will continue in the future, bringing newer, larger transport aircraft from each of the three major aircraft manufacturers. The ultimate size of these new aircraft is not certain but can be projected by following industry trends in aircraft design. By investigating these trends, we can predict the direction in which key aircraft dimensions like weight, wingspan, length, tail height, and wheelbase can be expected to grow. For the immediate future, it is reasonable to assume that aircraft closely related to the models described earlier will be introduced. By understanding the philosophy aircraft manufacturers use in developing families of aircraft, we can predict how the NLA characteristics will evolve over the next 20 years.

The introduction of a new aircraft model is triggered by a manufacturer's desire to enter a particular niche in the competitive transport aircraft market. The new aircraft is designed to specially fit the market niche with the appropriate range capability, passenger capacity, and operating characteristics to make it attractive to prospective airline customers. Manufacturers are targeting most NLA for service on long-range, high-capacity international routes throughout the world.

Traditionally, aircraft manufacturers begin the aircraft development process by introducing a baseline model of an aircraft that can later be modified to carry more weight and travel further distances. This is true with aircraft families like the Boeing 747. The original B747-100 was introduced in 1970 as the largest transport aircraft of its time. Over the last twenty-six years, we have seen the B747 grow through the 100, 200, 300, and the most current, 400 versions. Within each of these models, several different weight or cargo versions have also been introduced into service. NLA will undoubtedly follow the same type of growth pattern.

Aircraft manufacturers historically have pursued aircraft development programs very similar to the one depicted in figure 1. Manufacturers start with the introduction of a baseline aircraft design, as shown in the lower left corner of the figure, and then later redesign a modified version of the same aircraft that is capable of flying longer routes. This is generally done through the

addition of fuel tanks and/or higher efficiency engines. Once this step is complete, the aircraft may then be reintroduced in a stretched version capable of carrying more passengers. This model of the aircraft, because of its increase in weight and size, loses a bit of its range. The result is, essentially, a trade off of range for capacity.

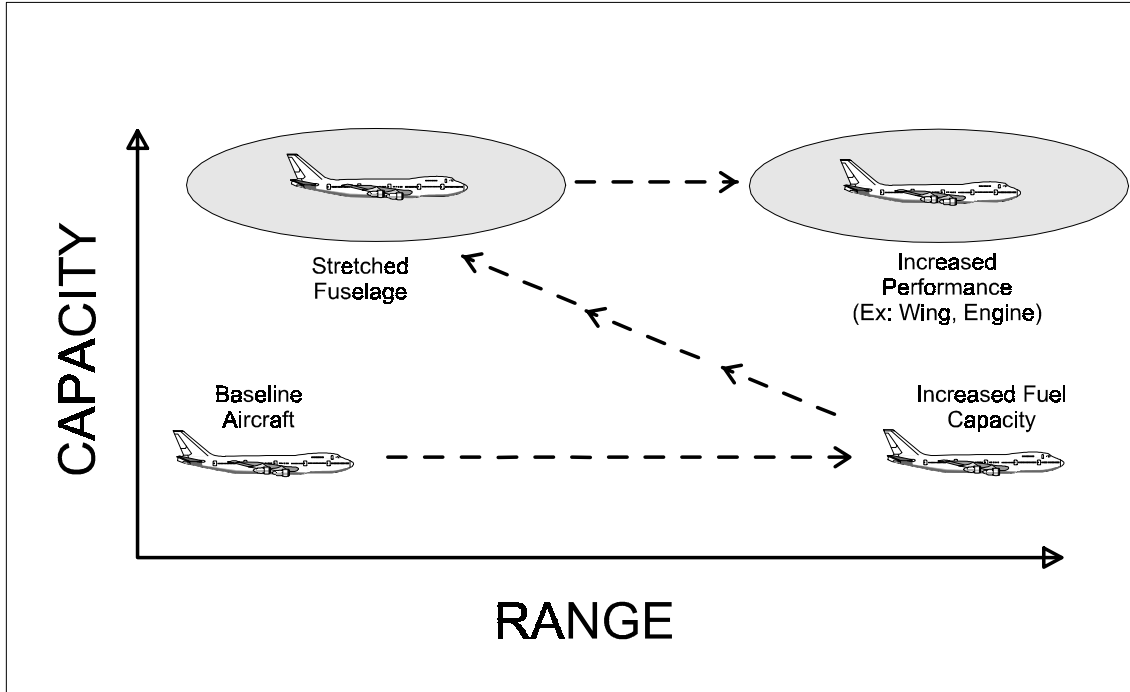

FIGURE 1. TYPICAL AIRCRAFT DEVELOPMENT PROGRAM

The final phase of the aircraft development program may involve the modification of the stretched version to again allow it to fly longer distances. The Boeing 747 and 777 projects have, in a way, followed this pattern. The introduction of the B747-500, 600, and the B777-300 is an attempt by Boeing to obtain both the high capacity and the long-range objectives of a B747 and 777 design program. McDonnell Douglas has also followed this pattern with the DC-10 project. The design of the MD-XX and the MD-XX LR model will follow the recent MD-11 introduction to reach the high-capacity, long-range aircraft market. Airbus Industries, however, is developing their double-deck NLA from an all new aircraft design. This is the beginning step for Airbus and will most likely result in a number of future A3XX introductions. Airbus has already indicated that they are considering the development of a stretched A3XX-100, called the A3XX-200. Combination cargo/passenger, freight, high capacity, or extended range versions of the A3XX are all possibilities for future design enhancements.

The HSCT project, because of its reliance on new technology, will involve considerable time to produce an actual flying aircraft. McDonnell Douglas and Boeing have both indicated to the industry that they intend to produce the HSCT as soon as possible. Arrival of the first HSCT, if on schedule, is expected to occur after the year 2005. The future of the HSCT beyond the introduction of a baseline unit is most uncertain and will have to be determined at a later date.

The average weight of commercial aircraft has increased consistently over the last thirty years. Figure 2, which illustrates the trend in aircraft maximum takeoff weights for large aircraft introduced over the past 3 decades, demonstrates how the upward trend in aircraft weight can be expected to continue to increase with the introduction of first and future generations of NLA (indicated by the clear and shaded boxes). Note how there are two separate trends depicted on this chart. One trend, which is represented by the upper line, illustrates the weight characteristics of the larger transport aircraft used for long international flights. The second trend, which is shown as the lower line, shows the weight trend of the large transports used on shorter routes. These lines are parallel and are most likely to continue on the same track in the future. By taking these trends and their associated values into consideration, we can predict that the weights of future long route NLA will increase to 1.6 million in the next 20 years, while the shorter route NLA will also rise to 1 million pounds during the same period of time. This prediction is illustrated by the shaded area in figure 2.

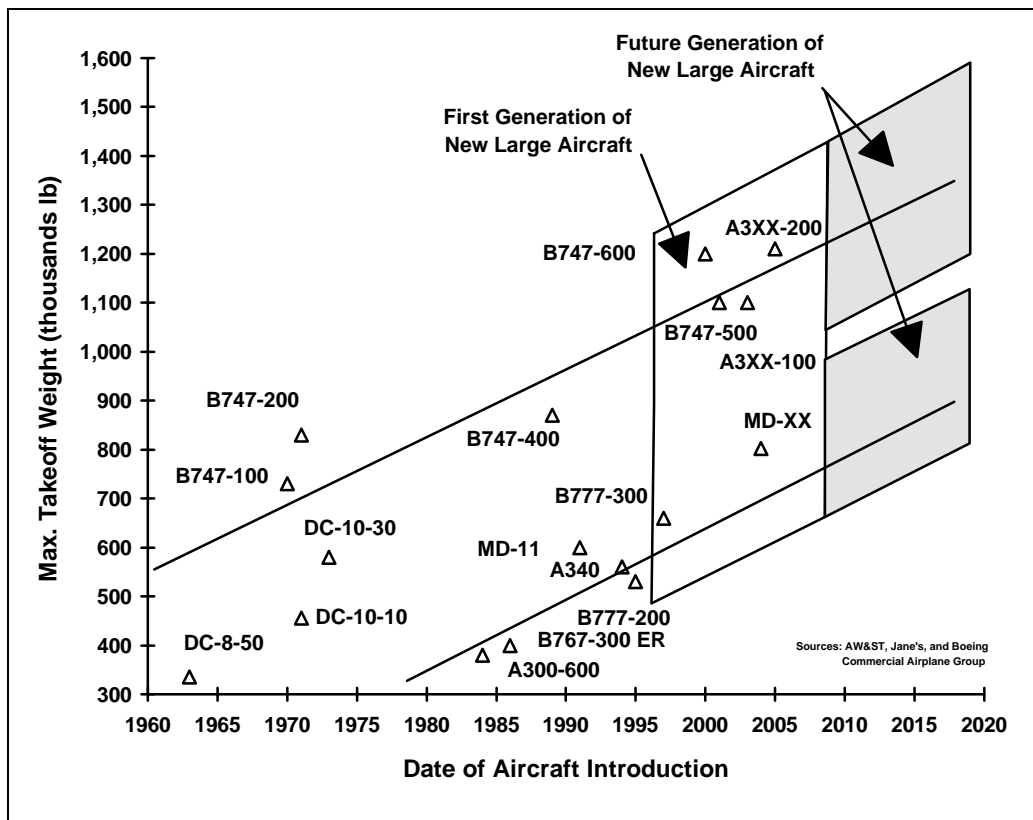

FIGURE 2. MAXIMUM TAKEOFF WEIGHT TRENDS

Commercial transport aircraft have also increased in wingspan length over the last several years. As will be discussed in this report, many NLA will be classified in the largest airplane design group category, Group VI, recognized by the FAA. The largest wingspan included in this design group category is 262 feet. Current trends in aircraft wingspans indicate that they will continue to grow but may be curved to remain within the parameters of current design Group VI criteria. Figure 3 illustrates the trend in aircraft wingspan design for both past aircraft and future NLA. It is anticipated that the curve will reach a plateau and result in maximum values at or below 262

feet for two reasons. The first is that the development of higher efficiency wings will permit the carrying of more weight without an increase in size. The second reason, actually an unavoidable restriction, is that airports will be unable to fit aircraft that are much larger than 262 feet on their taxiways and runways without compromising the required separation standards for aircraft operating at the airport. The future demand for faster transport aircraft may also influence the trend in wingspan length, as they will most likely be equipped with swept wings for faster flight.

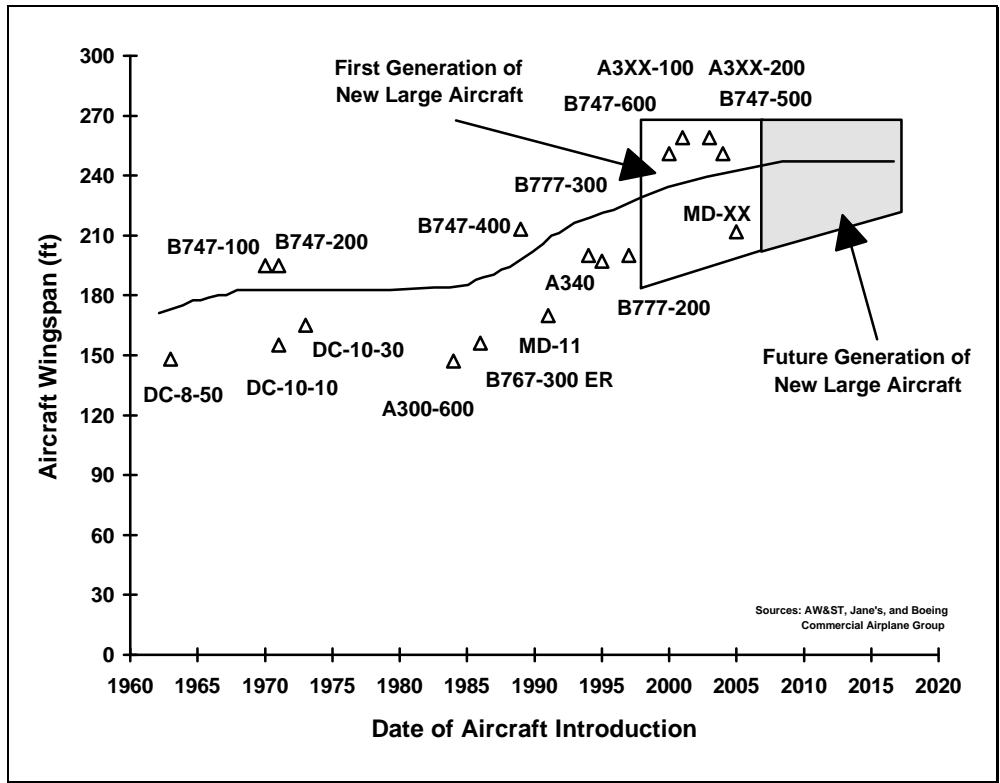

FIGURE 3. AIRCRAFT WINGSPAN TRENDS

Other design characteristics of future NLA that can be predicted based on historical trends are the fuselage length, tail height, and landing gear wheelbase. These three elements, in general, are very closely related to each other. The wheelbase of the aircraft is typically a function of the fuselage length; the longer the fuselage, the longer the required wheelbase. Likewise, as the size of the aircraft increases, the height of the aircraft increases. Figures 4 and 5 illustrate the current trends in aircraft length, height, and wheelbase dimensions for aircraft introduced over the past 30 years. Future derivatives of NLA are also expected to continue to grow in size and may be expected to have fuselage lengths upwards of 280 to 300 feet. As a result, they can also be expected to have wheelbase values upwards of 140 to 150 feet and tail heights over 80 feet. The projected fuselage length, tail height, and wheelbase dimensions for future generation NLA are depicted in figures 4 and 5.

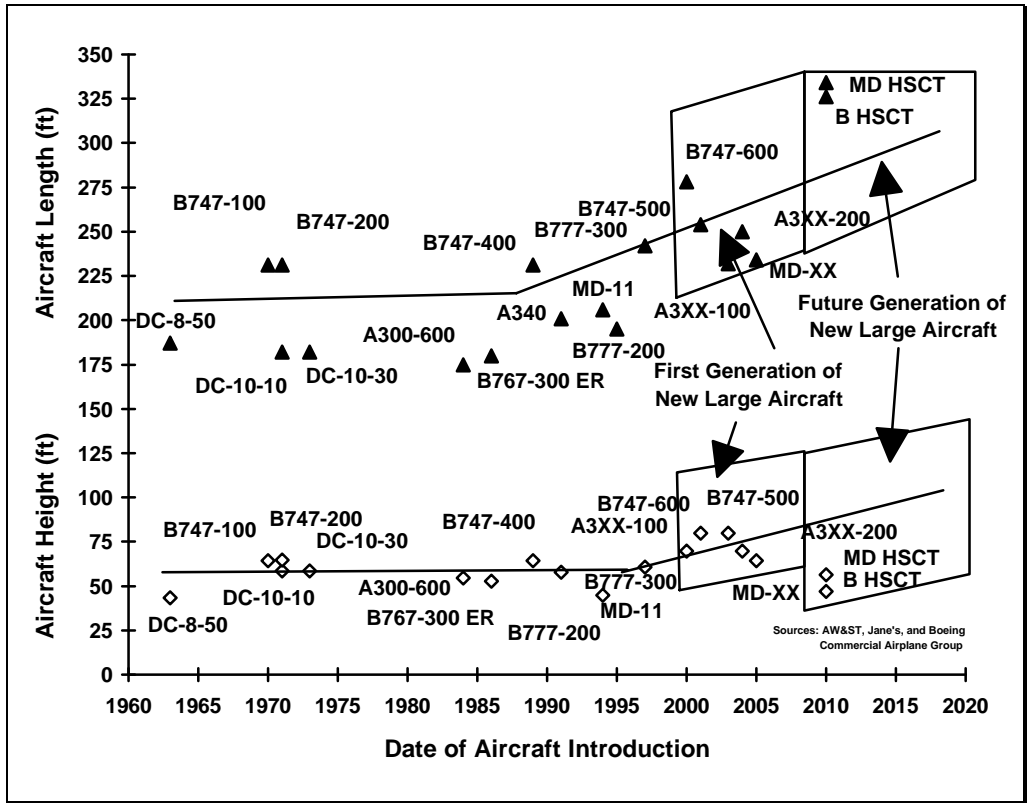

FIGURE 4. AIRCRAFT LENGTH AND HEIGHT TRENDS

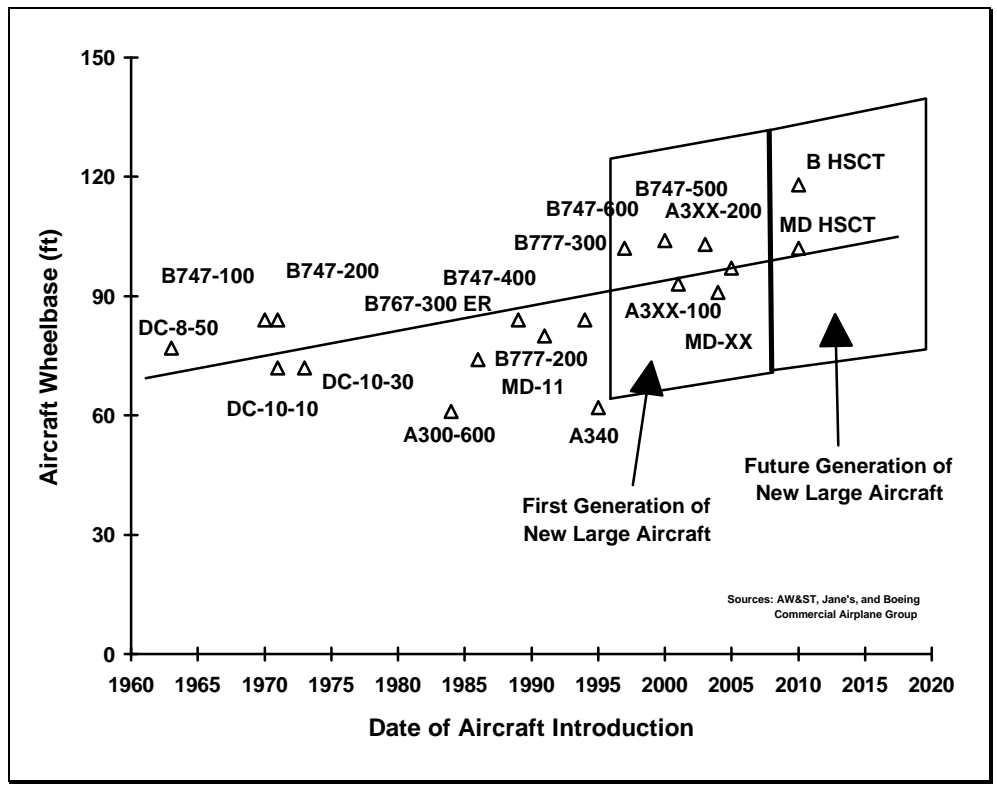

FIGURE 5. AIRCRAFT WHEELBASE TRENDS

AIRPORT DESIGN RATIONALE

Current FAA airport design standards provide reference and guidance for airport designers and forecasters relating to construction and configuration of all runways, taxiways, aprons, and terminals. The design of these items is based primarily on the size, approach speed, and number of aircraft the airport is expected to serve. The FAA established the Airport Reference Code (ARC) system to aid designers in properly determining the size of the runway, taxiway, or terminal that is needed at an airport. Advisory Circular AC 150/5300-13, Airport Design, defines ARC as “a coding system used to relate airport design criteria to the operational and physical characteristics of the airplanes intended to operate at the airport.” The geometry of all surfaces at an airport is designed specifically for the largest aircraft or group of aircraft that will be operating at the airport. This assures that all aircraft will be provided with the proper obstacle clearance and separation requirements while maneuvering on the airport’s paved surfaces.

The determination of the ARC for an airport is based on two elements: the approach category and the design group of the largest aircraft which the airport is designed to accommodate. An aircraft’s approach category is determined by the aircraft’s approach speed, or 1.3 times the aircraft’s stall speed in a landing configuration. The airplane design group is based on the aircraft’s wingspan. These classifications are defined in table 1. An airport’s ARC includes both a letter and a number for the critical aircraft approach category and the airplane design group, respectively. For example, an airport designed to handle an aircraft with an approach speed of 156 (1.3 x 120 knot stall speed) knots and a wingspan of 160 feet would be designated by an ARC of D-IV.

TABLE 1. AIRPORT REFERENCE CODE (ARC) DETERMINATION

Aircraft Approach Category	Aircraft Approach Speed (stall speed x 1.3 in knots)
A	0 to 90
B	91 to 120
C	121 to 140
D	141 to 165
E	166 or more
Airplane Design Group	Aircraft Wingspan in Feet (Meters)
I	0 up to but not including 49 (15)
II	49 (15) up to but not including 79 (24)
III	79 (24) up to but not including 118 (36)
IV	118 (36) up to but not including 171 (52)
V	171 (52) up to but not including 214 (65)
VI	214 (65) up to 262 (80)

The new large aircraft’s physical and operational characteristics will therefore dictate the design of future airports and their facilities. As the characteristics of the aircraft increase, an airport’s ARC may have to be increased to the next higher level. By applying the dimensions and operational characteristics of the new large aircraft to the FAA airport reference code shown in table 1, we can determine the ARC for NLA. Stall speed data for most of the NLA are not available at this time and will remain unknown until final wind tunnel tests are completed. For the purpose of this report, an assumption is made that the aircraft will have a typical approach speed of approximately 150 knots. Table 2 shows these NLA design group identifications. Note that all of the NLA, despite their large size, fall within the existing categories.

TABLE 2. NLA ARC DETERMINATION

NLA	Wingspan In Feet (Meters)	Aircraft Approach Category	Airplane Design Group			Airport Reference Code (ARC)
			Group IV	Group V	Group VI	
B747-400	213 (65)	D		X		D-V
B747-500X	251 (77)	D			X	D-VI
B747-600X	251 (77)	D			X	D-VI
B777-200B	200 (61)	D		X		D-V
B777-300	200 (61)	D		X		D-V
B HSCT	155 (47)	D	X			D-IV
MD-XX	212 (65)	D		X		D-VI
MD HSCT	128 (39)	D	X			D-IV
A3XX-100	259 (79)	D			X	D-VI
A3XX-200	259 (79)	D			X	D-VI

IMPACT ON AIRPORT DESIGN

The FAA’s current airport design standards provide guidance to airport operators for the design, operation, maintenance, and expansion of airports. Preliminary research into the affects of NLA on airport design has shown that the introduction of NLA will significantly affect nearly every U.S. airport intending to accept them. In order to better understand the magnitude of this impact, it is best to discuss individual airport characteristics. The following section of this report identifies elements of airport planning and design that are likely to be affected by the NLA. Specifically, it includes both airside and landside issues. It also identifies the existing FAA airport standards and recommended practices which may require revisions and/or provision of supplemental information.

AIRSIDE IMPACT—GEOMETRICAL DESIGN OF RUNWAYS AND TAXIWAYS.

As previously stated, the FAA has developed a comprehensive system to classify airport dimensional requirements by the size of the most demanding aircraft or group of aircraft intending to operate at the airport. Based on this system, it has been determined that NLA will generally fall into design group VI and will require the appropriate clearances and dimensional

standards for this group. Airports that are expecting to serve these aircraft will attempt to expand and upgrade their facilities to meet the design criteria of design group VI. However, at many airports, it will not be possible to fully achieve many of the required design criteria. Indeed, it would appear that NLA requiring design group VI facilities may be operating for many years in a system built to design group V standards.

Design standards for all geometrical airport design criteria are included in AC 150/5300-13. It covers runway and taxiway design standards for all size aircraft, even as large as NLA. The FAA Airport Design Program discussed in appendix 11 of AC 150/5300-13 was used to produce the Airport Design Airplane and Airport Data sheets contained in appendix A of this report. By referencing these reports, it can be shown that the existing design groups do in fact accommodate NLA. Thus, the introduction of the NLA does not rely on revised design standards but mainly on the airport’s ability to expand its facilities to meet the appropriate design standards. This section of the report will explain these design standards and identify critical areas that may need to be addressed by airports in preparing for the arrival of the NLA.

There are, of course, some design standards that do not adequately anticipate the increased requirements of NLA, and the extent to which they will have to be changed will have to be addressed also.

RUNWAY DESIGN. This section addresses current standards for the various elements of runway design, which include length, width, shoulders, blast pads, and stopways that might be affected by the introduction of NLA. AC 150/5300-13 contains information for determining the sizes and characteristics of these runway design elements.

Runway Length. Airports expecting to accommodate NLA will require specific planning data to determine whether current runway lengths are sufficient to accommodate NLA. NLA, with their high-lift generating wing designs, will have runway length requirements equal to, or less than today’s B747-400 (see table 3). Therefore, an airport that can currently accommodate a B747-400 should not require any extensions or modifications to the length of their runways.

TABLE 3. NLA RUNWAY LENGTH REQUIREMENTS

NLA	Runway Length Required In Feet (Meters)
B747-400	11,000 (3,353)
B747-500X	≤11,000 (≤3,353)
B747-600X	≤11,000 (≤3,353)
B777-200B	10,500 (3,200)
B777-300	≤11,000 (≤3,353)
B HSCT	11,000 (3,353)
MD-XX	9,800 (2,987)
MD HSCT	10,800 (3,292)
A3XX-100	11,000 (3,353)
A3XX-200	11,000 (3,353)

AC 150/5325-4A, Runway Length Requirements for Airport Design, provides design standards and guidelines for determining recommended runway lengths for civil airports. As stated in the AC, the recommended length for the primary runway is determined by considering either (1) a family of airplanes having similar performance characteristics or (2) a specific airplane having the longest runway requirement. To support the latter scenario, the AC will require several changes to include the flight characteristics of NLA. The majority of these changes will be in the form of aircraft data sheets added to appendices 2 and 3 of the AC. In fact, aircraft data sheets for all other non-NLA introduced after 1991 should be added to bring the document up to date. Scenario (1), which states that the runway length is based on a group of aircraft having similar performance characteristics, is used to make general approximations for the length of a runway for a group of airplanes with a maximum certificated takeoff weight of more than 60,000 pounds. Figure 6, from AC 150/5325-4A, illustrates this concept by showing the relationship that exists between runway length and length of haul. Note that the maximum haul distance shown on the diagram is 7,000 statute miles, whereas the route segments for some NLA are estimated to be 8,500 nautical miles (9,781 statute miles) with future derivatives of the NLA flying even longer segments. The formula used to define the curves in the chart (provided in figure 6) produces a recommended runway length of 10,546 feet. This chart will require modifications to include longer route segments being served by NLA. With new, higher efficiency wing and engine design, NLA will most likely fly significantly farther and require less runway than their older counterparts.

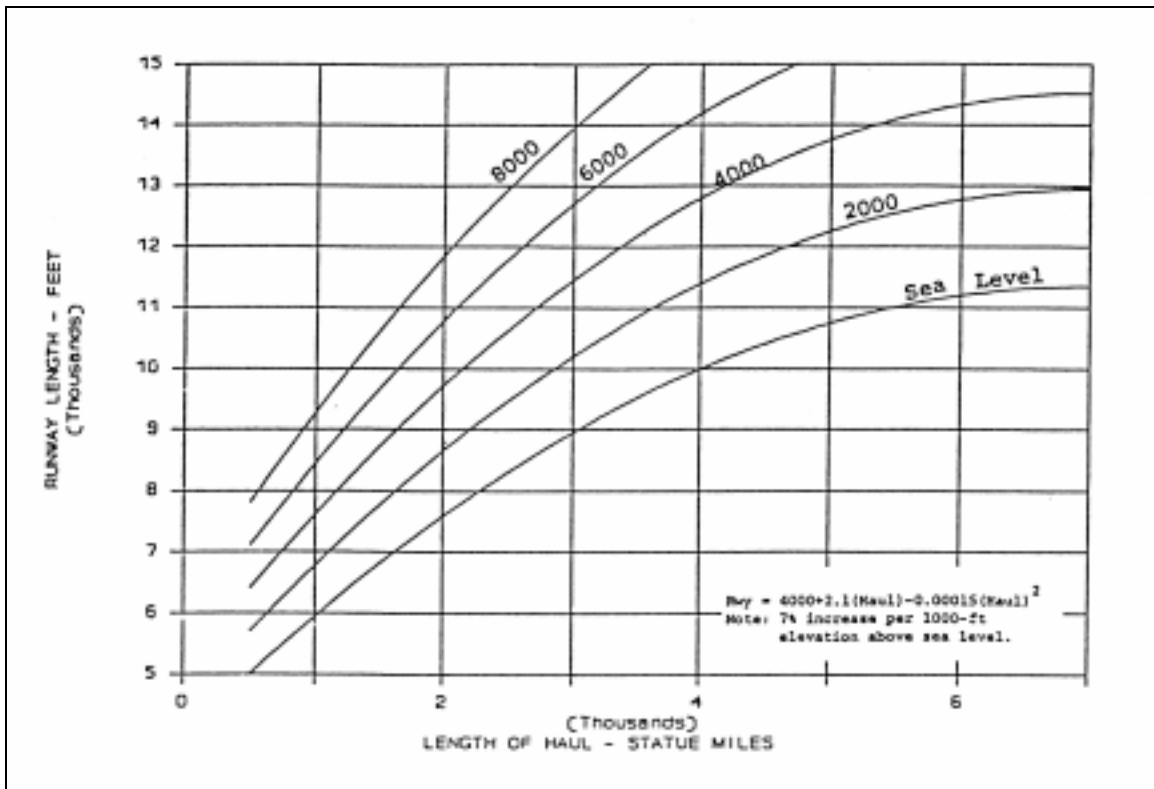

Source: AC 150/5325-4A

FIGURE 6. NLA RUNWAY LENGTH REQUIREMENTS

Runway Width. The width of many primary runways becomes a concern with the introduction of the NLA. Airports planning to accommodate NLA, but not currently having design group V or VI capability, may be required to widen their runways to meet the appropriate design group requirements recommended in FAA AC 150/5300-13. Chapter 3 of AC 150/5300-13 presents runway width standards addressing operations conducted during reduced visibility and includes a table that contains the data for determining the width of runways for design groups I through VI in approach categories C and D. AC 150/5300-13 also indicates that runway width requirements for aircraft design groups IV, V, and VI are 150, 150, and 200 feet, respectively. The wingtips of proposed NLA such as the Airbus A3XX, with its wingspan of 259 feet, will extend approximately 30 feet over each edge of the widest recommended runway. Figure 7 illustrates the relationship of the proposed Airbus A3XX-100 with the current recommended runway widths for design group IV, V, and VI airports. Required runway widths, as calculated by current FAA standards, for all NLA can be found on the appropriate sheets in appendix A of this report.

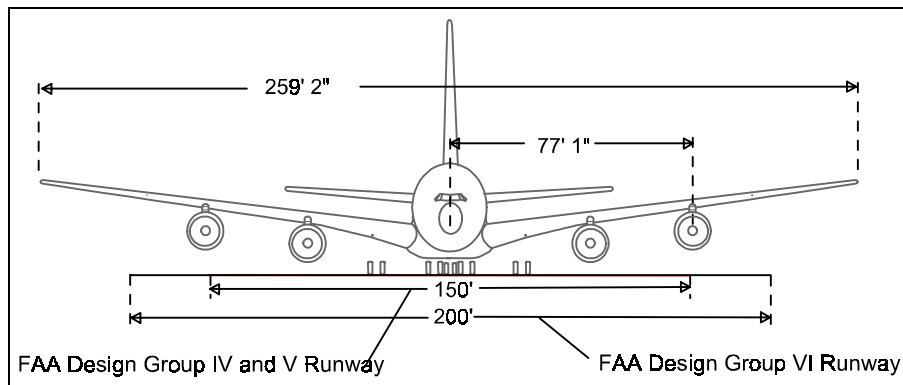

FIGURE 7. RUNWAY WIDTH VERSUS NEW LARGE AIRCRAFT

The current requirements for runway widths appear to present no immediate problem for NLA so long as airports have the appropriate widths for the applicable design group. Additional research may be required to determine if any additional safety margins are required for NLA operations. It is assumed that most NLA will be equipped with state-of-the-art devices such as automatic landing and rollout, eliminating significant deviation from the centerline of the runway. In cases where it is likely that NLA will deviate from the centerline, it may be appropriate to recommend an expansion of runway width sufficient to safely handle the larger main gear width of the NLA.

Airports that currently have D-IV status or lower will undoubtedly be required to expand their runways to facilitate the NLA that are considered design group D-V and D-VI aircraft. Airports that currently meet D-VI status will not require any runway width modifications, unless, for other reasons, is it determined otherwise.

In situations where runway widening is prohibited because of inadequate space for expansion, it may be possible that design group VI aircraft could be permitted to operate on 150-

foot-wide runways. This, of course, depends heavily on the accuracy of the automatic landing and rollout system assumed to be used on NLA.

Runway Shoulders. Runway shoulders, as defined in AC 150/5300-13, provide resistance to blast erosion, accommodate the passage of maintenance and emergency equipment, or the occasional passage of an airplane veering from the runway. Current shoulder width requirements are 25, 35, and 40 feet for design groups IV, V, and VI, respectively (AC 150/5300-13). For design groups V and VI, a stabilized or paved shoulder surface is typically required.

Chapter 8 of the AC provides additional information on the effects and treatment of jet blast. It also contains figures with jet blast velocity versus distance plots for representative airplanes. The velocity distance curve for a Boeing 747 contains a note warning that at maximum values, the velocity of the jet blast may extend 25 feet beyond the wing tip and to a height of 30 feet above ground level (AC 150/5300-13). It is quite possible that with higher thrust engines, as are being planned for NLA, these values could increase significantly. In fact, on NLA with wing mounted engines, maximum jet blast velocities could extend up to 20 feet beyond the runway shoulders, as is shown in figure 8. The higher thrust, in addition to the extended engine location, could cause serious soil erosion to existing runways or present a danger to objects around them. The location of airport signs, lights, and other visual aids may also be affected by this problem. Data on the effects of jet blast by NLA are not available at this time but should be studied as soon as available. It may be necessary to increase the recommended widths of runway shoulders to minimize jet blast damage from NLA operations.

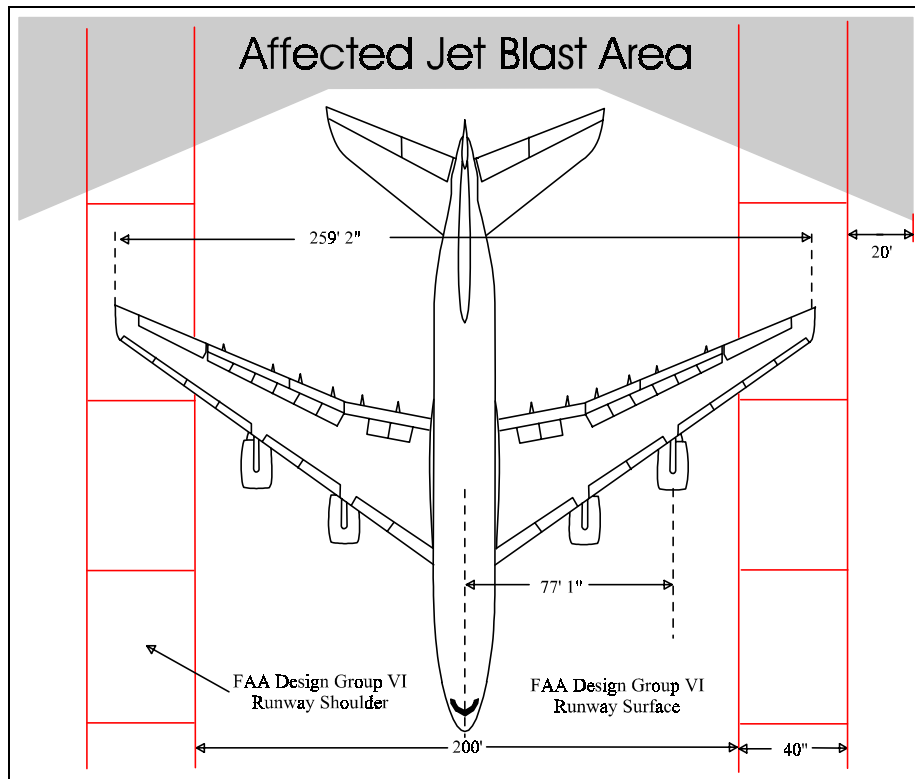

FIGURE 8. PROJECTION OF AFFECTED NLA JET BLAST AREA

Runway shoulders are also required to support an occasional passage of an aircraft veering from the runway. As with most airport surfaces, this area must be designed to support the weight of the largest aircraft for which the airport is designed. NLA, some weighing in excess of 1 million pounds, may challenge current runway shoulder pavement standards if they have not already been designed to support such heavy loads. Strength standards for runway shoulders will need to be further investigated.

Blast Pads. Runway blast pads are provided to prevent blast erosion damage beyond the ends of the runway. AC 150/5300-13 addresses the recommended design standards for runway blast pads. Aircraft produce the largest amounts of engine blast during the application of takeoff power. This jet blast travels beyond the threshold of the runway at speeds that can be in excess of 300 mph, depending on the aircraft. Without a proper blast pad installation, severe damage to the ground, other aircraft, vehicles, or any object behind the aircraft may occur. Rocks, dirt, and other debris can be launched into the air like missiles, damaging anything in their path. To reduce the possibility of damage, this area is normally paved with concrete or asphalt. Table 4 contains design criteria for blast pad installations at design group D-IV, D-V, and D-VI airports (AC 150/5300-13).

TABLE 4. RUNWAY BLAST PAD DESIGN STANDARDS

Airplane Design Group	IV	V	VI
Runway blast pad length	200 ft (60 m)	220 ft (66 m)	280 ft (84 m)
Runway blast pad width	500 ft (150 m)	500 ft (150 m)	500 ft (150 m)

The Boeing 747-400 is currently powered by four wing-mounted jet engines that produce approximately 58,000 pounds of thrust each, depending on the model of the engines. The Boeing 747-500 and 600 are also being designed with four engines but will have substantially higher thrust at 75,000 pounds each. Both Boeing and Airbus are considering the use of engines that produce in excess of 90,000 pounds of thrust. In comparison, NLA will be producing significantly larger amounts of jet blast. Current design standards for runway blast pads, as presented in table 4, will need to be tested to verify their ability to properly contain NLA jet blast. It may be appropriate to expand both the length and width requirements of current blast pad specifications to minimize blast erosion by NLA.

Runway Stopways. A runway stopway is an area beyond the takeoff runway end, centered on the extended runway centerline, and intended to decelerate an airplane during an aborted takeoff (AC 150/5300-13). Stopway design, with the exception of strength, should not be directly affected by the introduction of NLA. Airports with stopways, however, that are currently utilizing the declared distance concept to accommodate large aircraft like the B747-400 may need to verify that the weight bearing capacity of the stopway is sufficient for NLA. If it is not strong enough, it will need to be strengthened or excluded from the takeoff distance available calculations for NLA.

TAXIWAY DESIGN. This section presents current standards for various elements of taxiway design to include width, shoulders, and turns that might be affected by the introduction of NLA. Taxiway design standards, as recommended by the FAA, are included in chapter 4 and appendix 9 of AC 150/5300-13.

The current design standards for airport taxiways could be one of the most crucial airport design features that will be affected by the introduction of NLA. Preliminary research into the compatibility of NLA and existing taxiway networks has shown that on many taxiway routes, NLA will not be able to operate without their wingtips intruding into the safety areas of adjacent taxiways, runways, or terminal areas. At many airports, areas that can be used for taxiway widening or relocation do not exist, preventing the airports from easily accommodating NLA. Solutions to this problem might include the restricting or limiting NLA operations to certain periods of low traffic thereby reducing the chance of violating safety areas of other aircraft or limiting NLA operation to certain routes on the airport that provide adequate clearance. This approach may only be a temporary fix. If manufacturers continue on their present production course, there will be more and more NLA operating in the next few years. Permanent solutions to problems associated with NLA operations need to be identified before they are introduced into service.

Taxiway Width. AC 150/5300-13 identifies taxiway dimensional data appropriate for airports serving all design groups of aircraft. They can be designed to accommodate a group of aircraft or only a single most demanding aircraft. If it is determined that multiple aircraft of the same higher design group will be consistently operating at the airport, the design standards in table 4-1 of the AC will apply (part of which is shown as table 5). In other cases where there is only one aircraft type of a higher design group operating at the airport, the taxiways can be designed to fit that aircraft as discussed in appendix 9 of the AC.

Until now, the B747-400 has been the largest aircraft that airports have expanded to accommodate. NLA, which are much larger, will present a requirement for higher values of taxiway separation and taxiway clearance standards. Many airports simply do not have the room to grow and may not be able to host NLA without special site specific operational measures.

The required width of taxiways for the three larger aircraft design groups, as shown in table 4-1 of the AC, appear in table 5 of this report. Taxiway width, as specified in the AC, is designed to be wide enough to provide adequate clearance between the outside edge of the main landing gear and the edge of the taxiway pavement. The clearance between the outside edge of the main gear and the pavement edge is called the taxiway edge safety margin. Taxiway edge safety margin data is also provided in table 5. Normal deviations from the taxiway centerline at speeds up to 20 mph are also taken into account when determining these taxiway width values.

TABLE 5. TAXIWAY DESIGN REQUIREMENTS

Airplane Design Group	IV	V	VI
Taxiway width	75 ft (23 m)	75 ft (23 m)	100 ft (30 m)
Taxiway edge safety margin	15 ft (4.5 m)	15 ft (4.5 m)	20 ft (6 m)

The minimal required taxiway width for a given aircraft can be found by adding twice the taxiway edge safety margin to the width of the aircraft's main landing gear (at the outside edge). NLA listed in this report do not present any direct problems with the FAA taxiway design criteria itself but will require many airports to expand their taxiway surfaces to meet the criteria for the next higher design group.

Taxiway Shoulders. Taxiway shoulders, like runway shoulders, provide protection against jet blast erosion and engine ingestion problems. Many of today's larger aircraft, including NLA, have wing mounted engines that overhang the edge of the paved taxiway. These engines, with their high thrust output, are very susceptible to damage or to causing damage to other aircraft in the area. Taxiway shoulder widths, as recommended in AC 150/5300-13, are typically 25, 35, or 40 feet for design groups IV, V, and VI, respectively. Design groups V and VI require stabilized or paved surfaces on the taxiway shoulders.

Figure 9 depicts a larger NLA (A3XX-100) on a standard design group VI taxiway. Note the locations of the engines in relation to the taxiway shoulder. The outboard engine is approximately 27 feet beyond the taxiway edge or 13 feet from the outer edge of the taxiway shoulder. Jet blast produced by the outboard engines will most likely extend beyond the limits of the recommended taxiway shoulders, possibly causing damage to airport lights, signs, and other surrounding equipment. Requirements for wider taxiway shoulders may be needed to prevent any damage to the aircraft itself, the airport surface, or other aircraft. Solutions might include a requirement for NLA to shut down their outboard engines while taxiing on the airport surface.

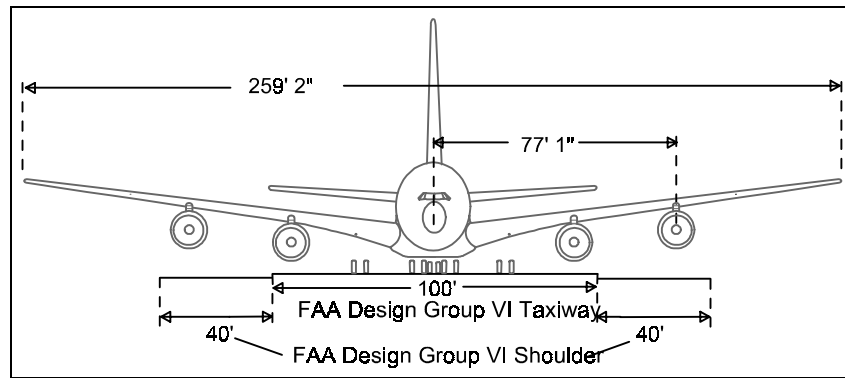

FIGURE 9. NLA ON TYPICAL DESIGN GROUP VI TAXIWAY

Taxiway Turns. With significantly increased wheelbase dimensions, NLA will be challenged with negotiating existing taxiway turns and curves. AC 150/5300-13 provides guidance to determine the required dimensions for taxiway turns and also includes formulas for designing custom taxiway fillets for these turns. A major factor in determining required taxiway turn radii is the type of centerline tracking method being used by the aircraft while negotiating the taxiway turns. The method generally preferred by industry is called cockpit over centerline, where the pilot attempts to steer the aircraft such that the cockpit remains centered over the centerline of the taxiway. Using this method, the rear of the aircraft will track to the inside of the turn. This normally requires a fillet on the inside of the curve to provide support for the main

gear as it makes the turn. The second method is called judgmental oversteering, where the pilot overshoots the taxiway centerline to allow room for the trailing main gear to make the turn. This method usually requires the addition of a fillet on the outside of the curve to provide support for the nose gear as it makes the turn. Judgmental oversteering, compared to cockpit over centerline, maximizes the use of existing pavement and minimizes the amount of pavement fillet that will need to be added to accommodate the aircraft. Airports in concert with carriers will need to assess their current taxiway systems to determine which of the two methods will be required for NLA on their taxiways.

Certain NLA, such as the HSCT aircraft, will have significant problems negotiating many taxiway turns because of its 118-foot wheelbase. The HSCT, although it is considered a design group IV aircraft, will most likely be unable to maneuver on turns that are designed for other aircraft in its group like the B757. It may be appropriate for the FAA to require design group V or VI taxiway standards for the HSCT because of its inability to maneuver on design group IV taxiways.

AC 150/5300-13, chapter 4, provides guidance to determine if given taxiway fillet designs provide standard taxiway edge safety margins for various wheelbase/undercarriage width combinations. It further states that custom designed pavement fillets are necessary when the undercarriage dimensions fall outside of the standard taxiway edge safety margins presented in the given figures (see table 5). The AC also provides a relatively complex series of equations to determine the required custom fillet design for the given aircraft. A computer program, as described in appendix 11 of the AC, is also available to solve these equations.

Figure 10 depicts the chart given in the AC for design group V and VI aircraft using judgmental oversteering. This chart is used to determine whether the current recommended taxiway turn dimensions will provide adequate taxiway edge safety margins for an aircraft with a given undercarriage configuration. Current NLA designs, when applied to the graphs in figure 10, do not fall within the dimensions shown on the graphs.

Airports expecting to serve NLA will need to verify that currently existing taxiway turns have sufficient fillet pavement and are of the proper radii, or they may be forced to restrict the movement of the NLA by using runways or other large paved surfaces for taxiing purposes.

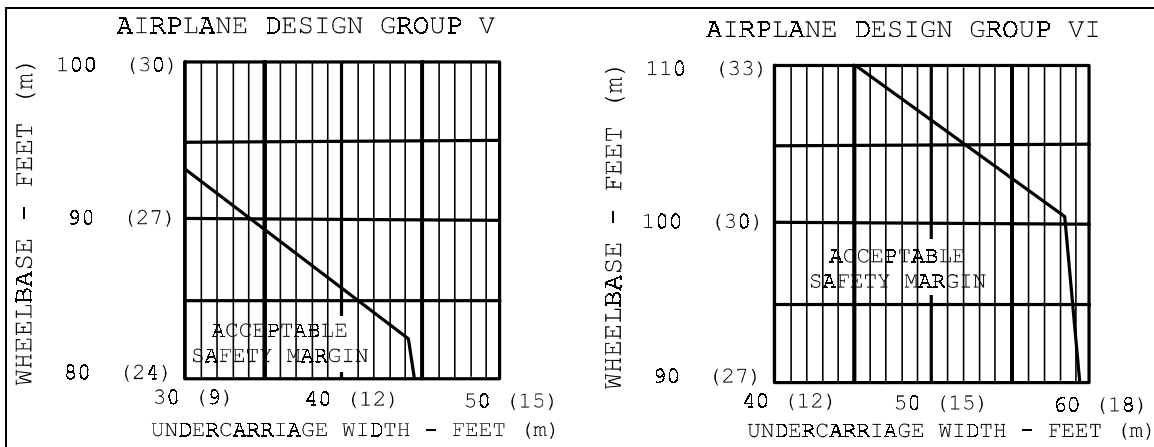

Source: AC 150/5300-13

FIGURE 10. DETERMINATION OF TAXIWAY EDGE SAFETY MARGIN DURING JUDGMENTAL OVERSTEERING

TAXIWAY SEPARATION STANDARDS. Most airports that plan on accommodating NLA are large hub airports that have a complex taxiway system that provides direct routing to runways, terminals, aprons, etc. It is most important that the introduction of NLA does not disturb the programmed flow of current traffic patterns.

As previously mentioned, many of today's airports have built as many taxiways and aprons as possible in the limited amount of space they have available. Simple taxiway relocation projects to provide proper taxiway separation distances for NLA may be virtually impossible due to lack of available space. During NLA operations, airports may have to restrict movement of NLA to specific taxiway routings or to require other traffic to keep clear of the area while the NLA taxi to their destination. Either solution will present increased traffic congestion and problems for air traffic control (ATC).

Current FAA taxiway separation and clearance standards are provided in AC 150/5300-13, chapter 2 and appendix 9. Specifications for taxiway/runway, taxiway/taxiway, taxiway/taxilane, taxilane/taxilane, taxiway/object, and taxilane/object separation are provided in these two sections of the AC. The FAA's Airport Design Program, as discussed in appendix 11 of AC 150/5300-13, is very useful for determining separation for individual aircraft or design group. Data sheets produced by this computer program are included in appendix A of this report. Separation standards for each of the NLA discussed in this report have been included.

It has been determined that all NLA fall within FAA's existing aircraft approach category and design group system. Because all airport separation standards for both taxiways and runways are based on this system, required separation distances for NLA will be no different than those of other aircraft in the same design group. Table 6 shows the required separation standards for various elements as extracted from AC 150/5300-13.

TABLE 6. RUNWAY AND TAXIWAY SEPARATION STANDARDS FOR APPROACH CATEGORY C AND D AIRCRAFT

Item	Airplane Design Group		
	IV	V	VI
Runway centerline to:			
Taxiway centerline	400 ft (120 m)	400 ft* (120 m)	600 ft (180 m)
Taxiway centerline to:			
Parallel taxiway centerline	215 ft (65.5 m)	267 ft (81 m)	324 ft (99 m)
Fixed or movable object	129.5 ft (39.5 m)	160 ft (48.5 m)	193 ft (59 m)
Taxilane centerline to:			
Parallel taxilane centerline	198 ft (60 m)	245 ft (74.5 m)	298 ft (91 m)
Fixed of movable object	112.5 ft (34 m)	138 ft (42 m)	167 ft (51 m)

*Separation distance is 400 ft for airports below a field elevation of 1,345 ft, 450 ft for airports between 1,345 and 6,560 ft, and 500 ft for airports above an elevation of 6,560 ft.

Chapter 2 of AC 150/5300-13, titled Airport Geometry, contains specific guidance for determining the physical placement of parallel runways, taxiways, and taxilanes in several different scenarios. NLA dimensional data, when applied to the various formulas and equations in this chapter, appear to present no immediate problems for taxiway/runway separation, so long as the airport meets the requirements of the appropriate design group.

Airports that do not, or cannot, meet the required design group criteria will impose operation restrictions to permit the operation of designated NLA while not meeting current design standards. In this particular area of airport design, however, it appears that NLA will not be compatible with the runway and taxiway separation standards for lower design groups. For example, figure 11 depicts a Boeing 747-600 on design group V and VI parallel taxiways while an aircraft of equal size is operating on the runway. The B747-600, when placed on the design group V taxiway with 400 feet runway/taxiway separation, intercepts the inner-transitional object free zone (OFZ) specified in AC/5300-13. The A3XX-100 and 200, as a further example, produce the same situation. The operation of NLA belonging to design group VI on airports with design group V capability, as demonstrated in this example, will result in operational restrictions. This may prevent many airports from accepting NLA if operational waivers cannot be justified.

In summary, NLA are compatible with the FAA’s currently recommended design standards for design group VI criteria runway and taxiway separations since they have not exceeded the upper limits of the design group criteria.

The FAA’s current design standards for taxiway/taxiway and taxiway/taxilane separation may be one area that could be revised to allow airports to accommodate NLA without requiring significant modifications to existing taxiway structures. Parallel taxiway separation is currently determined by the formula 1.2 times the wingspan of the most demanding aircraft, plus 10 feet. NLA designs such as the A3XX, with a wingspan of 259 feet, would require a taxiway centerline

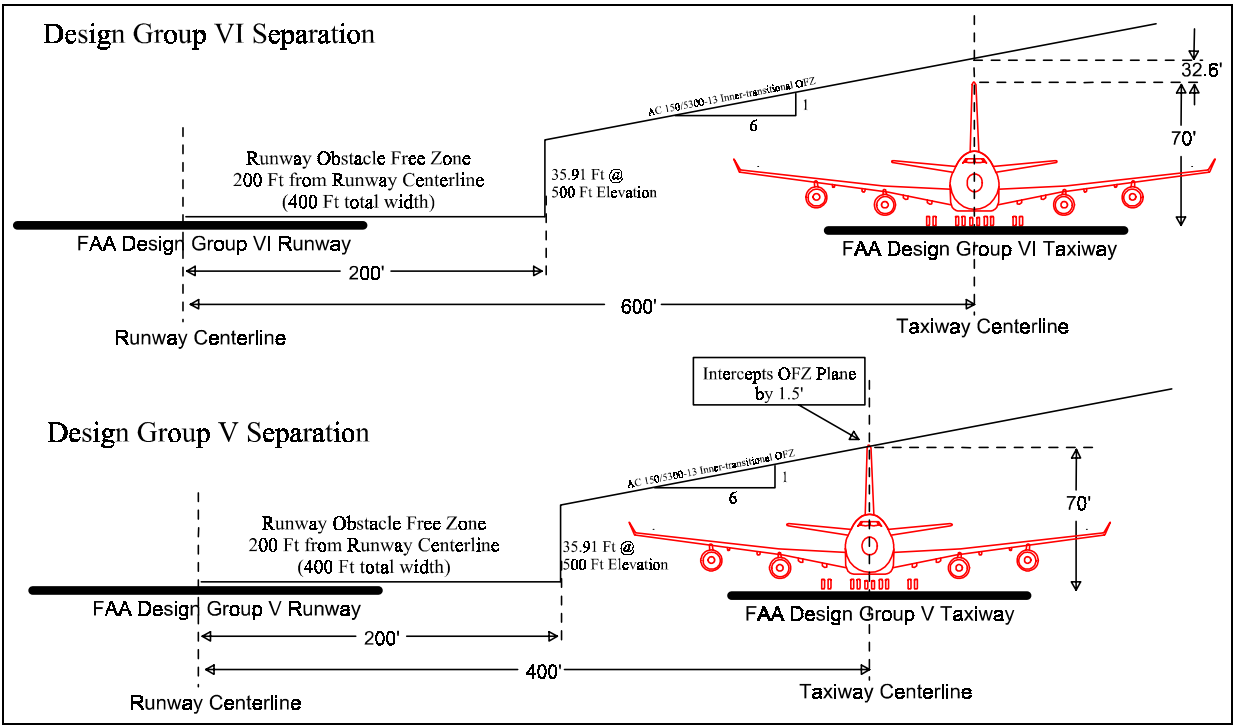

FIGURE 11. DEPICTION OF NLA ON DESIGN GROUP V AND VI PARALLEL TAXIWAY

to centerline separation of 320.8 feet. This provides a wingtip separation of 61.8 feet between the wingtips of two A3XX aircraft when both are on parallel taxiways. The formula does become more relevant when applied to determining the separation standards of two smaller aircraft with shorter wingspans. For example: a small corporate jet with a wingspan of 42 feet would have 18 feet of separation from wingtip to the wingtip of another similar aircraft. The computed separation distance increases dramatically as the aircraft gets larger in size. Separation of this magnitude may not be required between parallel taxiways/taxilanes involving NLA, as it is most likely that they will be taxiing at slower speeds than smaller aircraft, thus permitting the aircraft to maneuver at closer distances. Technological developments such as ground looking cameras and global positioning systems may also contribute to greater accuracy in taxiing operations.

Another area of separation criteria that could be modified to accommodate NLA is taxilane and taxilane/object separation. Current FAA design standards for taxilane separation are included in AC 15/5300-13, chapter 4 and appendix 9. Taxilane centerline to object separation dimensions, as shown in table 5, are equal to 0.60 times the wingspan of the most demanding aircraft plus 10 feet. A taxilane object free area, which is to be clear of objects at all times during aircraft operation, is twice the taxilane to object separation for a single taxilane or 2.3 times the wingspan of the most demanding aircraft plus 30 feet for dual taxilanes. Figures 12 and 13 depict a NLA positioned on a currently recommended single and dual taxilane. By referencing the formulas for determining the required width of the taxilane for an Airbus A3XX, the recommended width of the single taxilane object free area shown in figure 12 would be 330.8 feet.



FIGURE 12. NLA ON SINGLE TAXILANE

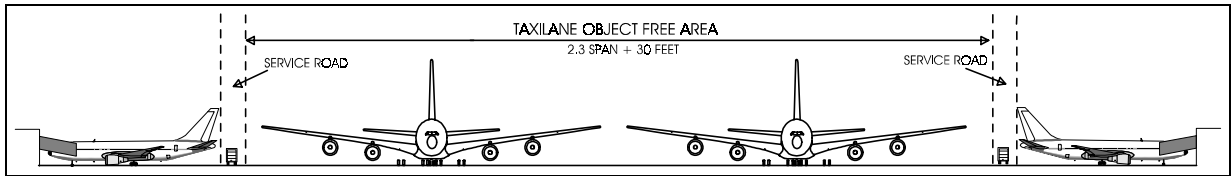

FIGURE 13. NLA ON DUAL TAXILANE

TAXIWAY HOLDING BAYS AND BYPASS TAXIWAYS. Air traffic control, during periods of high activity, sometimes utilize holding bays and/or bypass taxiways to accommodate aircraft that are not ready to takeoff or are awaiting clearance instructions. By positioning the aircraft out of the main flow of traffic, other aircraft are able to continue onto the runway without any delay. This is most beneficial in areas where traffic bottlenecks and congestion are very common.

FAA airport design standards state that holding bays and bypass taxiways are required to possess similar standard taxiway edge safety margins, separation, and clearance standards as parallel taxiways. Airports that have holding bays or bypass taxiways will need to expand them to meet the appropriate clearance and separation requirements of NLA. This, of course, may be challenging because of the limited amount of available space for expansion. At some locations, in fact, it could be impossible. The use of holding bays and bypass taxiways will not be essential to the operation of NLA but will relieve the traffic congestion that is expected to occur with the introduction of NLA.

RUNWAY AND TAXIWAY BRIDGES. Current standards for runway and taxiway bridge design appear in chapter 7 of AC 150/5300-13. Like runways and taxiways, bridges are required to be of appropriate dimensions based on the size characteristics of the largest aircraft expected to use them. The wingspan of the larger NLA should not present any problems for current bridge design standards, assuming the bridges were designed to meet the proper width requirements specified in the AC. For example, a design group D-VI NLA would require a bridge that meets the same clearance and width requirements as a design group D-VI taxiway. The weight of NLA, however, may cause other problems. AC 150/5300-13 states the following in reference to airport bridge design:

“Runway and taxiway bridges must support both static and dynamic loads imposed by the heaviest airplane expected to use the structures. Airport

authorities should evaluate the potential need to accommodate heavier airplanes and construct any runway or taxiway bridge accordingly. Overdesign is preferable to the cost and operational penalties of replacing or strengthening an underdesigned structure at a later date. Airplanes weighing up to 873,000 pounds are in use today. Airplanes weighing 1,000,000 pounds or more may exist by the turn of the century.”

NLA, in their current configurations, will weigh between 850,000 and 1.2 million pounds at MTOW. If airports do not have bridges capable of supporting these high MTOWs, they will have to undertake the expensive, time consuming strengthening mentioned above. In addition to the requirement for higher weight capacity, the AC requires proper blast protection for vehicles or personnel crossing under the bridge and sufficient width for the maneuvering of rescue and firefighting equipment. The large wingspan and the location of outboard engines of NLA will make this difficult and may require additional modifications to existing bridges that do not meet these requirements. FAA design standards will require modification to reflect advanced methods for designing bridges capable of handling NLA.

RUNWAY AND TAXIWAY CULVERTS. Culvert design, as discussed in AC 150/5320-5B, Airport Drainage, are structures designed to allow water to pass under a runway, taxiway, or roadway. Though they are not a major element of airport design, it is most important that their design be capable of handling the weight of NLA. AC 150/5320-5B provides information on the required depths and diameters of the culvert system for given overlying pavement surfaces. The AC contains basic parameters for culvert design for aircraft weights up to 1.5 million pounds on traditional style landing gear configurations such as the double tandem found on a B747. NLA are predicted to weight around 1.2 million pounds and will feature complex gear designs with triple- and quad-tandem gear posts. The wheel loading factors associated with these gear configurations will have to be evaluated to determine whether the individual wheel loading values will present any future problems for culvert design. FAA design standards should be revised to include provisions for constructing culverts capable of handling NLA landing gear loads. Airports with culvert installations that are expected to support NLA will need to revisit the weight limitations of their culvert designs and strengthen or reinforce them as required.

AIRSIDE IMPACT—AIRPORT PAVEMENT DESIGN.

An essential element of airport design that will be critical in determining an airport’s ability to host NLA is the strength of the airport’s pavement. With their massive operating weights, NLA will be substantially heavier than today’s wide-body aircraft and may require stronger, thicker pavements. Boeing’s recent introduction of the B777 presented several problems in current airport pavement design and led to the development of a dedicated AC that addresses pavements designed specifically for the B777-200; AC 150/5320-16, Airport Pavement Design for the Boeing 777 Airplane. It was determined that existing design methodologies, as described in AC 150/5320-6D, Airport Pavement Design and Evaluation, did not address the aircraft’s unusual landing gear design. The methodologies for designing the B777 can be used to design NLA pavements as well; however, stronger pavements may be required. It is very likely that NLA will

present the same problem and may require new AC’s dedicated to discussing specific pavement design required to accommodate them.

Airport pavement design issues are beyond the scope of this report. As aircraft weights continue to grow, along with increases in the complexity of gear layout, the FAA must continue to research and develop new and improved methods of pavement design. In the very near future, the FAA in cooperation with the aviation industry, will complete a state-of-the-art pavement test machine at the FAA William J. Hughes Technical Center at Atlantic City International Airport, NJ. This facility will be used to refine and extend the new design methodologies. This test machine will simulate years of aircraft traffic in a matter of a few months.

The aircraft data sheets in appendix A of this report include diagrams of each NLA’s prospective landing gear design and the associated weights that they can be expected to support. To better understand the magnitude of the pavement design issue, consider the values presented in table 7. These values were extracted from the aircraft data sheets in appendix A. Note that the number of tires and gear posts on the NLA, in comparison to the B747-400, are supporting significantly more weight than those of typical smaller transport aircraft. Because of this, the individual wheel loading that is produced by each tire will be substantially higher. It is this factor that presents several problems for current airport pavement design standards. The FAA will need to further investigate this issue.

TABLE 7. NEW LARGE AIRCRAFT GEAR CONFIGURATION

NLA	Maximum Takeoff Weight in Pounds (Kilograms)	Number of Tires on Nose Gear	Number of Main Gear Posts	Number of Tires on Main Gear
B747-400	875,000 (396,893)	2	4	16
B747-500X	1,200,000 (544,311)	4	4	20
B747-600X	1,200,000 (544,311)	4	4	20
B777-200B	632,500 (286,897)	2	2	12
B777-300	660,000 (299,370)	2	2	12
B HSCT	644,100 (292,158)	2	2	16
MD-XX	802,000 (363,781)	2	3	16
MD HSCT	753,000 (341,555)	2	3	18
A3XX-100	1,124,357 (509,999)	2	4	24
A3XX-200	1,212,542 (549,999)	2	4	24

AIRSIDE IMPACT—SAFETY ISSUES.

An airport’s ability to quickly and effectively confront an emergency situation is a very important safety issue that will require significant research with the introduction of NLA. FAA design standards for airport emergency plans can be found in two sources: Federal Aviation Regulations (FARs) and Advisory Circulars. These documents contain information and guidelines for airports to follow in developing, maintaining, and providing sufficient protection in the event of

an airport disaster. With the dramatic increase in aircraft size, it is most likely that the FAA’s design standards for various safety issues will require revisions. This section of the report will attempt to identify areas that may need to be investigated.

FIRE PROTECTION AND EQUIPMENT. The introduction of NLA will present new challenges to current aircraft rescue and firefighting (ARFF) equipment and practices. In determining the size and capability of the rescue and firefighting equipment required at an airport, the size and physical characteristics of the NLA will play an important role. The aircraft will be larger, higher off the ground, and in some cases, involve multiple levels of occupancy. In fact, they may possess many characteristics very similar to those of a typical structure fire. Airport firefighters, who currently do not have the experience or equipment to battle such fires, will need to be equipped with long ladders, booms with skin penetrating devices, or other unique types of firefighting equipment to properly extinguish the fires. The FAA will need further research on this subject to determine whether changes to current design standards are required.

Current FAA standards for rescue and firefighting equipment are included in both FARs and Advisory Circulars. It is beyond the scope of this report to include standards that are regulatory in matter, but it is important that we understand how ARFF requirements are developed. FAR Part 139, which covers regulatory airport requirements, contains several sections that pertain to ARFF requirements. Aircraft rescue and firefighting indexes are, in accordance with FAR Part 139.315, designated by an index letter (i.e., A, B, C, D, or E) that represents the size of the largest aircraft the airport is prepared to handle in the event of a fire or rescue situation. The ARFF index code issued to an airport is based on the length of the largest air carrier aircraft intending to operate at the airport and frequency of operation. Table 8 contains the aircraft length groups that are used to determine the index as they appear in Part 139 of the FARs.

Part 139.315 further states that “if there are five or more average daily departures of air carrier aircraft in a single index group, the longest index group with an average of 5 or more daily departures is the index required for the airport. In addition, if there are less than five average daily departures of air carrier aircraft in a single index group serving that airport, the next lower index from the longest index group with an air carrier aircraft in it is the index required for the airport.”

TABLE 8. ARFF INDEX DETERMINATION

Index Category	Largest Aircraft Length
A	Under 90 feet (27 m)
B	At least 90 feet (27 m) but less than 126 feet (38 m)
C	At least 126 feet (38 m) but less than 159 feet (48 m)
D	At least 159 feet (48 m) but less than 200 feet (61 m)
E	At least 200 feet (61 m)

All of the NLA discussed in this report fall into a minimum level of Index Category E. This means that an ARFF Index Category D airport can presently accommodate an NLA as long as they do not schedule more than four daily NLA operations. NLA fuselage lengths range from the Boeing 777-200B, the shortest at 206 feet, to the longest McDonnell Douglas HSCT at 334 feet. Index Category D, as currently recommended, may not be sufficient to provide adequate fire protection for an HSCT, and a review is required. In fact, the HSCT should fall into the same ARFF index category as a 200-foot or longer aircraft. It is most likely that current new index categories will have to be created to provide the additional protection that is needed for NLA.

AC 150/5210-6C, Aircraft Fire and Rescue Facilities and Extinguishing Agents, provides background information for determining the amount of equipment and agent that is required to properly support the appropriate index levels. The amount of firefighting agents that each ARFF index airport is required to provide is determined from calculating the size of a hypothetical fire which, in turn, is based largely on fuselage length. Two elements of this calculation are the theoretical critical fire area (TCA) and the practical critical fire area (PCA). The theoretical fire area, as described in AC 150/5210-6C, was developed to determine the size of the area around the target aircraft that must be isolated from fire. This enables ARFF personnel to protect passengers as they attempt to evacuate the aircraft. Theoretical critical fire area is determined by the following formula:

$TCA = L \times (100' + W)$, when the average aircraft length (L) is more than 65 feet and W is the width of the aircraft fuselage. ($TCA = L \times (40' + W)$ when L is less than 65 feet).

A practical critical fire area, which is also discussed in this AC, is a smaller area immediately around the aircraft fuselage that has been determined to be the most likely to contain passengers in a survivable crash. The practical critical fire area is 67% of the theoretical critical fire area. The B747-400, for comparative purposes, has a practical critical fire area as follows:

$TCA = 231 \times (100' + 21)$ (fuselage length = 231', fuselage width = 21')
 $TCA = 27,951$
 $PCA = 0.67 \times 27,951 = 18,727$ sq. ft.

The McDonnell Douglas HSCT, by following this formula, requires a practical critical fire area of:

$TCA = 334 \times (100' + 16)$ (fuselage length = 334', fuselage width = 16')
 $TCA = 38,744$
 $PCA = 0.67 \times 38,744 = 25,958$ sq. ft.

Note the difference in the practical critical fire areas for these two aircraft that are currently categorized in the same ARFF index level. Such disparities can be further illustrated by calculating the amount of water that would be needed to properly cover the practical critical fire area for the HSCT, as described in AC 150/5210-6C.

The quantity of water for distribution of aqueous film forming foam (AFFF) from an ARFF vehicle can be determined by following additional formulas in AC 150/5210-6C. The amount of water, in gallons, required for defeating a fire on an HSCT is determined as follows:

HSCT Values:

25,958	Practical critical fire area
<u>x 0.13</u>	Solution Application Rate (ARFF) 92/min/ft ²
(3,374.54)	Q1 x 1 minute (quantity for initial application)
<u>x 1.7</u>	Percentage factor for Q2 (for airport Index Category E airports)
(5,736.71)	Q2 (quantity to continue suppression)

Thus (3,374.54) + (5,736.71) = 9,111.25 gallons (total water quantity)

In conclusion, the HSCT dimensions indicate a requirement of approximately 9,111 gallons of water. Current ARFF Index Category E requirements specify that a minimum 6,000 gallons, in total, are transported on three firefighting vehicles. This is over 3,000 gallons below what is actually needed for HSCT. Airports with Index Category D capability, which would be permissible with less than five HSCT daily operations, would be even lower. These examples indicate that the design standards for determining ARFF indexes may need to be modified to include an Index Category F or G that would require additional equipment, water, foam, and other firefighting agents appropriate for a specific NLA.

Other areas of AC 150/5210-6C, Aircraft Fire and Rescue Facilities and Extinguishing Agents, that may need to be revised include the additional rescue equipment that is to be carried on the airport fire trucks. Currently required equipment includes such items as sledge hammers, crowbars, and other hand tools. Of particular interest is the requirement for each airport fire department to have an extension ladder, two section type, capable of being extended up to 18 feet or a flat type step ladder 18 feet long and 24 inches wide. It is assumed that this ladder would be used by ARFF personnel to gain entry into the passenger compartment of an aircraft that is on fire. It is important to understand that many of the door sill heights of NLA are as much as 17 feet and higher. The B747 and the A3XX, with their double-deck design, will have door sill heights as high as 26 feet. (Exact door sill heights for each aircraft can be found on the aircraft data sheets in appendix A of this report.) The required 18-foot ladder is currently insufficient for reaching many of these door locations. In addition, if one of these NLA were to have a collapsed nose gear, the doors that are aft of the main gear would then be substantially higher. It is quite possible that requirements for longer ladders, or traditional ladder style fire trucks, should be added to the minimum firefighting equipment list.

EMERGENCY PROCEDURES. Airports that are expecting to serve future NLA will need to enhance their current procedures for dealing with aircraft emergencies. NLA will carry significantly more passengers than today's aircraft and will require that additional emergency equipment, supplies, and personnel are available to properly respond to a possible NLA emergency. Advisory Circular 150/5200-31, Airport Emergency Plan, provides guidance to airport management on the preparation, demonstration, and actual execution of an airport

emergency plan. An Airport Emergency Plan (AEP), as defined in AC 150/5200-31, provides “the framework upon which the various response capabilities are identified and organized and the outline for response management to bring them into play when the occasion demands.” Specific activities and tasks that will need to be performed by designated personnel are carefully listed, one by one, to provide a confusion-free procedure to follow during an airport emergency.

An airport’s emergency plan should encompass procedures that are capable of handling an emergency involving the largest passenger aircraft served by the airport. The size of this aircraft’s fuselage, as discussed already, directly determines the amount of ARFF vehicles and fire-extinguishing agents that will be needed to effectively put out a fire. The seating capacity of the aircraft, which is also an important factor in an airport emergency, directly determines the number of rescue personnel, medical supplies, and medical facilities that will be needed to handle the injuries and/or casualties associated with the aircraft emergency. Airports expecting to serve NLA will need to verify that their current airport emergency plan can encompass the increased size and capacity of a potential catastrophic aircraft emergency.

NLA will be carrying 20 to 30 percent more passengers than today’s jumbo jet. This will require airports to designate additional community support and assistance during the execution of an emergency plan. It must be verified that community medical facilities and hospitals will be capable of transporting and treating the increased number of injured passengers. Every element of the AEP will need to be re-evaluated to verify its compatibility with NLA accidents.

AC 150/5200-31 recommends that civil airports practice a full-scale execution of an airport’s emergency plan once every 3 years. This full-scale test assists in identifying deficiencies, misunderstandings, or confusion that may exist in the applicable AEP. If possible, it is recommended that the drill be based on an accident involving the most demanding aircraft operating at the airport. For airports that serve NLA, this will involve a significant increase in the number of participants and the possibility of a very chaotic situation. The FAA, in cooperation with individual airports, will need to identify unforeseen problems that may arise in simulating an emergency situation involving a NLA.

Airport medical facilities, as currently specified, should store and maintain an appropriate amount of medical supplies to treat the passengers of a possible aircraft emergency situation. AC 150/5210-2A, Airport Emergency Medical Facilities and Services, provides suggestions and guidance for airport management in establishing a basic first aid facility. Though many airports that will serve NLA will most likely have a well established medical facility, it may be necessary for the FAA to update design standards for medical facilities to address the possibility of mass triage.

TRAINING FACILITIES. Rescue and firefighting personnel that will be serving at airports expecting to host NLA may need to receive additional training on fighting a fire on a NLA. AC 150/5220-17A, Design Standards for an Aircraft Rescue and Firefighting Training Facility, contains standards for designing and operating an ARFF training facility. The facility should have a mock-up of an aircraft fuselage section that can be ignited and controlled from a remote location. The purpose of the facility is to train ARFF personnel in combating live aircraft fires

while in a controlled environment. Typically, for Index Category E airports, the fuselage section at the facility is at least 75 feet long. With the introduction of NLA, it may be appropriate for the FAA to require training mock-ups that represent the bilevel fuselage sections common to several of the NLA included in this report. In addition, the aircraft mock-up may be elevated to a higher level above the ground to better simulate the NLA posture. It is most important that ARFF personnel receive effective training and experience on battling NLA fires. AC 150/5220-17A should be revised to include parameters for developing training facilities for NLA firefighting.

DEICING FACILITIES. NLA deicing requirements, for the most part, should be very similar to those for current jet aircraft. Airports that currently have dedicated deicing facilities will most likely be required to modify the size of the facilities. AC 150/5300-14, Design of Aircraft Deicing Facilities, contains standards for designing, constructing, and operating an aircraft deicing facility. In the AC, it states that deicing facilities must provide proper object clearance criteria as specified in AC 150/5300-13. Essentially, deicing facilities must provide the same obstacle clearance and separation as required for a typical taxiway. Airport operators do have the option, however, of positioning the deicing facilities on a nonmovement area, thereby reducing the required object clearing criteria to those of a taxilane. In either case, facilities that will be serving NLA will be required to have the sufficient object separation distances that are appropriate for the design group of the particular NLA.

Chapter 3 of AC 150/5300-14 discusses the actual size requirements for an aircraft deicing pad. A deicing pad, in its simplest form, consists of an aircraft parking area and a maneuvering area for mobile deicing vehicles (see figure 14). The dimensions of the aircraft parking area, where the aircraft is parked to receive the deicing/anti-icing treatment, are the width of the wingspan and fuselage and the length of the most demanding aircraft using the deicing pad. The maneuvering area for the deicing vehicles, which encircles the aircraft, is 12.5 feet wide. This lane must be dedicated to each individual deicing pad and cannot be shared by an adjacent pad. For some NLA, such as the Airbus A3XX-200 and the McDonnell Douglas HSCT, deicing pads will have to be significantly larger than those currently in use. A properly designed deicing pad for the A3XX-200 would be 279 feet long by 284 feet wide at its widest point. The MD-HSCT would require a deicing pad 359 feet long by 153 feet wide at its widest point. Multiple aircraft deicing facilities, which have adjacent deicing pads, will also require modifications. Separation standards for adjacent deicing pads are, from parallel centerline to centerline, the largest of the aircraft design group's wingspan plus 25 feet or the taxiway centerline to centerline separation standards specified in AC 150/5300-13. For nonmovement deicing pad locations, the same concept is used, but the separation is, from centerline to centerline, the largest of the aircraft design group's wingspan plus 25 feet or the taxilane centerline to centerline separation standards specified in AC 150/5300-13.

Other areas of concern for deicing operations involving a NLA include the effects of jet blast, turning radius, and bypass taxiing capabilities. The design of a NLA deicing facility must ensure that the jet blast produced by the NLA, while breaking away from a parked position, is not directed towards other aircraft in adjacent deicing pads. In addition, a NLA should not obstruct other passing aircraft or cause delays in traffic flow. It may be prudent for the FAA to

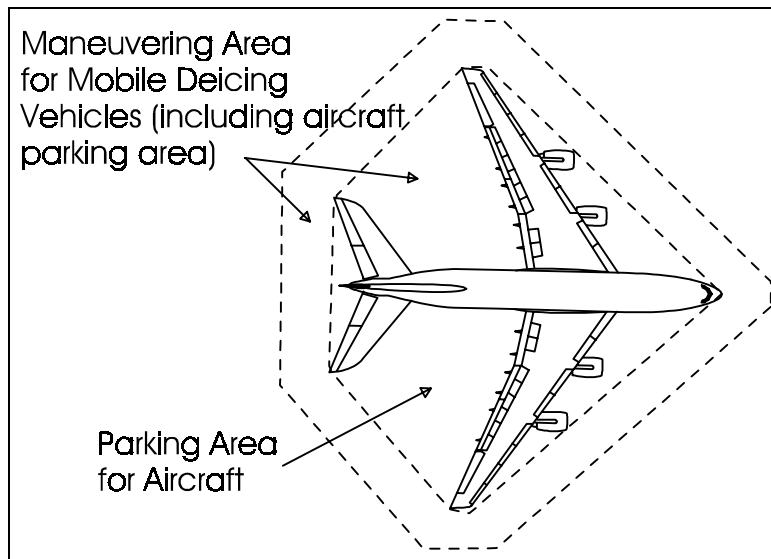

FIGURE 14. AIRCRAFT DEICING PAD

recommend that deicing operations for NLA be done at gate locations where the aircraft was loaded. This may eliminate the requirement for enlarged deicing pads or the possibility of creating longer delays during periods of inclement weather. Airports that do not have the proper drainage systems to recover the deicing/anti-icing chemicals at the gate locations may need to install them or else consider enlargement of their existing deicing pads.

DEICING OPERATIONS. The deicing procedures for NLA, as compared to those of traditional jet transports, will involve substantially larger amounts of deicing fluid, manpower, and application equipment. This is due to the aircraft's larger size and greater overall surface area that must be treated with the deicing/anti-icing chemicals.

Typical procedures for deicing an aircraft, as found in AC 120-58, Pilot Guide—Large Aircraft Ground Deicing, are designed to assist both pilots and ground personnel in developing a quick and efficient method for deicing large aircraft. Because NLA will be so much larger than today's aircraft, it may be appropriate for the air carrier to designate multiple deicing vehicles for each NLA. Without multiple vehicles simultaneously applying deicing fluid, the permissible holdover times (HOT) for the applied fluid may near expiration by the time the aircraft is completed. If the expiration time occurs before the aircraft is cleared for takeoff, the aircraft would then be required to be re-deiced and re-anti-iced. This, of course, will cost air carriers more money and manpower and may also cause delays in airport traffic flow. With multiple applicators, the fluid can be simultaneously applied to the entire aircraft, minimizing the total elapsed time from the beginning of deicing/anti-icing fluid application to the completion of the final aircraft surface treatment.

ENGINE CLEARANCES OVER OBSTRUCTIONS. Basic obstructions that are currently found at airports such as signs, lights, navigational aids, or snowbanks (during the winter season) should not present any immediate danger to the operation of NLA because of the increased height

of their wings. The aircraft's engine nacelles and wingtips will be much higher than those of typical transport aircraft, reducing the possibility of contacting currently installed obstructions.

Current airport sign standards, as recommended in AC 150/5340-18C and 44F, Standards for Airport Sign Systems, are such that they very likely will be affected by NLA. The minimum and maximum values for height and distance from the pavement edge must be made compatible with the dimensions of the NLA. AC 150/5340-18C recommends that sign installations must provide "12 inches of clearance between the top of the sign and any part of the most critical aircraft using, or expected to use, the airport when the aircraft's wheels are at the defined pavement edge." Figure 15 shows the maximum permissible heights and distances from the pavement edge for size 1, 2, and 3 signs adjacent to an A3XX-100. While there is obviously no probability that the engine nacelles or wingtips would ever impact the airport sign, it is quite possible that existing signs could be harmfully exposed to increased levels of jet blast and/or wake vortices.

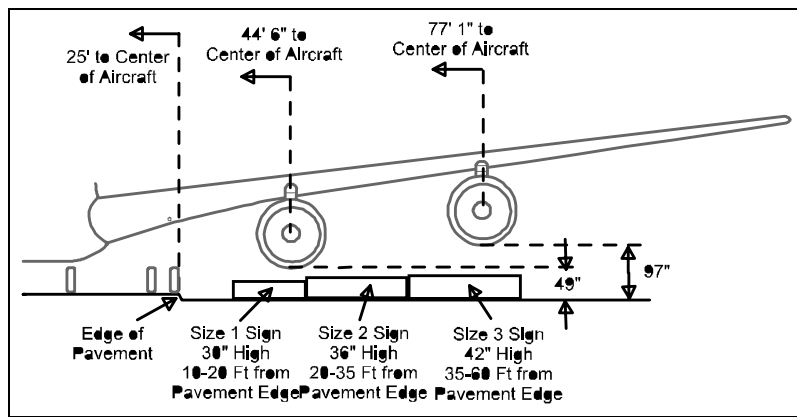

FIGURE 15. NLA SIGN CLEARANCE

With increased takeoff weights and substantially higher thrust engines, NLA will be producing significantly higher levels of vortex and exhaust turbulence during their takeoff and landing operations. It is quite possible that airport signs could be damaged or destroyed if they encounter a direct hit by the turbulence of a NLA's jet blast. At this time, however, the exact turbulence characteristics of the NLA aircraft are unknown. It is most important that the FAA be alert to the possibility of this problem and be prepared to investigate the need to improve sign standards.

Another type of obstruction that is of concern to airports serving NLA is that of snowbanks. Though this is a problem primarily encountered at airports during the winter months, it will still require consideration. Current specifications for snow removal, as specified in AC 150/5200-30A, Airport Winter and Safety Operations, require that snowbanks be removed or pushed back to distances so that an aircraft with its main gear on the edge of the runway or taxiway surface will not contact the snow. Figure 16 depicts the current snow removal requirements as recommended in AC 150/5200-30A. NLA dimensions, when compared to this diagram, do not appear to present any direct conflict with current snow removal recommendations. The outer engines of the NLA, however, will be positioned over areas with up to 2 to 3 feet of snow which might be thrown into the air as the aircraft passes.

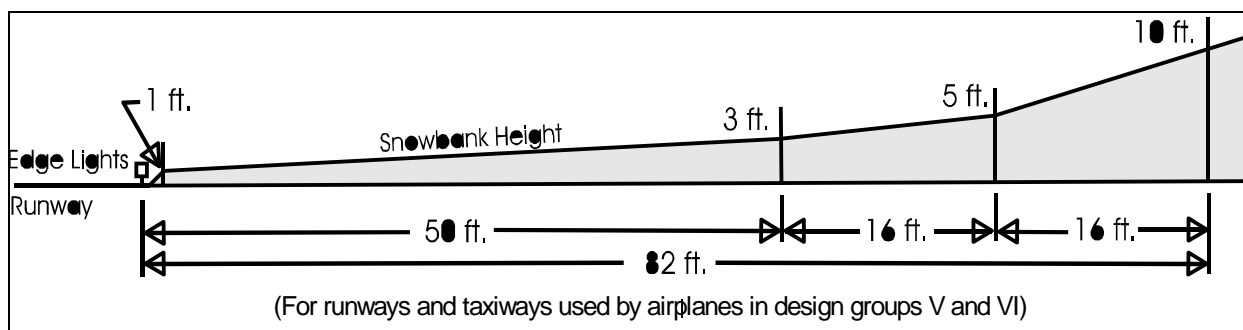

FIGURE 16. SNOW REMOVAL REQUIREMENTS—AC 150/5200-30A

Because of this, it may be appropriate for NLA to shut down their outboard engines while taxiing to prevent possible snow or ice ingestion and also to prevent the blowing of snow into other aircraft or vehicles that are behind the NLA. Operating procedures for landing may also be limited to the use of reverse thrust on the inboard engines only, reducing the amount of turbulence near the wingtips that would blow snow onto or around the runway area. This may of course increase the stopping distance of the aircraft on a runway that may already have reduced friction characteristics. If it is determined that altering the operational procedures for NLA is not feasible, the FAA may need to revise AC 150/5200-30A to include specific guidelines for clearing snow on taxiways or runways that will serve NLA. Requirements that may be incorporated into the revised AC include lower snowbank heights or the requirement to clear all snow within the immediate vicinity of the runway.

AIRSIDE IMPACT—ENVIRONMENTAL ISSUES.

With the introduction of NLA, airports and their surrounding communities are expressing concerns about how the operation of NLA are going to affect the environment. Aircraft manufacturers are well aware of these concerns and are designing NLA to be compatible with today's noise and emission restrictions. This section of the report will address airport environmental issues and show how they might be affected by the introduction of NLA.

AIRPORT NOISE. NLA are currently being designed with new jet engines that produce anywhere from 75,000 to 90,000 pounds of thrust with plans for even larger engines on future derivatives. These engines are being designed to meet today's strict noise limitations.

AC 36-1F, Noise Levels for U.S. Certificated and Foreign Aircraft, contains data on noise levels of existing aircraft. Specifically, it includes the stage level with which the aircraft's noise levels comply. NLA, by current specifications, will meet or be below Stage 3 noise levels. This means that, in effective perceived noise levels (EPNdB), most NLA must be below 106 EPNdB on takeoff (with four engines, over 859,000 lbs. MTOW), 103 EPNdB at sideline (over 882,000 lbs. MTOW), and 105 EPNdB on approach (over 617,300 lbs. maximum landing weight). In comparison with many aircraft in operation today, NLA will be substantially quieter during operations. The HSCT aircraft, in their current configurations, will also meet Stage 3 noise levels during takeoff and approach. They will, however, be flying supersonically during en route segments of flight. The general effects of the noise created by HSCT supersonic flight is under

investigation by Boeing, McDonnell Douglas, and NASA and will be more closely studied as the aircraft comes closer to final design.

Noise levels for U.S. certificated and foreign aircraft currently in operation are, by regulation, to be quantified and included in AC 36-1F. This AC contains data on basic physical and operational characteristics of the aircraft along with their noise levels. The FAA will need to update these data sheets to include noise data on NLA aircraft. With these revisions, both airports and the public will have information available on the effects of NLA noise levels and will also have baselines for future trends in aviation generated noise. AC 36-3G, Estimated Airplane Noise Levels in A-Weighted Decibels, will also require revisions very similar to those of AC 36-1F. This AC provides noise data for various aircraft in estimated A-weighted decibels.

AIR QUALITY. Many airports situated within dense metropolitan areas are very sensitive to pollutants and emissions produced by aircraft. NLA, with their new, high efficiency jet engines, should not produce excessive amounts of pollution. In fact, many manufacturers believe that the NLA will be cleaner than many currently operating aircraft.

WATER RUNOFF. The amount of water runoff at an airport is usually a direct function of the amount of rainfall expected in a typical storm and the amount of pavement on which it is falling. If an airport determines that they will be expanding their facilities to meet the design criteria of the next larger design group, a significant amount of pavement will be added to the airport surface. This increase in paved surface area will present problems for existing water runoff and drainage systems unless provisions are made to compensate for this increase. Larger drainage basins, pipes, retention ponds, and culverts could be needed to meet the demand of the larger amounts of runoff water. The affects of excess water runoff will vary with each airport and will have to be investigated on a case-by-case basis.

LANDSIDE IMPACT.

With their larger passenger capacity, NLA will affect numerous landside issues such as baggage handling, ticket counters, passenger lounges and cueing areas, parking, terminal design, airport capacity, gate compatibility, and various other items. This section identifies these problems, and describes how they might affect current landside design concepts.

GATE REQUIREMENTS. Airports that will serve NLA are most likely to be large, hub airports that currently serve wide-body aircraft. Aircraft gates, the area at which the aircraft is parked, serviced, and loaded, at these large airports will already be designed to handle large aircraft. The presence of wide-body aircraft facilities will simplify the airports task of preparing for NLA.

Terminal gate number, sizes, and locations at large airports are directly related to the forecast number of flights, passengers, and aircraft designs that are expected to utilize them. AC 150/5360-13, Planning and Design Guidelines for Airport Terminal Facilities, discusses the planning process airport designers go through to determine their maximum aircraft/passenger capacity and to forecast the requirements for the future. With this data, airports can then begin expanding their facilities to keep pace with the increase in traffic.

GATE TYPE DETERMINATION. Terminal apron areas are typically designed to handle specific aircraft that fit within certain dimensional criteria. Chapter 4 of AC 150/5360-13 describes the methodology for determining the different gate types. Like the Airport Reference Code (ARC) system that is used to determine the size of airside design criteria, gate types are determined in a very similar manner. The following are the four gate type categories as they appear in AC 150/5360-13.

1. Gate type A. The aircraft using this gate type are those found in airplane design group III with a wingspan between 79 and 118 feet.
2. Gate type B. Airplane design group IV aircraft with a wingspan between 118 and 171 feet and fuselage length less than 160 feet use this gate type.
3. Gate type C. This gate type serves airplane design group IV aircraft with a fuselage length greater than 160 feet.
4. Gate type D. Aircraft in airplane design group V with a wingspan between 171 and 213 feet use this gate type.

When applying this gate type identification system, many NLA do not fit within the dimensional data set forth in the AC. For example, all NLA that are considered design group VI aircraft do not have a gate category. In fact, the B747-400, B777-200 and 300, and both the MD HSCT and the B HSCT are the only aircraft that can be categorized by this system. The FAA will need to update this gate rating system to include a gate type E or develop an alternative method of determining gate sizing.

APRON SEPARATION CLEARANCES. Aircraft parked at a terminal gate are also required to maintain certain separation clearances between themselves and the terminal or other aircraft. Clearance for the nose of the aircraft should be 30 feet for gate type A, 20 feet for gate types B and C, and 15 feet for gate type D. Wingtip to wingtip clearance of two adjacent aircraft should be 15 feet for gate type A and 25 feet for gate types B through D. All aircraft extremities should not be closer than 20 feet to a building for all gate type groups. New gate separation clearances for NLA that are not included in the designated gate type classifications may have to be developed; it is quite possible the gate type D clearance standards will provide sufficient clearance for NLA.

Preliminary calculations to determine the amount of space that will be required to accommodate a NLA at a typical terminal gate indicate that many airports may find it impossible to park a NLA at many existing gate locations. Figure 17 (from AC 150/5360-13) shows the separation standards for an apron area with gate types A through D with both a single and double taxiway. Note that the highest values contained in the table under gate type D represent a B747-400 that is 213 feet long. Dimension standards for aircraft like the NLA are not provided but would be significantly higher than that of the B747-400. Many airports will not have the space available to permit NLA to maneuver between terminal piers as in this example. It appears that the gate positions most likely to be able to handle NLA will be those positioned at the end of a terminal

pier or on a satellite terminal. New clearance standards for terminal apron areas to accommodate NLA will have to be developed. Without them, airports will not have any guidance in providing NLA proper clearance at existing terminals.

PASSENGER LOADING BRIDGES. Most airports that serve larger commercial aircraft utilize passenger loading bridges for the enplaning and deplaning of passengers. The size and operation of the loading bridges vary from airport to airport and sometime even between gates. The actual design of each gate generally depends on the size and type of aircraft they are intended to serve. For example, a bridge servicing a B737 or DC-9 would be lower and smaller than one designed to service a B747. Loading bridge compatibility with NLA is a great concern for airports hoping to serve them in the near future.

Current NLA design trends indicate that the aircraft, despite their large size, will be designed to be compatible with many loading bridges intended to service the B747-400. The door sill heights for many of the NLA peak at 18 feet for the front passenger doors and slowly rise toward the rear of the aircraft. (Door sill heights for all of the NLA discussed in this report appear on the aircraft data sheets in appendix A.) Standard loading bridges should be capable of serving NLA without significant modifications.

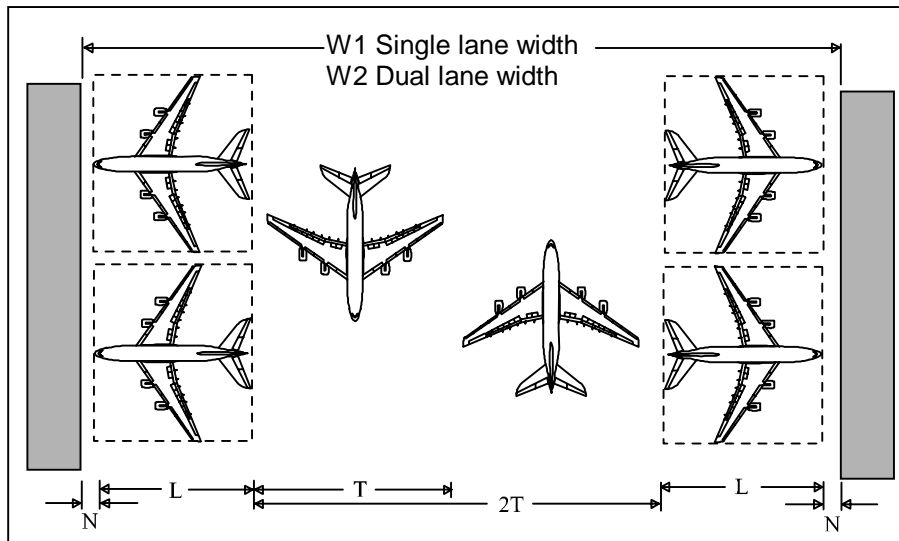

	N	T*	L	W1	W2
Gate Type	Nose to Bldg. Distance	Taxilane OFA Width	Airplane Length	Single Lane Width (2N+T+2L)	Dual Lane Width (2N+2T+2L)
A	30 ft (9 m)	162 ft (49 m)	155 ft (47 m)	532 ft (162 m)	694 ft (212 m)
B	20 ft (6 m)	225 ft (68 m)	160 ft (49 m)	585 ft (179 m)	810 ft (247 m)
C	20 ft (6 m)	225 ft (68 m)	188 ft (57 m)	641 ft (195 m)	866 ft (264 m)
D	15 ft (4.5 m)	276 ft (84 m)	232 ft (71 m)	770 ft (235 m)	1,046 ft (319 m)

*Service roads on aprons are outside of taxilane object area (OFA) and must be accounted for as a separate entity in determining W1 or W2. (See AC 150/5300-13.)

FIGURE 17. TERMINAL APRON DESIGN STANDARDS

It may be feasible to utilize a second loading bridge for loading passengers onto a NLA at airports that are expecting to serve NLA during peak periods of the day. This would increase the flow rate of passengers and also reduce the loading time of the aircraft. This second loading bridge could extend to the midsection of the aircraft, permitting passengers in the rear to bypass passengers loading in the front section of the aircraft. For aircraft such as the A3XX and the B747-500 and 600, it may also be feasible to utilize an additional loading bridge for loading the upper level of the aircraft. This would reduce congestion caused by passengers climbing stairways to the second level. It is not absolutely necessary for airports or the FAA to require additional bridges specially for NLA, as successful boarding can be attained with a standard single loading bridge. The FAA may recommend that future terminal designs incorporate multiple level boarding bridges into their design.

GROUND SERVICING. Specific ground servicing requirements for NLA have not been determined for many of the aircraft, and the requirement will remain fluid until the aircraft goes into final design. Preliminary data indicates that the aircraft will utilize receptacles and equipment very similar to those of wide-body aircraft like the B747-400. Boeing Aircraft Co., in a preliminary airport infrastructure study, indicated that airports may need to supply new aircraft tugs capable of pushing aircraft in excess of 1 million pounds, additional electrical capacity (four 90kVA connections instead of two), increased preconditioned air due to the larger fuselage, and the possibility of modified fueling facilities. (Boeing Presentation to the Port Authority of New York (PANY), 9/16/96). Other NLA will most likely have very similar ground servicing requirements as those predicted by Boeing. The FAA may consider revising AC 150/5360-13 to include recommendations for meeting equipment requirements of NLA. These revisions might also be accomplished through the modification of airport equipment specifications.

LANDSIDE IMPACT—TERMINAL DESIGN.

The airport terminal is perhaps the most complex element of the overall airport design that will require modification for NLA operations. The introduction of NLA at large airports currently capable of handling wide-body aircraft will create minimal, yet still noticeable, increases in passenger congestion. The full impact of a NLA arrival or departure will be lessened by the airport terminal's capability to handle large surges of passengers associated with the loading and unloading of a large aircraft. There will, however, be other areas of terminal design that will exceed their designed maximum limits and require some improvements or expansions. NLA will be carrying up to 100 more passengers than a traditional wide-body aircraft, and all will need to be processed in the same amount of space and time as those on today's aircraft.

The majority of flights conducted by NLA will be international and/or long route flights. This suggests that the flights will have passenger load characteristics similar to those of today's international flights. Airports can expect the ratios of leisure to business travelers, number of visitors, baggage levels, and parking requirements will be comparable to those of current flights. These ratios and requirement estimates are discussed in great detail in AC 150/5360-13.

TICKETING LOBBIES. Existing ticketing lobbies can expect an increase in the number of passengers requiring service prior to the departure of an NLA. This larger passenger traffic will

require ticket counters and lobbies to process the passengers without creating long lines of passengers in the cueing area. Future demands for larger ticketing lobbies should be considered as NLA flights become more common. Current FAA design standards in AC 150/5360-13 should still provide the proper guidance for airports to design ticketing lobbies but may require an increase in the amount of counter frontage, queuing space in front of the counter, and space for the movement of passengers around the queuing area as NLA operations continue to increase.

WAITING LOBBIES. Passenger waiting lobbies, which generally include public seating and access to passenger amenities, will also be affected by NLA flights. Up to 100 additional passengers, plus an average of one visitor per passenger, will be utilizing these facilities while waiting for a single NLA flight. It may be feasible for airports to add additional seats or facilities in these areas to accommodate the increase in passengers and visitors, providing sufficient space exists. These requirements change from airport to airport and should be researched on a case-by-case basis.

BAGGAGE LOBBIES. The number of passengers waiting to collect their baggage at a baggage claim facility will also increase in proportion to the size of the aircraft. A typical arrival of a single Airbus A3XX-100 with 555 passengers will produce over 1,000 people at the airport for a single aircraft arrival. The majority of these people will be traveling from the gate to the baggage claim area. This mass of people, in addition to the increased number of bags, will require substantially more room than provided in the traditional baggage claim area. The FAA's current design standards for baggage lobbies should be sufficient, so long as airports have the available space to expand and meet these requirements.

PUBLIC CORRIDORS. Passengers and the visitors that are arriving on or waiting for a NLA flight will be circulating between the ticket counters, gates, and baggage claim areas. Public corridors must be designed to accommodate the mass flow of people associated with a flight arrival or departure. Obstructions such as pay telephones, flight information displays, or restroom entrances/exits that might slow or block passengers in the corridors should be removed, or at least minimized, to provide the maximum amount of space for passenger flow. AC 150/5360-13 provides an example that shows how a 20-foot-wide corridor (obstacle free) with a 2.5-foot-wide by 4- to 6-foot long pedestrian occupancy space can accommodate 330-484 pedestrians a minute. Airports should consider current corridor capacities and possibly plan modifications such as the removal of obstacles that reduce the effective width of corridors. Another approach might be to limit the rate of passenger deplanements to avoid congestion in corridors, escalators, etc.

SECURITY INSPECTION STATIONS. Airport security inspection stations, in today's world, have become one of the most important elements of an airport terminal. All passengers and visitors (if allowed into the gate area) are required by federal regulations to pass through a security checkpoint in which they are screened for weapons or other dangerous devices. Because NLA flights are international in nature, it is most important that NLA passengers are screened properly without any safety compromise. Airports may be required to expand their security stations to facilitate the increased number of passengers. This could be done by installing additional walk-through weapons detectors and x-ray machines. Without modifications, airports

may find that security checkpoints will create bottlenecks for passengers trying to make their way from the general terminal area to the proper aircraft gate. The FAA will need to assure that airports can properly conduct the passenger screening procedures in the quickest, most efficient manner. This area may require additional research.

DEPARTURE LOUNGES. Departure lounges at airports are the areas where passengers wait immediately before boarding the aircraft. For NLA departures involving aircraft such as the Airbus A3XX-100, approximately 555 passengers plus their carry-on baggage and their visitors will need to be accommodated in these departure lounges during preparation for boarding. In addition, there must be room for the agent desks where passengers can check-in, verify seat assignments, or address any other problems before boarding the aircraft. Proper space must also be available for passengers to queue during boarding. If multiple boarding bridges are available for passengers, proper space must be available for these queue areas also. AC 150/5360-13 provides information on estimating the size of departure lounge areas on the basis of aircraft seating capacity. This information is shown in table 9. Note that the maximum seating capacity accounted for in this table is 420 passengers. The FAA will need to revise this chart to include seating capacities equal to those of the largest NLA. It is very likely that airports will be unable to provide increased space requirements indicated by these revisions and may need to develop other ways of increasing the space available for this purpose. Solutions for this problem may include the use of adjacent gate positions during periods of inactivity or the addition of a second floor on the gate area to permit two tier queuing and loading.

TABLE 9. DEPARTURE LOUNGE AREA SPACE REQUIREMENTS

Aircraft Seating Capacity	Departure Lounge Area Square Feet (Square Meters)		
	Boarding Load Factors		
	35-45 percent	55-65 percent	75-85 percent
Up to 80	350 (33)	515 (48)	675 (63)
81 to 110	600 (56)	880 (79)	1,110 (102)
111 to 160	850 (79)	1,175 (109)	1,500 (139)
161 to 220	1,200 (111)	1,600 (149)	2,000 (186)
221 to 280	1,500 (139)	2,000 (186)	2,500 (232)
281 to 420	2,200 (204)	3,000 (279)	3,800 (353)

(Source: FAA AC 150/5360-13)

PARKING FACILITIES. Airport parking facilities may also be affected by the introduction of NLA because of the increased number of passengers that will be transported on a single flight. AC 150/5360-13 discusses guidelines for designing airport facilities to properly handle the number of passengers flying in and out of the airport. The AC states that 40 to 85 percent of the passengers using the airport bring their own private automobiles. This figure, of course, varies greatly with the location of the airport. By using the rules of thumb provided in the AC for determining the number of parking spaces required, a single NLA arrival will require an estimated 150 parking spaces more than the number currently recommended. This figure is based on a 1.5 parking spaces per peak hour passenger, multiplied by the additional 100 passengers a NLA will carry as compared to a typical wide-body jet. In addition, an estimated 15

percent more spaces should be added to eliminate the need for drivers to search for available parking spots. This would require an additional 173 parking spaces to accommodate the additional peak hour passenger arrival/departures of a NLA flight. In the future, it is anticipated that many airports will host two to three NLA per day. Should more than one NLA arrive or depart around the same time, parking facilities will more than likely be full and require additional remote parking areas. This may not be a significant problem for passengers, as most that travel on NLA flights will be away for an extended period of time, as is common with international travel, and will not require onsite parking. The FAA will need to verify the accuracy of these design standards and be aware that airports may require these additional parking facilities.

LANDSIDE ISSUES—BAGGAGE HANDLING.

From the flying public's point of view, baggage claim facilities are the biggest problem encountered during a typical trip. Very frequently passengers find themselves missing bags or waiting for long periods for their bags to appear on the baggage carousel. Current baggage handling facilities at large airports are expected to handle NLA baggage loads in the same manner as they handle those of current aircraft, despite the significant increase in the number of pieces. Passengers traveling on a typical commercial aircraft are estimated to carry 1.3 bags per person. This calculation is based on the assumption that business travelers will have less to carry and that vacationers will have more. A NLA with 555 passengers will produce approximately 722 bags per flight that will need to be sorted and forwarded to the appropriate locations. Typical baggage conveyor belts that move the baggage between locations are capable of handling 26 to 50 bags per minute, according to AC 150/5360-13. At this rate, it would take up to 14.5 minutes for all of the bags on a A3XX-100 to be moved by a conveyor belt. This assumes the belt is running full speed, there are no problems, and that the bags were placed on the belt continuously.

It is anticipated that new technology will bring faster, more efficient baggage handling equipment that will be able to process NLA baggage in less time than at present. The futuristic baggage facility at the new Denver International Airport serves as an example of this concept. Without the development of new baggage facilities, airports may have major problems accommodating all of the baggage associated with the arrival and departure of a NLA.

COSTS FOR INTRODUCING NEW LARGE AIRCRAFT

Airports in the United States will require significant facility improvements to handle the large aircraft. The majority of these changes are needed to meet the design group characteristics of the largest aircraft. In this case, airports will be upgrading to meet design group VI for most NLA. Although this sounds like a simple process, it will involve millions of dollars in construction and improvement activity.

It is anticipated that airports expecting to serve NLA will be those that are already serving international bound wide-body aircraft like the B747-400, the Lockheed L-1011, or the MD-11. Aircraft manufacturers are targeting the aircraft to specific international city pair routes that the larger airlines are currently serving with wide-body aircraft. Route segments ending at large

airports such as John F. Kennedy International Airport (JFK) or Los Angeles International Airport (LAX) are very likely candidates.

It is most important to remember that most NLA will be considered design group VI aircraft and will require the separation standards and other operational limitations that are associated with this design group. Airports that do not meet the requirements of design group VI will all require the appropriate modifications and improvements necessary to meet the design group's criteria. Airports currently serving the B747-400 should be easiest to upgrade because, at design group V, they are already close to meeting the criteria for NLA. The process will still require significant amounts of costly construction.

Table 10 contains a list of airports that currently serve the Boeing 747. Each of these airports has available facilities to meet the design group criteria of group V (B747) but do not necessarily meet the requirements of design group VI. In various briefings and press releases, Airbus Industries has indicated that they are hoping to serve nine of the airports listed in table 10 with the A3XX. These airports include Anchorage, Chicago, Newark, Honolulu, Los Angeles, JFK, Miami, Memphis, and San Francisco.

Aircraft manufacturers are primarily focusing on a few airports for initial operations because of the significant modifications that will be required at these airports. The bulk of NLA traffic will most likely be on densely traveled, long-haul routes terminating in major cities such as London, Paris, Frankfurt, or Hong Kong. Foreign airports appear to be compatible to the NLA because the International Civil Aviation Organization (ICAO) -defined airport design system used overseas requires design standards that accommodate NLA.

To assess the adequacy of each airport for airside separations to serve NLA would require significant investigation and research that is beyond the scope of this report. It is obvious, however, that each will require modifications if they do not meet the design group criteria for the specific NLA that will be operating at their airport. Each airport will have to assess the current facilities and conditions to determine the amount of work needed. Basic enhancements such as runway or taxiway widening, fillet addition, or pavement strengthening may be required for these airports to support NLA. Alternatively, the FAA may issue operational waivers to permit NLA operation with less than recommended separation standards. The FAA will have to determine the possible effects these waivers will have on airport safety before choosing this course of action.

The Port Authority of New York and New Jersey (PANYNJ) recently concluded an investigation into the estimated cost of modifying their JFK International Airport to accommodate NLA. The report concluded that with all of the appropriate modifications required to upgrade JFK International Airport to design group VI, it would cost approximately \$236 million dollars (PANYNJ NLA Study, 1994). This figure includes the widening of runways and taxiways, extension of a runway, and the strengthening of several pavement surfaces (runways, taxiways, culverts, etc.). An alternative plan, which assumes that not all runways and taxiways will have to be widened, could be done for \$106 million. This includes the addition of taxiway fillets

TABLE 10. AIRPORTS CURRENTLY SERVING THE BOEING 747

Airport ID	Airport Name
ANC	Anchorage International
ATL	Atlanta Hartsfield International
BDL	Bradley International
BNA	Nashville International
BOS	Logan International
CLT	Charlotte/Douglas International
DAY	Dayton International
DEN	Denver International
DFW	Dallas/Fort Worth International
DTW	Detroit Metropolitan Wayne County
EWR	Newark International
HNL	Honolulu International
IAD	Washington Dulles International
IAH	Houston Intercontinental
IND	Indianapolis International
JFK	John F. Kennedy International
KOA	Keahole-Kona International
LAS	McCarran International
LAX	Los Angeles International
MCI	Kansas City International
MCO	Orlando International
MEM	Memphis International
MIA	Miami International
MSP	Minneapolis-St. Paul International
OAK	Metropolitan Oakland International
ONT	Ontario International
ORD	Chicago O'Hare International
PDX	Portland International
PHL	Philadelphia International
PHX	Phoenix Sky Harbor International
PIT	Greater Pittsburgh International
SAN	San Diego International-Lindbergh Field
SDF	Louisville-Standiford Field
SEA	Seattle-Tacoma International
SFO	San Francisco International
SJC	San Jose International
SLC	Salt Lake City International

the extension of one runway, and the strengthening of same pavement surfaces mentioned in the first example. Other costs, in addition to those previously stated, that were included in this study were for reconstruction of taxiway bridges (\$10 million), addition of a rooftop holding room at the end of two terminal fingers, additional loading bridges (\$6 million), and the requirement for more ARFF equipment and facilities (\$1 million). In total, it would cost the PANYNJ between \$125 to \$250 million dollars to meet the NLA requirements at JFK (PANYNJ NLA Study, 1994). These figures were estimated in 1994 and are assumed to be higher in today's dollar.

It is most important that the FAA consider the cost effectiveness of requiring airports to modify their facilities to meet the design group criteria of these aircraft. It is very unlikely that the increase in passenger or traffic volume with NLA will be sufficient to recover the costs associated with the design group upgrade. For this reason, airports will be looking to the FAA to minimize development and to assist in funding the upgrade. The FAA has recognized the requirement for providing local communities with guidance in developing cost estimates for new facilities or improvements and is conducting a study to develop a comprehensive guide for estimating the costs of major airport development projects.

CONCLUSIONS

1. The introduction of NLA, for many airports, will involve significant modifications to accommodate the size and weight of the new aircraft. Most NLA will be design group VI aircraft and will require, at a minimum, the type of facilities mandated in the appropriate Advisory Circulars for those design groups. In the United States, there are very few airports that will be able to serve NLA without significant modifications.
2. Certain airport design standards and the Advisory Circulars containing them will require many changes. Some of these changes will be simple additions, while others will require deeper study. The design standards that will require revisions have been identified in this report.
3. The FAA's aircraft design group VI, intended to accommodate the next generation of aircraft, generally meets the requirements of NLA.
4. Current FAA design standards, which use wingspan as the basis for most airports, do not address the needs of long-fuselage aircraft. Aircraft such as the HSCT should not be categorized with aircraft like the B757. A new design group categorization may be required to include dimensional data like weight, height, or wheelbase in addition to the stall speed and wingspan.
5. Airport design issues such as those mentioned in this report will need to be resolved in a timely manner because airports are going to require guidance on this subject as soon as possible. Basic airport construction projects can take up to 8 to 10 years to complete, depending on the number and complexity of environmental, funding, and operational problems that are encountered. NLA introductions are expected to occur in the next 2 to 3 years, and for this reason, actions must be taken immediately.

6. Many airports across the country, particularly the Port Authority of New York and New Jersey, are expressing concern over the introduction of NLA. Airports fear that they will be unable to complete the required modifications before the arrival of the aircraft. Open communications between airlines, airports, aircraft manufacturers, and the FAA must be established to aid in addressing these concerns.
7. Several airports that are considering the introduction of NLA do not have land available to meet the design requirements of aircraft group VI. Airports falling into this category are going to require either operational waivers or else be restricted in or prohibited from operating the NLA aircraft. This will require significant investigation by the FAA to determine the extent to which these aircraft can operate in an environment that does not meet design standards.
8. Items such as ARFF requirements, evacuation procedures, and operational limitations are all regulatory in nature and will require careful review. New subjects such as second deck accessibility on double-deck aircraft need to be considered. These regulatory items fall outside of the scope of this effort and were only briefly touched upon in this report.

RECOMMENDATIONS

As a result of this study and the conclusions reached, we recommend the following:

1. An action team should be formed to incorporate all necessary changes into the pertinent FAA regulations, orders, Advisory Circulars, and other documents. Team members should be drawn from the ranks of organizations intimately involved in day-to-day activities within each technical arena (i.e., pavement design and construction, firefighting, terminal design, etc.)
2. The team should be constituted so that the members will, after due consideration, not only make recommendations for necessary changes but will also have the authority to implement the changes in a timely manner.
3. Factors that determine design group, criteria, and concepts such as vertical separation versus horizontal separation might be re-evaluated to eliminate the need to increase taxiway/taxiway separation or the relocation of loading gates. Many NLA will sit higher above the pavement than other smaller aircraft, permitting aircraft wingtips to overlap. Other concepts like equivalent safety could be introduced; supplemental safety items like ground looking camera systems, wingtip collision indicators, or reduced speed limits for NLA could be introduced to compensate for reduced separation clearances.
4. Open lines of communication with airports that are considering the introduction of NLA, the aircraft manufacturers, and airlines should be established. By exchanging information and concerns between the four parties, the introduction of NLA can be approached as a team effort rather than as individuals. This will eliminate any duplication of effort and will lead to expedient results.

REFERENCES

AC 36-1F, Noise Levels for U.S. Certificated and Foreign Aircraft, Federal Aviation Administration, 6/5/92.

AC 36-3G, Estimated Airplane Noise Levels in A-Weighted Decibels, Federal Aviation Administration, 4/2/96.

AC 120-58, Pilot Guide—Large Aircraft Ground Deicing, Federal Aviation Administration, 9/30/92.

AC 150/5200-30A, Airport Winter and Safety Operations, Federal Aviation Administration, 10/1/91.

AC 150/5200-31, Airport Emergency Plan, Federal Aviation Administration, 1/27/89.

AC 150/5210-2A, Airport Emergency Medical Facilities and Services, Federal Aviation Administration, 11/27/84.

AC 150/5210-6C, Aircraft Fire and Rescue Facilities and Extinguishing Agents, Federal Aviation Administration, 1/28/85.

AC 150/5220-17A, Design Standards for an Aircraft Rescue and Firefighting Training Facility, Federal Aviation Administration, 1/31/92.

AC 150/5300-13, Airport Design, Federal Aviation Administration, 9/29/89, with Changes 1 through 4.

AC 150/5300-14, Design of Aircraft Deicing Facilities, Federal Aviation Administration, 8/23/93.

AC 150/5320-5B, Airport Drainage, Federal Aviation Administration, 7/1/70.

AC 150/5320-6D, Airport Pavement Design and Evaluation, Federal Aviation Administration, 7/7/95.

AC 150/5320-16, Airport Pavement Design for the Boeing 777 Airplane, Federal Aviation Administration, 10/22/95.

AC 150/5325-4A, Runway Length Requirements for Airport Design, Federal Aviation Administration, 1/29/90, with Change 1 dated 3/11/91.

AC 150/5340-18C, Standards for Airport Sign Systems, Federal Aviation Administration, 7/31/91.

AC 150/5360-13, Planning and Design Guidelines for Airport Terminal Facilities, Federal Aviation Administration, 4/22/88.

Preliminary Report on the Impacts of the New Large Airplane (NLA) on Kennedy and Newark International Airports, Port Authority of New York and New Jersey Aviation Department, January 14, 1994.

Presentation by Boeing Aircraft Corporation at the Port Authority of New York and New Jersey, John F. Kennedy International Airport, 9/16/96.

**APPENDIX A—AIRCRAFT DATA SHEETS AND AIRPORT DESIGN CRITERIA
DATA SHEETS**

AIRBUS A3XX-100

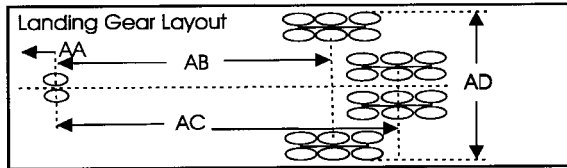
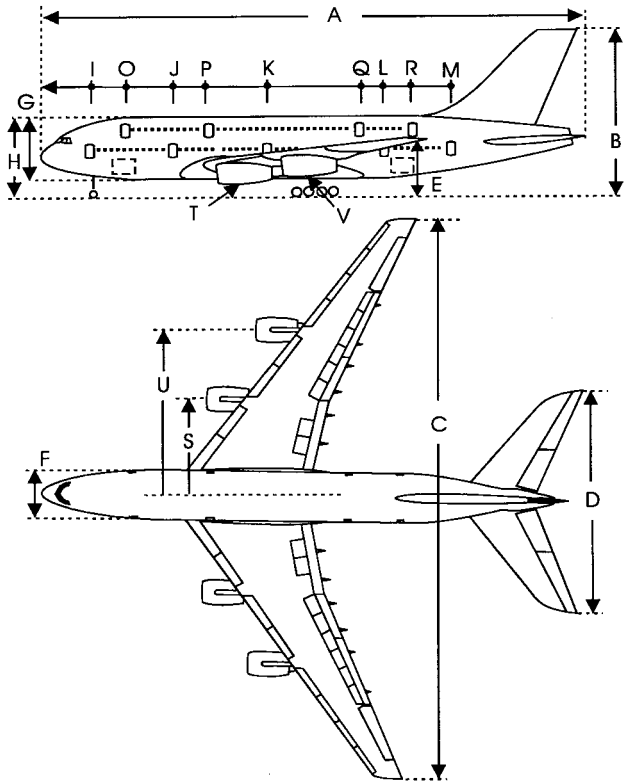

QUICK REFERENCE	
Wingspan:	259' 2"
Length:	232' 4"
Height:	79' 8"
Passenger Capacity:	555
Maximum Takeoff Weight:	1,124,357
Airport Reference Code (ARC):	D-VI

General Dimensions:		
A	Length (Overall)	232 4
B	Height (Overall)	79 8
C	Wingspan	259 2
D	Tailspan	103 4
E	Wing Tip Ground Clearance	29 2
Fuselage Dimensions:		
F	Fuselage Width	22 10
G	Fuselage Height	27 9
H	Top of Fuselage to Ground	- -
Door Sill Heights:		
	1st Passenger Door	17 4
	2nd Passenger Door	17 4
	3rd Passenger Door	17 5
	4th Passenger Door	17 6
	5th Passenger Door	17 6
	6th Passenger Door	- -
	2nd Level, 1st Pass. Door	26 6
	2nd Level, 2nd Pass. Door	26 6
	2nd Level, 3rd Pass. Door	26 7
	2nd Level, 4th Pass. Door	26 7
Landing Gear Dimensions:		
AA	Nose to Nose Gear Post	17 1
AB	Nose Gear Post to Forward Main Gear Post	88 11
AC	Nose Gear Post to Rearward Main Gear Post	98 5
AD	Maximum Main Gear Width (Outside Tire Edge)	50 8
Door Locations:		
T	1st Passenger Door	20 4
J	2nd Passenger Door	49 2
K	3rd Passenger Door	88 3
L	4th Passenger Door	208 1
M	5th Passenger Door	172 9
N	6th Passenger Door	- -
O	2nd Level, 1st Pass. Door	34 8
P	2nd Level, 2nd Pass. Door	64 5
Q	2nd Level, 3rd Pass. Door	127 4
R	2nd Level, 4th Pass. Door	157 7
Engine Dimensions:		
S	Engine to Centerline (In)	44 6
T	Ground Clearance (In)	4 1
U	Engine to Centerline (Out)	77 1
V	Ground Clearance (Out)	8 1

General Specifications:	
Passenger Capacity	555
Cargo Capacity (Lbs.)	187,000
Fuel Capacity (Lbs.)	705,000
Empty Weight (Lbs.)	575,406
Max Takeoff Weight (Lbs.)	1,124,357
Max Landing Weight (Lbs.)	831,142
Runway Length Required (Ft.)	11,000
Service Turn-Around Time (Min.)	120
Approach Speed (Knots)	150
Takeoff Speed (Knots)	-
Pavement Required for 180 Degree Turn (Ft.)	197
Turning Radius of Nose Gear (Ft.)	170
Wingtip Clearance Radii (Ft)	-
Noise Level (Stage Level)	Below 3
Number of Engines	4
Maximum Thrust Per Engine	72,000

AIRBUS A3XX-100
AIRPORT DESIGN AIRPLANE AND AIRPORT DATA

Aircraft Approach Category D or E	
Airplane Design Group VI	
Airplane wingspan	259.20 feet
Primary runway end approach visibility minimums are lower than CAT I	
Other runway end approach visibility minimums are lower than CAT I	
Airplane undercarriage width (1.15 x main gear track)	50.70 feet
Airport elevation	100 feet
Airplane tail height	79.70 feet

RUNWAY AND TAXIWAY WIDTH AND CLEARANCE STANDARD DIMENSIONS

Airplane Group/ARC

Runway centerline to parallel runway centerline simultaneous operations
when wake turbulence is not treated as a factor:

VFR operations with no intervening taxiway	700 feet
VFR operations with one intervening taxiway	1200 feet
VFR operations with two intervening taxiways	1524 feet
IFR approach and departure with approach to near threshold	2500 feet less
100 ft for each 500 ft of threshold stagger to a minimum of 1000 feet.	

Runway centerline to parallel runway centerline simultaneous operations
when wake turbulence is treated as a factor:

VFR operations	2500 feet
IFR departures	2500 feet
IFR approach and departure with approach to near threshold	2500 feet
IFR approach and departure with approach to far threshold	2500 feet plus
100 feet for each 500 feet of threshold stagger.	
IFR approaches	3400 feet
Runway centerline to parallel taxiway/taxilane centerline	503.0 600 feet
Runway centerline to edge of aircraft parking	503.0 505 feet
Runway width	200 feet
Runway shoulder width	40 feet
Runway blast pad width	280 feet
Runway blast pad length	400 feet
Runway safety area width	500 feet
Runway safety area length beyond each runway end or stopway end, whichever is greater	1000 feet
Runway object free area width	800 feet
Runway object free area length beyond each runway end or stopway end, whichever is greater	1000 feet
Clearway width	500 feet
Stopway width	200 feet

Obstacle free zone (OFZ):

Runway OFZ width	400 feet
Runway OFZ length beyond each runway end	200 feet
Inner-approach OFZ width	400 feet
Inner-approach OFZ length beyond approach light system	200 feet
Inner-approach OFZ slope from 200 feet beyond threshold	50:1
Inner-transitional OFZ height H	19.1 18.7 feet

Inner-transitional OFZ slope out to distance Y	5:1
Inner-transitional OFZ distance Y from runway centerline 718.0	721 feet
Inner-transitional OFZ slope beyond distance Y	6:1

Runway protection zone at the primary runway end:

Width 200 feet from runway end	1000 feet
Width 2700 feet from runway end	1750 feet
Length	2500 feet

Runway protection zone at other runway end:

Width 200 feet from runway end	1000 feet
Width 2700 feet from runway end	1750 feet
Length	2500 feet

Departure runway protection zone:

Width 200 feet from the far end of TORA	500 feet
Width 1900 feet from the far end of TORA	1010 feet
Length	1700 feet

Threshold surface at primary runway end:

Distance out from threshold to start of surface	200 feet
Width of surface at start of trapezoidal section	1000 feet
Width of surface at end of trapezoidal section	4000 feet
Length of trapezoidal section	10000 feet
Length of rectangular section	0 feet
Slope of surface	34:1

Threshold surface at other runway end:

Distance out from threshold to start of surface	200 feet
Width of surface at start of trapezoidal section	1000 feet
Width of surface at end of trapezoidal section	4000 feet
Length of trapezoidal section	10000 feet
Length of rectangular section	0 feet
Slope of surface	34:1

Taxiway centerline to parallel taxiway/taxilane centerline 321.0	324 feet
Taxiway centerline to fixed or movable object 191.4	193 feet
Taxilane centerline to parallel taxilane centerline 295.1	298 feet
Taxilane centerline to fixed or movable object 165.5	167 feet
Taxiway width 90.8	100 feet
Taxiway shoulder width	40 feet
Taxiway safety area width 259.2	262 feet
Taxiway object free area width 382.8	386 feet
Taxilane object free area width 331.0	334 feet
Taxiway edge safety margin	20 feet
Taxiway wingtip clearance 61.8	62 feet
Taxilane wingtip clearance 35.9	36 feet

REFERENCE: AC 150/5300-13, Airport Design, including Changes 1 through 4.

AIRBUS A3XX-200

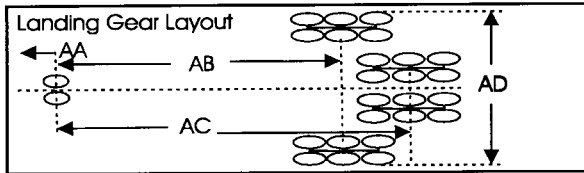
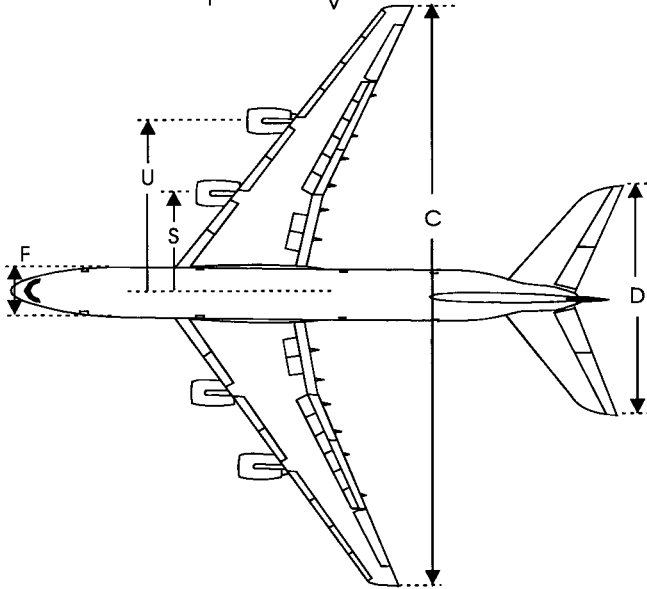
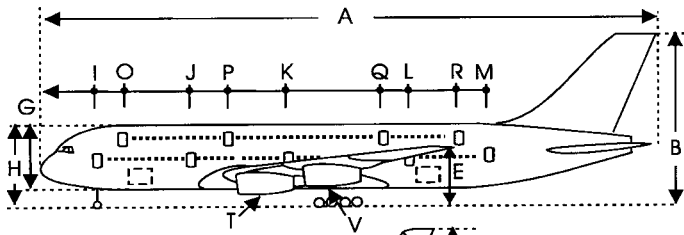

QUICK REFERENCE

Wingspan:	259' 2"
Length:	254'
Height:	79' 8"
Passenger Capacity:	656
Maximum Takeoff Weight:	1,212,542
Airport Reference Code (ARC):	D-VI

General Dimensions:			
A	Length (Overall)	254	0
B	Height (Overall)	79	8
C	Wingspan	259	2
D	Tailspan	103	4
E	Wing Tip Ground Clearance	29	2
Fuselage Dimensions:			
F	Fuselage Width	22	10
G	Fuselage Height	27	9
H	Top of Fuselage to Ground	-	-
Door Sill Heights:			
	1st Passenger Door	17	4
	2nd Passenger Door	17	4
	3rd Passenger Door	17	5
	4th Passenger Door	17	6
	5th Passenger Door	17	6
	6th Passenger Door	-	-
	2nd Level, 1st Pass. Door	26	6
	2nd Level, 2nd Pass. Door	26	6
	2nd Level, 3rd Pass. Door	26	7
	2nd Level, 4th Pass. Door	26	7
Landing Gear Dimensions:			
AA	Nose to Nose Gear Post	17	1
AB	Nose Gear Post to Forward Main Gear Post	-	-
AC	Nose Gear Post to Rearward Main Gear Post	-	-
AD	Maximum Main Gear Width (Outside Tire Edge)	50	8
Door Locations:			
I	1st Passenger Door	20	4
J	2nd Passenger Door	-	-
K	3rd Passenger Door	-	-
L	4th Passenger Door	-	-
M	5th Passenger Door	-	-
N	6th Passenger Door	-	-
O	2nd Level, 1st Pass. Door	34	8
P	2nd Level, 2nd Pass. Door	-	-
Q	2nd Level, 3rd Pass. Door	-	-
R	2nd Level, 4th Pass. Door	-	-
Engine Dimensions:			
S	Engine to Centerline (In)	44	6
T	Ground Clearance (In)	4	1
U	Engine to Centerline (Out)	77	1
V	Ground Clearance (Out)	8	1

General Specifications:	
Passenger Capacity	656
Cargo Capacity (Lbs.)	209,000
Fuel Capacity (Lbs.)	705,000
Empty Weight (Lbs.)	624,000
Max Takeoff Weight (Lbs.)	1,212,542
Max Landing Weight (Lbs.)	890,667
Runway Length Required (Ft.)	11,000
Service Turn-Around Time (Min.)	120
Approach Speed (Knots)	150
Takeoff Speed (Knots)	-
Pavement Required for 180 Degree Turn (Ft.)	197
Turning Radius of Nose Gear (Ft.)	184
Wingtip Clearance Radii (Ft)	-
Noise Level (Stage Level)	Below 3
Number of Engines	4
Maximum Thrust Per Engine	78,000

AIRBUS A3XX-200
AIRPORT DESIGN AIRPLANE AND AIRPORT DATA

Aircraft Approach Category D or E	
Airplane Design Group VI	
Airplane wingspan	259.20 feet
Primary runway end approach visibility minimums are lower than CAT I	
Other runway end approach visibility minimums are lower than CAT I	
Airplane undercarriage width (1.15 x main gear track) . . .	50.70 feet
Airport elevation	100 feet
Airplane tail height	79.70 feet

RUNWAY AND TAXIWAY WIDTH AND CLEARANCE STANDARD DIMENSIONS

Airplane Group/ARC

Runway centerline to parallel runway centerline simultaneous operations
when wake turbulence is not treated as a factor:

VFR operations with no intervening taxiway	700 feet
VFR operations with one intervening taxiway	1200 feet
VFR operations with two intervening taxiways	1524 feet
IFR approach and departure with approach to near threshold	2500 feet less
100 ft for each 500 ft of threshold stagger to a minimum of 1000 feet.	

Runway centerline to parallel runway centerline simultaneous operations
when wake turbulence is treated as a factor:

VFR operations	2500 feet
IFR departures	2500 feet
IFR approach and departure with approach to near threshold . .	2500 feet
IFR approach and departure with approach to far threshold	2500 feet plus
100 feet for each 500 feet of threshold stagger.	
IFR approaches	3400 feet

Runway centerline to parallel taxiway/taxilane centerline .	503.0	600 feet
Runway centerline to edge of aircraft parking	503.0	505 feet
Runway width		200 feet
Runway shoulder width		40 feet
Runway blast pad width		280 feet
Runway blast pad length		400 feet
Runway safety area width		500 feet
Runway safety area length beyond each runway end		
or stopway end, whichever is greater		1000 feet
Runway object free area width		800 feet
Runway object free area length beyond each runway end		
or stopway end, whichever is greater		1000 feet
Clearway width		500 feet
Stopway width		200 feet

Obstacle free zone (OFZ):

Runway OFZ width	400 feet
Runway OFZ length beyond each runway end	200 feet
Inner-approach OFZ width	400 feet
Inner-approach OFZ length beyond approach light system	200 feet
Inner-approach OFZ slope from 200 feet beyond threshold . . .	50:1
Inner-transitional OFZ height H	19.1 18.7 feet

Inner-transitional OFZ slope out to distance Y	5:1
Inner-transitional OFZ distance Y from runway centerline 718.0	721 feet
Inner-transitional OFZ slope beyond distance Y	6:1

Runway protection zone at the primary runway end:

Width 200 feet from runway end	1000 feet
Width 2700 feet from runway end	1750 feet
Length	2500 feet

Runway protection zone at other runway end:

Width 200 feet from runway end	1000 feet
Width 2700 feet from runway end	1750 feet
Length	2500 feet

Departure runway protection zone:

Width 200 feet from the far end of TORA	500 feet
Width 1900 feet from the far end of TORA	1010 feet
Length	1700 feet

Threshold surface at primary runway end:

Distance out from threshold to start of surface	200 feet
Width of surface at start of trapezoidal section	1000 feet
Width of surface at end of trapezoidal section	4000 feet
Length of trapezoidal section	10000 feet
Length of rectangular section	0 feet
Slope of surface	34:1

Threshold surface at other runway end:

Distance out from threshold to start of surface	200 feet
Width of surface at start of trapezoidal section	1000 feet
Width of surface at end of trapezoidal section	4000 feet
Length of trapezoidal section	10000 feet
Length of rectangular section	0 feet
Slope of surface	34:1

Taxiway centerline to parallel taxiway/taxilane centerline	321.0	324 feet
Taxiway centerline to fixed or movable object	191.4	193 feet
Taxilane centerline to parallel taxilane centerline	295.1	298 feet
Taxilane centerline to fixed or movable object	165.5	167 feet
Taxiway width	90.8	100 feet
Taxiway shoulder width		40 feet
Taxiway safety area width	259.2	262 feet
Taxiway object free area width	382.8	386 feet
Taxilane object free area width	331.0	334 feet
Taxiway edge safety margin		20 feet
Taxiway wingtip clearance	61.8	62 feet
Taxilane wingtip clearance	35.9	36 feet

REFERENCE: AC 150/5300-13, Airport Design, including Changes 1 through 4.

BOEING 747-400

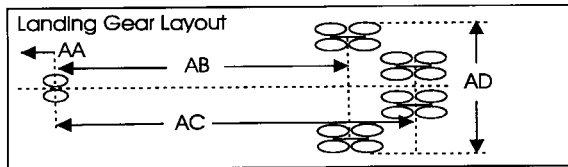
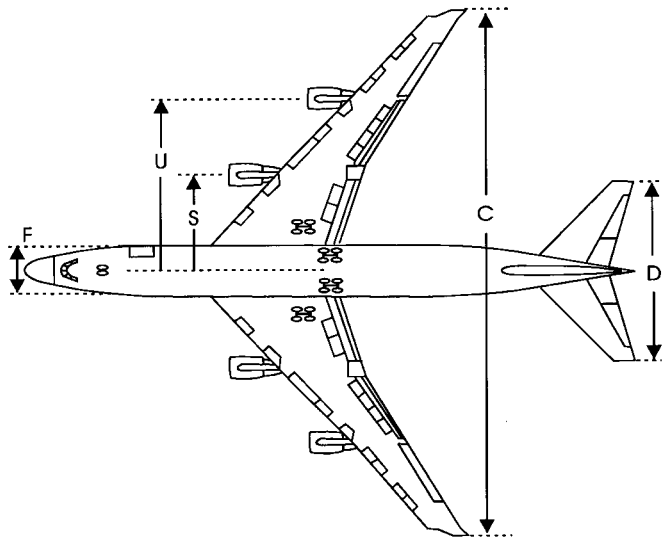
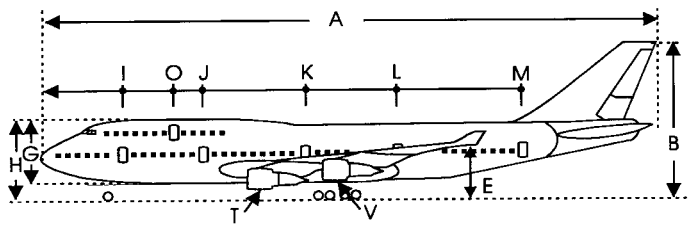

QUICK REFERENCE	
Wingspan:	213'
Length:	231' 10"
Height:	63' 8"
Passenger Capacity:	400
Maximum Takeoff Weight:	875,000
Airport Reference Code (ARC):	D-V

General Dimensions:		
	Feet	Inches
A Length (Overall)	231	10
B Height (Overall)	63	8
C Wingspan	213	0
D Tailspan	72	9
E Wing Tip Ground Clearance	17	9

Fuselage Dimensions:		
	Feet	Inches
F Fuselage Width	21	4
G Fuselage Height	25	5
H Top of Fuselage to Ground	32	10
Door Sill Heights:		
1st Passenger Door	16	2
2nd Passenger Door	16	4
3rd Passenger Door	16	6
4th Passenger Door	16	6
5th Passenger Door	16	8
6th Passenger Door	-	-
2nd Level, 1st Pass. Door	25	4
2nd Level, 2nd Pass. Door	-	-
2nd Level, 3rd Pass. Door	-	-
2nd Level, 4th Pass. Door	-	-

Landing Gear Dimensions:		
	Feet	Inches
AA Nose to Nose Gear Post	25	5
AB Nose Gear Post to Forward Main Gear Post	79	0
AC Nose Gear Post to Rearward Main Gear Post	89	1
AD Maximum Main Gear Width (Outside Tire Edge)	39	9

Door Locations:		
	Feet	Inches
I 1st Passenger Door	31	2
J 2nd Passenger Door	61	8
K 3rd Passenger Door	100	5
L 4th Passenger Door	133	8
M 5th Passenger Door	180	11
N 6th Passenger Door	-	-
O 2nd Level, 1st Pass. Door	50	0
P 2nd Level, 2nd Pass. Door	-	-
Q 2nd Level, 3rd Pass. Door	-	-
R 2nd Level, 4th Pass. Door	-	-

Engine Dimensions:		
	Feet	Inches
S Engine to Centerline (In)	38	4
T Ground Clearance (In)	2	7
U Engine to Centerline (Out)	68	4
V Ground Clearance (Out)	5	1

General Specifications:	
Passenger Capacity	400
Cargo Capacity (Lbs.)	148,412
Fuel Capacity (Gal)	57,065
Empty Weight (Lbs.)	384,088
Max Takeoff Weight (Lbs.)	875,000
Max Landing Weight (Lbs.)	630,000
Runway Length Required (Ft.)	11,000
Service Turn-Around Time (Min.)	60
Approach Speed (Knots)	150
Takeoff Speed (Knots)	-
Pavement Required for 180 Degree Turn (Ft.)	152
Turning Radius of Nose Gear (Ft.)	91
Wingtip Clearance Radii (Ft)	159
Noise Level (Stage Level)	Below 3
Number of Engines	4
Maximum Thrust Per Engine	57,900

BOEING 747-400
AIRPORT DESIGN AIRPLANE AND AIRPORT DATA

Aircraft Approach Category D or E	
Airplane Design Group V	
Airplane wingspan	213.00 feet
Primary runway end approach visibility minimums are lower than CAT I	
Other runway end approach visibility minimums are lower than CAT I	
Airplane undercarriage width (1.15 x main gear track) . . .	40.00 feet
Airport elevation	100 feet
Airplane tail height	63.70 feet

RUNWAY AND TAXIWAY WIDTH AND CLEARANCE STANDARD DIMENSIONS

Airplane Group/ARC

Runway centerline to parallel runway centerline simultaneous operations
when wake turbulence is not treated as a factor:

VFR operations with no intervening taxiway	700 feet
VFR operations with one intervening taxiway	800 feet
VFR operations with two intervening taxiways	1067 feet
IFR approach and departure with approach to near threshold	2500 feet less
100 ft for each 500 ft of threshold stagger to a minimum of 1000 feet.	

Runway centerline to parallel runway centerline simultaneous operations
when wake turbulence is treated as a factor:

VFR operations	2500 feet
IFR departures	2500 feet
IFR approach and departure with approach to near threshold . .	2500 feet
IFR approach and departure with approach to far threshold	2500 feet plus
100 feet for each 500 feet of threshold stagger.	
IFR approaches	3400 feet

Runway centerline to parallel taxiway/taxilane centerline .	393.0	400 feet
Runway centerline to edge of aircraft parking	400.0	500 feet
Runway width		150 feet
Runway shoulder width		35 feet
Runway blast pad width		220 feet
Runway blast pad length		400 feet
Runway safety area width		500 feet
Runway safety area length beyond each runway end or stopway end, whichever is greater		1000 feet
Runway object free area width		800 feet
Runway object free area length beyond each runway end or stopway end, whichever is greater		1000 feet
Clearway width		500 feet
Stopway width		150 feet

Obstacle free zone (OFZ):

Runway OFZ width	400 feet
Runway OFZ length beyond each runway end	200 feet
Inner-approach OFZ width	400 feet
Inner-approach OFZ length beyond approach light system	200 feet
Inner-approach OFZ slope from 200 feet beyond threshold . . .	50:1
Inner-transitional OFZ height H	25.1 25 feet

Inner-transitional OFZ slope out to distance Y	5:1
Inner-transitional OFZ distance Y from runway centerline 668.0	669 feet
Inner-transitional OFZ slope beyond distance Y	6:1

Runway protection zone at the primary runway end:

Width 200 feet from runway end	1000 feet
Width 2700 feet from runway end	1750 feet
Length	2500 feet

Runway protection zone at other runway end:

Width 200 feet from runway end	1000 feet
Width 2700 feet from runway end	1750 feet
Length	2500 feet

Departure runway protection zone:

Width 200 feet from the far end of TORA	500 feet
Width 1900 feet from the far end of TORA	1010 feet
Length	1700 feet

Threshold surface at primary runway end:

Distance out from threshold to start of surface	200 feet
Width of surface at start of trapezoidal section	1000 feet
Width of surface at end of trapezoidal section	4000 feet
Length of trapezoidal section	10000 feet
Length of rectangular section	0 feet
Slope of surface	34:1

Threshold surface at other runway end:

Distance out from threshold to start of surface	200 feet
Width of surface at start of trapezoidal section	1000 feet
Width of surface at end of trapezoidal section	4000 feet
Length of trapezoidal section	10000 feet
Length of rectangular section	0 feet
Slope of surface	34:1

Taxiway centerline to parallel taxiway/taxilane centerline	265.6	267 feet
Taxiway centerline to fixed or movable object	159.1	160 feet
Taxilane centerline to parallel taxilane centerline	244.3	245 feet
Taxilane centerline to fixed or movable object	137.8	138 feet
Taxiway width	70.0	75 feet
Taxiway shoulder width		35 feet
Taxiway safety area width	213.0	214 feet
Taxiway object free area width	318.2	320 feet
Taxilane object free area width	275.6	276 feet
Taxiway edge safety margin		15 feet
Taxiway wingtip clearance	52.6	53 feet
Taxilane wingtip clearance	31.3	31 feet

REFERENCE: AC 150/5300-13, Airport Design, including Changes 1 through 4.

BOEING 747-500X

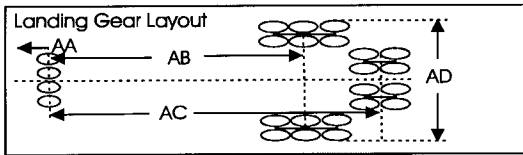
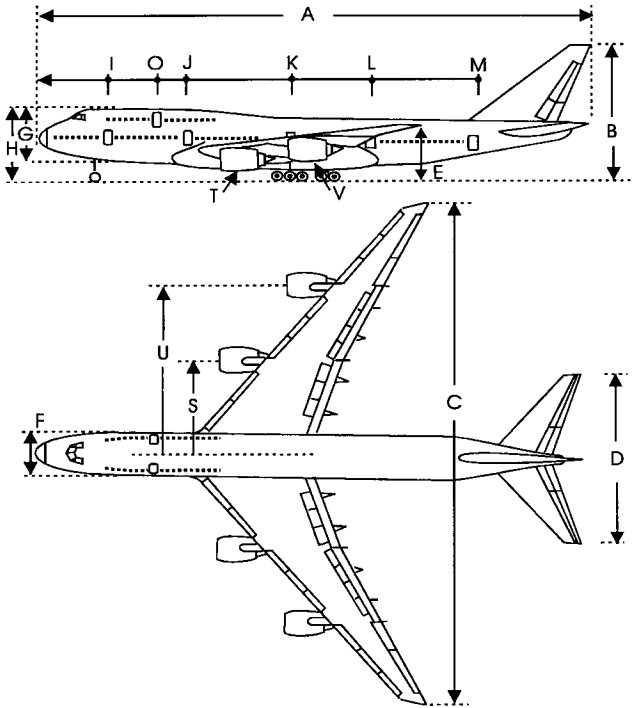

QUICK REFERENCE	
Wingspan:	251' 3"
Length:	250' 5"
Height:	69' 10"
Passenger Capacity:	462
Maximum Takeoff Weight:	1,200,000
Airport Reference Code (ARC):	D-VI

General Dimensions:		Feet	Inches
A	Length (Overall)	250	5
B	Height (Overall)	69	10
C	Wingspan	251	3
D	Tailspan	84	6
E	Wing Tip Ground Clearance	-	-
Fuselage Dimensions:			
F	Fuselage Width	-	-
G	Fuselage Height	-	-
H	Top of Fuselage to Ground	-	-
Door Sill Heights:			
	1st Passenger Door	16	10
	2nd Passenger Door	17	4
	3rd Passenger Door	17	11
	4th Passenger Door	18	5
	5th Passenger Door	19	0
	6th Passenger Door	-	-
	2nd Level, 1st Pass. Door	26	2
	2nd Level, 2nd Pass. Door	-	-
	2nd Level, 3rd Pass. Door	-	-
	2nd Level, 4th Pass. Door	-	-
Landing Gear Dimensions:			
AA	Nose to Nose Gear Post	-	-
AB	Nose Gear Post to Forward Main Gear Post	91	4
AC	Nose Gear Post to Rearward Main Gear Post	107	8
AD	Maximum Main Gear Width (Outside Tire Edge)	40	10
Door Locations:			
I	1st Passenger Door	31	2
J	2nd Passenger Door	68	4
K	3rd Passenger Door	114	11
L	4th Passenger Door	150	2
M	5th Passenger Door	197	5
N	6th Passenger Door	-	-
O	2nd Level, 1st Pass. Door	53	4
P	2nd Level, 2nd Pass. Door	-	-
Q	2nd Level, 3rd Pass. Door	-	-
R	2nd Level, 4th Pass. Door	-	-
Engine Dimensions:			
S	Engine to Centerline (In)	46	0
T	Ground Clearance (In)	4	9
U	Engine to Centerline (Out)	83	6
V	Ground Clearance (Out)	9	8

General Specifications:	
Passenger Capacity	462
Cargo Capacity (Lbs.)	30,400
Fuel Capacity (Gal)	83,500
Empty Weight (Lbs.)	-
Max Takeoff Weight (Lbs.)	1,200,000
Max Landing Weight (Lbs.)	-
Runway Length Required (Ft.)	11,000
Service Turn-Around Time (Min.)	-
Approach Speed (Knots)	-
Takeoff Speed (Knots)	-
Pavement Required for 180 Degree Turn (Ft.)	< 190
Turning Radius of Nose Gear (Ft.)	-
Wingtip Clearance Radii (Ft)	-
Noise Level (Stage Level)	Below 3
Number of Engines	4
Maximum Thrust Per Engine	75,000

BOEING 747-500X
AIRPORT DESIGN AIRPLANE AND AIRPORT DATA

Aircraft Approach Category D or E	
Airplane Design Group VI	
Airplane wingspan	251.00 feet
Primary runway end approach visibility minimums are lower than CAT I	
Other runway end approach visibility minimums are lower than CAT I	
Airplane undercarriage width (1.15 x main gear track) . . .	41.00 feet
Airport elevation	100 feet
Airplane tail height	69.80 feet

RUNWAY AND TAXIWAY WIDTH AND CLEARANCE STANDARD DIMENSIONS

Airplane Group/ARC

Runway centerline to parallel runway centerline simultaneous operations
when wake turbulence is not treated as a factor:

VFR operations with no intervening taxiway	700 feet
VFR operations with one intervening taxiway	1200 feet
VFR operations with two intervening taxiways	1524 feet
IFR approach and departure with approach to near threshold	2500 feet less
100 ft for each 500 ft of threshold stagger to a minimum of 1000 feet.	

Runway centerline to parallel runway centerline simultaneous operations
when wake turbulence is treated as a factor:

VFR operations	2500 feet
IFR departures	2500 feet
IFR approach and departure with approach to near threshold . .	2500 feet
IFR approach and departure with approach to far threshold	2500 feet plus
100 feet for each 500 feet of threshold stagger.	
IFR approaches	3400 feet

Runway centerline to parallel taxiway/taxilane centerline .	448.5	600 feet
Runway centerline to edge of aircraft parking	448.5	500 feet
Runway width		200 feet
Runway shoulder width		40 feet
Runway blast pad width		280 feet
Runway blast pad length		400 feet
Runway safety area width		500 feet
Runway safety area length beyond each runway end		
or stopway end, whichever is greater		1000 feet
Runway object free area width		800 feet
Runway object free area length beyond each runway end		
or stopway end, whichever is greater		1000 feet
Clearway width		500 feet
Stopway width		200 feet

Obstacle free zone (OFZ):

Runway OFZ width	400 feet
Runway OFZ length beyond each runway end	200 feet
Inner-approach OFZ width	400 feet
Inner-approach OFZ length beyond approach light system	200 feet
Inner-approach OFZ slope from 200 feet beyond threshold . . .	50:1
Inner-transitional OFZ height H	20.1 18.7 feet

Inner-transitional OFZ slope out to distance Y	5:1
Inner-transitional OFZ distance Y from runway centerline 709.0	721 feet
Inner-transitional OFZ slope beyond distance Y	6:1

Runway protection zone at the primary runway end:

Width 200 feet from runway end	1000 feet
Width 2700 feet from runway end	1750 feet
Length	2500 feet

Runway protection zone at other runway end:

Width 200 feet from runway end	1000 feet
Width 2700 feet from runway end	1750 feet
Length	2500 feet

Departure runway protection zone:

Width 200 feet from the far end of TORA	500 feet
Width 1900 feet from the far end of TORA	1010 feet
Length	1700 feet

Threshold surface at primary runway end:

Distance out from threshold to start of surface	200 feet
Width of surface at start of trapezoidal section	1000 feet
Width of surface at end of trapezoidal section	4000 feet
Length of trapezoidal section	10000 feet
Length of rectangular section	0 feet
Slope of surface	34:1

Threshold surface at other runway end:

Distance out from threshold to start of surface	200 feet
Width of surface at start of trapezoidal section	1000 feet
Width of surface at end of trapezoidal section	4000 feet
Length of trapezoidal section	10000 feet
Length of rectangular section	0 feet
Slope of surface	34:1

Taxiway centerline to parallel taxiway/taxilane centerline	311.2	324 feet
Taxiway centerline to fixed or movable object	185.7	193 feet
Taxilane centerline to parallel taxilane centerline	286.1	298 feet
Taxilane centerline to fixed or movable object	160.6	167 feet
Taxiway width	81.0	100 feet
Taxiway shoulder width		40 feet
Taxiway safety area width	251.0	262 feet
Taxiway object free area width	371.4	386 feet
Taxilane object free area width	321.2	334 feet
Taxiway edge safety margin		20 feet
Taxiway wingtip clearance	60.2	62 feet
Taxilane wingtip clearance	35.1	36 feet

REFERENCE: AC 150/5300-13, Airport Design, including Changes 1 through 4.

BOEING 747-600X

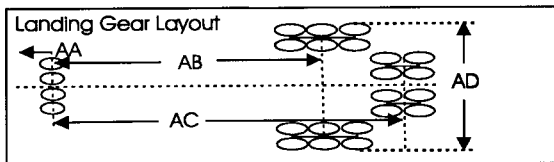
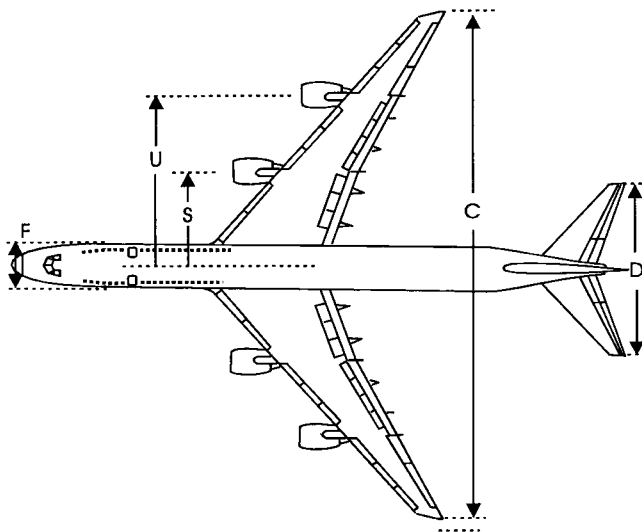
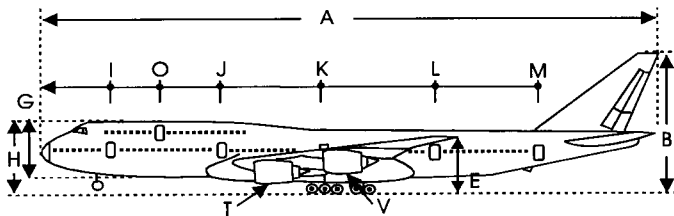

QUICK REFERENCE	
Wingspan:	251' 3"
Length:	278' 9"
Height:	69' 10"
Passenger Capacity:	548
Maximum Takeoff Weight:	1,200,000
Airport Reference Code (ARC):	D-VI

General Dimensions:		Feet	Inches
A	Length (Overall)	278	9
B	Height (Overall)	69	10
C	Wingspan	251	3
D	Tailspan	84	6
E	Wing Tip Ground Clearance	-	-
Fuselage Dimensions:			
F	Fuselage Width	-	-
G	Fuselage Height	-	-
H	Top of Fuselage to Ground	-	-
Door Sill Heights:			
	1st Passenger Door	16	10
	2nd Passenger Door	17	5
	3rd Passenger Door	17	11
	4th Passenger Door	18	6
	5th Passenger Door	19	1
	6th Passenger Door	-	-
	2nd Level, 1st Pass. Door	26	1
	2nd Level, 2nd Pass. Door	-	-
	2nd Level, 3rd Pass. Door	-	-
	2nd Level, 4th Pass. Door	-	-
Landing Gear Dimensions:			
AA	Nose to Nose Gear Post	-	-
AB	Nose Gear Post to Forward Main Gear Post	104	8
AC	Nose Gear Post to Rearward Main Gear Post	121	10
AD	Maximum Main Gear Width (Outside Tire Edge)	40	10
Door Locations:			
I	1st Passenger Door	31	2
J	2nd Passenger Door	81	8
K	3rd Passenger Door	128	3
L	4th Passenger Door	178	6
M	5th Passenger Door	225	9
N	6th Passenger Door	-	-
O	2nd Level, 1st Pass. Door	53	4
P	2nd Level, 2nd Pass. Door	-	-
Q	2nd Level, 3rd Pass. Door	-	-
R	2nd Level, 4th Pass. Door	-	-
Engine Dimensions:			
S	Engine to Centerline (In)	46	0
T	Ground Clearance (In)	4	9
U	Engine to Centerline (Out)	83	6
V	Ground Clearance (Out)	9	8

General Specifications:	
Passenger Capacity	548
Cargo Capacity (Lbs.)	42,800
Fuel Capacity (Gal)	83,500
Empty Weight (Lbs.)	-
Max Takeoff Weight (Lbs.)	1,200,000
Max Landing Weight (Lbs.)	-
Runway Length Required (Ft.)	11,000
Service Turn-Around Time (Min.)	-
Approach Speed (Knots)	-
Takeoff Speed (Knots)	-
Pavement Required for 180 Degree Turn (Ft.)	190
Turning Radius of Nose Gear (Ft.)	-
Wingtip Clearance Radii (Ft)	-
Noise Level (Stage Level)	Below 3
Number of Engines	4
Maximum Thrust Per Engine	75,000

BOEING 747-600X
AIRPORT DESIGN AIRPLANE AND AIRPORT DATA

Aircraft Approach Category D or E	
Airplane Design Group VI	
Airplane wingspan	251.00 feet
Primary runway end approach visibility minimums are lower than CAT I	
Other runway end approach visibility minimums are lower than CAT I	
Airplane undercarriage width (1.15 x main gear track)	41.00 feet
Airport elevation	100 feet
Airplane tail height	69.80 feet

RUNWAY AND TAXIWAY WIDTH AND CLEARANCE STANDARD DIMENSIONS

Airplane Group/ARC

Runway centerline to parallel runway centerline simultaneous operations
when wake turbulence is not treated as a factor:

VFR operations with no intervening taxiway	700 feet
VFR operations with one intervening taxiway	1200 feet
VFR operations with two intervening taxiways	1524 feet
IFR approach and departure with approach to near threshold	2500 feet less
100 ft for each 500 ft of threshold stagger to a minimum of 1000 feet.	

Runway centerline to parallel runway centerline simultaneous operations
when wake turbulence is treated as a factor:

VFR operations	2500 feet
IFR departures	2500 feet
IFR approach and departure with approach to near threshold	2500 feet
IFR approach and departure with approach to far threshold	2500 feet plus
100 feet for each 500 feet of threshold stagger.	
IFR approaches	3400 feet

Runway centerline to parallel taxiway/taxilane centerline	448.5	600 feet
Runway centerline to edge of aircraft parking	448.5	500 feet
Runway width		200 feet
Runway shoulder width		40 feet
Runway blast pad width		280 feet
Runway blast pad length		400 feet
Runway safety area width		500 feet
Runway safety area length beyond each runway end or stopway end, whichever is greater		1000 feet
Runway object free area width		800 feet
Runway object free area length beyond each runway end or stopway end, whichever is greater		1000 feet
Clearway width		500 feet
Stopway width		200 feet

Obstacle free zone (OFZ):

Runway OFZ width	400 feet
Runway OFZ length beyond each runway end	200 feet
Inner-approach OFZ width	400 feet
Inner-approach OFZ length beyond approach light system	200 feet
Inner-approach OFZ slope from 200 feet beyond threshold	50:1
Inner-transitional OFZ height H	20.1 18.7 feet

Inner-transitional OFZ slope out to distance Y	5:1
Inner-transitional OFZ distance Y from runway centerline 709.0	721 feet
Inner-transitional OFZ slope beyond distance Y	6:1

Runway protection zone at the primary runway end:

Width 200 feet from runway end	1000 feet
Width 2700 feet from runway end	1750 feet
Length	2500 feet

Runway protection zone at other runway end:

Width 200 feet from runway end	1000 feet
Width 2700 feet from runway end	1750 feet
Length	2500 feet

Departure runway protection zone:

Width 200 feet from the far end of TORA	500 feet
Width 1900 feet from the far end of TORA	1010 feet
Length	1700 feet

Threshold surface at primary runway end:

Distance out from threshold to start of surface	200 feet
Width of surface at start of trapezoidal section	1000 feet
Width of surface at end of trapezoidal section	4000 feet
Length of trapezoidal section	10000 feet
Length of rectangular section	0 feet
Slope of surface	34:1

Threshold surface at other runway end:

Distance out from threshold to start of surface	200 feet
Width of surface at start of trapezoidal section	1000 feet
Width of surface at end of trapezoidal section	4000 feet
Length of trapezoidal section	10000 feet
Length of rectangular section	0 feet
Slope of surface	34:1

Taxiway centerline to parallel taxiway/taxilane centerline	311.2	324 feet
Taxiway centerline to fixed or movable object	185.7	193 feet
Taxilane centerline to parallel taxilane centerline	286.1	298 feet
Taxilane centerline to fixed or movable object	160.6	167 feet
Taxiway width	81.0	100 feet
Taxiway shoulder width		40 feet
Taxiway safety area width	251.0	262 feet
Taxiway object free area width	371.4	386 feet
Taxilane object free area width	321.2	334 feet
Taxiway edge safety margin		20 feet
Taxiway wingtip clearance	60.2	62 feet
Taxilane wingtip clearance	35.1	36 feet

REFERENCE: AC 150/5300-13, Airport Design, including Changes 1 through 4.

BOEING 777-200

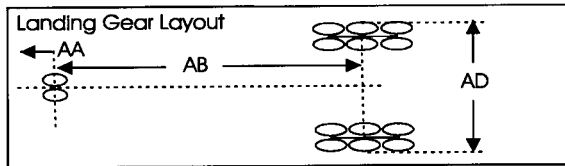
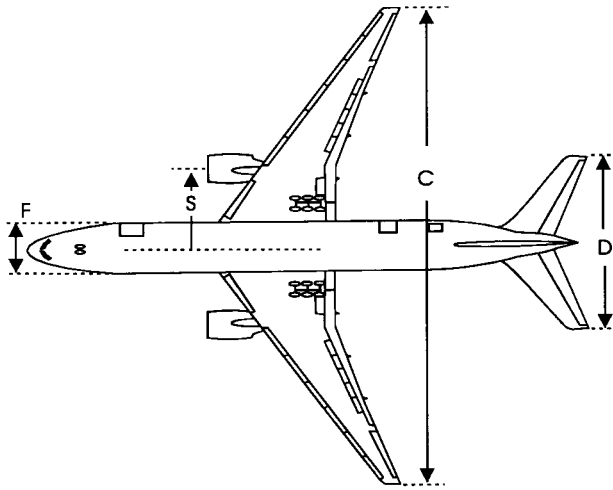
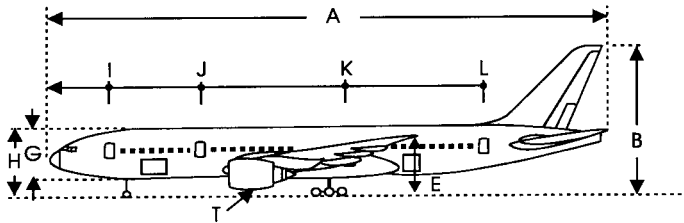

QUICK REFERENCE	
Wingspan:	199' 11"
Length:	206' 6"
Height:	61' 6"
Passenger Capacity:	375
Maximum Takeoff Weight:	535,400
Airport Reference Code (ARC):	D-V

General Dimensions:		Feet	Inches
A	Length (Overall)	206	6
B	Height (Overall)	61	6
C	Wingspan	199	11
D	Tailspan	70	8
E	Wing Tip Ground Clearance	24	0

Fuselage Dimensions:		Feet	Inches
F	Fuselage Width	20	4
G	Fuselage Height	20	0
H	Top of Fuselage to Ground	28	0
Door Sill Heights:			
	1st Passenger Door	16	0
	2nd Passenger Door	16	3
	3rd Passenger Door	17	1
	4th Passenger Door	17	9
	5th Passenger Door	-	-
	6th Passenger Door	-	-
	2nd Level, 1st Pass. Door	-	-
	2nd Level, 2nd Pass. Door	-	-
	2nd Level, 3rd Pass. Door	-	-
	2nd Level, 4th Pass. Door	-	-

Landing Gear Dimensions:		Feet	Inches
AA	Nose to Nose Gear Post	19	4
AB	Nose Gear Post to Forward Main Gear Post	18	11
AC	Nose Gear Post to Rearward Main Gear Post	-	-
AD	Maximum Main Gear Width (Outside Tire Edge)	42	3

Door Locations:		Feet	Inches
I	1st Passenger Door	22	2
J	2nd Passenger Door	56	0
K	3rd Passenger Door	119	2
L	4th Passenger Door	162	6
M	5th Passenger Door	-	-
N	6th Passenger Door	-	-
O	2nd Level, 1st Pass. Door	-	-
P	2nd Level, 2nd Pass. Door	-	-
Q	2nd Level, 3rd Pass. Door	-	-
R	2nd Level, 4th Pass. Door	-	-

Engine Dimensions:		Feet	Inches
S	Engine to Centerline (In)	31	7
T	Ground Clearance (In)	2	10
U	Engine to Centerline (Out)	-	-
V	Ground Clearance (Out)	-	-

General Specifications:	
Passenger Capacity	375
Cargo Capacity (Lbs.)	120,450
Fuel Capacity (Gal)	31,000
Empty Weight (Lbs.)	299,550
Max Takeoff Weight (Lbs.)	535,000
Max Landing Weight (Lbs.)	445,000
Runway Length Required (Ft.)	9,500
Service Turn-Around Time (Min.)	45
Approach Speed (Knots)	-
Takeoff Speed (Knots)	-
Pavement Required for 180 Degree Turn (Ft.)	156
Turning Radius of Nose Gear (Ft.)	95
Wingtip Clearance Radii (Ft)	145
Noise Level (Stage Level)	Below 3
Number of Engines	2
Maximum Thrust Per Engine	76,400

BOEING 777-200
AIRPORT DESIGN AIRPLANE AND AIRPORT DATA

Aircraft Approach Category D or E	
Airplane Design Group V	
Airplane wingspan	200.00 feet
Primary runway end approach visibility minimums are lower than CAT I	
Other runway end approach visibility minimums are lower than CAT I	
Airplane undercarriage width (1.15 x main gear track) . . .	42.00 feet
Airport elevation	100 feet
Airplane tail height	61.50 feet

RUNWAY AND TAXIWAY WIDTH AND CLEARANCE STANDARD DIMENSIONS

Airplane Group/ARC

Runway centerline to parallel runway centerline simultaneous operations
when wake turbulence is not treated as a factor:

VFR operations with no intervening taxiway	700 feet
VFR operations with one intervening taxiway	800 feet
VFR operations with two intervening taxiways	1067 feet
IFR approach and departure with approach to near threshold	2500 feet less
100 ft for each 500 ft of threshold stagger to a minimum of 1000 feet.	

Runway centerline to parallel runway centerline simultaneous operations
when wake turbulence is treated as a factor:

VFR operations	2500 feet
IFR departures	2500 feet
IFR approach and departure with approach to near threshold . .	2500 feet
IFR approach and departure with approach to far threshold	2500 feet plus
100 feet for each 500 feet of threshold stagger.	
IFR approaches	3400 feet

Runway centerline to parallel taxiway/taxilane centerline .	373.5	400 feet
Runway centerline to edge of aircraft parking	400.0	500 feet
Runway width		150 feet
Runway shoulder width		35 feet
Runway blast pad width		220 feet
Runway blast pad length		400 feet
Runway safety area width		500 feet
Runway safety area length beyond each runway end		
or stopway end, whichever is greater		1000 feet
Runway object free area width		800 feet
Runway object free area length beyond each runway end		
or stopway end, whichever is greater		1000 feet
Clearway width		500 feet
Stopway width		150 feet

Obstacle free zone (OFZ):

Runway OFZ width	400 feet
Runway OFZ length beyond each runway end	200 feet
Inner-approach OFZ width	400 feet
Inner-approach OFZ length beyond approach light system	200 feet
Inner-approach OFZ slope from 200 feet beyond threshold . . .	50:1
Inner-transitional OFZ height H	26.8 25 feet

Inner-transitional OFZ slope out to distance Y	5:1
Inner-transitional OFZ distance Y from runway centerline 654.0	669 feet
Inner-transitional OFZ slope beyond distance Y	6:1

Runway protection zone at the primary runway end:

Width 200 feet from runway end	1000 feet
Width 2700 feet from runway end	1750 feet
Length	2500 feet

Runway protection zone at other runway end:

Width 200 feet from runway end	1000 feet
Width 2700 feet from runway end	1750 feet
Length	2500 feet

Departure runway protection zone:

Width 200 feet from the far end of TORA	500 feet
Width 1900 feet from the far end of TORA	1010 feet
Length	1700 feet

Threshold surface at primary runway end:

Distance out from threshold to start of surface	200 feet
Width of surface at start of trapezoidal section	1000 feet
Width of surface at end of trapezoidal section	4000 feet
Length of trapezoidal section	10000 feet
Length of rectangular section	0 feet
Slope of surface	34:1

Threshold surface at other runway end:

Distance out from threshold to start of surface	200 feet
Width of surface at start of trapezoidal section	1000 feet
Width of surface at end of trapezoidal section	4000 feet
Length of trapezoidal section	10000 feet
Length of rectangular section	0 feet
Slope of surface	34:1

Taxiway centerline to parallel taxiway/taxilane centerline	250.0	267 feet
Taxiway centerline to fixed or movable object	150.0	160 feet
Taxilane centerline to parallel taxilane centerline	230.0	245 feet
Taxilane centerline to fixed or movable object	130.0	138 feet
Taxiway width	72.0	75 feet
Taxiway shoulder width		35 feet
Taxiway safety area width	200.0	214 feet
Taxiway object free area width	300.0	320 feet
Taxilane object free area width	260.0	276 feet
Taxiway edge safety margin		15 feet
Taxiway wingtip clearance	50.0	53 feet
Taxilane wingtip clearance	30.0	31 feet

REFERENCE: AC 150/5300-13, Airport Design, including Changes 1 through 4.

BOEING 777-200 B

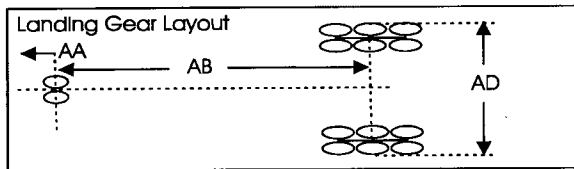
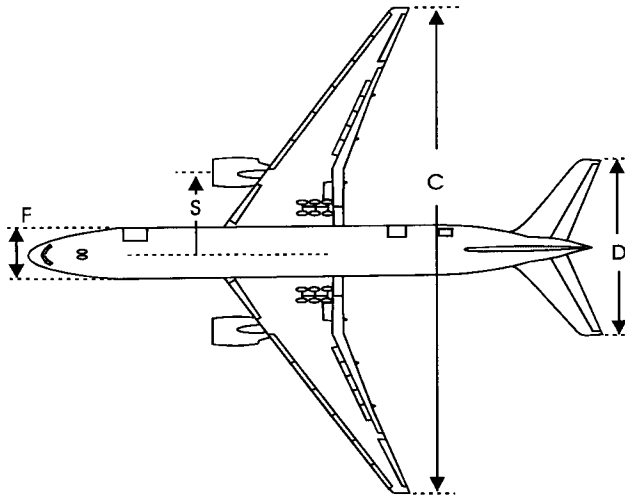
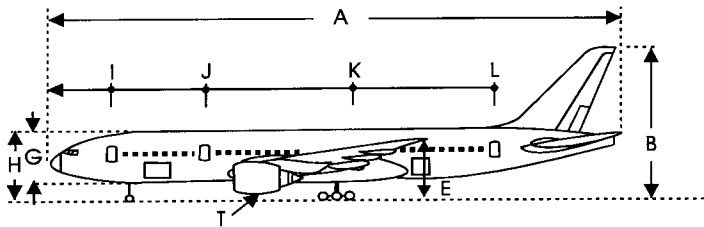

General Specifications:	
Passenger Capacity	375
Cargo Capacity (Lbs.)	120,500
Fuel Capacity (Gal)	44,700
Empty Weight (Lbs.)	304,500
Max Takeoff Weight (Lbs.)	632,500
Max Landing Weight (Lbs.)	455,000
Runway Length Required (Ft.)	10,500
Service Turn-Around Time (Min.)	45
Approach Speed (Knots)	-
Takeoff Speed (Knots)	-
Pavement Required for 180 Degree Turn (Ft.)	156
Turning Radius of Nose Gear (Ft.)	95
Wingtip Clearance Radii (Ft)	145
Noise Level (Stage Level)	Below 3
Number of Engines	2
Maximum Thrust Per Engine	84,700

QUICK REFERENCE	
Wingspan:	199' 11"
Length:	206' 6"
Height:	61' 6"
Passenger Capacity:	375
Maximum Takeoff Weight:	632,500
Airport Reference Code (ARC):	D-V

General Dimensions:		Feet	Inches
A	Length (Overall)	206	6
B	Height (Overall)	61	6
C	Wingspan	199	11
D	Tailspan	70	8
E	Wing Tip Ground Clearance	24	0

Fuselage Dimensions:		Feet	Inches
F	Fuselage Width	20	4
G	Fuselage Height	20	0
H	Top of Fuselage to Ground	28	0
Door Sill Heights:			
	1st Passenger Door	16	0
	2nd Passenger Door	16	3
	3rd Passenger Door	17	1
	4th Passenger Door	17	9
	5th Passenger Door	-	-
	6th Passenger Door	-	-
	2nd Level, 1st Pass. Door	-	-
	2nd Level, 2nd Pass. Door	-	-
	2nd Level, 3rd Pass. Door	-	-
	2nd Level, 4th Pass. Door	-	-

Landing Gear Dimensions:		Feet	Inches
AA	Nose to Nose Gear Post	19	4
AB	Nose Gear Post to Forward Main Gear Post	18	11
AC	Nose Gear Post to Rearward Main Gear Post	-	-
AD	Maximum Main Gear Width (Outside Tire Edge)	42	3

Door Locations:		Feet	Inches
I	1st Passenger Door	22	2
J	2nd Passenger Door	56	0
K	3rd Passenger Door	119	2
L	4th Passenger Door	162	6
M	5th Passenger Door	-	-
N	6th Passenger Door	-	-
O	2nd Level, 1st Pass. Door	-	-
P	2nd Level, 2nd Pass. Door	-	-
Q	2nd Level, 3rd Pass. Door	-	-
R	2nd Level, 4th Pass. Door	-	-

Engine Dimensions:		Feet	Inches
S	Engine to Centerline (In)	31	7
T	Ground Clearance (In)	2	10
U	Engine to Centerline (Out)	-	-
V	Ground Clearance (Out)	-	-

BOEING 777-200B
AIRPORT DESIGN AIRPLANE AND AIRPORT DATA

Aircraft Approach Category D or E	
Airplane Design Group V	
Airplane wingspan	200.00 feet
Primary runway end approach visibility minimums are lower than CAT I	
Other runway end approach visibility minimums are lower than CAT I	
Airplane undercarriage width (1.15 x main gear track) . . .	42.00 feet
Airport elevation	100 feet
Airplane tail height	61.50 feet

RUNWAY AND TAXIWAY WIDTH AND CLEARANCE STANDARD DIMENSIONS

Airplane Group/ARC

Runway centerline to parallel runway centerline simultaneous operations
when wake turbulence is not treated as a factor:

VFR operations with no intervening taxiway	700 feet
VFR operations with one intervening taxiway	800 feet
VFR operations with two intervening taxiways	1067 feet
IFR approach and departure with approach to near threshold	2500 feet less
100 ft for each 500 ft of threshold stagger to a minimum of 1000 feet.	

Runway centerline to parallel runway centerline simultaneous operations
when wake turbulence is treated as a factor:

VFR operations	2500 feet
IFR departures	2500 feet
IFR approach and departure with approach to near threshold . .	2500 feet
IFR approach and departure with approach to far threshold	2500 feet plus
100 feet for each 500 feet of threshold stagger.	
IFR approaches	3400 feet

Runway centerline to parallel taxiway/taxilane centerline . 373.5	400 feet
Runway centerline to edge of aircraft parking 400.0	500 feet
Runway width	150 feet
Runway shoulder width	35 feet
Runway blast pad width	220 feet
Runway blast pad length	400 feet
Runway safety area width	500 feet
Runway safety area length beyond each runway end or stopway end, whichever is greater	1000 feet
Runway object free area width	800 feet
Runway object free area length beyond each runway end or stopway end, whichever is greater	1000 feet
Clearway width	500 feet
Stopway width	150 feet

Obstacle free zone (OFZ):

Runway OFZ width	400 feet
Runway OFZ length beyond each runway end	200 feet
Inner-approach OFZ width	400 feet
Inner-approach OFZ length beyond approach light system	200 feet
Inner-approach OFZ slope from 200 feet beyond threshold . . .	50:1
Inner-transitional OFZ height H 26.8	25 feet

Inner-transitional OFZ slope out to distance Y	5:1
Inner-transitional OFZ distance Y from runway centerline 654.0	669 feet
Inner-transitional OFZ slope beyond distance Y	6:1

Runway protection zone at the primary runway end:

Width 200 feet from runway end	1000 feet
Width 2700 feet from runway end	1750 feet
Length	2500 feet

Runway protection zone at other runway end:

Width 200 feet from runway end	1000 feet
Width 2700 feet from runway end	1750 feet
Length	2500 feet

Departure runway protection zone:

Width 200 feet from the far end of TORA	500 feet
Width 1900 feet from the far end of TORA	1010 feet
Length	1700 feet

Threshold surface at primary runway end:

Distance out from threshold to start of surface	200 feet
Width of surface at start of trapezoidal section	1000 feet
Width of surface at end of trapezoidal section	4000 feet
Length of trapezoidal section	10000 feet
Length of rectangular section	0 feet
Slope of surface	34:1

Threshold surface at other runway end:

Distance out from threshold to start of surface	200 feet
Width of surface at start of trapezoidal section	1000 feet
Width of surface at end of trapezoidal section	4000 feet
Length of trapezoidal section	10000 feet
Length of rectangular section	0 feet
Slope of surface	34:1

Taxiway centerline to parallel taxiway/taxilane centerline 250.0	267 feet
Taxiway centerline to fixed or movable object 150.0	160 feet
Taxilane centerline to parallel taxilane centerline 230.0	245 feet
Taxilane centerline to fixed or movable object 130.0	138 feet
Taxiway width 72.0	75 feet
Taxiway shoulder width	35 feet
Taxiway safety area width 200.0	214 feet
Taxiway object free area width 300.0	320 feet
Taxilane object free area width 260.0	276 feet
Taxiway edge safety margin	15 feet
Taxiway wingtip clearance 50.0	53 feet
Taxilane wingtip clearance 30.0	31 feet

REFERENCE: AC 150/5300-13, Airport Design, including Changes 1 through 4.

BOEING 777-300

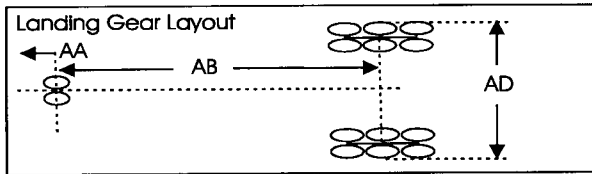
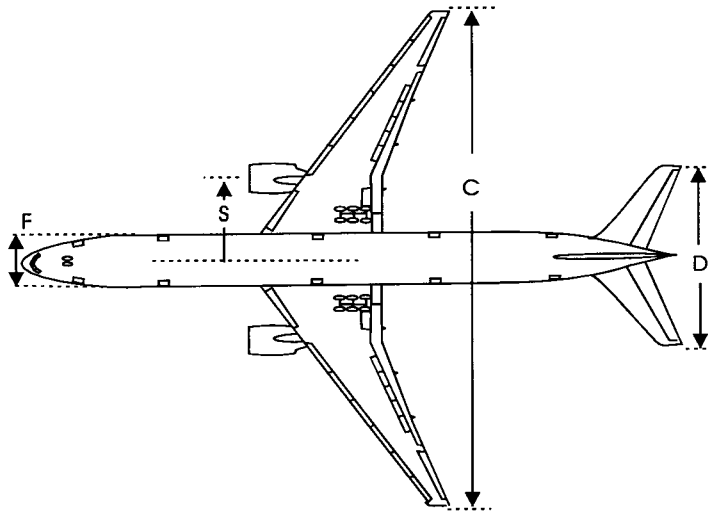
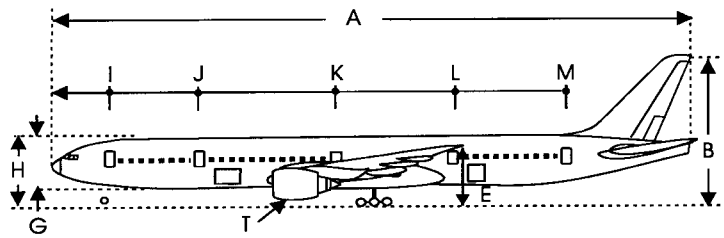

QUICK REFERENCE	
Wingspan:	199' 11"
Length:	242' 4"
Height:	60' 8"
Passenger Capacity:	420
Maximum Takeoff Weight:	660,000
Airport Reference Code (ARC):	D-V

General Dimensions:			
A	Length (Overall)	242	4
B	Height (Overall)	60	8
C	Wingspan	199	11
D	Tailspan	70	8
E	Wing Tip Ground Clearance	24	0
Fuselage Dimensions:			
F	Fuselage Width	20	4
G	Fuselage Height	20	0
H	Top of Fuselage to Ground	28	0
Door Sill Heights:			
	1st Passenger Door	16	0
	2nd Passenger Door	16	3
	3rd Passenger Door	17	1
	4th Passenger Door	17	9
	5th Passenger Door	-	-
	6th Passenger Door	-	-
	2nd Level, 1st Pass. Door	-	-
	2nd Level, 2nd Pass. Door	-	-
	2nd Level, 3rd Pass. Door	-	-
	2nd Level, 4th Pass. Door	-	-
Landing Gear Dimensions:			
AA	Nose to Nose Gear Post	19	4
AB	Nose Gear Post to Forward Main Gear Post	102	5
AC	Nose Gear Post to Rearward Main Gear Post	-	-
AD	Maximum Main Gear Width (Outside Tire Edge)	42	3
Door Locations:			
I	1st Passenger Door	22	2
J	2nd Passenger Door	56	0
K	3rd Passenger Door	108	2
L	4th Passenger Door	152	5
M	5th Passenger Door	195	9
N	6th Passenger Door	-	-
O	2nd Level, 1st Pass. Door	-	-
P	2nd Level, 2nd Pass. Door	-	-
Q	2nd Level, 3rd Pass. Door	-	-
R	2nd Level, 4th Pass. Door	-	-
Engine Dimensions:			
S	Engine to Centerline (In)	31	7
T	Ground Clearance (In)	2	10
U	Engine to Centerline (Out)	-	-
V	Ground Clearance (Out)	-	-

General Specifications:	
Passenger Capacity	420
Cargo Capacity (Lbs.)	-
Fuel Capacity (Gal)	-
Empty Weight (Lbs.)	-
Max Takeoff Weight (Lbs.)	660,000
Max Landing Weight (Lbs.)	-
Runway Length Required (Ft.)	-
Service Turn-Around Time (Min.)	-
Approach Speed (Knots)	-
Takeoff Speed (Knots)	-
Pavement Required for 180 Degree Turn (Ft.)	185
Turning Radius of Nose Gear (Ft.)	-
Wingtip Clearance Radii (Ft)	145
Noise Level (Stage Level)	Below 3
Number of Engines	2
Maximum Thrust Per Engine	98,000

BOEING 777-300
AIRPORT DESIGN AIRPLANE AND AIRPORT DATA

Aircraft Approach Category D or E	
Airplane Design Group V	
Airplane wingspan	200.00 feet
Primary runway end approach visibility minimums are lower than CAT I	
Other runway end approach visibility minimums are lower than CAT I	
Airplane undercarriage width (1.15 x main gear track)	42.00 feet
Airport elevation	100 feet
Airplane tail height	60.70 feet

RUNWAY AND TAXIWAY WIDTH AND CLEARANCE STANDARD DIMENSIONS

Airplane Group/ARC

Runway centerline to parallel runway centerline simultaneous operations
when wake turbulence is not treated as a factor:

VFR operations with no intervening taxiway	700 feet
VFR operations with one intervening taxiway	800 feet
VFR operations with two intervening taxiways	1067 feet
IFR approach and departure with approach to near threshold 100 ft for each 500 ft of threshold stagger to a minimum of 1000 feet.	2500 feet less

Runway centerline to parallel runway centerline simultaneous operations
when wake turbulence is treated as a factor:

VFR operations	2500 feet
IFR departures	2500 feet
IFR approach and departure with approach to near threshold	2500 feet
IFR approach and departure with approach to far threshold 100 feet for each 500 feet of threshold stagger.	2500 feet plus
IFR approaches	3400 feet

Runway centerline to parallel taxiway/taxilane centerline	369.5	400 feet
Runway centerline to edge of aircraft parking	400.0	500 feet
Runway width		150 feet
Runway shoulder width		35 feet
Runway blast pad width		220 feet
Runway blast pad length		400 feet
Runway safety area width		500 feet
Runway safety area length beyond each runway end or stopway end, whichever is greater		1000 feet
Runway object free area width		800 feet
Runway object free area length beyond each runway end or stopway end, whichever is greater		1000 feet
Clearway width		500 feet
Stopway width		150 feet

Obstacle free zone (OFZ):

Runway OFZ width	400 feet
Runway OFZ length beyond each runway end	200 feet
Inner-approach OFZ width	400 feet
Inner-approach OFZ length beyond approach light system	200 feet
Inner-approach OFZ slope from 200 feet beyond threshold	50:1
Inner-transitional OFZ height H	26.8 25 feet

Inner-transitional OFZ slope out to distance Y	5:1
Inner-transitional OFZ distance Y from runway centerline 654.0	669 feet
Inner-transitional OFZ slope beyond distance Y	6:1

Runway protection zone at the primary runway end:

Width 200 feet from runway end	1000 feet
Width 2700 feet from runway end	1750 feet
Length	2500 feet

Runway protection zone at other runway end:

Width 200 feet from runway end	1000 feet
Width 2700 feet from runway end	1750 feet
Length	2500 feet

Departure runway protection zone:

Width 200 feet from the far end of TORA	500 feet
Width 1900 feet from the far end of TORA	1010 feet
Length	1700 feet

Threshold surface at primary runway end:

Distance out from threshold to start of surface	200 feet
Width of surface at start of trapezoidal section	1000 feet
Width of surface at end of trapezoidal section	4000 feet
Length of trapezoidal section	10000 feet
Length of rectangular section	0 feet
Slope of surface	34:1

Threshold surface at other runway end:

Distance out from threshold to start of surface	200 feet
Width of surface at start of trapezoidal section	1000 feet
Width of surface at end of trapezoidal section	4000 feet
Length of trapezoidal section	10000 feet
Length of rectangular section	0 feet
Slope of surface	34:1

Taxiway centerline to parallel taxiway/taxilane centerline	250.0	267 feet
Taxiway centerline to fixed or movable object	150.0	160 feet
Taxilane centerline to parallel taxilane centerline	230.0	245 feet
Taxilane centerline to fixed or movable object	130.0	138 feet
Taxiway width	72.0	75 feet
Taxiway shoulder width		35 feet
Taxiway safety area width	200.0	214 feet
Taxiway object free area width	300.0	320 feet
Taxilane object free area width	260.0	276 feet
Taxiway edge safety margin		15 feet
Taxiway wingtip clearance	50.0	53 feet
Taxilane wingtip clearance	30.0	31 feet

REFERENCE: AC 150/5300-13, Airport Design, including Changes 1 through 4.

BOEING HSCT 10801448

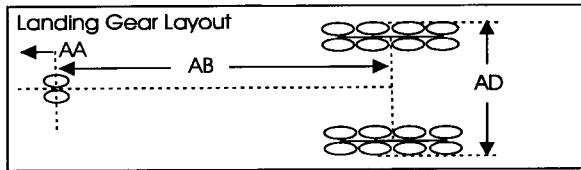
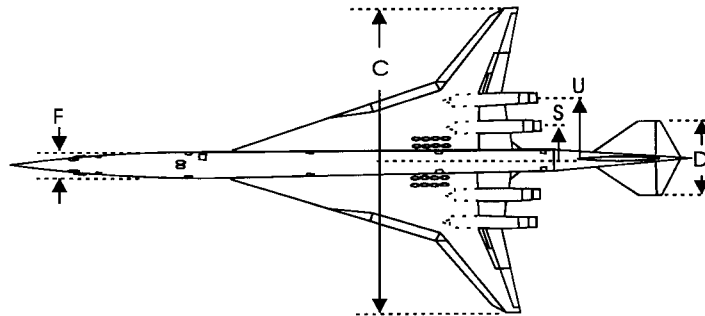
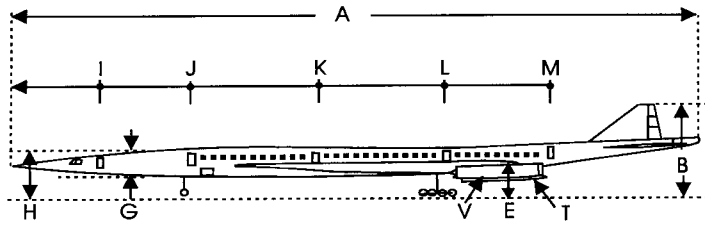

QUICK REFERENCE	
Wingspan:	155' 2"
Length:	326' 0"
Height:	47' 2"
Passenger Capacity:	300
Maximum Takeoff Weight:	644,100
Airport Reference Code (ARC):	D-IV

General Dimensions:		Feet	Inches
A	Length (Overall)	326	0
B	Height (Overall)	47	2
C	Wingspan	155	2
D	Tailspan	32	11
E	Wing Tip Ground Clearance	17	4
Fuselage Dimensions:			
F	Fuselage Width	14	11
G	Fuselage Height	13	11
H	Top of Fuselage to Ground	-	-
Door Sill Heights:			
	1st Passenger Door	12	8
	2nd Passenger Door	15	0
	3rd Passenger Door	16	5
	4th Passenger Door	17	10
	5th Passenger Door	19	8
	6th Passenger Door	-	-
	2nd Level, 1st Pass. Door	-	-
	2nd Level, 2nd Pass. Door	-	-
	2nd Level, 3rd Pass. Door	-	-
	2nd Level, 4th Pass. Door	-	-
Landing Gear Dimensions:			
AA	Nose to Nose Gear Post	81	6
AB	Nose Gear Post to Forward Main Gear Post	118	5
AC	Nose Gear Post to Rearward Main Gear Post	-	-
AD	Maximum Main Gear Width (Outside Tire Edge)	22	4
Door Locations:			
I	1st Passenger Door	42	6
J	2nd Passenger Door	85	2
K	3rd Passenger Door	143	1
L	4th Passenger Door	204	5
M	5th Passenger Door	254	5
N	6th Passenger Door	-	-
O	2nd Level, 1st Pass. Door	-	-
P	2nd Level, 2nd Pass. Door	-	-
Q	2nd Level, 3rd Pass. Door	-	-
R	2nd Level, 4th Pass. Door	-	-
Engine Dimensions:			
S	Engine to Centerline (In)	17	1
T	Ground Clearance (In)	7	8
U	Engine to Centerline (Out)	30	10
V	Ground Clearance (Out)	9	7

General Specifications:	
Passenger Capacity	300
Cargo Capacity (Lbs.)	1,500
Fuel Capacity (Lbs.)	361,651
Empty Weight (Lbs.)	303,500
Max Takeoff Weight (Lbs.)	644,100
Max Landing Weight (Lbs.)	-
Runway Length Required (Ft.)	11,000
Service Turn-Around Time (Min.)	-
Approach Speed (Knots)	155
Takeoff Speed (Knots)	-
Pavement Required for 180 Degree Turn (Ft.)	200
Turning Radius of Nose Gear (Ft.)	-
Wingtip Clearance Radii (Ft)	-
Noise Level (Stage Level)	Below 3
Number of Engines	4
Maximum Thrust Per Engine	50,400

BOEING HSCT
AIRPORT DESIGN AIRPLANE AND AIRPORT DATA

Aircraft Approach Category D or E	
Airplane Design Group IV	
Airplane wingspan	155.20 feet
Primary runway end approach visibility minimums are lower than CAT I	
Other runway end approach visibility minimums are lower than CAT I	
Airplane undercarriage width (1.15 x main gear track) . . .	22.30 feet
Airport elevation	100 feet
Airplane tail height	47.20 feet

RUNWAY AND TAXIWAY WIDTH AND CLEARANCE STANDARD DIMENSIONS

Airplane Group/ARC

Runway centerline to parallel runway centerline simultaneous operations
when wake turbulence is not treated as a factor:

VFR operations with no intervening taxiway	700 feet
VFR operations with one intervening taxiway	800 feet
VFR operations with two intervening taxiways	1015 feet
IFR approach and departure with approach to near threshold	2500 feet less
100 ft for each 500 ft of threshold stagger to a minimum of 1000 feet.	

Runway centerline to parallel runway centerline simultaneous operations
when wake turbulence is treated as a factor:

VFR operations	2500 feet
IFR departures	2500 feet
IFR approach and departure with approach to near threshold . .	2500 feet
IFR approach and departure with approach to far threshold	2500 feet plus
100 feet for each 500 feet of threshold stagger.	
IFR approaches	3400 feet

Runway centerline to parallel taxiway/taxilane centerline . 327.6	400 feet
Runway centerline to edge of aircraft parking 400.0	500 feet
Runway width	150 feet
Runway shoulder width	25 feet
Runway blast pad width	200 feet
Runway blast pad length	200 feet
Runway safety area width	500 feet
Runway safety area length beyond each runway end or stopway end, whichever is greater	1000 feet
Runway object free area width	800 feet
Runway object free area length beyond each runway end or stopway end, whichever is greater	1000 feet
Clearway width	500 feet
Stopway width	150 feet

Obstacle free zone (OFZ):

Runway OFZ width	400 feet
Runway OFZ length beyond each runway end	200 feet
Inner-approach OFZ width	400 feet
Inner-approach OFZ length beyond approach light system	200 feet
Inner-approach OFZ slope from 200 feet beyond threshold . . .	50:1
Inner-transitional OFZ height H 32.6	30.6 feet

Inner-transitional OFZ slope out to distance Y	5:1
Inner-transitional OFZ distance Y from runway centerline 605.0	622 feet
Inner-transitional OFZ slope beyond distance Y	6:1

Runway protection zone at the primary runway end:

Width 200 feet from runway end	1000 feet
Width 2700 feet from runway end	1750 feet
Length	2500 feet

Runway protection zone at other runway end:

Width 200 feet from runway end	1000 feet
Width 2700 feet from runway end	1750 feet
Length	2500 feet

Departure runway protection zone:

Width 200 feet from the far end of TORA	500 feet
Width 1900 feet from the far end of TORA	1010 feet
Length	1700 feet

Threshold surface at primary runway end:

Distance out from threshold to start of surface	200 feet
Width of surface at start of trapezoidal section	1000 feet
Width of surface at end of trapezoidal section	4000 feet
Length of trapezoidal section	10000 feet
Length of rectangular section	0 feet
Slope of surface	34:1

Threshold surface at other runway end:

Distance out from threshold to start of surface	200 feet
Width of surface at start of trapezoidal section	1000 feet
Width of surface at end of trapezoidal section	4000 feet
Length of trapezoidal section	10000 feet
Length of rectangular section	0 feet
Slope of surface	34:1

Taxiway centerline to parallel taxiway/taxilane centerline	196.2	215 feet
Taxiway centerline to fixed or movable object	118.6	129.5 feet
Taxilane centerline to parallel taxilane centerline	180.7	198 feet
Taxilane centerline to fixed or movable object	103.1	112.5 feet
Taxiway width	52.3	75 feet
Taxiway shoulder width		25 feet
Taxiway safety area width	155.2	171 feet
Taxiway object free area width	237.2	259 feet
Taxilane object free area width	206.2	225 feet
Taxiway edge safety margin		15 feet
Taxiway wingtip clearance	41.0	44 feet
Taxilane wingtip clearance	25.5	27 feet

REFERENCE: AC 150/5300-13, Airport Design, including Changes 1 through 4.

McDonnell Douglas MD-XX

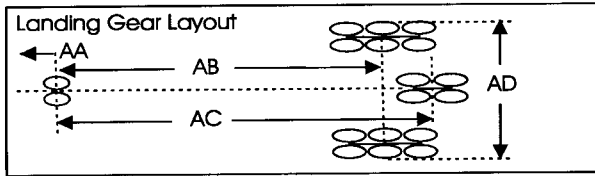
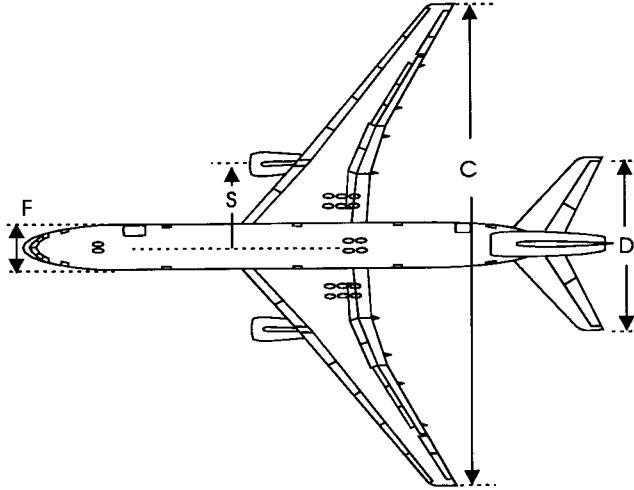
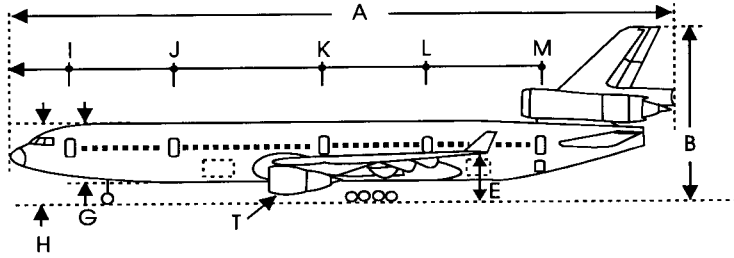

QUICK REFERENCE	
Wingspan:	212' 3"
Length:	234' 4"
Height:	64' 5"
Passenger Capacity:	360
Maximum Takeoff Weight:	802,000
Airport Reference Code (ARC):	D-V

General Dimensions:		Feet	Inches
A	Length (Overall)	234	4
B	Height (Overall)	64	5
C	Wingspan	212	3
D	Tailspan	75	0
E	Wing Tip Ground Clearance	-	-

Fuselage Dimensions:		Feet	Inches
F	Fuselage Width	19	9
G	Fuselage Height	19	9
H	Top of Fuselage to Ground	-	-
Door Sill Heights:			
	1st Passenger Door	17	9
	2nd Passenger Door	17	6
	3rd Passenger Door	17	3
	4th Passenger Door	17	4
	5th Passenger Door	17	7
	6th Passenger Door	-	-
	2nd Level, 1st Pass. Door	-	-
	2nd Level, 2nd Pass. Door	-	-
	2nd Level, 3rd Pass. Door	-	-
	2nd Level, 4th Pass. Door	-	-

Landing Gear Dimensions:		Feet	Inches
AA	Nose to Nose Gear Post	29	6
AB	Nose Gear Post to Forward Main Gear Post	97	3
AC	Nose Gear Post to Rearward Main Gear Post	102	0
AD	Maximum Main Gear Width (Outside Tire Edge)	45	5

Door Locations:		Feet	Inches
I	1st Passenger Door	16	7
J	2nd Passenger Door	57	3
K	3rd Passenger Door	108	9
L	4th Passenger Door	148	9
M	5th Passenger Door	186	3
N	6th Passenger Door	-	-
O	2nd Level, 1st Pass. Door	-	-
P	2nd Level, 2nd Pass. Door	-	-
Q	2nd Level, 3rd Pass. Door	-	-
R	2nd Level, 4th Pass. Door	-	-

Engine Dimensions:		Feet	Inches
S	Engine to Centerline (In)	36	9
T	Ground Clearance (In)	-	-
U	Engine to Centerline (Out)	-	-
V	Ground Clearance (Out)	-	-

General Specifications:	
Passenger Capacity	360
Cargo Capacity (Lbs.)	-
Fuel Capacity (Gal)	54,400
Empty Weight (Lbs.)	381,000
Max Takeoff Weight (Lbs.)	802,000
Max Landing Weight (Lbs.)	568,000
Runway Length Required (Ft.)	9,800
Service Turn-Around Time (Min.)	< 60
Approach Speed (Knots)	148
Takeoff Speed (Knots)	-
Pavement Required for 180 Degree Turn (Ft.)	184
Turning Radius of Nose Gear (Ft.)	116
Wingtip Clearance Radii (Ft)	162
Noise Level (Stage Level)	Below 3
Number of Engines	3
Maximum Thrust Per Engine	65,000 +

MCDONNELL DOUGLAS MD-XX
AIRPORT DESIGN AIRPLANE AND AIRPORT DATA

Aircraft Approach Category D or E	
Airplane Design Group V	
Airplane wingspan	212.20 feet
Primary runway end approach visibility minimums are lower than CAT I	
Other runway end approach visibility minimums are lower than CAT I	
Airplane undercarriage width (1.15 x main gear track)	45.50 feet
Airport elevation	100 feet
Airplane tail height	64.50 feet

RUNWAY AND TAXIWAY WIDTH AND CLEARANCE STANDARD DIMENSIONS

Airplane Group/ARC

Runway centerline to parallel runway centerline simultaneous operations
when wake turbulence is not treated as a factor:

VFR operations with no intervening taxiway	700 feet
VFR operations with one intervening taxiway	800 feet
VFR operations with two intervening taxiways	1067 feet
IFR approach and departure with approach to near threshold	2500 feet less
100 ft for each 500 ft of threshold stagger to a minimum of 1000 feet.	

Runway centerline to parallel runway centerline simultaneous operations
when wake turbulence is treated as a factor:

VFR operations	2500 feet
IFR departures	2500 feet
IFR approach and departure with approach to near threshold	2500 feet
IFR approach and departure with approach to far threshold	2500 feet plus
100 feet for each 500 feet of threshold stagger.	
IFR approaches	3400 feet
Runway centerline to parallel taxiway/taxilane centerline	396.5 400 feet
Runway centerline to edge of aircraft parking	400.0 500 feet
Runway width	150 feet
Runway shoulder width	35 feet
Runway blast pad width	220 feet
Runway blast pad length	400 feet
Runway safety area width	500 feet
Runway safety area length beyond each runway end or stopway end, whichever is greater	1000 feet
Runway object free area width	800 feet
Runway object free area length beyond each runway end or stopway end, whichever is greater	1000 feet
Clearway width	500 feet
Stopway width	150 feet

Obstacle free zone (OFZ):

Runway OFZ width	400 feet
Runway OFZ length beyond each runway end	200 feet
Inner-approach OFZ width	400 feet
Inner-approach OFZ length beyond approach light system	200 feet
Inner-approach OFZ slope from 200 feet beyond threshold	50:1
Inner-transitional OFZ height H	25.2 25 feet

Inner-transitional OFZ slope out to distance Y	5:1
Inner-transitional OFZ distance Y from runway centerline 667.0	669 feet
Inner-transitional OFZ slope beyond distance Y	6:1

Runway protection zone at the primary runway end:

Width 200 feet from runway end	1000 feet
Width 2700 feet from runway end	1750 feet
Length	2500 feet

Runway protection zone at other runway end:

Width 200 feet from runway end	1000 feet
Width 2700 feet from runway end	1750 feet
Length	2500 feet

Departure runway protection zone:

Width 200 feet from the far end of TORA	500 feet
Width 1900 feet from the far end of TORA	1010 feet
Length	1700 feet

Threshold surface at primary runway end:

Distance out from threshold to start of surface	200 feet
Width of surface at start of trapezoidal section	1000 feet
Width of surface at end of trapezoidal section	4000 feet
Length of trapezoidal section	10000 feet
Length of rectangular section	0 feet
Slope of surface	34:1

Threshold surface at other runway end:

Distance out from threshold to start of surface	200 feet
Width of surface at start of trapezoidal section	1000 feet
Width of surface at end of trapezoidal section	4000 feet
Length of trapezoidal section	10000 feet
Length of rectangular section	0 feet
Slope of surface	34:1

Taxiway centerline to parallel taxiway/taxilane centerline	264.6	267 feet
Taxiway centerline to fixed or movable object	158.5	160 feet
Taxilane centerline to parallel taxilane centerline	243.4	245 feet
Taxilane centerline to fixed or movable object	137.3	138 feet
Taxiway width	75.5	75.5 feet
Taxiway shoulder width		35 feet
Taxiway safety area width	212.2	214 feet
Taxiway object free area width	317.0	320 feet
Taxilane object free area width	274.6	276 feet
Taxiway edge safety margin		15 feet
Taxiway wingtip clearance	52.4	53 feet
Taxilane wingtip clearance	31.2	31 feet

REFERENCE: AC 150/5300-13, Airport Design, including Changes 1 through 4.

McDonnell Douglas HSCT

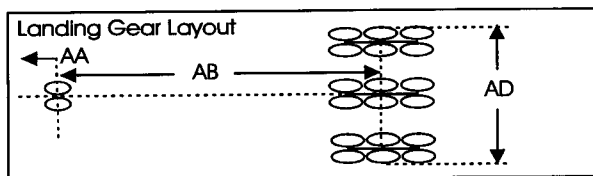
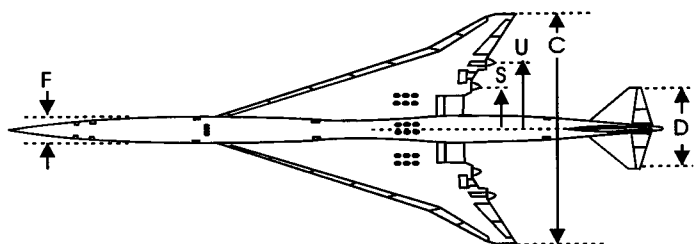
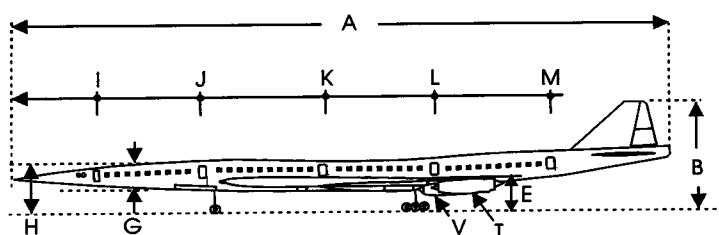

General Specifications:	
Passenger Capacity	300
Cargo Capacity (Lbs.)	-
Fuel Capacity (Gal.)	60,150
Empty Weight (Lbs.)	302,000
Max Takeoff Weight (Lbs.)	753,000
Max Landing Weight (Lbs.)	396,600
Runway Length Required (Ft.)	10,800
Service Turn-Around Time (Min.)	60
Approach Speed (Knots)	157
Takeoff Speed (Knots)	179
Pavement Required for 180 Degree Turn (Ft.)	160
Turning Radius of Nose Gear (Ft.)	109
Wingtip Clearance Radii (Ft)	115
Noise Level (Stage Level)	3
Number of Engines	4
Maximum Thrust Per Engine	59,200

QUICK REFERENCE	
Wingspan:	128' 4"
Length:	334' 0"
Height:	56' 4"
Passenger Capacity:	300
Maximum Takeoff Weight:	753,000
Airport Reference Code (ARC):	D-IV

General Dimensions:		Feet	Inches
A	Length (Overall)	334	0
B	Height (Overall)	56	4
C	Wingspan	128	4
D	Tailspan	45	2
E	Wing Tip Ground Clearance	17	4

Fuselage Dimensions:		Feet	Inches
F	Fuselage Width	16	6
G	Fuselage Height	13	4
H	Top of Fuselage to Ground	31	7
Door Sill Heights:			
	1st Passenger Door	17	6
	2nd Passenger Door	19	5
	3rd Passenger Door	19	2
	4th Passenger Door	19	4
	5th Passenger Door	21	6
	6th Passenger Door	-	-
	2nd Level, 1st Pass. Door	-	-
	2nd Level, 2nd Pass. Door	-	-
	2nd Level, 3rd Pass. Door	-	-
	2nd Level, 4th Pass. Door	-	-

Landing Gear Dimensions:		Feet	Inches
AA	Nose to Nose Gear Post	99	0
AB	Nose Gear Post to Forward Main Gear Post	102	0
AC	Nose Gear Post to Rearward Main Gear Post	-	-
AD	Maximum Main Gear Width (Outside Tire Edge)	33	8

Door Locations:		Feet	Inches
I	1st Passenger Door	42	8
J	2nd Passenger Door	95	0
K	3rd Passenger Door	154	2
L	4th Passenger Door	212	6
M	5th Passenger Door	272	8
N	6th Passenger Door	-	-
O	2nd Level, 1st Pass. Door	-	-
P	2nd Level, 2nd Pass. Door	-	-
Q	2nd Level, 3rd Pass. Door	-	-
R	2nd Level, 4th Pass. Door	-	-

Engine Dimensions:		Feet	Inches
S	Engine to Centerline (In)	24	5
T	Ground Clearance (In)	7	1
U	Engine to Centerline (Out)	37	3
V	Ground Clearance (Out)	9	0

MCDONNELL DOUGLAS HSCT
AIRPORT DESIGN AIRPLANE AND AIRPORT DATA

Aircraft Approach Category D or E	
Airplane Design Group IV	
Airplane wingspan	128.30 feet
Primary runway end approach visibility minimums are lower than CAT I	
Other runway end approach visibility minimums are lower than CAT I	
Airplane undercarriage width (1.15 x main gear track) . . .	33.70 feet
Airport elevation	100 feet
Airplane tail height	56.30 feet

RUNWAY AND TAXIWAY WIDTH AND CLEARANCE STANDARD DIMENSIONS

Airplane Group/ARC

Runway centerline to parallel runway centerline simultaneous operations
when wake turbulence is not treated as a factor:

VFR operations with no intervening taxiway	700 feet
VFR operations with one intervening taxiway	800 feet
VFR operations with two intervening taxiways	1015 feet
IFR approach and departure with approach to near threshold	2500 feet less
100 ft for each 500 ft of threshold stagger to a minimum of 1000 feet.	

Runway centerline to parallel runway centerline simultaneous operations
when wake turbulence is treated as a factor:

VFR operations	2500 feet
IFR departures	2500 feet
IFR approach and departure with approach to near threshold . .	2500 feet
IFR approach and departure with approach to far threshold	2500 feet plus
100 feet for each 500 feet of threshold stagger.	
IFR approaches	3400 feet

Runway centerline to parallel taxiway/taxilane centerline .	314.1	400 feet
Runway centerline to edge of aircraft parking	400.0	500 feet
Runway width		150 feet
Runway shoulder width		25 feet
Runway blast pad width		200 feet
Runway blast pad length		200 feet
Runway safety area width		500 feet
Runway safety area length beyond each runway end		
or stopway end, whichever is greater		1000 feet
Runway object free area width		800 feet
Runway object free area length beyond each runway end		
or stopway end, whichever is greater		1000 feet
Clearway width		500 feet
Stopway width		150 feet

Obstacle free zone (OFZ):

Runway OFZ width	400 feet
Runway OFZ length beyond each runway end	200 feet
Inner-approach OFZ width	400 feet
Inner-approach OFZ length beyond approach light system	200 feet
Inner-approach OFZ slope from 200 feet beyond threshold	50:1
Inner-transitional OFZ height H	36.1 30.6 feet

Inner-transitional OFZ slope out to distance Y	5:1
Inner-transitional OFZ distance Y from runway centerline 576.0	622 feet
Inner-transitional OFZ slope beyond distance Y	6:1

Runway protection zone at the primary runway end:

Width 200 feet from runway end	1000 feet
Width 2700 feet from runway end	1750 feet
Length	2500 feet

Runway protection zone at other runway end:

Width 200 feet from runway end	1000 feet
Width 2700 feet from runway end	1750 feet
Length	2500 feet

Departure runway protection zone:

Width 200 feet from the far end of TORA	500 feet
Width 1900 feet from the far end of TORA	1010 feet
Length	1700 feet

Threshold surface at primary runway end:

Distance out from threshold to start of surface	200 feet
Width of surface at start of trapezoidal section	1000 feet
Width of surface at end of trapezoidal section	4000 feet
Length of trapezoidal section	10000 feet
Length of rectangular section	0 feet
Slope of surface	34:1

Threshold surface at other runway end:

Distance out from threshold to start of surface	200 feet
Width of surface at start of trapezoidal section	1000 feet
Width of surface at end of trapezoidal section	4000 feet
Length of trapezoidal section	10000 feet
Length of rectangular section	0 feet
Slope of surface	34:1

Taxiway centerline to parallel taxiway/taxilane centerline	164.0	215 feet
Taxiway centerline to fixed or movable object	99.8	129.5 feet
Taxilane centerline to parallel taxilane centerline	151.1	198 feet
Taxilane centerline to fixed or movable object	87.0	112.5 feet
Taxiway width	63.8	75 feet
Taxiway shoulder width		25 feet
Taxiway safety area width	128.3	171 feet
Taxiway object free area width	199.7	259 feet
Taxilane object free area width	173.9	225 feet
Taxiway edge safety margin		15 feet
Taxiway wingtip clearance	35.7	44 feet
Taxilane wingtip clearance	22.8	27 feet

REFERENCE: AC 150/5300-13, Airport Design, including Changes 1 through 4.