

DECLASSIFIED

SERVICE

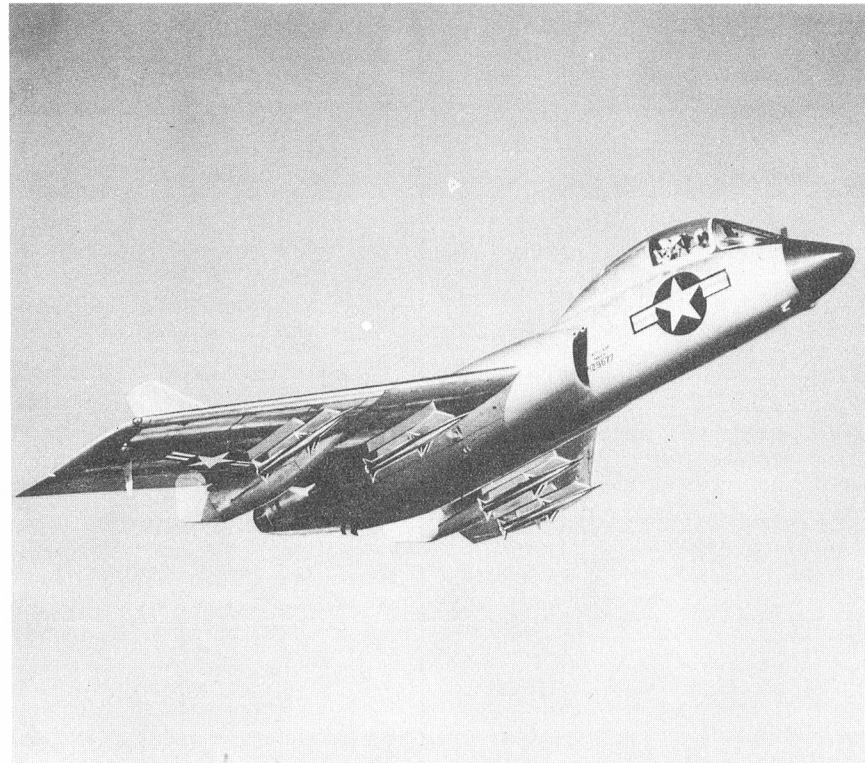

STANDARD AIRCRAFT CHARACTERISTICS

F7U-3M "CUTLASS"

CHANCE VOUGHT

DECLASSIFIED

Standard Aircraft Characteristics NAVAER 1335A (REV. 1-55)

15 MAY 1955

F7U-3M

DESCRIPTIVE ARRANGEMENT

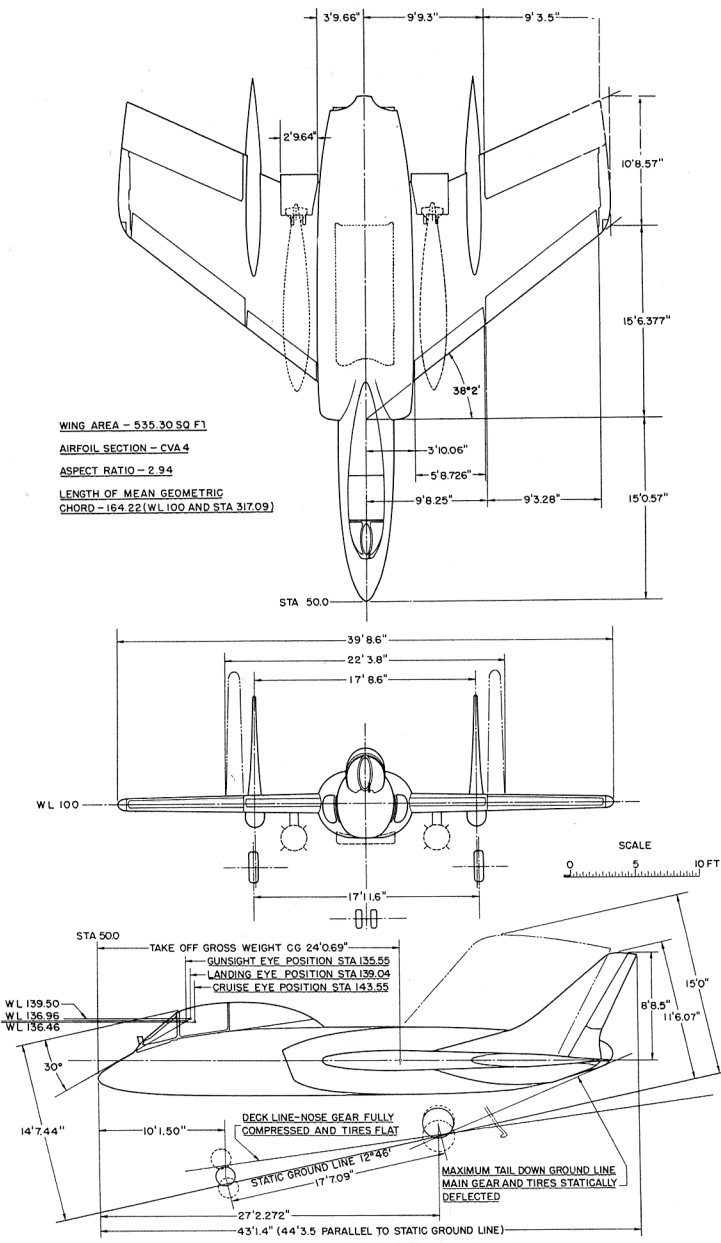

ARMAMENT & TANKS

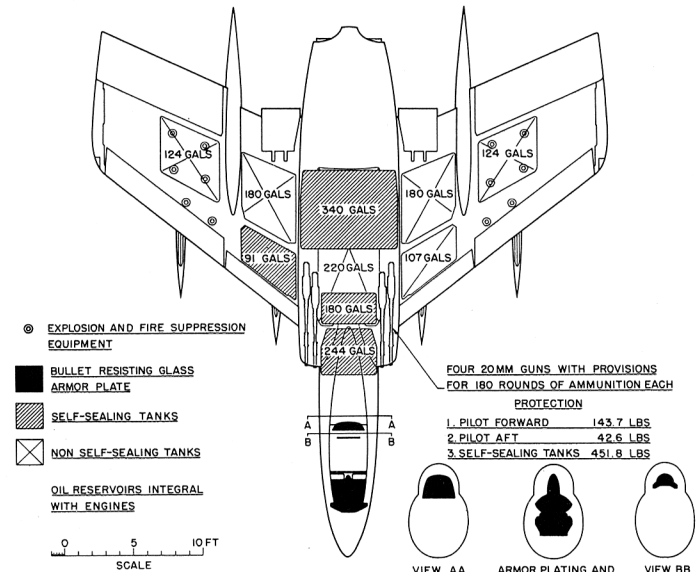

NOTE
 WITHOUT SPARROW I MISSILES, EXT. STORES OF F7U-3M IS EQUIVALENT TO F7U-3 AIRPLANES BUO. 12945-SUBSEQUENT WHICH IS SHOWN IN THE FOLLOWING CHART:

ARRANGEMENT NO.	STORES
1	TWO 1000 LB BOMBS OR TWO 500 LB BOMBS OR TWO 250 LB BOMBS OR LESS
2	TWO 2000 LB BOMBS
3	FUEL POD OR ROCKET STORES
4	TWO 150 GAL DROP TANKS

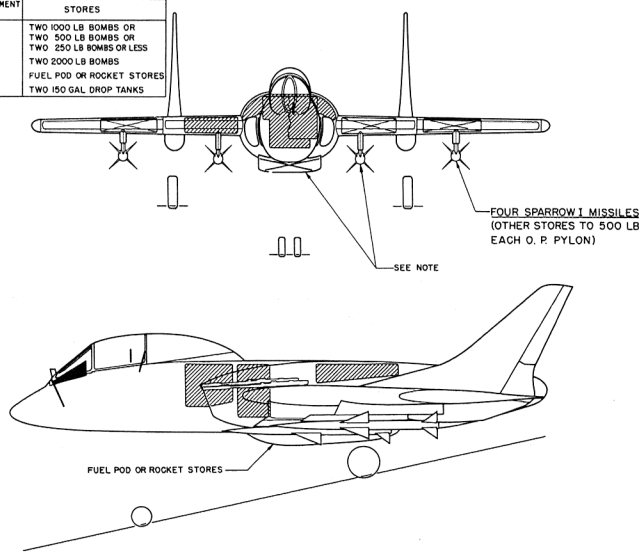

Standard Aircraft Characteristics NAVAER 1335B (Rev. 1-55)

DECLASSIFIED

SERVICE

PERFORMANCE SUMMARY

TAKE-OFF LOADING CONDITION		(1) BASIC FIGHTER	(4) FOUR SPARROW I MISSILES	(7) 220-GAL FUEL POD + FOUR SPARROW I MISSILES
TAKE-OFF WEIGHT	lb.	31,050	32,974	34,704
Fuel	lb.	10,205	10,205	11,635
Payload	lb.	511	1,851	1,851
Wing loading	lb./sq.ft.	58.1	61.7	64.9
Stall speed - power-off	kn.	120	121	124
Take-off run at S.L. - calm	(C) ft.	3,000	3,400	3,700
Take-off run at S.L. 25 kn. wind	(C) ft.	2,050	2,300	2,550
Take-off to clear 50 ft. - calm	(C) ft.	4,100	4,600	5,100
Max. speed/altitude	(A) kn./ft.	469/16,000	398/10,000	387/8,000
Rate of climb at S.L.	(B) fpm.	3,400	2,600	2,350
Time: S.L. to 20,000 ft.	(B) min.	8.0	11.3	13.0
Time: S.L. to 30,000 ft.	(B) min.	17.4	32.4	(E) 38.4
Service ceiling (100 fpm)	(B) ft.	33,600	27,600	25,500
Combat range	n.mi.	760	565	665
Average cruising speed	kn.	450	390	380
Cruising altitude(s)	ft.	28,600-35,000	22,800-29,200	20,500-28,000
Combat radius	n.mi.	230	160	205
Average cruising speed	kn.	450	420	410
Mission time	hrs.	1.43	1.15	1.39

COMBAT LOADING CONDITION		(2) COMBAT	(3) COMBAT	(5) COMBAT (D)	(6) COMBAT (D)	(8) COMBAT (D)	(9) COMBAT (D)
COMBAT WEIGHT	lb.	26,968	26,968	27,552	27,552	28,710	28,710
Engine power		Military	Combat	Military	Combat	Military	Combat
Fuel	lb.	6,123	6,123	6,123	6,123	6,981	6,981
Combat speed/combat altitude	kn./ft.	493/30,000	535/30,000	494/23,750	543/23,750	482/22300	541/22300
Rate of climb/combat altitude	fpm/ft.	880/30,000	4,650/30,000	1,320/23,750	5,620/23,750	1260/22300	5370/22300
Combat ceiling (500 fpm)	ft.	33,400	45,400	31,700	44,400	29,800	42,800
Rate of climb at S.L.	fpm.	4,100	10,500	3,800	9,700	3,450	8,800
Max. speed at S.L.	kn.	501	589	485	579	473	571
Max. speed/altitude	kn./ft.	513/15,000	589/S.L.	501/15,000	579/S.L.	488/15000	571/S.L.
LANDING WEIGHT	lb.	22,755		23,389			23,781
Fuel	lb.	1,910		1,960			2,052
Stall speed - power-off	kn.	110		111			112
Stall speed - with approach power	kn.	105		105			106

NOTES

- (A) Normal Rated Thrust
- (B) Military Rated Thrust
- (C) Combat Rated Thrust
- (D) Sparrows Expended
- (E) Time to climb to 25,500 ft, service ceiling

Performance based on Contractor's flight test

Range and radius are based on engine specification fuel consumption increased by 5%.

30

NAVJER-1335D (Rev. 1-55)

3/

Standard Aircraft Characteristics NAVAR 1335E (Rev. 1-55)

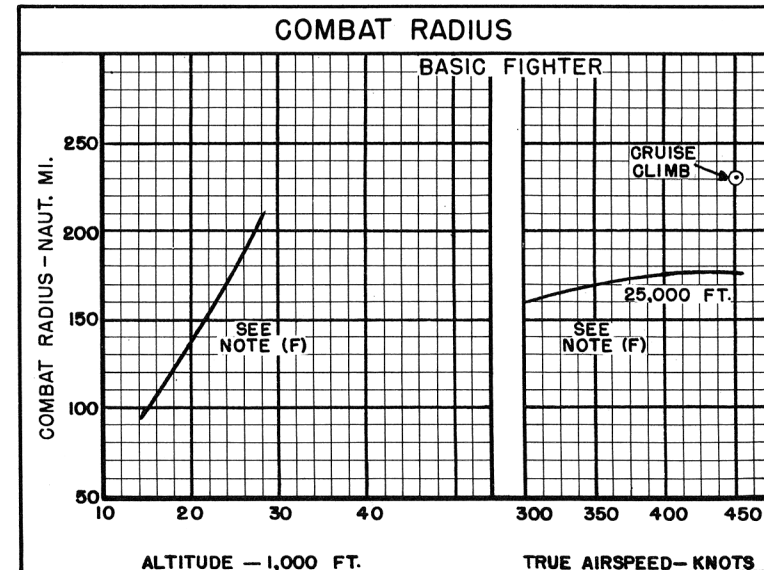
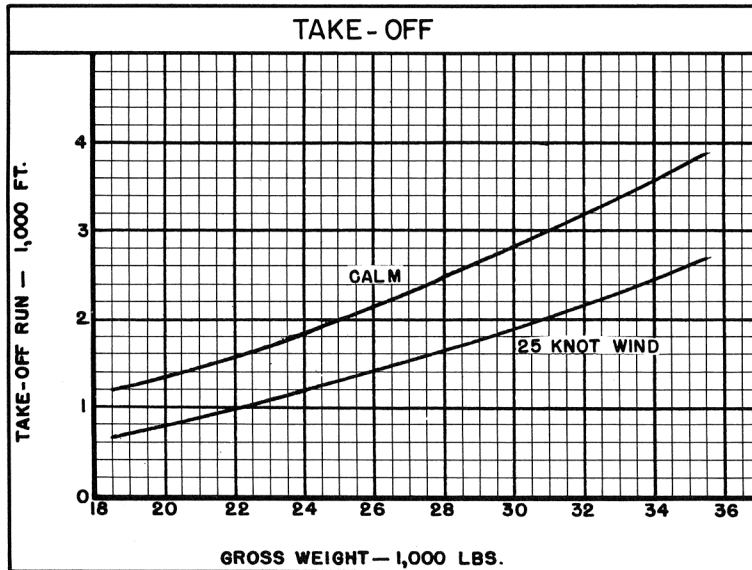
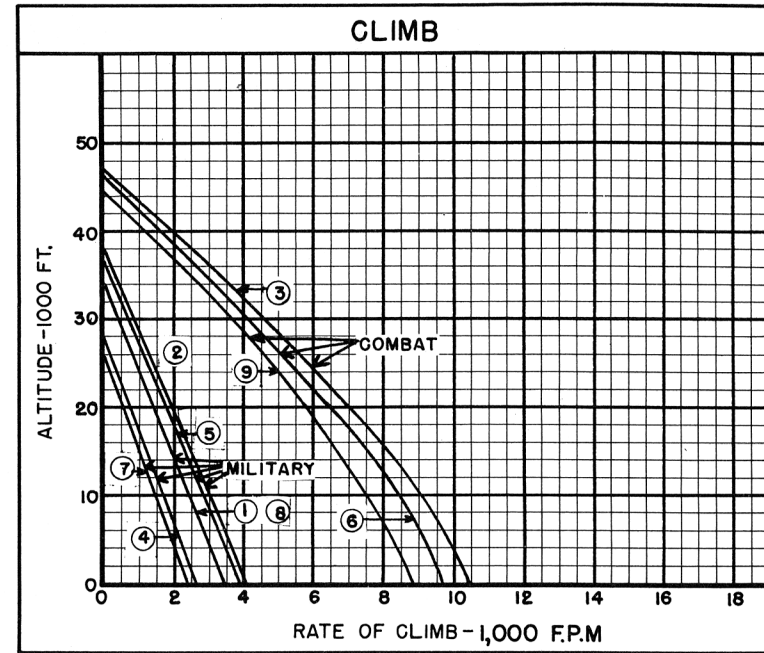
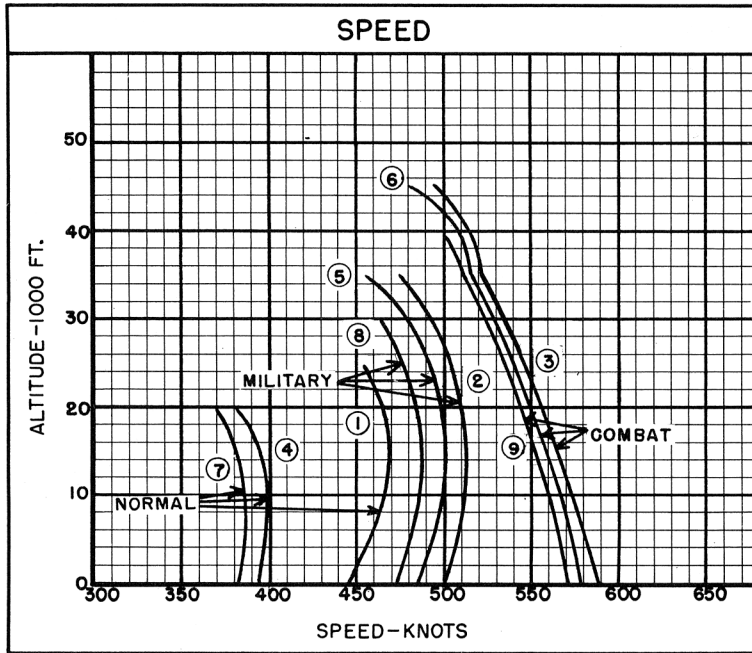

○ LOADING CONDITION COLUMN NUMBER

NOTES

(F) Radius based on cruise at constant specified altitude and combat fuel allowance at 35,000 feet.

GENERAL PURPOSE AND ESCORT FIGHTER COMBAT RADIUS PROBLEM (GAS TURBINE)

WARM-UP, TAXI, TAKE-OFF: 5 minutes at normal thrust plus 1 minute at combat thrust.

CLIMB: To cruising ceiling at military thrust (Cruising ceiling = altitude for 300 ft/min rate of climb at normal thrust)

CRUISE-OUT: At V for long range at cruising ceiling.

COMBAT: At altitude at end of cruise-out for 5 minutes at combat thrust and 15 minutes at military thrust. Finish combat at cruise-back altitude.

CRUISE-BACK: At V for long range at cruising ceiling.

RESERVE: 20 minutes at speed for maximum endurance with both engines operating at sea level plus 5% of initial fuel load.

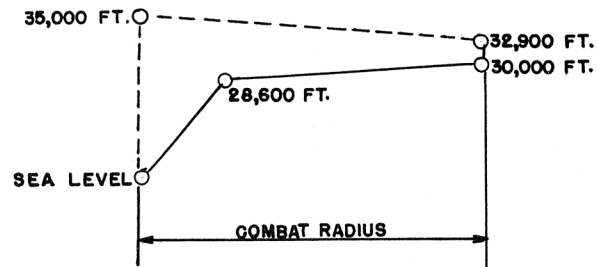

32