



life.augmented

NFC / RFID ST25 product overview





life.augmented

Solutions for NFC / RFID Tags & Readers



ST25 SIMPLY MORE CONNECTED

NFC technology at a glance

An interactive technology enabling engagement with IoT devices



- Near Field Communication, a **short range** wireless technology
 - Operating at **13.56MHz**
 - Based on the RFID HF standard (ISO14443 & ISO15693)
- **Interactive** and **zero power**, enabling convenient connection to the Internet of Things
- ➔ **NFC-enabled mobile phone can engage with items by a simple tap**
- NFC is developed by the NFC Forum
 - **Interoperability** between devices
 - **Standardized** use cases (web link, Bluetooth handover,...)
- Fast growing deployment in Mobile phone
 - In 2022, more than 75% phones to come with NFC
 - NFC is used for Mobile payment (EMVco) like ApplePay
 - Apple added in 2017 support of NFC reader mode from iOS11 onward and support of NFC writer mode from iOS13 in September 2019





NFC in the wireless spectrum

NFC is unique in the wireless spectrum: Short distance, Low data-rate & Zero power consumption for the application

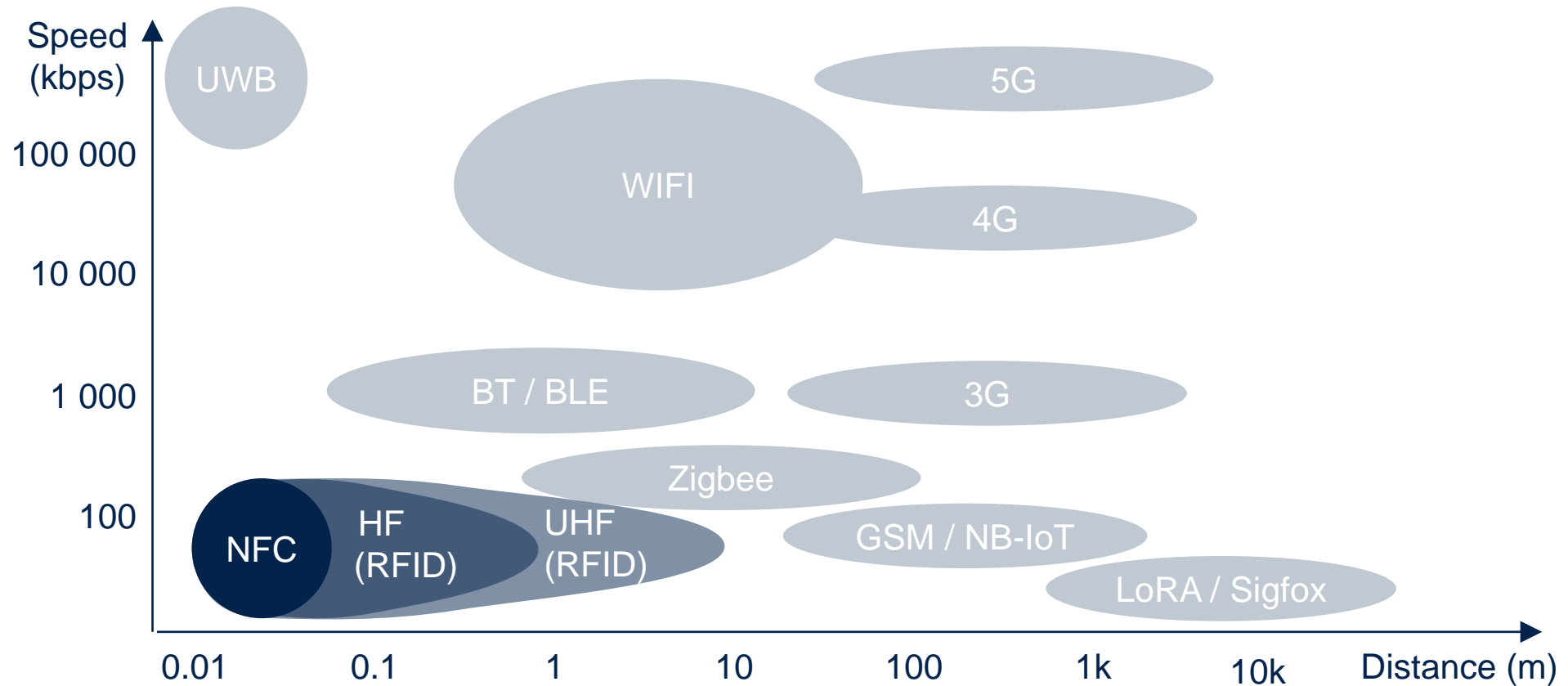

NFC Forum standards

NFC specification
→ Upper layer SW



RFID HF ISO standards
→ HW / SW protocol

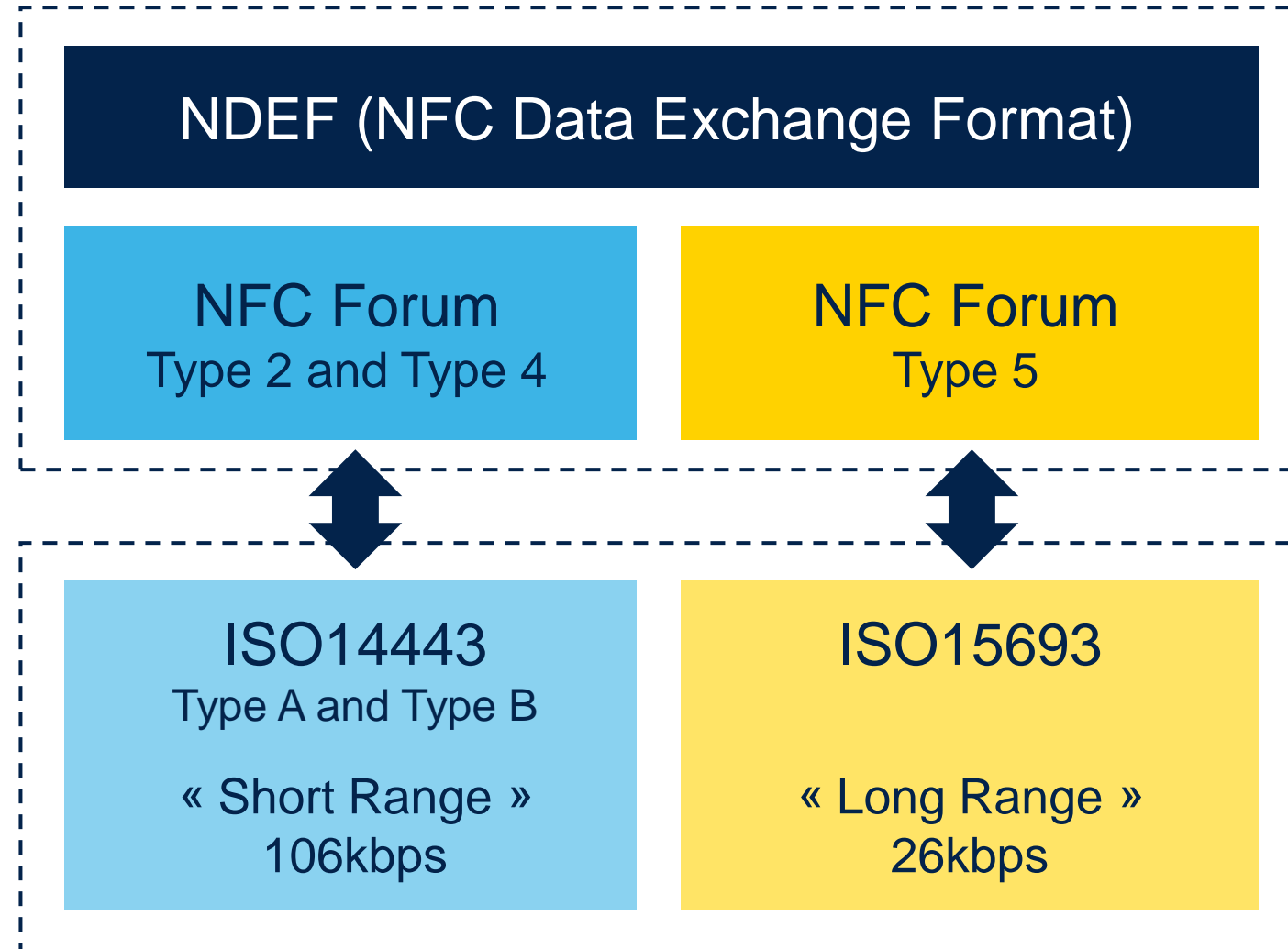

Introduction to the NFC Wayfinding Mark

- N-Mark is (still) the official logo of NFC Forum and used for certified products.



- Wayfinding Mark is made for ensure optimal NFC User eXperience.



Directional

- Occasional use
- Tapping point



Charging

- Charging use
- Antenna location



Simplified

- Everyday use
- For NFC familiar users



Instructional

- Learning / one time use
- For guidance of tapping



- More details on the webpage: <https://nfc-forum.org/wayfinding-mark/>
- Instructions on how to use the wayfinding mark is are in the guidelines: <https://nfc-forum.org/wp-content/uploads/2021/11/Wayfinding-Mark-Guidelines.pdf>

Typical NFC / RFID range

NFC Phones



Up to 5cm (2in.)



Up to 7cm (3in.)

RFID Readers



Up to 10cm (4in.)



Up to 1m (3ft)

- ISO14443 (NFC Forum Type 2 & Type 4) is called « **short range** » standard while with higher RF speed
- ISO15693 (NFC Forum Type 5) is called « **long range** » standard

From factory to consumer bridging RFID and NFC



ISO
15693

1 meter
few feet



NFC
Type 5



ST25 matching ST strategy

Making **driving** safer, greener and more connected



Car Digital Key
Car access & car center console



Enabling the evolution of **industry** towards smarter, safer and more efficient factories and workplaces

Lighting & Metering
Asset tracking
Factory automation



Making **homes & cities** smarter, for better living, higher security, and to get more from available resources



Smart cities
Home appliance & automation



Making everyday **things** smarter, connected and more aware of their surroundings

Wearable & Healthcare
Gaming
Payment

ST NFC portfolio

Covering all NFC application needs and leveraging a rich ecosystem

 www.st.com/nfc

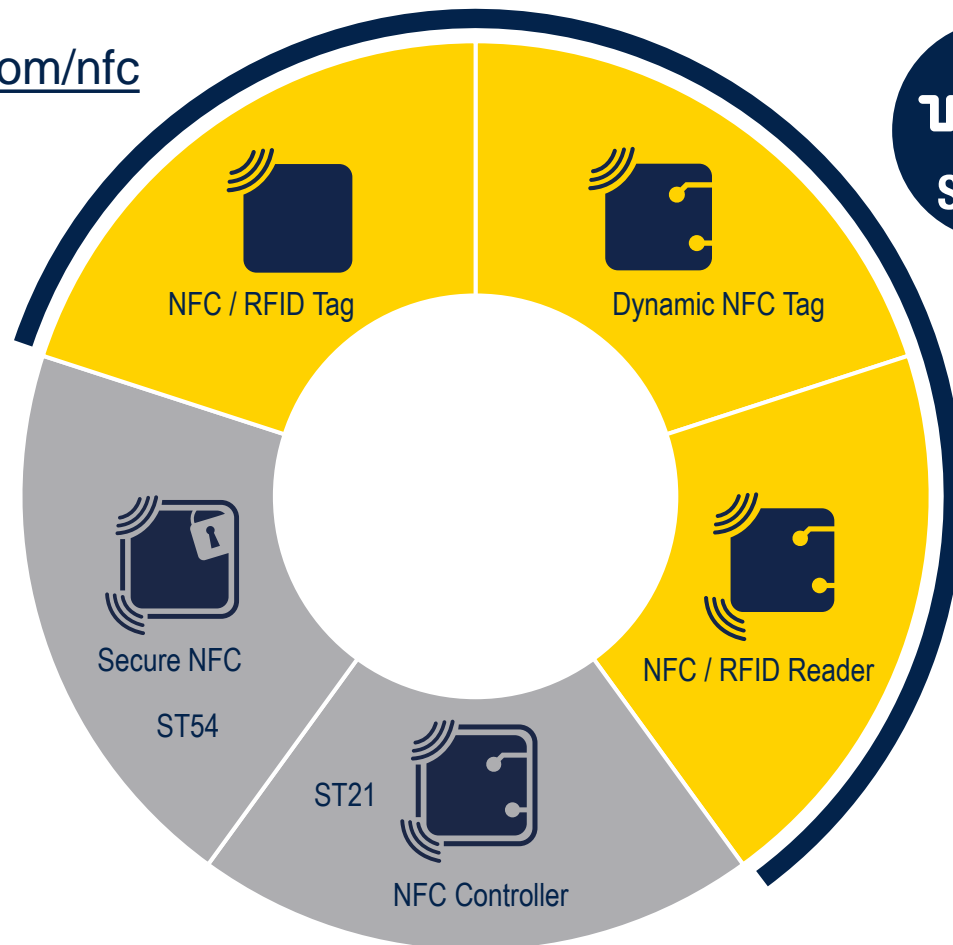

STMicroelectronics is Member of

- NFC Forum
- RAIN alliance
- ISO organizations
- Zhaga consortium
- CCC (Car Connectivity Consortium)
- WPC (Wireless Power Consortium)
- CSA (Connectivity Standards Alliance)
- LoRa alliance

ST25 products family

Consumer engagement, Asset tracking, Ticketing, Brand protection, Access control, Gaming...

www.st.com/st25t



NFC phone / RFID Reader

Industrial, Lighting, Metering, Motor control, Consumer, Appliance, Healthcare...

www.st.com/st25d



NFC phone / RFID Reader

POS & mPOS terminals, Automotive, Access control, Gaming, Reader+Tag...

www.st.com/st25r

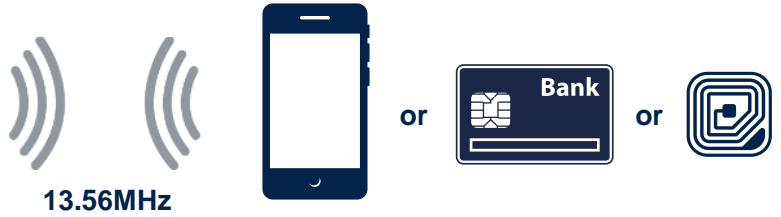

NFC phone

ST25 series enriching our lives!



Consumer
Home Appliance



Healthcare
Gaming



Brand recognition
Accessory

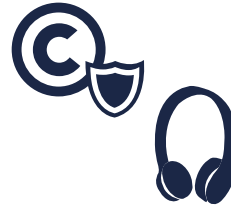

Asset
Tracking



Transport



Main Applications



Industrial



Smart Home
Smart City



Access
control



Automotive



Point
of sales



Certification & interoperability status



Tags

Dynamic Tags

Readers

ST25TV

ST25TA

ST25DV-I2C

ST25DV-PWM

ST25R3911B

ST25R3916B

NFC Forum



NFC Forum



iOS app



RFAL SW



Android app



Linux SW



ST25 series overview





ST25 tags & dynamic tags DNA

Comprehensive portfolio

Standard Compliant



NFC Forum

ISO14443A

ISO14443B

ISO15693

Feature- rich

13.56MHz

I2C interface

Energy Harvesting

Fast Transfer Mode

Digital Signature TruST25

Counter / Unique Tap Code

Best-In-Class Memory

From 512-bit to 64-Kbit

1M erase-write cycles

Up to 200 years retention

128-bit password

OTP bits

High Volume & Quality

In-House manufacturing

Leverage Automotive EEPROM quality

Leverage Consumer EEPROM volume



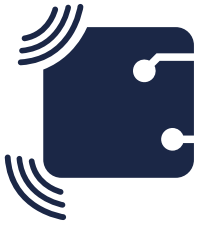

ST25 readers DNA

Comprehensive portfolio

Standard Compliant



NFC Forum



ISO14443A/B

ISO15693

ISO18092

ISO18000



High performing HF readers

13.56MHz

Very High Bit Rate (6.8Mbit/s)

Automatic Antenna Tuning

High output power (1.6W)

Low power wake-up modes

Temperature -40°C to 105°C

High performing UHF readers

840-960MHz

High Rx Sensitivity (-90dBm)

Low noise Voltage Controlled Oscillator

Dense Reader Mode filters

Tag movement detection

Certification

EMVCo

PBOC

Automotive AEC-Q100

FCC

CE mark



Antenna e-design and matching tools

Fast and easy prototyping

Antenna eDesign suite

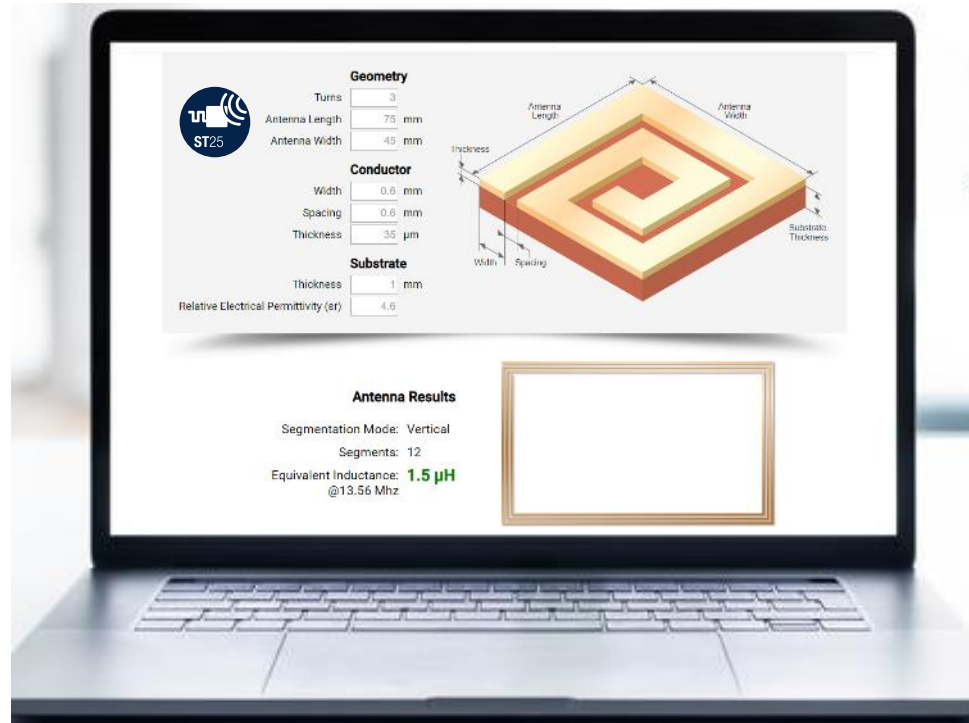

ST25R antenna matching tool

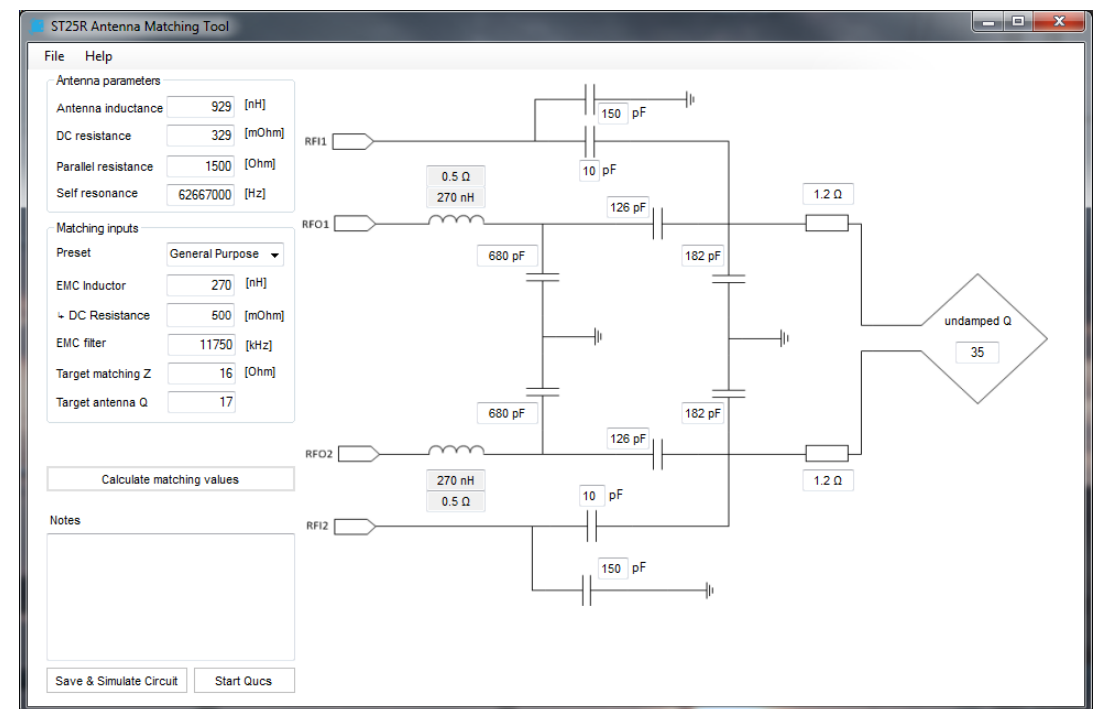

ST25 eco-system DNA

Easy-to-use and customer-oriented



STM32Nucleo
HW ecosystem



Discovery kit
STM32 based



Antenna
e-design tool



Schematic,
BOM, Gerber

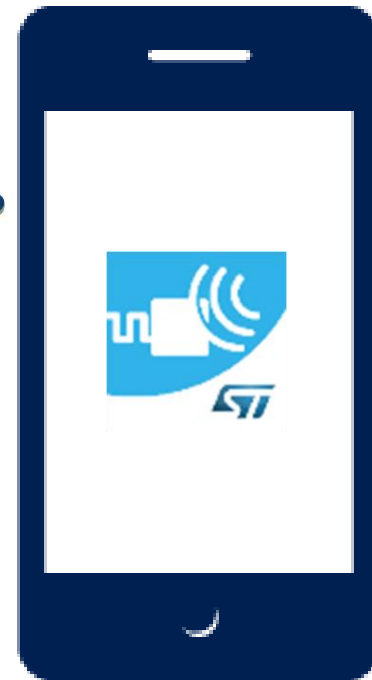
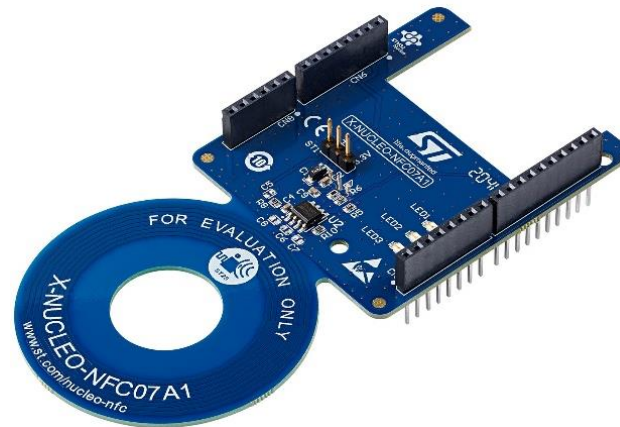

Mobile apps
ST25 SDK



STM32Cube
SW ecosystem



PC software tool
ST25 SDK



Documentation

ST25 products family

Consumer engagement, Asset tracking, Ticketing, Brand protection, Access control, Gaming...

www.st.com/st25t



NFC phone / RFID Reader

Industrial, Lighting, Metering, Motor control, Consumer, Appliance, Healthcare...

www.st.com/st25d



NFC phone / RFID Reader

POS & mPOS terminals, Automotive, Access control, Gaming, Reader+Tag...

www.st.com/st25r

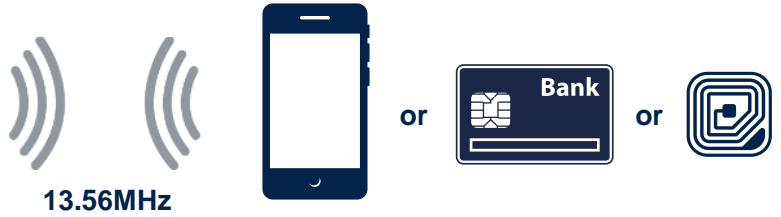

NFC phone

ST25 NFC / RFID portfolio

one-stop-shop for tags and readers

Tags				Dynamic Tags			NFC / HF Readers					UHF Readers
ST25TA	ST25TB	ST25TN	ST25TV	M24SR	ST25DV-I2C EVO *	ST25DV-PWM	ST25R95 ²	ST25R3911B ST25R3912	ST25R3914 ST25R3915	ST25R3916B ST25R3917B ST25R3918	ST25R3920B	ST25RU3993
ISO14443-A 106kbps NFC Type 4	ISO14443-B 106Kbps	ISO14443-A 106kbps NFC Type 2	ISO15693 up to 53Kbps NFC Type 5	ISO14443-A 106kbps NFC Type 4	ISO15693 up to 53kbps NFC Type 5	ISO15693 up to 53kbps NFC Type 5	ISO14443-A/B ISO15693	ISO14443-A/B Felica ISO15693 ISO18092	ISO14443-A/B Felica ISO15693 ISO18092	ISO14443-A/B Felica ISO15693 ISO18092	ISO14443-A/B Felica ISO15693 ISO18092	ISO18000 6c & b Gen2 Protocol
EEPROM 512b-64Kb 200-year retention 1M cycles	EEPROM 512b-04Kb 40-year retention 1M cycles	EEPROM 512b-1.6Kb 40-year retention 100k cycles	EEPROM 512b-64Kb 60-year retention 100k cycles	EEPROM 2Kb-64Kb 200-year retention 1M cycles	256B Buffer EEPROM 4Kb-64Kb 40-year retention 1M cycles	EEPROM 2Kb 40-year retention 100k cycles	Reader/Writer Card Emulation	Reader/Writer P2P EMVco & PBOC	Reader/Writer P2P AEC-Q100	Reader/Writer P2P Card Emulation EMVco & PBOC	Reader/Writer P2P Card Emulation AEC-Q100	Reader / Writer -90dBm sensitivity Internal VCO
TruST25 digital signature 128b password 20b counter UID RF Field Detect	32b counter Lock OTP bits UID	Augmented NDEF TruST25 digital signature 24b UTC UID	Augmented NDEF TruST25 digital signature 64b password 24b UTC UID Tamper Detect	128b password RF disable RF Detect UID	Fast X-fer Mode 64b password E-Harvesting RF Detect UID	TruST25 digital signature 64b password UID		VHBR Auto Antenna Tuning Dynamic Power Out Multi-antenna	Auto Antenna Tuning Dynamic Power Out Multi-antenna	Active wave shaping v2 Auto Antenna Tuning Dynamic Power Out Multi-antenna	Active wave shaping Auto Antenna Tuning Dynamic Power Out Multi-antenna	Dense Reader Mode Linear RSSI Automatic PSRR Auto ACK
				I2C 1MHz 2.4V-5.5V	I2C 1MHz Write 16B page 1.8V-5.5V	2x PWM 488-31.25 kHz 1.8V-5.5V	SPI 2Mbps UART 2.7V-5.5V 0.23W	SPI 6Mbps 2.4V-5.5V 1.4W – 1W	SPI 6Mbps 2.4V-5.5V 1W	SPI 10Mbps I2C 3.4Mbps 2.4V-5.5V 1.6W – 0.5W	SPI 5Mbps I2C 3.4Mbps 2.4V-5.5V 1.6W	SPI 10Mbps 1.65V-5.5V 0-20dBm
SBN12 / SBN075 / FPN5	SBN12	SBN12 / SBN075 / FPN5	SBN12 / SBN075 / FPN5	SO8 / TSSOP8 / FPN8 / SBN12	SO8 / TSSOP8 / FPN8 / FPN12 / WLCSP10	SO8 / TSSOP8	32-pin QFN	WF 32-pin QFN / 32-pin QFN / WLCSP-30 / Wafer	WF 32-pin QFN / 32-pin QFN	WF 32-pin QFN / WLCSP-36	WF 32-pin QFN	48-pin QFN

*: successor of M24LR
and ST25DV-I2C

²: same as former CR95HF / ST95HF



ST25T product ID cards





ST25TN

Entry level NFC type 2 tag



ST25TN512 / 01K

RF Tag	ISO/IEC 14443-A	EEPROM Up to 1664-bit
	NFC Type 2	Augmented NDEF
	106kb/s	TruST25 Digital signature



UFDPN5



SBN12 / SBN075

Die form, sawn and Bumped inkless 8" wafer, 120µm/75µm thickness

Use cases

- Product configuration, accessory recognition, smart poster, gaming
- NFC consumer engagement, NFC token



Key Features

- **ISO/IEC 14443-A and NFC Type 2 Tag**
- High speed operations (**106kb/s**)
- **Memory configuration** : 512-bit and 1280-bit (up to 1664-bit depending on features usage)
- 24-bit **Unique Tap Code (UTC)** with anti-tearing
- **Customizable Augmented NDEF** with UID and UTC
- **TruST25** digital signature

Key Benefits

- Tiny DFN5 package (1.7x1.4mm)
- 50pF internal RF tuning capacitor allowing small antenna design
- **40 years** data retention, 100K cycles erase/write
- Cost effective applications





NFC type 5 tag with Augmented NDEF



ST25TV512C / 02KC

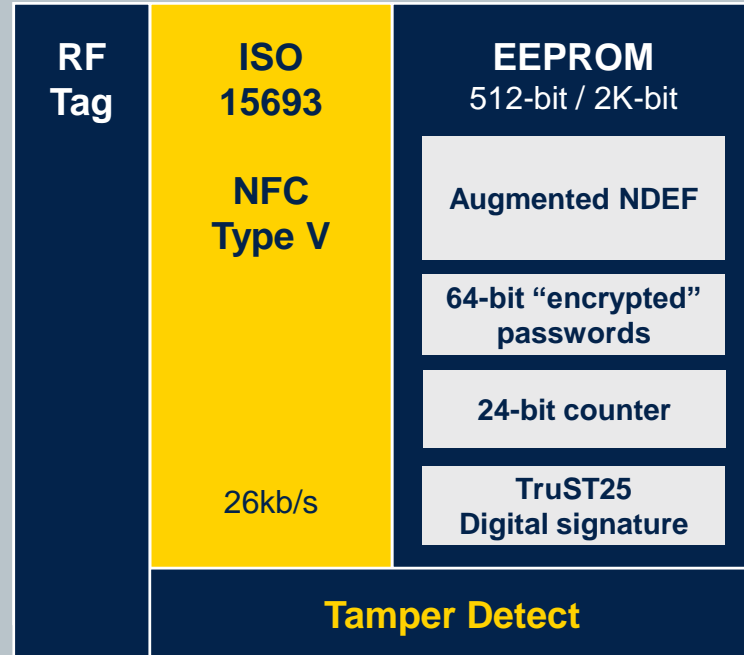

FPN5



SBN12 / SBN075

Die form, sawn and Bumped inkless 8" wafer, 120µm/75µm thickness

Use cases

- Product Identification, asset tracking, consumer engagement, access control, gaming
- Tamper proof application, brand protection



Key Features

- ISO15693 and **NFC Type V** (long range operations, 26kb/s)
- Memory configuration : 512-bit and up to 2560-bit
- **TruST25 Digital Signature** (can be used into ANDEF : 2K-bit only)
- 24-bit **Unique Tap Code (UTC)** with anti-tearing
- Untraceable (by default possible) & Kill modes
- Tamper Detect pin for open / short detection
- **Augmented NDEF**: UID, UTC, tamper status, signature, password counter...

Key Benefits

- Configurable User Memory Area
- Cloning Protection with Digital Signature (Cloud management)
- **60 years** data retention, **100k cycles** erase/write



ST25TV04K-PE Energy harvesting NFC type 5 tag



ST25TV04K-PE

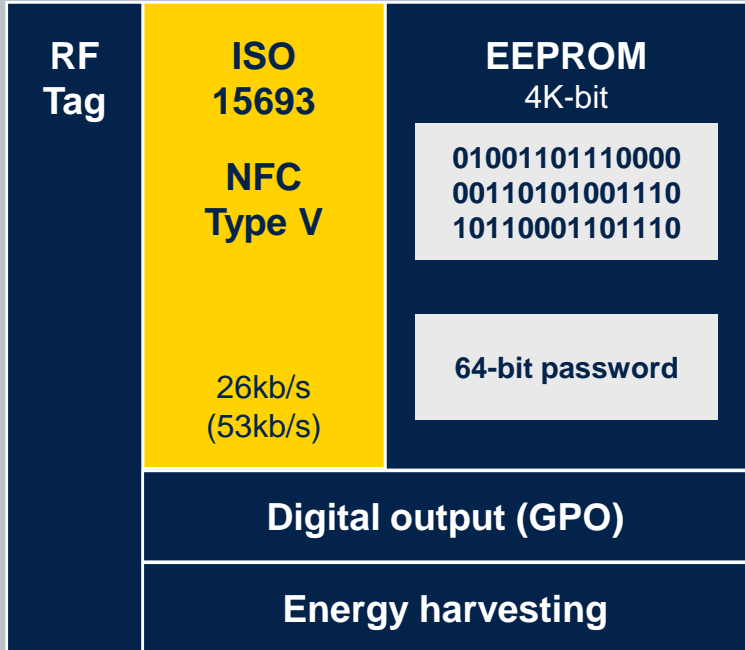

SBN12

Die form, sawn and Bumped inkless 8" wafer, 120µm thickness

Use cases

- Asset tracking, Product identification
- Inventory management
- Gaming

Key Features

- **ISO15693** and **NFC Type V**
- **Long range** operations, up to 53kb/s speed
- **Energy Harvesting** function through RF
- **Configurable output GPO** pin providing RF activity information

Key Benefits

- Temperature range -40°C to +85°C
- Enhanced protection with multiple **64-bit password**
- **40 years** data retention, **1M cycles** erase/write



ST25TV

High density NFC type 5 tag



ST25TV16/64K

RF Tag	ISO 15693 NFC Type V 26kb/s (53kb/s)	EEPROM 16/64K-bit 01001101110000 00110101001110 10110001101110 64-bit password
---------------	---	--



SBN12

Die form, sawn and Bumped inkless 8" wafer, 120µm thickness

Use cases

- Asset tracking, product identification
- Maintenance, repair and operations
- Gaming

Key Features

- **ISO15693** and **NFC Type V**
- **Long range** operations, up to 53kb/s speed
- **16/64K-bit** EEPROM density

Key Benefits

- Temperature range -40°C to +85°C
- Enhanced protection with multiple **64-bit password**
- **40 years** data retention, **1M cycles** erase/write
- Same RF tuning capacitor as in M24LR / ST25DV-I2C (28.5pF)



Low density NFC type 4 tag



ST25TA512B / 02KB

RF Tag	ISO 14443-A	EEPROM 512 / 2K-bit
	NFC Type 4	NDEF
	106kb/s	128-bit password
		20-bit counter
		TruST25 Digital signature



SBN12 / SBN075

Die form, sawn and Bumped inkless 8" wafer, 120µm/75µm thickness

Use cases

- NFC token, NFC tag, Smart poster
- Gaming
- NFC business card (name card, vcard)

Key Features

- **ISO14443-A** Type A and **NFC type 4**
- High speed operations (**106kb/s**)
- **TruST25** digital signature
- Data protection thanks to **128-bit password**
- Counter 20-bit with anti-tearing

Key Benefits

- Optimized PCB footprint
- 50pF internal RF tuning capacitor allowing small antenna design
- **200 years** data retention, **1M cycles** erase/write



ST25TA NFC type 4 tag with GPO



ST25TA02KB-P / -D

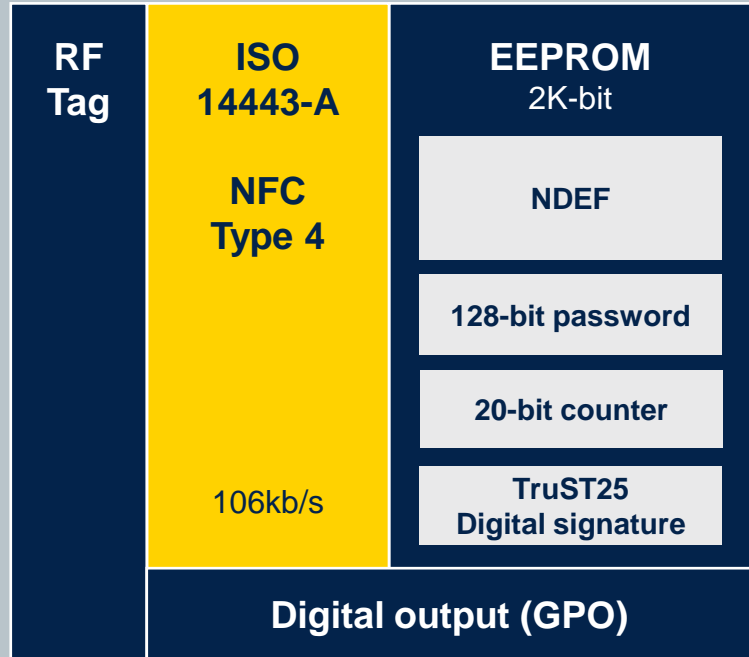

FPN5



SBN12 / SBN075

Die form, sawn and Bumped inkless 8" wafer, 120µm/75µm thickness

Use cases

- Convenient wireless **pairing**
 - Bluetooth pairing
 - Wi-Fi static pairing

Key Features

- **ISO14443-A** Type A and **NFC type 4**
- Data protection thanks to **128-bit** password
- **TruST25** Digital Signature
- **Digital output GPO** feature (for MCU wake-up)
 - -P: CMOS_P GPO (active high, no external resistor)
 - -D: Open Drain GPO (active low, pull-up resistor)

Key Benefits

- Tiny **FPN5** package (1.7x1.4mm)
- 50pF internal RF tuning capacitor allowing small antenna design
- **200 years** data retention, **1M cycles** erase/write



ST25TA

High density NFC type 4 tag



ST25TA16K / 64K

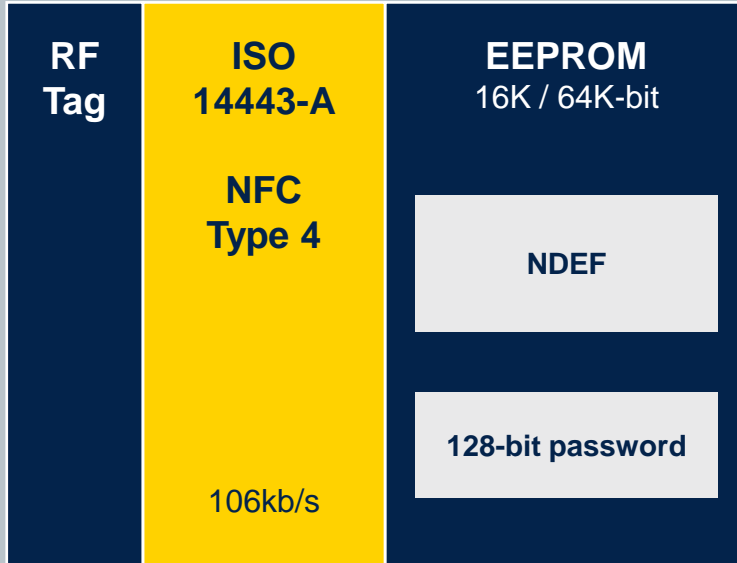

SBN12

Die form, sawn and Bumped inkless 8" wafer, 120µm thickness

Use cases

- Smart poster, Gaming, NFC token
- NFC business card (name card, vcard) with ID picture, web-link and extra digital contents

Key Features

- **ISO14443-A** Type A and **NFC type 4**
- High speed operations (**106kb/s**)
- NDEF memory format
- Data protection thanks to **128-bit password**

Key Benefits

- **Large memory size** (up to 64k-bit)
- Same RF antenna design as M24SR product
- **200 years** data retention, **1M cycles** erase/write



ST25TB RFID tag

ST25TB512 / 02K / 04K

<p>RF Tag</p>	<p>ISO 14443-B</p> <p>106kb/s</p>	<p>EEPROM 512-bit / 2K / 4K-bit</p> <p>01001101110000 00110101001110 10110001101110</p> <p>32-bit counter x2</p> <p>64-bit UID</p>
----------------------	--	---



SBN12

Die form, sawn and Bumped inkless 8" wafer, 120µm thickness

Use cases

- Mass transit and **transport**
- Event ticketing
- Asset tracking
- Brand protection, identification



Key Features

- Fast data transfer (ISO14443-B)
- Large and flexible counting capability with anti-tearing feature
- ST25TB512-AT version dedicated to transport
- 2x counters 32-bit with anti-tearing

Key Benefits

- Temperature range **-40°C to +85°C**
- 40 years data retention, **1M cycles** erase/write



NFC / RFID tags product family

	ST25TB	ST25TN	ST25TA	ST25TV-ANDEF	ST25TV
Contactless Interface	ISO14443B	ISO14443A NFC type 2	ISO14443A NFC type 4	ISO15693 NFC type 5	ISO15693 NFC type 5
RF range	Short range	Short range	Short range	Long range	Long range
RF speed	106kbps	106kbps	106kbps	26kbps (53kbps)	26kbps (53kbps)
Memory format	EEPROM data	EEPROM (preformatted NDEF)	EEPROM (preformatted NDEF)	EEPROM (preformatted NDEF)	EEPROM data
Memory size	512-bit / 2k / 4k-bit	512-bit / 1.6k-bit	512-bit / 2k / 16k / 64k-bit	512-bit / 2k-bit	4k / 16k / 64k-bit
Data protection	OTP bits	Lock blocks	Password 128-bit	Password 64-bit	Password 64-bit
Digital signature	No	Yes, TruST25	Yes, TruST25	Yes, TruST25	No
Digital output	No	No	GPO Field Detect CMOS_P / Open-drain (2k only)	Tamper Detect	GPO Field detect CMOS_P (4k only)
Counter	32-bit (x2)	UTC 24-bit	20-bit	UTC 24-bit	No
Extra features	-	Augmented NDEF	-	Augmented NDEF Untraceable mode	Energy Harvesting (4k only)
RF tuning capacitor	64pF	50pF	50pF / 25pF	23.5pF & 99.7pF	28.5pF
Temperature range	-40°C to +85°C	-40°C to +85°C	-40°C to +85°C	-40°C to +85°C	-40°C to +85°C
Package	SBN12* / SBN075 ²	SBN12* / SBN075 ² FPN5	SBN12*	SBN12* / SBN075 ² FPN5	SBN12*

* SBN12: Die form, sawn and Bumped wafer, 120µm thickness, inkless 8" wafer

² SBN075: Die form, sawn and Bumped wafer, 75µm thickness, inkless 8" wafer

ST25D product ID cards





ST25DV-I2C-EVO

Enhanced dynamic NFC type 5 tag



ST25DV04KC / 16KC / 64KC

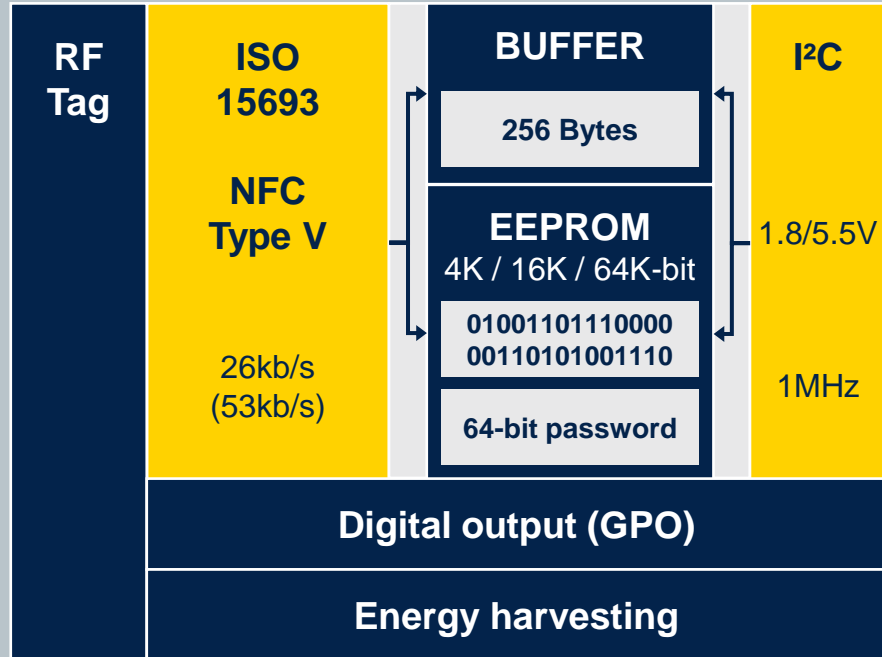

SO8



FPN8



WLCSP10



TSSOP8



FPN12

Use cases

- Fast data exchange with NFC phones / HF readers
 - Fast data transfer for MCU FW upgrade, fast data exchange
 - Parameters settings and update, with in-the-box programming
 - Data log download

Key Features

- **ISO15693** and **NFC Type V**
- **Fast data transfer** thanks to 256 Bytes buffer
- I2C write on **16-Byte page**
- Low Power mode, < 1µA power consumption in Standby
- -40 to +125°C (I2C) industrial Grade 8 temperature range
- **Energy harvesting** function through RF
- I2C enhanced features (write time improved, address configurable, access priority...)

Key Benefits

- Smart applications using a **flexible interrupt GPO**
- Enhanced protection with multiple **64-bit passwords**
- Same 28.5pF internal RF tuning capacitor, as in ST25DV-I2C & M24LR





ST25DV-PWM Dynamic NFC type 5 tag with PWM



ST25DV02K-W1 / -W2

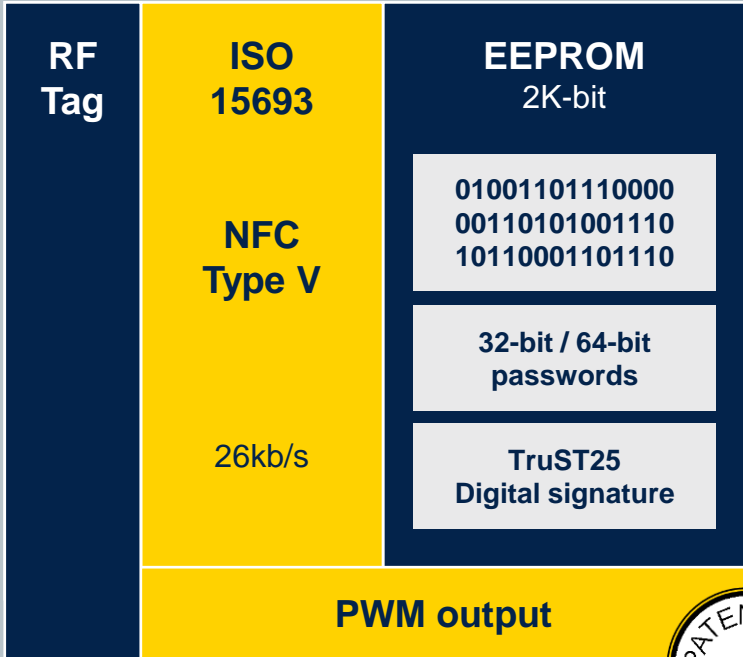

SO8



TSSOP8

Use cases

- Targeted industrial applications such as Lighting LED driver, Motor control, Power supply unit



Key Features

- **ISO15693** and **NFC Type V**
- 2K-bit memory
- Up to **2 PWM** signal (push pull)
- Up to 15 bits resolution (62.5ns resolution step)
- Power Supply 1.8V - 5.5V
- -40°C to **+105°C** (PWM) temperature range
- **TruST25 Digital Signature**

Key Benefits

- 2 in 1 chip, putting NFC connectivity with PWM functionality
- Cost optimized solution to address low end Lighting market
 - Significant BOM reduction as no MCU is required to drive the system





ST25DV-I2C

Dynamic NFC type 5 tag



ST25DV04K / 16K / 64K

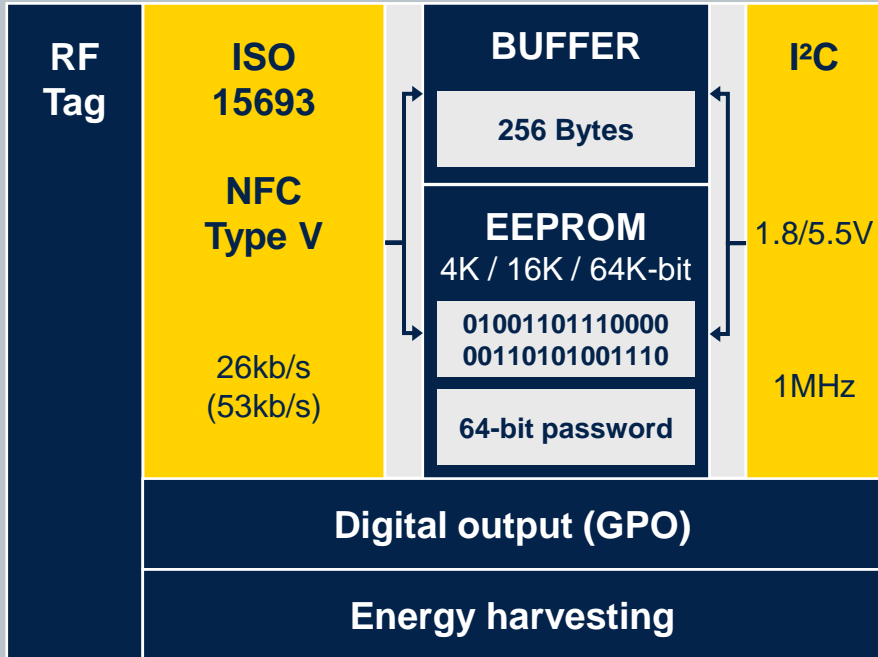

SO8



FPN8



FPN12



TSSOP8



WLCSP10

Use cases

- Fast data exchange with NFC phones / HF readers
 - Fast data transfer for MCU FW upgrade, fast data exchange
 - Parameter settings and update, with in the box programming
 - Datalog download

Key Features

- **ISO15693** and **NFC Type V**
- **Fast data transfer** thanks to 256 Bytes buffer
- Low Power mode, < 1µA power consumption in Standby
- -40 to +125°C (I2C) industrial Grade 8 temperature range
- **Energy harvesting** function through RF

Key Benefits

- Smart applications using a **flexible interrupt GPO**
- Enhanced protection with multiple **64-bit passwords**
- Same 28.5pF internal RF tuning capacitor, as in M24LR





M24SR Dynamic NFC type 4 tag



M24SR02 / 04 / 16 / 64

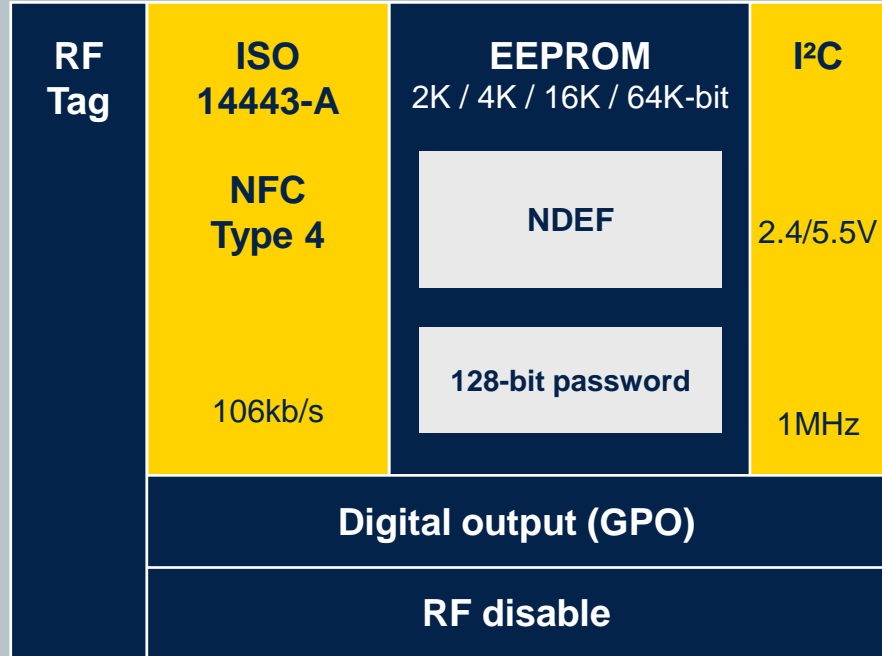

SO8



TSSOP8



FPN8



SBN12

Die form, sawn and Bumped inkless 8" wafer, 120µm/ thickness

Use cases

- Convenient wireless pairing (Bluetooth, Wi-Fi)
- Dynamic data exchange with NFC phone
 - User settings update, information log download,...

Key Features

- ISO14443-A Type A and NFC Type 4
- High speed operations (**106kb/s**)
- NDEF memory format
- Data protection thanks to **128-bit password**

Key Benefits

- Easy of use (limited BOM, 8-pin package)
- Flexible interrupt pin (configurable GPO)
- **200 years** data retention, **1M cycles** erase/write



M24LR

Dynamic NFC / RFID type 5 tag

M24LR04E / 16E / 64E

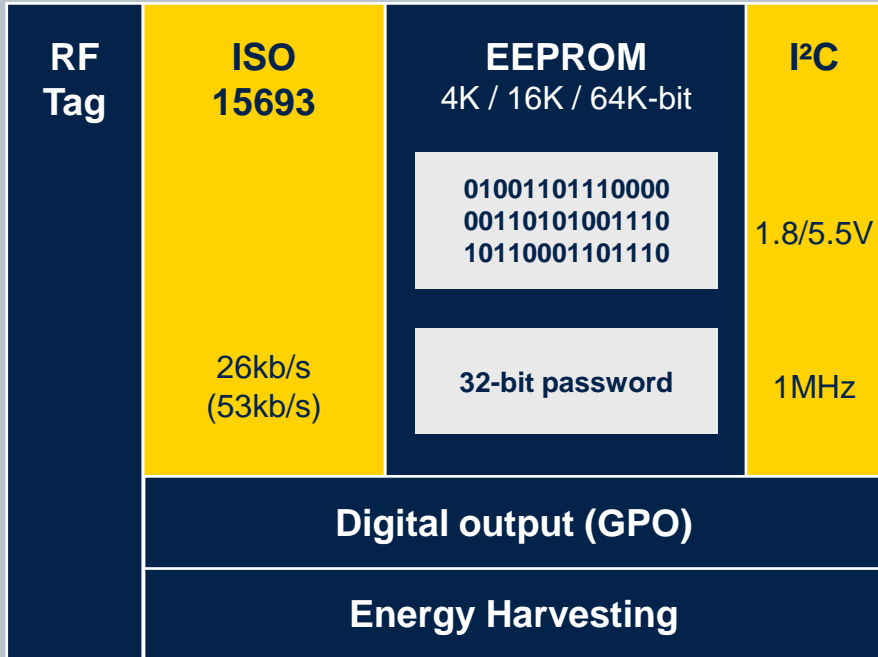

SO8



FPN8



TSSOP8

Use cases

- Dynamic data exchange with NFC phone
- Battery-less applications
- Parameter upgrade with RFID readers

Key Features

- **ISO15693**
- **Long range** operations, up to 53kb/s speed
- **Energy harvesting** through RF (~2V / 5mA)

Key Benefits

- Easy of use (limited BOM, 8-pin package)
- Flexible interrupt pin for MCU wake-up
- Cost optimized discovery kit with Android app
- 40 years data retention, **1M cycles** erase/write



Dynamic NFC / RFID tags product family

	M24SR	M24LR	ST25DV-I2C	ST25DV-I2C EVO	ST25DV-PWM
Contactless Interface	ISO14443A NFC Type 4	ISO15693 NFC compatible	ISO15693 NFC Type 5	ISO15693 NFC Type 5	ISO15693 NFC Type 5
RF range	Short range (up to 10cm)	Long range (up to 1m)	Long range (up to 1m)	Long range (up to 1m)	Long range (up to 1m)
RF speed	106kbps	26kbps	26kbps	26kbps	26kbps
Serial Interface	I2C @1MHz	I2C @400kHz Write 4-Byte page size	I2C @1MHz Write 4-Byte page size	I2C @1MHz Write 16-Byte page size	No
Fast Transfer Mode	No	No	Yes (256B buffer)	Yes (256B buffer)	No
Energy Harvesting	No	Yes	Yes	Yes	No
Digital output	Open-Drain GPO	Open-Drain GPO	OD or CMOS GPO	OD or CMOS GPO	2x PWM
Extra features	RF Disable	-	Low Power mode	Low Power mode	-
Memory format	EEPROM (preformatted NDEF)	EEPROM data	EEPROM data	EEPROM data	EEPROM data
Memory size	2k / 4k / 16k / 64k-bit	4k / 16k / 64k-bit	4k / 16k / 64k-bit	4k / 16k / 64k-bit	2k-bit
Data protection	Password 128-bit	Password 32-bit	Password 64-bit	Password 64-bit	Password 64-bit Digital signature
Temperature range	-40°C to +105°C	-40°C to +85°C	-40°C to +125°C	-40°C to +125°C	-40°C to +105°C
Package	SO8 / TSSOP8 / FPN8 / SBN12*	SO8 / TSSOP8 / FPN8	SO8 / TSSOP8 / FPN8 / FPN12 / WLCSP10	SO8 / TSSOP8 / FPN8 / FPN12 / WLCSP10	SO8 / TSSOP8

* SBN12: Die form, sawn and Bumped wafer, 120µm thickness, inkless 8" wafer

ST25R product ID cards



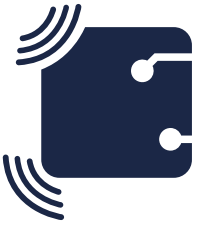

Entry level NFC reader solution

ST25R95

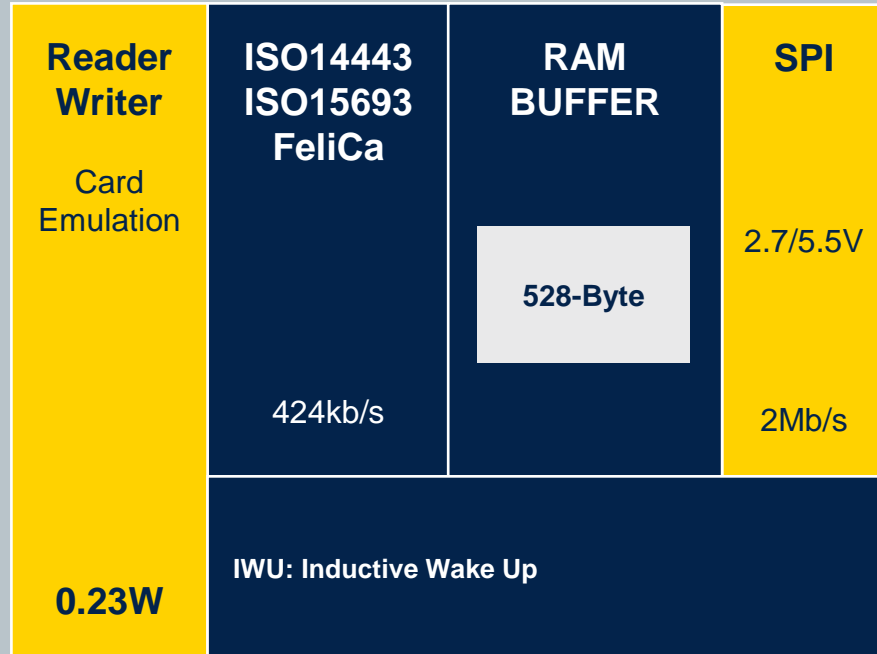

QFN32

Use cases

- Smart Locks, Card Readers
- Gaming and Toys
- Dynamic wireless pairing with hand-over

Key Features

- **Reader-Writer (R/W)** and **Card Emulation (CE)**
- All NFC modes supported (ISO14443, ISO15693, FeliCa)
- Fast data transfer (up to **424kb/s**)
- 0.23W output power

Key Benefits

- Simple implementation
- Easy-to-use evaluation with development kits
- Reference designs, application notes
- Cost effective solution

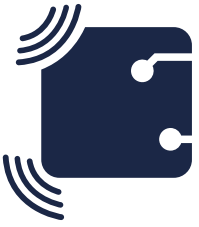

ST25R3911B

1.4W high power payment reader solution



ST25R3911B

Reader Writer	ISO14443 ISO15693 FeliCa	RAM BUFFER	SPI
AP2P Initiator & Target PP2P Initiator	NFC 6.8Mb/s	96-Byte	2.4/5.5V 6Mb/s
1.4W	VHBR: Very High Baud Rate DPO: Dynamic Power Output CIWU: Capacitive & Inductive Wake Up AAT: Automatic Antenna Tuning		



QFN32



Wafer

Use cases

- Ideal for **Payment** applications
- Access Control, Gaming, eGovernment passport

Key Features

- All NFC modes supported (ISO14443, ISO15693, FeliCa) with P2P
- **1.4W** output power
- **EMVCo 2.6 & PBOC** certification without external power amplifier
- Automatic Antenna Tuning
- **VHBR** support up to **6.8Mb/s**
- -40°C to **125°C** junction temperature range

Key Benefits

- Low power operation & Stand-by mode (capacitive wake-up)
- 2 antennas operation at the same time
- Enhanced fast transfer rate for Passport application



Smallest footprint, high power reader solution



ST25R3912

Reader Writer	ISO14443 ISO15693 FeliCa	RAM BUFFER	SPI
AP2P Initiator & Target PP2P Initiator	NFC 848kb/s	96-Byte	2.4/5.5V 6Mb/s
1W	DPO: Dynamic Power Output IWU: Inductive Wake Up		



QFN32
Wettable flank



WLCSP

Use cases

- Ideal for EMVCo 2.6 legacy **Payment** and **small handheld mPOS**
- Access Control
- Gaming

Key Features

- All NFC modes supported (ISO14443, ISO15693, FeliCa) with P2P
- **1W** output power
- **EMVCo 2.6 & PBOC** certification without external power amplifier
- Small 3x2.8 **WLCSP** package
- -40°C to **125°C** junction temperature range

Key Benefits

- Small Footprint on PCB, Low power operation & Stand-by mode
- 2 antennas operation at the same time

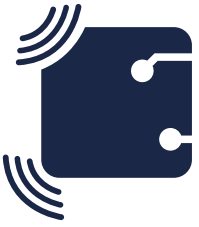

ST25R3914/15

High power automotive reader solution



ST25R3914/15

Reader Writer AP2P Initiator & Target PP2P Initiator 1W	ISO14443 ISO15693 FeliCa NFC 848kb/s	RAM BUFFER 96-Byte	SPI 2.4/5.5V 6Mb/s
AEC-Q100 qualification DPO: Dynamic Power Output CIWU: Capacitive & Inductive Wake Up AAT: Automatic Antenna Tuning			



QFN32



QFN32
Wettable flank

Use cases

- Ideal for **Automotive** applications
 - Keyless entry and start according to **CCC Digital Key**
 - NFC enhanced Foreign Object Detection for Qi wireless charging

Key Features

- All NFC modes supported (ISO14443, ISO15693, FeliCa) with P2P
- **Automotive AEC-Q100** certified
- **1W** output power
- Automatic Antenna Tuning (ST25R3914 only)
- -40°C to **125°C** junction temperature range

Key Benefits

- Low power operation & Stand-by mode (capacitive wake-up)
- 2 antennas operation at the same time
- Reliable performance even in metallic environment



ST25R3916B

High-perf. NFC universal device & EMVCo reader



ST25R3916B

Reader Writer AP2P PP2P Card Emulation 1.6W	ISO14443 ISO15693 FeliCa NFC 848kb/s	RAM BUFFER <div style="border: 1px solid black; padding: 5px; text-align: center;">512-Byte</div>	SPI/I²C 2.4/5.5V 3.4Mb/s 10Mb/s
	DPO: Dynamic Power Output IWU: Inductive Wake Up (LPCD) AWS: Active Wave shaping NSR: Noise Suppression Receiver AAT: Automatic Antenna Tuning DSO: Driver Slope Adjustment EMD: Automatic EMD Error Handling		



QFN32
Wettable flank



WLCSP

Use cases

- Ideal for **Payment** applications with CE mode for additional functions
- Apple ECP, Access Control, Gaming, IOT and pairing

Key Features

- NFC Forum Universal Device (with CE mode)
- **1.6W** output power with **Dynamic Power Output**
- **EMVCo 3.1a** certification without external power amplifier
- Improved **Active Waveshaping v2, Noise Suppression Receiver**
- **Automatic Antenna Tuning**
- -40°C to **105°C** ambient temperature range (QFN)

Key Benefits

- Low power operation & Standby mode (low power card detection)
- Works in challenging environment like noisy LCD displays
- Ideal for passing newest EMVCo standards

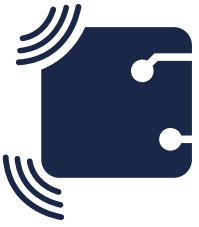

Cost efficient - performant NFC & EMVCo reader



ST25R3917B

Reader Writer PP2P Initiator 1.6W	ISO14443 ISO15693 FeliCa NFC 848kb/s	RAM BUFFER <div style="border: 1px solid black; padding: 5px; width: fit-content; margin: 0 auto;">512-Byte</div>	SPI/I²C 2.4/5.5V 3.4Mb/s 10Mb/s
	DPO: Dynamic Power Output IWU: Inductive Wake Up AWS: Active Wave shaping NSR: Noise Suppression Receiver DSO: Driver Slope Adjustment EMD: Automatic EMD Error Handling		



QFN32
Wettable flank

Use cases

- Ideal for **Payment** applications
- Apple ECP, Access Control, Gaming, Consumer

Key Features

- NFC Forum Reader device
- **1.6W** output power with **Dynamic Power Output**
- **EMVCo 3.1a** certification without external power amplifier
- Improved **Active Waveshaping v2, Noise Suppression Receiver**
- -40°C to **105°C** ambient temperature range

Key Benefits

- Low power operation & Standby mode (low power card detection)
- Works in challenging environment like noisy LCD displays
- Ideal for passing newest EMVCo standards

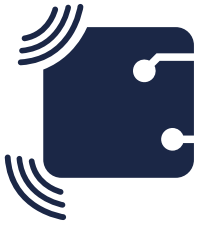

ST25R3918

Multi-purpose NFC Transceiver



ST25R3918

Reader Writer	ISO14443 ISO15693	RAM BUFFER	SPI/I²C
PP2P Initiator & Target Card Emulation	NFC 848kb/s	512-Byte	2.4/5.5V 3.4Mb/s 10Mb/s
0.5W	DPO: Dynamic Power Output IWU: Inductive Wake Up AWS: Active Wave shaping NSR: Noise Suppression Receiver DSO: Driver Slope Adjustment EMD: Automatic EMD Error Handling		



QFN32
Wettable flank

Use cases

- Ideal for **Reader+Tag** applications
- Access Control, Gaming, Consumer
- Apple AppClip, Android InstantApp

Key Features

- **0.5W** output power
- **Active Waveshaping**
- **Noise Suppression Receiver**
- -40°C to **105°C** ambient temperature range

Key Benefits

- Low power operation & Standby mode
- Works in challenging environment like noisy LCD displays
- Excellent performance for low power applications

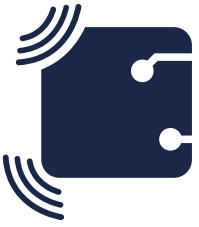

ST25R3920B

High-perf AEC-Q100 NFC universal device



ST25R3920B

Reader Writer	ISO14443 ISO15693 FeliCa	RAM BUFFER	SPI/I²C
AP2P Initiator & Target		NFC	
PP2P Initiator & Target	848kb/s		2.4/5.5V
Card Emulation	DPO: Dynamic Power Output CIWU: Capacitive & Inductive Wake Up AWS: Active Wave shaping NSR: Noise Suppression Receiver AAT: Automatic Antenna Tuning DSO: Driver Slope Adjustment EMD: Automatic EMD Error Handling		5Mb/s 3.4Mb/s
1.6W			



QFN32
Wettable flank

Use cases

- Ideal for **CCC Digital Key** applications
- IOT and pairing in the car

Key Features

- NFC Forum Device
- **1.6W** output power with **Dynamic Power Output**
- Improved **Active Waveshaping v2**
- Automatic Antenna Tuning
- **Noise Suppression Receiver**
- -40°C to **105°C** ambient temperature range

Key Benefits

- Low power operation & Standby mode (capacitive wake-up)
- Works in challenging environment like small antennas

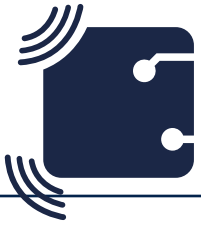

ST25R NFC / HF readers product family

	ST25R95	ST25R3911B	ST25R3912	ST25R3914/15	ST25R3916B/17B	ST25R3918	ST25R3920B
Description	Entry-Level NFC Reader	High-Performance NFC Forum Reader	Mid-Range NFC Forum Reader	Automotive Grade NFC Forum Reader	High-performance NFC & EMVCo Reader	Multi-purpose NFC transceiver	Automotive Grade NFC Forum Reader
Reader/Writer mode	ISO14443A/B ISO15693 Felica	ISO14443A/B ISO15693 FeliCa	ISO14443A/B ISO15693 FeliCa	ISO14443A/B ISO15693 FeliCa	ISO14443A/B ISO15693 FeliCa	ISO14443A/B ISO15693	ISO14443A/B ISO15693 FeliCa
Card emulation mode	Yes	-	-	-	Yes (16B)	Yes	Yes
AP2P mode	-	Initiator & Target	Initiator & Target	Initiator & Target	Initiator & Target (16B)	-	Initiator & Target
PP2P mode	-	Initiator	Initiator	Initiator	Initiator & Target (16B)	Initiator & Target	Initiator & Target
RF speed	424kbps	6.8Mbps (VHBR)	848kbps	848kbps	848kbps	848kbps	848kbps
Market	Consumer	Payment EMVCo 2.6, Industrial	Access control, Metering, Consumer	Automotive AEC-Q100 grade 1	Payment EMVCo 3.1, Industrial, Consumer	Reader+Tag, IoT, Gaming, Consumer	Automotive AEC-Q100 grade 1
Advanced features	IWU	AAT, DPO, CIWU	DPO, IWU	AAT (14), DPO, CIWU	AAT (16B), DPO, NSR, DSA, AWS, IWU, EMD	DPO, NSR, DSA, AWS, IWU, EMD	AAT, DPO, NSR, DSA, AWS, CIWU, EMD
HW interface	SPI 2Mbps	SPI 6Mbps	SPI 6Mbps	SPI 6Mbps	I ² C & SPI 10Mbps	I ² C & SPI 10Mbps	I ² C & SPI 10Mbps
SW interface	 Unified Software Library for NFC Front Ends						
Power supply	2.7V - 5.5V	2.4V – 5.5V	2.4V – 5.5V	2.4V – 5.5V	2.4V – 5.5V	2.4V – 5.5V	2.4V – 5.5V
Output power	0.23W	1.4W	1.0W	1.0W	1.6W	0.5W	1.6W
Temp range	-25°C to +85°C	-40°C to +125°C ^(J)	-40°C to +125°C ^(J)	-40°C to +125°C ^(J)	-40°C to +105°C	-40°C to +105°C	-40°C to +105°C
Package	32-pin QFN	32-pin QFN / Wafer	32-pin QFN / WF 32-pin QFN / WLCSP-30	32-pin QFN / WF 32-pin QFN	(WF) 32-pin QFN / WLCSP-36	WF 32-pin QFN	WF 32-pin QFN



VHBR: Very High Baud Rate
 P2P: Peer to Peer mode
 AAT: Automatic Antenna Tuning
 AWS: Active Wave Shaping

EMD: Automatic EMD suppression
 VHBR: Very High Baud Rate
 DPO: Dynamic Power Output
 CIWU: Capacitive & Inductive Wakeup

DSA: Drive Slope Adjustment
 (J) Junction
 NSR: Noise Suppression Receiver
 IWU: Inductive Wakeup

ST25RU product ID card



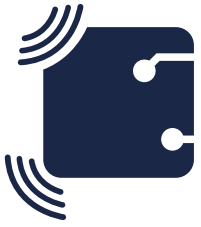

ST25RU3993 UHF RFID reader



ST25RU3993

UHF Reader	EPC Class1 Gen2	FIFO	SPI
Receive Sensitivity -90 dBm Two Output Types Linear: 0dBm PA: 20dBm	ISO18000-62 ISO18000-63 GB/T 29768	<div style="border: 1px solid black; padding: 5px; text-align: center;">24-Byte</div>	1.65/5.5V 5Mb/s
	Internal VCO (Voltage Controlled Oscillator) Dense Reader Mode Linear RSSI & Phase Bit Automatic PSRR regulation Auto ACK		
Digital output (IRQ)			



QFN48

Use cases

- **Retail**, Stationary readers
- Industrial PDA's, Authentication, Portable Data Capture
- Tablets / Smartphones, Dongles / Snap Ons, Handheld readers

Key Features

- Tuneable frequency 840MHz to 960MHz
- **Dense Reader Mode filtering** on board
- Single ended Rx and differential input
- Adjustable linear output 0dBm and internal power amplifier adjustable 20dBm
- Receive sensitivity of **-90dBm**
- Power consumption down to 65mA, Power Down Mode with 3.3µW
- **950 tags/s** single tag read speed @ 2 bytes EPC length, 640 kHz, FM0

Key Benefits

- Ideal for **mobile** applications and works in a dense reader environment
- Prolonging battery life & robust against poor antenna

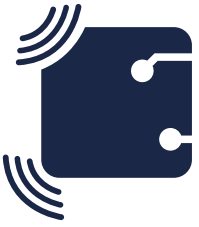

ST25RU UHF reader

ST25RU3993

Description	UHF RFID Reader for Mobile and Fast Moving Consumer Goods applications
Protocols	EPC Class1 Gen2 , ISO18000-62 & -63 , ISO29143, GB/T 29768 transparent mode: custom protocols possible
Modulation modes	Double Side Band (DSB) transmit modulation Phase Reversal Amplitude Shift Keying (PR-ASK) transmit modulation
Tunable frequency	840 to 960MHz
Power supply	1.65V – 5.5V
Power consumption <i>normal / standby / power-down</i>	210mW / 9.9mW / 3.3μW
Communication interface	Serial Peripheral Interface (SPI) 5Mbps
Sensitivity (IC)	-90dBm
Output power <i>linear for external PA / internal PA</i>	0dBm / 20dBm (1dB steps)
Read speed <i>single / unique</i>	950 tags/s , 440 tags/s
Advanced features	Dense Reader Mode, Internal Voltage Controlled Oscillator (VCO), Linear Received Signal Strength Indication (RSSI) & Phase Bit, Automatic Power Supply Rejection Ratio (PSRR) regulation, Auto Acknowledge (ACK), Transparent Mode
Temperature range	-40 to +85°C
Package	48-pin QFN (7x7mm)

ST25 product part numbers





ST25T part numbers

ST25T NFC / RFID Tags



ST25TA	Package	512-bit	2k-bit		16k-bit	64k-bit
NFC Type 4 Tag ISO14443-A (+GPO)	SBN12 SBN075 UFD5FN5 UFD5FN5	ST25TA512B-AC6G5 ST25TA512B-AC6F5	ST25TA02KB-AC6G5 ST25TA02KB-AC6F5 ST25TA02KB-PC6H5 ST25TA02KB-DC6H5		ST25TA16K-AB6G3	ST25TA64K-AB6G3
ST25TB	Package	512-bit	2k-bit	4k-bit		
RFID Tag ISO14443-B	SBN12 SBN12 SBN075	ST25TB512-AC6G6 ST25TB512-AT6G6 ST25TB512-AT6F6	ST25TB02K-AC6G6	ST25TB04K-AC6G6		
ST25TN	Package	512-bit	1.6k-bit			
NFC Type 2 Tag ISO14443-A	SBN12 SBN075 UFD5FN5	ST25TN512-AFG5	ST25TN01K-AFG5 ST25TN01K-AFF5 ST25TN01K-AFH5			
ST25TV	Package	512-bit	2k-bit	4k-bit	16k-bit	64k-bit
NFC Type 5 Tag ISO15693 (+ Tamper Detect)	SBN12 SBN12 SBN075 UFD5FN5 SBN12 SBN12 SBN075 UFD5FN5	ST25TV512C-AFG3 ST25TV512C-AFF3 ST25TV512-AP6G9 ST25TV512-AD6G9 ST25TV512-AP6F9	ST25TV02KC-AFG3 ST25TV02KC-TFG3 ST25TV02KC-AFF3 ST25TV02KC-TFH3 ST25TV02K-AP6G9 ST25TV02K-AD6G9 ST25TV02K-AP6F9 ST25TV02K-AD6H9	ST25TV04K-PE6G3	ST25TV16K-AP6G3	ST25TV64K-AP6G3



ST25D part numbers (1/2)

ST25D Dynamic NFC Tags

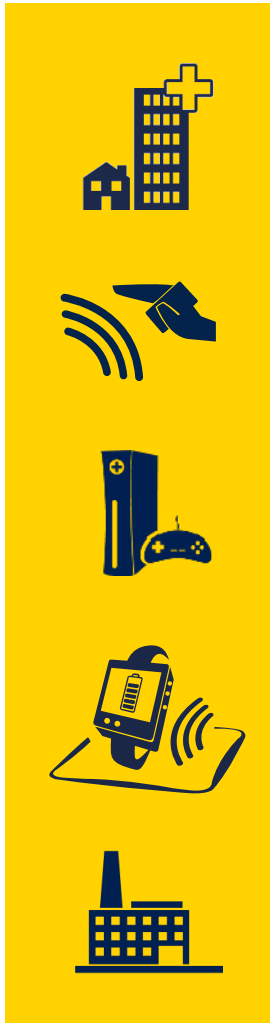

ST25DV-I2C EVO	Package		4k-bit	16k-bit	64k-bit
Dynamic NFC Type 5 Tag ISO15693 + I2C IF (16Bytes write) + GPO + Fast Transfer Mode + Energy Harvesting + Extended Temperature	SO8 SO8 TSSOP8 TSSOP8 UFDFPN8 UFDFPN8 UFDFPN12 UFDFPN12 WLCSP10		ST25DV04KC-IE6S3 ST25DV04KC-IE8S3 ST25DV04KC-IE6T3 ST25DV04KC-IE8T3 ST25DV04KC-IE6C3 ST25DV04KC-IE8C3 ST25DV04KC-JF6D3 ST25DV04KC-JF8D3 ST25DV04KC-JF6L3	ST25DV16KC-IE6S3 ST25DV16KC-IE8S3 ST25DV16KC-IE6T3 ST25DV16KC-IE8T3 ST25DV16KC-IE6C3 ST25DV16KC-IE8C3 ST25DV16KC-JF6D3 ST25DV16KC-JF8D3	ST25DV64KC-IE6S3 ST25DV64KC-IE8S3 ST25DV64KC-IE6T3 ST25DV64KC-IE8T3 ST25DV64KC-IE6C3 ST25DV64KC-IE8C3 ST25DV64KC-JF6D3 ST25DV64KC-JF8D3
ST25DV-I2C	Package		4k-bit	16k-bit	64k-bit
Dynamic NFC Type 5 Tag ISO15693 + I2C IF (4Bytes write) + GPO + Fast Transfer Mode + Energy Harvesting + Extended Temperature	SO8 SO8 TSSOP8 TSSOP8 UFDFPN8 UFDFPN8 UFDFPN12 UFDFPN12 WLCSP10		ST25DV04K-IER6S3 ST25DV04K-IER8S3 ST25DV04K-IER6T3 ST25DV04K-IER8T3 ST25DV04K-IER6C3 ST25DV04K-IER8C3 ST25DV04K-JFR6D3 ST25DV04K-JFR8D3 ST25DV04K-JFR6L3	ST25DV16K-IER6S3 ST25DV16K-IER8S3 ST25DV16K-IER6T3 ST25DV16K-IER8T3 ST25DV16K-JFR6D3	ST25DV64K-IER6S3 ST25DV64K-IER8S3 ST25DV64K-IER6T3 ST25DV64K-IER8T3 ST25DV64K-JFR6D3 ST25DV64K-JFR8D3
ST25DV-PWM	Package	2k-bit			
Dynamic NFC Type 5 Tag ISO15693 + 1x or 2x PWM IF + Extended Temperature	SO8 SO8 TSSOP8 TSSOP8	ST25DV02K-W1R8S3 ST25DV02K-W2R8S3 ST25DV02K-W1R8T3 ST25DV02K-W2R8T3			



ST25D part numbers (2/2)

ST25D Dynamic NFC Tags

M24SR	Package	2k-bit	4k-bit	16k-bit	64k-bit
Dynamic NFC Type 4 Tag ISO14443-A I2C IF + GPO + RF disable + Extended Temperature	SO8 TSSOP8 UFDFPN8 SBN12 SO8 TSSOP8	M24SR02-YMN6T/2 M24SR02-YDW6T/2 M24SR02-YMC6T/2 M24SR02-YSG12I/2	M24SR04-YMN6T/2 M24SR04-YDW6T/2 M24SR04-YMC6T/2	M24SR16-YMN6T/2 M24SR16-YDW6T/2 M24SR16-YMC6T/2	M24SR64-YMN6T/2 M24SR64-YDW6T/2 M24SR64-YMC6T/2 M24SR64-YSG12I/2 M24SR64-YMN8T/2 M24SR64-YDW8T/2
M24LR	Package		4k-bit	16k-bit	64k-bit
Dynamic NFC Type 5 Tag ISO15693 + I2C IF + GPO + EH	SO8 TSSOP8 UFDFPN8		M24LR04E-RMN6T/2 M24LR04E-RDW6T/2 M24LR04E-RMC6T/2	M24LR16E-RMN6T/2 M24LR16E-RDW6T/2 M24LR16E-RMC6T/2	M24LR64E-RMN6T/2 M24LR64E-RDW6T/2 M24LR64E-RMC6T/2

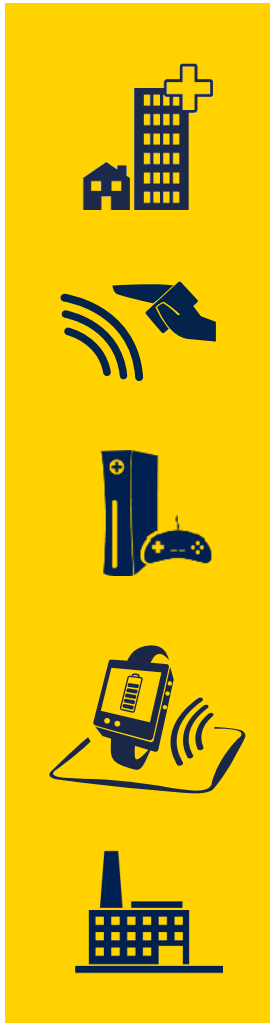

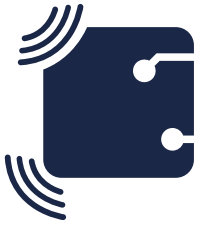

ST25R part numbers

ST25R HF NFC / RFID Readers

ST25R95	Package	Features	Part Number
Entry-Level HF Readers	QFN32	R/W & CE, IWU	ST25R95-VMD5T
ST25R3911B/12	Package	Features	Part Number
High-Perf HF Readers for Industrial and Consumer	QFN32 Wafer WF QFN32 WLCSP30	R/W, VHBR, AAT, DPO, CIWU R/W, VHBR, AAT, DPO, CIWU R/W, DPO, IWU R/W, DPO, IWU	ST25R3911B-AQFT ST25R3911B-ASWB ST25R3912-AQWT ST25R3912-AWLT
ST25R3914/15	Package	Features	Part Number
High Power Readers for Automotive	WF QFN32 QFN32	R/W, AAT, DPO, CIWU R/W, DPO, CIWU	ST25R3914-AQWT ST25R3915-AQFT
ST25R3916B/17B	Package	Features	Part Number
High-Perf NFC Universal Devices & EMVCo Readers	WF QFN32 WLCSP36 WF QFN32	R/W & CE, AAT, DPO, CIWU, AWS R/W & CE, AAT, DPO, CIWU, AWS R/W, DPO, CIWU, AWS	ST25R3916B-AQWT ST25R3916B-AQET ST25R3916B-BWLT ST25R3917B-AQWT ST25R3917B-AQET
ST25R3918	Package	Features	Part Number
Multi-purpose NFC transceiver	WF QFN32	R/W & CE, DPO, IWU, AWS	ST25R3918-AQWT
ST25R3920B	Package	Features	Part Number
High-Perf AEC-Q100 NFC Universal Device	WF QFN32	R/W & CE, AAT, DPO, CIWU, AWS	ST25R3920B-AQWT



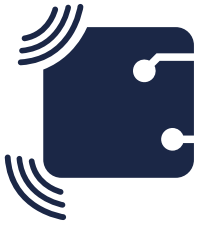

ST25RU part number

ST25RU UHF RFID Readers

ST25RU3993	Package	Features	Part Number
UHF Readers for Handheld devices	QFN48	Dense reader mode	ST25RU3993-BQFT



ST25 HW evaluation boards





ST25-TAG-BAG-UB

ST25 Tag Bag AME

ST life.augmented NFC Type5 ST25TV Tag Evaluation Kit



ST25-TAG-BAG-AB

ST25 Tag Bag APAC

ST life.augmented talkin' things

ST25-TAG-BAG-EC



ST25-TAG-BAG-EC

ST25 Tag Bag EMEA

Manufactured by SAG





ST25TV-ANDEF evaluation board



ST25TV02KC-ASEAL

ST25TV02KC ASEAL board

- **ST25TV02KC** NFC/RFID tag IC
- UDFPN5 package
- Class-6 18 turns single layer antenna
- 256-Byte (2-kbit) NDEF EEPROM
- Tamper detect capability
- TruST25 digital signature
- Augmented NDEF (ANDEF)



ST25DV-PWM evaluation board

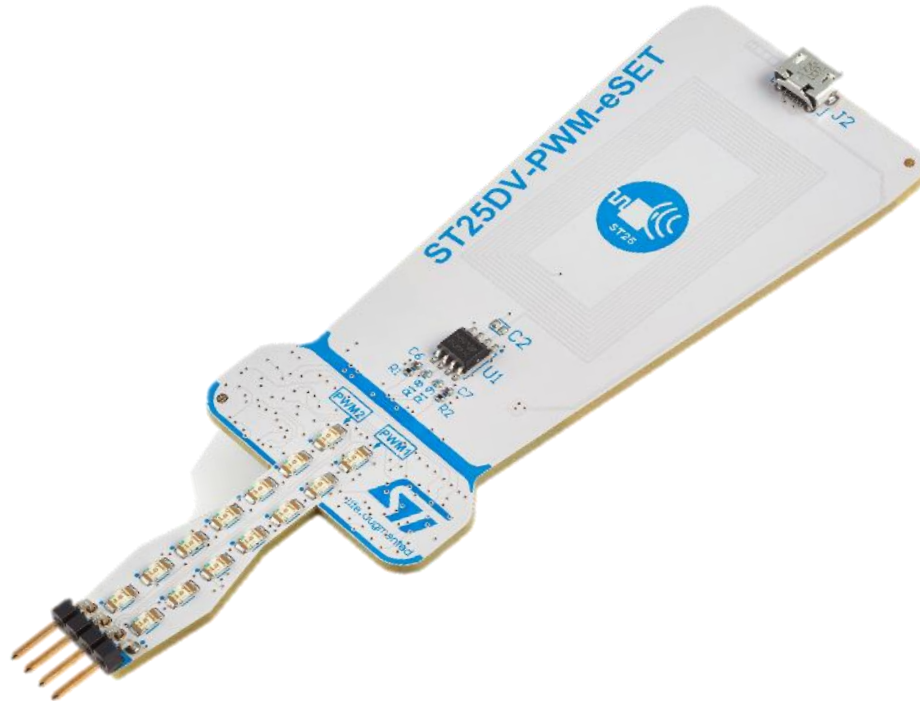

ST25DV-PWM-eSET

ST25DV-PWM discovery kit

- **ST25DV02K-W2** dynamic NFC tag IC
- 49x26mm 8 turns antenna
- PWM frequency and duty cycle through Android App or PC Software
- Duty cycle illustration with LED ramp
- Connector to ST25DV-DISCOVERY kit to monitor the PWM signal on display



ST25DV-I2C-EVO evaluation boards

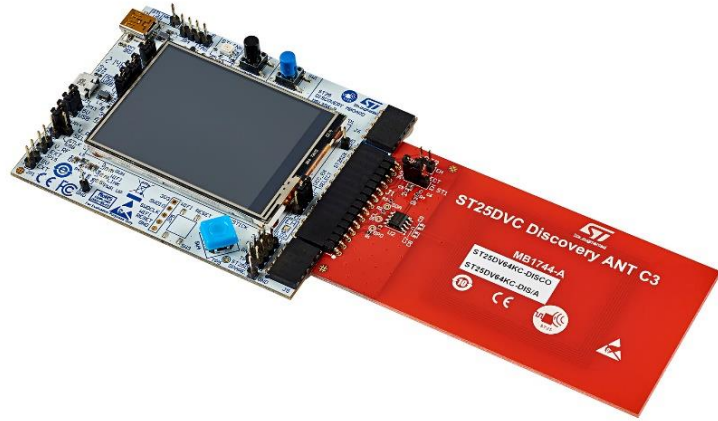

ST25DV64KC-DISCO

ST25DV-I2C-EVO discovery kit

- **ST25DV64KC** Dynamic NFC tag IC
- 49x37mm 8 turns antenna (ANT Class3)
- STM32F405 MCU
- I2C & SWIP connectors
- 14.5x24mm 15 turns antenna (Flex)
- 5 samples ST25DV64KC



X-NUCLEO-NFC07A1



ST25DV-I2C-EVO Nucleo shield

- **ST25DV64KC** Dynamic NFC tag IC
- Ø54mm 8 turns single layer antenna Energy harvesting, Low Power mode, GPO
- Compatible with STM32 Nucleo boards
- I2C interface to MCU & Powered through Arduino™ connector



ANT7-T-25DV64KC

ST25DV-I2C-EVO tiny antenna

- **ST25DV64KC** Dynamic NFC tag IC
- Ready-to-use PCB including:
- 14x14 mm, dual layer etched antenna
- I2C test points
- RF event configurable GPO
- Analog energy harvesting (EH) output



NFC sensor tag evaluation board

NFC Dynamic Tag sensor and processing node

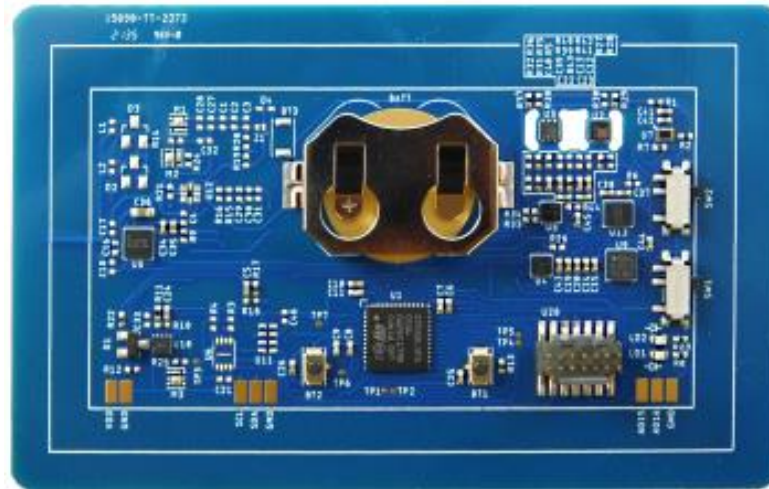
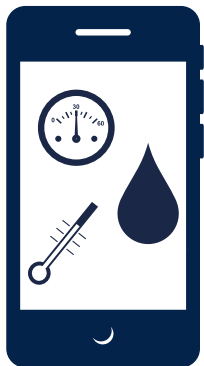

STEVAL-SMARTAG2

NFC Sensor Tag

- **ST25DV64KC** dynamic NFC tag
- STM32L4 ultra-low-power MCU
- LIS2DUXS12 ultra-low-power 3-axis smart accelerometer
- H3LIS331DL low power High-g 3-axis accelerometer
- LPS22DF nano pressure sensor
- VD6283TX ambient light sensor
- 40x40mm 8 turns antenna
- Optional CR2032 / LIR2032 battery



M24SR evaluation boards



M24SR-DISCO-PREM

M24SR discovery kit

- **M24SR64** Dynamic NFC Tag IC
- 30x30mm 5 turns double layer antenna
- STM32F1 MCU
- LCD Color display + Joystick + LEDs
- USB & JTAG connectors
- BT / Audio module with audio headset



X-NUCLEO-NFC01A1



M24SR Nucleo shield

- **M24SR64** Dynamic NFC Tag IC
- 31x30mm 5 turns double layer antenna
- Compatible with STM32 Nucleo boards
- I2C interface to MCU through Arduino™ connector
- Open drain output for MCU wake-up



ANT7-T-M24SR64

M24SR tiny antenna

- **M24SR64** Dynamic NFC Tag IC
- 14x14mm dual layer antenna
- I2C test points to connect to MCU
- GPO open drain user configurable output to indicate an ongoing RF operation

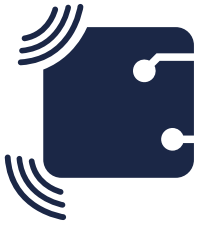

ST25R95 / CR95HF evaluation boards

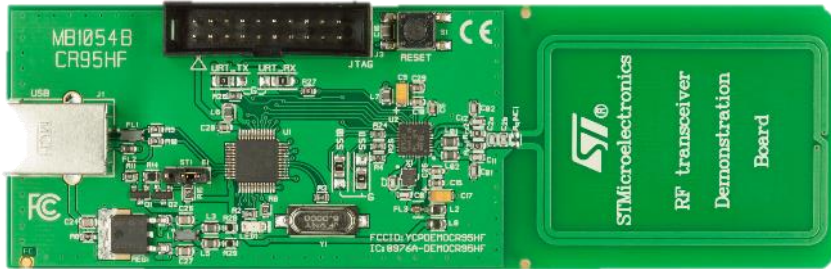

M24LR-DISCOVERY

CR95HF demo board

- **CR95HF** NFC multi-protocol reader IC
- 47x34 mm 2 turns double layer antenna on PCB and associated tuning circuit
- STM32F1 micro-controller
- USB & JTAG connectors



X-NUCLEO-NFC03A1

CR95HF Nucleo shield

- **CR95HF** NFC multi-protocol reader IC
- 47x34mm 4 turns antenna on PCB
- SPI (Slave interface) or UART
- Up to 528-byte command/reception buffer
- Optimized power management
- Powered through Arduino™ UNO R3 connector

CR95HF demo board is part of M24LR-DISCOVERY

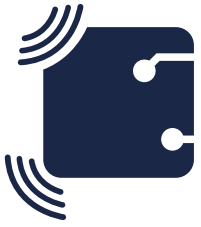

ST25R3911B evaluation boards

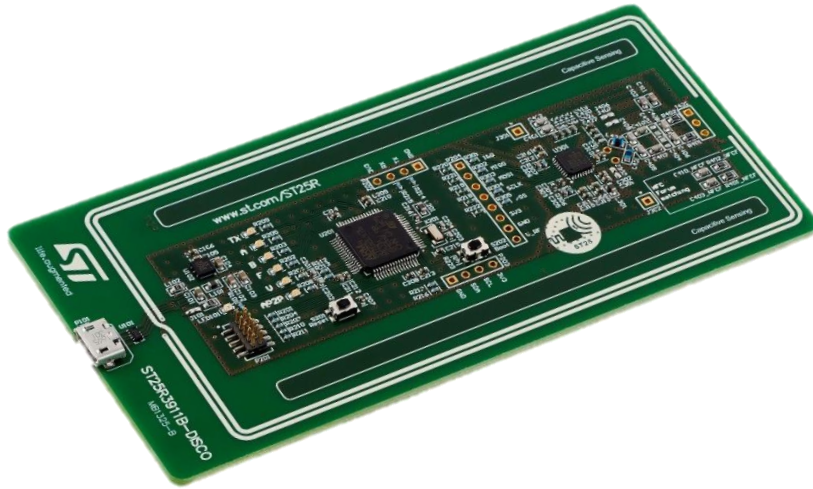

ST25R3911B-DISCO



X-NUCLEO-NFC05A1

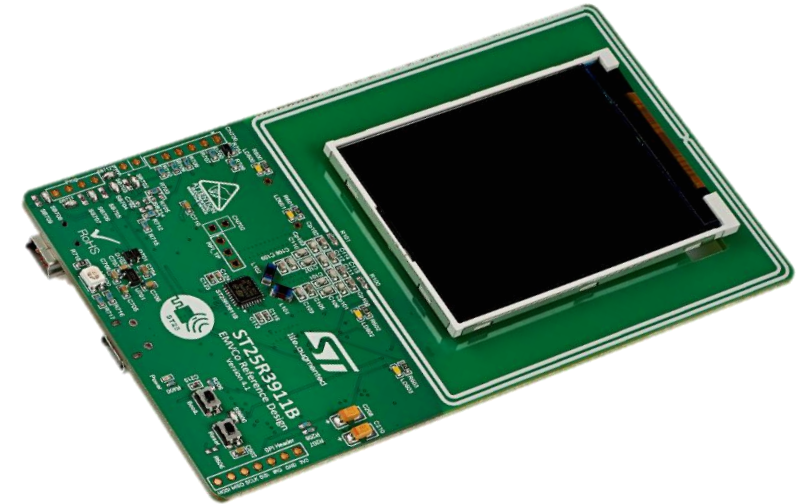

ST25R3911B-EMVCO

ST25R3911B discovery kit

- **ST25R3911B** HF reader / NFC initiator IC
- 105x52mm 2 turns antenna and associated VHBR tuning circuit
- STM32L476RET6 32-bit MCU
- Micro-USB connector
- Additional UART / I²C Host interfaces, as well as NFC SPI and JTAG/SWD points

ST25R3911B Nucleo shield

- **ST25R3911B** HF reader / NFC initiator IC
- 47x34mm 4 turns antenna
- Compatible with STM32 Nucleo boards
- Equipped with Arduino™ UNO R3 connector

ST25R3911B EMVCO kit

- **ST25R3911B** HF reader / NFC initiator IC
- 65x74mm 2 turns antenna etched on PCB
- STM32L476 32-bit MCU
- Micro-USB connector
- Comprehensive Device Test Environment (DTE) for EMVCo Level 1 FW control
- S-Touch controller



ST25R3916B evaluation boards

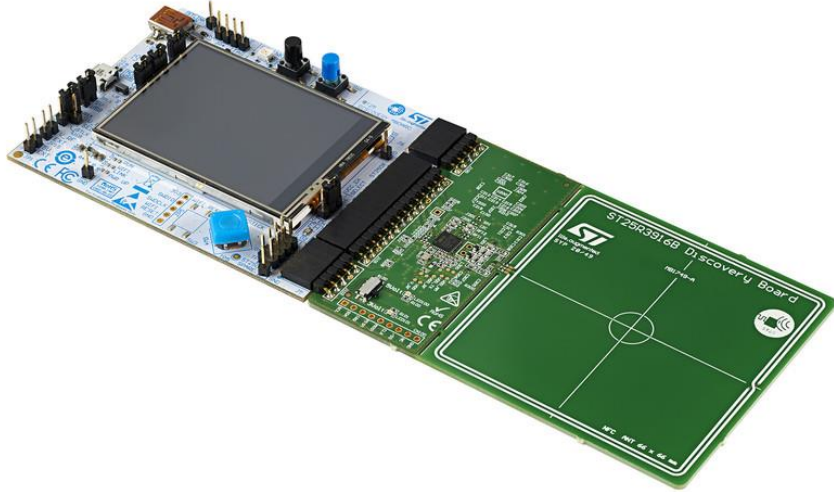

STEVAl-25R3916B



X-NUCLEO-NFC08A1



ST25R3916B-EMVCO

ST25R3916B discovery kit

- **ST25R3916B** High perf NFC universal device and EMVCo® reader
- 66 x 66 mm 2 turns antenna etched on PCB
- STM32L476 ULP 32-bit MCU
- Micro-USB connector
- Additional UART / I²C host interfaces, as well as NFC SPI and JTAG/SWD points

ST25R3916B Nucleo shield

- **ST25R3916B** High perf NFC universal device and EMVCo® reader
- 47 x 34mm 4 turns antenna etched on PCB
- Compatible with STM32 Nucleo boards
- Equipped with Arduino® UNO R3 connector

ST25R3916B EMVCo® kit

- **ST25R3916B** High perf NFC universal device and EMVCo® reader
- 51 x 27mm 3 turns antenna etched on PCB
- STM32L476 ULP 32-bit MCU
- Micro-USB connector
- Comprehensive device test environment (DTE) for EMVCo® Level 1 FW control

Discovery kit and Nucleo shield are also valid for ST25R3917B and ST25R3920B.

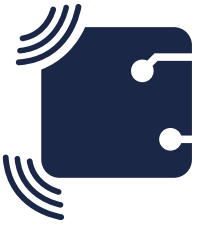

ST25RU3993-HPEV evaluation board



ST25RU3993-HPEV

ST25RU3993-HPEV kit

- **ST25RU3993** UHF reader IC
- **High Power E**Valuation board
- STM32L476 MCU based
- External PA with 30 dBm output power
- Internal PA with 18 dBm output power
- Max. sensitivity: -80 dBm
- Kit content:
 - 1 x ETSI far field antenna
 - 1 x FCC far field antenna
 - 1 x Near field antenna
 - 2 x UHF RFID tag

ST25 SW ecosystem



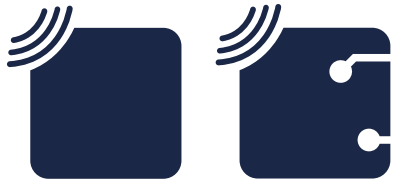

ST25T & ST25D software overview

SW supporting ST25 NFC Tags and Dynamic NFC Tags

ST25 Mobile apps



 ST25 NFC Tap app for Android

 ST25 NFC Tap app for iOS

- Based on ST25 SDK



ST25 PC Software

- ST25 PC Software for NFC Readers
- Support of Tags and Dynamic Tags functionalities including TruST25 services

- Based on ST25 SDK



ST25 Webservice

- Demo for ST25 NFC Tags



Firmware for MCU

- Firmware for STM32 microcontrollers
- SW driver for Dynamic NFC Tags IC
- Including demos



ST25 Android mobile apps

ST25 NFC Tap for Android

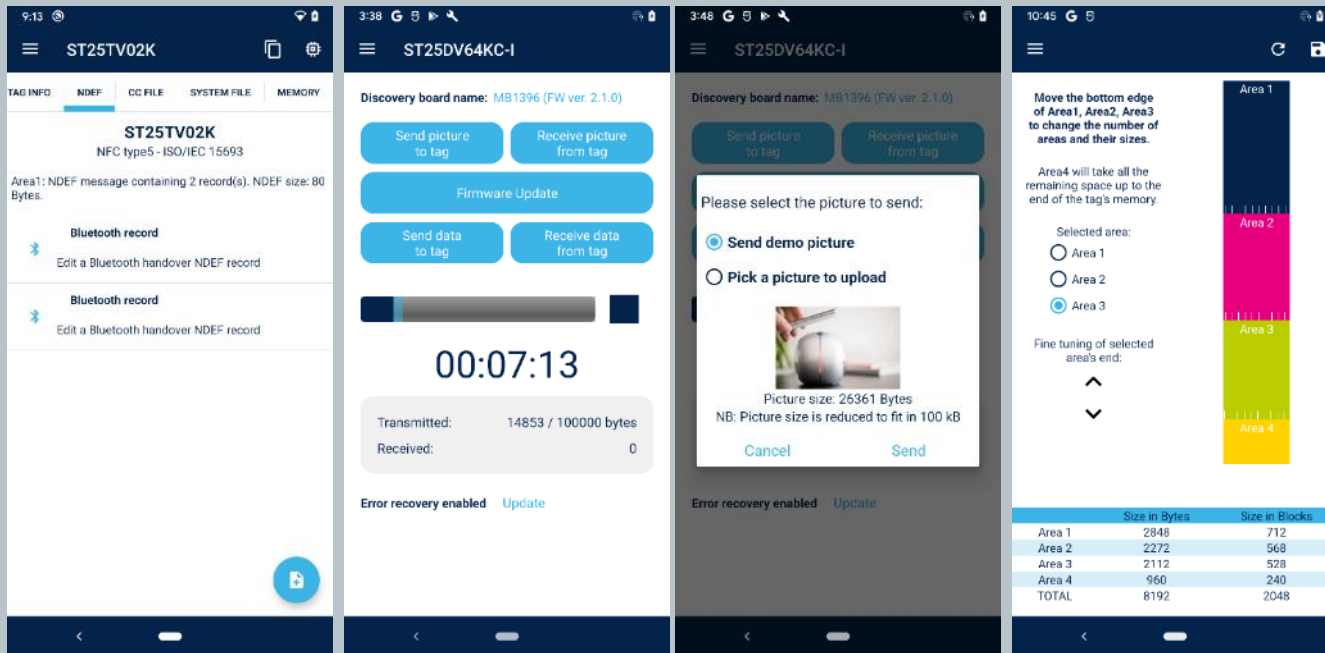

- Read/Write NDEF and User memory of ST25 Tags
- Support of specific functionalities of ST25 Tags (Tamper detect, Augmented NDEF, PWM output, TruST25 digital signature...)
- Includes demos for Fast Transfer Mode (FTM), PWM and Wifi or Bluetooth pairing
- Automatic launch of Android app
- ST25 NFC tap apk file ([STSW-ST25001](#))
- ST25 NFC tap open-source code ([STSW-ST25002](#))



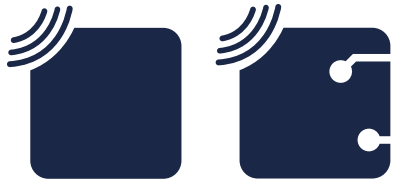

ST25 iOS mobile apps

ST25 NFC Tap for iOS

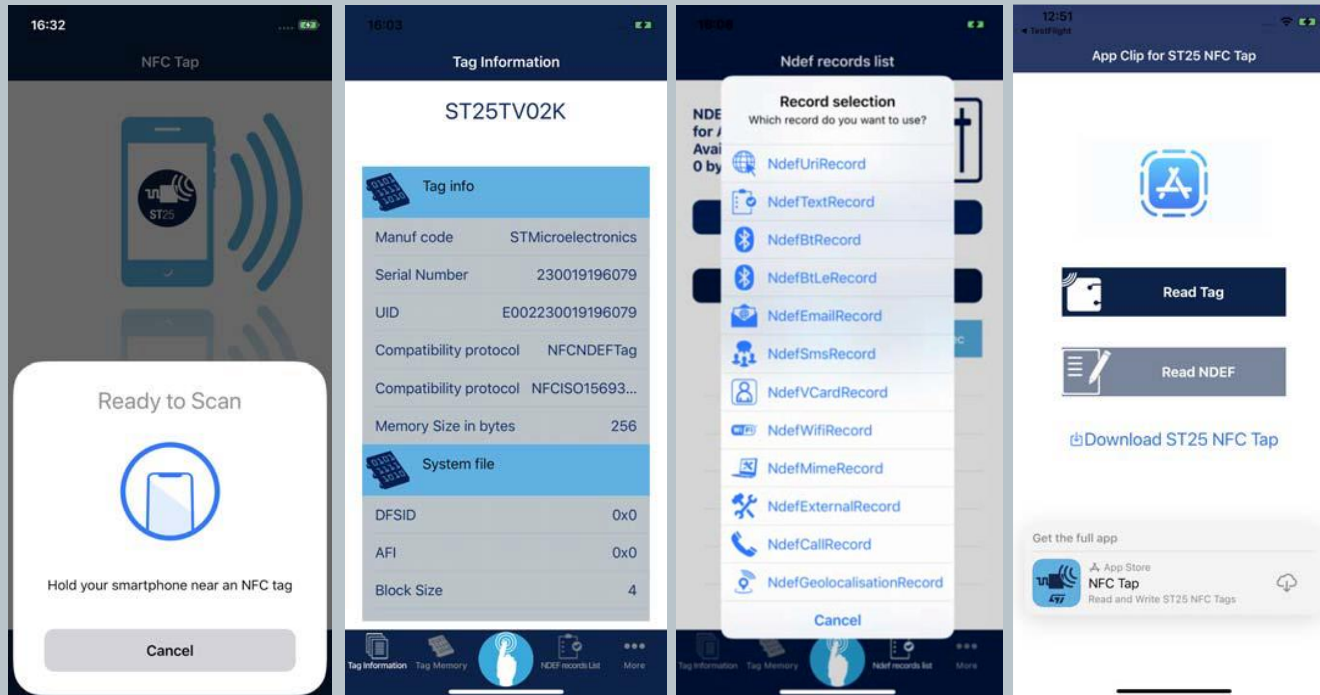

- App Clip for User Experience
- Read/Write NDEF and User memory of ST25 Tags
- Support of specific functionalities of ST25 Tags (PWM output, TruST25 digital signature...)
- Includes demos for Fast Transfer Mode (FTM), Bluetooth pairing and PWM
- Support of NFC background tag reading
- Automatic launch of iOS app
- ST25 NFC Tap open-source code ([STSW-ST25IOS002](#))
- Support iOS14 & iOS15 beta



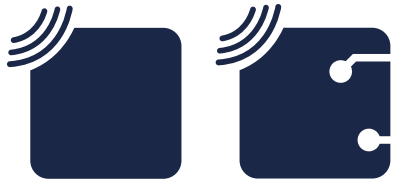

ST25 PC software

ST25 PC software for ISO15693, ISO14443-A/B & NFC readers



The screenshot shows the ST25 PC software interface. On the left is a menu with options like 'NDEF Editor', 'User Memory', 'Password Manager', etc. The middle panel has sections for 'Tag Operation', 'Addressing mode', 'Unit selection', 'Read EEPROM', and 'Write to EEPROM'. The right panel displays a table of memory areas.

Area	Block	Data	ASCII
01	00	E2 40 00 F2	â @ . ð
01	01	00 00 04 E2	. . . â
01	02	03 00 D1 03	. . . ñ .
01	03	0B E0 74 65	. ä t e
01	04	78 74 2F 78	x t / x
01	05	2D 76 43 61	- v C a
01	06	72 64 42 45	r d B E
01	07	47 49 4E 3A	G I N :
02	08	56 43 41 52	V C A R
02	09	44 0D 0A 56	D . . V
02	0A	45 52 53 49	E R S I
02	0B	4F 4E 3A 32	O N : 2
02	0C	2E 31 0D 0A	. 1 . .
02	0D	4E 3A 59 6F	N : Y o
02	0E	75 3B 43 61	u ; C a
02	0F	6E 49 48 65	n I H e
03	10	6C 70 3B 3B	l p ; ;
03	11	3B 0D 0A 46	; . . F
03	12	4E 3A 43 61	N : C a
03	13	6E 49 48 65	n I H e
03	14	6C 70 20 59	l p Y
03	15	6F 75 0D 0A	o u . .
03	16	54 45 4C 3B	T E L ;
03	17	43 45 4C 4C	C E L L
04	18	3A 2B 33 33	: + 3 3
04	19	36 31 32 33	6 1 2 3
04	1A	34 35 36 37	4 5 6 7

- Feature set support of ST25 NFC Tags and Dynamic Tags
- PC SW for Windows
- Read/Write NDEF records on multiple tags
- Support of TruST25 digital signature feature
- Compatible with ST25R3916B, ST25R3911B & CR95HF demo boards and industrial readers (FEIG)
- Fast Transfer Mode (FTM) demo with ST25DV-Discovery board
- Free to use demo PC SW ([STSW-ST25PC001](#)) and open-source code ([STSW-ST25PC002](#))





ST25 SDK



ST25 Software Development Kit

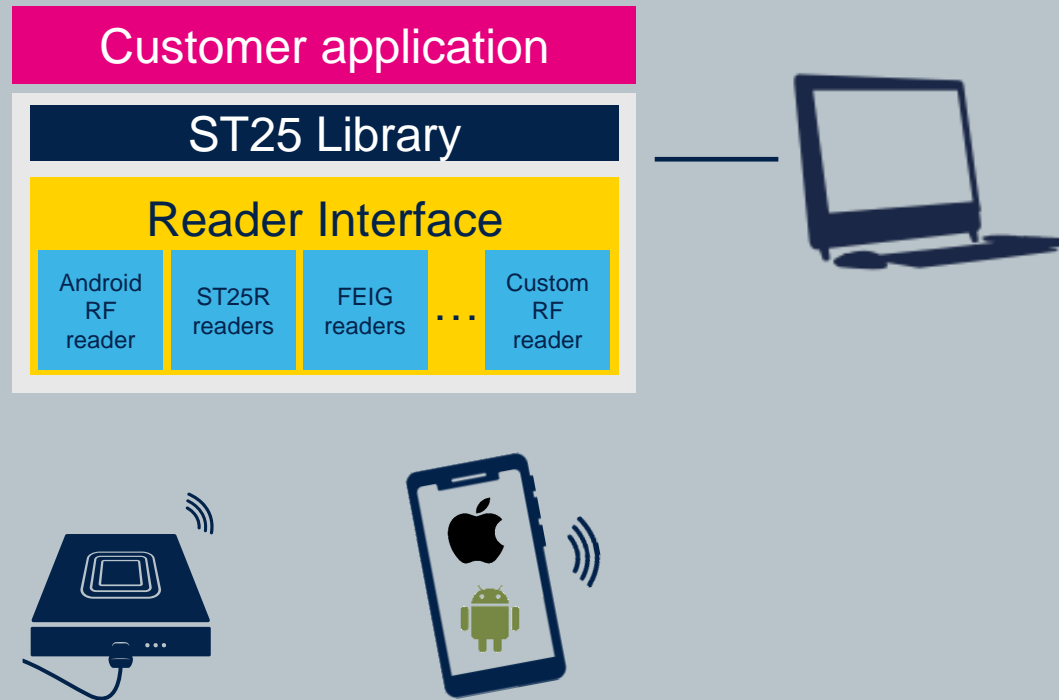

- SW library for Java™ applications development
- Multiplatform (Windows, Linux...)
- RF Library used in Android & iOS *ST25 NFC Tap* apps as well as PC software
- Includes examples and readers reference implementations
- API documentation
- ST25 SDK SW package ([STSW-ST25SDK001](#))





ST25D Firmware for MCU

Firmware for ST25D Discovery, Nucleo & ANT7 boards

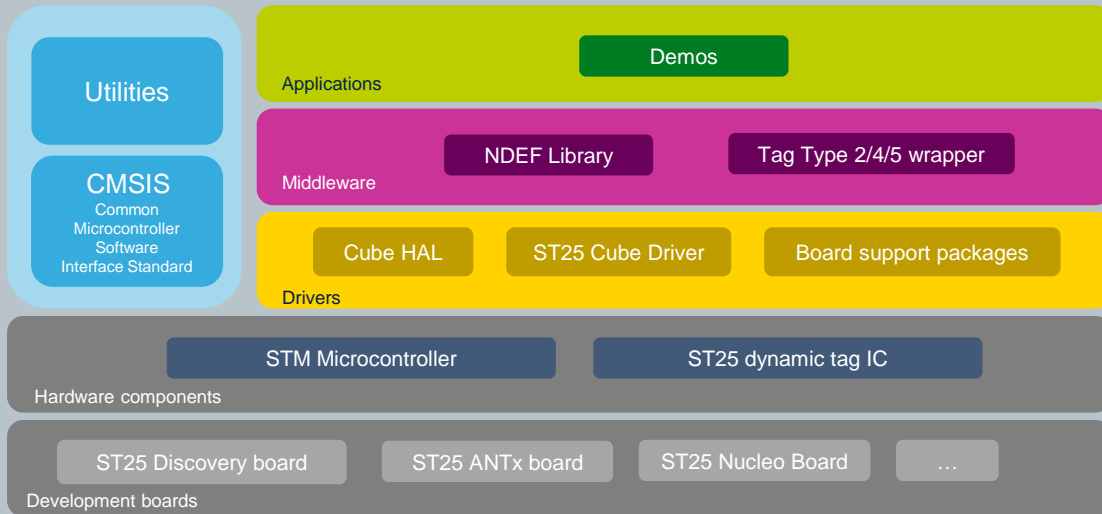
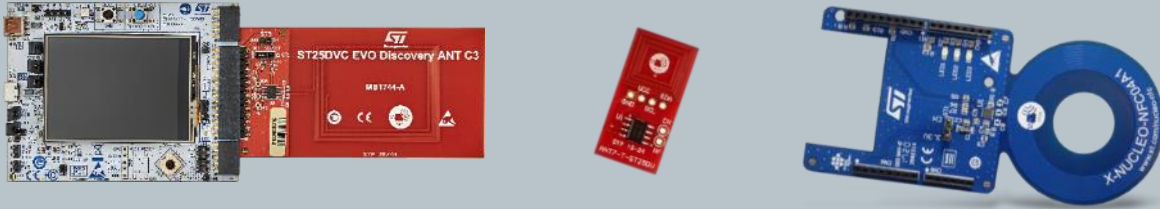

- Complete set of source files to compile firmware for development boards (Discovery, Nucleo...)
- Includes Fast Transfer Mode (FTM) demo
- Read/store NDEF messages
- Supports specific features of ST25 Dynamic Tags IC (Energy Harvesting, interrupts, states...)
- Compatible with any NFC Readers
- Compatible with any NFC smartphones, using the *ST25 NFC Tap* app
- ST25DV-I2C-EVO Discovery kit FW ([STSW-ST25DV002](#)) and Nucleo board FW ([X-CUBE-NFC7](#))





ST25 Webserver

ST25 Webserver demo for ST25 NFC Tags

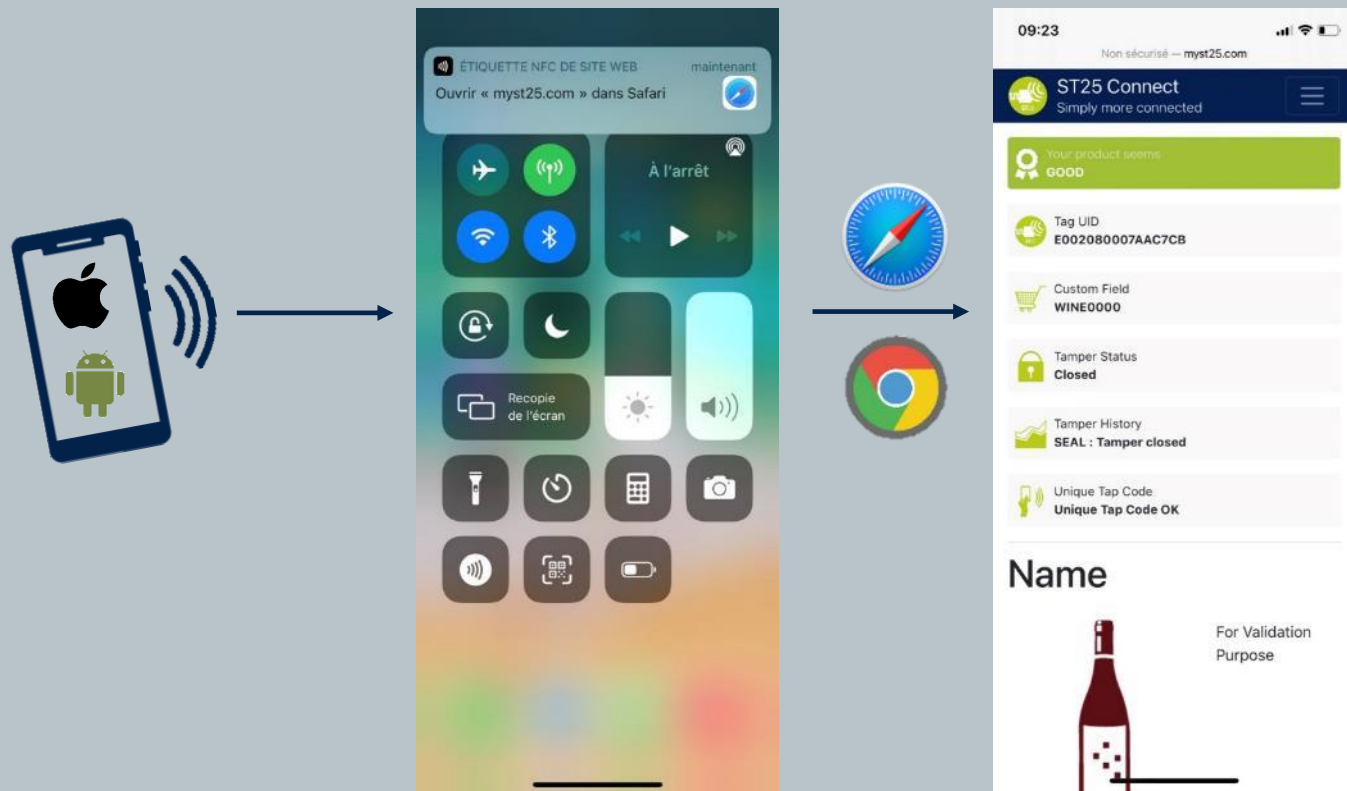

- Open-source webserver: www.myst25.com
- Compatible with ST25TV and ST25TN product series
- Augmented NDEF experience
- Native and automatic access to NDEF records
- Shared with customers on specific request and through MFT platform (SLA0085 process)
- Developed in HTML5 and PHP7.0 – Uses MySQL database
- Source code can be shared on request



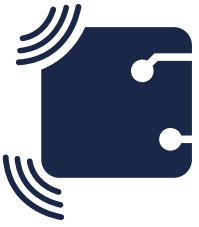

ST25R software overview

Software development tools for ST25R HF Reader IC

Graphical User Interface (GUI)



USB

GUI for ST25R
PC software for Windows

On request:
GUI for ST25R EMVCo
PC software for Windows

Firmware

DISCO board

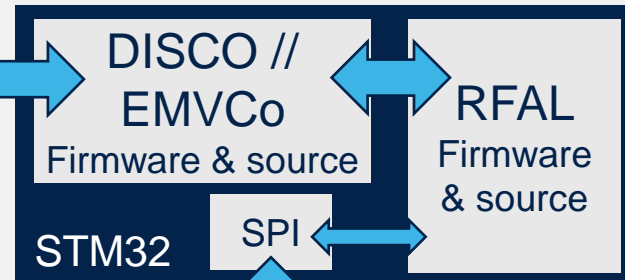

ST25R

NUCLEO board

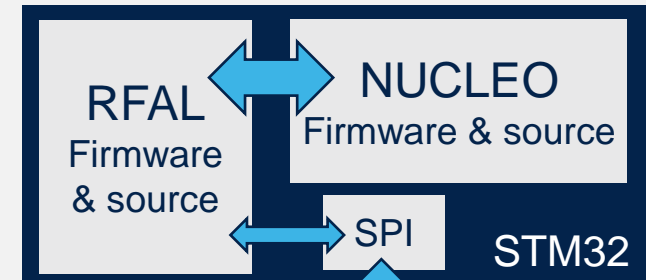

ST25R

LOG file



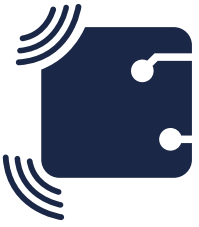

ST25R RFAL SW suite



ST NFC Reader “RFAL” software suite

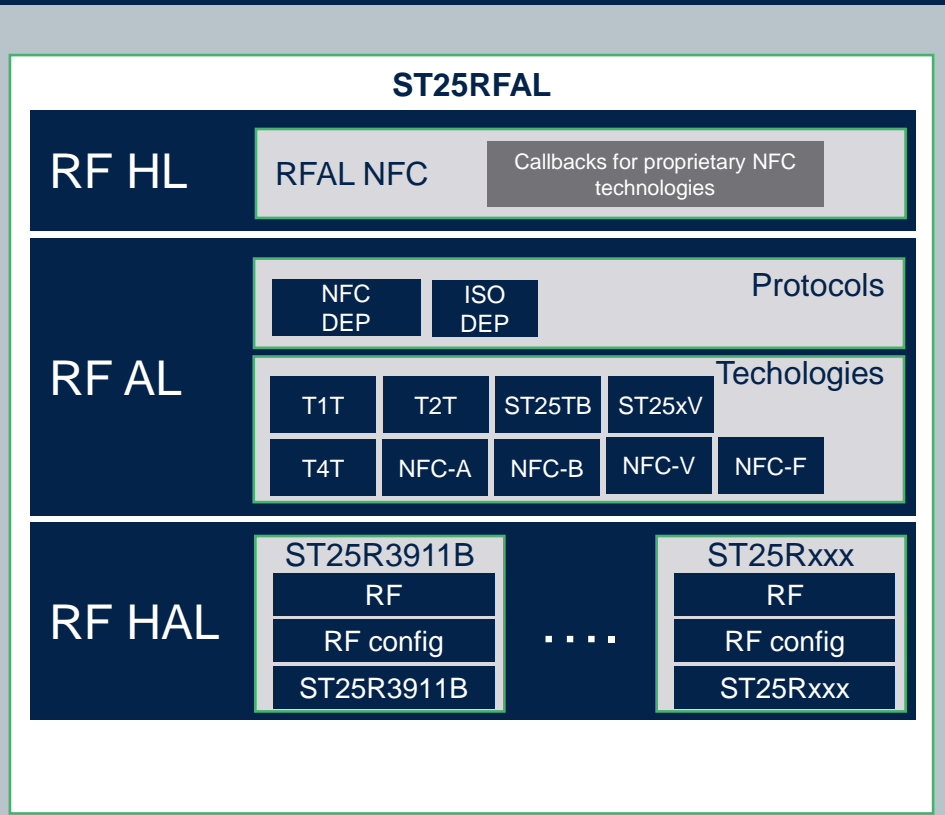

- Comprehensive device driver and middleware to build NFC enabled applications for reader devices based on ST25R NFC Readers
- Written in pure ANSI C
- Straightforward portability across different platforms (MCU/RTOS/OS) with non-blocking API
- Compliant with main HF/NFC standards (NFC Forum, ISO)
- Source code example implementations available: embedded (STM32, STM8 device, SPC5 on request) and Linux® (Raspberry Pi)
- Easy callback function for proprietary NFC technologies on application layer like Apple™ Mfi (delivered under Mfi conditions) and other technologies
- ST25R3916/16B RFAL SW ([STSW-ST25RFAL002](#)) and ST25R3911B RFAL SW ([STSW-ST25RFAL01](#))



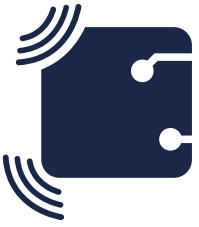

ST25R PC GUI software

ST NFC Reader “Discovery” software suite

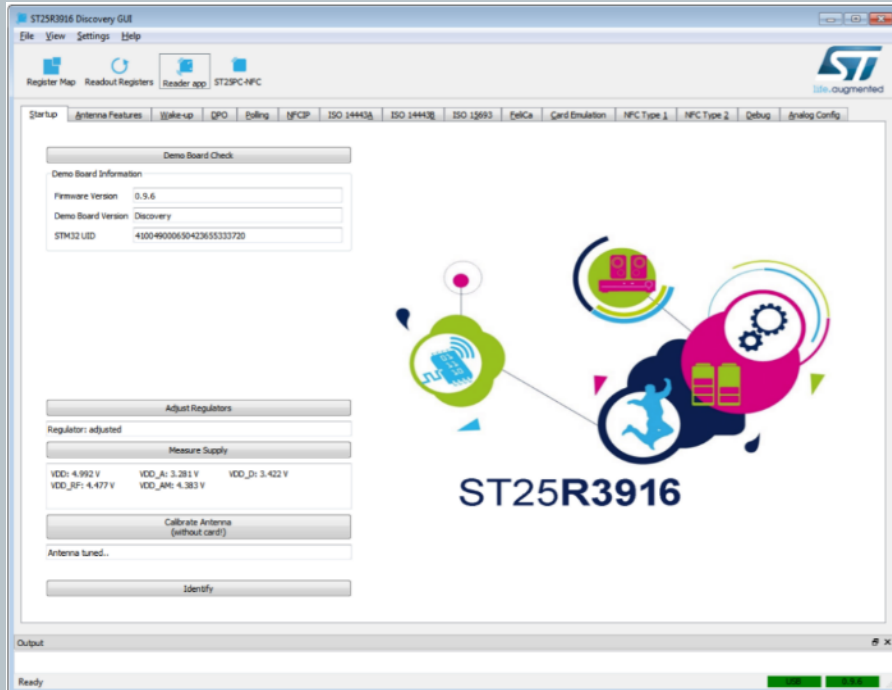

- Supports several RF protocols (ISO14443-A / NFC-A, ISO14443-B / NFC-B, FeliCa™ / NFC-F and ISO15693 / NFC-V)
- Active P2P (peer to peer) according to ISO18092, including SNEP
- Card emulation in NFC-A (106kbps) and NFC-F (212 and 424kbps)
- Wakeup feature, analog configuration and register access of ST25R3916B
- Support of Automatic Antenna Tuning (AAT) & Dynamic Power Output (DPO)
- Access to all ST25 Tag features thanks to ST25PC NFC SW ([STSW-ST25PC001](#))
- ST25R3916 PC GUI SW ([STSW-ST25R010](#)) and ST25R3911B PC GUI SW ([STSW-ST25R001](#))



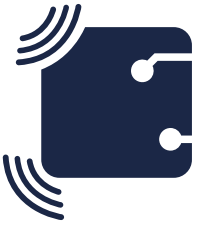

ST25R Firmware for MCU



Firmware for ST25R Discovery, Nucleo & EMVCo boards

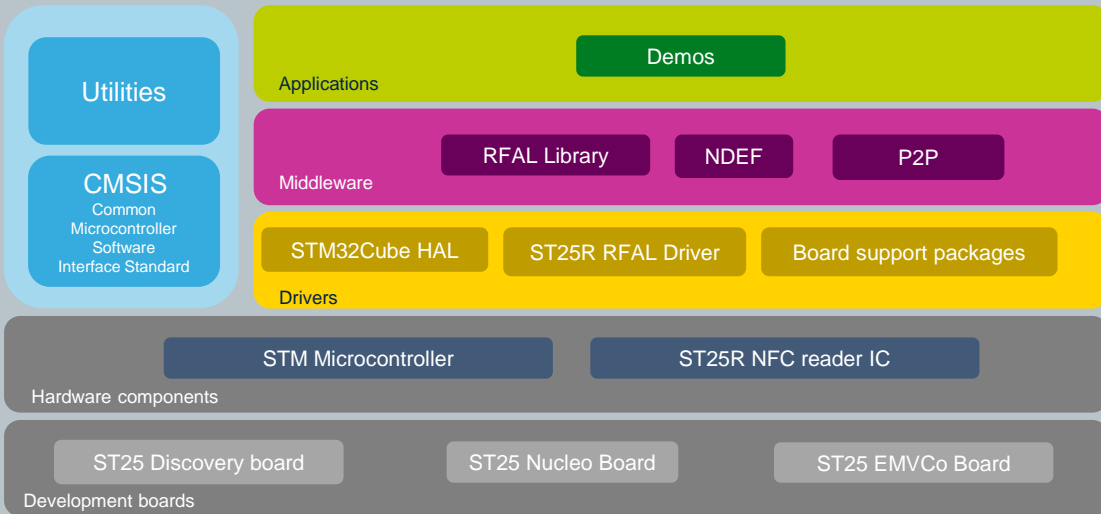

Complete set of source files to compile firmware for development boards (Discovery, Nucleo...)

- Reader / Writer demonstration
 - Tag inventory, read and write (all NFC standard protocols supported)
 - Dynamic power output
 - NFC Forum NDEF messages
- Card emulation demonstration
 - NFC Type 4A Tag emulation (all tag types supported in USB mode)
 - NFC Forum NDEF messages
 - Possibility to be written by a reader or by a smartphone
- Peer to peer (P2P) demonstration
- EMVCo Layer 1 support FW, on request
- ST25R3916 Disco kit FW ([STSW-ST25R011](#)), ST25R3916 Nucleo board FW ([X-CUBE-NFC6](#)) and ST25R3911B Disco kit FW ([STSW-ST25R002](#))



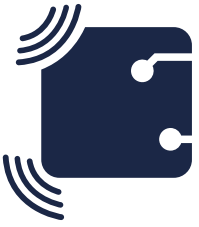

ST25R antenna matching software kit

ST NFC Reader “Antenna Matching” software kit

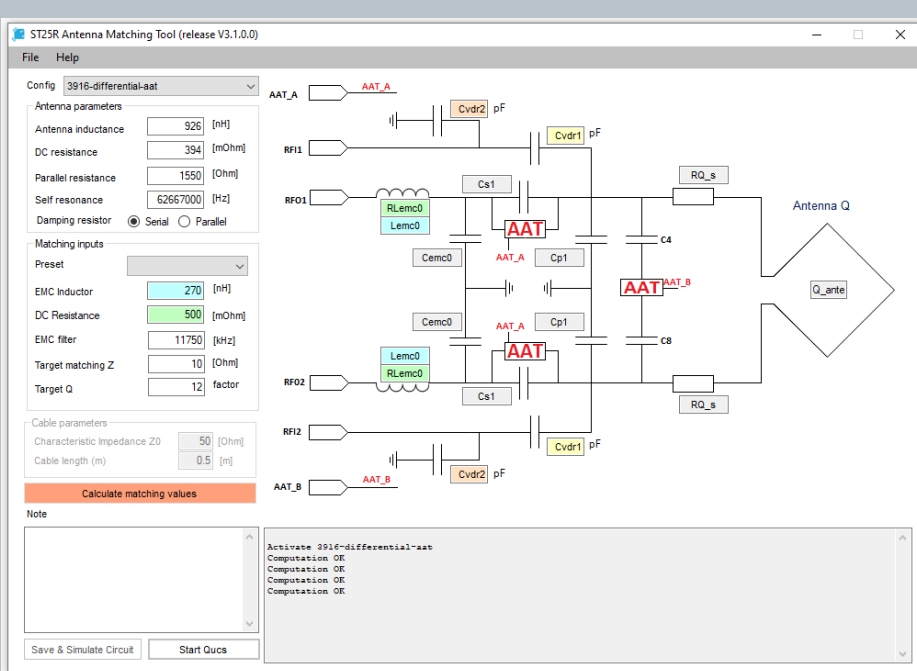

- Comprehensive antenna matching tool with GUI to find the right external component values for a chosen configuration
- Available for the entire ST25R HF Reader product line
- Allows configuration with or without AAT functionality
- Integrates circuit simulator (QUCS), automatic component value selection and generates the Smith Chart
- Standalone version for Windows PC and online tool available
- Antenna Matching tool for ST25R NFC/HF Reader ([STSW-ST25R004](#))



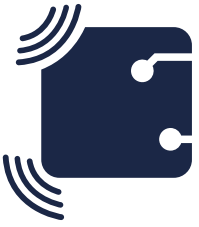

ST25R Linux software kit

ST NFC Reader “Linux” software kit

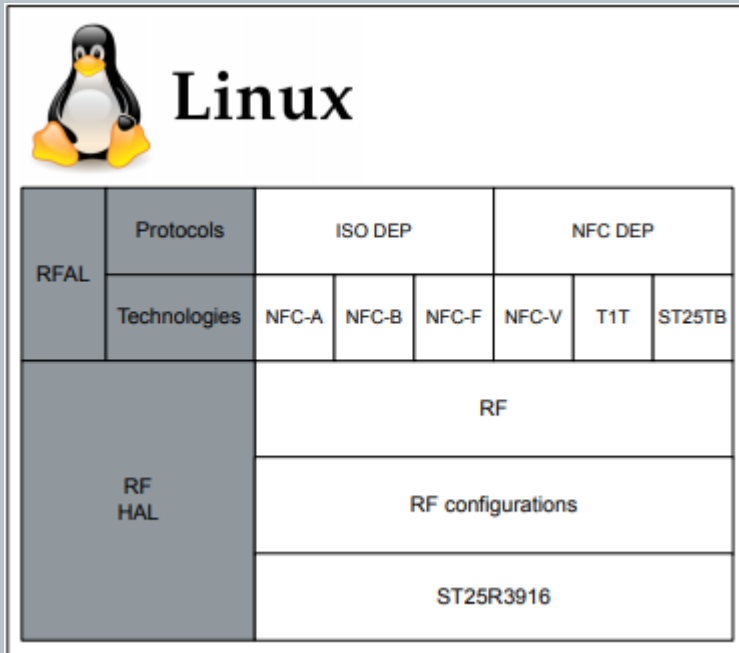

- Provides a pure user space port of the RFAL onto Raspberry Pi 3 and 4
- Support ST25R HF Readers
- Sample applications demonstrating Poller (R/W-mode) and Listener (Card Emulation)
- Linux host communication through SPI
- Free, user-friendly license terms
- Linux for ST25R3916 Raspberry Pi using X-NUCLEO-NFC06A1 ([STSW-ST25R013](#)) and Linux for ST25R3911B Raspberry Pi using X-NUCLEO-NFC05A1 ([STSW-ST25R009](#))



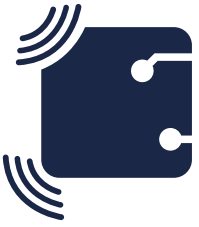

ST25R EMVCo software kit

ST NFC Reader “EMVCo” software Kit

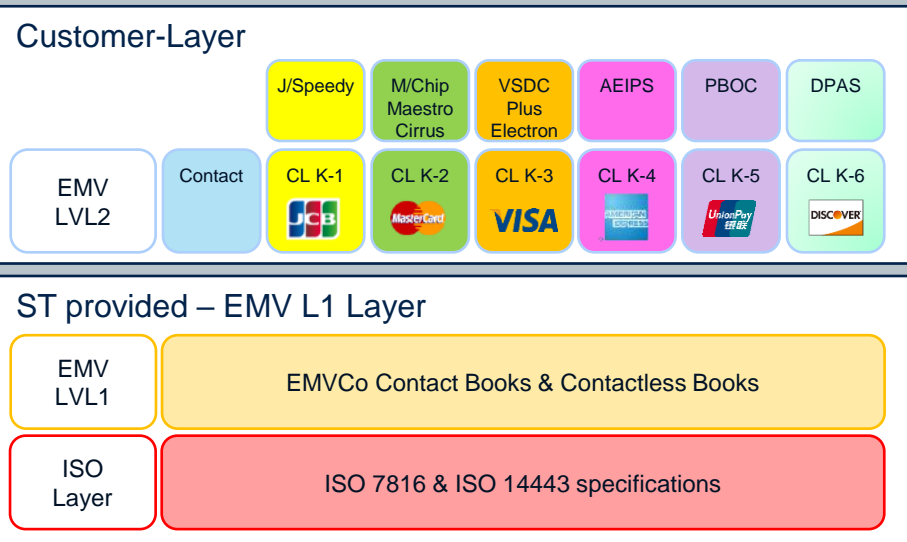

- ST provides EMVL1 firmware stack for contact-less products, as is
- Stack accessible under NDA for usage with ST25R series and available as source code
- Firmware accompanied by a GUI which allows easy configuration the device as well as active waveshaping and dynamic power output
- Written in pure ANSI C based on RFAL
- EMV L1 layer pre-validated (kept up to date)
- Portable on various architectures thanks to the abstraction layers which are integrated in the delivery
- Stack available with our POS demo kits on request



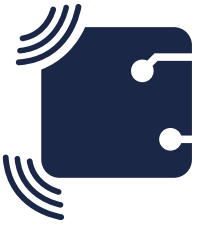

ST25R embedded NFC library software kit

ST NFC Reader “NFC Lib” software kit

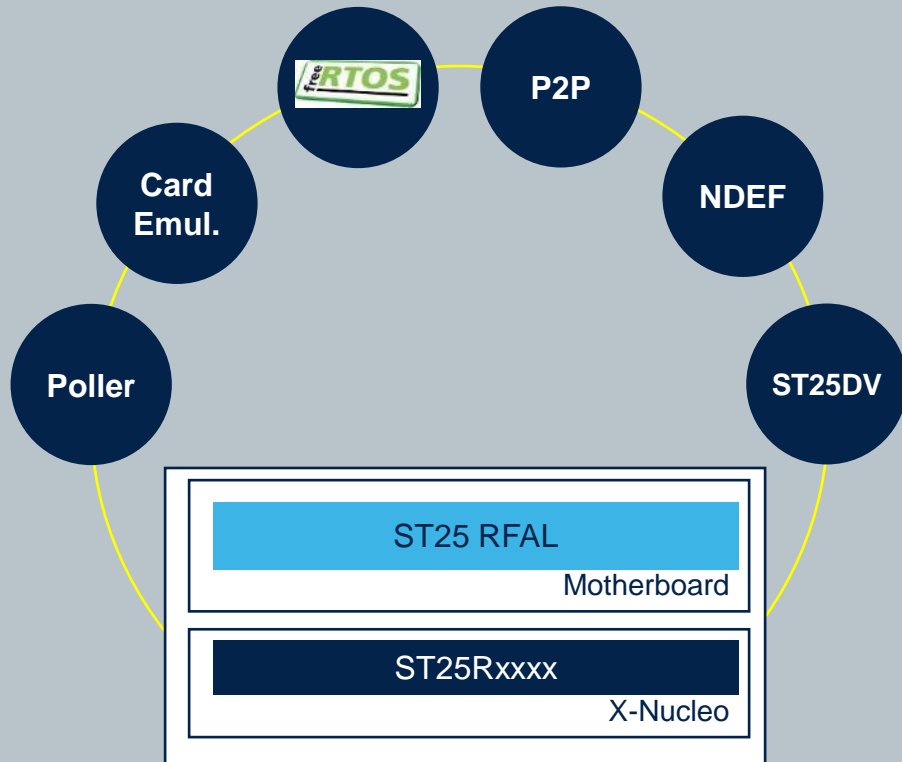

- Collection of middleware to build advanced NFC enabled applications such as
 - NFC poller
 - NDEF reader / writer
 - FreeRTOS poller
 - Proprietary active peer-to-peer & Card emulation
- Support for ST25 Tag and Dynamic Tag features
- ST25 Fast Transfer Mode (for ST25 Readers and Dynamic Tags)
- Easy portability across different platforms (MCUs / RTOSs / OSs)
- Available for all ST25R HF Readers, on request (free and user-friendly license terms)



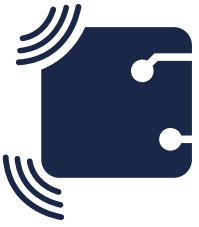

ST25RU3993 UHF software overview

Software development tools for ST25R UHF Reader IC



Graphical User Interface (GUI)

STSW-ST25RU001



GUI for ST25RU3993
PC software for Windows

Software Development Kit (SDK)

STSW-ST25RU-SDK

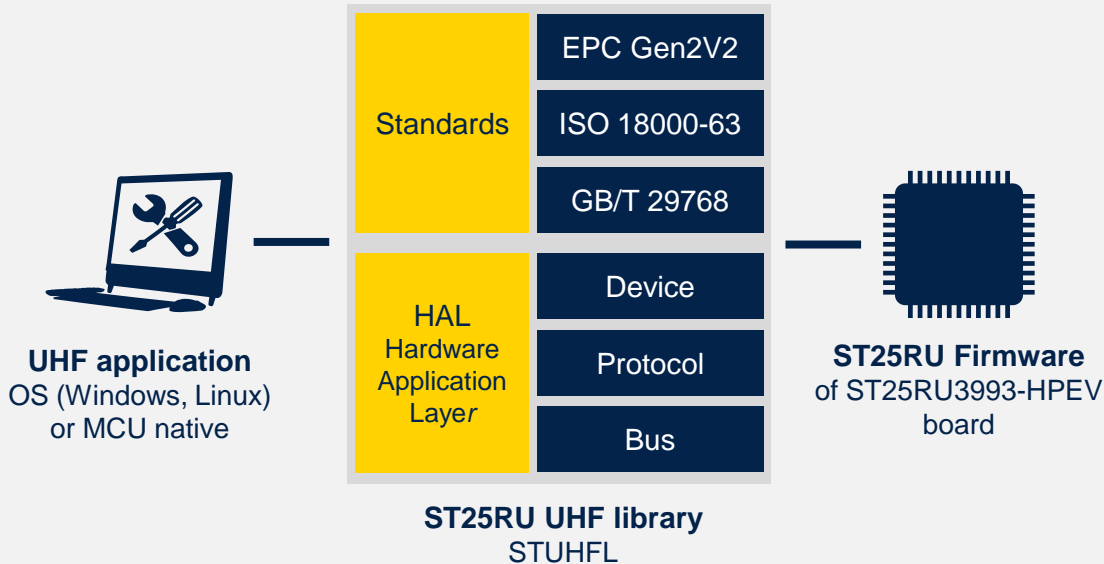

Open source, free to use software resources on application, middleware and firmware level.

- Software Development Kit (SDK)
 - UHF Application
 - ST25RU UHF Library (STUHFL)
 - Board Firmware (ST25RU3993-HPEV)
- ST25RU3993 Graphical User Interface (GUI)
 - PC software with implemented example use cases and direct register access to ST25RU3993 Reader IC



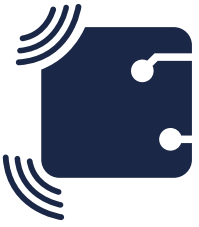

ST25RU3993 GUI

ST25RU3993 Graphical User Interface

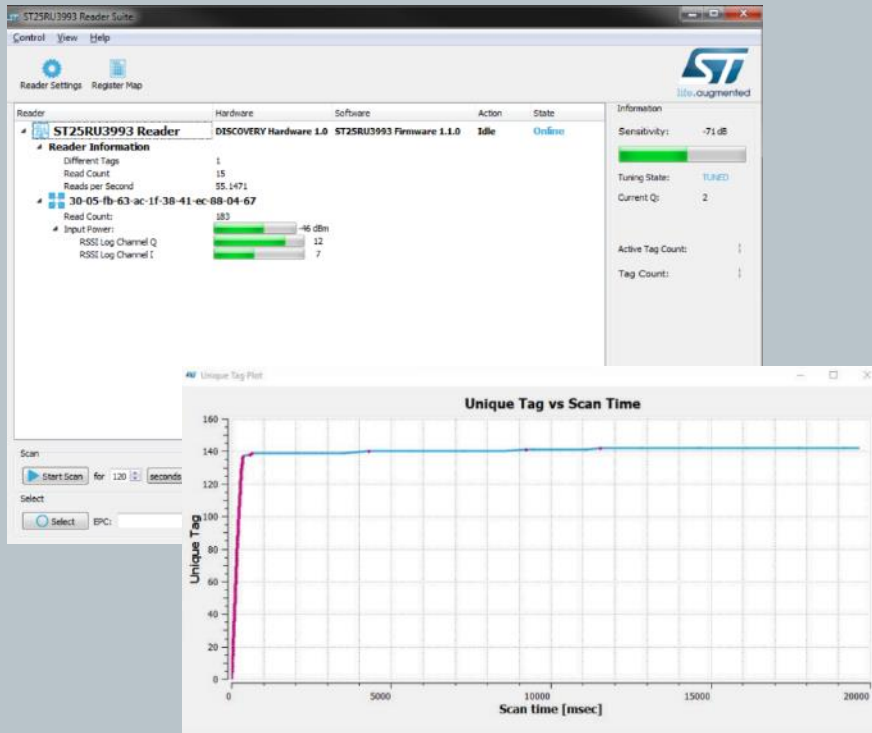

- PC software for ST25RU3993-HPEV board allowing full control and low level access to ST25RU3993 RAIN® Reader device for product evaluation & test
- The software supports following feature
 - Wide range of example use cases and features
 - Export of tag data and time stamps
 - Inventory visualization and performance chart
 - Direct access to ST25RU3993 registers
 - Multi protocol support (ISO 18000-63, EPC Class 1 Gen2, GB/T 29763)
 - Inventory with auto acknowledge for MCU relief
 - RSSI display & mode and frequency profile selection
 - Carrier cancellation and Tag access with crypto support
- ST25RU3993 PC GUI SW ([STSW-ST25RU001](#))



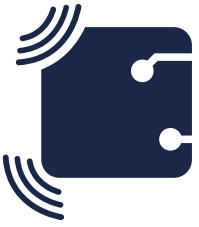

ST25RU3993 UHF application



UHF application example (ST25RU3993 SDK)

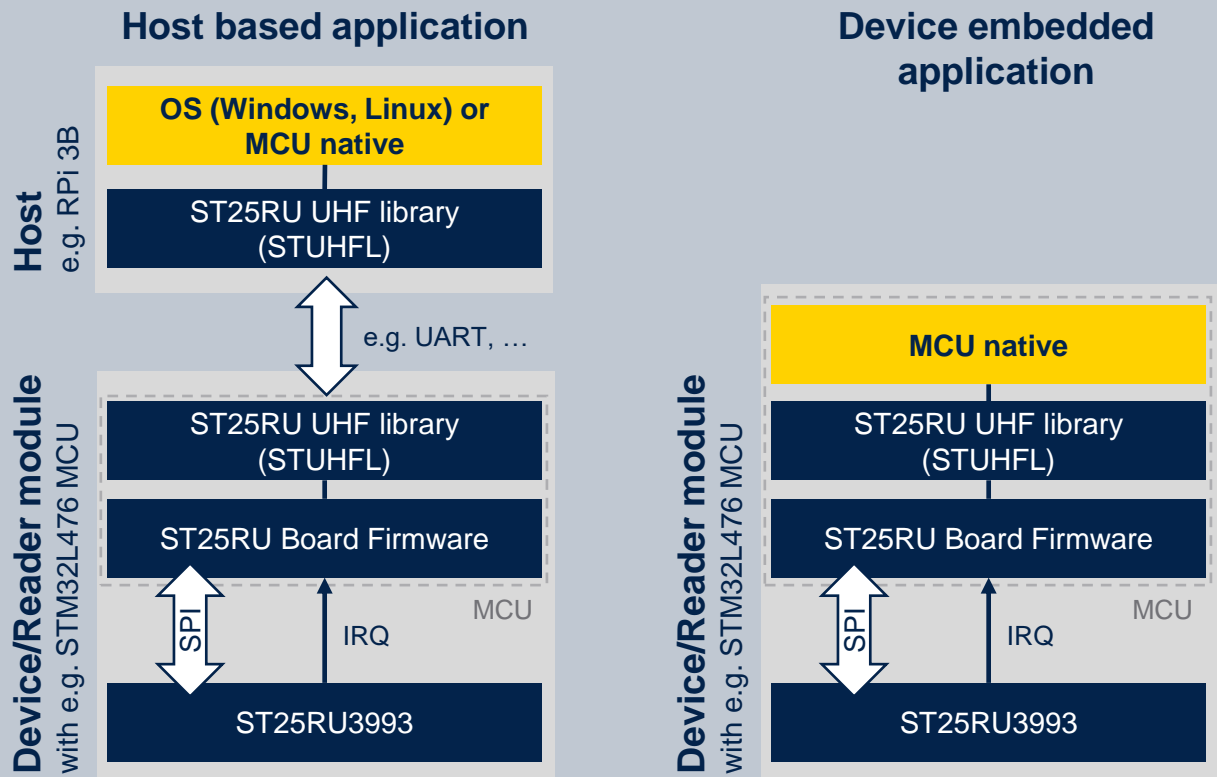

- UHF application examples for quick implementation of individual GUI or other interfaces
- Examples allow development own customized applications via copy & paste
- Available for operating systems
 - Windows
 - Linux
- Available for MCU native (FW)
 - Can be run directly on MCU (STM32L4)
- Included inside ST25RU3993 SDK ([STSW-ST25RU-SDK](#))



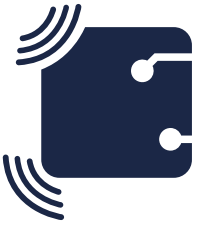

ST25RU3993 STUHFL

ST25RU3993 UHF Library

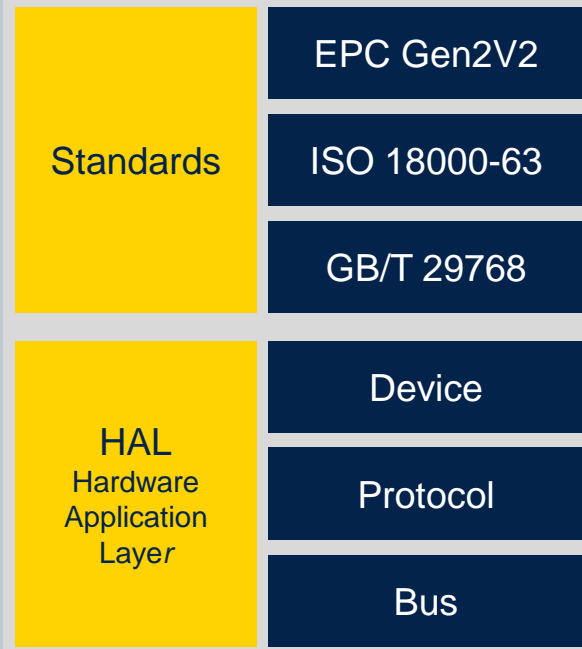

Comprehensive middleware to build RAIN® RFID enabled applications for reader devices based on ST25RU3993

- Written in pure ANSI C
- POSIX compliant
- Straightforward portability across different platforms (MCU/RTOS/OS)
- SW Wrappers for state-of-the-art programming languages: Java / C# / Python
- Compliant with main UHF standards: EPC Gen2v2, ISO18000-63 & GB/T29768
- Source code examples available
 - Windows®
 - Linux® (Raspberry Pi 3B & 4B)
 - Embedded (STM32L4 device)
- Included inside ST25RU3993 SDK ([STSW-ST25RU-SDK](#))

ST solutions



• ST25 UHF Reader

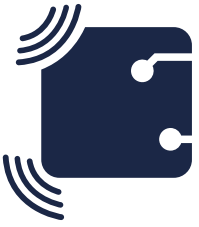

ST25RU3993 Firmware for MCU



Firmware for ST25RU3993 Discovery board

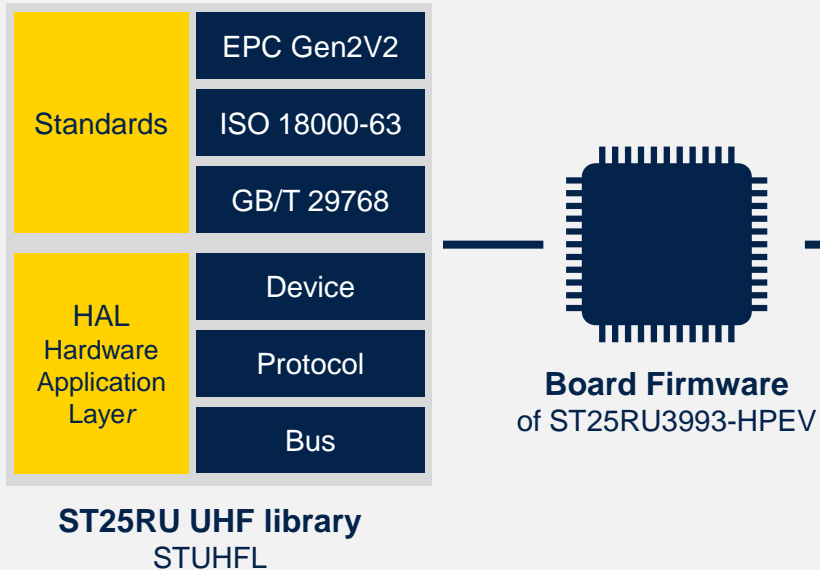

Board Hardware with ST25RU3993



ST25RU3993

- MCU with open-source firmware managing ST25RU3993 driver for various UHF RFID protocols and implementing a software interface to the ST UHF library (STUHFL)
- Reference based on STM32 MCU
- Included inside ST25RU3993 SDK ([STSW-ST25RU-SDK](#))





life.augmented

Solutions for NFC / RFID Tags & Readers



ST25 SIMPLY MORE CONNECTED



Our technology starts with You



Find out more at www.st.com/st25

© STMicroelectronics - All rights reserved.

ST logo is a trademark or a registered trademark of STMicroelectronics International NV or its affiliates in the EU and/or other countries.

For additional information about ST trademarks, please refer to www.st.com/trademarks.

All other product or service names are the property of their respective owners.



life.augmented