

PART NO. TU78

TOLERANCES UNLESS SPECIFIED		
TWO PLACE DECIMALS +/- .015	THREE PLACE DECIMALS +/- .005	ANGLES +/- 1°

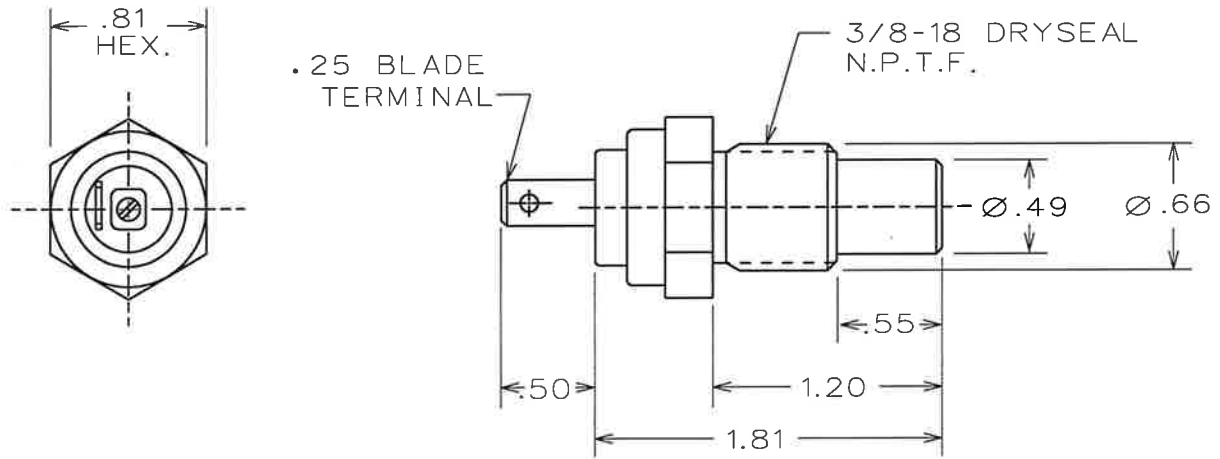

MAKES CONTACT BETWEEN TERMINAL AND HOUSING AT 240° F ±10° F.

NOTES:  
1. REFERENCE "ASME Y14.5M-1994".

REPLACES O.E. #25036317, D1850A, D1863B, D1892

					MATERIAL	SCALE FULL	
					FINISH	DATE 1-16-98 DWN. BY KLH	
						ENGINEER 1-16-98 TF	
						APPROVED 1-16-98 JSK	
						PURCH. <input type="checkbox"/> PROD. <input type="checkbox"/>	
RELEASED	21273	1-16-98	KLH				TITLE TEMPERATURE SWITCH
L	REVISION	CN	DATE	BY	CAD REF. TU78	MODEL	PART NO. TU78