

METAZA

MPX-90

USER'S MANUAL

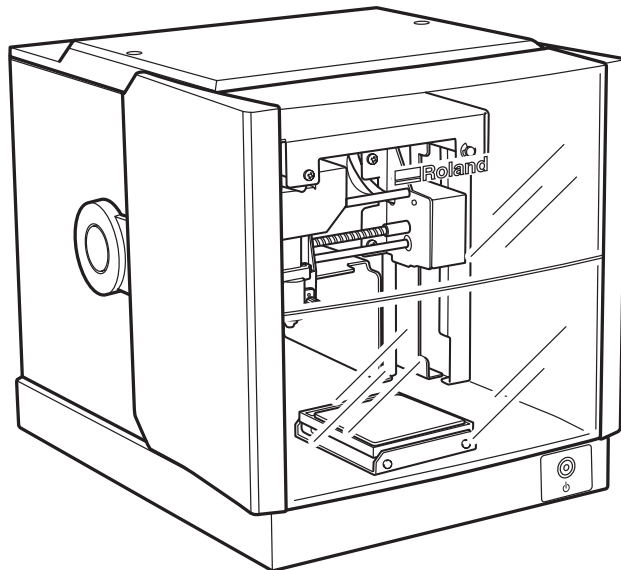

- To ensure safe usage and full performance of this product, please be sure to read through this manual completely.
- To ensure immediate access whenever needed, store this manual in a safe location.
- Unauthorized copying, quotation, or translation of this manual, in whole or in part, without the written approval of Roland DG Corp., is prohibited.
- The contents of this document and the specifications of this product are subject to change without notice.
- Roland DG Corp. assumes no responsibility for any loss or damage relating to this product, regardless of any defect in this product or this manual. Such loss or damage, whether direct or indirect, includes, but is not limited to, that arising from the specifications or performance of this product, that due to failure of the product to perform, and that arising from any article made using this product.

For the USA

FEDERAL COMMUNICATIONS COMMISSION RADIO FREQUENCY INTERFERENCE STATEMENT

NOTE:

This equipment has been tested and found to comply with the limits for a Class A digital device, pursuant to Part 15 of the FCC Rules.

These limits are designed to provide reasonable protection against harmful interference when the equipment is operated in a commercial environment.

This equipment generates, uses, and can radiate radio frequency energy and, if not installed and used in accordance with the instruction manual, may cause harmful interference to radio communications.

Operation of this equipment in a residential area is likely to cause harmful interference in which case the user will be required to correct the interference at his own expense.

Unauthorized changes or modification to this system can void the users authority to operate this equipment.

Use only I/O cables that have been designed and manufactured specifically for this device.

For Canada

NOTICE

This Class A digital apparatus meets all requirements of the Canadian Interference-Causing Equipment Regulations.

AVIS

Cet appareil numérique de la classe A respecte toutes les exigences du Règlement sur le matériel brouilleur du Canada.

For California

WARNING

This product contains chemicals known to cause cancer, birth defects and other reproductive harm.

For EU Countries

WARNING

This is a Class A product. In a domestic environment this product may cause radio interference in which case the user may be required to take adequate measures.

For EU Countries



Manufacturer:

ROLAND DG CORPORATION

1-6-4 Shinmiyakoda, Kita-ku, Hamamatsu-shi, Shizuoka-ken, 431-2103 JAPAN

The authorized representative in the EU:

Roland DG Corporation, German Office Halskestrasse 7, 47877 Willich, Germany

Roland DG Corp. has licensed the MMP technology from the TPL Group.

Contents

Contents	1
⚠ To Ensure Safe Use	4
Important Notes on Handling and Use	9
About Operation Manuals	10
Documentation Included with the Machine	10
How to Display Help for Software	10
How to Display Help for METAZA Driver	11
Chapter 1 Getting Started	13
1-1 About the Machine	14
Features.....	14
1-2 Names and Functions	15
This Machine	15
1-3 Checking the Included Items.....	17
Chapter 2 Installation and Setup	19
2-1 Installation.....	20
Installation Environment	20
Removing and storing the retainers.....	21
2-2 Cable Connections.....	23
Connecting the machine to a power supply.....	23
2-3 Installing the Software.....	24
System Requirements.....	24
The Software You Can Install and Set Up.....	24
Installing METAZA Driver.....	25
Installing the Software	26
2-4 METAZAStudio Settings.....	27
Making the Setting for the Printer	27
Chapter 3 Making Prints.....	29
3-1 Switching the Power On and Off	30
Switching On the Power	30
Switching Off the Power	31
3-2 Getting Ready	32
The Printable Area.....	32
Head Caps	32
Preparing Material to Print.....	33
Loading Material Using the Adhesive Sheet.....	36
Using the Center Vise	40
Loading Material Using the Center Vise	41
3-3 Preparing Print Data (METAZAStudio).....	44
Starting METAZAStudio	44
METAZAStudio Screen.....	45
Step1 : Determine the shape and size of material.....	46
Step2 : Import the Image	48
Step3 : Enter the Text.....	50
Step4 : Save Printing Data	50
3-4 Starting and Stopping Printing	52
Starting Printing.....	52

Stopping Printing Operations.....	54
Chapter 4 More Advanced Operations.....	57
4-1 Tips and Tricks for Image Layout.....	58
Keeping Only the Required Portion of an Image (Trimming)	58
Adjusting the Location, Size, or Angle of an Image	59
Enclosing an Image in a Frame.....	62
4-2 Tips and Tricks for Text Layout.....	64
Adjusting the Location, Size, or Angle of a Text	64
Arranging a Text to a Fan Layout	66
Laying Out Text along a Shape.....	67
Filling Text	68
4-3 Creating and Editing Line Text	70
SFEdit2 window	70
Creating a Stroke Character Font.....	71
Changing Input Characters into Stroke Characters	73
Editing Stroke character.....	74
4-4 Checking and Adjusting Finished Result of an Image.....	75
Checking the Finished Results in the Preview Window	75
Adjusting the Finished Result in the Preview Window	76
4-5 Printing on a Curved Surface	77
Step1 : Decide on the Printing Area (Workpiece Size)	77
Step2 : Make horizontal writing on portrait material.....	80
4-6 Register New Material.....	82
How to Register Wide Variety of Material	82
4-7 METAZA Driver Settings	83
Keeping the settings of METAZA Driver	83
4-8 About Dr. Engrave	84
What is Dr. Engrave?	84
Points to note when using Dr. Engrave	84
4-9 More Advanced Other Operations	85
More Advanced Other Operations You Can Accomplish with METAZAStudio	85
Chapter 5 Maintenance and Adjustment	87
5-1 Daily Care	88
Points to Note on Daily Care.....	88
Cleaning the Adhesive Sheet	88
Cleaning the Body and Cover	89
Cleaning of the Head Cap	89
5-2 Adjusting the Marking Pin	90
Checking the State of the Marking Pin.....	90
Adjusting the Striking Force of the Pin.....	91
5-3 Composition Registration and Striking-force Adjustment.....	92
Registering a Composition and Adjusting the Striking Force	92
5-4 Adjustment of the Origin-point Location	95
Adjusting the Location of the Machine's Origin Point.....	95
5-5 The Replacement of the Head Cap.....	98
The Replacement Cycle for the Head Cap	98

5-6 Head Replacement	99
The Replacement Cycle for the Head	99
How to Replace the Head.....	100
Chapter 6 Appendix	103
6-1 What to Do If	104
The power supply light is blinking	104
The machine doesn't run even when printing data is sent.....	104
The printed location isn't where desired	104
Striking is performed, but nothing is printed.	105
The printed image is unattractive.	105
The image is uneven.	106
The image is always faint at the same location.	106
Installation for METAZA driver is Impossible	107
Uninstalling METAZA driver.....	108
6-2 When Moving the Machine	111
Attach the retaining materials to the machine.....	111
6-3 Locations of the Power Rating and Serial Number Labels.....	114
6-4 Specification.....	115
Main Unit Specifications	115
System Requirements for USB Connection.....	115
Please read this Agreement before unpacking the media.....	IV



Windows® is a registered trademark or trademark of Microsoft® Corporation in the United States and/or other countries. Company names and product names are trademarks or registered trademarks of their respective holders.









To Ensure Safe Use

Improper handling or operation of this machine may result in injury or damage to property. Points which must be observed to prevent such injury or damage are described as follows.

About WARNING and CAUTION Notices

 WARNING	Used for instructions intended to alert the user to the risk of death or severe injury should the unit be used improperly.
 CAUTION	Used for instructions intended to alert the user to the risk of injury or material damage should the unit be used improperly. * Material damage refers to damage or other adverse effects caused with respect to the home and all its furnishings, as well to domestic animals or pets.

About the Symbols

	The  symbol alerts the user to important instructions or warnings. The specific meaning of the symbol is determined by the design contained within the triangle. The symbol at left means "danger of electrocution."
	The  symbol alerts the user to items that must never be carried out (are forbidden). The specific thing that must not be done is indicated by the design contained within the circle. The symbol at left means the unit must never be disassembled.
	The  symbol alerts the user to things that must be carried out. The specific thing that must be done is indicated by the design contained within the circle. The symbol at left means the powercord plug must be unplugged from the outlet.



Incorrect operation may cause injury

WARNING



Keep children away from the machine.

The machine includes areas and components that pose a hazard to children and may result in injury, blindness, choking, or other serious accident.



Never attempt to disassemble, repair, or modify the machine.

Doing so may result in fire, electrical shock, or injury. Entrust repairs to a trained service technician.

CAUTION



Install in a location that is level and stable.

Installation in an unsuitable location may cause an accident, including a fall or tip over.



Be sure to follow the operation procedures described in this documentation. Never allow anyone unfamiliar with the usage or handling of the machine to touch it.

Incorrect usage or handling may result in unexpected injury.

 **Danger of electrical short, shock, electrocution, or fire**

 **WARNING**



Connect to an electrical outlet that complies with this machine's ratings (for voltage, frequency, and current). Incorrect voltage or insufficient current may cause fire or electrical shock.

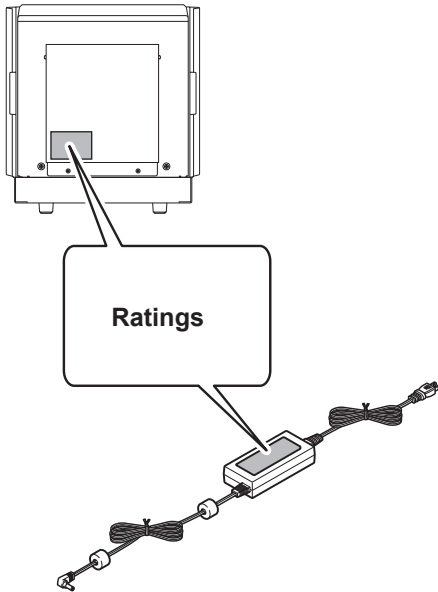

Do not use with any power supply other than the dedicated AC adapter. Use with any other power supply may lead to fire or electrocution.



Never use out of doors or in any location where exposure to water or high humidity may occur. Never touch with wet hands. Doing so may result in fire or electrical shock.



Never allow any foreign object to get inside. Never expose to liquid spills. Inserting objects such as coins or matches or allowing beverages to be spilled into the ventilation ports may result in fire or electrical shock. If anything gets inside, immediately disconnect the power cord and contact your authorized Roland DG Corp. dealer.



Never place any flammable object nearby. Never use a combustible aerosol spray nearby. Never use in any location where gases can accumulate. Combustion or explosion may be a danger.



Handle the power cord, plug, and electrical outlet correctly and with care. Never use any article that is damaged. Using a damaged article may result in fire or electrical shock.



When using an extension cord or power strip, use one that adequately satisfies the machine's ratings (for voltage, frequency, and current). Use of multiple electrical loads on a single electrical outlet or of a lengthy extension cord may cause fire.



When the machine will be out of use for a prolonged period, disconnect the power cord. This can prevent accidents in the event of current leakage or unintended startup.



Position so that the power plug is within immediate reach at all times. This is to enable quick disconnection of the power plug in the event of an emergency. Install the machine next to an electrical outlet. Also, provide enough empty space to allow immediate access to the electrical outlet.



If sparking, smoke, burning odor, unusual sound, or abnormal operation occurs, immediately unplug the power cord. Never use if any component is damaged. Continuing to use the machine may result in fire, electrical shock, or injury. Contact your authorized Roland DG Corp. dealer.

 Important notes about the power cord, plug, and electrical outlet

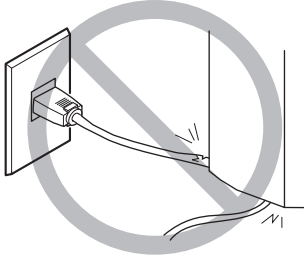

Never place any object on top or subject to damage.



Never allow to get wet.

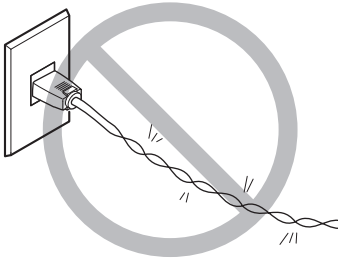

Never bend or twist with undue force.

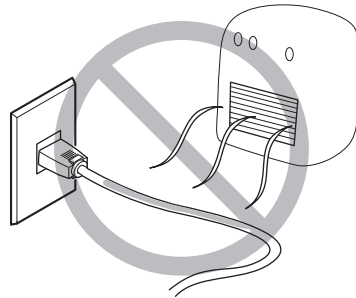

Never make hot.

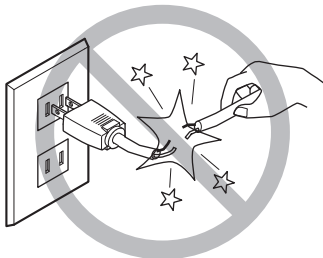

Never pull with undue force.

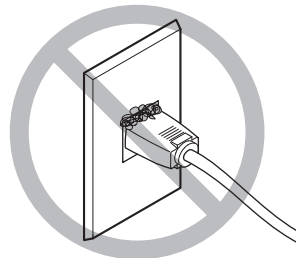

Dust may cause fire.

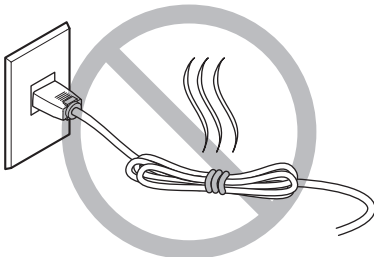

Never bundle, bind, or roll up.

 **The head area becomes hot**

 **WARNING**



Never touch the head immediately after printing has finished.
Doing so may cause burns.

 **Warning Label**

Warning label is affixed to make areas of danger immediately clear. The meaning of the label is as follows. Be sure to heed its warnings.
Also, never remove the label or allow it to become obscured.

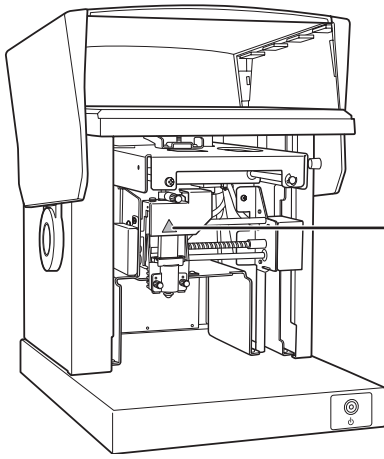

Caution: High Temperature
Never touch immediately after printing.

Important Notes on Handling and Use

This machine is a precision device. To ensure the full performance of this machine, be sure to observe the following important points. Failure to observe these may not only result in loss of performance, but may also cause malfunction or breakdown.

This Machine is a Precision Device.

- Handle carefully, and never subject the machine to impact or excessive force.
- Never print material outside the range of specifications.

Install in a Suitable Location

- Install in a location having the specified temperature and relative humidity.
- Install in a quiet, stable location offering good operating conditions.
- Never use the machine in an environment where silicone substances (oil, grease, spray, etc.) are present. Doing so may cause poor switch contact.

When Moving the Machine

- When moving the machine, be sure to support it at the bottom using two hands. Attempting to move the machine by holding it at a different location may result in damage.
- When moving the machine to another location, be sure to attach the retainers. Attempting moving without attaching the retainers may result in damage.

Printing

- Never attempt to perform printing on the edges or over holes in printing material.
- Printing results may vary according to the original data, the material printed, and the details of settings. Before you perform actual printing, we recommend carrying out test printing.
- Attempting printing with no material loaded may damage the pin or heads.

About Operation Manuals

Documentation Included with the Machine

The following documentation is included with the machine.

➤ **MPX-90 User's Manual (this manual)**

This describes important notes for ensuring safe use, and explains how to install and operate the machine. It also explains how to install and operate included software. Be sure to read it first.

➤ **METAZA Driver Online Help**

➤ **Roland METAZAStudio Online Help**

➤ **Roland SFEdit2 Online Help**

➤ **Dr. Engrave Online Help**

You view this documentation on your computer screen. Installing the respective programs makes these available for viewing. They describe in detail the commands used in the programs.

☞ P.10, "How to Display Help for Software," p.11, "How to Display Help for METAZA Driver"

How to Display Help for Software

You can display Help for software by conducting the following operation after installing the software.

☞ P.26, "Installing the Software"

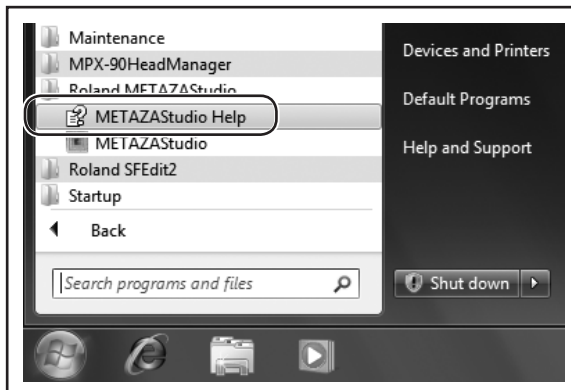

From [Start] menu, select software and click [Help].

How to Display Help for METAZA Driver

You can display Help for METAZA driver by conducting the following operation after installing METAZA driver.

☞ P.25, "Installing METAZA Driver"

Procedure

1 Windows 7

From [Start] menu, click [Control Panel] → [Hardware and Sound] → [Devices and Printers].

Windows Vista

From [Start] menu, click [Control Panel] → [Hardware and Sound] → [Printers].

Windows XP

From [Start] menu, click [Control Panel] → [Printers and Other Hardware] → [Printers and Faxes].

2

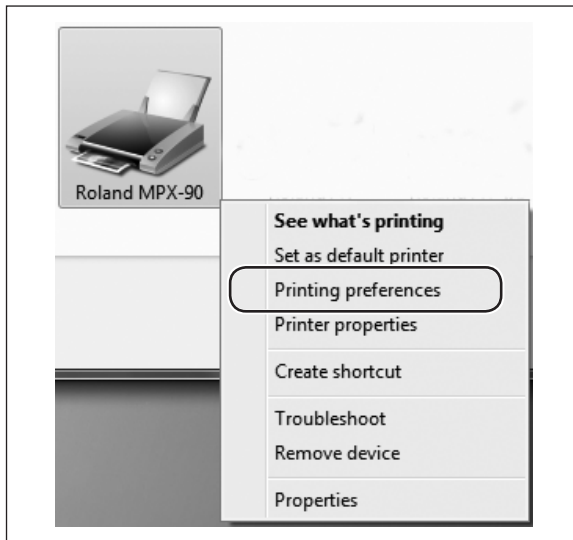

Right click [Roland MPX-90].
Click [Printing Preferences].

The setting window appears.

Continue on the next page

3

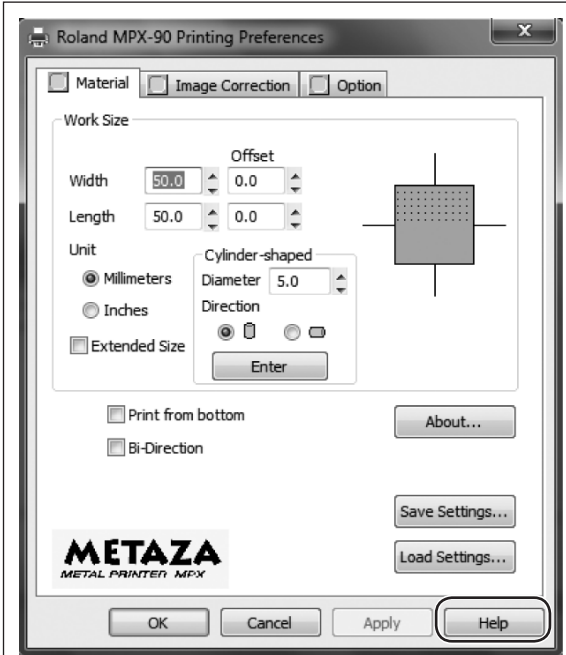

Click [Help].
METAZA Driver help appears.

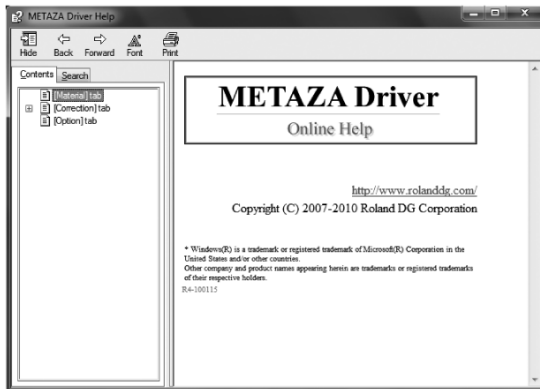

Chapter 1

Getting Started

1-1 About the Machine	14
Features	14
1-2 Names and Functions	15
This Machine	15
1-3 Checking the Included Items	17

1-1 About the Machine

Features

This machine is a metal printer. It prints images by striking detailed points using a marking pin mounted in a head.

1-2 Names and Functions

This Machine

Main Unit

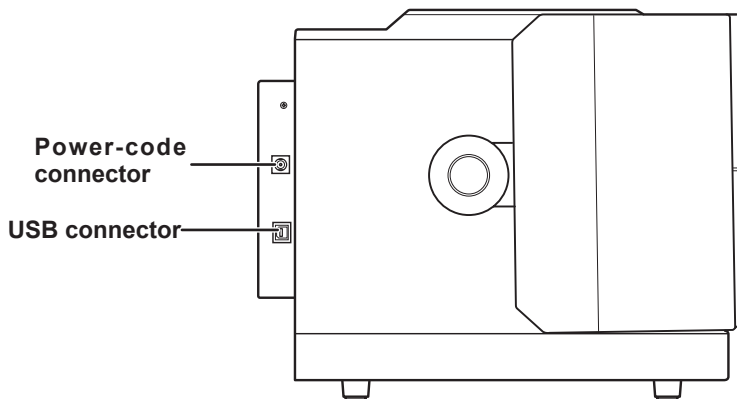
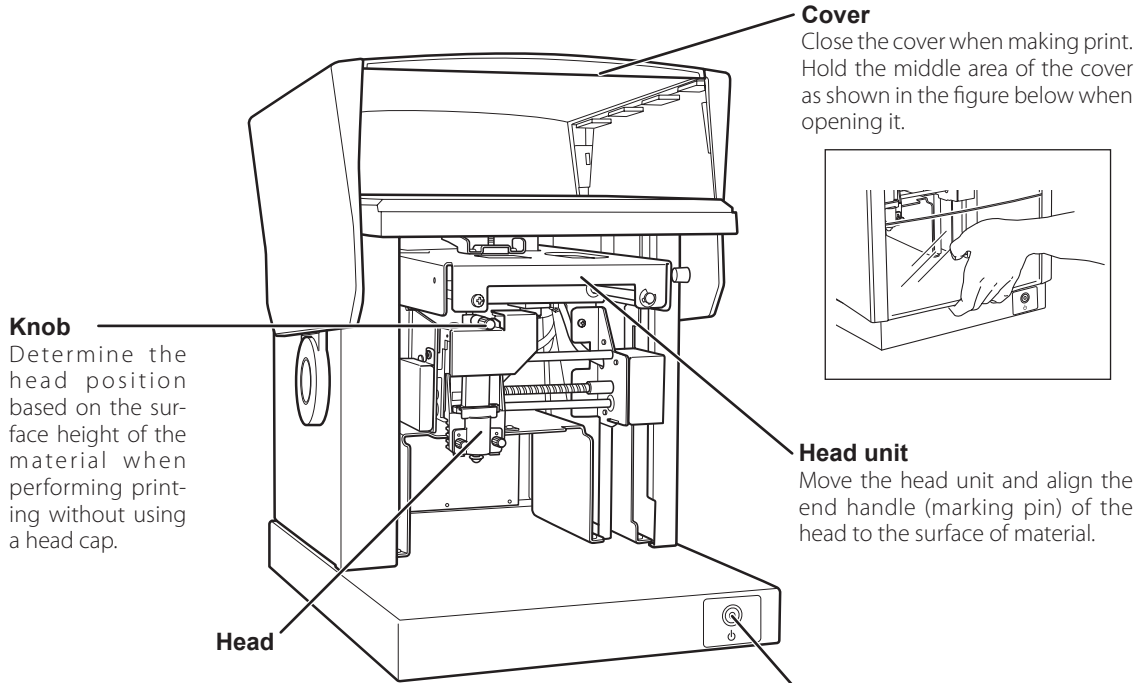

Head (MPH-90)

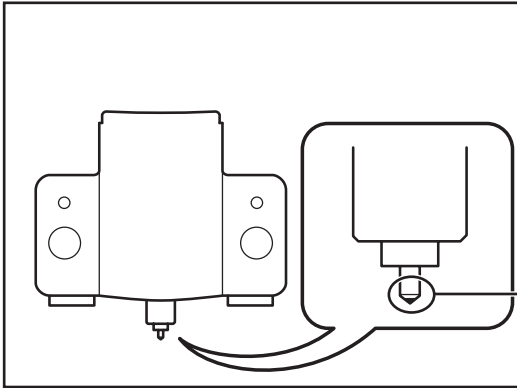

Printing is performed on material using with a marking pin. Diamond is attached to the tip of the marking pin. Since the head is a consumable part, replace it at an appropriate timing.
☞ P. 99, "The Replacement Cycle for the Head"

Marking pin

Material Retainers

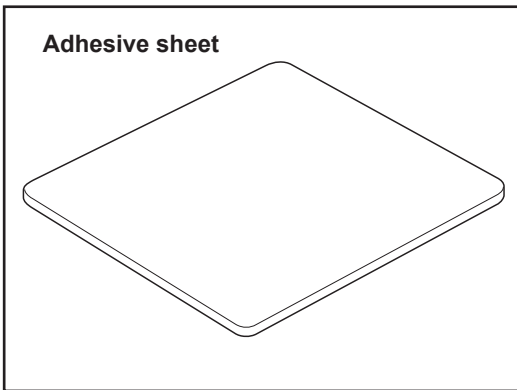

Adhesive sheet

This is used to fix material on a table. Material is placed on the adhesive sheet, which then holds the material in place. This lets you immobilize objects without having to use commercially available tape or the like.
☞ P. 36, "Loading Material Using the Adhesive Sheet"

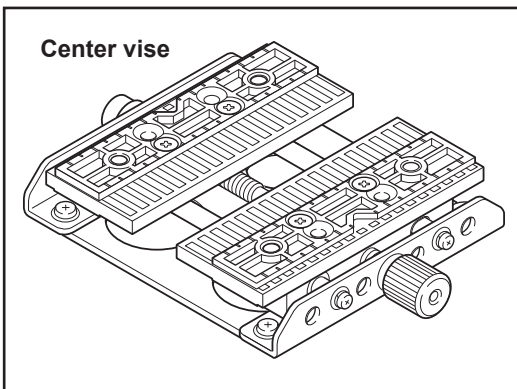

Center vise

This is a vise made of plastic, and secures material in place by clamping it. This makes it possible to immobilize material that cannot be secured using the adhesive sheet, such as items having a curved bottom surface. The act of securing an item in place also accurately determines the center position in the horizontal direction.
☞ P. 41, "Loading Material Using the Center Vise"

1-3 Checking the Included Items

The following items are packed together with the unit. Make sure they are all present and accounted for.

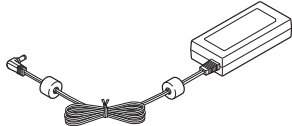
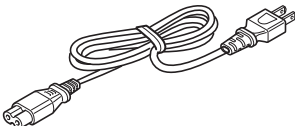
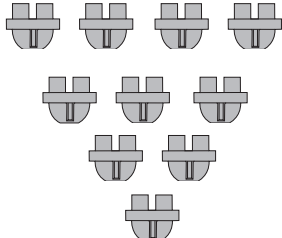
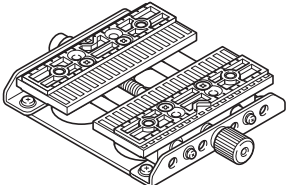
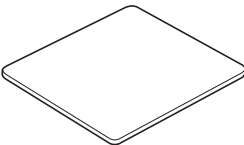
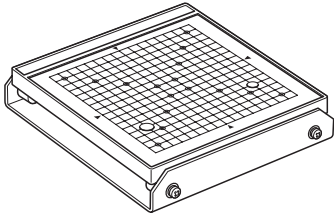
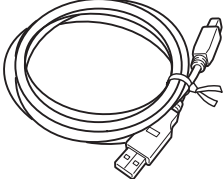
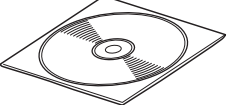
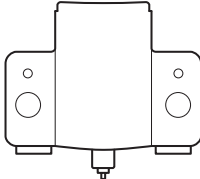
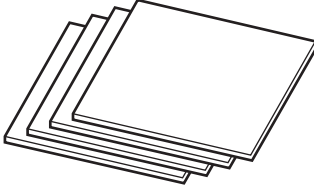
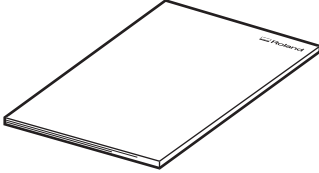
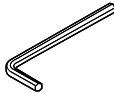
 <p>AC adapter (1)</p>	 <p>Power cord (1)</p>	 <p>Head caps (10) (One installed on the unit by default)</p>
 <p>Center vise (1)</p>	 <p>Adhesive sheet (1)</p>	 <p>Table (1)</p>
 <p>USB cable (1)</p>	 <p>Roland Software Package CD-ROM (1)</p>	 <p>Head (MPH-90) (1) (Installed on the unit by default)</p>
 <p>Test-use printing material (4) (Brass-plated plates)</p>	 <p>User's manual (1) (This document)</p>	 <p>Hexagonal wrench (1)</p>

Chapter 2

Installation and Setup

2-1 Installation.....	20
Installation Environment	20
Removing and storing the retainers.....	21
2-2 Cable Connections	23
Connecting the machine to a power supply.....	23
2-3 Installing the Software	24
System Requirements	24
The Software You Can Install and Set Up	24
Installing METAZA Driver.....	25
Installing the Software	26
2-4 METAZASudio Settings	27
Making the Setting for the Printer	27

2-1 Installation

Installation Environment

Install in a quiet, stable location offering good operating conditions. An unsuitable location can cause accident, fire, faulty operation, or breakdown.

CAUTION

Install in a location that is level and stable.

Installation in an unsuitable location may cause an accident, including a fall or tip over.

- Never install in a location subject to wide fluctuations in temperature or humidity.
- Never install in a location subject to shaking or vibration.
- Never install in a location where the floor is tilted, not level, or unstable.
- Never install in a dusty or dirty location, or out of doors.
- Never install in a location exposed to direct sunlight or near air-conditioning or heating equipment.
- Never install in a location exposed to considerable electrical or magnetic noise, or other forms of electromagnetic energy.
- Never install in an environment where silicone substances (oil, grease, spray, etc.) are present.

Removing and storing the retainers

Retaining materials are attached to protect the machine from vibration during shipment. Remove these after emplacement.

- Remove all Retaining materials. Any that remain may cause faulty operation or breakdown when the power is switched on.
- The retaining materials and package are required when moving the machine to a different location. Store them carefully so that they do not get misplaced.

Removing the retainers

The machine is secured at three points (with 5 screws). Remove all the screws and retainers with the provided hexagonal wrench.

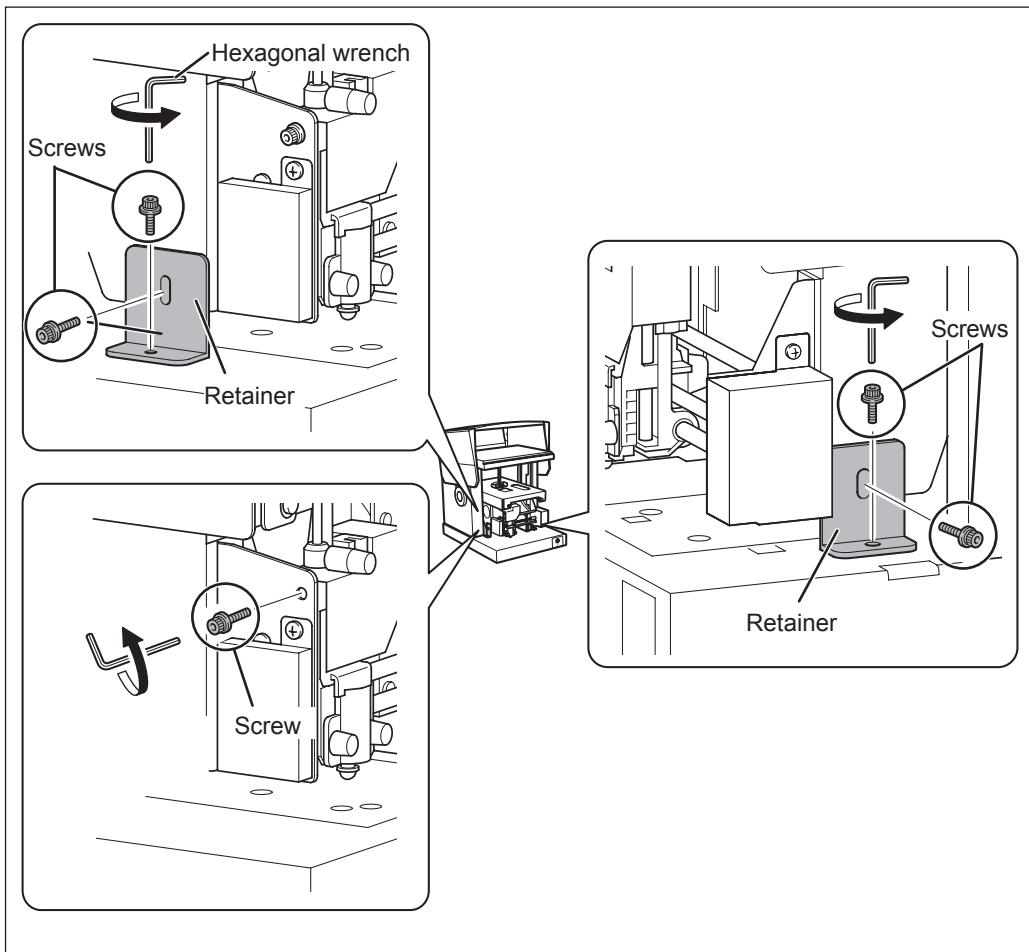

Continue on the next page

Storing the retainers

Keep the retaining materials by mounting them to the position shown in the figure.

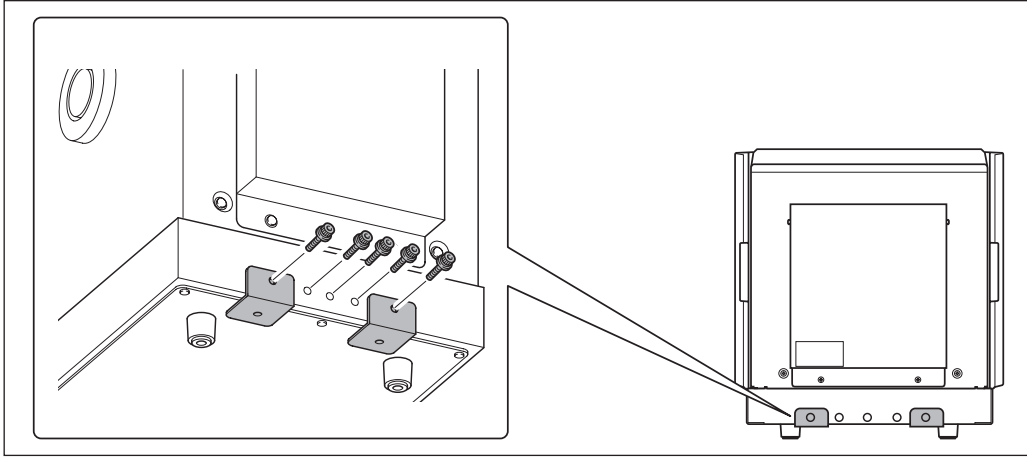

2-2 Cable Connections

Connecting the machine to a power supply

! Notice

At this time, the connection to the computer must not be made yet.

Failure to follow the correct procedure may make installation impossible. You make the connection to the computer when you install METAZA driver.

☞ P. 25, "Installing METAZA Driver"

- !** **WARNING** Do not use with any electrical power supply that does not meet the ratings displayed on the AC adapter.
Use with any other power supply may lead to fire or electrocution.
- !** **WARNING** AC Never use any AC adapter and power cord other than the AC adapter and power cord included with the machine.
Doing so may lead to fire, electrical shock, or electrocution.
- !** **WARNING** Handle the power cord, plug, and electrical outlet correctly and with care. Never use any article that is damaged.
Using a damaged article may result in fire or electrical shock.
- !** **WARNING** When using an extension cord or power strip, use one that adequately satisfies the machine's ratings (for voltage, frequency, and current).
Use of multiple electrical loads on a single electrical outlet or of a lengthy extension cord may cause fire.

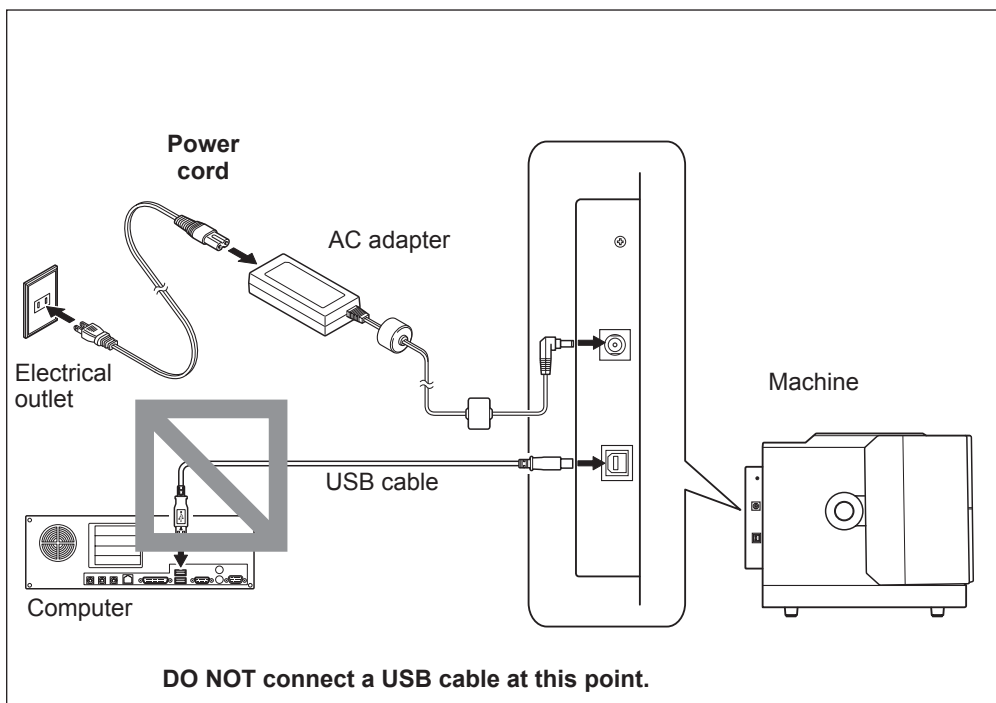

2-3 Installing the Software

System Requirements

Operating system *	Windows XP/Vista/7 (32 bit edition/64 bit edition)
Processor	Intel® Core 2 Duo or greater (Core i5 or greater recommended)
Memory	1 GB or greater (2 GB or more recommended)
Optical drive	CD-ROM drive
Video card and monitor	At least 16 bit colors (High Color) with a resolution of 1024 x 768 or more recommended
Free hard-disk space required for installation	25 MB

* As this software is a 32-bit application, it runs on WOW64 (or Windows-On-Windows 64) under the 64-bit version of Windows.

For the latest information, see the Roland DG Corp. website (<http://www.rolanddg.com>).

The Software You Can Install and Set Up

METAZASudio	This is a program for creating printing data. It enables you import and crop images to print, and perform editing to add text, boxes, and the like.
SFEdit2	This is a program that lets you create and edit stroke fonts. Stroke fonts are line drawings created by automatically extracting the centerlines from a TrueType font. You can use the generated stroke fonts as fonts with METAZASudio.
MPX-90 Head Manager	This is a utility for adjusting the head. Run it when you replace the head or adjust the marking pin.
Dr. Engrave	This is text and image printing software that lets you create print data. You can use TrueType fonts registered in Windows. It also has stroke characters.
METAZA Driver	This is a Windows-based driver required for sending data from a computer to the machine.

Installing METAZA Driver

! Notice

Make sure to connect the machine to a computer by following the given procedure. Failure to follow the correct procedure may make installation impossible.

Procedure

- 1 Before you start installation and setup, make sure the USB cable is NOT connected.
- 2 Log on to Windows as “Administrators.”
- 3 Insert the Roland Software Package CD-ROM into the computer.
When the automatic playback window appears, click [Run menu.exe].
The install menu appears automatically.

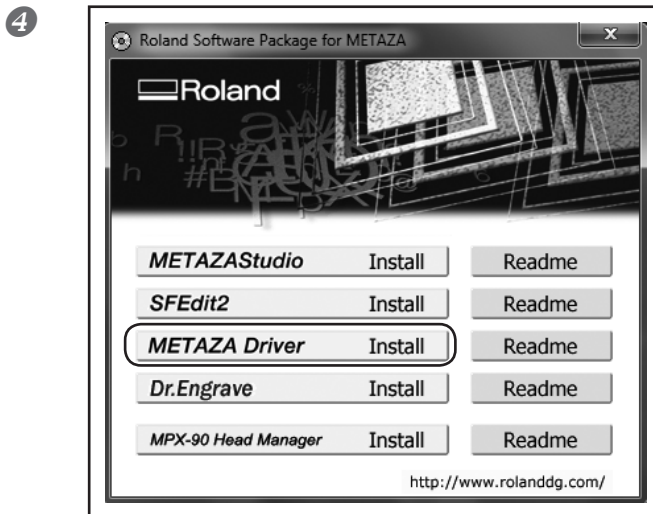

Click [METAZA Driver Install].

The Installation and Setup Guide appears on the screen. When [User Account Control] is displayed on the screen, click [YES].

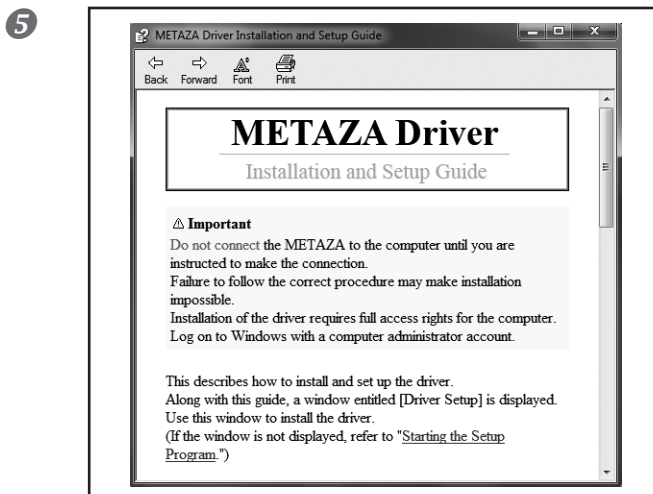

Follow the instructions in the Setup Guide to finish installing.

As following the instructions in the Setup Guide, you will find the procedure to connect the machine to a computer. Make sure to keep the instructions given below.

- Never connect two or more machines to one computer.
- For the USB cable, use the included cable.
- Never use a USB hub.

6

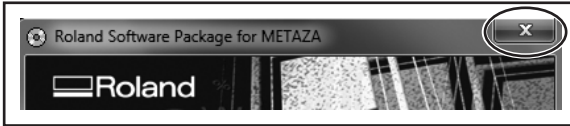

Click  of the install menu window and setup guide window.

Installing the Software

Procedure

1 Display the window for the install menu of the software.

2



Click [Install] of the program you want to install.

3 Follow the messages to install the software.

The [User Account Control] appears, click [Allow], and install the softwares.

4



When all installation finishes, click  of the install menu.

5 Remove the CD-ROM from the CD-ROM drive.

2-4 METAZAStudio Settings

Making the Setting for the Printer

After you finish installing and setting up METAZAStudio, continue by making the setting for the printer. Be sure to make the setting before use.

Procedure

1

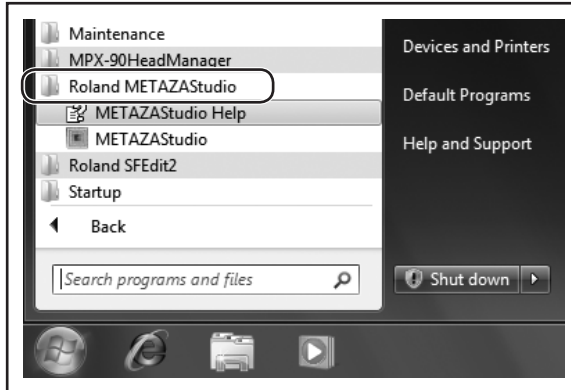

From [Start] menu, click [All Programs] (or [Programs]) → [Roland METAZAStudio] → [METAZAStudio].

METAZAStudio starts.

2

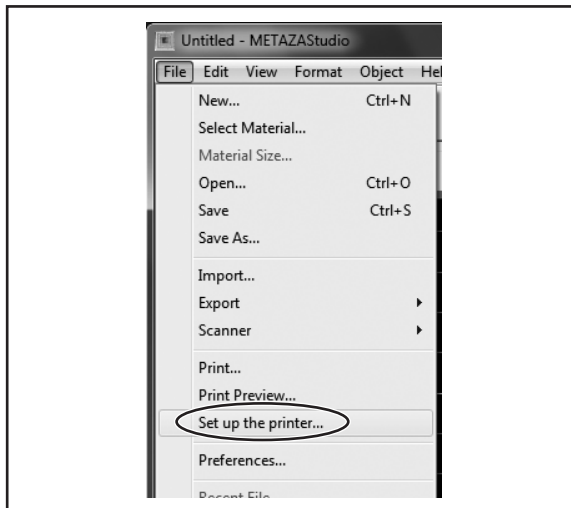

Click [File] → [Set up the printer].

The [Print Setup] dialog box appears.

3

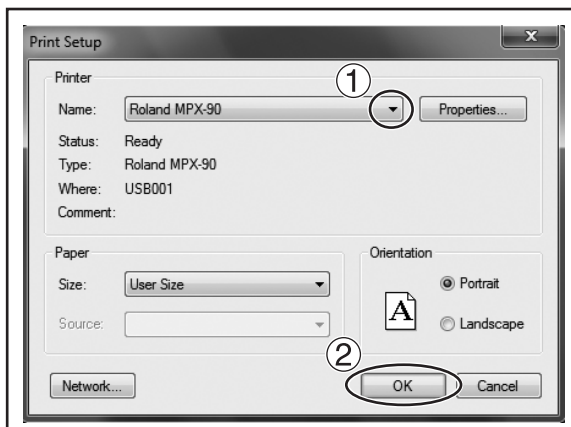

1 Click the arrow shown in the figure, then select [Roland MPX-90].

2 Click [OK].

Chapter 3

Making Prints

3-1 Switching the Power On and Off	30
Switching On the Power	30
Switching Off the Power	31
3-2 Getting Ready	32
The Printable Area	32
Head Caps	32
Preparing Material to Print.....	33
Loading Material Using the Adhesive Sheet.....	36
Using the Center Vise	40
Loading Material Using the Center Vise	41
3-3 Preparing Print Data (METAZASudio)	44
Starting METAZASudio	44
METAZASudio Screen.....	45
Step1 : Determine the shape and size of material.....	46
Step2 : Import the Image	48
Step3 : Enter the Text.....	50
Step4 : Save Printing Data	50
3-4 Starting and Stopping Printing	52
Starting Printing.....	52
Stopping Printing Operations.....	54

3-1 Switching the Power On and Off

Switching On the Power

Procedure

1

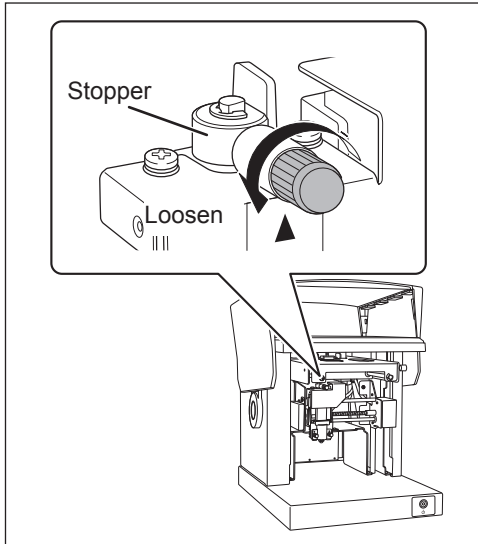

Open the cover and loosen the head's stopper.

2

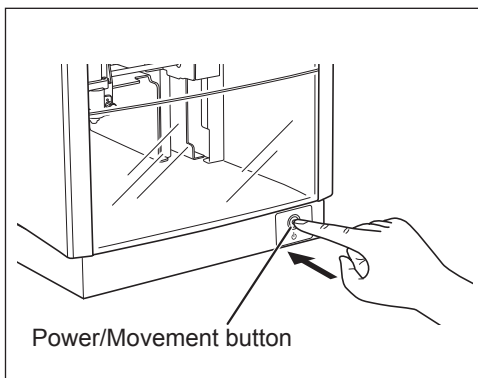

Press the Power/Movement button.

The Head moves to the left rear, and the lamp of the Power/Movement button is turned ON. This operation is called initialization.

When the power lamp remains blinking

An initialization error. Loosen the stopper of the head, and then press the Power/Movement button. The error is cleared, and the power lamp is lit.

Switching Off the Power

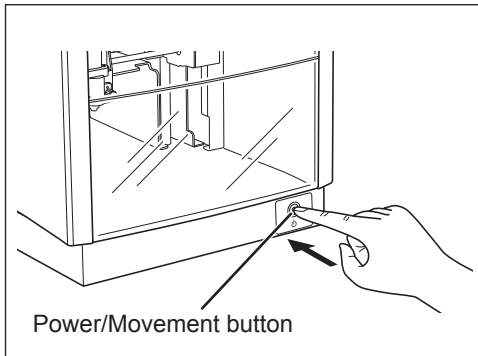

Hold down the Power/Movement button for one second or longer.

The light goes dark and the power is switched off.

3-2 Getting Ready

The Printable Area

The machine's printable area is as follows.

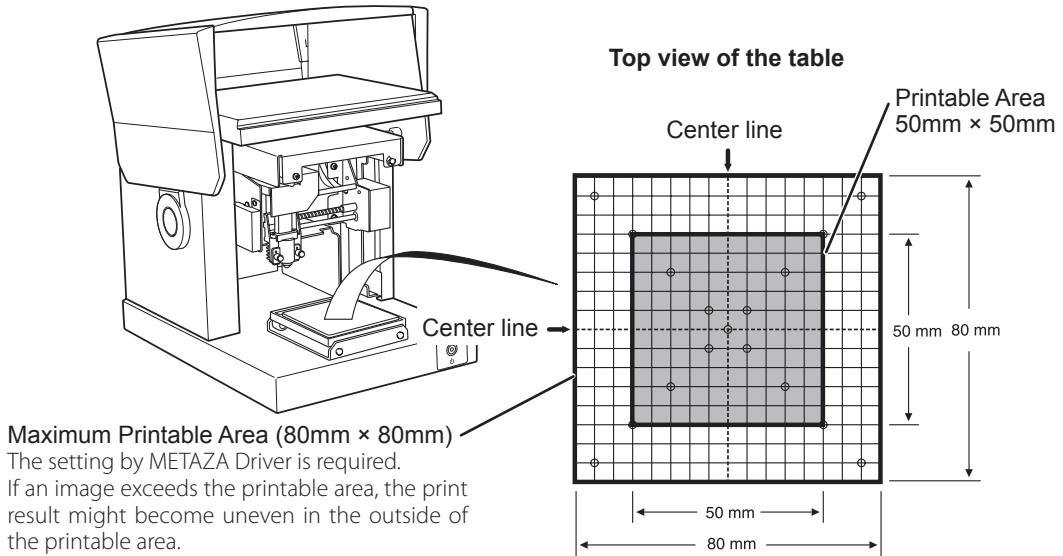

Head Caps

Using the head cap is usually recommended.

When the head cap is used, the machine automatically tracks the surface height of material and sets the position of the head. Therefore you do not need to set the head position for printing. You can make a print even on a cylindrical material. (There is an upper limit of the height that can be tracked.) It is recommended to use the head cap for usual printing.

☞ P. 77, "4-5 Printing on a Curved Surface," p. 98, "The Replacement Cycle for the Head Cap"

Remove dirt and dust from the printing surface.

If you carry out printing without removing dirt and dust attached to the printing surface, it may deteriorate the printing quality. Make sure to remove dirt and dust from the printing surface before you perform printing.

For test printing, it is advisable to use materials with no scratches or stains.

Some materials may cause scratches and stains on the head cap during printing, which may affect the printing quality. Scratches and stains on the materials may also damage the head cap and result in poor-quality printing. Therefore, for your prior checks on printing, we recommend you perform test printing with materials without any scratches or stains.

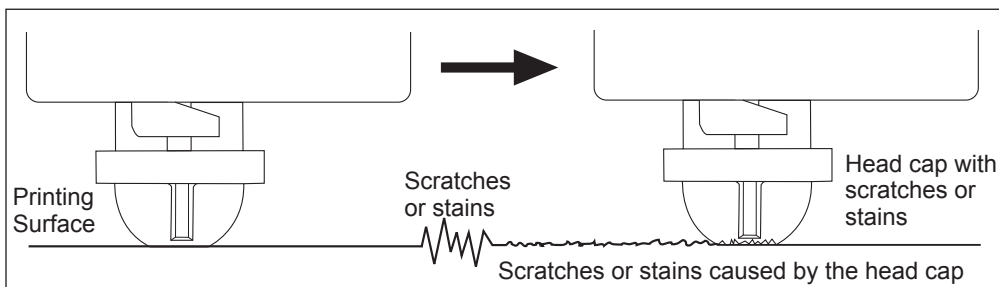

Preparing Material to Print

Prepare material that meets all of the following conditions.

Thickness *1

0.3 to 40 mm (0.012 to 1.5 in.)

Size *1

When using the adhesive sheet: 100mm (3.9 in.) (W) × 200mm (7.9 in.) (L) or less, or 200mm (7.9 in.) (W) × 100mm (3.9 in.) (L) or less.

When using the center vise: 60 mm (2.3 in.) (W) × Length of 200mm (7.9 in.) (L) or less, or 200mm (7.9 in.) (W) × 60 mm (2.3 in.) (L) or less.

*1

Note that you cannot use material which warps during printing even if the thickness and size are within the ranges specified above. If you use such material, warped material might come into contact with the head, damaging the marking pin.

The following table shows the printable thickness and size by material.

Material	Thickness	Width and Length (general guide)
Aluminium	2.0 mm (0.08 in.)	Length (or width) of 60 mm (2.3 in.) or less
	1.5 mm (0.06 in.)	Length (or width) of 40 mm (1.5 in.) or less
	1.0 mm (0.04 in.)	Length (or width) of 30 mm (1.1 in.) or less
	0.5 mm (0.02 in.)	Length (or width) of 20 mm (0.7 in.) or less
	0.3 mm (0.01 in.)	Length (or width) of 20 mm (0.7 in.) or less
Brass or Copper	2.0 mm (0.08 in.)	Length (or width) of 60 mm (2.3 in.) or less
	1.5 mm (0.06 in.)	Length (or width) of 40 mm (1.5 in.) or less
	1.0 mm (0.04 in.)	Length (or width) of 30 mm (1.1 in.) or less
	0.5 mm (0.02 in.)	Length (or width) of 15 mm (0.5 in.) or less
	0.3 mm (0.01 in.)	Length (or width) of 15 mm (0.5 in.) or less
Stainless steel	2.0 mm (0.08 in.)	Length (or width) of 60 mm (2.3 in.) or less
	1.0 mm (0.04 in.)	Length (or width) of 40 mm (1.5 in.) or less

*2

The mounting direction of the vise might be limited.

☞ P. 41, "Loading Material Using the Center Vise"

Hardness of surface to print

Vickers hardness (HV) of 200 or less *3

*3

Materials which may crack or split by printing (such as glass, stone, precious stones, china, and porcelain) cannot be printed even if hardness is within the preceding range.

Attempting to print such materials may damage the machine.

For information of the hardness of the material surface, please contact the shop where you bought the material or the manufacturer of the material.

Cross-section of printing material

When using an adhesive sheet or a center vice.

➤ There must be no unevenness on the print surface. *4

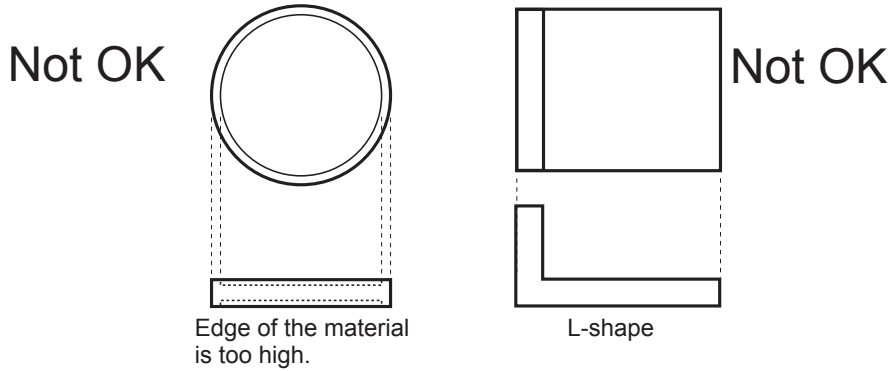

*4

Materials that cannot be used are those of which unevenness comes into contact with the moving part of the machine when material is set or when printing is made.

When using an adhesive sheet.

➤ The back surface must be flat, with no difference in level.

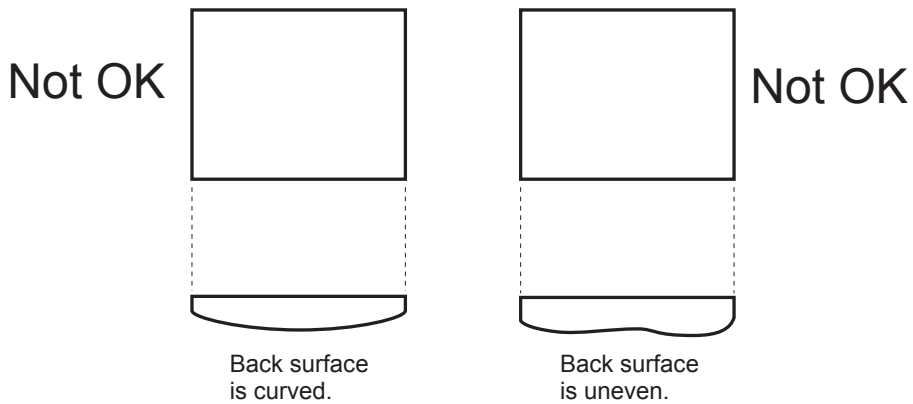

Without a head cap

➤ The printed surface must be level.

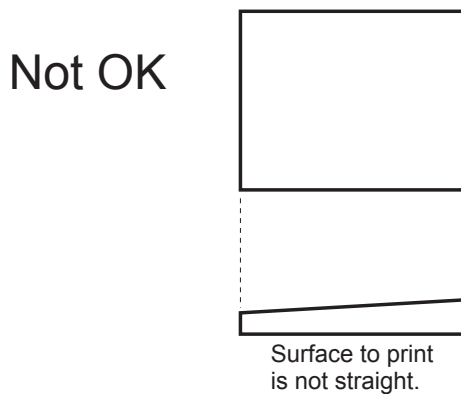

Conditions for Material When Printing Curved Surfaces *5

The table and figure below show the printing-assured area and the area reached by the marking pin with respect to the diameter of the cylinder. Note, however, that the following conditions are assumed.

- The head cap is used.
- The material has circularity.

Diameter of cylindrical material	Recommended printable area (A)	Area reached by the marking pin (B)
10 mm (0.3 in.)	2.0 mm (0.079 in.)	2.8 mm (0.11 in.)
20 mm (0.7 in.)	2.8 mm (0.11 in.)	4.0 mm (0.16 in.)
30 mm (1.1 in.)	3.4 mm (0.14 in.)	4.8 mm (0.19 in.)

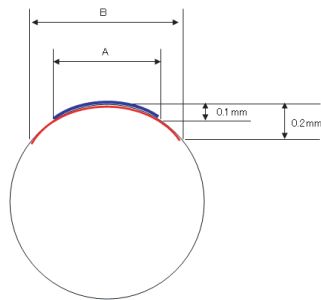

*5

For printing on curved surfaces, regardless of the shape or composition of the material, the image quality of photographic data cannot be assured.

Loading Material Using the Adhesive Sheet

Procedure

1 Switch on the power

⇨ P.30, "Switching On the Power"

2

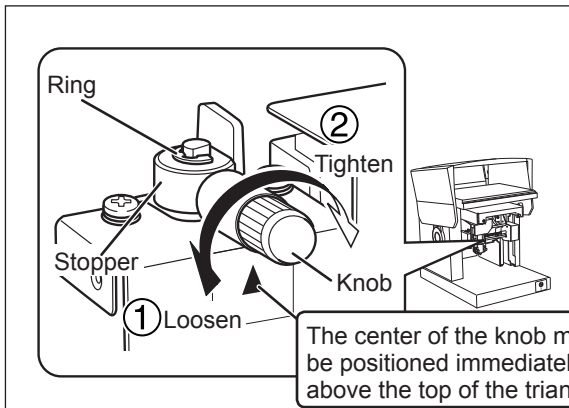

1 Loosen the head's stopper.

The stopper and ring contact each other.

2 Fix the head's stopper.

Align the center of the knob with the top of the triangle right below and then secure the stopper.

If you printing as the stopper is loose, the knob might come off due to vibration.

3

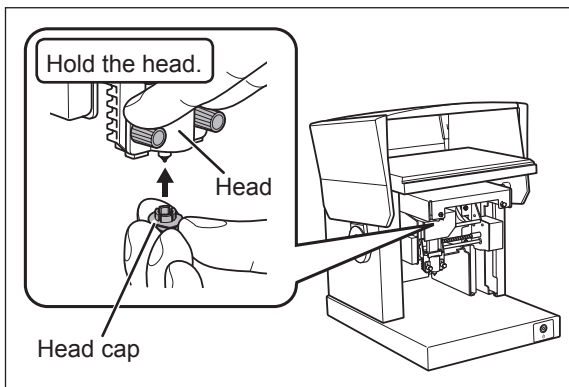

Attach a head cap to the tip of head.

Mount it as lightly holding the head as shown in the figure. The head cap is attached correctly when its tab clicks.

4

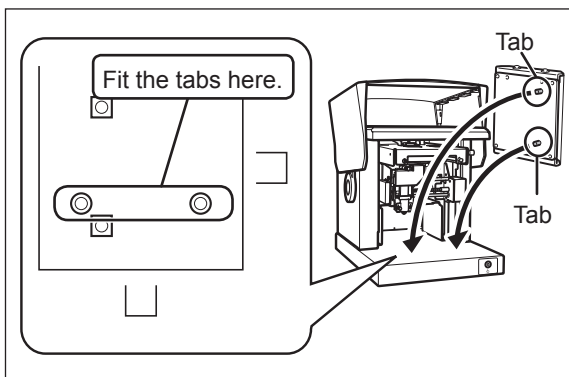

Set the table.

Fit the tabs on the base of the table to the holes of the machine.

5

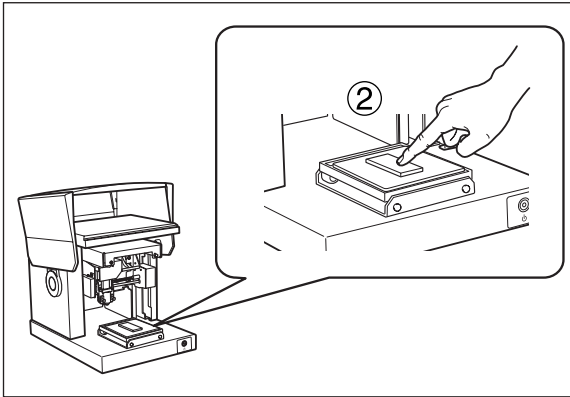

① **Affix the adhesive sheet to the table.**

② **Mount the material on the sheet.**
Press down lightly on the material to secure it in place.



Point

Mounting the Adhesive Sheet

- Place it straight, aligned with the scale marks on the table.
- Place inside the table frame.
- Be careful not to allow any air bubbles to form between the adhesive sheet and the table.

Handling of the Adhesive Sheet

- If the adhesive force has been reduced, then wash the adhesive sheet.
- ☞ P. 88, "Cleaning the Adhesive Sheet"
- Never rub the surface with force. Doing so may damage the surface and reduce its adhesive strength.

How to Place Material

When material is small enough to be placed within the table

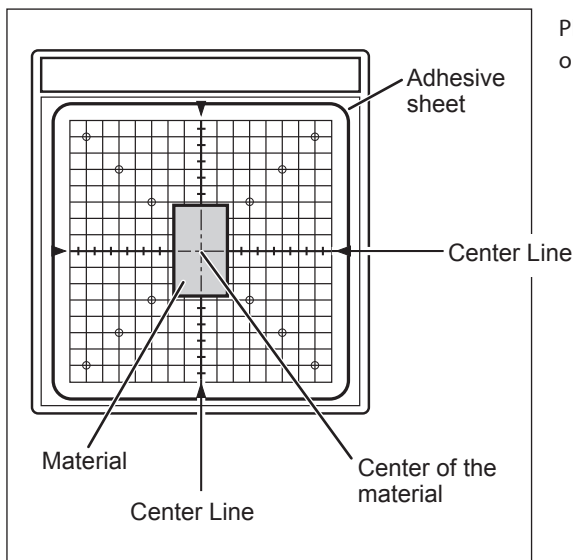

Place the material at the center of the scale on the table.

Continue on the next page

When material is too large to be placed within the table

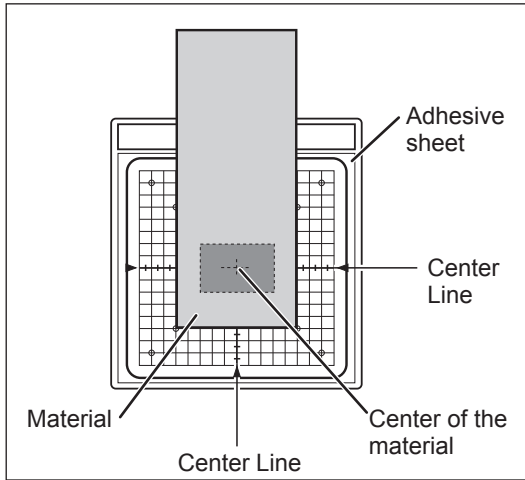

Place the material in a way that the center of the printing area comes to the center of the scale on the table. If the material tilts, place a support in order to keep the material horizontal.

If you're performing printing with head cap used, this completes loading of the material. If you're performing printing with no head cap used, then go on to the following steps.

The procedure from this point on is for when you're not using the head cap.

6

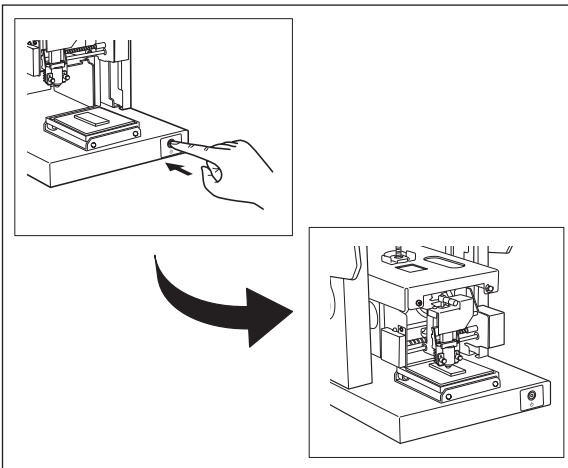

Press the Power/Movement button.

The head moves and stops at the position where the tip of the head cap rides on the surface of the material.

7

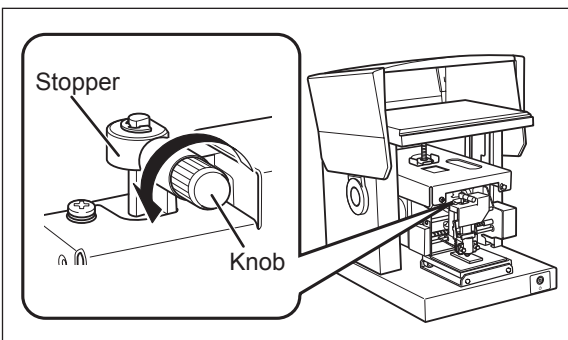

Loosen the knob.

Rotate the knob counterclockwise once. Then you can move the stopper.

8

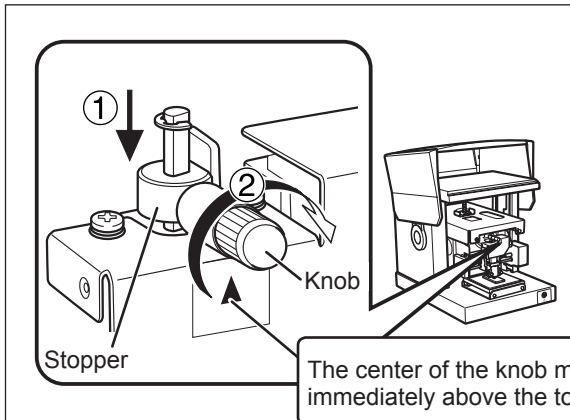

① As shown in the figure, move the knob to the lowest position.

② Tighten the knob.

Align the center of the knob with the top of the triangle right below and then secure the stopper.

9

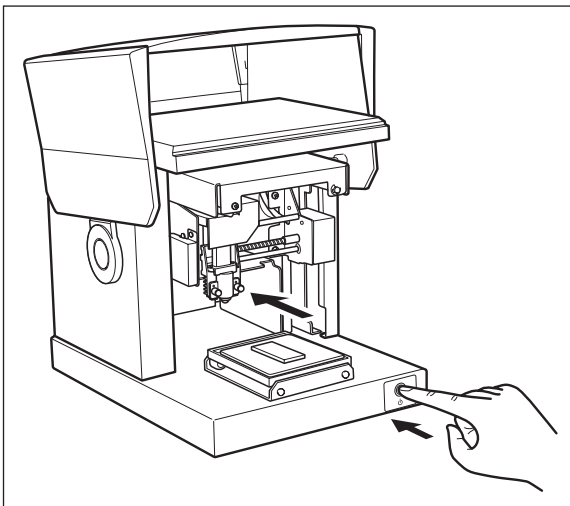

Press the Power/Movement button.

The head moves to the left rear.

10

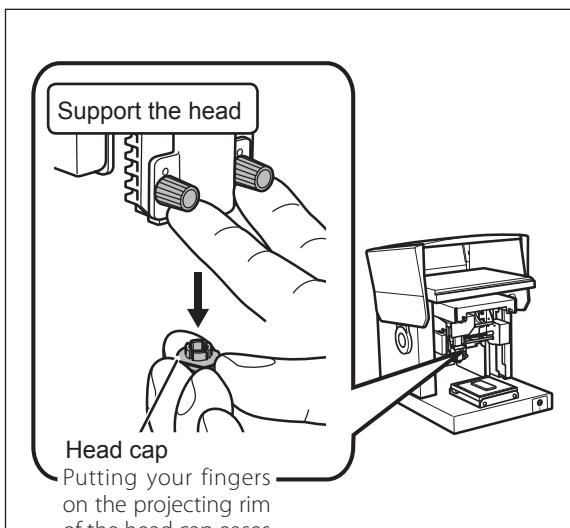

Detach the head cap.

Using the Center Vise

- With the center vise, you secure material in place by clamping it in the vise. You can also vary the orientation and front and back sides of the vise when using it. Use it in a way matched to the size and shape of the material.

☞ P. 33, "Preparing Material to Print"

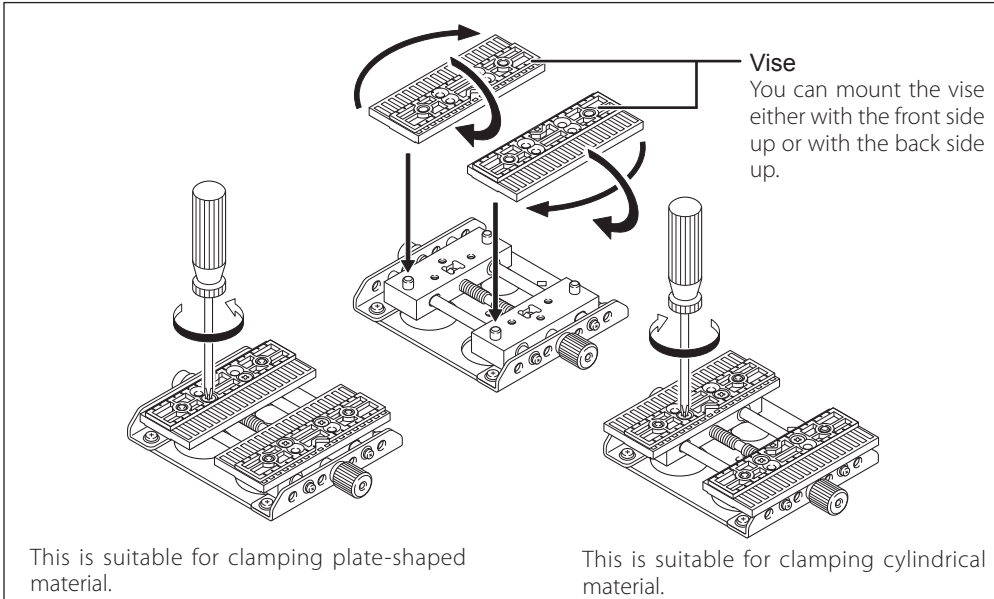

- There are two ways to mount the center vise to the machine, which are vertical mounting and horizontal mounting. Select an appropriate way according to the material size and printing area.

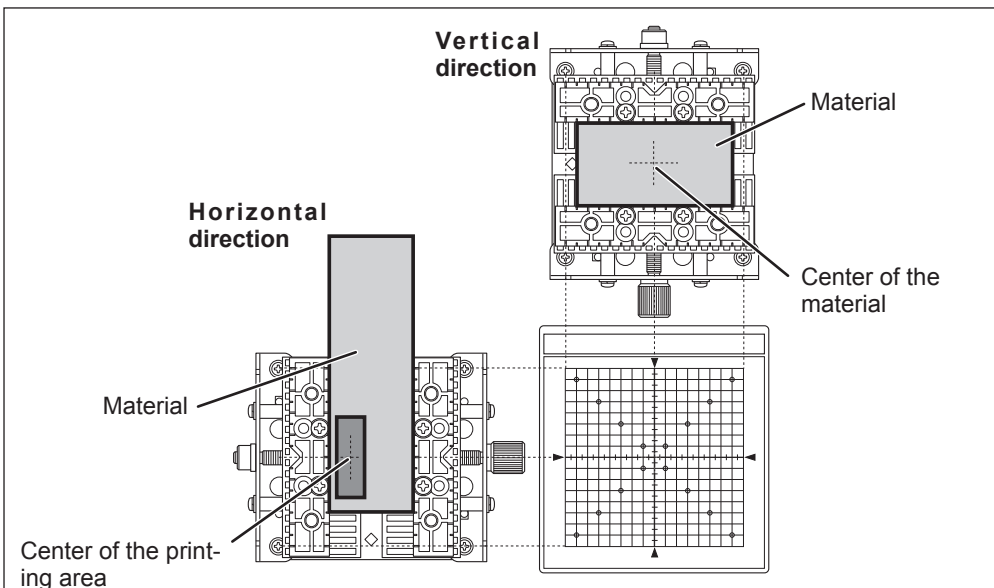

Loading Material Using the Center Vise

Procedure

1 Switch on the power.

⇨ P.30, "Switching On the Power"

2

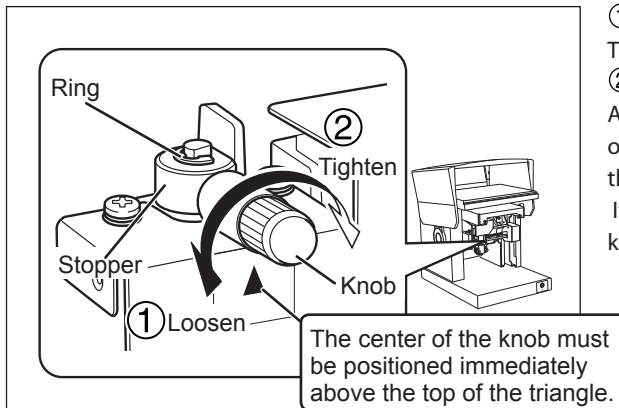

1 Loosen the head's stopper.

The stopper and ring contact each other.

2 Fix the head's stopper.

Align the center of the knob with the top of the triangle right below and then secure the stopper.

If you printing as the stopper is loose, the knob might come off due to vibration.

3

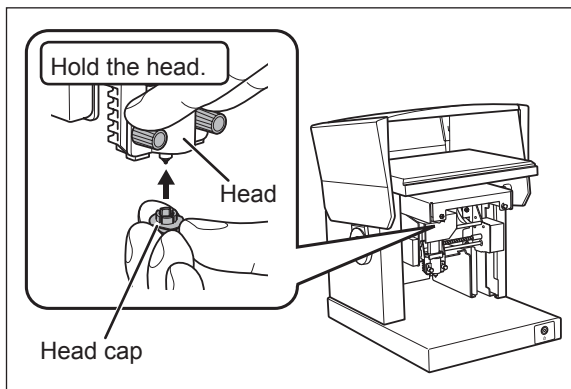

Attach a head cap to the tip of head.

Mount the head as lightly holding it as shown in the figure. The head cap is attached correctly when its tab clicks.

4

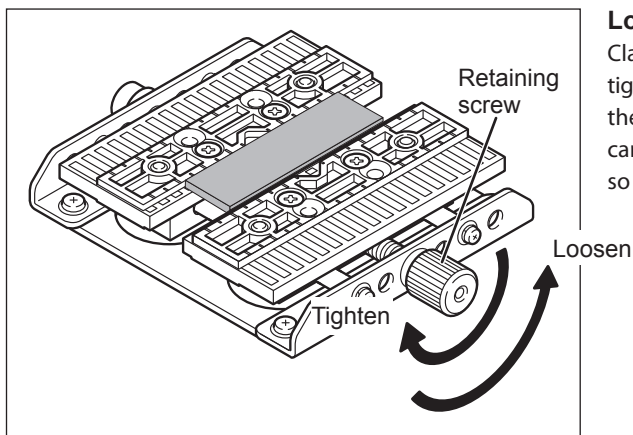

Load the material.

Clamp the material in place in the vise, and tighten the retaining screw enough to keep the material from easily coming loose. Be careful not to overtighten, because doing so may damage the material.

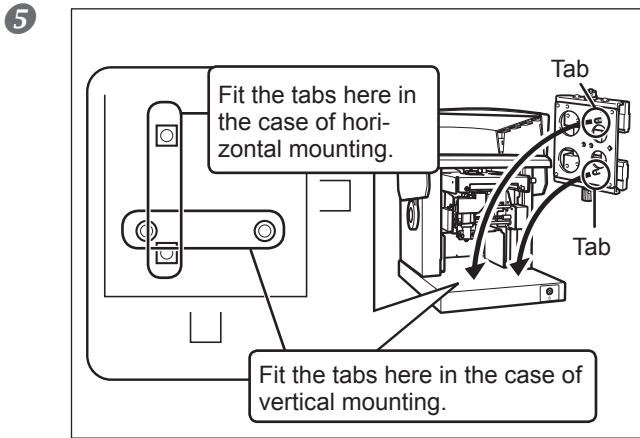

Mount the center vise.

Fit the tabs on the bottom of the center vise into the holes in the table on the unit. If the material tilts, place a support in order to keep the material horizontal.

If you're performing printing with head cap used, this completes loading of the material.

If you're performing printing with no head cap used, then go on to the following steps.

If you're performing printing with head cap

The procedure from this point on is for when you're not using the head cap.

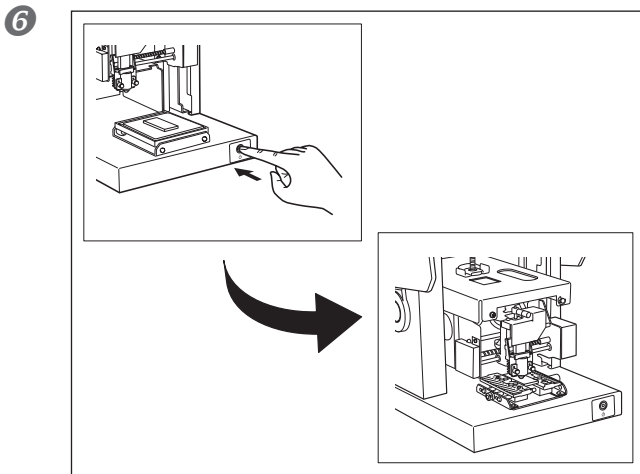

Press the Power/Movement button.

The head moves and stops at the location where the tip of the nose cap touches the surface of the material.

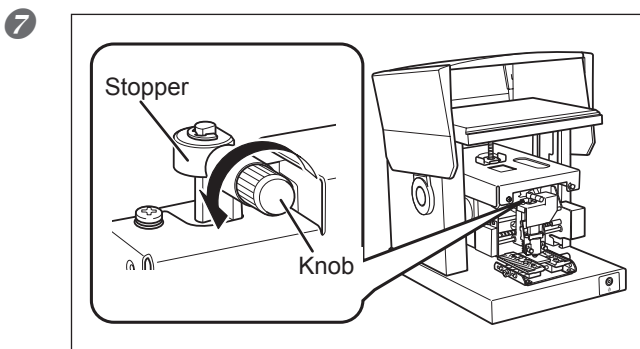

Loosen the knob.

Rotate the knob counterclockwise once. Then you can move the stopper.

8

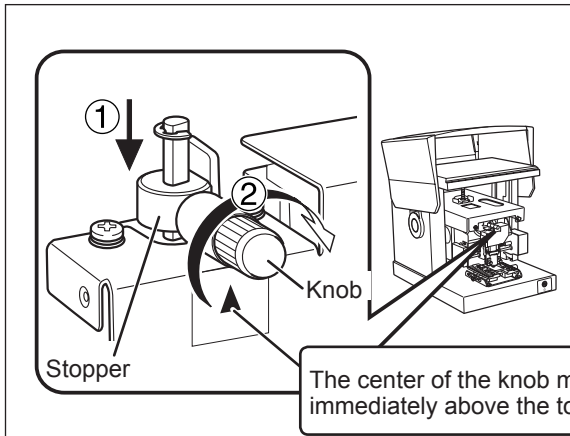

① Move the knob to the lowest position as shown in the figure.

② Tighten the knob.

Align the center of the knob with the top of the triangle right below and then secure the stopper.

9

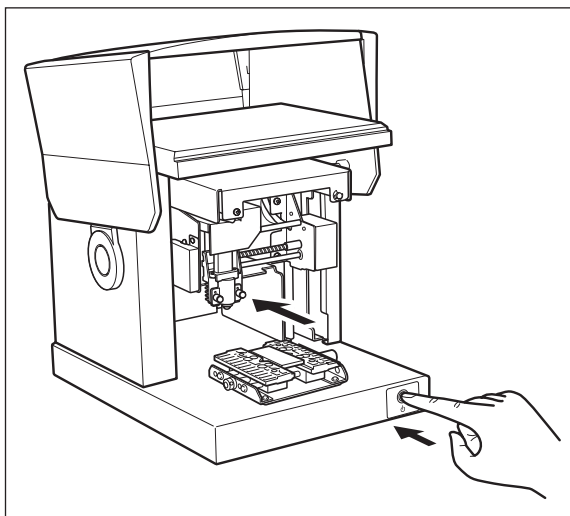

Press the Power/Movement button.

The head moves to the left rear.

10

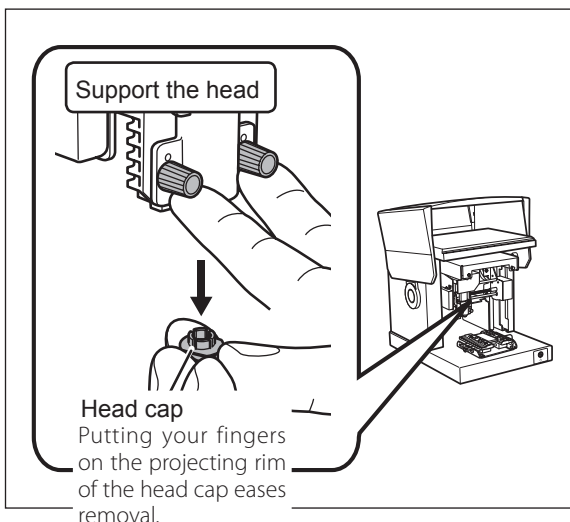

Detach the head cap.

3-3 Preparing Print Data (METAZASudio)

Starting METAZASudio

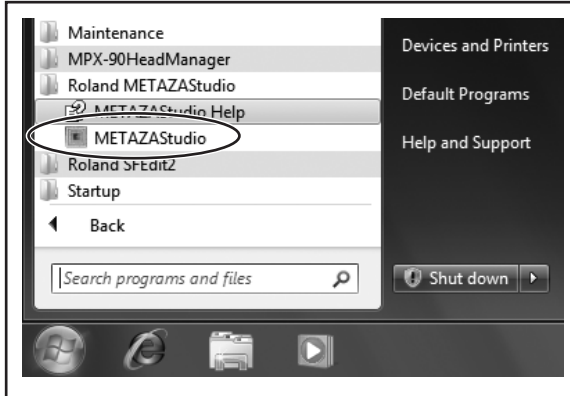

From the [Start] menu, click [All Programs] (or Program) → [Roland METAZASudio] → [METAZASudio].

METAZASudio starts.

☞ P. 45, "METAZASudio Screen"

METAZASudio Screen

Menu Bar
Runs the various commands for METAZASudio.
☞ METAZASudio online help ("Commands")

Toolbar
The toolbar is provided with buttons for running METAZASudio commands such as [Material] and [Open].
☞ METAZASudio online help ("Commands" > "Toolbar buttons")

Table
The unit's table is shown here. The scale displayed represents the actual scale marks on the table.

Work Area
This is the area in which printing is possible. The workpiece size (printing area) set with the Windows-based driver is shown here.
☞ P. 83, "METAZA Driver settings"

Grid
This is a grid of lines displayed in the work area. It serves as a guide for positioning images and text.

Centerline
This indicates the vertical center location of the window.

Margin
This is a blank area where no printing is performed that lies inside the edges of the work area. It is set at 1 millimeter by default. You can change the size of the margin by going to the [File] menu and selecting [Preferences].
☞ P. 46, "Step1 : Determine the shape and size of material," p. 77, "Step1 : Decide on the Printing Area (Workpiece Size)"

Present Cursor Position
This indicates the present location of the cursor. The position at the center of the window (where the two centerlines intersect) is (0, 0).

Centerline
This indicates the horizontal center location of the window.

View Scaling Factor
This displays the present scaling factor for the screen view. Clicking the right mouse button over this displays a menu that lets you change the view scaling factor.

Page Feed Bar
When you have entered data into a variable field, use this to specify the page (record) that is displayed on the screen.
☞ METAZASudio online help ("Hints and Tips" > "Performing Variable Printing")

Grid Pitch
This displays the pitch (spacing) of the grid lines. Clicking the right mouse button over this displays menu items related to the appearance of the grid.

Status Bar

This shows the present location of the cursor, information about the shape, the grid, and the view magnification. Moving the pointer to a toolbar button or pointing to a menu command makes a brief explanation of the button or command appear at the left edge.

Note : Shape Information

This appears when you click an on-screen object (image, text, or shape). The center position and size of the present shape are displayed, as shown in the figure below.

Center: 0.2, 1.3 mm Size: 16.4, 15.3 mm

Step1 : Determine the shape and size of material.

This section explains the shape and size of material to be determined by METAZASudio when using the plate as explained below. METAZASudio has a number of different types of material preregistered. Use the material with the "tag" name, which has the same shape as the plate used

⇨ P. 33, "Preparing Material to Print"

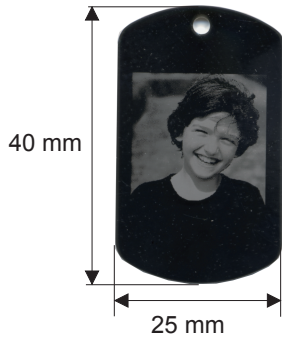

➤ When you want to print on cylindrical material and other curved surfaces, see the section given below.

⇨ P. 77, "4-5 Printing on a Curved Surface"

➤ If you want to register new material, see the section given below.

⇨ P. 82, "4-6 Register New Material"

Procedure

1

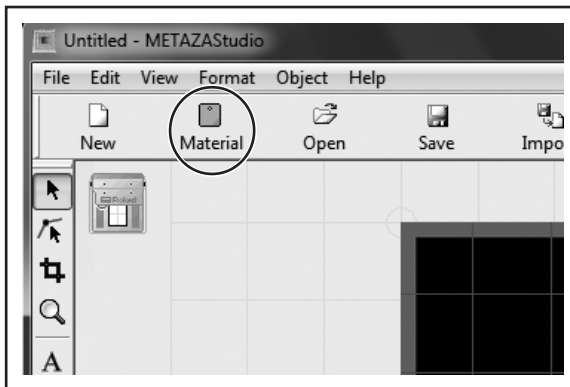

Click .

The [Material] window appears.

2

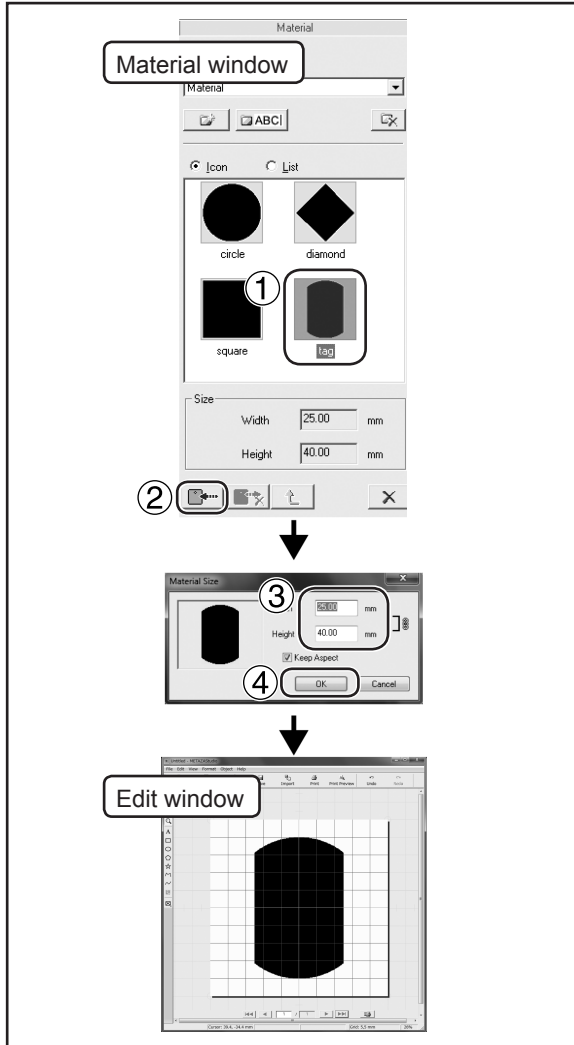

① Click the icon with the “tag” name.

② Click .

The [Material Size] dialog box appears.

③ Enter the values for the size of the material.

④ Click [OK].

The material you selected appears in the Edit window. The portion displayed as the material becomes the printing area without change.

3

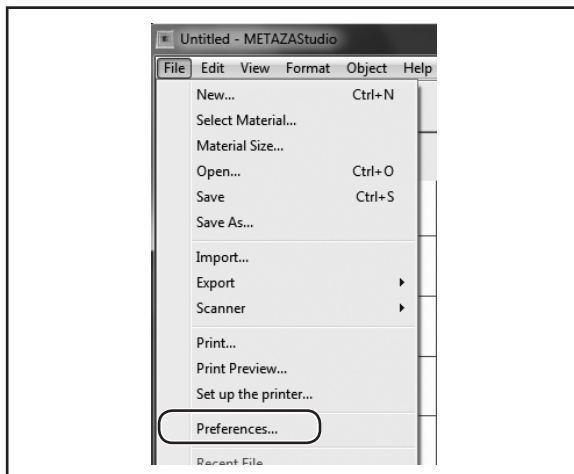

Click [File] → [Preference].

The [Preferences] dialog box appears.

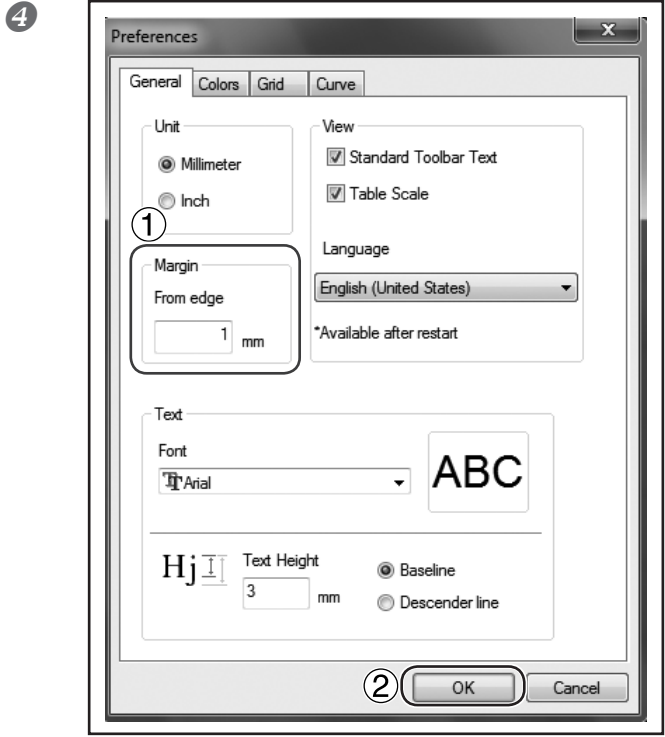

- ① Set “Margin” to “1 mm.”
- ② Click [OK].

! Important
For printing on a flat plate, make the margin at least one millimeter. Otherwise the marking pin may strike and damage the edge of the material.

Step2 : Import the Image

Here you import an image (such as photograph or drawing) for printing.

Data formats supported by METAZASStudio

- Files in JPEG format
- Files in BMP (bitmap) format
- Files in AI or EPS format created by Illustrator version 7 or 8
- Files in AI or EPS format exported by CorelDRAW version 7 or 8

Note : Illustrator and CorelDRAW files are subject to a number of limitations. For details, see the online help for METAZASStudio.

☞ METAZASStudio online help ("Hints and Tips" > "Reusing Existing Data")

Procedure

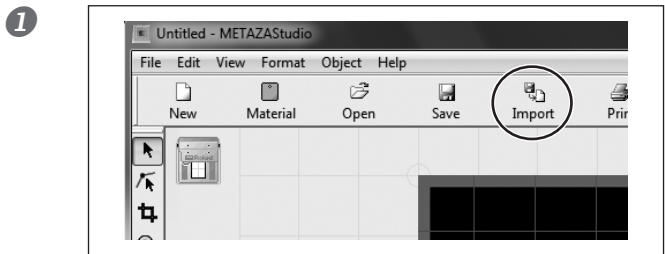

- ① Click .
- The [Import] dialog box appears.

2

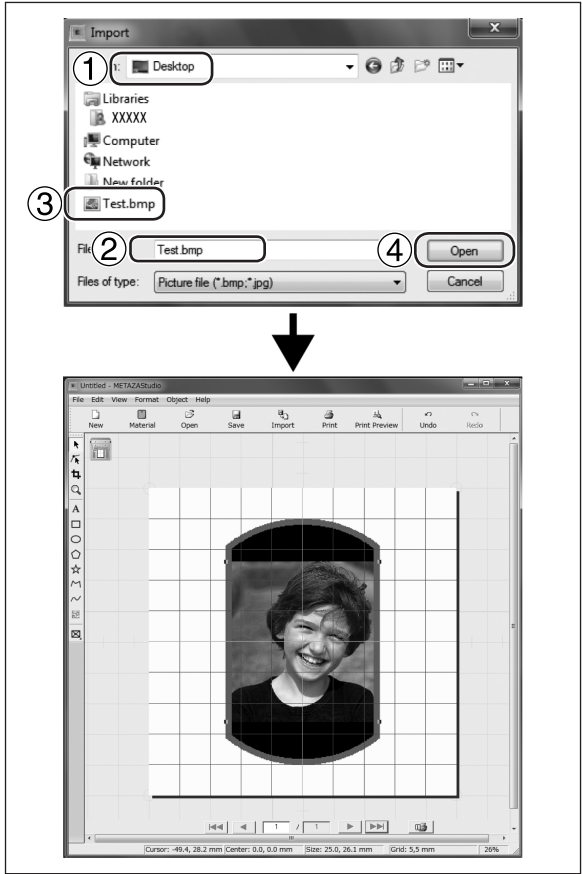

- ① At [Look in], select the location of the file.
- ② At [Files of type], select either [Picture file] or [Adobe Illustrator file].
- ③ Select the file you want.
- ④ Click [Open].

The specified image is imported and displayed with the margins you set.

You can vary the arrangement of the placed image, such as by changing its size or orientation or by adding borders around it.

☞ P. 58, "4-1 Tips and Tricks for Image Layout"

! Important

If the material has holes, take care to ensure that the image is not laid out over the holes. If you include the holes in the printing area, the marking pin might hit the edge of the material, damaging it.

☞ P. 59, "Adjusting the Location, Size, or Angle of an Image"

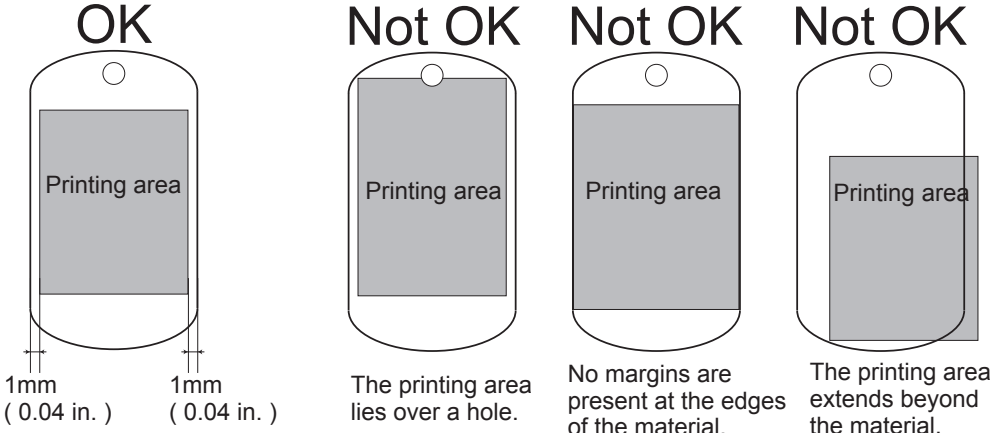

Step3 : Enter the Text

Here you type in the text to print.

Procedure

1

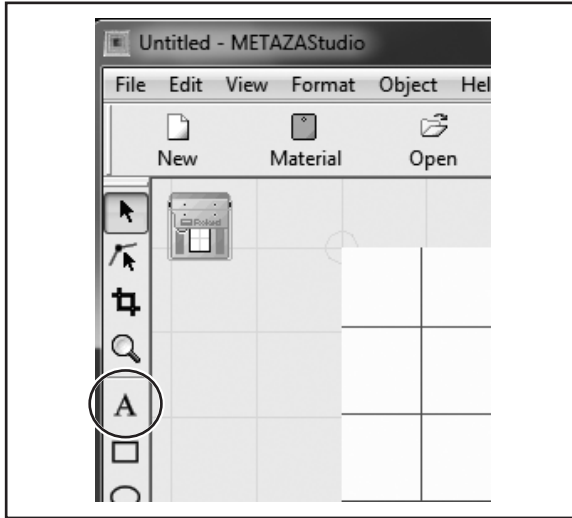

Click .

2

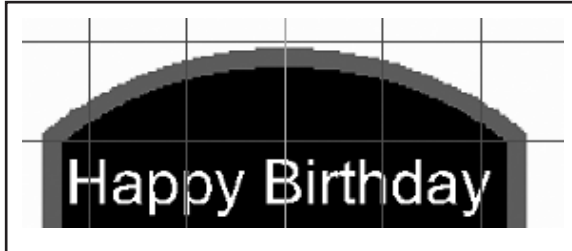

1 Click on the printing area.

2 Type in the text.

You can change the size and orientation of the typed text and fill it.

☞ P. 64, "4-2 Tips and Tricks for Text Layout"

Step4 : Save Printing Data

Save the printing data in a file.

Procedure

1

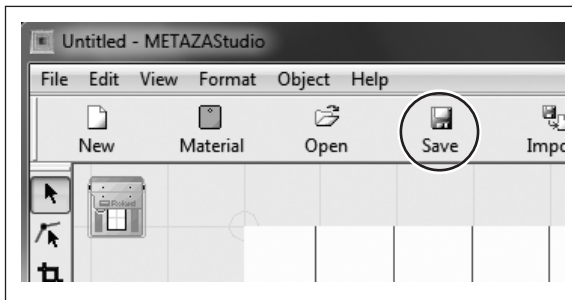

Click .

The [Save As] dialog box appears.

2



① For [Save in], specify where to save the file.

② Type in a file name.

③ Click [Save].

3-4 Starting and Stopping Printing

Starting Printing

Important!

Never attempt printing in any of the following situations.

- When no material is loaded
- When the head is not set at an appropriate position based on the surface height of the material in the case that you do not use the head cap.

☞ P. 36, "Loading Material Using the Adhesive Sheet," p. 41, "Loading Material Using the Center Vise"

Procedure

1

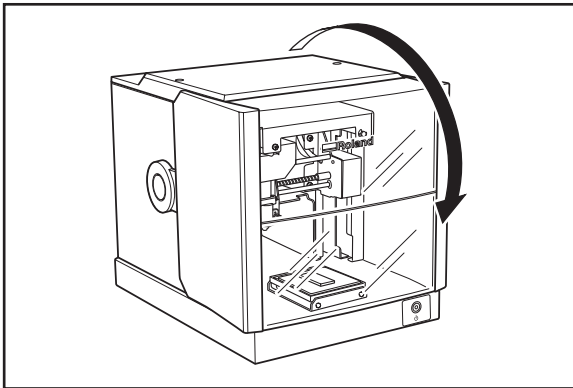

Close the cover.

2

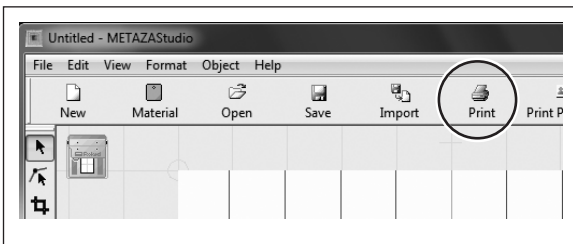

Click 

The [Print] dialog box appears.

3

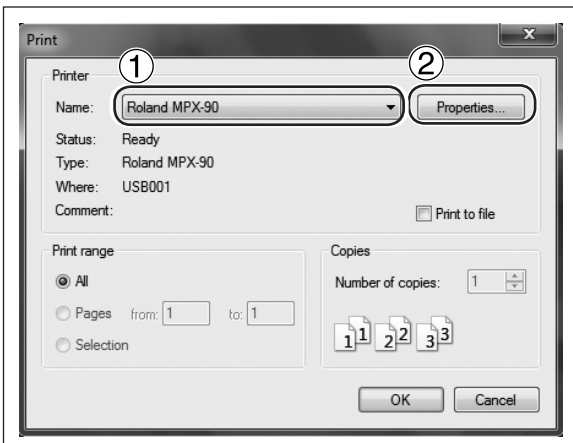

① Make sure [Roland MPX-90] is chosen as the printer name.

② Click [Properties].

4

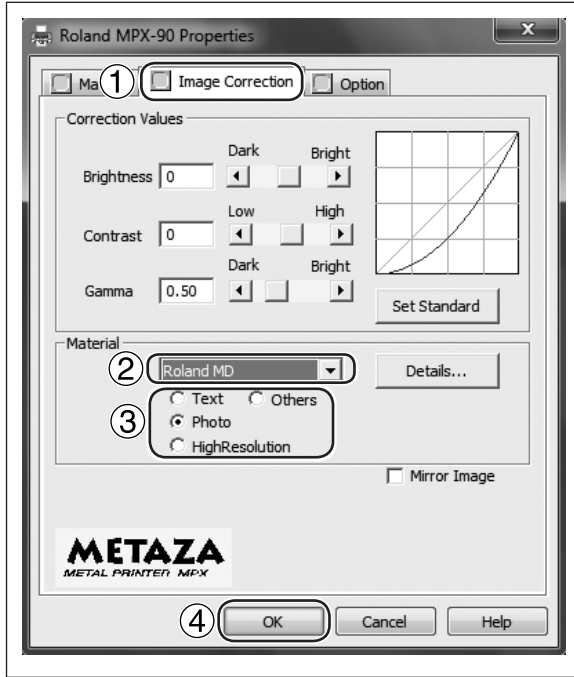

1 Click the [Image Correction] tab.

2 Select [Material].

Select either the composition or the product code of the material.

You can adjust and register the striking force.

☞ P. 92, "Registering a Composition and Adjusting the Striking Force"

3 Select Print mode.

☞ P. 92, "Registering a Composition and Adjusting the Striking Force," METAZA Driver online help ([Correction] tab)

4 Click [OK].

5

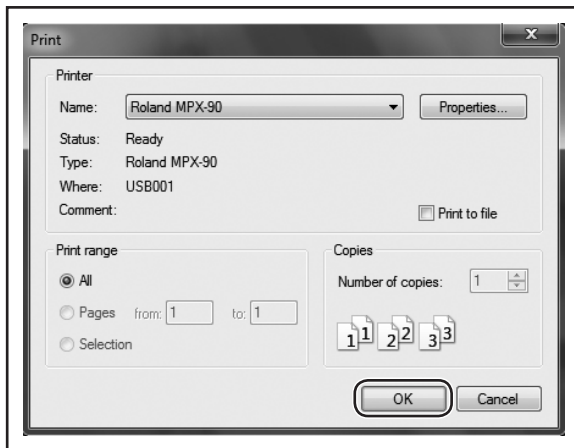

Click [OK].

The printing data is sent to the machine and printing starts.

6

After printing has finished, open the cover and detach the material.

Do not open the cover until the operation is completely stopped.

If the material is difficult to detach when using the adhesive sheet, inserting a thin, flat object (such as a piece of stiff paper or cardboard) between the adhesive sheet and the material may make it easier to dislodge.

Stopping Printing Operations

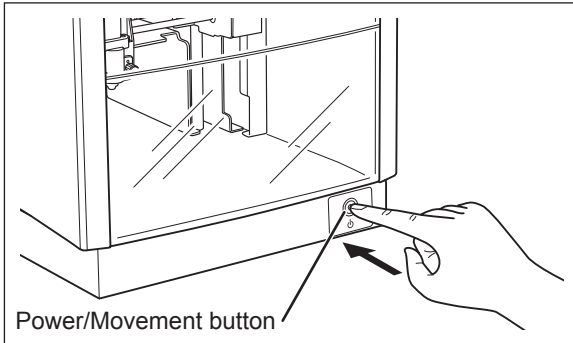

Hold down the Power/Movement button for one second or longer.

The light slowly blinks while the transmitted print data is being deleted. The light goes dark and the power is switched off.

You can delete the print data with the following method.

Procedure

- 1 Windows 7**
From [Start] menu, click [Control Panel] → [Hardware and Sound] → [Devices and Printers].
Windows Vista
From [Start] menu, click [Control Panel] → [Hardware and Sound] → [Printers].
Windows XP
From [Start] menu, click [Control Panel] → [Printers and Other Hardware] → [Printers and Faxes].



Double-click the [Roland MPX-90] icon.

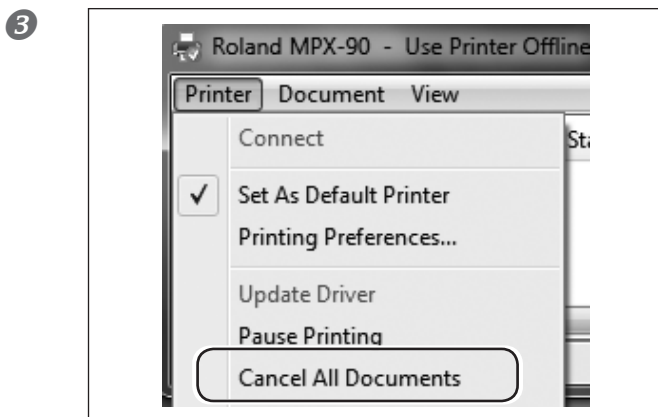

At the [Printer] menu, click [Cancel All Documents] (or [Purge Print Documents]).

4

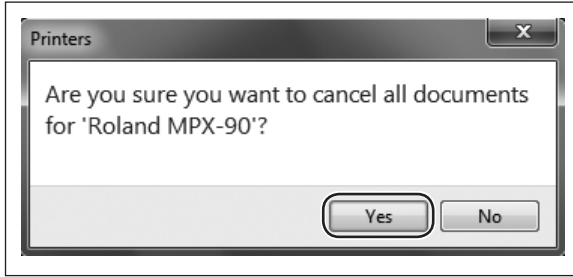

If the message shown in the figure appears, click "Yes."

Chapter 4

More Advanced Operations

4-1 Tips and Tricks for Image Layout.....	58
Keeping Only the Required Portion of an Image (Trimming)	58
Adjusting the Location, Size, or Angle of an Image.....	59
Enclosing an Image in a Frame.....	62
4-2 Tips and Tricks for Text Layout	64
Adjusting the Location, Size, or Angle of a Text	64
Arranging a Text to a Fan Layout	66
Laying Out Text along a Shape	67
Filling Text.....	68
4-3 Creating and Editing Line Text.....	70
SFEdit2 window.....	70
Creating a Stroke Character Font.....	71
Changing Input Characters into Stroke Characters.....	73
Editing Stroke character	74
4-4 Checking and Adjusting Finished Result of an Image	75
Checking the Finished Results in the Preview Window.....	75
Adjusting the Finished Result in the Preview Window.....	76
4-5 Printing on a Curved Surface.....	77
Step1 : Decide on the Printing Area (Workpiece Size)	77
Step2 : Make horizontal writing on portrait material.	80
4-6 Register New Material	82
How to Register Wide Variety of Material	82
4-7 METAZA Driver Settings	83
Keeping the settings of METAZA Driver	83
4-8 About Dr. Engrave.....	84
What is Dr. Engrave?.....	84
Points to note when using Dr. Engrave	84
4-9 More Advanced Other Operations	85
More Advanced Other Operations You Can Accomplish with METAZAStudio.....	85

4-1 Tips and Tricks for Image Layout

Keeping Only the Required Portion of an Image (Trimming)

METAZAStudio can cut an original image to remove unneeded areas and keep just the required portion. This operation is called “trimming.”

In this example, you use the printing data created from page 46 to 49.

Procedure

1

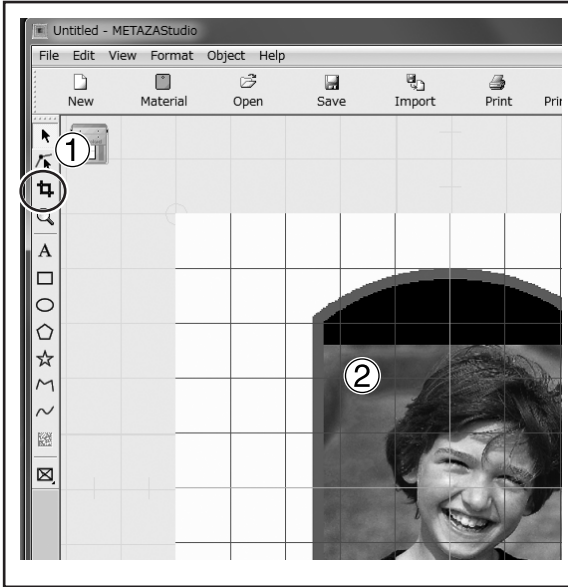

1 Click .

2 Click the image.

Eight trimming bars appear around the image.

2



Trimming

Drag the trimming bar to trim the area you want to keep.

Trimming bar

Adjusting the Location, Size, or Angle of an Image

METAZAStudio can change the location, size, and angle of a placed image to achieve the layout you want. In this example, you use the printing data created at page 58, "Keeping Only the Required Portion of an Image (Trimming)."

Procedure

1

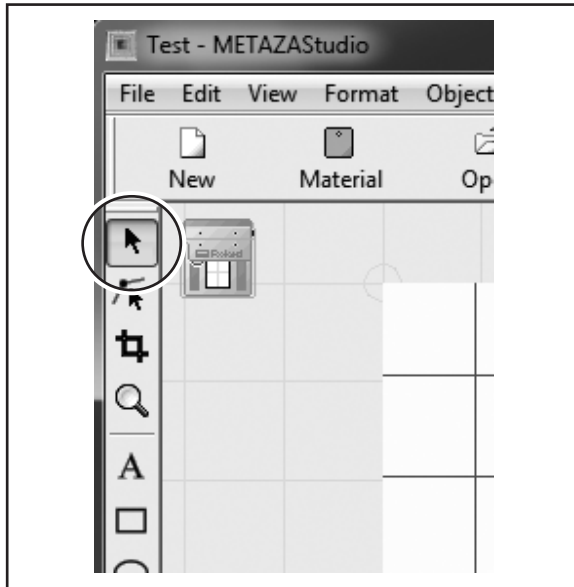

Click .

2



① **Click the image.**

Handles (■) appear at the four corners of the image.

② **Drag the image to adjust its location.**

3

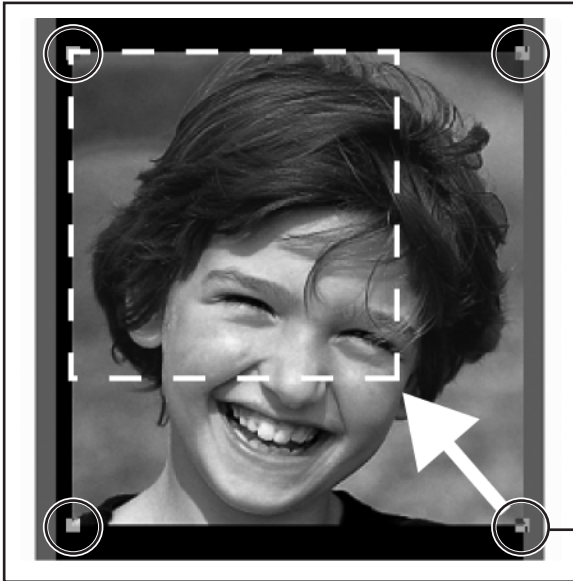

Drag the handles at the four corners of the image to adjust the size.

Handles

4

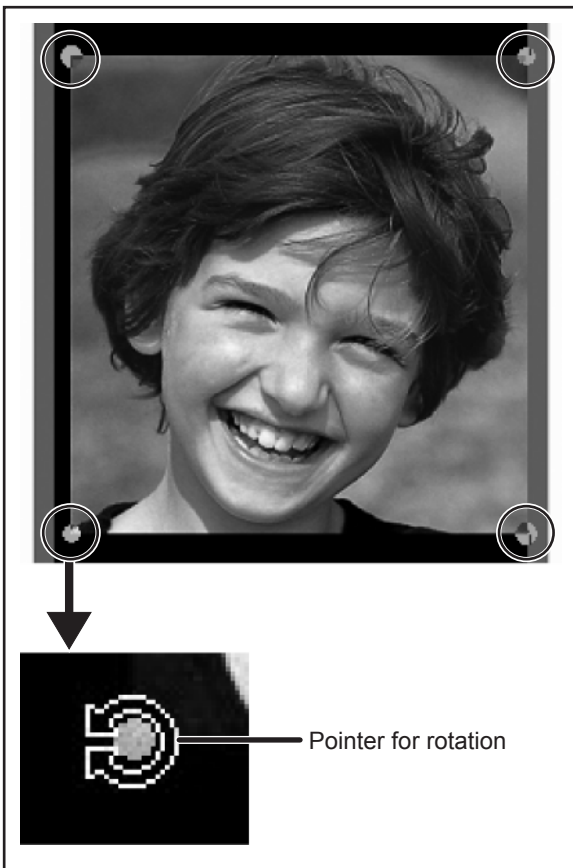

① With the handles present at the four corners of the image, click the image a second time.

The shape of the handles at the four corners changes to (●).

② Line up the pointer with a handle.

The shape changes to a pointer for rotation.

Pointer for rotation

5



Drag to adjust the angle of the image.

**Point**

- Holding down the keyboard's SHIFT key as you drag makes the angle change by 45 degrees at a time. Using this method can be convenient at times such as when you want to perform rotation by precisely 90 degrees.
- Trimming cannot be performed for an image whose angle has been changed. To perform trimming, first return the image to its original angle.

Enclosing an Image in a Frame

You can change the arrangement of printing data by placing a frame around an image. You use frames registered in what's called METAZAStudio's "library." The library contains a number of preregistered frames, and you can also register new ones.

⇒ METAZAStudio online help ("Hint and Tips" > "Making Use of Library")

In this example, you add a frame to the printing data created at page 55, "Adjusting the Location, Size, or Angle of an Image."

Procedure

1

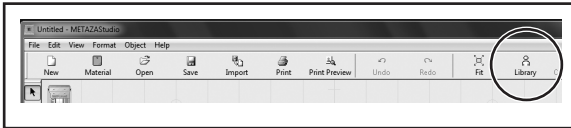

Click .

The [Library] window appears.

2

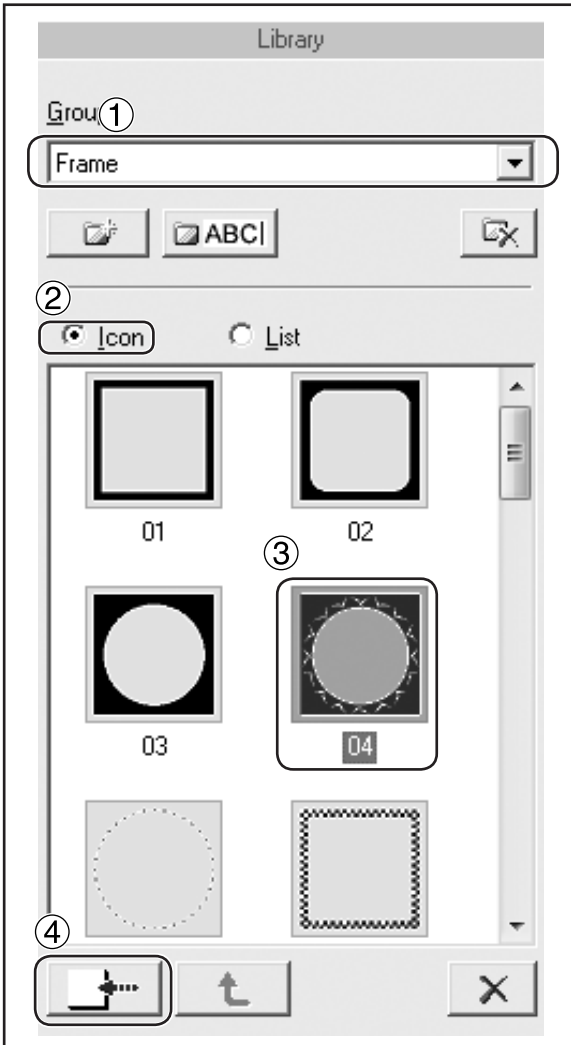

1 From [Group], select [Frame].

2 Select [Icon].

3 Click the [04] frame.

4 Click .

A frame is inserted into the window.

3

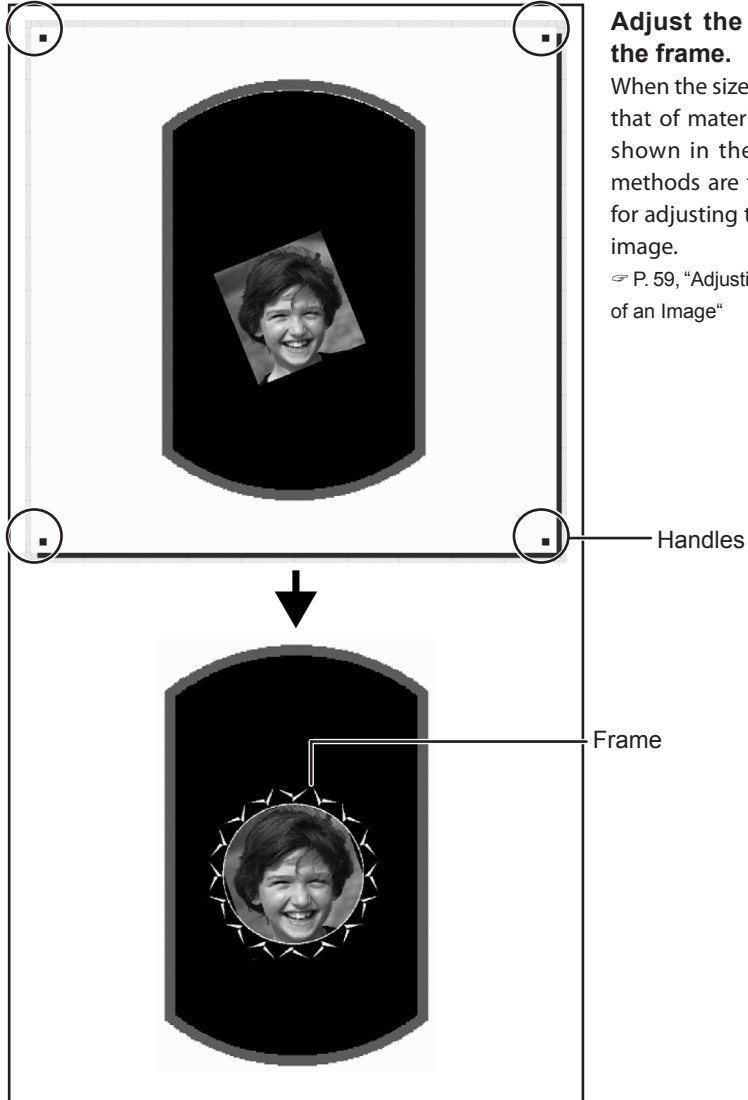
**Adjust the size and location of the frame.**

When the size of the frame is larger than that of material, the result becomes as shown in the figure. The adjustment methods are the same as the methods for adjusting the location and size of an image.

☞ P. 59, "Adjusting the Location, Size, or Angle of an Image"

4-2 Tips and Tricks for Text Layout

Adjusting the Location, Size, or Angle of a Text

You can change the location, size, and angle of a placed text same as image.

Procedure

1



1 Arrange the text horizontally.

☞ P. 50, "Step3 : Enter the Text"

2 Click .

3 Click the laid-out text.

Eight handles appear around the text.

4 Drag the text to adjust its location.

2



Drag the handles to adjust the size.

3

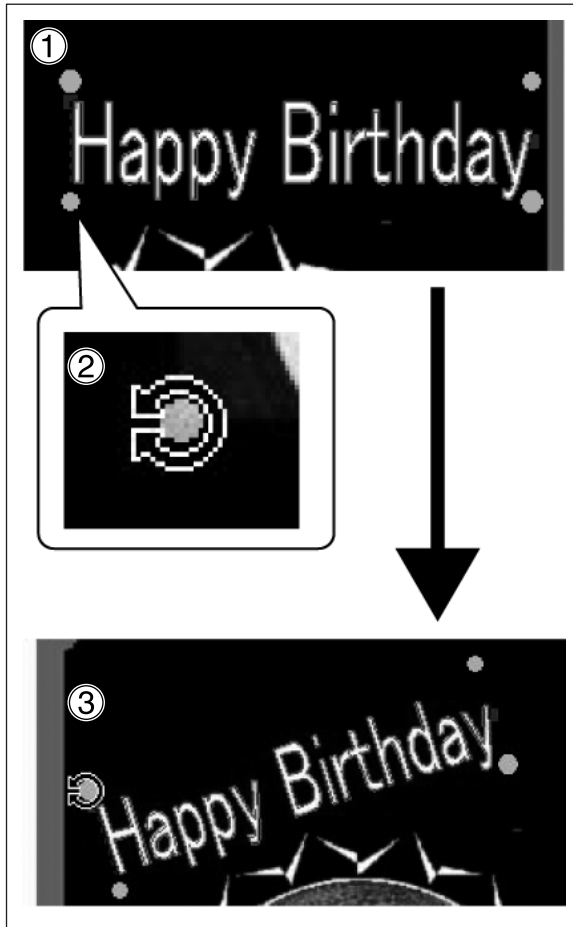

① Click on the text and hold until the shape of the handles at the 4 corners changes to [•].

② Line up the pointer with a handle.

The shape changes to a pointer for rotation.

③ Drag to change the angle of the text.



Point

Holding down the keyboard's SHIFT key as you drag makes the angle change by 45 degrees at a time. Using this method can be convenient at times such as when you want to perform rotation by precisely 90 degrees.

Arranging a Text to a Fan Layout

You can arrange a text to a fan layout.

Procedure

1

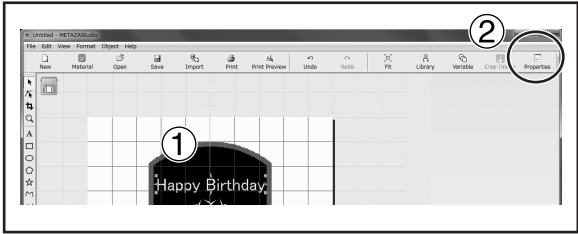

1 Enter text.

☞ P. 50, "Step3 : Enter the Text"

2 Click .

The [Properties] dialog box appears.

2

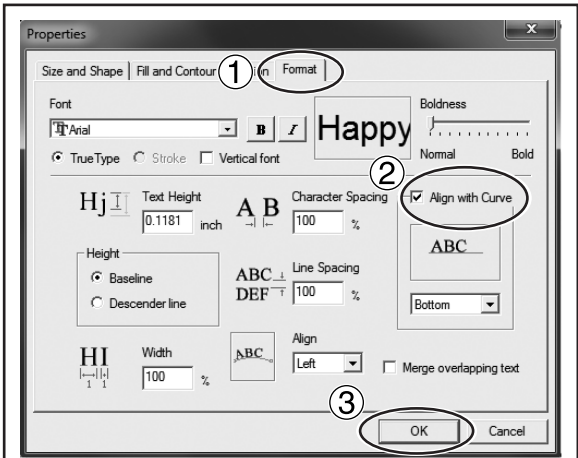

1 Click the Format tab.

2 Select the [Align with Curve] check box.

3 Click [OK].

The layout of the text changes to a fan shape.

Laying Out Text along a Shape

Here you lay out text along a shape you have made using the drawing tools.

Procedure

1

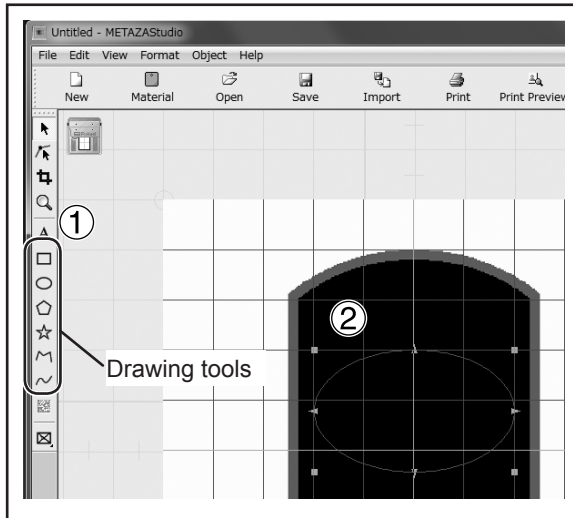

① Click a drawing tool.

In this example you use .

② In the editing window, create a shape on the material.

☞ METAZAStudio online help (“Commands” > “Toolbar buttons”)

2

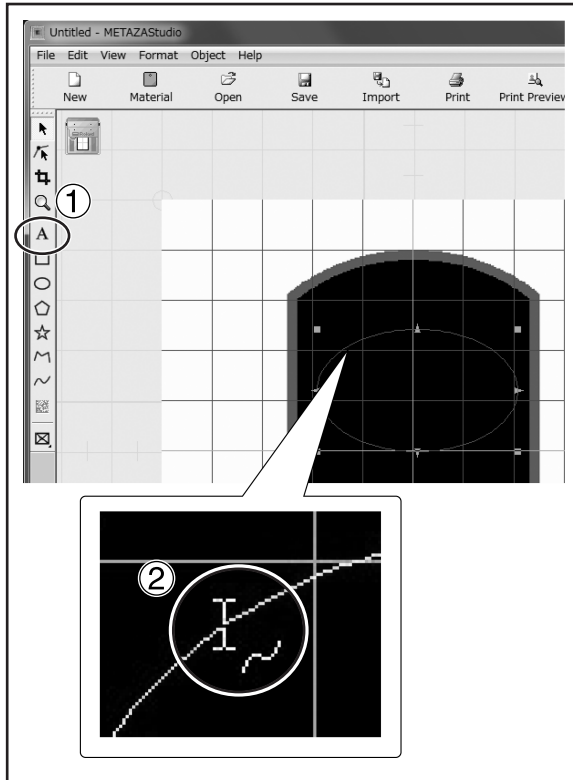

① Click **A**.

② Position the pointer near the outline of the shape you created, and when appears under the pointer, then click .

3

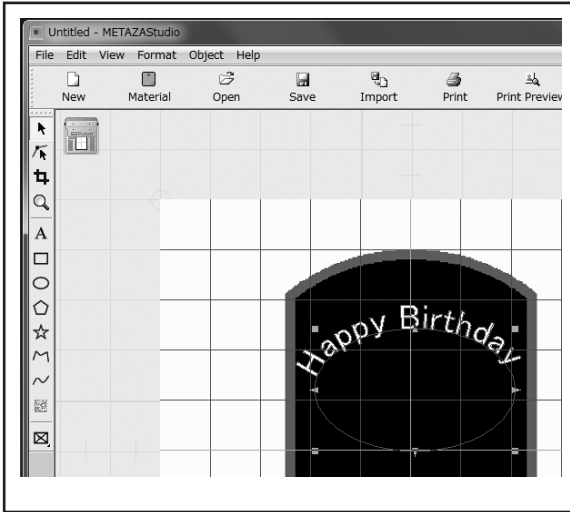

Enter text.

☞ P. 50, "Step3 : Enter the Text"
The text is laid out along the shape.

Important!

Layout on an integrated polyline is not possible.

☞ METAZAStudio online help ("Commands" > "[Object] menu" > "Convert to Polyline," "Integrate Polyline")

Filling Text

There are two ways to fill text: [Fill] and [Island Fill]. Select either way according to your preference.



Fill
Text is filled without space.



Island Fill
You can specify the interval between adjacent filling lines.

Procedure

1

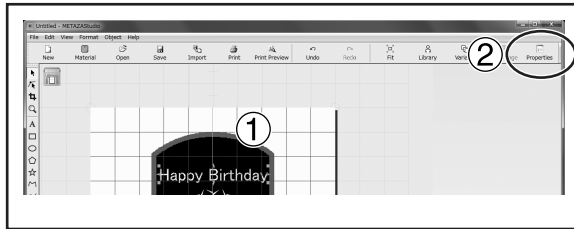

① Enter the text.

☞ P. 50, “Step3 : Enter the Text”

② Click .

The [Properties] dialog box appears.

2

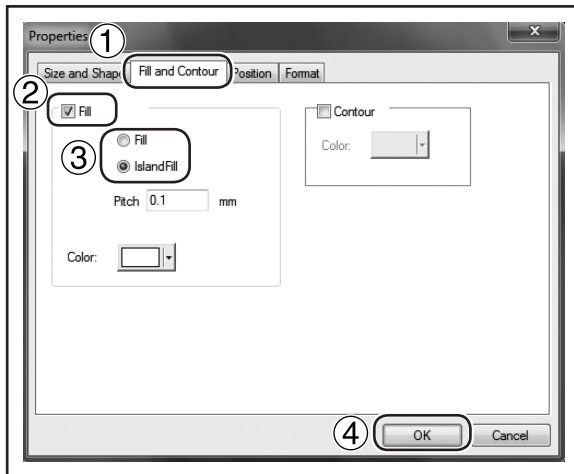

① Click the [Fill and Contour] tab.

② Select the [Fill] check box.

③ Select [Fill] or [Island Fill].

When you select [Island Fill], you need to enter Pitch as well. Pitch is the interval between adjacent filling lines.

④ Click [OK].

The text is filled.

Important!

When you make a print with a lot of lines (Island Fill, etc.) on aluminum material and the like, the unevenness of the material surface is increased, and consequently the head cap becomes worn out faster. Check the state of the head cap regularly so that it can be replaced at an appropriate timing.

☞ P.98, “The Replacement Cycle for the Head Cap”

4-3 Creating and Editing Line Text

SFEdit2 is software to create and edit stroke character fonts. On METAZAStudio, you can use the stroke character fonts that are created and edited by SFEdit2.

SFEdit2 window

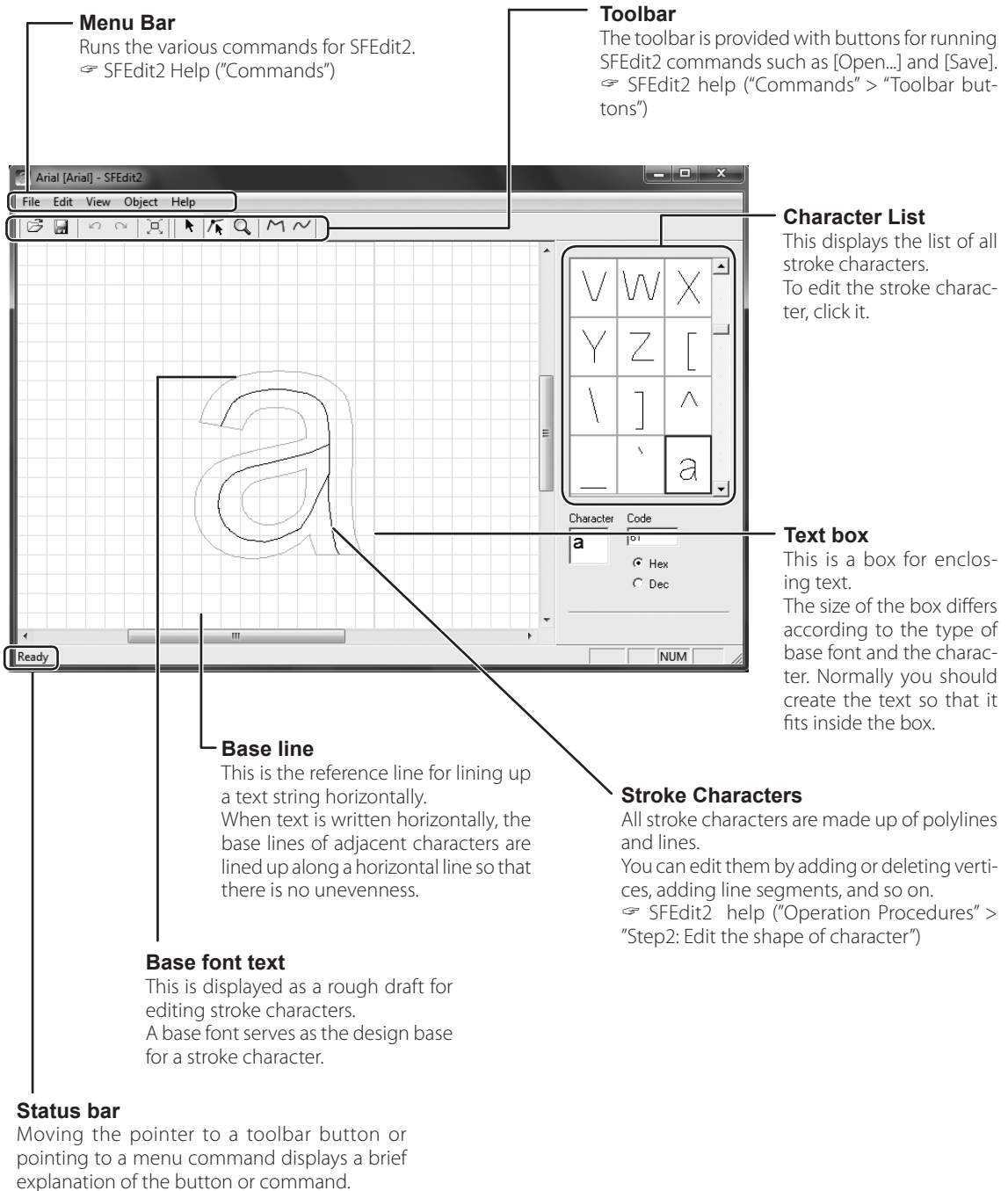

Creating a Stroke Character Font

The method of creating and saving a stroke character font is explained below.

Procedure

1 Starting METAZASstudio.

⇨ P. 44, "Starting METAZASstudio"

2

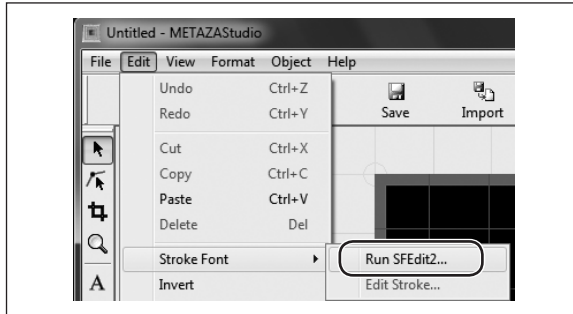

Click [Edit] → [Stroke Font] → [Run SFEdit2...].

SFEdit2 starts.

3

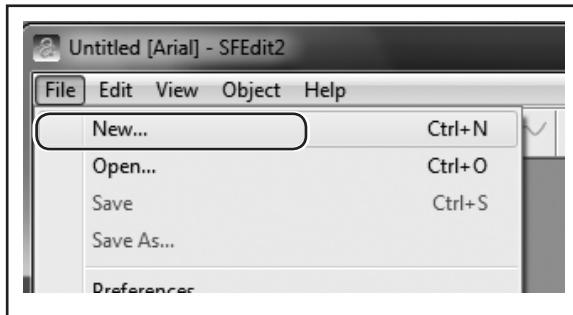

Click [File] → [New...].

[Select Base Font] dialog box appears.

4

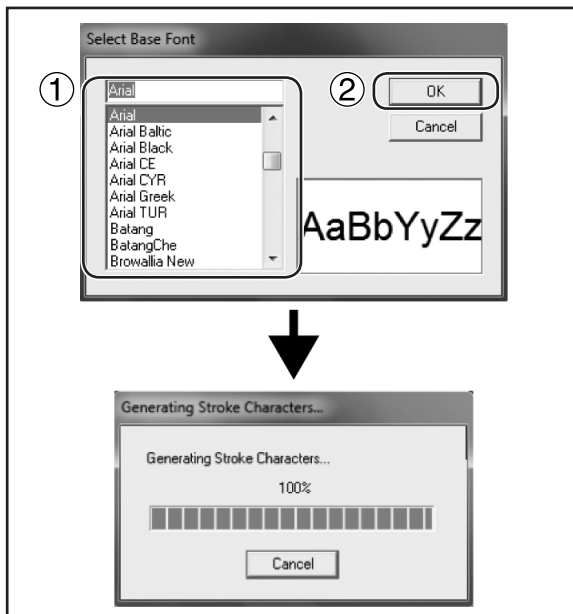

① Select a font which is used as a base of a stroke character font to be created.

② Click [OK].

A stroke character font is automatically created.

5

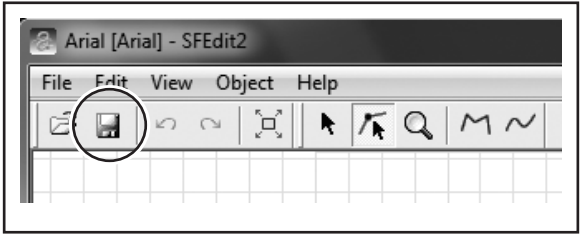

Click .
[Save] dialog box appears.

6

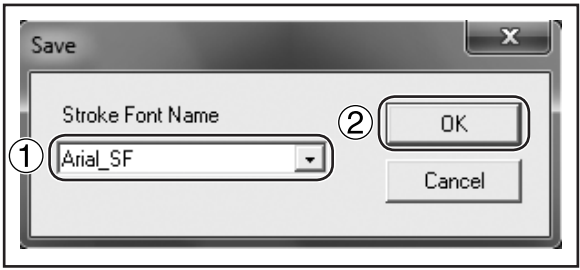

1 Enter a name of the created stroke character font.
2 Click [OK].
The created stroke character font is saved.

7



Click .

Changing Input Characters into Stroke Characters

This section explains the method of changing input characters into stroke characters using a stroke character font.

To use a stroke character font, either of the following operations must be done in advance.

- Create a stroke character font before SFEEdit2 is installed.
- Create a new stroke character font.
 - ⇨ P. 71, “Creating a Stroke Character Font”

Procedure

1 Enter the Text

⇨ P. 50, “Step3 : Enter the Text”

2



Click .

The [Properties] dialog box appears.

3

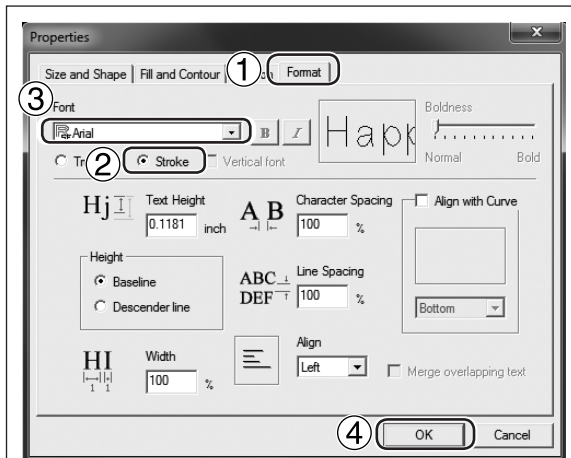

1 Click [Format] tab.

2 Select [Stroke character].

The option of [Font] becomes Stroke character only.

3 Select Stroke character.

4 Click [OK].

Input characters become stroke characters.

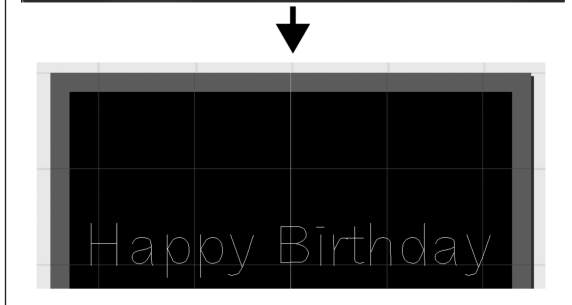

Editing Stroke character

Using SFEdit2, you can edit the shape of a created stroke character. The procedure to edit a stroke character using SFEdit2 is explained below.

Procedure

1 Change an input character to a stroke character.

☞ P. 73, “Changing Input Characters into Stroke Characters”

2



1 Click the stroke character you want to edit.

Eight pointers appear around the stroke character.

2 Click [Edit] → [Stroke Font] → [Edit Stroke...].

SFEdit2 starts.

3

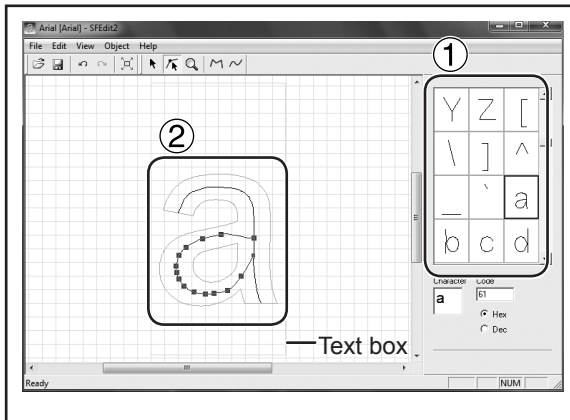

1 From Character List, click stroke character you want to edit.

The stroke character you want to edit is displayed in Text box.

2 Edit the stroke character.

Change the position and shape of the stroke character.

☞ SFEdit2 help (“Editing Polylines”)

4

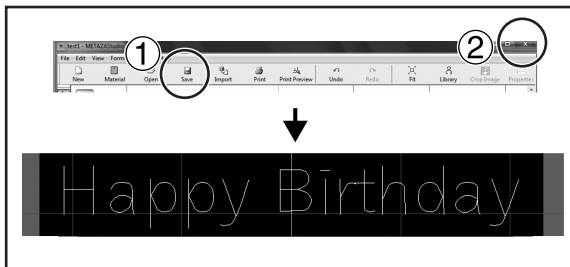

1 Click 

The edit is overwritten to the selected stroke character font.

2 Click 

SFEdit2 is finished.

The edit is reflected to the stroke character.

4-4 Checking and Adjusting Finished Result of an Image

Checking the Finished Results in the Preview Window

Checking the Finished Results in the Preview Window



Click .
Preview window appears.

Preview window

Adjusting the Finished Result in the Preview Window

At the preview window, you can adjust the brightness, contrast, and gamma correction. An image with clearly defined light and dark areas produces attractive printed results.



① Brightness

This adjusts the overall brightness. Making the value too large can destroy the balance, so it may be a good idea to adjust it to the absolute minimum necessary.

② Contrast

This mainly adjusts highlights (the brightest areas) and shadows (the darkest areas). Using this can be effective when you want to achieve a sense of tension with a good balance of light and dark.

③ Gamma

This mainly adjusts the brightness of tones of intermediate brightness between bright and dark areas. Using it is effective in adjusting the overall brightness.

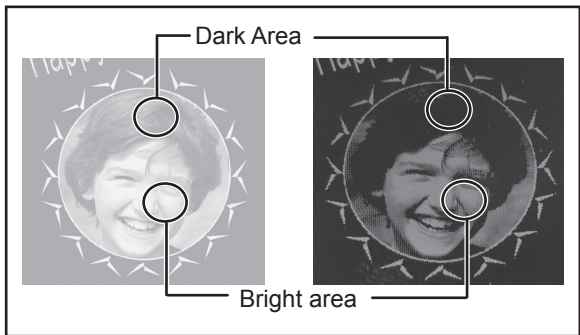

The dark and bright areas are printed as shown in the figure.

Dark-color areas are not struck, and light-color areas are struck forcefully.



Also, the printing results before and after adjustment are as shown below.

4-5 Printing on a Curved Surface

With this machine, using a head cap lets you perform printing on cylinders and other examples of material whose surface height is not uniform. This section describes how to create data, using printing on a cylindrical material like the one shown below as an example.

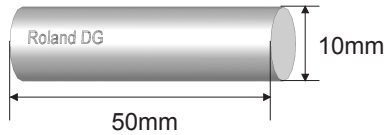

Step1 : Decide on the Printing Area (Workpiece Size)

First, you make the settings for the printing area on the material. In the case of printing on cylindrical material, printing over the entire surface of the material (as on flat material) is not possible. For this reason, the METAZAStudio editing window displays the printing area instead of the material. The printing area is determined by the value of the material's diameter entered at the setting window for the driver. For more information about the conditions of cylindrical material that this machine can print, refer to the page indicated below.

⇨ "Conditions for Material When Printing Curved Surfaces" in "P. 33, "Preparing Material to Print"

Procedure

1

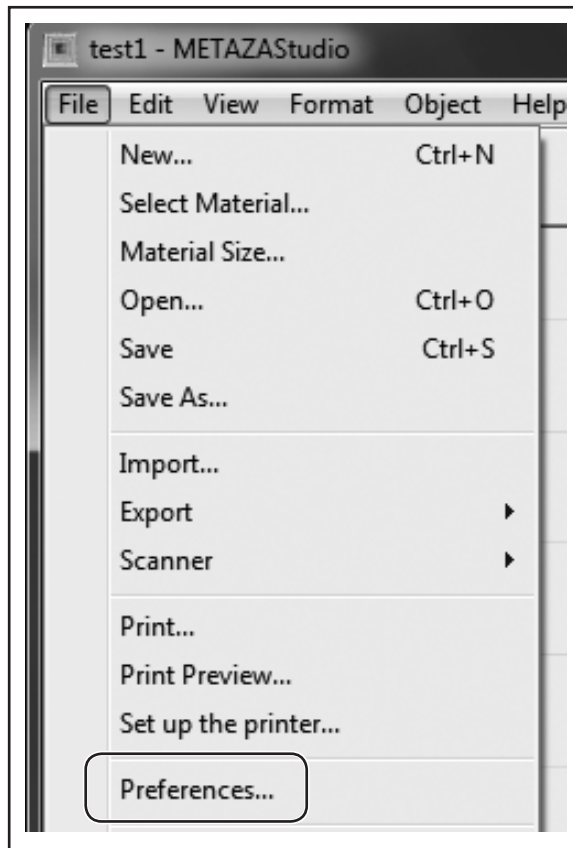

Click [File], then click [Preferences].

The [Preferences] dialog box appears.

2

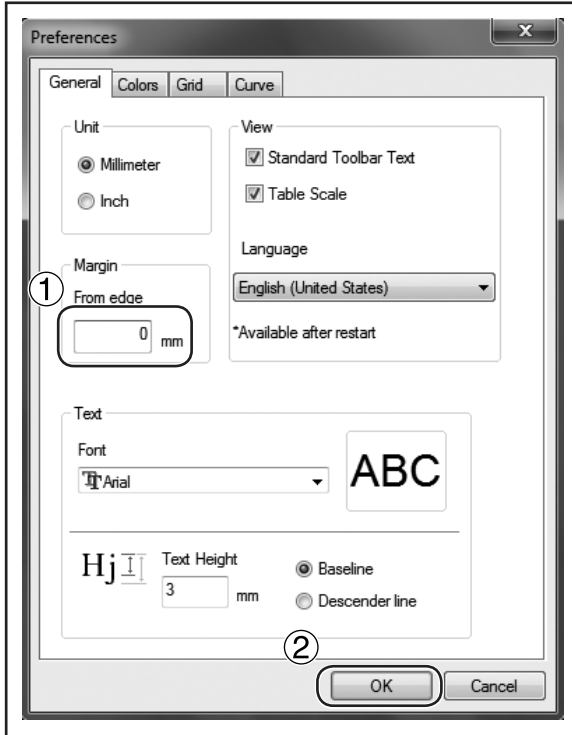

1 Set “Margin” to “0 mm.”



Point

When you’re printing on cylindrical material, set the margins to zero millimeters. When printing on cylindrical material, the makeable area is limited, and so a sufficient printing area must be ensured by making the margins zero millimeters in size.

2 Click [OK].

3

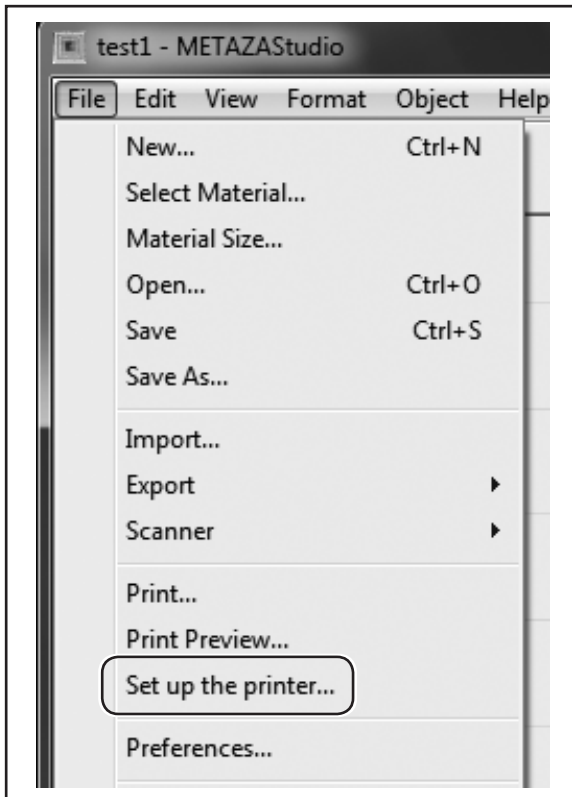

Click [File], then click [Set up the printer].

The [Print Setup] dialog box appears.

4

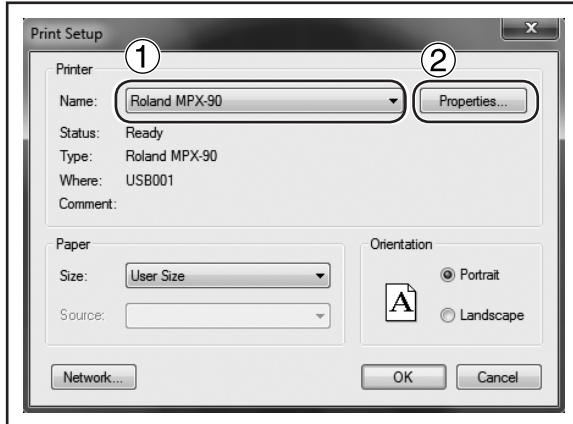

- ① Make sure [Roland MPX-90] is chosen as the printer name.
- ② Click [Properties].

5

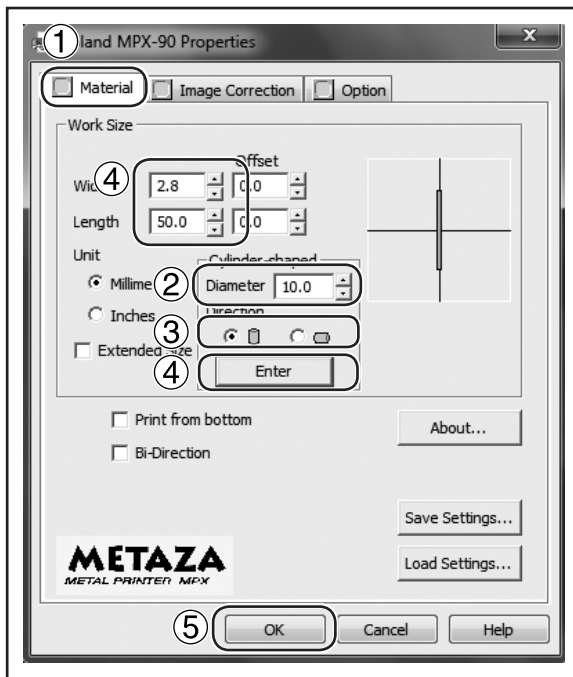

- ① Click the [Material] tab.
 - ② Set [Diameter] to 10 millimeters.
 - ③ Select [Direction].
- Make horizontal writing on portrait material.



- In this example, select  (vertical).
- ④ Click [Enter].
- Under [Work Size], the value for [Width] is set automatically.
For [Length], in this example, make the setting of 50 millimeters.
- ⑤ Click [OK].

6

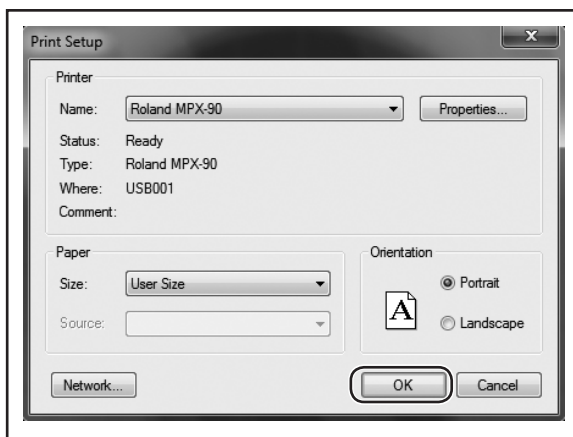

- Click [OK].
- This is the end of the printing area setting.

Step2 : Make horizontal writing on portrait material.

After the printing area is determined, place images and text on the area.

This section explains the method of inputting characters horizontally on portrait material.

Procedure

①

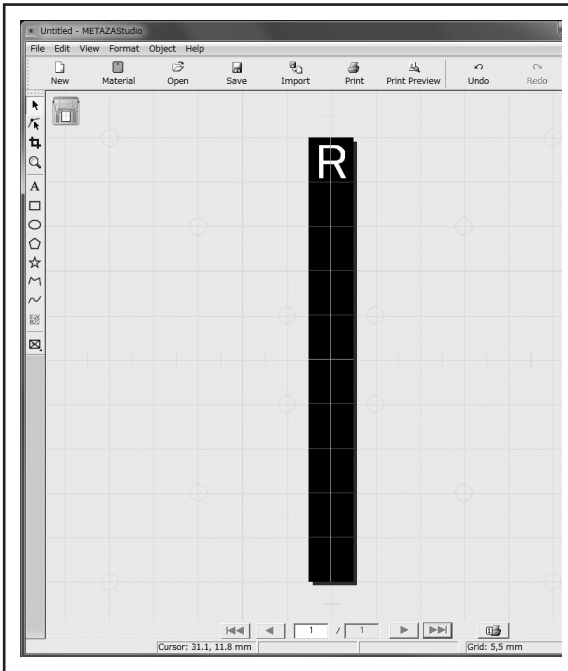

① **Type in the text to print, then adjust how it's laid out.**

☞ P. 50, "Step3 : Enter the Text"

② **Change the text size to any size of your preference.**

It must be fit within the printing area.

☞ P. 64, "Adjusting the Location, Size, or Angle of a Text"

②

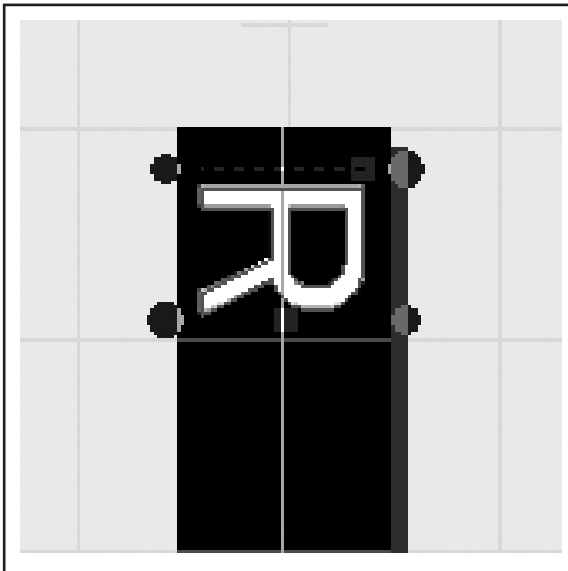

② **Rotate the input character to make it vertical.**

☞ P. 64, "Adjusting the Location, Size, or Angle of a Text"

3

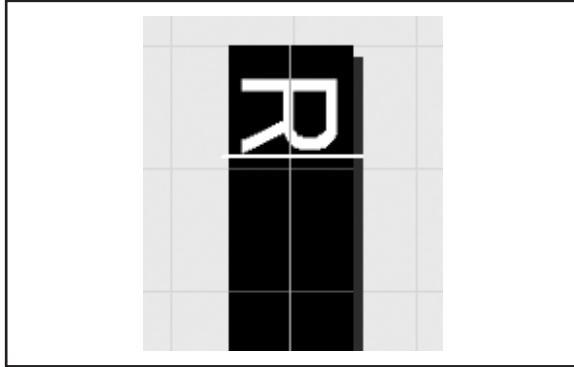

① Click **A**.

② Press the <→> key on the keyboard.

The result becomes as shown in the figure.

4

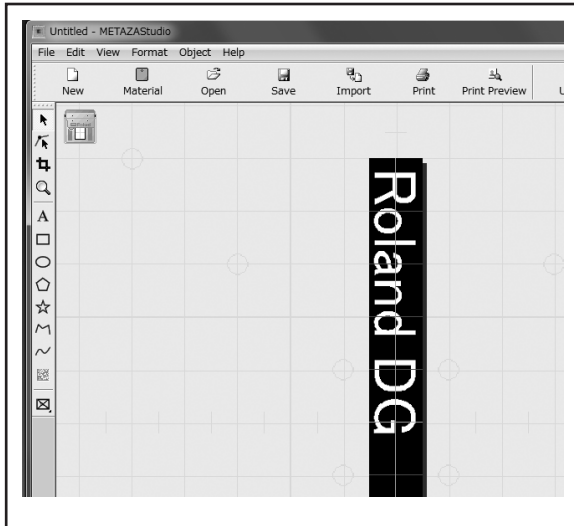

① Enter text remained.

② Move the text to any position of your preference.

☞ P. 64, "Adjusting the Location, Size, or Angle of a Text"



Point

The on-screen table scale corresponds to the scale for the center vise as shown in the figure. Adjust the position of the material to enable the text to be printed at the location you want.

☞ P. 41, "Loading Material Using the Center Vise"

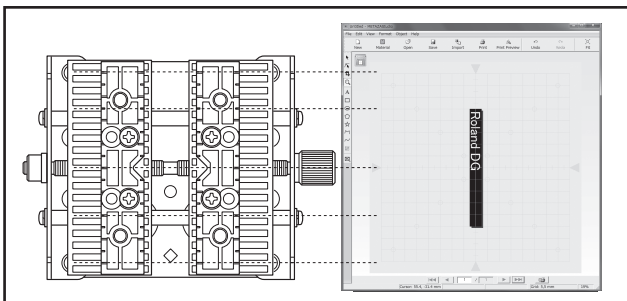

4-6 Register New Material

How to Register Wide Variety of Material

METAZASstudio includes preregistered material of four shapes. To print material not registered in METAZASstudio, first register it as a new material. This prevents the printing area from being limited and the marking pin from being damaged as the result of hitting the edge of material.

The following three methods are available for registering material. For detailed information about the procedures, refer to the online help for METAZASstudio.

- ☞ P.10, "How to Display Help for Software"
- ☞ METAZASstudio online help ("Hint and Tips" > "Registering Favorite Material")

Importing a bitmap image

If an image of the material is available, you can import the image. Note, however, that only bitmap data can be used. Other requirements are as follows.

- **File format : Must be either BMP (bitmap) or JPEG**
- **Number of colors : Binary (black and white — portions corresponding to the material must be black-filled)**

Scanning the material with a commercially available scanner

When no image of the material is available, or the shape of the material is complex, you can scan the material on a commercially available scanner and import the image produced. In this regards, the requirements are as follows.

- **Scanner : Scanner that supports TWAIN_32.**
- **Number of colors : Binary (black and white — portions corresponding to the material must be black-filled)**

Drawing the shape of the material

If the material is a square, circle, or other such simple shape, either singly or in combination, you can use the drawing tools to draw the shape of the material, then register it.

4-7 METAZA Driver Settings

Keeping the settings of METAZA Driver

At the setting window for METAZA driver, you can make the settings for a wide variety of items, including the size of the material and the method used for printing. Any changes you make at this window (the window displayed by using the procedure described here) remain in effect even after you restart METAZAStudio.

Procedure

1 Windows 7

From [Start] menu, click [Control Panel] → [Hardware and Sound] → [Devices and Printers].

Windows Vista

From [Start] menu, click [Control Panel] → [Hardware and Sound] → [Printers].

Windows XP

From [Start] menu, click [Control Panel] → [Printers and Other Hardware] → [Printers and Faxes].

2

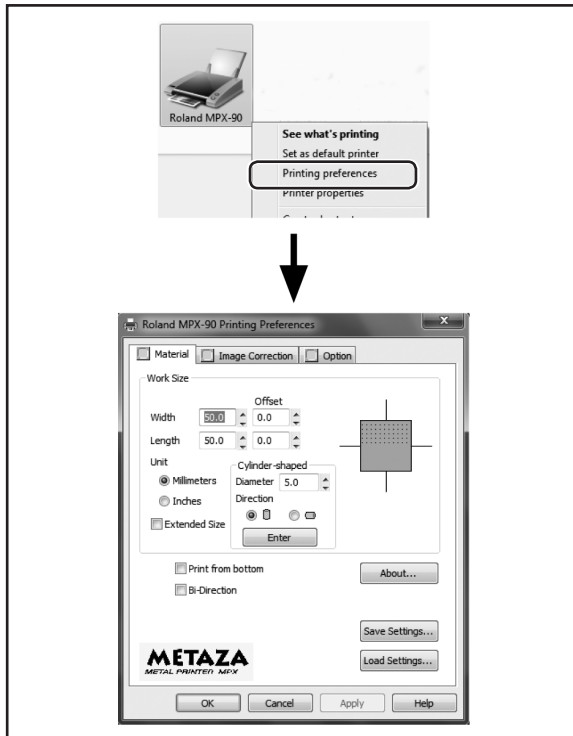

1 Right-click [Roland MPX-90].

2 Click [Printing Preferences].

The setting window for METAZA Driver appears.



Point

Going to the METAZAStudio [File] menu and clicking [Print Setup], then, in the [Print Setup] window, clicking [Properties], displays the same window as the one that appears using “Displaying the Setting Window,” described above. Any changes you make while at this window disappear when you restart METAZAStudio. It is recommended to use this window when you temporarily change the METAZA driver settings.

4-8 About Dr. Engrave

What is Dr. Engrave?

Dr. Engrave is printing software for plate materials.

It can read a text file in which data is separated by commas or tabs into the character field. You can use the files created with spreadsheet software and database software which have the text write function.

For more information, see Help of Dr. Engrave.

☞ P. 10, "How to Display Help for Software"

Points to note when using Dr. Engrave

- Setting of the material size (or the print area size) must be done in the setting window for METAZA Driver.
☞ P. 83, "METAZA Driver Settings."
- Set the material in a way that the center of the material (or the print area) comes to the center of the table (or the center vise).
☞ "How to Place Material" in P. 36, "Loading Material Using the Adhesive Sheet," p.40, "Using the Center Vise"

4-9 More Advanced Other Operations

More Advanced Other Operations You Can Accomplish with METAZAStudio

METAZAStudio has some further useful functions, which are not explained in this document. Major functions are given below. For more information on how to operate METAZAStudio, refer to the online help for the program.

☞ P. 10, "How to Display Help for Software"

Make images of people more prominent

When the machine prints data created using METAZAStudio, light and dark are expressed by making colors close to white darker and colors close to black lighter. This means that dark hair or clothing may be printed light, making the outline of the person indistinct. (Depending on the data, such hair or clothing may not be printed at all.) In such cases, cropping the person and applying a border to the image enables you to make the image of the person stand out better when printed.

☞ METAZAStudio online help ("Operation Procedures" > "Step 3: Delete Unnecessary Parts from Image")

Register often-used shapes and images in advance

You can register often-used and generic-use shapes in the library, which enables you call them up and add them to your data whenever you need them. Registering logos and other graphics can add convenience. You can also register images.

☞ METAZAStudio online help ("Hints and Tips" > "Making Use of Library")

Create contour lines from images

You can print imported images with added contour lines. The data formats that you can import are JPEG and BMP (bitmap). To enable clean extraction of the contours, the data should meet the following conditions.

Gradations : Use images that do not contain continuous gradations and that have clearly defined borders between colors.]

Number of colors : Binary (black and white [recommended])

Resolution : High (Note, however, that the optimal resolution may vary according to the complexity of the shape and the size when printed.)

☞ METAZAStudio online help ("Hints and Tips" > "Creating Contour Lines from an Image")

Share files over the Internet

You can save images that contain material shapes as bitmap (BMP) files. You can then send the files over the Internet for confirmation of the finished results.

☞ METAZAStudio online help ("Hints and Tips" > "Creating Preview for Customers to Check Completion Image")

Optimize photograph images

You can automatically adjust the colors of a photograph image into those suitable for printing from MPX-90. This function is effective for a photograph image which uses a lot of colors.

☞ METAZAStudio online help ("Operation Procedure" > Step 2: Load and Image)

Performing Variable Printing

Printing a different object on each sheet after changing part of print data is called “variable printing”. Similar to address printing on postal cards, data can be continuously printed while changing contents.

A CSV file is required to perform variable printing. A CSV file can be created using a spreadsheet software, etc.

☞ METAZAStudio online help (“Hints and Tips” > “Performing Variable Printing”)

Chapter 5

Maintenance and Ad- justment

5-1 Daily Care	88
Points to Note on Daily Care	88
Cleaning the Adhesive Sheet	88
Cleaning the Body and Cover	89
Cleaning of the Head Cap	89
5-2 Adjusting the Marking Pin	90
Checking the State of the Marking Pin	90
Adjusting the Striking Force of the Pin	91
5-3 Composition Registration and Striking-force Adjustment.....	92
Registering a Composition and Adjusting the Striking Force.....	92
5-4 Adjustment of the Origin-point Location.....	95
Adjusting the Location of the Machine's Origin Point	95
5-5 The Replacement of the Head Cap	98
The Replacement Cycle for the Head Cap.....	98
5-6 Head Replacement.....	99
The Replacement Cycle for the Head	99
How to Replace the Head.....	100

5-1 Daily Care

Points to Note on Daily Care

⚠️ WARNING **Never use gasoline, alcohol, thinner, or any other flammable material.**
Doing so may cause fire.

⚠️ CAUTION **Never touch the heads immediately after printing has finished.**
Doing so may cause burns.

- **This machine is a precision device, and is sensitive to dust and dirt. Be sure to carry out day-to-day cleaning.**
- **Never use solvents such as thinner, benzene, or alcohol.**
- **Never attempt to oil or lubricate the machine.**
- **Never apply silicone substances (oil, grease, spray, etc.) to the machine. Doing so may cause poor switch contact.**

Cleaning the Adhesive Sheet

Buildup of dust or the like on the adhesive sheet can reduce the sheet's adhesive force, making it difficult to secure material in place. If the adhesive force has been reduced, then wash the adhesive sheet.

How to Wash

Immerse the adhesive sheet in water, and wash the sheet by gently stroking its surface. If the soiling of the adhesive sheet is severe, wash it using diluted neutral detergent. Rinse thoroughly with water to remove all detergent completely.

Be sure to comply with the following instructions.

If not, the surface of the adhesive sheet is damaged, lowering the adhesiveness.

- **Never scrub the adhesive sheet using a scrubbing pad or sponge.**
- **Never stretch or bend the adhesive sheet when washing it.**

How to DRY

Allow to dry completely, out of direct sunlight.

Cleaning the Body and Cover

Use a cloth moistened with water then wrung well, and wipe gently to clean. The surface of the cover is easily scratched, so use a soft cloth.

Cleaning of the Head Cap

Detach the head cap mounted on the machine and remove dirt and dust inside the head cap. Printing without removing dirt and dust from the head cap may damage materials and/or affect the print quality.

5-2 Adjusting the Marking Pin

Checking the State of the Marking Pin

MPX-90 Head Manager indicates the amount of pin usage.

When the indicator is shown in red, replace the head with a new one. Even when the indicator is not displayed in red, if the print quality is not satisfactory or the unevenness of the printed image persists, replace the head with a new one.

☞ P. 100, "How to Replace the Head," p. 105, "The printed image is unattractive," p. 106, "The image is uneven"

Procedure

- 1 From [Start] menu, click [All Programs] (or [Programs]) → [MPX-90 Head Manager] → [MPX-90 Head Manager].**
MPX-90 Head Manager starts.

- 2 Switch on the power to the machine.**

☞ P. 30, "Switching On the Power"

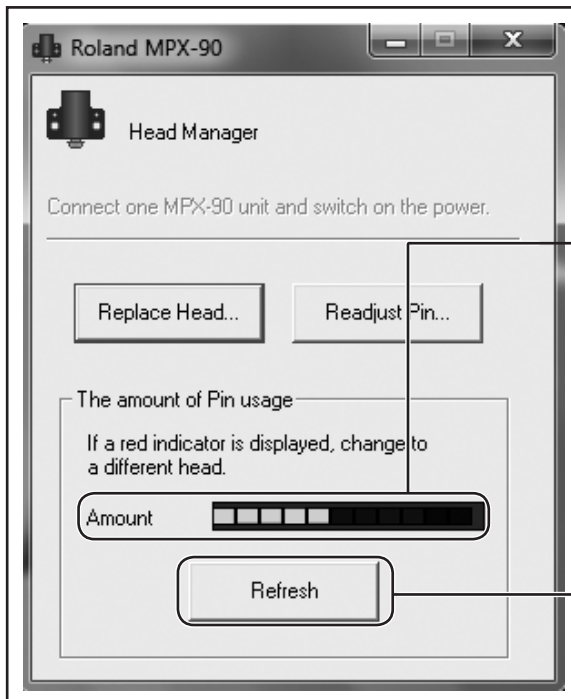

The amount of pin usage is indicated in this window. The level indicator increases little by little as the pin is used to strike the material. The rate of increase varies depending on the material used for printing. When the indicator is displayed in red, it is time for replacement of the head.

This refreshes the screen to display the latest information.

Adjusting the Striking Force of the Pin

You can adjust the striking force of the pin by using MPX-90 Head Manager. Pin adjustment involves striking the pattern shown in the figure. Prepare a piece of test-use printing material (brass) or other material measuring about 60 mm (2.3 in.) by 60 mm (2.3 in.).

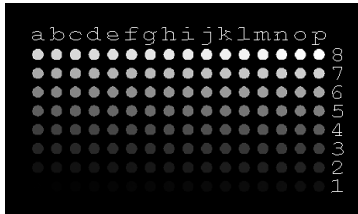

Adjustment pattern

Procedure

- 1 From [Start] menu, click [All Programs] (or [Programs]) → [MPX-90 Head Manager] → [MPX-90 Head Manager].
MPX-90 Head Manager starts.
- 2 Switch on the power to the machine.
☞ P. 30, "Switching On the Power"

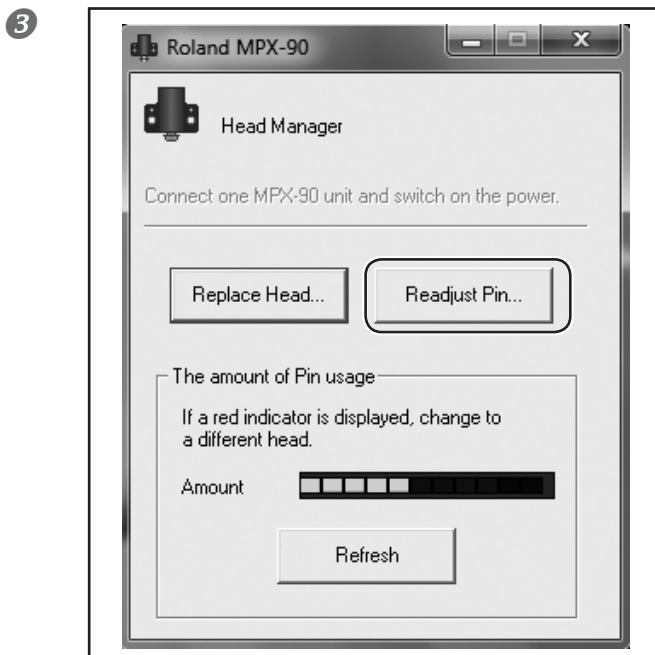

Click [Readjust Pin].

Follow the on-screen instructions to perform adjustment for the pin.

Set a material using the adhesive sheet and table.

☞ P. 36, "Loading Material Using the Adhesive Sheet"

Print the adjustment pattern using the head cap.

☞ P. 36, "Loading Material Using the Adhesive Sheet"

If the adjustment pattern fails to be printed, see the sections given below.

☞ P. 104, "The printed location isn't where desired," p. 105, "Striking is performed, but nothing is printed"

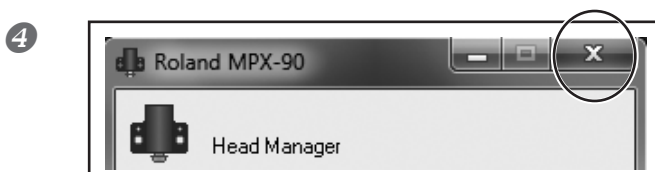

When you have finished, click



The window closes.

5-3 Composition Registration and Striking-force Adjustment

Registering a Composition and Adjusting the Striking Force

Here you register a composition and adjust the striking force to match its hardness and other parameters. With this machine, performing printing using a striking force appropriate to the composition of the material used can obtain printing results of even higher quality. The driver for the machine has premade settings for a number of compositions and their appropriate striking forces, but you can also register compositions and their optimal striking forces yourself. You can also carry out later adjustment of the striking force of compositions you've registered yourself, in order to obtain better printing results.

Procedure

1 Windows 7

From [Start] menu, click [Control Panel] → [Hardware and Sound] → [Devices and Printers].

Windows Vista

From [Start], click [Control Panel] → [Hardware and Sound] → [Printers].

Windows XP

From [Start], click [Control Panel] → [Printers and Other Hardware] → [Printers and Faxes].

2

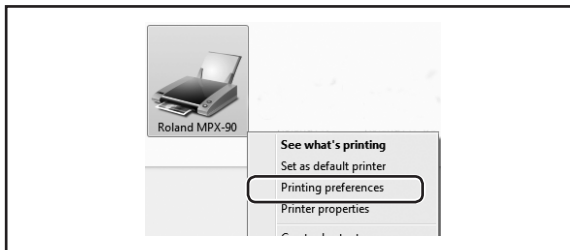

① Right-click [Roland MPX-90].

② Click [Printing Preferences].

Setting Window for METAZA driver appears.

3

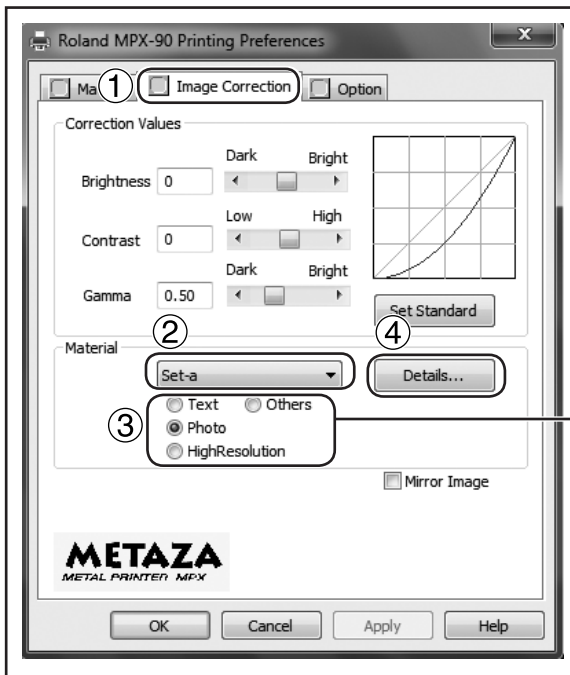

① Click the [Image Correction] tab.

② For [Material], select a custom material (settings a through d).

③ Select print Mode.

☞ METAZA Driver online help ([Correction] tab)

④ Click [Details].

The [Details] window appears.

Text

When you want to print text and other images with clear outlines

Photo

When you want to print photographs and other images with gradation

High Resolution

When you want to express small text and small patterns clearly

Others

When you want to make the resolution setting and other settings of an image

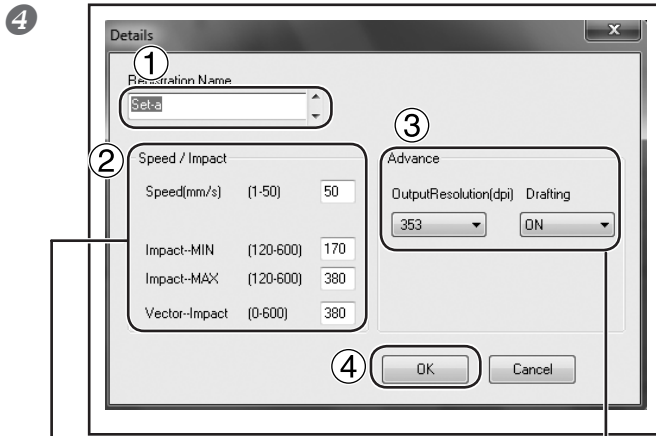

① Enter a name for the composition you're registering.

② Enter [Speed/Impact]

The printing results vary according to the hardness of the material. Adjust to match the material.

⇨ METAZA Driver online help ("[Correction] tab" > "[Material Details] dialog box")

③ Making the [advance] setting

[Advance] is available only when Print Mode is [Other].

⇨ METAZA Driver online help ("[Correction] tab" > "[Material Details] dialog box")

④ Click [OK].

[Advance] window close.

Impact--MIN

You can set the minimum value of print impact for an image. Raise the value when dark areas of the image are not struck. Lower the value when dark areas of the image are whitish or when overall striking is too forceful.

Impact--MAX

You can set the maximum value of print impact for an image. Raise the value when bright areas of the image are struck with too little force or when overall striking is too weak. Lower the value when bright areas of the image are struck with too much force.

Vector Impact

You can set the maximum value of print impact for a line.

Output Resolution

You can specify the number of dots per inch.

Drafting

You can skip image information in increments of one dot.

Materials and Values of Impact (Reference values)*

Material	Impact--MIN	Impact--MAX
Brass or Copper	200	350 to 450
Iron or Stainless steel	200	400 to 500
Titanium	200	500 to 600

* The coating of a coated material may come off when the stamping force is too strong. If the coating comes off, it may cause a malfunction. Adjust the print impact so that the coating will not come off.

Continue on the next page

5

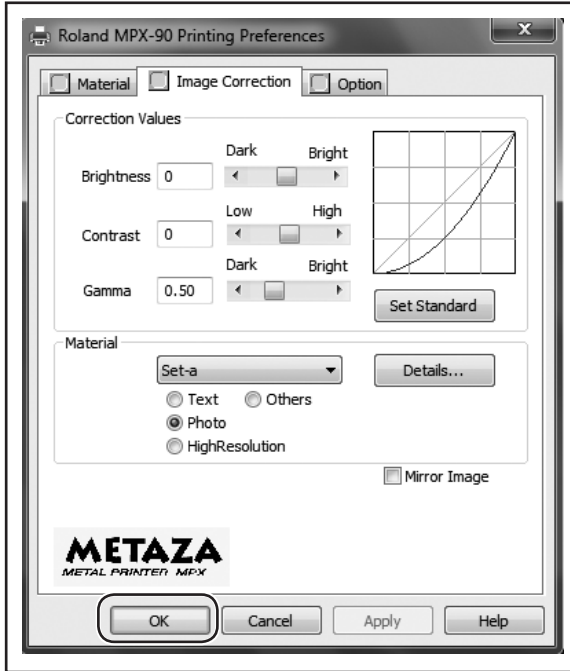

Click [OK].
METAZA Driver setting window closes.

This is the end of registration of a material and the striking force suitable for it. To obtain printing results of higher quality, repeat to perform test print or to strike a same material, and adjust the value of print impact, etc. based on the print results.

5-4 Adjustment of the Origin-point Location

Adjusting the Location of the Machine's Origin Point

The origin point of the machine must be the center of the scale on the table. You can check the origin-point location by printing calibration data. Adjust the origin point if it is displaced.

Prepare a plate-shaped material larger than 20 millimeters square.

1. Print calibration data.

1 Switch on the power to the machine.

☞ P. 30, "Switching On the Power"

2 Mount material.

Set material using the adhesive sheet and table.
Be sure to use the head cap.

☞ P. 36, "Loading Material Using the Adhesive Sheet"

3 Start METAZAStudio.

☞ P. 44, "Starting METAZAStudio"

4

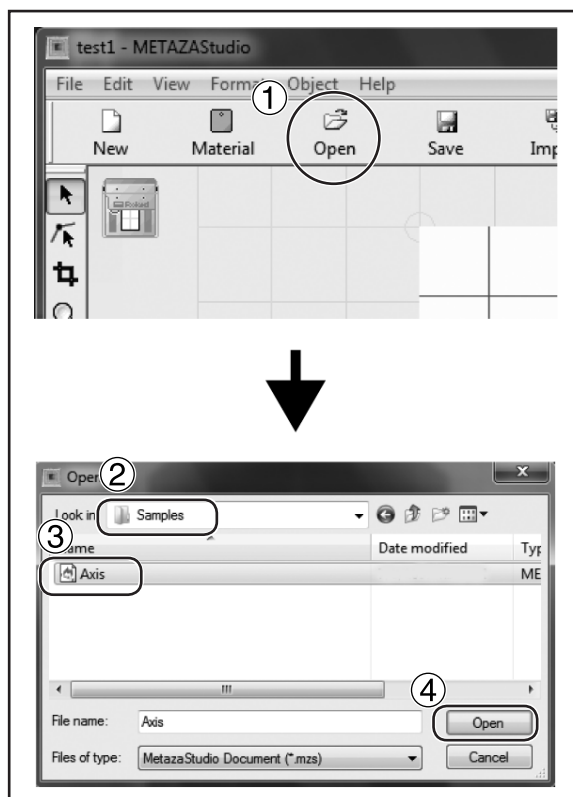

1 Click .

2 For [Look in], select the [Samples] folder in the [METAZAStudio] folder*.

* The folder where METAZAStudio is installed

3 Select [Axis.mzs]

4 Click [Open].

5 Start printing.

☞ P. 52, "Starting Printing"

2. Measure the displacement of Origin-point Location and type in the correction values.

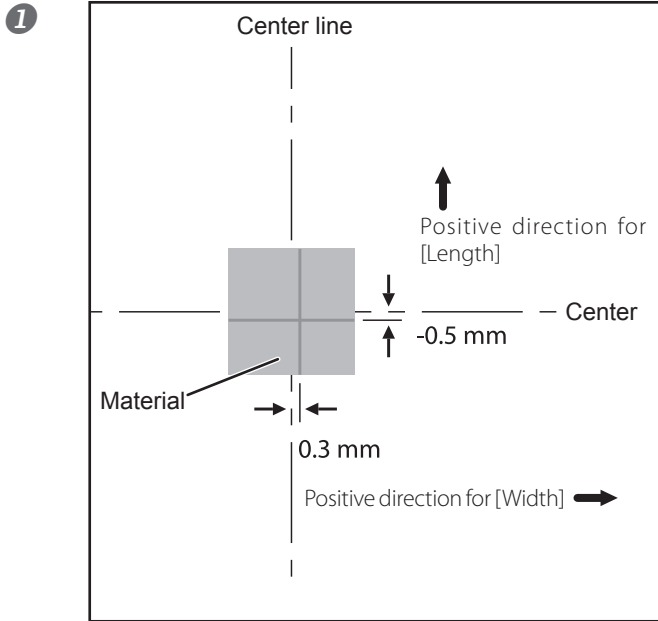

Measure and note down the offset between the centerline on the table scale and the crossed lines on the material.

In the example shown in the figure, the [Width] value is displaced by 0.3 mm in the positive direction and the [Length] value is offset by 0.5 mm in the negative direction.

2 **Windows 7**
From [Start] menu, click [Control Panel] → [Hardware and Sound] → [Devices and Printers].

Windows Vista

From [Start] menu, click [Control Panel] → [Hardware and Sound] → [Printers].

Windows XP

From [Start] menu, click [Control Panel] → [Printers and Other Hardware] → [Printers and Faxes].

The [Printers] folder opens.

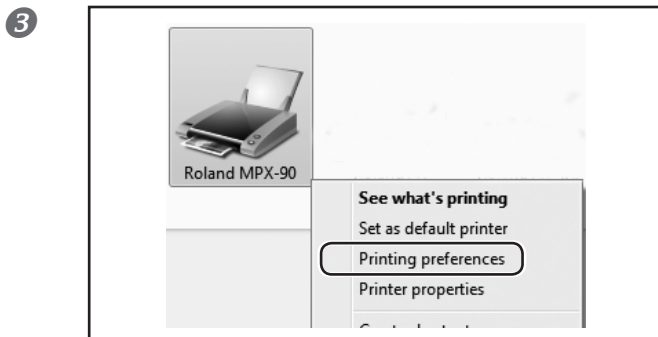

Right-click [Roland MPX-90].
Click [Printing Preferences].

The setting window of METAZA Driver appears.

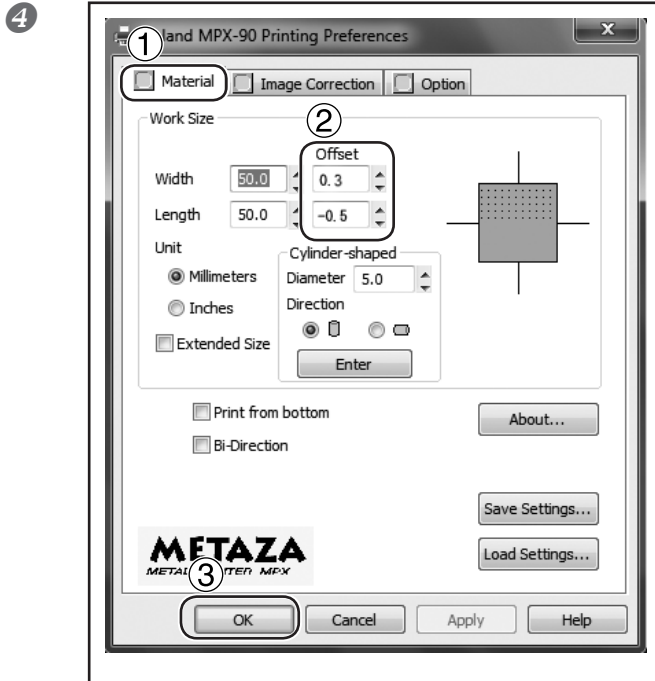

- ① Click the [Material] tab.
- ② In the width and length fields for [Offset], enter the displacement values you noted in step 2.-①.

In the case of the figure in step 2.-①, enter 0.3 in [Width] and -0.5 in [Length].

- ③ Click [OK].

The window closes.



Point

When the setting window of METAZA Driver for METAZAStudio is displayed, the values for any settings made there are temporary, and are not saved.

☞ P. 83, "Keeping the settings of METAZA Driver"

5-5 The Replacement of the Head Cap

The Replacement Cycle for the Head Cap

When the head cap becomes worn away as shown in the figure below, it is time for replacement. Replace the head cap with a new one appropriately.

The degree of wear may vary according to printing conditions. In particular, printing that makes extensive use of island fill and other line-drawing operations on materials such as aluminum results in especially rapid wear because of the extensive unevenness of the material surface. Periodically check the state of the head cap to ensure that it is replaced as often as needed.

☞ P. 36, "Loading Material Using the Adhesive Sheet," p. 41, "Loading Material Using the Center Vise"

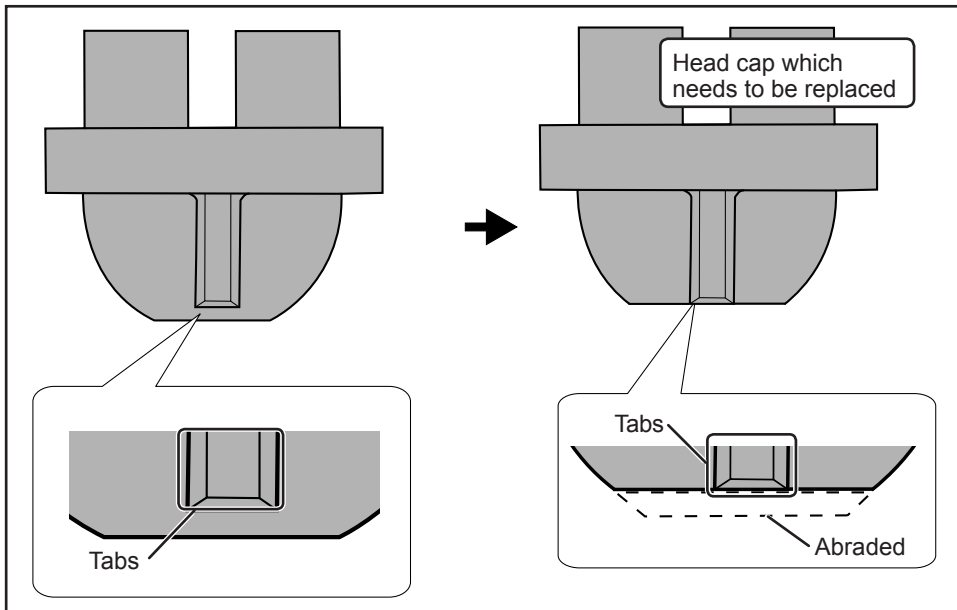

5-6 Head Replacement

The Replacement Cycle for the Head

MPX-90 Head Manager shows the amount of pin usage.

If the indicator for the pin you're using is red, then replace it with a new head. If attractive printing is impossible or printed images are uneven even though the scale is not red, then change to a new head.

☞ P. 91, "Adjusting the Striking Force of the Pin," p. 105, "The printed image is unattractive," p. 106, "The image is uneven"

A General Guide of Head Life

About 4,000 plates can be printed under the following conditions.

Conditions of Use

Material used : MD-NI (Roland nickel-plated plate)

Printing area : 30 mm (1.1 in.) X 23 mm (0.9 in.)

Print Mode : Photo

Printing rate : 35% (25,000 dots per plate)

How to Replace the Head

MPX-90 Head Manager is used for the head replacement operation.

The pattern shown in the figure is struck during the head replacement operation. You need to prepare a test print material (brass), which is supplied with a replacement head (MPH-90), or a material equal to or larger than 60 mm (2.3 in.) x 60 mm (2.3 in.).

A replacement head is sold separately. Consult your authorized Roland DG Corp. dealer.

- **Do not stop the replacement operation halfway.**
- **Do not use the head of which the marking pin is worn out.**
- **Do not use the head which is detached from the machine.**

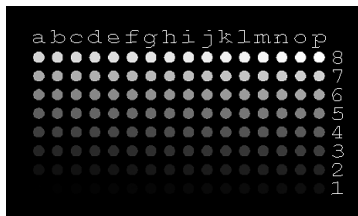

Adjustment pattern

Procedure

- 1 From [Start] menu, click [All Programs] (or [Programs]) → [MPX-90 Head Manager] → [MPX-90 Head Manager].
MPX-90 Head Manager starts.

- 2 Switch on the power to the machine.
☞ P. 30, "Switching On the Power"

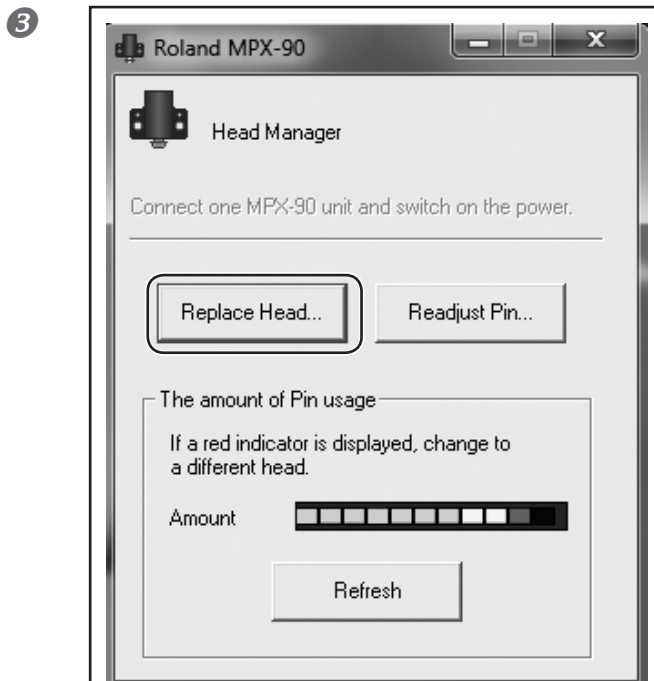

Click [Replace Head].

Follow the on-screen instructions to perform adjustment for the pin.

Set material using the adhesive sheet and table.

☞ P. 36, "Loading Material Using the Adhesive Sheet"

Print the adjustment pattern using the head cap.

☞ P. 36, "Loading Material Using the Adhesive Sheet"

If the adjustment pattern fails to be printed, see the sections given below.

☞ P. 104, "The printed location isn't where desired," p. 105, "Striking is performed, but nothing is printed"

4



When you have finished, click



The window closes.

Chapter 6

Appendix

6-1 What to Do If.....	104
The power supply light is blinking.....	104
The machine doesn't run even when printing data is sent.	104
The printed location isn't where desired	104
Striking is performed, but nothing is printed.	105
The printed image is unattractive.	105
The image is uneven.	106
The image is always faint at the same location.....	106
Installation for METAZA driver is Impossible	107
Uninstalling METAZA driver	108
6-2 When Moving the Machine	111
Attach the retaining materials to the machine.	111
6-3 Locations of the Power Rating and Serial Number Labels ..	114
6-4 Specification	115
Main Unit Specifications	115
System Requirements for USB Connection	115

6-1 What to Do If

The power supply light is blinking.

Do you turn ON the power as the head position is set?

If the power is turned ON as the head position is set, the power supply light blinks immediately after the initial operation is completed. If the head is set at an inappropriate position in relation to the surface height of the material, the surface of the material may be scratched and/or the marking pin may be damaged. To prevent these failures from occurring, the power supply light blinks.

Loosen the knob counterclockwise once and reset the setting of the head position. After resetting it, tighten the knob again. Press the Power/Movement button, and the power supply light stops blinking and is lights.

If you do not use the head cap, do you adjust the head position based on the surface height of the material?

Turn OFF the power. Stop printing if it is underway. In the case that you perform printing without using the head cap, if the head position is lower than the surface height of the material, the tip of the head comes into contact with the surface of the material, and the power supply light blinks. Adjust the head position to an appropriate position based on the surface height of the material and secure the head firmly with the knob.

☞ P. 31, "Switching Off the Power," p. 36, "Loading Material Using the Adhesive Sheet," p. 41, "Loading Material Using the Center Vise," p. 54, "Stopping Printing Operations"

Do you lift the head when you turn ON the power?

Turn OFF the power. When you lift the head to the topmost, the machine considers that the surface height of the material is out of the print conditions, and the power supply light blinks. Be sure to handle the machine in accordance with User's Manual.

P. 31, "Switching Off the Power"

Is a change in the height of the print surface too large?

Stop printing. If a change in the height of the print surface is too large, the power supply light blinks. Check the conditions of printable materials and select a material again.

☞ P. 33, "Preparing Material to Print," p. 54, "Stopping Printing Operations"

Do you set a material without using the supplied table (or the center vise)?

Turn OFF the power. Stop printing if it is underway. If you set a material of which surface height is low without using the supplied table (or the center vise), the machine considers that the surface height of the material is out of the conditions of the printable materials, and the power supply light blinks. Make sure to set a material using the supplied table (or the center vise).

☞ P. 31, "Switching Off the Power," p. 36, "Loading Material Using the Adhesive Sheet," p. 41, "Loading Material Using the Center Vise," p. 54, "Stopping Printing Operations"

Is the knob loosened?

Stop printing. If the knob becomes loose in the case that the head cap is not used, the head position does not match the surface height of the material, and consequently the power supply light blinks. When you set the head position, make sure to tighten the knob firmly.

☞ P. 36, "Loading Material Using the Adhesive Sheet," p. 41, "Loading Material Using the Center Vise," p. 54, "Stopping Printing Operations"

The machine doesn't run even when printing data is sent.

Is the power switched on?

Make sure the Power/Movement button light is on. If it is dark, press the Power/Movement button to switch on the power.

☞ P.30, "Switching On the Power"

Is the power cord connected correctly?

If it is not connected correctly, refer to the page indicated below and connect it properly.

☞ P. 23, "Cable Connections"

Is the cable used for the connection to the computer connected correctly?

Check if the connection cable is disconnected.

The printed location isn't where desired

Is the material loaded at the correct location?

If striking is being performed at a location other than where the material is loaded, then reload the material.

☞ P. 36, "Loading Material Using the Adhesive Sheet," p. 41,
"Loading Material Using the Center Vise"

Is the origin point of the machine displaced?

The center of the table scale may not coincide with the machine's printing origin point. The origin point of the machine must be the center of the scale on the table. You can check the origin point location by printing calibration data. To correct displacement between the scale center and the printing origin point.

☞ P. 95, "Adjustment of the Origin-point Location"

Striking is performed, but nothing is printed.

Is the material to be printed in line with the parameters for printable material?

Prepare and use printable material.

☞ P. 33, "Preparing Material to Print"

If you're not using a head cap, does the head position match the surface height of the material in the case that you do not use the head cap?

Check if the head position matches the surface height of the material in the case that you do not use the head cap. Printing cannot be performed if the head position does not match the height position of the material. Adjust the head position and then tighten the knob firmly.

☞ P. 36, "Loading Material Using the Adhesive Sheet," p. 41,
"Loading Material Using the Center Vise"

Is the marking pin bent or broken?

When nothing is printed, and changing the location where the material is loaded, the parameters for the material, or the height of the head unit does not correct the problem, then the marking pin may be bent or broken. Try changing to an unused marking pin and carry out test printing. If you can print with the new marking pin, it means the marking pin you had been using is bent or broken. Continue using the new marking pin.

☞ P.100, "How to Replace the Head"

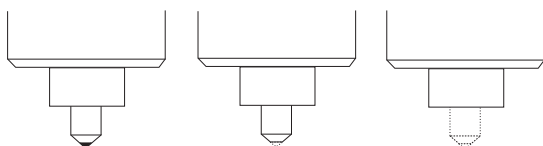

Not bent or
broken

Bent or broken

Bent or broken

The printed image is unattractive.

Are the settings for the material in the driver's setting window correct?

Choose the composition of the loaded material.

Even if the composition of the material is the same, the hardness of the printed surface may vary greatly depending on the casting method, the composition of impurities, the presence of plating, and so on. In such cases, perform fine adjustment of the striking force to match the material.

☞ P. 92, "Registering a Composition and Adjusting the Striking Force"

Is the image printed clearly?

If the image is not printed clearly, adjust the brightness of the image. Perform printing while increasing the brightness of [Gamma] or [Brightness] in the driver's setting window a little at a time. At this time, leave the material loaded and perform overstriking at the same location. Continue changing settings and performing printing until you obtain the darkness you want.

☞ P. 75, "Checking the Finished Results in the Preview Window"

Are grayscale tones printed clearly?

When grayscale tones are indistinct, go to the setting window for the driver ("Advanced" at the [Image Correction] tab) and adjust the force of striking. Perform printing while leaving the value for [Impact--MAX] unchanged and increasing the value for [Impact--MIN] a little at a time. At this time, leave the material loaded and perform overstriking at the same location. Continue changing the settings in the driver's setting window and performing printing until you obtain the darkness you want.

☞ P. 92, "Registering a Composition and Adjusting the Striking Force"

More Information about Overstriking

The various setting values determined with overstriking are effective only when performing overstriking under identical conditions. The same results are not necessarily obtained when printing is performed with a new piece of material with only the conditions made the same, without performing overstriking.

Is the marking pin worn?

Attractive printing may be impossible if the marking pin becomes worn. Adjust the pin or change it to a new one.

☞ P. 90, "Checking the State of the Marking Pin," p.100, "How to Replace the Head"

The image is uneven.

Is the printed surface slightly uneven?

If no head cap is attached, then attach a head cap and perform printing. If you're using material that can be damaged by printing with the head cap attached, then replace it with material that has a level printing surface.

☞ P. 32, "Head Caps," p.33, "Preparing Material to Print"

Is the printed surface at an angle?

If no head cap is attached, then attach a head cap and perform printing. If you're using material that can be damaged by printing with the head cap attached, then replace it with material that has a level printing surface.

☞ P. 32, "Head Caps," p.33, "Preparing Material to Print"

Is the image darkness uneven?

Performing overstriking with the material left loaded at the same location may improve the image quality. Try performing overstriking with different settings for [Gamma], [Brightness], or [Contrast] in the driver's setting window.

☞ P. 75, "Checking the Finished Results in the Preview Window"

Was bidirectional printing performed?

Bidirectional printing can shorten the printing time, but the image quality may suffer. If this happens, go to the driver's setting window and clear the selection for [Bidirection], then redo printing.

☞ METAZA Driver online help ([Material] tab)

Is the marking pin worn?

Attractive printing may be impossible if the marking pin becomes worn. Check the state of the marking pin. If the marking pin becomes worn, replace the head with a new one.

☞ P. 90, "Checking the State of the Marking Pin," p. 100, "How to Replace the Head"

The image is always faint at the same location.

Is the height displacement for the printed surface excessive?

If the image is always faint at the same location even though you're performing printing using a head cap, the height displacement for the printed surface may be excessive. Recheck the parameters of materials that the machine can print and select material that meets the parameters. Also, image quality is not assured when printing photographic data on a curved surface with this machine.

☞ P. 33, "Preparing Material to Print"

Have you tried to adjust the levelness of the machine?

If you're not using a head cap If the image is often faint at the same location, such as near the front right area of the table, then adjusting the levelness of the machine may improve the image quality. Please note that this is not effective when unevenness in the image is unrelated to the printing location, such as when uneven areas vary from one piece of material or image to another. We recommend using a head cap whenever such use is possible.

☞ P. 32, "Head Caps"

Procedure

1. Using an adhesive sheet, load a piece of included test-use printing material at the center of the table.

If the included material has been used up, then prepare a piece of material that is larger than 60 mm (2.3 in.) and has a smoothness of 0.05 mm (0.002 in.) or less. Make a print without using the head cap.

☞ P. 36, "Loading Material Using the Adhesive Sheet"

2. Go into the [Printers] folder.

3. Right-click the [Roland MPX-90] and open the setting screen for METAZA driver. Click [Printing Preferences].

The setting window for METAZA driver appears.

4. Click the [Option] tab.

5. Click [Test print].

The test pattern is printed on the material.

6. Use the scale to read and note down locations where the test pattern is not continuous or not visible.

Note down the values in all four directions (front, back, left, and right).

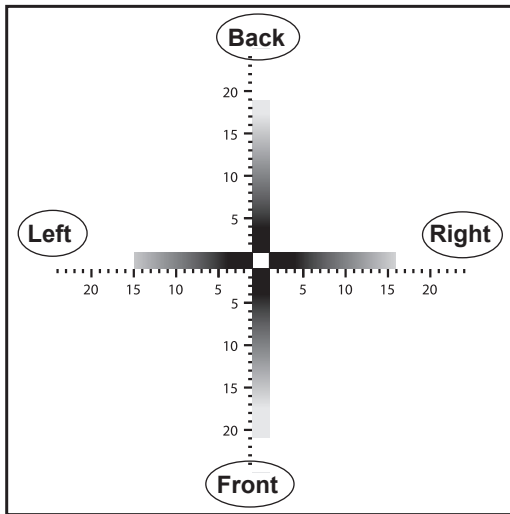

7.
 - ① Select [Correct slope]
 - ② Enter the scale values you noted into the driver.
 - ③ Click [OK]

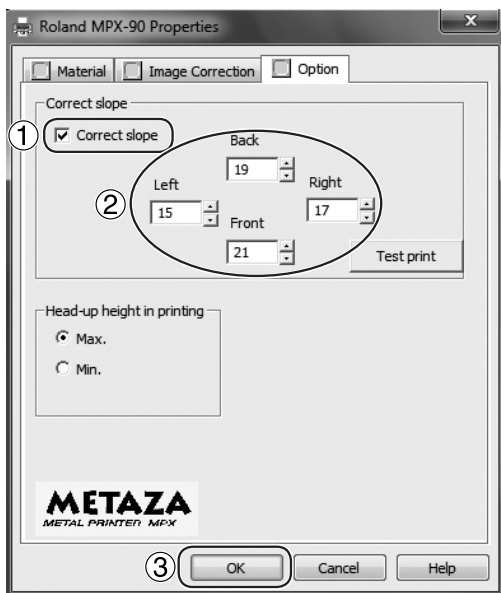

Installation for METAZA driver is Impossible

If installation quits partway through, or if the wizard does not appear when you make the connection with a USB cable, take action as follows.

Windows 7

1. Connect the machine with the computer via a USB cable, and turn on the machine.
2. If the [Found New Hardware] window appears, click [Cancel] to close it. Make sure that all USB cables connected with the printers except this machine are disconnected.
3. Click the [Start] menu, and right-click [Computer]. Click [Properties].
4. Click [Device Manager]. When [User Account Control] appears, click [Continue].
5. The [Device Manager] appears.
6. At the [View] menu, click [Show hidden devices].
7. In the list, find and double-click [Printers] or [Other device]. When the model name you are using or [Unknown device] appears below the item you selected, click it to choose it.
8. Go to the [Action] menu, and click [Uninstall].
9. In the [Confirm Device Uninstall] window, click [OK] without selecting [Delete the driver software for this device]. Close [Device Manager].
10. Detach the USB cable connected to the printer, and restart Windows.
11. Uninstall METAZA Driver.

- ☞ Carry out the steps from step 3 in page 104, "Uninstalling METAZA driver Windows 7" to uninstall METAZA Driver.
11. Install the driver again according to the procedure in page 25, "Installing METAZA driver."

Windows Vista

1. Connect the machine with the computer via a USB cable, and turn on the machine.
2. If the [Found New Hardware] appears, click [Cancel] to close it. Disconnect any USB cables for printers or other such equipment other than this machine.
3. Click the [Start] menu, then right-click [Computer]. Click [Properties].
4. Click [Device Manager]. The [User Account Control] appears, click [Continue].
5. The [Device Manager] appears.
6. At the [View] menu, click [Show hidden de-

vices].

6. In the list, find [Printers] or [Other device], then double-click it. When the model name you are using or [Unknown device] appears below the item you selected, click it to choose it.
7. Go to the [Action] menu, and click [Uninstall].
8. In "Confirm Device Uninstall" window, select [Delete the driver software for this device.], then click [OK]. Close the [Device Manager].
9. Detach the USB cable connected to the printer, and the restart Windows.
10. Uninstall METAZA Driver.

☞ Carry out the steps from step 3 in page 104, "Uninstalling

METAZA driver Windows Vista" to uninstall METAZA Driver.

11. Install the driver again according to the procedure in page 25, "Installing METAZA driver.

Windows XP

1. Connect the machine with the computer via a USB cable, and turn on the machine.
 2. If the [Found New Hardware Wizard] appears, click [Finish] to close it. Disconnect any USB cables for printers or other such equipment other than this machine.
 3. Click the [Start] menu, then right-click [My Computer]. Click [Properties].
 4. Click the [Hardware] tab, then click [Device Manager].
- The [Device Manager] appears.
5. At the [View] menu, click [Show hidden devices].
 6. In the list, find [Printers] or [Other device], then double-click it. When the model name you are using or [Unknown device] appears below the item you selected, click it to choose it.
 7. Go to the [Action] menu, and click [Uninstall].
 8. In "Confirm Device Uninstall" window, click [OK].
 9. Close the [Device Manager] and click [OK].
 10. Detach the USB cable connected to the printer, and the restart Windows.
 11. Uninstall METAZA driver.

☞ Carry out the steps from step 3 in page 104, "Uninstalling

METAZA driver Windows Vista" to uninstall METAZA Driver.

12. Install the driver again according to the procedure in page 25, "Installing METAZA driver.

Uninstalling METAZA driver

When uninstalling METAZA driver, perform following operation.

Windows 7

1. Switch off the power to the machine, then detach the connector cable between the machine and the computer.
 2. Log on to Windows as "Administrators" right.
 3. From the [Start] menu, click [ControlPanel], and then click [Uninstall a program].
 4. Click the driver for the machine to delete to select it, then Click [Uninstall].
 5. A message prompting you to confirm deletion appears. Click [Yes].
 6. From the [Start] menu, choose [All Programs], then [Accessories], then [Run], and then click [Browse].
 7. Choose the name of the drive or folder where the driver is located. (*)
 8. Select "SETUP.EXE" and click [Open], then click [OK].
 9. The [User Account Control] appears, click [Allow].
- The Setup program for the driver starts.
10. Click [Uninstall] to choose it. Select the machine to delete, then click [Start].
 11. If it is necessary to restart your computer, a window prompting you to restart it appears. Click [Yes].

The uninstallation finishes after the computer restarts.

(*) When using the CD-ROM, specify the folder as shown below (assuming your CD-ROM drive is the D drive).

D:\Drivers\WIN7X64 (64-bit version)

D:\Drivers\WIN7X86 (32-bit version)

If you're not using the CD-ROM, go to the Roland DG Corp. website (<http://www.rolanddg.com/>) and download the driver for the machine you want to delete, then specify the folder where you want to expand the downloaded file.

Windows Vista

1. Switch off the power to the machine, then detach the connector cable between the machine and the computer.
2. Log on to Windows as "Administrators" right.

3. From the [Start] menu, click [Control Panel]. From the [Hard-ware and Sound] group, click [Printer].

[Printer] folder opens.

4. Click the model name's icon you are using. From the [Organize] menu, click [Delete]. The [User Account Control] appears, click [Continue].

5. A message prompting you to confirm deletion appears. Click [Yes].

6. In the [Printers] folder, right-click any location where no printer icon is present. From the [Run as administrator] menu, select [Server Properties]. The [User Account Control] appears, click [Continue].

7. Click the [Drivers] tab, then from the [Installed printer drivers] list, choose the machine to delete.

Click [Remove].

8. The [Remove Driver And Package] appears, select [Remove driver and driver package]. Click [OK].

9. When the prompt message appears, click [Yes].

10. The package and driver to delete are displayed. Make sure that what is displayed is the machine you want to delete, then click [Delete].

11. The items that have been deleted are displayed. Click [OK].

12. Click [Close] on [Remove Driver And Package] window.

13. From the [Start] menu, choose [All Programs], then [Accessories], then [Run], and then click [Browse].

14. Choose the name of the drive or folder where the driver is located. (*)

15. Select "SETUP.EXE" and click [Open], then click [OK].

16. The [User Account Control] appears, click [Allow].

The Setup program for the driver starts.

17. Click [Uninstall] to choose it. Select the machine to delete, then click [Start].

18. If it is necessary to restart your computer, a window prompting you to restart it appears. Click [Yes].

The uninstallation finishes after the computer restarts.

(*) When using the CD-ROM, specify the folder as shown

below (assuming your CD-ROM drive is the D drive).

D:\Drivers\WINVISTAX64 (64-bit version)

D:\Drivers\WINVISTAX86 (32-bit version)

If you're not using the CD-ROM, go to the Roland DG Corp. website (<http://www.rolanddg.com/>) and download the driver for the machine you want to delete, then specify the folder where you want to expand the downloaded file.

Windows XP

1. Switch off the power to the machine, then detach the connector cable between the machine and the computer.

2. Log on to Windows as "Administrators" right.

3. From the [Start] menu, click [Control Panel]. Click [Printers and Other Hardware], then click [Printers and Faxes].

4. Click the model name's icon you are using. From the [File] menu, choose [Delete].

5. A message prompting you to confirm deletion appears. Click [Yes].

6. Go to [File] and select [Server Properties].

7. Click the [Driver] tab, then from the [Installed printer drivers] list, choose the machine to delete.

8. Click [Delete]. When the prompt message appears, click [Yes].

9. From the [Start] menu, select [Run], then click [Browse].

10. From the [File Locations] list, choose the name of the drive or folder where the driver is located. (*)

11. Select "SETUP.EXE" and click [Open], then click [OK].

The Setup program for the driver starts.

12. Click [Uninstall] to choose it. Select the machine to delete, then click [Start].

13. If it is necessary to restart your computer, a window prompting you to restart it appears. Click [Yes].

The uninstallation finishes after the computer restarts.

(*) When using the CD-ROM, specify the folder as shown below (assuming your CD-ROM drive is the D drive).

D:\Drivers\WINXPX64 (64-bit version)

D:\Drivers\WINXPX86 (32-bit version)

If you're not using the CD-ROM, go to the Roland DG Corp. web-site (<http://www.rolanddg.com/>) and download the driver for the machine you want to delete, then specify

6-1 What to Do If

the folder where you want to expand the downloaded file.

6-2 When Moving the Machine

Attach the retaining materials to the machine.

When moving the machine, be sure to attach the retaining materials. Moving the machine without attaching the retaining materials may result in damage to the machine.

Procedure

1 Switching on the power.

☞ P. 30, "Switching On the Power"

2

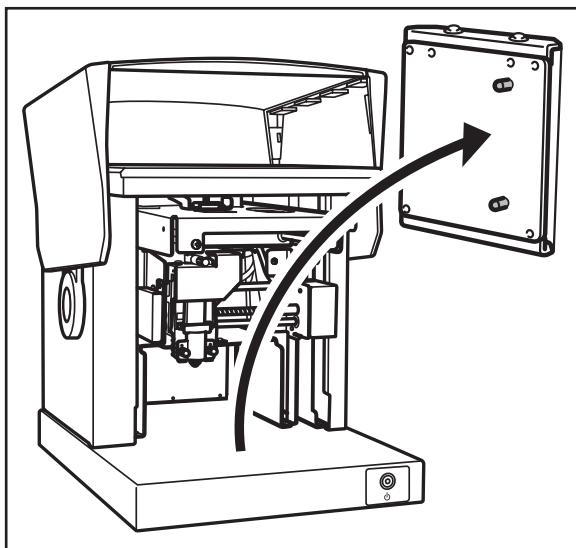

Detach the table (or the center vise).

3

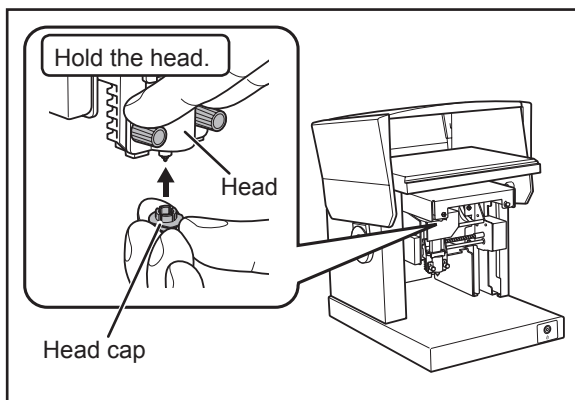

Attach a head cap to the tip of head.

4 Switching off the power.

☞ P. 31, "Switching Off the Power"

5

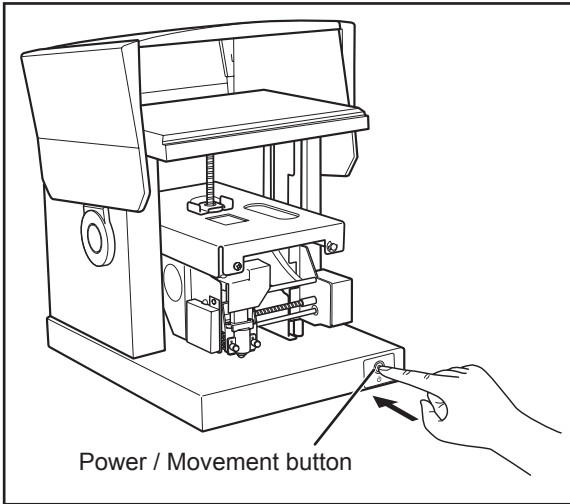

Hold down the Power/Movement button for ten seconds or longer. The head moves as shown in the figure.

6

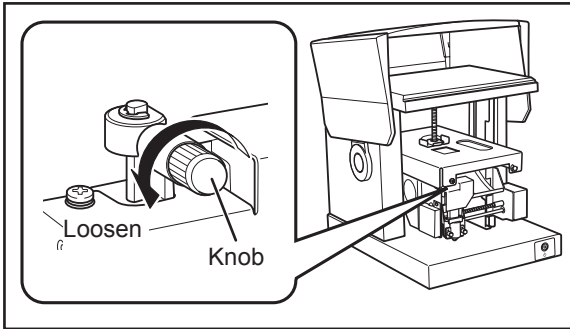

Loosen the knob

7

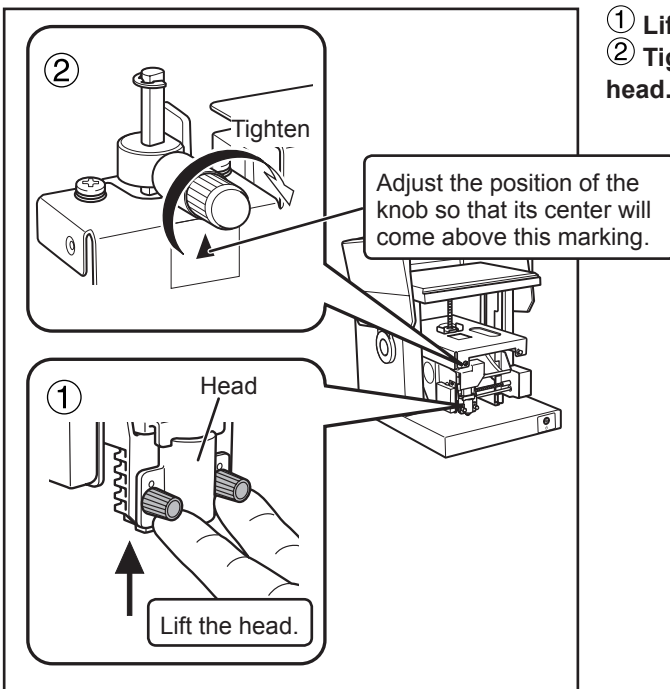

① Lift up the head.
② Tighten the knob as lifting the head.

8

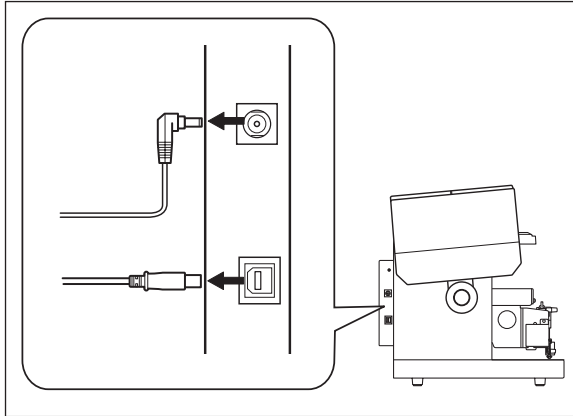

Unplug the cables.

9

Attach the retaining materials.

The machine is to be secured at three points (with 5 screws). Attach all the retainers and wind up the screws with the provided hexagonal wrench.

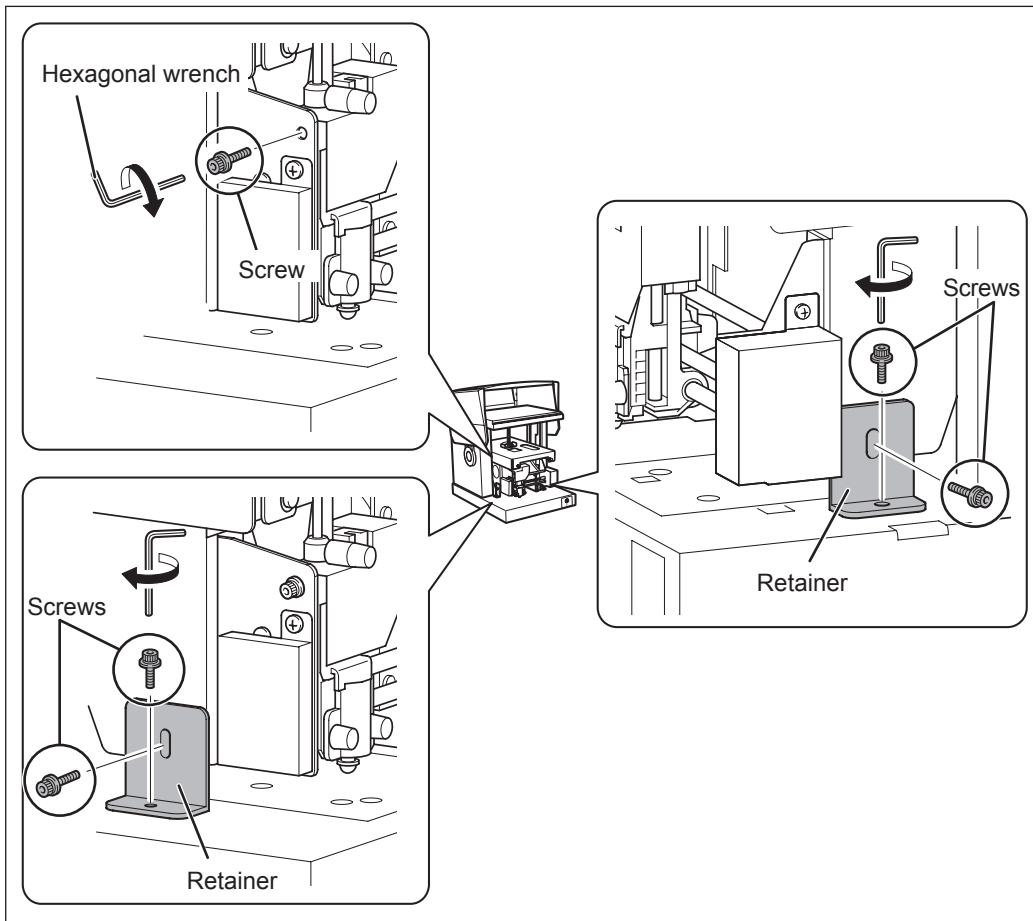

10

Close the cover and repack the machine in the original package.

6-3 Locations of the Power Rating and Serial Number Labels

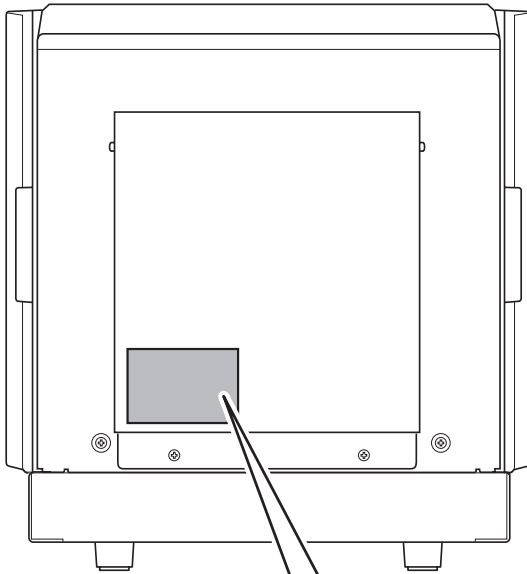

Serial Number

This is required when you seek maintenance, servicing, or support. Never peel off the label or let it get dirty.

Power Rating

Use an electrical outlet that meets the requirements for voltage, frequency, and amperage given here.

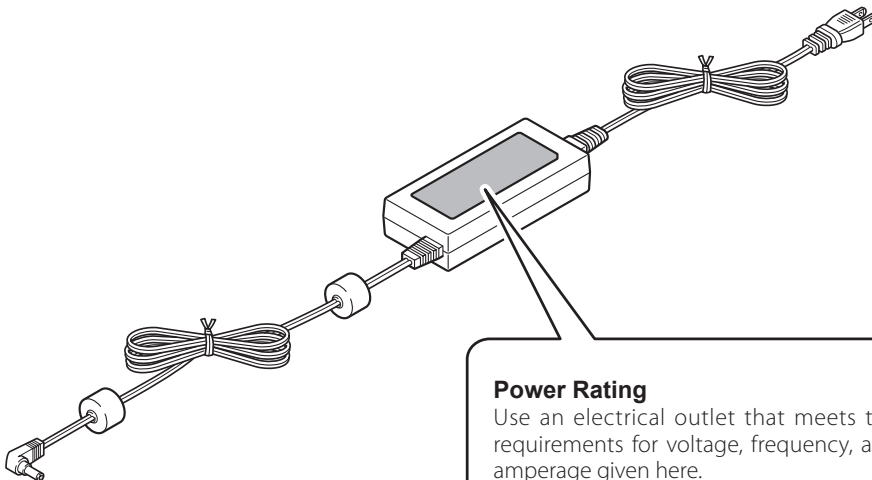

Power Rating

Use an electrical outlet that meets the requirements for voltage, frequency, and amperage given here.

6-4 Specification

Main Unit Specifications

		MPX-90
Printable material	Gold, silver, copper, platinum, brass, aluminium, iron, stainless steel, etc. (Vickers hardness [HV] of the printing surface must be 200 or less.)	
Loadable material size	Maximum 100 mm (width) x 200 mm (length) x 40 mm (thickness), or 200 mm (width) x 100 mm (length) x 40 mm (thickness) (3.9 in. x 7.9 in. x 1.5 in.), or (7.9 in. x 3.9 in. x 1.5 in.)	
Printing area	80 mm x 80 mm (3.1 in. x 3.1 in.)	
Resolution	529 dpi (High resolution), 353 dpi (Photo), 265 dpi (Text), 1058 dpi (Vector)	
Printing direction	Unidirectional printing or bidirectional printing (Selectable with Windows driver)	
Printing speed (Default)	50 mm/sec (1.9 in./sec) (Photo), 33 mm/sec (1.2 in./sec) (High resolution/Text), 24 mm/sec (0.94 in./sec) (Vector)	
Interface	USB interface (compliant with Universal Serial Bus Specification Revision 1.1)	
Power requirements	Dedicated AC adapter	AC 100V to 240V \pm 10% 50/60Hz
	Machine	DC 19V 1.6 A
Power consumption	Approx. 24W	
Acoustic noise level	Under 70 dB (A)	
Operation temperature	10 to 30°C (50 to 86°F)	
Operation humidity	35 to 80% (no condensation)	
External dimensions	286 mm (W) x 383 mm (D) x 308 mm (H) (11.3 in. (W) x 15.1 in. (D) x 12.2 in. (H))	
Weight	10.8 kg (23.8 lb.)	
Accessories	AC adapter, power cord, test-use printing material, USB cable, CD-ROM, user's manual, etc.	

System Requirements for USB Connection

Computer	A model preinstalled with the 32- or 64-bit edition of Windows XP, Windows Vista, or Windows 7, or a model upgraded from the one preinstalled with Windows XP or any later operating system than Windows XP
USB cable	Use the included USB cable.

For China

产品中有毒有害物质或元素的名称及含量

部件名称	有毒有害物质或元素					
	铅(Pb)	汞(Hg)	镉(Cd)	六价铬 (Cr(VI))	多溴联苯 (PBB)	多溴二苯醚 (PBDE)
印刷电路板	×	○	×	○	○	○
头部	×	○	○	○	○	○
壳体、底架	×	○	○	○	○	○
电源	×	○	×	○	○	○
其他(电缆、附件等)	×	○	○	○	○	○

○：表示该有毒有害物质在该部件所有均质材料中的含量均在 GB/T26572-2011 标准规定的限量要求以下。
 ×：表示该有毒有害物质至少在该部件的某一均质材料中的含量超出 GB/T26572-2011 标准规定的限量要求。

环保使用期限



此标志适用于在中国国内销售的电子信息产品，表示环保使用期限的年数。所谓环保使用期限是指在自制造日起的规定期限内，产品中所含的有害物质不致引起环境污染，不会对人身、财产造成严重的不良影响。环保使用期限仅在遵照产品使用说明书，正确使用产品的条件下才有效。不当的使用，将会导致有害物质泄漏的危险。

For EU Countries



This product must be disposed of separately at your local waste recycling center. Do not dispose of in household waste bin.



Lever dit product in bij een lokaal afvalverzamelpunt. NIET met normaal huishoudelijk afval afvoeren.



Bitte führen Sie dieses Produkt separat Ihrer örtlichen Entsorgungsstelle zu. Bitte nicht mit dem normalen Hausmüll entsorgen.



Dette Produkt skal smides særskilt væk på den lokale affalds- og genbrugsstation. Må ikke smides ud sammen med almindeligt husholdningsaffald.



Ne jetez pas le produit avec vos ordures ménagères. Portez-le dans un centre recyclage des déchets.



Tätä tuotetta ei saa hävittää normaalien talousjätteiden mukana, vaan se on toimitettava ongelmajätteiden keräilypisteeseen hävitettäväksi.



Questo prodotto deve essere smaltito negli appositi contenitori per la raccolta differenziata, non buttare nel cestino dei rifiuti casalinghi.



Produkten måste kasseras separat på din lokala återvinningscentral. Släng inte produkten tillsammans med hushållssoporna.



Este producto debe devolverse al centro de reciclaje más cercano a su domicilio para su correcta eliminación. No lo tire a la basura.



Μην πετάξετε το αντικείμενο αυτό στο καλάθι των απορριμμάτων. Αφαιρέστε τις μπαταρίες και προσκομίστε το στο τοπικό κέντρο ανακύκλωσης.



Deite fora separadamente este produto no seu centro de reciclagem local. Não o deite fora no seu caixote do lixo.

Please read this Agreement before unpacking the media.

Software license agreement

Roland DG Corporation (hereinafter referred to as the "Company") shall grant you a non-transferable, nonexclusive right to use the Software supplied with this Agreement, on the condition that you agree to the following provisions. If you agree to the following provisions, you should unpack the media on which the Software is recorded, or simply click the button or other indicator that you agree to the following provisions. By doing so, this Agreement shall be concluded.

If you do not agree with the following provisions, do not unpack the media. Or, you can click the button or other indicator that you do not agree to the following provisions of this Agreement. In this case, a license is not granted and you cannot use the Software.

1. Definition

The "Software" includes the software program and related files supplied with this Agreement and the related software programs and files distributed through the Internet and other services.

2. Ownership

All the ownership, copyright and other intellectual property rights of the Software, trademark, and related documents shall belong to the Company.

3. Terms and conditions

- (1) You are authorized to use the Software on one computer.
- (2) You are allowed to create a backup copy of the Software.

The right to keep the Software and the backup copy of the Software continues to belong to the Company, but the right to the media on which the backup copy of the Software is recorded does not belong to the Company.

4. Forbidden items

- (1) This copy of the Software, or a backup copy of the Software, must not be used on multiple computers at the same time, on a network, the Internet, or on other computers through any other means of distribution.
- (2) The Software shall not be reverse engineered, decompiled or reverse assembled.
- (3) The rights to the Software cannot be transferred, assigned, lent, loaned or licensed to a third party in any case, regardless of whether this Agreement has been terminated or cancelled.

5. Termination

- (1) The Company can cancel this Agreement and require you to discontinue use of the Software if you breach any provision of this Agreement or if you infringe on the ownership, copyright, or other intellectual property rights of the Company.
- (2) This Agreement shall be automatically terminated when you stop using the Software.
- (3) If this Agreement is terminated or cancelled, you must return your copy of the Software to the Company, or discard it as soon as practicable, at your own expense.

6. Guarantee

- (1) The Company shall not guarantee that the quality or functionality of the Software will satisfy any purpose that you may have in mind.
- (2) The Company shall not accept any responsibility for the results obtained from using the Software.
- (3) The Company shall not accept any responsibility for any loss which might be caused as a result of your exercising the rights granted under this Agreement.
- (4) The specifications for the Software are subject to change without prior notice.

7. Governing Law

This Agreement shall be governed by the laws of Japan.



1000009716

R5-120608