

UNCLASSIFIED

MANHATTAN DISTRICT HISTORY ✓

BOOK IV - PILE PROJECT

64142

X - 10

**SECRET**

VOLUME 2 - RESEARCH

PART II - CLINTON LABORATORIES

2A

This volume reviewed  
for possible declassification  
The only classified information  
in this volume is the  
following

① page 2.2 - information  
marked in blue ink is  
Secret Restricted Data

② Photos identified as A-23,  
A-27 and A-42  
are Confidential Source  
Information

E. J. Thurin  
2-17-59

~~RESTRICTED~~



84142

MANHATTAN DISTRICT HISTORY

BOOK IV - PILE PROJECT

X-10

VOLUME 2 - RESEARCH

PART II - CLINTON LABORATORIES

CLASSIFICATION CANCELLED  
OR CHANGED TO-----  
BY AUTHORITY OF DOE/DPC  
JOHN W. HARTSOCK  
REVIEWED BY  
9/5/79  
DATE  
Earl Hodgen, D.D., 50-10.23, 10/6/08

~~RESTRICTED DATA~~  
This document contains restricted information as defined in the Atomic Energy Act of 1946.

31 December 1946



~~SECRET~~

## FOREWORD

Part II of Volume 2 of Book IV of the Manhattan District History presents a description of the design, construction, and operation of the Clinton Laboratories. This work is described as a part of Volume 2 because the work conducted at Clinton Laboratories was part of the research and development phases of the Pile Project. The research work performed at the Metallurgical Laboratory is described in Part I of this volume.

The data contained in this volume are based on the General Files of the District Office and those contained in the records of the Operations Office, Clinton Laboratories, together with the files of E. I. du Pont de Nemours Company, Wilmington, Delaware, and the University of Chicago, Chicago, Illinois. This history covers the period from the inception of the Manhattan District to 31 December 1946. The date 31 December 1946 has been selected because of its being the last day of operation prior to which the Atomic Energy Commission assumed responsibility for all duties and accountability of the Manhattan District.

The Summary contains an abstract of every main subject treated in the text and is keyed to the text in such a manner that paragraph numbers and headings in the summary correspond to the various sections in the text.

A number of appendices are attached to illustrate the text of the volume by means of maps, drawings, charts, tabulations and photographs. A separate Top Secret Appendix has been prepared to this volume in which production data are shown.

**SECRET**

Other phases of the history of the Pile Project are described in:

Book IV - Volume 1 - General Features

Book IV - Volume 3 - Design

Book IV - Volume 4 - Land Acquisition, HEW

Book IV - Volume 5 - Construction

Book IV - Volume 6 - Operation

31 December 1948

**SECRET**

MANHATTAN DISTRICT HISTORY

BOOK IV - PILE PROJECT

VOLUME 2 - RESEARCH

PART II - CLINTON LABORATORIES

TABLE OF CONTENTS

<u>Par. No.</u>		<u>Page No.</u>
	FOREWORD	
	SUMMARY	
	SECTION 1 - INTRODUCTION	
1-1	Objectives	1.1
1-2	Scope	1.1
1-3	Authorization	1.2
1-4	Location	1.2
	SECTION 2 - DESIGN AND CONSTRUCTION	
2-1	General	2.1
2-2	Negotiation of Contract	2.1
2-3	Contractual Arrangements	2.2
	a. Statement of Work	2.2
	b. Title to Property	2.3
	c. Cost of Work	2.3
2-4	Performance of Construction Contractor	2.3
	a. General	2.3
	b. Pile Facilities	2.3
	c. Chemical Processing Plant	2.4
	d. Training Facilities for Hanford	2.4
	e. Power and Communication Facilities	2.5
	f. General Service Facilities	2.5
	g. Process Area Service Facilities	2.6
	h. Subcontracts	2.6
	i. Procurement	2.7
2-5	Construction Delays	2.7
	a. Classified Construction	2.7
	b. Labor Shortage	2.8
	c. Labor Turnover	2.8
	d. Unusually High Rainfall	2.8
2-6	Emergency Additions	2.9
2-7	Cost	2.10

**SECTION 3 - OPERATION OF CLINTON  
LABORATORIES**

3-1	Selection of Operating Contractor	3.1
	a. General	3.1
	b. Negotiation of Original Contract	3.2
3-2	Contractual Arrangements	3.2
	a. Statement of Work	3.2
	b. Title to Property	3.3
	c. Cost of Work	3.3
3-3	Performance of Contractor	3.3
	a. General	3.3
	b. Health Program	3.4
	c. Safety Program	3.4
	d. Intelligence and Security Program	3.4
	e. Personnel	3.5
3-4	Contractual Changeover	3.5
3-5	Cost of Operation	3.6

**SECTION 4 - PRODUCTION OF PLUTONIUM**

4-1	General	4.1
4-2	Description of Pile	4.2
	a. General	4.2
	b. Graphite Matrix	4.2
	c. Pile Shielding	4.3
	d. Pile Shielding Openings	4.4
	e. Cooling System	4.5
	f. Pile Controls	4.6
	g. Slug Handling Facilities	4.6
4-3	Pile Start-Up	4.7
4-4	Increase of Operating Level	4.8
4-5	Interruptions of Operation	4.9
4-6	Completion of Work	4.10

**SECTION 5 - DEVELOPMENT OF A SEPARATION  
PROCESS**

5-1	General	5.1
5-2	Description of Facilities	5.2
	a. General	5.2
	b. Pilot Plant	5.2
5-3	Process Development	5.3
5-4	Final Tests and Recommendations	5.4
5-5	Development of Isolation Process	5.5
	a. General	5.5
	b. Method	5.5
5-6	Uranium Wastes	5.6
	a. Storage	5.6
	b. Recovery	5.6
5-7	Completion of Work	5.7

<u>Par. No.</u>		<u>Page No.</u>
5-8	Development of Alternate Process	5.7
5-9	Chemical Studies of Fission Products and Heavy Elements	5.8
	a. Studies of the Process of Fission	5.8
	b. Studies of the Chemistry of Plutonium	5.9
5-10	Radioisotopes	5.9
	a. Laboratory Expansion	5.10

**SECTION 6 - DESIGN AND OPERATING  
PROBLEMS**

6-1	General	6.1
6-2	Detection of Slug Swelling and Can Failure	6.1
	a. Tests Developed to Detect Jacket Failure	6.2
	b. Routine Testing	6.3
	c. Corrosion of Uranium Slugs	6.3
6-3	Pile Poisoning	6.4
6-4	Testing of Proposed Shield	6.5
6-5	Testing of Materials for Use in Hanford Piles	6.7

**SECTION 7 - TRAINING OF PERSONNEL**

7-1	General	7.1
7-2	Facilities	7.1
7-3	Personnel Trained	7.1
	a. University of Chicago Program	7.1
	b. Monsanto Chemical Company Program	7.2
7-4	Disposal of Equipment	7.3

**SECTION 8 - ORGANIZATION AND PERSONNEL**

8-1	Design and Construction	8.1
8-2	Operation	8.1
	a. Organisation	8.2
	b. Personnel	8.2
8-3	Corps of Engineers	8.3

APPENDIX A - MAPS, DRAWINGS, PHOTOGRAPHS, AND DESCRIPTIONS

APPENDIX B - CHARTS AND TABULATIONS

APPENDIX C - REFERENCES

APPENDIX D - GLOSSARY

INDEX



~~SECRET~~

SUMMARY

1. Introduction. - Clinton Laboratories was constructed and operated to provide isolated facilities for research and development work pertaining to the Pile Project; to provide a pilot plant for the Hanford Engineer Works; and to produce small quantities of plutonium. The accomplishment of these objectives involved the design, construction, and operation of a uranium-graphite Pile; the development of a process for the separation and isolation of plutonium; and the training of personnel for transfer to the Hanford Engineer Works; as well as research work of a general nature. A site of about 112 acres within the military reservation of the Clinton Engineer Works was chosen for the Clinton Laboratories.

2. Design and Construction. - By 1 January 1943, the Military Policy Committee had decided to construct an intermediate-sized plutonium-production plant at Clinton Engineer Works, Tennessee. E. I. du Pont de Nemours and Company, Inc., entered into a contract with the Manhattan District for the design and construction of this plant without profit to the company. All costs of the work and its administrative expenses were paid by the Government and all equipment, supplies, buildings, and patent rights were to become the property of the Government. The staff of the Metallurgical Laboratory was designated approving authority for all design features because of the reluctance of the du Pont Company to accept responsibility for the adequacy of the design.

Design of the Pile Area was begun on 15 January 1943, and

[REDACTED]

construction work on 1 February 1943. This area was turned over to the operating contractor on 16 October 1943. Construction work in the Separation Area, carried out along with construction of the Pile Area, was completed on 26 November 1943. In addition to these production facilities, a training area was constructed which consisted of one large building with the equipment and facilities necessary for the training program, and a number of buildings and facilities were constructed which were directly connected with the process areas or with the general administration of Clinton Laboratories. Electric power was furnished by the Tennessee Valley Authority under a contract based on construction and operating power estimates. During the construction period, the du Pont Company awarded ~~25~~<sup>26</sup> subcontracts in order to expedite construction and to utilize specialized labor and machinery whenever possible. In addition to the orders covering these subcontracts, approximately 6300 purchase orders for materials and equipment were placed by the du Pont Company. Procurement handled by the Manhattan District included concrete, crushed stone, gasoline, oil, tires, office furniture, and many other items. In spite of a number of delaying factors, completion dates were not excessively delayed.

During April 1946, emergency additions were started in an expansion program designed to house the inflow of operating, technical and academic personnel replacing the progressive loss of older scientific people and to cover the training school program. These additions included a new permanent Radioisotope Building, a permanent research laboratory, a steam plant, a heterogeneous Pile, and related structures.

[REDACTED]

By 31 December 1946, all additional construction had been completed, bringing the total construction cost to approximately \$13,041,000 (representing \$12,032,000 under Contract W-7412 eng-23, and \$1,009,000 on emergency additions).

3. Operation of Clinton Laboratories. - Since most of the research pertaining to the Pile Project had been conducted by the Metallurgical Laboratory at the University of Chicago, the University of Chicago was selected to operate the pilot plant at Oak Ridge, Tennessee. Although operated as a part of the Metallurgical Project, the pilot plant was, for security reasons, known as Clinton Laboratories. The contract between the University of Chicago and the Manhattan District provided that the work be carried out for no fee, but included the provisions that the University be relieved of responsibility in the defense of claims against it and that a flat sum be paid the University to cover administrative and general expenses. Operation of Clinton Laboratories was to include the development of a suitable technique for the production of plutonium, a training program for prospective Hanford personnel, and medical and biological research necessary to Project activities. The title of all property and work was to become the sole property of the Government.

The production unit went into operation on 4 November 1943, and plutonium was being delivered early in 1944. During the term of the contract, the plutonium production schedule was met; a separation and isolation technique was developed; and the general research was conducted to the satisfaction of the Government. Active health and safety programs were maintained at Clinton Laboratories for the protection of

~~SECRET~~

the operating personnel. Because of the classified nature of the operations, strict intelligence and security <sup>by</sup> check was made on all personnel. Group athletics, graded pay increases, and assistance on personal problems aided in maintaining high morale among the personnel.

On 1 July 1945, operation of Clinton Engineer Works passed to the Monsanto Chemical Company, to be carried on largely in the same vein as operation under the University of Chicago. The new contract included the assumption of all liabilities, claims and obligations incurred under the Chicago group at the same time Monsanto took over all facilities, supplies and equipment.

To 31 December 1946 operational costs amounted to \$22,250,000, \$12,325,000 of which covered the Chicago operation from 1 March 1943 to 30 June 1945, while \$9,925,000 represented the costs under Monsanto leadership from 1 July 1945 to 31 December 1946.

4. Production of Plutonium. - One of the primary objectives of the operation of Clinton Laboratories was the production of a small quantity of plutonium in the shortest possible time. To accomplish this objective, an air-cooled, uranium-graphite Pile of 1000-kilowatt capacity was designed and constructed at Clinton Laboratories. The Pile consists essentially of a 24-foot cube of graphite blocks. Metal channels traverse the Pile from front to rear in 36 horizontal rows of 35 holes each. A removable core permits variation of channel spacing for lattice dimension experiments. A seven-foot thickness of laminated concrete shielding completely surrounds the Pile to reduce the radiations generated during operation to safe limits before they reach the working areas. The Pile and its shielding are equipped with

[REDACTED]

a number of openings, in addition to the 1260 metal channels. Openings are provided for safety and control rods, ionization chambers, and foils, as well as for experimental purposes. The openings through the shielding require specially designed plugs for closures during Pile operation to prevent direct emission of radiation.

The heat generated in the Pile is removed by a flow of cooling air which is then exhausted to a 200-foot stack. The cooling system was originally equipped with three fans: one 5000-cubic-foot-per-minute, stand-by, steam-driven fan; and two 30,000-cubic-foot-per-minute, electrically driven fans. Pile controls consist of shim rods, to shut the Pile down in an emergency and to compensate for large variations in operating conditions; control rods, to effect fine control of the Pile reaction; safety rods, to shut the Pile down very rapidly in an emergency; and safety tubes for boron-steel shot, to stop the reaction in the event that other control methods have failed. As slugs are charged into the Pile, irradiated slugs are forced out at the rear face, falling onto a mattress pad and sliding through water into a bucket in the discharge pit. The buckets are stored in a trench connected to this pit and later transferred to the Separation Building through a canal from the end of the storage trench. The start-up of the Clinton Laboratories Pile, delayed somewhat as the result of changes made in the metal channels, took place on 4 November 1943 and within a few days a level of 500 kilowatts was attained. Increases in the operating level were brought about by changing the lattice arrangement, by increasing the efficiency of the cooling system, and by using slugs with improved arc-welded jackets, so that,

~~SECRET~~

in May 1944, the Pile was operating at a level of 1800 kilowatts. Finally, the installation of larger fans in the cooling system permitted a further increase to 4000 kilowatts. No serious difficulties were encountered in Pile operation, although fan failure and fan-bearing troubles caused a few interruptions. In spite of these interruptions, the performance of the Clinton Laboratories Pile was very satisfactory in all respects.

Plutonium was being delivered by 1 February 1944 and the Pile continued to operate for the purpose of producing plutonium until 1 December 1944, by which time the experimental requirements were satisfied. After that date, the Pile was operated for the purpose of producing other radioactive material for the Project's research program.

5. Development of a Separation Process. - Another of the objectives of Clinton Laboratories was the development of a workable, reliable process for the separation of plutonium from the uranium and fission products. A precipitation method (Bismuth Phosphate Process) was selected for the Hanford plant and the activities of the Clinton Laboratories staff were directed toward proving this process under plant conditions, establishing the reproducibility of optimum process conditions, and testing alternate processes. Initial process development was accomplished by laboratory-scale tests. A small semi-works for process development and a pilot plant were then operated concurrently at Clinton Laboratories. The pilot plant consisted of six cells containing the process equipment, separated from each other and from the control room by thick concrete walls. All operations within

~~SECRET~~

the cells were remotely controlled from panel boards in the control room because of the high radiation levels throughout the process. Active wastes were held in underground tanks until proper disposition could be made. Gaseous wastes were exhausted to a 200-foot stack. The first batch of slugs was received for processing on 20 December 1943, and plutonium was being delivered early in 1944. Process efficiency was improved considerably during 1944—the factors affecting plutonium carrying were determined; the decontamination factor was increased; and the production yields were improved. Although these improvements were accomplished by process and equipment modifications, no basic changes in the process were required. Runs were made simulating Hanford conditions, which, with laboratory and semi-works runs, furnished a basis for predicting Hanford operating conditions. Final tests on the separation process were performed in August and November of 1944. During the operating period, 299 batches of slugs were processed in the Separation Building, with an over-all yield of 90.5 per cent. In January 1945, the equipment and cells were decontaminated and the pilot plant was placed in a stand-by condition.

It was necessary to develop a process for the isolation of plutonium in a pure, usable form. Based on the information gained by processing 37 batches of solution from the Separation Building, an isolation method, employing a precipitation, solution, and reprecipitation of plutonium peroxide, was developed. Development of a process for the recovery of the uranium from the solutions held in the six underground storage tanks was begun in the fall of 1944. Work on this problem was limited to the development of a process to

~~SECRET~~

be used at some future date. A group of chemists was assigned the task of developing an alternate separation process in the event of failure of the precipitation process. A feasible adsorption process was established but was not developed because, by June 1944, the Bismuth Phosphate Process had been proved adequate for use at Hanford. Chemical research, of secondary importance during the initial operating period, was begun in September 1943. Studies of the process of fission and of the chemistry of plutonium were instrumental in improving the separation process and the handling of the isolated plutonium.

Following the end of hostilities, a great part of the research program was directed toward peacetime uses of the various piles. Radioisotopes which were developed in this new angle of the Atomic Energy Program were to be used in the fundamental and applied sciences, particularly biological and medical. The distribution program was inaugurated in June 1946, at which time expansion of Hot Laboratory #706-C was in progress, and delivery (of Carbon 14) was made to the Bernard Free Skin and Cancer Hospital for "tagging" of cancer producing molecules and resulting study of the cancer problem. By 31 December 1946 shipments of radioisotopes totaled 125, sales value \$29,800.00.

6. Design and Operating Problems. - During the design of the large-scale production units, it was necessary to test the effectiveness of the shielding to be used at Hanford as well as a number of the materials to be used in the Pile itself. Two shield tests were made, one using an imperforate section, the other a perforate section, both of which indicated that the proposed shielding would be adequate for

~~SECRET~~



**SECRET**

use at Hanford. A number of ordinary construction materials and other materials which might be placed within the Hanford Piles were subjected to radiation in the Clinton Pile to determine the effects of radiation on their physical properties. The materials were irradiated for several weeks and the decay of the induced activities followed on Geiger counters.

The operating problems were concerned, for the most part, with slug testing and with the poisoning effect of fission products in Pile operation. Slug tests were accomplished by a variety of methods. The main methods used were a heat test in the presence of air and a deflection test. The susceptibility of the aluminum cans to corrosion under Pile conditions was investigated and the results indicated that corrosion under radiation would not be appreciably greater than that observed where there is no radiation. The poisoning effect of fission products was studied and no serious difficulties were anticipated in this respect. However, xenon poisoning of the Hanford Piles, encountered shortly after start-up, necessitated intensive study before a method of operation was developed which overcame this difficulty.

7. Training of Personnel. - Clinton Laboratories, both under direction of the University of Chicago and later the Monsanto Chemical Company, organized and operated a training school for its own personnel, trainees devoting time to operation of pilot plant facilities in addition to regular classroom work. In addition, the school, under the University of Chicago, trained two groups of du Pont employees for transfer to Hanford Engineer Works as a nucleus for its operating personnel. The school under Monsanto operation trained technical

**SECRET**

[REDACTED]

personnel in fields of nuclear science.

8. Organization and Personnel. - Clinton Laboratories was designed and constructed by the du Pont Company. The Design Project Manager for the TNX Section was H. T. Daniels. Construction was performed under the direct supervision of W. Irwin, District Superintendent for Clinton Laboratories, and J. D. Wilson, Field Project Manager.

Clinton Laboratories, under M. D. Whitaker, Director, was operated as a part of the Metallurgical Project. The operating organization consisted of 236 persons in August 1943; reached a maximum of 1513 persons in June 1944; and became stabilized at approximately 1300 persons by the end of 1944. A total of 113 technically trained men of the Special Engineer Detachment were assigned to Clinton Laboratories in order to overcome the scarcity of qualified technical personnel. Upon assumption of Clinton operation by Monsanto Chemical Company, Dr. Whitaker remained as director until 1 June 1946, at which time he resigned and was replaced by a co-directorship consisting of Dr. James H. Lum as Executive Director and Dr. Eugene P. Wigner as Director of Research.

The Corps of Engineers maintained only a small staff at Clinton Laboratories because the District Engineer's Office was located only a few miles away. This staff was headed by Major E. J. Murphy, Operations Officer.

**MANHATTAN DISTRICT HISTORY**

**BOOK IV - PILE PROJECT**

**VOLUME 2 - RESEARCH**

**PART II - CLINTON LABORATORIES**

**SECTION 1 - INTRODUCTION**

1-1. Objectives. - The objectives of the construction and operation of the Clinton Laboratories were: first, to provide isolated facilities for research and development work, supplementing the facilities of the Metallurgical Laboratory at the University of Chicago; second, to provide a pilot plant for as many parts of the processes to be used at the Hanford Engineer Works as the time schedule would permit; and third, to produce the small quantities of plutonium necessary for the research program.

1-2. Scope. - The scope of the work to be carried out at the Clinton Laboratories included:

1. The design, construction, and operation of an intermediate-sized uranium-graphite Pile for the production of plutonium.
2. Research and development toward a chemical process which could be used at the Hanford Engineer Works for the separation and isolation of plutonium from uranium and the radioactive by-products.
3. The organization and operation of a technical training school for the training of personnel for ultimate assignment to the Hanford Engineer Works.

~~SECRET~~

4. Chemical, physical, biological, and medical research and investigations of a general nature having a direct bearing on the Pile Project.

1-3. Authorization.

a. All action in connection with the institution and prosecution of this project was taken under authority granted by Congress in the Acts which are described in another book (Book I); the funds used were likewise appropriated by Acts there described.

b. Under the authority vested in him by these Acts, the President issued orders and authorizations which are described in the same book (Book I).

c. Major General L. R. Groves directed or authorized the general policies and directives under which the Manhattan District carried out the work. The S-1 Committee of the OSRD and the Military Policy Committee registered their general approval of the basic decisions involved, as recorded in the minutes of meetings or in other documents in the project files. (Book III, Appendix D1; See also Section 6, Organization and Personnel).

1-4. Location. - The site selected for the location of the Clinton Laboratories facilities was a tract of land of about 112 acres, situated in the northeast part of Roane County, Tennessee, lying in the Bethel Valley between Haw and Chestnut Ridges along the southwest border of the military reservation of the Clinton Engineer Works. (See App. A1). This site provided the isolation from centers of population required for the conduction of the research work, but was close enough to the cities of Knoxville, Clinton, Oak Ridge, Lenoir City, and Harriman,

~~SECRET~~

~~SECRET~~

Tennessee, to provide adequate living quarters for the personnel engaged in the work.

[REDACTED]

## SECTION 2 - DESIGN AND CONSTRUCTION

2-1. General. - By the first of January 1943, a decision had been made by the Military Policy Committee, acting on the recommendations of the Director of the Metallurgical Laboratory at the University of Chicago, to construct an intermediate-sized, plutonium-production plant at Clinton Engineer Works, Tennessee. E. I. du Pont de Nemours and Company, Inc., agreed to undertake the design and construction of the semi-works and pilot plant, to be known as the Clinton Laboratories, at the Tennessee location, as well as the design, construction, and operation of the large-scale, plutonium-production plant at the Hanford Engineer Works. The operation of the Clinton Laboratories facilities, however, was to be undertaken by the Metallurgical Laboratory, because of its close connection with the fundamental research, and because the Clinton facilities were to be used for development of design data and of processes, as well as for production of plutonium. The operation was covered by a separate contract, No. W-7405 eng-39, between the Manhattan District and the Metallurgical Laboratory, which became effective on 1 May 1943 (See Sec. 3).

2-2. Negotiation of Contract. - The du Pont Company, in accepting the undertaking, suggested that the work be conducted without profit and without patent rights of any kind accruing to them. However, the du Pont Company did request that maximum protection against losses be provided by the Government. It was agreed that a contract on a cost-plus-fixed-fee basis would be entered into and that the fixed fee would be one dollar. Accordingly, a contract, No. W-7412

eng-23, was awarded, by the Manhattan District, to the du Pont Company for the design and construction of Clinton Laboratories (See App. C 1).

2-3. Contractual Arrangements.

a. Statement of Work. - The specific responsibilities of the du Pont Company were to design and construct a small-scale plutonium production plant at the Tennessee site. The proposed plant was necessarily a translation of laboratory information into a production plant, with the operation of a unit less than one-thousandth of the proposed capacity (See Vol. 2, Part 1) as the only available practical demonstration of the basic production process. Thus, with no successful precedent to guide the design, the du Pont Company was reluctant to accept the responsibility for the adequacy of the design of this plant, and the staff of the Metallurgical Laboratory was designated as the approving authority for all design features. The proposed plant was to consist of an air-cooled, uranium-graphite Pile for the production of plutonium; a chemical processing plant for the separation of plutonium from the uranium and fission by-products; chemical, physical, biological, and medical laboratories; and other auxiliary administrative and service buildings and areas which were required because of the isolation of the plant from ordinary commercial facilities. It was agreed that the physical plant would be occupied by the personnel of the Metallurgical Laboratory prior to actual completion in order that operation could begin at the earliest possible moment, and that the du Pont Company would lend a large number of key technical personnel to the Metallurgical Laboratory in order to supplement its staff with men having the industrial experience necessary for the operation of the Clinton plant,

as well as to train these men for future service at Hanford.

b. Title to Property. - It was agreed that title to all equipment, supplies, buildings, and areas, and patent rights on processes and equipment, would become the property of the Government.

c. Cost of Work. - The Government agreed to pay all costs of the work by direct reimbursement or through monthly allowances provided by the contract to cover administrative and general expenses allocated to the work in accordance with normal du Pont accounting practices. Under the terms of the contract, any portion of these allowances not actually expended by du Pont were to be returned to the Government.

2-4. Performance of Construction Contractor.

a. General. - Although the Wilmington Office of the du Pont Company was responsible for the actual design of all of the facilities at Clinton Laboratories, the responsibility for the adequacy of such design was that of the staff of the Metallurgical Laboratory, who approved all drawings in their final form. The Clinton Laboratories was constructed by the du Pont Company and subcontractors in 1943 and 1944. In spite of such delaying factors as classified construction, the acute labor shortage, high labor turnover, unusually high rainfall, and the ever-changing requirements dictated by research results, completion dates were not excessively delayed for most of the construction. By March 1944, all buildings and facilities were accepted as complete by the operating contractor and by the Government (See App. A 2, 23).

b. Pile Facilities. - Design of the facilities in the Pile (100) Area at Clinton Laboratories was initiated by the du Pont Design



~~CONFIDENTIAL~~

Division on 15 January 1943. This area consists of the Pile (105) Building which contains the uranium-graphite Pile and associated equipment, the Exhauster (115) Building, the Area Shop (101) Building, the Uranium Storage Vault (103) Building, and the Instrument Storage (102) Building, as well as other facilities closely associated with the production unit (See App. A 2). Actual construction work was begun in the field on 1 February 1943, and the work had progressed to such a stage that the Pile Area (See App. A 24-32) was turned over to the personnel of the Metallurgical Laboratory for test operations on 16 October 1943.

c. Chemical Processing Plant. - Design and construction of the Separation (200) Area were carried out along with the design and construction of the buildings and facilities of the Pile Area. This area contains the Separation (205) Building, the Waste Storage (206) Area, and associated equipment and facilities (See App. A 2). An underground water canal and walkway provides a safe means for transporting the highly radioactive material from the Pile Building to the Separation Building. Construction in the Separation Area (See App. A 24, 27, 32-35) was completed and the area turned over to the operating groups on 26 November 1943.

d. Training Facilities for Hanford. - The 300 Area at Clinton Laboratories was constructed to serve as a training facility for personnel to be assigned to the Hanford Engineer Works. This area, consisting of one large building (Building 305), together with the equipment and service facilities necessary for the training program, was kept separate from all other work at Clinton Laboratories under

a separate Project number.

e. Power and Communication Facilities. - Because of the isolation of the site from centers of population, it was necessary to provide adequate electrical and communication facilities to the area. Electrical power for this part of Tennessee was supplied by the Tennessee Valley Authority from its immediate feeders at Norris, Watts Bar, and Fort Loudon hydroelectric plants. Power requirements for construction were estimated by the du Pont Company to be about 300 kilowatts, and the operating requirements were estimated by the Metallurgical Laboratory to be at least 350 kilowatts initially, and perhaps 5000 kilowatts as the work expanded. On this basis a separate contract was negotiated with the Tennessee Valley Authority to furnish temporary power for use in both the construction and operation of the Clinton Laboratories (See App. C 2). The facilities provided consisted of outside electric power supply lines and four substations. In addition to the power facilities, it was necessary to provide telephone and teletype service to the area. Tie lines to the Southern Bell Telephone Company and the Western Union and Postal Telegraph Company, and adequate switchboards were installed early in 1943. Automatic dial telephone equipment was placed in operation during March 1944.

f. General Service Facilities. - It was necessary to construct adequate general service facilities for the area. Because of the isolation of the site, separate water, steam, and sewage systems had to be provided (See App. A 36-41). The Layne Central Company of Memphis, Tennessee, was awarded a subcontract (See App. B 1), in February 1943, for drilling a well for drinking water. Upon completion, however, the

[REDACTED]

well water was found to be bacteriologically unfit for drinking purposes. Consequently, it was necessary to continue hauling drinking water by tank truck from Clinton, Tennessee, about twenty miles away, until the river pumping and purification systems were put into operation in July 1943. A septic system was installed, early in 1943, for sewage treatment; and a steam plant with two boilers, each rated at 530 horsepower, was constructed in 1943. Other general service facilities include roads, walks, fences, drainage ditches, guard towers, a parking lot, and air lines.

g. Process Area Service Facilities. - The 700 Area consisted of twenty-five service buildings and facilities, seven of which are directly connected with the process areas, and the balance with the general administration of the area (See App. A 2). The buildings associated with the process areas include the Chemistry Laboratory (706A) Building, Physics Laboratory (706B) Building, and the "Hot" Laboratory (706C) Building for experimentation with highly radioactive materials (See App. A 42-45). The buildings serving administration include the Main Administration (703A) Building, together with a shop and supply building, a laundry, a cafeteria, a machine shop, first aid facilities, and patrol headquarters and fire stations.

h. Subcontracts. - The awarding of subcontracts by the du Pont Company for certain phases of the construction work for this project was initiated for the following reasons: to expedite construction; to obtain labor and supervision specialized in some particular type of work; to eliminate purchase of special machinery and equipment needed only for a short period of time; to secure the very

[REDACTED]

best workmanship in the fabrication of material and equipment; to make use of extensive organization and personnel of specialized contractors; and to obtain use of patent rights required by design. A total of 26 subcontracts were awarded by the du Pont Company to various contractors for the construction of Clinton Laboratories (See App. B 1). These subcontracts were placed on a cost-plus-fixed-fee basis or on a lump sum basis. Eleven of these subcontracts, covered by half number purchase orders, were negotiated by the Wilmington Office of the du Pont Company and the balance, covered by whole number orders, were negotiated and awarded by the Contractor's Field Office with the approval of the Wilmington Office and the Area Engineer.

1. Procurement. - In general, procurement was handled by both the du Pont Company and the Government. The Wilmington Office of the du Pont Company placed some 1300 purchase orders for materials and equipment, which could most efficiently and most economically be obtained through their existing purchasing department at Wilmington. The du Pont Field Office placed over 5000 purchase orders for general building materials and equipment, with the approval of the Wilmington Office. The Government negotiated direct contracts with other firms furnishing the Prime Contractor with ready-mixed concrete, crushed stone, gasoline, oil, tires, tubes, and many other items. The Government furnished the special uranium metal for use by the operating contractor (See Book VII), as well as much office furniture and equipment and general materials.

2-5. Construction Delays.

a. Classified Construction. - The necessarily rigid

[REDACTED]

security regulations connected with the design and construction of these facilities did, in some ways, delay construction, but in spite of these regulations all construction was completed in time for the operations contractor to take over at the most opportune time.

b. Labor Shortage. - Construction of Clinton Laboratories was delayed to quite an appreciable extent by an acute shortage of both common and skilled labor. During the summer of 1943 it was necessary to reschedule a considerable portion of the construction work because the available labor force was capable of performing only three-fourths of the work originally scheduled. It was also necessary for the Prime Contractor to recruit labor directly, in addition to the recruiting efforts of the War Manpower Commission.

c. Labor Turnover. - In order to lower the labor turnover rate, which was rather high during the early period of construction, twenty-three special buses were subsidized by the du Pont Company for the transportation of workers to the site. Although the city of Oak Ridge, Tennessee, which was to furnish housing facilities for workers at the site was in the process of construction (See Book I, Vol. 12), it became necessary for the Prime Contractor to set up barracks for common laborers in an abandoned schoolhouse near the site in order to secure enough labor for the job. Special personal considerations were also given the employees in an attempt to increase their morale, and the combination of all these positive steps aided materially in reducing the labor turnover rate to a very reasonable value.

d. Unusually High Rainfall. - Unusually heavy precipitation resulted in slowing down the construction at the site during the

[REDACTED]

summer of 1943. The actual precipitation during the month of July 1943 was 9.3 inches, as compared to the normal average for July of only 4.3 inches.

2-6. Emergency Additions. - Construction (cost-plus-fixed-fee) Contract W-31-109-eng-39 was negotiated during April 1946, with the J. A. Jones Construction Company of Charlotte, North Carolina. John Davidson (vice-president) and W. A. Cone (project manager) were assigned to management. This contractor was just completing work in the K-25 Area of the Clinton Engineer Works and had personnel, equipment, and materials available for immediate commencement of the work. The need for immediate additional facilities (expansion of existing temporary plant) was occasioned by a large and sudden inflow of operating, technical and academic personnel as replacement for progressive loss of older key scientific people and for training school enrollment. The uncertain future of the Laboratories was relieved somewhat by an announcement covering a switch from wartime to peacetime planning for the application of Nuclear Energy. Press releases were given at this time relative to the Power Pile and Radioisotope development program. The architect-engineer firm of Holabird and Root under subcontracts to the prime operating contract began design of a new permanent Radioisotope Building, along with a site plan study for a permanent research laboratory. Subcontract negotiations began in March 1946. During November 1946, work began under an architect-engineer subcontract, between Monsanto and the Kellogg Corporation of New York City for the design of a steam plant and a heterogeneous pile and related structures. Consultant subcontracts with organizations and individuals totaled 44

in number.

2-7. Cost (See App. B 2-4). - The total cost of design and construction of the Clinton Laboratories, as of 31 December 1946, under Contract W-7412 eng-23, was approximately \$12,032,000, of which \$5,912,000 was spent for labor and \$6,120,000 for materials and equipment. A breakdown of this cost indicates that the total construction cost for the Pile (100) Area was \$3,955,000, of which \$1,639,000 was spent for labor and \$2,316,000 for materials. The cost of design (included in the above) of this area was approximately \$121,950. The total construction cost for the Separation (200) Area was about \$2,168,000, \$1,062,000 being expended on labor and \$1,106,000 on materials. The design cost of the Separation Area was approximately \$66,850 (included above). Construction cost for the Training School was \$311,000, of which total approximately \$10,000 was spent on design. Power and communications facilities were designed and constructed at a total cost of approximately \$163,000, of which the design cost was about \$5,000. Design and construction costs for the general service facilities amounted to \$4,316,000, approximately \$133,000 of which represents design costs. Process Area service facilities were designed and constructed for a total of \$1,119,000. The design cost of these facilities was about \$53,000.

The cost of making emergency additions to practically all of the original temporary structures, undertaken by the J. A. Jones Construction Company, Inc., in April 1946, amounted to about \$1,009,000 by 31 December 1946. The amount spent on labor was about \$754,000 while material charges were listed at \$255,000.



SECTION 3 - OPERATION OF CLINTON LABORATORIES

3-1. Selection of Original Operating Contractor.

a. General. - The accomplishment of the Clinton Laboratories objectives involved research and development work in a scientific field in which the total knowledge, early in 1943, was limited to the results of theoretical calculations and of a few small-scale experiments. The very character of the work imposed severe limitations on the number of contractors from which the selection of an operating contractor could be made. The du Pont Company, which designed and constructed the Clinton Laboratories, was considered qualified to perform the operating functions but was not selected because of other heavy war commitments, one of which was the design, construction, and operation of the large-scale plutonium-production plant at the Hanford Engineer Works, and because of the inadvisability of having one contractor responsible for the execution of the entire Pile Project. Since most of the plutonium research studies and investigations performed under the supervision of the Office of Scientific Research and Development had been conducted by the Metallurgical Laboratory at the University of Chicago (See Vol. 2, Part I), it was obvious that, although no organization possessed complete experience or special information in the field involved, the University of Chicago was best fitted to operate the Clinton Laboratories. Although the pilot plant was to be operated as a part of the Metallurgical Project, it was not desirable, for reasons of security, to have the University of Chicago's name associated with the work to be performed at the Clinton Engineer Works. Thus, the organization known



~~SECRET~~

as Clinton Laboratories was formed and, although not incorporated, it functioned as a corporation with the permission of the State of Tennessee.

b. Negotiation of Original Contract. - The University of Chicago agreed at the outset of negotiations to enter into a contract to carry out the program at Clinton Laboratories for no fee. Because of the unusual nature of the work and the unpredictable results of experimentation, however, it was suggested that provision be made in the contract to relieve the University of responsibility in the defense of claims against it, resulting from actions or omissions in the performance of the work, whereby the Government would discharge all final judgments entered against the contractor. Assumption of these obligations by the Government was approved and authorized by the President of the United States, under the powers conferred upon him by the First War Powers Act of 1941, and was included in the terms of Contract No. W-7405-eng-39 (See App. C 3). Also included in the contract was the provision that a flat sum, equal to twenty per cent of the total direct wages and salaries, and in no event less than \$30,500 per month, be paid directly to the University of Chicago to cover administrative and other expenses not otherwise reimbursable under the general terms of the contract.

3-2. Contractual Arrangements.

a. Statement of Work. - Under the terms of the contract, the University of Chicago was to conduct such research, experimental, and development work as was necessary to develop a manufacturing technique for the production of plutonium in small quantities. The

[REDACTED]

pilot plant at Clinton Laboratories was to be operated, in addition, for the purpose of carrying out a training program for personnel who would eventually be transferred to the Hanford Engineer Works. Finally, such medical and biological research as was deemed necessary for Project activities was to be carried out subject to the approval of the Contracting Officer.

b. Title to Property. - All materials, tools, machinery, equipment and supplies, as well as all data and notes concerning the design, construction, and development of the process and all patent rights were to become the sole property of the Government. Such property, however, was to remain in the custody of the contractor during the term of the contract for use in the performance of the work.

c. Cost of Work. - The University of Chicago was to be reimbursed for all actual and specific costs and expenses incurred in the performance of the work. Reimbursements were to be made by the Government upon presentation of vouchers or receipted invoices to the Contracting Officer. The total appropriation for the operation of the Clinton Laboratories from 1 March 1943 until 30 June 1944, as provided by the contract, was not to exceed \$6,650,000. Supplemental agreements, however, increased the amount to \$17,000,000 in order to cover the cost of the work when the term of the contract was extended from 30 June 1944 to 30 June 1945.

### 3-3. Performance of Original Contractor.

a. General. - Operating personnel arrived at Clinton Laboratories at the Clinton Engineer Works, in the spring and summer of 1943. Although construction work was not completed until about

~~TOP SECRET~~

March 1944, the production unit went into operation on 4 November 1943 and plutonium was being delivered as early as 1 February 1944. Throughout the year 1944 and the early part of 1945, Clinton Laboratories was able to meet the assigned schedule for plutonium production. Thus, during the period of the contract, a sufficient amount of plutonium was manufactured to satisfy all requirements for experimental work; a satisfactory separation and isolation technique was developed for use at the Hanford Engineer Works; and the general medical, chemical, physical, and biological research was conducted to the satisfaction of the Government.

b. Health Program (See Book I, Vol. 7). - A health program was established and maintained at Clinton Laboratories in order to provide for the health of the operating personnel. The unusual and unpredictable health hazards connected with much of the work made it necessary to maintain a strict check on personnel by means of periodic physical examinations and by limiting the working time in particularly hazardous areas.

c. Safety Program (See Book I, Vol 11). - An active safety program was maintained at Clinton Laboratories through safety lectures, posters, guides, and personal contact with all employees. The success of this program is indicated by the fact that Clinton Laboratories ranked high in the Manhattan District safety ratings which in turn compare very favorably with normal industrial ratings.

d. Intelligence and Security Program. - Operations at Clinton Laboratories were classified by the Manhattan District as "Secret," and in some special cases "Top Secret." These classifications

[REDACTED]

necessitated the establishment and maintenance of a strict intelligence and security check on all personnel, materials, and operations. The general Intelligence and Security Program of the Manhattan District (See Book I, Vol. 14) was followed by the University of Chicago at Clinton Laboratories.

e. Personnel. - In general the wage scales, hours of work, and working conditions for ordinary labor at Clinton Laboratories were in accordance with the over-all labor policies of the Manhattan District and with the Labor Relations Board directives. Efforts were made to maintain high morale among the employees through group athletics, graded pay increases, and assistance on housing (See Book I, Vol. 12), transportation, and other personal problems.

3-4. Contractual Changeover. - By letter of 1 May 1945, the Monsanto Chemical Company contracted to commence operation of Clinton Laboratories on 1 July 1945, under Contract W-35-058 eng-71, continuing operations theretofore carried on by the University of Chicago. The Government and the University, in mutual agreement, determined that it would be in the best interest of the Government to have this effort continued by the Monsanto Chemical Company which would assume all obligations, facilities, supplies, and equipment employed on this work by the University, provided it was owned by the Government. It was acknowledged that the Chicago group, having successfully accomplished their mission and assignment under Contract W-7405 eng-39 (see paragraphs 2 a and b) desired a return to the straight academic field, leaving this particular laboratory operation to a commercial organization known to be properly equipped for the task at hand. Since the

[REDACTED]

University had incurred certain claims, liabilities, obligations, and commitments, it was considered in the best interest of the Government to have them liquidated under the succeeding contract which was to be inside the scope of the original.

3-5. Cost of Operation. - The total cost of operating Clinton Laboratories under both contracts, by 31 December 1946, amounted to \$22,250,000. For Contract W-7405 eng-39 (1 March 1943 - 30 June 1945), this totalled \$12,325,000, of which \$6,842,000 was paid out in salaries, \$4,780,000 in general operating expenses, and \$703,000 had been received in materials and services furnished by the Government. The cost under Contract W-35-058 eng-71 (1 July 1945 - 31 December 1946) amounted to \$9,925,000.

## SECTION 4 - PRODUCTION OF PLUTONIUM

4-1. General. - One of the primary objectives of the work at Clinton Laboratories was the production of a small quantity of plutonium. Because the performance of many fundamental experiments having to do with the physical, chemical, and metallurgical properties of plutonium depended upon the early receipt of this material, it was extremely important that the relatively small quantities required be made available at the earliest possible date. In addition to the plutonium needed for the investigation and establishment of its properties, it was essential that enough be produced for use in the development of a process for the separation of plutonium from uranium and the radioactive fission products. With this objective in view, an air-cooled uranium-graphite Pile of 1000-kilowatt capacity was designed and constructed by the du Pont Company at Clinton Laboratories (See Par. 2-4), with the expectation that, after the Pile was tested and operated, changes could easily be effected whereby the rate of plutonium production could be increased. Since original plans for the large-scale Piles at Hanford pointed to the use of helium as a cooling medium, it was expected that the Clinton Pile would serve as a pilot plant for the larger installations. Although the plans for the main plant were changed to include water-cooled units (See Vol. 2, Part I), the pilot plant retained its air-cooled system in the belief that the production of the few grams of plutonium needed for experimental purposes would be accomplished more quickly if a change in design were avoided.



4-2. Description of Pile (See App. C 4).

a. General. - The Clinton Laboratories Pile consists essentially of a 24-foot cube of graphite blocks with (1) horizontal holes (for the uranium slugs) traversing the Pile from front to rear, and (2) holes (for control rods, safety rods, and experimental purposes) at right angles to the charging holes, both horizontally and vertically. Cooling air is drawn by fans through the charging holes, around the slugs, and exhausted up a stack. The nominal designed power output, or the rate of heat dissipation, is 1000 kilowatts, necessitating that the Pile be completely surrounded by concrete shielding to reduce the radiations generated at this level of operation to safe limits. All openings through the shielding which give access to the experimental and operating channels are equipped with plugs which are removed only when the power output is sufficiently low to prevent a dangerous amount of radiation from escaping through these openings.

b. Graphite Matrix (See App. A 3, 4). - The graphite is built up as a 24 by 24-foot square section, 24 feet-4 inches high, by 73 courses of 4-inch square graphite blocks of lengths varying from eight to fifty inches. Metal channels through the blocks are arranged on eight-inch centers at the face of the Pile, in 36 horizontal rows of 35 holes each. The channels are 1-3/4 inches square in cross section set on edge. The charging tubes, 1-1/4 inch standard pipe, extend two inches into the ends of the blocks at the front face of the Pile. On the rear face of the Pile, the top of each metal channel is cut in a rectangular opening to prevent possible

[REDACTED]

binding of the slugs at the top of the channel during discharge. A removable core, separately constructed and keyed as an integral unit, is provided to permit the trial of different spacings of metal channels for "lattice dimension experiments."\*

c. Pile Shielding (See App. A 4). - The Clinton Pile is completely surrounded by a seven-foot thickness of concrete shielding. The outside of the shielded Pile is approximately 47 feet long by 38 feet wide by 35 feet high. The shield on the front or charging face consists of seven laminations, the outside two of standard concrete, nine inches thick, inside of which are walls of three-inch precast standard concrete blocks to register the 1260 charging tubes on eight-inch centers; on the inside face of each precast block is a heavy, pitch coating used to prevent loss of water from the special Haydite-barytes concrete which forms the central five-foot lamination. The special concrete has the property of retaining permanently 10% or more of its weight of water when the density of the concrete is at least 150 pounds per cubic foot after curing; its use in the shield is the result of the effectiveness of the hydrogen in the water in stopping neutrons. The side and rear shields consist of five laminations: two 12-inch standard concrete outer walls, two layers of heavy pitch, and a five-foot central section of Haydite-barytes concrete. The roof slab also has five laminations: the bottom layer, consisting of 18 inches of standard reinforced concrete, has sufficient strength to support the superimposed load; following this layer are five feet of the special Haydite-barytes concrete, between two layers of pitch; the top layer consists of six inches of standard concrete.



[REDACTED]

d. Pile Shielding Openings (See App. A 5-8). - The front face of the Pile shielding has, in addition to the 1260 openings for the charging tubes, a large opening near the center which is closed by a concrete-filled steel plug to be used in connection with the 20-inch by 24-inch removable core. Each side wall contains 29 openings: two openings for regulating rods; four openings for shim rods; ten openings for experimental investigations, such as, measurement of neutron cross sections and production of radioactive materials; nine openings for the insertion of "foils"; and four openings for ionization chambers. The back wall contains an opening slightly larger than 20 inches by 24 inches to facilitate removal of the graphite core; this opening is surrounded by six holes arranged for experimental and observation purposes. The roof slab contains a vertical five-foot square opening which is centered on the graphite structure. This central opening is surrounded by six circular holes for safety rods. There are 35 vertical openings in the top of the Pile shielding (above the rear face of the Pile) for the insertion of a scanning mechanism which would permit a determination of the temperature and radioactivity of the air emerging from any metal channel. Two adjacent openings in the roof of the shielding, each equipped with an aluminum carriage and three lead gates, permit the insertion and withdrawal of animal cages during Pile operation. Because of the intensity of the radiation that escapes through even a very small space around any of the various openings in the Pile shielding, specially designed plugs are used as closures during Pile operation (See App. A 9). The openings consist of a series of steps resulting from diameter changes, forming

[REDACTED]

a labyrinth which is intended to reflect the radiation several times and thus prevent direct emission.

e. Cooling System. - The heat generated in the Pile is removed by a flow of cooling air (See App. A 10). The entire system is maintained under vacuum by fans which discharge the air from the Pile to a 200-foot stack. The cooling air is drawn into the Pile Building and filtered. The filtered air enters a concrete duct and flows around either side of a U-shaped baffle designed to prevent neutron and gamma radiations from reaching the filters. The air from the duct is drawn upward past the front face of the Pile, and, entering the metal channels through slots provided in each of the steel pipe charging tubes, is discharged at the rear face of the Pile. In addition to the air drawn through the Pile in this manner, approximately one per cent of the volume is drawn directly through the concrete shielding into the air chamber at the rear of the Pile in order to prevent excessive thermal expansion and loss of moisture from the Haydite-barytes concrete. Air from the discharge chamber is drawn through a concrete duct to the Fan House where, after passing through a series of U-bends, it goes through the fans and is discharged to the stack. Water spray nozzles in the stack and fan cells serve to wash away any radioactive dusts that may be deposited. The cooling system was originally equipped with three fans: one stand-by, steam-driven fan with a capacity of 5000 cubic feet per minute; and two electrically-driven fans each having a capacity of 30,000 cubic feet per minute. In July 1944, the latter were replaced by two electrically-driven fans each having a capacity of 70,000 cubic feet per minute (See App. A 46),

in order to increase the effectiveness of the Pile cooling system.

f. Pile Controls (See App. A 11-14). - In order to produce plutonium safely it is necessary that the Pile reaction be controlled at all times. To accomplish this control, the Clinton Laboratories Pile was provided with safety rods and tubes, regulating rods, and shim rods. Four 1.5-per-cent boron steel safety rods, 1-1/2 inches in diameter and eight feet long, are suspended above the Pile, operating vertically by gravity. These rods, operating either manually or automatically, are designed to shut the Pile down very rapidly in case of an emergency greater than can be handled effectively by the regulating and shim rods. Two vertical, empty, closed-end tubes are built into the Pile to receive a quantity of boron steel shot, normally held in containers outside the Pile and above the tubes. The shot can be released manually as a final effort (after other methods have failed) to stop the Pile reaction. Two horizontal 1.5-per-cent boron steel regulating rods, 1-3/4 inches square and 19 feet long, and coupled at their outer ends to steel racks 22 feet long, can be operated manually or automatically to effect fine control of the Pile reaction. These rods are normally used one at a time. Four shim rods, similar to the regulating rods, have two functions: first, to shut the Pile down when the need arises; second, to compensate for variations in operation which are too large to be handled by the regulating rods. The shim rods are normally operated manually but an automatic system is provided for complete insertion during an emergency. Manual operation of the Pile controls may be effected from the main control panel (See App. A 15, 47).

g. Slug Handling Facilities. - An elevator along the front

[REDACTED]

face of the Pile carries a pair of tracks for two charging machines (See App. A 48, 49). These machines charge the uranium, which is in the form of slugs approximately one inch in diameter and four inches long and jacketed with aluminum, into the Pile. As a new slug is pushed into the Pile, an irradiated slug is forced out at the rear face. The discharged slug falls freely downward onto one of two mattress pads and slides through water down a stainless steel chute into a stainless steel bucket in the discharge pit (See App. A 7). The discharge pit, which is approximately seven feet square and contains a 20-foot depth of water, is connected to a horizontal storage trench, approximately seven feet wide, 65 feet long, and nine feet deep. A canal for the transfer of slugs to the Separation Building runs from the end of this storage trench. A monorail crane carrying an electric hoist is located above the trench and canal to facilitate the movement and delivery of buckets.

4-3. Pile Start-Up. - The Clinton Laboratories Pile was charged with approximately 35 tons of uranium in the form of jacketed slugs and operations were begun on 4 November 1943. This start-up date was a few weeks later than the requested date as the result of changes made in the Pile metal channels, such as the chamfering of the ends of each graphite block in each channel and the cutting away of the tops of each channel at the rear Pile face. Although these changes delayed the start-up slightly, a net delay in the production schedule was undoubtedly avoided since the possibility of slugs becoming wedged in the channels was greatly lessened by these changes. Within a few days after the start-up, the Pile was brought to a power level of

500 kilowatts with a maximum slug surface temperature of 110 degrees Centigrade. In a short time, a power level of 800 kilowatts was attained by plugging some of the outer channels and through the use of a maximum slug surface temperature of 150 degrees Centigrade. During and after Pile start-up many fundamental investigations were carried on, such as: investigation of the change of period with Pile loading; temperature measurements and Pile power calibration; determination of a temperature coefficient for the Pile; calibration of control rods; observation of the reaction of the Pile to control rod movement; measurement of "neutron flux"; and determination of stack activity (See App. C 5).

4-4. Increase of Operating Level. - Although the operating level of the Pile was maintained at its rated value, engineering studies made during the early part of 1944 indicated that the operating level and, consequently, the rate of production of plutonium could be substantially increased by making a few rather minor changes. Whereas the Pile was previously operated with 459 channels loaded with 65 slugs each, in March 1944, a new loading, consisting of 709 channels with 44 slugs each, was adopted. This new loading method, designed to change the shape of the lattice arrangement, permitted a higher power output without attaining too high a temperature by reducing the amount of uranium near the center of the Pile relative to that farther out. The efficiency of the air cooling system was increased by the use of well designed plugs for checking the flow of air through channels which did not contain uranium. Finally, the use of slugs with improved arc-welded jackets permitted raising the temperature of the Pile so

TOP SECRET

that the hottest slugs had a surface temperature of 200 degrees Centigrade. As a result of these changes a power level of 1800 kilowatts was attained in May 1944. In June and July 1944, the installation of two large fans, each having a capacity of about 70,000 cubic feet per minute, permitted a further increase in the Pile power level. The combined effect of these changes made it possible to operate the Pile at a level of 4000 kilowatts, or four times the designed operating level, and brought about an appreciable increase in the rate of plutonium production.

4-5. Interruptions of Operation. - At no time were serious difficulties encountered in connection with the operation of the Pile proper. In ease of control, steadiness of operation, and production of plutonium, the Clinton Laboratories Pile was very satisfactory. There were no failures attributable to mistakes in design or construction -- a remarkable fact, considering that this plant was constructed without previous experience and was designed on the basis of the meager data available in 1942. Some interruptions were encountered in Pile operation, however, as a result of failures in the cooling system. In August 1944, one of the large fans failed, necessitating the installation of one of the old fans, having a capacity of 30,000 cubic feet per minute, while the large fan was being repaired. The fan was repaired and reinstalled in September of 1944. Fan-bearing trouble also resulted in interruption of operation during October and November of 1944. In order to reduce troubles of this nature a system for constant surveillance of the fan bearings was installed (See App. A 50). The schedule for production of plutonium was maintained in

~~TOP SECRET~~

spite of the operating difficulties mentioned above, and at no time, except in January 1944, was it behind that originally estimated. (See App. C 6 and special "Top Secret" Appendix to this book).

4-6. Completion of Work. - By 1 February 1944, three months after operations were begun, sufficient plutonium had been delivered to enable the most important experiments to be carried out. By 1 March 1944, several grams of plutonium had been delivered. The Pile was operated for the purpose of producing plutonium until January 1945, at which time sufficient plutonium had been produced (about 20 per cent more than originally estimated) to meet the experimental requirements (See special "Top Secret" Appendix to this book). After January 1945, the Pile was operated for the purpose of producing other radioactive materials, such as radioactive barium, zirconium, lanthanum, and antimony, for the research program at Hanford, Chicago, Los Alamos, and other requirements of the Manhattan District Project.

## SECTION 5 - DEVELOPMENT OF A SEPARATION PROCESS

5-1. General. - One of the main objectives of the Clinton Laboratories was the development and test, under plant conditions, of a workable and reliable process for the separation of plutonium from uranium and the number of highly radioactive by-products formed by the Pile Reaction. A number of methods for effecting this separation were proposed and investigated by the staff of the Metallurgical Laboratory at the University of Chicago; these could be classed in four general categories: precipitation processes, adsorption processes, solvent extraction processes, and a volatility process (See Vol. 2, Part I). Because of the progress made in the study of precipitation methods by June 1943, the time at which plant design was started, it was decided that these methods would be adopted for the Clinton and Hanford plants. Two precipitation processes, one using lanthanum fluoride as the carrier precipitate and the other using bismuth phosphate as the carrier, received a great deal of attention. Lanthanum fluoride was the more efficient carrier, carrying plutonium at a weight ratio of five parts of lanthanum fluoride to one part of plutonium fluoride as opposed to a ratio of 90 parts of bismuth phosphate to one part of plutonium phosphate, but corrosion tests indicated that a process utilizing bismuth phosphate would present fewer operating problems in a large-scale plant. The process finally chosen represented a combination of the two processes whereby bismuth phosphate was employed as the carrier in the extraction steps and lanthanum fluoride was used in the concentration and isolation steps. Thus the activities of the Clinton Laboratories



staff were directed towards:

1. Elaborating on and improving the separation process outlined by the Metallurgical Laboratory and proving this process under plant conditions.
2. Establishing the reproducibility of the optimum process conditions in order to permit predictions concerning Hanford operations.
3. Testing alternate processes in the event of difficulties encountered in the use of the process chosen for Hanford.
4. Studying the selected process from the standpoint of the chemical mechanisms involved to insure against failure during plant operation.

5-2. Description of Facilities.

a. General. - The initial development and testing of the separation process was done on a laboratory-scale by chemists at the University of Chicago and at Clinton Laboratories, working with standard chemical apparatus and techniques. With the success of the laboratory tests assured, a small semi-works was constructed at Clinton Laboratories as an intermediate step between the laboratory and the pilot plant (See App. A 42, 51). The semi-works was used for process development and operated concurrently with the pilot plant for the separation process.

b. Pilot Plant. - The Separation (205) Building contained six cells (See App. A 16), one for the dissolution of the irradiated uranium slugs; four for plutonium recovery and purification, and waste neutralization; and one (double size) for the storage of contaminated

[REDACTED]

equipment that had failed in operation. These cells, containing the process equipment, were separated from the control room and from one another by thick concrete walls which served to shield operating personnel from the radioactive emissions which accompanied the process. Because of the high radiation levels present throughout the process, remote control of operations was necessary; consequently, all operations within the cells were controlled from panel boards located in the control room (See App. A 17, 52, 53). In general, each of the cells used for plutonium recovery and purification contained a "precipitator", a centrifuge, a catch tank, and a neutralizer as well as the necessary process piping and drainage and waste systems (See App. A 18-20). Process wastes were led, through buried piping, to underground storage tanks (See App. A 21, 22) to be held until proper disposition of these wastes could be made. Cooling water used in the process was held in retention ponds for testing and dilution before discharge. Drainage from the floors of the cells was held in underground tanks for analysis; if the drainage was not too greatly contaminated, it was discharged through the retention ponds to White Oak Creek. A 200-foot stack was provided to exhaust the gaseous wastes to the atmosphere; a ventilation system supplied air for the dilution of the gases from the dissolver.

5-3. Process Development. - On 20 December 1943, the first batch of slugs from the Pile were received in the Separation Building for process. By the end of January 1944, uranium was being received at the rate of one-third of a ton per day and by 1 February 1944 the first output of plutonium had been delivered. With the success of the process

[REDACTED]

thus insured, considerable improvement in the efficiency of the process was achieved during 1944 by studies of its many variables. Problems arising during plant operation were studied in the semi-works and the results obtained were utilized as a basis for future operations. During this period, the efficiency of the carrying of plutonium was found to depend upon the rate at which the carrier was precipitated, the time of "digestion" following the precipitation, and the method used to form the carrier precipitate. As a result of the persistent development work in the laboratory and semi-works, the pilot plant decontamination factor (a factor indicating the degree of separation of the undesirable radioactive fission products from plutonium) was increased many thousandfold through the use of scavengers such as zirconium and cerium, and the production yields were increased from an initial value of 50 per cent to approximately 90 per cent, by the adoption of a series of washes following each precipitation and the installation of more efficient agitators in the solution tanks. Although no basic changes were required, process and equipment modifications were made whenever necessary to improve the efficiency of the process.

5.4. Final Tests and Recommendations. - With the most favorable conditions for pilot plant operation chosen, additional equipment was installed in the Separation Building so that the process could be carried out without re-using equipment for a number of steps. <sup>(See App. A-57)</sup> In this way operating conditions at Hanford were simulated as nearly as possible in the pilot plant. Test runs with this equipment furnished data which, together with the results of laboratory-scale runs and data from semi-works runs, using the concentration levels of plutonium

[REDACTED]

and inactive fission products to be encountered at Hanford, furnished a sound basis for predicting Hanford operating conditions. The final tests performed on full plant scale, for the purpose of developing and testing the separation process for use at Hanford, were completed in August 1944. A formal report was issued by the Clinton Laboratories on 1 October 1944, based on the results of these tests, recommending optimum operating conditions for Hanford (See App. C 7). Prior to the publication of this report, the pertinent details were made available to the interested personnel at Hanford, by means of informal progress reports and personal contact. Further tests, designed to improve the over-all process efficiency, were completed in November 1944 and the recommendations based upon their results were issued as a supplement to the above report. Upon the completion of the work in the Clinton Laboratories Separation Plant, the experimental data pertaining to the process were summarized in a report dated 20 July 1945 (See App. C 8).

5-5. Development of Isolation Process.

a. General. - Although the separation process was designed to separate the plutonium from the uranium and undesirable fission products, it did not offer a suitable means either of isolating the plutonium free from all impurities or of preparing the plutonium for shipment and use. It was necessary, therefore, to develop a process by which the plutonium could be isolated in a usable form free from all metallic impurity.

b. Method. - The solution resulting from the separation process contained, in addition to plutonium, a rather large amount of the element lanthanum, which was used in the final steps of the

separation process as a carrier precipitate. It was necessary to treat this solution in such a way that the plutonium would precipitate in a rather pure state, leaving the lanthanum and other impurities in solution. Based on information gained by the processing of some 37 batches of material in a specially designed laboratory (See App. A 5h), a method, based on the precipitation, solution, and reprecipitation of plutonium peroxide from the solution received from the separation plant, was developed. Studies made, to determine the best plutonium compound for shipment of the product between sites, indicated that the nitrate was most satisfactory for general use. Recommendations for an isolation process were furnished the Hanford Engineer Works in two formal reports (See App. C 7, 9).

5-6. Uranium Wastes.

a. Storage. - In view of the limited world supply of uranium metal, provisions were made for storing the waste uranium solutions from the Separation Building in large underground storage tanks (See App. A 22, 3h). Six tanks, having a total capacity of about one million gallons, were provided, and these also served as storage tanks for radioactive waste solutions from the Separation Building, before ultimate discharge into nearby streams.

b. Recovery. - The development of a process for the recovery of uranium, held up in the active waste solutions from the separation process tests, was begun in the fall of 1944. A recovery process, based on the extraction of the uranium from a water solution by an organic solvent, was carried through the initial phases of process design and promised to be a very satisfactory method (See App. C 10, 11).

Inasmuch as the handling of this large bulk of solution would be simplified as time went on, because the radioactive fission products were disintegrating and thus becoming stable, and since there was no immediate demand for recovery of the uranium metal either at Clinton Laboratories or at the Hanford Engineer Works, the work on this problem was limited to the development of a process for uranium recovery to be used at some future date.

5-7. Completion of Work. - During the period from December 1943 to January 1945, a total of 299 batches of irradiated uranium slugs were processed in the Separation Building, using three different type charges, all of which yielded excellent results. Valuable information was gained in the operating techniques connected with the separation process, through the work done in the Clinton Laboratories pilot plant, and key personnel, who were later to be assigned to the Hanford Engineer Works, were given a thorough training course in the fundamentals of process operation. At the conclusion of the operating period, January 1945, experienced personnel carried out a thorough program to remove all radioactive substances from the equipment and cells, so that the pilot plant could be placed in a standby condition.

5-8. Development of Alternate Process. - Although the Bismuth Phosphate Process had been accepted for use at Hanford, a group of chemists at Clinton Laboratories was assigned the task of developing an alternate process for the separation of plutonium from the uranium and fission products by an adsorption method. This research was believed to be necessary, since this new method, if successful, would be very simple both as to construction and operation and would provide

an alternative in the event of the failure of the precipitation process. Sufficient results were accumulated, based upon the behavior of the adsorption systems studied, to show that, by the use of simple "adsorption columns,"\* a process for the separation of plutonium from the undesirable contaminants would be quite feasible. However, in June 1944, when it became obvious that the Bismuth Phosphate Process would be satisfactory for use at Hanford, research work on the alternate method was discontinued.

5-9. Chemical Studies of Fission Products and Heavy Elements. -

Chemical research connected with uranium, plutonium, other heavy elements, and the fission products was begun in September 1943, but was of secondary importance because of the urgency of process development problems and their manpower demands. However, with the discharge of responsibilities in this field, basic chemical research increased until it occupied a large part of the chemists' program at Clinton Laboratories. The fields for study have been the chemical clarification of the phenomena associated with fission, the chemical potentialities of the Clinton Pile, and the characteristics of the various nuclear reactions.

a. Studies of the Process of Fission. - Studies of the process of fission have led to a more accurate idea of the proportion of the total energy of fission which is contained in the radioactive fission products and of the rate of release of this energy. The products of fission, of which about 150 are now known, have been further characterized with respect to amounts produced, chemical properties, nature of radiation emitted, and rates of decay. Information of this

~~CONFIDENTIAL~~

type, collected in conjunction with the staff of the Metallurgical Laboratory, has been used in improving the plutonium separation process and in planning for personnel protection and waste uranium disposal at Hanford (See App. C 12).

b. Studies of the Chemistry of Plutonium. - Prior to Clinton start-up, plutonium existed only in microscopic amounts and its chemical and physical properties were not known as well as was desired. Therefore, a program for the study of the chemistry of plutonium was inaugurated as soon as sufficient amounts were made available. The development of the separation process depended to a great extent upon the results of this research. A number of immediate problems attacked included the study of the suitability of various plutonium compounds for their ease of preparation, stability, ability to withstand storage and shipment, and degree and ease of solubility.

5-10. Radioisotopes. - Following the end of hostilities, much of the work of the scientific and technical groups was directed toward developing peace time uses of the various piles. Radioisotopes developed therefrom were to be used in the fundamental and applied sciences, particularly biological and medical. The release for public use of these isotopes was one of the most significant peace time results of the great investment in nuclear fission. On 3 January 1946, the first complete, specific proposal for the national distribution of pile-produced radioisotopes was presented by memorandum from Clinton Laboratories to the Director of the Medical Division, Manhattan District. Formal inauguration of the distribution program was made by the announcement from Headquarters, Manhattan Project, entitled "Availability of



[REDACTED]

Radioactive Isotopes," which appeared 14 June 1946, in "Science," Vol. 103, Pages 697-705, listing available isotopes (approximately 100 in number) and also covering principles of distribution and details of procurement. It was determined that distribution should be limited to elements number 3 to 83, inclusive.

a. Laboratory Expansion. - Expansion of Hot Laboratory

#706-C was underway by this time in order to keep separation facilities abreast of increased pile activity. On 2 August 1946, the Barnard Free Skin and Cancer Hospital, St. Louis, Missouri, received the first peacetime product of the huge Atomic Energy Facilities. At appropriate formalities in front of the Clinton Pile, the Deputy District Engineer delivered a one-millicurie unit of Carbon 14 to Dr. E. V. Cowdry, of the St. Louis Institution, who desired the carbon to "tag" component parts of cancer-producing molecules and then, through radiation measuring instruments, to seek an answer to this question: "Why does this particular molecule produce cancer?" Since that date and to 31 December 1946, 306 requests for radioisotopes were received, representing 45 different elements. Of the total orders received, shipments at the year's end totaled 125 with a sales value of \$29,800.00.

[REDACTED]

## SECTION 6 - DESIGN AND OPERATING PROBLEMS

6-1. General. - As the design and construction of the large-scale plutonium-producing plants proceeded, it was essential that the research and development program should concern itself with problems associated with successful and uninterrupted operation. The most difficult of these problems was the proper canning and testing of the uranium slugs. Before a slug was considered sound enough for use in a Pile, it was subjected to severe tests to determine its ability to withstand the intense radiation and the corrosion brought about by the passage of the coolant under radiation conditions. Another problem anticipated in early Pile operation was the poisoning effect of fission products of large neutron-capture cross section. Although as many as possible of these elements were identified and investigated early in the operation of the Clinton Pile, it was not until the start-up of the full-scale Piles that further complications appeared. Among the investigations made at Clinton Laboratories during the design of the large-scale production units were a test of the effectiveness of the shielding proposed for the Hanford Piles and a test of effect of radiation on materials used in Pile construction. The results obtained from experimentation and calculation at Clinton were transmitted directly to the du Pont Company by a small group of special technical liaison men and, thus, were made available for use at Hanford long before usual publication and distribution methods would have allowed.

6-2. Detection of Slug Swelling and Can Failure (See App. C 13-17).-  
Considerable attention was given to health and other hazards which

~~SECRET~~

might arise in case the aluminum jackets around the uranium slugs should be ruptured by chemical corrosion or by the effects of the heat produced in the Clinton and Hanford Piles. The first slugs used in the Clinton Pile were jacketed with a very light aluminum can sealed with an ordinary stitch-weld at the seams. During operation these slugs were expected to attain a temperature of about 218° Centigrade. In view of this, it was decided to test these slugs at this temperature. (Actually, the pile operating temperature was 250° Centigrade). Many of these light jackets failed when they were subjected to the heat test given to them prior to insertion into the Pile. A method of canning was developed later by the Metallurgical Laboratory and the du Pont Company which proved to be quite adequate (See Vol. 2, Part I; Vol. 3; Vol. 6). Essentially, this method provided for arc-welding the seams of the aluminum cans under an atmosphere of argon gas.

a. Tests Developed to Detect Jacket Failure. - Testing of the slug jackets prior to insertion in the Clinton Pile was accomplished by a variety of methods. Initially, the testing of the aluminum-canned uranium slugs was performed by heating the slugs to 300 degrees Centigrade for ten hours at a hydrogen pressure of two atmospheres. This procedure was continued until it was found that some of the slugs passing the test contained hydride. Thereafter, slugs were tested by the deflection test, in which the welded end of the can was exposed to a nitrogen pressure of 200 pounds per square inch and the deflection in mils of the opposite end of the can was observed. This test rejected about 45 per cent of the slugs received

[REDACTED]

at the site. In order to determine the percentage of defective slugs among those already accepted for charging, a group of 5000 was given a second deflection test. Two per cent showed deflections greater than six mils. That is, a group of 20 slugs showing this deflection represented the worse elements of 1000 slugs. It also appeared desirable to test the metal under the most unfavorable circumstances to determine safe operating conditions. A performance test was made using 1000 slugs held at an air temperature of 200 degrees Centigrade for two months. Of this number a few failures, in which the cans swelled or broke, were observed. After the development of an improved jacket, another test was developed in which the slugs were heated to a high temperature (about 500 degrees Centigrade) and held there for about ten days. From weights of the slugs before and after this heat treatment, faulty cans could be detected because the uranium metal upon exposure to air at this temperature became oxidized and thus gained weight (See App. A 55).

b. Routine Testing. - The testing of the entire quantity of slugs which were contained in the improved argon arc-welded jackets was completed in February 1945. Of approximately 104,000 slugs tested, less than four per cent were rejected for all reasons. It is of importance to note that little difficulty has ever been experienced to date with ruptured slugs in either the Clinton or Hanford Piles.

c. Corrosion of Uranium Slugs. - Since water was to be used as the coolant for the Hanford production Piles, the susceptibility of the aluminum cans to corrosion under Pile conditions was investigated. Water of composition similar to that in the Columbia

SECRET

River was passed through a special experimental channel constructed to simulate a Hanford tube, and the corrosion of the jackets of the aluminum-silicon bonded slugs (See Vol. 3) was noted. When the discharged slugs were examined, one which was several feet from the center of activity during the test was found with the cap completely removed. It appeared that water had passed through a hole back of the weld, and that the oxide formed on the end of the heavy metal had exerted sufficient force to push the cap off. The slug was swollen at the end and the bonding material was cracked in several places. No other slugs were in such a state, although large pits and swollen areas were detected near the welded seams on several slugs. With improvement in the aluminum-silicon bonded slugs brought about by improved techniques in canning and welding, the corrosion rates indicated that corrosion under radiation would not be appreciably greater than that observed where there is no radiation, indicating that no difficulty with slug failures was expected to be encountered.

6-3. Pile Poisoning (See Vol. 2, Part I; Vol. 6). - Simultaneously with the production of plutonium in an operating Pile, an approximately equal weight of the many fission products of uranium is formed. These fission products are ordinary elements which may or may not be radioactive, depending, in general, upon certain statistical laws. Often, however, one or more of these fission products are of such a nature as to be incompatible with the normal operation of the Pile. That is, the mere existence of these materials in the Pile may prevent its operation by virtue of their ability to absorb neutrons readily, thereby decreasing the number of neutrons available to carry

[REDACTED]

on the fission chain. It was realized that an accumulation of these fission products might create a condition such as to make it impossible for the Clinton or Hanford Piles to operate. Little was known about these poisoning effects at the time the Clinton Pile was put into operation. However, two rare elements, samarium and gadolinium, were known to be produced as a result of uranium fission and to have a very high poisoning effect, but certain essential facts that would determine how troublesome these might be to Hanford operations were not known. In view of this, Clinton Laboratories, in cooperation with a similar group of physicists at the Metallurgical Laboratory, undertook a study of the problem by exposing samples of these rare earth elements in the operating unit and examining the resulting products for their inhibiting effect on the Pile. From this work it was concluded that these particular two elements would not give rise to any serious difficulties in connection with the Hanford operations (See App. C 18). However, shortly after the Hanford start-up, a radioactive isotope of the rare gaseous element xenon formed in the fission process was discovered to be about a thousand times more detrimental as a poisoning agent than anything previously encountered. Indeed, it appeared at first that the production of this gas might make it impossible to operate the Hanford production Piles. The problem was given very intensive study by the physicists and chemists at Hanford, Clinton Laboratories, and the Metallurgical Laboratory with the result that a method of operation was worked out which eliminated the difficulty in a satisfactory manner (See Vol. 6).

6-4. Testing of Proposed Shield (See App. C 19, 20). - After the

SECRET

development of the special type of masonite, which had been found to be an excellent shielding material, it was necessary that the laminated steel-masonite shield to be used in the production Piles be tested. Two such tests were performed at Clinton Laboratories. In the first case, an imperforate section of the shield, with an effective lower surface of 25 square feet, was inserted in a special opening provided in the Clinton concrete shield. Since the radiation level at the graphite, due to gamma radiation from fission products, after a shut-down, would be such as to render the area untenable after any appreciable amount of production operation, it was necessary that this test be performed during the start-up program and that the accumulated energy during this period be limited to about 500 kilowatt-hours. The second test involved the testing of a shield section containing the proper formula of iron and masonite for both the "thermal shield" and the biological shield. This sample, four feet square, was perforated by a single metal charging tube. This assembly was a perfect facsimile of the geometry to be used in the Hanford Piles, although the tube contained four longitudinal ribs instead of the two used in the final design (See Vol. 3). However, the difference between these two tube sizes was considered to be immaterial as far as the test was concerned. The section of shield was placed outside the Pile shield directly behind a steel tank ordinarily filled with water. This tank extends through the concrete shield so that, when empty, radiation from slugs could impinge upon the shield section after having passed through only two inches of steel. Measurements, in both cases, made by use of foils, ionization chambers, photographic plates, and other devices, indicated

[REDACTED]

that the proposed shield would be adequate and would reduce the intensity of all dangerous radiation to well below the tolerance level.

6-5. Testing of Materials for Use in Hanford Piles (See App. C 21, 22). - The effects of the intense radiation, expected to be encountered in the Hanford Piles, on ordinary materials of construction and materials which might be placed within the Piles, such as coolants, were unknown. Many materials were exposed in the Clinton Pile in an effort to determine whether or not there were any significant changes in their physical properties as a result of irradiation. A synthetic water of the composition found in the Columbia River was circulated throughout a test tube in the Clinton Pile under various Pile levels. Calculations predicted that the hydrogen peroxide concentration in the exit water of the Hanford Piles would be negligible; that the removal of oxygen (de-aeration) would decrease the initial rate of formation of hydrogen peroxide by 50 per cent; and that saturation with oxygen would increase this rate by 30 per cent. Included among construction materials tested in the Pile were aluminum, steel, graphite, masonite, brass, "neoprene," bakelite, and concrete. These materials were irradiated for <sup>periods of</sup> ~~times~~ of the order of several weeks, corresponding to approximately 200 megawatt-hours. The decay of the beta and gamma activities induced in these substances was followed on "Geiger counters." Several of these materials were found to possess very low activities. Among the more interesting of the obvious physical changes occurring were: (a) bakelite showed no obvious harmful effects after several weeks of irradiation at 500 kilowatts; (b) rubber tubing lost its elasticity and broke into pieces under light



~~SECRET~~

pressure; and (c) neoprene retained its strength and elasticity after three weeks of irradiation at 300 kilowatts.

~~SECRET~~

~~SECRET~~

## SECTION 7 - TRAINING OF PERSONNEL

7-1. General. - The unique nature of the various processes having to do with the production, separation, and isolation of plutonium, and the fact that very few people had received training in this entirely new field, made it necessary to provide adequate facilities for the training of additional personnel. Consequently, Clinton Laboratories, both under the University of Chicago and later Monsanto Chemical Company operation, organized and operated training schools for its own personnel; in addition, the University school trained two groups of du Pont employees, who were eventually transferred to Hanford Engineer Works as a nucleus for its operating personnel, while the Monsanto school was established to train a nucleus of technical personnel in fields of Nuclear Science.

7-2. Facilities. - Both school programs utilized the principle of regular classroom work, but the earlier program required all trainees to supplement basic principle classroom training with part-time work in the actual operation of pilot plant facilities. To provide the most proficient training program possible in the shortest period of time, a small mock-up unit, having the same fundamental characteristics as the large ones being built at Hanford Engineer Works, was made available and successfully used in connection with the Chicago training program. This mock-up unit had, insofar as was practical, the same type of equipment as was expected to be used at Hanford.

7-3. Personnel Trained.

a. University of Chicago Program. - One group of 183

trainees, new employees of the du Pont Company, received training in the particular part of the work in which they would be engaged at the Hanford Engineer Works. The training was completed and the transfer of these new employees effected well in advance of Hanford start-up. A second group, 183 senior du Pont employees, also received training at Clinton Laboratories in this new type of work for several months. These employees were trained primarily in the supervision of certain phases of the process in order to gain experience before eventual transfer to the Hanford Engineer Works. In addition to the du Pont employees, a group of 29 Clinton Laboratories employees were trained in specialized phases of the work and transferred to Hanford prior to its start-up. Most of the members of this group received special training in the design and construction of special measuring instruments and their application to monitoring in connection with health hazards.

b. Monsanto Chemical Company Program. - In this phase of the program, a school for training a nucleus of technical personnel in fields of Nuclear Science was established in August 1946, to run for a period ending in June 1947. <sup>(see APP. A-56)</sup> Upon the termination of this period of training at Clinton Laboratories, the trainees were to return to their parent organizations. The original concept of this seminar was that it would be at post-doctorate level and limited to 25 or 30 people; however, the school in practice included the following guest groups along with 37 assigned, scientifically noted, trainees:

- (1) 205 employees of, Clinton Laboratories.
- (2) 21 Government employees (including Navy and Air

[REDACTED]

Force Officers).

- (3) 7 Tennessee Eastman employees.
- (4) 4 Carbide and Carbon employees.
- (5) 3 NEPA employees.

For the direction of this activity, Clinton Laboratories obtained the part time services of Dr. Frederick Seitz.

7-4. Disposal of Equipment. - Following completion of the training program, the equipment installed in the mock-up unit was removed from the building for use at other locations and the building was turned over to Clinton Laboratories for use as a general shop.

[REDACTED]

## SECTION 8 - ORGANIZATION AND PERSONNEL

8-1. Design and Construction (See App. B 5). - The design and construction of the Clinton Laboratories were performed by the du Pont Company. E. G. Ackart was the Chief Engineer, in charge of the Design and Construction Divisions. The Assistant Chief Engineer was G. M. Read. M. F. Wood was the General Manager of the Construction Division while the Manager for War Construction (TNX) was F. H. Mackie. The District Superintendent for Clinton Laboratories was W. Irwin and J. D. Wilson was the Field Project Manager. For the Design Division, T. C. Gary was Manager, reporting to the Assistant Chief Engineer of the Design and Construction Divisions. J. P. Martel was the Assistant Manager of this division, while the Supervising Engineer for Clinton and Hanford Design was F. W. Pardee, Jr. The Design Project Manager for the TNX Section was H. T. Daniels.

8-2. Operation. - The operation of the Clinton Laboratories was the responsibility of the Metallurgical Laboratory (See Sec. 3). The first group of operating personnel moved from Chicago, Illinois, to Oak Ridge, Tennessee, in April 1943. This group consisted of eleven men, key scientific personnel who had been engaged in similar work at the Metallurgical Laboratory before their transfer to the Clinton Laboratories. The original group was augmented each month in accordance with the availability of living quarters and the completion of office space and laboratory facilities. By August 1943, a sufficient number of operating personnel had arrived on the plant site to serve as a framework for a well-rounded organization.

And B-8

a. Organization (See App. B 6).

(1) Under direction of the University of Chicago, the Clinton Laboratories was operated as a part of the Metallurgical Project with Dr. A. H. Compton as Director. As of February 1944, the Director of Clinton Laboratories was Dr. M. D. Whitaker, to whom the Associate Director of Research, the Director of the Health Division, and the Plant Manager reported. The Associate Director for Research was E. L. Dean. This group was further divided into three divisions, Chemistry, Separations Development, and Analytical, headed by W. C. Johnson, O. H. Greager, and D. M. Smith, respectively. The Director of the Health Division was S. T. Cantril, M. D., and S. W. Pratt was Plant Manager. Reporting to S. W. Pratt were the Production Superintendent, W. C. Kay; the Works Engineer, A. J. Schwertfeger; the Service Superintendent, E. A. Wentworth; and the Chief Accountant, E. C. Weber.

(2) Upon assumption of operating responsibility by the Monsanto Chemical Company, Dr. M. D. Whitaker remained as Director of the Laboratories until 1 June 1946, at which time he resigned to assume new duties as President of Lehigh University. To replace Dr. Whitaker, a co-directorship was adopted with Dr. J. H. Lum as the new Executive Director and Dr. E. P. Wigner as Director of Research. As Monsanto began operating the Laboratories, the du Pont Company recalled or terminated their Chicago University loaned employees as rapidly as possible.

b. Personnel (See App. B 7). - In August 1943, at the time of the formation of an operating organization, Clinton Laboratories

[REDACTED]

employed a total of 236 persons. The number of employees was gradually increased thereafter until June 1944. At that time the maximum number of employees, 1513, were engaged in plant operation, including those undergoing training for the operation of the Hanford Engineer Works. The transfer of this trainee group was well underway by July 1944, at which time the total number of employees started decreasing until, by the latter part of 1944, a more or less stabilized organization of approximately 1300 persons was reached. Because of the urgency of the work and the scarcity of well-trained and qualified technical civilian personnel, arrangements were made to have technically trained men of the Special Engineer Detachment transferred to Clinton Laboratories for duty. The first group consisted of ten men who reported during the month of January 1944. As qualified men became available, additional enlisted men were assigned to Clinton Laboratories, until the number finally reached a maximum of 113. Several of this group were given specialized training in certain phases of the work and were then transferred to other locations on the Project where the necessary training facilities were not available.

8-3. Corps of Engineers. - Since Clinton Laboratories was located only a few miles from the District Engineer's Office, where all Corps of Engineers administrative and service facilities such as the Selective Service Section, Priorities Section, and Contract Section were located, it was not necessary to maintain a large staff at the plant site. The organization at Clinton Laboratories consisted of three officers, Major E. J. Murphy, Operations Officer, Captain J. F. Grafton and Captain F. A. Valente, Assistants; two civilian



employees; three stenographers; and five enlisted men of the Special Engineer Detachment who rendered technical assistance. Four more enlisted men were added in June 1945, when it was found necessary to assume the responsibility of the transfer of certain classified special radioactive materials from Oak Ridge to other sites by truck convoy.



[See comments on  
back of A2]

**APPENDIX A**  
**MAPS, DRAWINGS, PHOTOGRAPHS, AND DESCRIPTIONS**

**MANHATTAN DISTRICT HISTORY**

**BOOK IV - PILE PROJECT**

**VOLUME 2 - RESEARCH**

**PART II - CLINTON LABORATORIES**

**APPENDIX A**

**MAPS, DRAWINGS, PHOTOGRAPHS, AND DESCRIPTIONS**

<u>No.</u>	<u>Description</u>
1	Map - Index and Road Map - Clinton Engineer Works
2	Map - Layout of Clinton Laboratories
3	Diagram - Details of Graphite Matrix Assembly
4	Diagram - Vertical Section through Pile
5	Diagram - Openings in Metal Charging Face
6	Diagram - Elevation of Right and Left Side Walls
7	Diagram - Elevation of Discharge End Wall
8	Diagram - Plan View of Pile Top
9	Diagram - Typical Closure of Charging End of Metal Tube
10	Diagram - General Arrangement - Air Cooling System
11	Diagram - Section through Shim and Regulating Rod Assembly
12	Diagram - Plan of Shim and Regulating Rod Assembly
13	Diagram - Elevation of Shim and Regulating Rod Assembly
14	Diagram - Gravity Safety Rods
15	Diagram - Control Panel
16	Diagram - Separation Plant - General Arrangement
17	Diagram - Control Panel - Coils 2, 3, 4
18	Diagram - Equipment of Cell No. 2 - Lower Vessels
19	Diagram - Equipment of Cell No. 2 - Upper Vessels
20	Diagram - Drainage and Waste System for Building 205
21	Diagram - Waste Disposal System
22	Diagram - Main Metal and Liquid Wastes Storage - Typical Section
23	Photo - Aerial View of Clinton Laboratories
24	Photo - Pile Building under Construction (6/4/45)
25	Photo - Pile Building under Construction (6/27/45)
26	Photo - Pile Building under Construction (7/14/45)
27	Photo - Aerial View of Pile, Separation, and Exhauster Buildings during Construction (8/31/45)
28	Photo - Completed Pile Building - Looking North (10/11/45)
29	Photo - Completed Pile Building - Looking Southeast (10/11/45)
30	Photo - Completed Exhauster Building - Looking East (10/11/45)
31	Photo - Exhauster Building and Exhaust Stack - Looking Northeast (11/11/45)
32	Photo - East End of Clinton Laboratories Area (12/20/45)
33	Photo - Completed Pile Building and Separation Building (12/20/45)

~~SECRET~~

<u>No.</u>	<u>Description</u>
34	Photo - Waste Storage (206) Area under Construction (7/14/43)
35	Photo - Completed Waste Storage (206) Area
36	Photo - White Oak Creek Dam and Sluice Gate (6/27/43)
37	Photo - Completed Water Treatment (807) Building
38	Photo - Completed Pump House (814) Building (8/10/43)
39	Photo - Steam Plant under Construction (7/14/43)
40	Photo - Steam Plant and Reservoir under Construction (10/6/43)
41	Photo - Completed Steam Plant - Locking Northwest (3/13/44)
42	Photo - Chemistry Laboratory (706 A) Building - Locking Southeast (3/13/44)
43	Photo - "Hot" Laboratory (706 C) Building - Locking Northeast (3/13/44)
44	Photo - Propane Storage Tanks
45	Photo - Ordinary Chemicals Storage Platform
46	Photo - Air Cooling System Fan
47	Photo - Pile Control Panel
48	Photo - Charging Face of Clinton Laboratories Pile
49	Photo - Charging Face of Clinton Laboratories Pile
50	Photo - Apparatus for Constant Surveillance of Cooling System
51	Photo - Control Panels in Semi-Works Separation Plant
52	Photo - Remote Control Panels in Separation (205) Building
53	Photo - Typical Counting Room at Clinton Laboratories
54	Photo - Section of Isolation Laboratory
55	Photo - Electric Ovens for Jacket Testing
56	Photo - Bldg. No. 735-B - Training Building
57	Photo - Bldg. No. 706-C - Chemistry Separations Laboratory

~~SECRET~~

ACCESS RD. R/W EXTENDS TO SOUTHERN R.R. (BLAIR)

FILE NO. CG

FILE NO. CK-0111-1.2

ACCESS RD. R/W EXTENDS TO U.S. HWY. NO. 70

Clinton Laboratories

FILE NO. CX-0111-1

Roane County  
Loudon County

Loudon County  
Knox County

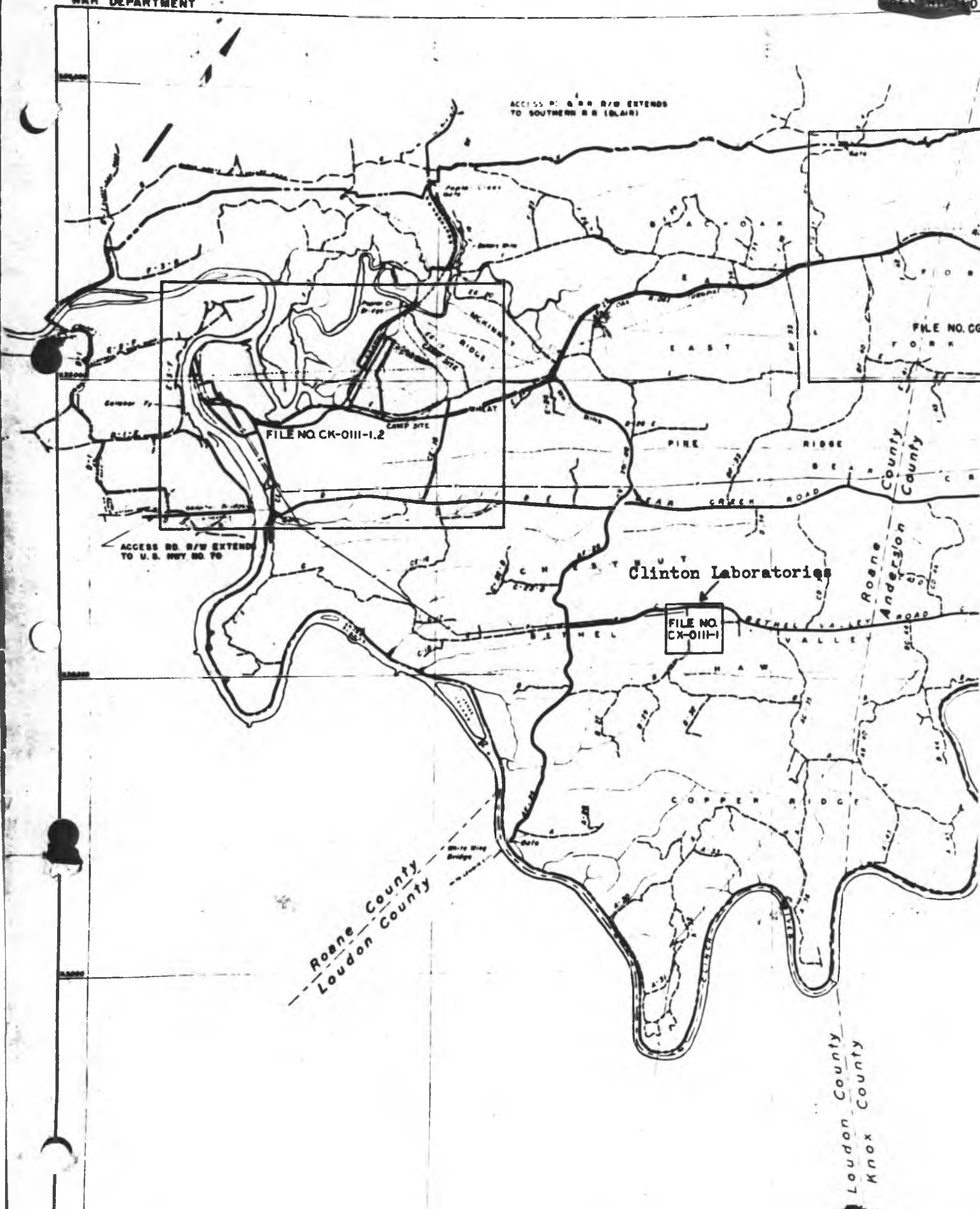

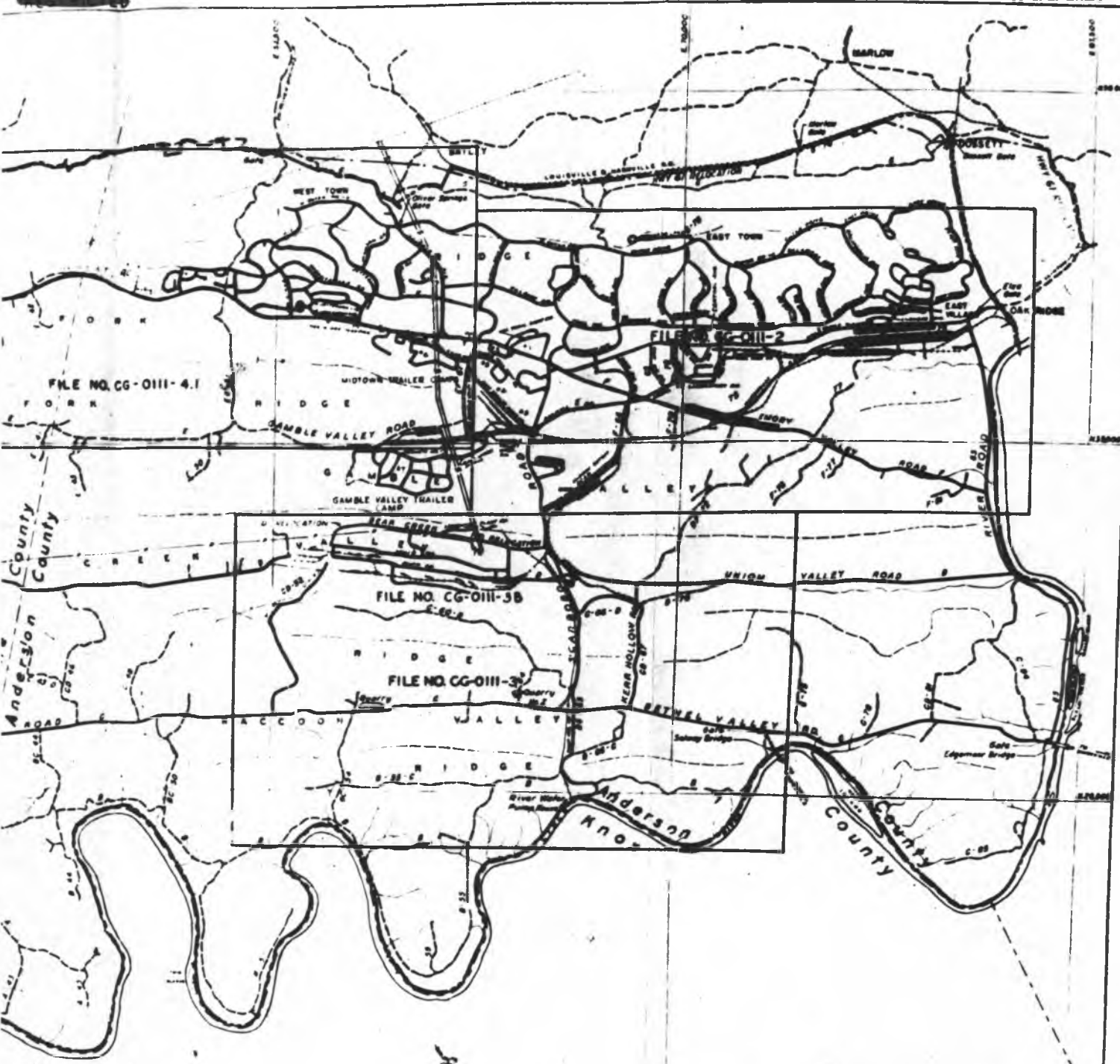

**LEGEND**

NEW AND IMPROVED ROADS COMPLETED

NEW ROADS UNDER CONSTRUCTION

EXISTING SECONDARY ROADS

RAILROADS COMPLETED

RAILROADS UNDER CONSTRUCTION

PROPERTY LINE

NO.	DATE	REVISION	BY	CHKD.	APP'D.
1	7-27-44	INITIAL DESIGN DRAUGHT UP TO DATE AS OF FEB 25, 1944	...	...	...
2	8-1-44	...	...	...	...
3	8-1-44	...	...	...	...
4	8-1-44	...	...	...	...
5	8-1-44	...	...	...	...
6	8-1-44	...	...	...	...
7	8-1-44	...	...	...	...
8	8-1-44	...	...	...	...
9	8-1-44	...	...	...	...
10	8-1-44	...	...	...	...
11	8-1-44	...	...	...	...
12	8-1-44	...	...	...	...
13	8-1-44	...	...	...	...
14	8-1-44	...	...	...	...
15	8-1-44	...	...	...	...
16	8-1-44	...	...	...	...
17	8-1-44	...	...	...	...
18	8-1-44	...	...	...	...
19	8-1-44	...	...	...	...
20	8-1-44	...	...	...	...
21	8-1-44	...	...	...	...
22	8-1-44	...	...	...	...
23	8-1-44	...	...	...	...
24	8-1-44	...	...	...	...
25	8-1-44	...	...	...	...
26	8-1-44	...	...	...	...
27	8-1-44	...	...	...	...
28	8-1-44	...	...	...	...
29	8-1-44	...	...	...	...
30	8-1-44	...	...	...	...
31	8-1-44	...	...	...	...
32	8-1-44	...	...	...	...
33	8-1-44	...	...	...	...
34	8-1-44	...	...	...	...
35	8-1-44	...	...	...	...
36	8-1-44	...	...	...	...
37	8-1-44	...	...	...	...
38	8-1-44	...	...	...	...
39	8-1-44	...	...	...	...
40	8-1-44	...	...	...	...
41	8-1-44	...	...	...	...
42	8-1-44	...	...	...	...
43	8-1-44	...	...	...	...
44	8-1-44	...	...	...	...
45	8-1-44	...	...	...	...
46	8-1-44	...	...	...	...
47	8-1-44	...	...	...	...
48	8-1-44	...	...	...	...
49	8-1-44	...	...	...	...
50	8-1-44	...	...	...	...

**INDEX AND ROAD MAP  
STATUS OF CONSTRUCTION**

IN 4 SHEETS      SHEET NO 1      SCALE 1"=2400'

U.S. ENGR OFFICE - MANHATTAN DIST., KNOXVILLE, TENN. JULY 31, 1943

APPROVED: *[Signature]*  
ENGINEER

FILE NO. CG-OIII-1-  
DATE: \_\_\_\_\_

This document contains information affecting the national defense of the United States within the meaning of the Espionage Laws, Title 18, U.S.C. Sec. 793 and 794, as amended, the transmission or the revelation of its contents in any manner to an unauthorized person is prohibited by law.

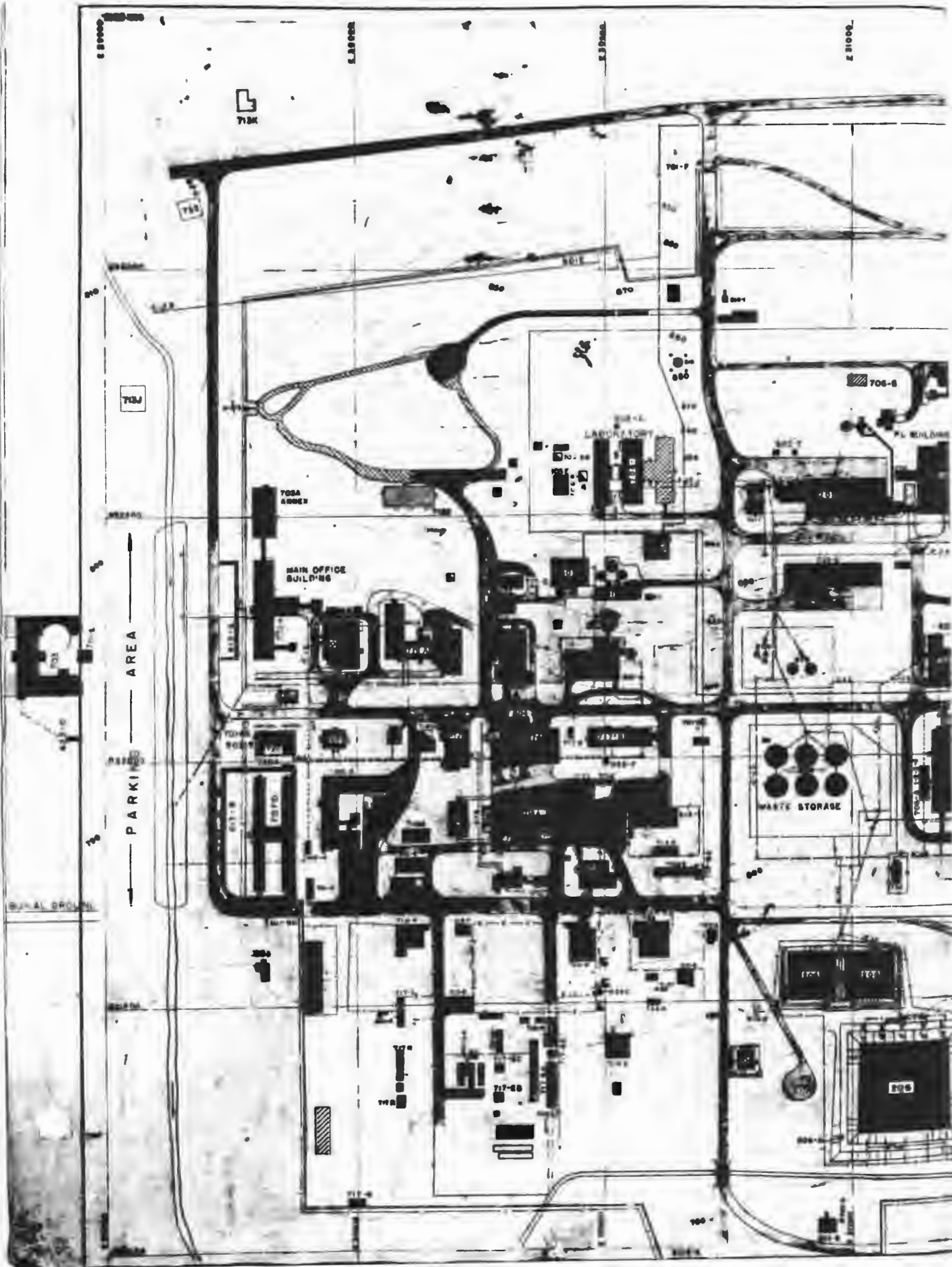

**SECRET**

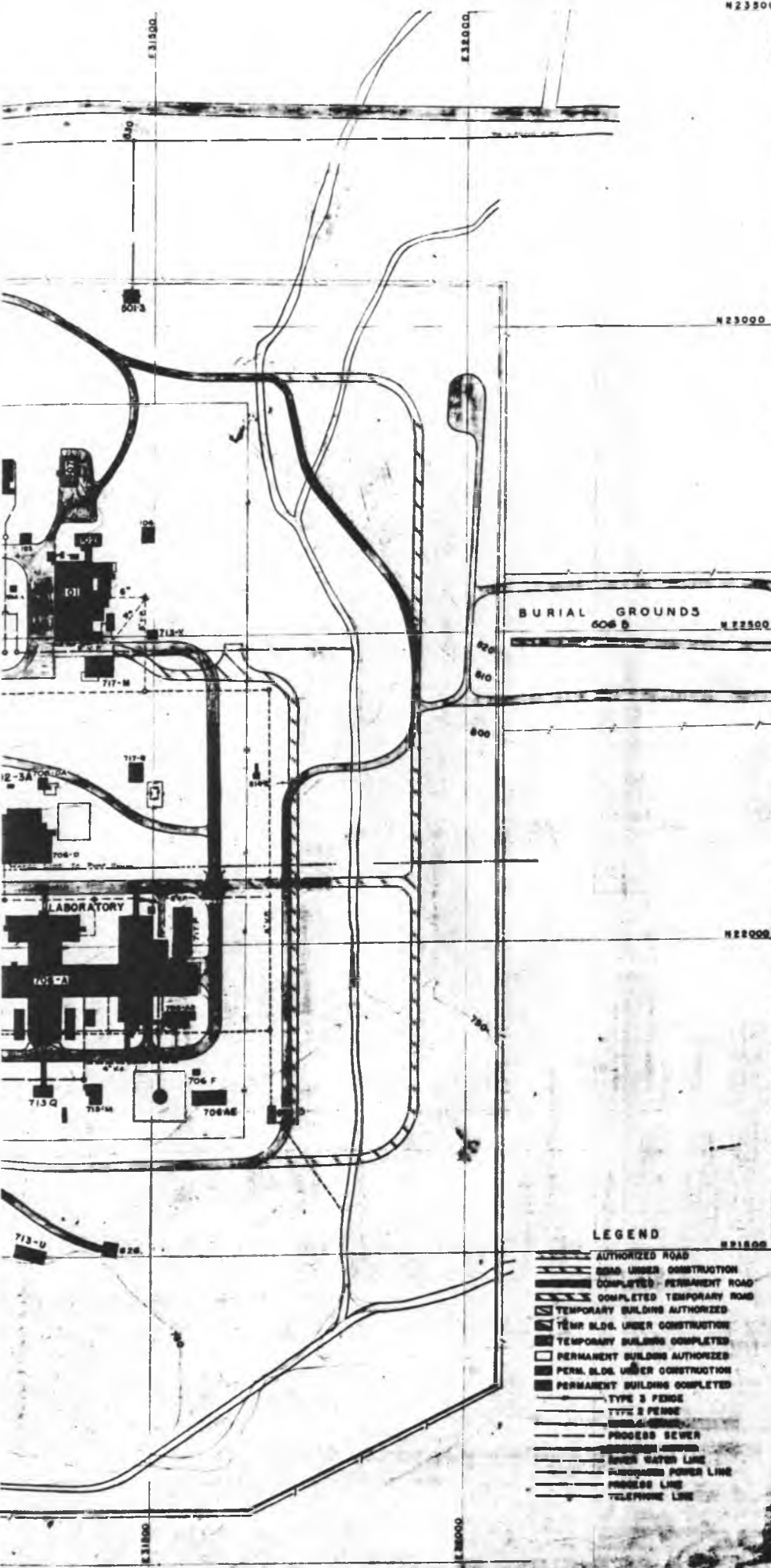

BURIAL GROUNDS  
 606 B

**LEGEND**

- AUTHORIZED ROAD
- ROAD UNDER CONSTRUCTION
- COMPLETED PERMANENT ROAD
- COMPLETED TEMPORARY ROAD
- TEMPORARY BUILDING AUTHORIZED
- TEMP BLDG UNDER CONSTRUCTION
- TEMPORARY BUILDING COMPLETED
- PERMANENT BUILDING AUTHORIZED
- PERM. BLDG UNDER CONSTRUCTION
- PERMANENT BUILDING COMPLETED
- TYPE 3 FENCE
- TYPE 2 FENCE
- SLOTTED DRAIN
- PROPOSED SEWER
- PROPOSED WATER LINE
- PROPOSED POWER LINE
- PROPOSED LINE
- TELEPHONE LINE

SECTION	CONST. PROGRAM REQUEST UP TO DATE AS OF	DES.			
SECTION 1-21-48	CONST. PROGRAM REQUEST UP TO DATE AS OF MAR. 31, 1948	S.L.T.			
SECTION 2-21-48	CONST. PROGRAM REQUEST UP TO DATE AS OF DEC. 31, 1948	M.S.H.			
SECTION 3-21-48	CONST. PROGRAM REQUEST UP TO DATE AS OF JUNE 30, 1948	S.L.T.			
SECTION 4-21-48	CONST. PROGRAM REQUEST UP TO DATE AS OF MAR. 31, 1948	S.L.T.			
SECTION 5-21-48	CONST. PROGRAM REQUEST UP TO DATE AS OF DEC. 31, 1948	S.L.T.			
SECTION 6-20-48	CONST. PROGRAM REQUEST UP TO DATE AS OF SEPT. 30, 1948	S.L.T.			
SECTION 7-20-48	CONST. PROGRAM REQUEST UP TO DATE AS OF JUNE 30, 1948	S.L.T.			
SECTION 8-20-48	CONST. PROGRAM REQUEST UP TO DATE AS OF MAR. 31, 1948	S.L.T.			
SECTION 9-23-48	CONST. PROGRAM REQUEST UP TO DATE AS OF FEB. 28, 1948	E.S.			
SECTION 10-21-48	CONST. PROGRAM REQUEST UP TO DATE AS OF APR. 30, 1948	E.S.			
SECTION 11-21-48	CONST. PROGRAM REQUEST UP TO DATE AS OF DEC. 31, 1948	E.S.			
SECTION 12-21-48	CONST. PROGRAM REQUEST UP TO DATE AS OF SEP. 30, 1948	E.S.			
SECTION 13-21-48	CONST. PROGRAM REQUEST UP TO DATE AS OF APR. 30, 1948	E.S.			
SECTION 14-21-48	CONST. PROGRAM REQUEST UP TO DATE AS OF JULY 31, 1948	S.L.T.			
TYPE	DATE	REVISION	REV BY	CHK BY	AP BY

DESIGNED AND CONSTRUCTED BY E. I. DU PONT DE NEMOURS COMPANY  
 OPERATED BY CLINTON LABORATORIES

**SECRET**  
 LOCATION PLAN AND STATUS OF CONSTRUCTION **App. A2**

NO. 1 SHEET SHEET NO. 1 SCALE: 1" = 150'

MR. ENGR. OFFICE - ...

~~SECRET~~

TRX AREA

BUILDING LIST  
December 31, 1946

100 AREA

101 100 Area Field Office, Shops, Research Offices  
and Laboratory

102 Research Offices

103 Vault

104 Health Physics Test Building

105 Pile Building

105-B Experimental Test Building

115 Pan House and Biological Laboratory

200 AREA

204 Stack Laboratory

205 Separations Building

206 Waste Disposal

206-A Settling Basin Shed

500 AREA

501-A Elec. Substation at Power House Area

501-B Elec. Substation at River Pump House

501-C Elec. Substation for 105 Building

501-D Elec. Substation for 115 Building

501-E Elec. Voltage Regulation Station

502 #1 706-A Emergency Generator S. W.

~~SECRET~~



500 AREA (Continued)

- 502 #2 706-A Emergency Generator H. E.
- 502 #3 706-B Emergency Generator
- 502 #3A 706-B Emergency Generator
- 502 #4 105 Emergency Generator
- 502 #5 205 Emergency Generator
- 502 #6 706-B Emergency Generator
- 502 #7 717-B Emergency Generator
- 502 #8- 719-A Emergency Generator
- 502 #9 720 Emergency Generator
- 502 #10 Salvage Yard Emergency Generator (Portable)

600 AREA

- 603 Buildings, Roads and Walkways - Topography
- 604 Truck Scales
- 605 Fences
- 606-A Burial Ground (Orig.)
- 606-B Burial Ground - East
- 606-C Burial Ground - West
- 612 Open Drainage Ditches
- 613-A Parking Lot
- 613-B Parking Lot
- 613-C Parking Lot West of Creek
- 614-1 E. Guard Tower
- 614-2 E. Guard Tower

**SECRET**

THE AREA  
December 31, 1947

Page 3

600 AREA (Continued)

614-3 S. Guard Tower  
614-4 S. W. Guard Tower  
614-5 N. W. Guard Tower  
615 Fence Lighting  
622 Overhead Steam Lines  
623 Underground Water Lines (Filtered Water - Includes  
Rain Water not used for Fire Protection)  
624 Air Lines  
625 Sewers  
625-A W. Septic Tank  
625-B E. Septic Tank  
625-C S. Septic Tank  

---

625-D Septic Tank for Building 703-G  
626 Incinerator  
626-4,4B Incinerators  
630 Fire Protection (Rain Water) (Fire Lines and Tank)  
631 Outside Overhead Line Supports  
632 White Oak Creek Dam  
633 Hatch Plant

700 AREA

701-A W. Clock Alley  
701-1A W. Gate House  
701-B Operation Gate House

**SECRET**

~~SECRET~~

TRK AREA  
December 31, 1947

Page 4

700 AREA (Continued)

701-C Colored Clock Alley  
701-CC S. W. Gate House  
701-D S. Gate House  
701-E Guard Gate for Building 703-G  
701-F Guard Gate for N. Entrance  
701-G Guard Station Cells 6 and 7, 205 Bldg. (Inside bldg.)  
702- Telephones System  
703-A Administration Building and Annex  
703-B Engineering Building  
703-G Office Building and Annex  
704-A 200 Area Office  
706-A Chemistry Laboratory  
706-A1 Hutments Office Space W. of 706-A  
706-A2 Hutments Office Space W. of 706-A  
706-A3 Hutments Office Space W. of 706-A  
706-A4 Hutments Office Space W. of 706-A  
706-AB Oxygen and Acetylene Storage  
706-AC Equipment Storage  
706-AD Storage Garden  
706-AE Solvent Storage  
706-B Physics Laboratory  
706-BA Hutments - Temporary Offices  
706-BB Laboratory Annex

~~SECRET~~

700 AREA (Continued)

706-C Chemistry Separations Laboratory  
706-D By-Product Processing  
706-DA Fan House  
706-F Analytical Laboratory Storage - 706-A  
706-G Radium-Beryllium Source Bldg.  
707-A White Change House (Service Area)  
707-B Colored Change House (Service Area)  
707-C White Change House (Operating Area)  
707-D White Change House  
708 Cafeteria

---

710-A Former Paymaster's Booth (Empty)  
710-B Paymaster's Booth  
713-A Central Stores  
713-B Miscellaneous Storage  
713-C Building Supply Storage  
713-D Lumber Storage  
713-E Receiving Warehouse  
713-F Pipe Storage  
713-G Automotive Storage  
713-GA Automotive Storage (Invent)  
713-H Empty  
713-I Miscellaneous Storage (Stables)  
713-J Miscellaneous Storage (Construction Fire Hall)

700 AREA (Continued)

713-L Miscellaneous Storage (Bethel Church)  
713-M Acid Storage at 706-A  
713-O Cylinder Storage Platform  
713-P Storage Warehouse  
713-Q Solvent Storage  
713-R Spare Parts Storage  
713-S Oil Drum Storage  
713-U Carboy Storage  
713-V Outside Oil Storage - Near Garage  
713-X Health-Physics Hutment Storage  
713-Y Rolling Mill Storage. Hutment East of Bldg. 101  
715 Flag Pole  
717-A Central Shops  
717-B Instrument Shops  
717-BA Instrument Storage (Hutment)  
717-C Carpenter Shop  
717-D Paint Shop  
717-E Salvage Shop  
717-EA Storage Facilities  
717-EB Storage Facilities  
716-EC Storage Facilities  
717-ED Storage Facilities  
717-EE Salvaged Pipe Storage

700 AREA (Continued)

717-F Labor Office  
717-G Transportation Field Office  
717-H Insulation Storage  
717-I Lead Burning Shop  
717-J Millwright and Electrical Shops  
717-K Sheetmetal Materials Storage  
717-L Riggers' Shop  
717-M Elec. Shop (100 Area)  
717-N Labor Tool Storage  
717-O Lead Furnace Area  
717-P Area Shop 706-A  
717-Q Storage Building for 706-O

---

717-R Labor Equipment Storage  
717-S Storage Hutment S. W. Corner of Plant Area  
719-A Medical and Biological Laboratory  
719-B Urine Analysis Laboratory  
720 Patrol and Fire Headquarters  
720-A Fire Equipment Storage  
723 Laundry  
724-B E. Gasoline Station  
725 Garage  
725-A Grease Rack  
726 Propene Gas House and Lines

~~SECRET~~

700 AREA (Continued)

- 733 Construction Field Offices
- 735 Conference Building
- 735-B Training Building (Formerly 713-T)
- 745 Pistol Range
  
- 801-A Steam Plant
- Temporary Boiler House West End Project
- Reservoir
- Purchased Power
- 811 Power Area Office
- 812 Reservoir Pump House
- 813 Filter Plant
- 814 River Pump House
- 815 Overhead Water Tank



~~SECRET~~

628324  
12384  
38002

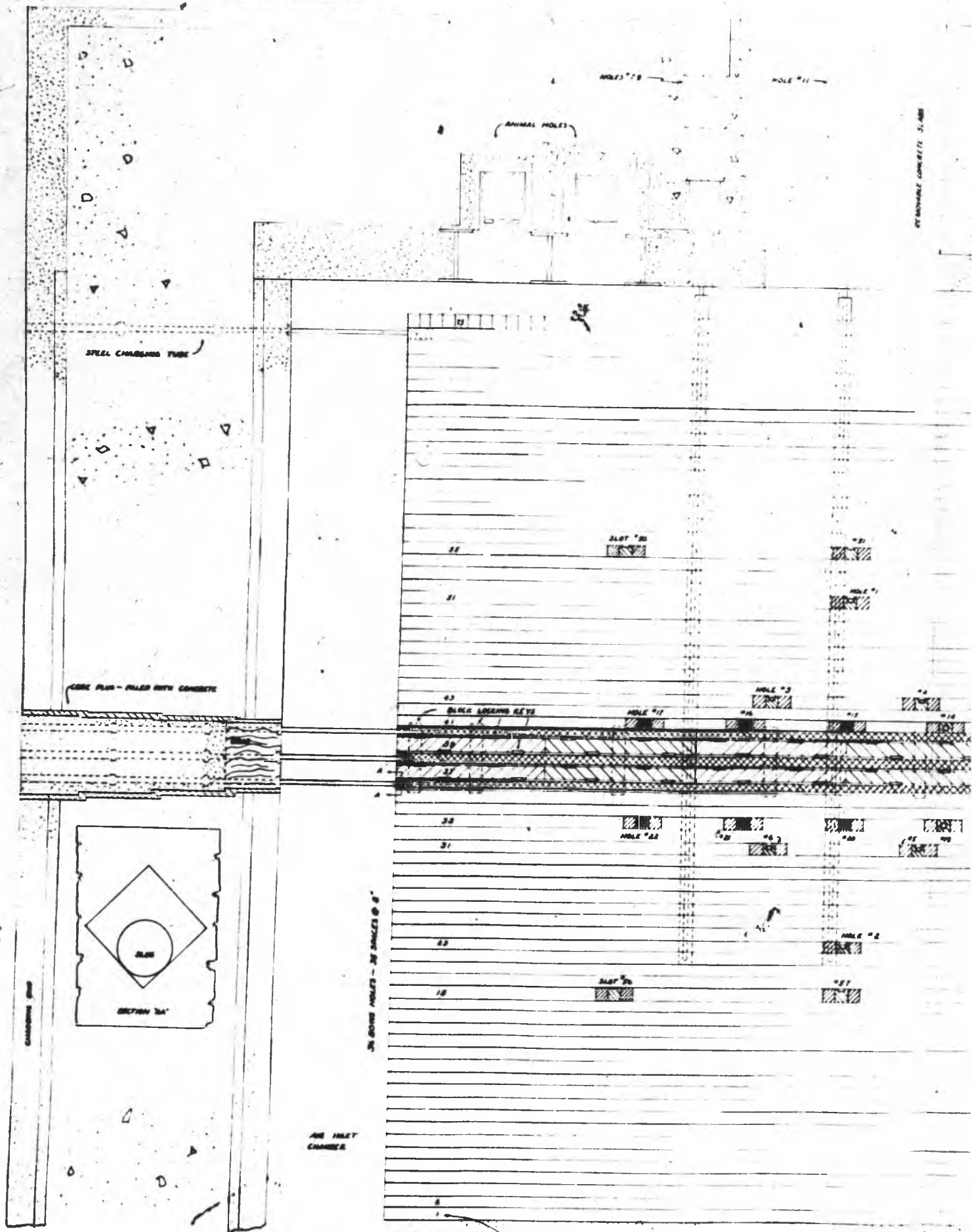

STEEL CHANNEL TUBE

CORE PLAN - FILLED WITH CONCRETE



34 SQUARE HOLES - 30 SIZES @ 8"

THE HOLE CHAMBER

BACK LAYER NUMBERS



REMOVABLE CONCRETE SLAB

MOLES 10 10

MANHOLE POLE

CELLAR

REMOVABLE COBE

COBE PLATE - LEAD FILLED

DISCHARGE CHAMBER

VERTICAL SECTION THRU FILE

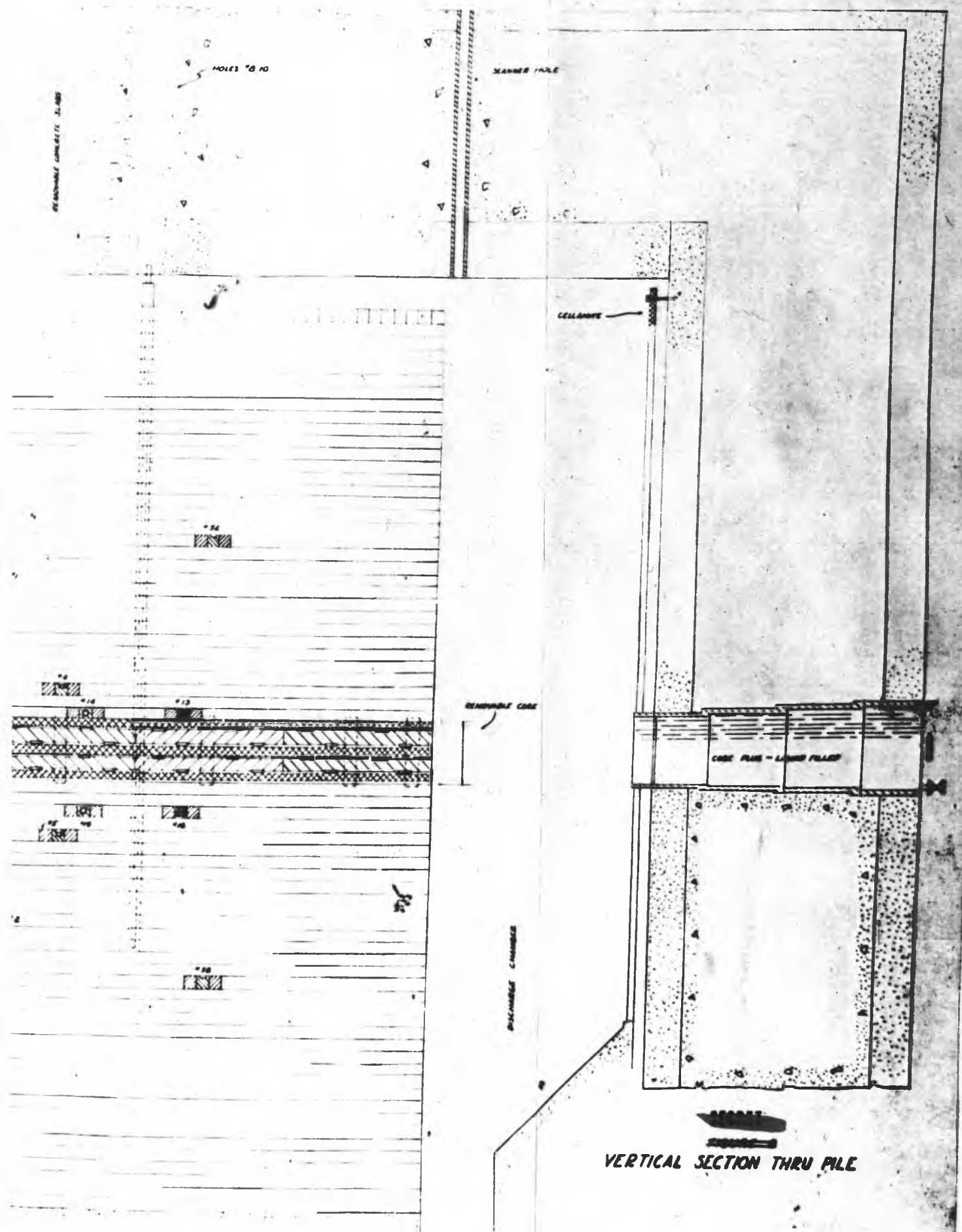

DETAILS OF GRAPHITE MATRIX ASSEMBLY

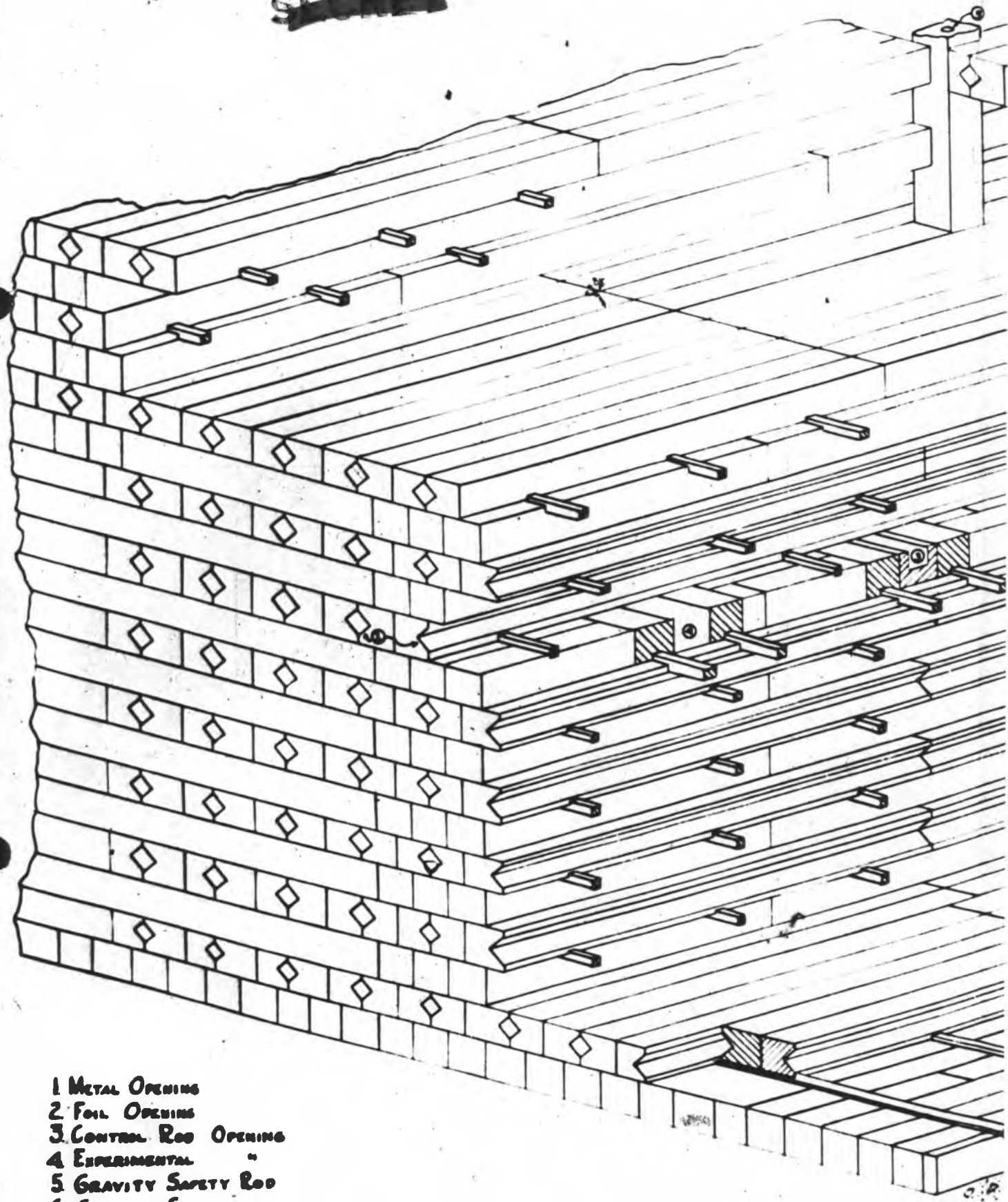

- 1 METAL OPENING
- 2 FOIL OPENING
- 3 CONTROL ROD OPENING
- 4 EXPERIMENTAL "
- 5 GRAVITY SAFETY ROD
- 6 GRAPHITE SPLINE

~~FIGURE 6~~

AILS OF GRAPHITE MATRIX ASSEMBLY

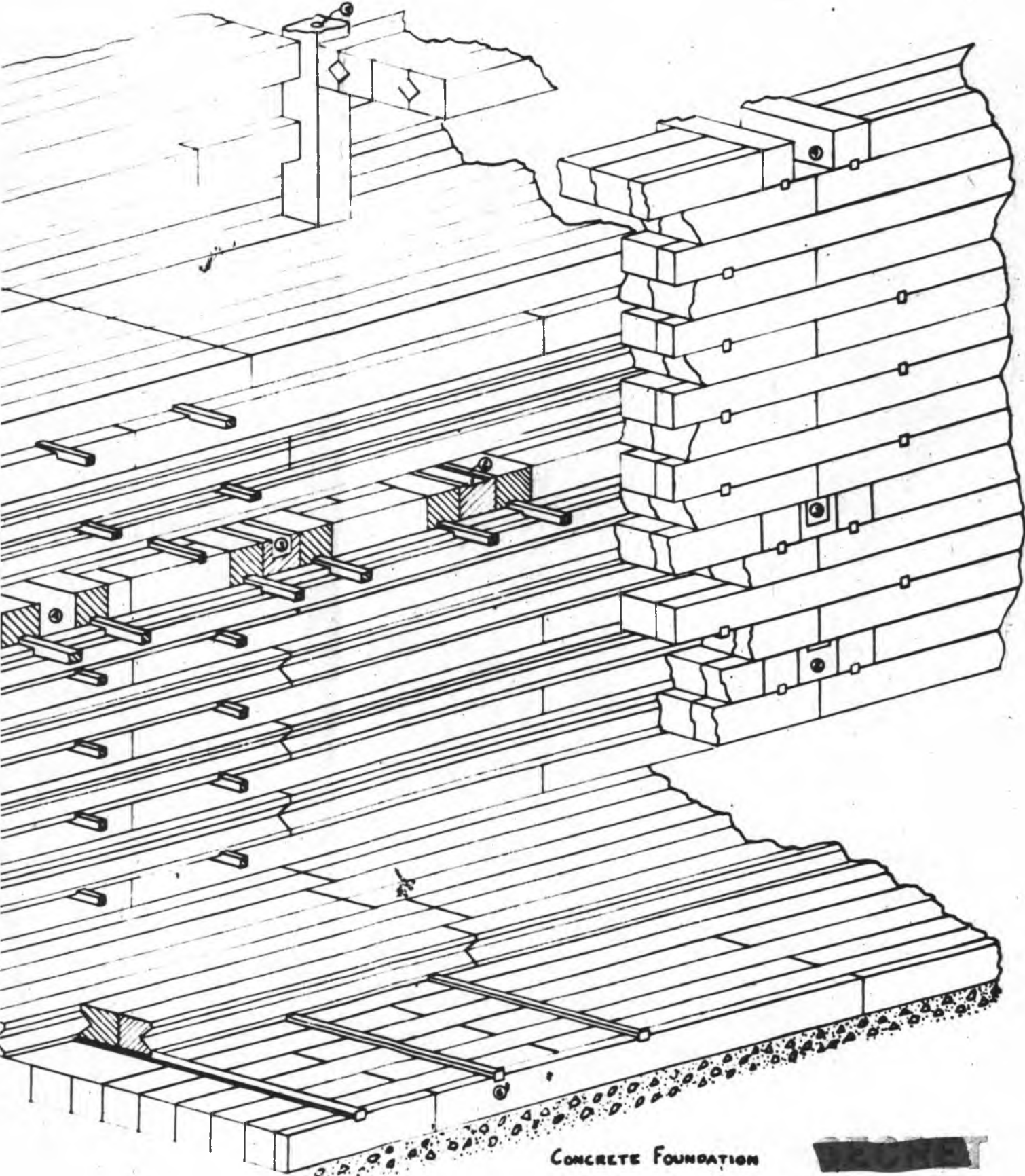

CONCRETE FOUNDATION

**OPENINGS IN METAL CHARGING FACE**

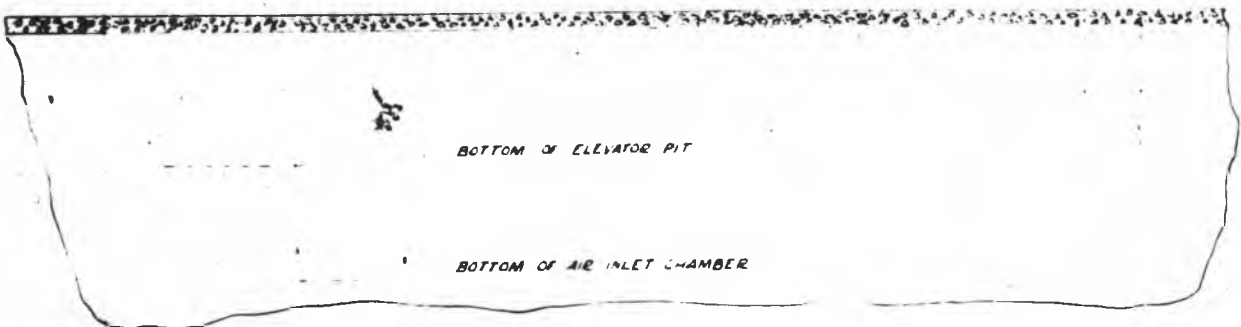
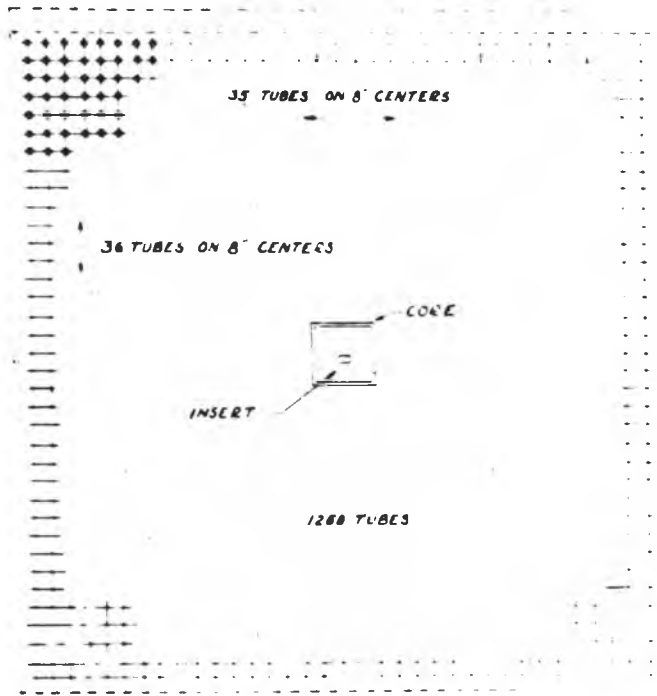

~~FIGURE~~  
ELEVATION OF RIGHT AND LEFT SIDE WALLS

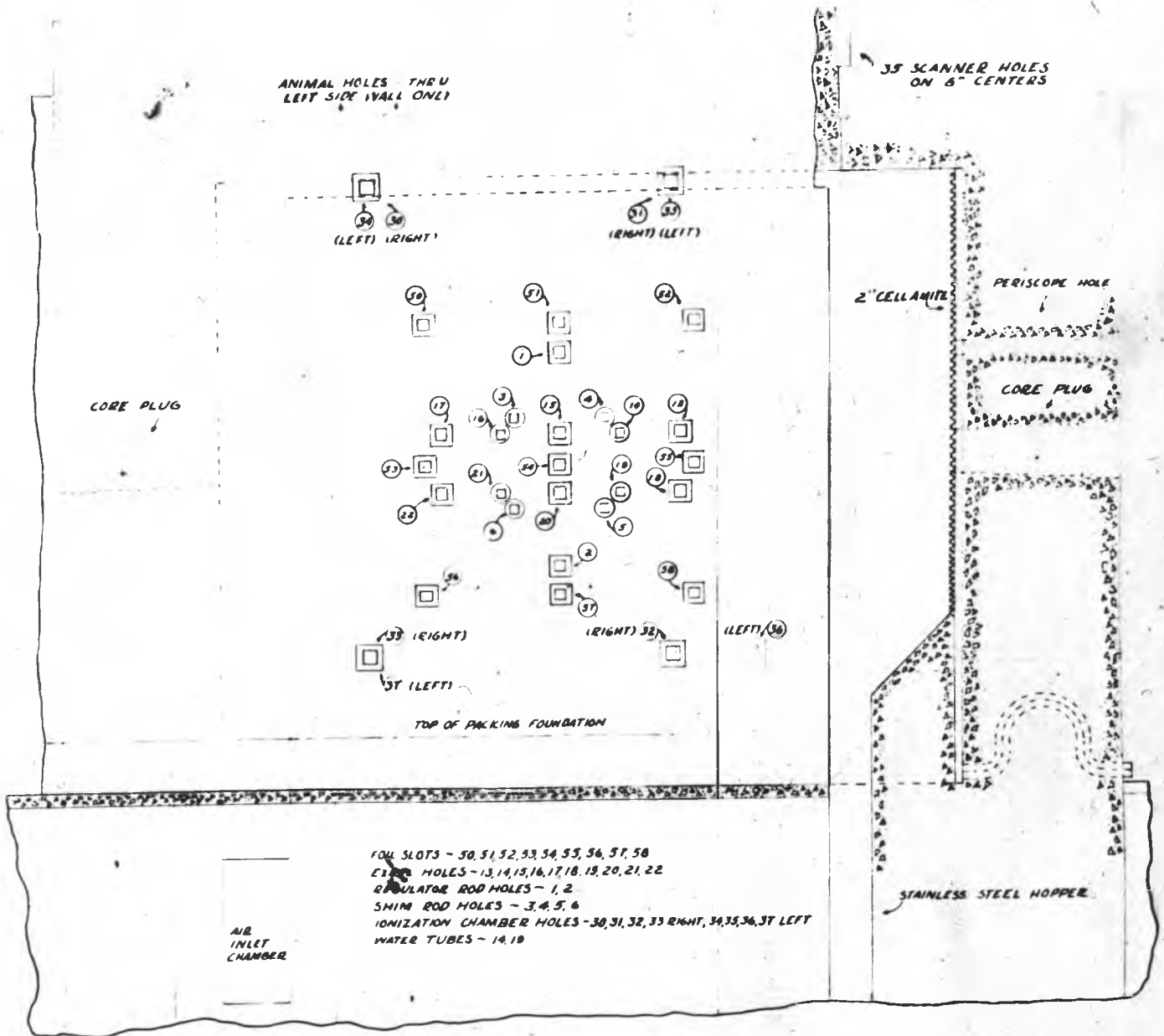

~~SECRET~~

~~SECRET~~  
ELEVATION OF DISCHARGE END WALL

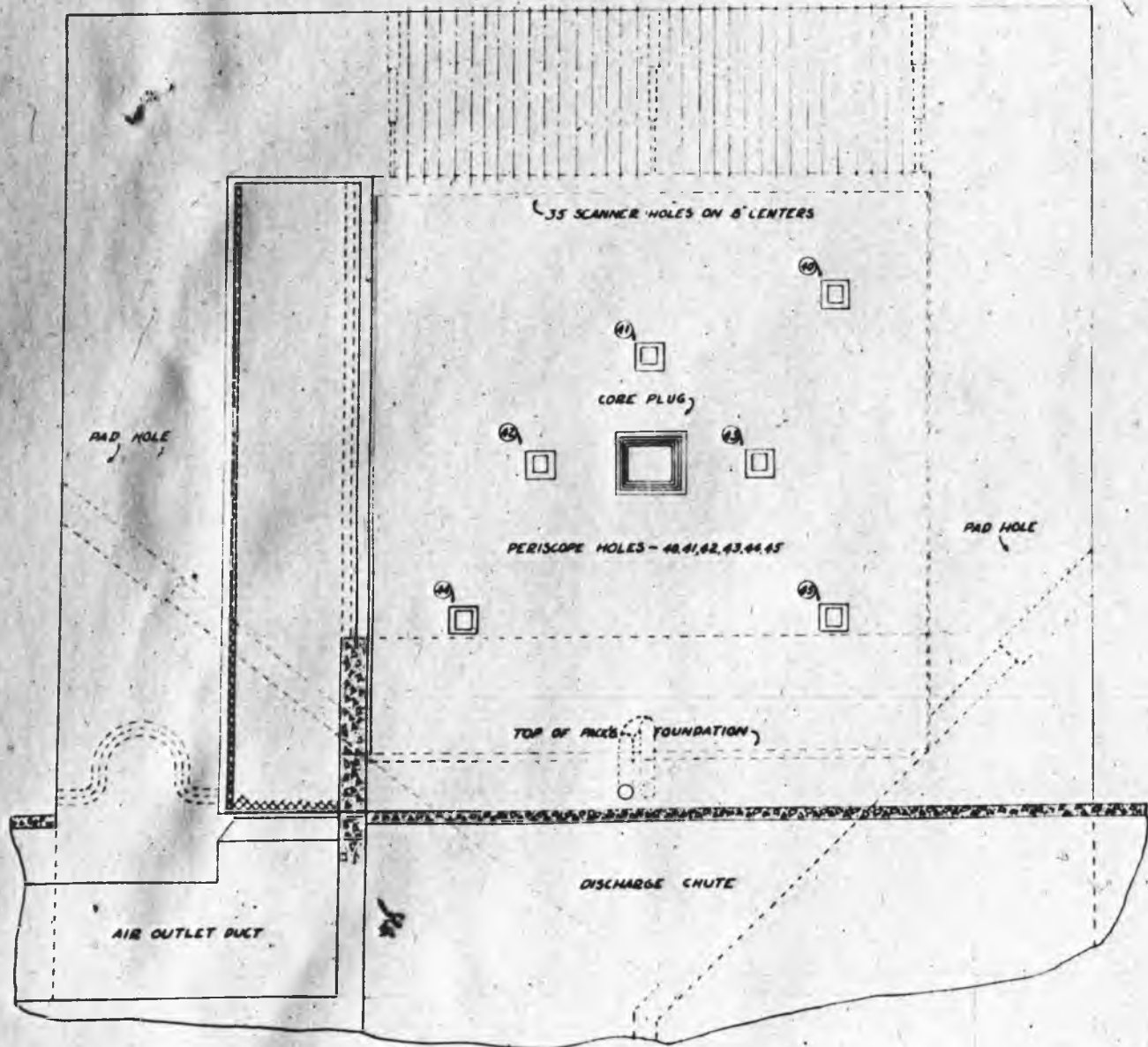

~~SECRET~~

**PLAN VIEW OF PILE TOP**

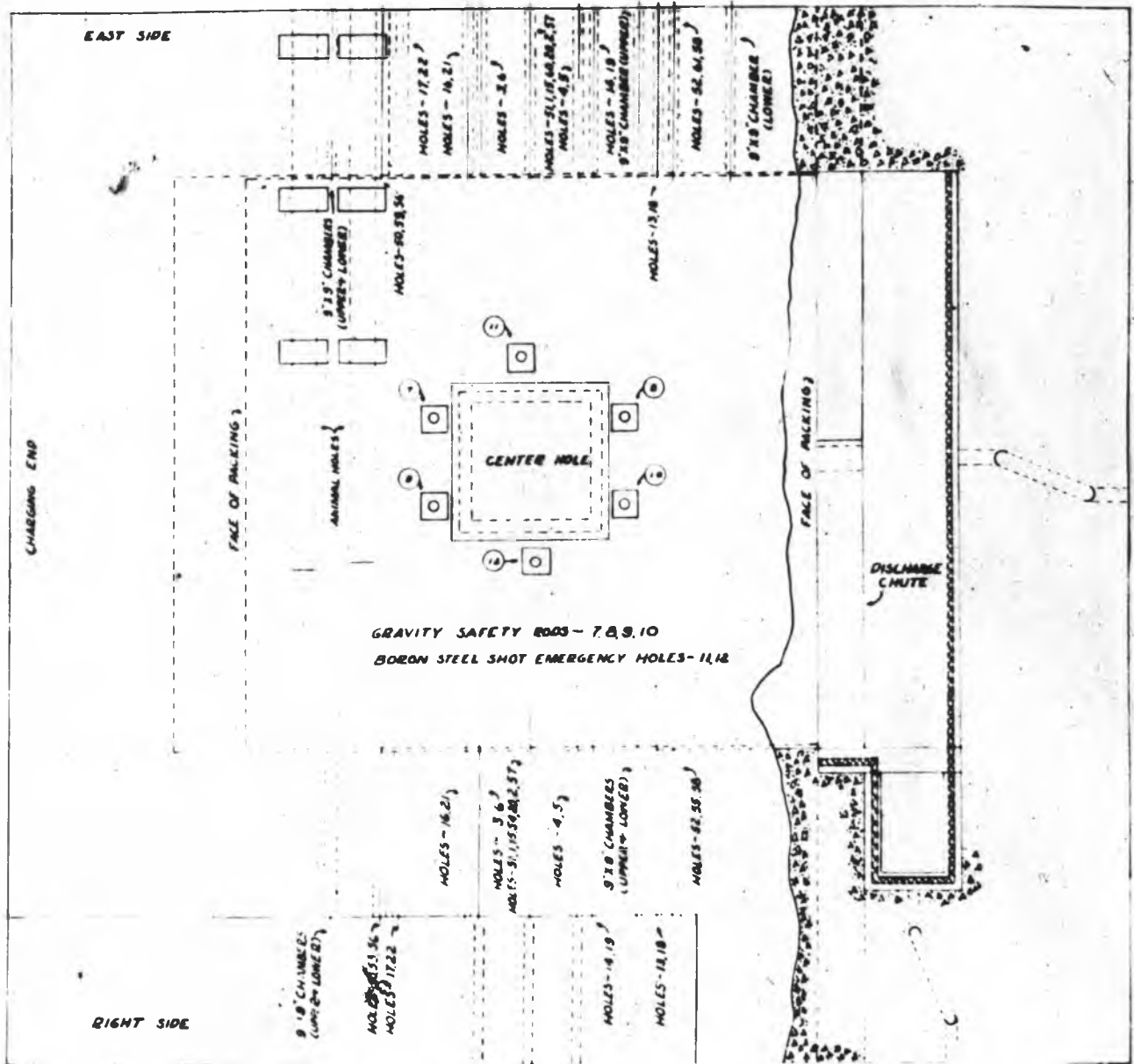

~~SECRET~~

# TYPICAL CLOSURE OF M

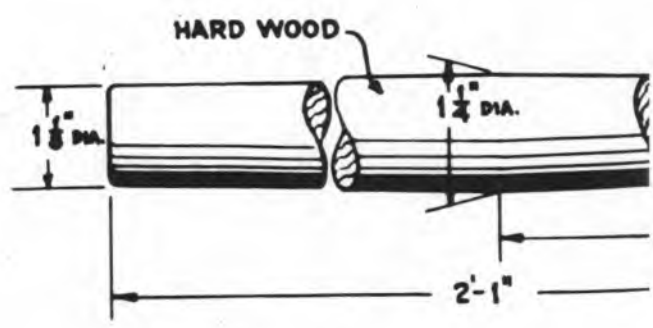
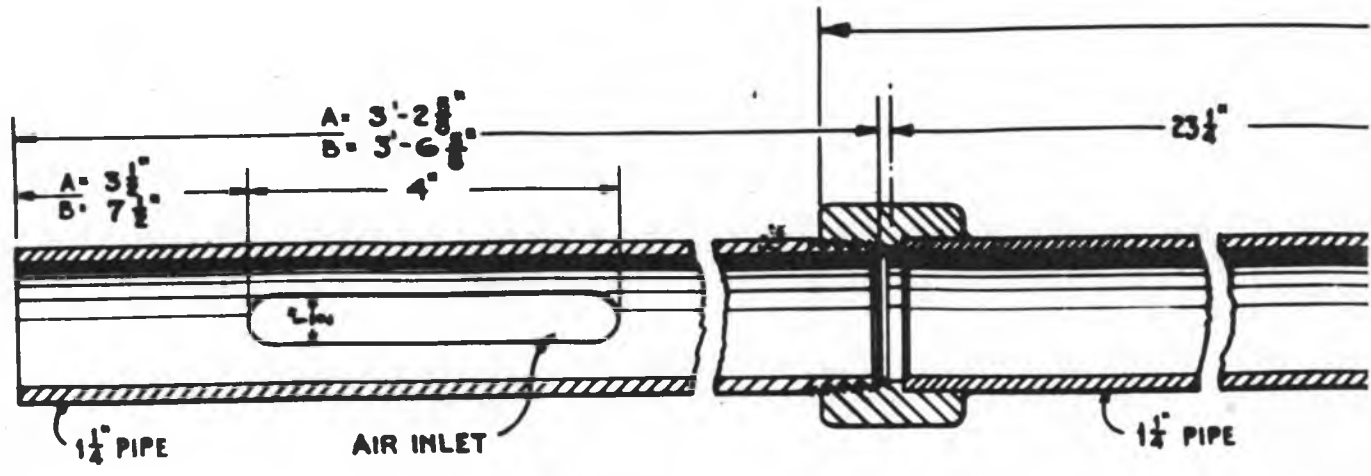



# SURE OF CHARGING END METAL TUBE

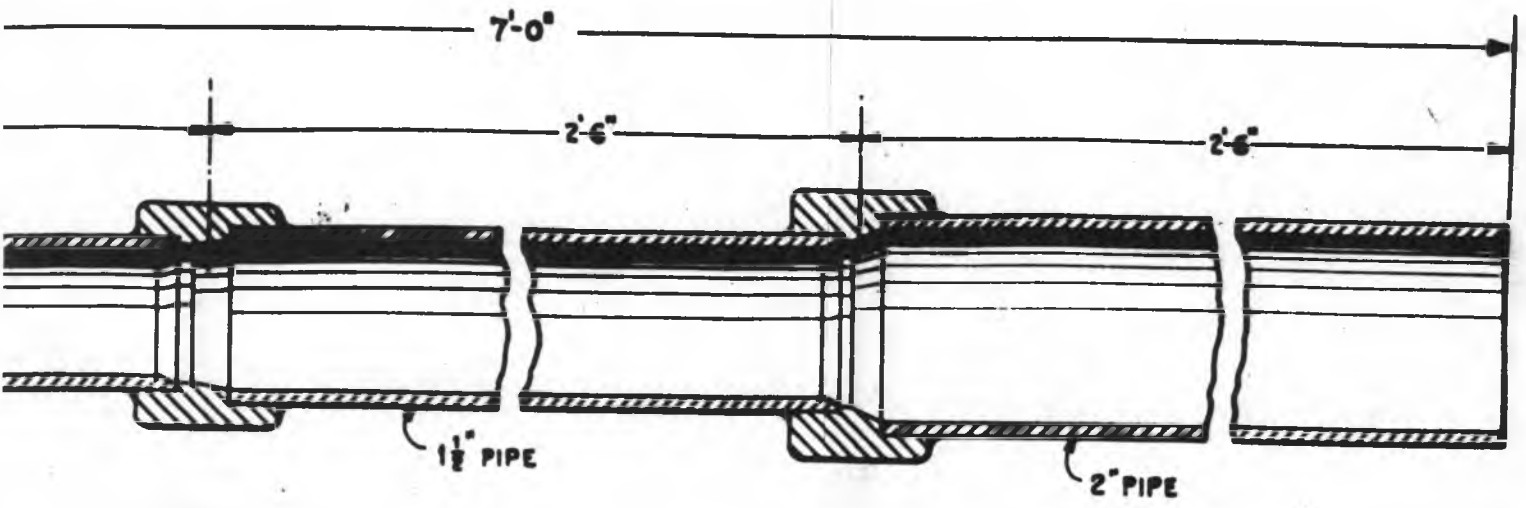

**TUBE**

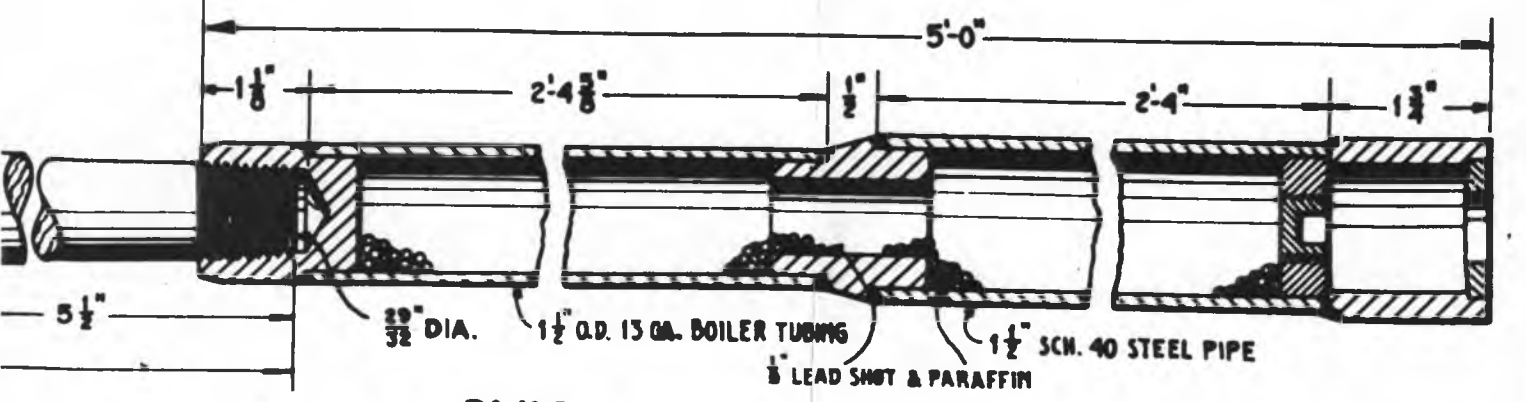

**PLUG**

# GENERAL ARRANGEMENT AIR COOLING SYSTEM

~~SECRET~~

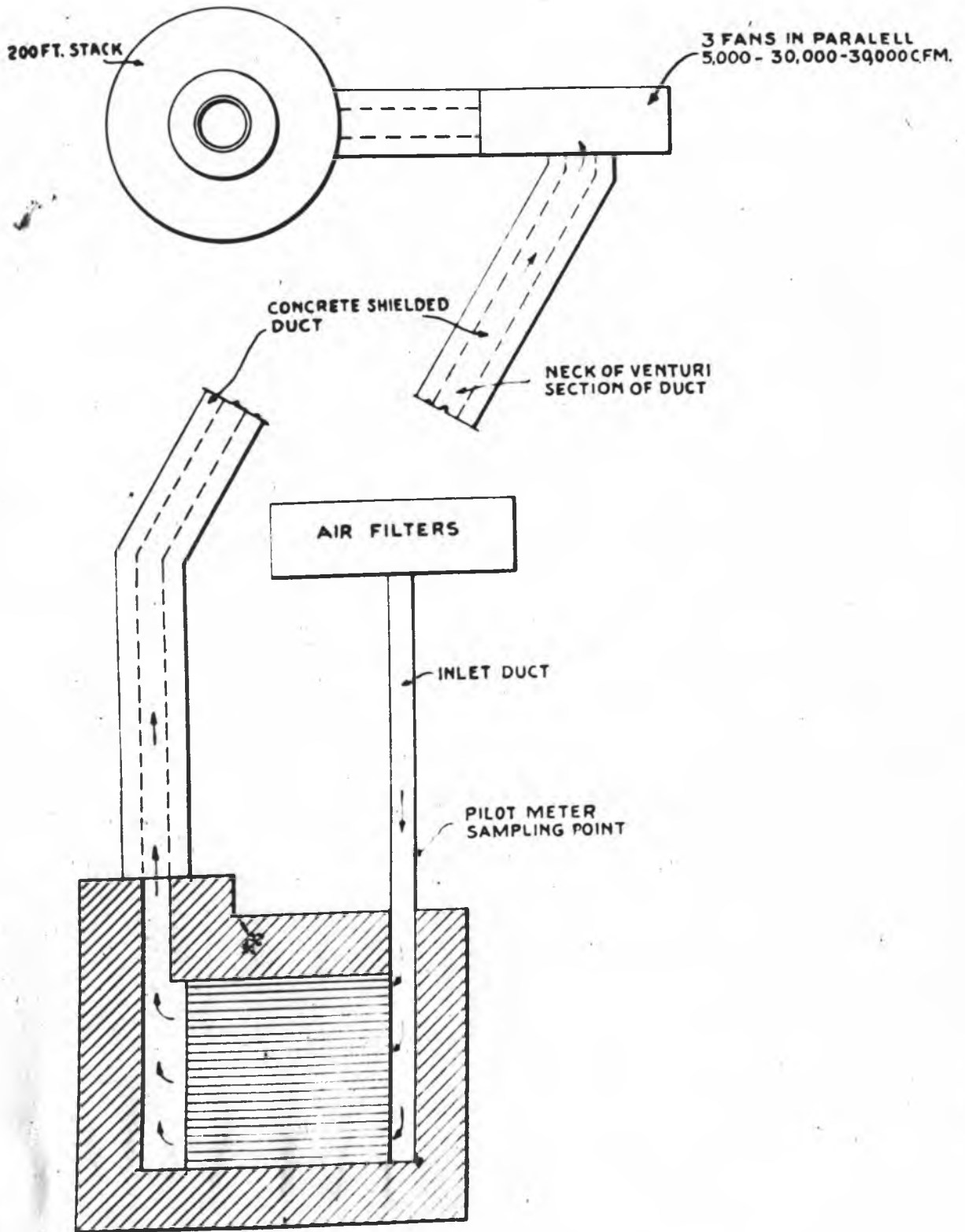

~~SECRET~~

# SECTION THRU SHIM AND REG ROD ASSEMBLY

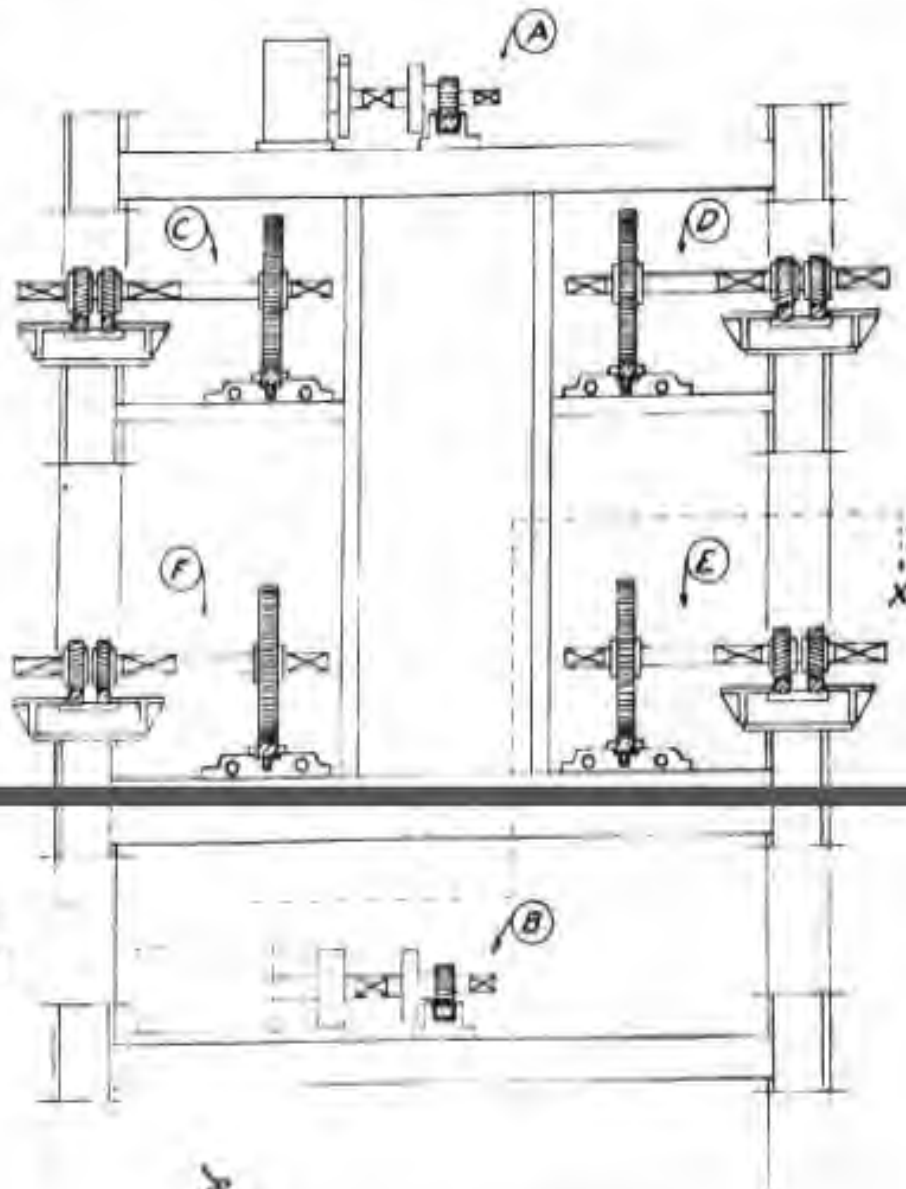

- |   |      |                                  |   |   |   |
|---|------|----------------------------------|---|---|---|
| A | No 1 | REGULATING ROD DRIVING MECHANISM |   |   |   |
| B | No 2 | "                                | " | " | " |
| C | No 3 | SHIM                             | " | " | " |
| D | No 4 | "                                | " | " | " |
| E | No 5 | "                                | " | " | " |
| F | No 6 | "                                | " | " | " |

PLAN OF SHIM

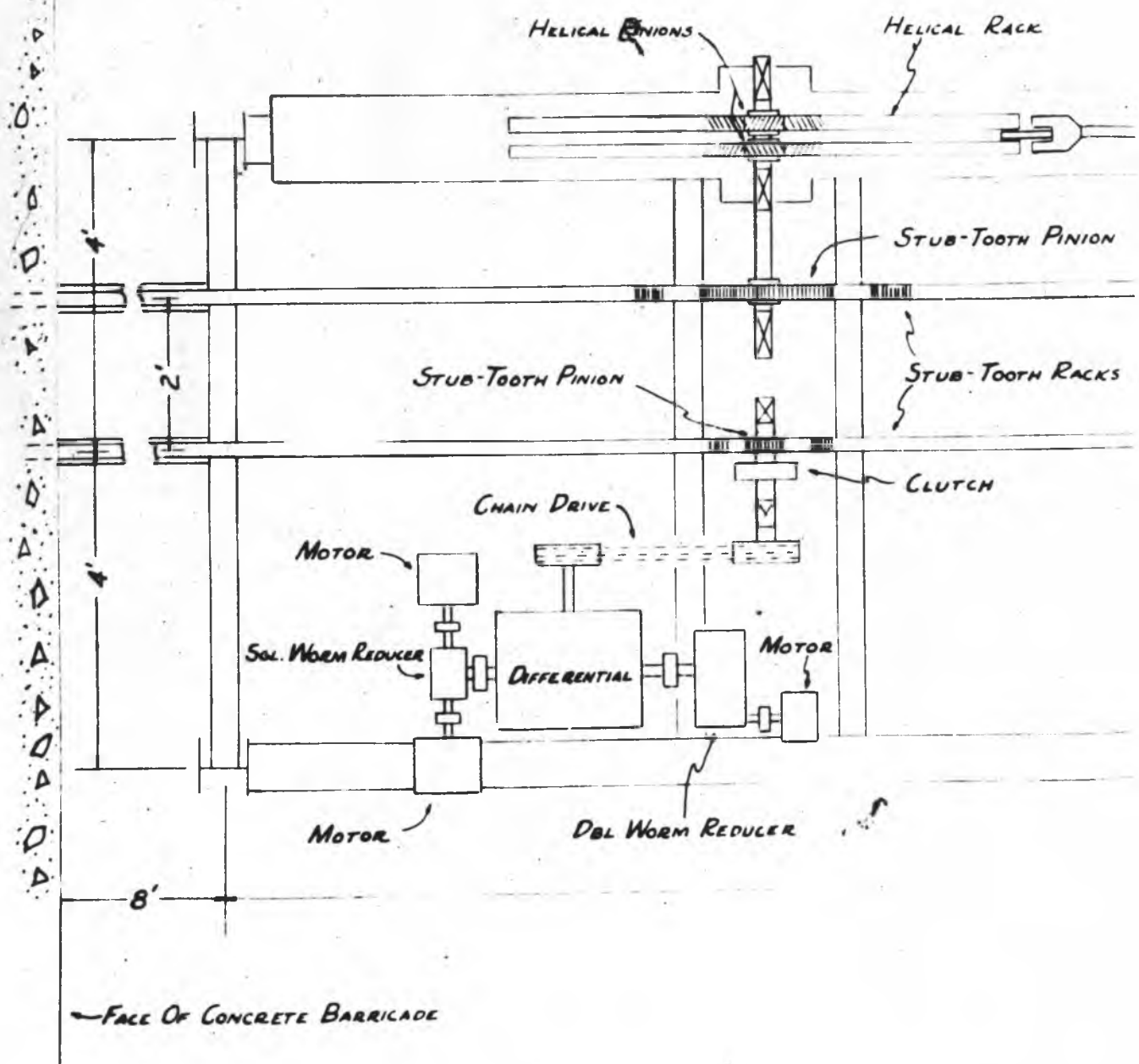

~~FIGURE 1~~

# IM AND REG. ROD ASSEMBLY

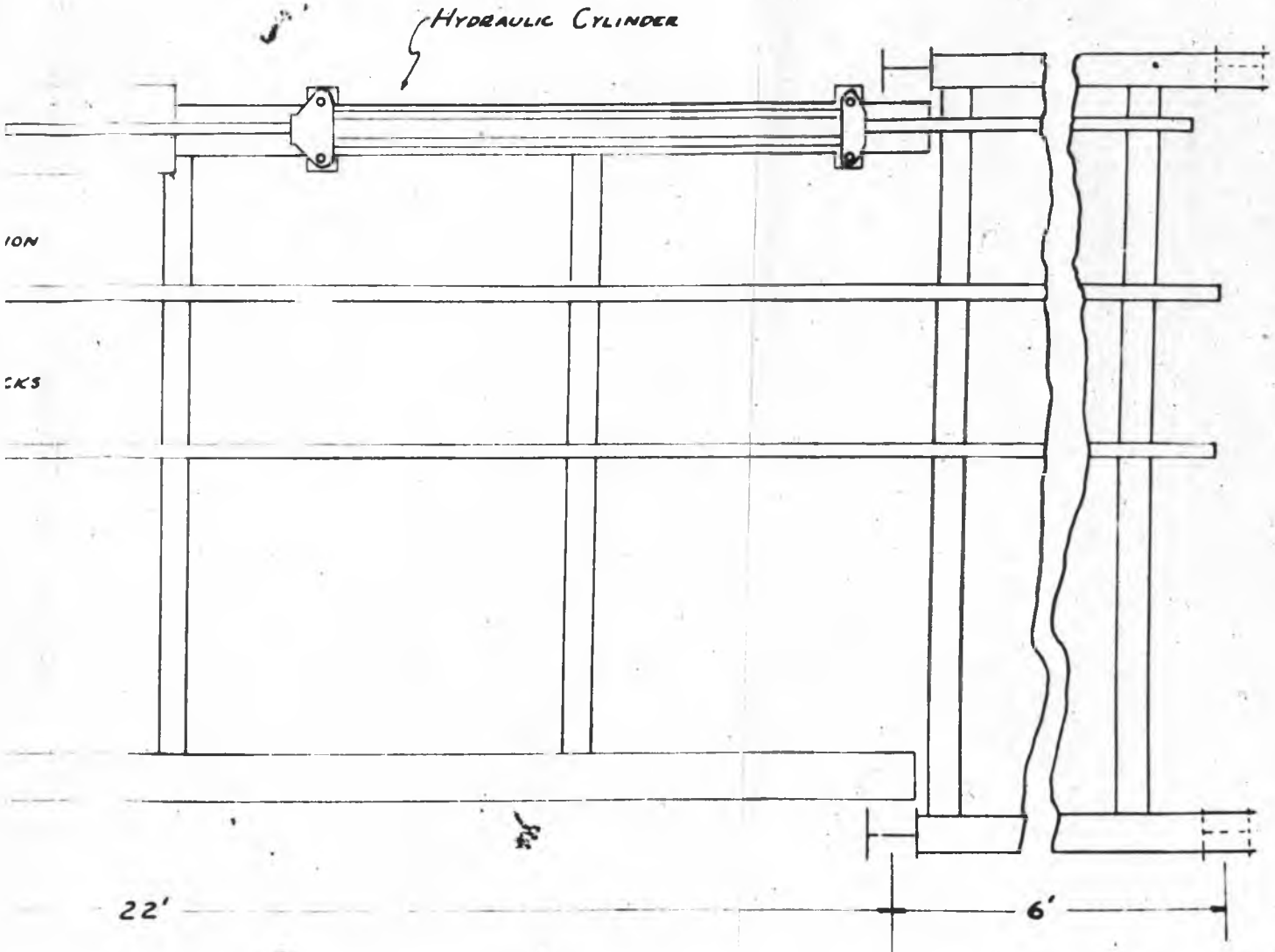

XX - ~~XXXXXXXXXX~~

ELEVATION OF SH

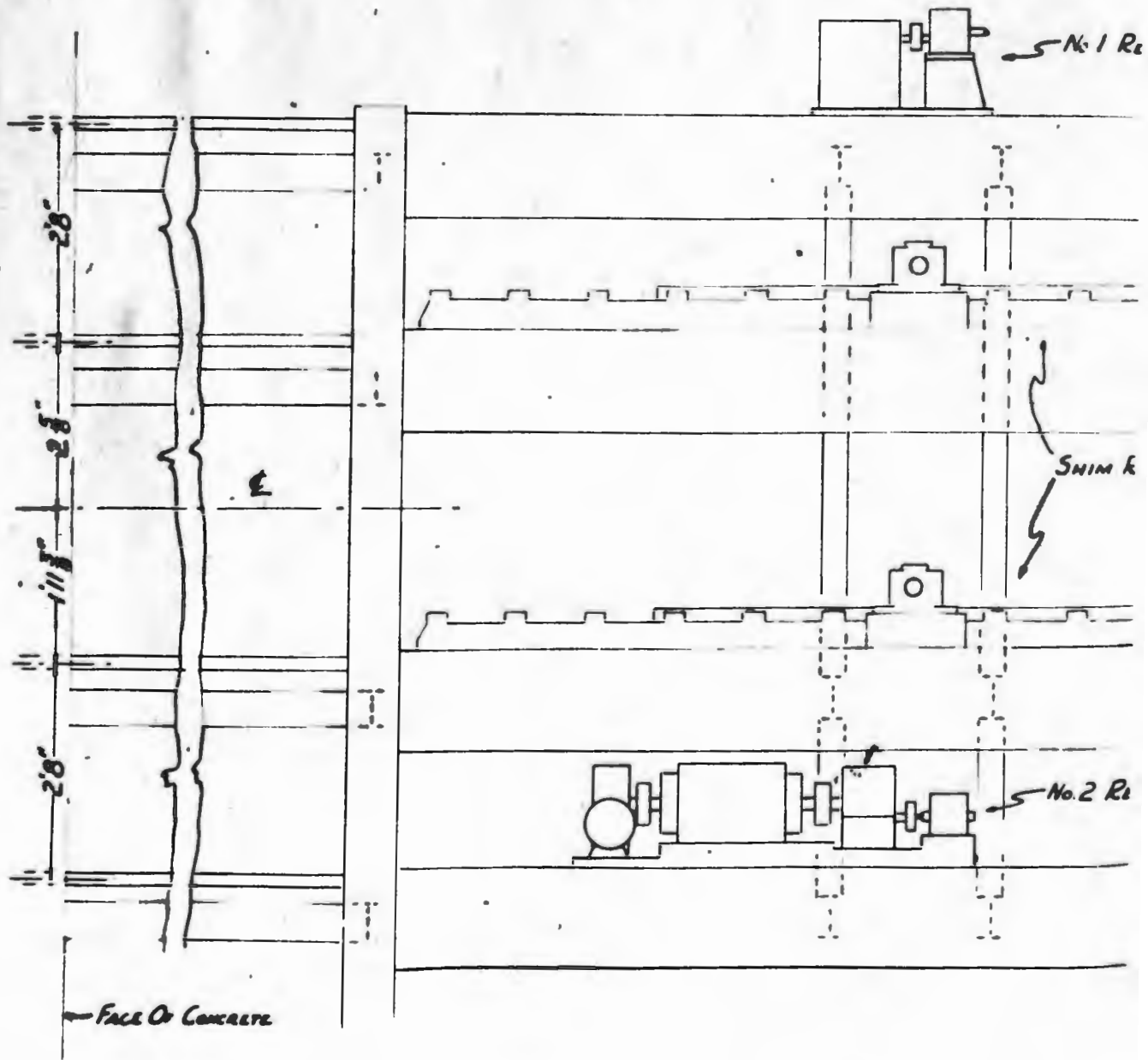

~~SECRET~~

# IIM AND REG ROD ASSEMBLY

1. ROD DRIVING MECHANISM

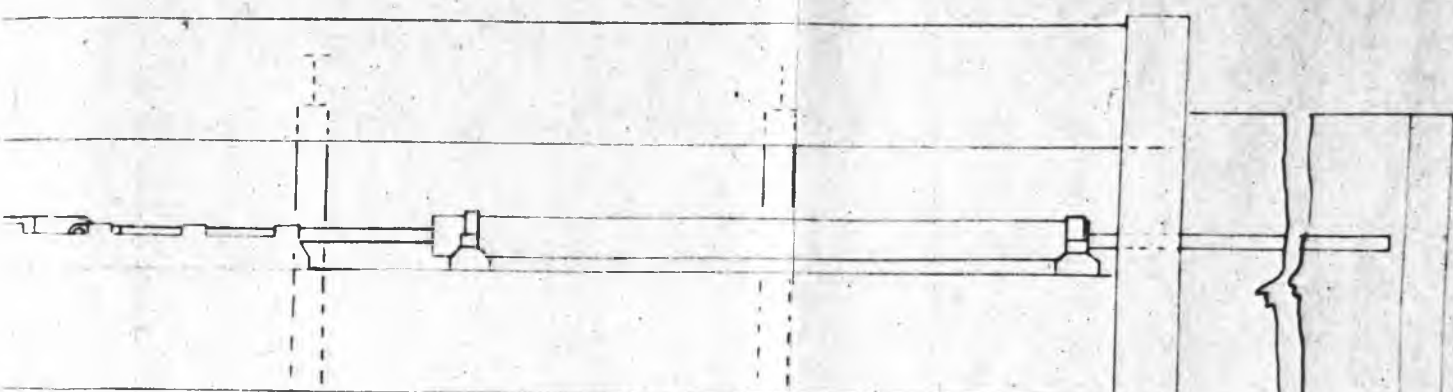

2. DRIVING MECHANISM

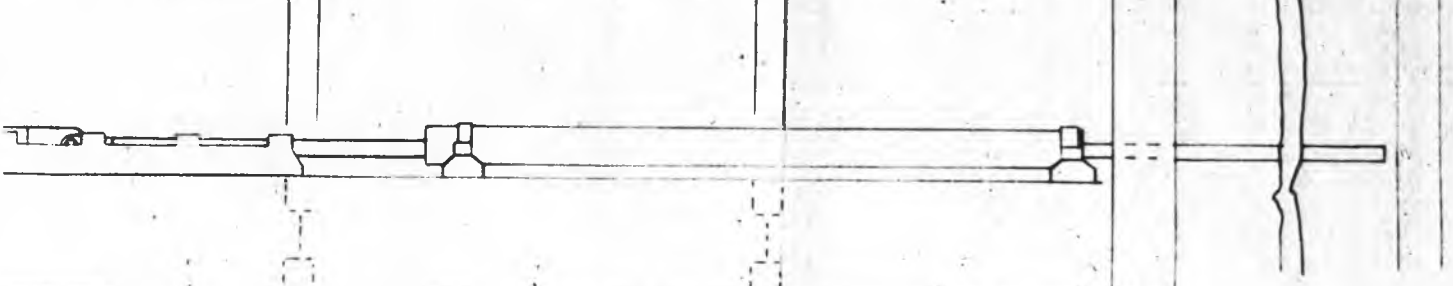

ROD DRIVING MECHANISM

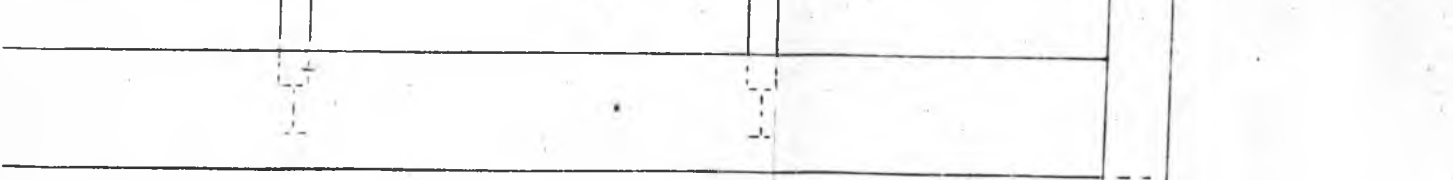

~~SECRET~~

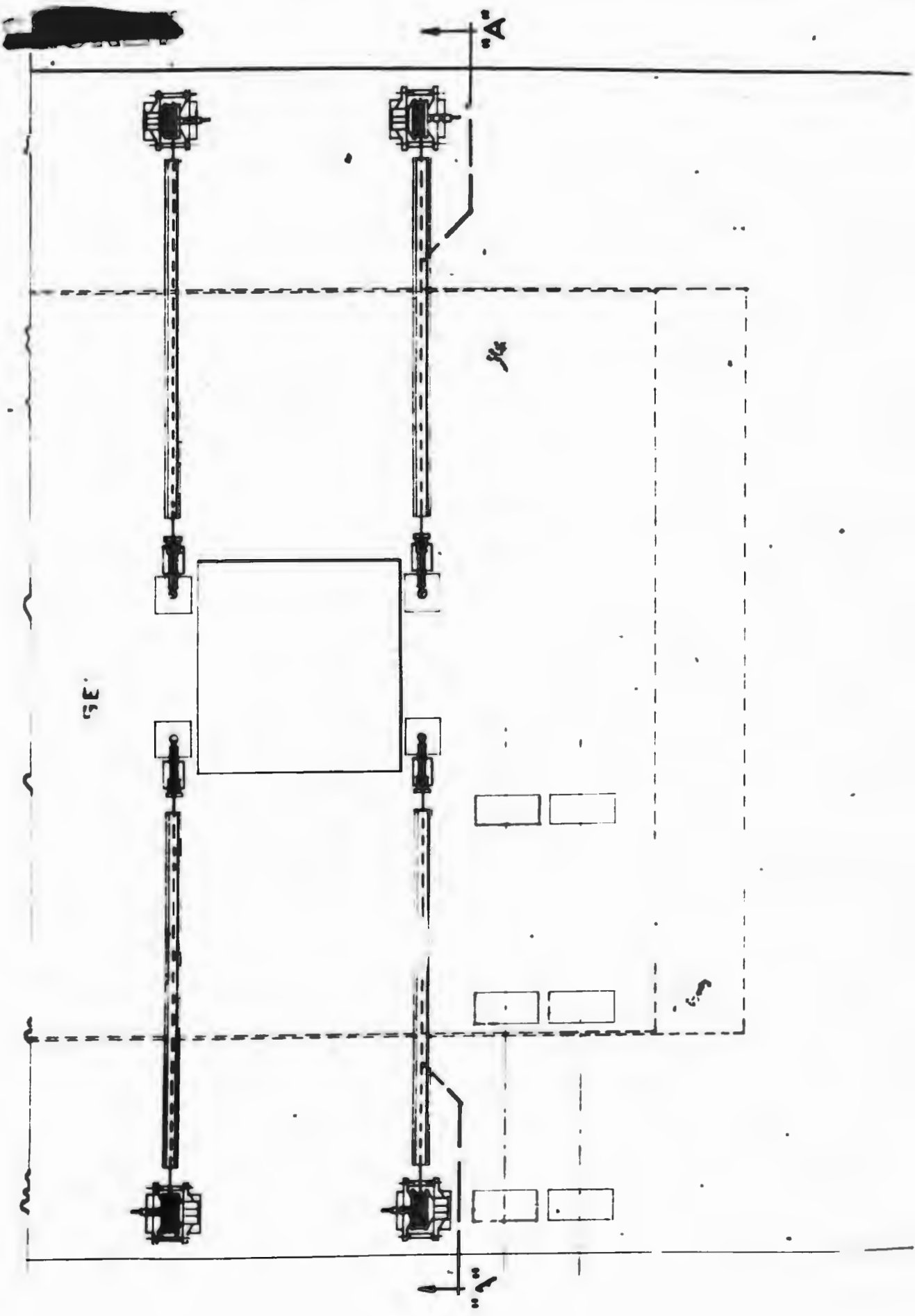



PLAN

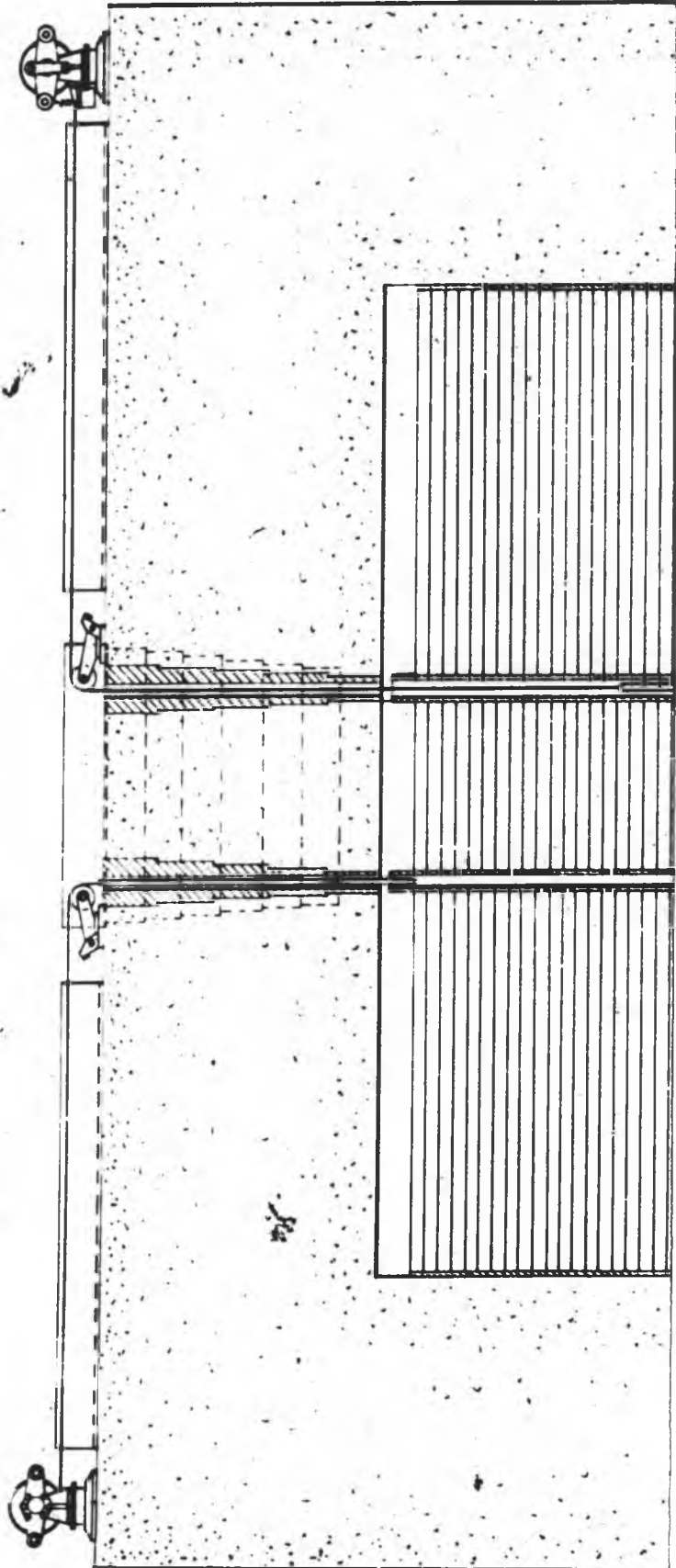

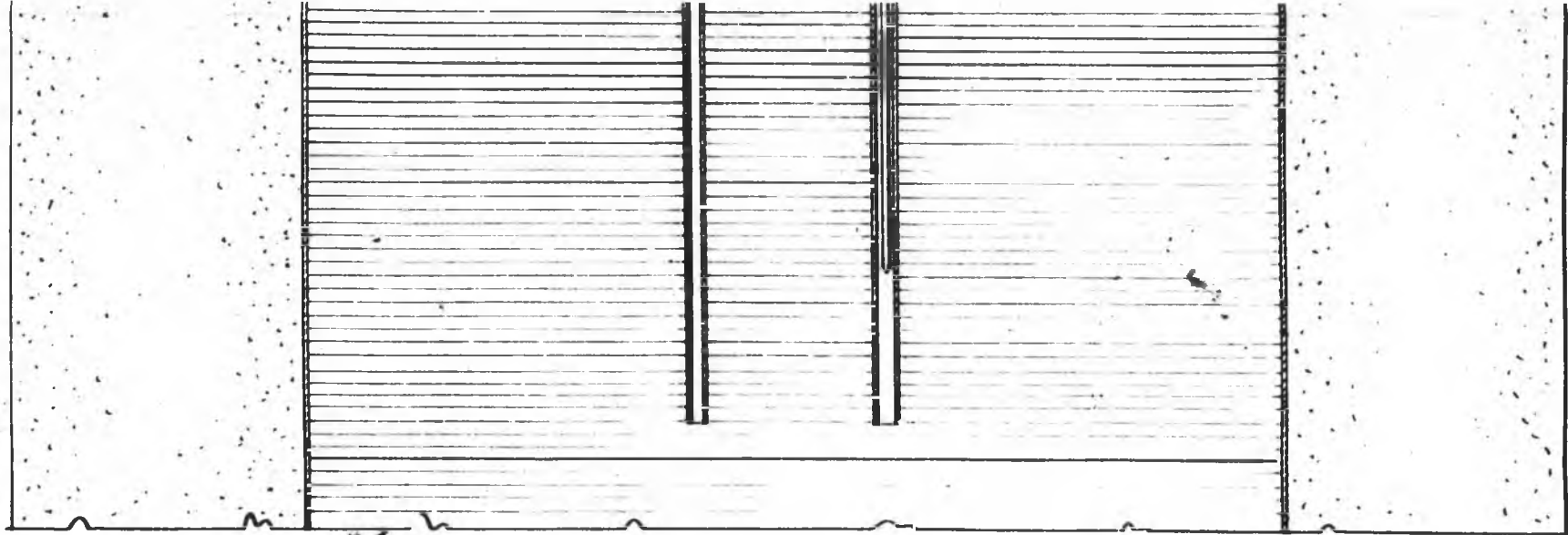

SECTION "A-A"



SHEAVE BRACKET & ROD

GRAVITY SAFETY RODS



~~SECRET~~

~~SECRET~~  
CONTROL PA

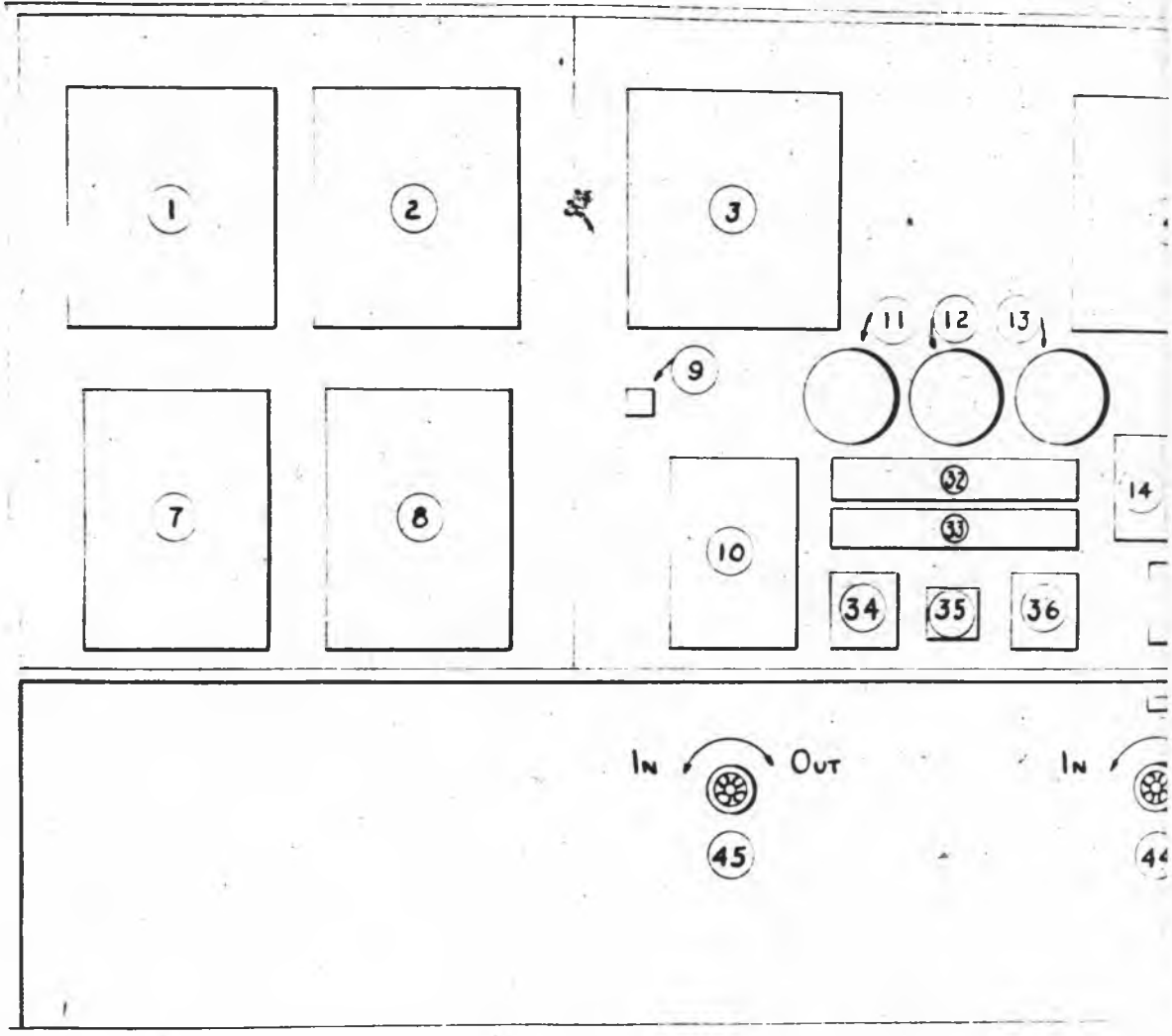

COLOR OF INDICATING LIGHTS  
W ~ WHITE  
G ~ GREEN  
B ~ BLUE  
R ~ RED  
A ~ AMBER

REC-18

CONTROL PANEL

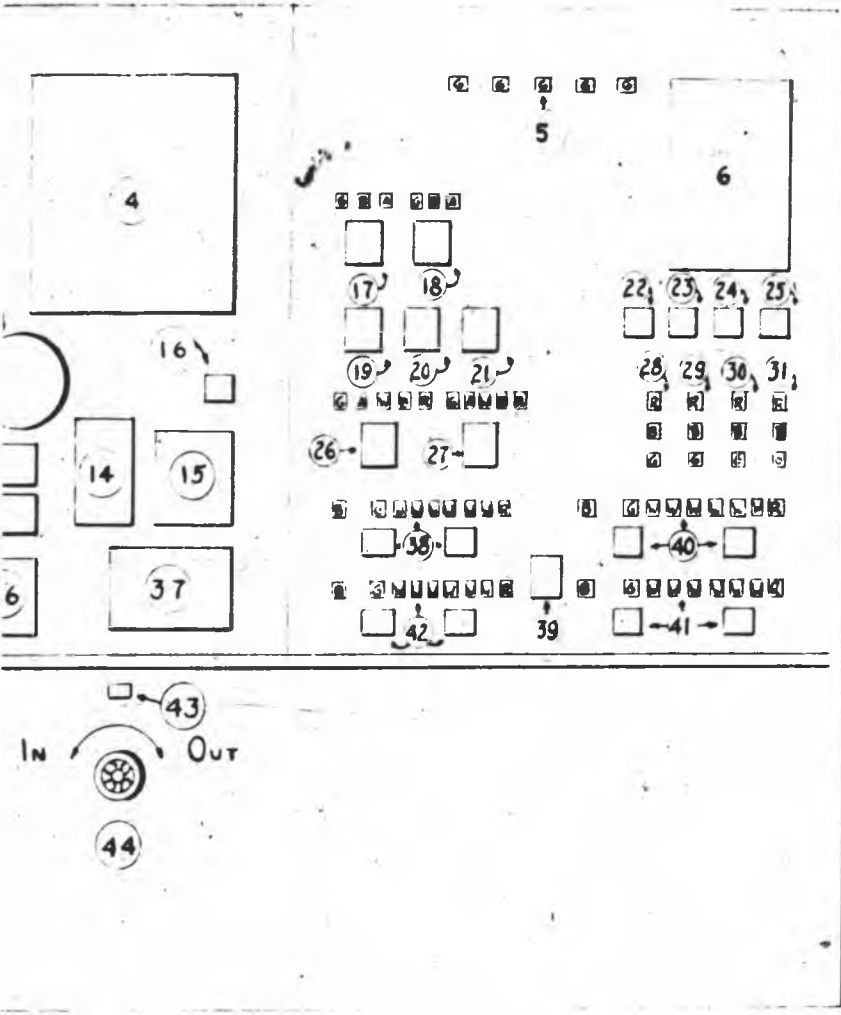

HTS

1. INLET AND EXIT AIR TEMPERATURE RECORDER
2. GRAPHITE AND METAL TEMPERATURE RECORDER
3. REGULATING ROD POSITION RECORDER WITH SELECTION SWITCH
4. SHIM ROD POSITION RECORDER
5. POWER "ON" INDICATING LIGHTS FOR ELECTRICAL CIRCUITS
6. SAFETY ROD POSITION RECORDER
7. INLET AND EXIT AIR FLOW RECORDER
8. PRESSURE DIFFERENTIAL ACROSS PILE RECORDER
9. NO. 1 SAFETY CIRCUIT RELEASE BUTTON
10. OPERATING LEVEL RECORDER
11. NO. 1 REGULATING ROD SELSYN POSITION INDICATOR
12. CLOCK
13. NO. 2 REGULATING ROD SELSYN POSITION INDICATOR
14. " GALV. BALANCING RESISTANCE SELECTOR SWITCHES
15. " " COARSE SLIDWISE ADJUSTMENT
16. " SAFETY CIRCUIT RELEASE BUTTON
17. NO. 3-6 ACCUMULATOR PUMP CONTROL AND ACCUMULATOR LEVEL INDICATING LIGHTS
18. NO. 4-5 " " " " " " " " " "
19. SAFETY ROD LATCHING SOLENOID CONTROL
20. SHIM ROD MAIN POWER CONTROL
21. REGULATING RODS MAIN POWER CONTROL
22. NO. 3-6 SHIM ROD OPERATING PUMP CONTROL
23. NO. 4-5 " " " " " "
24. DC POWER MAIN CONTROL SWITCH
25. INST. " " " " "
26. NO. 1 REGULATING ROD SELECTOR SWITCH AND POSITION INDICATING LIGHTS
27. NO. 2 " " " " " " " " "
28. NO. 7 POSITION INDICATING LIGHTS
29. NO. 8 " " " "
30. NO. 9 " " " "
31. NO. 10 " " " "
32. NO. 1 OPERATING GALVANOMETER SCALE
33. NO. 2 EXPERIMENTAL " "
34. NO. 1 GALVANOMETER SHUNT
35. INTERVAL TIMER AND CONTROL SWITCH
36. NO. 2 GALVANOMETER SHUNT
37. " " VERNIER SLIDWISE ADJUSTMENT
38. NO. 3 SHIM ROD CONTROL SWITCHES AND POSITION INDICATING LIGHTS
39. SHIM ROD SELECTOR SWITCH
40. NO. 4 SHIM ROD CONTROL SWITCHES AND POSITION INDICATING LIGHTS
41. NO. 5 " " " " " " " " "
42. NO. 6 " " " " " " " " "
43. NO. 2 REGULATING ROD MANUAL SLOW SPEED CONTROL
44. " " " " VARIABLE HIGH SPEED CONTROL
45. NO. 1 " " " " " SPEED CONTROL

~~SECRET~~

CELL No 1

- 1- DISSOLVER
- 2- NITRIC SCALE TANK
- 3- WATER MEASURE TANK

CELL No 2

- 1- PRECIPITATOR
- 2- CENTRIFUGE CATCH TANK
- 3- CENTRIFUGE
- 4- NEUTRALIZER
- 5- PRECIPITATOR WEIGH TANK
- 6- CENTRIFUGE WEIGH TANK
- 7- CHARGE FUNNEL TO PRECIPITATOR

CELL No 3

- 1- PRECIPITATOR
- 2- CENTRIFUGE CATCH TANK
- 3- CENTRIFUGE
- 4- NEUTRALIZER
- 5- PRECIPITATOR WEIGH TANK
- 6- CENTRIFUGE WEIGH TANK
- 7- CHARGE FUNNEL TO PRECIPITATOR

CELL No 4

- 1- PRECIPITATOR
- 2- CENTRIFUGE CAT
- 3- CENTRIFUGE
- 4- NEUTRALIZER
- 5- PRECIPITATOR W
- 6- CENTRIFUGE WE
- 7- CHARGE FUNNEL TO

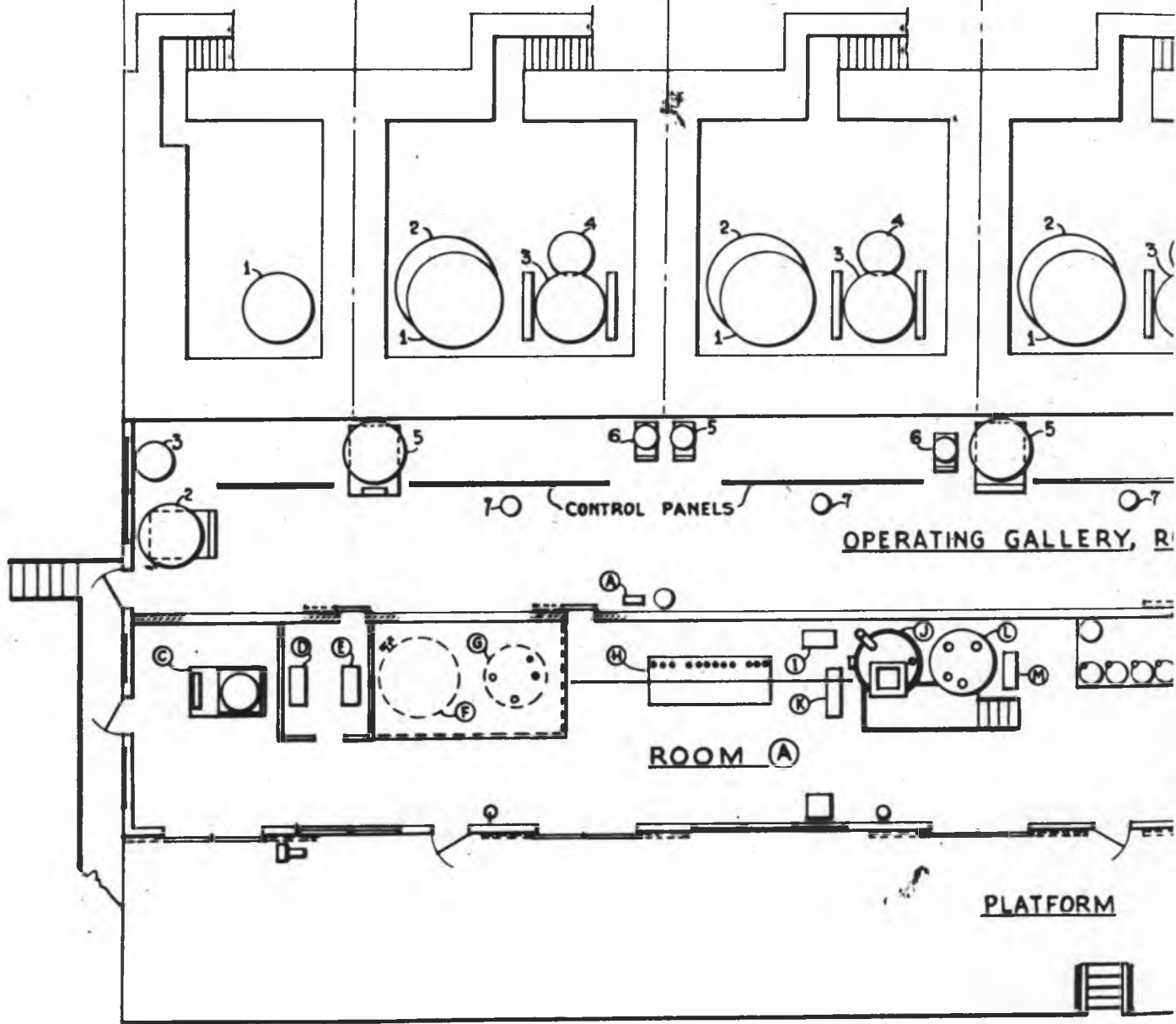

PLAN

CELL N°5

- 1-NEUTRALIZER
- 2-CENTRIFUGE
- 3-PRECIPITATOR
- 4-CENTRIFUGE CATCH TANK
- 5-SKIMMER TANK
- 6-NEUTRALIZER WEIGH TANK
- 7-CENTRIFUGE WEIGH TANK
- 8-PRECIPITATOR WEIGH TANK
- 9-CHARGE FUNNEL TO PRECIPITATOR

H TANK  
IGH TANK  
3H TANK  
RECIPITATOR

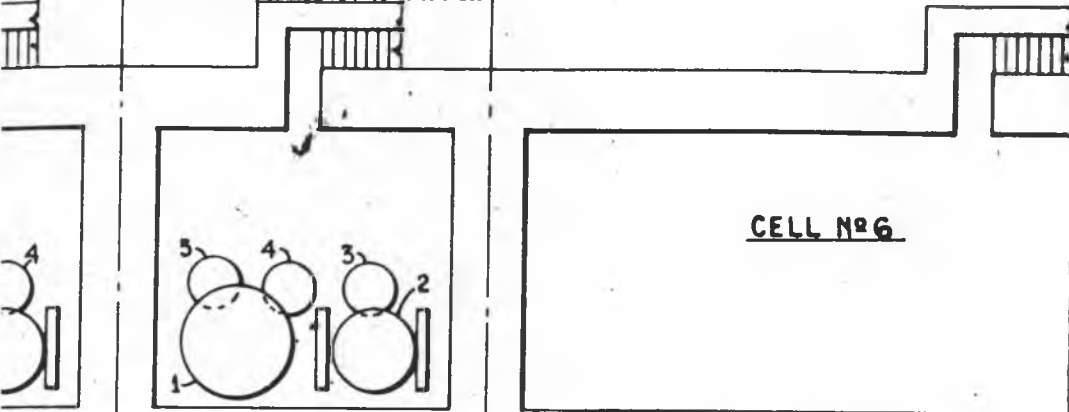

CELL N°6

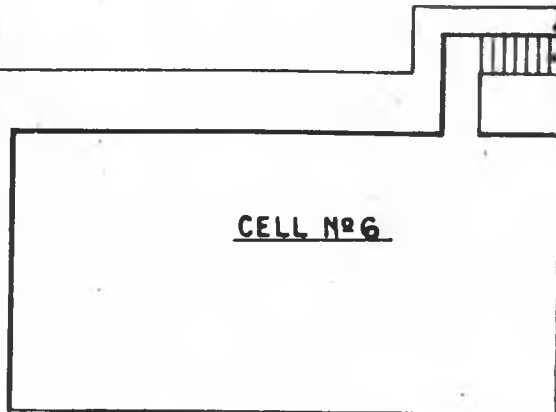

OM (C)

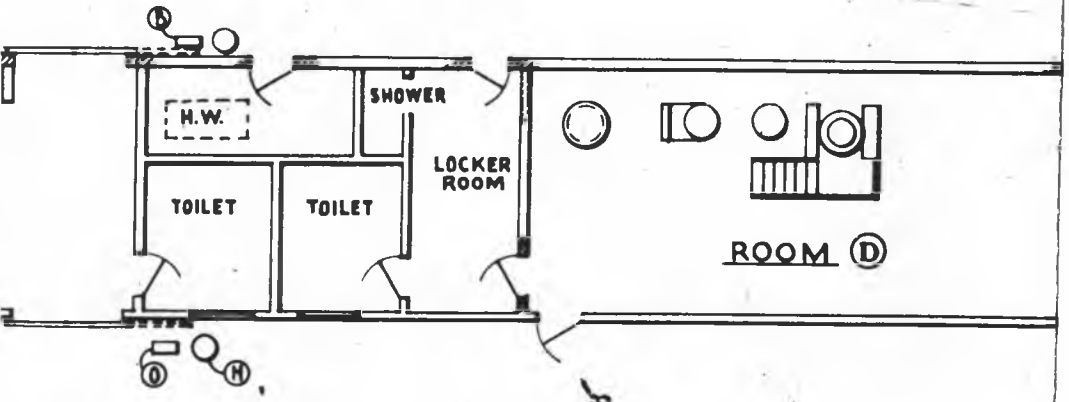

~~SECRET~~

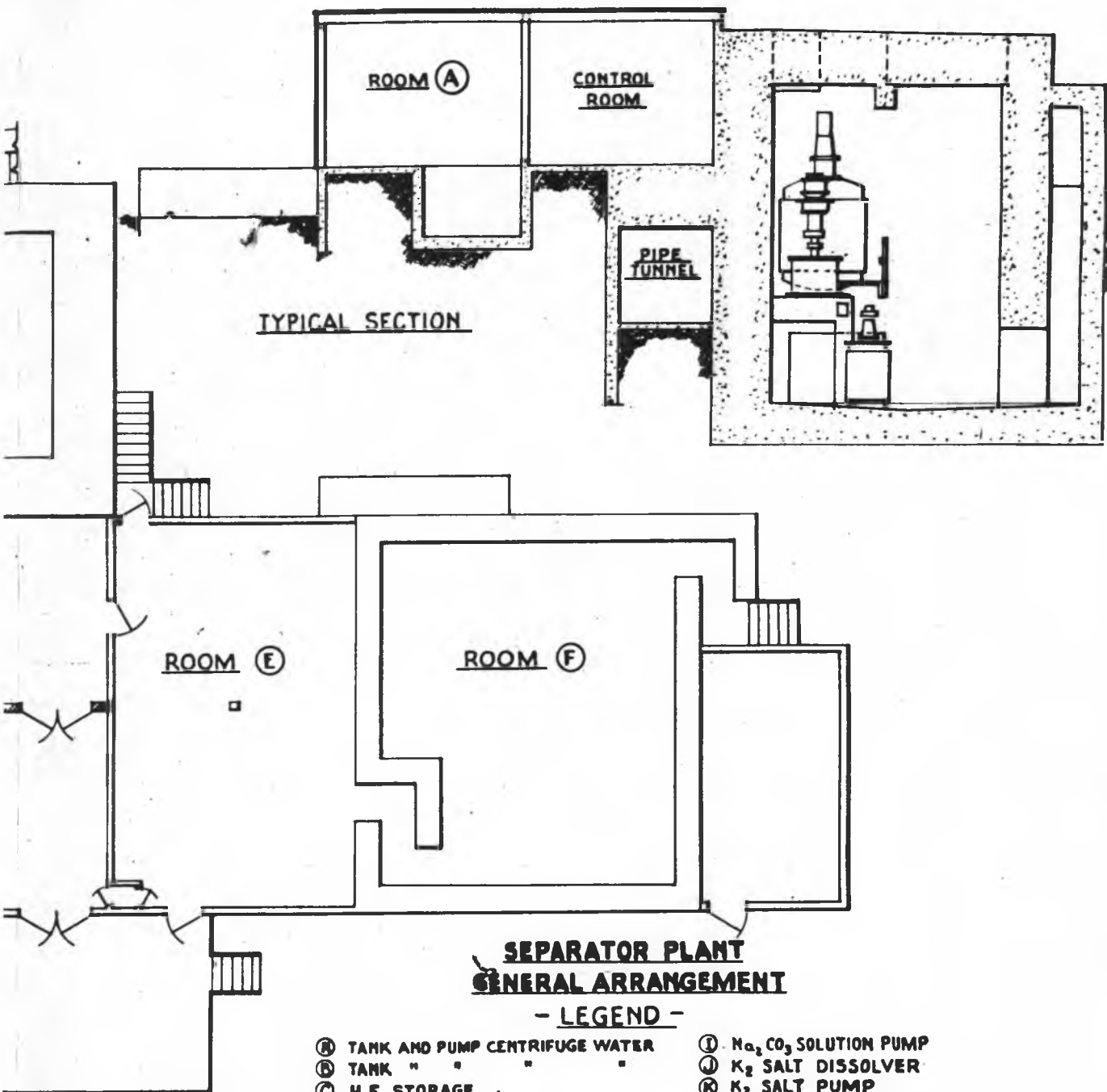

**SEPARATOR PLANT  
GENERAL ARRANGEMENT**

**- LEGEND -**

- |   |   |
|---|---|
| Ⓐ TANK AND PUMP CENTRIFUGE WATER                                | Ⓜ Na <sub>2</sub> CO <sub>3</sub> SOLUTION PUMP |
| Ⓑ TANK " " " "  | Ⓝ K <sub>2</sub> SALT DISSOLVER                 |
| Ⓒ H.F. STORAGE  | Ⓞ K <sub>2</sub> SALT PUMP                      |
| Ⓓ H.N.O <sub>3</sub> PUMP                                       | Ⓛ POSSIBLE FORMIC STORAGE                       |
| Ⓔ H <sub>3</sub> PO <sub>4</sub> & H.N.O <sub>3</sub> WASH PUMP | Ⓜ " " PUMP                                      |
| Ⓕ H <sub>3</sub> PO <sub>4</sub> & " " STORAGE                  | Ⓢ H <sub>3</sub> PO <sub>4</sub> STORAGE        |
| Ⓖ H.N.O <sub>3</sub> STORAGE                                    | Ⓣ H <sub>3</sub> PO <sub>4</sub> PUMP           |
| Ⓚ Na <sub>2</sub> CO <sub>3</sub> DISSOLVER                     |   |



~~FIGURE~~  
CONTROL PANEL - CELLS 2,3,4

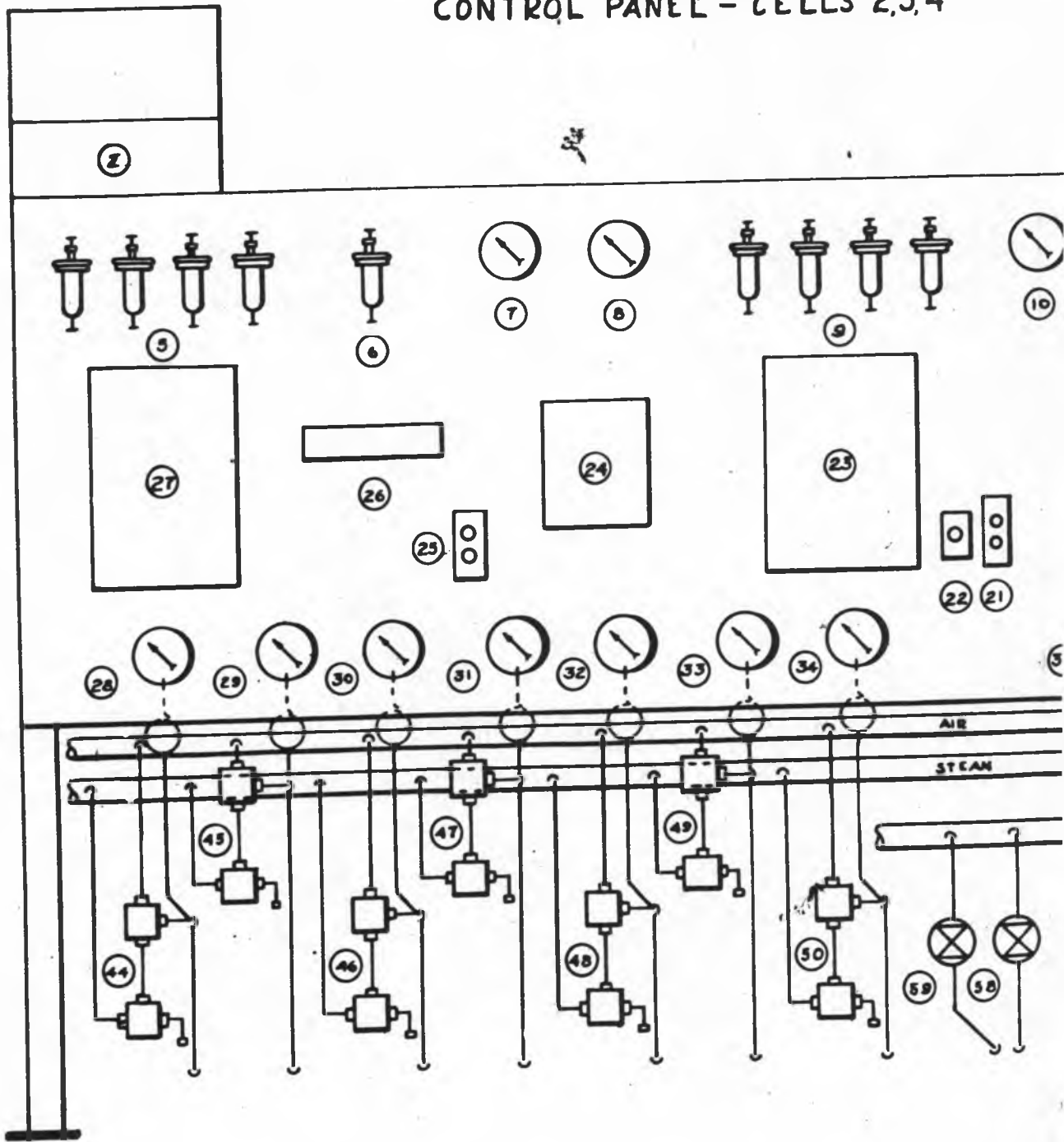

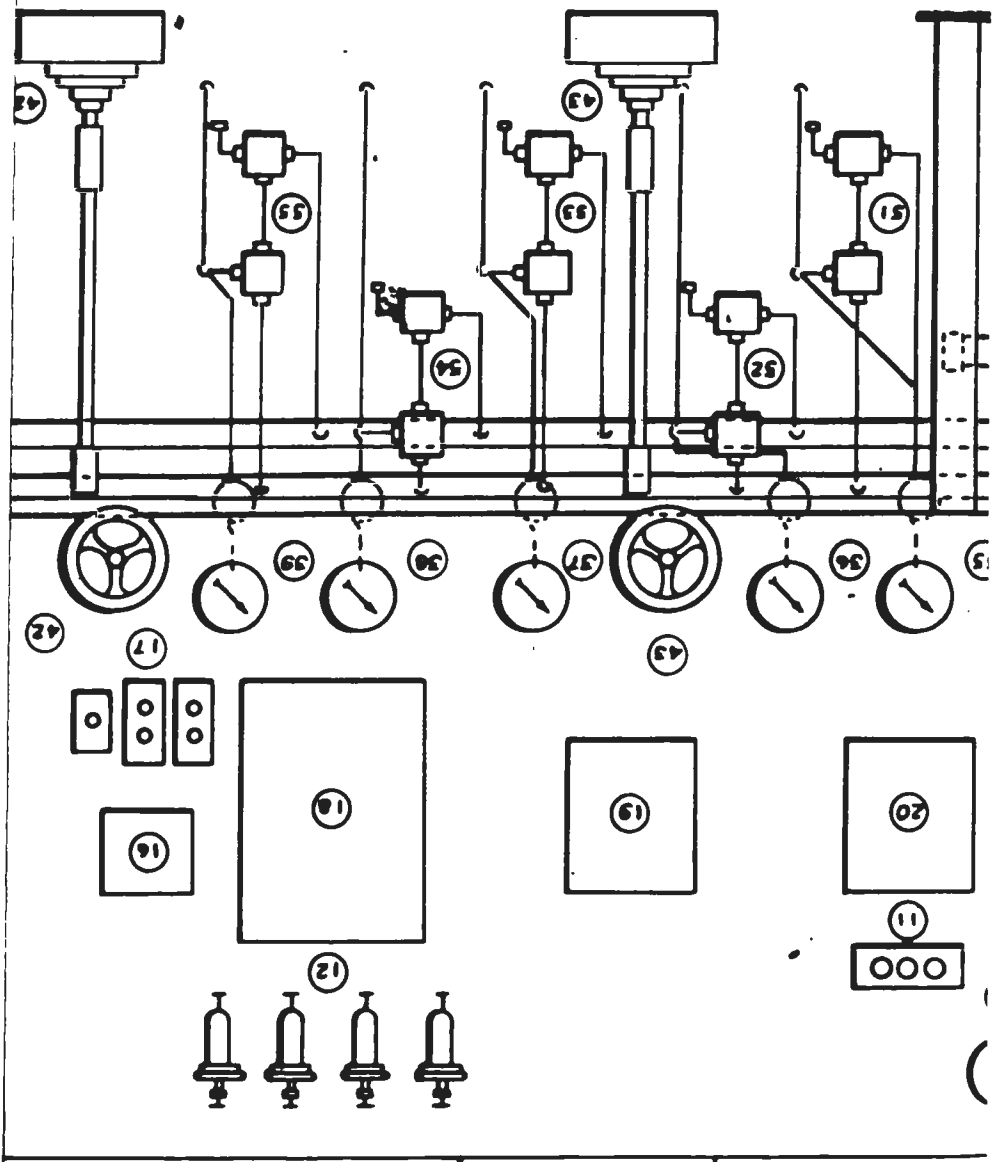

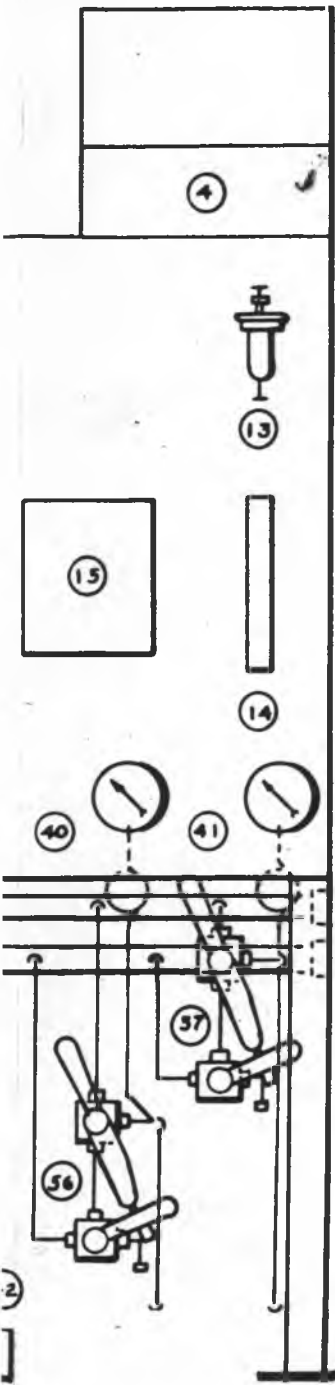

1. WATER TO CELL SPRAYS
  - 2-3-4 LOUDSPEAKERS
  - 5 BUBBLERS FOR CATCH TANK LEVEL GAGE
  - 6 BUBBLER FOR CELL PRESSURE GAGE
  - 7 STEAM PRESSURE
  - 8 AIR PRESSURE
  - 9 BUBBLERS FOR PRECIPITATOR LEVEL GAGE
  - 10 HF PRESSURE, CELL 2 ONLY
  - 11 SIGNAL LIGHTS
  - 12 BUBBLERS FOR NEUTRALIZER LEVEL GAGE
  - 13 BUBBLER FOR CENTRIFUGE LEVEL GAGE
  - 14 CENTRIFUGE LEVEL GAGE
  - 15 SAFETY METER
  - 16 CENTRIFUGE TACHOMETER
  - 17 CENTRIFUGE CONTROLS
  - 18 NEUTRALIZER LEVEL GAGE
  - 19 SAFETY METER
  - 20 RECORDING THERMOMETER - 4 PEN
  - 21 CATCH TANK MOTOR CONTROL
  - 22 PHONEJACK
  - 23 PRECIPITATOR LEVEL GAGE
  - 24 RECORDING THERMOMETER - 1 PEN
  - 25 PRECIPITATOR MOTOR CONTROL
  - 26 CELL PRESSURE GAGE
  - 27 CATCH TANK LEVEL GAGE
  - 28-41 INC. PRESS. AND VAC. ALARM GAGES ON SYPHON LINES
  - 42 CENTRIFUGE FLOW CONTROL
  - 43 " SKIMMER "
  - 44 PRECIPITATOR SPARGER - CONTROL VALVES \*
  - 45 " SYPHON 1 " "
  - 46 " " 2 " "
  - 47 CENTRIFUGE CATCH TANK SPARGER - CONTROL VALVES
  - 48 " " " SYPHON 1 " "
  - 49 " " " " 2 " "
  - 50 HF SPARGER CONTROL VALVES
  - 51 NEUTRALIZER SPARGER - CONTROL VALVES
  - 52 SPARE " "
  - 53 NEUTRALIZER SYPHON 1 " "
  - 54 " " 2 " "
  - 55 SPARE " "
  - 56 PRECIPITATOR " 1 " " \*\*
  - 57 " " 2 " "
  - 58 WATER TO NEUTRALIZER JACKET
  - 59 " " PRECIPITATOR "
- \* THREE-WAY AIR AND STEAM VALVES  
 \*\* LINKAGES ARE USED, ON ALL CONTROL VALVES

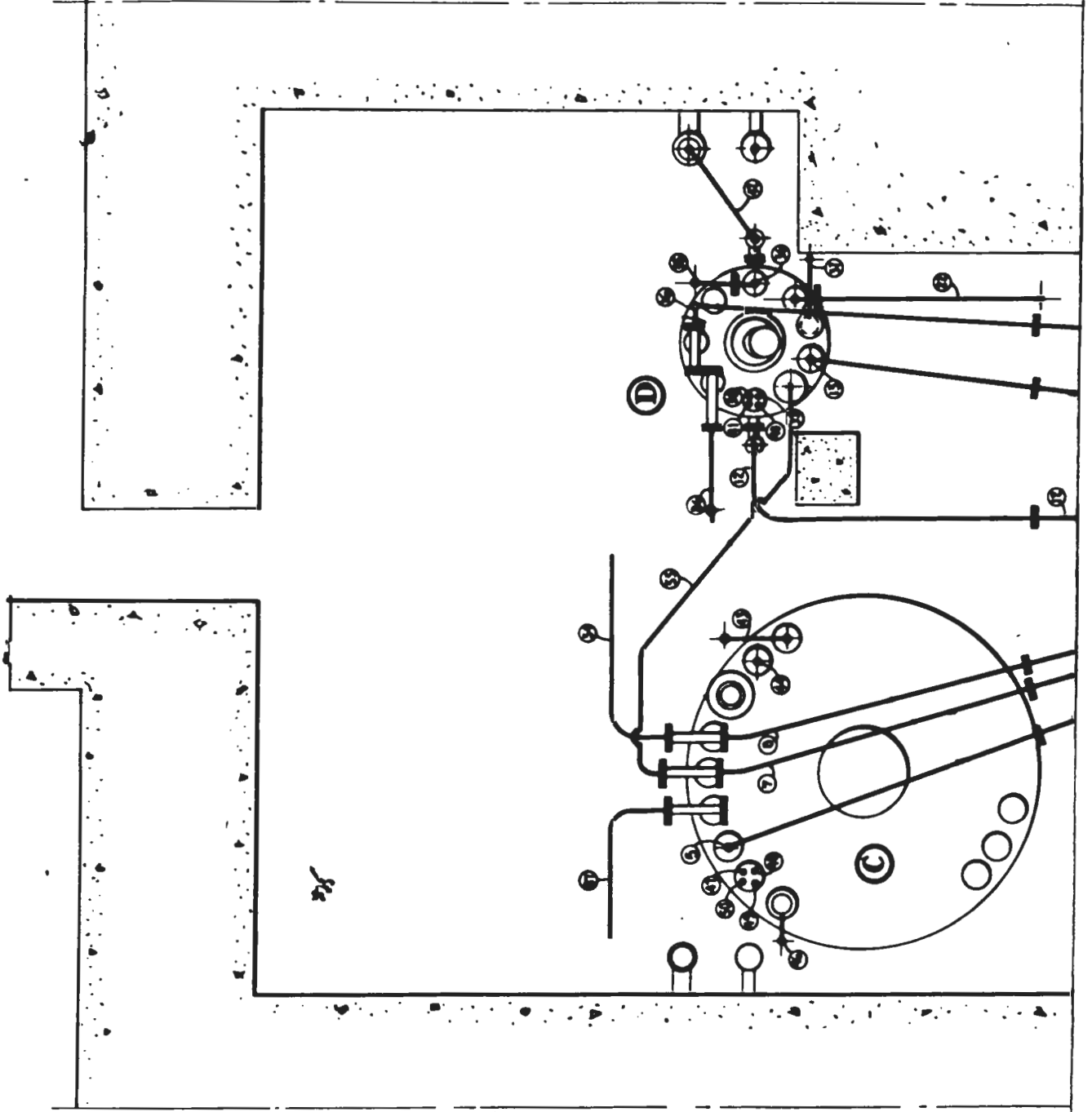

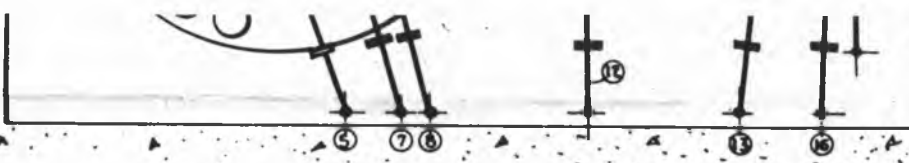

PLAN OF LOWER VESSELS

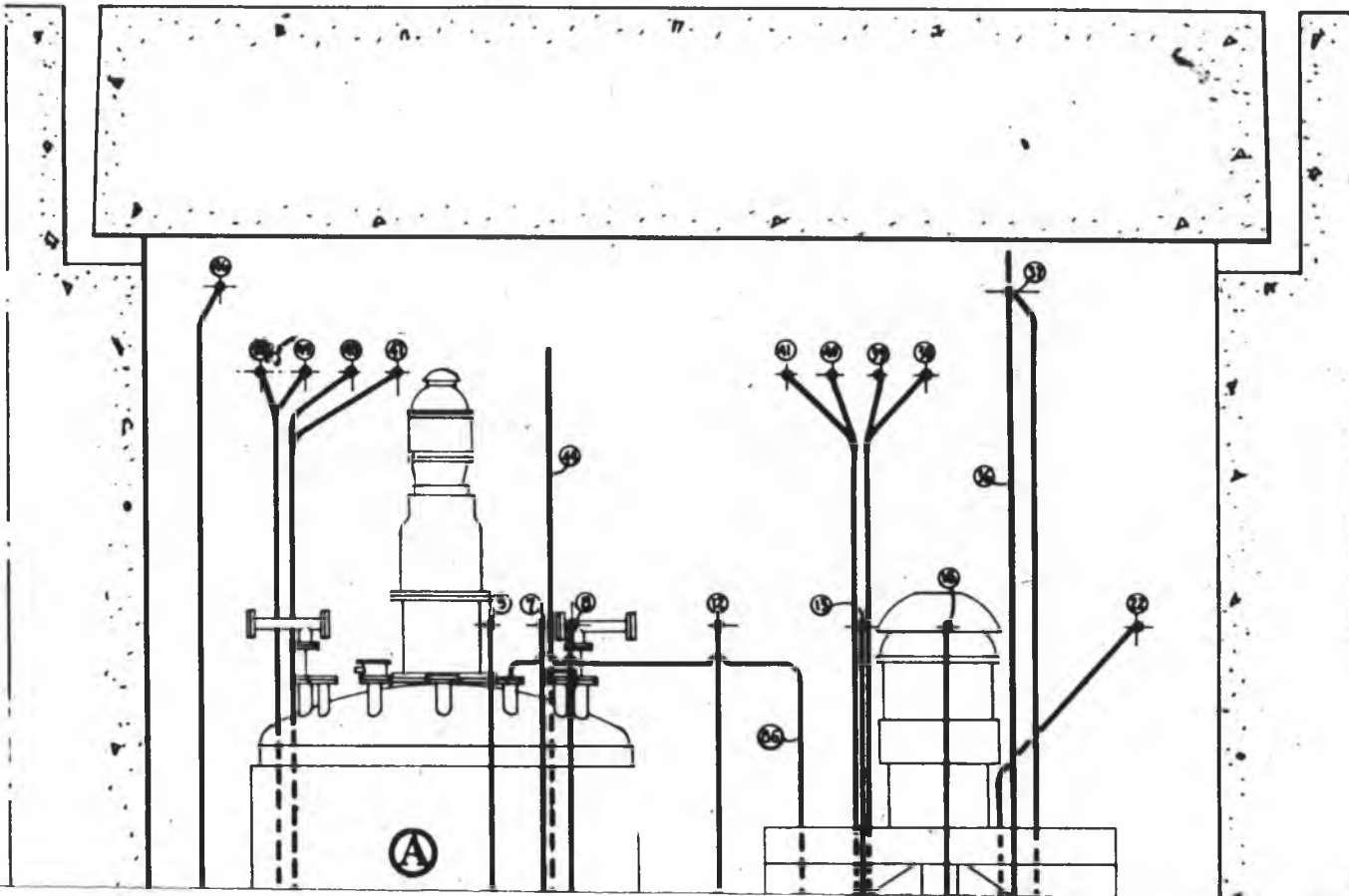

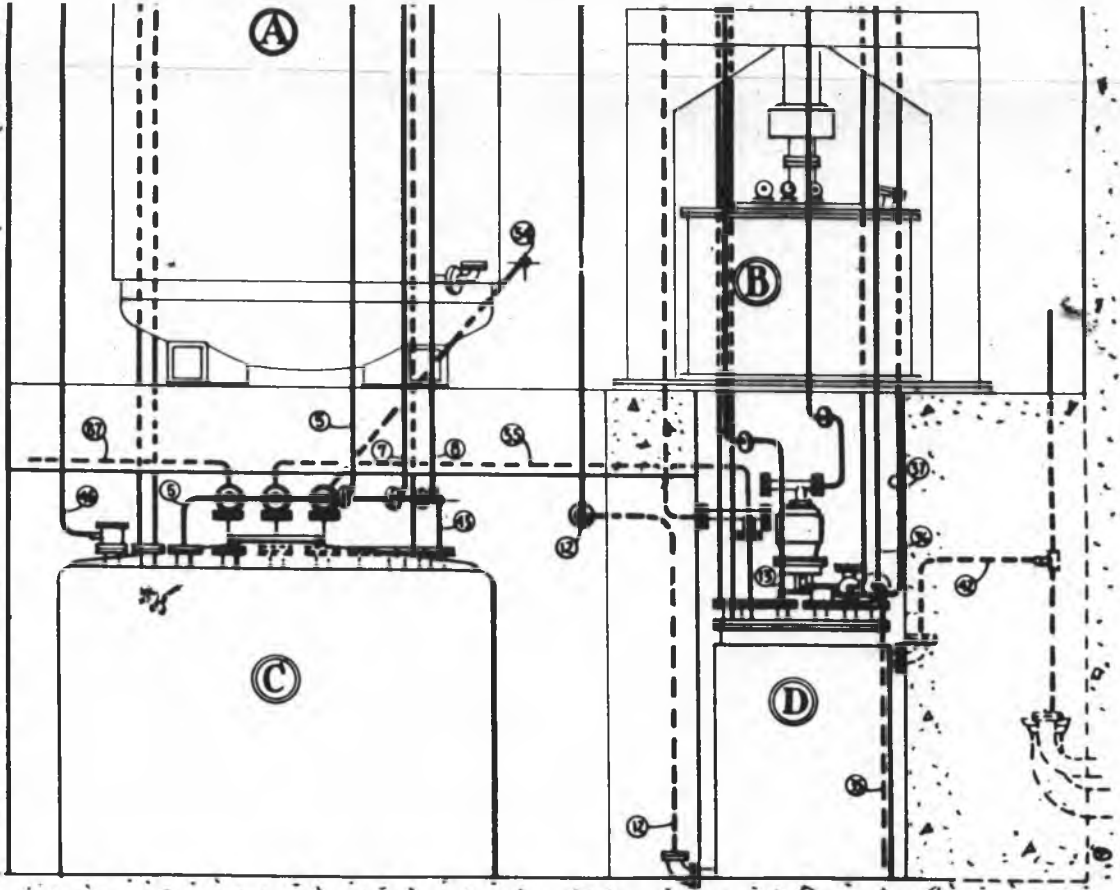

FRONT ELEVATION

- LEGEND -

- (A) - PRECIPITATOR
- (B) - CENTRIFUGE
- (C) - CENTRIFUGE CATCH TANK
- (D) - NEUTRALIZER
- (1) - CENTRIFUGE CATCH TANK SPARGER, AIR AND STEAM
- (7) - CENTRIFUGE " " DELIVERY SYPHON 1, AIR AND STEAM
- (8) - CENTRIFUGE " " " 2, " " "
- (13) - WATER TO NEUTRALIZER JACKET
- (14) - NEUTRALIZER SPARGER, AIR AND STEAM
- (15) - NEUTRALIZER DELIVERY SYPHON 1, AIR AND STEAM
- (16) - NEUTRALIZER " " 2, " " "
- (22) - SCALE TANK TO NEUTRALIZER
- (25) - NEUTRALIZER OVERFLOW
- (32) - NEUTRALIZER SAMPLER
- (37) - NEUTRALIZER THERMOMETER
- (38, 39, 41) - LIQUID LEVEL GAGE LEADS - NEUTRALIZER
- (42) - NEUTRALIZER JACKET OVERFLOW
- (43) - CATCH TANK VENT
- (44) - CATCH " SAMPLER
- (45) - CATCH " THERMOMETER
- (47, 48, 49, 50) - CATCH TANK LIQUID LEVEL GAGE LEADS
- (51) - NEUTRALIZER TO PRECIPITATOR
- (52) - CATCH TANK TO NEUTRALIZER, CELL NO 5
- (53) - CATCH TANK TO PRECIPITATOR, CELL NO 3
- (55) - " " " NEUTRALIZER

EQUIPMENT OF CELL NO. 2  
LOWER VESSELS

15 47

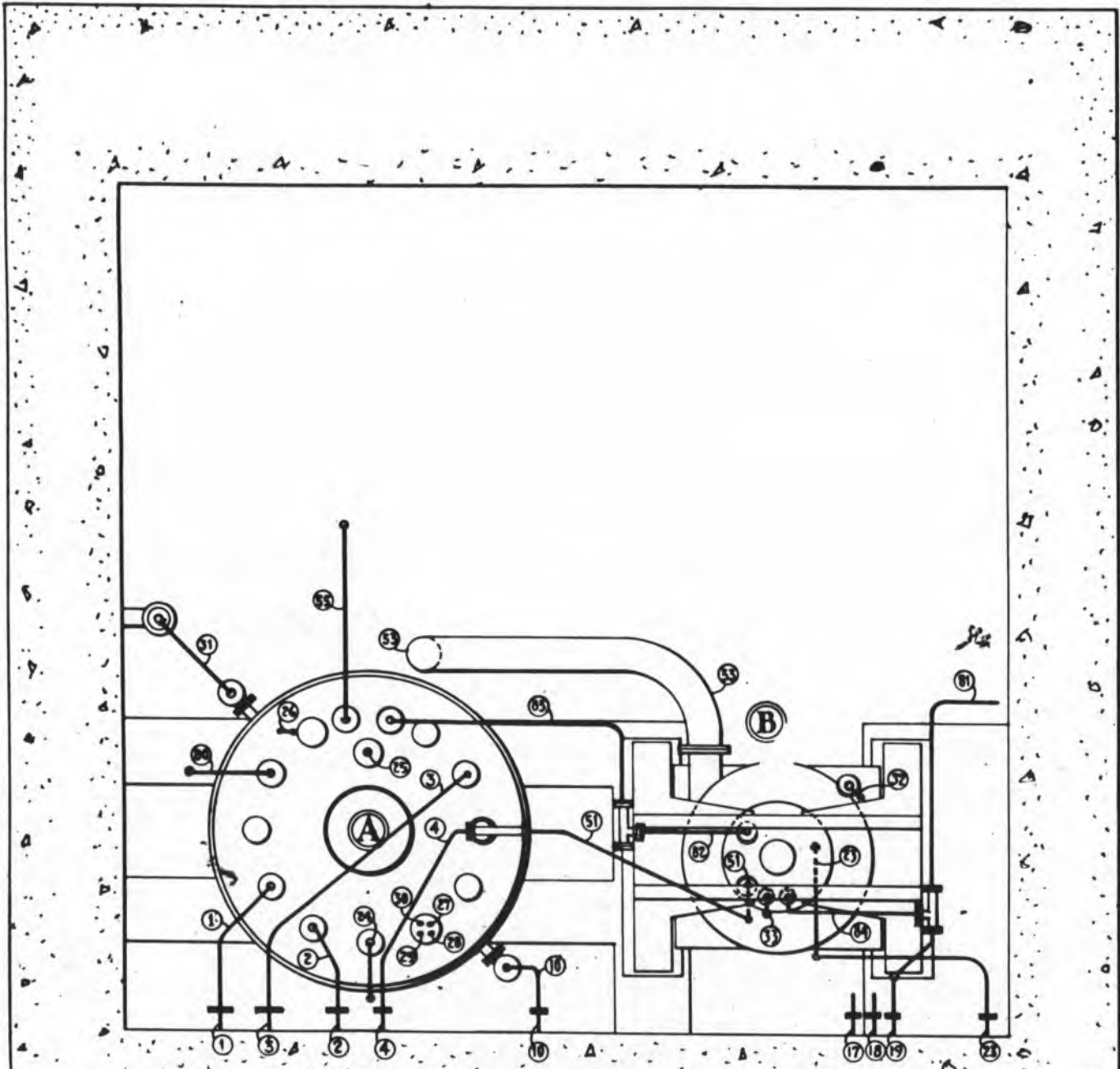

PLAN OF UPPER VESSELS

# PLAN OF UPPER VESSELS

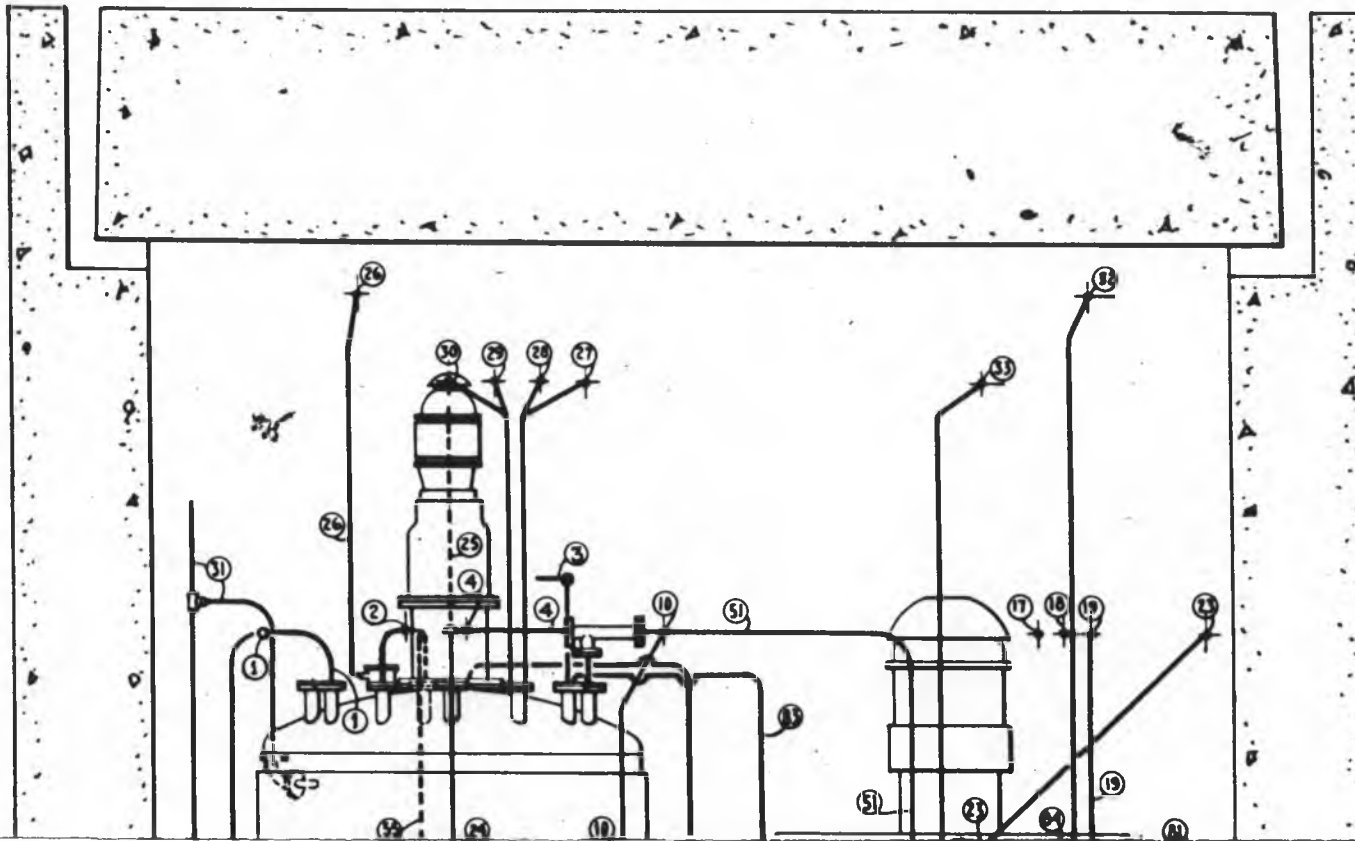



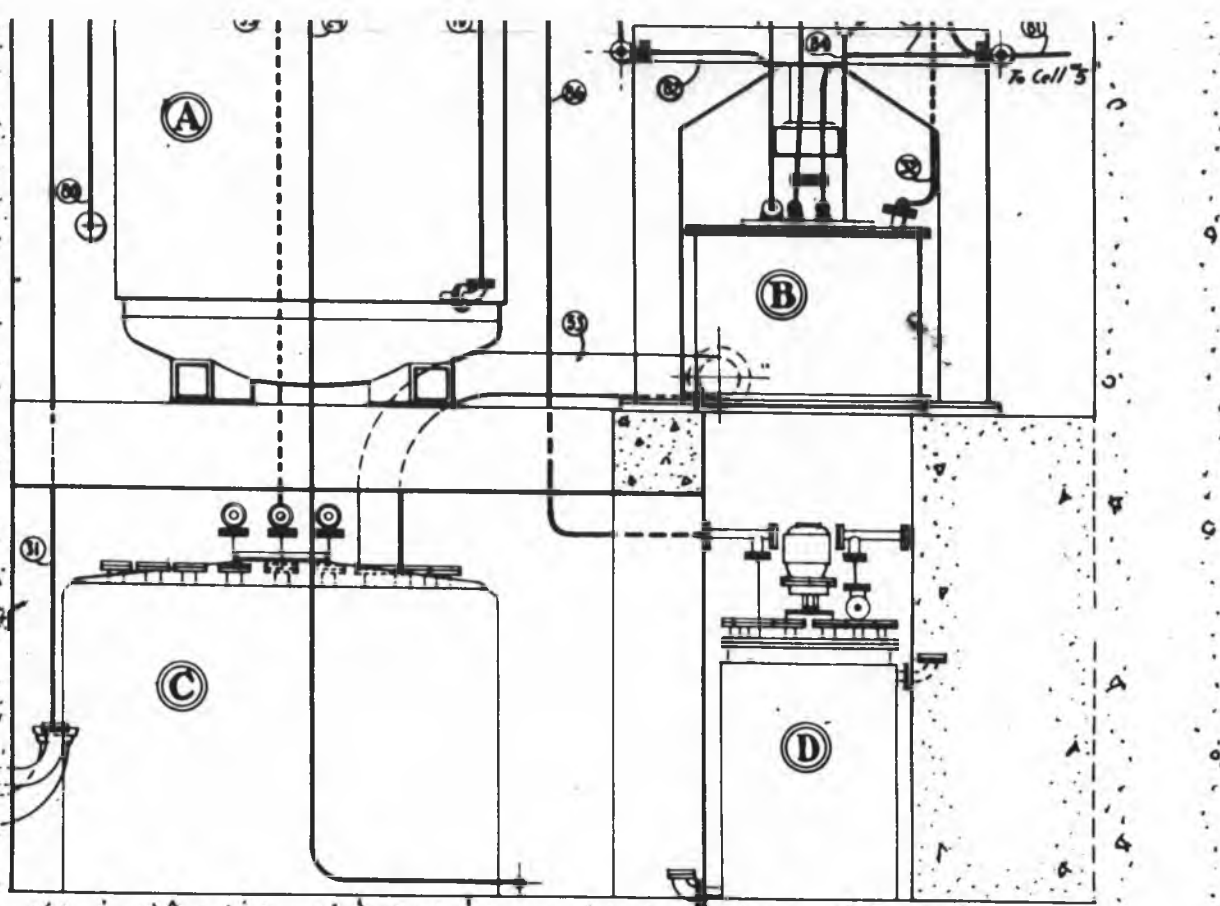

FRONT ELEVATION

**EQUIPMENT OF CELL NO. 2  
UPPER VESSELS**

**- LEGEND -**

- |   |   |
|---|---|
| <ul style="list-style-type: none"> <li>Ⓐ - PRECIPITATOR</li> <li>Ⓑ - CENTRIFUGE</li> <li>Ⓒ - CENTRIFUGE CATCH TANK</li> <li>Ⓓ - NEUTRALIZER</li> <li>① - PRECIPITATOR SCALE TANK TO PRECIPITATOR</li> <li>② - TO SPARGER - AIR AND STEAM</li> <li>③ - CHARGE FUNNEL TO PRECIPITATOR</li> <li>④ - TO DELIVERY SYNPHON, CENTRIFUGE, AIR &amp; STEAM</li> <li>⑩ - WATER TO PRECIPITATOR JACKET</li> <li>⑪ - TO EMERGENCY PRECIPITATOR SYNPHON, AIR AND STEAM</li> <li>⑫ - TO DELIVERY</li> <li>⑬ - CENTRIFUGE SCALE TANK TO CENTRIFUGE BOWL SPRAYS</li> <li>⑭ - PRECIPITATOR VENT TO CELL</li> </ul> | <ul style="list-style-type: none"> <li>⑮ - PRECIPITATOR SAMPLER</li> <li>⑯ - PRECIPITATOR THERMOMETER</li> <li>⑰ ⑱ ⑲ - PRECIPITATOR LIQUID LEVEL GAGE BUBBLERS</li> <li>⑳ - PRECIPITATOR JACKET OVERFLOW</li> <li>㉑ - CENTRIFUGE THERMOMETER</li> <li>㉒ - CENTRIFUGE LEVEL MONOMETER</li> <li>㉓ - PRECIPITATOR TO CENTRIFUGE</li> <li>㉔ - CENTRIFUGE TO CENTRIFUGE CATCH TANK</li> <li>㉕ - CENTRIFUGE CATCH TANK TO NEUTRALIZER, CELL 5</li> <li>㉖ - TO PRECIPITATOR FROM CELL NR 1</li> <li>㉗ ㉘ - CENTRIFUGE TO NEUTRALIZER, CELL NO. 5</li> <li>㉙ ㉚ - PRECIPITATOR</li> <li>㉛ - NEUTRALIZER TO</li> </ul> |
|---|---|

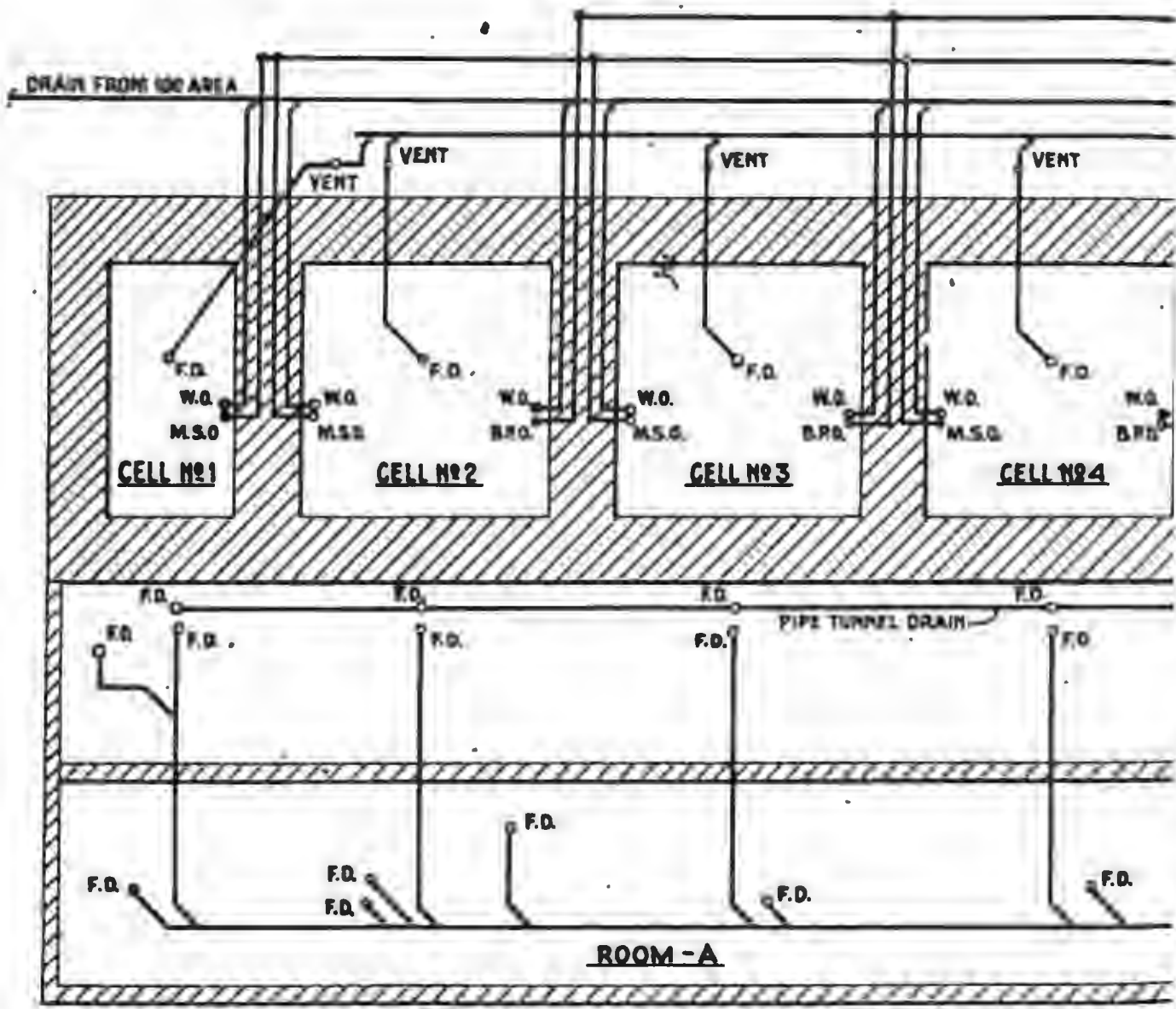

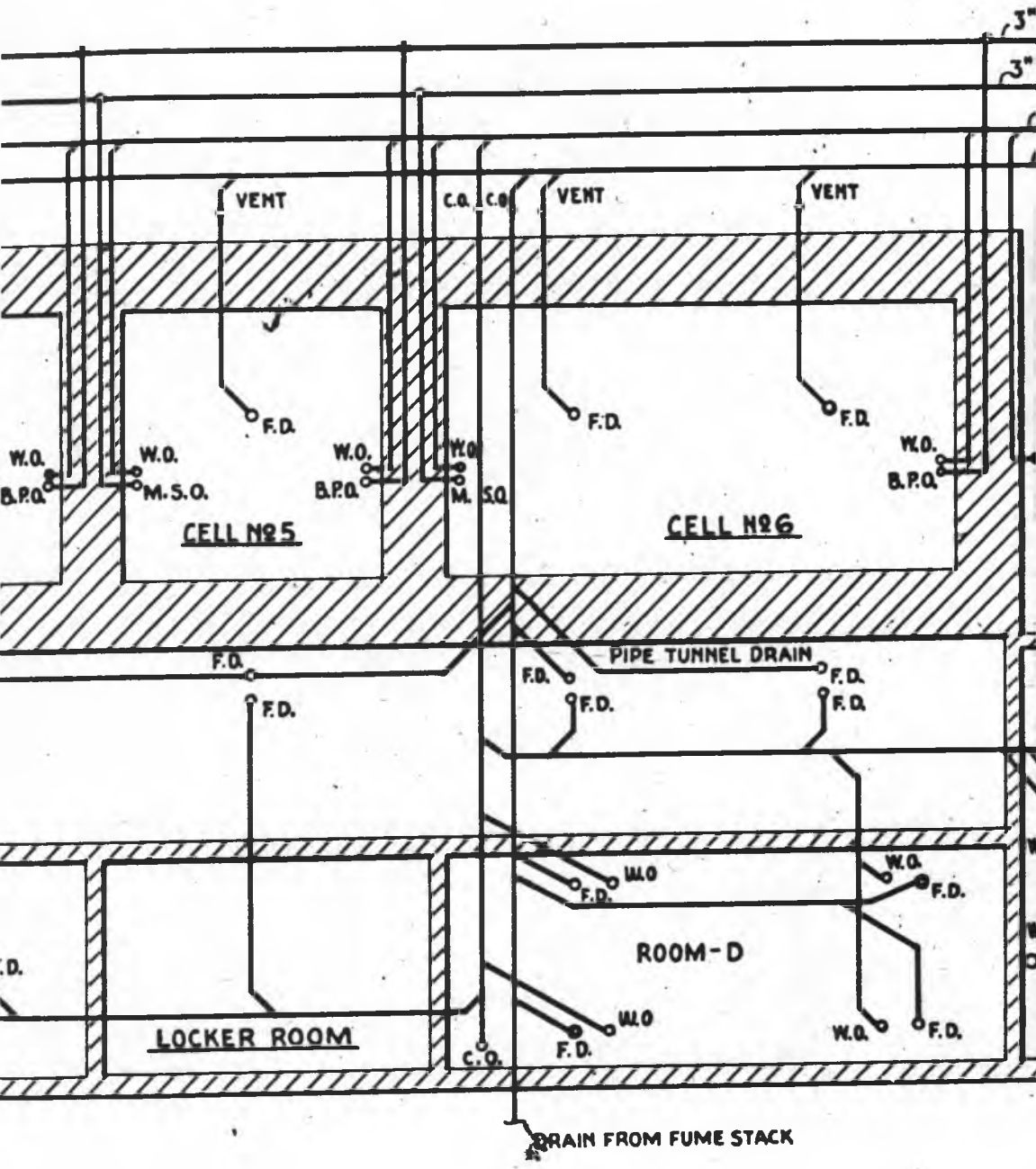

=====

3" S.S. BY-PRODUCT WASTE TO BY-PRODUCT WASTE STORAGE TANKS 206-(121-122)

3" S.S. METAL SOLUTION WASTE TO LIQUID WASH STORAGE TANKS 206 (111-116 MO)

15" T.C. COOLING WATER TO STORAGE PONDS

6" C.W. FLOOR DRAINAGE TO TEMPORARY STORAGE TANKS 206-(102-103)

MANHOLE

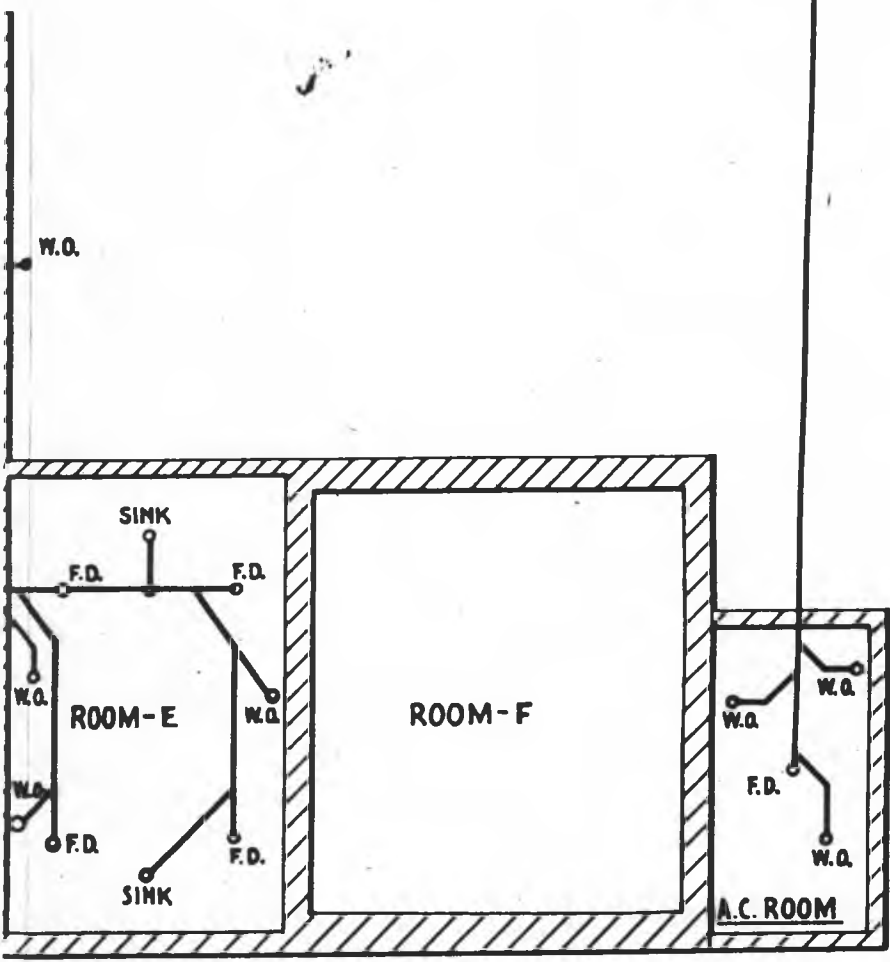

**DRAINAGE AND WASTE SYSTEM**  
**FOR BUILDING 205**

**- LEGEND -**

- F.D. - FLOOR DRAIN
- C.O. - CLEAN OUT (TO GRADE)
- W.O. - WATER OUTLET
- M.S.O - METAL SOLUTION WASTE OUTLET
- B.P.Q. - BY-PRODUCT WASTE OUTLET



# WASTE DISPOSAL SYSTEM

1. BY-PRODUCTS
2. METAL SOLUTION
3. COOLING WATER
4. QUESTIONABLE WASTES, WASHOUTS, ETC.

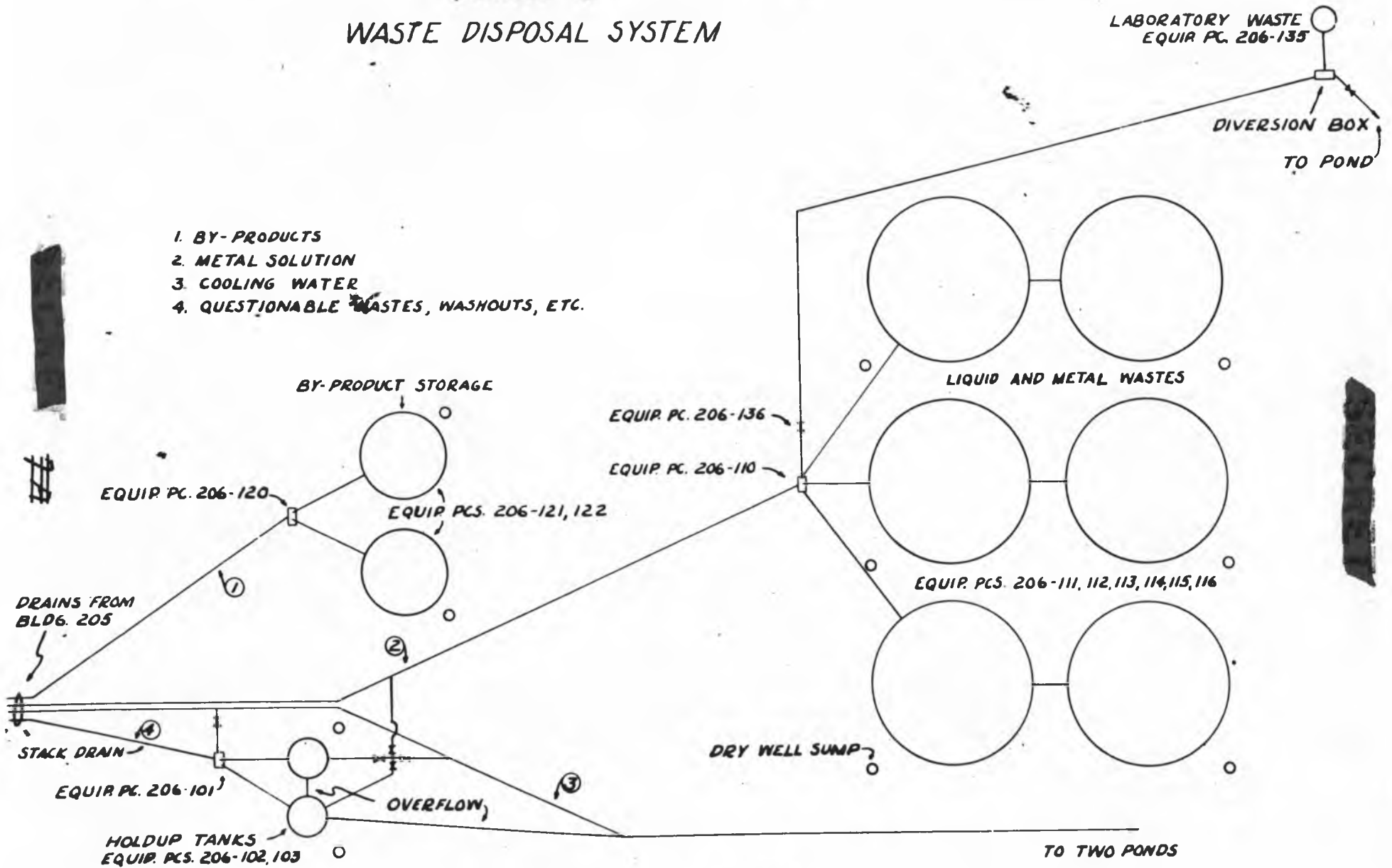

**MAIN METAL AND LIQUID WASTES STORAGE  
TYPICAL SECTION**

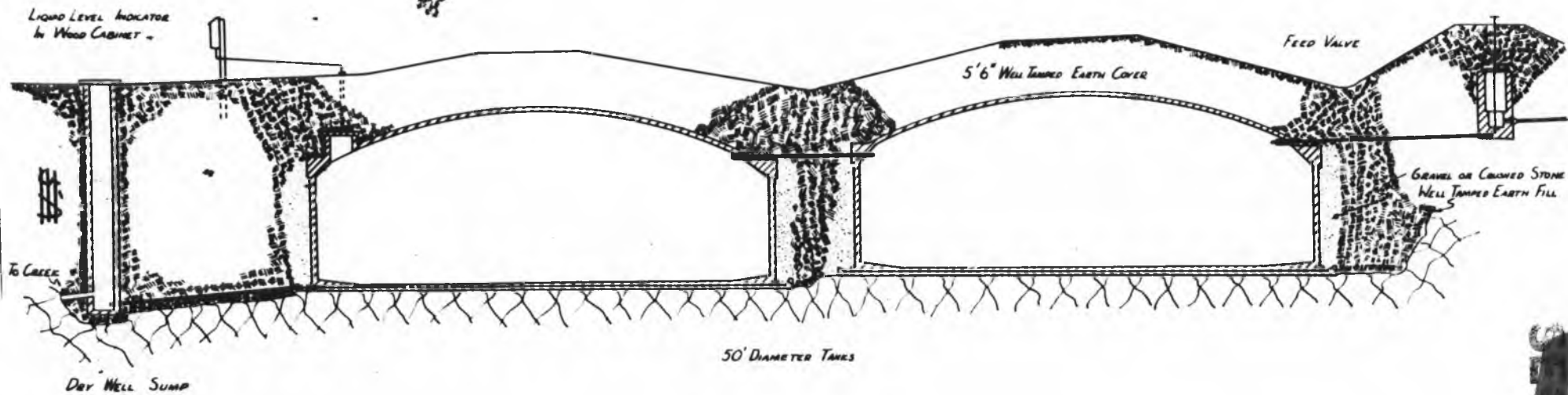

APPENDIX A 23

AERIAL VIEW OF CLINTON LABORATORIES

Extension  
GO TO SEE YOU  
DES AN APPOINTME

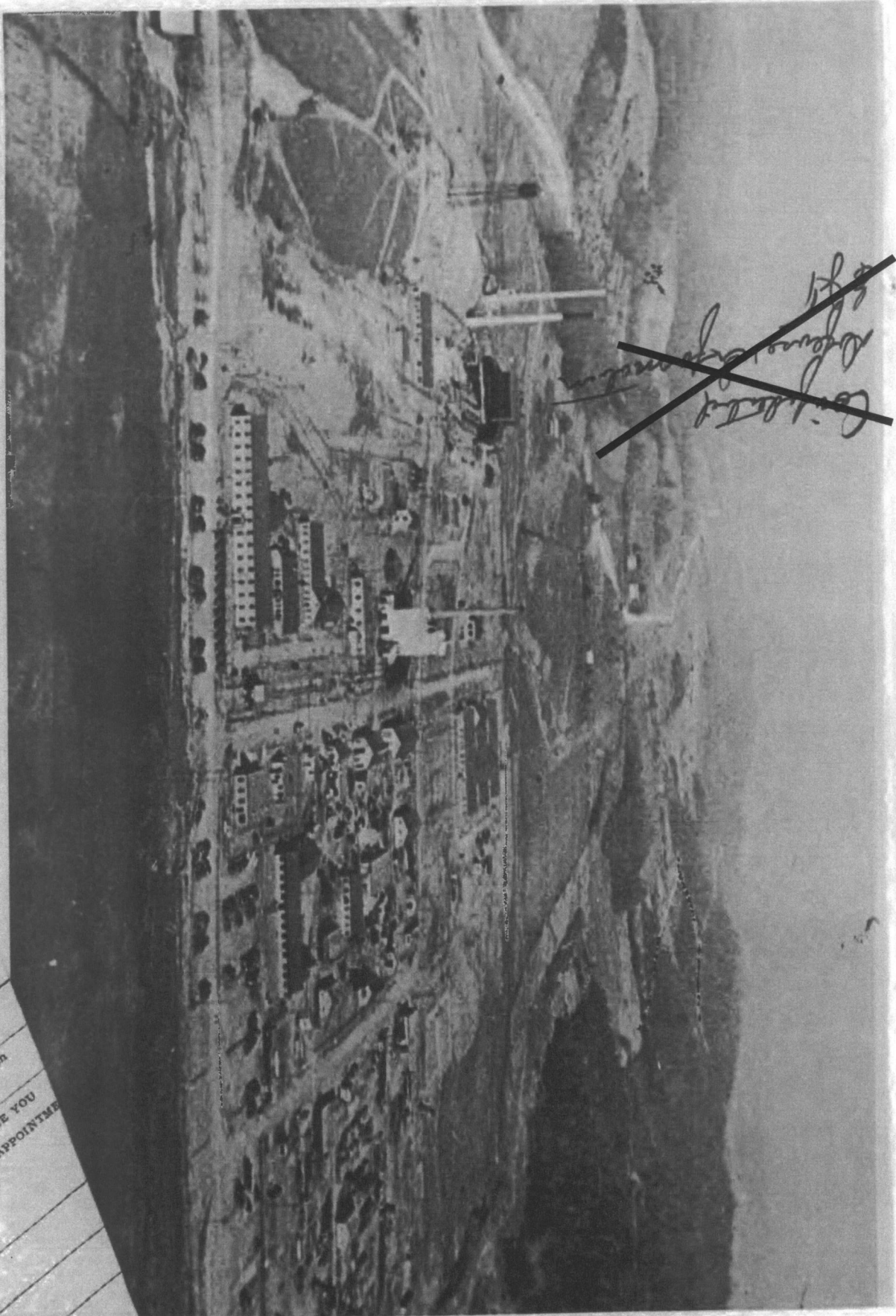

~~Co. 1st Lt. J. J. [unclear]  
Admiral [unclear]  
[unclear]~~



~~SECRET~~

APPENDIX A 24

FILE BUILDING UNDER CONSTRUCTION (6/4/43)

The foreground shows the water canal from the File Building to the Separation Building under construction. This canal was to provide a means of transferring irradiated uranium slugs, under water, to the Separation Building.

~~SECRET~~



APPENDIX A 25

PILE BUILDING UNDER CONSTRUCTION (6/27/43)

The right foreground shows the File Building under construction. The building in the background houses a special shop for machining the graphite used in the File.



APPENDIX A 26

FILE BUILDING UNDER CONSTRUCTION (7/14/43)

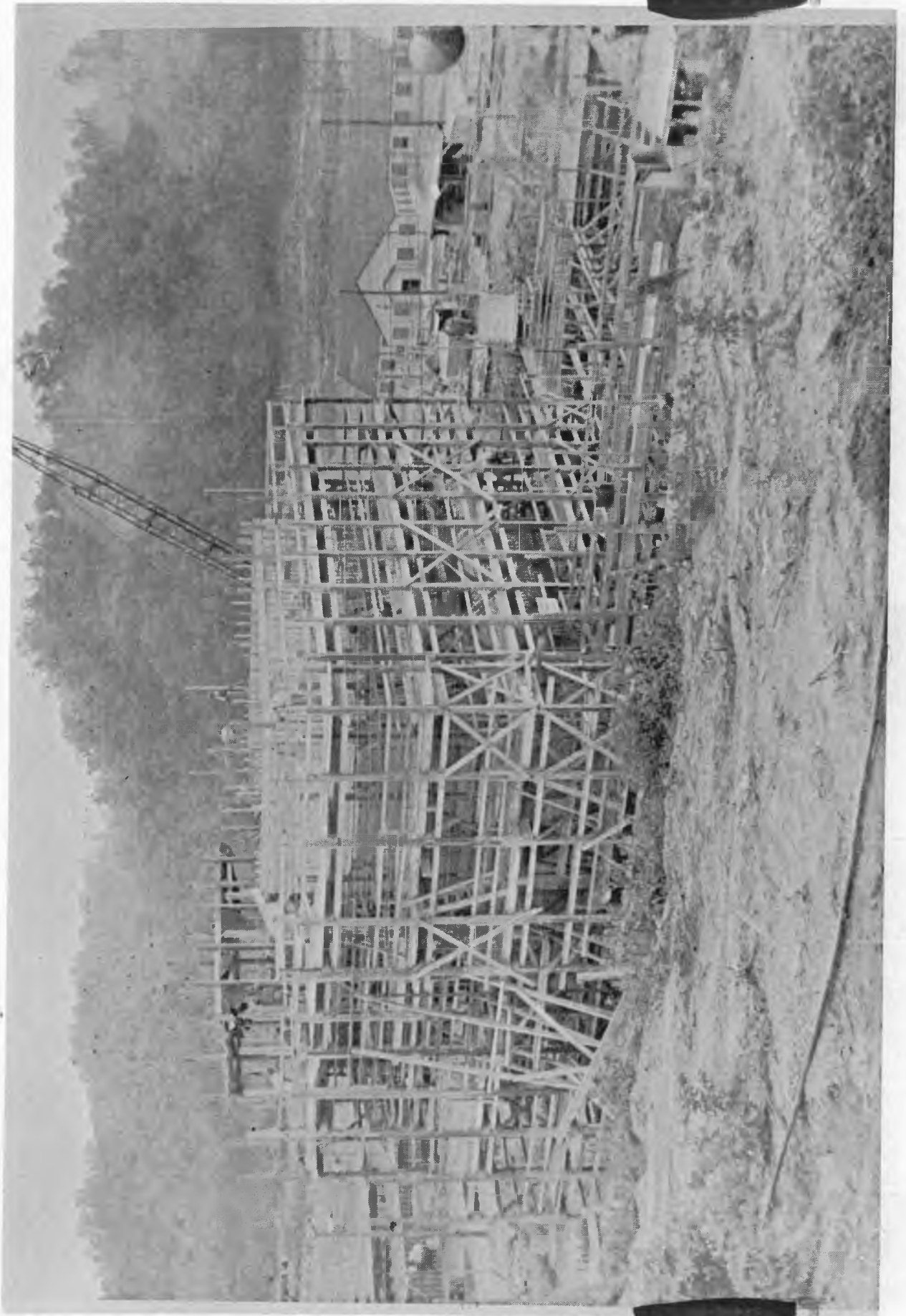

APPENDIX A 27

AERIAL VIEW OF PILE, SEPARATION, AND EXHAUSTER  
BUILDINGS DURING CONSTRUCTION (8/31/43)

~~Confidential~~ ~~Raymond S. Hughes~~  
EJH

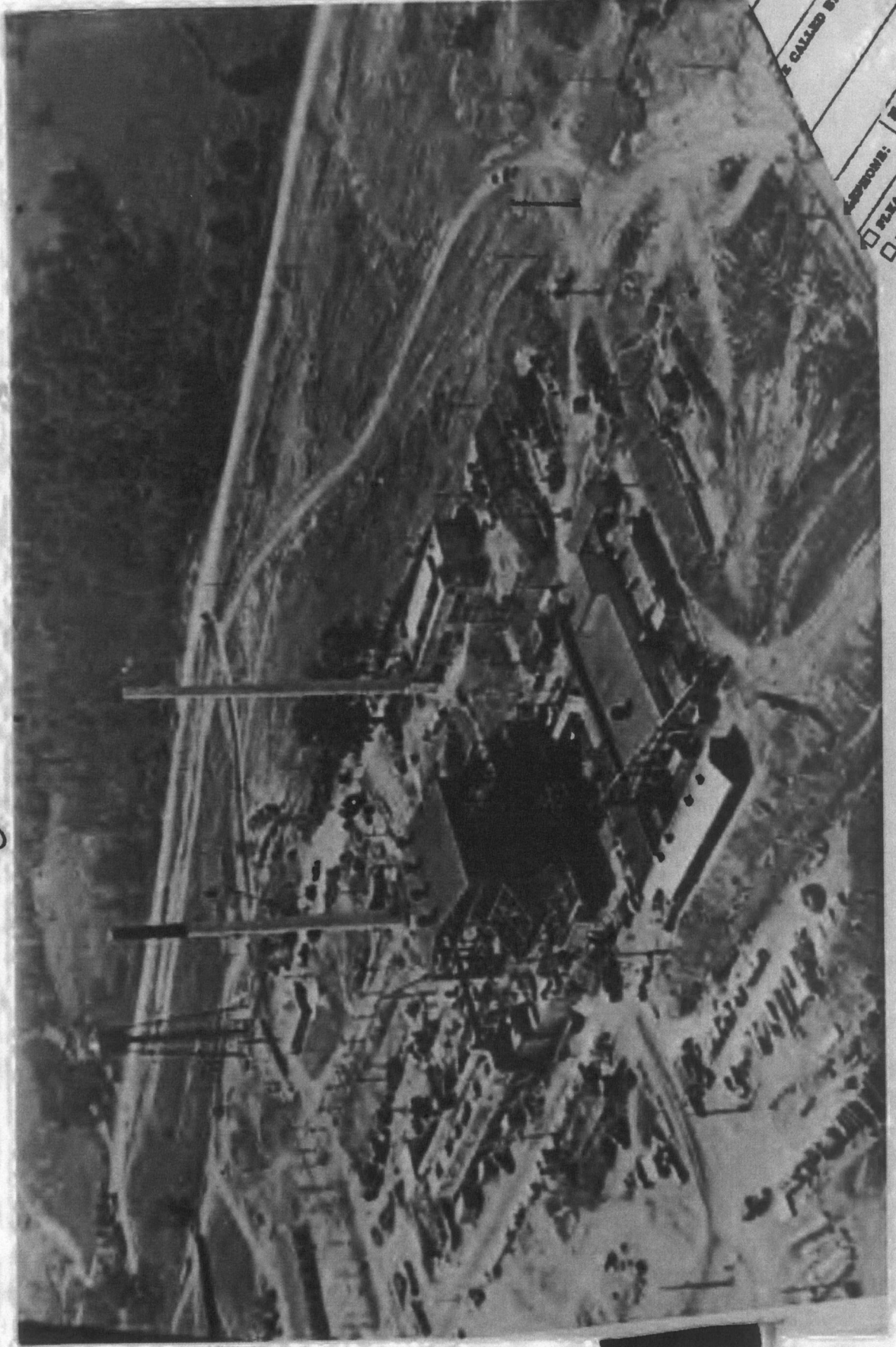

CALLER BY  
ADDRESS:  
PHONE NO.  
CITY  
STATE



APPENDIX A 28

COMPLETED FILE BUILDING - LOOKING NORTH (10/11/43)



~~SECRET~~

APPENDIX A 29

COMPLETED PILE BUILDING - LOOKING SOUTHEAST (10/11/43)

~~SECRET~~



APPENDIX A 30

COMPLETED EXHAUSTER BUILDING - LOOKING EAST (10/11/43)



APPENDIX A 31

EXHAUSTER BUILDING AND EXHAUST STACK - LOOKING

NORTHEAST (11/11/43)

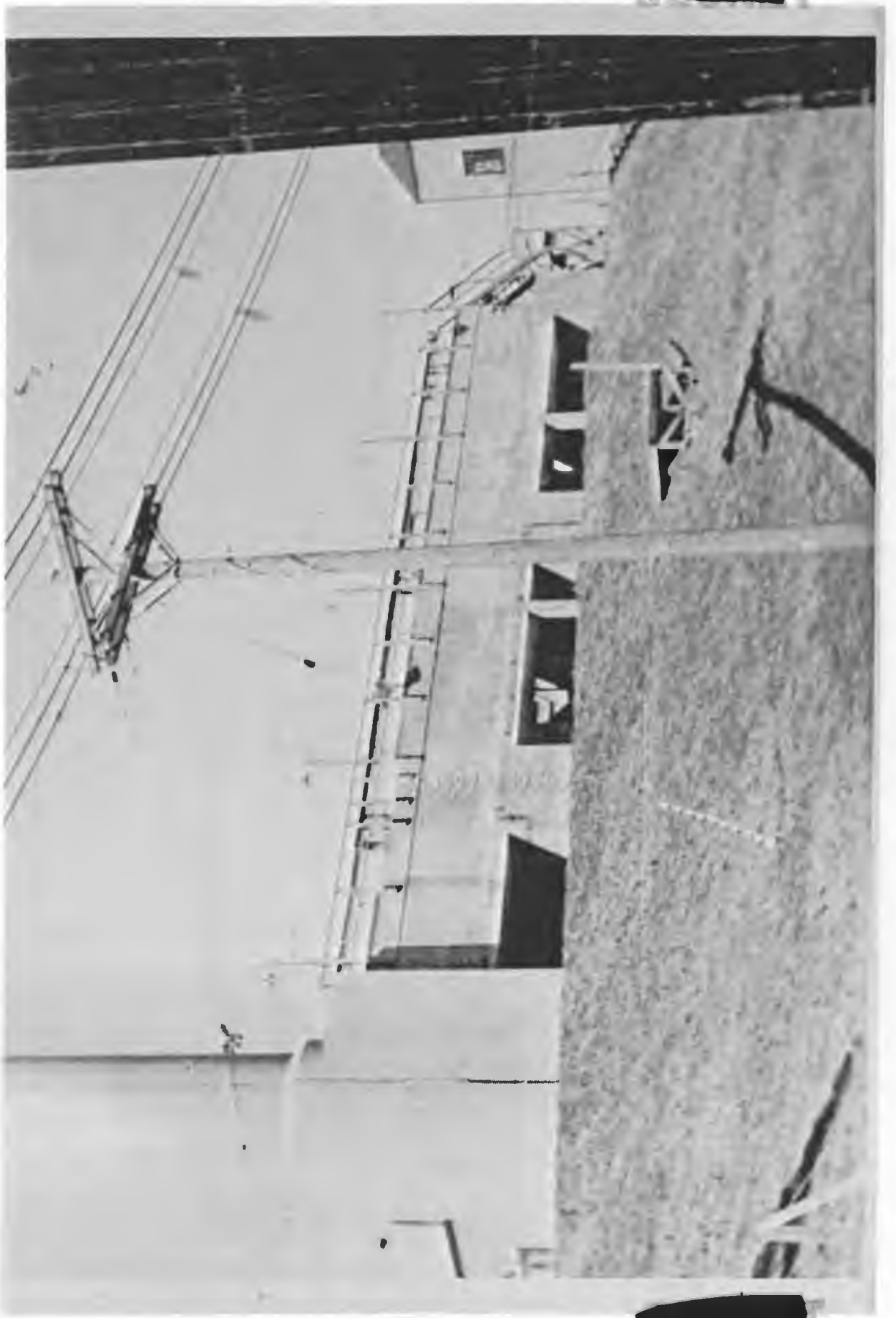



APPENDIX A 32

EAST END OF CLINTON LABORATORIES

AREA (12/20/43)

The right foreground shows the Chemistry Laboratory (706A) Building; the left foreground shows the Waste Storage (206) Area. The Pile (105) Building is located in the center background, to the right of the Separation (205) Building.

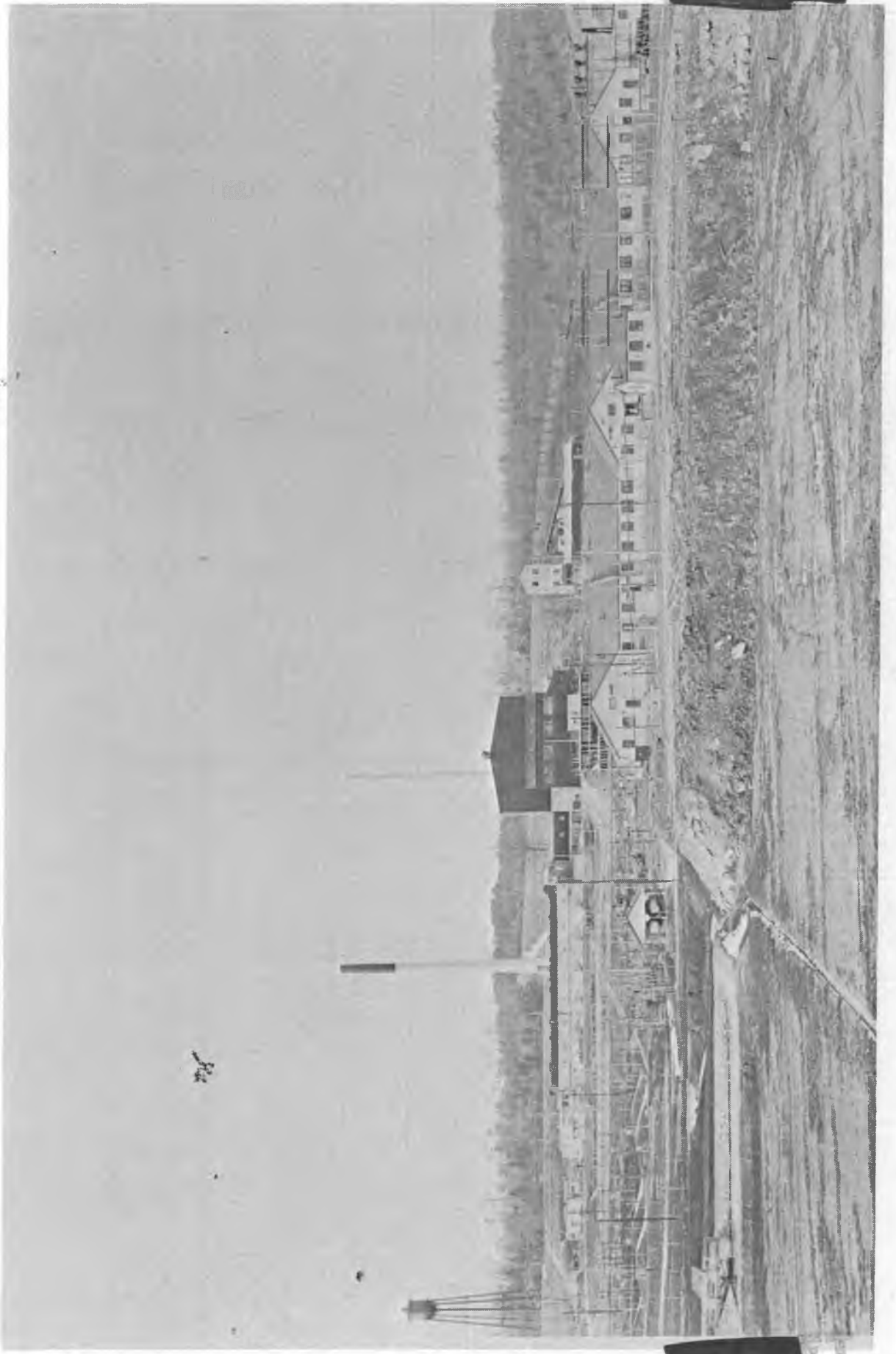

APPENDIX A 33

COMPLETED PILE BUILDING (LEFT) AND SEPARATION  
BUILDING (RIGHT) (12/20/43)



APPENDIX A 34

WASTE STORAGE (206) AREA UNDER CONSTRUCTION (7/14/43)

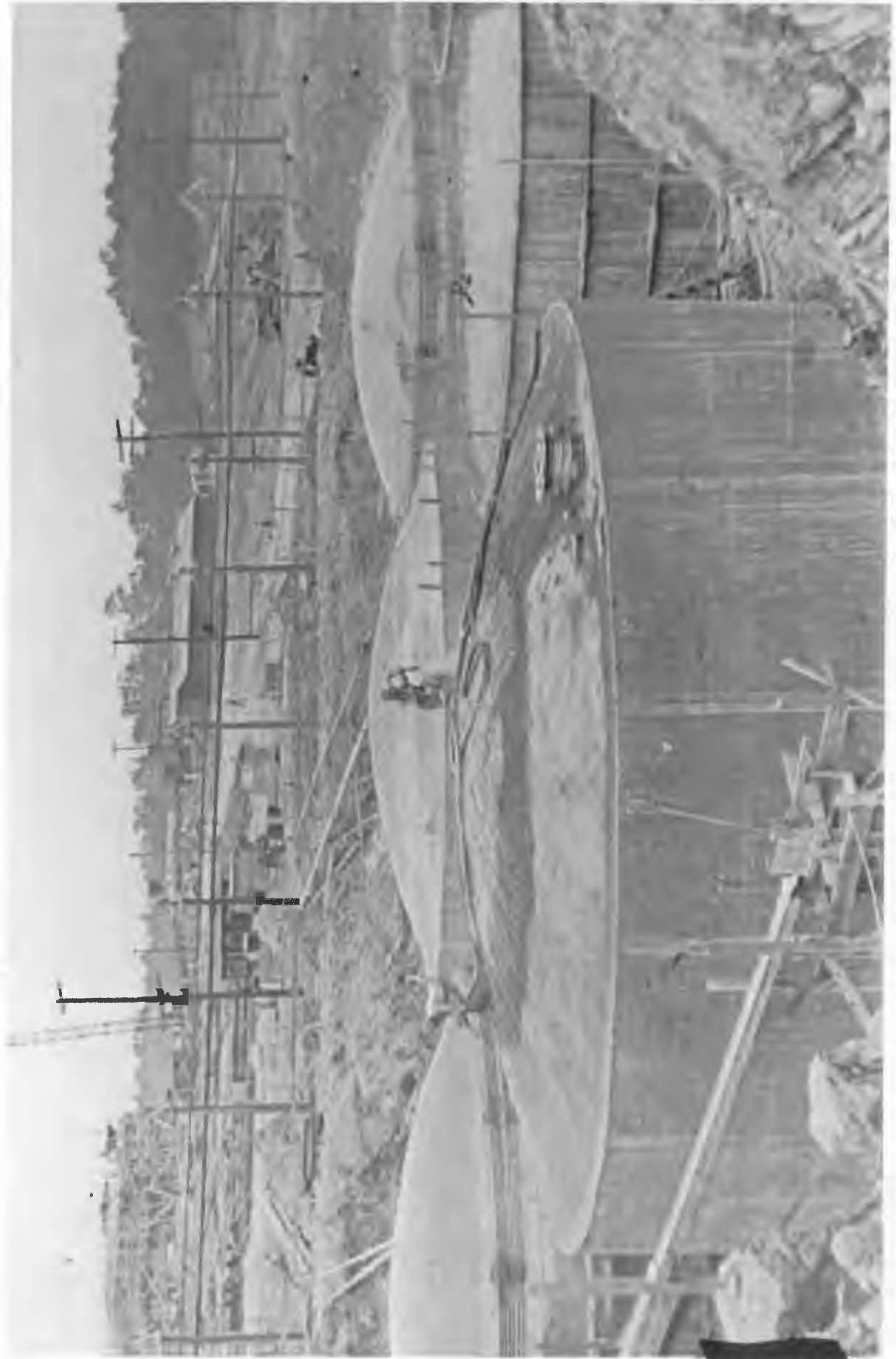

APPENDIX A 35

COMPLETED WASTE STORAGE (206) AREA

Six large storage tanks with a total capacity of about one million gallons are buried six feet below the surface of the ground. These tanks serve as storage space for the processed uranium and the radioactive waste solutions from the Separation (205) Building. Waste solutions are held in this area until harmless, before discharge into White Oak Creek, which flows through the rear of the area.





APPENDIX A 36

WHITE OAK CREEK DAM AND SLUICE GATE (6/27/43)



~~SECRET~~

APPENDIX A 37

COMPLETED WATER TREATMENT (807) BUILDING

~~SECRET~~



APPENDIX A 38

COMPLETED PUMP HOUSE (814) BUILDING (8/10/43)



~~SECRET~~

APPENDIX A 39

STEAM PLANT UNDER CONSTRUCTION (7/14/43)

~~SECRET~~

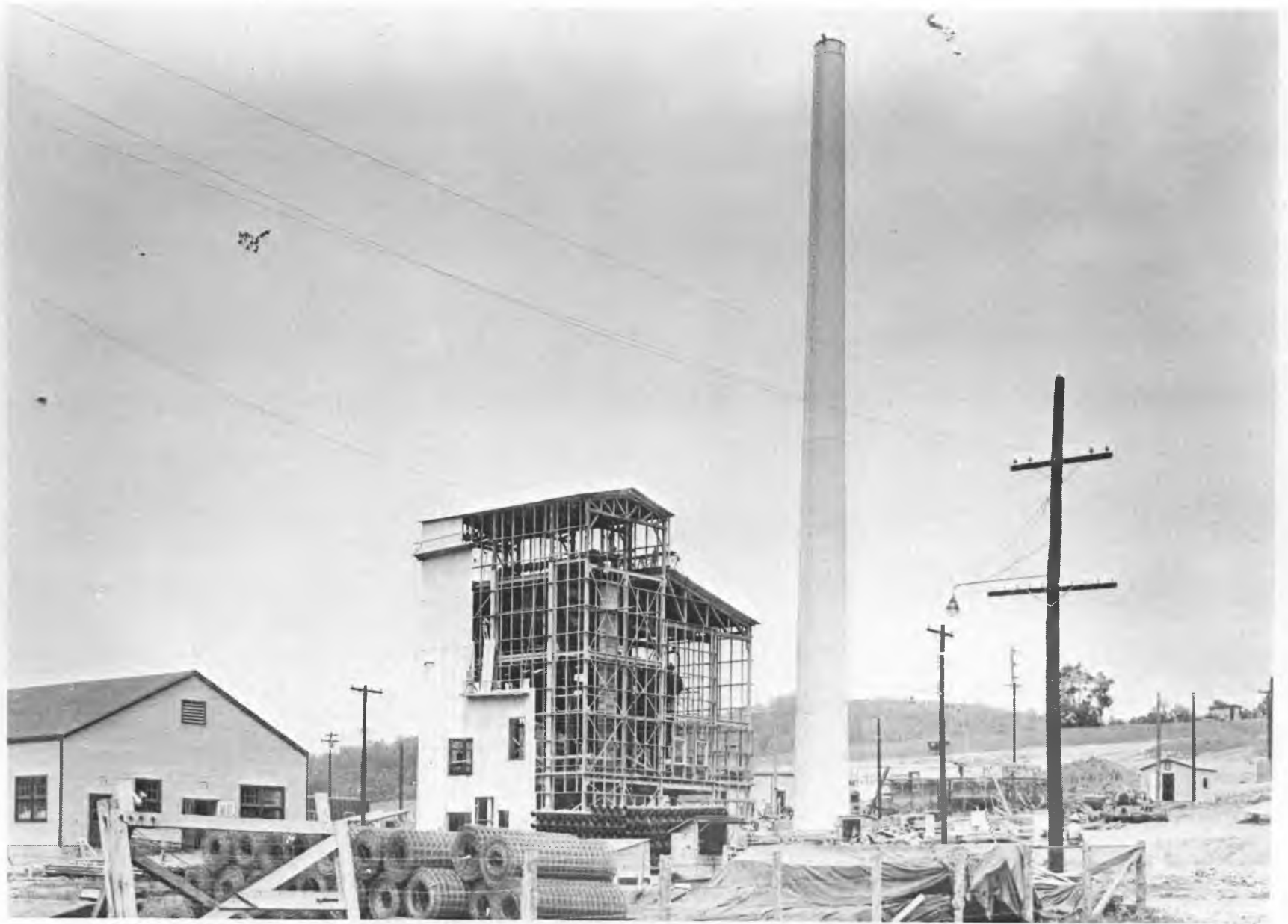



APPENDIX A 40

STEAM PLANT AND RESERVOIR UNDER CONSTRUCTION (10/6/43)

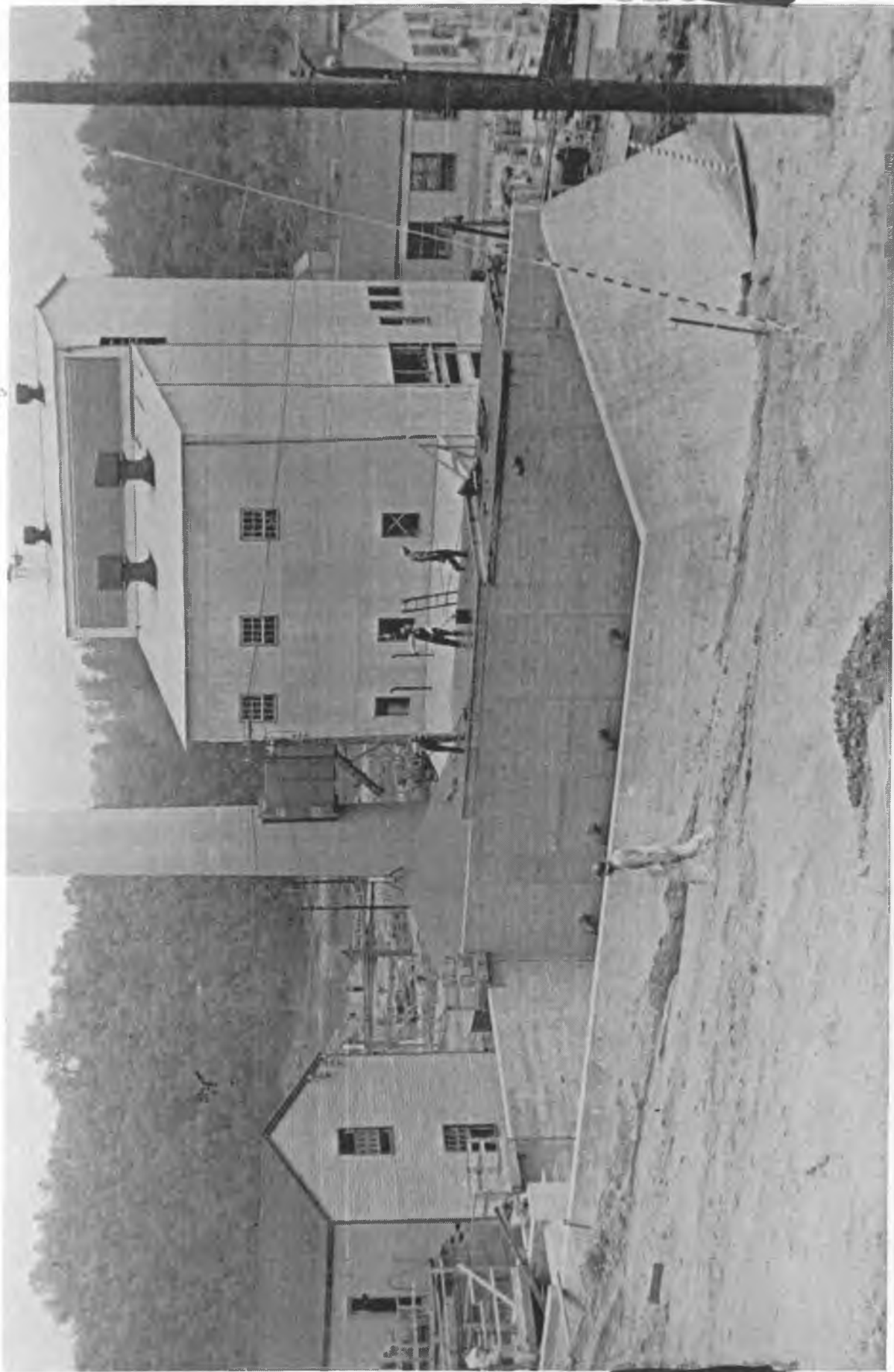



54

APPENDIX A 41

COMPLETED STEAM PLANT - LOOKING NORTHWEST (3/13/44)





APPENDIX A 42

CHEMISTRY LABORATORY (706 A) BUILDING - LOOKING

SOUTHEAST (3/13/44)

The addition at the left end of this building houses the Separation Process Semi-Works. To the right of the building is the "Hot" Laboratory (706 C) Building.

~~Confidential Defense Information~~



YOU WERE VISIT

NOTE: Number of code

PLEASE CALL

WILL CALL AGAIN

RETURN

W.

APPENDIX A 43

"HOT" LABORATORY (706 C) BUILDING - LOOKING

NORTHEAST (3/13/44)

This building houses a special chemical laboratory for the handling of highly radioactive materials.





APPENDIX A 44

PROPANE STORAGE TANKS

These tanks provide storage for the propane gas used as fuel for laboratory burners.



APPENDIX A 45

ORDINARY CHEMICALS STORAGE PLATFORM



APPENDIX A 46

AIR COOLING SYSTEM FAN

This fan, one of the two large fans (70,000 cubic feet per minute capacity) used to cool the Clinton Laboratories Pile, is driven by a 900-horsepower electric motor at a speed of about 3600 revolutions per minute. The two fans operate in parallel to pull air through the Pile.



APPENDIX A 47

PILE CONTROL PANEL

An operator at this panel has complete control of the behavior of the Pile at all times. Through the aid of meters and other recording devices, it is possible for the operator to determine, at any instant, the maximum temperature of the metal in the Pile, inlet and outlet temperatures of the cooling air, operating power level, and temperatures at various points throughout the Pile. Any of the safety and control features can be operated from this point.

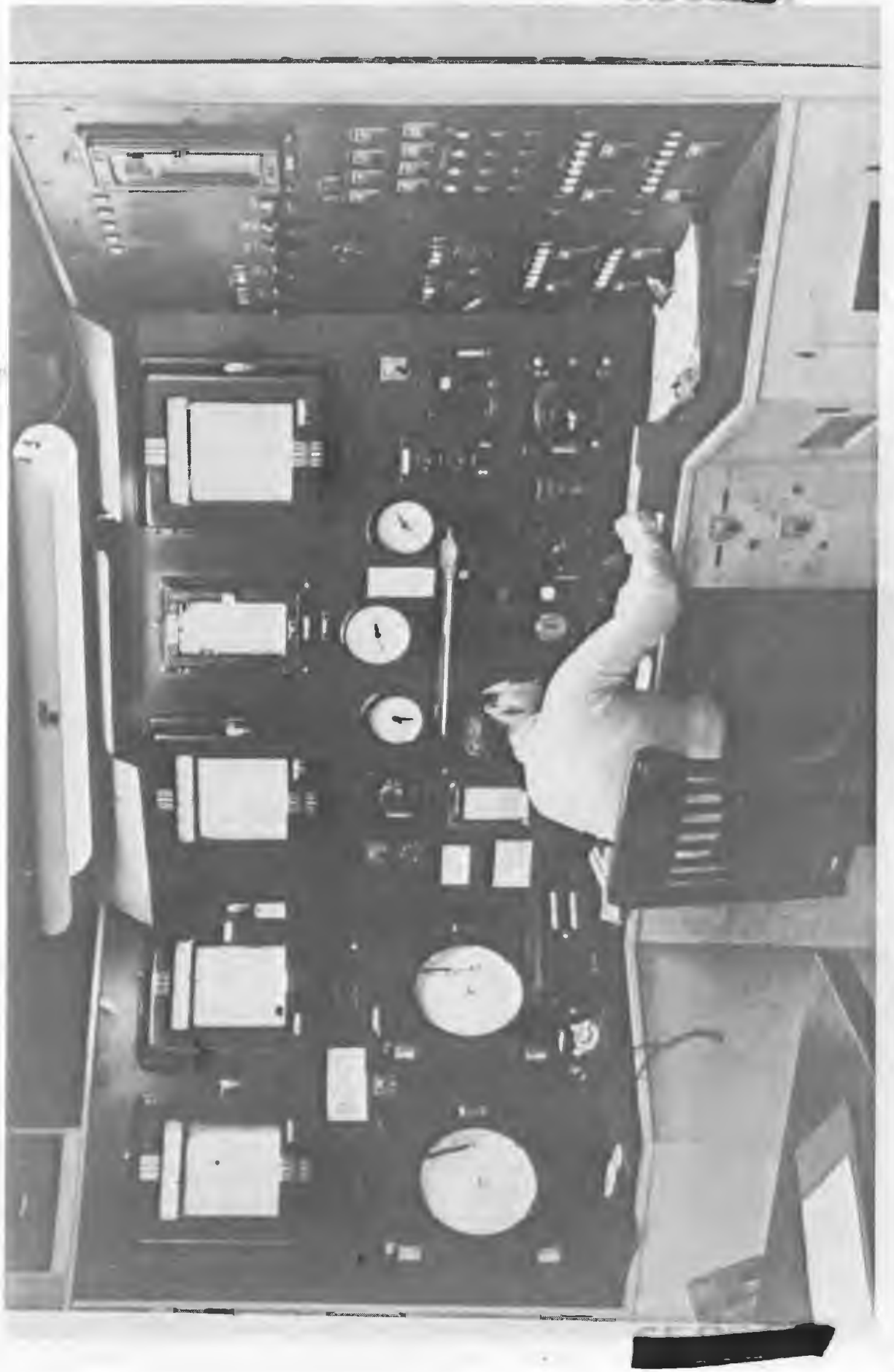



APPENDIX A 48

CHANGING FACE OF CLINTON LABORATORIES PILE

The electrically-operated elevator shown near the bottom of the photograph, serves as a loading platform.

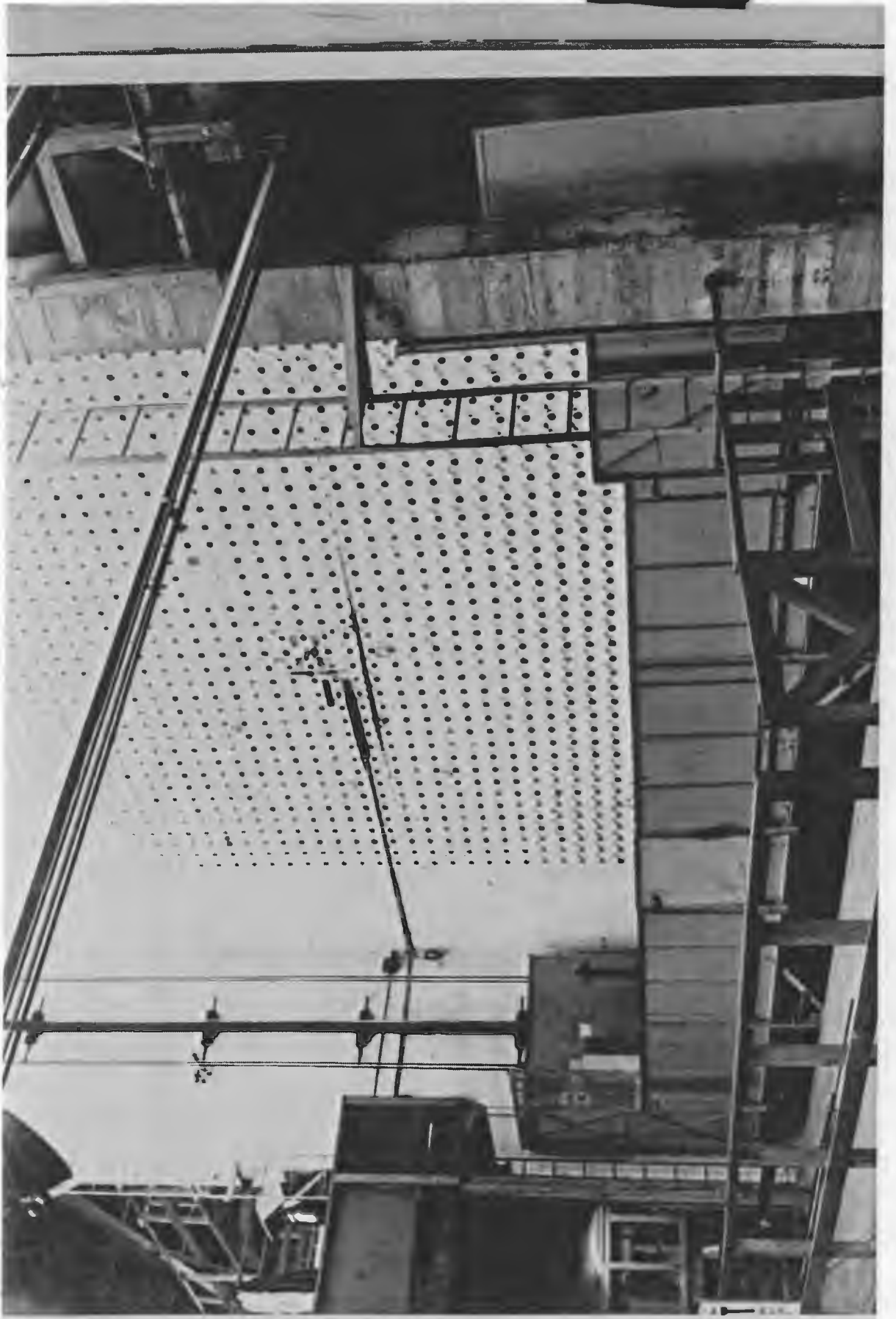

APPENDIX A 49

CHARGING FACE OF CLINTON LABORATORIES PILE

The elevator is shown near the bottom of the photograph. The Pile control panel is located on the platform at the left center of the photograph.

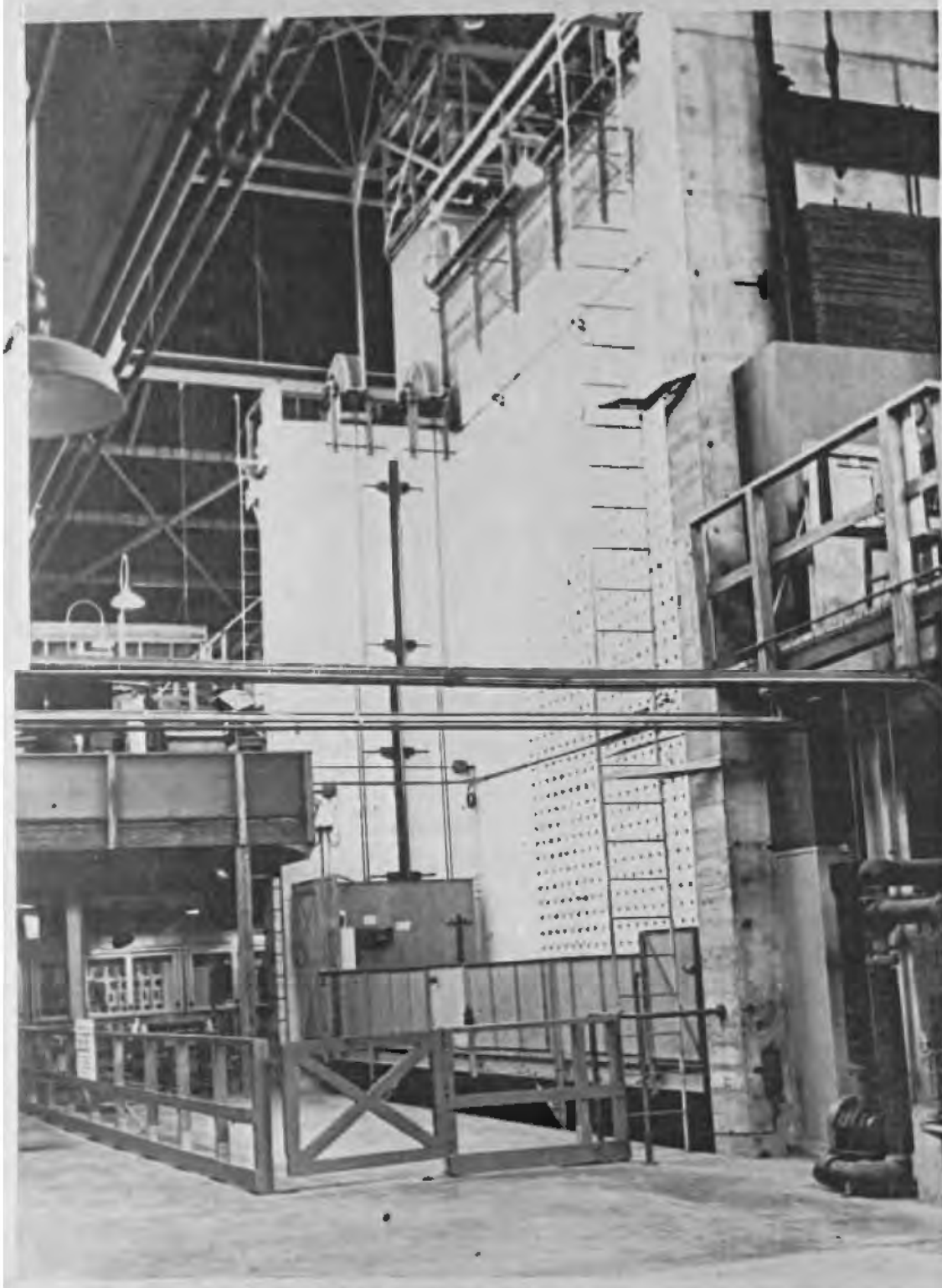

APPENDIX A 50

APPARATUS FOR CONSTANT SURVEILLANCE OF COOLING SYSTEM

The large electric motor, in the center of the photograph, drives one of the large fans used to circulate cooling air through the Pile. The small motors, valves, pipes, and gauges are part of the system which circulates oil continuously to all bearings of the motor and fan. The panel, at the right, contains continuous recording meters for making a permanent record of the temperature of the bearings, oil, and exit air.

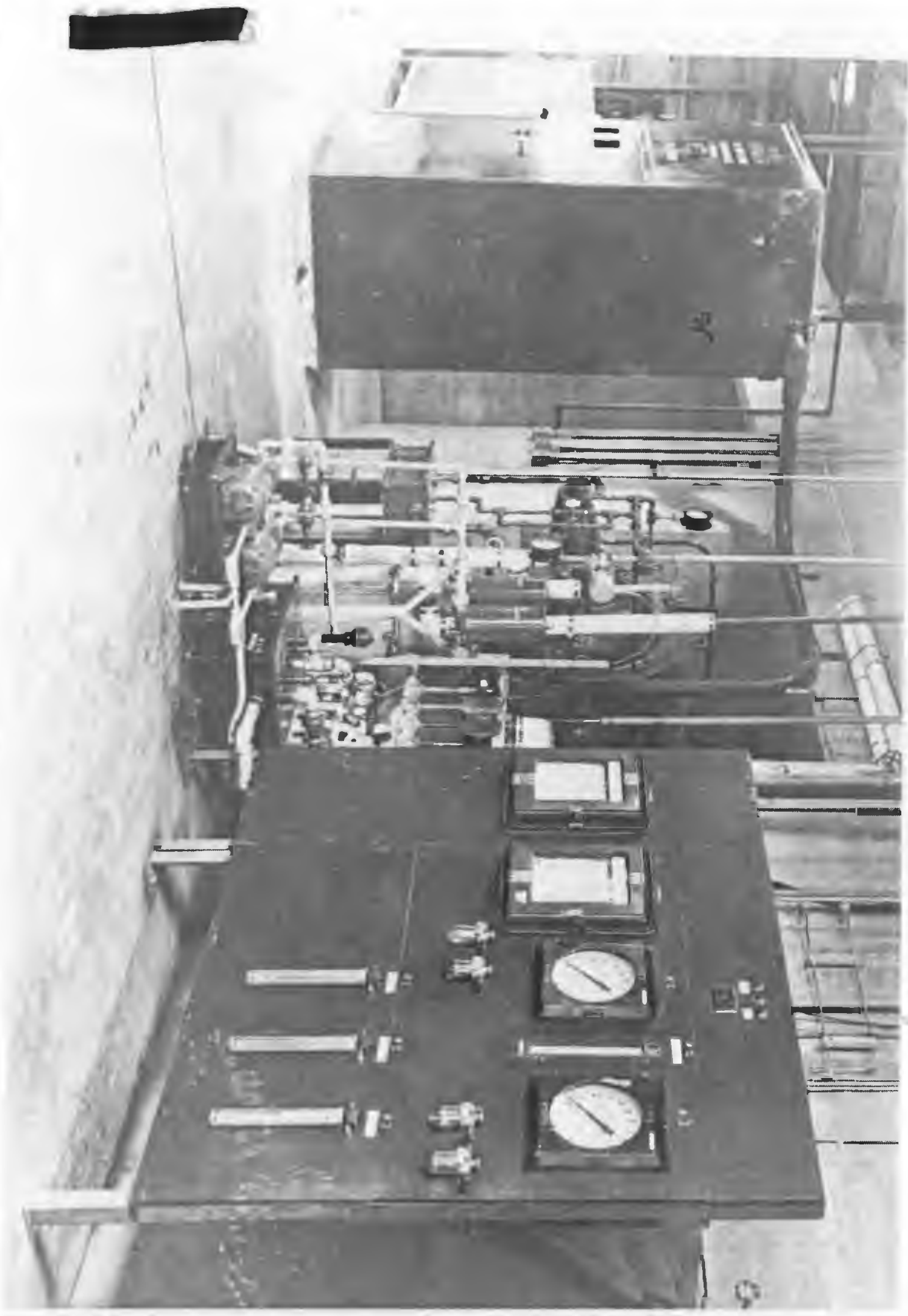

APPENDIX A 51

CONTROL PANELS IN SEMI-WORKS SEPARATION PLANT

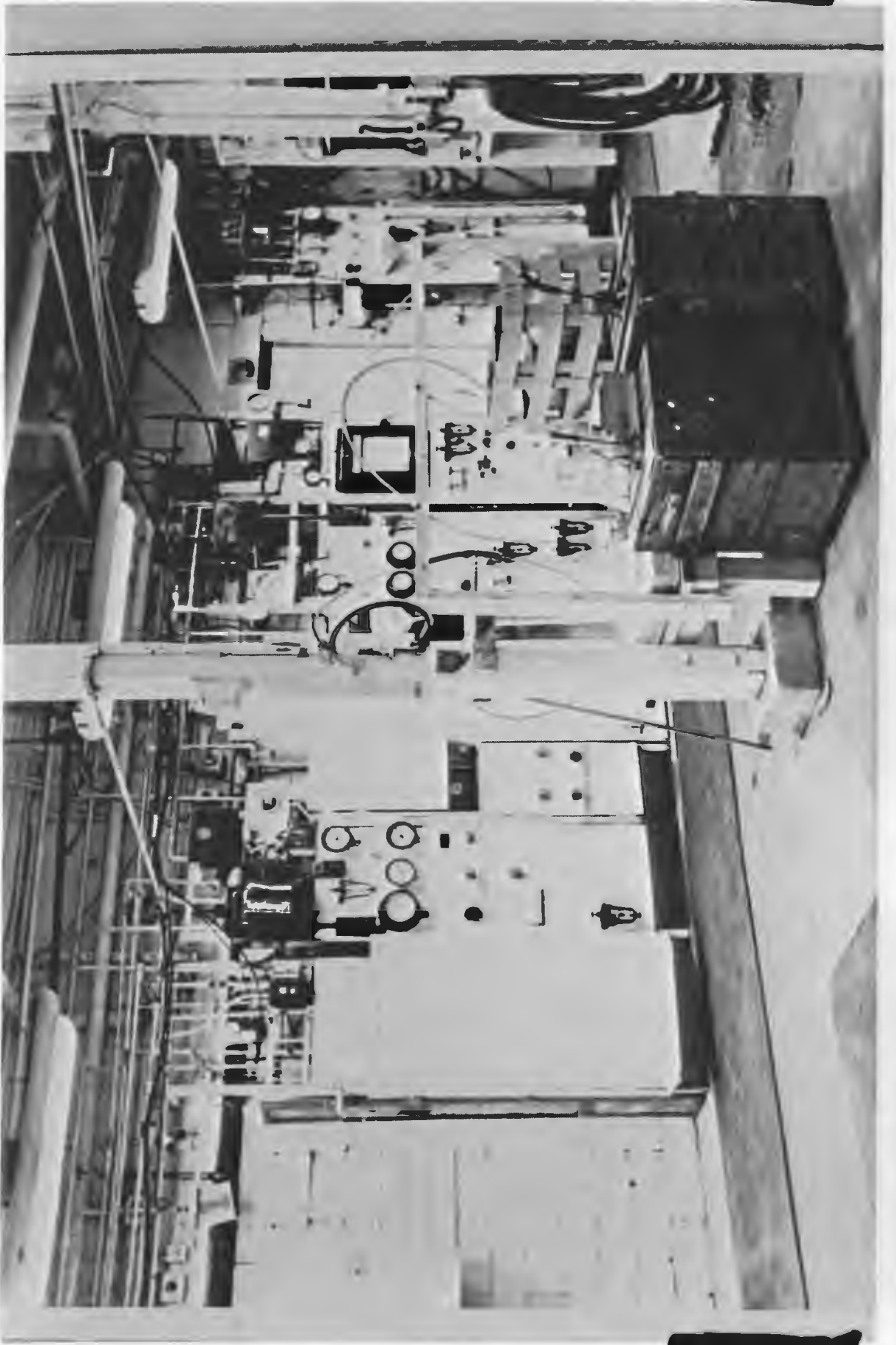



APPENDIX A 52

REMOTE CONTROL PANELS IN SEPARATION (205) BUILDING



APPENDIX A 53

TYPICAL COUNTING ROOM AT CLINTON LABORATORIES

These various groups of equipment are used in counting the radiation emitted from radioactive substances. In such rooms as this the progress and efficiency of the separation procedures were followed.



APPENDIX A 54

SECTION OF ISOLATION LABORATORY

The vessels, connecting pipes, and valves in the laboratory are made of stainless steel. All work in this laboratory was carried on under hoods to avoid inhalation of toxic vapors by operating personnel.

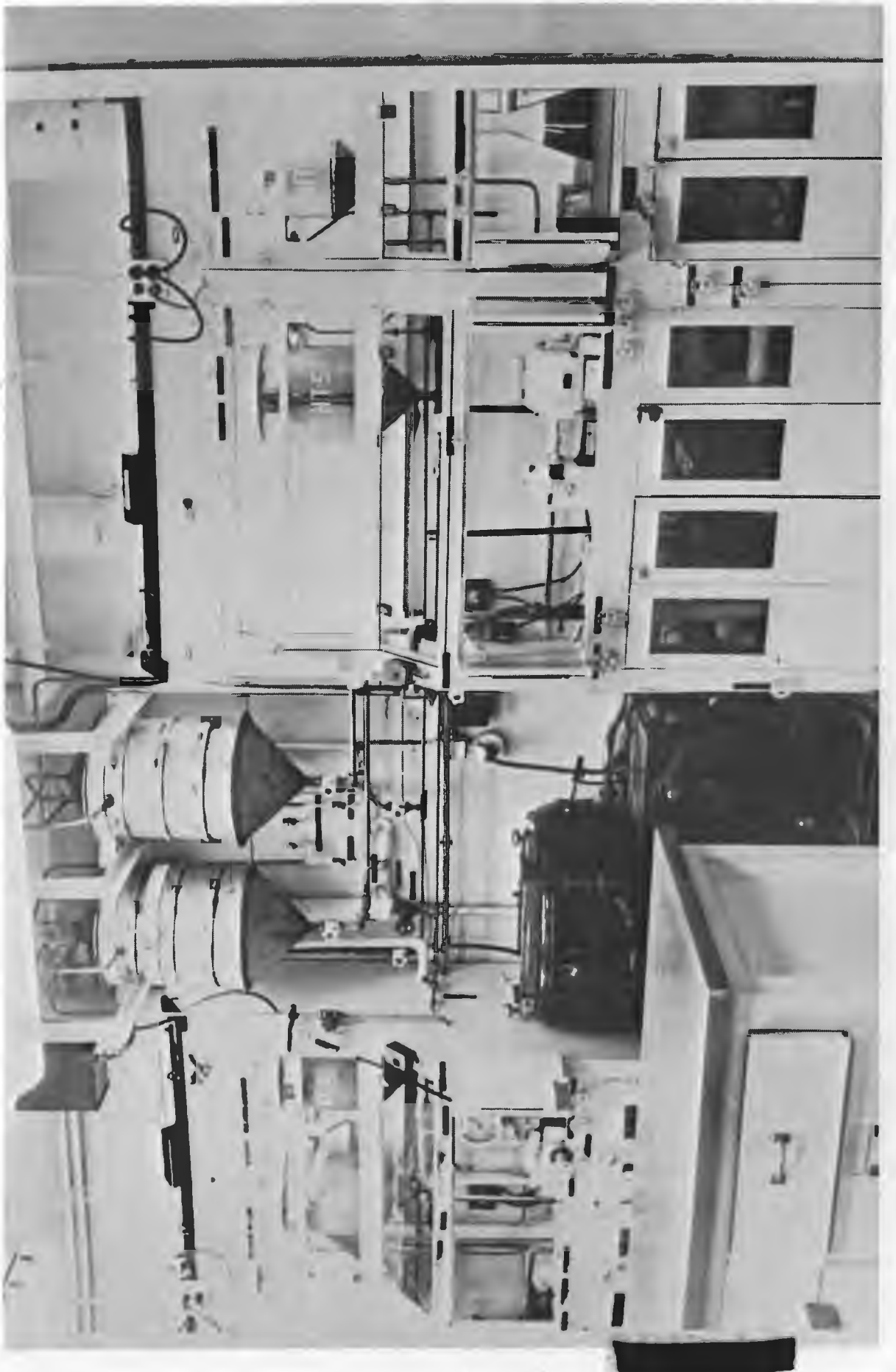

[REDACTED]

APPENDIX A 55

ELECTRIC OVENS FOR JACKET TESTING

These large electric ovens were used in testing the uranium slugs prior to their use in the Pile. The rack on the truck contains slugs ready for insertion into an oven. Slugs were subjected to a temperature of approximately 500 degrees Centigrade in these ovens for a period of about ten days.

[REDACTED]

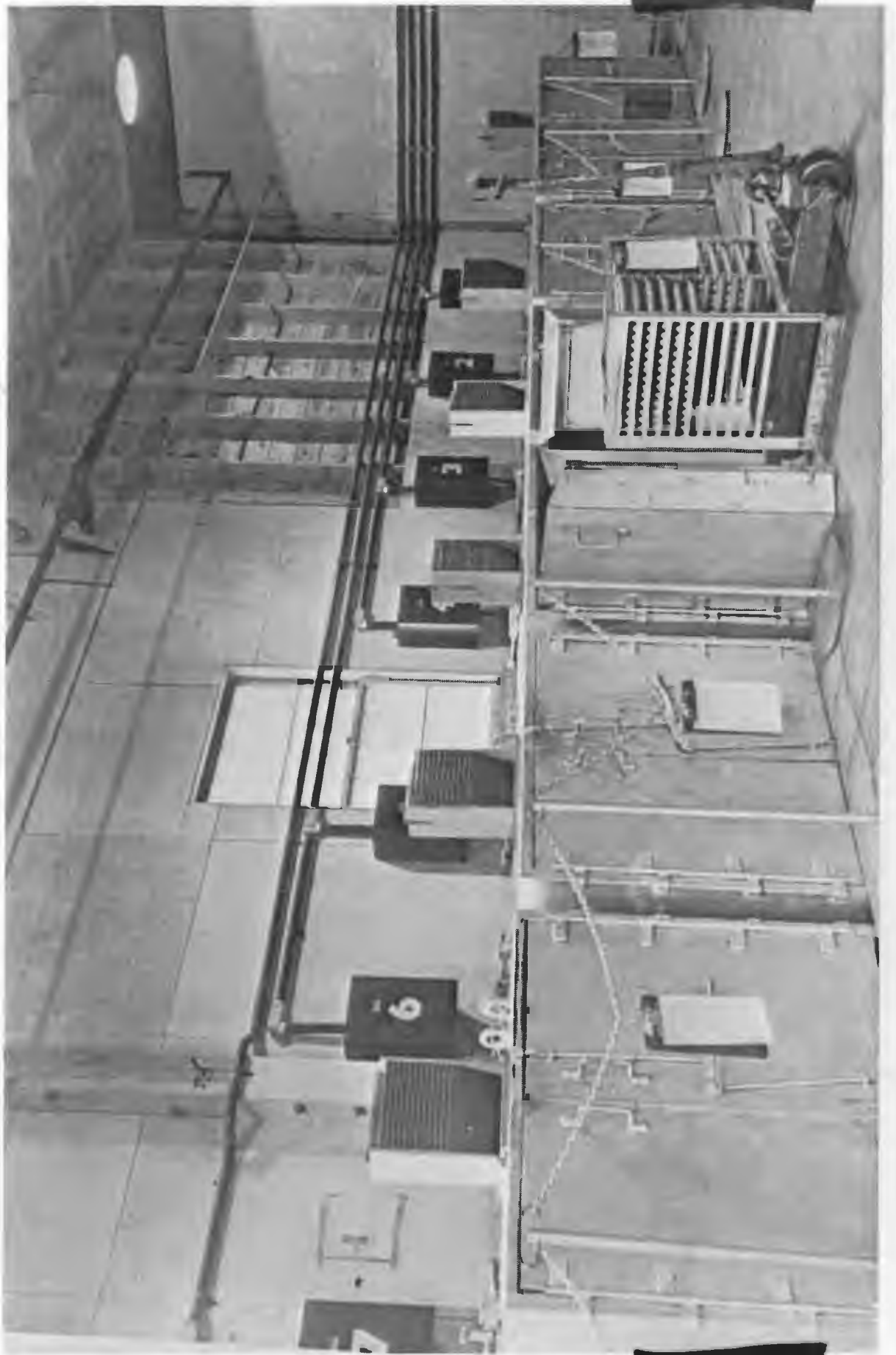



APPENDIX A-56

Bldg. No. 735-B - Training Building

4-56



TNX AREA

No. 735-B  
Training Building



54009

~~SECRET~~

2198

1/2

APPENDIX A-57

Bldg. No. 706-C - Chemistry Separations Laboratory  
(Concrete cell block in foreground)

~~SECRET~~

~~SECRET~~



A-31

TNX AREA  
Bldg. No. 706-C  
Chemistry Separations Laboratory  
(Concrete cell block in foreground)

54023

50095



(58324)

APPENDIX B  
CHARTS AND TABULATIONS

100-100000

22

MANHATTAN DISTRICT HISTORY

BOOK IV - PILE PROJECT

VOLUME 2 - RESEARCH

PART II - CLINTON LABORATORIES

APPENDIX B

CHARTS AND TABULATIONS

<u>No.</u>	<u>Description</u>
1	Tabulation of Clinton Laboratories Construction Subcontracts
2	Tabulation of Design Costs
3	Tabulation of Construction Costs (Project 9733)
4	Tabulation of Construction Costs (Project 58)
5	du Pont Engineering Department Organization Chart
6	Clinton Laboratories Organization Chart
7	Summary of Total Employees of Clinton Laboratories
8	Organization Chart of Monsanto Chemical Company, Clinton Laboratories



GLITCH LABORATORIES CONSTRUCTION SUBCONTRACTS

<u>ORDER NO.</u>	<u>CONTRACTOR</u>	<u>SCOPE OF WORK</u>	<u>COST OF WORK</u>
XPG 37½	Layne Central Company	Drilled and installed drinking water well.	\$ 6,950
XPG 38½	Link Belt Company	Furnished and erected coal handling equipment - Bldg. 801, Boiler house.	12,942
XPG 43	B. F. Shaw Company Cost Plus Fixed Fee Basis	Piping Subcontractor	550,000 10,000 (fee)
XPG 85	Emergy Construction Co.	Constructed temporary construction storage shed.	1,089
XPG 86½	Chicago Bridge & Iron Co.	Dismantled and re-erected elevated water storage tank.	9,200
XPG 105½	Rust Engineering Co.	Constructed three reinforced concrete chimneys for steam plant, pile and process buildings.	45,352
XPG 113½	J. E. Winans	Transported and erected two boilers in steam plant.	42,240
XPG 114½	Cement Gun Co., Inc.	Constructed 11 pre-stressed "Gumite" tanks.	92,256
XPG 161½	General Electric X-Ray Corporation	Furnished and installed X-Ray equipment in laboratory.	1,798
XPG 209	Johnson & Willard	Constructed Receiving and Storage Building.	5,141
XPG 231½	Haughton Elevator Co.	Furnished and erected one elevator in pile building.	15,506
XPG 252	Albert Bros. Contractors, Inc.	Excavating and grading contractors.	292,415

<u>ORDER NO.</u>	<u>CONTRACTOR</u>	<u>SCOPE OF WORK</u>	<u>COST OF WORK</u>
XPG 253	Johnson & Willard	Constructed Main Office Bldg.	\$ 28,937
XPG 224	Broadway Maintenance Corporation	Electrical subcontractor	75,152
XPG 397½	Warner Elevator Company	Furnished and installed one elevator in pile building.	5,228
XPG 543½	Grimesell Company, Inc.	Furnished and installed sprinkler systems in pile building and in chemical building.	11,700
XPG 456 & 740 A. J. Metler		Hauling contractor.	68,800
XPG 745½	Armstrong Cork Company	Insulating subcontractor.	36,800
XPG 927	J. D. Holton Roofing Co.	Roofing and waterproofing subcontractor	25,143
XPG 1384	Beery Construction Co.	Masonry subcontractor	21,000
XPG 1520	McCabe Construction Co.	Furnished and installed boiler brick work for steam plant.	17,020
XPG 2003	Young & Bertles Company	Furnished and installed duct work for separation process building.	8,000
XPG 2375	O'Neill Exterminating Co.	Fumigated Receiving & Stores Building.	75
XPG 3037	Chattanooga Boiler & Tank Co.	Repaired temporary sanitary boiler.	1,006
XPG 3230	Combustion Engineering Co.	Installed two new boiler tubes in steam plant.	182

NOTE: Contractual data covering these agreements are on file in the office of The District Engineer, U. S. Engineer Office, Manhattan District, P. O. Box 5, Oak Ridge, Tennessee (Contract Section).

TABULATION OF DESIGN COSTS

AREA

ENGINEERING DESIGN

PROJECT 9733

100	111,922.43
200	61,349.56
500	4,594.46
600	37,194.86
700	84,963.74
800	31,654.48
TC	6,148.47
TOTAL	337,828.00

PROJECT 58

300	32,859.14
500	49.77
600	272.09
TOTAL	33,181.00

CLASS	TITLE OR SUB-DIVISION	ACTUAL EXPENDITURES		COMMITMENTS	TOTAL (1+2+3)	% COMPLETE (4)	ESTIMATE TO C	
		LABOR (1)	MATERIAL (2)				LABOR (5)	MATERIAL (6)
ENGINEERING OVERHEAD ACCOUNTS								
AE	Engineering Design	286,431	47,377	7,996	336,803			
AF	Works Engineering	27,213	4,008	53,379	85,600			
AG	Engineering Supervision	186,598	88,503	7,250	282,671			
AH	Field Supervision	451,746	42,639	3,009	500,394			
AI	Field Expense	331,590	513,729	414	847,733			
CONSTRUCTION FACILITIES ACCOUNTS								
AJ	Construction Facilities (FD-M-R-S-JT)	107,135	110,000	51	217,210			
SUPPLIES ACCOUNTS								
AK	Miscellaneous Supplies							
AL	Subcontracts							
AM	Suspense Accounts		17,421	17,421 CR.				
GENERAL CONSTRUCTION ACCOUNTS								
AN	Site Work	2,379	2,177		25,556			
AO	General Grading	48,270	4,874		53,144			
AP	Extra Machinery		98,499		98,499			
AQ	Landscaping	4,040	336		5,276			
AR	100 Area	1,209,345	1,703,186	2,930	2,915,407			
AS	200 Area	783,589	819,463	3,207	1,606,659			
AT	500 Area	65,999	53,556		119,555			
AU	General Facilities Outside Lines	534,101	434,509		968,610			
AV	Service Area No. 1	1,291,883	916,927	401	2,209,231			
AW	Service Area No. 2	405,346	419,787		825,133			
GRAND TOTAL		5,766,064	5,293,735	56,642	11,105,841			77.99
Material furnished by Government without charge			1,030,417		1,030,417			
Materials transferred to other Government projects without suballotment			924,603		924,603			
Total amount charged against project appropriation		5,766,064	5,175,921	56,642	10,998,027			
Materials furnished and sold Direct by Government		502,874	816,394	66,453	1,385,721			
Materials transferred to other Government projects with suballotment								
Expenditures by the Post		5,263,190	4,359,527	10,411 CR.	9,632,928			

Memorandum:

17. Services and Materials furnished Operations

NOTE: Y-Account balance represents material charged to GEM by HEM for use by Clinton Laboratories. Credit to be given when material is returned to HEM. Materials transferred to other projects without suballotment-\$1,765 of material figure represents sales of salvage for which appropriation will not receive credit, because payment was made to Treasurer of U.S. instead of du Pont. \$16,134 of material figure is AFG material reallocated for use on HPG Orders (AFG 816 on HPG 285).

**T REPORT  
WORKS**

PERIOD ENDING June 30, 1945 Sheet 1

INCLUDES PAYROLL WEEK ENDING June 24, 1945

STATUS TO COMPLETE		INDICATED TOTAL COST			ESTIMATE DATED <u>6-6 thru 12-17</u> 19 <u>43</u>			REMARKS
MATERIAL	TOTAL (6+7)	LABOR (1+8)	MATERIAL (2+3+7)	TOTAL (9+10)	LABOR (11)	MATERIAL (12)	TOTAL (11+12)	
(13)	(14)	(15)	(16)	(17)	(18)	(19)	(20)	
						3,3,000	323,000	25% of Comm. is salary N.E. new account to record INA calculated as consultants on - 100%
						215,400	216,000	25% of Comm. is salary
					71,700	47,500	47,500	
					270,400	470,500	755,900	
					204,200	210,200	704,900	
					20,100	1,000	40,200	
					17,100	1,700	18,800	
					670	4,000	4,670	N. E. estimate included under 1944-45 costs in 1945
					1,070	500	4,100	
					1,000,000	1,770,000	2,000,000	
					690,000	600,000	2,070,000	
					59,000	49,000	109,000	
					510,000	500,000	1,070,000	
					1,029,000	1,190,510	2,421,510	
					401,100	401,000	802,100	
					4,859,000	6,577,700	11,197,000	

Manhattan District Direct  
payments for 1945. Charges:  
operatives - 2072,007  
Commitments - 200,000

FIELD FILE \_\_\_\_\_

CHECKED BY R. A. WHITE

APPROVED BY \_\_\_\_\_

CONSTRUCTION DIVISION

CODE	TITLE OR SUB-DIVISION	ACTUAL EXPENDITURES		COMMITMENTS	TOTAL (1+2+3)	% COMPLETE (4/5)	ESTIM. LABOR
		LABOR (1)	MATERIAL (2)				
FS	FIELD SUPERVISION						
FS-1	Construction Department - Clerical	171,067	15,485	611	187,163		
FS-2	Construction Department - Engineering	186,457	21,430	2,398	210,285		
FS-3	Accounting and Auditing Department	41,381	3,174		44,555		
FS-4	Purchasing Department	30,444	2,983		33,427		
FS-5	Order Division (Wilmington)	7,367	2		7,369		
FS-6	Expediting Division	13,728	1,547		15,265		
FS-7	Traffic Department	7,312	1,018		8,330		
	Sub-Total	457,746	45,639	3,009	506,394		
FE	FIELD EXPENSES						
FE-1	Fire Protection	3,966	458		4,424		
FE-2	Police Protection	110,296	235		110,531		
FE-3	Sanitation	6,120	2,101		8,221		
FE-4	Works Safety	18,282	4,953		23,235		
FE-5	Medical Services	17,948	6,802		24,750		
FE-6	Employment of Labor	91,387	70,873		162,260		
FE-7	Expendable General Office Supplies	3,650	80,782	413	84,845		
FE-8	Expendable Engineering Supplies and rental and repairs of Instruments	509	735		1,244		
FE-9	Light, Heat, Power and Water	168	2,022		2,190		
FE-10	Permit Fees		1,374		1,374		
FE-11	Insurance		116,104		116,104		
FE-12	Salaries of Chauffeurs for Plant Cars	5,731			5,731		
FE-13	Progress Photographs		135		135		
FE-14	Vacations	28,229	4,375		32,604		
FE-15	Liability Bonds	10,059	2,067		12,126		
FE-16	Fish and Employment Taxes		195,751		195,751		
FE-17	Penalties and F & B Group Life Insurance		16,497		16,497		
FE-18	Payment of Bonus in lieu of 7 days Notice						
FE-19	Blue Prints, Photostats	325	2,405		2,730		
FE-20	Wilmington Office - Blue Prints, Photostats	199	11,070	1	11,070		
FE-21	Moving Temporary Office to Plant Site	1,390	27		1,417		
FE-22	Military Roll	1,825			1,825		
FE-23	Travel and Expense Supplies - Weather, Special Barracks	2,010	8,497		10,507		
	Sub-Total	333,590	514,749	414	847,733		
TC	TEMPORARY CONSTRUCTION						
TC-1	Temporary Construction	100,000	59,176	51	159,227		
TC-2	Labor Equipment	1,375	17,039		18,414		
TC-3	Labor Equipment Insurance						
TC-4	Material Equipment	138	8,800		8,938		
TC-5	Material Equipment Insurance						
TC-6	Material Tools	4,795	11,117		15,912		
TC-7	Material Misc. Materials						
	Sub-Total	106,208	88,132	51	194,391		

**T REPORT**  
**WORKS**

PERIOD ENDING FEBRUARY 28, 19 65

INCLUDED PAYROLL WEEK ENDING JANUARY 31, 19 65

TO COMPLETE MATERIAL (1)	TOTAL (2+3) (2)	INDICATED TOTAL COST			ESTIMATE DATED			REMARKS
		LABOR (144) (3)	MATERIAL (145) (4)	TOTAL (146) (5)	LABOR (147) (6)	MATERIAL (148) (7)	TOTAL (149) (8)	
					371,790	47,500	419,290	
					371,790	47,500	419,290	
					138,090	145,000	283,090	
					138,310	2,500	140,810	
						170,000	170,000	
						162,000	162,000	
					276,400	479,500	755,900	
					171,650	134,400	306,050	
					4,870	240,000	244,870	
					12,190	161,700	173,890	
					188,710	536,100	724,810	

**SECRET**

PROJECT NO 9733 ACCOUNT 0-1

MONTHLY C  
OF INCOME STATEMENT

CONSTRUCTION DIVISION

CODE	TITLE OR SUBDIVISION	ACTUAL EXPENDITURES		COMMITMENTS	TOTAL (1 + 2 + 3)	EMPLOYEES (FTE)	ESTIM LABOR
		LABOR (1)	MATERIAL (2)				
Y	100 AREA ACCOUNTS						
Y-1	Craft Superintendents, Paint, Drives, etc. hauling, etc. not chargeable to specific Equip.						
Y-3	Useful Items						
Y-13	Computers		17,421	CR. 17,421			
Y-14	Miscellaneous Instruments						
Y-15	Servicing of Government Equipment						
Y-20	Maintenance of Roads						
	Sub Total		17,421	CR. 17,421			
	MATERIAL ACCOUNTS						
100	100 Area						
101-B	101 Building	47,100	16,445		63,545		
101-E	101 Equipment	25,493	25,093		50,586		
102-B	102 Building	9,304	3,654		12,958		
102-E	102 Equipment	492	3,426		3,918		
103-B	103 Building	1,090	970		2,060		
103-E	103 Equipment	211,993	129,177		341,170		
105-E	105 Equipment	709,799	1,457,151	2,99	2,200,626		
115-B	115 Building	77,054	25,220		102,274		
115-E	115 Equipment	64,785	41,297		106,082		
	Sub Total	1,009,345	1,705,108	2,99	2,915,257		
200	200 Area						
204-E	204 Equipment	5,293	2,400		7,693		
204-E	204 Equipment	7,426	12,475	1	20,162		
205-B	205 Building	201,822	95,917		297,739		
205-E	205 Equipment	405,795	545,349	1,266	950,050		
206-E	206 Equipment	163,253	165,820		329,073		
	Sub Total	783,569	819,861	3,267	1,606,697		
500	Outside Electric Lines						
501	Electric Substation and Outside Wiring	65,999	53,666		119,555		
	Sub Total	65,999	53,666		119,555		





RAIL CONSTRUCTION DIVISION

CODE	TITLE OR SUB-DIVISION	ACTUAL EXPENDITURES		COMMITMENTS	TOTAL (7+8+9)	ESTIMATE LABOR
		LABOR	MATERIAL			
		(1)	(2)	(3)	(4)	(5)
600	General Facilities Outside Lines					
603	Roads and Walks	88,259	142,546		230,805	
604	Autos, Trucks and Cranes	1,822	11,081		12,903	
605	Fences	23,973	5,163		29,136	
612	Open Drainage Ditches	4,796	2,417		7,213	
613	Permanent Parking Lot	2,753	1,401		4,154	
614	Guard Towers	6,450	4,904		11,354	
615	Fence Lighting	8,184	6,456		14,640	
622	Overhead Steam	46,471	19,797		66,268	
623	Underground Water	125,483	124,917		250,400	
624	Air Lines	2,518	671		3,189	
625	Sewers and Septic Tanks	42,425	25,678		68,103	
628	Process Lines and Sewers	97,024	55,369		152,393	
630	Fire Protection	39,077	18,098		57,175	
631	Outside Overhead Line Supports	25,433	7,853		33,286	
632	Dam and Sluice Gate	19,433	8,158		27,591	
	Sub Total	534,101	434,509		968,610	
700	Service Area No. 1					
701-B	Gate House and Clock Alley Building	14,556	5,359		19,915	
701-E	Gate House and Clock Alley Equipment	4,541	4,275		8,816	
702-E	Telephone System	1,631	4,019		5,650	
703-B	Main Office Building	104,016	63,718		167,734	
703-E	Main Office Equipment	7,033	22,407		29,440	
704-E	Supervisor's Office Building	4,429	1,614		6,043	
704-E	Supervisor's Office Equipment	143	62		205	
706-B	Laboratory Building	391,081	161,930		553,011	
706-E	Laboratory Equipment	291,844	321,364	250	615,458	
707-B	Change House Building	38,977	16,913		55,890	
707-E	Change House Equipment	1,837	2,777		4,614	
708-B	Cafeteria Building	60,459	17,268		77,727	
708-E	Cafeteria Equipment	18,205	20,608		38,813	
713-B	General Storehouse Building	64,231	27,714		91,944	
713-E	General Storehouse Equipment	4,988	2,263		7,251	
714-B	Storage Platform	12,174	4,524		16,698	
715-E	Flag Pole and Flags	38	35		73	
717-B	Shop and Supply Storage House Building	84,899	39,421		124,320	
717-E	Shop and Supply Storage House Equipment	10,551	76,457	171	95,179	
719-B	First Aid House and Service Building	52,337	25,877		78,214	
719-E	First Aid House and Service Equipment	15,772	53,753		69,525	
720-B	Patrol Headquarters Building	23,657	9,167		32,824	
720-E	Patrol Headquarters Equipment	1,416	47		1,463	
723-B	Laundry Building	10,179	5,514		15,693	
723-E	Laundry Equipment	4,247	3,607		7,854	
724-B	Bus Station Equipment	943	546		1,489	

PERIOD ENDING Feb. 28 1943

INCLUDES PAYROLL WEEK ENDING January 31, 1943

REPORT  
WORKS

NO.	INDICATED TOTAL COST			ESTIMATE DATED			REMARKS
	TOTAL 2197	LABOR 0126	MATERIAL 2171	LABOR 0126	MATERIAL 0126	TOTAL 0126	
				97,130	131,800	228,930	
				6,700	56,900	63,600	
				13,160	4,400	17,560	
				910	1,350	2,260	
				1,830	6,000	7,830	
				6,590	5,350	11,940	
				6,340	7,500	13,840	
				18,100	19,100	37,200	
				128,680	131,000	259,680	
				7,800	4,070	11,870	
				17,900	12,000	29,900	
				123,990	126,000	249,990	
				40,130	36,700	76,830	
				20,540	12,230	32,770	
				21,930	12,000	33,930	
				513,930	566,000	1,079,930	
				8,620	6,580	15,200	
				3,500	6,990	10,490	
				1,880	44,000	45,880	
				59,740	57,300	117,040	
				5,710	35,500	41,210	
				312,590	215,900	528,490	
				356,960	508,800	865,760	
				25,050	19,760	44,810	
				1,680	2,080	3,760	
				45,460	24,900	70,360	
				13,470	28,500	41,970	
				19,980	12,000	31,980	
				120	1,500	1,620	
				2,440	2,500	4,940	
				120	100	220	
				39,490	27,900	67,390	
				22,800	63,300	86,100	
				33,750	27,900	61,650	
				12,060	55,600	67,660	
				20,860	10,000	30,860	
				2,320	7,000	9,320	
				8,970	3,970	12,940	
				3,910	8,230	12,140	
				1,220	600	1,820	



PROJECT NO. 9733

ACCOUNT C-1

## MONTHLY COST REPORT

CLINTON &amp; NEIDER WORKS

RAIL CONSTRUCTION DIVISION

CODE	TITLE OR SUB-DIVISION	ACTUAL EXPENDITURES		COMMITMENTS (b)	TOTAL (1 + 2 + 3) (c)	% COMPLETE (Paper) (d)	ESTIMATE TO COMPLETION	
		LABOR (a)	MATERIAL (b)				LABOR (e)	MATERIAL (f)
	Service Area No. 1 Cont'd.							
725-B	Parking Garage Building	20,723	6,257		26,980			
725-C	Parking Garage Equipment	2,937	2,150		5,087			
726-A	Tricone Storage - Tanks & O.S. Lines	11,626	4,967		16,593			
729-B	Spare Machinery Storage Building	2,665	876		2,961			
735-F	Training School Building	20,278	7,665		28,143			
735-G	Training School Equipment	752	1,742		2,550			
737-C	Wain Shelter Building	743	139		882			
745-A	Wistol Range	112	114		233			
	Sub Total	1,291,283	916,927	421	2,209,231			
	Service Area No. 2							
801-B	Boiler House Building	73,008	43,740		117,408			
801-C	Boiler House Equipment	124,455	100,737		225,192			
802-A	Reservoir Equipment	13,088	9,640		23,328			
809-A	Surge Reservoir	6,840	39,470		46,320			
807-A	Water Treatment House Building	25,041	9,005		34,046			
807-B	Water Treatment House Equipment	48,793	55,603		104,456			
811-B	Springing Water Well Building	792	178		970			
811-C	Springing Water Well Equipment	3,006	8,049		11,113			
812-B	Reservoir Pump House Building	5,235	1,907		7,144			
812-C	Reservoir Pump House Equipment	16,823	14,779		22,002			
813-A	Filter Plant Building	17,110	8,000		25,351			
813-B	Filter Plant Equipment	25,734	30,557		62,554			
814-A	River Pump House Building	27,800	11,244		43,112			
814-B	River Pump House Equipment	8,220	12,547		18,793			
815-A	Overhead Water Storage Tank	15,372	10,162		25,734			
	Sub Total	475,348	419,767		895,113			

**REPORT  
WORKS**

Sheet #5

PERIOD ENDING Feb. 28, 1965

INCLUDES PAYROLL WEEK ENDING Jan. 31, 1965

PERCENT COMPLETE	INDICATED TOTAL COST				ESTIMATE DATED			REMARKS
	TOTAL (6+7) (6)	LABOR (1+6) (6)	MATERIAL (2+3+7) (6)	TOTAL (6+7) (6)	LABOR (6) (6)	MATERIAL (6) (6)	TOTAL (11+12) (6)	
					5,120	4,000	9,120	
					850	2,200	3,050	
					5,290	6,300	11,790	
					12,920	8,700	21,620	
					1,220	4,000	5,220	
					930	200	1,130	
					<b>1,029,030</b>	<b>1,192,510</b>	<b>2,221,540</b>	
					53,620	41,100	94,720	
					164,510	155,000	319,510	
					12,800	13,300	26,100	
					2,440	54,500	56,940	
					20,590	12,300	32,890	
					30,830	67,100	97,930	
					210	100	310	
					5,240	7,700	12,940	
					3,050	1,800	4,850	
					5,360	13,300	18,660	
					10,450	11,500	21,950	
					31,600	39,000	70,600	
					29,860	21,000	50,860	
					7,550	13,000	20,550	
					<b>116,940</b>	<b>10,800</b>	<b>127,740</b>	
					<b>401,160</b>	<b>401,000</b>	<b>802,160</b>	

PROJECT NO. 38 ACCOUNT 52  
 WAR CONSTRUCTION DIVISION

MONTHLY COST REPORT  
 CLINTON ENGINEERING WORK

CODE	TITLE OR SUB-DIVISION	ACTUAL EXPENDITURES		COMMITMENTS	TOTAL (1+2+3)	COMPLETE (Percent) (4)	ESTIMATE TO COMPLETE	
		LABOR (1)	MATERIAL (2)				LABOR (5)	MATERIAL (6)
SPECIALIZED ACCOUNTS								
ED	Engineering Design	28,993	2,789	1,398	33,180			
ES	Engineering Supervision	10,746	1,935	154	12,835			
FS	Field Supervision	15,102	605	754	16,521			
FE	Field Expense	4,834	8,703	1	13,538			
GENERAL CONSTRUCTION ACCOUNTS								
EM	Extra Machinery		124		124			
300	300 Area	70,378	157,075		227,453			
500	500 Area	227	117		344			
600	600 Area	1,110	784		1,894			
	Materials furnished by Government without charge	131,450	172,132	2,307	305,889	95.99		
	Materials transferred to other Government projects without suballotment		16,012		16,012			
	Total amount charged against project appropriation	131,450	188,144	2,307	321,901			
	Materials furnished and paid direct by Government	35,043	6,043	2,307	43,393			
	Materials transferred to other Government projects with suballotment							
	Expenditures by client	96,407	152,933		249,340			

**ST REPORT**

WORKS

PERIOD ENDING Feb. 28, 1945 Sheet 1

INCLUDES PAYROLL WEEK ENDING Jan. 31, 1945

PERCENTAGE TO COMPLETE

PERCENTAGE TO COMPLETE		INDICATED TOTAL COST			ESTIMATE DATED			REMARKS
MATERIAL (1)	TOTAL (2+3+7)	LABOR (4+5)	MATERIAL (6+3+7)	TOTAL (8+10)	LABOR (4)	MATERIAL (6)	TOTAL (11+13)	
						20,000	20,000	3383 of Comm. is Salary
						3,700	3,700	127 of Comm. is Salary
					7,10	800	8,010	
					6,030	12,500	18,530	
					162,150	160,100	322,250	
					270	250	520	
					1,100	880	1,980	
					176,770	161,430	338,200	



Manhattan District Direct  
 Payments for Film Charges:  
 Expenditures - \$1,286  
 Commitments - \$1,287

PAID BY \_\_\_\_\_  
 RECEIVED \_\_\_\_\_  
 BY \_\_\_\_\_

PROJECT NO 58 ACCOUNT No. 2

CONSTRUCTION DIVISION

MONTHLY CO

ESTIMATE

CODE	TITLE OR SUB-DIVISION	ACTUAL EXPENDITURES		COMMITMENTS	TOTAL (1+2+3)	ESTIMATE LABOR
		LABOR (1)	MATERIAL (2)			
F0	FIELD SUPERVISION					
F0-1	Construction Department - Clerical	3,312	-		3,312	
F0-2	Construction Department - Engineering	9,790	605		10,395	
F0-3	Accounting and Auditing Department	888	-	754	1,642	
F0-4	Purchasing Department	508	-		508	
F0-5	Order Division (Wilmington)	115	-		115	
F0-6	Expediting Division	391	-		391	
F0-7	Traffic Department	158	-		158	
	Sub Total	15,162	605	754	16,521	
F1	FIELD EXPENSE					
F1-1	Fire Protection	68	-		68	
F1-2	Police Protection	2,267	-		2,267	
F1-3	Sanitation	105	36		141	
F1-4	Work Safety	199	80		279	
F1-5	Medical Services	377	44		421	
F1-6	Employment of Labor	1,598	1,466		3,064	
F1-7	Expensable General Office Supplies Expensable Engineering Supplies and Rentals and Repairs of Instruments	11	1,468		1,479	
F1-8	Light, Heat, Power and Water	-	36		36	
F1-10	Permit Fee	-	-		-	
F1-11	Insurance	-	1,278		1,278	
F1-12	Salaries of Operators of Plant Cars	101	-		101	
F1-13	Progress Photographs	-	-		-	
F1-14	Vacations	-	-		-	
F1-15	Disability Wage	-	-		-	
F1-16	Food and Unemployment Taxes	-	3,402		3,402	
F1-18	Pensions and A. & H. and Group Life Ins.	-	298		298	
F1-19	Payment of Wages in Lieu of 7 Days' Notice	-	-		-	
F1-22	Blue Print, Photostats	19	37		56	
F1-23	Wilmington Office - Blue Prints, Photostats	231	775		997	
F1-24	Moving Temporary Offices to Plant Site	-	-		-	
F1-25	Military Roll	-	-		-	
	Sub Total	15,036	6,701	1,000	22,737	



**ST REPORT**

WORKS

Sheet #2

PERIOD ENDING Feb. 28, 1945

WORK TO COMPLETE

INCLUDES PAYROLL WEEK ENDING January 31, 1945

MATERIAL (1)	TOTAL (1+7)	INDICATED TOTAL COST			ESTIMATE DATED			REMARKS
		LABOR (1+8) (2)	MATERIAL (2+3+7) (3)	TOTAL (2+3) (11)	LABOR (12)	MATERIAL (13)	TOTAL (12+13) (14)	
					7,210	800	8,010	

7,210	800	8,010
1,720	2,400	4,120
4,310		4,310

4,900 4,900

5,200 5,200



PROJECT NO. 58

ACCOUNT NO. C-2

CONSTRUCTION DIVISION

MONTHLY COST REPORT

CODE	TITLE OR SUB-DIVISION	ACTUAL EXPENDITURES		COMMITMENTS	TOTAL (1+2+3)	ESTIMATE LABOR
		LABOR (1)	MATERIAL (2)			
	GENERAL CONTRACTOR					
300	300					
305-B	305 Building	467	348		815	
305-C	305 Equipment					
	Sub-Total	467	348		815	
500	500	69,911	156,727		226,638	
501	501	70,378	157,075		227,453	
502	502					
503	503					
504	504					
505	505					
506	506					
507	507					
508	508					
509	509					
510	510					
511	511					
	Sub-Total	1,110	784		1,894	

LY COST REPORT

PERIOD ENDING February 28, 1945

WORKS

INCLUDES PAYROLL WEEK ENDING February 11, 1945

ESTIMATE TO COMPLETE			INDICATED TOTAL COST			ESTIMATE DATED			REMARKS
LABOR (1)	MATERIAL (2)	TOTAL (1+2)	LABOR (3+4)	MATERIAL (5+6)	TOTAL (3+6)	LABOR (7)	MATERIAL (8)	TOTAL (7+8)	
						18,950	14,100	29,050	
						143,210	150,000	293,210	
						162,160	166,100	322,260	
						270	250	520	
						270	250	520	
						430	320	750	
						130	40	170	
						230	190	420	
						240	280	520	
						70	50	120	
						1,100	880	1,980	

E. I. DU PONT DE NEMOURS & CO. (INC.)  
 ENGINEERING DEPARTMENT  
 Design and Construction Divisions  
 Manhattan District - Organization Chart

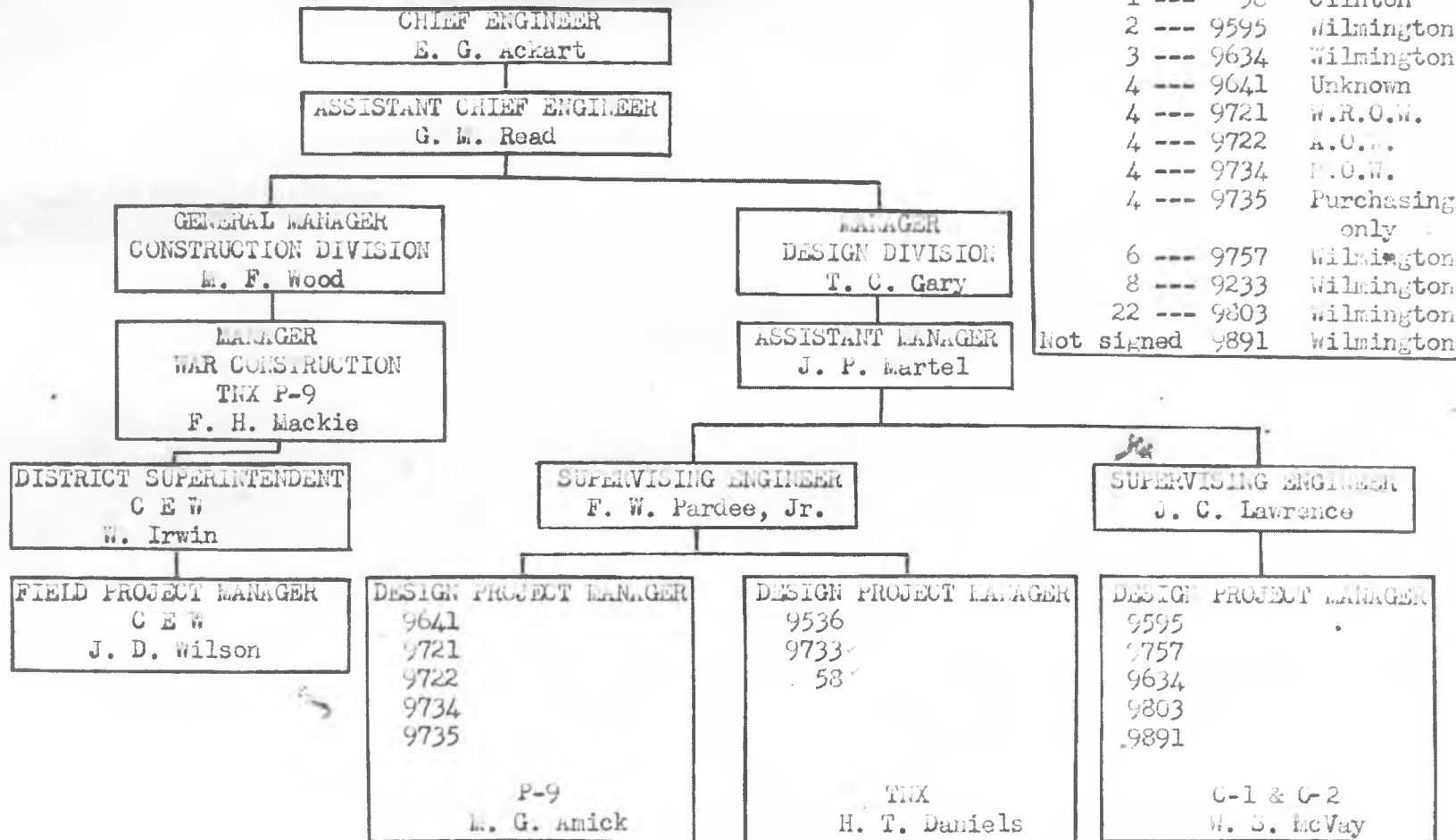

KEY		
CONTRACT	PROJECT	LOCATION
1 ---	9536	Hanford
23 ---	9733	Clinton
1 ---	58	Clinton
2 ---	9595	Wilmington
3 ---	9634	Wilmington
4 ---	9641	Unknown
4 ---	9721	W.R.O.W.
4 ---	9722	A.O.W.
4 ---	9734	M.O.W.
4 ---	9735	Purchasing only
6 ---	9757	Wilmington
8 ---	9233	Wilmington
22 ---	9803	Wilmington
Not signed	9891	Wilmington

ORGANIZATION CHART  
CLINTON LABORATORIES

Director - M. D. Whitaker

Associate Director (Research) - R. L. Doan

Special Asst. - L. B. Borst

Division Director (Chemistry) - W. C. Johnson

Division Director (Separations Development) - O. H. Greager

Division Director (Analytical) - D. M. Smith

Health Division Director - S. T. Cantril

Plant Manager - S. W. Pratt

Production Supt. - W. C. Kay

Works Engineer - A. J. Schwertfeger

Service Supt. - R. A. Wentworth

Chief Accountant - E. C. Weber

ORGANIZATION CHART

CLINTON LABORATORIES

RESEARCH AND DEVELOPMENT

CHEMISTRY DIVISION

Division Director - W. C. Johnson

Asst. to Director - H. S. Brown

Section I - Section Chief - I. Perlman

Section II - Section Chief - C. D. Coryell

Section III - Section Chief - G. E. Boyd

SEPARATION DEVELOPMENT DIVISION

Division Director - O. H. Greager

Section S-I - Section Chief - M. F. Acken

Semi-Works Group - Group Leader - D. H. Johnson

Process Group - Group Leader - R. S. Apple

Section S-II - Section Chief - J. E. Sutton

PHYSICS SECTION

Section I - Section Chief - H. W. Newson

Section II - Section Chief - L. W. Nordheim

ENGINEERING DEVELOPMENT SECTION

Section Chief - M. C. Leverett

BIOLOGICAL SECTION

Section Chief - H. J. Curtis

RESEARCH AND DEVELOPMENT

(cont'd)

ANALYTICAL DIVISION

Division Director - D. M. Smith

Chief Supervisor - G. J. Struthers

I. Control Section, Senior Supvr. - R. B. Fenninger

II. Special Analyses Section, Senior Supvr. - M. R. Hoff

III. Analytical Development section, Senior Supvr.-R. M. Coleman

ORGANIZATION CHART  
CLINION LABORATORIES

HEALTH DIVISION

Division Director - S. T. Cantril, M. D.

Physicians

Clinical Laboratory - Head Technician - Melba Johnston

Nurses

Health Physics - Section Chief - H. M. Parker



ORGANIZATION CHART  
CLINTON LABORATORIES

PLANT

Manager - S. W. Pratt

Production Supt. - W. C. Kay

100 Area Asst. Supt. - J. P. Sinclair

200 Area Asst. Supt. - F. B. Vaughan

Works Engineer - A. J. Schwertfeger

Power - Asst. Supt. - J. D. Renfroe

Maintenance - Asst. Supt. - K. D. Wallace

Instruments - Asst. Supt. - W. P. Overbeck

Project Engineer - M. S. Smith

Transportation & Traffic - Chief Supervisor - F. C. Rose, Jr.

Area Engineer - Special Assignment - W. D. Webb

Service Supt. - R. A. Wentworth

Asst. Service Supt. - J. R. Henson

Chief Accountant - E. C. Weber

Asst. Chief Accountant - E. C. Manners

[REDACTED]

SUMMARY OF TOTAL EMPLOYEES OF CLINTON LABORATORIES

<u>MONTH</u>	<u>YEAR</u>	<u>TOTAL NO. OF EMPLOYEES</u>
April	1943	11
May	"	22
June	"	39
July	"	64
August	"	236
September	"	353
October	"	634
November	"	787
December	"	882
January	1944	1022
February	"	1166
March	"	1359
April	"	1456
May	"	1470
June	"	1513
July	"	1491
August	"	1443
September	"	1328
October	"	1287
November	"	1273
December	"	1291
January	1945	1317
February	"	1268
March	"	1222
April	"	1159
May	"	1084
June	"	1088

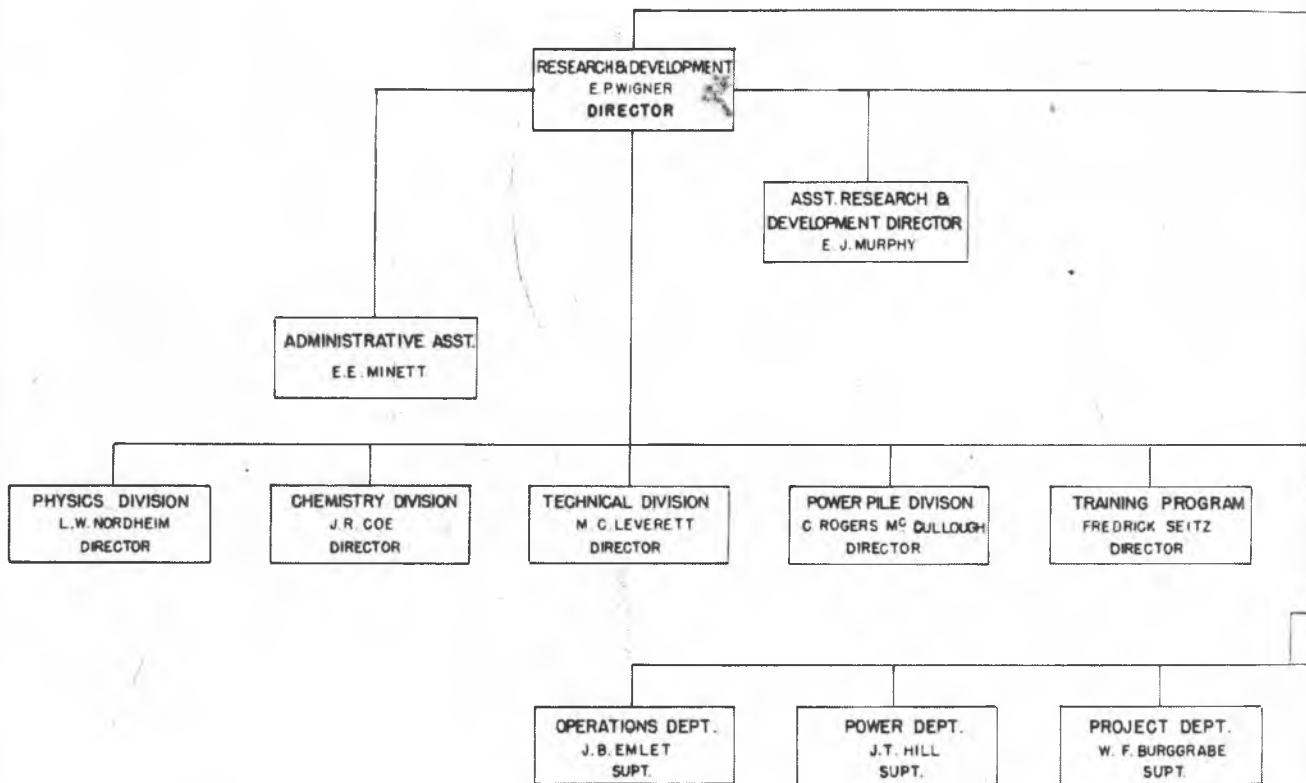

PROJECT DIRECTOR  
A THOMAS

EXECUTIVE DIRECTOR  
J H LUM

ASST EXECUTIVE  
DIRECTOR  
PRESCOTT SANDIDGE

BIOLOGY DIVISION  
ALEXANDER HOLLANDER  
DIRECTOR

METALLURGY DIVISION  
W A JOHNSON  
DIRECTOR

PLANT MANAGER  
R. C THUMSER

MECHANICAL DEPT.  
J S PUTNAM  
SUPT

RESEARCH SHOPS  
W E WEINER  
SUPT

INSTRUMENT DEPT.  
H. F. FISHER  
SUPT

HEALTH-PHYSICS DEPT.  
K. Z. MORGAN  
SUPT

SECRET

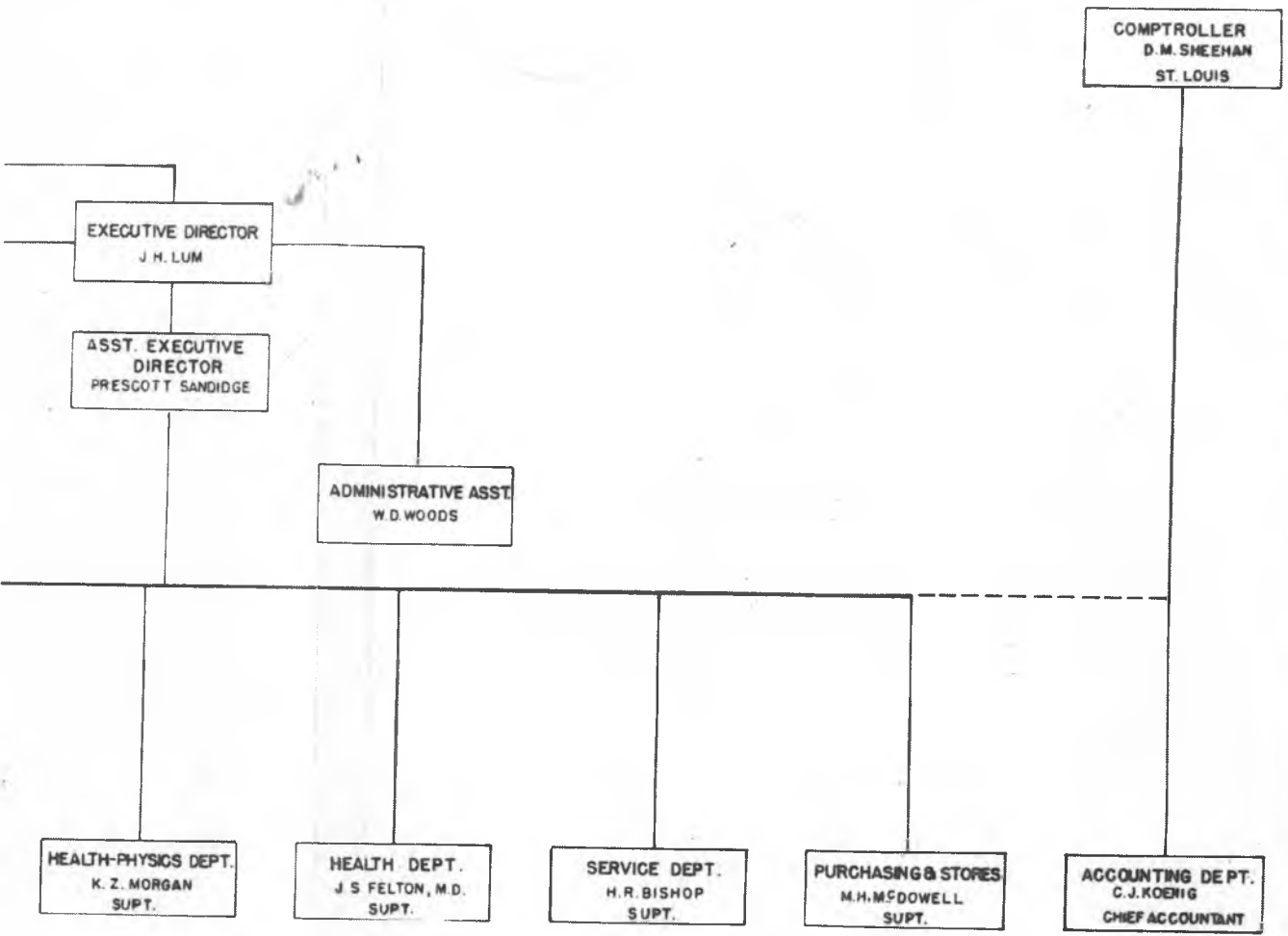

# ORGANIZATION CHART

**MONSANTO CHEMICAL COMPANY**  
 CLINTON LABORATORIES  
 KNOXVILLE, TENNESSEE

D JWA 8-14-46	938 CJAH 8-14-46	A JHR 8-15-46	EPW 8-15-46	B 8-15-46		
------------------	------------------------	------------------	----------------	--------------	--	--

REV. 8-14-46.  
 REV. 11-4-46

## E-1097

B-8

CHEMISTRY DIVISION  
J. R. COE  
DIRECTOR

E. H. TAYLOR  
ASSISTANT DIRECTOR

J. G. STANGBY  
ASSISTANT TO DIRECTOR

GROUP LEADERS  
S. FREED  
J. E. HUDGENS  
G. H. JENKS  
K. A. KRAUS  
H. A. LEVY  
R. LIVINGSTON  
F. T. MILES  
L. T. NEWMAN  
R. T. OVERMAN  
G. W. PARKER  
W. C. PEACOCK  
O. K. RICE  
L. B. ROGERS

GROUP LEADERS  
S. ROSS  
C. H. SEGOY  
E. SHAPIRO  
R. W. STOUGHTON  
J. A. SWARTOUT  
E. R. TOMPKINS  
P. C. TOMPKINS  
W. H. SULLIVAN  
L. R. ZUMWALT

POWER PILE DIVISION  
C. ROGERS MCGULLOUGH  
DIRECTOR

ARGONNE NATIONAL  
LABORATORY  
FARRINGTON DANIELS  
CONSULTANT

ADMINISTRATIVE ASSISTANT  
W. B. DAUME

CONTROL SECTION  
A. TOEFFER  
CHIEF

GAS HANDLING SECTION  
D. STREID  
CHIEF

CHEMICAL PROCESS  
SECTION  
E. B. ASHCRAFT  
CHIEF

DESIGN THEORY  
SECTION  
H. ETHERINGTON  
CHIEF

ORGANIZATION CHARTS  
RESEARCH & DEVELOPMENT DIVISIONS

MONSANTO CHEMICAL COMPANY  
CLINTON LABORATORIES  
KNOXVILLE, TENN.

10-10-54	10/2/54	10/2/54	10/2/54	10/2/54	10/2/54
D. F. HENRY	10/2/54	10/2/54	10/2/54	10/2/54	10/2/54
PROJ. GL. 550	E-1615				
SCALE: NONE					

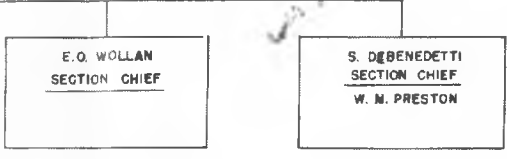

- GROUP LEADERS**
- A. O. ALLEN
  - E. G. BOHLMANN
  - G. J. BORKOWSKI
  - G. E. BOYD
  - M. A. BREDIG
  - A. R. BROSI
  - W. M. BYERLY
  - C. V. CANNON
  - W. E. COHN

R  
IRECTOR

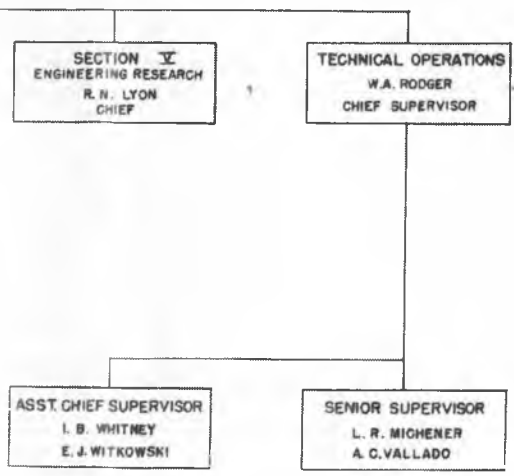

ARGON  
L/  
FARRI  
C

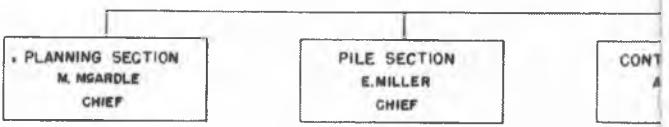

CONT  
A

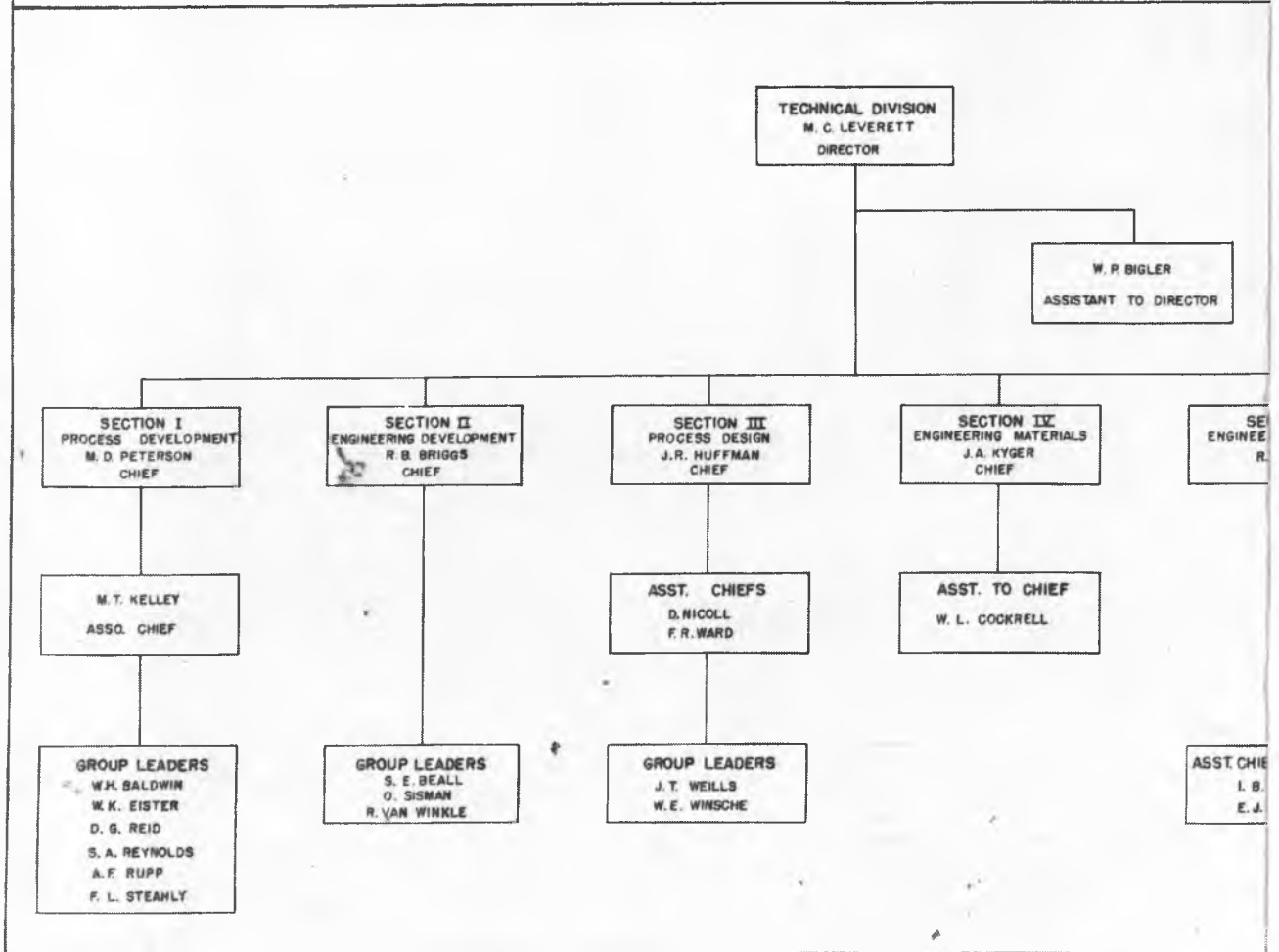
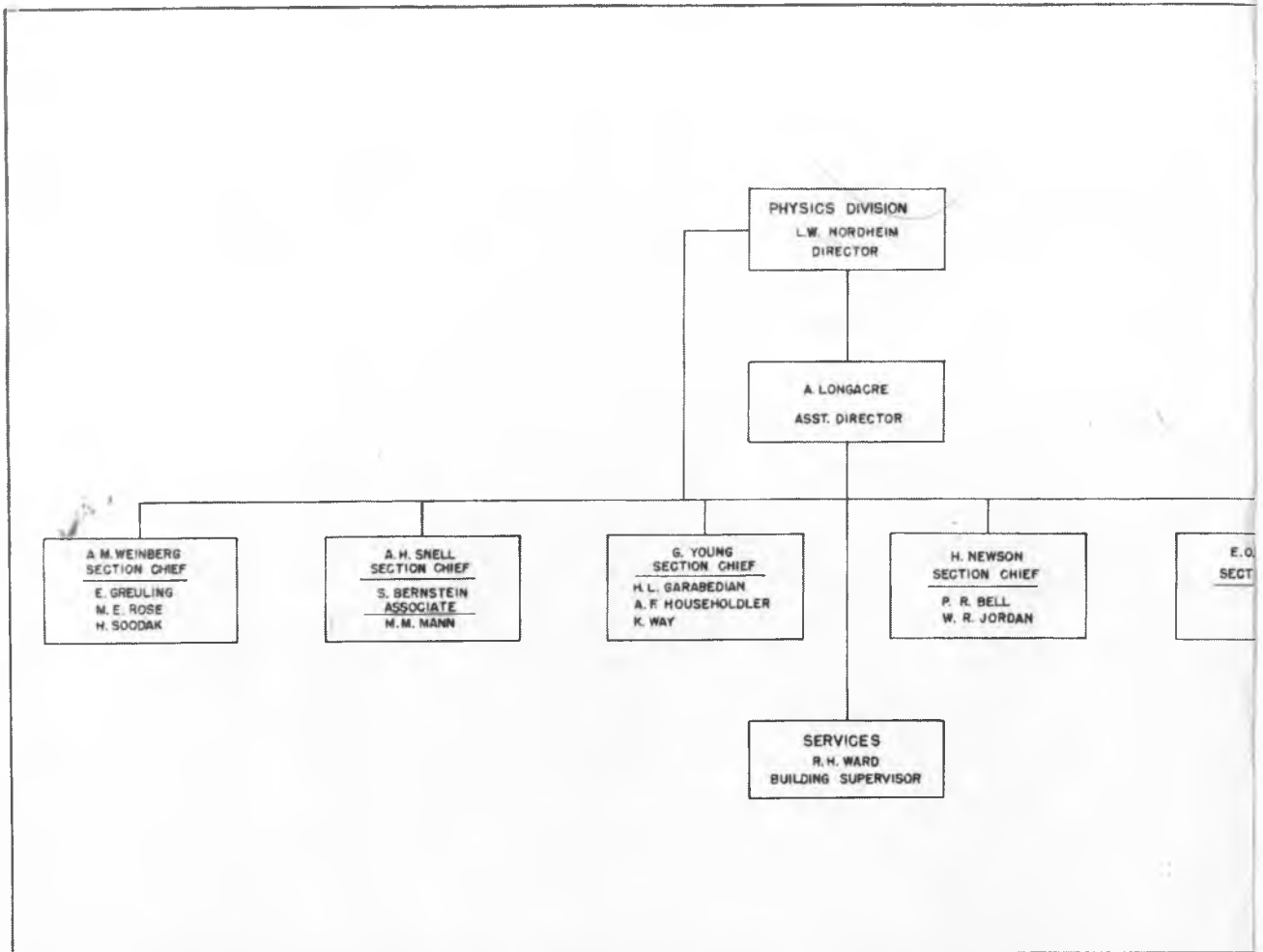



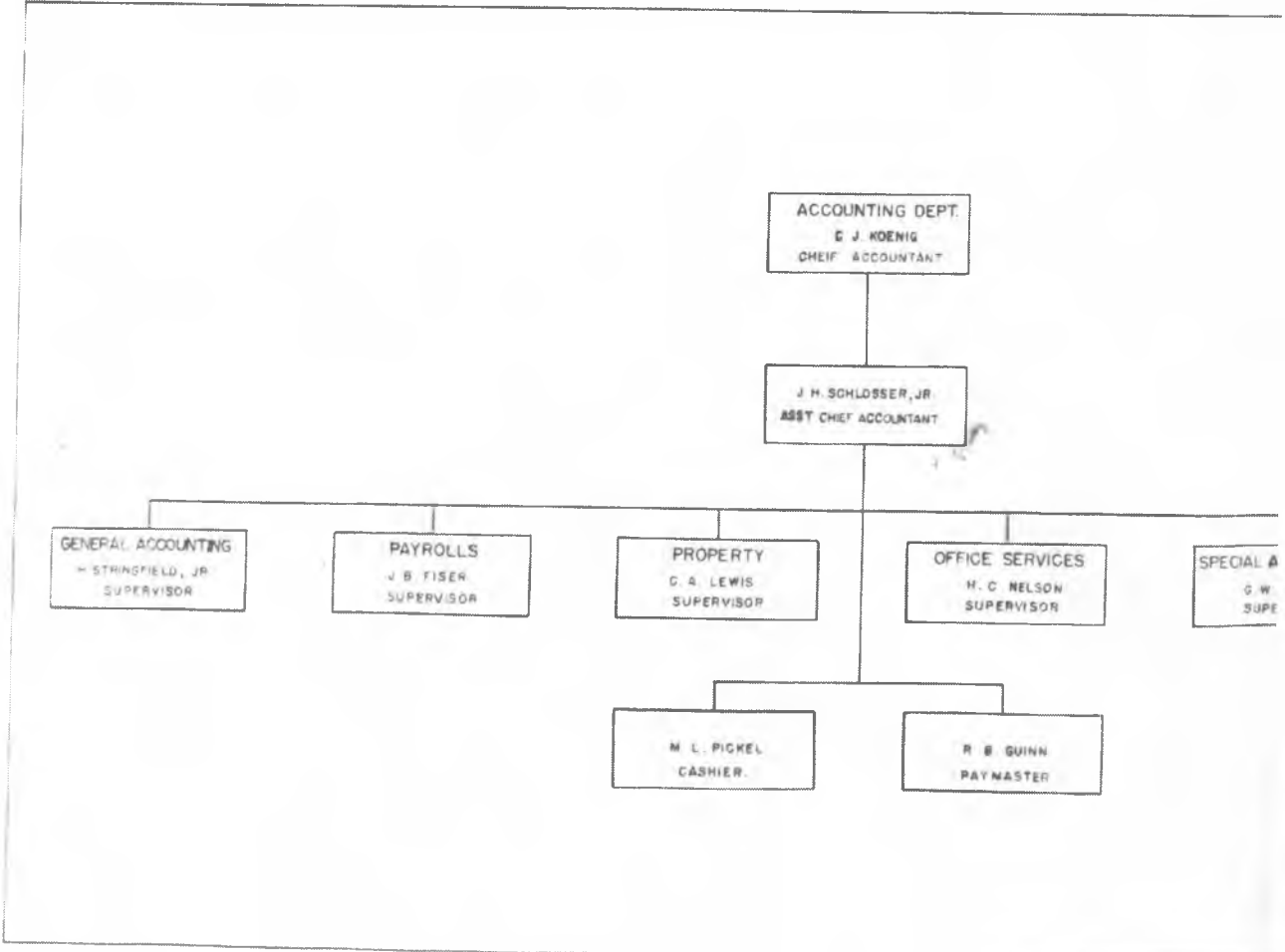
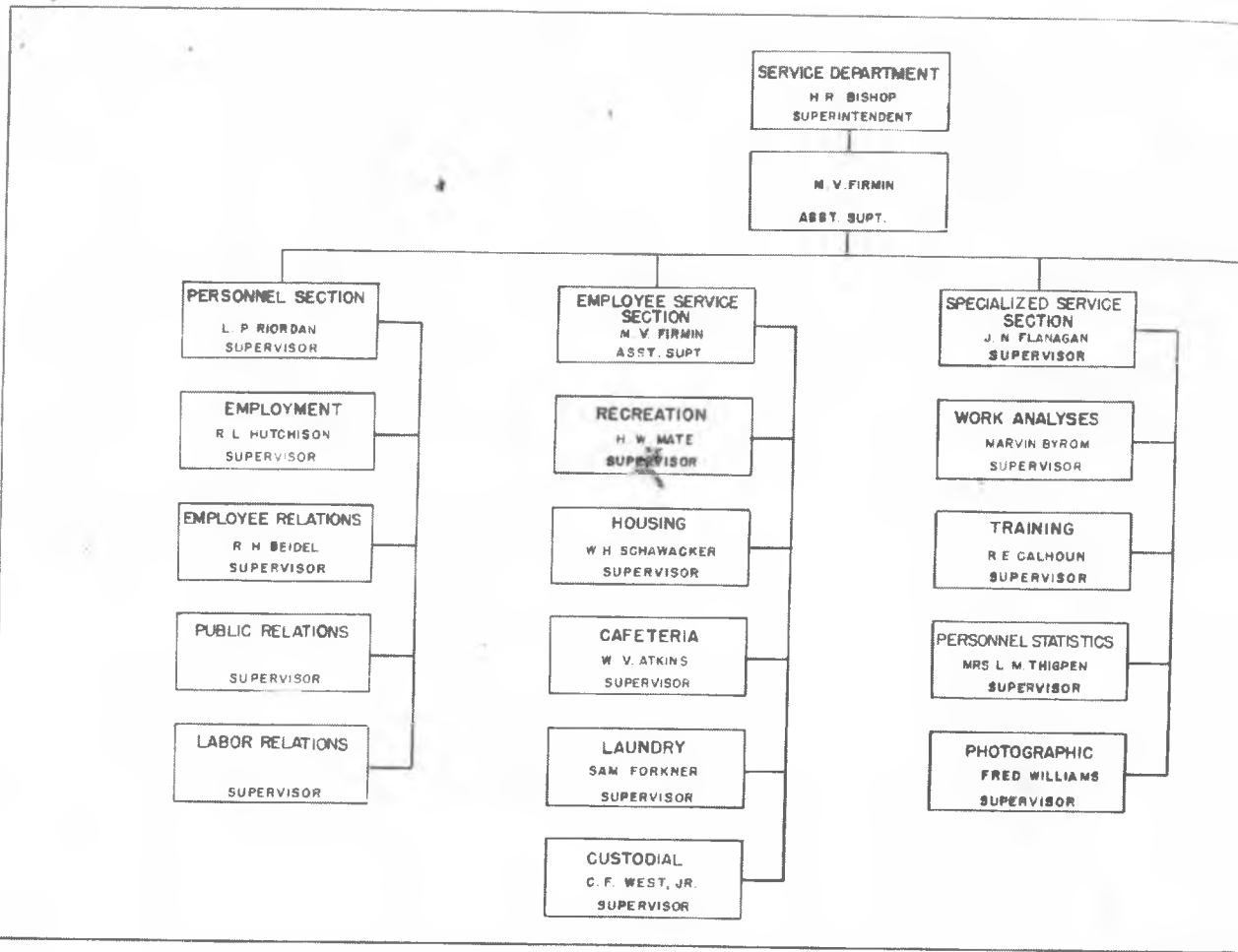

PLANT PROTECTION  
SECTION  
W. A. POPEJOY  
SUPERVISOR

SECURITY-PATROL  
E. R. WOLFE  
SUPERVISOR

FIRE PROTECTION  
D. F. WEBSTER  
FIRE CHIEF

SAFETY  
SUPERVISOR

PURCHASING DEPT.  
R. N. REAMS  
PURCHASING AGENT

TRAFFIC DEPT.  
L. W. COLLINGS  
TRAFFIC MANAGER

BUYERS  
H. K. BLAIR  
W. J. BOYDEN  
R. E. DONAHOE  
A. G. MOTT  
J. E. NICHBERT

CLERICAL  
M. R. SUFFEY  
CLERICAL SUPERVISOR

RATES  
L. LOWE  
CLERK

SPECIAL ASSIGNMENTS  
G. W. TYLER  
SUPERVISOR

ACCOUNTS PAYABLE  
R. S. SNEAD  
SUPERVISOR

DESIGN  
GROUP LEADERS  
J. A. HIGHTOWER  
G. MORRIS  
G. M. PURSWELL  
P. L. ROBERTSON  
K. E. ROSS  
H. A. SELFRIDGE  
J. F. TURNER  
P. L. WEINTRITT

PURCHASING & STORES  
M. H. McDowell  
SUPERINTENDENT

TRAFFIC DEPT.  
L. W. COLLINS  
TRAFFIC MANAGER

STORES & RECEIVING DEPT.  
A. J. COOK  
SUPERVISOR OF STORES

CLERICAL  
J. M. YOUNG  
SUPERVISOR

RECEIVING & SHIPPING  
R. L. DONAHUE  
SUPERVISOR

STORES  
M. B. FLYNN  
SUPERVISOR

AL  
KEY  
RVISOR

RATES  
L. LOWE  
CLERK

W. N. DYKES  
RECEIVING CLERK  
W. A. MEGHEE  
SHIPPING CLERK

STOREKEEPERS  
H. E. BITTLE  
S. C. EVANS  
D. G. GAINES  
C. D. GREENWAY  
I. Z. HUNT  
R. S. PERRIN  
H. S. WHITE

W. E. LAWSON  
INVENTORY CLERK  
L. M. MCGOIB  
SPECIAL ASSIGNMENTS CLERK

PROJECT DEPT.  
W. F. BURGRABE  
SUPERINTENDENT

DESIGN  
GROUP LEADERS  
J. A. HIGHTOWER  
G. MORRIS  
G. M. PURSWELL  
P. L. ROBERTSON  
K. E. ROSS  
H. A. SELFRIDGE  
J. F. TURNER  
P. L. WEINTRITT

ENGINEERS ON SPECIAL  
ASSIGNMENTS  
C. H. MARSH  
R. F. PAHLER

E. G. TIRPAK  
FIELD ENGINEER

ORGANIZATION CHARTS  
ADMINISTRATIVE DEPARTMENTS

MONSANTO CHEMICAL COMPANY  
CLINTON LABORATORIES  
KNOXVILLE, TENN.

5	22-4	10/22/46	17/21	
PROJ. CL 680				2-1617
SCALE NONE				

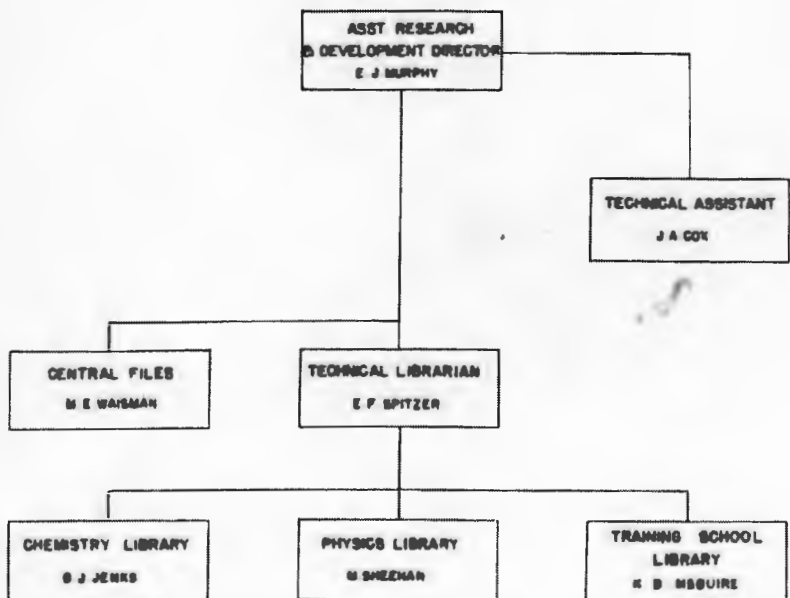
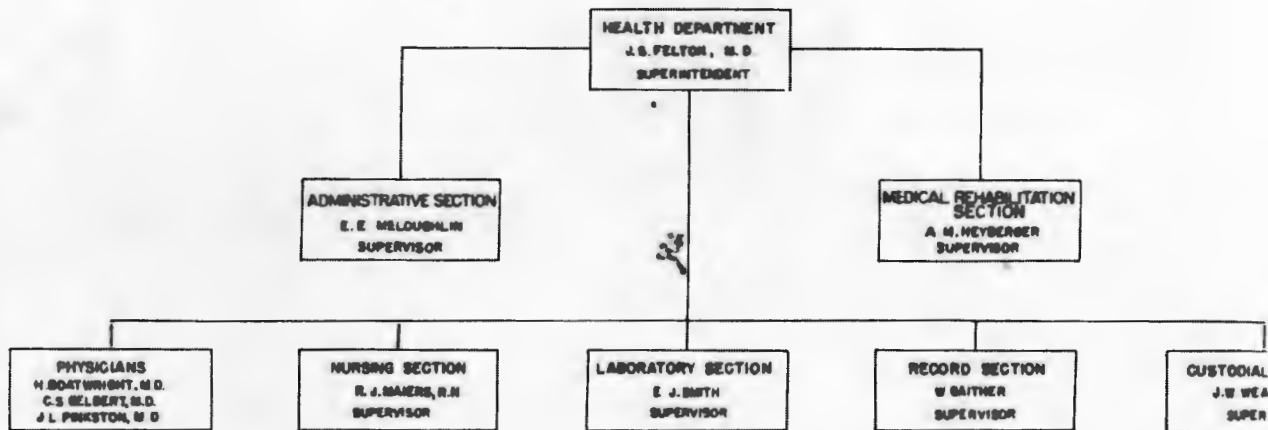

S DEPT.  
AN  
DENT

ADMINISTRATIVE ASSISTANT  
C. E. HAYNES

SURVEY SECTION  
W. H. RAY  
SECTION CHIEF

PERSONNEL MONITORING  
GROUP  
J. C. HART  
SUPERVISOR

SURVEY GROUP  
R. E. HAYDEN  
SUPERVISOR

INSTRUMENT SERVICE  
D. M. DAVIS  
SUPERVISOR

ORGANIZATION CHARTS  
HEALTH & MISC. OTHER DEPTS

MONSANTO CHEMICAL COMPANY  
CLINTON LABORATORIES  
KNOXVILLE, TENN

J.W.A. 8/24/60 J.W.A. 12-2-60  
10-25-60 12-2-60  
PROJ CL 60  
SCALE NONE

E-1618

HEALTH-PHYSIC  
K.Z. MORG  
SUPERINTEN

RESEARCH &  
DEVELOPMENT SECTION  
R.H. FRIMMACH  
SECTION CHIEF

THEORETICAL GROUP  
F. WESTERN  
GROUP LEADER

PHYSICS GROUP  
J.H. ROBERSON  
GROUP LEADER

CHEMISTRY GROUP  
L.B. FARABEE  
GROUP LEADER

CUSTODIAL SECTION  
J.W. WEATHERLY  
SUPERVISOR

APPENDIX C

REFERENCES

Appendix C

MANHATTAN DISTRICT HISTORY

BOOK IV - PILE PROJECT

VOLUME 2 - RESEARCH

PART II - CLINTON LABORATORIES

APPENDIX G

REFERENCES

<u>No.</u>	<u>Description</u>	<u>Location</u>
1.	Contract No. W-7412 eng-23, between the du Pont Company and Manhattan District	District Office Files
2.	Contract No. W-7413 eng-73, between Tennessee Valley Authority and Manhattan District	District Office Files
3.	Contract No. W-7405 eng-59, between University of Chicago and Manhattan District	District Office Files
4.	"Clinton Laboratories Process Manual," Section 3 - "Pile Theory and Operation"	District Office Files
5.	"Physics of the Clinton Pile," 6 March 1944, Report No. CP-1300	District Office Files
6.	Clinton Laboratories Progress Report for the Month of January 1944	District Office Files
7.	"Recommendation for Process Conditions at Hanford Engineer Works and Review of Separation Process Chemistry," 1 October 1944, Report No. CN-2021	District Office Files
8.	"Summary of Experimental Data Pertaining to the Bismuth Phosphate Separations Process, Reported to 1 May 1944," 20 July 1945, Report No. CN-2045	District Office Files
9.	"Product Isolation at Hanford," 17 November 1944, Report No. CN-2051	District Office Files
10.	"Process Design for Waste Metal Recovery," 22 June 1945, Report No. CN-2946	District Office Files



<u>No.</u>	<u>Description</u>	<u>Location</u>
11.	"Disposal of Active Waste Solutions," 15 July 1945, Report No. CP-1852	District Office Files
12.	"Factors Influencing the Carrying of Plutonium by $B_4P_4$ from Uranyl Nitrate Solutions," 30 June 1945, Report No. CP-3103	District Office Files
13.	"Rate of Failure of Defective Plugs," 14 April 1944, Report No. CP-1430	District Office Files
14.	"Corrosion in Pile Water," 22 June 1944, Report No. CP-1644	District Office Files
15.	"Radiation vs. Corrosion: Corrosion Potentials," Report No. CP-1853	District Office Files
16.	"Radiation vs. Corrosion," 7 April 1945, Report No. CP-2918	District Office Files
17.	"Plutonium Project Record, Research and Development Section," Volumes GA and GB - "Coatings and Corrosion"	District Office Files
18.	"The Change in Isotope Abundance in Gadolinium and Samarium by Neutron Absorption," 6 March 1944, Report No. CP-1397	District Office Files
19.	"W Shield Test - Part I - Imperforate Shield Section," 26 January 1944, Report No. CP-1202	District Office Files
20.	"W Shield Test - Part B - Perforate Section," 19 September 1944, Report No. CP-2036	District Office Files
21.	"Radioactivity Induced in Commercial Materials," 26 August 1944, Report No. CP-1351	District Office Files
22.	"The Effect of Radiation on Water and on Aqueous Solutions," 3 May 1944, Report No. CP-1310	District Office Files

APPENDIX D

GLOSSARY

██████████

SARASOTA DISTRICT HISTORY

BOOK IV - FILE PROJECT

VOLUME 2 - GENERAL

PART II - CLINTON LABORATORIES

APPENDIX D

GLOSSARY

Adsorption Column. - An adsorption column is a tube or pipe, packed with an adsorbent, through which a solution is passed with the desired portion of the solution being adsorbed on the adsorbent.

Digestion. - Digestion is the term applied to the treatment of a precipitate, in this case, under heat and agitation, to produce a more uniform precipitate.

Foils. - Foils are thin strips of metal that are inserted into openings in the shield to determine the radiation level in the Pipe or in the shield. The foils are then checked with a Geiger counter and the activity determined.

Geiger Counter. - The Geiger counter is a sensitive instrument for detecting ionizing radiations. It "counts" any ionizing radiation regardless of its nature.

Lattice Dimension Experiments. - Experiments to determine the effect of various uranium-graphite spacings on file reactivity are termed lattice dimension experiments.

Styrene. - A synthetic rubberlike plastic formed by the polymerization of chloroprene.

Neutron Flux. - The neutron flux is the rate of flow of neutrons across

[REDACTED]

or through a surface.

Precipitator. - A precipitator is a vessel in which a substance in solution is converted into the solid state by the action of a chemical reagent or reagents. The vessel is equipped with an agitator to insure intimate mixing of the reagents.

Thermal Shield. - The thermal shield is a shield composed of cast iron blocks, which surrounds the graphite in the Pile and absorbs heat, neutrons, and beta particles produced in the Pile.

Index

INDEX

- Ackart, E. G., 8.1  
Administration Bldg., 2.6  
Adsorption  
    Columns, 5.8  
    Processes, 5.1, 5.7ff.  
Agitators, 6.4  
Air Lines, 2.6  
Alternate Separation Processes,  
    5.2  
    Development of, 5.7ff.  
Aluminum, 4.4, 4.7, 6.2ff., 6.7  
    Jackets, 4.7ff., 6.2ff.  
    Arc-Welded, 4.8, 6.2ff.  
    Tests to Detect Failure of,  
    6.1ff.  
Animal Cages, 4.4  
Antimony, 4.10  
Area Shop Bldg., 2.4  
Authorization, 1.2
- Bakelite, 6.7  
Barium, 4.10  
Bernard Free Skin & Cancer  
    Hospital, 5.10  
Barracks, 2.8  
Beta Activity, 6.7  
Bismuth Phosphate, 5.1  
    Process, 5.7ff.  
Boron Steel  
    Rods, 4.6  
    Shot, 4.6  
Brass, 6.7
- Cafeteria, 2.6  
Canal, 2.4, 4.7  
Can Failure, Detection of, 6.1ff.  
Cancer, 5.10  
Cantril, Dr. S. T., 8.2  
Carbon 14, 5.10  
Carbide & Carbon, 7.3  
Carriers, 5.1, 5.4, 5.6  
Catch Tank, 5.3  
Cells, 5.2ff., 5.7  
Centrifuge, 5.3  
Cerium, 5.4  
Charging  
    Machines, 4.7  
    Tubes, 4.2ff., 4.5  
Chemical Processing Plant, 2.4,  
    5.1ff.  
Chemistry Laboratory Bldg., 2.6  
Chestnut Ridge, 1.2  
Chicago, Ill., 4.10, 8.1  
Chief Accountant, 8.2  
Classified Construction, 2.3,  
    2.7ff.  
Clinton Engineer Works, 1.2, 3.1,  
    3.3  
Clinton Laboratories, 1.1ff.,  
    2.1ff., 3.1ff., 4.1ff., 5.1ff.,  
    6.1, 6.5, 7.1ff., 8.1ff.  
    Construction of, 2.1ff.  
    Design of, 2.1ff.  
    Director, 8.2  
    Location, 1.2  
    Operation of, 2.1, 3.1ff.  
    Organization, 8.1ff.  
    Personnel, 3.5, 8.2ff.  
Clinton Pile, 5.10, 6.5, 6.7  
Clinton, Tenn., 1.2, 2.6  
Closures, 4.4  
Columbia River, 6.3ff., 6.7  
Communication Facilities, 2.5  
Completion of Work, 4.10, 5.7  
Compton, A. H., 8.2  
Concrete, 2.7, 4.3, 4.5, 5.3,  
    6.7  
    Haydite-Barytes, 4.3, 4.5  
    Precast Blocks, 4.3  
    Ready-Mixed, 2.7  
    Shielding, 4.3, 4.5, 5.3  
    Construction, 2.1ff.  
    Contractor, 2.1, 2.3ff.  
    Contractual Arrangements, 2.2  
    Cost of, 2.10  
    Delays, 2.7ff.  
    Division (du Pont), 8.1  
    of General Service Facilities,  
    2.5ff.  
    of Pile Facilities, 2.3ff.  
    of Process Area Service  
    Facilities, 2.6  
    of Separation Facilities, 2.4  
    of Training Facilities, 2.4ff.

Cone, W.A., 2.9

Contract  
 No. W-31-109 eng-39, 2.9  
 No. W-35-058 eng-71, 3.5ff.  
 No. W-7405 eng-39, 2.1, 3.2, 3.5ff.  
 No. W-7412 eng-23, 2.1ff.  
 Contracting Officer, 3.3  
 Contractual Arrangements, 2.2, 3.2  
 Change Over, 3.5  
 Construction, 2.2  
 Design, 2.2  
 Operation, 3.2ff.  
 Control Panels  
 Pile, 4.6  
 Separation Process, 5.3  
 Control Rods, 4.2, 4.6, 4.8  
 Calibration, 4.8  
 Control Room, 5.3  
 Controls, Pile, 4.6  
 Cooling System, 4.5, 4.8ff.  
 Efficiency of, 4.8  
 Corps of Engineers, 8.3  
 Costs  
 Construction, 2.10  
 Design, 2.10  
 Emergency additions, 2.10  
 Operation, 3.6  
 Cowdry, Dr. E.V., 5.10  
 Crushed Stone, 2.7

Daniels, H. T., 8.1  
 Davidson, John, 2.9  
 Deaeration, 6.7  
 Decontamination Factor, 5.4  
 Deflection Test, 6.2ff.  
 Delays, Construction, 2.7ff.  
 Design, 2.1ff.  
 Cost of, 2.10  
 Design Div. (du Pont), 2.3, 8.1  
 Design Problems (Hanford), 6.1ff.  
 Discharge Pit, 4.7  
 Dissolver, 5.3  
 Distribution Program, 5.9  
 District Engineer's Office, 8.3  
 Contract Sec., 8.3  
 Priorities Sec., 8.3  
 Selective Service Sec., 8.3  
 Doan, R. L., 8.2  
 Drainage and Waste Systems, 5.3  
 Drainage Ditches, 2.6

Drinking Water, 2.5ff.  
 Ducts, 4.5  
 Du Pont, E. I., de Nemours and Co., Inc., 2.1ff., 3.1, 4.1, 6.1ff., 7.1ff., 8.1  
 Construction Div., 2.3, 8.1  
 Design Div., 2.3, 8.1  
 Employees, 7.1ff.  
 Field Office, 2.7  
 Purchasing Dept., 2.7  
 Wilmington Office, 2.3, 2.7

Elevator, 4.6  
 Exhauster Bldg., 2.4

Fan  
 Bearing Troubles, 4.9  
 Failure, 4.9  
 Mouse, 4.5  
 Fans, 4.2, 4.5, 4.9  
 Fences, 2.6  
 Field Office (du Pont), 2.7  
 Field Project Manager, 8.1  
 Filters, 4.5  
 Fire Stations, 2.6  
 First Aid Facilities, 2.6  
 First War Powers Act, 3.2  
 Fission, Nuclear, 5.9  
 Fission, Process of, 5.8, 6.5  
 Fission Products, 2.2, 4.1, 5.1, 5.4ff., 5.7ff., 6.4ff.  
 Studies of, 5.8ff.  
 Foils, 4.4, 6.6  
 Fort Loudon Hydroelectric Plant, 2.5  
 Furniture, Office, 2.7

Gadolinium, 6.5  
 Gamma Radiation, 4.5, 6.6ff.  
 Gary, T. C., 8.1  
 Gaseous Wastes, 5.3  
 Gasoline, 2.7  
 Geiger Counters, 6.7  
 Government, United States, 2.1, 2.3, 3.2ff.  
 Grafton, Capt. J. F., 8.3  
 Graphite, 4.2, 4.7, 6.7  
 Blocks, 4.2, 4.7  
 Matrix, 4.2

Greager, O.H., 8.2  
Groves, L.R., Maj. Gen., 1.2  
Guard Towers, 2.6

Hanford Engineer Works, 1.1, 2.1,  
2.3ff, 3.1, 3.3ff, 4.10, 5.1ff.,  
5.4ff., 5.7, 6.1, 6.5ff., 7.1ff.,  
8.3  
Harriman, Tenn., 1.2  
Haw Ridge, 1.2  
Maydite-Barytes Concrete, 4.3, 4.5  
Health Division, 8.2  
Health Program, 3.4  
Helium, 4.1  
Hoist, 4.7  
Holabird and Root, 2.9  
Horizontal Storage Trench, 4.7  
"Hot" Laboratory Bldg., 2.6  
Housing, 2.8, 3.5  
Hydroelectric Plants, 2.5  
Fort Loudon, 2.5  
Morris, 2.5  
Watts Bar, 2.5  
Hydrogen Peroxide, 6.7

Instrument Storage Bldg., 2.4  
Intelligence and Security Program,  
3.4ff.  
Interruptions of Operation, 4.9  
Ionization Chambers, 4.4, 6.6  
Irwin, W., 8.1  
Isolation Process, 1.1, 3.4, 5.5ff,  
Development of, 5.5ff.  
Recommendations for, 5.6  
Isotopes, 5.10

Johnson, W.C., 8.2  
Jones, J.A., Construction Co.,  
2.9, 2.10

Kay, W.C., 8.2  
Kellex Corp., 2.9

Laboratories, Chemical, 2.2, 2.6  
Laboratory Expansion, 5.10  
Labor  
Relations Board, 3.5  
Shortages, 2.3, 2.8  
Turnover, 2.3, 2.8

Lanthanum, 4.10, 5.5ff  
Fluoride, 5.1  
Lattice Arrangement, 4.8  
Lattice Dimension Experiments,  
4.3  
Laundry, 2.6  
Layne Central Co., 2.5  
Lehigh University, 8.2  
Lenoir City, Tenn., 1.2  
Loading Method, 4.8  
Location, 1.2  
Los Alamos, N.M., 4.10  
Lum, Dr. J.H., 8.2

Machine Shop, 2.6  
Mackie, F. H., 8.1  
Manhattan District, 1.2, 2.1ff.,  
3.4ff., 4.10  
Intelligence and Security  
Program, 3.4ff.  
Labor Policies, 3.5  
Project, 1.2, 4.10  
Safety Ratings, 3.4  
Martel, J.P., 8.1  
Masonite, 6.6ff.  
Mattress Pads, 4.7  
Memphis, Tenn., 2.5  
Metal Channels, 4.2ff.  
Metallurgical Laboratory, 1.1,  
2.1ff., 3.1, 5.1ff., 5.9,  
6.2, 6.5, 8.1ff.  
Director, 2.1  
Military Policy Committee, 1.2, 2.1  
Mock-Up Unit, 7.1  
Monitoring, 7.2  
Monorail Crane, 4.7  
Monsanto Chemical Co., 2.9, 3.5,  
7.1ff, 8.2  
Murphy, Maj. E. J., 8.3

NEPA, 7.3  
Negotiation of Contract  
Design and Construction, 2.1  
Operation, 3.2  
Neoprene, 6.7  
Neutralizer, 5.3  
Neutron Flux, 4.8  
Neutrons, 4.5, 6.4  
Norris Hydroelectric Plant, 2.5  
Nuclear Fission, 5.9  
Nuclear Science, 7.1ff.



Oak Ridge, Tenn., 1.2, 2.8, 3.1,  
     3.4  
 Objectives, 1.1  
 Oil, 2:7  
 Operating Contractor, 2.3ff., 2.7ff.,  
     3.1ff.  
     Performance of, 3.3ff.  
     Selection of, 3.1ff.  
 Operating Power Level, 4.7ff.  
 Operating Problems (Hanford), 6.1ff.  
 Operation of Clinton Laboratories,  
     2.1, 3.1ff.  
     Appropriation for, 3.3  
     Cost of, 3.6  
 Organization, 8.1ff.  
     Corps of Engineers, 8.3  
     Design and Construction, 8.1  
     Operation, 8.1ff.  
 OSRD, 1.2, 3.1  
     S-1 Committee, 1.2  
  
 Pardee, F. W., Jr., 8.1  
 Parking Lot, 2.6  
 Patent Rights, 2.3, 3.3  
 Patrol Headquarters, 2.6  
 Performance  
     of Construction Contractor,  
         2.3ff.  
     of Operating Contractor, 3.3ff.  
 Personnel, 3.5, 3.2ff.  
 Photographic Plates, 6.6  
 Physics Laboratory Bldg., 2.6  
 Pile, 1.1, 2.2, 2.4, 4.1ff., 5.8,  
     6.1ff.  
     Area, 2.4, 2.10  
     Construction of, 2.3ff.  
     Building, 2.4  
     Controls, 4.6  
     Cooling System, 4.5  
     Description of, 4.2  
     Graphite Matrix, 4.2ff.  
     Openings, 4.2, 4.4  
     Operating Level, 4.7ff.  
     Poisoning, 6.1, 6.4ff.  
     Project, 1.2, 3.1  
     Removable Core, 4.2, 4.4  
     Shielding, 4.3ff.  
     Slug Handling Facilities, 4.6ff.  
     Start-Up, 4.7ff.  
 Piles (Hanford), 4.1, 6.1ff., 6.5ff.  
     Shielding, 6.1, 6.5ff.  
  
     Test of Materials for, 6.7  
 Pilot Plant, 1.1, 3.1, 3.3,  
     4.1, 5.2ff., 5.7, 7.1  
 Piping, 5.3  
 Plant Manager, 3.2  
 Plugs, 4.2, 4.8  
 Plutonium, 1.1, 2.1, 3.2,  
     3.4, 4.1, 4.6, 5.1ff, 6.1,  
     6.4, 7.1  
     Development of Process for  
         Separation of, 5.1ff.  
     Fluoride, 5.1  
     Nitrate, 5.6  
     Peroxide, 5.6  
     Phosphate, 5.1  
     Production, 4.1  
         Completion of Work, 4.10  
     Plants, 2.1ff., 3.1, 4.1,  
         5.1, 6.1  
         Rate, 4.1, 4.8ff.  
         Schedule, 3.4, 4.7, 4.9  
         Yields, 5.4, 5.7  
     Studies of Chemistry of,  
         5.9  
 Poisoning, 6.1, 6.4ff.  
 Power, Calibration, 4.8  
 Power Facilities, 2.5  
 Power Output, 4.2, 4.7ff.  
 Pratt, S. W., 3.2  
 Precipitation Processes, 5.1,  
     5.8  
 Precipitator, 5.3  
 President of the United  
     States, 1.2, 3.2  
 Prime Contractor (construc-  
     tion), 2.7ff.; See also,  
     du Pont  
 Process of Fission, 5.3, 6.5  
 Process Wastes, 5.3, 5.6  
 Procurement, 2.7  
     by du Pont Co., 2.7  
     by Government, 2.7  
     of Isotopes, 5.10  
 Production  
     of Plutonium, 4.1ff.  
     Superintendent, 3.2  
     Unit, 3.4, 4.1ff.  
     Yields, 5.4, 5.7  
 Purchase Orders, 2.7  
 Purchasing Dept. (du Pont),  
     2.7

Radiation, 4.2, 4.4ff., 5.3, 6.1,  
6.4, 6.6ff.

Radioactive Materials, 2.6, 4.10,

Radio Isotope Building, 2.9

Radioisotopes, 5.9, 5.10

Rainfall, 2.3, 2.6ff.

Read, W. M., 8.1

Regulating Rods, 4.4, 4.6

Removable Core, 4.3ff.

Reports, 5.5ff.

Research, 1.1ff., 3.1ff., 4.10,  
5.3ff.

Associate Director of, 8.2

Biological, 1.1, 3.3ff.

Chemical, 1.2, 3.4, 5.8ff.

Medical, 1.1, 3.3ff.

Physical, 1.1, 3.4

Retention Ponds, 5.3

Roads, 2.6

Reane County, Tenn., 1.2

Rubber Tubing, 6.7

## Safety

Program, 3.4

Rods, 4.2, 4.4, 4.6

Tubes, 4.6

Samarium, 6.5

Scanning Mechanism, 4.4

Scavengers, 5.4

Schwartzfeger, A. J., 8.2

Scope, 1.1ff.

Seitz, Dr. Frederick, 7.3

Semi-Works, 5.2, 5.4

## Separation

Area, 2.4, 2.10

Construction of, 2.4

Building, 2.4, 4.7, 6.2ff.,  
5.6ff.

Plant, 5.5ff.

Process, 1.1, 3.4, 5.1ff.

Completion of work, 5.7

Development of, 5.1ff.

Pilot Plant, 5.2, 5.4

Recommendations for, 5.4ff.

Semi-Works, 5.2, 5.4

Septic System, 2.6

Service Facilities, 2.5ff.

General, 2.5ff.

Process Area, 2.6

Service Superintendent, 8.2

Sewage System, 2.5ff.

Shielding, 4.2ff., 6.3, 6.5,  
6.8

Biological, 6.6

Cell, 5.3

Pile, 4.2ff.

Test of, 6.6ff.

Thermal, 6.6

Shim Rods, 4.4, 4.6

Slugs, 4.2, 4.6ff., 5.2, 5.7,  
6.1ff.

Aluminum-Silicon Bonded, 6.4

Canning, 6.1ff.

Corrosion, 6.3ff.

Detection of Swelling, 6.1ff.

Handling Facilities, 4.6ff.

Testing, 6.2ff.

Smith, D. M., 8.2

Solution Tanks, 5.4

Solvent Extraction Processes,

6.1

Southern Bell Telephone Co.,

2.5

Special Engineer Detachment,

8.3

Stack, 4.2, 4.5, 5.3

Activity, 4.8

Stainless Steel

Bucket, 4.7

Chute, 4.7

Steam System, 2.5ff.

Subcontractors, 2.3

Subcontracts, 2.6ff.

Telephone Service, 2.5

Teletype Service, 2.5

Temperature Coefficient, 4.8

Tennessee, State of, 3.2

Tennessee Eastman, 7.3

Tennessee Valley Authority,

2.5

Tires, 2.7

Title of Property, 2.3, 3.3

Construction, 2.3

Operation, 3.3

Training Area, 2.4, 2.10,

7.1ff.

Construction of, 2.4

Cost, 2.10

Disposal of Equipment, 7.3