

The image shows a black Energizer HOMEPOWER HP-6M (Main Unit) and HP-6S (Sub Unit) power supply system. The main unit is a large, vertical, black rectangular box with a silver horizontal band across the middle. The sub unit is a smaller, black rectangular box positioned to the right of the main unit. The background is dark, and the units are illuminated from the sides, creating a sleek, modern appearance. The Energizer logo is visible on the main unit, and the HOMEPOWER logo is at the top.

Energizer[®]

HOMEPOWER

Energizer

OWNER'S MANUAL

HP-6M (Main Unit) ***HP-6S*** (Sub Unit)

Disclaimer

For the latest *Energizer* Homepower documents, visit energizerhomepower.com

© 2021 Energizer. Energizer and certain graphic designs are trademarks of Energizer Brands, LLC and related subsidiaries and are used under license by 8 Star Energy Pty Ltd.

All other brand names are trademarks of their respective owners. Neither 8 Star Energy Pty Ltd nor Energizer Brands, LLC is affiliated with the respective owners of their trademarks.

To secure the full 10-year Product Warranty, *Energizer* Homepower HP-6 Series must be commissioned using the *Energizer* Homepower Installer App and system must stay connected to the *Energizer* Homepower Cloud.

Warning: Read this entire document before installing or using the *Energizer* Homepower (HP-6M/HP-6S). Failure to do so or to follow any of the instructions or warnings in this document can result in electrical shock, serious injury, or death, or can damage the product, potentially rendering it inoperable.

Environmental Protection

Electronic device: Do not throw away. Electrical products should not be disposed of with household waste. Proper disposal of batteries is required. Refer to your local codes for disposal requirements.



Copyright © 2021 Energizer. All rights reserved.

Contact Information

Energizer Homepower
Level 1,
12 Risle Street,
Richmond VIC 3121
Australia
+61 (03) 9110 1000
energizerhomepower.com
support@energizerhomepower.com

Table of Contents

1. Important Safety Instructions	4
2. Product Overview (<i>Energizer</i> Homepower HP-6 Series)	8
Electrical Specifications	12
Standard Operation	13
Edge Lighting	13
Monitoring your system	15
Internet connection	16
3. Maintenance	18
Troubleshooting System faults	18
Step 1 - System Reboot	18
Step 2 - Shut Down Sequence (HP-6M/HP-6S)	20
Step 3 - Power On Sequence (HP-6M/HP-6S)	21
Step 4 - Technical Resolutions	21
4. Emergency Procedures	22
5. First Aid Measures	23
6. Safety Datasheet	24
7. Limited Warranty	33
8. I&C Checklist	37

1. Important Safety Instructions

This Owner's Manual contains essential instructions that must be followed during operation and maintenance of the *Energizer* Homepower HP-6 Series BESS (Battery Energy Storage System). To ensure safe installation and operation, the *Energizer* Homepower HP-6 Series should only be installed by certified *Energizer* Homepower Installers. Please note the following safety symbols that appear throughout this document that indicate dangerous conditions, relevant warnings, and notes to facilitate best results.

Symbol Used



DANGER: This indicates a hazardous situation, which if not avoided, could result in death or serious injury.



WARNING: This indicates a situation where failure to follow instructions may be a safety hazard or cause equipment malfunction. Use extreme caution and follow instructions carefully.



NOTE: This indicates an important step that leads to best results but is not safety or damage related.



REFER TO OPERATING INSTRUCTIONS: This indicates that the user should refer to operating or installation instructions before proceeding.



HOT SURFACE: This indicates that the surface may be hot, please beware.



CAUTION, RISK OF ELECTRIC SHOCK, ENERGY STORAGE TIMED DISCHARGE: Discharge time is 5 minutes from de-energization.



EARTH: This indicates location of grounding point on the equipment.



LOCKING POINT: This indicates location of locking point on the equipment.



EUROPEAN CONFORMITY: This indicates that the product conforms to standards within the European Union.



RCM: This indicates that the product is marked with the Regulatory Compliance Mark in accordance with the requirements listed within the independent schemes.



SAA: This indicates that the product is certified by SAA Approvals and conforms to standards in regard to compliance with legal requirements for manufacturing and selling electrical products within Australasia.



TUV SUD: This indicates that the product has been tested and certified by TUV SUD.

All installations must comply with local and national electrical standards. Read the entire document before installing or using the *Energizer* Homepower HP-6 Series. Failure to follow any instructions or warnings in this document may result in electrical shock, serious injury, and death or may damage the battery, potentially rendering it inoperable. Failure to follow any instructions or warnings may void the Warranty.

Dangers



Energizer Homepower HP-6 Series system installations must be carried out only by *Energizer* Homepower Certified Installers, who have been trained to work with Low Voltage electricity, while using Personal Protective Equipment (PPE) to handle the battery.



The *Energizer* Homepower HP-6 Series units are heavy objects, use of PPE and lift equipment is recommended.



Do not use the *Energizer* Homepower HP-6 Series units if they are defective, appear cracked, broken, or damaged in any sense.



A damaged *Energizer* Homepower HP-6 Series unit can present a real risk of fire, electric shock, and discomfort from vented gases. Observe necessary precautions.



Do not allow or place tools, metal parts or flammable/explosive items near the *Energizer* Homepower HP-6 Series units.



Do not attempt to open, disassemble, repair or tamper with the *Energizer* Homepower HP-6 Series units, as doing so may result in damage to equipment and/or cause injury or death. Contact the *Energizer* Homepower authorised reseller for any repairs.



Always de-energise the AC branch circuit during an emergency and/or before servicing the *Energizer* Homepower HP-6 Series system. Never disconnect the DC connectors under load.



Energizer Homepower HP-6 Series units can present a risk of high short-circuit current. Observe the following precautions when operating the system:

- Remove watches, rings, or other metal objects.
- Use tools with insulated handles.
- Wear rubber gloves and boots.



When placing *Energizer* Homepower HP-6 Series units in storage, ensure that the battery isolator is switched off.

Warnings



During usage, always keep the *Energizer* Homepower HP-6 Series units in an upright position. Do not impact, pull, drag, step, or apply strong force on the *Energizer* Homepower HP-6 Series units.



To help prevent damage, leave the *Energizer* Homepower HP-6 Series units in their original shipping packaging, until they are ready to be installed.



Ensure the *Energizer* Homepower HP-6 Series system is installed only on a suitable wall, using the wall-mount bracket included.



Do not use solvents and/or cleaning fluids to clean the *Energizer* Homepower HP-6 Series units or expose them to harsh chemicals or vapours.



Do not use any third-party accessories, fluids, or paint to alter the internal or external components including the exterior casing.



Do not sit on, step on, place objects on or insert objects into *Energizer* Homepower HP-6 Series units. Please refrain from placing liquids or containers (with liquids) on top of the *Energizer* Homepower HP-6 Series units.



Damage to the *Energizer* Homepower HP-6 Series units can occur from over-discharge. While in storage, it is expected to discharge gradually. Ensure that the *Energizer* Homepower HP-6 Series units are installed by the “Must Energize by Date” located on the packaging.



If an *Energizer* Homepower HP-6 Series unit needs to be replaced or removed, it must be turned off as per the recommended shutdown procedure prior to removal.



Ensure the absence of any water sources above or near *Energizer* Homepower HP-6 Series units, including sprinklers, water jets, garden hoses or faucets.



If the *Energizer* Homepower HP-6 Series units are being installed in a garage or near moving vehicles, it is recommended to install the unit clear of the driving path and provide necessary protection in the form of bollards.

Definitions

- SoC** - State of Charge.
CT's - Current Transformer Sensors.
BMS - Battery Management System.
Generation - Refers to the electrical energy produced by your solar system.
Consumption - Refers to the electrical energy used within your household.

2. Product Overview (Energizer Homepower HP-6 Series)

The *Energizer Homepower HP-6 Series* is an AC coupled, lithium iron phosphate based Battery Energy Storage System (BESS), designed to operate seamlessly with existing solar (PV) installations. It is easy to install and allows a high degree of customisation to suit a variety of energy considerations. The *Energizer Homepower HP-6 Series* is modular and consists of the Main Unit (HP-6M) and up to 3 optional Sub Units (HP-6S).

The *Energizer Homepower HP-6 Series* measures solar generation & energy consumption using its generation and consumption CTs, and then utilises its intelligent algorithms to either charge or discharge its batteries to reduce consumption from the grid and increase local energy usage. This improves overall energy efficiency by aiding local consumption of solar energy and reducing feed-in/export to the utility grid.

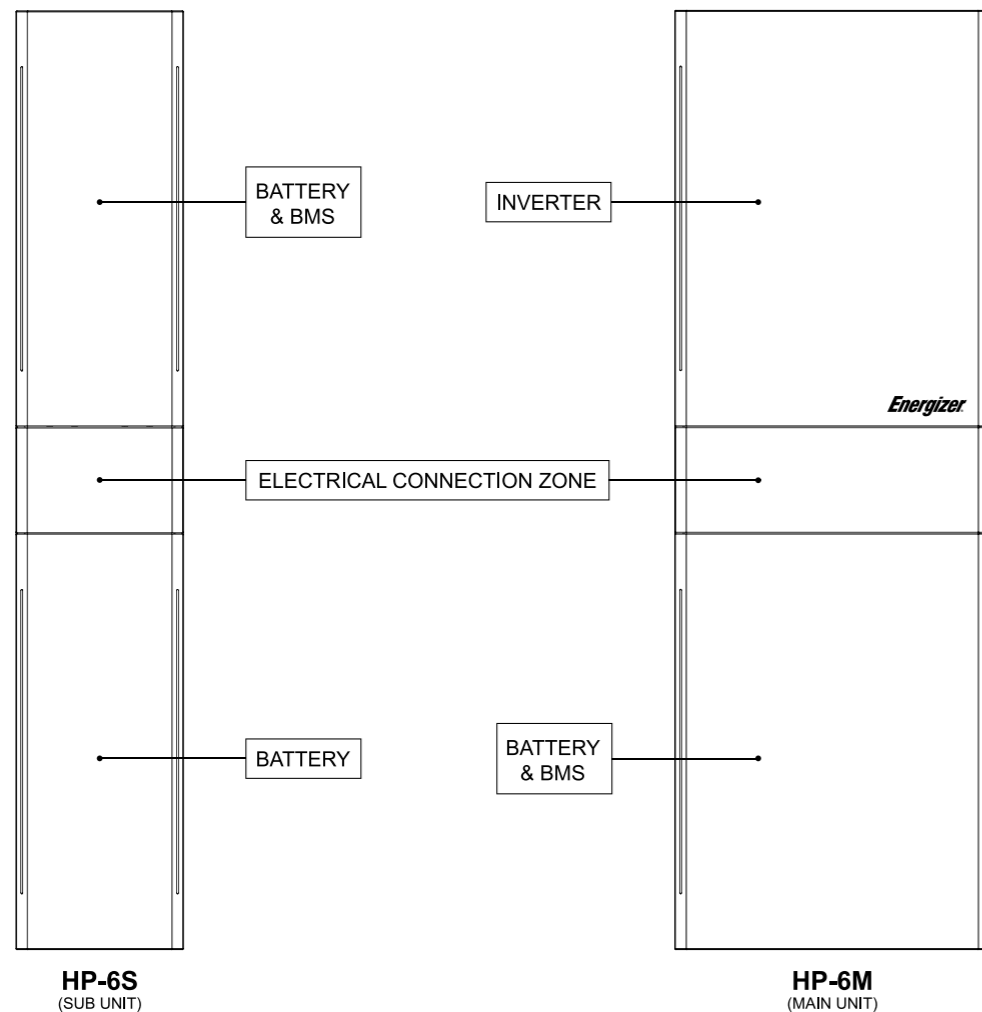

Fig. 1. *Energizer Homepower HP-6M & HP-6S Units*

The *Energizer Homepower HP-6 Series* system can operate in 3 unique application modes: **Automatic**, **Semi-Automatic** and **Manual**. Each mode follows a unique priority and can be customised to operate as per site requirements.

1. **Automatic Mode** - is the default mode of operation. The system determines the energy supply requirement with the priority: **Site Loads > Battery Charge > Grid Export > Battery Discharge > Grid Import**.

The operating sequence is as follows:

- a. Solar generation supplies the connected loads.
- b. When site loads are lower than solar generation, excess solar energy is diverted towards battery charging.
- c. When site loads are lower than solar generation and battery is full (SoC 100%), the excess solar generation is exported to the utility grid.
- d. When site loads are greater than solar generation (or at night time), energy is primarily discharged from the battery to supply the loads.
- e. When the site loads are greater than the sum of solar generation and battery output, the balance is drawn from the utility grid.

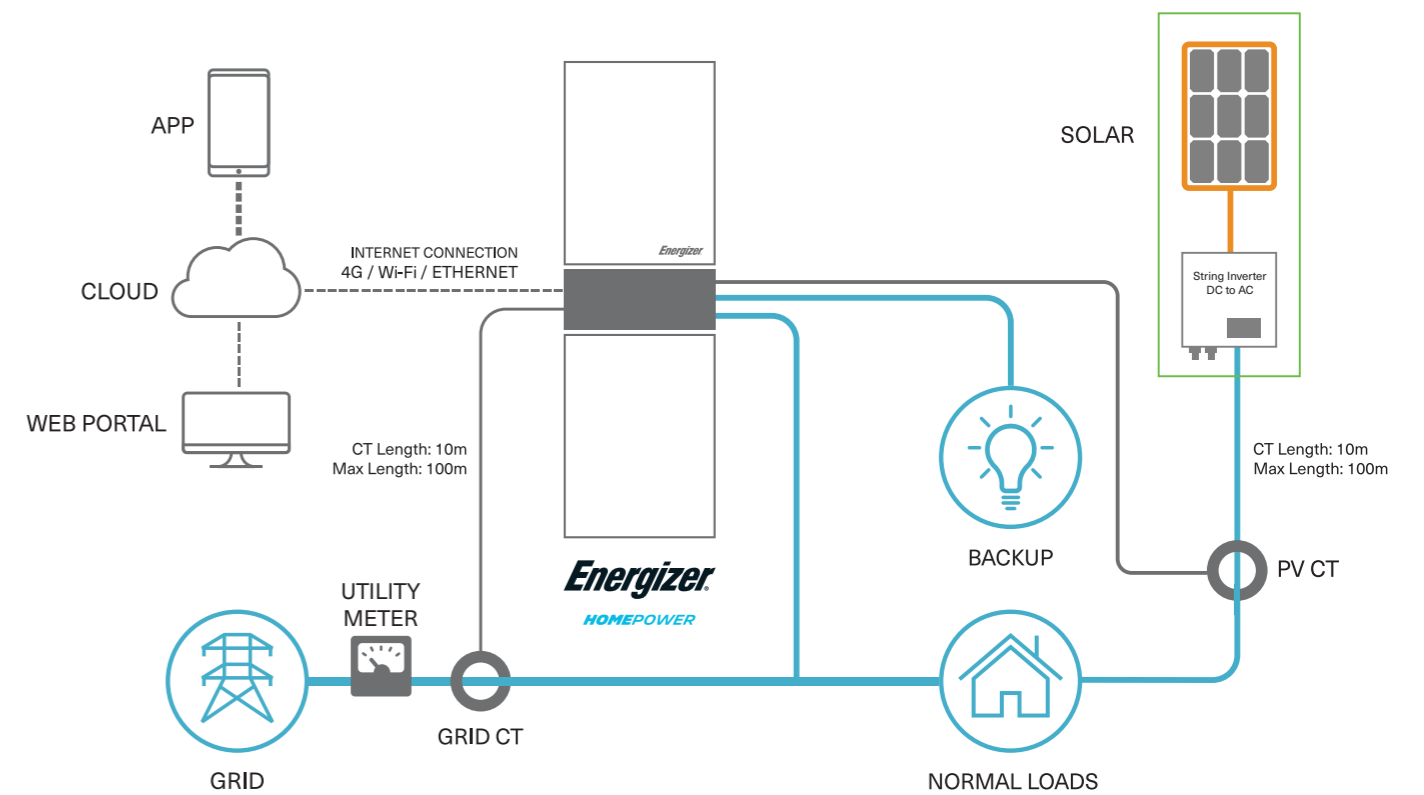

Fig. 2. *Energizer Homepower HP-6 Series System Map*

- 2. Semi-Automatic Mode** - is an optional mode. The system allows for a certain percentage of the solar generation to be reserved towards battery charging and/or export to grid. The system determines the energy supply requirement with the priority: **Site Loads > Battery Charge (& Grid Export) > Grid Export > Battery Discharge > Grid Import**. The operating sequence is as follows:
- Solar generation is mainly utilised to supply the connected loads.
 - When site loads are lower than solar generation, excess solar energy is divided between battery charging and/or export to utility grid. E.g. if PV Charge % is set to 70%, then 70% of solar generation is used to charge the battery, whereas the remaining 30% is exported to the utility grid.
 - When site loads are lower than solar generation and battery is full (SoC 100%), the excess solar generation is exported to the utility grid.
 - When site loads are greater than solar generation (or at night time), energy is primarily discharged from the battery to supply these loads.
 - When the site loads are greater than both solar generation and/or battery discharge combined, the balance is drawn from the utility grid.
- 3. Manual Mode** - is also an optional mode. The system allows for electricity tariff arbitrage by customising battery charge and discharge functions. The battery can be charged on-demand using either solar or utility grid energy and can be discharged on-demand towards site loads. The entire schedule can be configured on *Energizer Homepower Cloud*.

3.1. Maximum State of Charge - This setting is found on the Application Mode window within customer app/portal. It limits the maximum SOC capacity that the grid can charge the battery to. E.g. If set to 80%, then the grid can be used to charge until SOC hits 80%. Above this SOC level, the grid will not be used to charge the battery.

3.2. Blank windows of time - When there are no instructions for the Scheduler entered for a window of time then the unit will revert to Automatic Mode until it reaches a window of time with instructions.

- a. Automatic mode logic:**
Site Loads > Battery Charge > Grid Export > Battery Discharge > Grid Import.

3.3. Percentages - Within the Scheduler, you will need to input a percentage for the instruction you want the Plant to follow.

- a. This value is the percentage of the maximum inverter capacity (3600W).** E.g. For grid charge, if you input 60% then only 2160W (~60% of 3600W) will be used to charge the battery from the grid.

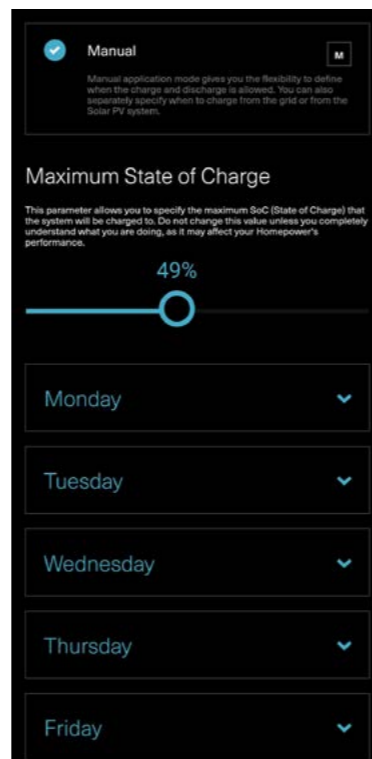

Fig. 3. Homepower Scheduler

- 3.4. Grid Charge** - Specifies when to use the grid to charge the battery. If left unticked, *Energizer Homepower* will not charge from the grid.
- E.g. 20% @ 5am - 7am** - Following this instruction, the battery will charge from the grid at 720W between the times of 5am and 7am.



When used: Designate when to charge the battery, normally during off peak periods. This allows customers to reduce the need to consume grid power during peak periods.

- 3.5. PV Charge** - Limits the amount of solar generation used to charge the battery (e.g. 50% @ 10am - 12pm).
- E.g. 50% @ 10am - 12pm** - With these instructions, during 5pm - 9pm, only 2160W will be available for use from the battery. If any additional power is required, it will be drawn from the grid.



When used: Generally used to exempt scheduled periods of time from using the battery or ensure availability of battery power by minimising consumption throughout the day. E.g. When heat pumps are scheduled to be on during off peak periods.

- 3.6. Discharge to loads** - Restricts how much energy is drawn from the battery during times when site loads are greater than solar generation. Usually, early mornings and in the evenings.
- E.g. 60% @ 5pm - 9pm** - With these instructions, during 5pm - 9pm, only 2160W will be available for use from the battery. If any additional power is required, it will be drawn from the grid.



When used: Generally used to exempt scheduled periods of time from using the battery or ensure availability of battery power by minimising consumption throughout the day. E.g. When heat pumps are scheduled to be on during off peak periods.

Electrical Specifications

The *Energizer* Homepower HP-6 Series system can intelligently control the charge and discharge based on several parameters including connected loads, solar generation, and external environmental conditions. It is sensitive to the temperature variations & may limit charge or discharge based on internal cell temperature. Therefore, it is recommended to avoid installations in locations that may be directly exposed to sunlight for prolonged periods of time, and/or locations with sustained high or low temperatures. The *Energizer* Homepower HP-6 Series units are designed to operate optimally in an average ambient temperature range between 0 °C to 30 °C.

Homepower Series	HP-6M	HP-6M/1S	HP-6M/2S	HP-6M/3S	HP-6S ³
Rated Energy ¹ (kWh)	6.14	12.28	18.42	24.56	6.14
Usable Capacity ² (kWh)	5.8	11.6	17.4	23.2	5.8
Dimensions (H/W/D; mm)	1244/420/183	1244/646/183	1244/872/183	1244/1098/183	1244/222/183
Weight (kg):	98.5	168.5	238.5	308.5	70.0
Ingress Protection	IP65				
OTR ⁴ (Operating Temperature Range)	Charge: 0 to 45 °C, Discharge: -20 to 50 °C				
Recommended OTR	0 to 30 °C				
Protection Class	Class I				
Operating Altitude Range	<2000 m				
Operating Humidity (RH)	0 - 95%				
Mains Connection	Single-phase, L/N/PE				
Inverter					
Nominal Output Voltage (V)	230 V a.c.				
Nominal AC Frequency (Hz)	50 Hz (Self-Adapting)				
PF Range	1 (adj 0.8 leading - 0.8 lagging)				
Nominal Power (W)	3600 W				
Nominal AC Current (A)	16 A				
Cooling	Natural Convection				
¹ Rated Energy is determined as per battery standard IEC 62619:2017.					
² Usable Capacity is calculated as 95% of Rated Energy.					
³ HP-6S unit is considered a sub-system of the Main Unit (HP-6M) and is never installed in a stand-alone manner.					
⁴ Performance de-rating expected in extreme ambient temperature.					

Table 1. Technical Specifications (HP-6 Series)

Homepower Series	HP-6M	HP-6M/1S	HP-6M/2S	HP-6M/3S	HP-6S
Battery					
Battery Type	LFP (Lithium Iron Phosphate)				
Rated Capacity ⁵	120 Ah	240 Ah	360 Ah	480 Ah	120 Ah
Nominal Voltage	51.2 V d.c.				
Max Current	71 A d.c.(charge/discharge)				
Additional Features					
Supported Communication Interfaces	2.4G Wi-Fi, Ethernet, Cellular/4G (to Cloud)				
Monitoring	<i>Energizer</i> Homepower Monitoring (App & Web platform)				
⁵ Rated Capacity is determined as per battery standard IEC 62619:2017.					

Table 1. Technical Specifications (HP-6 Series)

Standard Operation

The *Energizer* Homepower HP-6 Series system is designed for both indoor & outdoor installations and can be monitored using a variety of interfaces including Edge Lighting, an LCD panel, the *Energizer* Homepower App and Customer Portal.

Edge Lighting

The Edge Lighting is designed to convey at-a-glance information about system operating states such as Normal, Stand-by and Fault.

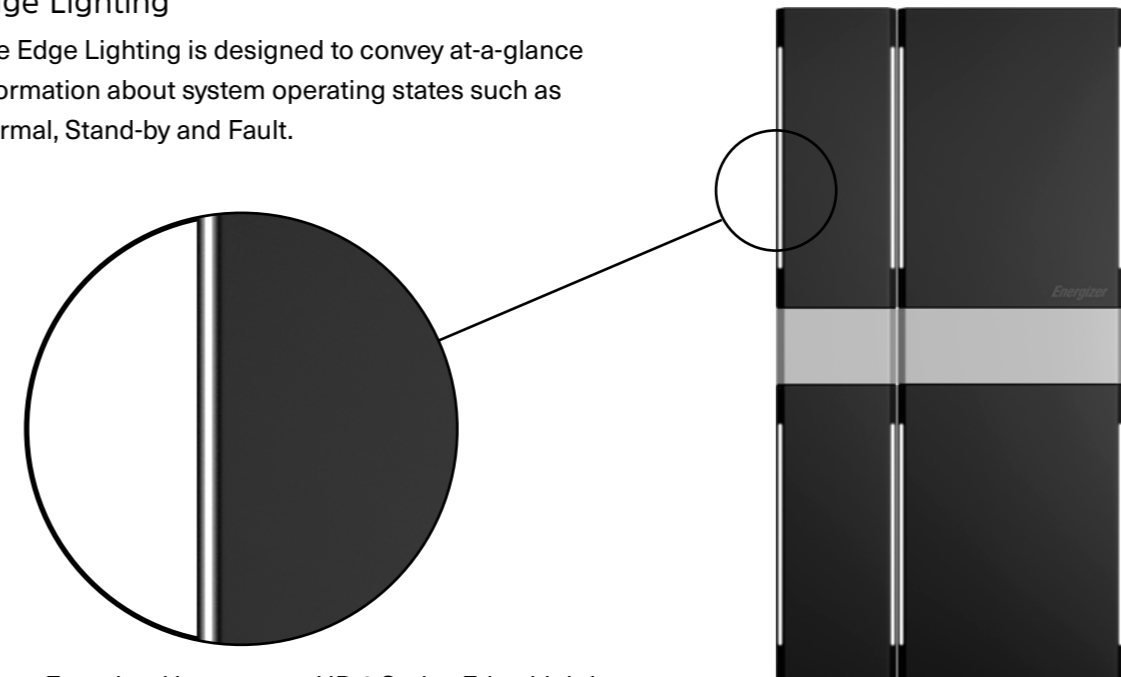
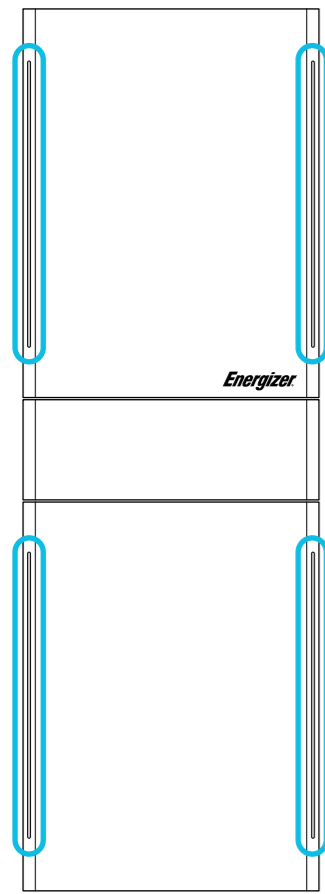

Fig. 4. *Energizer* Homepower HP-6 Series Edge Lighting



Operating State	Sequence	Description
Normal		The Edge Lighting mimics a breathing function when the system is charging, discharging or in stand-by. The brightness varies between 20-80%.
Fault		Fault is indicated by a sequence of 3 flashes (duration 0.5s). repeating every 8s.
Low SoC (State of Charge)	<p>10% > SoC > 5%</p>	When the system is in Standby mode and SoC is between 5% and 10%, there is a flash (duration 0.2s) every 2 mins.
	SoC < 5% OFF	When the system is in Standby mode and SoC is lower than 5%, the edge lighting remains off to conserve energy.

Table 2. Edge Lighting Sequence - Explanation

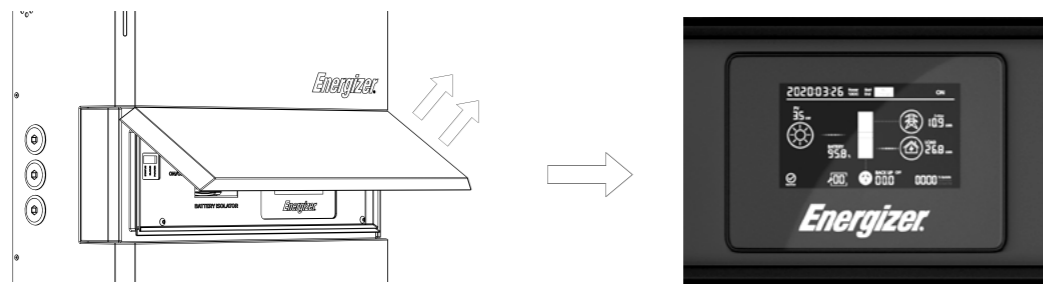

Fig. 5. HP-6M Installer Access Panel & LCD Panel

Owners can also access the LCD panel by raising the HP-6M's Magna-Flap. The display provides real-time information of solar generation, energy consumption from house and backup (UPS) loads, feed-in (export) and battery State-of-Charge (SoC).

Monitoring your system

You can monitor your *Energizer Homepower HP-6 Series* system using the *Energizer Homepower App* or *Customer Portal* to provide an overview of the system, including SoC, real-time/historical energy consumption and solar generation amongst many other useful features. The latest version of the App & Customer Portal can be accessed at energizerhomepower.com.

The *Energizer Homepower HP-6 Series* uses an integrated communications module that supports 2.4G Wi-Fi, 4G (LTE) and/or Ethernet for internet connectivity and communication with the *Energizer Homepower Cloud*. It is essential to connect the HP-6 Series system to the *Energizer Homepower Cloud* to enable real-time monitoring and remote device troubleshooting. When selecting the method of communication, it is recommended to follow the order of preference where available:



- The HP-6M supports only one method of communication at any one time, ensure that an appropriate method is selected (either 4G/LTE, Wi-Fi, or Ethernet) depending on the site conditions.
- In areas or regions with weak 4G/LTE signal, CAT-5E cables (or Ethernet) can be used to connect the HP-6 system to a Wi-Fi router.

Internet Connection

In the event your *Energizer* Homepower gets disconnected from the internet, you shall be notified by email. You will also find a notification within the *Energizer* Homepower App and within the Customer Portal that the internet is disconnected.



If connection is via Ethernet (data cable from router to unit) then please check the connection of the cables on the router to make sure it is plugged in correctly. If you are unable to get your system to reconnect, please contact your reseller.



If your unit is usually connected via 4G and has lost connection, please contact your reseller.



Disconnection is most common in Wi-Fi configurations due to network or password changes or the router being placed in a new location that is out of the systems range. If the router has been moved, try moving it closer to the *Energizer* Homepower unit and wait a few minutes to see if the system picks up the signal. If the network name or password has been changed, please follow the steps below to help reconfigure the connection.

This process can be done through a smart phone, tablet or computer, and the steps are the same no matter which device you choose use to reconnect your *Energizer* Homepower to the internet.

Step 1. Tap on the menu button, select “Settings”.

Step 2. Tap on the “Network Configuration” option to change network settings, the app will pull the current configuration and status of the unit if using the iOS app.

Step 3. On the next screen you will be able to change your connection settings by tapping on “Change Connection Settings”.

Step 4. Tap on “Connect Via Bluetooth”, ensuring you are within 3 metres of the unit. Your phone will scan for your Energizer Homepower Unit. Select your device and tap “Next”.

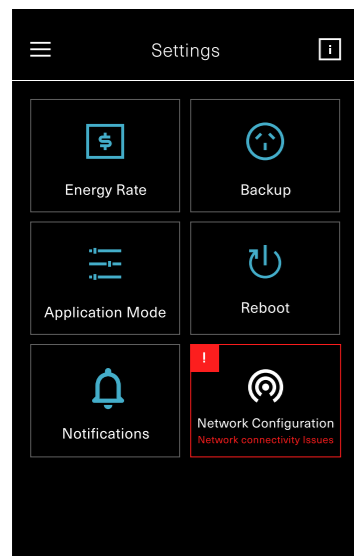

Fig. 6. Network Issue



Fig. 7. Connect to Homepower

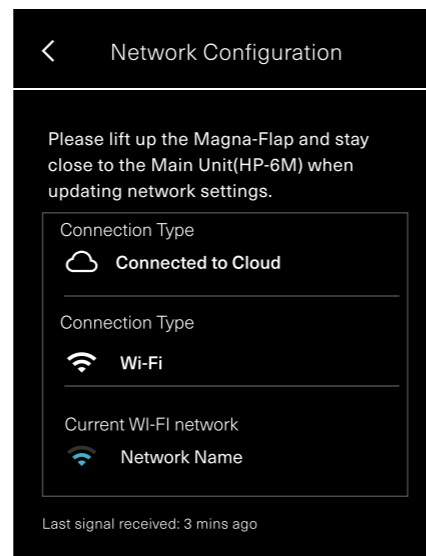

Fig. 8. Connection Status

Step 5. Once connected, tap on “Change Connection Settings”. If selecting Wi-Fi, tick the Wi-Fi box and tap “Next”.



Note: in this screen you can change the connection type to 4G, Ethernet and Wi-Fi. (Failover and priority options also available).

Step 6. Local networks will appear, select your Wi-Fi network, select your network and tap “Connect”.



Note: a warning will pop up if a weak network is selected, signal strength must be higher than 2 bars, if it's not, you may need to install an extender or opt for ethernet connection.

Step 7. Enter the network password and tap “Continue”.

Step 8. You will receive a prompt confirming your Energizer Homepower is attempting to reconnect to the network.

Step 9. Wait a few minutes and the network error icons will disappear and Net Status will change to “Online”.

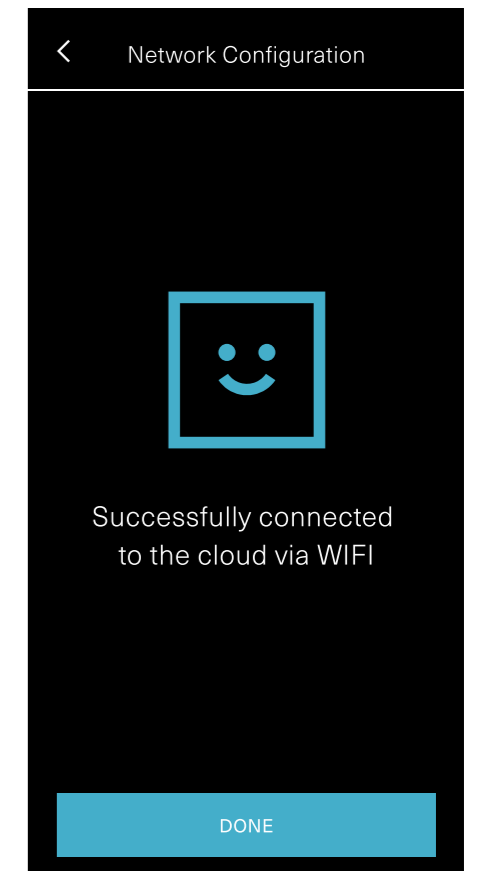
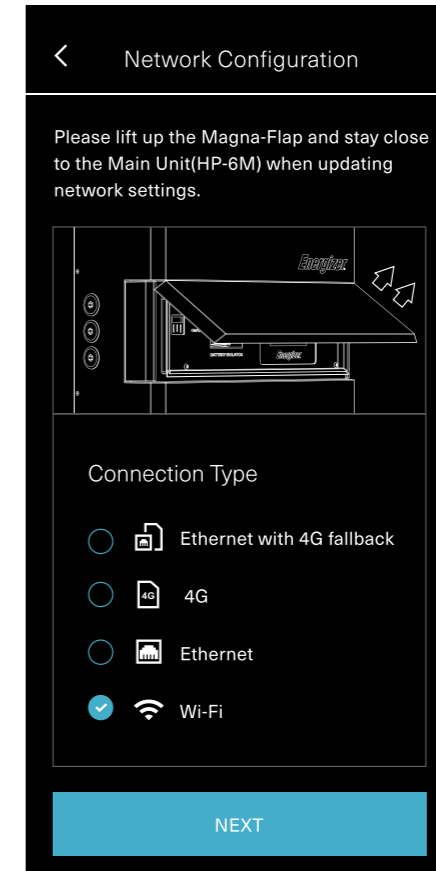
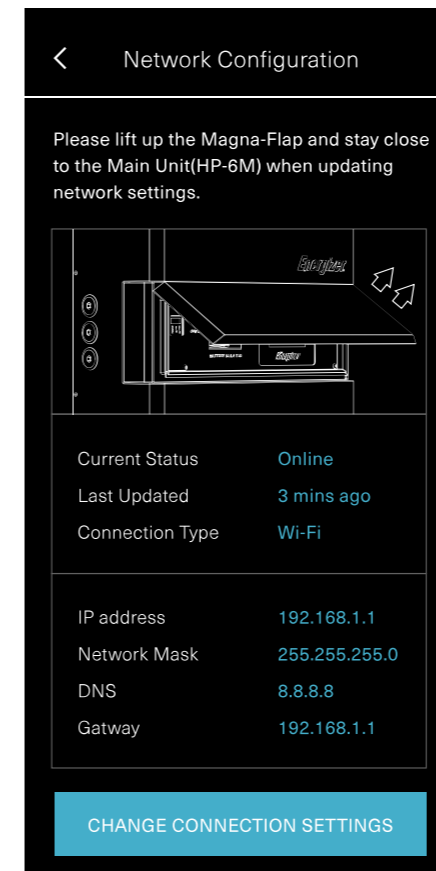

Fig. 9. Change Connection Settings

3. Maintenance

The *Energizer Homepower HP-6 Series* does not require any routine maintenance from the end user. For accumulation of dirt, dust, or debris, please ensure the product frame is cleaned using a soft dry cloth. The *Energizer Homepower HP-6M* has vents located on the top, left and right-hand side of the unit for natural convection, and these must be kept free of objects and/or obstructions.

Do not use any third-party accessories, fluids, or paint to alter the internal or external components including the exterior casing.

Troubleshooting System faults

When normal system operation is interrupted, the Edge Lighting will display the respective operating state i.e., fault, as described in Table 2 (on page 13). If this is the case, refer to the *Energizer Homepower App* or *Customer Portal* to identify the system issue and resolve fault.

If you are unable to view the system using the *Energizer Homepower App* or *Customer Portal*, ensure the system is connected to the internet and contact your system provider.

If you have experienced a blackout during operation, the loads connected on the Backup side must be reduced and Circuit Breakers must be checked (for trips) within the switchboard.

Step 1 - System Reboot

If you are unable to resolve the system fault(s) via the *Energizer Homepower App*, then you may be required to reboot the unit in consultation with your system provider. In this case, navigate within the *Energizer Homepower App* to Settings and select Reboot as shown below:

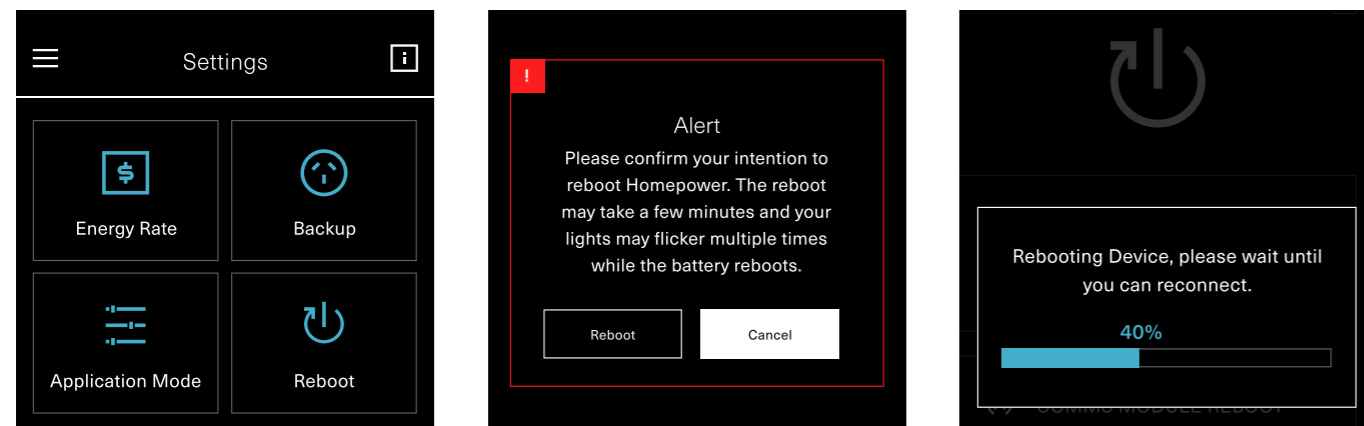

Fig. 10. System Reboot (*Energizer Homepower App*)

The system reboot function shall then appear with a Status Bar, indicating when the operation is complete.



Incorrect operation may damage the *Energizer Homepower HP-6 Series* system. Do not reboot the device without specific instructions or technical advice from your system provider.

If you are using the *Energizer Homepower Customer Portal*, the same operation can be performed here. You would first need to login to your account at portal.energizerhomepower.com, navigate to Settings and select Reboot. The function shall then appear with a Status Bar, indicating when the operation is complete.

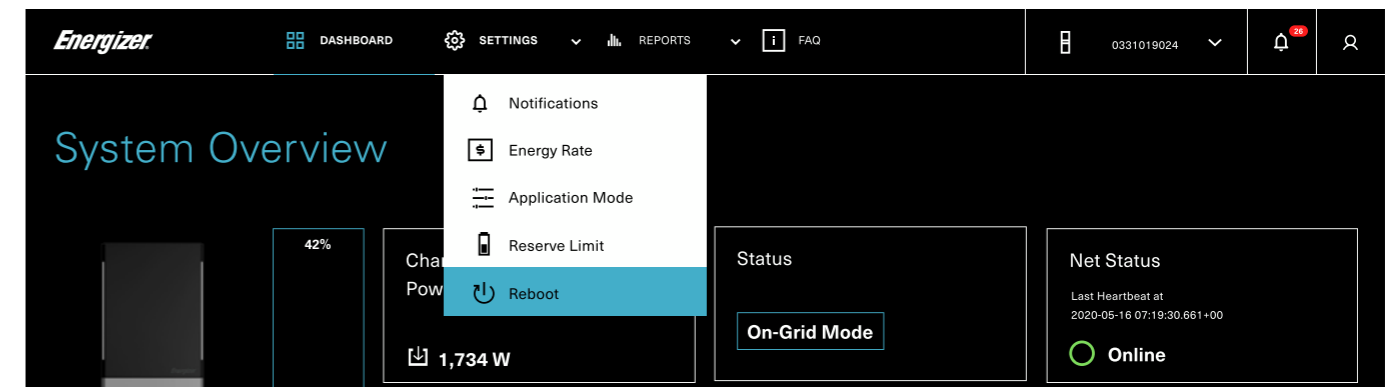

Fig. 11. System Reboot (*Customer Portal*)

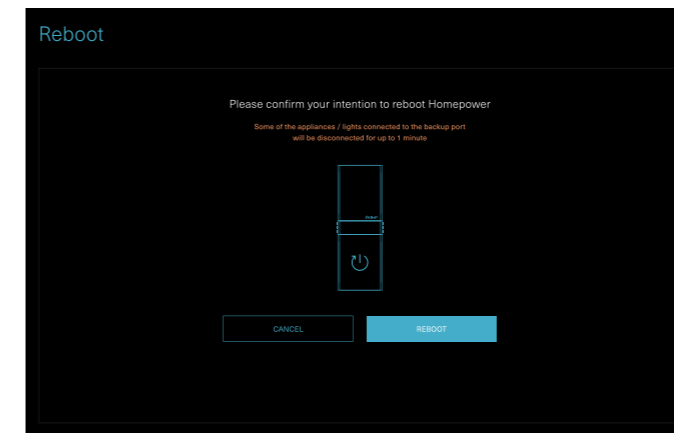

Fig. 12. System Reboot (*Customer Portal*)

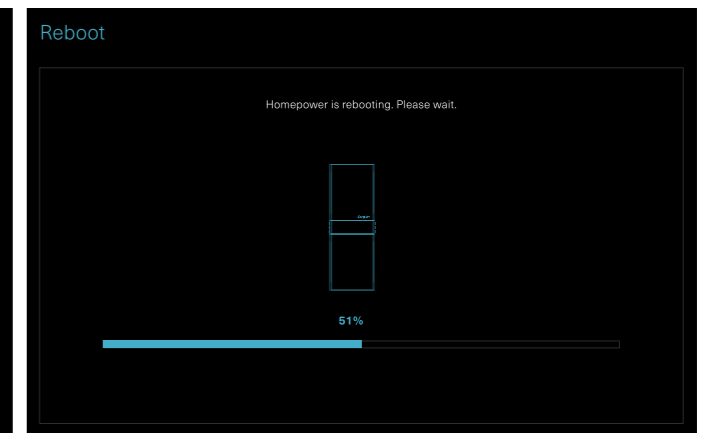

Fig. 13. Reboot Status (*Customer Portal*)

Step 2 – Shut Down Sequence (HP-6M/HP-6S)

In order to power off the *Energizer* Homepower HP-6 Series system completely, you will be required to follow the procedure listed below, in conjunction with the technical advice received from your system provider.



Energizer Homepower HP-6 Series are not user serviceable and repairs must not be carried out by system owners. Do not open the Installer Access Panel inside either the Main Unit or Sub Unit as exposed wiring can present a risk of electrical shock.

1. If Backup/UPS loads are connected, turn off respective AC Isolators.
 - a. If applicable, turn off any AC Isolators connected on the backup side.
2. Turn off the Main AC Isolator, connected to the *Energizer* Homepower HP-6 Series system.
 - a. If applicable, turn off any AC Isolators connected on the grid side.
3. Turn off the Battery Isolators on all connected units as described below:
 - a. Lift the Magna-Flap on the HP-6M as shown in Fig. 14. to uncover the Installer Access Panel, housing the Battery Isolator and the LCD.



Note: On the Battery Isolator, Red indicates ON and Green indicates OFF.

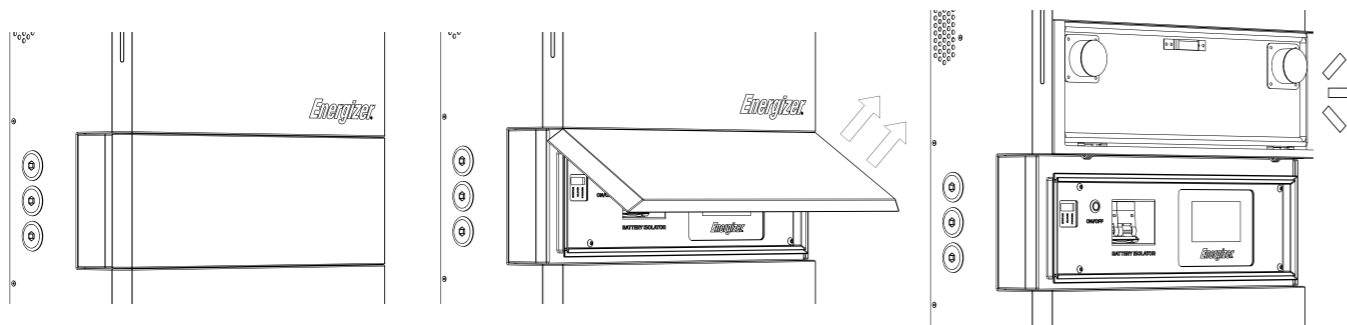

Fig. 14. HP-6M Magna-Flap & Installer Access Panel

- b. If HP-6S unit(s) are installed, lift the Magna-Flap to uncover the Installer Access Panel, housing the Battery Isolator.

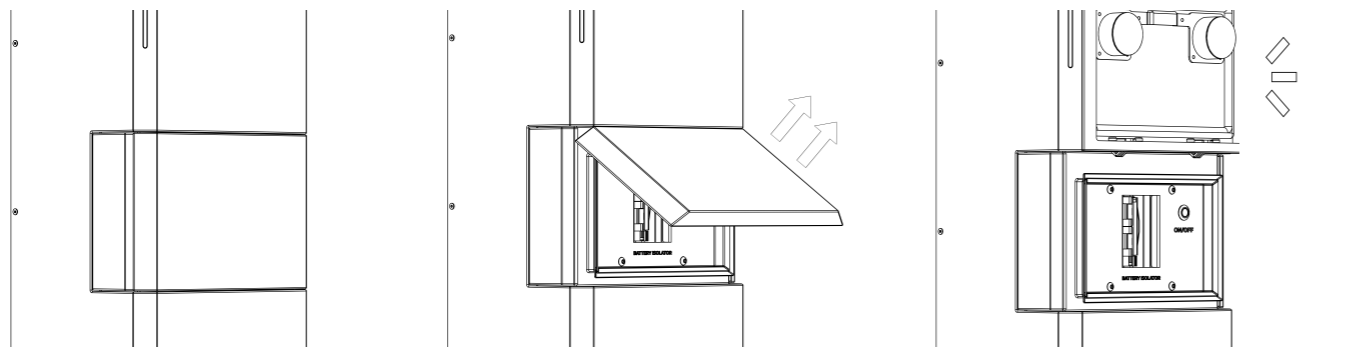

Fig. 15. HP-6S Magna-Flap & Installer Access Panel

- c. The Magna-Flaps on the HP-6M (and HP-6S) units shall magnetically attach to the metal casing/body of the unit directly above.



The recommended sequence for turning on the Battery Isolators is HP-6M first, followed by the adjacent HP-6S units.

4. Press and hold the ON/OFF Switch on the HP-6M, until a long buzzer noise is heard. Repeat the same for all connected HP-6S unit(s). At this stage, you have powered off the *Energizer* Homepower HP-6 Series systems.
5. Return the Magna-Flaps to their original position on the HP-6M and all connected HP-6S units.



Wait at least five minutes for the system to completely de-energize.

Step 3 – Power On Sequence (HP-6M/HP-6S)

In order to power on the *Energizer* Homepower HP-6 Series system, you will be required to follow the procedure listed below:

1. Press and hold the ON/OFF Switch on the HP-6M, until a short buzzer noise is heard in conjunction with a flicker of the Edge Lighting. Repeat the same for all connected HP-6S units. At this stage, you have powered on the *Energizer* Homepower HP-6 Series system.
2. Turn on the Battery Isolators on the HP-6M and all connected HP-6S units.



The recommended sequence for turning on the Battery Isolators is HP-6M first, followed by the adjacent HP-6S units.

3. Turn on the Main AC Isolator connected to the *Energizer* Homepower HP-6 Series system.
 - a. If applicable, turn on any AC Isolators.
4. Return the Magna-Flaps to their original position on HP-6M (& all connected HP-6S) units.
5. If Backup/UPS loads are connected, turn on respective AC Isolators.
 - a. Turn on any AC Isolators if applicable.
6. The system shall turn ON and resume normal operation now.



DANGER! Please do not attempt to disassemble the HP-6M or HP-6S in any way, as it may cause damage to the product. Unsolicited disassembly shall void any applicable manufacturer (or performance) Warranty.

Step 4 - Technical Resolutions

If the system fault remains, first attempt to connect your system to the internet and ensure you have all relevant information pertaining to the fault, such as system serial number, contact information and a general description of the issue prior to contacting your system provider.

4. Emergency Procedures

The *Energizer* Homepower HP-6 Series has a lithium ion battery that contains several chemicals and organic electrolytes, which are hermetically sealed within a metal enclosure. There is no risk of chemical exposure under routine use of the unit's specific application. In case of an emergency, where there is a genuine threat to health or safety, contact emergency personnel or fire response teams immediately and present the Safety Datasheet (SDS).



DANGER! Do not perform the suggested actions listed below unless it is safe to do so.

In case of a fire:

- Inform all affected people e.g., family, neighbours etc of the issue and evacuate the area.
- Turn off the AC Isolators connected to the HP-6M unit within the switchboard.
- Use dry chemical (ABC), carbon dioxide or alcohol resistant foam extinguishers.
- Do not use water jets or streams, as it may scatter or spread chemicals.

In case of smoke or related smells:

- Turn off all Battery Isolators on HP-6M and associated HP-6S units.
- Turn off the AC Isolators connected to the HP-6M unit within the switchboard.
- Ventilate the location of the *Energizer* Homepower unit(s).
- If smell persists, contact your *Energizer* Homepower reseller.

In case of water leakage and/or flooding:

- Inspect from a safe distance to ensure that the *Energizer* Homepower HP-6 Series system and/or associated electrical equipment are not submerged. Ensure to stay out of water surrounding the system.
- If safe to approach, turn off the AC Isolators connected to the HP-6M unit within the switchboard.
- Stop the source of water leakage, by redirecting flow and/or contacting plumbing services.
- In case the unit is submerged, do not approach until water level has receded and capture images of damage.
- Contact your *Energizer* Homepower authorised reseller for further troubleshooting and/or safe product recovery procedures.



DANGER! Do not turn on the system prior to receiving technical advice and/or without the written consent of your *Energizer* Homepower Certified Distributor.

5. First Aid Measures

If the battery is physically damaged & results in battery leakage, the following measures must be taken to reduce the impact of the exposure. Any accidental exposure to the electrolytes or chemicals must be treated immediately with first aid.

- Present the Safety Data Sheet (SDS) to the medical professional in attendance.
- Eyes - flush eyes with water for at least 15 minutes, occasionally lifting the upper & lower eyelids. Seek medical attention if eye irritation persists.
- Skin - remove contaminated clothes and rinse skin with plenty of water or shower for 15 minutes. Seek medical attention if skin irritation persists.
- Ingestion - do not induce vomiting or place anything into the mouth of an unconscious person. For advice, contact a Poison Information Centre on 13 11 26 (Australia wide) or a doctor at once.
- Inhalation - evacuate the affected from the hazardous area and allow them to rest in a position comfortable for breathing with access to fresh air.
- Adverse effects not expected to occur from this product. Long term exposure may cause substance accumulation and/or irritation.
- Medical attention - treat symptomatically. If symptoms persist, get medical aid by calling a physician for appropriate medical advice.

6. Safety Datasheet

1. Product Name & Identification

1.1. Product Identifier:

- 1.1.1. Product Name: *Energizer* Homepower HP-6 Series.
- 1.1.2. Models: HP-6M, HP-6S, HP-6M/1S, HP-6M/2S and HP-6M/3S.
- 1.1.3. Other Means of Identification:
 - *Energizer* Lithium Iron Phosphate (LiFePO₄) BESS.
 - Rechargeable Li-ion Battery Energy Storage System.
 - Rechargeable Li-ion Battery.
 - UN 3480 - Lithium Ion Batteries.
- 1.1.4. Product Description: The *Energizer* Homepower HP-6 Series consists of the Main Unit (HP-6M) & the Sub Unit (HP-6S), each containing 16 Lithium Iron Phosphate cells, a Battery Management System (BMS) and other associated Electronics.

1.2. Product Use:

- 1.2.1. Identified Uses: intended to be used as an AC coupled Battery Energy Storage System.
- 1.2.2. Use Restrictions: operate the battery under the following conditions:
 - Temperature Range: -20°C to 50°C (Operating Temperature).
 - Store batteries preferably in a cool, dry, and ventilated area that is subject to minimal variations in ambient temperature. Storage at high temperatures should be avoided. Storage of batteries for periods exceeding 6 months without charging, can lead to battery decay and fall in the life cycle. Do not place batteries near heat sources such as furnaces.

1.3. Details of the Importer of the Safety Data Sheet:

Entel Holdings ANZ Pty. Ltd.
 Level 1, 12 Rislely Street,
 Richmond VIC 3121
 AUSTRALIA
 +61 (03) 9110 1001
 Website: energizerhomepower.com
 Email: support@energizerhomepower.com

1.4. Emergency Telephone Number (24hrs):

O: +61 (03) 9110 1001
 M: +61 (0) 499 666 600

2. Hazard Identification

The battery cell is contained in a hermetically sealed metal case, designed to withstand temperatures and pressures encountered under routine use for the unit's specific applications. As a result, under normal operation there is no physical danger of ignition or explosion and/or chemical danger of exposure to hazardous materials. The risk of exposure only occurs if the product is electrically, thermally (exposed to fire) or mechanically (severe shocks) abused. As a result, if the sealed metal case is breached, exposure to hazardous chemicals may occur by eye contact, skin contact and ingestion.

2.1. Hazard Classification

EXEMPT FROM CLASSIFICATION ACCORDING TO AUSTRALIAN WHS REGULATIONS.

Further, this product meets the definition of an 'Article'. Under the Globally Harmonized System of Classification and Labelling of Chemicals (GHS), 'Articles' as defined in the Hazard Communication Standard (29 CFR 1910.1200) of the Occupational Safety & Health Administration (USA), or by similar definition, are outside the scope of the system. [Rev 7 (2017) Part 1.3.2.1.1]

- 2.2. GHS Label Elements: no labelling applicable.
- 2.3. Hazard Statement: no additional information available.
- 2.4. Precautionary Statement: no additional information available.
- 2.5. Hazards not covered by GHS: no data available.

3. Composition/Information on Ingredients

3.1. Substances/Mixtures:

Chemical Name	CAS #	EC No.	Weight (%)
Phosphoric Acid, Iron (2+), Lithium Salt (1:1:1)	15365-14-7	476-700-9	N/A
Aluminium	7429-90-5	231-072-3	N/A
Graphite	7782-42-5	231-955-3	N/A
Copper	7440-50-8	231-159-6	N/A
Polyethylene	9002-88-4	200-815-3	N/A
Phosphate (1-), Hexafluoro-, Lithium	21324-40-3	244-334-7	N/A

4. First Aid Measures

The *Energizer* Homepower HP-6 Series has a lithium ion battery that contains several chemicals and organic electrolytes, which are contained within a sealed metal enclosure. There is no risk of chemical exposure under routine use of the unit's specific application. Any accidental exposure to the electrolytes or chemicals must be treated immediately with First Aid. If the battery is physically damaged & results in battery leakage, the following measures must be taken to reduce the impact of the exposure.

4.1. Description of First Aid Measures

4.1.1. General Advice:

- Present this Safety Data Sheet to the Medical Professional in attendance.
- Eyes: flush eyes with water for at least 15 minutes, occasionally lifting the upper & lower eyelids. Seek medical attention if eye irritation persists.
- Skin: remove contaminated clothes and rinse skin with plenty of water or shower for 15 minutes. Seek medical attention if skin irritation persists.
- Ingestion: do not induce vomiting or place anything into the mouth of an unconscious person. For advice, contact a Poison Information Centre on 13 11 26 (Australia wide) or a doctor at once.
- Inhalation: evacuate the affected from the hazardous area and allow them to rest in a position comfortable for breathing with access to fresh air.

4.1.2. Most Important Symptoms Caused by Exposure:

- Adverse effects not expected to occur from this product. Long term exposure may cause substance accumulation and/or irritation.

4.1.3. Medical Attention - treat symptomatically. If symptoms persist, get medical aid by calling a physician for appropriate medical advice.

5. Fire-Fighting Measures

5.1. Hazard Classification:

- Suitable: dry chemical, carbon dioxide, or alcohol-resistant foam extinguishers.
- Unsuitable: do not use water jets/streams, as it may scatter or spread chemicals.

5.2. Specific Hazards:

- Lithium Iron Phosphate batteries contain flammable liquid electrolyte that may vent, ignite & generate vapours when subjected to excessive heat.
- There are unusual fire and explosion hazards associated with the batteries.
- There are several hazardous products that could be emitted as result of combustion such as carbon monoxide, carbon dioxide & lithium oxide fumes.

5.3. Special Protective Actions for Fire Fighters:

- Wear full personal protective equipment including self-contained breathing apparatus (SCBA) when combating fire.
- Remain upwind and notify those downwind of hazard to evacuate area, as toxic gases may be evolved in a fire.

6. Accidental Release Measures

6.1. Personal Precautions, Protective Equipment and Emergency Procedures:

- Evacuate personnel to a safe area until fumes dissipate.
- Eliminate all ignition sources (no smoking, sparks, flames, hot equipment) in the immediate area around the spill.
- Provide maximum ventilation to clear out hazardous gases.
- Do not touch or walk through spilled material.
- Avoid any skin and eye contact or inhalation of vapours.

6.2. Environmental Precautions:

- Absorb spilled material with non-combustible, non-reactive absorbent.
- Prevent from leaking of the spilled material into the sewers, earth & natural waterways.

6.3. Environmental Precautions:

- Clean any residual electrolyte and liquid using non-combustible, non-reactive absorbent or sand. Ensure that clean-up procedure does not expose the spilled material to the moisture.
- Containerize and place all leaking batteries in individual containers that are leak-proof, non-conductive, non-combustible & have absorbent.
- Refer to your local and federal regulations to identify the appropriate method of clean-up and disposal.

6.4. Waste Disposal Method:

- It is recommended to discharge the batteries entirely and handing over the abandoned batteries to the appropriate hazardous chemical disposal authority.
- Dispose of the batteries in accordance with the approved Local, State & Federal requirements.
- Consult State Environmental Protection agency and/or Federal EPA when necessary.

7. Handling & Storage

7.1. Precautions for Safe Handling:

- The batteries should not be opened, destroyed, or incinerated, as they are susceptible to leak or rupture, and subsequently could release harmful chemicals into the environment.
- Do not short circuit terminals, or overcharge the battery, force over-discharge, or throw batteries into the fire.
- Do not crush or puncture the battery or immerse in liquids.
- Avoid mechanical or electrical abuse of batteries.
- Ensure that batteries are stored in a cool, dry, and ventilated area, that is subject to minimal temperature variation.
- Storage at high temperatures should be avoided to increase the longevity of the battery cells.
- Batteries must not be placed near heating equipment, nor be exposed to direct sunlight for long periods.

7.2. Other Precautions:

- Batteries may explode or cause burns if disassembled, crushed, or exposed to fire or high temperatures.
- Do not short or install with incorrect polarity.

7.3. Conditions for Safe Storage:

- Store indoors and on suitable pallets to enable easy inspection of damage.
- Ensure the items do not encounter water splashes or direct salt breeze.
- Store away from all heat sources such as furnaces, open flames, etc.
- Store in controlled environments where the temperature is maintained within the following range: -20 °C to 45 °C.
- Do not store unboxed items in areas with a source of spark generation (within 30 cm), in direct sunlight, in direct exposure to exhaust gases, such as those from automobiles or in places with continuous or intermittent vibration.

8. Exposure Controls & Personal Protection

8.1. Control Parameters

8.1.1. Occupational Exposure Limit Values:

Component	Country/Region	Limit Value			
		Eight Hours		Short Term	
		ppm	mg/m3	ppm	mg/m3
Aluminium 7429-90-5	USA (OSHA)	-	15	-	-
	South Korea	-	10	-	-
	Ireland	-	1	-	-
	Germany (DFG)	-	4	-	-
	Denmark	-	5	-	10
	Australia (SWA)	-	10	-	-
Graphite 7782-42-5	USA (OSHA)	-	15	-	-
	South Korea	-	2	-	-
	Ireland	-	10	-	-
	Germany (DFG)	-	4	-	-
	Denmark	-	2.5	-	5
	Australia (SWA)	-	3 (4)	-	-
Copper 7440-50-8	Netherlands	-	0.1	-	-
	Poland	-	0.2	-	-
	Latvia	-	0.5	-	1
	Germany (DFG)	-	0.01	-	0.02

8.1.2. Biological Limit Values: no information available

Component	Source	Biological Monitoring Index	Biological Limits Value	Sampling Time	Remark
Phosphate (1-), hexafluoro-, Lithium	SCOEL (EU)	Fluoride in Urine	8mg/L	End of shift	-

8.1.3. Monitoring Methods

- EN 1402 Workplace Atmospheres – guide for the application and use of procedures for the assessment of exposure to chemical and biological agents.
- GBZ/T 160.1 ~ GBZ/T 160.81-2004 Determination of toxic substances in workplace air (Series standard).

8.2. Exposure Controls

8.2.1. Engineering Controls

- Ensure adequate ventilation, especially in confined areas.
- Ensure that eyewash stations and safety showers are close to the workstation.
- Use explosion-proof electrical/ventilating/lighting/equipment.
- Setup emergency exit and necessary risk-elimination area.

8.3. Personal Protective Equipment

- 8.3.1. Eye Protection: well fitted Safety Glasses (worn under shield), as approved by EN 166 (EU) or NIOSH (US).
- 8.3.2. Hand Protection: leather and voltage rated gloves in accordance with EN 374 (EU), US F739 or AS/NZS 2161.1.
- 8.3.3. Respiratory Protection: airborne exposure to hazardous substances in the electrolyte is not expected when the cells of batteries are used for their intended purposes. In case of battery venting or if exposure limits are exceeded, use a full-face respirator type AXBEK (EN 14387).
- 8.3.4. Skin and Body Protection: arc-rated long sleeve shirt, arc-rated pants or overalls, arc-rated face shield with hard-hat, hearing protection and leather work shoes, in accordance with AS/NZS 5139.

9. Physical and Chemical Properties

- 9.1. Appearance: lithium ion batteries enclosed within protective metal case.
- 9.2. Nominal Voltage: 51.2V.
- 9.3. Rated Capacity: 120Ah.
- 9.4. Odour: no information available.
- 9.5. Melting Point or Freezing Point (°C): no information available.
- 9.6. Flammability: no information available.
- 9.7. pH: no information available.
- 9.8. Evaporation rate: no information available.

10. Stability & Reactivity

- 10.1. Chemical Stability: stable under proper operation & storage conditions.
- 10.2. Reactivity: contact with incompatible substances can cause decomposition or other chemical reactions.
- 10.3. Possibility of Hazardous Reactions: exposed ultra-fine powder may self-ignite in room-temperature. Mixtures with metallic acetylene, when heated, cause a fire or incandescence. Reacts severely with halogens, interhalogen or other strong oxidants.
- 10.4. Conditions to Avoid: avoid exposure to heat and open flame, heating, mechanical (mutilation, crushing and disassembly) and electrical (short circuit) abuse.
- 10.5. Materials to Avoid: oxidants, halogen, interhalogen and mercury, metal acetylide, halogen oxides, nitric acid, nitrous oxide, nitrates, nitrites, halogen oxyacid salts, chromates, permanganates, inorganic peroxides, metal oxides, peroxyboric acid, water, corrosives, acids and alkalis.
- 10.6. Hazardous Decomposition Products: under normal conditions of operation and storage, no hazardous decomposition products are produced.

11. Toxicological Information

Under normal conditions, any contact with a fully sealed, protected battery is non-toxic. If the battery is opened, the exposure to internal contents such as corrosive fumes can cause irritation to skin, eyes, and mucous membranes. Inhalation, skin contact, and eye contact must be avoided when possible.

- Acute Toxicity: no specific data exists for this product. Batteries are contained in a hermetically sealed metal case that contain several chemicals, which may be hazardous upon release. Exposure unlikely to occur with normal operation, however in such a case contents may be harmful.
- Carcinogenicity:

ID	CAS No.	Component	IARC	NTP
1	15365-14-7	Phosphoric Acid, Iron (2+), Lithium Salt	Not Listed	Not Listed
2	7429-90-5	Aluminium	Not Listed	Not Listed
3	7782-42-5	Graphite	Not Listed	Not Listed
4	7440-50-8	Copper	Not Listed	Not Listed
5	9002-88-4	Polyethylene	Category 3	Not Listed
6	21324-40-3	Phosphate (1-), Hexafluoro-, Lithium	Not Listed	Not Listed

12. Ecological Information

When promptly and safely used or disposed, the battery does not present any environmental hazard. While disposing, please ensure that it is disposed in accordance with local and federal regulations.

- Acute Aquatic Toxicity

ID	CAS No.	Component	Fish	Crustaceans	Algae
1	7429-90-5	Aluminium	LC50: 1.55 mg/L (96h) (Fish)	No information available	No information available
2	7440-50-8	Copper	LC50: 0.665 mg/L (96h) (Fish)	EC50: 0.02 mg/L (48h)	ErC50: 7.9 mg/L (96h)

- Persistence and Degradability - no information available.
- Bio accumulative Potential - no information available.
- Mobility in Soil - no information available.
- Results of PBT and VPvB Assessment - phosphoric acid, iron (2+), lithium salt, aluminium, graphite, copper, polyethylene and phosphate (1-), hexafluoro-, do not meet the criteria for PBT and VPvB assessment as per regulation (EC) No. 1907/2006, annex XIII.

13. Disposal Considerations

Waste Chemicals - if batteries are still fully (or partially) charged or discharged, they can be considered a reactive hazardous waste. The batteries must be disposed in accordance with local and federal laws and regulations, through licensed waste carriers and/or suitable recycling facilities etc.

Product Enclosure – the enclosure or protective case may still present a chemical hazard when empty. The batteries must be disposed in accordance with local and federal laws and regulations, through licensed waste carriers and/or suitable recycling facilities etc.

14. Transport information

Classified as a Dangerous Good by the criteria of the ADG Code.

Transporting Label:



UN Number: UN3480
 UN Proper Shipping Name: LITHIUM ION BATTERIES (including Lithium Ion polymer batteries)
 Transport Hazard Class: Class 9
 Packing Group Number: packing group II (As per GHS Regulations)
 Environmental Hazards (Transport): follow all applicable local, state, and federal requirements when identifying additional environmental hazards.

15. Regulatory Information

The battery complies with the following stipulated regulations:

Component	EINECS	TSCA	DSL	IECSC	NZIoC	PICCS	KECI	AICS	ENCS
Phosphoric Acid, Iron (2+), Lithium Salt	-	✓	-	-	-	-	✓	-	-
Aluminium	✓	✓	✓	✓	✓	✓	✓	✓	-
Graphite	✓	✓	✓	✓	✓	✓	✓	✓	-
Copper	✓	✓	✓	✓	✓	✓	✓	✓	-
Polyethylene	-	✓	✓	✓	✓	✓	✓	✓	-
Phosphate (1-), hexafluoro-, Lithium	✓	✓	-	✓	-	✓	✓	✓	-

Note:

" ✓ " Indicates that the substance is included in the regulations.

" - " Indicates that no data or not included in the regulations.

- [EINECS] The European Inventory of Existing Commercial Substances
- [TSCA] The Toxic Substances Control Act
- [DSL] Canadian Domestic Substances List
- [IECSC] China Inventory of Existing Chemical Substances
- [NZIoC] New Zealand Inventory of Chemicals
- [PICCS] Philippines Inventory of Chemicals & Chemical Substances
- [KECI] Korea Existing Chemicals Inventory
- [AICS] Australia Inventory of Chemical Substances
- [ENCS] Existing & New Chemical Substances

16. Additional Information

DISCLAIMER: The information and recommendations set forth in this Safety Data Sheet were prepared in accordance with the "Safe Work Australia's Code of Practice: Preparation of Safety Data Sheets for Hazardous Chemicals [May 2018]" and the UN GHS [7th Revised Edition]. The data included is derived from various sources and believed to be accurate as of the date of preparation. However, Entel Holdings ANZ Pty. Ltd. does not assume responsibility for any alterations, modifications, or usage of this product outside of the methods prescribed as per this document. This information is furnished upon condition that person receiving it shall make his own determination of the suitability of the material for their particular purpose.

Prepared by:
 Entel Holdings ANZ Pty. Ltd.
 Level 1, 12 Risley Street, Richmond VIC 3121, AUSTRALIA
 Date of Preparation: 04.10.2020

7. Limited Warranty (Australia & New Zealand)

Date of Effect – Aug 28th, 2020

This limited manufacturer's Warranty applies to the residential application of the *Energizer* Homepower HP-6 Series distributed by Entel Holdings ANZ Pty Ltd, ("Entel"), and applies to the below mentioned products.

The *Energizer* Homepower HP-6 Series Products are:

Product	Description	Serial Number
HP-6M	Pre-intergrated Battery Energy Storage System (includes 3.6 kW AC coupled Inverter, Battery Module and BMS)	A1AU001010000
HP-6M/1S		
HP-6M/2S		
HP-6M/3S		
HP-6M	Additional Battery Storage only (includes battery module and BMS)	B1AU0010020000

Table 1. *Energizer* Homepower HP-6 Series Products

Warranty Terms

If you are a consumer and have purchased any of the above-mentioned products, Entel shall provide this Warranty consisting of a "Battery Performance Warranty" and a "Product Warranty", in addition to your rights under consumer laws in your jurisdiction. Please note the Limited Warranty is subject to certain limitations and exclusions, that are described in detail below.

1. Product Warranty

We warrant that your *Energizer* Homepower HP-6 Series products will be free from defects for a period of 10 years following the earlier of (a) three months from the battery's date of manufacture or (b) the initial installation date at its original location.

2. Battery Performance Warranty

- System operating in automatic mode, where excess energy from solar is stored in batteries and discharged towards house loads and loads connected to back-up.

Product	Energy Retention	Operation Limitation
Normal operation ¹	Retain 80% of usable capacity ² after 10 years of date of initial installation	10,000 Cycles
Other applications ³	Retain 80% of usable capacity ² after 10 years of date of initial installation	Total Energy Dispatch of 3 MWh per kWh ⁴

Table 2. Battery Performance

- Usable capacity at the time of installation is 95% of Rated Energy, as stated on the Product Datasheet.
- Any other applications other than "normal operation".
- Normal operation and other applications combined operation limitation equals 10,000 cycles.

If there is a subsequent increase in the overall system capacity by adding one or more Sub Units (HP-6S) at a later date ["Subsequent Product"], we warrant that the subsequent product shall retain its usable capacity as described in the table aforementioned. Please note this Limited Warranty is subject to several important limitations and exclusions, in addition to meeting certain conditions which are set out in the following pages.

3. Eligibility

- Products must be purchased from Entel, or an *Energizer* Homepower authorised reseller in Australia or New Zealand.
- Product failure should have occurred within the Warranty period as described in Section 1 (Product Warranty).
- Product must include a Serial Number in the format referenced in Table 1.
- Product must be installed, wired, and commissioned by an *Energizer* certified installer (CEC accredited) in Australia or New Zealand.
- Product owner (or end user) must be able to present proof of ownership.
- If product ownership has been transferred, then subsequent owners must acquire proof of ownership from the original owner.
- Product owner (or end user) must have operated and/or used the product strictly as per the product owner's manual.
- Third-party or external inverter/battery pack(s) must not have been installed with the product and the system configuration must comply with the product specifications.
- Proof may be required of correct commissioning of the product (such as certificate of compliance). Claims for failures due to incorrect installation or commissioning are not covered under this Warranty.
- A commissioning report signed by the end user and the installer for product commissioning and handling instructions shall be sent to Entel.

4. What is Offered?

If your product fails to comply with the above Warranty Entel will, in its sole discretion, either repair your product, replace it with an equivalent product, or compensate you with the market price of an equivalent product at the time of the Warranty claim. Any product that is presented for repair may be replaced with an equivalent refurbished product instead of being repaired. If your product is repaired or replaced under this Warranty, then the repaired or replaced product will benefit from the remainder of the original Warranty period, subject to any rights that you may have under local laws and regulations in your country or region. However, if Entel has discontinued the production of the product due to technological advancements, Entel will replace the product with a different type of product of at least same value or similar functions, although the replacement product may be a different size, shape, colour, and/or capacity. Because of technical advancements, it is possible that replacement parts or components may not be compatible with the original components already installed. Any costs relating to the incompatibility of systems is not covered by this Warranty.

5. What is Excluded?

This Limited Warranty will not apply to defects or reduction in energy capacity arising from any of the following circumstances, each of which may result in the Warranty being voided.

- The product(s) are damaged by end user's improper usage, storage, or operation, that does not conform with instructions in the product owner's manual.
- Handling, installation (including removal and/or reinstallation), wiring, or commissioning of the product other than in accordance with instructions in the installation manual.
- Operation, use, or maintenance of the product without following instructions in the product owner's manual or without reasonable care (including failure to maintain or clean the product in accordance with recommendations in the product owner's manual).

- Any attempt at modifying the product, whether physically or by means of software programming without the express consent of Entel.
- Removal and relocation of your product to a different location, without the written consent of Entel or your *Energizer* Homepower authorised reseller.
- Product abuse, misuse, or negligence.
- Transportation, storage, installation, commissioning, wiring, modification, or repair performed by anyone other than Entel or an *Energizer* Homepower certified installer.
- As a result of changes which occur in the condition or operational performance of the product for climate or other environmental influence, foreign material contamination (e.g. smoke, salt and chemicals, etc.), water entry, exposure to excessive heat or solvents, or because of use of the product with insufficient ventilation (in particular the maximum temperatures according to the product owner's manual), exposure to strong vibrations, or damage due to exposure to a strong magnetic field.
- Unusual physical or electrical damage caused by force majeure events, including but not limited to lightning, earthquakes, cyclones, floods, fires, or other events outside the control of Entel.
- Exposure to generalised corrosion, normal wear, and tear (or deterioration), biological infestations, noise, or vibration that is not excessive, or any other defects that do not have an impact on the system performance or degrade its functions.
- Faulty electrical components attached to other equipment (such as solar systems, HVAC systems, third-party electrical meters) not supplied by Entel.
- Any damage that may occur after the expiration or voiding of the Warranty period.
- Use of *Energizer* Homepower products as a primary or backup power source for life-support systems, other medical equipment, or any other use where product failure could lead to injury to persons or loss of life or catastrophic property damage.
- Due to accidental damage, theft, or vandalism, or use of the product for a purpose other than normal applications or in environmental conditions for which the product was not designed or sold or use of the product outside the specified or normal operating ranges.
- If the defect occurs during shipping or transportation after the product is sold to an *Energizer* Homepower authorised reseller.
- If product failure is not reported to Entel or *Energizer* Homepower authorised reseller within 2 weeks of appearance and damage caused by continued use of the product following the knowledge of a defect.
- As a result of repairs, alterations, or modifications to the product which have been performed by a third party not authorized by Entel.

In addition, Entel requires the ability to monitor your product and carry out over-the-air (remote) firmware upgrades via the *Energizer* Homepower Cloud. To avail the full 10-year Warranty, the end user must register their product and have a reliable internet connection. By doing so, you consent to Entel conducting these upgrades without further notice to you. Please bear in mind these upgrades may interrupt the operation of your product for a short period. If your product is not registered or connected to the internet (*Energizer* Homepower Cloud) for an extended period of time, Entel or *Energizer* Homepower authorised resellers may contact you with a resolution. If we are unable to establish a contact or ensure the system remains connected, we may reduce your Warranty period to four years, following the date of the product installation for the first time, subject to the exclusions and limitations set out in the Warranty.

6. Warranty Waivers

Entel does not authorise the modification or waiver of any part of this Warranty by any person or entity. Entel, in its sole discretion, may occasionally offer to pay for some or all of the cost of certain repairs that may not be covered by this Warranty, on a case-by-case basis. Entel reserves the right to do so at any time without incurring any obligation to offer a similar payment to other product owners.

7. Limitation of Liability

Unless otherwise specified, to the maximum extent permissible by law, Entel will not be liable for any direct, indirect, special, accidental, or derivative losses caused by the purchase or use of the product and its system, including but not limited to actual or expected loss in revenue, loss in income, loss of anticipated savings, loss of business, loss of opportunity, loss of goodwill, loss of reputation, personal injury, or the indirect or derivative loss of damage, regardless of whether Entel has been informed of, or otherwise might have anticipated, the possibility of such losses. To the maximum extent permissible by law, Entel's liability arising out of a claim under this Warranty from any cause whatsoever shall in no event exceed the product purchase price paid by the end user to Entel, for such a product giving rise to the liability. Exceptions to this liability will only be on the grounds of culpable injury to life, physical injury, or injury to health and the mandatory liability from intent or gross negligence.

8. Applicable Law

The Limited Warranty applies in addition to guarantees provided under the Australian Consumer Law (ACL). Our goods come with guarantees that cannot be excluded under the Australian Consumer Law. You are entitled to a replacement or refund for a major failure and compensation for any other reasonably foreseeable loss or damage. You are also entitled to have the goods repaired or replaced if the goods fail to be of acceptable quality and the failure does not amount to a major failure.

The Limited Warranty is provided in addition to, and does not exclude, restrict, or limit any rights a customer has under the Consumer Guarantees Act 1993 and the Fair-Trading Act 1986 (The "New Zealand Consumer Law"). If the product is acquired for the purposes of a business, then the consumer guarantees act 1993 shall not apply. Your rights under New Zealand Consumer Law may also apply to any repaired or replacement product.

9. RMA Process

In order to make a claim under this Warranty, please contact the *Energizer Homepower* authorised resellers that sold you the product, and provide them with (a) original proof of purchase and any subsequent transfers of ownership, (b) relevant product Serial Number and installation date, and (c) a description of the alleged product defects. If you are unable to contact the *Energizer Homepower* authorised resellers, or if you purchased your product directly from Entel, you must contact us using the email address or telephone numbers listed below, raise a service request with Entel, and obtain a Return Merchandise Authorisation (RMA) number. Products must not be returned to Entel without a suitable RMA Number.

8. I&C Checklist

Following the Installation of the *Energizer Homepower HP-6 Series*, ensure that you complete the below checklist and share a record with your system provider. It is also recommended that installers retain records of the equipment installed.

No.	Items	Component			
1	Date of Installation & Commissioning	/ /			
2	System Provider (Contact Details)	Company Name: Phone Number: Email:			
3	<i>Energizer Homepower</i> Model No.	<input type="checkbox"/> HP-6M	<input type="checkbox"/> HP-6M/1S	<input type="checkbox"/> HP-6M/2S	HP-6M/3S
		HP-6M [Main Unit] S/N: HP-6S [Sub Unit] S/N (1): S/N (2): S/N (3):			
4	Total Battery Storage Capacity (kWh)				
5	<i>Energizer Homepower</i> Model No.	<input type="checkbox"/> CTS only	<input type="checkbox"/> CT and Digital Meter	<input type="checkbox"/> Digital Meter only	
		If Digital Meters are installed, • Model No: • No. of Meters:			
6	Initial System Settings	Contact system provider to receive all system settings. Firmware info: • Current FW Version: • Current Protocol Version: • Coms Module FW Version:			
7	Initial System Settings	Grid Status - On		Grid Status - Off	
	Is the Battery Charging?	<input type="checkbox"/> Yes	<input type="checkbox"/> No	N/A	
	Is the Battery Discharging?	<input type="checkbox"/> Yes	<input type="checkbox"/> No	<input type="checkbox"/> Yes	<input type="checkbox"/> No
8	If Backup/UPS is Connected, does the battery discharge towards connected loads when utility grid is turned off?	<input type="checkbox"/> Yes		<input type="checkbox"/> No	
9	Is the Battery Charging?	<input type="checkbox"/> Yes		<input type="checkbox"/> No	

Induction Requirements

Following the Installation of the *Energizer Homepower HP-6 Series*, please ensure that the system owner or nominated representative is provided the following information:

- Demonstration of the system shutdown & start-up procedures, Introduction to the system manual.
- Explanation of the alarm/faults that may arise with the system.
- Contact details of manufacturer/system provider.
- Basic system operation & design principles.

Further, ensure that a copy of the below customer acknowledgement is provided to the system provider for installation records.

Customer Acknowledgement

I, _____ (Customer) acknowledge that _____ (System Provider) has attended my property and conducted the requested work. I confirm that the installer attending my property has completed the installation based on his/her recommendation for the most efficient energy production, provided me all the information as per the induction requirements and I confirm that I have agreed to this install location.

ACKNOWLEDGEMENT:

Customer's Signature _____

Installer's Signature _____

Date _____

Date _____

Risk Assessment

Energizer Homepower [Model No.]	HP-6M	HP-6M/1S	HP-6M/2S	HP-6M/3S
DVC Level	DVC-A (Battery)			
Battery product type as per AS/NZS 5139:2019	DVC Level			
Assessed by	CEC Approved BESS			
Date of Assessment				
Reviewed by				
Date of Review				

No.	Hazard Description STEP 1	Potential Source	Potential Consequences	Inherent Risk STEP 2	Controls STEP 3	Residual Risk STEP 4
1	Electrical and other hazards	<ul style="list-style-type: none"> Contact with live conductors. Fault or short circuit current from the battery impacting the rest of the electrical installation. 	<ul style="list-style-type: none"> Electrocution. Fire. Battery overheating or a rupture leading to hazards identified below. 	High	Follow the relevant section of AS/NZS 5139:2019 such as: <ul style="list-style-type: none"> Section 3 provides the types of hazards associated with battery energy storage systems. Section 5 provides the installation requirements for CEC approved BS. 	Medium

No.	Hazard Description STEP 1	Potential Source	Potential Consequences	Inherent Risk STEP 2	Controls STEP 3	Residual Risk STEP 4
2	Energy hazards ¹	<ul style="list-style-type: none"> Arc flash from insufficient isolation or insulation. Some parts of a BS may remain energised. INCIDENT ENERGY CALCULATION 0.324 cal/cm² NOTE: See Table G5 of AS/NZS 5139:2019 Clause 3.2.4.2.1 to determine arc flash incident energy. 	Burns to eyes and skin	High	Installation and maintenance activities shall be done as per the manufacturer's instructions <ul style="list-style-type: none"> Inspect equipment for damage before installing. Remove exposed metal or conductive items such as jewellery, zips, watches. Arc flash boundary - 23.38 cm. PPE level - use PPE level 1 When working within 23.38 cm of live parts. 	Low
3	Mechanical hazards	<ul style="list-style-type: none"> Crush by weight of batteries or equipment. Crushing by falling over/tipping of batteries. BATTERY WEIGHT _____kg Site-specific hazards²: _____ 	<ul style="list-style-type: none"> Crushing to body parts. Site-specific consequences³: _____ 	Medium	Installation and maintenance activities shall be done as per the manufacturer's instructions adequate structural strength of supporting provided site-specific controls ⁴ : _____	Low
4	Fire, chemicals, and biological hazards NOTE: NA in relation to the hazard classification Table 3.1 of AS/NZS 5139:2019	<ul style="list-style-type: none"> Excessively high or low temperatures. Over and under-voltage. Overcharged or over discharged. Puncturing or failure of the battery casing. Thermal runaway. Internal short circuit. 	Burns to eyes and skin	Medium	<ul style="list-style-type: none"> CEC approved BS are not expected to create fire, chemicals, and biological hazards. See Table 3.1 of AS/NZS 5139 	Low

No.	Hazard Description STEP 1	Potential Source	Potential Consequences	Inherent Risk STEP 2	Controls STEP 3	Residual Risk STEP 4
5	Explosive gas hazards	Explosive gas generated by batteries: <ul style="list-style-type: none"> Inadvertent ignition of flammable gas. 	Burns to eyes and skin: <ul style="list-style-type: none"> Secondary injuries as a result of explosions. 	_____ ⁶	<ul style="list-style-type: none"> Follow manufacturers advice on Installation and maintenance activities. Inspect equipment for damage before installing. 	_____ ⁶
6	Toxic fumes hazards	Consult manufacturer for advice on Toxic fumes generated from different types of batteries in: <ul style="list-style-type: none"> Normal operation. Fault conditions. 	Consult manufacturer for advice on: <ul style="list-style-type: none"> Poisoning Asphyxiation Burns to airway tissues (e.g. from corrosive gases). Other consequences. 	_____ ⁷	<ul style="list-style-type: none"> Follow manufacturers advice on Installation and maintenance activities. Inspect equipment for damage before installing. 	_____ ⁷

Notes:

¹ This hazard should be considered for all CEC approved pre-assembled integrated Battery Energy Storage Systems (BESS) where the installer is required to make connections on the DC side of the system (e.g. connecting equipment that is delivered to site as two or more modules) should be considered for each individual situation.

² Site specific sources of hazards (e.g. impact from vehicles), should be considered for each individual situation.

³ Site specific sources of consequences (e.g. damage to battery system, creating toxic fume or other hazards) should be considered for each individual situation.

⁴ Site specific sources of controls (e.g. bollards) should be considered for each individual situation.

⁵ Material Safety Data Sheets shall be provided at the completion of installation (refer to AS/NZS 5139:2019 Clause 6.4.1).

⁶ Contact your manufacturer to determine the risk level for this hazard. Follow the manufacturers advice on installation and maintenance activities and install and inspect any equipment for damage before installation. Installers will also be required assess site considerations to determine the inherent risk rating and the residual risk.

⁷ Contact your manufacturer to determine the risk level for this hazard. Follow the manufacturers advice on installation and maintenance activities and install and inspect any equipment for damage before installation. Installers will also be required assess site considerations to determine the inherent risk rating and the residual risk.

Risk Assessment Form Columns Hazard description: as described in AS/NZS 5139:2019.

Potential source: any or reasonably foreseeable abnormal conditions or reasonably foreseeable misuse.

Potential consequences: the most likely outcome.

Inherent risk: cross-referencing the consequence against the likelihood of it occurring in the risk matrix (before the controls are implemented).

Controls: should consider the hierarchy of control methods described in the relevant OHS/WHS Regulations and AS/NZS 5139:2019.

Residual risk: cross-referencing the consequence against the likelihood of it occurring in the risk matrix (after the controls are implemented).

Notes:

Notes:

Energizer[®]

HOMEPower