



[Tractomas

- The most powerful prime mover in the world
up to 1,000 t towing capacity

[Tractomas and its history...

The first Tractomas types: PH640 OM 6x4 delivered to China and PH 5030 GM 8x8 delivered to Tunisia.

1979



New Renault premium cabin adapted on the Tractomas D90 8x8; delivered to China

1998

1981

Tractomas 6x6 in Egypt for the transportation of tanks and a military Tractomas 6x6 with driven axles battle tank carrier



If conventional road trucks are not powerful enough to carry out the transportation assignment, NICOLAS provides the solution with the Tractomas. Designed and built by NICOLAS since 32 years, the Tractomas has

proved its efficiency all around the world under the toughest conditions (desert, Arctic, military, mining ...), breaking the world record in 2005, as the world largest semi-truck with an entry in the Guinness World Records.



2.1



2005



World record with the production of 4 Tractomas 10x10 for South Africa. Entry in the Guinness World Records: largest semi-truck in the world.

First Tractomas fitted in particular for mining applications in Australia

2012



2013

Relaunch: the new Tractomas design



The Tractomas TR 8x8 is ideally suited for hauling heavy multiple trailers over long distances and important slopes. Range of applications include road train transportation, heavy haulage, or off highway application like in the mining industry or any application that requires outstanding power source.

Tractomas is designed to withstand the challenges you and your vehicle encounter every day. This vehicle is designed and built for quality, strength and ruggedness in every detail. Special transports require strong trucks. This truck is a hard-working profit maker.



3.1

Heavy weight Power

Powered with the C27 Caterpillar engine, the Tractomas add to the 900 hp power, a remarkable torque of 4,000 Nm.

The Tractomas provides enough power to make the toughest assignment easy.

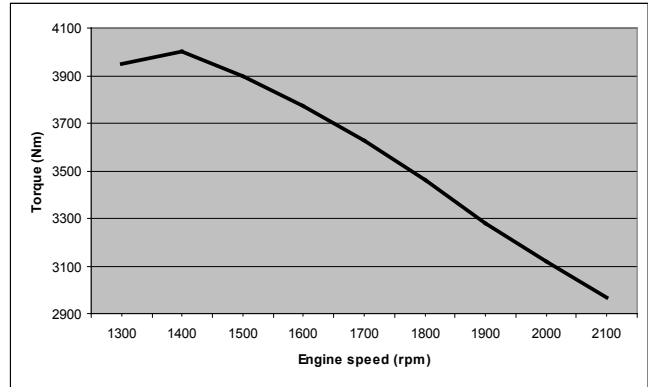
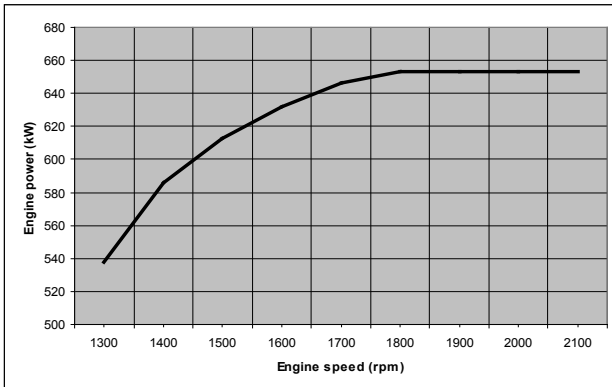

Specifications

- Turbo charged V12-4-Stroke-Cycle diesel engine
- Bore x Stroke: 137.2mm x 152.4mm
- Displacement: 27.03 litres
- Maxi power rating: 663 kW / 900 hp at 2,100 rpm
- Lube oil system: 139 litres
- Cooling system: 67 litres
- Oil temperature exchanger
- Air compressor
- Alternator 160A

Transmission

Transmission		
Allison Automatic Transmission PTO (Power Takeoff) up to 2 optional openings		
M8610	6 speed	4.24 / 0.73 Ratio (Low/High)
Optional retarder provision		
ZF Transfer case		
VG 2700	2 speed	1.407 / 0.91 Ratio (Low/High)
Pneumatically gear shift		

Axles & Suspension

Front axle and suspension
Kessler axle 12,500 kg capacity
Brakes - Carlisle disc type
Suspension - leaf springs and reactions bars
Steering axles

Rear axle and suspension
Kessler axle 25,000 kg capacity
Brakes - Knott disc type
Suspension - hydraulic and reactions bars

Technical Data

- for road and mining applications

Tractomas TR 8x8	lbs	approx.	
Dead weight	79,366	kg	36,000
Max. traction ability	1,102,311	kg	500,000
Max. load: front	27,558	kg	12,500
Max. load: rear	55,115	kg	25,000
Laden weight distribution: front		%	33
Laden weight distribution: rear		%	66
Overall length		mm	10,870
Overall width		mm	3,480
Height		mm	4,180
Height (FOPS/ROPS)		mm	4,675
Coupling height		mm	1,850
Tyres standard size			14.00 R25
Diesel tank		litre	2x1000
Coupling height drawbar		mm	700

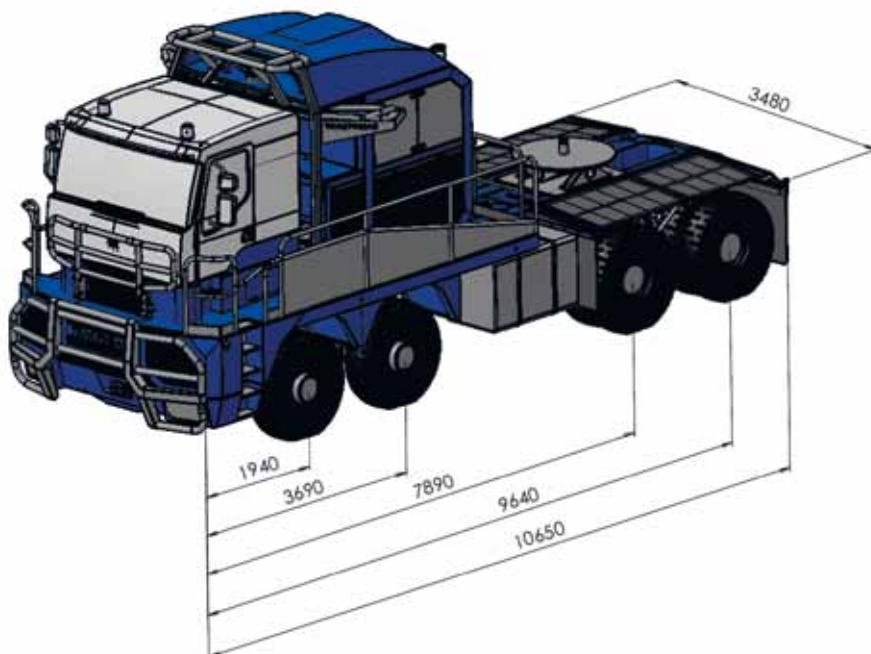
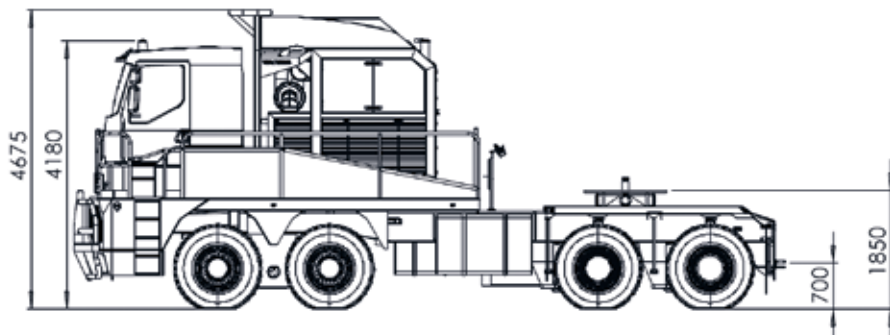

[Comfort & safety

Standard cabin

- RENAULT Kerax type
- Renault standard white painting
- 2 versions right or left driving
- Air conditioner
- Steering column adjustable
- Pneumatic tilt for easy access to transmission and driveline
- Ergonomic seating for 2 people



Interior of the standard cabin

Options for cabin

- Tinted front windshield
- CB & GPS
- Trailer command console
- Finish level of the interior of the cabin
- Pressurised cab with Brotec B10



Example of optional available cabin interiors

Safety

Design according to MDG 15 "Guideline for Mobile and transportable equipment for use in mines".

- ROPS/FOPS structure
- Control camera
- Safe rear and side access to cab via stairs
- Special lightning



ROPS/FOPS



Control camera

Accessories

- for optimal user friendly driving



Life cab and spare wheel bracket



Trailers command console option

Options

- Trailers command console
- Pressurisation system
- ROPS /FOPS structure
- CB & GPS system
- Tinted front windshield
- Quick fill wiggins system for gasoil, hydraulic oil, water, engine oil regrouped on a central service bracket
- Boomerang fifth wheel BE 450
- Spare wheel bracket allowing easy handling of the spare wheels
- Ballasts 18 t and 27 t
- Life cab with thermal insulation, 2 sleeping places, kitchen unit, water heater, water tank with a capacity of 2,000 liters



Quick fill wiggins



Boomerang fifth wheel

Competence

- NICOLAS at a glance

NICOLAS Industrie S.A.S, a French company located at Champs-sur-Yonne, was created in 1855. From that time, this company orientated its activity to designing and manufacturing handling and transport equipment. With the modernization of the industry, the development of modern production methods and the increase of the capacity of earth moving machines, the transportation field took up new challenges. NICOLAS is the expert in the market of transport and heavy handling from loads of 40 tons to over 15,000 tons. NICOLAS belongs to the TII Group (Transporter Industry International) created and managed by Otto Rettenmaier and family. Considering

the companies which are part of the group, TII is the most prominent worldwide supplier of transportation and heavy handling equipment, including the field of special vehicles.



8.1

Examples of our product range



8.2

Offshore & Plant construction



8.3

Road Transport / Industry



8.4

Road transport



8.5

Tractomas



8.6

Air & Space Industry



8.7

Agriculture



8.8

Environment



8.9

Military



8.10

Wind energy industry



NICOLAS Industrie S.A.S • RN 6 BP 3 • 89290 Champs-sur-Yonne • France
 Tel.: +33(0)386/5352-00 • Fax: +33(0)386/5352-49 • contact@nicolas.fr • www.nicolas.fr

