



DENMARK'S NATIONAL INVENTORY REPORT 2022

Emission Inventories 1990-2020 – Submitted under the United Nations Framework Convention on Climate Change and the Kyoto Protocol

Scientific Report from DCE – Danish Centre for Environment and Energy

No. 494

2022



AARHUS
UNIVERSITY

DCE – DANISH CENTRE FOR ENVIRONMENT AND ENERGY

DENMARK'S NATIONAL INVENTORY REPORT 2022

Emission Inventories 1990-2020 – Submitted under the United Nations
Framework Convention on Climate Change and the Kyoto Protocol

Scientific Report from DCE – Danish Centre for Environment and Energy

No. 494

2022

Ole-Kenneth Nielsen¹
Marlene S. Plejdrup¹
Morten Winther¹
Malene Nielsen¹
Steen Gyldenkærne¹
Mette Hjorth Mikkelsen¹
Rikke Albrektsen¹
Marianne Thomsen¹
Katja Hjelgaard¹
Patrik Fauser¹
Henrik G. Bruun¹
Vivian Kvist Johannsen²
Thomas Nord-Larsen²
Lars Vesterdal²
Inge Stupak²
Niclas Scott-Bentsen²
Erik Rasmussen³
Susanne Bødtker Petersen⁴
Lene Baunbæk⁵
Maria Gunnleivsdóttir Hansen⁶

¹Aarhus University, Department of Environmental Science

²University of Copenhagen, Department of Geosciences and Natural Resource Management

³Ministry of Energy, Utilities and Climate

⁴Danish Business Authority

⁵Statistics Greenland

⁶Umhvørvisstovan (The Environment Agency, the Faroe Islands)



Data sheet

Series title and no.:	Scientific Report from DCE – Danish Centre for Environment and Energy No. 494
Category:	Scientific advisory report
Title:	Denmark's National Inventory Report 2022
Subtitle:	Emission Inventories 1990-2020 - Submitted under the United Nations Framework Convention on Climate Change and the Kyoto Protocol
Authors:	Ole-Kenneth Nielsen ¹ , Marlene S. Plejdrup ¹ , Morten Winther ¹ , Malene Nielsen ¹ , Steen Gyldenkærne ¹ , Mette Hjorth Mikkelsen ¹ , Rikke Albrektsen ¹ , Marianne Thomsen ¹ , Katja Hjelgaard ¹ , Patrik Fauser ¹ , Henrik G. Bruun ¹ , Vivian Kvist Johannsen ² , Thomas Nord-Larsen ² , Lars Vesterdal ² , Inge Stupak ² , Niclas Scott-Bentsen ² , Erik Rasmussen ³ , Susanne Bødtker Petersen ⁴ , Lene Baunbæk ⁵ , Maria Gunnleivsdóttir Hansen ⁶
Institutions:	¹ Aarhus University, Department of Environmental Science, ² University of Copenhagen, Department of Geosciences and Natural Resource Management, ³ Ministry of Energy, Utilities and Climate, ⁴ Danish Business Authority, ⁵ Statistics Greenland, ⁶ Umhøvrisstovan (The Environment Agency, The Faroe Islands)
Publisher:	Aarhus University, DCE – Danish Centre for Environment and Energy ©
URL:	http://dce.au.dk/en
Year of publication:	April 2022
Editing completed:	April 2022
Financial support:	No external financial support
Please cite as:	Nielsen, O.-K., Plejdrup, M.S., Winther, M., Nielsen, M., Gyldenkærne, S., Mikkelsen, M.H., Albrektsen, R., Thomsen, M., Hjelgaard, K., Fauser, P., Bruun, H.G., Johannsen, V.K., Nord-Larsen, T., Vesterdal, L., Stupak, I., Scott-Bentsen, N., Rasmussen, E., Petersen, S.B., Baunbæk, L., & Hansen, M.G. 2022. Denmark's National Inventory Report 2022. Emission Inventories 1990-2020 - Submitted under the United Nations Framework Convention on Climate Change and the Kyoto Protocol. Aarhus University, DCE – Danish Centre for Environment and Energy, 969 pp. Scientific Report No. 494 http://dce2.au.dk/pub/SR494.pdf
	Reproduction permitted provided the source is explicitly acknowledged
Abstract:	This report is Denmark's National Inventory Report 2022, which serves as documentation for the Danish greenhouse gas inventories submitted to the European Union and the United Nations. The report contains information on Denmark's emission inventories for all years' from 1990 to 2020 for CO ₂ , CH ₄ , N ₂ O, HFCs, PFCs and SF ₆ .
Keywords:	Emission Inventory; UNFCCC; IPCC; CO ₂ ; CH ₄ ; N ₂ O; HFCs; PFCs; SF ₆
Layout:	Ann-Katrine Holme Christoffersen, Aarhus University, Department of Environmental Science
Front page photo:	Ann-Katrine Holme Christoffersen, Aarhus University, Department of Environmental Science (<i>Winter in Agerup, Denmark</i>)
ISBN:	978-87-7156-680-2
ISSN (electronic):	2244-9981
Number of pages:	969
Internet version:	The report is available in electronic format (pdf) at http://dce2.au.dk/pub/SR494.pdf

Table of Contents

List of abbreviations	9
Acknowledgements	11
Executive summary	12
ES.1 Background information on greenhouse gas inventories and climate change	12
ES.2 Summary of national emission and removal trends	14
ES.3 Overview of source and sink category emission estimates and trends	15
ES.4 Other information	17
Sammenfatning	19
S.1 Baggrund for opgørelse af drivhusgasemissioner og klimacændringer	19
S.2 Udviklingen i drivhusgasemissioner og optag	21
S.3 Oversigt over drivhusgasemissioner og optag fra sektorer	22
S.4 Andre informationer	24
1 Introduction	26
1.1 Background information on greenhouse gas inventories and climate change	26
1.2 A description of the institutional arrangement for inventory preparation	29
1.3 Brief description of the process of inventory preparation. Data collection and processing, data storage and archiving	31
1.4 Brief general description of methodologies and data sources used	34
1.5 Brief description of key categories	42
1.6 Information on QA/QC plan including verification and treatment of confidential issues where relevant	45
1.7 General uncertainty evaluation, including data on the overall uncertainty for the inventory totals	60
1.8 General assessment of the completeness	66
1.9 ETS emissions	66
1.10 References	67
2 Trends in greenhouse gas emissions	70
2.1 Description and interpretation of emission trends for aggregated greenhouse gas emissions	70
2.2 Description and interpretation of emission trends by gas	71
2.3 Description and interpretation of emission trends by source	73
2.4 Description and interpretation of emission trends for KP-LULUCF inventory in aggregate, by activity and by gas	75
3 Energy	78
3.1 Overview of the sector	78
3.2 Stationary combustion	83

3.3	Transport and other mobile sources	175
3.4	Additional information, CRF sector 1A Fuel combustion	279
3.5	Fugitive emissions (CRF sector 1B)	285
4	Industrial Processes and Product Use	317
4.1	Overview of the sector	317
4.2	Mineral Industry	320
4.3	Chemical Industry	338
4.4	Metal industry	342
4.5	Non-Energy Products from Fuels and Solvent Use	347
4.6	Electronics Industry	355
4.7	Product Uses as Substitutes for Ozone Depleting Substances (ODS)	357
4.8	Other Product Manufacture and Use	368
4.9	Uncertainty	377
4.10	Quality assurance/quality control (QA/QC)	380
4.11	Recalculations	387
4.12	Improvements	388
4.13	References	390
5	Agriculture	396
5.1	Overview of sector	396
5.2	Data sources	400
5.3	Enteric fermentation	405
5.4	Manure management – CH ₄	412
5.5	Manure management – N ₂ O	418
5.6	Agricultural soils – direct N ₂ O emissions	421
5.7	Agricultural soils –indirect N ₂ O emissions	429
5.8	Field burning of agricultural residues	432
5.9	CO ₂ from liming	433
5.10	CO ₂ from urea	434
5.11	CO ₂ from other carbon-containing fertilisers	435
5.12	Uncertainties	436
5.13	Quality assurance and quality control (QA/QC)	438
5.14	Recalculations	452
5.15	Category-specific improvements	458
5.16	Planned improvements	459
5.17	References	460
6	LULUCF	465
6.1	Overview of the sector	465
6.2	Forest land (4A)	474
6.3	Cropland (4B)	488
6.4	Grassland (4C)	506
6.5	Wetlands (4D)	510
6.6	Settlements (4E)	514
6.7	Other Land (4F)	516
6.8	Direct N ₂ O emissions from N fertilization of Forest Land and Other Land use	517
6.9	Emissions and removals from drainage and rewetting and other management of organic and mineral soils	517

6.10	Direct nitrous oxide (N ₂ O) emissions from nitrogen (N) mineralization/immobilization associated with loss/gain of soil organic matter	518
6.11	Biomass burning	519
6.12	Harvested Wood Products (HWP)	520
6.13	QA/QC plan	521
6.14	Category-specific improvements	528
6.15	References	531
7	Waste	537
7.1	Overview of the sector	537
7.2	Solid waste disposal	540
7.3	Biological treatment of solid waste	551
7.4	Incineration and open burning	559
7.5	Wastewater treatment and discharge	564
7.6	Other	574
7.7	Uncertainties and time series consistency	581
7.8	QA/QC and verification	585
7.9	Source specific recalculations	592
7.10	Source specific improvements	594
7.11	References	601
8	Other	616
9	Recalculations and improvements	617
9.1	Explanations and justifications for recalculations	617
9.2	Implications for emission levels	617
9.3	Implications for emission trends, including time series consistency	618
9.4	Recalculations, including those in response to the review process, and planned improvements to the inventory (e.g. institutional arrangements, inventory preparations)	625
9.5	Explanations, justifications and implications of recalculations for KP-LULUCF inventory	626
10	KP-LULUCF	627
10.1	General information	627
10.2	Land-related information	632
10.3	Afforestation, Reforestation & Deforestation (ARD)	633
10.4	Forest Management (FM)	635
10.5	Forest Management Reference level (FMRL)	636
10.6	Cropland Management (CM)	637
10.7	Grazing land management (GM)	638
10.8	Article 3.3	639
10.9	Article 3.4	640
10.10	Harvested Wood Products	641
10.11	Other information	641
10.12	Information relating to Article 6	642
10.13	References	642
11	Indirect CO₂ and N₂O emissions	643
11.1	Description of sources of indirect emissions in GHG inventory	643

11.2	Methodological issues	643
11.3	Uncertainties and time-series consistency	644
11.4	Category-specific QA/QC and verification	645
11.5	Category-specific recalculations	645
11.6	Category-specific planned improvements	646
11.7	References	646
12	Information on accounting of Kyoto units	647
12.1	Information on transferred or acquired units	647
12.2	Summary of information reported in the SEF tables	647
12.3	Discrepancies and notifications	647
12.4	Publicly accessible information	647
12.5	Calculation of the commitment period reserve	648
12.6	KP-LULUCF accounting	648
12.7	References	649
13	Information on changes in the national system	650
14	Information on changes in the National Registry	651
15	Information on the minimization of adverse impacts in accordance with Article 3, paragraph 14	653
16	Methodology applied for the greenhouse gas inventory for Greenland	654
16.1	Introduction	654
16.2	Trends in Greenhouse Gas Emissions	667
16.3	Energy (CRF sector 1)	675
16.4	Industrial Processes and Product Use (CRF sector 2)	699
16.5	Agriculture (CRF sector 3)	719
16.6	LULUCF (CRF sector 4)	739
16.7	Waste (CRF sector 5)	750
16.8	Other	767
16.9	Recalculations and improvements	767
16.10	KP-LULUCF	767
16.11	Annex 1 Key categories	773
16.12	Annex 2 Detailed discussion of methodology and data for estimating CO ₂ emission from fossil fuel combustion	778
16.13	Annex 3 Other detailed methodological descriptions for individual source or sink categories	779
16.14	Annex 4 CO ₂ reference approach and comparison with sectoral approach, and relevant information on the national energy balance	779
16.15	Annex 5 Assessment of completeness and (potential) sources and sinks of greenhouse gas emissions and removals excluded	779
16.16	Annex 6 Additional information to be considered as part of the annual inventory submission and the supplementary information required under Article 7, paragraph 1, of the Kyoto Protocol or other useful reference information	780
16.17	Annex 7 Tables 6.1 and 6.2 of the IPCC good practice guidance	781

16.18 Annex 8 Results of a technical analysis conducted on the Greenlandic gasoil	783
17 Information regarding the aggregated submission for Denmark and Greenland	784
17.1 Trends in emissions	784
17.2 The reference approach	784
17.3 Uncertainties	784
17.4 Key category analysis	790
17.5 Recalculations	796
17.6 Technical description of the aggregation of the emission inventories of Denmark and Greenland	796
17.7 QA/QC of the aggregated submission for Denmark and Greenland	796
Annexes	799
Annex 1 - Key category analysis	800
Annex 2 - Assessment of uncertainty	817
Annex 3 - Other detailed methodological descriptions for individual source or sink categories (where relevant)	818
Annex 4 - Information on the energy statistics	898
Annex 5 - Assessment of completeness and (potential) sources and sinks of greenhouse gas emissions and removals excluded	907
Annex 6 - Additional information to be considered as part of the annual inventory submission and the supplementary information required under Article 7, paragraph 1, of the Kyoto Protocol or other useful reference information	908
Annex 7 - Information related to the greenhouse gas inventory for the Faroe Islands	916
Annex 8 - Key category analysis for Denmark and Greenland	761
Annex 9 - Comparison of fuel data from Eurostat and CRF	962

List of abbreviations

BAT	Best Available Techniques
CH ₄	Methane
CHP	Combined Heat and Power
CHR	Central Husbandry Register
CLRTAP	Convention on Long-Range Transboundary Air Pollution
CO	Carbon monoxide
CO ₂	Carbon dioxide
COPERT	COMputer Programme to calculate Emissions from Road Transport
CORINAIR	CORe INventory on AIR emissions
CRF	Common Reporting Format
DAAS	Danish Agricultural Advisory Service
DAFA	Danish AgriFish Agency
DCA	Danish Centre for food and Agriculture
DCE	Danish Centre for Environment and energy
DEA	Danish Energy Agency
DEPA	Danish Environmental Protection Agency
DST	Statistics Denmark
EEA	European Environment Agency
EF	Emission Factor
EIONET	European Environment Information and Observation Network
EMEP	European Monitoring and Evaluation Programme
ENVS	Department of ENVironmental Science, Aarhus University
EU ETS	European Union Emission Trading Scheme
FSE	Full Scale Equivalent
GE	Gross Energy
GHG	Greenhouse gas
GWP	Global Warming Potential
HFCs	Hydrofluorocarbons
IDA	Integrated Database model for Agricultural emissions
IEF	Implied Emission Factor
IGN	Department of Geosciences and Natural Resource Management, Copenhagen University
IPCC	Intergovernmental Panel on Climate Change
KCA	Key Category Analysis
LPG	Liquefied Petroleum Gas
LRTAP	Long-Range Transboundary Air Pollution
LTO	Landing and Take Off
LULUCF	Land Use, Land-Use Change and Forestry
MCF	Methane Conversion Factor
MSW	Municipal Solid Waste
N ₂ O	Nitrous oxide
NF ₃	Nitrogen trifluoride
NFI	National Forest Inventory
NFR	Nomenclature For Reporting
NH ₃	Ammonia
NIR	National Inventory Report
NMVOC	Non-Methane Volatile Organic Compounds
NO _x	Nitrogen Oxides
PFCs	Perfluorocarbons
QA	Quality Assurance

QC	Quality Control
SCR	Selective Catalytic Reduction
SF ₆	Sulphur hexafluoride
SNAP	Selected Nomenclature for Air Pollution
SO ₂	Sulphur dioxide
SWDS	Solid Waste Disposal Sites
UNECE	United Nations Economic Commission for Europe
UNFCCC	United Nations Framework Convention on Climate Change
VS	Volatile Solids
WWTP	WasteWater Treatment Plant

Executive summary

ES.1 Background information on greenhouse gas inventories and climate change

ES.1.1 Reporting

This report is Denmark's National Inventory Report (NIR) 2022 for submission to the United Nations Framework Convention on Climate Change due April 15, 2022. The report contains detailed information about Denmark's inventories for all years from 1990 to 2020. The structure of the report is in accordance with the UNFCCC reporting guidelines (UNFCCC, 2013). The main difference between Denmark's NIR 2022 report to the European Commission, due March 15, 2022 and the report to UNFCCC, is reporting of territories. The NIR 2022 to the EU Commission is for Denmark, while the NIR 2022 to the UNFCCC is for Denmark, Greenland and the Faroe Islands. The report includes detailed and complete information on the inventories for all years from year 1990 to the year 2020, in order to ensure transparency.

The annual emission inventories for the years from 1990 to 2020 are reported in the Common Reporting Format (CRF). Within this submission separate CRF's are available for Denmark (EU and KP - CP2), Greenland, the Faroe Islands, for Denmark and Greenland (KP - CP1) as well as for Denmark, Greenland and the Faroe Islands (UNFCCC). The CRF spreadsheets contain data on emissions, activity data and implied emission factors for each year. Emission trends are given for each greenhouse gas and for total greenhouse gas emissions in CO₂ equivalents.

The issues addressed in this report are: Trends in greenhouse gas emissions, description of each emission category of the CRF, uncertainty estimates, explanations on recalculations, planned improvements and procedure for quality assurance and control. The information presented in Chapters 2-9 and Chapter 11 refers to Denmark (EU and KP - CP2) only. Specific information regarding the submission of Greenland and the Faroe Islands is included in Chapter 16 and Annex 8, respectively. Chapter 17 contains information on the aggregated submission of Denmark and Greenland under the Kyoto Protocol (e.g. on trends, uncertainties and key category analysis).

This report itself does not contain the full set of CRF tables. The full set of CRF tables is available at the EIONET, Central Data Repository, kept by the European Environmental Agency:

http://cdr.eionet.europa.eu/dk/Air_Emission_Inventories

In the report, English notation is used: "." (full stop) for decimal sign and mostly space for division of thousands. The English notation for division of thousand as "," (comma) is not used due to the risk of being misinterpreted by Danish readers.

ES.1.2 Institutions responsible

On behalf of the Ministry of the Environment and Food and the Ministry of Energy, Utilities and Climate, the Danish Centre for Environment and Energy (DCE), Aarhus University, is responsible for the calculation and reporting of the Danish national emission inventory to EU, the UNFCCC (United Nations Framework Convention on Climate Change) and the UNECE LRTAP

(Long Range Transboundary Air Pollution) conventions. Hence, DCE prepares and publishes the annual submission for Denmark to the EU and UNFCCC of the National Inventory Report and the greenhouse gas (GHG) inventories in the Common Reporting Format, in accordance with the UNFCCC guidelines. Further, DCE is responsible for reporting the national inventory for the Kingdom of Denmark to the UNFCCC. DCE is also the body designated with overall responsibility for the national inventory under the Kyoto Protocol for Greenland and Denmark. Furthermore, DCE participates when reporting issues are discussed in the regime of UNFCCC and EU (Monitoring Mechanism).

The work concerning the annual greenhouse gas emission inventory is carried out in cooperation with Danish ministries, research institutes, organisations and companies. The Government of Greenland is responsible for finalising and transferring the inventory for Greenland to DCE. The Faroe Islands Environmental Agency is responsible for finalising and transferring the inventory for the Faroe Islands to DCE.

ES.1.3 Greenhouse gases

The greenhouse gases reported are those under the UN Climate Convention:

- Carbon dioxide CO₂
- Methane CH₄
- Nitrous oxide N₂O
- Hydrofluorocarbons HFCs
- Perfluorocarbons PFCs
- Sulphur hexafluoride SF₆
- Nitrogen trifluoride NF₃

The global warming potential (GWP) for various greenhouse gases has been defined as the warming effect over a given time frame of a given weight of a specific substance relative to the same weight of CO₂. The purpose of this measure is to be able to compare and integrate the effects of the individual greenhouse gases on the global climate. Typical lifetimes in the atmosphere of greenhouse gases are very different, e.g. approximately 12 and 109 years for CH₄ and N₂O, respectively. So the time perspective clearly plays a decisive role. The life frame chosen is typically 100 years. The effect of the various greenhouse gases can then be converted into the equivalent quantity of CO₂, i.e. the quantity of CO₂ giving the same effect in absorbing solar radiation. According to the IPCC and their Fourth Assessment Report, which UNFCCC has decided to use as reference, the global warming potentials for a 100-year time horizon are:

- Carbon dioxide (CO₂): 1
- Methane (CH₄): 25
- Nitrous oxide (N₂O): 298

Based on weight and a 100-year period, CH₄ is thus 25 times more powerful a greenhouse gas than CO₂ and N₂O is 298 times more powerful than CO₂. Some of the other greenhouse gases (hydrofluorocarbons, perfluorocarbons and sulphur hexafluoride) have considerably higher global warming potentials. For example, sulphur hexafluoride has a global warming potential of 22 800. The values for global warming potential used in this report are those prescribed by UNFCCC. The indirect greenhouse gases reported are nitro-

gen oxides (NO_x), carbon monoxide (CO), non-methane volatile organic compounds (NMVOC) and sulphur dioxide (SO₂).

ES.2 Summary of national emission and removal trends

Summary ES.2-4 refers to the inventory for Denmark only. The inventories for Greenland, Denmark and Greenland and the Faroe islands are described in Chapter 16 and 17 and Annex 8, respectively. The emissions from Greenland and the Faroe Islands are minor compared to the emissions from Denmark and shows limited fluctuations.

ES.2.1 Greenhouse gas emissions inventory

The greenhouse gas emissions are estimated according to the IPCC guidelines and are aggregated into five main sectors. The greenhouse gases include CO₂, CH₄, N₂O, HFCs, PFCs, SF₆ and NF₃. Figure ES.1 shows the estimated total greenhouse gas emissions in CO₂ equivalents from 1990 to 2020. The emissions are not corrected for electricity trade or temperature variations.

CO₂ is the most important greenhouse gas contributing in 2020 to the national total in CO₂ equivalents excluding LULUCF (Land Use and Land Use Change and Forestry) and excluding indirect CO₂ emissions with 68.1%, followed by CH₄ with 17.1 %, N₂O with 13.8 %, and f-gases (HFCs, PFCs, SF₆ and NF₃) with 0.9 %. The energy sector and agricultural sector represent the largest sources, followed by industrial processes and product use and waste, see Figure 1. The total national greenhouse gas emission in CO₂ equivalents excluding LULUCF has decreased by 41.3 % from 1990 to 2020 when considering indirect CO₂, if excluding indirect CO₂ the emissions have decreased by 40.7 %. The emissions including LULUCF and indirect CO₂ have decreased by 42.5 % from 1990 to 2020.

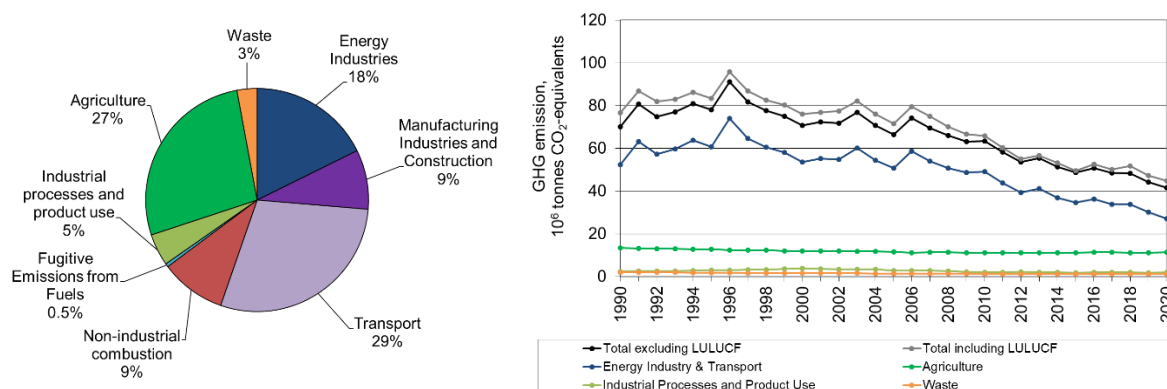

Figure ES.1 Greenhouse gas emissions in CO₂ equivalents distributed on main sectors for 2020 (excluding LULUCF and indirect CO₂) and time series for 1990 to 2020.

ES.2.2 KP-LULUCF activities

Table ES.1 contains information on emissions/removals of greenhouse gases in 2020.

Table ES.1 Emissions and removals in 2020 for activities relating to Article 3.3 and Article 3.4.

	Net CO ₂ emissions/ removals	CH ₄	N ₂ O	Net CO ₂ equivalents emissions/ removals
kt				
A. Article 3.3 activities				239.69
A.1. Afforestation and Reforestation	-283.51	0.04	0.02	-274.99
A.2. Deforestation	211.74	0.03	1.01	514.67
B. Article 3.4 activities				4065.94
B.1. Forest Management	-981.70	0.10	0.11	-945.42
B.2. Cropland Management	2656.03	3.85	0.02	2756.71
B.3. Grazing Land Management	2054.39	7.92	0.01	2254.65
B.4. Revegetation	NA	NA	NA	NA
B.5. Wetland drainage and rewetting	NA	NA	NA	NA

ES.3 Overview of source and sink category emission estimates and trends

ES.3.1 Greenhouse gas emissions inventory

Energy

The emission from the energy sector in 2020 covers 65.3 % of the total emission in CO₂ equivalents (excl. LULUCF and indirect CO₂). The emission of CO₂ equivalents from energy industries (CRF 1A1) has decreased by 72.0 % from 1990 to 2020. The relatively large fluctuations in the emission through the time-series 1990-2020 is due to inter-country electricity trade. Thus, the high emissions in 1991, 1996, 2003 and 2006 reflect a large electricity export and the low emission in 1990, 2005, 2008, 2011 and 2012 is due to import of electricity. In general, CO₂ emissions are decreasing due to a lower consumption of fossil fuels and a higher electricity production based on renewable energy, mainly wind power.

The increasing emission of CH₄ is due to the increasing use of gas engines in decentralised cogeneration plants. However, in later years the CH₄ emission has decreased due to less use of natural gas in gas engines. The CH₄ emission from residential combustion (mainly wood) increased as a result of increased use of wood. However, the wood consumption has decreased substantially over the last years, so that emission is decreasing. The emission of CO₂ equivalents from the transport sector (CRF 1A3) increased by 11.5 % from 1990 to 2020, mainly due to increasing road traffic. A large decrease in transport emissions occurred between 2019 and 2020, which can to a large extent be attributed to the restrictions to mobility in battling the COVID-19 pandemic.

Industrial processes and product use

The emissions from industrial processes and product use, i.e. emissions from processes other than fuel combustion, amount in 2020 to 4.6 % of the total emission in CO₂ equivalents (excl. LULUCF and indirect CO₂). The main sources are cement production and f-gases used in refrigeration and air conditioning.

The largest source is CO₂ emission from cement production, which in 2020 contributes with 1227.0 kt CO₂, i.e. 3.0 % of the national greenhouse gas emissions. The CO₂ emission from cement production has increased by 39.0 % since 1990. The second largest source is the emission from consumption of HFCs mainly from refrigeration and air condition equipment. This source contributes with 334.6 kt CO₂ equivalents, i.e. 0.8 % of the national total. Historically (1990-2004), the emission of N₂O from the production of nitric acid has been the second largest source (after cement), with up to 1002.5 kt CO₂ equivalents (1990). However, the production of nitric acid ceased in 2004, which reduced the N₂O emission from industrial processes drastically.

Agriculture

The agricultural sector contributes in 2020 with 27.1 % of the total emission in CO₂ equivalents (excl. LULUCF and indirect CO₂) and the major part is related to the livestock production. Since 1990, the agricultural emission has decreased 15.5 % mainly due to a decrease in the N₂O emission.

In 2020, the agricultural activities accounts for 82.6 % of the total CH₄ emission (excl. LULUCF). Since 1990, the emission of CH₄ from enteric fermentation has decreased by 8.9 %, which is mainly due to the decrease in the number of dairy cattle. However, the emission from manure management has in the same period increased 18.5 %, which is mainly driven by a change from traditional housing systems towards slurry-based housing systems. In total, the CH₄ emission from the agriculture sector 1990 – 2020 has decreased 0.3 %.

In 2020, the agricultural activities accounts for 89.6 % of the total N₂O emission (excl. LULUCF). Since 1990, the N₂O emission has decreased 24.8 %. A string of measures have been introduced by action plans to prevent the loss of nitrogen from agriculture to the aquatic environment. These actions have brought a decrease in animal nitrogen excretion, improvement in use of nitrogen in manure and a fall in the use of inorganic N fertiliser, which all have led to reductions of the N₂O emission.

Land Use and Land Use Change and Forestry (LULUCF)

The total sector has been estimated to be a net source of 4.3 % of the total Danish emission incl. LULUCF (average 2013-2020 (variation 1.6-7.2 % depending of year). The average emission in 2013-2020 has been estimated to 2145 kt CO₂ equivalents with an emission of 3107 kt CO₂ equivalents in 2020. Emissions/removals from the sector fluctuate based on specific conditions in the given year. In general, the forest sector is a net sink or around in its equilibrium state, while Cropland and Grassland are net sources. The latter due to a large area with drained organic soils. Emissions from drained organic agricultural soils in 2020 accounts for 9.9 % of the total Danish emission incl. LULUCF. Forest has shown to be a sink for all years since 1990. Since 2013, forest has been estimated to be an average annual net sink of 2980 kt CO₂ equivalents.

In 2020, Cropland has been estimated to be a net source of 6.4 % of the total Danish emission incl. LULUCF. Grassland is a net source contributing to 5.0 % of the total Danish emission, also due to a large area with drained organic soils. Emissions from Cropland and Grassland have shown a continuous decrease since 1990. However, large variations occur between years.

Waste

The waste sector contributes in 2020 to 2.9 % of the total emission in CO₂ equivalents (excl. LULUCF and indirect CO₂). The emission from the sector has decreased by 36.2 % since 1990. The most important activity in the sector is solid waste disposal on land with CH₄ emissions contributing in 2020 to 44.4 % of the sectoral total GHG emission.

The CH₄ emission from solid waste disposal has been decreasing since 1990 by 65.1 % due to banning of depositing organic waste and an overall decrease in waste deposited because waste has increasingly been used for power and heat production and/or recycled.

Biological treatment of solid waste (5.B) is the second largest contributor to the sectoral total GHG emission in 2020. It contributes to the sectoral total in CO₂ equivalents in 2020 with 37.0 %. The emissions from biological treatment of solid waste have increased by 1059 % for CH₄ and 228 % for N₂O since 1990, due to an increase in the number of biogas plants and the amount of biowaste composted in Denmark.

Wastewater handling contributes to the sectoral total in CO₂ equivalents in 2020 with 16.5 %. The CH₄ emissions from wastewater handling have increased by 28.7 % from 1990 to 2020 while the N₂O emission has decreased by 38.6 %.

Since all incinerated waste (municipal, industrial, hazardous) is used for power and heat production, the emissions are included in the 1A1a category.

ES.3.2 KP-LULUCF activities

A more detailed description is given in Chapter 10.

ES.4 Other information

ES.4.1 Quality assurance and quality control

A plan for Quality Assurance (QA) and Quality Control (QC) in greenhouse gas emission inventories is included in the report. The plan is in accordance with the guidelines provided by the UNFCCC (Good Practice Guidance and Uncertainty Management in National Greenhouse Gas Inventories and Guidelines for National Systems). ISO 9000 standards are also used as an important input for the plan.

The plan comprises a framework for documenting and reporting emissions in a way that emphasize transparency, consistency, comparability, completeness and accuracy. To fulfil these high criteria, the data structure describes the pathway, from the collection of raw data to data compilation and modelling and finally reporting.

As part of the Quality Assurance (QA) activities, emission inventory sector reports are being prepared and sent for review to national experts not involved in the inventory development. To date, the reviews have been completed for the stationary combustion plants sector, the fugitive emissions from fuels sector, the transport sector, the solvents and other product use sector and the agricultural sector. In order to evaluate the Danish emission inventories, a project where emission levels and emission factors are compared with those in other countries has been conducted.

ES.4.2 Completeness

The Danish greenhouse gas emission inventories include all sources identified by the revised IPCC guidelines.

Please see Annex 5 for more information.

ES.4.3 Recalculations and improvements

Recalculations and improvements are continuously made to the inventory. The sector-specific recalculations and improvements are documented in the sectoral chapters of this report (Chapter 3-7) and a general overview is provided in Chapter 9.

Sammenfatning

S.1 Baggrund for opgørelse af drivhusgasemissioner og klimacændringer

S.1.1 Rapporteringen

Denne rapport er Danmarks årlige rapport – den såkaldte Nationale Inventory Report (NIR) for 2022. Rapporten beskriver drivhusgasopgørelsen som blev fremsendt til FN's konvention om klimacændringer (UNFCCC) og Kyoto-protokollen den 15. april 2022. Rapporten indeholder detaljerede informationer om Danmarks drivhusgasudslip for alle år fra 1990 til 2020. Rapportens struktur er i overensstemmelse med UNFCCC's retningslinjer for rapportering. Forskellen mellem Danmarks NIR 2022 som blev fremsendt til EU-Kommissionen den 15. marts 2022 og denne rapport til UNFCCC, vedrører det territorium rapporteringen omfatter. NIR 2022 til EU-Kommissionen omfatter Danmark, mens NIR 2022 til UNFCCC omfatter Danmark, Grønland og Færøerne. For at sikre at opgørelserne er sammenhængende og gennemskuelige, indeholder rapporten detaljerede oplysninger om opgørelsesmetoder og baggrundsdata for alle årene fra 1990 og til 2020.

Denne emissionsopgørelse for årene 1990 til 2020, er som tidligere årlige opgørelser, rapporteret i formatet Common Reporting Format (CRF) som Klimakonventionen foreskriver anvendt. Emissionsopgørelsen i CRF foreligger med denne rapportering således, at der er separate CRF for Danmark (EU og KP – CP2), Grønland, Færøerne, for Danmark og Grønland (KP – CP1) samt for Danmark, Grønland og Færøerne (Klimakonventionen). CRF-tabellerne indeholder oplysninger om emissioner, aktivitetsdata og emissionsfaktorer for hvert år, emissionsudvikling for de enkelte drivhusgasser samt den totale drivhusgasemission i CO₂-ækvivalenter.

Følgende emner er beskrevet i rapporten: Udviklingen i drivhusgasemissionerne, metoder mv. som anvendes til opgørelserne i de emissionskategorier som findes i CRF-formatet, usikkerheder, genberegninger, planlagte forbedringer og procedure for kvalitetssikring og -kontrol. Teksten i kapitel 2-9 og kapitel 11 omhandler kun Danmark som omfattet af EU. Oplysninger om emissionsopgørelsen for Grønland og Færøerne er inkluderet i henholdsvis kapitel 16 og annek 8. Kapitel 17 indeholder informationer for den samlede aflevering for Danmark og Grønland under Kyoto-protokollen (f.eks. om udviklingen i emissioner over tid, usikkerheder og identifikation af nøglekategorier).

Denne rapport indeholder ikke det fulde sæt af CRF-tabeller. Det fulde sæt af CRF-tabeller er tilgængelige på EIONET, som er det Europæiske Miljøagenturs rapporterings-internetsite:

http://cdr.eionet.europa.eu/dk/Air_Emission_Inventories

Med hensyn til gengivelsen af tal i CRF-formatet, gøres opmærksom på at det er med dansk notation: “,” (komma) for decimaladskillelse og “.” (punktum) til adskillelse af tusinder. I rapporten er den engelske notation brugt: “.” (punktum) for decimaltegn og for det meste mellemrum for adskillelse af tusinder. Den engelske notation for adskillelse af tusinder med “,” (komma) er for det meste ikke brugt på grund af risikoen for fejltolkninger for danske læsere.

S.1.2 Ansvarlige institutioner

DCE - Nationalt Center for Miljø og Energi ved Aarhus Universitet er på vegne af Miljø- og Fødevarerministeriet samt Energi-, Forsynings- og Klimaministeriet ansvarlig for udregning og afrapportering af den nationale emissionsopgørelse til EU og til UNFCCC (FN's konvention om klimaændringer) såvel som til UNECE-konventionen om langtransporteret grænseoverskridende luftforurening. Som følge heraf, er DCE ansvarlig for udførelse og publicering af opgørelserne af drivhusgasemissioner og den årlige rapportering til EU og UNFCCC for Danmark. DCE er den centrale institution for Danmarks nationale system til drivhusgasopgørelser under Kyotoprotokollen. Ydermere er DCE ansvarlig for rapportering af drivhusgasemissionsopgørelser til Klimakonventionen for Kongeriget Danmark (Færøerne, Grønland og Danmark), samt Danmarks og Grønlands samlede rapportering til Kyotoprotokollen. DCE deltager desuden i arbejdet i regi af Klimakonventionen og Kyotoprotokollen, hvor retningslinjer for rapportering diskuteres og vedtages og i EU's monitoringsmekanisme for opgørelse af drivhusgasser, hvor retningslinjer for rapportering til EU reguleres.

Arbejdet med de årlige opgørelser udføres i samarbejde med andre danske ministerier, forskningsinstitutioner, organisationer og private virksomheder. Grønlands Klima- og Infrastrukturstyrelse er ansvarlig for levering af opgørelser for Grønland til DCE. Færøernes miljømyndighed (Umhvørvisstovan) er ansvarlig for de færøske opgørelser.

S.1.3 Drivhusgasser

Til Klimakonventionen rapporteres følgende drivhusgasser:

- Kuldioxid CO_2
- Metan CH_4
- Lattergas N_2O
- Hydrofluorcarboner HFC'er
- Perfluorcarboner PFC'er
- Svovlhexafluorid SF_6
- Nitrogentrifluorid NF_3

Det globale opvarmningspotentiale, på engelsk Global Warming Potential (GWP), udtrykker klimapåvirkningen over en nærmere angivet tid af en vægtenhed af en given drivhusgas relativt til samme vægtenhed af CO_2 . Drivhusgasser har forskellige karakteristiske levetider i atmosfæren, således for CH_4 ca. 12 år og for N_2O ca. 109 år. Derfor spiller tidshorisonten en afgørende rolle for størrelsen af GWP. Typisk vælges 100 år. Herefter kan effekten af de forskellige drivhusgasser omregnes til en ækvivalent mængde CO_2 , dvs. til den mængde CO_2 der vil give samme klimapåvirkning. Til rapporteringen til Klimakonventionen er vedtaget at anvende GWP-værdier for en 100-årig tidshorisont, som ifølge IPCC's fjerde vurderingsrapport er:

- Kuldioxid, CO_2 : 1
- Metan, CH_4 : 25
- Lattergas, N_2O : 298

Regnet efter vægt og over en 100-årig periode er metan således ca. 25 og lattergas ca. 298 gange så effektive drivhusgasser som kuldioxid. For andre drivhusgasser der indgår i rapporteringen, de såkaldte F-gasser (HFC, PFC, SF_6 , NF_3) findes væsentlig højere GWP-værdier. Under Klimakonventionen

er der ligeledes vedtaget GWP-værdier for disse baseret på IPCC's anbefalinger. Således har f.eks. SF₆ en GWP-værdi på 22 800. I denne rapport anvendes de GWP-værdier, som UNFCCC har vedtaget.

Endvidere rapporteres de indirekte drivhusgasser kvælstofilte (NO_x), kulilte (CO), ikke-metan flygtige organiske forbindelser (NMVOC) og svovldioxid (SO₂).

S.2 Udviklingen i drivhusgasemissioner og optag

Sammenfatning S.2.-4. omhandler alene opgørelsen for Danmark. Opgørelsen for Grønland, Danmark og Grønland samt for Færøerne beskrives i kapitel 16 og 17 samt i annex 8.

S.2.1 Drivhusgasemissionsopgørelse

De danske opgørelser af drivhusgasemissioner følger metoderne som beskrevet i IPCC's retningslinjer. Opgørelserne er opdelt i seks overordnede sektorer, 1. energi, 2. industrielle processer og produktanvendelse, 3. landbrug, 4. arealanvendelse (Land Use Land Use Change and Forestry: LULUCF), 5. affald og 6. andet. Drivhusgasserne omfatter CO₂, CH₄, N₂O og F-gasserne: HFC'er, PFC'er, SF₆ og NF₃. I figur S.1 ses de estimerede drivhusgasemissioner for Danmark i CO₂-ækvivalenter for perioden 1990 til 2020. Figuren viser Danmarks totale udledning med og uden LULUCF-sektoren (Land Use and Land Use Change and Forestry). Til venstre i figur S.1 ses det relative bidrag til Danmarks totale udledning (uden LULUCF) i 2020 for sektorerne 1-3 og 5. For sektor 1. energi er transport (hovedsagelig vejtransport) vist særskilt. Sektor 4. LULUCF indgår ikke i denne figur, da sektoren omfatter kilder, der bidrager med både optag og udledninger.

I overensstemmelse med retningslinjerne for opgørelserne er emissionerne ikke korrigerede for handel med elektricitet med andre lande og temperatursvingninger fra år til år.

CO₂ er den vigtigste drivhusgas og bidrager i 2020 med 68,1 % af den nationale totale udledning uden LULUCF-sektoren, efterfulgt af CH₄ med 17,1 % og N₂O med 13,8 %, mens HFC'er, PFC'er og SF₆ kun udgør 0,9 % af de totale emissioner uden LULUCF-sektoren. Set over perioden 1990-2020, har disse procenter været stigende for CH₄ og F-gasser og svagt faldende for N₂O. For CO₂, har procenterne fluktueret mere gennem perioden. Med hensyn til sektorerne (figur S.1) så bidrager energi ekskl. vejtransport (hovedsageligt stationære forbrændingsanlæg), transport og landbrug mest i 2020 (figur S.1). De nationale totale drivhusgasemissioner i CO₂-ækvivalenter inklusiv indirekte CO₂ er faldet med 41,3 % fra 1990 til 2020, hvis nettobidraget fra skovenes og jordernes udledninger og optag af CO₂ (LULUCF) ikke indregnes. Eksklusiv LULUCF og indirekte CO₂ er emissionen faldet med 40,7 %. Emissionen inklusiv LULUCF og indirekte CO₂ er faldet med 42,5 % mellem 1990 og 2020.

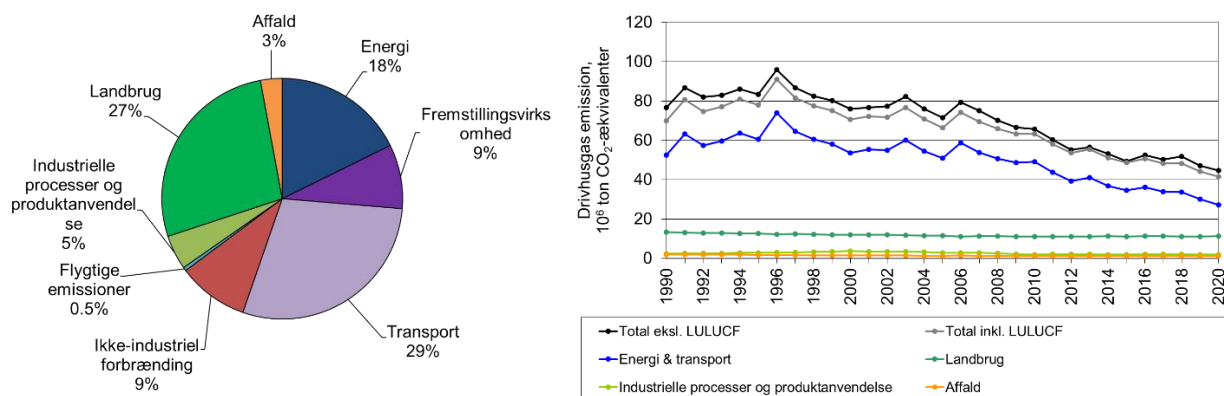

Figur S.1 Danske drivhusgasemissioner. Bidrag til total emission fra hovedsektorer for 2020 og tidsserier i CO₂-ækvivalenter for 1990-2020, hvor data er angivet med og uden LULUCF.

S.2.2 KP-LULUCF-aktiviteter

Tabel S.1 viser emissioner/optag fra LULUCF i 2020.

Tabel S.1 Emissioner og optag i 2020 for aktiviteter under Kyotoprotokollens artikel 3.3 og 3.4.

	Netto CO ₂ emission/ optag	CH ₄	N ₂ O	Netto CO ₂ -ækvivalent emission/optag
kt				
A. Aktiviteter under artikel 3.3				239.69
A.1. Skovrejsning	-283.51	0.04	0.02	-274.99
A.2. Skovrydning	211.74	0.03	1.01	514.67
B. Aktiviteter under artikel 3.4				4065.94
B.1. Forvaltning af skov plantet før 1990	-981.70	0.10	0.11	-945.42
B.2. Forvaltning af landbrugsarealer	2656.03	3.85	0.02	2756.71
B.3. Forvaltning af permanente græsarealer	2054.39	7.92	0.01	2254.65
B.4. Gentilplantning	NA	NA	NA	NA
B.5. Dræning og genetablering af vådområder	NA	NA	NA	NA

S.3 Oversigt over drivhusgasemissioner og optag fra sektorer

S.3.1 Drivhusgasemissionsopgørelse

Energi

Emissionen fra energisektoren udgjorde i 2019 65,3 % af den samlede drivhusgasemission udtrykt i CO₂-ækvivalenter (ekskl. LULUCF og indirekte CO₂). Drivhusgasemissionen from energisektoren (CRF 1A1) er faldet med 72,0 % fra 1990 til 2020. De relativt store udsving i emissionerne fra år til år skyldes handel med elektricitet med andre lande, herunder særligt de nordiske. De høje emissioner i 1991, 1996, 2003 og 2006 er et resultat af stor eksport af elektricitet, mens de lave emissioner i 1990, 2005, 2008, 2011 og 2012 skyldes import af elektricitet. Den væsentligste årsag til den faldende tendens er faldende fossilt brændselsforbrug, hovedsageligt for kul og naturgas.

Udledningen af CH₄ fra energiproduktion har været stigende på grund af øget anvendelse af gasmotorer, som har en stor CH₄-emission i forhold til andre forbrændingsteknologier. Anvendelsen af gasmotorer er dog blevet mindre siden liberaliseringen af elmarkedet, hvilket har ført til lavere CH₄-emissioner fra energisektoren. CH₄-emissionen fra husholdninger er steget på grund af et stigende forbrug af brænde i ovne og kedler. Fra 2016 er

træforbruget dog faldet væsentligt, hvilket har reduceret emissionen. Transportsektorens drivhusgasemissioner er steget med 11,5 % siden 1990 hovedsagelig på grund af voksende vejtrafik. Et betydeligt fald i emissionerne fra transport fandt sted mellem 2019 og 2020, hvilket i vid udstrækning kan tilskrives restriktioner i forbindelse med COVID-19 pandemien.

Industrielle processer og produktanvendelse

Emissionen fra industrielle processer og produktanvendelse – hvilket vil sige andre processer end forbrændingsprocesser – udgør i 2020 4,6 % af de totale danske drivhusgasemissioner. De vigtigste kilder er cementproduktion, og fluorerede gasser anvendt i kølesystemer.

CO₂-emissionen fra cementproduktion – som er den største kilde – bidrager med 1227,0 kt CO₂ svarende til 3,0 % af den totale emission i 2020. Emissionen fra cementproduktion er steget med 39,0 % siden 1990. Den anden største kilde er emission af HFCs i forbindelse med køling og aircondition. Denne kilde bidrog i 2020 med 334,6 kt CO₂-ækvivalenter svarende til 0,8 % af den nationale total. Tidligere (1990-2004) var den andenstørste kilde N₂O fra produktion af salpetersyre med op til 1002,5 kt CO₂-ækvivalenter (1990). Produktionen af salpetersyre stoppede i midten af 2004, hvilket betød, at N₂O-emissionen fra industrielle processer og produktanvendelse faldt drastisk.

Landbrug

Landbrugssektoren bidrager i 2020 med 27,1 % til den totale drivhusgasemission i CO₂-ækvivalenter og er den vigtigste sektor, hvad angår emissioner af N₂O og CH₄. Siden 1990 er drivhusgasemissionen fra landbruget faldet med 15,5 %. Faldet skyldes hovedsageligt et fald i emissionen af N₂O.

I 2020 bidrog landbruget med 82,6 % af den totale emission af CH₄. Siden 1990 er emissionen af CH₄ fra husdyrenes fordøjelsessystem faldet med 8,9 % grundet et faldende antal kvæg. Emissionen fra gødningshåndtering er dog i samme periode steget med 18,5 %. Dette skyldes, at der er sket en overgang fra traditionelle staldsystemer med fast gødning til flere gyllebaserede staldsystemer med højere emissioner. Samlet set er CH₄ emissionen fra landbrug faldet med 0,3 % siden 1990.

I 2020 bidrog landbruget med 89,6 % af den totale emission af N₂O. Siden 1990 er N₂O emissionen faldet med 24,8 %, hvilket skyldes en lang række virkemidler med formål at begrænse tabet af kvælstof til vandmiljøet. Dette har medført et fald i udskillelsen af kvælstof fra husdyr, bedre udnyttelse af kvælstoffet i husdyrgødningen samt et fald i anvendelsen af handelsgødning. Disse ting har alle ført til en reduceret emission af N₂O.

Arealanvendelse - skove og jorder (LULUCF)

Sektoren som helhed er estimeret til at være en nettoudledning på 4,3 % af den samlede danske emission inklusiv LULUCF (gennemsnit for 2013-2020, variation mellem 1,6 og 7,2 % afhængig af år). Den gennemsnitlige emission for perioden 2013-2020 er beregnet til 2145 kt CO₂-ækvivalenter med en emission på 3107 kt CO₂-ækvivalenter i 2020. Emissioner/optag fra sektoren fluktuerer baseret på de forhold (især klimatiske) i det enkelte år. Generelt har skov været et nettooptag, mens landbrugsjorde og græsarealer har været nettokilder. Grunden til at landbrug og græsarealer har været kilder er et betydeligt areal med drænede organiske jorde. Emissionen fra drænede organiske landbrugsjorde udgør 9,9 % af den samlede drivhusgasemission i 2020.

Siden 2013, har skov været et gennemsnitligt nettooptag på 2980 kt CO₂-ækvivalenter. I 2020 er landbrugsjorde opgjort til at være en kilde svarende til 6,4 % af den samlede danske drivhusgasemission. Græsarealer er opgjort til at være en kilde svarende til 5,0 % af den samlede danske drivhusgasemission. Emissioner fra landbrugsjorde og græsarealer er faldet stødt siden 1990, men med store variationer mellem år.

Affald

Affaldssektoren bidrager i 2020 med 2,9 % af den samlede drivhusgasemission eksklusiv LULUCF og indirekte CO₂. Emissionen fra sektoren er faldet med 36,2 % siden 1990. Den vigtigste aktivitet inden for sektoren er deponier, som står for 44,4 % af sektorens drivhusgasemissioner.

CH₄-emissionen fra deponier er faldet med 65,1 % siden 1990, hvilket skyldes et forbud mod deponering af forbrændingseget affald og et generelt fald i mængderne af deponeret affald pga. stigende affaldsforbrænding og genanvendelse.

Biologisk behandling af affald er den andenstørste kilde til affaldssektorens drivhusgasemissioner i 2020. Det bidrager med 37,0 % af sektorens emissioner i 2020. Emissionerne fra biologisk affaldsbehandling er steget kraftigt siden 1990 – CH₄ er steget med 1059 % og N₂O med 228 %. Dette skyldes den stigende popularitet af kompostering og biogasbehandling som affaldsbehandlingsmetoder.

Spildevandsbehandling bidrager til sektorens samlede emission med 16,5 % i 2020. CH₄-emissionen fra spildevandsbehandling er steget med 28,7 % siden 1990 mens N₂O-emissionen er faldet med 38,6 %.

Siden al affaldsforbrænding (husholdnings- og industriaffald samt farligt affald) udnyttes til produktion af varme og/eller elektricitet, så er emissionerne inkluderet under energisektoren, nærmere bestemt kategori 1A1a.

S.3.2 KP-LULUCF-aktiviteter

En mere detaljeret redegørelse findes i kapitel 10.

S.4 Andre informationer

S.4.1 Kvalitetssikring og -kontrol

Rapporten indeholder en plan for kvalitetssikring og -kontrol af emissionsopgørelserne. Kvalitetsplanen bygger på IPCC's retningslinjer og ISO 9000-standarderne. Planen skaber rammer for dokumentation og rapportering af emissionerne, så opgørelserne er gennemsikrede, konsistente, sammenlignelige, komplette og nøjagtige. For at opfylde disse kriterier, understøtter datastrukturen arbejdsgangen fra indsamling af data til sammenstilling, modellering og til sidst rapportering af data.

Som en del af kvalitetssikringen, udarbejdes der for emissionskilderne rapporter, der detaljeret beskriver og dokumenterer anvendte data og beregningsmetoder. Disse rapporter evalueres af personer uden for Aarhus Universitet, der har høj faglig ekspertise inden for det pågældende område, men som ikke direkte er involveret i arbejdet med opgørelserne. Indtil nu er rapporter for stationære forbrændingsanlæg, transport og landbrug blevet evalueret. Desuden er der gennemført et projekt, hvor de danske opgørelsesme-

toder, emissionsfaktorer og usikkerheder sammenlignes med andre landes, for yderligere at verificere rigtigheden af opgørelserne.

S.4.2 Fuldstændighed i forhold til IPCC's retningslinjer for kilder og gasser

De danske opgørelser af drivhusgasemissioner indeholder alle de kilder, der er beskrevet i IPCC's retningslinjer.

I annek 5 er der flere informationer om fuldstændigheden af den danske drivhusgasopgørelse.

S. 4.3 Genberegninger og forbedringer

Genberegninger og forbedringer bliver løbende udført i forbindelse med emissionsopgørelserne. De sektorspecifikke genberegninger og forbedringer er beskrevet i sektoraftsnittene i denne rapport (kapitel 3-7). Et generelt overblik er inkluderet i kapitel 9.

1 Introduction

1.1 Background information on greenhouse gas inventories and climate change

1.1.1 Annual report

This report is Denmark's National Inventory Report (NIR) 2022 for submission to the United Nations Framework Convention on Climate Change due April 15, 2022. The report contains detailed information about Denmark's inventories for all years from 1990 to 2020. The structure of the report is in accordance with the UNFCCC reporting guidelines (UNFCCC, 2013). The main difference between Denmark's NIR 2022 report to the European Commission, due March 15, 2022, and this report to UNFCCC is reporting of territories. The NIR 2022 to the EU Commission was for Denmark, while this NIR 2022 to the UNFCCC is for Denmark, Greenland and the Faroe Islands. The report includes detailed and complete information on the inventories for all years from year 1990 to the year 2020, in order to ensure transparency.

The information in the sectoral chapters in this report relates to Denmark only, while information for Greenland is included in Chapter 16 and for the Faroe Islands in Annex 7. Chapter 17 contains information (e.g. on trends, uncertainties and key category analysis) on the aggregated submission of Denmark and Greenland

The issues addressed in this report are trends in greenhouse gas emissions, a description of each IPCC category, uncertainty estimates, recalculations, planned improvements and procedures for quality assurance and control.

The annual emission inventories for the years from 1990 to 2020 are reported in the Common Reporting Format (CRF) as requested in the reporting guidelines. The CRF-spreadsheets contain data on emissions, activity data and implied emission factors for each year. Emission trends are given for each greenhouse gas and for the total greenhouse gas emissions in CO₂ equivalents.

According to the instrument of ratification, the Danish government has ratified the UNFCCC on behalf of Denmark, Greenland and the Faroe Islands. The Danish government has ratified the Kyoto Protocol on behalf of Denmark and Greenland. In the first commitment period under the Kyoto Protocol, Greenland had a reduction commitment. However, for the second commitment period, a territorial exemption for Greenland was made in the acceptance of the Doha Amendment; see C.N.773.2017.TREATIES-XXVII.7.c of 21 December 2017¹.

This report itself does not contain the full set of CRF Tables. The full set of CRF tables is available at the EIONET, Central Data Repository, kept by the European Environmental Agency:

http://cdr.eionet.europa.eu/dk/Air_Emission_Inventories/Submission_UNFCCC

¹ <https://treaties.un.org/doc/Publication/CN/2017/CN.773.2017-Eng.pdf>

1.1.2 Greenhouse gases

The greenhouse gases to be reported under the Climate Convention are:

- Carbon dioxide CO₂
- Methane CH₄
- Nitrous Oxide N₂O
- Hydrofluorocarbons HFCs
- Perfluorocarbons PFCs
- Sulphur hexafluoride SF₆
- Nitrogen trifluoride NF₃

The main greenhouse gas responsible for the anthropogenic influence on the heat balance is CO₂. The atmospheric concentration of CO₂ has increased from a pre-industrial value of about 278 ppm to about 410 ppm in 2019 (an increase of about 47 %) (IPCC, 2021), and exceeds the natural range of 180-300 ppm over the last 650 000 years as determined by ice cores. The main cause for the increase in CO₂ is the use of fossil fuels, but changing land use, including forest clearance, has also been a significant factor. The greenhouse gases CH₄ and N₂O are very much linked to agricultural production; CH₄ has increased from a pre-industrial atmospheric concentration of about 729 ppb to 1866 ppb in 2019 (an increase of about 156 %) and N₂O has increased from a pre-industrial atmospheric concentration of about 270 ppb to 332 ppb in 2019 (an increase of about 23 %) (IPCC, 2021). Changes in the concentrations of greenhouse gases are not related in simple terms to the effect on the heat balance, however. The various gases absorb radiation at different wavelengths and with different efficiency. This must be considered in assessing the effects of changes in the concentrations of various gases. Furthermore, the lifetime of the gases in the atmosphere needs to be taken into account – the longer they remain in the atmosphere, the greater the overall effect. The global warming potential (GWP) for various gases has been defined as the warming effect over a given time of a given weight of a specific substance relative to the same weight of CO₂. The purpose of this measure is to be able to compare and integrate the effects of individual substances on the global climate. Typical lifetimes in the atmosphere of substances are very different, e.g. 12 and 109 years approximately for CH₄ and N₂O, respectively (IPCC, 2021). Therefore, the time perspective clearly plays a decisive role. The time frame chosen is typically 100 years. The effect of the various greenhouse gases can, then, be converted into the equivalent quantity of CO₂, i.e. the quantity of CO₂ giving the same effect in absorbing solar radiation. According to the IPCC and their Fourth Assessment Report (IPCC, 2007), which UNFCCC (UNFCCC, 2013) has decided to use as reference for reporting for inventory years throughout the commitment period 2013-2020, the global warming potentials for a 100-year time horizon are:

- Carbon dioxide (CO₂): 1
- Methane (CH₄): 25
- Nitrous oxide (N₂O): 298

Based on weight and a 100-year period, methane is thus 25 times more powerful a greenhouse gas than CO₂, and N₂O is 298 times more powerful. Some of the other greenhouse gases (hydrofluorocarbons, perfluorocarbons and sulphur hexafluoride) have considerably higher global warming potential values. For example, sulphur hexafluoride has a global warming potential of 22 800.

The indirect greenhouse gases reported are nitrogen oxides (NO_x), carbon monoxide (CO), non-methane volatile organic compounds (NMVOC) and sulphur dioxide (SO₂).

1.1.3 The Climate Convention and the Kyoto Protocol

At the United Nations Conference on Environment and Development in Rio de Janeiro in June 1992, more than 150 countries signed the UNFCCC (the Climate Convention). On the 21st of December 1993, the Climate Convention was ratified by a sufficient number of countries, including Denmark, for it to enter into force on the 21st of March 1994. One of the provisions of the treaty was to stabilise the greenhouse gas emissions from the industrialised nations by the end of 2000. At the first conference under the UN Climate Convention in March 1995, it was decided that the stabilisation goal was inadequate. At the third conference in December 1997 in Kyoto in Japan, a legally binding agreement was reached committing the industrialised countries to reduce the six greenhouse gases by 5.2 % by 2008-2012 compared with the base year. For F-gases, the countries can choose freely between 1990 and 1995 as the base year. On May 16, 2002, the Danish parliament voted for the Danish ratification of the Kyoto Protocol. Denmark (including Greenland and excluding the Faroe Islands) is, thus, under a legal commitment to meet the requirements of the Kyoto Protocol, when it came into force on the 16th of February 2005. Hence, Denmark (including Greenland) was committed to reduce greenhouse gases with 8 %. The European Union was under the first commitment period of the Kyoto Protocol committed to reduce emissions of greenhouse gases by 8 %. However, within the EU member states have made a political agreement – the Burden Sharing Agreement – on the contributions to be made by each member state to the overall EU reduction level of 8 %.

Under the Burden Sharing Agreement, Denmark (excluding Greenland and the Faroe Islands) had to reduce emissions by an average of 21 % in the period 2008-2012 compared with the base year emission level.

For the second commitment period, the EU has a target of 20 % reduction compared to the base year. The reduction commitment within the EU distinguishes between the emissions covered by the EU Emission Trading System (ETS) and the non-ETS emissions. For the ETS there is a reduction of 24 % in allowances. For the non-ETS emissions, each Member State has a separate target set out in the Effort Sharing Decision, (ESD) (Decision No 406/2009/EC). In the ESD, Denmark has a reduction commitment of 20 % in 2020 compared to the emission level in 2005.

In accordance with the Kyoto Protocol, Denmark's base year emissions include the emissions of CO₂, CH₄ and N₂O in 1990 and Denmark has chosen 1995 as the base year for the emissions of HFCs, PFCs and SF₆ and NF₃.

1.1.4 The role of the European Union

The European Union (EU) is a party to the UNFCCC and the Kyoto Protocol. Therefore, the EU has to submit similar datasets and reports for the collective 28 EU Member States². For the commitment in the second commitment

² The status of the United Kingdom of Great Britain and Northern Ireland for the future greenhouse reporting is unknown at the time of writing.

period, the EU has entered into an agreement with Iceland on joint fulfilment.

The EU imposes some additional guidelines and obligations to the Member States through Regulation No. 525/2013/EU concerning a mechanism for monitoring and reporting greenhouse gas emissions and for implementing the Kyoto Protocol (EU monitoring mechanism). The Implementing Regulation detailing the reporting requirements was decided in 2014 (749/2014/EU). As mentioned above the ESD is the legal framework for Member States reduction commitments in the non-ETS sectors.

1.1.5 Background information on supplementary information required under KP article 7.1

For the LULUCF activities under Article 3, paragraphs 3 and 4, of the Kyoto Protocol Denmark has chosen annual accounting. Article 3.3 covers direct, human induced afforestation (A), reforestation (R) and deforestation (D) activities, and accounting of these activities is mandatory. Under Article 3.4 Denmark elected the activities Forest Management (FM), Cropland Management (CM) and Grazing Land Management (GM) for accounting in the first Commitment Period (CP) and hence these activities are mandatory for the second commitment period. No further activities were elected by Denmark for the second commitment period.

1.2 A description of the institutional arrangement for inventory preparation

On behalf of the Ministry of Environment and Food and the Ministry of Climate, Energy and Utilities, the Danish Centre for Environment and Energy (DCE) is responsible for the calculation and reporting of the Danish national emission inventory to the EU, the UNFCCC (United Nations Framework Convention on Climate Change) and UNECE CLRTAP (Convention on Long-Range Transboundary Air Pollution). Hence, DCE prepares and publishes the annual submission for Denmark to the EU and UNFCCC of the National Inventory Report and the GHG inventories in the Common Reporting Format, in accordance with the UNFCCC guidelines. Furthermore, DCE is responsible for reporting the national inventory for the Kingdom of Denmark to the UNFCCC. DCE is also the body (Single National Entity) designated with overall responsibility for the national inventory under the Kyoto Protocol.

The work concerning the annual greenhouse gas emission inventory is carried out in cooperation with Danish ministries, research institutes, organisations and companies. The Government of Greenland is responsible for finalising and transferring the inventory for Greenland to DCE. The environmental authority in the Faroe Islands (Umhvørvisstovan) is responsible for finalising and transferring the inventory for the Faroe Islands to DCE.

There are now data agreements in place with both Greenland and the Faroe Islands ensuring the data delivery. These agreements contain deadlines for when DCE is to receive the data and documentation.

DCE has been and is engaged in the work in connection with meetings of the Conference of the Parties (COP) to the UNFCCC, the Conference of the Parties serving as the Meeting of the Parties (CMP) to the Kyoto protocol and the Conference of the Parties serving as the Meeting of the Parties (CMA) to

the Paris Agreement and the subsidiary bodies, where the reporting rules are negotiated and settled. Furthermore, DCE participates in the EU Monitoring Mechanism, Working Group 1 (WG1), where the guidelines, methodologies etc. on inventories to be prepared by the EU Member States are regulated.

The main experts responsible for the sectoral inventories and the corresponding chapters and annexes in this report are:

Project leader		Ole-Kenneth Nielsen (okn@envs.au.dk)
Sector	Sub-sector	Responsible expert(s)
Energy	Stationary combustion:	Malene Nielsen
	Transport and other mobile sources	Morten Winther
	Fugitive emissions:	Marlene Plejdrup
Industrial processes and product use		Katja Hjelgaard
Agriculture		Mette Hjorth Mikkelsen
		Rikke Albrektsen
LULUCF	Forestry	Vivian Kvist Johannsen
	Harvested wood products	Vivian Kvist Johannsen
LULUCF	Cropland, grassland, wetlands, settlements	Steen Gyldenkærne
Waste		Ole-Kenneth Nielsen
Greenland		Lene Baunbæk
Faroe Islands		Maria Gunnleivsdóttir Hansen

The work concerning the annual greenhouse emission inventory is carried out in cooperation with other Danish ministries, research institutes, organisations and companies:

Danish Energy Agency, the Ministry of Climate, Energy and Utilities: Annual energy statistics in a format suitable for the emission inventory work and fuel-use data for the large combustion plants. Company reports submitted under EU ETS.

Danish Environmental Protection Agency, the Ministry of the Environment and Food: Database on waste and emissions of F-gases.

Danish Nature Agency, the Ministry of the Environment and Food: Database on Danish wastewater quality parameters.

Statistics Denmark, the Ministry of Social Affairs and the Interior: Statistical yearbook, sales statistics for manufacturing industries and agricultural statistics.

Danish Centre for Food and Agriculture (DCA), Aarhus University: Data on use of mineral fertiliser, feeding stuff consumption and nitrogen turnover in animals.

Department of Transport, Technical University of Denmark: Number of vehicles grouped in categories corresponding to the EU classification, mileage (urban, rural, highway), trip speed (urban, rural, highway).

Department of Geosciences and Natural Resource Management, University of Copenhagen: Background data for Forestry and CO₂ uptake by forest. Re-

sponsible for preparing estimates of emissions/removals for reporting under KP article 3.3 and for reporting FM under article 3.4.

Civil Aviation Agency of Denmark, the Ministry of Transport and Housing: City-pair flight data (aircraft type and origin and destination airports) for all flights leaving major Danish airports.

Danish Railways, the Ministry of Transport and Housing: Fuel-related emission factors for diesel locomotives.

Danish companies: Audited green accounts and direct information gathered from producers and agency enterprises.

Formerly, the provision of data was strictly on a voluntary basis, but more formal agreements are now prepared. This is the case for e.g. the Danish Energy Agency, where the data agreement specifies the data needed and the deadlines for when DCE is to receive the data. Agreements are also in place with DCA, Statistics Denmark and the Ministry of Transport and Housing.

No written agreements are done with companies, but most of the information used in the inventory is based on other legal requirements under environmental law.

Additionally, DCE receives data from Greenland and the Faroe Islands in order to report for the Kingdom of Denmark. In both cases based on written data agreements.

The Ministry of Industry, Energy and Research, Government of Greenland: Complete CRF tables for Greenland and documentation for the inventory process.

The Faroe Islands Environmental Authority: Complete CRF tables for the Faroe Islands and documentation for the inventory process.

The complete emission inventories for the three different submissions (EU, Kyoto Protocol and UNFCCC) by Denmark are compiled by DCE and along with the documentation report (NIR) sent for official approval. In recent years, the responsibility for official approval has changed. Previously it was the Danish Environmental Protection Agency (Ministry of the Environment); now it is the Danish Energy Agency (Ministry of Climate, Energy and Building). This means that the emission inventory is finalised no later than March 15, whereupon the official approval is done prior to the reporting deadlines under the UNFCCC and the Kyoto Protocol.

1.3 Brief description of the process of inventory preparation. Data collection and processing, data storage and archiving

The background data (activity data and emission factors) for estimation of the Danish emission inventories is collected and stored in central databases located at the Department of Environmental Science (ENVS), Aarhus University. The databases are in Access format and handled with software developed by the European Environmental Agency and developed originally by the former National Environmental Research Institute (NERI), but is now maintained and further developed by ENVS. As input to the databases, various sub-models are used to estimate and aggregate the background data in

order to fit the format and level in the central databases. The methodologies and data sources used for the different sectors are described in Chapter 1.4 and Chapters 3 to 9. As part of the QA/QC plan (Chapter 1.6), the data structure for data processing supports the pathway from collection of raw data to data compilation, modelling and final reporting.

For each submission, databases and additional tools and sub-models are frozen together with the resulting CRF-reporting format. This material is placed on central institutional servers, which are subject to routine back-up services. Material, which has been backed up, is archived safely. A further documentation and archiving system is the official archive for DCE. In this archiving system, correspondence, both incoming and outgoing, is registered, which in this case involves the registration of submissions and communication on inventories with the UNFCCC Secretariat, the European Commission, review teams, etc.

Figure 1.1 shows a schematic overview of the process of inventory preparation. The figure illustrates the process of inventory preparation from the first step of collecting external data to the last step, where the reporting schemes are generated for the UNFCCC and EU (in the CRF format (Common Reporting Format)) and to the United Nations Economic Commission for Europe/Cooperative Programme for Monitoring and Evaluation of the Long-range Transmission of Air Pollutants in Europe (UNECE/EMEP) (in the NFR format (Nomenclature For Reporting)). For data handling, the software tool is CollectER (Pulles et al., 1999) and for reporting the software tool is the CRF reporter tool developed by the UNFCCC Secretariat together with additional tools originally developed by NERI, but now maintained and further developed by ENVS. Data files and programme files used in the inventory preparation process are listed in Table 1.1.

Table 1.1 List of current data structure; data files and programme files in use.

QA/QC Level	Name	Application type	Path	Type	Input sources
4 store	CFR Submissions (UNFCCC and EU)	External report	U:\ST_ENVS-Luft-Emi\Inventory\AllYears\8_AllSectors\Level_4a_Storage\	MS Excel, xml	CRF Reporter
4 store	NFR Report	External report	U:\ST_ENVS-Luft-Emi\Inventory\AllYears\8_AllSectors\Level_4a_Storage\	xls	NRF Report N8 Process
3 process	CRF Reporter	Management tool	Working path: local machine Archive path: U:\ST_ENVS-Luft-Emi\Inventory\AllYears\8_AllSectors\Level_3b_Processes	(exe + mdb)	National Compiler and Importer2CRF(xml) and IDAtoCRF(xml)
3 process	NRF Report N8 Process	Help tool	U:\ST_ENVS-Luft-Emi\Inventory\AllYears\8_AllSectors\Level_3b_Processes\NFR	Excel	NERIRep and Report Template (xls)
3 process	Importer2CRF	Help tool	U:\ST_ENVS-Luft-Emi\Inventory\AllYears\8_AllSectors\Level_3b_Processes	MS Access	CRF Reporter, CollectEr2CRF, and excel files
3 process	CollectER2CRF	Help tool	U:\ST_ENVS-Luft-Emi\Inventory\AllYears\8_AllSectors\Level_3b_Processes	MS Access	NERIRep
3 process	IDA2CRF	Help tool	U:\ST_ENVS-Luft-Emi\Inventory\AllYears\8_AllSectors\Level_3b_Processes	MS Access	IDA_backend
2 process 3 store	NERIRep	Help tool	Working path: I:\ROSPROJ\LUFT_EMIDMURep	MS Access	CollectER databases; dk1972.mdb.dkxxxx.mdb and IDA_backend
2 process	CollectER	Management tool	Working path: local machine Archive path: U:\ST_ENVS-Luft-Emi\Inventory\AllYears\8_AllSectors\Level_2b_Processes	(exe + mdb)	Sector Expert
2 store	dk1980.mdb.dkxxxx.mdb	Datastore	U:\ST_ENVS-Luft-Emi\Inventory\AllYears\8_AllSectors\Level_2a_Storage	MS Access	CollectER
1 process	IDA	Management	U:\ST_ENVS-Luft-Emi\Agriculture\InventoryAgricultureData	MS Access	Sector Expert
1 store	IDA_Backend	Datastore	U:\ST_ENVS-Luft-Emi\Agriculture\InventoryAgricultureData	MS Access	IDA

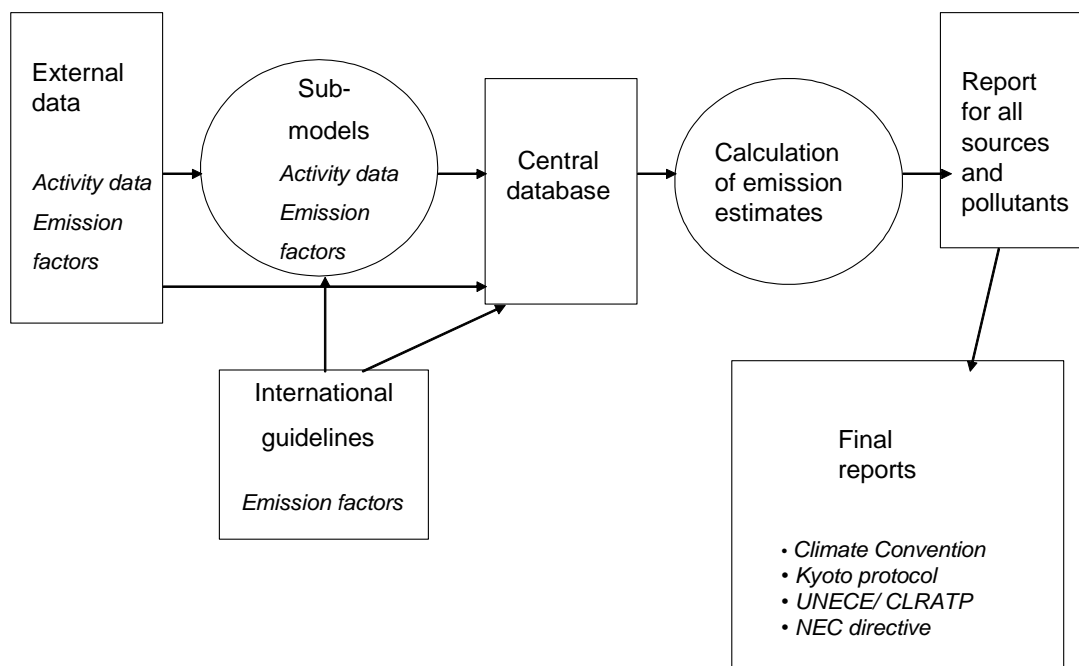

Figure 1.1 Schematic diagram of the process of inventory preparation.

Denmark has different geographical definitions for different submissions. Under the European Union, only mainland Denmark is included. For the reporting under the Kyoto Protocol, the submission includes Denmark and Greenland under the first commitment period and only Denmark for the reporting under the second commitment period. The reporting under the UNFCCC includes Denmark, Greenland and the Faroe Islands.

Due to the different geographical scopes of the Danish inventory submissions, it is necessary to operate three different versions of the CRF Reporter.

For the preparation of the Danish submission under the Kyoto Protocol, the full Danish CRF is aggregated with the Greenlandic CRF and for the UNFCCC reporting this is also aggregated with the CRF of the Faroe Islands. Under the Kyoto Protocol, Denmark now reports two submissions: one following the definition in the first commitment period and one following the definition for the second commitment period.

The process of aggregation requires additional software tools and two additional installations of CRF Reporter. The process of aggregating the KP inventory is described in Chapter 17.

1.4 Brief general description of methodologies and data sources used

Denmark's air emission inventories are based on the 2006 IPCC Guidelines and the CORINAIR methodology. CORINAIR (COOrdination of INformation on AIR emissions) is a European air emission inventory programme for national sector-wise emission estimations, harmonised with the IPCC guidelines. To ensure estimates are as timely, consistent, transparent, accurate and comparable as possible, the inventory programme has developed calculation methodologies for most subsectors and software for storage and further data processing (EMEP-/CORINAIR, 2007).

A thorough description of the CORINAIR inventory programme used for Danish emission estimations is given in Illerup et al. (2000). The CORINAIR calculation principle is to calculate the emissions as activities multiplied by emission factors. Activities are numbers referring to a specific process generating emissions, while an emission factor is the mass of emissions per unit activity. Information on activities to carry out the CORINAIR inventory is largely based on official statistics. The most consistent emission factors have been used either as national values or as default factors proposed by international guidelines.

A list of all subsectors at the most detailed level is given in Illerup et al. (2000) together with a translation between CORINAIR and IPCC codes for sector classifications.

1.4.1 Stationary Combustion Plants

Stationary combustion plants are part of the CRF emission sources *1A1 Energy Industries*, *1A2 Manufacturing Industries* and *1A4 Other sectors*.

The Danish emission inventory for stationary combustion plants is based on the CORINAIR system described in Illerup et al. (2000). The emission inventory for stationary combustion is based on activity rates from the Danish energy statistics. General emission factors for various fuels, plants and sectors

have been determined. Some large plants, such as power plants, are registered individually as large point sources and plant-specific emission data are used.

The fuel consumption rates are based on the official Danish energy statistics prepared by the Danish Energy Agency (DEA). DCE aggregates fuel consumption rates to SNAP categories. The fuel consumption of the NFR category 1A4 Manufacturing industries and construction is disaggregated to subsectors according to the DEA data prepared and reported to Eurostat.

For each of the fuel and SNAP categories (sector and e.g. type of plant), a set of general emission factors has been determined. Some emission factors refer to the EMEP/EEA guidebook and some are country specific and refer to Danish legislation, Danish research reports or calculations based on emission data from a considerable number of plants.

Some of the large plants, such as e.g. power plants and municipal waste incineration plants are registered individually as large point sources and emission data from the actual plants are used. This enables use of plant specific emission factors that refer to emission measurements stated in annual environmental reports, etc. At present, the emission factors for CH₄ and N₂O are, however, not plant-specific, whereas emission factors for SO₂ and NO_x often are. For CO₂ it was possible to use data reported under the EU-ETS in the emission inventory from 2006. Therefore, it was possible to derive some plant specific CO₂ emission factors for coal and oil fired power plants.

The CO₂ from incineration of the plastic part of municipal waste is included in the Danish inventory.

Please refer to Chapter 3.2 and Annex 3A for further information on the emission inventory for stationary combustion plants.

1.4.2 Transport

The emissions from transport, referring to SNAP category 07 (road transport) and the sub-categories in 08 (other mobile sources), are made up in the IPCC categories: 1A2f (Industry-other), 1A3a (Civil aviation), 1A3b (road transport), 1A3c (Railways), 1A3d (Navigation), 1A4a (Commercial and Institutional), 1A4b (Residential), 1A4c (Agriculture/forestry/fisheries) and 1A5 (Other).

An internal DCE model with a structure similar to the European COPERT IV emission model (EEA, 2019) is used to calculate the Danish annual emissions for road traffic. The emissions are calculated for operationally hot engines, during cold start and fuel evaporation. The model also includes the emission effect of catalyst wear. Input data for vehicle stock and mileage is obtained from DTU Transport and Statistics Denmark, and is grouped according to average fuel consumption and emission behaviour. For each group, the emissions are estimated by combining vehicle type and annual mileage figures with hot emission factors, cold:hot ratios and evaporation factors (Tier 2 approach).

For air traffic, from 2001 onwards estimates are made on a city-pair level, using flight data provided by the Danish Civil Aviation Agency (CAA-DK) for flights between Danish airports and flights between Denmark and Greenland/Faroe Islands), and LTO and distance-related emission factors from the

CORINAIR guidelines (Tier 2 approach). For previous years, the background data consists of LTO/aircraft type statistics from Copenhagen Airport and total LTO numbers from CAA-DK. With appropriate assumptions, consistent time series of emissions are produced back to 1990, and include the findings from a Danish city-pair emission inventory in 1998.

Off-road working machines and equipment are grouped in the following sectors: inland waterways (pleasure craft), agriculture, forestry, industry, and household and gardening. The sources for stock and operational data are various branch organisations and key experts. In general, the emissions are calculated by combining information on the number of different machine types and their respective load factors, engine sizes, annual working hours and emission factors (Tier 2 approach).

The inventory for navigation consists of regional ferries, local ferries and other national sea transport (sea transport between Danish ports and between Denmark and Greenland/Faroe Islands). For regional ferries, the fuel consumption and emissions are calculated as a product of number of round trips per ferry route (Statistics Denmark), sailing time per round trip, share of round trips per ferry, engine size, engine load factor and fuel consumption/emission factor. The estimates take into account the changes in emission factors and ferry specific data during the inventory period.

For the remaining navigation categories, the emissions are calculated simply as a product of total fuel consumption and average emission factors. For each inventory year, this emission factor average comprises the emission factors for all present engine production years, according to engine life times.

Please refer to Chapter 3.3 and Annex 3B for further information on emissions from transport.

1.4.3 Fugitive emissions from fuels

Fugitive emissions from oil (1.B.2.a)

Fugitive emissions from oil are estimated according to the methodology described in the Emission Inventory Guidebook (EEA, 2019). The sources include offshore extraction of oil and gas, onshore oil tanks, onshore and offshore loading of ships, and gasoline distribution. Activity data is given in the Danish Energy Statistics by the Danish Energy Agency. The emission factors are based on the figures given in the guidebook except in the case of onshore oil tanks and gasoline distribution where national values are included.

The VOC emissions from petroleum refinery processes cover non-combustion emissions from feed stock handling/storage, petroleum products processing, and product storage/handling. SO₂ is also emitted from non-combustion processes and it includes emissions from product processing and sulphur-recovery plants. The emission calculations are based on information from the Danish refineries.

Fugitive emissions from natural gas (1.B.2.b)

Inventories of NMVOC emission from transmission and distribution of natural gas and town gas are based on annual environmental reports from the Danish gas transmission company and annual reports for the gas distribution companies. The annual gas composition is based on Energinet.dk.

Fugitive emissions from flaring (1.B.2.c)

Emissions from flaring offshore, in gas treatment and storage plants, and in refineries are included in the inventory. Emissions calculations are based on annual reports from the Danish Energy Agency and environmental reports from gas storage and treatment plants and the refineries. Calorific values are based on the reports for the EU ETS for offshore flaring, on annual gas quality data from Energinet.dk, and on additional data from the refineries. Emission factors are based on the Emission Inventory Guidebook (EEA, 2019).

Please refer to Chapter 3.5 for further information on fugitive emissions from fuels.

1.4.4 Industrial processes and product use

Energy consumption associated with industrial processes and the emissions thereof are included in the Energy sector of the inventory. This is due to the overall use of energy balance statistics for the inventory.

There is only one producer of cement in Denmark, Aalborg Portland Ltd. The activity data for the production of cement clinker is obtained from the company and the CO₂ emission is from the company report to EU-ETS. The methodology is approved by the Danish Energy Agency and the yearly emission estimate is in accordance with the methodology.

The reference for the activity data for production of lime, hydrated lime, expanded clay products and bricks, is the production statistics from the manufacturing industries, published by Statistics Denmark.

Limestone is used for the refining of sugar as well as for wet flue gas cleaning at power plants and waste incineration plants. The reference for the activity data is Statistics Denmark for sugar, Energinet.dk for gypsum from power plants combined with specific information on consumption of CaCO₃ at specific power plants and National Waste Statistics for gypsum from waste incineration. The emission factors are based on stoichiometric relations between consumption of CaCO₃ and gypsum generation as well as consumption of lime for sugar refining and precipitation with CO₂. This information is supplemented with company reports to EU-ETS.

The reference for the activity data for asphalt roofing is Statistics Denmark for consumption of roofing materials, combined with technical specifications for roofing materials produced in Denmark. The emission factors are default factors.

For road paving with asphalt, the reference for the activity data is Statistics Denmark for consumption of asphalt and cutback asphalt. The emission factors are default factors for consumption of asphalt and an estimated emission factor for cutback asphalt based on the statistics on the emission of NMVOC compiled by the industrial organisations in question.

The reference for activity data for the production of glass and glass wool are obtained from the producers published in their environmental reports. Emission factors are based on stoichiometric relations between raw materials and CO₂ emissions. This information is supplemented with company reports to EU-ETS.

The production of lime and yellow bricks gives rise to CO₂ emissions. The emission factors are based on stoichiometric relations, assumption on CaCO₃ content in clay as well as a default emission factor for expanded clay products. This information is supplemented with company reports to EU-ETS.

There was one producer of nitric acid in Denmark. The data in the inventory relies on information from the producer. The producer reported emissions of NO_x and NH₃ as measured emissions and emissions of N₂O for 2003 as estimated emissions. The emission of N₂O in 2005 and forward is not occurring as the nitric acid production was closed down in the middle of 2004.

There is one producer of catalysts in Denmark. The data in the inventory relies on information published by the producer in environmental reports.

There was one steelwork in Denmark. The activity data as well as data on consumption of raw materials (coke) has been published by the producer in environmental reports. Emission factors are based on stoichiometric relations between raw materials and CO₂ emission. The electro steelwork was closed in 2005.

The inventory on F-gases (HFCs, PFCs and SF₆) is based on work carried out by the Danish Consultant Company "Provice". Their yearly report (DEPA, 2021) documents the inventory data up to the year 2019. The methodology is implemented for the whole time series 1990-2019, but full information on activities only exists since 1995.

Emissions from other product use such as fireworks, tobacco and charcoal for grilling are included in the inventory. Activity data on consumption of fireworks, tobacco and charcoal are obtained from Statistics Denmark. The emission factors used refer to international literature.

Please refer to Chapter 4 for further information on the emission inventory for industrial processes and product use.

1.4.5 Agriculture

The calculation of emissions from the agricultural sector is based on methods described in the IPCC Guidelines (IPCC, 2006). Activity data for livestock is on a one-year average basis from the agricultural statistics published by Statistics Denmark (2020). Data concerning the land use and crop yield is also from the agricultural statistics. Data concerning the feed consumption and nitrogen excretion is based on information from the Danish Centre for Food and Agriculture (Aarhus University). The CH₄ Implied Emission Factors for Enteric Fermentation and Manure Management are based on a Tier 2/CS approach for all animal categories except for poultry, which are based on a Tier 1 approach. All livestock categories in the Danish emission inventory are based on an average of certain subgroups separated by differences in animal breed, age and weight class. The emissions from enteric fermentation for fur farming are estimated to be not applicable.

Emission of N₂O is closely related to the nitrogen balance. Thus, quite a lot of the activity data is related to the Danish calculations for ammonia emission (Albrektsen et al., 2017). National standards are used to estimate the amount of ammonia emission. When estimating the N₂O emission the IPCC standard value is used for all emission sources. The emission of CO₂ from Agricultural Soils is included in the LULUCF sector.

A model-based system is applied for the calculation of the emissions in Denmark. This model (IDA - Integrated Database model for Agricultural emissions) is used to estimate emission from both greenhouse gases and ammonia. A more detailed description is published in Mikkelsen et al. (2011). The emissions from the agricultural sector are mainly related to livestock production. IDA works on a detailed level and includes around 38 livestock categories, and each category is subdivided according to housing type and manure type. The emissions are calculated from each subcategory and the emissions are aggregated in accordance with the livestock category given in the CRF.

To ensure data quality, both data used as activity data and background data used to estimate the emission factor are collected, and discussed in cooperation with specialists and researchers in different institutions. Thus, the emission inventory will be evaluated continuously according to the latest knowledge. Furthermore, time series of both emission factors and emissions in relation to the CRF categories are prepared. Any considerable variations in the time series are explained.

The uncertainties for assessment of emissions from enteric fermentation, manure management, agricultural soils and field burning of agricultural residue have been estimated based on a Tier 1 approach. The most significant uncertainties are related to the emissions of N₂O from agricultural soils.

A more detailed description of the methodology for the agricultural sector is given in Chapter 5 and Annex 3D.

1.4.6 Land Use, Land Use Change and Forestry

A complete Land Use Change matrix based on satellite imaging of the entire Danish land area, together with cadastral information has been prepared for the six major area classes. This has improved the coverage and the quality of the inventory substantially.

CO₂ emissions from cropland and grassland are based on census data from Statistics Denmark as regards size of area and crop yield combined with GIS-analysis on land use from the EU agricultural subsidiary system. This gives a very high accuracy for land use. All applicable pools are reported for Cropland and Grassland. The emission from mineral soils for cropland is estimated with a three-pooled dynamical soil carbon model (C-TOOL). C-TOOL was initialised in 1980. The model is run for each region corresponding to former counties in Denmark. Emissions from organic soils in cropland are based on new nationally developed emission factors. For grassland IPCC Tier 1b values are used. National models have been developed for wooden perennial crops in cropland based on land use statistics from Statistic Denmark. These are of minor importance. Sinks in hedgerows are calculated based on a nationally developed model. The area with hedgerows is estimated from information on hedgerows established with financial support from the Danish Government and aerial photos. Emissions from liming are calculated from annual sales data collected by the Danish Agricultural Advisory Centre, combined with the acid neutralisation capacity for each lot produced.

For wetlands, emissions are reported from peat extraction areas. Natural wetlands are not reported. A comprehensive programme for restoration of

wetlands is implemented in Denmark. Other land uses converted to wetlands is therefore reported.

For having estimates for the KP accounting other land uses converted to settlements is reported but not settlements remaining as settlements.

No estimates are made for other land remaining other land and no conversion of land to other land is occurring. For having estimates for the KP accounting estimates for living biomass are provided for land converted from other land to other land uses.

1.4.7 Waste

For 5.A Solid waste disposal, only managed waste disposal sites are of importance and registered; i.e. unmanaged and illegal disposal of waste is considered to play a negligible role in the context of this category. The CH₄ emission at the Danish SWDSs is based on a First Order Decay (FOD) model corresponding to an IPCC tier 2/3 approach (IPCC, 2006). Data on waste types and amounts deposited at solid waste disposal sites is according to the official registration collected by the Danish Environmental Protection Agency (DEPA, 2020). The model calculations are performed using landfill site characteristics and statistics on the amounts of waste fractions deposited each year. Improved documentation of the methodology, input parameter data including uncertainty analysis is described in Chapter 7.2.

Regarding 5.C Incineration and open burning of waste, all municipal, industrial, hazardous and medical waste incinerated is used for energy and heat production. This production is included in the energy statistics, hence emissions are included in the CRF under fuel combustion activities (CRF sector 1A), and more specifically waste incineration takes place in CRF sectors 1A1a, 1A2f and 1A4a. Reporting in this category covers incineration of corpses and carcasses. The activity data are obtained from the National Association of Danish Crematoria and the three facilities incinerating carcasses.

For 5.D Wastewater treatment and discharge, country-specific methodologies are used for calculating the emissions of CH₄ and N₂O at wastewater treatment plants (WWTPs). Fugitive methane releases from the municipal and private WWTPs have been divided into contributions from 1) the sewer system, primary settling tank and biological N and P removal processes, 2) from anaerobic treatment processes in closed systems with biogas extraction and combustion for energy production and 3) septic tanks. N₂O formation and releases during the treatment processes at the WWTPs and from discharged effluent wastewater are included. Documentation of the methodology, emission factors and activity data are included in Chapter 7.3.

In CRF category 5.E Other emissions from accidental fires have been reported.

Please refer to Chapter 7 and Annex 3F for further information on emission inventories for waste.

1.4.8 KP-LULUCF

The national system has identified land areas associated with the activities under Article 3.4 of the Kyoto Protocol in accordance with definitions, modalities, rules and guidelines relating to land use, land-use change and for-

estry activities under the protocol. The identification has been made using satellite monitoring, use of the EU Land Parcel Information System (LPIS), detailed crop information data on field level, soil mapping and sample plots from the National Forest Inventory (NFI). All land converted from other activities into cropland and grassland is accounted for. No land can leave elected areas under art. 3.4.

The forest definition adopted in the NFI is identical to the FAO definition (TBFRA, 2000). It includes “wooded areas larger than 0.5 ha, that are able to form a forest with a height of at least 5 m and crown cover of at least 10 %”. The minimum width is 20 m. For afforestation, the carbon stock change in the period 1990 - 2011 is calculated based on the area of afforestation, the information on species composition from the Forest Census 2000 and from the NFI. In the afforestation, a steady increase in carbon stock is found. The estimates for the carbon pools in the afforestation are similar to previous estimates, with a slight increase due to the new knowledge on species composition, average carbon stock in those areas based on the NFI data and new data on the carbon stock in soils. Carbon stock change caused by deforestation is estimated based on the deforested area and the mean values of carbon stock in the total forest area. This is because no specific knowledge is available on the carbon pools of the deforested areas. For Forest Management, census and NFI data are used.

For cropland and grassland, the same methodology is used in the KP reporting as used in the Convention reporting.

Please see Chapter 10 for further details.

1.4.9 Use of EU Emission Trading Scheme data

In 2004, the first guidelines for the monitoring and reporting of greenhouse gas emissions pursuant to the EU Emission Trading Scheme (ETS) Directive (2003/87/EC) were implemented (EU Commission, 2004). The guidelines were updated in 2007, 2012 and 2018 and are available from the EU Commission website (EU Commission, 2018).

The Danish emission inventory only includes data from plants using higher tier methods as defined in the EU decision establishing guidelines for monitoring and reporting (EU Commission, 2018). In the Guidelines, the specific methods for determining carbon contents, oxidation factor and calorific value are specified.

In the Danish inventory plant or activity based CO₂ emission factors have been derived for power plants combusting coal and oil, refinery gas and flare gas in refineries, fuel gas and flare gas at off-shore installations, cement production, production of brick and tiles and lime production. For all these sources, the EU ETS reports are only used in the Danish inventory for plants using high tier methods. The EU ETS data have been applied for the years 2006 onwards.

The EU ETS reporting guidelines emphasizes the need for a high quality reporting through ensuring completeness, consistency, accuracy, transparency and faithfulness. The quality criteria as defined under the EU ETS reporting guidelines are in complete agreement with the principles in the IPCC good practice guidance. For all activities covered by the EU ETS installations are divided into three categories (A, B and C) depending on the annual CO₂

emission. A category A installation has an annual emission of less than 50 kt CO₂, a category B installation has an annual emission of between 50 and 500 kt CO₂ and a category C installation has an annual emission of more than 500 kt CO₂. For each activity Table 1 of the EU ETS guidelines (EU Commission, 2018) specifies the minimum tier level for the different calculation parameters. An example for combustion installations is shown in Table 1.2. The full list for all activities is available in the EU ETS guidelines (EU Commission, 2018).

Table 1.2 Example of minimum requirements in EU ETS guidelines (EU Commission, 2018).

Activity	Activity data						Emission factor			Oxidation factor		
	Fuel flow			Net calorific value			A	B	C	A	B	C
	A	B	C	A	B	C						
Commercial standard fuels	2	2	2	2a/2b	2a/2b	2a/2b	2a/2b	2a/2b	2a/2b	1	1	1
Other gaseous and liquid fuels	2	3	4	2a/2b	2a/2b	3	2a/2b	2a/2b	3	1	1	1
Solid fuels	1	2	3	2a/2b	3	3	2a/2b	3	3	1	1	1

The determination of the variables needed for the emission calculation has to be done in accordance with international standards. It is not possible to list all the relevant standards here, but the principles are described in Article 42 of the EU ETS guidelines. There are also demands concerning sampling methods and frequency of analysis.

As an example the tier 3 regarding fuel flow for fuel combustion, corresponds to a determination of the fuel consumption with a maximum uncertainty of 2.5 % taking into account possible effects of stock change. Tier 4 has a maximum uncertainty of 1.5 %. These uncertainties are very low and are in line with what could be expected from a well-functioning energy statistics system. More information regarding the use of EU ETS data in the specific subsectors of the inventory is included in Chapter 3.2.5 (CHP plants), Chapter 3.5.2 (Refineries and off-shore installations) and Chapter 4.2.2 (Cement production and other mineral products).

The operators shall establish, document, implement and maintain effective data acquisition and handling activities. This means assigning responsibilities for the quality process, as well as quality assurance, reviews and validation of data. Furthermore, an independent verification ensuring that emissions have been monitored in accordance with the EU ETS guidelines and that reliable and correct emission data are reported. There are also demands that records and documentation of the control activities must be stored for at least 10 years. The demands for the QA/QC system in the EU ETS guidelines are fully comparable to the requirements in the IPCC good practice guidance. Even so, DCE also performs QC checks of the data received as part of company reporting under EU ETS. This includes comparing the reported parameters with previous years, identifying outliers etc. In case DCE detects what is considered to be outliers, DCE contacts the Danish Energy Agency, which is the regulating authority for the EU ETS system in Denmark.

1.5 Brief description of key categories

The key category analysis described in this section covers only Denmark. The aggregation used for the analysis is not directly suited for emissions from Greenland. If Greenlandic emissions were included in the analysis, they would not affect the overall results of the key category analysis. For a

key category analysis covering Greenland refer to Chapter 16 and for Denmark and Greenland refer to Chapter 17.

All KCA have been carried out in accordance with IPCC Guidelines (IPCC, 2006).

The KCA for Denmark includes a total of 12 different analyses:

- Base year, reporting year and trend
- Including and excluding LULUCF
- Approach 1 and approach 2

The KCA is based on 224 emission source categories including 35 LULUCF source categories.

The 12 different KCA for Denmark point out 22-48 key source categories each and a total of 74 different key source categories. The number of key categories in each of the main sectors is: energy 35, IPPU 4, agriculture 14, LULUCF 16 and waste 5.

Approach 1 point out mainly the large emission sources as key categories and thus CO₂ emission from stationary and mobile combustion are important key categories. Approach 2 point out some of the sources with larger uncertainty rates.

Table 1.3 shows the 74 source categories that are key categories in at least one of the six key category analysis including LULUCF. The table includes ranking in the analysis. A similar table for the KCAs excluding LULUCF is included in Annex 1.

The categorisation and detailed results of each of the KCAs are included in Annex 1.

Table 1.3 Key categories for KCAs including LULUCF. The numbers show the ranking in each of the KCAs.

IPCC Source Categories (LULUCF included)		GHG	Key categories with number according to ranking in analysis					
			Identification criteria					
			Level Approach 1 1990	Level Approach 1 2020	Trend Approach 1 1990-2020	Level Approach 2 1990	Level Approach 2 2020	Trend Approach 2 1990-2020
Energy	1A Stationary combustion, Coal, ETS data, CO ₂	CO ₂		4	3			
Energy	1A Stationary combustion, Coal, no ETS data, CO ₂	CO ₂	1	41	1	18		10
Energy	1A Stationary combustion, Fossil waste, ETS data, CO ₂	CO ₂		8	7			38
Energy	1A Stationary combustion, Fossil waste, no ETS data, CO ₂	CO ₂	24	25	30			
Energy	1A Stationary combustion, Petroleum coke, ETS data, CO ₂	CO ₂		18	12			
Energy	1A Stationary combustion, Petroleum coke, no ETS data, CO ₂	CO ₂	30		29			
Energy	1A Stationary combustion, Residual oil, ETS data, CO ₂	CO ₂		32	27			
Energy	1A Stationary combustion, Residual oil, no ETS data, CO ₂	CO ₂	7		6			
Energy	1A Stationary combustion, Gas oil, CO ₂	CO ₂	3	20	4	27		28
Energy	1A Stationary combustion, Kerosene, CO ₂	CO ₂	32		28			
Energy	1A Stationary combustion, LPG, CO ₂	CO ₂		39				
Energy	1A1b Stationary combustion, Petroleum refining, Refinery gas, CO ₂	CO ₂	19	14	19			
Energy	1A Stationary combustion, Natural gas, onshore, CO ₂	CO ₂	6	2	5			
Energy	1A1c_ii Stationary combustion, Oil and gas extraction, Off shore gas turbines, Natural gas, CO ₂	CO ₂	27	15	16			
Energy	1A1 Stationary Combustion, Solid fuels, N ₂ O	N ₂ O				23		19
Energy	1A1 Stationary Combustion, Waste, N ₂ O	N ₂ O						40
Energy	1A1 Stationary Combustion, Biomass, N ₂ O	N ₂ O					21	14
Energy	1A2 Stationary Combustion, Solid fuels, N ₂ O	N ₂ O					32	30
Energy	1A2 Stationary Combustion, Liquid fuels, N ₂ O	N ₂ O				21		21
Energy	1A4 Stationary Combustion, Liquid fuels, N ₂ O	N ₂ O						36
Energy	1A4b_i Stationary Combustion, Residential wood combustion, N ₂ O	N ₂ O					20	16
Energy	1.A.2.g Industry (mobile)	CO ₂	28	22	26	24	16	22
Energy	1.A.3.a Civil aviation	CO ₂	37					
Energy	1.A.3.b Road Transport	CO ₂	2	1	2	17	10	7
Energy	1.A.3.c Railways	CO ₂	35	34				
Energy	1.A.3.d Navigation (large vessels)	CO ₂	22	24				
Energy	1.A.4.a Commercial/Institutional (mobile)	CO ₂		33	37			48
Energy	1.A.4.c ii Agriculture (mobile)	CO ₂	17	17	21	25	18	25
Energy	1.A.4.c iii Fisheries	CO ₂	23	30	40			
Energy	1.A.5.b Other (small boats)	CO ₂		40				
Energy	1.A.2.g Industry (mobile)	N ₂ O						42
Energy	1.A.3.b Road Transport	N ₂ O		45				
Energy	1.A.4.c ii Agriculture (mobile)	N ₂ O					26	33
Energy	1.B.2.c.2.iii Flaring, combined	CO ₂	33					
Energy	1.B.2.c.2.iii Flaring, combined	N ₂ O				16	17	24
IPPU	2A1 Cement production	CO ₂	16	9	11			
IPPU	2B2 Nitric acid production	N ₂ O	13		15	22		17
IPPU	2F1 Refrigeration and air conditioning	HFCs		27	22		22	15
IPPU	2F2 Foam blowing agents	HFCs	38		33			31
Agriculture	3A Enteric Fermentation	CH ₄	4	3	8	11	9	9
Agriculture	3B Manure Management	CH ₄	10	6	9	19	14	11
Agriculture	3B Manure Management	N ₂ O	20	21	38	12	12	20
Agriculture	3B5 Atmospheric deposition	N ₂ O		44		26	25	

IPCC Source Categories (LULUCF included)	GHG	Key categories with number according to ranking in analysis Identification criteria					
		Level Approach 1	Level Approach 1	Trend Approach 1	Level Approach 2	Level Approach 2	Trend Approach 2
		1990	2020	1990-2020	1990	2020	1990-2020
Agriculture 3Da1 Inorganic N fertilizer	N ₂ O	9	11	39	1	1	8
Agriculture 3Da2a Animal manure applied to soils	N ₂ O	14	12	18	2	2	2
Agriculture 3Da2c Other organic fertilizer applied to soils	N ₂ O					34	29
Agriculture 3Da3 Urine and dung deposited by grazing animals	N ₂ O	34	37		10	13	
Agriculture 3Da4 Crop Residues	N ₂ O	21	13	17	4	3	1
Agriculture 3Da5 Mineralization	N ₂ O	39			14	19	13
Agriculture 3Da6 Cultivation of organic soils	N ₂ O	18	19	31	3	4	4
Agriculture 3Db1 Atmospheric deposition	N ₂ O	31	36		6	8	12
Agriculture 3Db2 Leaching	N ₂ O	26	26		7	6	37
Agriculture 3G Liming	CO ₂	25	31		15	15	26
LULUCF 4.A.1 Forest land remaining forest land, Living biomass	CO ₂	36	28				
LULUCF 4.A.1 Forest land remaining forest land, Dead organic matter	CO ₂		16	13			45
LULUCF 4.A.1 Forest land remaining forest land, Organic soils	CO ₂		46				
LULUCF 4.A.2 Land converted to forest land	CO ₂	12	10	23	28	23	46
LULUCF 4.B.1 Cropland remaining cropland, Living biomass	CO ₂		38	36			
LULUCF 4.B.1 Cropland remaining cropland, Mineral soils	CO ₂	15		14	13	31	3
LULUCF 4.B.1 Cropland remaining cropland, Organic soils	CO ₂	5	5	25	5	5	18
LULUCF 4.B.2 Forest land converted to cropland	CO ₂		47	34			34
LULUCF 4.B.2 Other land uses converted to cropland	CO ₂			41			41
LULUCF 4.C.1 Grassland remaining grassland, Living biomass	CO ₂		43	32			
LULUCF 4.C.1 Grassland remaining grassland, Organic soils	CO ₂	8	7	10	9	7	6
LULUCF 4.D.1.1 Peat extraction remaining peat extraction	CO ₂						47
LULUCF 4.E.2 Other land uses converted to settlements	CO ₂	29	35		20	24	39
LULUCF 4.G Harvested wood products	CO ₂		48	35		28	23
LULUCF 4(II) Cropland on organic soils	CH ₄					30	
LULUCF 4(II) Grassland on organic soils	CH ₄					27	43
Waste 5.A Solid waste disposal	CH ₄	11	23	20	8	11	5
Waste 5.B.1 Composting	CH ₄					29	27
Waste 5.B.2. Anaerobic digestion at biogas facilities	CH ₄		29	24			35
Waste 5.B.1 Composting	N ₂ O						32
Waste 5.D.1 Domestic wastewater	N ₂ O		42			33	44

1.5.1 KP-LULUCF

See Chapter 10 for discussion on the key category analysis of KP-LULUCF.

1.6 Information on QA/QC plan including verification and treatment of confidential issues where relevant

1.6.1 Introduction

This section outlines the Quality Control (QC) and Quality Assurance (QA) plan for greenhouse gas emission inventories performed by DCE (Sørensen et al., 2005; Nielsen et al., 2013; Nielsen et al., 2020). The plan is in accordance with the guidelines provided by the IPCC (IPCC, 2006). The ISO 9000 standards are also used as important input for the plan.

The QA/QC plan also covers Greenland. DCE receives the data corresponding to data processing level 3 and data storage level 4 and the data undergoes the same QA/QC procedure as the Danish data, some further QC checks are described in Chapter 17. The QA/QC specific to the Greenlandic emission inventory is described in Chapter 16.

1.6.2 Concepts of quality work

The quality planning is based on the following definitions as outlined by the ISO 9000 standards as well as the IPCC Guidance (IPCC, 2006):

- Quality management (*QM*) Coordinates activity to direct and control with regard to quality.
- Quality Planning (*QP*) Defines quality objectives including specification of necessary operational processes and resources to fulfil the quality objectives.
- Quality Control (*QC*) Fulfils quality requirements.
- Quality Assurance (*QA*) Provides confidence that quality requirements will be fulfilled.
- Quality Improvement (*QI*) Increases the ability to fulfil quality requirements.

The activities are considered inter-related in this report as shown in Figure 1.2.

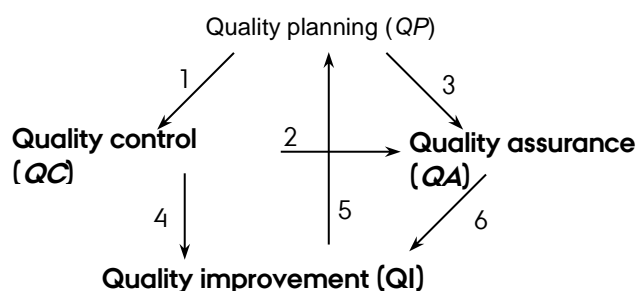

Figure 1.2 Interrelation between the activities with regard to quality. The arrows are explained in the text below this figure.

- 1: The *QP* sets up the objectives and, from these, measurable properties valid for the *QC*.
- 2: The *QC* investigates the measurable properties that are communicated to *QA* for assessment in order to ensure sufficient quality.
- 3: The *QP* identifies and defines measurable indicators for the fulfilment of the quality objectives. This yields the basis for the *QA* and has to be supported by the input coming from the *QC*.
- 4: The result from *QC* highlights the degree of fulfilment for every quality objective. It is thus a good basis for suggestions for improvements to the inventory to meet the quality objectives.
- 5: Suggested improvements in the quality may induce changes in the quality objectives and their measurability.
- 6: The evaluation carried out by external authorities is important input when improvements in quality are being considered.

1.6.3 Definition of quality

A solid definition of quality is essential. Without such a solid definition, the fulfilment of the objectives will never be clear and the process of quality control and assurance can easily turn out to be a fuzzy and unpleasant experience for the people involved. On the contrary, in case of a solid definition and thus a clear goal, it will be possible to make a valid statement of “good quality” and thus form constructive conditions and motivate the inventory work positively. A clear definition of quality has not been given in the UN-

FCCCC guidelines. In the Good Practice Guidance, Chapter 8.2, however, it is mentioned that:

“Quality control requirements, improved accuracy and reduced uncertainty need to be balanced against requirements for timeliness and cost effectiveness.” The statement of balancing requirements and costs is not a solid basis for QC as long as this balancing is not well defined.

The resulting standard of the inventory is defined as being composed of accuracy and regulatory usefulness. The goal is to maximise the standard of the inventory and the following statement defines the quality objective:

The quality objective is only inadequately fulfilled if it is possible to make an inventory of a higher standard without exceeding the frame of resources.

1.6.4 Definition of Critical Control Points (CCP)

A Critical Control Point (CCP) is defined in this submission as an element or an action, which needs to be taken into account in order to fulfil the quality objectives. Every CCP has to be necessary for the objectives and the CCP list needs to be extended if other factors, not defined by the CCP list, are needed in order to reach at least one of the quality objectives.

The objectives for the QM, as formulated by IPCC (2006), are to improve elements of transparency, consistency, comparability, completeness and confidence.

The objectives for the QM are used as CCPs, including the elements mentioned above. The following explanation is given by UNFCCC guidelines (UNFCCC, 2013) for each CCP:

Transparency means that the data sources, assumptions and methodologies used for an inventory should be clearly explained, in order to facilitate the replication and assessment of the inventory by users of the reported information. The transparency of inventories is fundamental to the success of the process for the communication and consideration of the information. The use of the common reporting format (CRF) tables and the preparation of a structured national inventory report (NIR) contribute to the transparency of the information and facilitate national and international reviews.

Consistency means that an annual GHG inventory should be internally consistent for all reported years in all its elements across sectors, categories and gases. An inventory is consistent if the same methodologies are used for the base and all subsequent years and if consistent data sets are used to estimate emissions or removals from sources or sinks. Under certain circumstances referred to in paragraphs 16 to 18 below, an inventory using different methodologies for different years can be considered to be consistent if it has been recalculated in a transparent manner, in accordance with the 2006 IPCC Guidelines for National Greenhouse Gas Inventories (hereinafter referred to as the 2006 IPCC Guidelines).

Comparability means that estimates of emissions and removals reported by Annex I Parties in their inventories should be comparable among Annex I Parties. For that purpose, Annex I Parties should use the methodologies and formats agreed by the COP for making estimations and reporting their inventories. The allocation of different source/sink categories should follow

the CRF tables provided in annex II to decision 24/CP.19 at the level of the summary and sectoral tables.

Completeness means that an annual GHG inventory covers at least all sources and sinks, as well as all gases, for which methodologies are provided in the 2006 IPCC Guidelines or for which supplementary methodologies have been agreed by the COP. Completeness also means the full geographical coverage of the sources and sinks of an Annex I Party.

Accuracy means that emission and removal estimates should be accurate in the sense that they are systematically neither over nor under true emissions or removals, as far as can be judged, and that uncertainties are reduced as far as practicable. Appropriate methodologies should be used, in accordance with the 2006 IPCC Guidelines, to promote accuracy in inventories.

The robustness against unexpected disturbance of the inventory work has to be high in order to secure high quality, which is not covered by the CCPs above. The correctness of the inventory is formulated as an independent objective. This is so because the correctness of the inventory is a condition for all other objectives to be effective. A large part of the Tier 1 procedure given by the IPCC (IPCC, 2006) is actually checks for miscalculations and, thus, supports the objective of correctness. Correctness, as defined here, is not similar to accuracy, because the correctness takes into account miscalculations, while accuracy relates to minimizing the always present data-value uncertainty.

Robustness implies arrangement of inventory work as regards e.g. inventory experts and data sources in order to minimize the consequences of any unexpected disturbance due to external and internal conditions. A change in an external condition could be interruption of access to an external data source and an internal change could be a sudden reduction in qualified staff, where a skilled person suddenly leaves the inventory work.

Correctness has to be secured in order to avoid uncontrollable occurrence of uncertainty directly due to errors in the calculations.

The different CCPs are not independent and represent different degrees of generality. E.g., deviation from *comparability* may be accepted if a high degree of *transparency* is applied. Furthermore, there may even be a conflict between the different CCPs. E.g. new knowledge may suggest improvements in calculation methods for better *completeness*, but the same improvements may to some degree, violate the *consistency* and *comparability* criteria with regard to earlier years' inventories and the reporting from other nations. It is, therefore, a multi-criteria problem of optimisation to apply the set of CCPs in the aim for good quality.

1.6.5 Process-oriented QC

The strategy is based on a process-oriented principle (ISO 9000 series) and the first step is, thus, to set up a system for the process of the inventory work. The product specification for the inventory is a dataset of emission figures and the process, thereby, equates with the data flow in the preparation of the inventory.

The data flow needs to support the QC/QA in order to facilitate a cost-effective procedure. The flow of data has to take place in a transparent way

by making the transformation of data detectable. It should be easy to find the original background data for any calculation and to trace the sequence of calculations from the raw data to the final emission result. Computer programming for automated calculations and checking will enhance the accuracy and minimize the number of miscalculations and flaws in input value settings. Especially manual typing of numbers needs to be minimized. This assumes, however, that the quality of the programming has been verified to ensure the correctness of the automated calculations. Automated value control is also one of the important means to secure accuracy. Realistic uncertainty estimates are necessary for securing accuracy, but they can be difficult to produce due to the uncertainty related to the uncertainty estimates themselves. It is, therefore, important to include the uncertainty calculation procedures into the data structure as far as possible. The QC/QA needs to be supported as far as possible by the data structure; otherwise, the procedures can easily become troublesome and subject to frustration.

Both data processing and data storage form the data structure. The data processing is carried out using mathematical operations or models. The models may be complicated where they concern human activity or be simple summations of lower aggregated data. The data storage includes databases and file systems of data that are calculated either using the data processing at the lower level, using input to new processing steps or even using both output and input in the data structure. The measure for quality is basically different for processing and storage, so these need to be kept separate in a well-designed quality manual. A graphical display of the data flow is seen in Figure 1.3 and explained in the following.

The data storage takes place for the following types of data:

External Data: a single numerical value of a parameter coming from an external source. These data govern the calculation of *Emission calculation input*.

Emission calculation input: Data for input to the final emission calculation in terms of data for release source strength and activity. The data is directly applicable for use in the standardized forms for calculation. These data are calculated using external data or represent a direct use of *External Data* when they are directly applicable for *Emission Calculations*.

Emission Data: Estimated emissions based on the *emission calculation input*.

Emission Reporting: Reporting of emission data in requested formats and aggregation level.

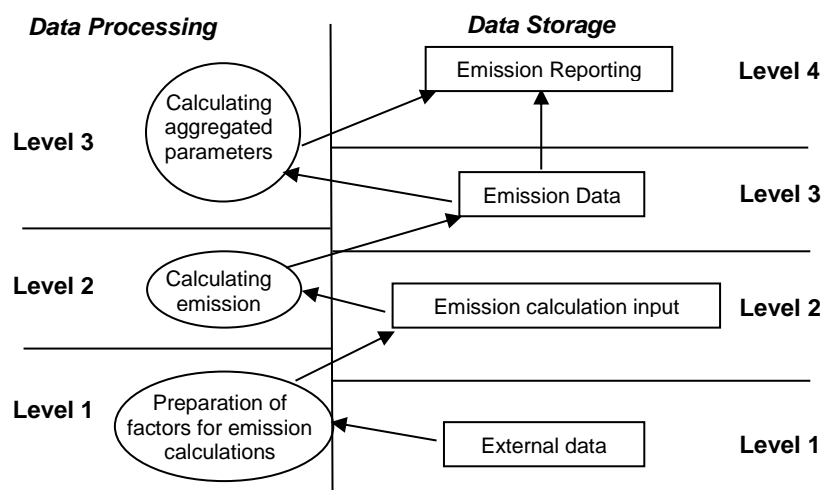

Figure 1.3 The general data structure for the emission inventory.

Key levels are defined in the data structure as:

Data storage Level 1, External data

Collection of external data for calculation of emission factors and activity data. The activity data are collected from different sectors and statistical surveys, typically reported on a yearly basis. The data consist of raw data, having an identical format to the data received and gathered from external sources. Level 1 data acts as a base-set, on which all subsequent calculations are based. If alterations in calculation procedures are made, they are based on the same dataset. When new data are introduced, they can be implemented in accordance with the QA/QC structure of the inventory.

Data storage Level 2, Data directly usable for the inventory

This level represents data that have been prepared and compiled in a form that is directly applicable for calculation of emissions. The compiled data are structured in a database for internal use as a link between more or less raw data and data that are ready for reporting. The data are compiled in a way that elucidates the different approaches in emission assessment: (1) directly on measured emission rates, especially for larger point sources, (2) based on activities and emission factors, where the value setting of these factors are stored at this level.

Data storage Level 3, Emission data

The emission calculations are reported by the most detailed figures and divided in sectors. The unit at this level is typically mass per year for the country. For sources included in the SNAP system, the SNAP level 3 is relevant. Internal reporting is performed at this level to feed the external communication of results.

Data storage Level 4, Final reports for all subcategories

The complete emission inventory is reported to UNFCCC at this level by summing up the results from every subcategory.

Data processing Level 1 Compilation of external data

Preparation of input data for the emission inventory based on the external data sources. Some external data may be used directly as input to the data processing at level 2, while other data needs to be interpreted using more or less complicated models, which takes place at this level. The interpretation of activity data is to be seen in connection with availability of emission fac-

tors and vice versa. These models are compiled and processed as an integrated part of the inventory preparation.

Data processing Level 2 Calculation of inventory figures

The emission for every subcategory is calculated, including the uncertainty for all sectors and activities. The summation of all contributions from sub-sources makes up the inventory.

Data processing Level 3 Calculation aggregated parameters

Some aggregated parameters need to be reported as part of the final reporting. This does not involve complicated calculations but important figures, e.g. implied emission factors at a higher aggregated level to be compared in time series and with other countries.

1.6.6 Definition of Point of Measurements (PM)

The CCPs have to be based on clear measurable factors - otherwise the QP will end up being just a loose declaration of intent. Thus, in the following, a series of *Points for Measuring (PM)* is identified as building blocks for a solid QC. Table 8.1 in Good Practice Guidance is a listing of such PMs. However, the listing in Table 1.2 is an extended and modified listing, in comparison to Table 8.1 in the Good Practice Guidance supporting all the CCPs. The PMs will be routinely checked in the QC reporting and, when external reviews take place, the reviewers will be asked to assess the fulfilment of the PMs using a checklist system. The list of PMs is continually evaluated and modified to offer the best possible support for the CCPs. The actual list used is seen in Table 1.4.

Table 1.4 The list of PMs as used.

Level	CCP	Id	Description		
Data Storage level 1	1. Accuracy	DS.1.1.1	General level of uncertainty for every dataset including the reasoning for the specific values	Sectoral	
		DS.1.1.2	Quantification of the uncertainty level of every single data value, including the reasoning for the specific values.	Sectoral	
	2. Comparability	DS1.2.1	Comparability of the data values with similar data from other countries, which are comparable with Denmark, and evaluation of the discrepancy.	Sectoral	
	3. Completeness	DS.1.3.1	Documentation showing that all possible national data sources are included, by setting down the reasoning behind the selection of datasets.	Sectoral	
	4. Consistency	DS.1.4.1	The origin of external data has to be preserved whenever possible without explicit arguments (referring to other PMs)	Sectoral	
	6. Robustness	DS.1.6.1	Explicit agreements between the external institution holding the data and DCE about the conditions of delivery	Sectoral	
		DS.1.6.2	At least two employees must have a detailed insight into the gathering of every external dataset.	General	
	7. Transparency	DS.1.7.1	Summary of each dataset including the reasoning behind the selection of the specific dataset	Sectoral	
		DS.1.7.2	The archiving of datasets needs to be easily accessible for any person in the emission inventory	General	
		DS.1.7.3	References for citation for any external dataset have to be available for any single number in any dataset.	Sectoral	
		DS.1.7.4	Listing of external contacts for every dataset	Sectoral	
	Data Processing level 1	1. Accuracy	DP.1.1.1	Uncertainty assessment for every data source as input to Data Storage level 2 in relation to type of variability. (Distribution as: normal, log normal or other type of variability)	Sectoral
			DP.1.1.2	Uncertainty assessment for every data source as input to Data Storage level 2 in relation to scale of variability (size of variation intervals)	Sectoral

Level	CCP	Id	Description	
		DP.1.1.3	Evaluation of the methodological approach using international guidelines	Sectoral
		DP.1.1.4	Verification of calculation results using guideline values	Sectoral
	2.Comparability	DP.1.2.1	The inventory calculation has to follow the international guidelines suggested by UNFCCC and IPCC.	Sectoral
	3.Completeness	DP.1.3.1	Assessment of the most important quantitative knowledge, which is lacking.	Sectoral
		DP.1.3.2	Assessment of the most important cases where access is lacking with regard to critical data sources that could improve quantitative knowledge.	Sectoral
	4.Consistency	DP.1.4.1	In order to keep consistency at a high level, an explicit description of the activities needs to accompany any change in the calculation procedure	Sectoral
		DP.1.4.2	Identification of parameters (e.g. activity data, constants) that are common to multiple source categories and confirmation that there is consistency in the values used for these parameters in the emission calculations	General
	5.Correctness	DP.1.5.1	Shows at least once, by independent calculation, the correctness of every data manipulation	Sectoral
		DP.1.5.2	Verification of calculation results using time series	Sectoral
		DP.1.5.3	Verification of calculation results using other measures	Sectoral
		DP.1.5.4	Show one-to-one correctness between external data sources and the databases at Data Storage level 2	Sectoral
	6.Robustness	DP.1.6.1	Any calculation must be anchored to two responsible persons who can replace each other in the technical issue of performing the calculations.	General
	7.Transparency	DP.1.7.1	The calculation principle and equations used must be described	Sectoral
		DP.1.7.2	The theoretical reasoning for all methods must be described	Sectoral
		DP.1.7.3	Explicit listing of assumptions behind all methods	Sectoral
		DP.1.7.4	Clear reference to dataset at Data Storage level 1	Sectoral
		DP.1.7.5	A manual log to collect information about recalculations	Sectoral
Data Storage level 2	2.Comparability	DS.2.2.1	Comparison with other countries that are closely related to Denmark and explanation of the largest discrepancies	General
	5.Correctness	DS.2.5.1	Documentation of a correct connection between all data types at level 2 to data at level 1	Sectoral
		DS.2.5.2	Check if a correct data import to level 2 has been made	Sectoral
	6.Robustness	DS.2.6.1	All persons in the inventory work must be able to handle and understand all data at level 2.	General
	7.Transparency	DS.2.7.1	The time trend for every single parameter must be graphically available and easy to map	General
Data Processing level 2	1. Accuracy	DP.2.1.1	Documentation of the methodological approach for the uncertainty analysis	General
		DP.2.1.2	Quantification of uncertainty	General
	2.Comparability	DP.2.2.1	The inventory calculation has to follow the international guidelines suggested by UNFCCC and IPCC	General
	6.Robustness	DP.2.6.1	Any calculation at level 4 must be anchored to two responsible persons who can replace each other in the technical issue of performing the calculations.	General
	7.Transparency	DP.2.7.1	Reporting of the calculation principle and equations used	General
		DP.2.7.2	The reasoning for the choice of methodology for uncertainty analysis needs to be written explicitly.	General
Data Storage level 3	1. Accuracy	DS.3.1.1	Quantification of uncertainty	General
	5.Correctness	DS.3.5.1	Comparison with inventories of the previous years on the level of the categories of the CRF as well as on SNAP source categories. Any major changes are checked, verified, etc.	General
		DS.3.5.2	Total emissions, when aggregated to CRF source categories, are compared with totals based on SNAP source categories (control of data transfer).	General
		DS.3.5.3	Checking of time series of the CRF and SNAP source categories as they are found in the Corinair databases. Considerable trends and changes are checked and explained.	General

Level	CCP	Id	Description	
	7. Transparency	DS.3.7.1	The databases and other software used shall be clearly documented. The documentation should include a description that the appropriate data processing steps are correctly represented in the database; that data relationships are correctly represented in the database and that data fields are properly labelled and have the correct design specifications.	General
		DS.3.7.2	The documentation referred to under DS.3.7.1 should be archived at the same network folder as the program is located in.	General
Data Processing level 3	6. Robustness	DP.3.6.1	The process of generating the official submissions must be anchored by at least two responsible persons who can replace each other in the technical issue of generating CRF tables including of the aggregation of submissions for Denmark and Greenland.	General
	7. Transparency	DP.3.7.1	The databases and other software used shall be clearly documented. The documentation should include a description that the appropriate data processing steps are correctly represented in the database; that data relationships are correctly represented in the database and that data fields are properly labelled and have the correct design specifications.	General
	7. Transparency	DP.3.7.2	The documentation referred to under DP.3.7.1 should be archived at the same network folder as the program is located in.	General
Data Storage level 4	2.Comparability	DS.4.2.1	Description of similarities and differences in relation to other countries' inventories for the methodological approach.	General
	3.Completeness	DS.4.3.1	National and international verification including explanation of the discrepancies.	General
		DS.4.3.2	Check that the no sources where a methodology exists in the IPCC guidelines are reported as NE.	General
	4.Consistency	DS.4.4.1	The inventory reporting must follow the international guidelines suggested by UNFCCC and IPCC.	General
		DS.4.4.2	Check time series consistency of the reporting by Greenland and the Faroe Islands prior to aggregating the final submissions.	General
		DS.4.4.3	The IEFs from the CRF are checked regarding both level and trend. The level is compared to relevant emission factors to ensure correctness. Large dips/jumps in the time series are explained.	Sectoral
	5.Correctness	DS.4.5.1	Check that the aggregated submissions for Denmark under the Kyoto Protocol and the UNFCCC match the sum of the individual submissions.	General
		DS.4.5.2	Check that additional information and information related to land-use changes has been correctly aggregated compared to the individual submissions of Denmark and Greenland.	Sectoral
	6. Robustness	DS.4.6.1	The reporting to the UNFCCC must be anchored to two responsible persons who can replace each other in the technical issue of reporting to and communicating with the UNFCCC secretariat.	General
	7.Transparency	DS.4.7.1	Perform QA on the documentation report provided by the Government of Greenland.	General

1.6.7 Plan for the quality work

The IPCC uses the concept of a tiered approach, i.e. a stepwise approach, where complexity, advancement and comprehensiveness increase. Generally, more detailed and advanced methods are recommended in order to give guidance to countries, which have more detailed datasets and more capacity, as well as to countries with less available data and manpower. The tiered approach helps to focus attention on the areas of the inventories that are relatively weak, rather than investing effort in irrelevant areas. Furthermore, the IPCC guidelines recommend using higher tier methods for key categories in particular. Therefore, the identification of key categories is crucial for planning quality work. However, several issues regarding the listing of pri-

ority categories exist: (1) The contribution to the total emission figure (key source listing); (2) The contribution to the total uncertainty; (3) Most critical categories in relation to implementation of new methodologies and thus highest risk for miscalculations. All the points listed are necessary for different aspects of producing high quality work. These listings will be used to secure implementation of the full quality scheme for the most relevant categories. Verification in relation to other countries has been undertaken for priority categories.

1.6.8 Implementation of the QA/QC plan

The PMs listed in Table 1.2 are described for each sector in the QA/QC sections of Chapters 3-8, where a status with regard to implementation is also given. Some of the PMs are the same for all sectors and a common description for these PMs is given in Section 1.6.10, below. The focus has been on level 1 for both data storage and data processing as this is the most labour-intensive part. The quality system will be evaluated and adjusted continuously.

1.6.9 Archiving of data and documentations

The QA/QC work is supported by an inventory file system, where all data, models and QA/QC procedures and checks are stored as files in folders (Figure 1.4).



Figure 1.4 Schematic diagram of the folder structure in the inventory file system.

The inventory file system consists of the following levels: year, sector and the level for the process of the inventory work, as illustrated in Figure 1.4. The first level in the file system is year, which here means the inventory year and not the calendar year. The sector level contains the PMs relevant for the individual sectors i.e. the first levels (DS1 and DP1) (except the PMs de-

scribed in Section 1.6.10), while the rest of the PMs (DS2-4 and DP2-3), are common for all sectors.

All data, models and other QA/QC related files are stored in the inventory file system and are accessible for all staff involved in the inventory work.

1.6.10 Common QA/QC PMs

The following PMs are common for all the sectors:

Data storage Level 1

Data Storage level 1	6. Robustness	DS.1.6.2	At least two employees must have a detailed insight into the gathering of every external dataset.
----------------------	---------------	----------	---

For all sectors: energy, industrial processes and product use, agriculture, LULUCF and waste, two persons have detailed insight in data gathering and processing. A strong effort is continuously made to ensure the robustness of the inventory process.

Data Storage level 1	7. Transparency	DS.1.7.2	The archiving of datasets needs to be easily accessible for any person involved in the emission inventory.
----------------------	-----------------	----------	--

All data, models and other QA/QC related files are stored in the inventory file system and are accessible for all inventory staff members. Refer to Section 1.6.9.

Data processing Level 1

Data Processing level 1	4. Consistency	DP.1.4.2	Identification of parameters (e.g. activity data, constants) that are common to multiple source categories and confirmation that there is consistency in the values used for these parameters in the emission calculations.
-------------------------	----------------	----------	---

This PM is supported by the inventory file system where it is possible to compare and harmonise parameters that are common to multiple source categories.

Data Processing level 1	6. Robustness	DP.1.6.1	Any calculation must be anchored to two responsible persons who can replace each other in the technical issue of performing the calculations.
-------------------------	---------------	----------	---

All data, models and other QA/QC related files are stored in the inventory file system and are accessible for all inventory staff members. Refer to Section 1.6.9.

Data storage Level 2

Data Storage level 2	2. Comparability	DS.2.2.1	Comparison with other countries that are closely related to Denmark and explanation of the largest discrepancies.
----------------------	------------------	----------	---

Systematic inter-country comparison has only been made on data storage level 4. Refer to DS 4.3.2.

Data Storage level 2	6.Robustness	DS.2.6.1	All persons in the inventory work must be able to handle and understand all data at level 2.
----------------------	--------------	----------	--

This PM is fulfilled for all sectors. The PM is supported by the inventory file system. Refer to Section 1.6.9.

Data Storage level 2	7.Transparency	DS.2.7.1	The time trend for every single parameter must be graphically available and easy to map.
----------------------	----------------	----------	--

Programs exist to make time series for all parameters. A tool for graphically showing time series has not yet been developed.

Data Processing Level 2

Data Processing level 2	1. Accuracy	DP.2.1.1	Documentation of the methodological approach for the uncertainty analysis
-------------------------	-------------	----------	---

Refer to Chapter 1.7.

Data Processing level 2	1. Accuracy	DP.2.1.2	Quantification of uncertainty
-------------------------	-------------	----------	-------------------------------

Refer to Chapter 1.7 and the uncertainty sections in the sectoral chapters (Chapter 3-7).

Data Processing level 2	2.Comparability	DP.2.2.1	The inventory calculation has to follow the international guidelines suggested by UN-FCCC and IPCC.
-------------------------	-----------------	----------	---

The emission calculations follow the international guidelines.

Data Processing level 2	6.Robustness	DS.2.6.1	All persons in the inventory work must be able to handle and understand all data at level 2.
-------------------------	--------------	----------	--

At present, the emission calculations are carried out using applications developed at DCE. The software development and programme runs are anchored to two inventory staff members.

Data Processing level 2	7.Transparency	DP.2.7.1	Reporting of the calculation principle and equations used.
-------------------------	----------------	----------	--

Due to the uniform treatment of input data in the calculation routines used by the DCE software programmes, a central documentation of calculation principles, equations, theoretical reasoning and assumptions must be given, treating all national emission sources. This documentation remains to be made, but is planned to be carried out in the future.

Data Processing level 2	7.Transparency	DP.2.7.2	The reasoning for the choice of methodology for uncertainty analysis needs to be written explicitly.
-------------------------	----------------	----------	--

Refer to Chapter 1.7 and the QA/QC sections in the sectoral chapters.

Data storage Level 3

Data Storage level 3	1. Accuracy	DS.3.1.1	Quantification of uncertainty
----------------------	-------------	----------	-------------------------------

Refer to Chapter 1.7 and the QA/QC sections in the sector chapters.

Data Storage level 3	5. Correctness	DS.3.5.1	Comparison with inventories of the previous years on the level of the categories of the CRF as well as on SNAP source categories. Any major changes are checked, verified, etc.
----------------------	----------------	----------	---

Time series is prepared and checked, any major change is closely examined with the purpose of verifying and explaining changes from earlier inventories.

Data Storage level 3	5. Correctness	DS.3.5.2	Total emissions when aggregated to CRF source categories are compared with totals based on SNAP source categories (control of data transfer).
----------------------	----------------	----------	---

Total emission, when aggregated to IPCC and LRTAP reporting tables, is compared with totals based on SNAP source categories (control of data transfer).

Data Storage level 3	5. Correctness	DS.3.5.3	Checking of time series of the CRF and SNAP source categories as they are found in the Corinair databases. Considerable trends and changes are checked and explained.
----------------------	----------------	----------	---

Time series are prepared and checked, any major change is closely examined with the purpose of verifying and explaining fluctuations.

Data Storage level 3	7. Transparency	DS.3.7.1	The databases and other software used shall be clearly documented. The documentation should include a description that the appropriate data processing steps are correctly represented in the database; that data relationships are correctly represented in the database and that data fields are properly labelled and have the correct design specifications.
----------------------	-----------------	----------	--

The databases used at data storage level 3 are documented. The documentation includes description of the queries and programming code used in the data processing. The documentation further includes information on all data fields in the database and the design specifications. Part of the detailed documentation is built into the database while the overall documentation is prepared as a separate documentation note.

Data Storage level 3	7. Transparency	DS.3.7.2	The documentation referred to under DS.3.7.1 should be archived at the same network folder as the program is located in.
----------------------	-----------------	----------	--

The documentation prepared as part of DS.3.7.1 is archived in the same folder as the program is stored. For information on the file structure, please see Chapter 1.6.9.

Data Processing Level 3

Data Processing level 3	6. Robustness	DP.3.6.1	The process of generating the official submissions must be anchored by at least two responsible persons who can replace each other in the technical issue of generating CRF tables including of the aggregation of submissions for Denmark and Greenland.
-------------------------	---------------	----------	---

The process of generating the official submissions including the aggregation of submissions to the UNFCCC and the Kyoto Protocol is currently anchored by two people within the team. In the future, the goal is to have three team members capable of completing this task.

Data Processing level 3	7. Transparency	DP.3.7.1	The databases and other software used shall be clearly documented. The documentation should include a description that the appropriate data processing steps are correctly represented in the database; that data relationships are correctly represented in the database and that data fields are properly labelled and have the correct design specifications.
-------------------------	-----------------	----------	--

The databases used at data storage level 3 are documented. The documentation includes description of the queries and programming code used in the data processing. The documentation further includes information on all data fields in the database and the design specifications. Part of the detailed documentation is built into the database while the overall documentation is prepared as a separate documentation note.

Data Processing level 3	7. Transparency	DP.3.7.2	The documentation referred to under DS.3.7.1 should be archived at the same network folder as the program is located in.
-------------------------	-----------------	----------	--

The documentation prepared as part of DS.3.7.1 is archived in the same folder as the program is stored. For information on the file structure, please see Chapter 1.6.9.

Data Storage Level 4

Data Storage level 4	2.Comparability	DS.4.2.1	Description of similarities and differences in relation to other countries' inventories for the methodological approach
----------------------	-----------------	----------	---

For each key source category, a comparison has been made between Denmark and the EU-15 countries (Fauser et al., 2007 & 2013). This is performed by comparing emission density indicators, defined as emission intensity value divided by a chosen indicator. The indicators are identical to the ones identified in the Norwegian verification inventory (Holtskog et al., 2000). The correlation between emissions and an independent indicator does not necessarily imply cause and effect, but in cases where the indicator is directly associated with the emission intensity value, such as for the energy sector, the emission density indicator is a measure of the implied emission factor and a direct comparison can be made. A qualitative verification of implied

emission factors can be made when a measured or theoretical value of the CO₂ content in the respective fuel type (or other relevant parameter) is available. For the energy sector, all countries are, in principle, comparable and inter-country deviations arise from variations in fuel purities and fuel combustion efficiencies. A comparison of national emission density indicators, analogous to the implied emission factors, will give valuable information on the quality and efficiency of the national energy sectors.

Furthermore, the inter-country comparison of emission density indicators and comparison of theoretical values gives a methodological verification of the derivation of emission intensity values, and of the correlation between emission intensity values and activity values.

When emissions are compared with non-dependent parameters, similarities with regard to geography, climate, industry structure and level of economic development may be necessary for obtaining comparable emission density indicators.

Data Storage level 4	3.Completeness	DS.4.3.1	National and international validation including explanation of the discrepancies.
----------------------	----------------	----------	---

Refer to DS 4.2.1

Data Storage level 4	3.Completeness	DS.4.3.2	Check that the no sources where a methodology exists in the IPCC guidelines are reported as NE.
----------------------	----------------	----------	---

It is verified both by DCE experts and by EU consistency checks that no sources where methodologies and default parameters exist have been reported as NE. If methodologies do exist efforts are made to estimate and report emissions.

Data Storage level 4	4.Consistency	DS.4.4.1	The inventory reporting must follow the international guidelines suggested by UNFCCC and IPCC.
----------------------	---------------	----------	--

The inventory reporting is in accordance with the UNFCCC reporting guidelines (UNFCCC, 2013). The present report includes detailed and complete information on the inventories for all years from the base year to the year of the current annual inventory submission, in order to ensure the transparency of the inventory. The annual emission inventory for Denmark is reported in the Common Reporting Format (CRF) as requested in the reporting guidelines. The CRF-spreadsheets contain data on emissions, activity data and implied emission factors for each year. Emission trends are given for each greenhouse gas and for total greenhouse gas emissions in CO₂ equivalents. The link to complete sets of CRF-files and more information on the Danish emission inventories are on the ENVS homepage (<http://envs.au.dk/videnudveksling/luft/emissioner/emissioninventory>).

Data Storage level 4	4.Consistency	DS.4.4.2	Check time series consistency of the reporting of Greenland and the Faroe Islands prior to aggregating the final submissions.
----------------------	---------------	----------	---

The time series for all pollutants in the submissions from Greenland and the Faroe Islands are checked at the CRF 3 level for large variations in the time

series. Any large variations are explained or corrected in cooperation with the authorities in Greenland and the Faroe Islands.

Data Storage level 4	5. Correctness	DS.4.5.1	Check that the aggregated submissions for Denmark under the Kyoto Protocol and the UNFCCC matches the sum of the individual submissions.
----------------------	----------------	----------	--

To ensure that the submission for Denmark under the Kyoto Protocol matches the sum of the submissions of Denmark and Greenland a spreadsheet check has been implemented to ensure complete correctness of the submitted inventory. The same procedure is followed for the submission under the UNFCCC, where it is ensured that the submitted emissions equate to the sum of Denmark, Greenland and the Faroe Islands. Special attention is paid to the additional information provided in the CRF, e.g. for the agricultural sector. Certain parameters cannot simply be added, e.g. animal weights. In these cases, a weighted average is reported in the CRF tables.

Data Storage level 4	6. Robustness	DS.4.6.1	The reporting to the UNFCCC must be anchored to two responsible persons who can replace each other in the technical issue of reporting to and communicating with the UNFCCC secretariat.
----------------------	---------------	----------	--

The reporting to the UNFCCC secretariat is currently anchored by two team members. All official correspondence between the secretariat and DCE involves both the responsible team members.

Data Storage level 4	7. Transparency	DS.4.7.1	Perform QA on the documentation report provided by the Government of Greenland.
----------------------	-----------------	----------	---

The documentation report is received by DCE from the Government of Greenland in the early spring every year. The documentation report is included in the NIR as Chapter 16. DCE experts read and provide comments on the report to the Government of Greenland, so that any questions are resolved prior to the UNFCCC reporting deadline of April 15.

1.7 General uncertainty evaluation, including data on the overall uncertainty for the inventory totals

1.7.1 Tier 1 uncertainties

The uncertainty estimates are based on the Approach 1 methodology in the 2006 IPCC Guidelines (IPCC, 2006). Uncertainty estimates for all sectors are included in the current year. The sources included in the uncertainty estimate cover 100 % of the total net Danish greenhouse gas emissions and removals.

The uncertainties for the activity rates and emission factors are shown in Table 1.5.

Table 1.5 Summary of base year and 2020 emissions in kt CO₂ equivalents and activity data and emission factor uncertainties. Calculated Approach 1 uncertainties for each emission source are given as percentage of the total 2020 emission. The base year for F-gases is 1995 and for all other gases, the base year is 1990.

IPCC Source category	Gas	Base year	2020	Activity	Emission	Approach 1
		emission	emission	data	factor	Combined
		kt CO ₂ eqv	kt CO ₂ eqv.	uncertainty	uncertainty	uncertainty
				%	%	% of total emissions
1A Stationary combustion, Coal, ETS data, CO ₂	CO ₂	0.0	3392.3	0.5	0.3	0.583
1A Stationary combustion, Coal, no ETS data, CO ₂	CO ₂	23826.7	161.0	1.5	1.0	1.841
1A Stationary combustion, BKB, CO ₂	CO ₂	11.3	0.0	2.9	5.0	5.774
1A Stationary combustion, Coke oven coke, CO ₂	CO ₂	136.5	34.2	1.5	5.0	5.224
1A Stationary combustion, Fossil waste, ETS data, CO ₂	CO ₂	0.0	1371.0	2.0	3.0	3.606
1A Stationary combustion, Fossil waste, no ETS data, CO ₂	CO ₂	573.5	431.1	5.0	10.0	11.180
1A Stationary combustion, Petroleum coke, ETS data, CO ₂	CO ₂	0.0	694.2	0.5	0.5	0.707
1A Stationary combustion, Petroleum coke, no ETS data, CO ₂	CO ₂	414.7	21.6	1.9	5.0	5.336
1A Stationary combustion, Residual oil, ETS data, CO ₂	CO ₂	0.0	216.2	0.5	0.5	0.707
1A Stationary combustion, Residual oil, no ETS data, CO ₂	CO ₂	2526.6	22.6	1.0	2.0	2.220
1A Stationary combustion, Gas oil, CO ₂	CO ₂	4738.4	502.1	2.6	1.3	2.902
1A Stationary combustion, Kerosene, CO ₂	CO ₂	367.6	15.0	2.0	3.0	3.606
1A Stationary combustion, LPG, CO ₂	CO ₂	187.9	149.4	2.0	4.0	4.492
1A1b Stationary combustion, Petroleum refining, Refinery gas, CO ₂	CO ₂	816.1	910.5	1.0	0.5	1.118
1A Stationary combustion, Natural gas, onshore, CO ₂	CO ₂	3790.5	4787.9	1.3	0.4	1.358
1A1c_ii Stationary combustion, Oil and gas extraction, Off shore gas turbines, Natural gas, CO ₂	CO ₂	544.9	1206.1	0.5	0.5	0.707
1A1 Stationary Combustion, Solid fuels, CH ₄	CH ₄	5.3	0.8	1.0	100.0	100.005
1A1 Stationary Combustion, Liquid fuels, CH ₄	CH ₄	0.7	0.5	1.0	100.0	100.005
1A1 Stationary Combustion, not engines, gaseous fuels, CH ₄	CH ₄	0.8	1.5	1.0	100.0	100.005
1A1 Stationary Combustion, Waste, CH ₄	CH ₄	0.2	0.3	3.0	100.0	100.045
1A1 Stationary Combustion, not engines, Biomass, CH ₄	CH ₄	3.3	12.8	3.0	100.0	100.045
1A2 Stationary Combustion, solid fuels, CH ₄	CH ₄	3.8	1.1	2.0	100.0	100.020
1A2 Stationary Combustion, Liquid fuels, CH ₄	CH ₄	0.9	0.7	2.0	100.0	100.020
1A2 Stationary Combustion, not engines, gaseous fuels, CH ₄	CH ₄	0.6	0.7	2.0	100.0	100.020
1A2 Stationary Combustion, Waste, CH ₄	CH ₄	0.0	2.8	3.0	100.0	100.045
1A2 Stationary Combustion, not engines, Biomass, CH ₄	CH ₄	1.6	1.8	3.0	100.0	100.045
1A4 Stationary Combustion, Solid fuels, CH ₄	CH ₄	6.2	0.1	3.0	100.0	100.045
1A4 Stationary Combustion, Liquid fuels, CH ₄	CH ₄	3.0	0.3	3.0	100.0	100.045
1A4 Stationary Combustion, not engines, gaseous fuels, CH ₄	CH ₄	0.6	0.8	3.0	100.0	100.045
1A4 Stationary Combustion, Waste, CH ₄	CH ₄	0.7	0.0	3.0	100.0	100.045
1A4 Stationary Combustion, not engines, not residential wood and not residential/agricultural straw, Biomass, CH ₄	CH ₄	0.1	0.4	3.0	100.0	100.045
1A4b_i Stationary combustion, Residential wood combustion, CH ₄	CH ₄	72.3	44.1	10.0	150.0	150.333
1A4b_i/1A4c_i Stationary Combustion, Residential and agricultural straw combustion, CH ₄	CH ₄	63.6	36.5	10.0	150.0	150.333
1A Stationary combustion, Natural gas fuelled engines, gaseous fuels, CH ₄	CH ₄	5.5	78.2	1.0	2.0	2.236
1A Stationary combustion, Biogas fuelled engines, CH ₄	CH ₄	2.2	58.9	3.0	10.0	10.440

PCC Source category	Gas	Base year	2020	Activity data	Emission factor	Approach 1
		emission	emission	uncertainty	uncertainty	Combined uncertainty % of total emissions
		kt CO ₂ eqv.	kt CO ₂ eqv.	%	%	
Biomass, CH₄						
1A1 Stationary Combustion, Solid fuels, N ₂ O	N ₂ O	57.4	8.0	1.0	400.0	400.001
1A1 Stationary Combustion, Liquid fuels, N ₂ O	N ₂ O	2.8	1.4	1.0	1000.0	1000.000
1A1 Stationary Combustion, Gaseous fuels, N ₂ O	N ₂ O	11.8	13.1	1.0	750.0	750.001
1A1 Stationary Combustion, Waste, N ₂ O	N ₂ O	5.2	13.5	3.0	400.0	400.011
1A1 Stationary Combustion, Biomass, N ₂ O	N ₂ O	8.4	42.4	3.0	400.0	400.011
1A2 Stationary Combustion, Solid fuels, N ₂ O	N ₂ O	6.7	17.7	2.0	400.0	400.005
1A2 Stationary Combustion, Liquid fuels, N ₂ O	N ₂ O	28.7	6.6	2.0	1000.0	1000.002
1A2 Stationary Combustion, Gaseous fuels, N ₂ O	N ₂ O	7.2	7.9	2.0	750.0	750.003
1A2 Stationary Combustion, Waste, N ₂ O	N ₂ O	0.0	4.4	3.0	400.0	400.011
1A2 Stationary Combustion, Biomass, N ₂ O	N ₂ O	6.9	10.2	3.0	400.0	400.011
1A4 Stationary Combustion, Solid fuels, N ₂ O	N ₂ O	1.5	0.1	3.0	400.0	400.011
1A4 Stationary Combustion, Liquid fuels, N ₂ O	N ₂ O	11.4	1.1	3.0	1000.0	1000.004
1A4 Stationary Combustion, Gaseous fuels, N ₂ O	N ₂ O	7.7	9.7	3.0	750.0	750.006
1A4 Stationary Combustion, Waste, N ₂ O	N ₂ O	1.1	0.0	3.0	400.0	400.011
1A4 Stationary Combustion, not residential wood and not residential/agricultural straw, Biomass, N ₂ O	N ₂ O	0.5	4.2	3.0	400.0	400.011
1A4b_i Stationary Combustion, Residential wood combustion, N ₂ O	N ₂ O	10.7	38.6	10.0	500.0	500.100
1A4b_i/1A4c_i Stationary Combustion, Residential and agricultural straw combustion, N ₂ O	N ₂ O	10.1	5.8	10.0	500.0	500.100
1.A.2.g Industry (mobile)	CO ₂	629.3	596.1	41.0	5.0	41.304
1.A.3.a Civil aviation	CO ₂	224.1	149.5	10.0	5.0	11.180
1.A.3.b Road Transport	CO ₂	9356.7	12098.3	2.0	5.0	5.385
1.A.3.c Railways	CO ₂	296.7	223.6	2.0	5.0	5.385
1.A.3.d Navigation (large vessels)	CO ₂	714.4	514.2	11.0	5.0	12.083
1.A.4.a Commercial/Institutional (mobile)	CO ₂	44.6	79.0	35.0	5.0	35.355
1.A.4.b Residential (mobile)	CO ₂	18.8	21.8	35.0	5.0	35.355
1.A.4.c ii Agriculture (mobile)	CO ₂	1272.3	998.0	24.0	5.0	24.515
1.A.4.c ii Forestry (mobile)	CO ₂	35.7	15.0	30.0	5.0	30.414
1.A.4.c iii Fisheries	CO ₂	619.6	275.3	2.0	5.0	5.385
1.A.5.b Other (military)	CO ₂	47.9	97.4	41.0	5.0	41.304
1.A.5.b Other (small boats)	CO ₂	119.0	100.5	2.0	5.0	5.385
1.A.2.g Industry (mobile)	CH ₄	1.5	0.5	41.0	100.0	108.079
1.A.3.a Civil aviation	CH ₄	0.1	0.0	10.0	100.0	100.499
1.A.3.b Road Transport	CH ₄	78.4	8.8	2.0	40.0	40.050
1.A.3.c Railways	CH ₄	0.3	0.1	2.0	100.0	100.020
1.A.3.d Navigation (large vessels)	CH ₄	0.4	0.9	11.0	100.0	100.603
1.A.4.a Commercial/Institutional (mobile)	CH ₄	0.6	0.7	35.0	100.0	105.948
1.A.4.b Residential (mobile)	CH ₄	0.9	0.4	35.0	100.0	105.948
1.A.4.c ii Agriculture (mobile)	CH ₄	2.3	1.3	24.0	100.0	102.840
1.A.4.c ii Forestry (mobile)	CH ₄	4.0	0.4	30.0	100.0	104.403
1.A.4.c iii Fisheries	CH ₄	0.3	0.2	2.0	100.0	100.020
1.A.5.b Other (military)	CH ₄	1.9	0.2	41.0	100.0	108.079
1.A.5.b Other (small boats)	CH ₄	0.1	0.1	2.0	100.0	100.020
1.A.2.g Industry (mobile)	N ₂ O	7.4	8.3	41.0	1000.0	1000.840
1.A.3.a Civil aviation	N ₂ O	3.1	2.1	10.0	1000.0	1000.050
1.A.3.b Road Transport	N ₂ O	87.1	130.7	2.0	50.0	50.040
1.A.3.c Railways	N ₂ O	2.7	2.0	2.0	1000.0	1000.002
1.A.3.d Navigation (large vessels)	N ₂ O	5.3	3.9	11.0	1000.0	1000.060
1.A.4.a Commercial/Institutional (mobile)	N ₂ O	0.4	0.6	35.0	1000.0	1000.612

PCC Source category	Gas	Base year	2020	Activity data	Emission factor	Approach 1
		emission	emission	uncertainty	uncertainty	Combined
		kt CO ₂ eqv.	kt CO ₂ eqv.	%	%	uncertainty % of total emissions
1.A.4.b Residential (mobile)	N ₂ O	0.1	0.1	35.0	1000.0	1000.612
1.A.4.c ii Agriculture (mobile)	N ₂ O	14.7	14.2	24.0	1000.0	1000.288
1.A.4.c ii Forestry (mobile)	N ₂ O	0.2	0.2	30.0	1000.0	1000.450
1.A.4.c iii Fisheries	N ₂ O	4.7	2.1	2.0	1000.0	1000.002
1.A.5.b Other (military)	N ₂ O	0.4	1.0	41.0	1000.0	1000.840
1.A.5.b Other (small boats)	N ₂ O	1.1	1.1	2.0	1000.0	1000.002
1.B.2.a.1 Exploration	CO ₂	4.7	0.0	2.0	10.0	10.198
1.B.2.a.2 Production	CO ₂	0.0	0.0	2.0	100.0	100.020
1.B.2.a.4 Refining/storage	CO ₂	0.0	0.0	2.0	40.0	40.050
1.B.2.b.1 Exploration	CO ₂	8.2	0.0	2.0	10.0	10.198
1.B.2.b.2 Production	CO ₂	0.1	0.0	2.0	100.0	100.020
1.B.2.b.4 Transmission and storage	CO ₂	0.0	0.0	15.0	2.0	15.133
1.B.2.b.5 Distribution	CO ₂	0.0	0.0	25.0	10.0	26.926
1.B.2.c.1.ii Venting	CO ₂	0.0	0.0	15.0	2.0	15.133
1.B.2.c.2.i Flaring, oil	CO ₂	22.9	15.8	11.0	2.0	11.180
1.B.2.c.2.ii Flaring, gas	CO ₂	2.1	1.4	7.5	2.0	7.762
1.B.2.c.2.iii Flaring, combined	CO ₂	302.8	177.5	7.5	2.0	7.762
1.B.2.a.1 Exploration	CH ₄	0.0	0.0	2.0	125.0	125.016
1.B.2.a.2 Production	CH ₄	0.1	0.1	2.0	100.0	100.020
1.B.2.a.3 Transport	CH ₄	12.3	1.0	2.0	100.0	100.020
1.B.2.a.4 Refining/storage	CH ₄	30.6	19.7	1.0	200.0	200.002
1.B.2.b.1 Exploration	CH ₄	0.8	0.0	2.0	125.0	125.016
1.B.2.b.2 Production	CH ₄	48.8	28.9	2.0	100.0	100.020
1.B.2.b.4 Transmission and storage	CH ₄	3.6	3.5	15.0	2.0	15.133
1.B.2.b.5 Distribution	CH ₄	6.4	2.8	25.0	10.0	26.926
1.B.2.c.1.ii Venting	CH ₄	1.5	0.7	15.0	2.0	15.133
1.B.2.c.2.i Flaring, oil	CH ₄	0.2	0.1	11.0	15.0	18.601
1.B.2.c.2.ii Flaring, gas	CH ₄	0.3	0.0	7.5	2.0	7.762
1.B.2.c.2.iii Flaring, combined	CH ₄	28.6	18.9	7.5	125.0	125.225
1.B.2.a.1 Exploration, oil	N ₂ O	1.4	0.0	2.0	1000.0	1000.002
1.B.2.c.2.i Flaring, oil	N ₂ O	0.1	0.0	11.0	1000.0	1000.060
1.B.2.c.2.ii Flaring, gas	N ₂ O	0.0	0.0	7.5	1000.0	1000.028
1.B.2.c.2.iii Flaring, combined	N ₂ O	51.6	34.2	7.5	1000.0	1000.028
2A1 Cement production	CO ₂	882.4	1129.2	1.6	2.0	2.561
2A2 Lime production	CO ₂	105.4	33.7	1.4	4.0	4.228
2A3 Glass production	CO ₂	16.5	9.8	1.0	2.0	2.236
2A4a Ceramics	CO ₂	46.1	46.7	5.0	2.0	5.385
2A4b Other uses of soda ash	CO ₂	13.8	17.1	5.0	2.0	5.385
2A4d Other process uses of carbonates	CO ₂	17.5	13.5	4.0	2.0	4.472
2B10 Production of catalysts	CO ₂	0.6	1.5	5.0	5.0	7.071
2C1a Steel	CO ₂	30.3	0.0	5.0	10.0	11.180
2C5 Lead production	CO ₂	0.2	0.1	10.0	50.0	50.990
2D1 Lubricant use	CO ₂	49.7	31.7	5.0	10.0	11.180
2D2 Paraffin wax use	CO ₂	21.7	59.1	10.0	20.0	22.361
Paint Application	CO ₂	12.9	6.3	10.0	15.0	18.028
Degreasing, dry cleaning and electronics	CO ₂	0.0	0.0	10.0	15.0	18.028
Chemical products manufacturing or processing	CO ₂	19.4	13.3	10.0	15.0	18.028
Other use of solvents and related activities	CO ₂	52.0	32.5	10.0	20.0	22.361
Printing industry	CO ₂	0.0	0.0	10.0	15.0	18.028
Domestic solvent use (other than paint application)	CO ₂	9.3	5.8	10.0	15.0	18.028
2D3 Road paving with asphalt	CO ₂	0.6	0.8	5.0	75.0	75.166
2D3 Asphalt roofing	CO ₂	0.0	0.0	5.0	75.0	75.166

IPCC Source category	Gas	Base year	2020	Activity data	Emission factor	Approach 1
		emission	emission	uncertainty	uncertainty	Combined
		kt CO ₂ eqv.	kt CO ₂ eqv.	%	%	uncertainty % of total emissions
2D3 Urea based catalysts	CO ₂	0.0	9.2	5.0	10.0	11.180
2G4 Fireworks	CO ₂	0.1	0.2	5.0	50.0	50.249
2D2 Paraffin wax use	CH ₄	0.0	0.1	10.0	20.0	22.361
2D3 Road paving with asphalt	CH ₄	0.3	0.4	5.0	75.0	75.166
2G4 Fireworks	CH ₄	0.0	0.1	5.0	50.0	50.249
2G4 Tobacco	CH ₄	1.0	0.5	5.0	50.0	50.249
2G4 Charcoal	CH ₄	1.1	1.4	5.0	100.0	100.125
2B2 Nitric acid production	N ₂ O	1002.5	0.0	2.0	25.0	25.080
2D2 Paraffin wax use	N ₂ O	0.1	0.1	10.0	20.0	22.361
2G3a Medical application of N ₂ O	N ₂ O	11.3	11.3	25.0	20.0	32.016
2G3b N ₂ O as propellant for pressure and aerosol products	N ₂ O	5.3	4.9	100.0	150.0	180.278
2G4 Fireworks	N ₂ O	0.7	2.4	5.0	50.0	50.249
2G4 Tobacco	N ₂ O	0.3	0.1	5.0	50.0	50.249
2G4 Charcoal	N ₂ O	0.1	0.1	5.0	100.0	100.125
2E Electronics industry	HFCs	0.0	0.0	0.0	0.0	0.000
2F1 Refrigeration and air conditioning	HFCs	47.6	322.8	10.0	50.0	50.990
2F2 Foam blowing agents	HFCs	210.3	0.7	10.0	50.0	50.990
2F4 Aerosols	HFCs	0.0	12.3	10.0	50.0	50.990
2E Electronics industry	PFCs	0.0	1.1	10.0	50.0	50.990
2F1 Refrigeration and air conditioning	PFCs	0.6	0.0	10.0	50.0	50.990
2C4 Magnesium production	SF ₆	34.2	0.0	10.0	30.0	31.623
2G1 Electrical equipment	SF ₆	3.7	12.7	10.0	50.0	50.990
2G2 SF ₆ and PFCs from other product use	SF ₆	65.9	58.5	10.0	50.0	50.990
3A Enteric Fermentation	CH ₄	4039.5	3718.9	2.0	20.0	20.100
3B Manure Management	CH ₄	1853.1	2117.6	5.0	20.0	20.616
3F Field Burning of Agricultural Residues	CH ₄	2.2	3.9	25.0	50.0	55.902
3B Manure Management	N ₂ O	767.9	532.3	25.0	100.0	103.078
3B5 Atmospheric deposition	N ₂ O	198.1	127.8	16.0	100.0	101.272
3Da1 Inorganic N fertilizer	N ₂ O	1875.0	1113.5	3.0	100.0	100.045
3Da2a Animal manure applied to soils	N ₂ O	991.0	977.2	25.0	100.0	103.078
3Da2b Sewage sludge applied to soils	N ₂ O	14.6	17.2	15.0	100.0	101.119
3Da2c Other organic fertilizer applied to soils	N ₂ O	7.2	27.1	20.0	100.0	101.980
3Da3 Urine and dung deposited by grazing animals	N ₂ O	297.9	172.7	10.0	100.0	100.499
3Da4 Crop Residues	N ₂ O	569.3	692.0	25.0	100.0	103.078
3Da5 Mineralization	N ₂ O	164.9	62.6	50.0	100.0	111.803
3Da6 Cultivation of organic soils	N ₂ O	817.8	605.6	20.0	100.0	101.980
3Db1 Atmospheric deposition	N ₂ O	333.7	175.7	16.0	100.0	101.272
3Db2 Leaching	N ₂ O	536.7	367.1	20.0	100.0	101.980
3F Field Burning of Agricultural Residues	N ₂ O	0.7	1.2	25.0	50.0	55.902
3G Liming	CO ₂	565.5	181.4	5.0	100.0	100.125
3H Urea application	CO ₂	14.7	0.7	3.0	100.0	100.045
3I Other carbon-containing fertilizers	CO ₂	38.4	3.1	3.0	100.0	100.045
4.A.1 Forest land remaining forest land, Living biomass	CO ₂	-288.6	-271.3	5.0	2.0	5.385
4.A.1 Forest land remaining forest land, Dead organic matter	CO ₂	-127.0	-1059.9	5.0	3.3	5.983
4.A.1 Forest land remaining forest land, Mineral soils	CO ₂	0.0	0.0	5.0	2.0	5.385
4.A.1 Forest land remaining forest land, Organic soils	CO ₂	147.4	122.6	10.0	50.0	50.990
4.A.2 Land converted to forest land	CO ₂	-1015.0	-1372.6	10.0	8.7	13.280
4.B.1 Cropland remaining cropland, Living biomass	CO ₂	74.6	35.7	2.5	15.0	15.207
4.B.1 Cropland remaining cropland, Mineral soils	CO ₂	583.8	48.8	2.5	75.0	75.042
4.B.1 Cropland remaining cropland, Organic soils	CO ₂	3959.1	2614.4	3.3	50.0	50.109

IPCC Source category	Gas	Base year	2020	Activity data	Emission factor	Approach 1
		emission	emission	uncertainty	uncertainty	Combined uncertainty % of total emissions
		kt CO ₂ eqv.	kt CO ₂ eqv.	%	%	
4.B.2 Forest land converted to cropland	CO ₂	2.2	26.3	10.0	50.0	50.990
4.B.2 Other land uses converted to cropland	CO ₂	86.3	-20.7	10.0	50.0	50.990
4(II) Cropland on organic soils	CO ₂	106.7	72.3	3.3	40.0	40.136
4.C.1 Grassland remaining grassland, Living biomass	CO ₂	7.5	60.9	2.5	7.0	7.433
4.C.1 Grassland remaining grassland, Organic soils	CO ₂	1974.2	1847.2	3.3	50.0	50.109
4.C.2 Forest land converted to grassland	CO ₂	2.4	6.1	10.0	50.0	50.990
4.C.2 Other land uses converted to grassland	CO ₂	53.7	38.5	10.0	50.0	50.990
4(II) Grassland on organic soils	CO ₂	72.9	68.4	3.3	40.0	40.136
4.D.1.1 Peat extraction remaining peat extraction	CO ₂	99.5	29.7	10.0	75.0	75.664
4.D.1.2 Flooded land remaining flooded land	CO ₂	0.0	0.0	10.0	75.0	75.664
4.D.2. Land converted to wetlands	CO ₂	9.3	14.3	10.0	75.0	75.664
4.E.2 Forest land converted to settlements	CO ₂	4.4	31.3	10.0	75.0	75.664
4.E.2 Other land uses converted to settlements	CO ₂	424.0	174.7	10.0	75.0	75.664
4.G Harvested wood products	CO ₂	-2.4	-334.5	25.0	75.0	79.057
4(II) Cropland on organic soils	CH ₄	136.7	97.1	10.0	90.0	90.554
4(II) Grassland on organic soils	CH ₄	119.0	111.6	10.0	90.0	90.554
4(II) A. Forest land, organic soils	CH ₄	4.3	3.1	10.0	90.0	90.554
4(II) Land converted to wetlands	CH ₄	0.5	26.2	10.0	90.0	90.554
4(II) Peatland	CH ₄	1.3	0.7	10.0	90.0	90.554
4(V) Biomass Burning	CH ₄	0.7	0.0	10.0	30.0	31.623
4(III) Mineralization/immobilization, Forest land	N ₂ O	0.0	0.0	10.0	90.0	90.554
4(III) Mineralization/immobilization, Cropland	N ₂ O	0.1	3.5	10.0	90.0	90.554
4(III) Mineralization/immobilization, Grassland	N ₂ O	0.0	0.1	10.0	90.0	90.554
4(III) Mineralization/immobilization, Land converted to Settlements	N ₂ O	43.8	16.9	10.0	90.0	90.554
4(V) Biomass burning	N ₂ O	0.4	0.0	10.0	30.0	31.623
4(II) Drainage and rewetting, Forest soils	N ₂ O	26.3	20.5	10.0	50.0	50.990
4(II) Peat extraction remaining peat extraction	N ₂ O	0.2	0.1	10.0	50.0	50.990
5.E Accidental fires	CO ₂	21.7	23.0	10.0	300.0	300.167
5.A Solid waste disposal	CH ₄	1536.3	534.2	10.0	104.5	105.000
5.B.1 Composting	CH ₄	26.7	86.4	20.0	100.0	101.980
5.B.2. Anaerobic digestion at biogas facilities	CH ₄	5.6	320.8	5.0	20.0	20.616
5.C.1 Incineration of corpses	CH ₄	0.0	0.0	1.0	150.0	150.003
5.C.2 Incineration of carcasses	CH ₄	0.0	0.0	40.0	150.0	155.242
5.D.1 Domestic wastewater	CH ₄	41.1	52.4	30.0	50.0	58.310
5.E Accidental fires	CH ₄	2.7	2.8	10.0	500.0	500.100
5.B.1 Composting	N ₂ O	22.2	74.3	20.0	100.0	101.980
5.C.1 Incineration of corpses	N ₂ O	0.2	0.2	1.0	150.0	150.003
5.C.2 Incineration of carcasses	N ₂ O	0.0	0.1	40.0	150.0	155.242
5.D.1 Domestic wastewater	N ₂ O	112.5	131.8	30.0	50.0	58.310
5.D.2 Industrial wastewater	N ₂ O	126.6	11.7	30.0	50.0	58.310

1.7.2 Results of the Approach 1 uncertainty estimation

The estimated uncertainties for total GHG and for CO₂, CH₄, N₂O and F-gases are shown in Table 1.6. The base year for F-gases is 1995 and for all other sources, the base year is 1990. The total Danish net GHG emission is estimated with an uncertainty of ±14.0 % and the trend in net GHG emission since the base year has been estimated to be -42.2 % ± 3.1 %-age points. The GHG uncertainty estimates do not take into account the uncertainty of the GWP factors.

The uncertainty of N₂O emissions from synthetic fertiliser, animal waste applied to soil and crop residues and CH₄ emission from solid waste disposal, are the largest sources of uncertainty for the Danish GHG inventory (excluding LULUCF). For LULUCF the largest sources of uncertainty are organic soil emissions from cropland.

The uncertainty of the GHG emission from combustion (sector 1A) is 2.9 % and the trend uncertainty is -48.2 % ±1.4 %-age points.

Table 1.6 Uncertainties 1990-2020.

	Uncertainty Base year [%]	Uncertainty 2020 [%]	Trend [%]	Uncertainty in trend [%-age points]
GHG	10.9	14.0	-42.2	3.1
CO ₂	4.3	5.7	-48.3	1.6
CH ₄	22.8	14.3	-10.0	11.3
N ₂ O	90.9	101.7	-32.3	20.9
F-gases	31.9	43.6	4.9	50.3
CO ₂ excl. LULUCF	1.8	2.6	-47.2	1.2
GHG excl. LULUCF	11.4	14.5	-41.0	3.2

The overall increase in the uncertainty from the base year to the latest year is caused by less uncertain emission sources (such as CO₂ emission from fossil fuels) declining significantly. This causes more uncertain emission sources such as agriculture and LULUCF to influence the overall uncertainty more.

1.7.3 Tier 2 uncertainties

On the recommendation of the UNFCCC expert review team (ERT) in 2009 Denmark undertook a tier 2 uncertainty analysis. However, due to a reduction in resources, the tier 2 uncertainty analysis will no longer be carried out. For a description on the methodology and results of the tier 2 uncertainty estimation, please refer to Nielsen et al. (2016).

1.8 General assessment of the completeness

The present Danish greenhouse gas emission inventory includes all sources identified by the 2006 IPPC Guidelines. Please see Annex 5 for discussion on minor sources that are not included.

1.9 ETS emissions

The table below includes data for the share of national total emissions covered by the EU ETS (not including aviation) for 2013-2020. As neither Greenland nor the Faroe Islands are members of the EU, the data in Table 1.7 refer to Denmark only.

Table 1.7 Share of ETS emissions.

	2013	2014	2015	2016	2017	2018	2019	2020
National total emission without LULUCF with indirect, kt CO ₂ e	55 759	51 552	48 942	50 952	48 638	48 422	44 504	41 746
ETS emission, kt CO ₂ e	21 627	18 389	15 796	17 219	15 078	14 948	12 040	10 832
Share of ETS emission, %	38.8	35.7	32.3	33.8	31.0	30.9	27.1	25.9

1.10 References

Albrektsen, R., Mikkelsen, M.H. & Gyldenkærne, S. 2017: Danish emission inventories for agriculture. Inventories 1985 – 2015. Aarhus University, DCE – Danish Centre for Environment and Energy, 190 pp. Scientific Report from DCE – Danish Centre for Environment and Energy No. 250. Available at: <http://dce2.au.dk/pub/SR250.pdf>

DEPA, 2020: Waste Statistics 2019. Affaldsstatistik 2019. Unpublished.

DEPA, 2021: The greenhouse gases HFCs, PFCs and SF₆. Danish consumption and emissions 2019. Tomas Sander Poulsen, Provice. In press.

EMEP/CORINAIR, 2007: EMEP/CORINAIR Atmospheric Emission Inventory Guidebook – 2007, prepared by the UNECE/EMEP Task Force on Emissions Inventories and Projections. Technical Report No 16/2007. Available at: <http://www.eea.europa.eu/publications/EMEPCORINAIR5> (07-02-2021).

EEA, 2019: EMEP/EEA air pollutant emission inventory guidebook 2019. Technical guidance to prepare national emission inventories. EEA Report 13/2019. Available at: <https://www.eea.europa.eu/publications/emep-eea-guidebook-2019> (07-02-2021).

EU Commission, 2004: COMMISSION DECISION of 29 January 2004 establishing guidelines for the monitoring and reporting of greenhouse gas emissions pursuant to Directive 2003/87/EC of the European Parliament and of the Council. Available at: <http://eurlex.europa.eu/LexUriServ/LexUriServ.do?uri=OJ:L:2004:059:0001:0074:EN:PDF> (07-02-2021).

EU Commission, 2012: COMMISSION REGULATION (EU) No 601/2012 of 21 June 2012 on the monitoring and reporting of greenhouse gas emissions pursuant to Directive 2003/87/EC of the European Parliament and of the Council. Available at: <http://eur-lex.europa.eu/legal-content/EN/TXT/PDF/?uri=CELEX:32012R0601&from=EN> (07-02-2021).

EU Commission, 2018: COMMISSION IMPLEMENTING REGULATION (EU) 2018/2066 of 19 December 2018 on the monitoring and reporting of greenhouse gas emissions pursuant to Directive 2003/87/EC of the European Parliament and of the Council and amending Commission Regulation (EU) No 601/2012. Available at: <https://eur-lex.europa.eu/legal-content/EN/TXT/PDF/?uri=CELEX:32018R2066&from=EN> (07-02-2021)

Fausser, P., Thomsen, M., Nielsen, O-K., Winther, M., Gyldenkærne, S., Hoffmann, L., Lyck, E. & Illerup, J.B. 2007: Verification of the Danish emission inventory data by national and international data comparisons. National Environmental Research Institute, University of Aarhus, Denmark. 53 pp. – NERI Technical Report no. 627. Available at: http://www2.dmu.dk/pub/fr627_final.pdf

Fausser, P., Nielsen, M., Winther, M., Plejdrup, M., Gyldenkærne, S., Mikkelsen, M.H., Albrektsen, R., Hoffmann, L., Thomsen, M., Hjelgaard, K. & Nielsen, O.-K., 2013: Verification of the Danish 1990, 2000 and 2010 emission inventory data. Aarhus University, DCE – Danish Centre for Environment and Energy, 85 pp. Scientific Report from DCE – Danish Centre for Environment and Energy No. 79. Available at: <http://dce2.au.dk/pub/SR79.pdf>

Holtskog, S., Haakonsen, G., Kvingedal, E., Rypdal, K. & Tornsjø, B., 2000: Verification of the Norwegian emission inventory – Comparing emission intensity values with similar countries. The Norwegian Pollution Control Authority in cooperation with Statistics Norway. SFT report 1736/2000.

Illerup, J.B., Lyck, E., Winther, M. & Rasmussen, E. 2000: Denmark's National Inventory Report – Submitted under the United Nations Framework Convention on Climate Change. Emission Inventories. Research Notes from National Environmental Research Institute, Denmark no. 127, 326 pp. Available at:

http://www.dmu.dk/1_viden/2_Publikationer/3_arbrapporter/rapporter/ar127.pdf

IPCC, 2006: 2006 IPCC Guidelines for National Greenhouse Gas Inventories, Prepared by the National Greenhouse Gas Inventories Programme, Eggleston H.S., Buendia L., Miwa K., Ngara T. & Tanabe K. (eds). Published: IGES, Japan. Available at: <http://www.ipcc-nggip.iges.or.jp/public/2006gl/index.html> (07-02-2021).

IPCC, 2007: Climate Change 2007: The Physical Science Basis. Contribution of Working Group I to the Fourth Assessment Report of the Intergovernmental Panel on Climate Change [Solomon, S., D. Qin, M. Manning, Z. Chen, M. Marquis, K.B. Averyt, M. Tignor and H.L. Miller (eds.)]. Cambridge University Press, Cambridge, United Kingdom and New York, NY, USA, 996 pp. Available at:

https://www.ipcc.ch/publications_and_data/ar4/wg1/en/contents.html (07-02-2021).

IPCC, 2021: Summary for Policymakers. In: Climate Change 2021: The Physical Science Basis. Contribution of Working Group I to the Sixth Assessment Report of the Intergovernmental Panel on Climate Change [Masson-Delmotte, V., P. Zhai, A. Pirani, S. L. Connors, C. Péan, S. Berger, N. Caud, Y. Chen, L. Goldfarb, M. I. Gomis, M. Huang, K. Leitzell, E. Lonnoy, J.B.R. Matthews, T. K. Maycock, T. Waterfield, O. Yelekçi, R. Yu and B. Zhou (eds.)]. Cambridge University Press. In Press.

Nielsen, O.-K., Plejdrup, M.S., Winther, M., Gyldenkerne, S., Thomsen, M., Fauser, P., Nielsen, M. Mikkelsen, M.H., Albrektsen, R., Hjelgaard, K., Hoffmann, L. & Bruun, H.G., 2013: Quality manual for the Danish greenhouse gas inventory. Version 2. Aarhus University, DCE – Danish Centre for Environment and Energy, 44 pp. Scientific Report from DCE – Danish Centre for Environment and Energy No. 47. Available at:

<http://www.dmu.dk/Pub/SR47.pdf>

Nielsen, O.-K., Plejdrup, M.S., Winther, M., Nielsen, M., Gyldenkerne, S., Mikkelsen, M.H., Albrektsen, R., Thomsen, M., Hjelgaard, K., Fauser, P., Bruun, H.G., Johannsen, V.K., Nord-Larsen, T., Vesterdal, L., Callesen, I., Schou, E., Suadicani, K., Rasmussen, E., Petersen, S.B., Baunbæk, L. & Hansen, M.G. 2016. Denmark's National Inventory Report 2015 and 2016. Emission Inventories 1990-2014 - Submitted under the United Nations Framework Convention on Climate Change and the Kyoto Protocol. Aarhus University, DCE –Danish Centre for Environment and Energy, 943pp. Scientific Report from DCE – Danish Centre for Environment and Energy. Available at: <http://dce2.au.dk/pub/SR189.pdf>

Nielsen, O.-K., Plejdrup, M.S., Winther, M., Gyldenkærne, S., Thomsen, M., Nielsen, M., Mikkelsen, M.H., Albrektsen, R., Hjelgaard, K. & Bruun, H.G. 2020. Quality manual for the Danish greenhouse gas inventory. Version 3. Aarhus University, DCE - Danish Centre for Environment and Energy, 44 pp. Scientific Report No. 406. Available at: <http://dce2.au.dk/pub/SR406.pdf>

Pulles, T., Mareckova, K., Svetlik, J., Linek, M., & Skakala, J. 1999: CollectER -Installation and User Guide, EEA Technical Report No 31.

Statistics Denmark, 2020: Agriculture Statistics 2019. Denmark.

Sørensen, P.B., Illerup, J.B., Nielsen, M., Lyck, E., Bruun, H.G., Winther, M., Mikkelsen, M.H. & Gyldenkærne, S. 2005: Quality manual for the greenhouse gas inventory. Version 1. National Environmental Research Institute. - Research Notes from NERI 224: 25 pp. (electronic). Available at: http://www2.dmu.dk/1_viden/2_Publikationer/3_arbrapporter/rapporter/AR224.pdf

UNFCCC, 2013: Revision of the UNFCCC reporting guidelines on annual inventories for Parties included in Annex I to the Convention. UNFCCC Decision 24/CP.19.

2 Trends in greenhouse gas emissions

The trends presented in this Chapter cover the emissions from Denmark. Due to the small emissions originating from Greenland the trends are very similar in fact close to identical. A trend discussion of the aggregated greenhouse gas emissions from Denmark and Greenland is included in Chapter 17.1.

2.1 Description and interpretation of emission trends for aggregated greenhouse gas emissions

2.1.1 Greenhouse Gas Emissions

The greenhouse gas emissions are estimated according to the IPCC guidelines and are aggregated into five main sectors. The greenhouse gases include CO₂, CH₄, N₂O, HFCs, PFCs, SF₆ and NF₃. Figure 2.1 shows the estimated total greenhouse gas emissions in CO₂ equivalents from 1990 to 2020. The emissions are not corrected for electricity trade or temperature variations.

CO₂ is the most important greenhouse gas contributing in 2020 to the national total in CO₂ equivalents excluding LULUCF (Land Use and Land Use Change and Forestry) and excluding indirect CO₂ emissions with 68.1%, followed by CH₄ with 17.1 %, N₂O with 13.8 %, and f-gases (HFCs, PFCs, SF₆ and NF₃) with 0.9 %. The energy sector and agricultural sector represent the largest sources, followed by industrial processes and product use and waste, see Figure 1. The total national greenhouse gas emission in CO₂ equivalents excluding LULUCF has decreased by 41.3 % from 1990 to 2020 when considering indirect CO₂, if excluding indirect CO₂ the emissions have decreased by 40.7 %. The emissions including LULUCF and indirect CO₂ have decreased by 42.5 % from 1990 to 2020. Comments on the overall trends etc. seen in Figure 1 are given in the sections below on the individual greenhouse gases.

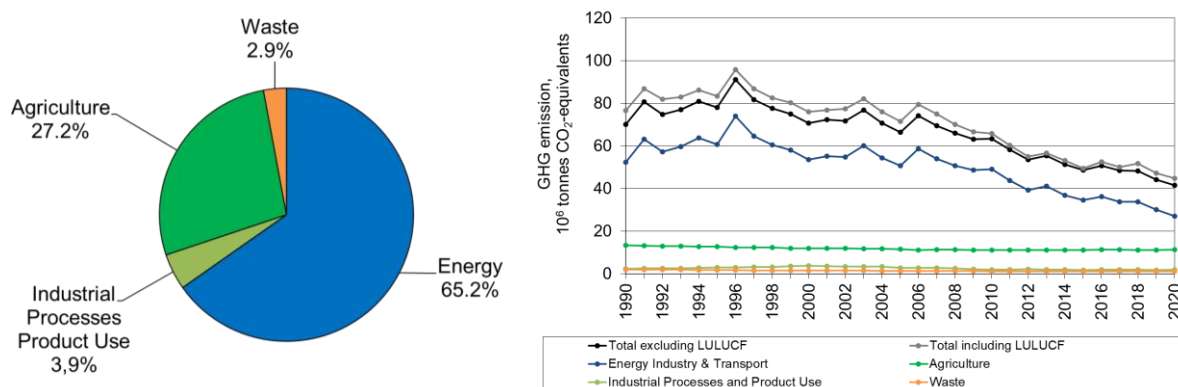

Figure 2.1 Greenhouse gas emissions in CO₂ equivalents distributed on main sectors for 2020 (excluding LULUCF and indirect CO₂) and time series for 1990 to 2020.

2.2 Description and interpretation of emission trends by gas

2.2.1 Carbon dioxide

The largest source to the emission of CO₂ is the energy sector, which includes combustion of fossil fuels like oil, coal and natural gas (Figure 2.2). The transport sector (dominated by road transport) is the largest sector in 2020 and contributes with 42 %, followed by energy industries with 25 %. The CO₂ emission (excl. LULUCF) decreased by 9.6 % from 2019 to 2020. The main reason for this large decrease is decreasing emissions across all sectors due to a decrease in the consumption of fossil fuels. Especially, the emissions from energy industries and transport were much lower in 2020 due to a significant lower consumption of fossil fuels, in particular a low consumption of coal and gasoline/diesel for road transport. The reduction in transport was to a large extent a result of the restrictions imposed during 2020 to combat the COVID-19 pandemic. In addition, there was considerable import of electricity in 2020; in fact, the electricity import was at its highest level since 1990. In general, CO₂ emissions fluctuate significantly as a result of the electricity trade with neighbouring countries.

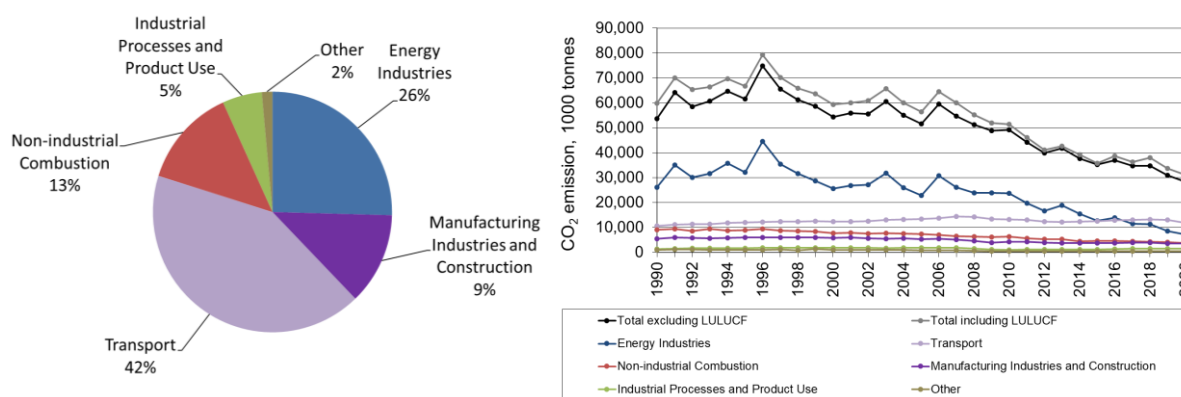

Figure 2.2 CO₂ emissions. Distribution according to the main sectors for 2020 and time series for 1990 to 2020.

2.2.2 Methane

The largest sources of anthropogenic CH₄ emissions are agricultural activities contributing with 82.6 % in 2020, waste (13.6 %) and the remaining emission sources covers 3.8 % - see Figure 2.3. The emission from agriculture derives from enteric fermentation (51.7 %) and management of animal manure (30.9 %).

Since 1990, the emission of CH₄ from enteric fermentation has decreased 8.8 % mainly due to the decrease in the number of cattle. However, this reduction is countered by an increase of 18.9 % in emissions from manure management caused by a change in housing type towards slurry-based systems. In later years, the emission from manure management has decreased due to changes in manure management, e.g. more biogas treatment and acidification of slurry. The emission of CH₄ from solid waste disposal has decreased significantly (65.2 %) from 1990 to 2020 due to an increase in the incineration of waste and extensive recycling thereby causing a decrease in the waste disposal on land. The CH₄ emission from the energy sector increases from mid 1990ties from public power and district heating plants increases due to the increasing use of gas engines in the decentralised cogeneration plant sector. Due to the liberalisation of the electricity market the use of gas engines declined from 2005 onwards. The high emission from gas engines is caused

by the fact that up to 3 % of the natural gas in the gas engines is not combusted.

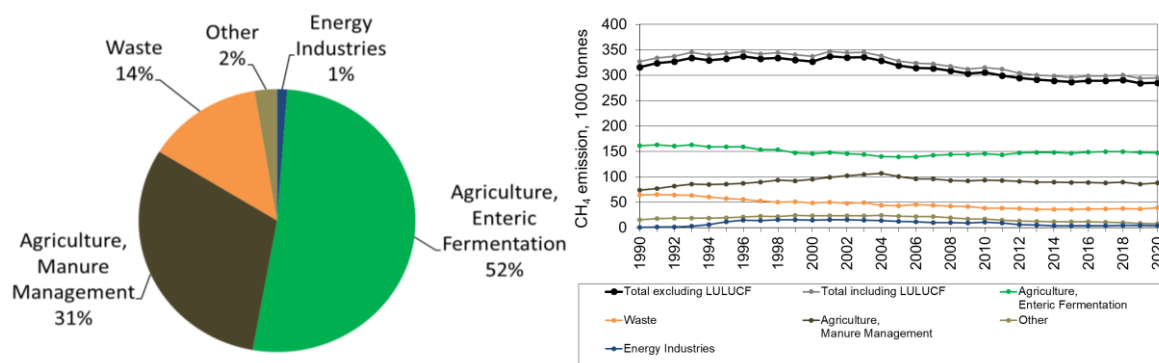

Figure 2.3 CH₄ emissions. Distribution according to the main sectors for 2020 and time series for 1990 to 2020.

2.2.3 Nitrous oxide

Agriculture is the most important N₂O emission source in 2020 contributing with 89.6 % (Figure 2.4) of which N₂O from soils dominates (77.9 % of total N₂O). Substantial emissions come from drainage water and coastal waters where nitrogen is converted to N₂O through bacterial processes. However, the nitrogen converted in these processes originates mainly from the agricultural use of manure and fertilisers.

The main reason for the decrease of N₂O emission is due to the agricultural sector, which has decreased with 24.8 % since 1990 caused by legislation to improve the utilisation of nitrogen in manure. Combustion of fuels contributes 6.2 % to the total whereof the N₂O emission from transport contributes with 2.3 % to the national total in 2020. Emission from industrial processes decreased significantly in 2004 due to the closure of the only nitric acid plant operating in Denmark and the emission from this emission source is therefore close to zero since then.

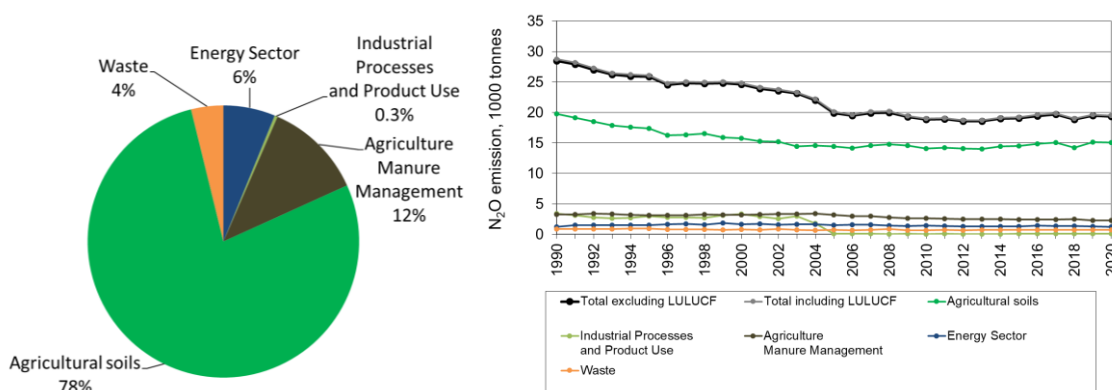

Figure 2.4 N₂O emissions. Distribution according to the main sectors for 2020 and time series for 1990 to 2020.

2.2.4 HFCs, PFCs, SF₆ and NF₃

This part of the Danish inventory only comprises a full data set for all substances from 1995 - see Figure 2.5. From 1995 to 2000, there was a continuous and substantial increase in the contribution from the range of f-gases as a whole (133.4 %), calculated as the sum of emissions in CO₂ equivalents. In 2000-2009, the increase of f-gas emissions continues with a lower increasing rate than for the years 1995 to 2000. Hereafter, the f-gas emission decreases.

The use of HFCs has increased several folds and HFCs have become the dominant f-gases, comprising 71.2 % in 1995 but 88.0 % in 2020. HFCs are mainly used as a refrigerant. SF₆ contributed considerably to the f-gas sum in earlier years, with 28.6 % in 1995 and reduced to 12.0 % in 2020. Due to environmental awareness the Danish legislation regulates the use of f-gases, e.g. since January 1, 2007 new HFC-based refrigerant stationary systems are forbidden. Refill of old systems are still allowed and the use of air conditioning in mobile systems increases.

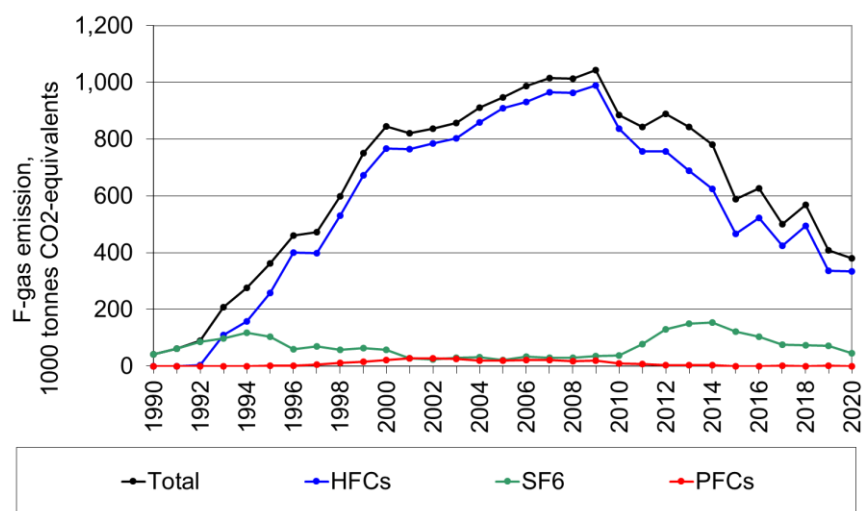

Figure 2.5 F-gas emissions. Time series for 1990 to 2020.

2.3 Description and interpretation of emission trends by source

2.3.1 Energy

The emission from the energy sector in 2020 covers 65.3 % of the total emission in CO₂ equivalents (excl. LULUCF and indirect CO₂). The emission of CO₂ equivalents from energy industries (CRF 1A1) has decreased by 72.0 % from 1990 to 2020. The relatively large fluctuations in the emission through the time-series 1990-2020 is due to inter-country electricity trade. Thus, the high emissions in 1991, 1996, 2003 and 2006 reflect a large electricity export and the low emission in 1990, 2005, 2008, 2011 and 2012 is due to import of electricity. In general, CO₂ emissions are decreasing due to a lower consumption of fossil fuels and a higher electricity production based on renewable energy, mainly wind power.

The increasing emission of CH₄ is due to the increasing use of gas engines in decentralised cogeneration plants. However, in later years the CH₄ emission has decreased due to less use of natural gas in gas engines. The CH₄ emission from residential combustion (mainly wood) increased as a result of increased use of wood. However, the wood consumption has decreased substantially over the last years, so that emission is decreasing. The emission of CO₂ equivalents from the transport sector (CRF 1A3) increased by 11.5 % from 1990 to 2020, mainly due to increasing road traffic. A large decrease in transport emissions occurred between 2019 and 2020, which can to a large extent be attributed to the restrictions to mobility in battling the COVID-19 pandemic.

2.3.2 Industrial processes and product use

The emissions from industrial processes and product use, i.e. emissions from processes other than fuel combustion, amount in 2020 to 4.6 % of the total emission in CO₂ equivalents (excl. LULUCF and indirect CO₂). The main sources are cement production and f-gases used in refrigeration and air conditioning.

The largest source is CO₂ emission from cement production, which in 2020 contributes with 1227.0 kt CO₂, i.e. 3.0 % of the national greenhouse gas emissions. The CO₂ emission from cement production has increased by 39.0 % since 1990. The second largest source is the emission from consumption of HFCs mainly from refrigeration and air condition equipment. This source contributes with 334.6 kt CO₂ equivalents, i.e. 0.8 % of the national total. Historically (1990-2004), the emission of N₂O from the production of nitric acid has been the second largest source (after cement), with up to 1002.5 kt CO₂ equivalents (1990). However, the production of nitric acid ceased in 2004, which reduced the N₂O emission from industrial processes drastically.

2.3.3 Agriculture

The agricultural sector contributes in 2020 with 27.1 % of the total emission in CO₂ equivalents (excl. LULUCF and indirect CO₂) and the major part is related to the livestock production. Since 1990, the agricultural emission has decreased 15.5 % mainly due to a decrease in the N₂O emission.

In 2020, the agricultural activities accounts for 82.6 % of the total CH₄ emission (excl. LULUCF). Since 1990, the emission of CH₄ from enteric fermentation has decreased by 8.9 %, which is mainly due to the decrease in the number of dairy cattle. However, the emission from manure management has in the same period increased 18.5 %, which is mainly driven by a change from traditional housing systems towards slurry-based housing systems. In total, the CH₄ emission from the agriculture sector 1990 – 2020 has decreased 0.3 %.

In 2020, the agricultural activities accounts for 89.6 % of the total N₂O emission (excl. LULUCF). Since 1990, the N₂O emission has decreased 24.8 %. A string of measures have been introduced by action plans to prevent the loss of nitrogen from agriculture to the aquatic environment. These actions have brought a decrease in animal nitrogen excretion, improvement in use of nitrogen in manure and a fall in the use of inorganic N fertiliser, which all have led to reductions of the N₂O emission.

2.3.4 Land use, Land-use change and forestry

The total sector has been estimated to be a net source of 4.3 % of the total Danish emission incl. LULUCF (average 2013-2020 (variation 1.6-7.2 % depending of year). The average emission in 2013-2020 has been estimated to 2145 kt CO₂ equivalents with an emission of 3107 kt CO₂ equivalents in 2020. Emissions/removals from the sector fluctuate based on specific conditions in the given year. In general, the forest sector is a net sink or around in its equilibrium state, while Cropland and Grassland are net sources. The latter due to a large area with drained organic soils. Emissions from drained organic agricultural soils in 2020 accounts for 9.9 % of the total Danish emission incl. LULUCF. Forest has shown to be a sink for all years since 1990. Since 2013,

forest has been estimated to be an average annual net sink of 2980 kt CO₂ equivalents.

In 2020, Cropland has been estimated to be a net source of 6.4 % of the total Danish emission incl. LULUCF. Grassland is a net source contributing to 5.0 % of the total Danish emission, also due to a large area with drained organic soils. Emissions from Cropland and Grassland have shown a continuous decrease since 1990. However, large variations occur between years.

2.3.5 Waste

The waste sector contributes in 2020 to 2.9 % of the total emission in CO₂ equivalents (excl. LULUCF and indirect CO₂). The emission from the sector has decreased by 36.2 % since 1990. The most important activity in the sector is solid waste disposal on land with CH₄ emissions contributing in 2020 to 44.4 % of the sectoral total GHG emission.

The CH₄ emission from solid waste disposal has been decreasing since 1990 by 65.1 % due to banning of depositing organic waste and an overall decrease in waste deposited because waste has increasingly been used for power and heat production and/or recycled.

Biological treatment of solid waste (5.B) is the second largest contributor to the sectoral total GHG emission in 2020. It contributes to the sectoral total in CO₂ equivalents in 2020 with 37.0 %. The emissions from biological treatment of solid waste have increased by 1059 % for CH₄ and 228 % for N₂O since 1990, due to an increase in the number of biogas plants and the amount of biowaste composted in Denmark.

Wastewater handling contributes to the sectoral total in CO₂ equivalents in 2020 with 16.5 %. The CH₄ emissions from wastewater handling have increased by 28.7 % from 1990 to 2020 while the N₂O emission has decreased by 38.6 %.

Since all incinerated waste (municipal, industrial, hazardous) is used for power and heat production, the emissions are included in the 1A1a category.

2.4 Description and interpretation of emission trends for KP-LULUCF inventory in aggregate, by activity and by gas

Coverage relating to reporting of activities under Article 3.3 and selected activities under Article 3.4 are listed in Table 2.1 for reporting concerning change in carbon pool and for greenhouse gas sources. All pools are reported. Carbon stock change in below-ground biomass for Cropland Management and Grazing Land Management under Article 3.4 are included under Above-ground biomass for the same area categories. Fertilisation of forests and other land is negligible and all fertiliser consumption is therefore reported in the agricultural sector. All liming is reported under the agriculture sector. Field burning of wooden biomass is prohibited in Denmark and therefore reported as not occurring. Wildfires are very seldom and if occurring very small in Denmark.

Table 2.1 Coverage of reporting of change of carbon pools relating to activities under Article 3.3 and elected activities under Article 3.4.

Activity	CHANGE IN CARBON POOL REPORTED						
	Above-ground biomass	Below-ground biomass	Litter	Dead wood	Soil		HWP
					Mineral	Organic	
Article 3.3 activities							
Afforestation and reforestation	R	R	R	R	R	R	R
Deforestation	R	R	R	R	R	R	R
Article 3.4 activities							
Forest management	R	R	R	R	R	R	R
Cropland management	R	R	NO	NO	R	R	
Grazing land management	R	R	NO	NO	R	R	
Revegetation	NA	NA	NA	NA	NA	NA	
Wetland drainage and rewetting	NA	NA	NA	NA		NA	

Activity	GREENHOUSE GAS SOURCES REPORTED								
	Fertilization	Drained, rewetted and other soils		Nitrogen mineralization in mineral soils	Indirect N ₂ O emissions from managed soil	Biomass burning			
		N ₂ O	CH ₄			N ₂ O	N ₂ O	CO ₂	CH ₄
Article 3.3 activities									
Afforestation and reforestation	IE	R	R	NO	R	NO	NO	NO	
Deforestation	IE	R	R	R	IE	NO	NO	NO	
Article 3.4 activities									
Forest management	IE	R	R	NO	IE	NO	NO	NO	
Cropland management		R		IE		NO	NO	NO	
Grazing land management		R		IE		IE	R	R	
Revegetation	NA	NA	NA	NA	NA	NA	NA	NA	
Wetland drainage and rewetting	NA	NA	NA		NA	NA	NA	NA	

R: reported, NR: not reported, IE: included elsewhere, NO: not occurring, NA: not applicable. Biomass burning does not occur in all years and therefore sometimes reported as NO in the CRF.

CO₂ is by far the most important greenhouse gas relating to activities under Article 3.3 and Article 3.4. There is however a minor contribution of CH₄ and N₂O. Large fluctuations of emissions and removals occur for the LULUCF sector, partly due to annual climatic variations, e.g. temperature and wind, but also regulations and changes in the forestry are important parameters.

2.4.1 Forest

The trends in emissions and removals from forests are dependent on both the current structure of the forests and the management actions in the coming years. If similar management is applied as in the previous 15 years a decline in the total carbon stock in the forest is expected. However, for some years a sink in forest is reported. For the afforested areas a steady increase in carbon stocks is expected also in the future years. The rate of increase of area will depend on both availability of land and on possible subsidies for afforestation. Deforestation occurs mainly in relation to other specific projects e.g. for nature restoration or test areas for wind turbines.

2.4.2 Cropland and Grassland

The trend for the Cropland Management and Grazing Land Management under KP-LULUCF indicates that there has been a stabilisation of the loss of carbon from agricultural soils compared to previous due to an increased input of organic matter in the soil. However, the loss depends much of the climatic conditions. As a consequence of the global warming, where most years since 1990 have been above the average for 1961-1990, it is difficult to avoid substantial losses of carbon from the agricultural soils in the future. The changes in Cropland Management since 1990 have undoubtedly prevented further losses of soil carbon. A further increase in the actual temperature will affect the ability to prevent further losses of soil carbon.

3 Energy

3.1 Overview of the sector

The data presented in Chapter 3 relates to Denmark only, whereas information for Greenland is included in Chapter 16 and for the Faroe Islands in Annex 7.

The energy sector has been reported in four main chapters:

3.2 Stationary combustion plants (CRF sector 1A1, 1A2 and 1A4)

3.3 Transport and other mobile sources (CRF sector 1A2, 1A3, 1A4 and 1A5)

3.4 Additional information, fuel combustion (Reference approach, feedstocks and non-energy use of fuels)

3.5 Fugitive emissions (CRF sector 1B).

Summary tables for the energy sector are shown below.

Table 3.1.1 CO₂ emissions from the energy sector.

Greenhouse gas source categories	1990	1991	1992	1993	1994	1995	1996	1997	1998	1999
	kt									
1. Energy	51,672	62,200	56,365	58,659	62,617	59,411	72,665	63,142	59,086	56,508
1A. Fuel Combustion (Sectoral Approach)	51,331	61,550	55,688	58,077	62,042	58,957	72,167	62,445	58,563	55,402
1A1. Energy Industries	26,156	35,026	30,100	31,675	35,675	32,183	44,478	35,351	31,699	28,610
1A2. Manufacturing Industries and Construction	5,511	5,938	5,763	5,677	5,789	5,907	6,015	6,031	5,966	6,031
1A3. Transport	10,609	11,112	11,307	11,356	11,780	11,915	12,180	12,381	12,392	12,425
1A4. Other Sectors	8,888	9,137	8,323	9,074	8,484	8,634	9,249	8,437	8,224	8,071
1A5. Other	167	338	196	296	314	318	246	245	282	265
1B. Fugitive Emissions from Fuels	341	650	677	582	575	454	498	697	523	1,106
1B1. Solid Fuels	NO	NO	NO	NO	NO	NO	NO	NO	NO	NO
1B2. Oil and Natural Gas	341	650	677	582	575	454	498	697	523	1,106
1C. CO ₂ transport and storage	NO	NO	NO	NO	NO	NO	NO	NO	NO	NO
<i>Continued</i>	2000	2001	2002	2003	2004	2005	2006	2007	2008	2009
	kt									
1. Energy	52,152	53,815	53,429	58,659	53,066	49,492	57,453	52,671	49,478	47,577
1A. Fuel Combustion (Sectoral Approach)	51,429	53,044	52,755	57,990	52,314	48,944	56,922	52,128	49,091	47,315
1A1. Energy Industries	25,597	26,881	27,103	31,846	25,963	22,780	30,686	26,053	23,935	23,884
1A2. Manufacturing Industries and Construction	5,791	5,888	5,540	5,504	5,592	5,303	5,440	5,184	4,668	3,885
1A3. Transport	12,297	12,358	12,524	12,996	13,229	13,450	13,780	14,332	14,162	13,395
1A4. Other Sectors	7,546	7,729	7,403	7,453	7,187	7,038	6,788	6,282	6,118	5,891
1A5. Other	197	188	184	192	343	374	229	276	208	260
1B. Fugitive Emissions from Fuels	723	770	674	670	752	548	531	543	387	261
1B1. Solid Fuels	NO	NO	NO	NO	NO	NO	NO	NO	NO	NO
1B2. Oil and Natural Gas	723	770	674	670	752	548	531	543	387	261
1C. CO ₂ transport and storage	NO	NO	NO	NO	NO	NO	NO	NO	NO	NO
<i>Continued</i>	2010	2011	2012	2013	2014	2015	2016	2017	2018	2019
	kt									
1. Energy	48,017	42,871	38,475	40,315	36,110	33,807	35,397	33,032	32,999	29,336
1A. Fuel Combustion (Sectoral Approach)	47,664	42,619	38,258	40,071	35,860	33,560	35,124	32,790	32,767	29,141
1A1. Energy Industries	23,724	19,769	16,663	18,903	15,431	12,737	13,896	11,417	11,321	8,520
1A2. Manufacturing Industries and Construction	4,317	4,213	3,923	3,750	3,748	3,706	3,791	3,860	3,858	3,632
1A3. Transport	13,274	12,961	12,387	12,184	12,288	12,580	12,846	13,031	13,278	12,965
1A4. Other Sectors	6,143	5,384	5,071	4,996	4,163	4,341	4,385	4,180	4,094	3,826
1A5. Other	206	291	214	238	230	196	206	302	215	198
1B. Fugitive Emissions from Fuels	353	252	217	244	250	247	273	241	233	195
1B1. Solid Fuels	NO	NO	NO	NO	NO	NO	NO	NO	NO	NO
1B2. Oil and Natural Gas	353	252	217	244	250	247	273	241	233	195
1C. CO ₂ transport and storage	NO	NO	NO	NO	NO	NO	NO	NO	NO	NO
<i>Continued</i>	2020									
	kt									
1. Energy	26,481									
1A. Fuel Combustion (Sectoral Approach)	26,355									
1A1. Energy Industries	7,191									
1A2. Manufacturing Industries and Construction	3,500									
1A3. Transport	11,892									
1A4. Other Sectors	3,529									
1A5. Other	243									
1B. Fugitive Emissions from Fuels	126									
1B1. Solid Fuels	NO									
1B2. Oil and Natural Gas	126									
1C. CO ₂ transport and storage	NO									

Table 3.1.2 CH₄ emissions from the energy sector.

Greenhouse gas source categories	1990	1991	1992	1993	1994	1995	1996	1997	1998	1999
	kt									
1. Energy	15.78	18.81	19.55	21.65	24.94	30.68	35.25	36.47	37.23	39.66
1A. Fuel Combustion (Sectoral Approach)	10.47	11.50	12.09	14.17	17.20	22.91	26.98	26.50	27.71	27.31
1A1. Energy Industries	0.62	0.96	1.36	2.98	6.07	11.40	14.58	13.90	15.29	15.39
1A2. Manufacturing Industries and Construction	0.32	0.34	0.32	0.32	0.32	0.39	0.75	0.76	0.86	0.84
1A3. Transport	3.17	3.29	3.31	3.26	3.19	3.02	2.86	2.73	2.58	2.39
1A4. Other Sectors	6.27	6.82	7.02	7.52	7.53	7.99	8.69	9.01	8.88	8.59
1A5. Other	0.08	0.09	0.09	0.09	0.10	0.10	0.10	0.10	0.10	0.10
1B. Fugitive Emissions from Fuels	5.31	7.31	7.46	7.48	7.74	7.77	8.27	9.98	9.53	12.35
1B1. Solid Fuels	NO	NO	NO	NO	NO	NO	NO	NO	NO	NO
1B2. Oil and Natural Gas	5.31	7.31	7.46	7.48	7.74	7.77	8.27	9.98	9.53	12.35
<i>Continued</i>	2000	2001	2002	2003	2004	2005	2006	2007	2008	2009
	kt									
1. Energy	38.09	39.00	38.08	37.30	37.77	35.23	33.24	31.05	29.72	26.15
1A. Fuel Combustion (Sectoral Approach)	26.65	27.35	26.70	26.18	25.76	23.88	22.39	20.76	20.45	18.40
1A1. Energy Industries	14.68	15.56	15.13	14.39	14.07	12.43	11.51	9.59	10.10	8.82
1A2. Manufacturing Industries and Construction	1.05	1.11	1.01	0.98	0.99	0.85	0.69	0.48	0.53	0.49
1A3. Transport	2.20	2.04	1.91	1.80	1.66	1.50	1.37	1.23	1.04	0.89
1A4. Other Sectors	8.63	8.54	8.57	8.94	8.96	9.04	8.76	9.41	8.73	8.17
1A5. Other	0.09	0.09	0.08	0.08	0.08	0.07	0.06	0.05	0.04	0.03
1B. Fugitive Emissions from Fuels	11.44	11.65	11.38	11.11	12.00	11.35	10.85	10.29	9.27	7.75
1B1. Solid Fuels	NO	NO	NO	NO	NO	NO	NO	NO	NO	NO
1B2. Oil and Natural Gas	11.44	11.65	11.38	11.11	12.00	11.35	10.85	10.29	9.27	7.75
<i>Continued</i>	2010	2011	2012	2013	2014	2015	2016	2017	2018	2019
	kt									
1. Energy	28.14	23.83	19.35	17.87	15.50	14.82	14.99	14.63	14.17	13.25
1A. Fuel Combustion (Sectoral Approach)	20.60	17.56	13.83	12.62	10.43	10.10	10.47	10.28	10.39	10.16
1A1. Energy Industries	10.99	9.20	6.37	5.61	4.03	3.42	3.93	4.02	4.47	4.59
1A2. Manufacturing Industries and Construction	0.57	0.51	0.36	0.33	0.37	0.49	0.53	0.68	0.85	0.93
1A3. Transport	0.81	0.70	0.61	0.55	0.50	0.49	0.45	0.43	0.40	0.39
1A4. Other Sectors	8.21	7.13	6.48	6.12	5.52	5.69	5.56	5.14	4.66	4.24
1A5. Other	0.03	0.02	0.02	0.01	0.01	0.01	0.01	0.01	0.01	0.01
1B. Fugitive Emissions from Fuels	7.55	6.26	5.52	5.25	5.07	4.72	4.51	4.36	3.78	3.10
1B1. Solid Fuels	NO	NO	NO	NO	NO	NO	NO	NO	NO	NO
1B2. Oil and Natural Gas	7.55	6.26	5.52	5.25	5.07	4.72	4.51	4.36	3.78	3.10
<i>Continued</i>	2020									
	kt									
1. Energy	10.70									
1A. Fuel Combustion (Sectoral Approach)	8.57									
1A1. Energy Industries	3.37									
1A2. Manufacturing Industries and Construction	0.91									
1A3. Transport	0.35									
1A4. Other Sectors	3.94									
1A5. Other	0.01									
1B. Fugitive Emissions from Fuels	2.13									
1B1. Solid Fuels	NO									
1B2. Oil and Natural Gas	2.13									

Table 3.1.3 N₂O emissions from the energy sector.

Greenhouse gas source categories	1990	1991	1992	1993	1994	1995	1996	1997	1998	1999
	kt									
1. Energy	1.21	1.51	1.49	1.47	1.51	1.48	1.65	1.70	1.56	1.88
1A. Fuel Combustion (Sectoral Approach)	1.03	1.15	1.12	1.15	1.19	1.24	1.38	1.31	1.28	1.26
1A1. Energy Industries	0.29	0.37	0.34	0.36	0.39	0.38	0.51	0.44	0.42	0.40
1A2. Manufacturing Industries and Construction	0.21	0.22	0.22	0.20	0.20	0.25	0.25	0.25	0.25	0.25
1A3. Transport	0.33	0.35	0.36	0.37	0.38	0.39	0.40	0.40	0.40	0.39
1A4. Other Sectors	0.20	0.21	0.21	0.22	0.21	0.21	0.22	0.21	0.20	0.21
1A5. Other	0.00	0.01	0.01	0.01	0.01	0.01	0.01	0.01	0.01	0.01
1B. Fugitive Emissions from Fuels	0.18	0.36	0.37	0.32	0.31	0.24	0.27	0.39	0.28	0.62
1B1. Solid Fuels	NO	NO	NO	NO	NO	NO	NO	NO	NO	NO
1B2. Oil and Natural Gas	0.18	0.36	0.37	0.32	0.31	0.24	0.27	0.39	0.28	0.62
<i>Continued</i>	2000	2001	2002	2003	2004	2005	2006	2007	2008	2009
	kt									
1. Energy	1.63	1.68	1.60	1.66	1.65	1.50	1.58	1.57	1.46	1.35
1A. Fuel Combustion (Sectoral Approach)	1.23	1.25	1.23	1.28	1.23	1.20	1.29	1.27	1.25	1.21
1A1. Energy Industries	0.38	0.40	0.40	0.44	0.39	0.36	0.42	0.36	0.35	0.36
1A2. Manufacturing Industries and Construction	0.24	0.24	0.22	0.21	0.22	0.21	0.22	0.23	0.22	0.18
1A3. Transport	0.39	0.38	0.38	0.38	0.38	0.37	0.37	0.38	0.39	0.38
1A4. Other Sectors	0.21	0.22	0.22	0.24	0.24	0.26	0.27	0.29	0.29	0.28
1A5. Other	0.01	0.00	0.01	0.01	0.01	0.01	0.01	0.01	0.01	0.01
1B. Fugitive Emissions from Fuels	0.40	0.43	0.37	0.37	0.42	0.30	0.29	0.29	0.21	0.14
1B1. Solid Fuels	NO	NO	NO	NO	NO	NO	NO	NO	NO	NO
1B2. Oil and Natural Gas	0.40	0.43	0.37	0.37	0.42	0.30	0.29	0.29	0.21	0.14
<i>Continued</i>	2010	2011	2012	2013	2014	2015	2016	2017	2018	2019
	kt									
1. Energy	1.46	1.35	1.28	1.33	1.28	1.32	1.40	1.38	1.38	1.29
1A. Fuel Combustion (Sectoral Approach)	1.27	1.22	1.17	1.19	1.15	1.18	1.25	1.24	1.25	1.18
1A1. Energy Industries	0.38	0.33	0.31	0.33	0.29	0.28	0.30	0.29	0.29	0.27
1A2. Manufacturing Industries and Construction	0.20	0.20	0.18	0.17	0.15	0.16	0.19	0.19	0.20	0.18
1A3. Transport	0.39	0.41	0.41	0.42	0.44	0.45	0.47	0.47	0.48	0.47
1A4. Other Sectors	0.30	0.27	0.26	0.27	0.25	0.28	0.29	0.28	0.27	0.26
1A5. Other	0.01	0.01	0.01	0.01	0.01	0.01	0.01	0.01	0.01	0.01
1B. Fugitive Emissions from Fuels	0.19	0.12	0.11	0.14	0.14	0.14	0.16	0.15	0.14	0.11
1B1. Solid Fuels	NO	NO	NO	NO	NO	NO	NO	NO	NO	NO
1B2. Oil and Natural Gas	0.19	0.12	0.11	0.14	0.14	0.14	0.16	0.15	0.14	0.11
<i>Continued</i>	2020									
	kt									
1. Energy	1.20									
1A. Fuel Combustion (Sectoral Approach)	1.13									
1A1. Energy Industries	0.25									
1A2. Manufacturing Industries and Construction	0.18									
1A3. Transport	0.44									
1A4. Other Sectors	0.24									
1A5. Other	0.01									
1B. Fugitive Emissions from Fuels	0.07									
1B1. Solid Fuels	NO									
1B2. Oil and Natural Gas	0.07									

Table 3.1.4 Emissions of NO_x, CO, NMVOC and SO₂ from the energy sector in 2020.

	NO _x , kt	CO, kt	NMVOC, kt	SO ₂ , kt
1. Energy	68.85	184.11	26.57	7.14
A. Fuel Combustion (Sectoral Approach)	68.78	183.99	19.50	6.36
1. Energy Industries	13.69	13.91	0.86	2.12
2. Manufacturing Industries and Construction	7.40	12.28	1.12	2.63
3. Transport	33.30	52.74	5.92	0.31
4. Other Sectors	13.16	102.03	11.32	1.22
5. Other	1.24	3.02	0.27	0.08
B. Fugitive Emissions from Fuels	0.07	0.12	7.07	0.77
1. Solid Fuels	NO	NO	NO	NO
2. Oil and Natural Gas	0.07	0.12	7.07	0.77

3.2 Stationary combustion

Stationary combustion is the largest source of CO₂ emission in Denmark accounting for 44 % of the 2020 national total CO₂ emissions excl. LULUCF or 40 % of the CO₂ emission including LULUCF. The CO₂ emission from stationary combustion has decreased by 68 % since 1990. The decreased emission since 1990 is a result of both at decreased fuel consumption and a change of fuel types applied; the consumption of coal has decreased whereas the consumption of biomass has increased since 1990. The relatively large fluctuations in the CO₂ emission time series from 1990 to 2020 are due to inter-country electricity trade fluctuations caused mainly by variation in hydropower generation in Norway and Sweden. The CO₂ emission in 2020 was 12 % lower than in 2019.

The methane (CH₄) emission from stationary combustion plants accounted for 2.8 % of the national CH₄ emission in 2020. The CH₄ emission from stationary combustion has increased by 18 % since 1990. The emission increased until 1996 and decreased after 2004. The trend is related to the considerable number of lean-burn gas engines installed in CHP plants in Denmark during the 1990s. The CH₄ emission from gas engines is high compared to other plant types. The deregulation of the electricity market has made production of electricity in gas engines less favourable, therefore the fuel consumption and CH₄ emission has decreased since 2004. The CH₄ emission in 2020 was 16 % lower than in 2019.

The nitrous oxide (N₂O) emission from stationary combustion plants accounted for 3.1 % of the national N₂O emission in 2020. The N₂O emission from stationary combustion was 3 % lower than in 1990, but as for CO₂, fluctuations in emission level due to electricity import/export are considerable. The emission in 2020 was 4 % lower than in 2019.

3.2.1 Source category description

Source category definition

Stationary combustion plants are included in the emission source subcategories:

- 1A1 Energy, Fuel combustion, Energy Industries
 - 1A1a Public electricity and heat production
 - 1A1b Petroleum refining
 - 1A1c Oil and gas extraction

- 1A2 Energy, Fuel combustion, Manufacturing Industries and Construction
 - 1A2a Iron and steel
 - 1A2b Non-ferrous metals
 - 1A2c Chemicals
 - 1A2d Pulp, Paper and Print
 - 1A2e Food processing, beverages and tobacco
 - 1A2f Non-metallic minerals
 - 1A2 g viii Other manufacturing industry
- 1A4 Energy, Fuel combustion, Other Sectors
 - 1A4a i Commercial/institutional plants.
 - 1A4b i Residential plants.
 - 1A1c i Agriculture/forestry.

The emission and fuel consumption data included in tables and figures in Chapter 3.2 only include emissions originating from stationary combustion plants of a given CRF sector. The consumption of fuel for military use in stationary combustion plants has been included in commercial/institutional plants.

In the Danish emission database, all activity rates and emissions are defined in SNAP sector categories (Selected Nomenclature for Air Pollution) according to the CORINAIR system. The emission inventories are prepared from a complete emission database based on the SNAP source categories. Danish Centre for Environment and Energy, Aarhus University (DCE) has modified the SNAP categorisation to enable direct reporting of the disaggregated data for manufacturing industries and construction. Aggregation to the IPCC source category codes is based on a correspondence list enclosed in Annex 3A-1. Stationary combustion is defined as combustion activities in the SNAP sectors 01 – 03, not including SNAP 0303.

The CO₂ emission from calcinations is not part of the source category Energy. This emission is included in the source category Industrial Processes.

3.2.1 Methodology overview, tier

The type of emission factor and the applied tier level for each emission source are shown in Table 3.2.1 below. The tier level has been determined based on the IPCC Guidelines (IPCC, 2006).

The fuel consumption data for transformation are technology specific. For end-use of fuels, the disaggregation to specific technologies is less detailed. However, for residential wood combustion the technology disaggregation is technology specific.

The distinction between tier 2 and 3 has been based on the emission factor. The tier level definitions have been interpreted as follows:

- Tier 1: The emission factor is an IPCC default tier 1 value.
- Tier 2: The emission factors are country-specific and based on a limited number of emission measurements or a technology specific IPCC tier 2 emission factor.
- Tier 3: Emission data are based on:
 - Plant specific emission measurements or

- Technology specific fuel consumption data and country-specific emission factors based on a considerable number of emission measurements from Danish plants.

Table 3.2.1 gives an overview of the calculation methods and type of emission factor. The table also shows which of the source categories are key in any of the key category analysis¹ (including LULUCF, approach 1/approach 2, level/trend).

This year, two source categories based on tier 1 approach have been identified as key sources. The total emission from these emission sources adds up to 39 kton CO₂ equivalent or 0.09 % of the national total in 2020. In 1990, the emission from the two emission sources adds up to 378 kton or 0.5 % of national total. Additional information is included in Chapter 3.2.5.

¹ Key category according to the KCA approach 1 or approach 2 for Denmark (excluding Greenland and Faroe Islands), including LULUCF, level 1990/level 2020/trend.

Table 3.2.1 Methodology and type of emission factor.

		Tier	EMF ¹⁾	Key category ²⁾
1A Stationary combustion, Coal, ETS data	CO ₂	Tier 3	PS	Yes
1A Stationary combustion, Coal, no ETS data	CO ₂	Tier 3 ³⁾	CS	Yes
1A Stationary combustion, BKB	CO ₂	Tier 1	D	No
1A Stationary combustion, Coke oven coke	CO ₂	Tier 1/Tier 3	D/PS	No
1A Stationary combustion, Fossil waste, ETS data	CO ₂	Tier 3	PS	Yes
1A Stationary combustion, Fossil waste, no ETS data	CO ₂	Tier 2	CS	Yes
1A Stationary combustion, Petroleum coke, ETS data	CO ₂	Tier 3	PS	Yes
1A Stationary combustion, Petroleum coke, no ETS data	CO ₂	Tier 2	CS	Yes
1A Stationary combustion, Residual oil, ETS data	CO ₂	Tier 3	PS	Yes
1A Stationary combustion, Residual oil, no ETS data	CO ₂	Tier 2 ⁴⁾	CS	Yes
1A Stationary combustion, Gas oil	CO ₂	Tier 2/Tier 3 ⁵⁾	CS / PS	Yes
1A Stationary combustion, Kerosene	CO ₂	Tier 1	D	Yes
1A Stationary combustion, LPG	CO ₂	Tier 2/Tier 3 ⁶⁾	CS / PS	Yes
1A1b Stationary combustion, Petroleum refining, Refinery gas	CO ₂	Tier 3	CS	Yes
1A Stationary combustion, Natural gas, onshore	CO ₂	Tier 3	CS	Yes
1A1c_ii Stationary combustion, Oil and gas extraction, Offshore gas turbines, Natural gas	CO ₂	Tier 3	CS	Yes
1A1 Stationary Combustion, solid fuels	CH ₄	Tier 2	D(2)	No
1A1 Stationary Combustion, liquid fuels	CH ₄	Tier/Tier 2	D / D(2) / CS	No
1A1 Stationary Combustion, not engines, gaseous fuels	CH ₄	Tier 2	CS / D(2)	No
1A1 Stationary Combustion, waste	CH ₄	Tier 2	CS	No
1A1 Stationary Combustion, not engines, biomass	CH ₄	Tier 3/Tier 2/Tier 1	CS / D(2) / D	No
1A2 Stationary Combustion, solid fuels	CH ₄	Tier 1	D	No
1A2 Stationary Combustion, liquid fuels	CH ₄	Tier 1/Tier 2	D / D(2) / CS	No
1A2 Stationary Combustion, not engines, gaseous fuels	CH ₄	Tier 2	CS / D(2)	No
1A2 Stationary Combustion, waste	CH ₄	Tier 1	D	No
1A2 Stationary Combustion, not engines, biomass	CH ₄	Tier 2/Tier 1	D(2) / D	No
1A4 Stationary Combustion, solid fuels	CH ₄	Tier 1	D	No
1A4 Stationary Combustion, liquid fuels	CH ₄	Tier 1/Tier 2	D / D(2)	No
1A4 Stationary Combustion, not engines, gaseous fuels	CH ₄	Tier 2	D(2)	No
1A4 Stationary Combustion, waste	CH ₄	Tier 1	D	No
1A4 Stationary Combustion, not engines, not residential wood and not residential/agricultural straw, biomass	CH ₄	Tier 1/Tier 2	D / D(2) / CS	No
1A4b_i Stationary combustion, Residential wood combustion	CH ₄	Tier 2	CS	No
1A4b_i/1A4c_i Stationary Combustion, Residential and agricultural straw combustion	CH ₄	Tier 1	D	No
1A Stationary combustion, Natural gas fuelled engines, gaseous fuels	CH ₄	Tier 3	CS	No
1A Stationary combustion, Biogas fuelled engines, biomass	CH ₄	Tier 3	CS	No
1A1 Stationary Combustion, solid fuels	N ₂ O	Tier 2	CS / D(2)	Yes
1A1 Stationary Combustion, liquid fuels	N ₂ O	Tier 2/Tier 1	D(2) / CS / D	No
1A1 Stationary Combustion, gaseous fuels	N ₂ O	Tier 3/Tier 2	CS / D(2)	No
1A1 Stationary Combustion, waste	N ₂ O	Tier 2	CS	Yes
1A1 Stationary Combustion, biomass	N ₂ O	Tier 2/Tier 1	CS / D(2) / D	Yes
1A2 Stationary Combustion, solid fuels	N ₂ O	Tier 1/Tier 3	D/PS	Yes
1A2 Stationary Combustion, liquid fuels	N ₂ O	Tier 2/Tier 1	D(2) / CS / D	Yes
1A2 Stationary Combustion, gaseous fuels	N ₂ O	Tier 3/Tier 2	CS / D(2)	No
1A2 Stationary Combustion, waste	N ₂ O	Tier 1	D	No
1A2 Stationary Combustion, biomass	N ₂ O	Tier 1/Tier 2	D / CS	No
1A4 Stationary Combustion, solid fuels	N ₂ O	Tier 1	D	No
1A4 Stationary Combustion, liquid fuels	N ₂ O	Tier 2/Tier 1	D(2) / CS / D	Yes
1A4 Stationary Combustion, gaseous fuels	N ₂ O	Tier 3/Tier 2	CS / D(2)	No
1A4 Stationary Combustion, waste	N ₂ O	Tier 1	D	No
1A4 Stationary Combustion, not residential wood and not residential/agricultural straw, biomass	N ₂ O	Tier 1/Tier 2	D / CS	No
1A4b_i Stationary Combustion, Residential wood combustion	N ₂ O	Tier 1	D	Yes
1A4b_i/1A4c_i Stationary Combustion, Residential and agricultural straw combustion	N ₂ O	Tier 1	D	No

1) D: IPCC (2006) default, tier 1. D(2): IPCC (2006) default, tier 2. CS: Country specific. PS: Plant specific. 2) KCA approach 1 or approach 2 for Denmark (excluding Greenland and Faroe Islands), including LULUCF, level 1990 or level 2020 or trend 1990-2020. 3) Only 5 % of the total coal consumption is included in the non-ETS category in 2020. 4) Only 7 % of the total residual oil consumption is included in the non-ETS category in 2020. 5) Tier 3 for less than 1 % of the gas oil consumption in 2020. 6) Tier 3 for less than 1 % of the LPG consumption in 2020.

Key Categories

Key Category Analysis (KCA) approach 1 and approach 2 for the years 1990 and 2020 and for the trend 1990-2020 for Denmark has been carried out in accordance with the IPCC Guidelines (IPCC, 2006). Table 3.2.2 shows the 21

stationary combustion key categories. The table is based on the analysis including LULUCF. Detailed key category analysis is shown in NIR Chapter 1.5 and Annex 1.

The CO₂ emissions from stationary combustion are key categories for all the major fuels. This year, CH₄ from stationary combustion is not among the key categories. Due to the relatively high uncertainty for N₂O, emission factors the N₂O emission from several emission sources are key categories in the approach 2 analysis.

Table 3.2.2 Key categories², stationary combustion.

		Approach 1			Approach 2		
		1990	2020	1990-2020	1990	2020	1990-2020
1A Stationary combustion, Coal, ETS data, CO ₂	CO ₂		Level	Trend			
1A Stationary combustion, Coal, no ETS data, CO ₂	CO ₂	Level	Level	Trend	Level		Trend
1A Stationary combustion, Fossil waste, ETS data, CO ₂	CO ₂		Level	Trend			Trend
1A Stationary combustion, Fossil waste, no ETS data, CO ₂	CO ₂	Level	Level	Trend			
1A Stationary combustion, Petroleum coke, ETS data, CO ₂	CO ₂		Level	Trend			
1A Stationary combustion, Petroleum coke, no ETS data, CO ₂	CO ₂	Level		Trend			
1A Stationary combustion, Residual oil, ETS data, CO ₂	CO ₂		Level	Trend			
1A Stationary combustion, Residual oil, no ETS data, CO ₂	CO ₂	Level		Trend			
1A Stationary combustion, Gas oil, CO ₂	CO ₂	Level	Level	Trend	Level		Trend
1A Stationary combustion, Kerosene, CO ₂	CO ₂	Level		Trend			
1A Stationary combustion, LPG, CO ₂	CO ₂		Level				
1A1b Stationary combustion, Petroleum refining, Refinery gas, CO ₂	CO ₂	Level	Level	Trend			
1A Stationary combustion, Natural gas, onshore, CO ₂	CO ₂	Level	Level	Trend			
1A1c_ii Stationary combustion, Oil and gas extraction, Offshore gas turbines, Natural gas, CO ₂	CO ₂	Level	Level	Trend			
1A1 Stationary Combustion, Solid fuels, N ₂ O	N ₂ O				Level		Trend
1A1 Stationary Combustion, Waste, N ₂ O	N ₂ O						Trend
1A1 Stationary Combustion, Biomass, N ₂ O	N ₂ O				Level		Trend
1A2 Stationary Combustion, Solid fuels, N ₂ O	N ₂ O				Level		Trend
1A2 Stationary Combustion, Liquid fuels, N ₂ O	N ₂ O				Level		Trend
1A4 Stationary Combustion, Liquid fuels, N ₂ O	N ₂ O						Trend
1A4b_i Stationary Combustion, Residential wood combustion, N ₂ O	N ₂ O				Level		Trend

3.2.2 Fuel consumption data

In 2020, the total fuel consumption for stationary combustion plants was 342 PJ of which 175 PJ was fossil fuels and 168 PJ was biomass. Fuel consumption distributed according to the stationary combustion subcategories is shown in Figure 3.2.1 and Figure 3.2.2. The fuel consumption in Public electricity and heat production adds up to 51 % of the fuel consumption in stationary combustion plants. Other source categories with high fuel consumption are Residential and Industry.

² For Denmark, not including Greenland & Faroe Island. Based on the KCA including LULUCF.

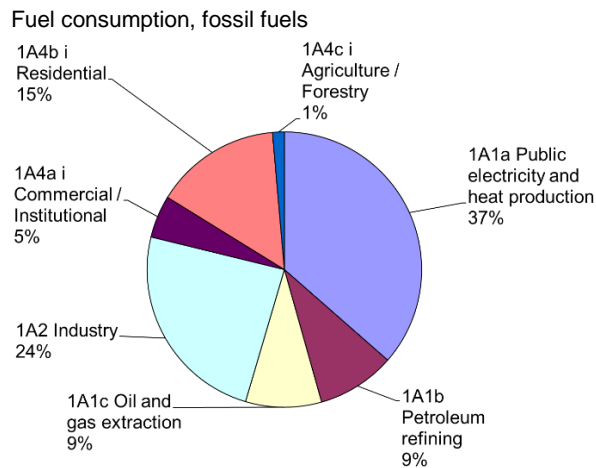
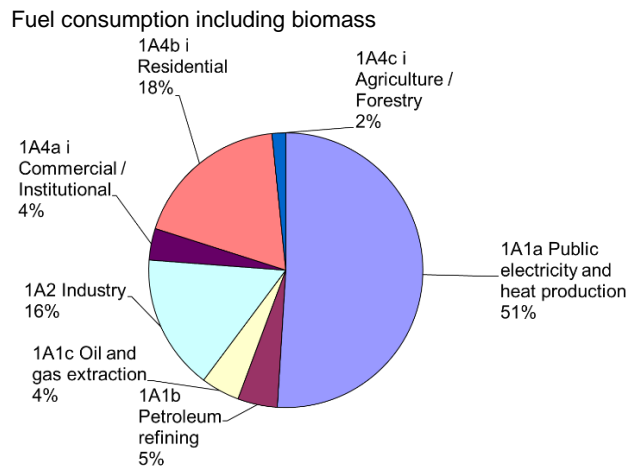

Figure 3.2.1 Fuel consumption of stationary combustion source categories, 2020. Based on DEA (2021a).

Wood/wood pellets, natural gas, waste, and coal are the most utilised fuels for stationary combustion plants. Natural gas is used in power plants and in decentralised combined heating and power (CHP) plants, as well as in industry, residential plants and offshore gas turbines (see Figure 3.2.2). Wood is mainly applied for public electricity and heat production and in residential plants. Coal is mainly used in power plants.

Detailed fuel consumption rates are shown in Annex 3A-2.

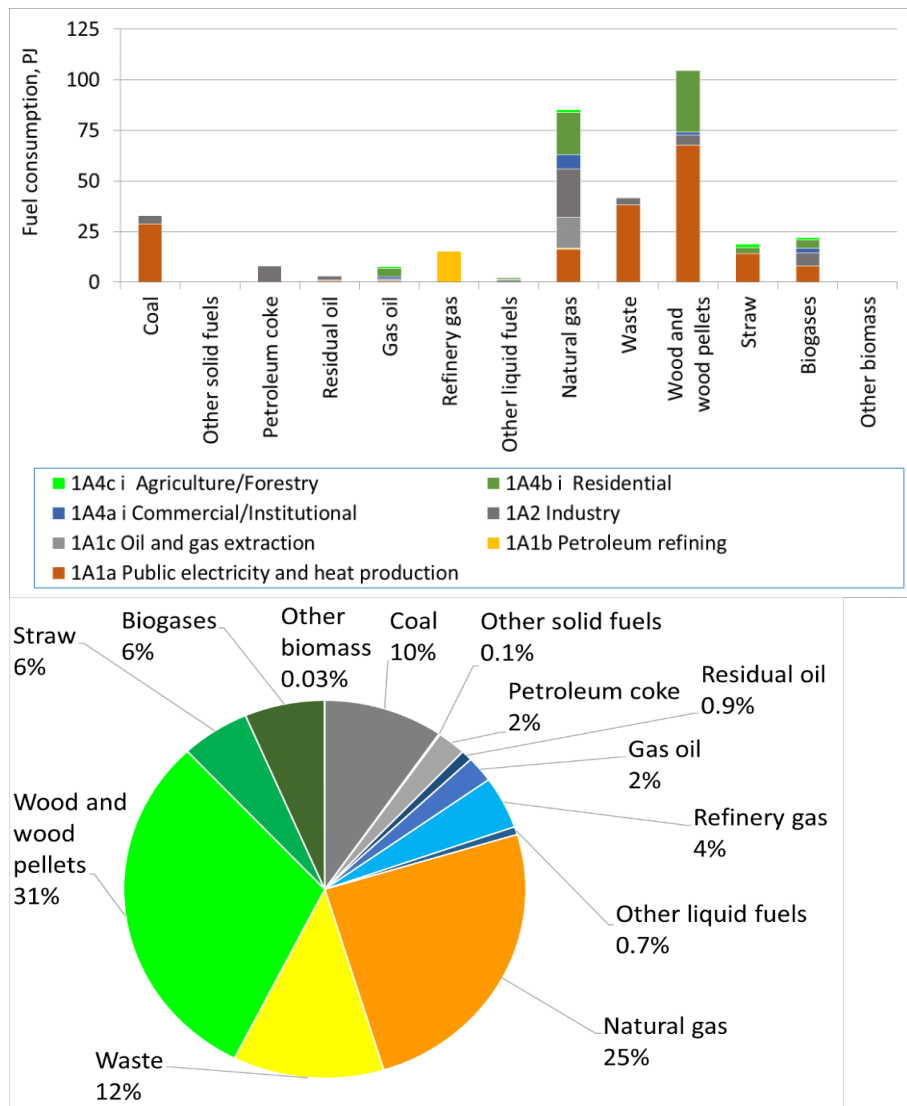

Figure 3.2.2 Fuel consumption of stationary combustion 2020, disaggregated to fuel type. Based on DEA (2021a).

Time series for fuel consumption for stationary combustion plants are presented in Figure 3.2.3. The fuel consumption for stationary combustion was 33 % lower in 2020 than in 1990, while the fossil fuel consumption was 63 % lower and the biomass fuel consumption 4.1 times the level in 1990.

The consumption of waste and biomass has increased since 1990 whereas the consumption of coal and oil has decreased.

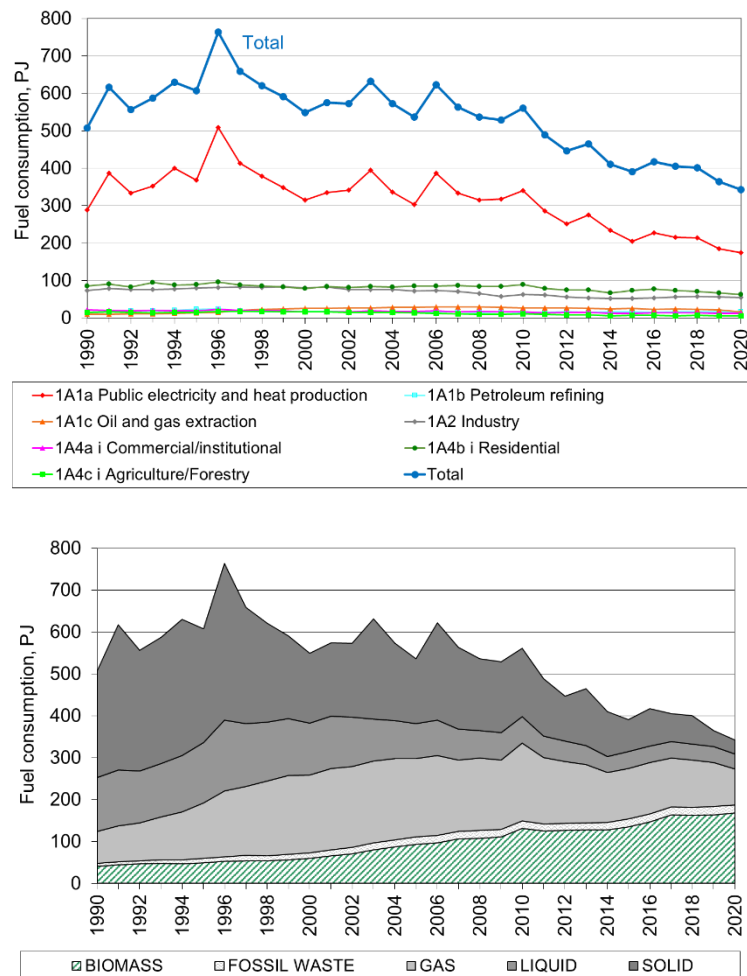

Figure 3.2.3 Fuel consumption time series, stationary combustion. Based on DEA (2021a).

The fluctuations in the time series for fuel consumption are mainly a result of electricity import/export, but also of outdoor temperature variations from year to year. This, in turn, leads to fluctuations in emission levels. The fluctuations in electricity trade, fuel consumption, CO₂ and NO_x emission are illustrated and compared in Figure 3.2.4. In 1990, the Danish net electricity import was large causing relatively low fuel consumption, whereas the fuel consumption was high in 1996, 2003 and 2006 due to a large net electricity export. In 2020, the net electricity import was 25 PJ, whereas there was a 21 PJ net electricity import in 2019. The large net electricity export that occurs some years is a result of low rainfall in Norway and Sweden causing insufficient hydropower production in both countries.

The Danish electricity production is highly dependent on the electricity trade with especially Sweden and Norway. Denmark has a number of central coal-fuelled power plants that consists of a number of blocks. These do not under normal conditions, operate at max load, i.e. there is free capacity for peak situations. In addition, there are blocks, which are mothballed but can be reopened in situations where there is a significant increase in the electricity demand.

To be able to follow the national energy consumption, the Danish Energy Agency (DEA) produces a correction of the observed fuel consumption and CO₂ emission without random variations in electricity import/export and in ambient temperature. This fuel consumption trend is also illustrated in Figure

3.2.4. The estimates are based on DEA (2016) and updated data (DEA, 2021d). The corrections are included here to explain the fluctuations in the time series for fuel rates and emissions.

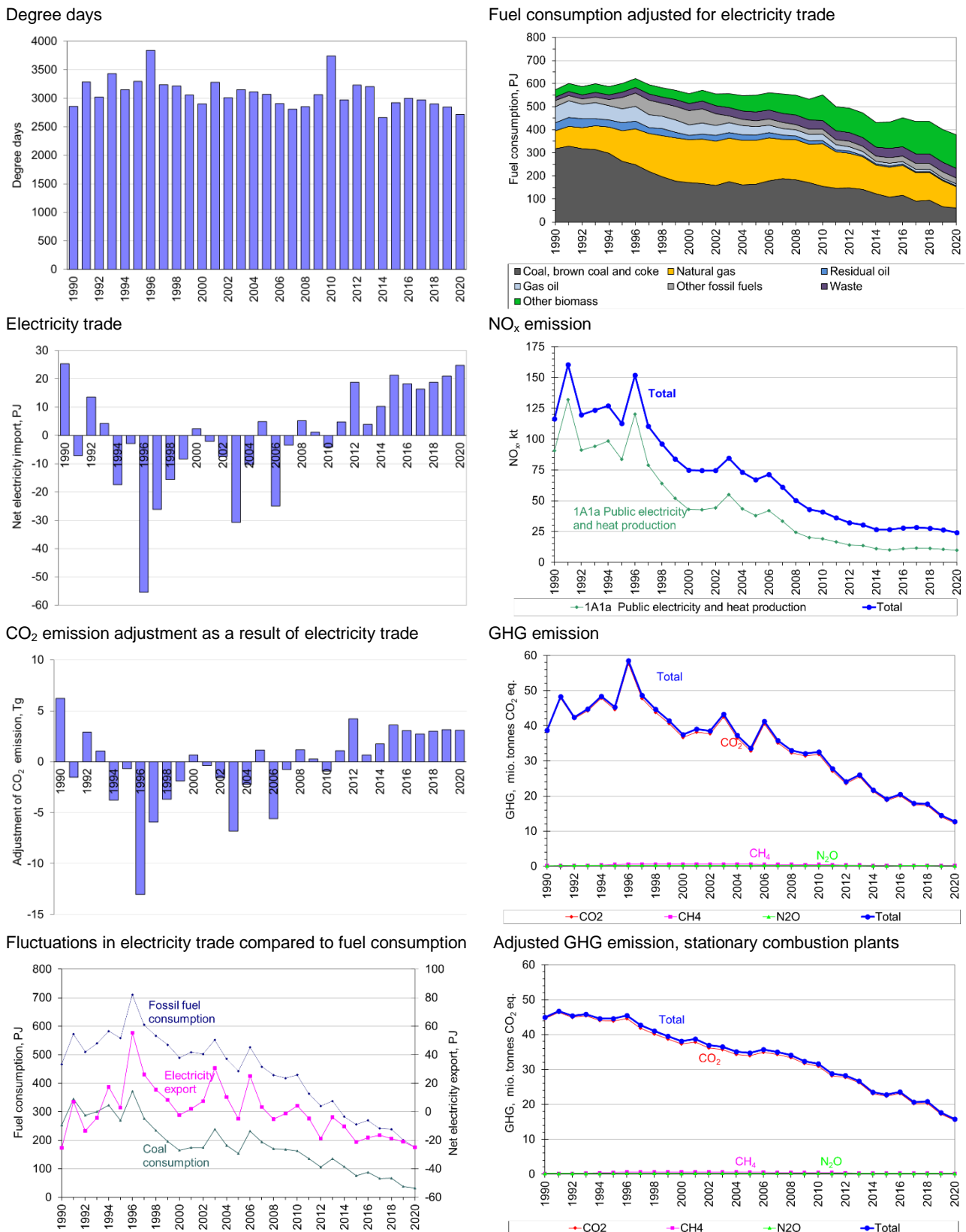

Figure 3.2.4 Comparison of time series fluctuations for net electricity import, fuel consumption, CO₂ emission and NO_x emission. Based on DEA (2021a).

Time series for fuel consumption for the subcategories to stationary combustion are shown in Figure 3.2.5, 3.2.6 and 3.2.7.

Fuel consumption for Energy industries fluctuates due to electricity trade as discussed above. The fuel consumption in 2020 was 34 % lower than in 1990 and the fossil fuel consumption was 68 % lower. The fluctuation in electricity production is based on fossil fuel consumption in the subcategory Public electricity and heat production. The energy consumption in Oil and gas extraction is mainly natural gas used in gas turbines in the offshore industry. The biomass fuel consumption in Energy industries in 2020 added up to 111 PJ, which is 6.8 times the level in 1990 and 3 % higher than in 2019.

The fuel consumption in Industry was 25 % lower in 2020 than in 1990 (Figure 3.2.6) and the fossil fuel consumption was 37 % lower. The fuel consumption in industrial plants decreased considerably after 2006 as a result of the financial crisis. The biomass fuel consumption in Industry in 2020 added up to 12 PJ, which is 2.0 times the consumption in 1990.

The fuel consumption in Other Sectors decreased 33 % since 1990 (Figure 3.2.7) and decreased 5 % since 2019. The fossil fuel consumption decreased 64 % since 1990. The biomass fuel consumption in Other sectors in 2020 added up to 45 PJ, which is 2.4 times the consumption in 1990. The consumption of wood and wood pellets in residential plants in 2020 was 2.1 times the consumption in year 2000 and 3.4 times the consumption in 1990.

Time series for subcategories are shown in Chapter 3.2.4.

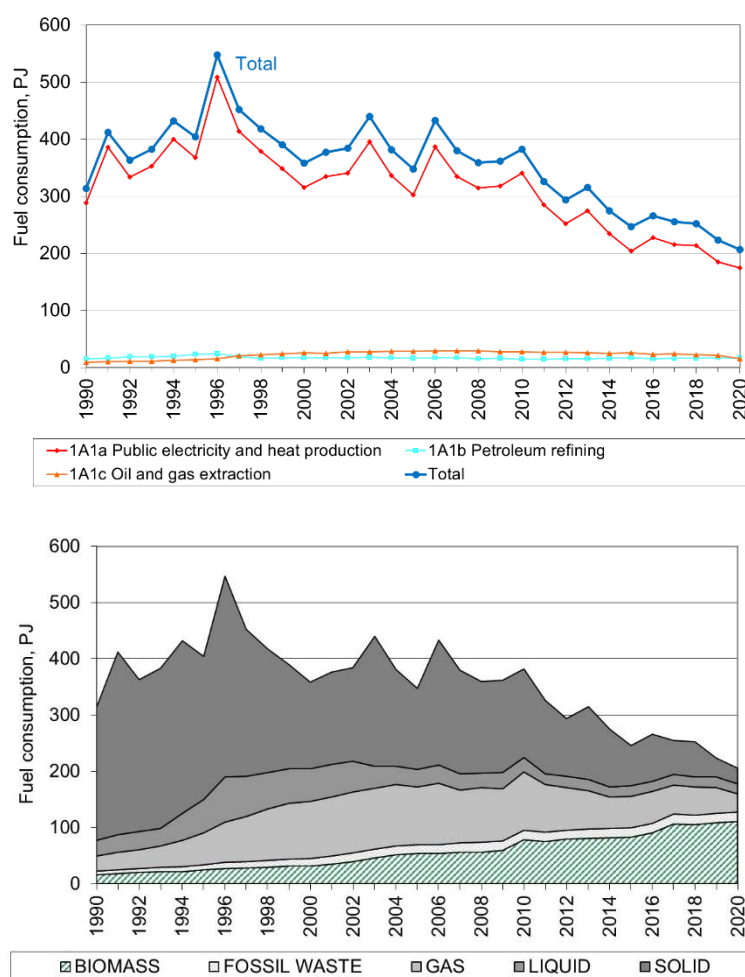

Figure 3.2.5 Fuel consumption time series for subcategories - 1A1 Energy Industries.

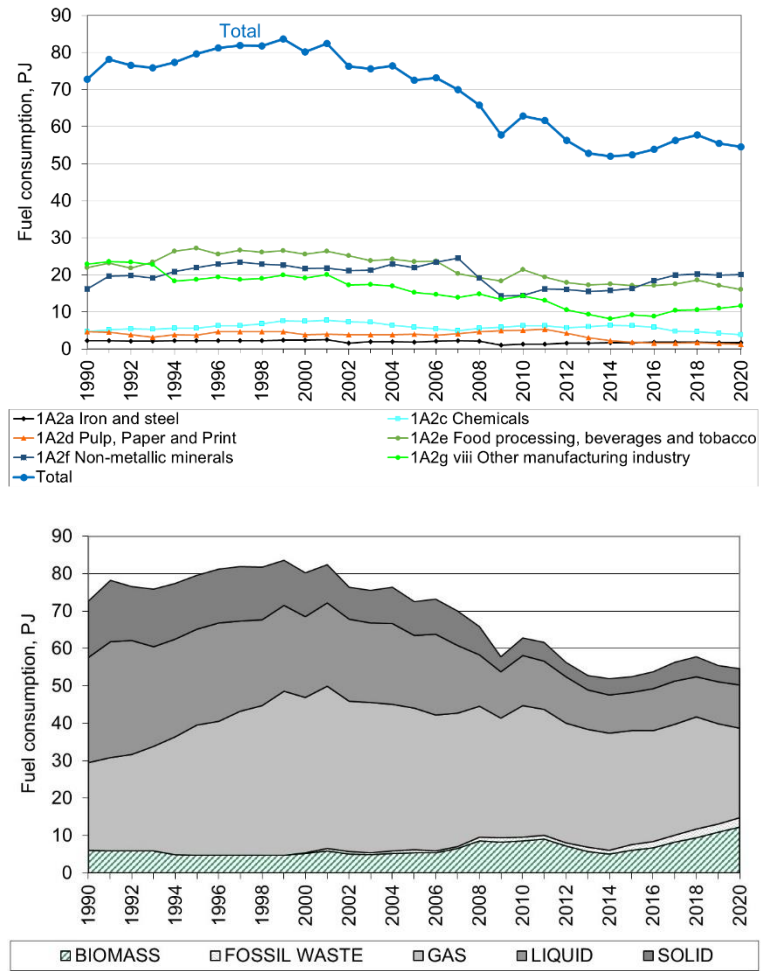

Figure 3.2.6 Fuel consumption time series for subcategories - 1A2 Industry.

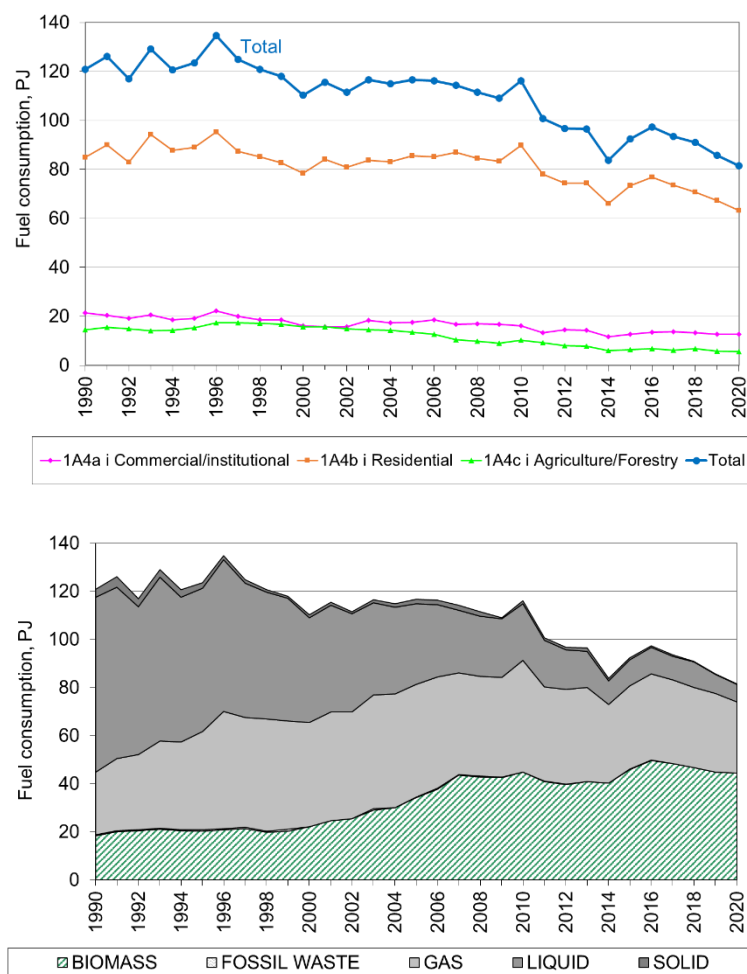

Figure 3.2.7 Fuel consumption time series for subcategories - 1A4 Other Sources.

3.2.3 Emissions

Greenhouse gas emission

The greenhouse gas emissions from stationary combustion are listed in Table 3.2.3. The emission from stationary combustion accounted for 28.5 % of the national greenhouse gas emission (including LULUCF) in 2020.

The CO₂ emission from stationary combustion plants accounts for 40 % of the national CO₂ emission (including LULUCF). The CH₄ emission accounts for 2.8 % of the national CH₄ emission and the N₂O emission for 3.1 % of the national N₂O emission.

Table 3.2.3 Greenhouse gas emission, 2020 ¹⁾.

	CO ₂	CH ₄	N ₂ O
	kt CO ₂ equivalent		
1A1 Fuel Combustion, Energy industries	7191	84	76
1A2 Fuel Combustion, Manufacturing Industries and Construction ¹⁾	2957	22	47
1A4 Fuel Combustion, Other sectors ¹⁾	2185	96	56
Emission from stationary combustion plants	12333	202	179
Emission share for stationary combustion (LULUCF included)	40%	2.8%	3.1%

¹⁾ Only stationary combustion sources of the category are included.

CO₂ is the most important greenhouse gas for stationary combustion accounting for 97.0 % of the greenhouse gas emission (CO₂ equivalents) from stationary combustion. CH₄ accounts for 1.6 % and N₂O for 1.4 % of the greenhouse gas emission (CO₂ equivalents) from stationary combustion (Figure 3.2.8).

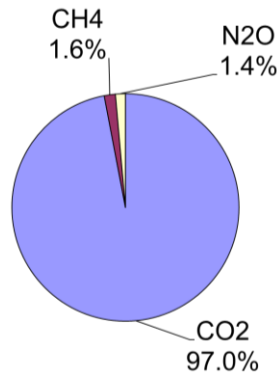

Figure 3.2.8 Greenhouse gas emission from stationary combustion (CO₂ equivalents), contribution from each pollutant.

Figure 3.2.9 shows the time series of greenhouse gas emissions (CO₂ equivalents) from stationary combustion. The development of the greenhouse gas emission follows the CO₂ emission development very closely. Both the CO₂ and the total greenhouse gas emission are lower in 2020 than in 1990, CO₂ is 67.9 % lower and greenhouse gas emissions are 67.2 % lower. However, fluctuations in the GHG emission level are large.

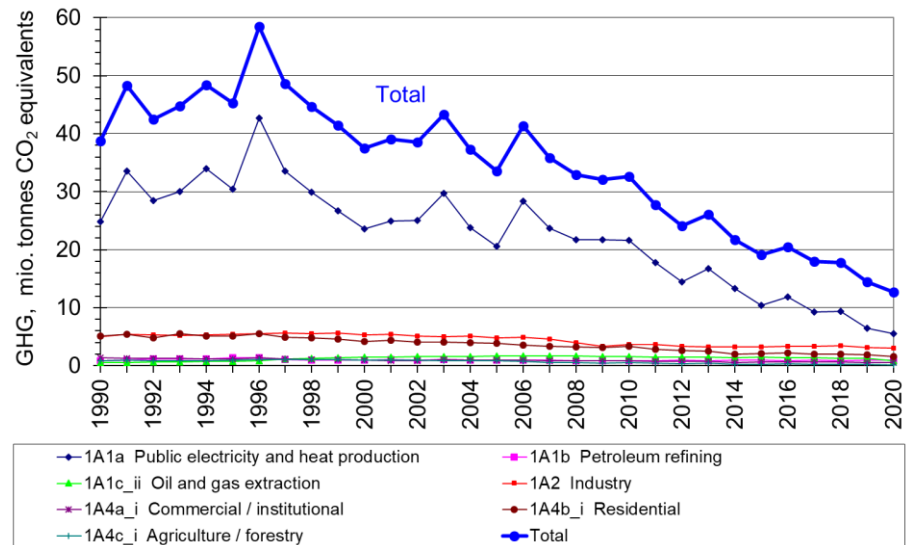

Figure 3.2.9 GHG emission time series for stationary combustion.

The fluctuations in the time series are largely a result of electricity import/export, but also of outdoor temperature variations from year to year. The fluctuations follow the fluctuations in fuel consumption discussed in Chapter 3.2.2. As mentioned in Chapter 3.2.2, the Danish Energy Agency estimates a correction of the observed CO₂ emission without random variations in electricity imports/exports and in ambient temperature. The greenhouse gas emission corrected for electricity import/export and ambient temperature has decreased by 64.9 % since 1990, and the CO₂ emission by 65.5 %. These data are included here to explain the fluctuations in the emission time series.

CO₂

The carbon dioxide (CO₂) emission from stationary combustion plants is one of the most important sources of greenhouse gas emissions. Thus, the CO₂ emission from stationary combustion plants accounts for 40 % of the national CO₂ emission (LULUCF included). Table 3.2.4 lists the CO₂ emission inventory for stationary combustion plants for 2020. Public electricity and heat production accounts for 44 % of the CO₂ emission from stationary combustion. Other large CO₂ emission sources are Industry³ and Residential plants. These are the source categories, which also account for a considerable share of fuel consumption.

Table 3.2.4 CO₂ emission from stationary combustion plants, 2020¹⁾.

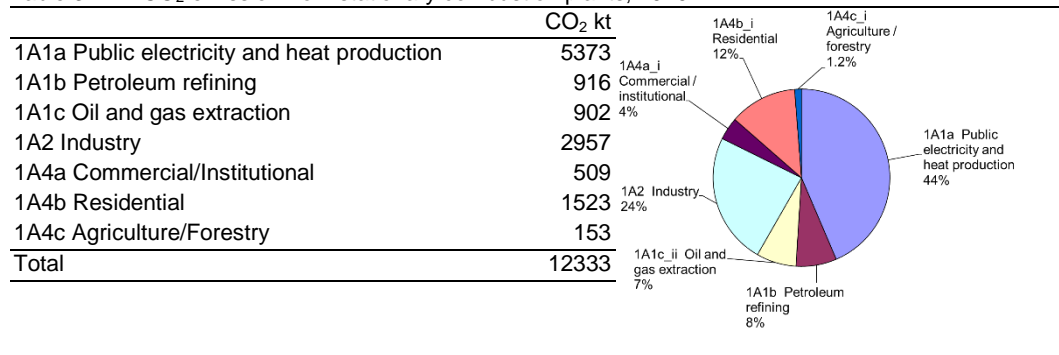

1) Only emissions from stationary combustion plants in the categories are included.

In the Danish inventory, the source category Public electricity and heat production is further disaggregated. The CO₂ emission from each of the subcategories is shown in Table 3.2.5. The largest subcategory is power plant boilers >300MW.

Table 3.2.5 CO₂ emission from subcategories to 1A1a Public electricity and heat production.

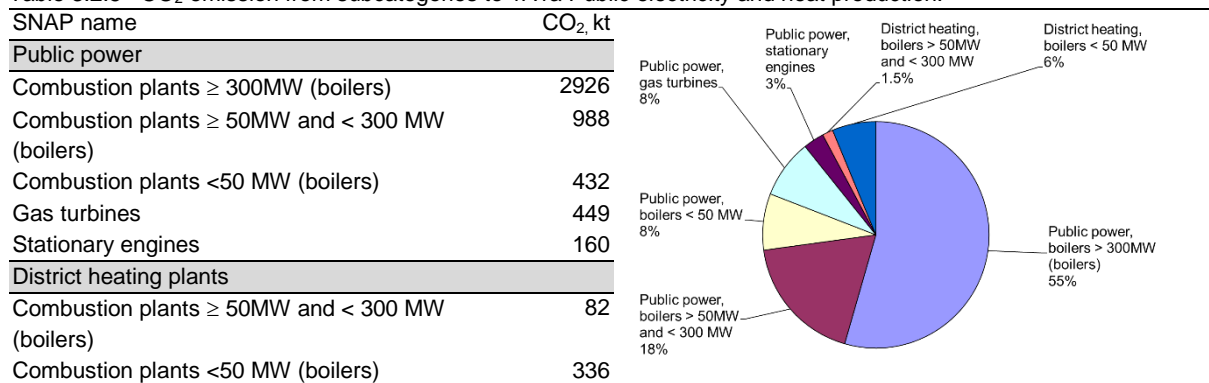

CO₂ emission from combustion of biomass fuels is not included in the total CO₂ emission data, because biomass fuels are considered CO₂ neutral. The CO₂ emission from biomass combustion is reported as a memo item in the Climate Convention reporting. In 2020, the CO₂ emission from biomass combustion from stationary combustion was 17 668 kt.

³ Includes only stationary combustion, whereas CO₂ from industrial processes e.g. calcination in cement production is included elsewhere.

In Figure 3.2.10, the fuel consumption share (fossil fuels) is compared to the CO₂ emission share disaggregated to fuel origin. Due to the higher CO₂ emission factor for coal than oil and gas, the CO₂ emission share from coal combustion is higher than the fuel consumption share.

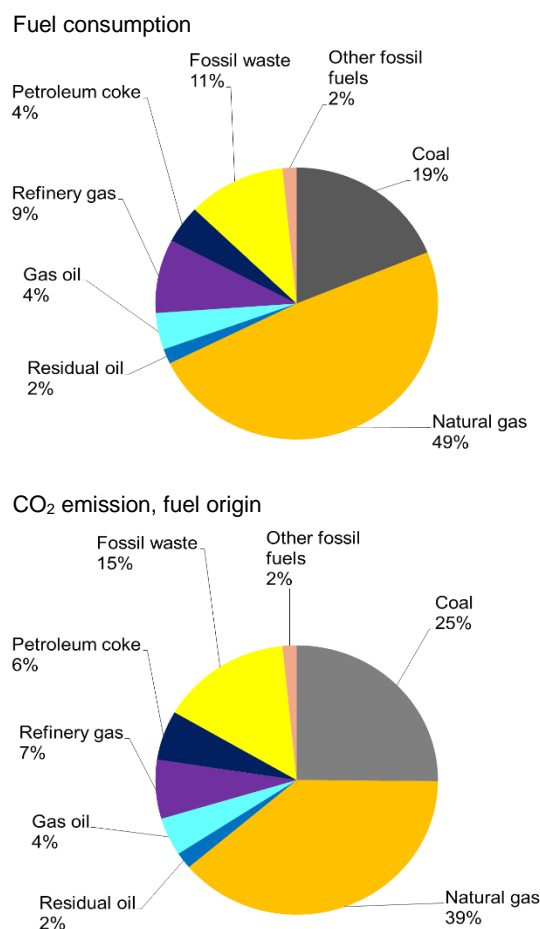

Figure 3.2.10 CO₂ emission, fuel origin.

The time series for CO₂ emission is provided in Figure 3.2.11. Despite a decrease in fuel consumption of 33 %⁴ since 1990, the CO₂ emission from stationary combustion has decreased by 68 % due to the change of fuel type used.

The fluctuations in total CO₂ emission follow the fluctuations in CO₂ emission from Public electricity and heat production (Figure 3.2.11) and in coal consumption (Figure 3.2.4). The fluctuations are a result of electricity import/export as discussed in Chapter 3.2.2.

⁴ The consumption of fossil fuels has decreased 63 %.

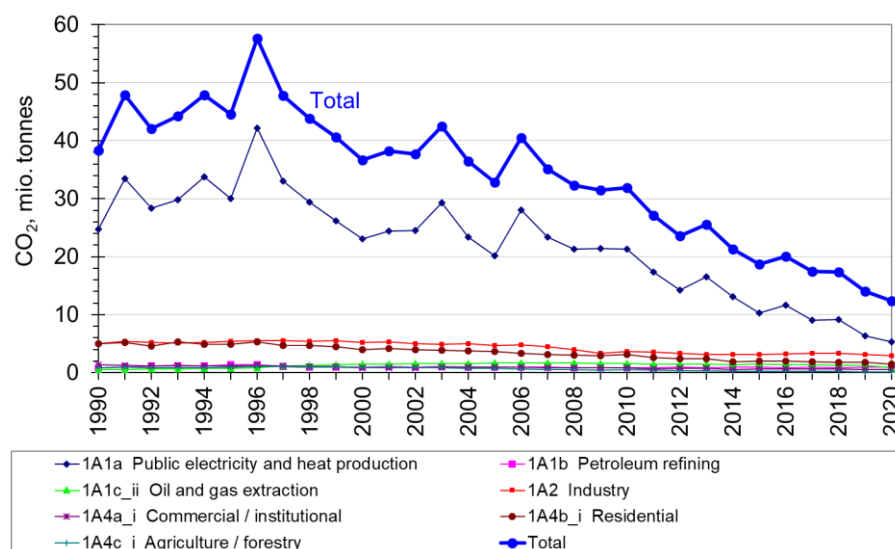
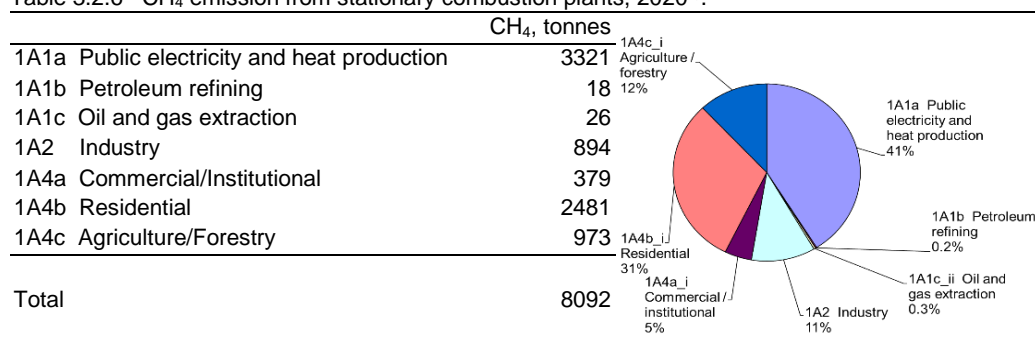

Figure 3.2.11 CO₂ emission time series for stationary combustion plants.

CH₄

The methane (CH₄) emission from stationary combustion plants accounts for 3.3 % of the national CH₄ emission. Table 3.2.6 lists the CH₄ emission inventory for stationary combustion plants in 2020. Public electricity and heat production accounts for 41 % of the CH₄ emission from stationary combustion. The emission from residential plants adds up to 31 % of the emission.

Table 3.2.6 CH₄ emission from stationary combustion plants, 2020¹⁾.



1) Only emission from stationary combustion plants in the source categories is included.

The CH₄ emission factor for reciprocating gas engines is much higher than for other combustion plants due to the continuous ignition/burn-out of the gas. Lean-burn gas engines have an especially high emission factor. A considerable number of lean-burn gas engines are in operation in Denmark and in 2020, these plants accounted for 52 % of the CH₄ emission from stationary combustion plants (Figure 3.2.12). Most engines are installed in CHP plants and the fuel used is either natural gas or biogas. Residential wood combustion is also a large emission source accounting for 19 % of the emission in 2020.

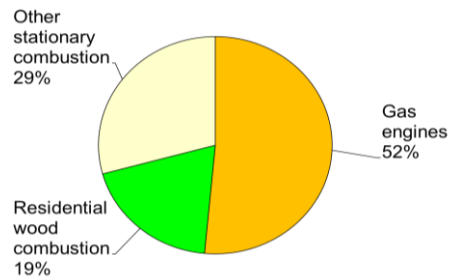

Figure 3.2.12 CH₄ emission share for gas engines and residential wood combustion, 2020.

Figure 3.2.13 shows the time series for CH₄ emission. The CH₄ emission from stationary combustion was 18 % higher in 2020 than in 1990. The emission increased until 1996 and decreased after 2004. This time series is related to the considerable number of lean-burn gas engines installed in CHP plants in Denmark during the 1990s. Figure 3.2.14 provides time series for the fuel consumption rate in gas engines and the corresponding increase of CH₄ emission. The decline in later years is due to structural changes in the Danish electricity market, which means that the fuel consumption in gas engines has been decreasing.

The CH₄ emission from residential plants was 48 % lower in 2020 than in 1990. For residential plants, the main emission source is combustion of biomass. The consumption of wood in residential plants has increased, whereas the emission factor for residential wood combustion has decreased due to implementation of new improved stoves and boilers. Combustion of wood (including wood pellets) accounted for 63 % of the CH₄ emission from residential plants in 2020.

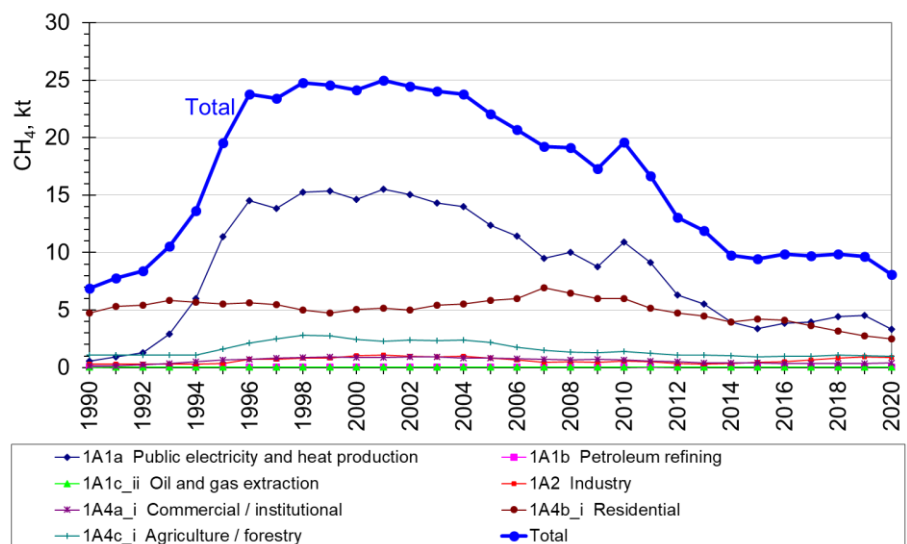
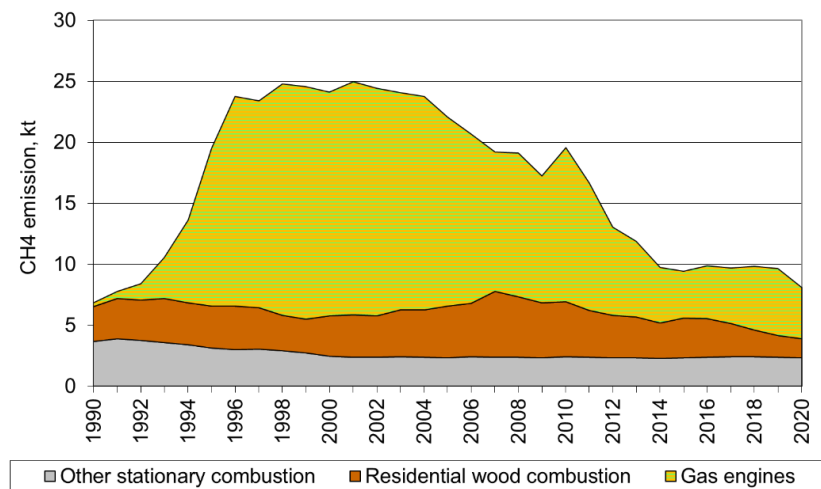
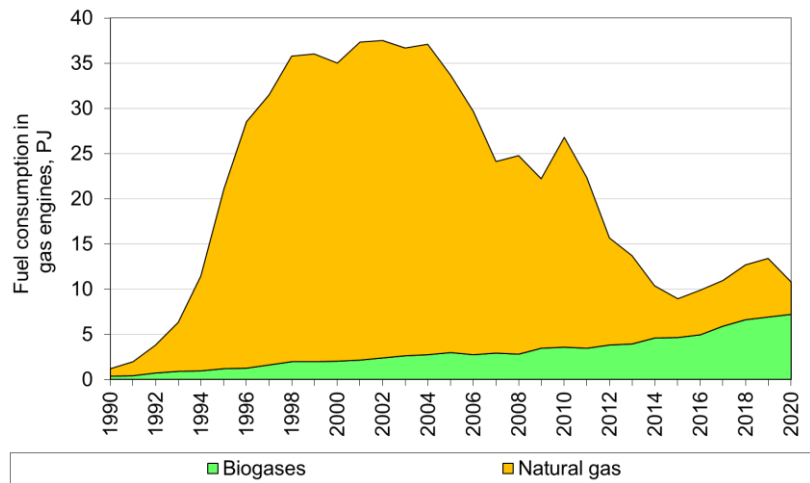

Figure 3.2.13 CH₄ emission time series for stationary combustion plants.



Figure

3.2.14 Time series for a) fuel consumption in gas engines and b) CH₄ emission from gas engines, residential wood combustion and other plants.

N₂O

The nitrous oxide (N₂O) emission from stationary combustion plants accounts for 3.1 % of the national N₂O emission. Table 3.2.7 lists the N₂O emission inventory for stationary combustion plants in the year 2020. Public electricity and heat production accounts for 39 % of the N₂O emission from stationary combustion.

Table 3.2.7 N₂O emission from stationary combustion plants, 2020¹⁾.

	N ₂ O, tonnes
1A1a Public electricity and heat production	235
1A1b Petroleum refining	4
1A1c Oil and gas extraction	15
1A2 Industry	158
1A4a Commercial/Institutional	17
1A4b Residential	160
1A4c Agriculture/Forestry	12
Total	601

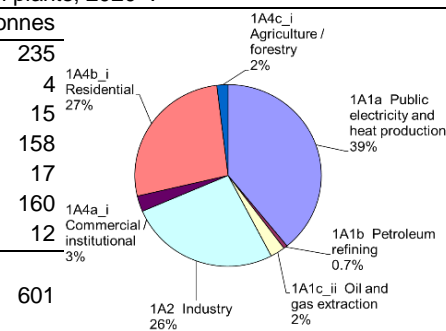

1) Only emission from stationary combustion plants in the source categories is included.

Figure 3.2.15 shows the time series for N₂O emission. The N₂O emission from stationary combustion was 3 % lower in 2020 than in 1990, but again fluctuations in emission level due to electricity import/export are considerable.

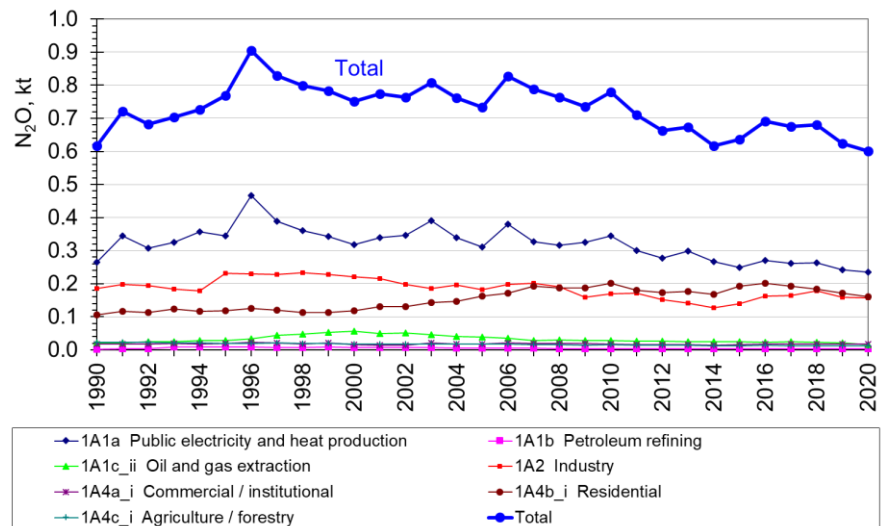

Figure 3.2.15 N₂O emission time series for stationary combustion plants.

SO₂, NO_x, NMVOC and CO

The emissions of sulphur dioxide (SO₂), nitrogen oxides (NO_x), non-volatile organic compounds (NMVOC) and carbon monoxide (CO) from Danish stationary combustion plants are included in the Danish IIR (Nielsen et al., 2022). Please refer to the Danish IIR for data presentation and references for SO₂, NO_x, NMVOC and CO.

3.2.4 Trend for subsectors

In addition to the data for stationary combustion, this chapter presents and discusses data for each of the subcategories in which stationary combustion is included. Time series are presented for fuel consumption and emissions.

1A1 Energy industries

The emission source category 1A1 Energy Industries consists of the subcategories:

- 1A1a Public electricity and heat production
- 1A1b Petroleum refining
- 1A1c Oil and gas extraction

Figure 3.2.16 – 3.2.17 present time series for the Energy Industries. Public electricity and heat production is the largest subcategory accounting for the main part of all emissions. Time series are discussed below for each subcategory.

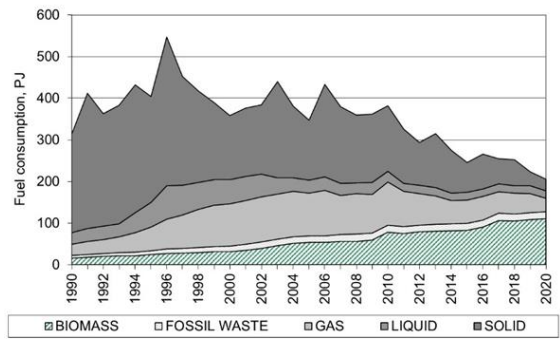
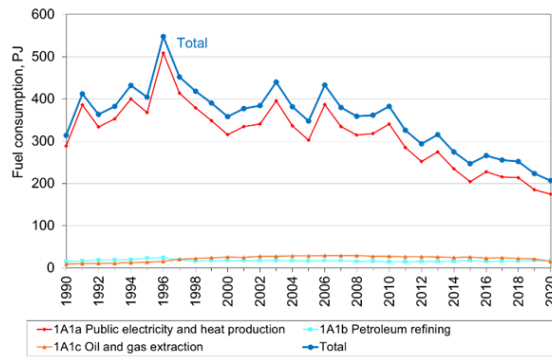

Natural gas fuelled engines

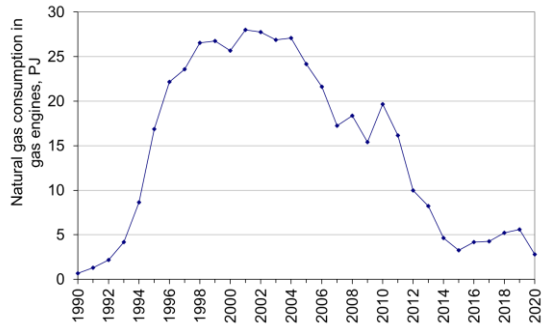

Biogas fuelled engines (biogas, bio gasification gas and bio natural gas)

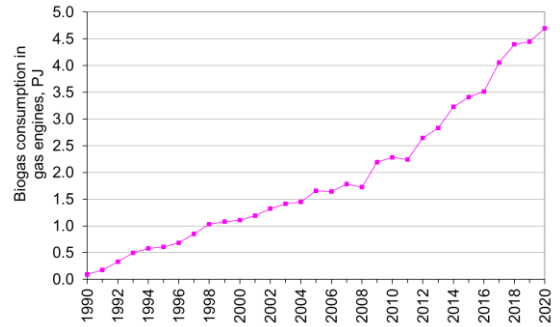

Residual oil in petroleum refining

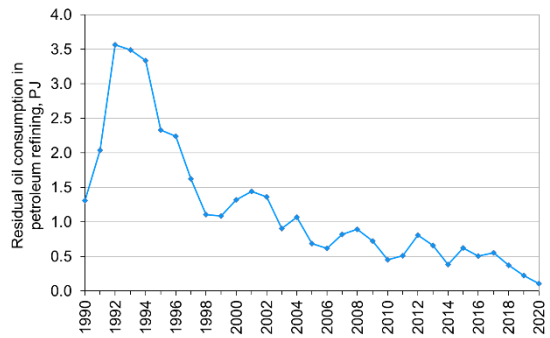

Figure 3.2.16 Time series for fuel consumption, 1A1 Energy industries.

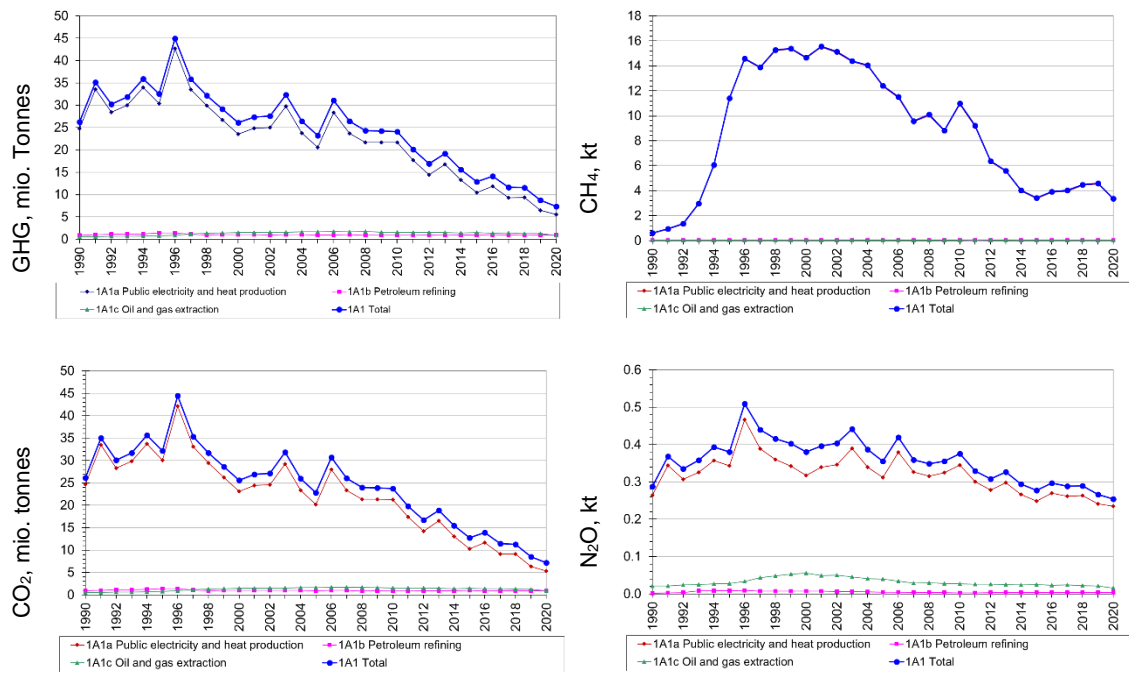

Figure 3.2.17 Time series for greenhouse gas emissions, 1A1 Energy industries.

1A1a Public electricity and heat production

Public electricity and heat production is the largest source category regarding both fuel consumption and greenhouse gas emissions for stationary combustion. Figure 3.2.18 shows the time series for fuel consumption and emissions.

The fuel consumption in public electricity and heat production was 40 % lower in 2020 than in 1990. In addition to fuel type changes, the total fuel consumption is also influenced by the fact that the Danish wind power production has increased.

As discussed in Chapter 3.2.2 the fuel consumption fluctuates mainly because of electricity trade. Coal is the fuel that is affected the most by the fluctuating electricity trade.

Coal was the main fuel in the source category in the 1990s, but the consumption has been decreasing in later years. The coal consumption in 2020 was only 12 % of the 1990 consumption in this sector. Natural gas is also an important fuel and the consumption of natural gas increased in 1990-2000 but has decreased since 2010. A considerable part of the natural gas is combusted in gas engines (Figure 3.2.17). The consumption of waste, biogas and biomass has increased.

The CO₂ emission was 78 % lower in 2020 than in 1990. This decrease – in spite of only a 40 % decrease in fuel consumption – is a result of the change of fuel types used.

The CH₄ emission has increase until the mid-nineties as a result of the considerable number of lean-burn gas engines installed in CHP plants in Denmark in this period. The decline after 2004 is due to structural changes in the Danish electricity market, which means that the fuel consumption in gas engines has been decreasing (Figure 3.2.17). The emission in 2020 was 5.7 times the 1990 emission level.

The N₂O emission in 2020 was 11 % lower than the 1990 emission level. The emission fluctuates similar to the fuel consumption.

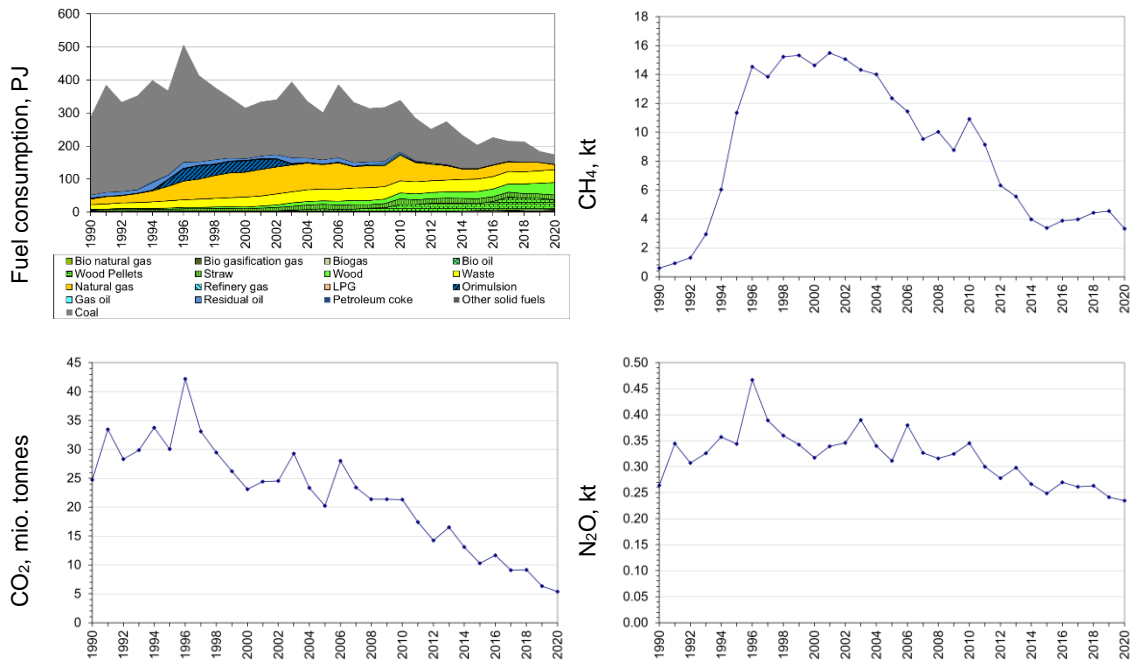

Figure 3.2.18 Time series for 1A1a Public electricity and heat production.

1A1b Petroleum refining

Petroleum refining is a small source category regarding both fuel consumption and emissions for stationary combustion. There are presently two refineries operating in Denmark. Figure 3.2.19 shows the time series for fuel consumption and emissions.

The significant decrease in both fuel consumption and emissions in 1996 is a result of the closure of a third refinery.

The fuel consumption has increased 5 % since 1990 and the CO₂ emission has increased 1 %.

The CH₄ emission has decreased 2 % since 1990. The reduction in CH₄ emission from 1995 to 1996 is caused by the closure of a refinery.

The N₂O emission was 82 % higher in 2020 than in 1990. The emission increased in 1993 as a result of the installation of a gas turbine in one of the refineries (DEA, 2021b).

The N₂O emission factor for the refinery gas fuelled gas turbine has been assumed equal to the emission factor for natural gas fuelled turbines. This emission factor decreases in the years 2000-2007. This cause the decrease of the N₂O emission in 2000-2007.

Emissions from refineries are further discussed in Chapter 3.5 and in Plejdrup et al. (2015).

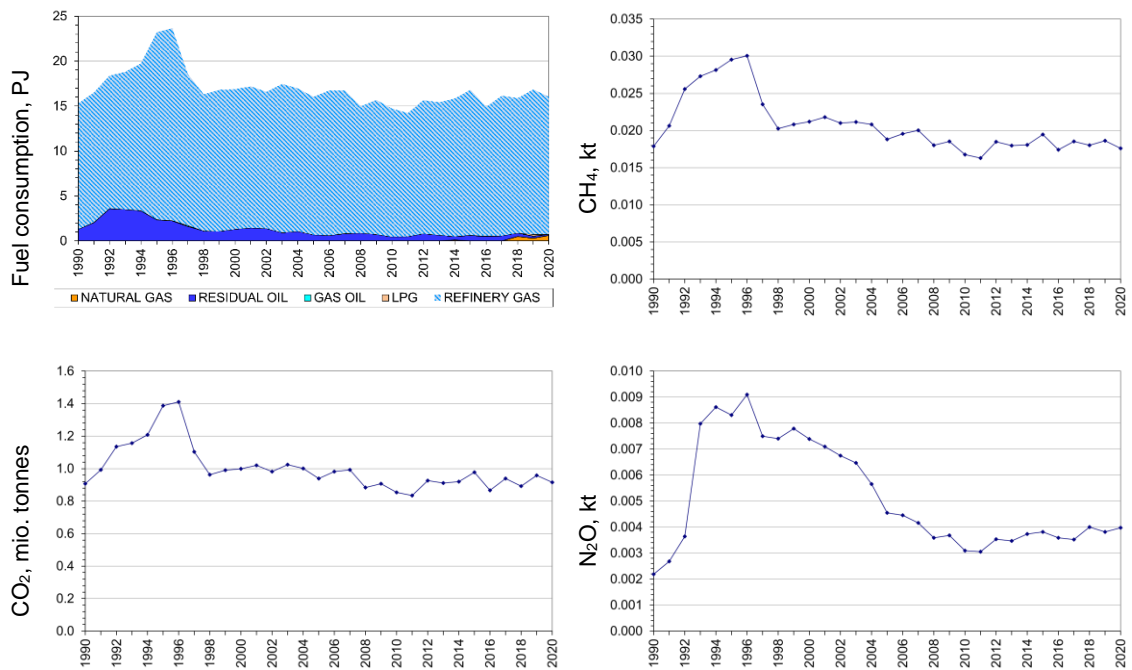

Figure 3.2.19 Time series for 1A1b Petroleum refining.

1A1c Oil and gas extraction

The source category Oil and gas extraction comprises natural gas consumption in the offshore industry. Gas turbines are the main plant type. In addition, a small consumption of gas oil in offshore plants and the fuel consumption in the Danish gas treatment plant⁵ are included in this subsector. Fugitive emissions from fuels are not included in the sector. Venting and flaring are included in the sector 1B2c Venting and Flaring.

Figure 3.2.20 shows the time series for fuel consumption and emissions.

The fuel consumption in 2020 was 63 % higher than in 1990. The fuel consumption has decreased since 2008. The large decrease between 2019 and 2020 is related to renovation of the largest gas field, Tyra. The CO₂ emission follows the fuel consumption and the emission in 2020 was 64 % higher in 2020 than in 1990.

The time series for N₂O emission follows the decreasing emission factor for gas turbines applied in CHP plants.

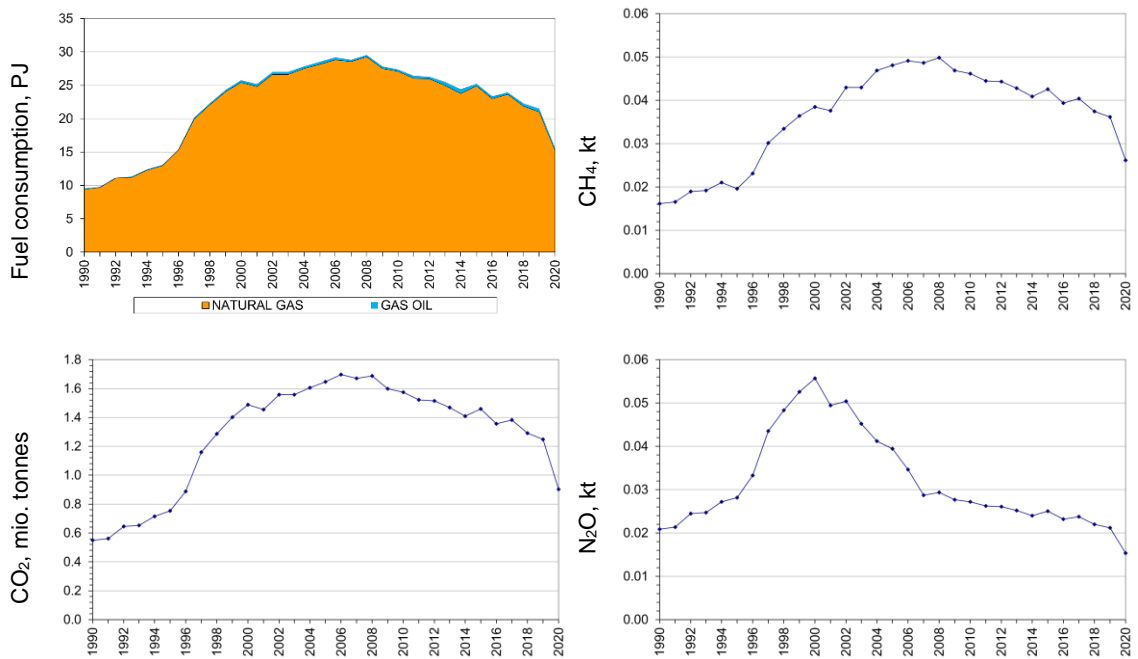

Figure 3.2.20 Time series for 1A1c Oil and gas extraction.

⁵ Nybro.

1A2 Industry

Manufacturing industries and construction (Industry) consists of both stationary and mobile sources. In this chapter, only stationary sources are included. Emissions from industrial processes e.g. calcination are not included in the sector stationary combustion.

The emission source category 1A2 Industry consists of the subcategories:

- 1A2a Iron and steel
- 1A2b Non-ferrous metals
- 1A2c Chemicals
- 1A2d Pulp, Paper and Print
- 1A2e Food processing, beverages and tobacco
- 1A2f Non-metallic minerals
- 1A2 g viii Other manufacturing industry

The figures 3.2.21-3.2.22 show the time series for fuel consumption and emissions. The subsectors Non-metallic minerals, Other manufacturing industry and Food processing, beverages and tobacco are the main subsectors for fuel consumption and emissions.

The total fuel consumption in industrial combustion was 25 % lower in 2020 than in 1990. The consumption of coal and liquid fossil fuels have decreased since 1990. The biomass consumption in 2020 was 2.0 times the consumption in 1990.

The greenhouse gas emission and the CO₂ emission are both rather stable until 2006 following the small fluctuations in fuel consumption. The emission decreased in 2006-2009. Due to change of applied fuels, the greenhouse gas and CO₂ emissions have decreased more than the fuel consumption since 1990; The GHG emission has decreased 40 % since 1990 and the CO₂ emission has decreased 41 %.

The CH₄ emission has increased from 1994-2001, decreased from 2001 – 2007 and increased again from 2013-2019. In 2020, the emission was 3.3 times the emission level in 1990. The CH₄ emission follows the consumption of natural gas and biogas in gas engines (Figure 3.2.21). Most industrial CHP plants based on gas engines came in operation in the years 1995 to 1999. The decrease after 2004 is a result of the liberalisation of the electricity market. The increased emission after 2013 is related to new biogas fuelled gas engines in the food industry.

The N₂O emission has decreased 15 % since 1990. The emission from mineral wool production⁶ is a large emission source, and the production of mineral wool production has increased in recent years (see Chapter 4.2.9). This cause the increase of the N₂O emission in 2014-2018.

The increase of N₂O emission from 1994 to 1995 is related to combustion of coke oven coke in mineral wool production. Plant specific fuel consumption data are only available from 1995 onwards for the mineral wool production plants.

⁶ Included in sector 1A2f Non-metallic minerals.

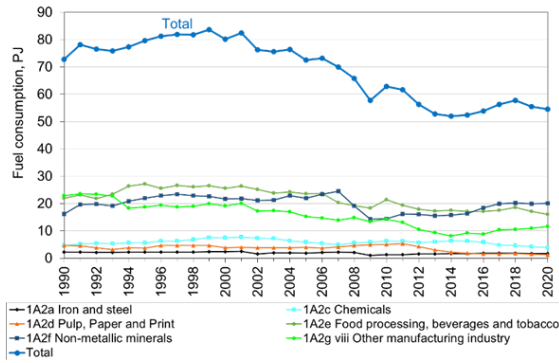

Fuel consumption in gas fuelled engines

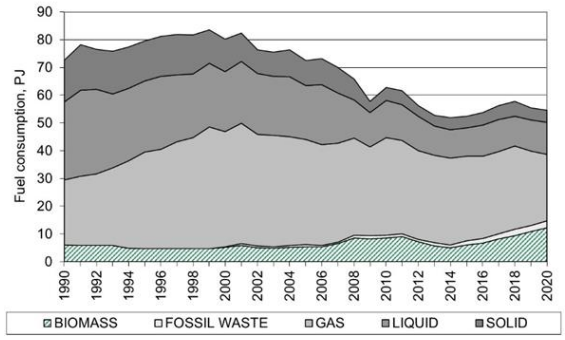
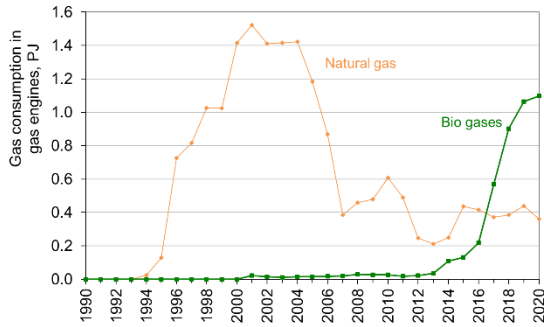

Fuel consumption, residual oil and wood

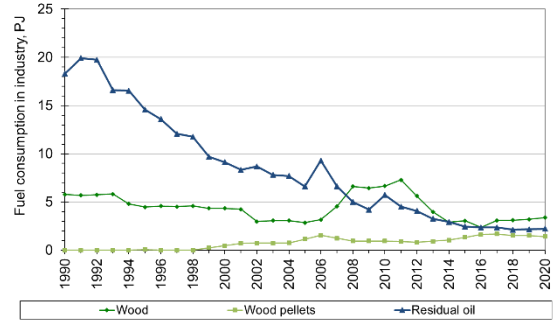

Figure 3.2.21 Time series for fuel consumption, 1A2 Industry.

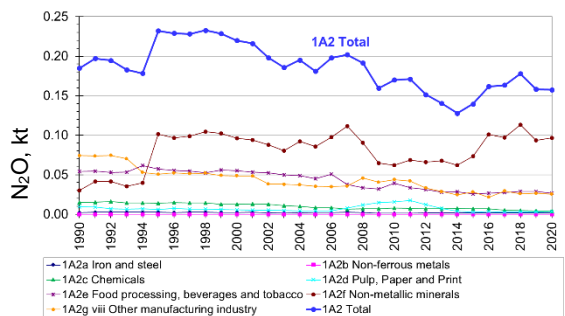
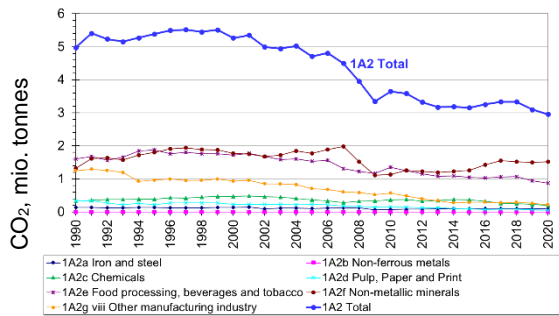
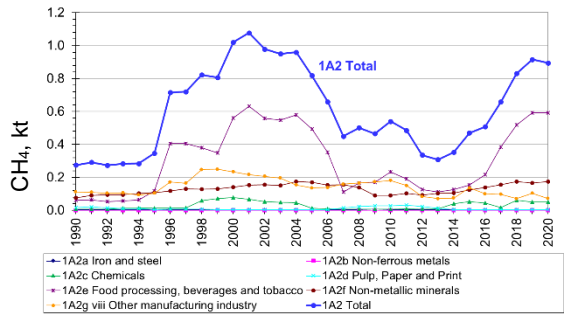
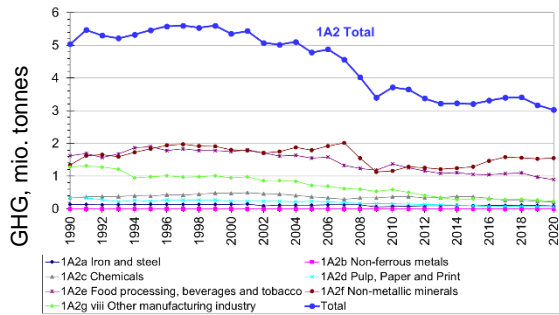

Figure 3.2.22 Time series for greenhouse gas emission, 1A2 Industry.

1A2a Iron and steel

Iron and steel is a very small emission source category. Figure 3.2.23 shows the time series for fuel consumption and emissions.

Natural gas is the main fuel in the subsector.

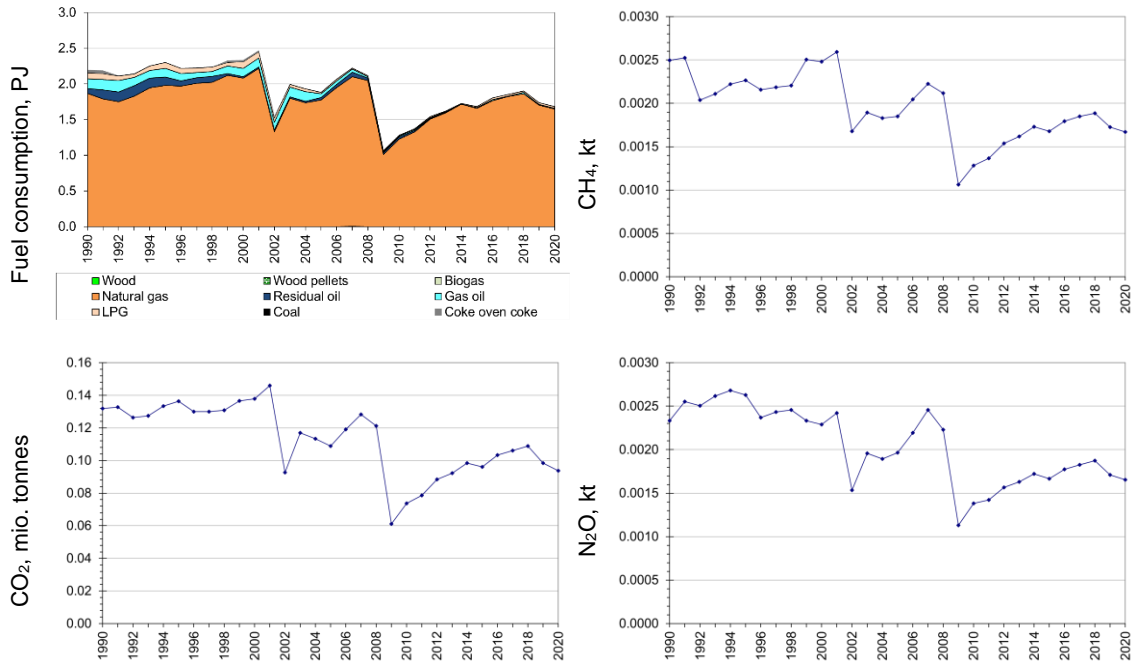

Figure 3.2.23 Time series for 1A2a Iron and steel.

1A2b Non-ferrous metals

No fuel consumption is reported for non-ferrous metals in the Danish energy statistics.

1A2c Chemicals

Chemicals is a minor emission source category. Figure 3.2.24 shows the time series for fuel consumption and emissions.

Natural gas is the main fuel in this subsector. The CO₂ emission time series follow the time series for fuel consumption. The time series for CH₄ emission 1997-2006 is related to consumption of natural gas in gas engines. The increased CH₄ emission in 2014 to 2020 is related to one biogas fuelled engine. The decreasing time series for N₂O emission is related to the decreasing consumption of residual oil.

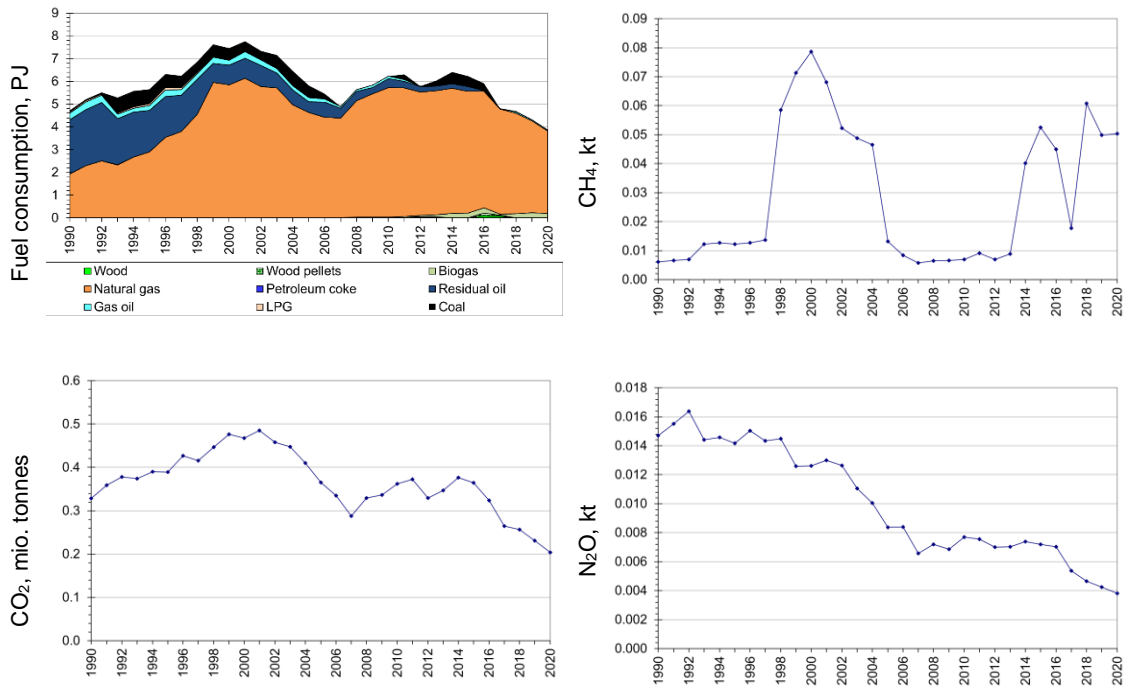

Figure 3.2.24 Time series for 1A2c Chemicals.

1A2d Pulp, paper and print

Pulp, paper and print is a minor emission source category. Figure 3.2.25 shows the time series for fuel consumption and emissions.

The fuel consumption decreased 71 % from 1990. The time series is related to both closure of plants and new combustion units in exiting plants. In addition, the liberalisation of the electricity market caused less operational hours of a natural gas fuelled gas turbine. Natural gas, and in 2007-2013 also wood, are the main fuels in the subsector.

The increased consumption of wood in 2007-2013 is reflected in the CH₄ and N₂O emission time series.

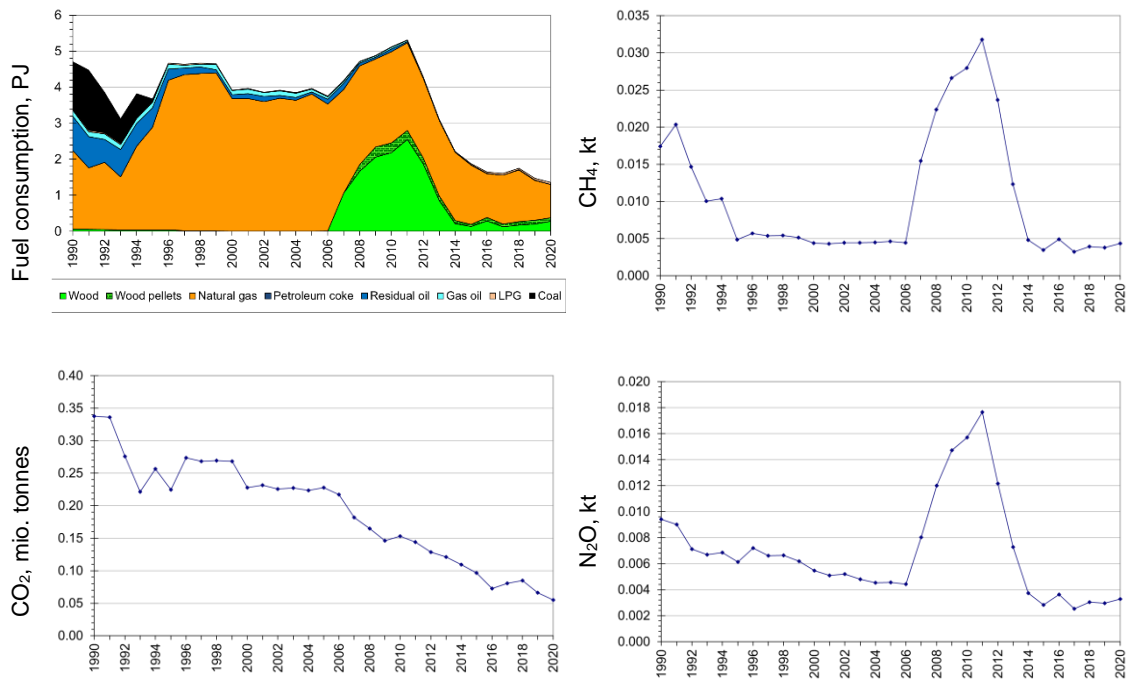

Figure 3.2.25 Time series for 1A2d Pulp, paper and print.

1A2e Food processing, beverages and tobacco

Food processing, beverages and tobacco is a considerable industrial subsector. Figure 3.2.26 shows the time series for fuel consumption and emissions.

Natural gas, residual oil and coal are the main fuels in the subsector. The consumption of coal and residual oil has decreased whereas the consumption of natural gas has increased.

The time series for CH₄ emission follows the consumption of natural gas in gas engines.

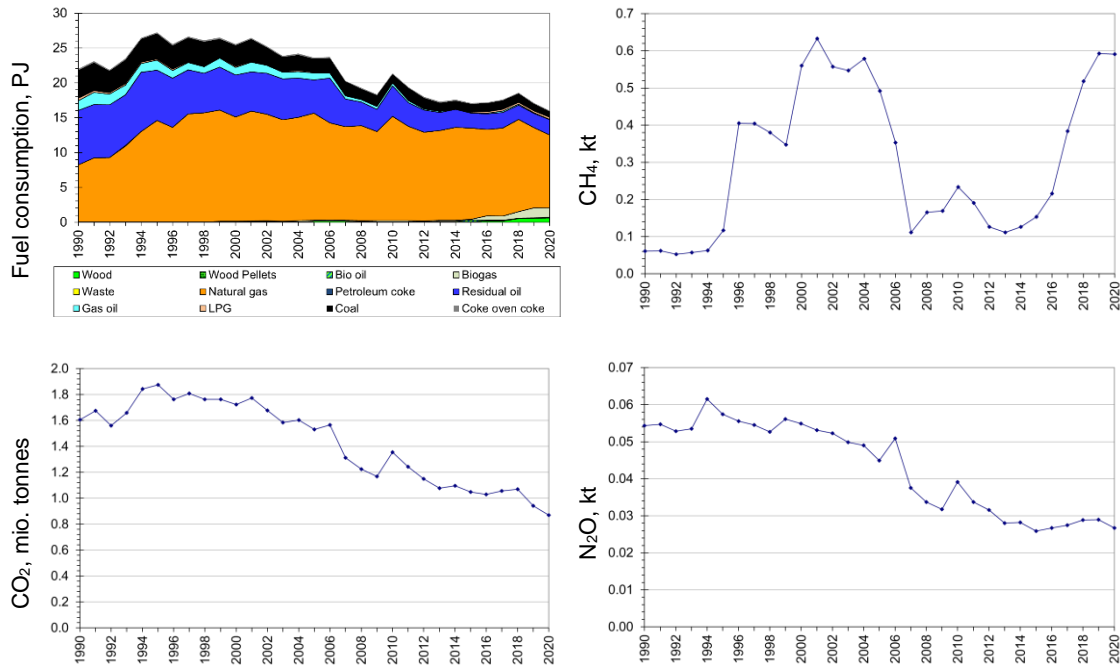

Figure 3.2.26 Time series for 1A2e Food processing, beverages and tobacco.

1A2f Non-metallic minerals

Non-metallic minerals is a considerable industrial subsector. The subsector includes cement production that is a major industrial emission source in Denmark. Production of mineral wool and glass is also included in the subsector. Figure 3.2.27 shows the time series for fuel consumption and emissions.

Petroleum coke, natural gas, waste and coal are the main fuels in the subsector in recent years. The consumption of coal has decreased.

Due to the global recession, cement production decreased in 2008 and 2009, but then increased again. This is reflected in the time series.

Combustion of coke oven coke in mineral wool production is a large emission source for N₂O. Plant specific fuel consumption rates for the mineral wool production plants are available from 1995. This causes the increase in N₂O emission between 1994 and 1995.

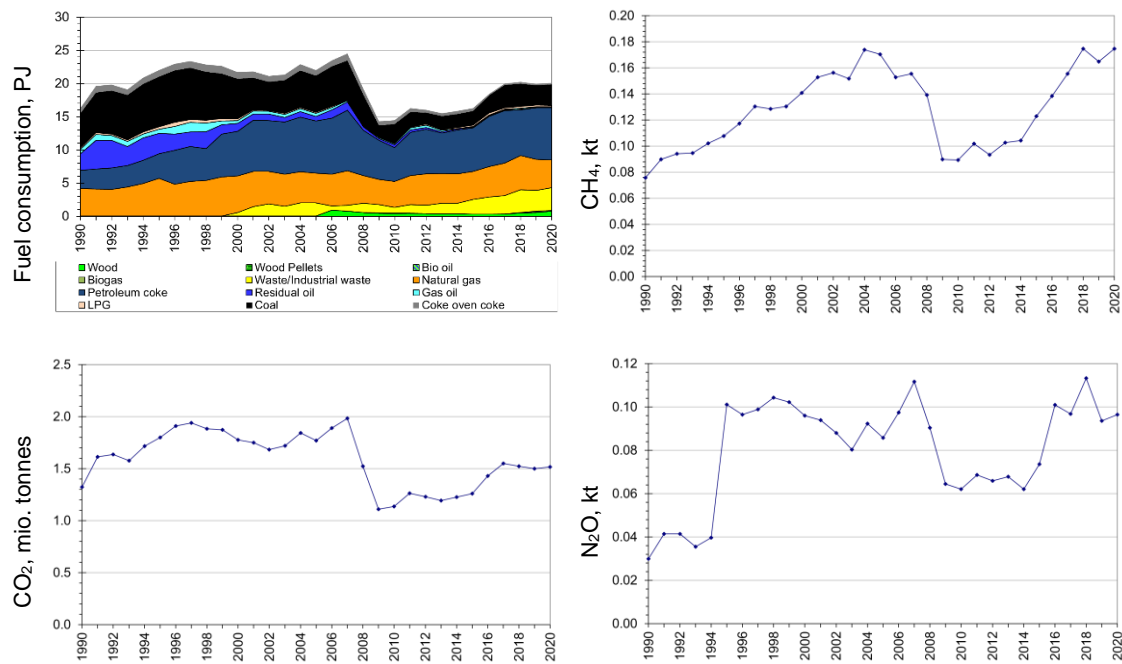

Figure 3.2.27 Time series for 1A2f Non-metallic minerals.

1A2g Other manufacturing industry

Other manufacturing industry is a considerable industrial subsector. Figure 3.2.28 shows the time series for fuel consumption and emissions.

Natural gas, bio natural gas (bio methane) and wood are the main fuels in the subsector in recent years⁷. The consumption of coal and oil has decreased.

The time series for CH₄ is related to the consumption of natural gas in gas engines.

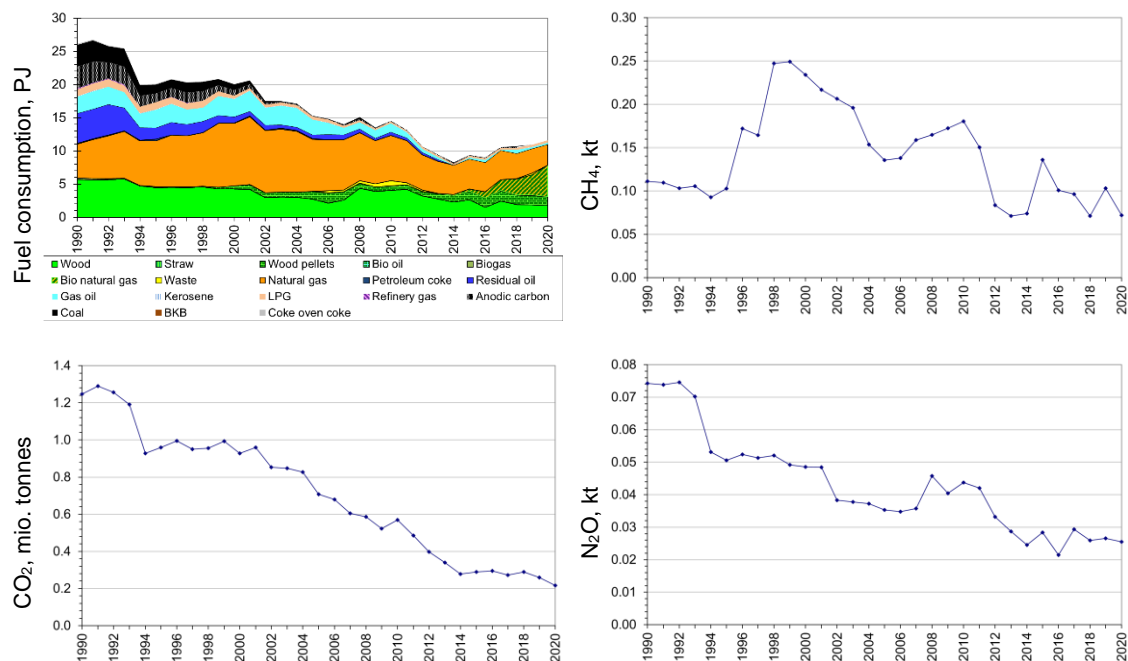

Figure 3.2.28 Time series for 1A2g Industry - other.

⁷ In recent years, the consumption of bio natural gas included in this sector is also high. All bio natural gas applied in industrial plants is included in subsector 1A2g Industry - other. Thus, the bio natural gas share of grid gas is high for this subsector.

1A4 Other Sectors

The emission source category 1A4 Other Sectors consists of the subcategories:

- 1A4a Commercial/Institutional plants.
- 1A4b Residential plants.
- 1A4c Agriculture/Forestry.

The Figures 3.2.29-30 present time series for this emission source category. Residential plants are the dominant subcategory accounting for the largest part of all emissions. Time series are discussed below for each subcategory.

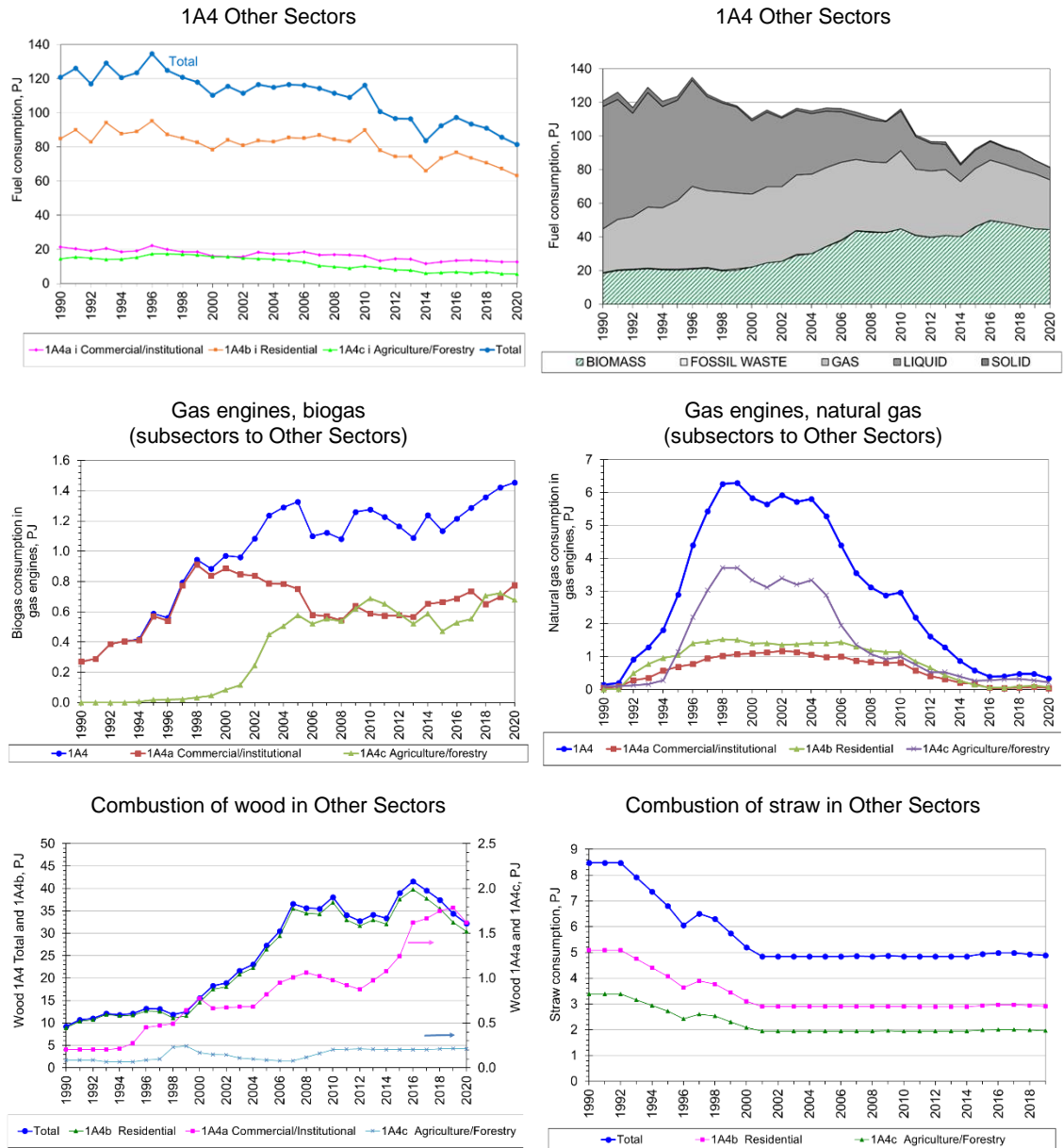

Figure 3.2.29 Time series for fuel consumption, 1A4 Other Sectors.

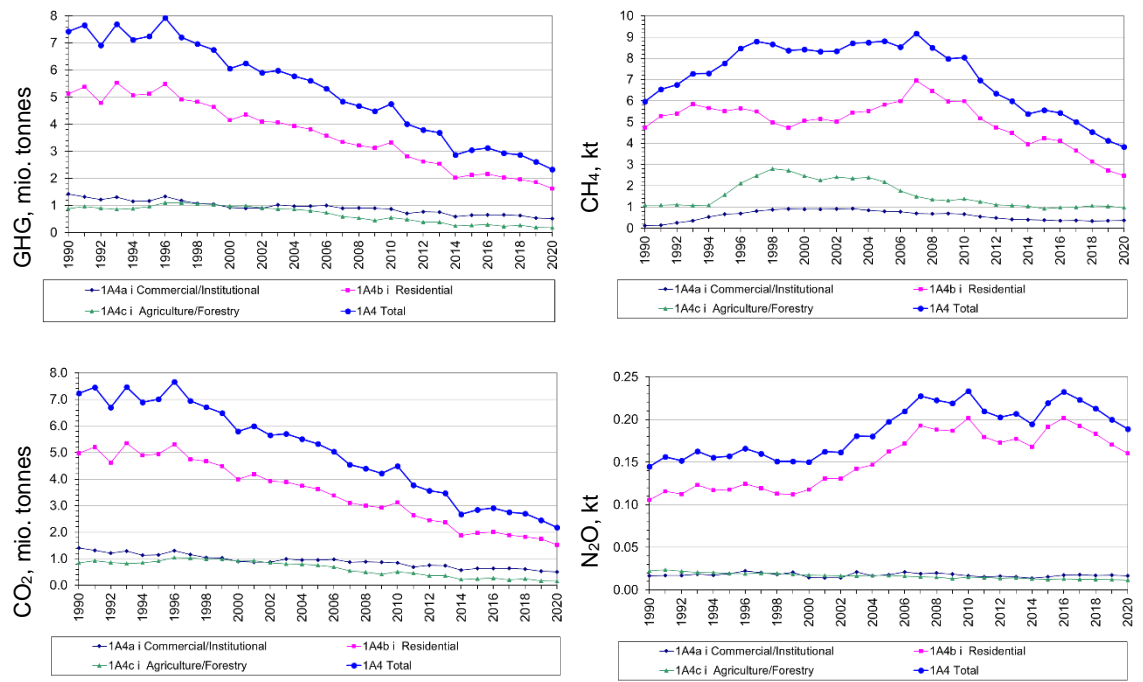

Figure 3.2.30 Time series for greenhouse gas emission, 1A4 Other Sectors.

1A4a Commercial and institutional plants

The subcategory Commercial and institutional plants consists of both stationary and mobile sources. In this chapter, only stationary sources are included. Figure 3.2.31 shows the time series for fuel consumption and emissions.

The subcategory Commercial and institutional plants has low fuel consumption and emissions compared to the other stationary combustion emission source categories.

The fuel consumption in Commercial/institutional plants has decreased 41 % since 1990 and the fuels applied have changed. The fuel consumption consists mainly of gas oil and natural gas. The consumption of gas oil has decreased since 1990. The consumptions of wood, biogas and bio natural gas (bio methane) have increased. The wood consumption in 2020 was 7.9 times the consumption in 1990.

The CO₂ emission has decreased 64 % since 1990. Both the decrease of fuel consumption and the change of fuels contribute to the decreased CO₂ emission.

The CH₄ emission in 2020 was 2.9 times the 1990 level. The increase is mainly a result of the increased emission from natural gas fuelled engines. The emissions from biogas-fuelled engines and from combustion of wood also contribute to the increase. The time series for consumption of natural gas and biogas are shown in Figure 3.2.29.

The N₂O emission in 2020 was equal to the emission in 1990. The fluctuations of the N₂O emission are mainly a result of fluctuations in consumption of natural gas and waste.

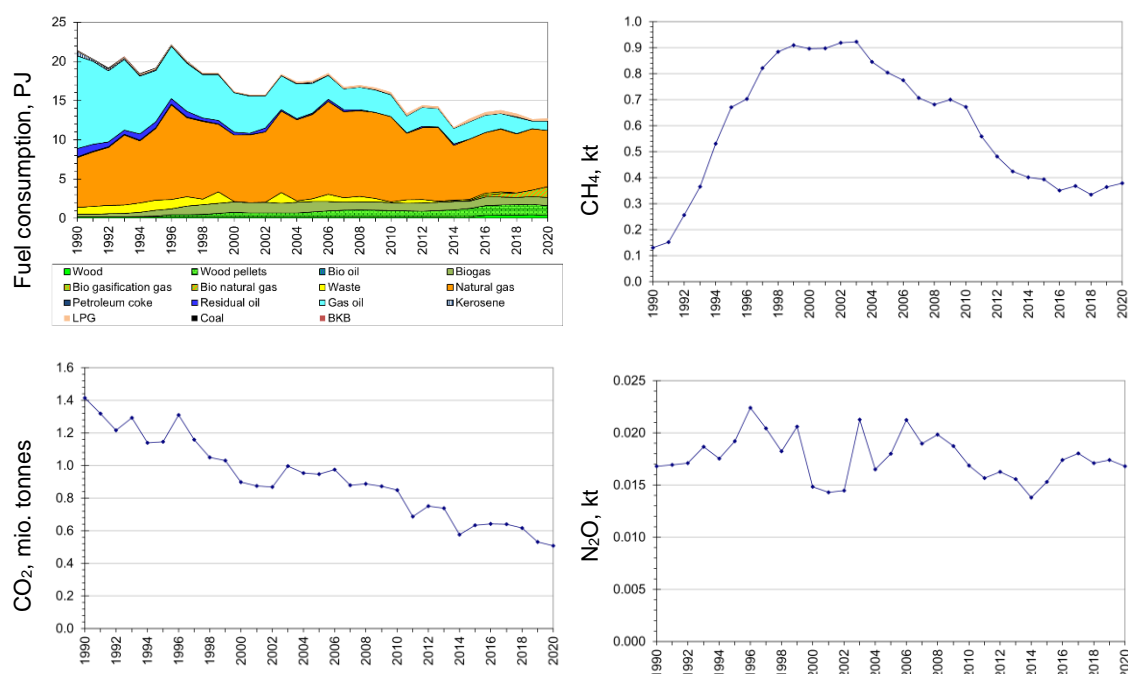

Figure 3.2.31 Time series for 1A4a Commercial /institutional.

1A4b Residential plants

The emission source category Residential plants consists of both stationary and mobile sources. In this chapter, only stationary sources are included. Figure 3.2.32 shows the time series for fuel consumption and emissions.

For residential plants, the total fuel consumption was 26 % lower in 2020 than in 1990. The large decrease from 2010 to 2011 was caused by high temperature in the winter season of 2011 compared to the cold winter of 2010. The consumption of gas oil has decreased since 1990 whereas the consumption of wood, wood pellets and bio natural gas has increased considerably.

The CO₂ emission has decreased by 69 % since 1990. This decrease is mainly a result of the considerable change in fuels used from gas oil to log wood, wood pellets, bio natural gas and natural gas.

The CH₄ emission from residential plants was 48 % lower in 2020 than in 1990. Residential wood combustion is a large source of CH₄ emission, and the consumption of wood has increased whereas the emission factor has decreased since 1990. Replacement of older stoves and boilers with new improved stoves and boilers cause a lower CH₄-emission factor for residential wood combustion, see also Chapter 3.2.5.

The change of fuel from gas oil to wood has resulted in a 52 % increase of N₂O emission since 1990 due to a higher emission factor for wood than for gas oil.

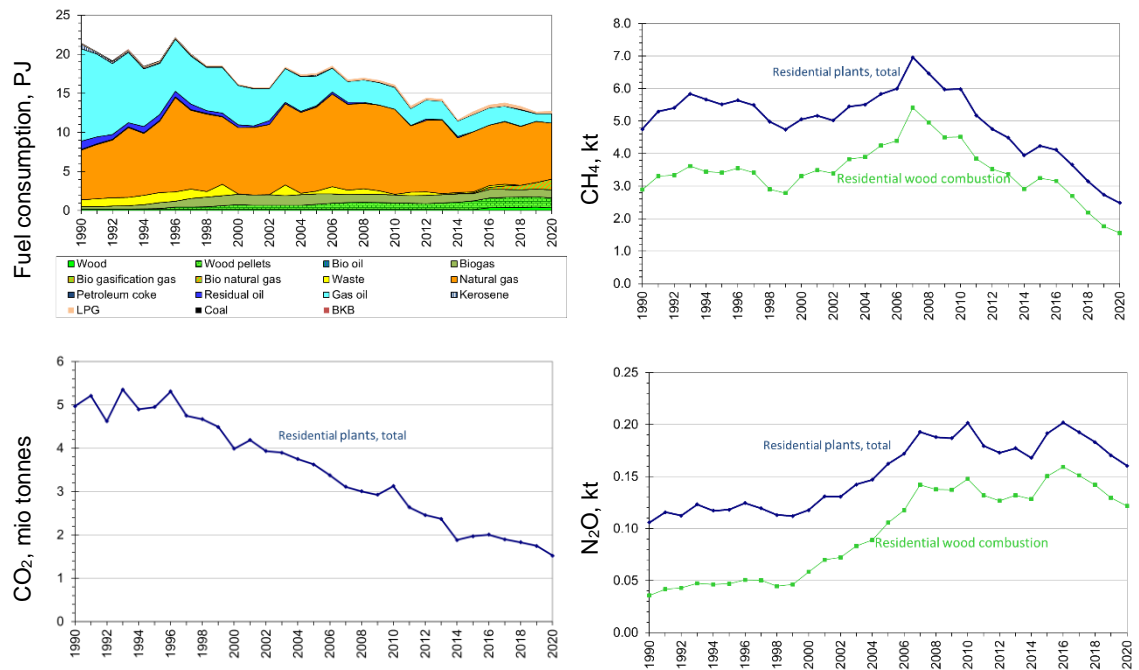

Figure 3.2.32 Time series for 1A4b Residential plants.

1A4c Agriculture/forestry

The emission source category Agriculture/forestry consists of both stationary and mobile sources. In this chapter, only stationary sources are included. Figure 3.2.33 shows the time series for fuel consumption and emissions.

For plants in Agriculture/forestry, the fuel consumption has decreased 62 % since 1990.

The type of fuel that has been applied has changed since 1990. In the years 1994-2004, the consumption of natural gas was high, but after 2004, the consumption decreased again. A large part of the natural gas consumption has been applied in gas engines (Figure 3.2.29). Most CHP plants in Agriculture/forestry based on gas engines came in operation in 1995-1999. The decrease after 2004 is a result of the liberalisation of the electricity market.

The consumption of coal, residual oil and straw has decreased since 1990. The consumption of biogas has increased.

The CO₂ emission in 2020 was 82 % lower than in 1990. The CO₂ emission increased from 1990 to 1996 due to increased fuel consumption. Since 1996, the CO₂ emission has decreased in line with the decrease in fuel consumption.

The CH₄ emission in 2020 was 11 % lower than in 1990. The emission follows the time series for natural gas combusted in gas engines (Figure 3.2.29). The emission from combustion of straw has decreased as a result of the decreasing consumption of straw in the sector.

The emission of N₂O has decreased by 48 % since 1990. The decrease is a result of the lower fuel consumption as well as the change of fuel. The decreasing consumption of straw contributes considerably to the decrease of emission.

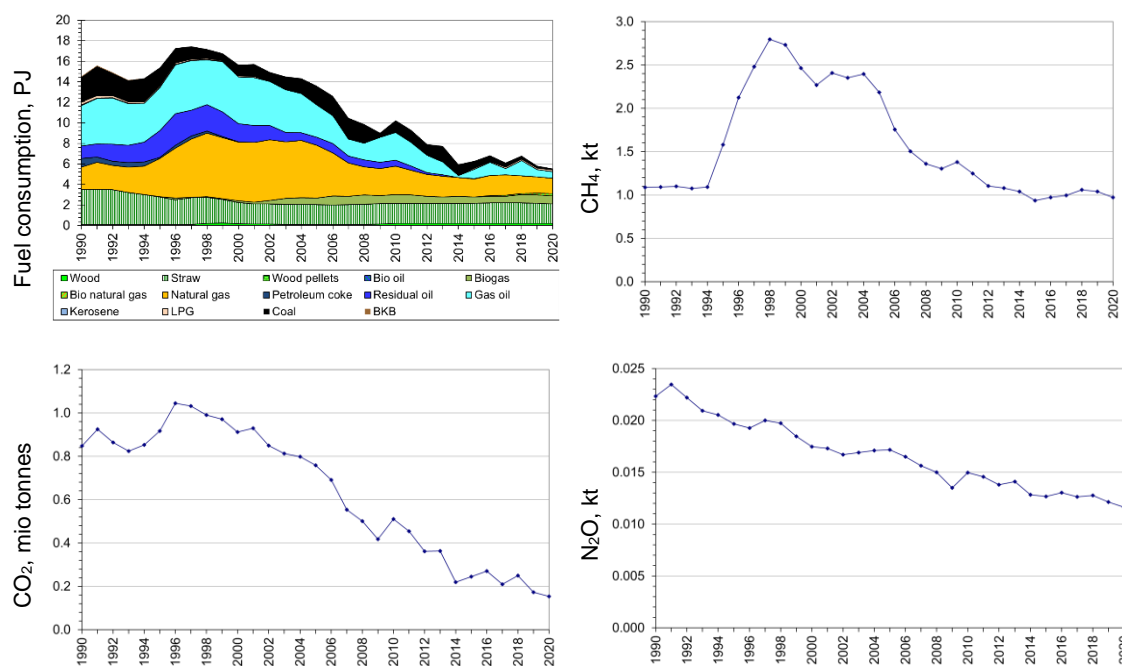

Figure 3.2.33 Time series for 1A4c Agriculture/Forestry.

3.2.5 Methodological issues

The Danish emission inventory is based on the CORINAIR (CORE INventory on AIR emissions) system, which is a European program for air emission inventories. CORINAIR includes methodology structure and software for inventories. The methodology is described in the EEA Guidebook (EEA, 2019). Emission data are stored in MS Access databases, from which data are transferred to the reporting formats.

In the Danish emission database, all activity rates and emissions are defined in SNAP sector categories (Selected Nomenclature for Air Pollution) according to the CORINAIR system. The emission inventories are prepared from a complete emission database based on the SNAP source categories. Aggregation to the source category codes used in CRF is based on a correspondence list enclosed in Annex 3A-1.

The emission inventory for stationary combustion is based on activity rates from the Danish energy statistics. General emission factors for various fuels, plants and sectors have been determined. Some large plants, such as power plants, are registered individually as large point sources and plant-specific emission data are used.

Recalculations and improvements are shown in Chapter 3.2.8 and 3.2.9

Tiers

The type of GHG emission factor and the applied tier level for each emission source are shown in Table 3.2.8 below. The tier levels have been determined based on the IPCC Guidelines (IPCC, 2006). The fuel consumption data for transformation are technology specific. For end-use of fuels, the disaggregation to specific technologies is less detailed. However, for residential wood combustion technology specific fuel consumption rates have been estimated.

The tier level definitions have been interpreted as follows:

- Tier 1: The emission factor is an IPCC default tier 1 value.
- Tier 2: The emission factors are country-specific and based on a limited number of emission measurements or a technology specific IPCC tier 2 emission factor.
- Tier 3: Emission data are based on:
 - plant specific emission measurements or
 - technology specific fuel consumption data and country-specific emission factors based on a considerable number of emission measurements from Danish plants.

Table 3.2.8 gives an overview of the calculation methods and type of emission factor. The table also shows which of the source categories are key in any of the key category analysis (including LULUCF, approach 1/approach 2, level/trend)⁸.

This year, two source categories based on tier 1 approach have been identified as key sources. The total emission from these emission sources adds up to 39

⁸ Key category according to the KCA approach 1 or approach 2 for Denmark (excluding Greenland and Faroe Islands), including LULUCF, level 1990/ level 2020/ trend.

kton CO₂ equivalent or 0.09 % of the national total in 2020. In 1990, the emission from the two emission sources adds up to 378 kton or 0.5 % of national total.

The 1990 CO₂ emission from kerosene was also identified as a key category last year, and thus implementation of a tier 2 methodology has been considered. The consumption of kerosene in stationary combustion plants was high in 1990 compared to the years before and after. The high consumption is related to the time series in the Danish energy statistics for kerosene consumption in Single family houses. In 1990, this consumption was 6 times the consumption in 1989 and 9 times the consumption in 1991. The Danish Energy Agency have been asked to explain the high consumption in 1990 but has not been able to confirm that this is due to an error, and thus data will not be revised (Zarnaghi, 2021).

N₂O emission from residential wood combustion is a key source, and if possible, a tier 2 emission factor will be implemented in future inventories.

Table 3.2.8 Methodology and type of emission factor, 2020.

		Tier	EMF ¹⁾	Key category ²⁾
1A Stationary combustion, Coal, ETS data	CO ₂	Tier 3	PS	Yes
1A Stationary combustion, Coal, no ETS data	CO ₂	Tier 3 ³⁾	CS	Yes
1A Stationary combustion, BKB	CO ₂	Tier 1	D	No
1A Stationary combustion, Coke oven coke	CO ₂	Tier 1/Tier 3	D/PS	No
1A Stationary combustion, Fossil waste, ETS data	CO ₂	Tier 3	PS	Yes
1A Stationary combustion, Fossil waste, no ETS data	CO ₂	Tier 2	CS	Yes
1A Stationary combustion, Petroleum coke, ETS data	CO ₂	Tier 3	PS	Yes
1A Stationary combustion, Petroleum coke, no ETS data	CO ₂	Tier 2	CS	Yes
1A Stationary combustion, Residual oil, ETS data	CO ₂	Tier 3	PS	Yes
1A Stationary combustion, Residual oil, no ETS data	CO ₂	Tier 2 ⁴⁾	CS	Yes
1A Stationary combustion, Gas oil	CO ₂	Tier 2/Tier 3 ⁵⁾	CS / PS	Yes
1A Stationary combustion, Kerosene	CO ₂	Tier 1	D	Yes
1A Stationary combustion, LPG	CO ₂	Tier 2/Tier 3 ⁶⁾	CS / PS	Yes
1A1b Stationary combustion, Petroleum refining, Refinery gas	CO ₂	Tier 3	CS	Yes
1A Stationary combustion, Natural gas, onshore	CO ₂	Tier 3	CS	Yes
1A1c_ii Stationary combustion, Oil and gas extraction, Offshore gas turbines, Natural gas	CO ₂	Tier 3	CS	Yes
1A1 Stationary Combustion, solid fuels	CH ₄	Tier 2	D(2)	No
1A1 Stationary Combustion, liquid fuels	CH ₄	Tier/Tier 2	D / D(2) / CS	No
1A1 Stationary Combustion, not engines, gaseous fuels	CH ₄	Tier 2	CS / D(2)	No
1A1 Stationary Combustion, waste	CH ₄	Tier 2	CS	No
1A1 Stationary Combustion, not engines, biomass	CH ₄	Tier 3/Tier 2/Tier 1	CS / D(2) / D	No
1A2 Stationary Combustion, solid fuels	CH ₄	Tier 1	D	No
1A2 Stationary Combustion, liquid fuels	CH ₄	Tier 1/Tier 2	D / D(2) / CS	No
1A2 Stationary Combustion, not engines, gaseous fuels	CH ₄	Tier 2	CS / D(2)	No
1A2 Stationary Combustion, waste	CH ₄	Tier 1	D	No
1A2 Stationary Combustion, not engines, biomass	CH ₄	Tier 2/Tier 1	D(2) / D	No
1A4 Stationary Combustion, solid fuels	CH ₄	Tier 1	D	No
1A4 Stationary Combustion, liquid fuels	CH ₄	Tier 1/Tier 2	D / D(2)	No
1A4 Stationary Combustion, not engines, gaseous fuels	CH ₄	Tier 2	D(2)	No
1A4 Stationary Combustion, waste	CH ₄	Tier 1	D	No
1A4 Stationary Combustion, not engines, not residential wood and not residential/agricultural straw, biomass	CH ₄	Tier 1/Tier 2	D / D(2) / CS	No
1A4b_i Stationary combustion, Residential wood combustion	CH ₄	Tier 2	CS	No
1A4b_i/1A4c_i Stationary Combustion, Residential and agricultural straw combustion	CH ₄	Tier 1	D	No
1A Stationary combustion, Natural gas fuelled engines, gaseous fuels	CH ₄	Tier 3	CS	No
1A Stationary combustion, Biogas fuelled engines, biomass	CH ₄	Tier 3	CS	No
1A1 Stationary Combustion, solid fuels	N ₂ O	Tier 2	CS / D(2)	Yes
1A1 Stationary Combustion, liquid fuels	N ₂ O	Tier 2/Tier 1	D(2) / CS / D	No
1A1 Stationary Combustion, gaseous fuels	N ₂ O	Tier 3/Tier 2	CS / D(2)	No
1A1 Stationary Combustion, waste	N ₂ O	Tier 2	CS	Yes
1A1 Stationary Combustion, biomass	N ₂ O	Tier 2/Tier 1	CS / D(2) / D	Yes
1A2 Stationary Combustion, solid fuels	N ₂ O	Tier 1/Tier 3	D/PS	Yes
1A2 Stationary Combustion, liquid fuels	N ₂ O	Tier 2/Tier 1	D(2) / CS / D	Yes
1A2 Stationary Combustion, gaseous fuels	N ₂ O	Tier 3/Tier 2	CS / D(2)	No
1A2 Stationary Combustion, waste	N ₂ O	Tier 1	D	No
1A2 Stationary Combustion, biomass	N ₂ O	Tier 1/Tier 2	D / CS	No
1A4 Stationary Combustion, solid fuels	N ₂ O	Tier 1	D	No
1A4 Stationary Combustion, liquid fuels	N ₂ O	Tier 2/Tier 1	D(2) / CS / D	Yes
1A4 Stationary Combustion, gaseous fuels	N ₂ O	Tier 3/Tier 2	CS / D(2)	No
1A4 Stationary Combustion, waste	N ₂ O	Tier 1	D	No
1A4 Stationary Combustion, not residential wood and not residential/agricultural straw, biomass	N ₂ O	Tier 1/Tier 2	D / CS	No
1A4b_i Stationary Combustion, Residential wood combustion	N ₂ O	Tier 1	D	Yes
1A4b_i/1A4c_i Stationary Combustion, Residential and agricultural straw combustion	N ₂ O	Tier 1	D	No

1) D: IPCC (2006) default, tier 1. D(2): IPCC (2006) default, tier 2. CS: Country specific. PS: Plant specific. 2) KCA approach 1 or approach 2 for Denmark (excluding Greenland and Faroe Islands), including LULUCF, level 1990 or level 2020 or trend 1990-2020. 3) Only 5 % of the total coal consumption is included in the non-ETS category in 2020. 4) Only 7 % of the total residual oil consumption is included in the non-ETS category in 2020. 5) Tier 3 for less than 1 % of the gas oil consumption in 2020. 6) Tier 3 for less than 1 % of the LPG consumption in 2020.

Table 3.2.9 Emission data for key sources for which the estimated emissions are based on the tier 1 approach.

Source category	CO ₂ emission 1990, kton CO ₂ equivalent	CO ₂ emission 2020, kton CO ₂ equivalent	Key source (KCA approach)
1A Stationary combustion, Kerosene, CO ₂	368	3	Level 1990 (KCA 1), Trend (KCA 1)
1A4b_i Stationary Combustion, Residential wood combustion, N ₂ O	11	36	Level 2020 (KCA 2), Trend (KCA 2)
Key sources for which the estimated emissions are based on the tier 1 approach, total	378	39	

Large point sources

Large emission sources such as power plants, industrial plants and refineries are included as large point sources in the Danish emission database. Each point source may consist of more than one part, e.g. a power plant with several units. By registering the plants as point sources in the database, it is possible to use plant-specific emission factors.

In the inventory for the year 2020, 72 stationary combustion plants are specified as large point sources. Plant specific emission data⁹ are available from 64 of the plants. The point sources include:

- Power plants and decentralised CHP plants.
- Waste incineration plants.
- Large industrial combustion plants.
- Petroleum refining plants.

The criteria for selection of point sources are:

- All centralized power plants, including smaller units.
- All units with a capacity of above 25 MW_e.
- All district heating plants with an installed effect of 50 MW_{th} or above and significant fuel consumption.
- All waste incineration plants obligated to report environmental data annually according to Danish law (DEPA, 2010b; DEPA, 2015).
- Industrial plants,
 - With an installed effect of 50 MW_{th} or above and significant fuel consumption.
 - With a significant process related emission.

The fuel consumption of stationary combustion plants registered as large point sources in the 2020 inventory was 181 PJ. This corresponds to 51 % of the overall fuel consumption for stationary combustion.

A list of the large point sources for 2020 is provided in Annex 3A-5. The number of large point sources registered in the databases increased from 1990 to 2020. Aggregated fuel consumption rates for the large point sources are also shown in Annex 3A-5.

The emissions from a point source are based either on plant specific emission data or, if plant specific data are not available, on fuel consumption data and the general Danish emission factors.

⁹ For CO₂ or other pollutants.

The plant-specific emission data from the EU ETS data represent 60 % of the total CO₂ emission from stationary combustion. CO₂ emission factors are plant specific for the major power plants, refineries, offshore gas turbines, large municipal waste incineration plants and for cement production. Plant-specific emission data are obtained from CO₂ data reported under the EU Emission Trading Scheme (ETS). The EU ETS data are discussed below.

Emission measurement data for CH₄ and N₂O are applied for estimating emission factors but not implemented as plant specific data.

Annual environmental reports for the plants include a considerable number of emission data sets. In general, emission data from annual environmental reports are based on emission measurements, but some emissions have potentially been calculated from general emission factors.

If plant-specific emission factors are not available, emission factors for area sources are used.

Area sources

Fuels not combusted in large point sources are included as source category specific area sources in the emission database. Plants such as residential boilers, small district heating plants, small CHP plants and some industrial boilers are defined as area sources. Emissions from area sources are based on fuel consumption data and emission factors. Further information on emission factors is provided below in the chapter Emission factors.

Fuels used for non-energy purposes

The Danish national energy statistics includes three fuels used for non-energy purposes; bitumen, white spirit and lubricants. The total consumption for non-energy purposes is relatively low, e.g. 9.5 PJ in 2020. The use of fuels for non-energy purposes is included in the inventory in sector 2D Non-energy products from fuels and solvent use; see Chapter 4.5.3.

The non-energy use of fuels is included in the reference approach for Climate Convention reporting and appropriately corrected in line with the IPCC Guidelines (IPCC, 2006). The reference approach is included in Chapter 3.4.

Activity rates, fuel consumption

The fuel consumption rates are based on the official Danish energy statistics prepared by the Danish Energy Agency (DEA). DCE aggregates fuel consumption rates to SNAP categories. Some fuel types in the official Danish energy statistics are added to obtain a less detailed fuel aggregation level cf. Annex 3A-3. The calorific values on which the energy statistics are based are also enclosed in Annex 3A-3. The correspondence list between the energy statistics and SNAP categories is enclosed in Annex 4.

The fuel consumption of the CRF category Manufacturing industries and construction (corresponding to SNAP category 03) is disaggregated into industrial subsectors based on the DEA data set aggregated for the Eurostat reporting (DEA, 2021c). The fuel consumption data flow is shown in Figure 3.2.34.

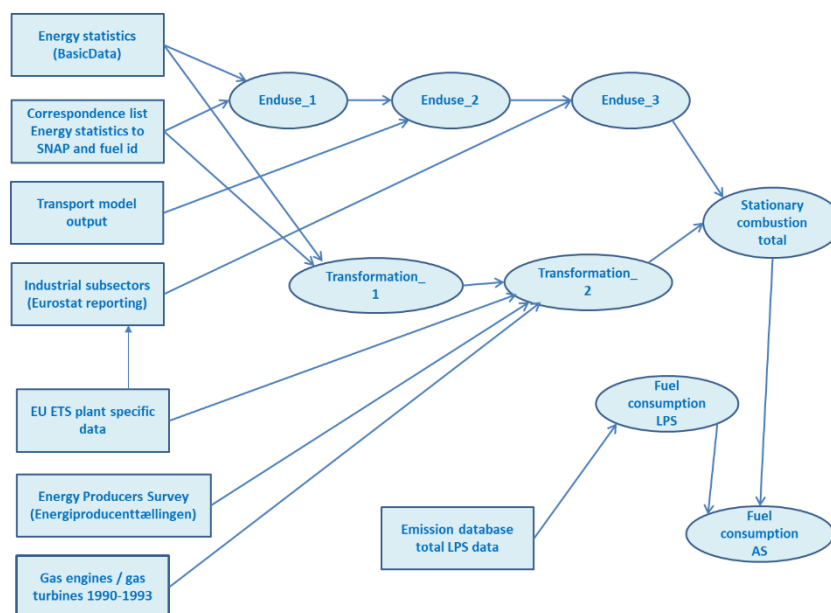

Figure 3.2.34 Fuel consumption data flow.

Both traded and non-traded fuels are included in the Danish energy statistics. Thus, for example, estimation of the annual consumption of non-traded wood is included.

Petroleum coke purchased abroad and combusted in Danish residential plants (border trade of 100-628 TJ in 1992-2018¹⁰) is not included in the Danish inventory. This is in agreement with the IPCC Guidelines (IPCC, 2006).

The fuel consumption data for large point sources refer to the EU Emission Trading Scheme (EU ETS) data for plants for which the CO₂ emission also refer to EU ETS, see page 129.

For all other large point sources, the fuel consumption refers to an annually updated DEA database; the Energy Producers Survey (DEA, 2021b). The Energy Producers Survey includes the fuel consumption of each district heating and power-producing plant, based on data reported by plant operators. The consistency between EU ETS reporting and the Energy Producers Survey database (DEA, 2021b) is checked by the DEA and discrepancies are corrected prior to the use in the emission inventory.

The fuel consumption of area sources is calculated as total fuel consumption in the energy statistics minus fuel consumption included in the emission inventory database in large point sources.

In Denmark, all waste incineration is utilised for heat and power production. Thus, incineration of waste is included as stationary combustion in the source category Fuel combustion (subcategories 1A1, 1A2 and 1A4).

Fuel consumption data are presented in Chapter 3.2.2.

Fuel consumption for 1A1c Oil and gas extraction

The consumption of natural gas reported in the EU ETS data are not in agreement with the energy statistics. This is because the energy statistics is based on the default net calorific value (NCV) for natural gas applied in Denmark

¹⁰ No border trade of petroleum coke in 2019-2020.

whereas the EU ETS data are based on fuel analysis of the natural gas applied offshore at each individual platform. The total consumption of natural gas in 1A1c Oil and gas extraction applied in the emission inventories is based on the EU ETS data.

The gas oil consumption offshore included in EU ETS data have been implemented in the emission inventory. In the energy statistics this consumption is included in domestic sea transport (Rusbjerg, 2021).

Fuel consumption for 1A1b Petroleum refining

The EU ETS data for fuel consumption reported by the two Danish refineries are not always in agreement with the energy statistics due to the use of default values for net calorific value (NCV) in the energy statistics. The EU ETS data are based on fuel analysis. Refinery gas is only applied in the two refineries. The total consumption of refinery gas applied in the emission inventories is based on the EU ETS data.

Upgraded biogas distributed in the natural gas grid

Biogas upgraded for distribution in the natural gas grid (bio natural gas) has been included as a separate fuel in the energy statistics and in the emission inventory. In this report biogas upgraded for distribution in the natural gas grid is called bio natural gas, but others might refer to this fuel as bio methane.

Biogas distributed in the town gas grid

The energy statistics includes a consumption of biogas for town gas production. This biogas is distributed in the town gas grid (117 TJ in 2020). This fuel consumption has been included in the fuel category town gas in the fuel consumption data of the energy statistics. In the emission inventory biogas distributed in the town gas grid have been included in the fuel category biogas.

Town gas

Town gas (the fossil part) has been included in the fuel category natural gas. The consumption of town gas in Denmark is very low, e.g. 0.6 PJ in 2020. In 1990, the town gas consumption was 1.6 PJ and the consumption has been steadily decreasing throughout the time series.

In Denmark, town gas is produced based on natural gas. The use of coal for town gas production ceased in the early 1980s.

An indicative composition of town gas in 2015 according to the largest supplier of town gas in Denmark is shown in Table 3.2.10 (KE, 2015).

Table 3.2.10 Composition of town gas currently used (KE, 2015).

Component	Town gas, % (mol.)
Methane	43.9
Ethane	2.9
Propane	1.1
Butane	0.5
Carbon dioxide	0.4
Nitrogen	40.5
Oxygen	10.7

The lower heating value of the town gas is 20.31 MJ per Nm³ and the CO₂ emission factor 56.1 kg per GJ. This is very close to the emission factor used for natural gas in 2015 (57.06 kg per GJ). According to the supplier, both the

composition and heating value will change during the year. It has not been possible to obtain a yearly average.

In earlier years, the composition of town gas was somewhat different. Table 3.2.11 shows data for town gas composition in 2000-2005. These data are constructed with the input from Københavns Energi (KE) (Copenhagen Energy) and Danish Gas Technology Centre (DGC), (Jeppesen, 2007; Kristensen, 2007). The data refer to three measurements performed several years apart, the first in 2000 and the latest in 2005.

Table 3.2.11 Composition of town gas, data from 2000-2005.

Component	Town gas, % (mol.)
Methane	22.3-27.8
Ethane	1.2-1.8
Propane	0.5-0.9
Butane	0.13-0.2
Higher hydrocarbons	0-0.6
Carbon dioxide	8-11.6
Nitrogen	15.6-20.9
Oxygen	2.3-3.2
Hydrogen	35.4-40.5
Carbon monoxide	2.6-2.8

The lower calorific value was been between 15.6 and 17.8 MJ per Nm³. The CO₂ emission factors - derived from the few available measurements - are in the range of 52-57 kg per GJ.

The Danish sectoral approach includes town gas as part of the fuel category natural gas and thus indirectly assumes the same CO₂ emission factor. This is a conservative approach ensuring that the CO₂ emissions are not underestimated.

Due to the scarce data available and the very low consumption of town gas compared to consumption of natural gas (< 0.5 %), the methodology will be applied unchanged in future inventories.

Biogas has been added to the town gas grid since 2014. This biogas distributed in the town gas grid is treated as a separate fuel in the emission inventories and thus not included in the data for town gas. Bio natural gas converted to town gas is included in the fuel category bio natural gas in the emission inventory.

Waste

All waste incineration in Denmark is utilised for heat and/or power production and thus included in the energy sector. The waste incinerated in Denmark for energy production consists of the waste fractions shown in Figure 3.2.35. In 2019¹¹, 3 % of the incinerated waste was hazardous waste.

¹¹ The complete waste statistics for 2020 was not available in January 2022.

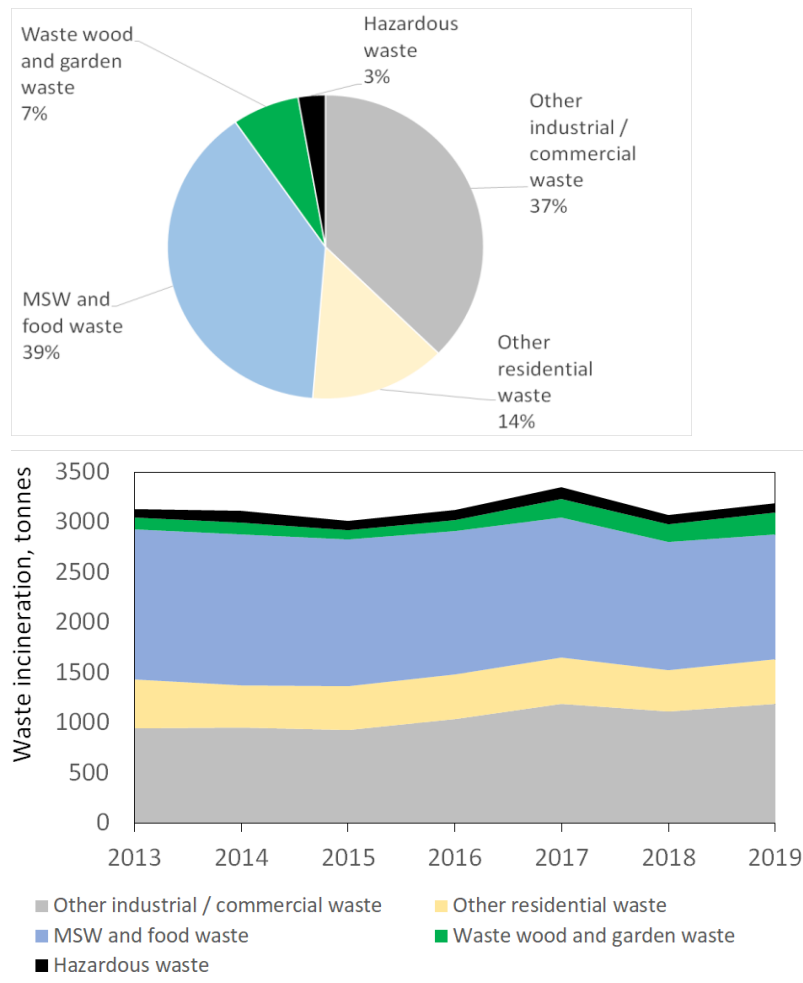

Figure 3.2.35 Waste fractions (weight) for incinerated waste in 2019 and the corresponding time series 2013-2019 (DEPA Waste statistics for 2019, 2021).

In connection to the project estimating an improved CO₂ emission factor for waste (Astrup et al., 2012), the fossil energy fraction was calculated. The fossil fraction was not measured or estimated as part of the project, but the flue gas measurements combined with data from Fellner & Rechberger (2010) indicated a fossil energy part of 45 %. The energy statistics also applies this fraction in the national statistics.

Biogas

Biogas includes landfill gas, sludge gas and manure/organic waste gas¹². The Danish energy statistics specifies production and consumption of each of the biogas types. In 2020, 67 % of the produced biogas was upgraded to bio natural gas. An increasing part of the biogas based on manure / organic waste is upgraded to bio natural gas.

Biogas upgraded for distribution in the natural gas grid reported as bio natural gas and is not included in the fuel category "biogas" in the rest of this report. This is also the case for bio gasification gas.

¹² Based on manure with addition of other organic waste.

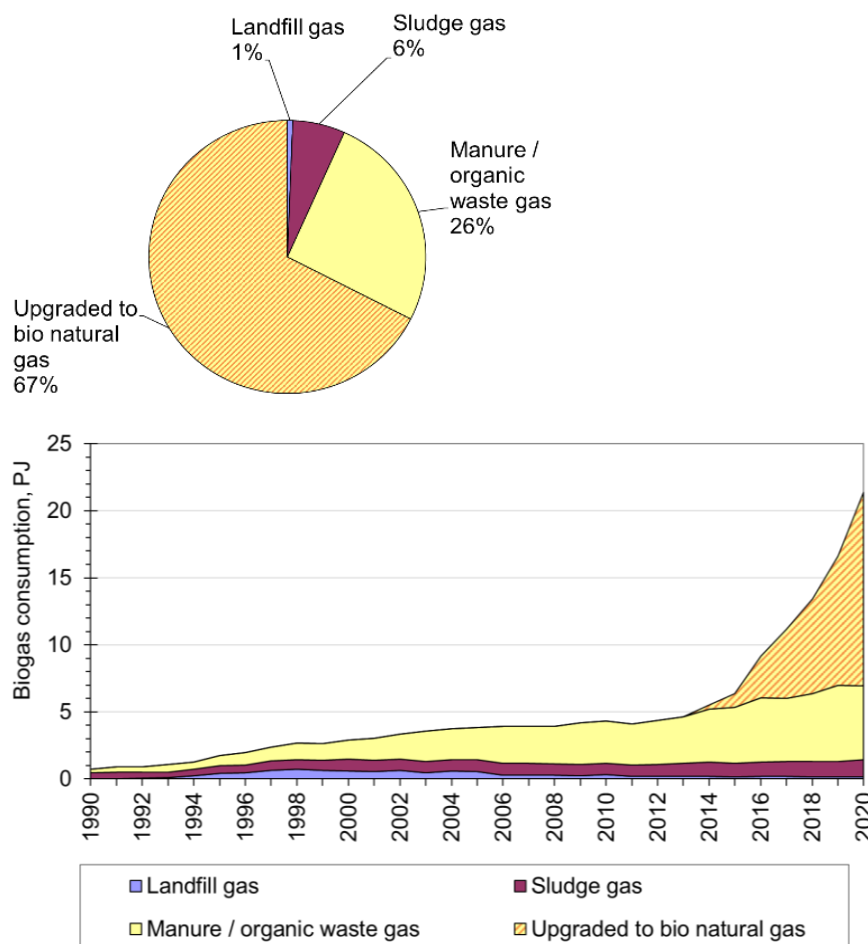

Figure 3.2.36 Biogas types (including bio natural gas) 2020 and the corresponding time series 1990-2020 (DEA, 2021e; DEA 2021a).

Emission factors

For each fuel and SNAP category (sector and e.g. type of plant), a set of general area source emission factors has been determined. The GHG emission factors are either nationally referenced or based on the IPCC Guidelines (2006). The emission factors for other pollutants are either nationally referenced or based on the EMEP/EEA Guidebook (EEA, 2019).

An overview of the type of CO₂ emission factor is shown in Table 3.2.19. A complete list, of emission factors including time series and references, is provided in Annex 3A-4.

EU ETS data for CO₂

The CO₂ emission factors for some large power plants and for combustion in the cement industry and refineries are plant specific and based on the reporting to the EU Emission Trading Scheme (EU ETS). In addition, emission factors for offshore gas turbines and refinery gas is based on EU ETS data. The EU ETS data have been applied for the years 2006 - 2020.

The EU ETS data are also applied for other source categories and are further discussed in Chapter 1.4.10.

The Danish emission inventory for stationary combustion only includes CO₂ emission data from plants using higher tier methods as defined in the EU decision (EU Commission, 2018), where the specific methods for determining

carbon contents, oxidation factor and calorific value are specified. The EU decision includes rules for measuring, reporting and verification.

Fuel consumption data from EU ETS are included for some additional plants and fuels, e.g. biomass fuels.

For each of the plants included with plant and fuel specific CO₂ emission factors in the Danish inventory all applied methodologies are specified in individual monitoring plans that are approved by Danish authorities (DEA) prior to the reporting of the emissions. The plant and fuel specific CO₂ emission factors included in the Danish inventory are all based on fuel quality measurements¹³, not default values from the Danish UNFCCC reporting. All fuel analyses are performed according to ISO 17025.

DCE performs QC checks on the reported emission data, see Chapter 1.4.10.

EU ETS data presentation

The EU ETS data include plant specific emission factors for coal, residual oil, gas oil, natural gas, refinery gas, petroleum coke, coke oven coke and fossil waste. The EU ETS data accounted for 57 % of the CO₂ emission from stationary combustion in 2020.

EU ETS data for coal

EU ETS data for 2020 were available from 14 coal fired plant (or units). The plant specific information accounts for 96 % of the Danish coal consumption and 24 % of the total fossil CO₂ emission from stationary combustion plants.

Data from 13 of the 14 plants have been applied for estimating an average CO₂ emission factor for coal¹⁴. The average CO₂ emission factor for coal for these 13 units was 94.20 kg per GJ (Table 3.2.12). The plants all apply bituminous coal.

Table 3.2.12 EU ETS data for 13 coal fired plants, 2020.

	Average	Min	Max
Heating value, GJ per tonne	24.2	23.2	29.8
CO ₂ implied emission factor, kg per GJ ¹⁾	94.20	90.54	96.34
Oxidation factor	0.995	0.979	1.000

1) Including oxidation factor.

¹³ Applying specific methods defined in the EU decision.

¹⁴ Fuel consumption of the 13 plants adds up to more than 99.9% of the fuel consumption of the 14 plants. One plant is not considered representative for the coal consumption in Denmark.

Table 3.2.13 CO₂ implied emission factor time series for coal fired plants based on EU ETS data.

Year	CO ₂ implied emission factor, kg per GJ ¹⁾
2006	94.4
2007	94.3
2008	94.0
2009	93.6
2010	93.6
2011	94.7
2012	94.25
2013	93.95
2014	94.17
2015	94.46
2016	94.95
2017	94.37
2018	94.04
2019	94.13
2020	94.20

1) Including oxidation factor.

EU ETS data for residual oil

EU ETS data for 2020 based on higher tier methodologies were available from 9 plants (or units) combusting residual oil. The EU ETS data accounts for 93 % of the residual oil consumption in stationary combustion.

Data from 8 of the 9 plants have been applied for estimating an average CO₂ emission factor for residual oil¹⁵. Aggregated data and time series are shown in Table 3.2.14 and Table 3.2.15.

Table 3.2.14 EU ETS data for 8 plants combusting residual oil.

	Average	Min	Max
Heating value, GJ per tonne	40.7	40.6	40.8
CO ₂ implied emission factor, kg per GJ	79.03	78.53	80.40
Oxidation factor	1.000	1.000	1.000

Table 3.2.15 CO₂ implied emission factor time series for residual oil fired power plant units based on EU ETS data.

Year	CO ₂ implied emission factor, kg per GJ ¹⁾
2006	78.2
2007	78.1
2008	78.5
2009	78.9
2010	79.2
2011	79.25
2012	79.21
2013	79.28
2014	79.49
2015	79.17
2016	79.29
2017	79.19
2018	79.42
2019	79.32
2020	79.03

1) Including oxidation factor.

EU ETS data for gas oil

EU ETS data for 2020 based on higher tier methodologies were included from only one plant combusting gas oil. Emission factor average values are shown

¹⁵ Fuel consumption of the 8 plants adds up to 74% of the fuel consumption of the 9 plants. The remaining plant is not considered representative for the residual oil consumption in Denmark.

in Table 3.2.16. The 2019 and 2020 emission factors are not included because data are only available from one plant.

Table 3.2.16 CO₂ implied emission factor time series for gas oil based on EU ETS data.

Year	CO ₂ implied emission factor, kg per GJ ¹⁾
2006	75.1
2007	74.9
2008	73.7
2009	75.1
2010	74.8
2011	74.7
2012	73.9
2013	72.7
2014	74.2
2015	73.8
2016	74.4
2017	74.7
2018	74.2
2019	-
2020	-

1) Including oxidation factor. The 2019-2020 value are not shown because data were only available from one plant.

EU ETS data for waste

EU ETS data for 2020 based on higher tier methodologies were included from 18 waste incineration plants (or units). The EU ETS data for waste incineration are based on emission measurements. The average emission factor value for 2020 is 42.6 kg per GJ. The emission factors are in the interval 33.6 kg per GJ to 55.8 kg per GJ. The EU ETS data accounts for 75 % of the incinerated waste.

Table 3.2.17 EU ETS data for waste incineration.

	Average	Min	Max
Heating value, GJ per tonne	10.7	10.6	13.0
CO ₂ implied emission factor, kg per GJ	42.6	33.6	55.8
Oxidation factor	1.000	1.000	1.000

Table 3.2.18 CO₂ implied emission factor time series for waste incineration.

Year	CO ₂ implied emission factor, kg per GJ
2013	43.0
2014	40.8
2015	43.3
2016	43.0
2017	41.4
2018	43.5
2019	42.5
2020	42.6

EU ETS data for petroleum coke, coke oven coke, industrial waste and natural gas

The implemented EU ETS data set also includes CO₂ emission factors for industrial waste, petroleum coke and coke oven coke. The industrial plants with additional EU ETS data include cement industry, sugar production, glass wool production, lime production, and vegetable oil production.

EU ETS data for natural gas applied in offshore gas turbines

EU ETS data have been applied to estimate an average CO₂ emission factor for natural gas combusted in offshore gas turbines, see page 139.

EU ETS data for refinery gas

EU ETS data are also applied for the two refineries in Denmark. The emission factor for refinery gas is based on EU ETS data, see page 138.

CO₂ emission factors

The CO₂ emission factors that are not included in EU ETS data or that are included but based on lower tier methodologies are not plant specific in the Danish inventory. The emission factors that are not plant specific accounts for 43 % of the fossil CO₂ emission.

The CO₂ emission factors applied for 2020 are presented in Table 3.2.19. Time series have been estimated for:

- Coal
- Residual oil
- Refinery gas
- Natural gas applied in offshore gas turbines
- Natural gas, other
- Waste, fossil part
- Industrial waste, biomass part

For all other fuels, the same emission factor has been applied for 1990-2020.

In the reporting to the UNFCCC, the CO₂ emission is aggregated to six fuel types: solid fuels, liquid fuels, gaseous fuels, other fossil fuels, peat, and biomass. Peat is not combusted in Denmark. The correspondence list between the DCE fuel categories and the IPCC fuel categories is also provided in Table 3.2.19.

Only emissions from fossil fuels are included in the total national CO₂ emission. The biomass emission factors are also included in the table, because emissions from biomass are reported to the UNFCCC as a memo item.

The CO₂ emission from incineration of waste (42.5 + 63.3 kg per GJ) is divided into two parts: The emission from combustion of the fossil content of the waste, which is included in the national total, and the emission from combustion of the biomass part, which is reported as a memo item. In the CRF, the fuel consumption and emissions from the fossil content of the waste is reported in the fuel category Other fossil fuels.

Table 3.2.19 CO₂ emission factors, 2020.

Fuel	Emission factor, kg per GJ		Reference type	IPCC fuel category
	Biomass	Fossil fuel		
Coal		94.20 ¹⁾	Country specific	Solid
Brown coal briquettes		97.5	IPCC (2006)	Solid
Coke oven coke		107 ³⁾	IPCC (2006)	Solid
Other solid fossil fuels ⁶⁾		118 ¹⁾	Country specific	Solid
Fly ash fossil (from coal)		94.20	Country specific	Solid
Petroleum coke		93 ³⁾	Country-specific	Liquid
Residual oil		79.03 ¹⁾	Country-specific	Liquid
Gas oil		74.1 ¹⁾	Country-specific	Liquid
Kerosene		71.9	IPCC (2006)	Liquid
Orimulsion		80 ²⁾	Country-specific	Liquid
LPG		64.8	Country-specific	Liquid
Refinery gas		56.813	Country-specific	Liquid
Natural gas, offshore gas turbines		57.456	Country-specific	Gas
Natural gas, other		55.52	Country-specific	Gas
Waste	63.3 ³⁾⁴⁾	+ 42.5 ¹⁾³⁾⁴⁾	Country-specific	Biomass and Other fuels
Straw	100		IPCC (2006)	Biomass
Wood	112		IPCC (2006)	Biomass
Wood pellets	112		IPCC (2006)	Biomass
Bio oil	70.8		IPCC (2006)	Biomass
Biogas	84.1		Country-specific	Biomass
Biomass gasification gas	142.9 ⁵⁾		Country-specific	Biomass
Bio natural gas	55.55		Country-specific	Biomass

1) Plant specific data from EU ETS incorporated for individual plants.

2) Not applied in 2020. Orimulsion was applied in Denmark in 1995 – 2004.

3) Plant specific data from EU ETS incorporated for cement industry and sugar, lime and mineral wool production.

4) The emission factor for waste is (42.5+63.3) kg CO₂ per GJ waste. The fuel consumption and the CO₂ emission have been disaggregated to the two IPCC fuel categories Biomass and Other fossil fuels in CRF. The corresponding fossil CO₂ emission factor for Other fuels is 94.44 kg CO₂ per GJ fossil waste and 115 kg biomass CO₂ per GJ biomass waste.

5) Includes a high content of CO₂ in the gas.

6) Anodic carbon. Not applied in Denmark in 2020.

Coal

As mentioned above, EU ETS data have been utilised for the years 2006 - 2020 in the emission inventory. The emission factor for coal is the implied emission factor for plants that report EU ETS data that are based on fuel analysis. Data for industrial plants have been included. In 2020, the implied emission factor (including oxidation factor) was 94.20 kg per GJ. The implied emission factor values were between 90.54 and 96.34 kg per GJ.

The emission factors for coal in the years 2006-2020 refer to the implied emission factors of the EU ETS data estimated for each year. For the years 1990-2005, the emission factor for coal (94 kg/GJ) refers to the average IEF for 2006-2010.

Time series for net calorific value (NCV) of coal are available in the Danish energy statistics. NCV for Electricity plant coal fluctuates in the interval 23.17-29.8 GJ per tonne.

The correlation between NCV and CO₂ IEF (including the oxidation factor) in the EU ETS data (2006-2009) have been analysed and the results are shown in Annex 3A-9. However, a significant correlation between NCV and IEF have not been found in the dataset and thus an emission factor time series based on the NCV time series was not relevant. In addition, the correlation of NCV and CO₂ emission factors has been analysed. This analysis is also shown in Annex

3A-9. As expected, the correlation was better in this dataset, but still insufficient for estimating a time series for the CO₂ emission factor based on the NCV time series. All coal applied in Denmark is bituminous coal (DEA, 2021c) and within the range of coal qualities applied in the plants reporting data to EU ETS a correlation could not be documented.

In 2020, the CO₂ emission from coal consumption was based on the emission factor (94.20 kg per GJ) for 4.4% of the coal consumption. The remaining 95.6 % was covered by EU ETS data.

Time series for the CO₂ emission factor are shown in Table 3.2.20.

Table 3.2.20 CO₂ emission factor time series for coal.

Year	CO ₂ emission factor kg per GJ
1990-2005	94.0
2006	94.4
2007	94.3
2008	94.0
2009	93.6
2010	93.6
2011	93.73
2012	94.25
2013	93.95
2014	94.17
2015	94.46
2016	94.95
2017	94.37
2018	94.04
2019	94.13
2020	94.20

Brown coal briquettes

The emission factor for brown coal briquettes, 97.5 kg per GJ refers to the IPCC Guidelines, 2006 (IPCC, 2006). The oxidation factor has been assumed equal to 1. The same emission factor has been applied for 1990-2020.

Coke oven coke

The emission factor for coke oven coke, 107 kg per GJ, refers to the IPCC Guidelines 2006 (IPCC, 2006). The oxidation factor has been assumed equal to 1. The same emission factor has been applied for 1990-2020.

Other solid fossil fuels (Anodic carbon)

Anodic carbon was not applied in 2020. Anodic carbon has been applied in Denmark in 2009-2013 in two mineral wool production units. The emission factor 118 kg per GJ refer to EU ETS data from one of the plants in 2012.

The emission factor is not applied because plant specific data are available from the EU ETS dataset.

Fly ash fossil (from coal)

Fly ash from coal combustion is applied in some power plants. The emission factor has been assumed equal to the emission factor for coal.

Petroleum coke

The emission factor 93 kg per GJ is based on EU ETS data for 2006-2010. The data includes one power plant and the cement production plant.

Plant specific EU ETS data have been utilised for the cement production for the years 2006 - 2020.

Residual oil

The emission factor for residual oil is based on EU ETS data.

EU ETS data have been utilised for the 2006 - 2020 emission inventories. In 2020, the implied emission factor (including oxidation factor) for the plants combusting residual oil was 79.03 kg per GJ. The implied emission factor values were between 78.53 and 80.40 kg per GJ.

The emission factors for residual oil in the years 2006-2020 refer to the implied emission factors of the EU ETS data estimated for each year. For the years 1990-2005, the emission factor for residual oil refers to the average IEF for 2006-2010.

In 2020, 7 % of the CO₂ emission from residual oil consumption was based on the emission factor, whereas 93 % of the residual oil consumption was covered by EU ETS data.

Time series for the CO₂ emission factor are shown in Table 3.2.21.

Table 3.2.21 CO₂ emission factor time series for residual oil.

Year	CO ₂ emission factor kg per GJ
1990-2005	78.7
2006	78.6
2007	78.5
2008	78.5
2009	78.9
2010	79.2
2011	79.25
2012	79.21
2013	79.28
2014	79.49
2015	79.17
2016	79.29
2017	79.19
2018	79.42
2019	79.32
2020	79.03

Gas oil

The emission factor for gas oil, 74.1 kg per GJ, is based on EU ETS data for the years 2008-2016. The emission factor is consistent with the IPCC default emission factor for gas oil (74.1 kg per GJ). The same emission factor has been applied for 1990-2020.

Plant specific EU ETS data have been utilised for a few plants each year in the 2006 - 2020 emission inventories. In 2020, EU ETS data were only available from one plant representing less than 1 % of the consumption of gas oil.

Kerosene

The emission factor for kerosene, 71.9 kg per GJ, refers to IPCC Guidelines (IPCC, 2006). The same emission factor has been applied for 1990-2020.

Orimulsion

The emission factor for orimulsion, 80 kg per GJ, refers to the Danish Energy Agency (DEA, 2021a). The IPCC default emission factor is almost the same: 80.7 kg per GJ assuming full oxidation. The CO₂ emission factor has been confirmed by the only major power plant operator using orimulsion (Andersen, 1996). The same emission factor has been applied for all years. Orimulsion was used in Denmark in 1995-2004.

LPG

The emission factor for LPG have been revised this year. The former CO₂ emission factor for LPG, 63.1 kg/GJ, referred to IPCC Guidelines (2006). According to the latest Key Category Analysis, combustion of LPG is a Key Category¹⁶ and a tier 2 methodology should be applied.

Emission factor 2019 onwards

According to Danish legislation the butane content of LPG is below 7.5 % and the content of higher hydrocarbons (C5+) below 0.2 % (Danish Safety Technology Authority, 2018; Danish Safety Authority, 2012). Thus, since 2012 the minimum content of propane is 92.3 %.

According to Drivkraft Danmark, the LPG delivered to Denmark has a propane content of minimum 93 % in recent years (Rosvall, 2021). Bio LPG sold in Denmark is based on certificates from other countries (Rosvall, 2021) and thus all LPG applied in Denmark is considered fossil.

The CO₂ emission factor 64.8 kg/GJ (based on Rosvall, 2021) will be applied for 2019 onwards. These data are based on the gas composition from Drivkraft Danmark, 93 % propane and 7 % butane (Rosvall, 2021).

The 93 % propane on which the estimate is based is a minimum, but the emission factor for 100 % propane is 64.6 kg/GJ and thus the emission factor is in the interval 64.6-64.8 kg/GJ.

Different mixtures of propane and butane are considered and the estimated CO₂ emission factors and calorific values for each of them are shown in Table 3.2.22. For all the considered compositions, the CO₂ emission factors are higher than the current emission factor (63.1 kg/GJ). The emission factor in IPCC Guidelines (2006) is lower than the emission factors for both propane and butane (see Table 3.2.22 and Juhrich, 2016). The butane content is considered 1/3 i-Butane and 2/3 n-butane referring to Kjellander (2021).

In Germany, Sweden, Norway and the Netherlands the applied emission factor for 2019 are 66.33 kg/GJ (NIR Germany, 2021)¹⁷, 65.1 kg/GJ (NIR Sweden, 2021), 65.08 kg/GJ (NIR Norway, 2021), and 66.7 kg/GJ (NIR Netherlands, 2021) respectively.

Time series

In 1990-2005, mixed gases with higher butane content was also sold in Denmark (Rosvall, 2021; Kjellander, 2021; Tønder, 2021). The applied mixed gases were primarily applied for vehicles (Kjellander, 2021; Tønder, 2021) and the mixture proportions were 30%/70% in the summer and 50%/50% in the winter (Rosvall, 2021). The use of mixed gases is included in the fuel category LPG

¹⁶ KCA tier 1, level 2019.

¹⁷ 64.0-66.6 kg/GJ (Juhrich, 2016).

in the energy statistics. However, the use of mixed gases was low. The average LPG composition including mixed gases have been estimated to be 90 % propane and 10 % butane in 1990 (Rosvall, 2021; Kjellander, 2021). In 2005-2017, the minimum propane content was 95 % (Tønder, 2021).

The estimated CO₂ emission factors for different butane shares of LPG is shown in Table 3.2.22. The emission factors for both the 1990 and the 2019 composition is 64.8 kg/GJ. The CO₂ emission factor for 2005-2017 is 64.7 kg/GJ. Due to the marginal difference and the uncertainty, DCE has decided to use the CO₂ emission factor 64.8 kg/GJ for all years.

Table 3.2.22 Estimated LCV and CO₂ emission factors for different LPG compositions.

	Propane	Butane ¹⁸	LCV, MJ/kg	CO ₂ emission factor, kg/GJ
LPG according to legislation for LPG gas quality ¹⁹ (Danish Safety Technology Authority, 2018)	92.5 %	<7.5 %	46.3	64.8
LPG according to Drivkraft Danmark (Rosvall, 2021)	93 %	7 %	46.3	64.8
LPG according to specification 2005-2017 (Tønder, 2021)	95 %	5 %	46.3	64.7
LPG applied in 1990, (Rosvall, 2021; Kjellander, 2021)	90 %	10 %	46.2	64.8
100 % propane	100 %	0%	46.3	64.6
100 % butane (1/3 i-Butane)	0 %	100 %	45.7	66.3
100 % i-Butane	0 %	100 %	45.6	66.5
100 % n-Butane	0 %	100 %	45.7	66.2

Refinery gas

The emission factor applied for refinery gas refers to EU ETS data for the two refineries in operation in Denmark. Since 2006, implied emission factors for Denmark have been estimated annually based on the EU ETS data. The average implied emission factor for 2006-2009 (57.6 kg per GJ) have been applied for the years 1990-2005. This emission factor is consistent with the emission factor stated in the IPCC Guidelines (IPCC, 2006). The time series is shown in Table 3.2.23.

Table 3.2.23 CO₂ emission factors for refinery gas, time series.

Year	CO ₂ emission factor, kg per GJ
1990-2005	57.6
2006	57.812
2007	57.848
2008	57.948
2009	56.817
2010	57.134
2011	57.861
2012	58.108
2013	58.274
2014	57.620
2015	57.508
2016	57.335
2017	57.109
2018	56.144
2019	56.452
2020	56.813

¹⁸ Assumed 2/3 n-Butane and 1/3 i-butane (Kjellander, 2021).

¹⁹ <0.2 % higher hydrocarbons (C5+) have not been taken into account.

Natural gas, offshore gas turbines

EU ETS data for the fuel consumption and CO₂ emission for offshore gas turbines are available for the years 2006-2020. Based on data for each oilfield, implied emission factors have been estimated for 2006-2020. The average value for 2006-2009 has been applied for the years 1990-2005. The time series is shown in Table 3.2.24.

Table 3.2.24 CO₂ emission factors for offshore gas turbines, time series.

Year	CO ₂ emission factor, kg per GJ
1990-2005	57.469
2006	57.879
2007	57.784
2008	56.959
2009	57.254
2010	57.314
2011	57.379
2012	57.423
2013	57.295
2014	57.381
2015	57.615
2016	57.704
2017	57.628
2018	57.639
2019	57.588
2020	57.456

Natural gas, other source categories

The fuel category Natural gas refer to fossil natural gas. In recent years, bio natural gas²⁰ has also been distributed in the gas grid in Denmark. Natural gas (fossil) and bio natural gas is considered two separate fuels in the emission inventory.

The emission factor for natural gas is estimated by the Danish gas transmission company, Energinet.dk²¹. The calculation is based on gas analysis carried out daily by Energinet.dk at Egtved.

The offshore gas platform Tyra in the North Sea has for decades been the major gas supplier for Denmark. The platform is shut down for redevelopment from September 2019 to summer 2023 (Energinet.dk, 2021). Thus, the import of natural gas is high, and the production low compared to the years before 2019. This cause a change of gas quality and CO₂ emission factor in 2020. In 2020, the natural gas production was 50 PJ, the import was 93 PJ, the export 60 PJ.

Before 2010, only natural gas from the Danish gas fields was utilised in Denmark. Energinet.dk have stated that the difference between the emission factor for 2011 based on measurements at Egtved and the average value at Froeslev very close to the border differed less than 0.3 % for 2011 (Bruun, 2012).

Energinet.dk and the Danish Gas Technology Centre have calculated emission factors for 2000-2020. The emission factor applied for 1990-1999 refers to Fenhann & Kilde (1994). This emission factor was confirmed by the two major

²⁰ Bio methane.

²¹ Former Gastra and before that part of DONG. Historical data refer to these companies.

power plant operators in 1996 (Christiansen, 1996 and Andersen, 1996). The time series for the CO₂ emission factor is provided in Table 3.2.25.

Table 3.2.25 CO₂ emission factor time series for natural gas.

Year	CO ₂ emission factor, kg per GJ
1990-1999	56.9
2000	57.1
2001	57.25
2002	57.28
2003	57.19
2004	57.12
2005	56.96
2006	56.78
2007	56.78
2008	56.77
2009	56.69
2010	56.74
2011	56.97
2012	57.03
2013	56.79
2014	56.95
2015	57.06
2016	57.01
2017	57.00
2018	56.89
2019	56.54
2020	55.52 ¹⁾

1) The decrease of the CO₂ emission factor in 2020 is caused by shut down of the off-shore gas platform Tyra in the North Sea. The platform is shut down for redevelopment from September 2019 to summer 2023 (Energinet.dk, 2021). The gas quality of import gas differs from the gas quality from Tyra.

Waste

The CO₂ emission from incineration of waste is divided into two parts: The emission from combustion of the fossil content of the waste, which is included in the national total (42.5 kg fossil CO₂ per GJ waste), and the emission from combustion of the rest of the waste – the biomass part, which is reported as a memo item (63.3 kg biomass CO₂ per GJ waste).

The fossil CO₂ emission factor is based on EU ETS data for 2013-2016. The annual average emission factors for the plants that applied plant specific data are shown in Table 3.2.26 below. The emission factor applied for 2013-2020 is the average value for 2013-2016, 42.5 kg fossil CO₂ per GJ waste. The emission factor for the fossil fraction corresponds to 94.44 kg fossil CO₂ per GJ fossil waste. The emission factor for the biomass fraction corresponds to 115 kg biomass CO₂ per GJ biomass waste.

As mentioned, plant specific EU ETS data have been reported by CHP plants incinerating waste for 2013-2020. In the inventory for 2020, plant specific emission factors have been implemented for 18 plants or units. In 2020, the average fossil CO₂ emission factor for 17 plants (the cement production plant not included) was 42.6 kg fossil CO₂ per GJ total waste. The emission factors vary between plants – 33.6 kg per GJ to 55.8 kg per GJ. The 18 plants reporting data to EU ETS represent 75 % of the incinerated waste.

The CO₂ emission data included from EU ETS are based on flue gas emission measurements. The content of biogenic and fossil carbon is based on meas-

urements. Two different methods are applied: a radiocarbon dating (^{14}C analysis) of CO_2 sampled from the flue gas, and an approved mass and energy balance calculation.

The emission factor for 1990-2010 is based on the project, *Biogenic carbon in Danish combustible waste* that included emission measurements from five Danish waste incineration plants (Astrup et al., 2012). The average of the fossil emission factors for waste was estimated to be 37 kg per GJ waste and the interval for the five plants was 25 – 51 kg per GJ. The five plants represented 44 % of the incinerated waste in 2010. The emission factor 37 kg per GJ waste corresponds to 82.22 kg per GJ fossil waste.

The emission factor for biogenic CO_2 from waste refers to Astrup et al. (2012). The average value for five plants is 63.3 kg biogenic CO_2 per GJ total waste. This emission factor has been applied all years. The emission factor corresponds to 115 kg biogenic CO_2 per GJ biogenic waste.

The time series for the fossil CO_2 emission factor is shown in Table 3.2.27.

Table 3.2.26 Average fossil CO_2 emission factors based on EU ETS data for waste.

Year	Fossil CO_2 emission factor, kg fossil CO_2 per GJ waste (total)
2013	43.0
2014	40.8
2015	43.3
2016	43.0
2017	41.4
2018	43.5
2019	42.5
2020	42.6
Average 2013-2016	42.5

Table 3.2.27 Time series for the fossil CO_2 emission factor for waste.

Year	CO_2 emission factor, kg per GJ
1990-2010	37.0
2011	37.5
2012	40.0
2013-2020	42.5

Data from the waste statistics have been analysed with the purpose to improve the time series of the fossil waste emission factor. However, the data analysis has shown that is difficult to relate the available waste fraction data and the measured fossil CO_2 emission. Thus, currently it is not possible to estimate an improved time series for the emission factor for the years 1990-2012.

Industrial waste

The fuel category industrial waste is only applied for one plant; the cement production plant Aalborg Portland. The waste applied in this plant differ considerably from waste applied in waste incineration plants. Plant specific CO_2 emission data is available from EU ETS since 2006, and thus the inventory is based on these data.

The waste applied by Aalborg Portland includes several industrial waste products but no municipal waste. The fossil content of each of the applied waste fuels is defined in the EU ETS data.

Plant specific data are considered confidential, and thus the default fossil CO₂ emission factor is equal to the CO₂ emission factor for waste. However, only the plant specific emission factor is applied.

Wood

The emission factor for wood, 112 kg per GJ refers IPCC (2006). The same emission factor has been applied for 1990-2020.

Straw

The emission factor for wood, 100 kg per GJ refers IPCC (2006) for other primary solid biomass. The same emission factor has been applied for 1990-2020.

Bio oil

The emission factor, 70.8 kg per GJ refers to the IPCC (2006). The consumption of bio oil is below 2 PJ.

Biogas

In Denmark, three different types of biogas are applied: Manure/organic waste-based biogas, landfill-based biogas and wastewater treatment biogas (sludge gas). Manure / organic waste-based biogas represent 93 % of the biogas production, see page 128. Most of the biogas based on manure / organic waste is however upgraded to bio natural gas. The CO₂ emission factor for bio natural gas differs from the emission factor for biogas.

The emission factor for biogas 84.1 kg per GJ refer to Kristensen (2015a), and the emission factor is based on a biogas with 65 % (vol.) CH₄ and 35 % (vol.) CO₂. Danish Gas Technology Centre has stated that this is a typical manure-based biogas as utilised in stationary combustion plants (Kristensen, 2015a). The same emission factor has been applied for 1990-2020.

Biomass gasification gas

Biomass gasification gas applied in Denmark is based on wood. The gas composition is known for three different plants and the applied emission factor have been estimated by Danish Gas Technology Centre (Kristensen, 2010) based on the gas composition measured on the plant with the highest consumption.

The consumption of biomass gasification gas is below 2 PJ for all years.

Bio natural gas

Biogas upgraded for distribution in the natural gas grid is referred to as bio natural gas in this report. Other references might refer to this fuel as bio-methane or upgraded biogas. Bio natural gas has been applied in Denmark since 2014. The emission factor is based on the gas composition of bio natural gas: 98.5 % CH₄ and 1.5 % CO₂. These data refer to Danish Gas Technology Centre (Kristensen, 2015b).

CH₄ emission factors

The CH₄ emission factors applied for 2020 are presented in Table 3.2.28. In general, the same emission factors have been applied for 1990-2020. However,

time series have been estimated for both natural gas fuelled engines and biogas fuelled engines, residential wood combustion, natural gas fuelled gas turbines²² and waste incineration plants.

Emission factors for CHP plants < 25 MW_e refer to emission measurements carried out on Danish plants (Nielsen et al., 2010a; Nielsen & Illerup, 2003; Nielsen et al., 2008). The emission factors for residential wood combustion are based on technology dependent data.

Emission factors that are not nationally referenced all refer to the IPCC Guidelines (IPCC, 2006).

Gas engines combusting natural gas or biogas accounted for 52 % of the CH₄ emission from stationary combustion plants in 2020. The relatively high emission factor for gas engines is well documented and further discussed below.

²² A minor emission source.

Table 3.2.28 CH₄ emission factors, 2020.

Fuel group	Fuel	CRF source category	CRF source category	SNAP	Emission factor, g per GJ	Reference	
SOLID	Coal	1A1a	Public electricity and heat production	0101 0102	0.9	IPCC (2006), Tier 3, Table 2-6, Utility Boiler, Pulverised bituminous coal combustion, Wet bottom.	
		1A2 a-g	Industry	03	10	IPCC (2006), Tier 1, Table 2-3, Manufacturing industries.	
		1A4b i	Residential	0202	300	IPCC (2006), Tier 1, Table 2.5, Residential, Bituminous coal.	
		1A4c i	Agriculture/ Forestry	0203	10	IPCC (2006), Tier 1, Table 2-4, Commercial, coal. ¹⁾	
	BKB	1A4b i	Residential	0202	300	IPCC (2006), Tier 1, Table 2-5, Residential, brown coal briquettes	
	Coke oven coke	1A2 a-g	Industry	03	10	IPCC (2006), Tier 1, Table 2-4, Commercial, coke oven coke.	
		1A4b i	Residential	0202	300	IPCC (2006), Tier 1, Table 2-5, Residential, coke oven coke.	
	Anodic carbon	1A2 a-g	Industry	03	10	IPCC (2006), Tier 1, Table 2-3, Manufacturing industries.	
	Fossil fly ash	1A1a	Public electricity and heat production	0101	0.9	IPCC (2006), Tier 3, Table 2-6, Utility Boiler, Pulverised bituminous coal combustion, Wet bottom.	
	LIQUID	Petroleum coke	1A2 a-g	Industry	03	3	IPCC (2006), Tier 1, Table 2-3, Industry, petroleum coke.
			1A4a	Commercial/ Institutional	0201	10	IPCC (2006), Tier 1, Table 2-4, Commercial, Petroleum coke.
			1A4b	Residential	0202	10	IPCC (2006), Tier 1, Table 2-5, Residential / agricultural, Petroleum coke.
1A4c			Agriculture/ Forestry	0203	10	IPCC (2006), Tier 1, Table 2-5, Residential / agricultural, Petroleum coke.	
Residual oil		1A1a	Public electricity and heat production	010101	0.8	IPCC (2006), Tier 3, Table 2-6, Utility Boiler, Residual fuel oil.	
				010102 010103	1.3	Nielsen et al. (2010a)	
				010104	3	IPCC (2006), Tier 1, Table 2-2, Energy industries, residual oil.	
				010105	4	IPCC (2006), Tier 3, Table 2-6, Utility, Large diesel engines	
				010203	0.8	IPCC (2006), Tier 3, Table 2-6, Utility Boiler, Residual fuel oil.	
				010306	3	IPCC (2006), Tier 1, Table 2-2, Energy industries, residual fuel oil.	
		1A1b	Petroleum refining	010306	3	IPCC (2006), Tier 1, Table 2-2, Energy industries, residual fuel oil.	
		1A2 a-g	Industry	03	1.3	Nielsen et al. (2010a)	
				Engines	4	IPCC (2006), Tier 3, Table 2-6, Utility, Large diesel engines	
		1A4a	Commercial/ Institutional	0201	1.4	IPCC (2006), Tier 3, Table 2-10, Commercial, residual fuel oil boilers.	
		1A4b	Residential	0202	1.4	IPCC (2006), Tier 3, Table 2-9, Residential, residual fuel oil.	
		1A4c	Agriculture/ Forestry	0203	1.4	IPCC (2006), Tier 3, Table 2-10, Commercial, residual fuel oil boilers. ¹⁾	
Gas oil		1A1a	Public electricity and heat production	010101 010102 010103	0.9	IPCC (2006), Tier 3, Table 2-6, Utility, gas oil, boilers.	
				010104	3	IPCC (2006), Tier 1, Table 2-2, Energy industries, gas oil.	
				010105	24	Nielsen et al. (2010a)	
				010202 010203	0.9	IPCC (2006), Tier 3, Table 2-6, Utility, gas oil, boilers.	
				010306	3	IPCC (2006), Tier 1, Table 2-2, Energy industries, gas oil.	
				010500	0.9	IPCC (2006), Tier 3, Table 2-6, Utility, gas oil, boilers.	
		1A1b	Petroleum refining	010306	3	IPCC (2006), Tier 1, Table 2-2, Energy industries, gas oil.	
	1A1c	Oil and gas extraction	010500	0.9	IPCC (2006), Tier 3, Table 2-6, Utility, gas oil, boilers.		
	1A2 a-g	Industry	03	0.2	IPCC (2006), Tier 3, Table 2-7, Industry, gas oil, boilers.		
			Turbines Engines	3 24	IPCC (2006), Tier 1, Table 2-3, Industry, gas oil. Nielsen et al. (2010a)		

Fuel group	Fuel	CRF source category	CRF source category	SNAP	Emission factor, g per GJ	Reference		
	Kerosene	1A4a	Commercial/ Institutional	0201	0.7	IPCC (2006), Tier 3, Table 2-10, Commercial, gas oil.		
				020105	24	Nielsen et al. (2010a)		
		1A4b i	Residential	0202	0.7	IPCC (2006), Tier 3, Table 2.9, Residential, gas oil.		
				020204	24	Nielsen et al. (2010a)		
		1A4c	Agriculture/ Forestry	0203	0.7	IPCC (2006), Tier 3, Table 2-10, Commercial, gas oil ¹⁾ .		
				020304	24	Nielsen et al. (2010a)		
	LPG	1A2 a-g	Industry	03	3	IPCC (2006), Tier 1, Table 2-3, Industry, other kerosene.		
				0201	10	IPCC (2006), Tier 1, Table 2-4, Commercial, other kerosene.		
				0202	10	IPCC (2006), Tier 1, Table 2-5, Residential/agricultural, other kerosene.		
				0203	10	IPCC (2006), Tier 1, Table 2-5, Residential/agricultural, other kerosene.		
	Refinery gas	1A1a	Public electricity and heat production	0101	1	IPCC (2006), Tier 1, Table 2-2, Energy Industries, LPG.		
				0102	1	IPCC (2006), Tier 1, Table 2-2, Energy Industries, LPG.		
1A1b		Petroleum refining	0103	1	IPCC (2006), Tier 1, Table 2-2, Energy Industries, LPG.			
			03	1	IPCC (2006), Tier 1, Table 2-3, Industry, LPG			
1A4a		Commercial/ Institutional	0201	5	IPCC (2006), Tier 1, Table 2-4, Commercial, LPG.			
			0202	5	IPCC (2006), Tier 1, Table 2-5, Residential / agricultural, LPG.			
1A4c i	Agriculture/ Forestry	0203	5	IPCC (2006), Tier 1, Table 2-5, Residential / agricultural, LPG.				
		010304	1.7	Assumed equal to natural gas fuelled gas turbines. Nielsen et al. (2010a)				
GAS	Natural gas	1A1a	Public electricity and heat production	010101	1	IPCC (2006), Tier 3, Table 2-6, Utility, natural gas, boilers.		
				010102				
				010103				
				010104	1.7	Nielsen et al. (2010a)		
				010105	481	Nielsen et al. (2010a)		
				010202	1	IPCC (2006), Tier 3, Table 2-6, Utility, natural gas, boilers.		
				010203				
				010306	1	Assumed equal to industrial boilers.		
				010503	1	Assumed equal to industrial boilers.		
				010504	1.7	Nielsen et al. (2010a)		
				1A2 a-g	Industry	Other	1	IPCC (2006), Tier 3, Table 2-7, Industry, natural gas boilers.
						Gas turbines	1.7	Nielsen et al. (2010a)
						Engines	481	Nielsen et al. (2010a)
				1A4a	Commercial/ Institutional	0201	1	IPCC (2006), Tier 3, Table 2-10, Commercial, natural gas boilers.
						020105	481	Nielsen et al. (2010a)
				1A4b i	Residential	0202	1	IPCC (2006), Tier 3, Table 2-9. Residential, natural gas boilers.
						020204	481	Nielsen et al. (2010a)
				1A4c i	Agriculture/ Forestry	0203	1	IPCC (2006), Tier 3, Table 2-10, Commercial, natural gas boilers ¹⁾ .
020304	481	Nielsen et al. (2010a)						
WASTE	Waste	1A1a	Public electricity and heat production	0101	0.34	Nielsen et al. (2010a)		
				0102				
				03	30	IPCC (2006), Tier 1, Table 2-3, Industry, municipal wastes.		
	Industrial waste	1A2f	Industry	0201	30	IPCC (2006), Tier 1, Table 2-3, Industry, municipal wastes ²⁾ .		
0316				30	IPCC (2006), Tier 1, Table 2-3, Industry, industrial wastes.			

Fuel group	Fuel	CRF source category	CRF source category	SNAP	Emission factor, g per GJ	Reference
BIO- MASS	Wood	1A1a	Public electricity and heat production	0101	3.1	Nielsen et al. (2010a)
				0102	11	IPCC (2006), Tier 3, Table 2-6, Utility boilers, wood
		1A2 a-g	Industry	03	11	IPCC (2006), Tier 3, Table 2-7, Industry, wood, boilers.
		1A4a	Commercial/ Institutional	0201	11	IPCC (2006), Tier 3, Table 2-10, Commercial, wood.
		1A4b i	Residential	0202	99.01	DCE estimate based on technology distribution, Nielsen et al. (2021) ³⁾
	1A4c i	Agriculture/ Forestry	0203	11	IPCC (2006), Tier 3, Table 2-10, Commercial, wood. ¹⁾	
	Straw	1A1a	Public electricity and heat production	0101	0.47	Nielsen et al. (2010a)
				0102	30	IPCC (2006), Tier 1, Table 2-2, Energy industries, other primary solid biomass
		1A4b i	Residential	0202	300	IPCC (2006), Tier 1, Table 2-5, Residential, other primary solid biomass.
		1A4c i	Agriculture/ Forestry	020300	300	IPCC (2006), Tier 1, Table 2-5, Agriculture, other primary solid biomass.
				020302	30	IPCC (2006), Tier 1, Table 2-2, Energy industries, other primary solid biomass (large agricultural plants considered equal to this plant category)
	Wood pellets	1A1a	Public electricity and heat production	0101	3.1	Nielsen et al. (2010a)
				0102	3	Paulrud et al. (2005)
		1A2 a-g	Industry	03	3	Paulrud et al. (2005)
		1A4a	Commercial/ Institutional	0201	3	Paulrud et al. (2005)
1A4b i		Residential	0202	3	Paulrud et al. (2005)	
1A4c i		Agriculture/ Forestry	0203	3	Paulrud et al. (2005)	
Bio oil	1A1a	Public electricity and heat production	010102	3	IPCC (2006), Tier 1, Table 2-2, Energy industries, biodiesels.	
			010105	24	Nielsen et al. (2010a) assumed same emission factor as for gas oil fuelled engines.	
			0102	3	IPCC (2006), Tier 1, Table 2-2, Energy industries, biodiesels.	
	1A2 a-g	Industry	03	3	IPCC (2006), Tier 1, Table 2-3, Industry, biodiesels.	
	1A4b i	Residential	030902	0.2	-	
			0202	10	IPCC (2006), Tier 1, Table 2-5, Residential, biodiesels.	
Biogas	1A1a	Public electricity and heat production	0101	1	IPCC (2006), Tier 1, Table 2-2, Energy industries, other biogas.	
			010105	434	Nielsen et al. (2010a)	
			0102	1	IPCC (2006), Tier 1, Table 2-2, Energy industries, other biogas.	
	1A2 a-g	Industry	03	1	IPCC (2006), Tier 1, Table 2-3, Industry, other biogas.	
			Engines	434	Nielsen et al. (2010a)	
	1A4a	Commercial/ Institutional	0201	5	IPCC (2006), Tier 1, Table 2-4, Commercial, other biogas.	
			020105	434	Nielsen et al. (2010a)	
	1A4b	Residential	0202	1	Assumed equal to natural gas.	
	1A4c i	Agriculture/ Forestry	0203	5	IPCC (2006), Tier 1, Table 2-5, Agriculture, other biogas.	
			020304	434	Nielsen et al. (2010a)	
Bio gasification gas	1A1a	Public electricity and heat production	010101	1	Assumed equal to biogas.	
			010105	13	Nielsen et al. (2010a)	
1A4a	Commercial/Institutional	020105	13	Nielsen et al. (2010a)		
Bio natural gas	1A1a	Public electricity and heat production	0101	1	Assumed equal to natural gas.	
			0102			

Fuel group	Fuel	CRF source category	CRF source category	SNAP	Emission factor, g per GJ	Reference
		1A2 a-g	Industry	03	1	Assumed equal to natural gas.
		1A4a	Commercial/ Institutional	0201	1	Assumed equal to natural gas.
		1A4b	Residential	0202	1	Assumed equal to natural gas.
		1A4c	Agriculture/ Forestry	0203	1	Assumed equal to natural gas.

- 1) Assumed same emission factors as for commercial plants. Plant capacity and technology are similar for Danish plants.
- 2) Assumed same emission factor as for industrial plants. Plant capacity and technology is similar to industrial plants rather than to residential plants.
- 3) Aggregated emission factor based on the technology distribution in the sector (Nielsen et al., 2021) and technology specific emission factors that refer to Paulrud et al. (2005), Johansson et al. (2004) and Olsson & Kjällstrand (2005). The emission factor is within the IPCC (2006) interval for residential wood combustion (100-900 g per GJ).

CHP plants

A considerable part of the electricity production in Denmark is based on decentralised CHP plants, and well-documented emission factors for these plants are, therefore, of importance. In a project carried out for the electricity transmission company, Energinet.dk, emission factors for CHP plants <25MW_e have been estimated. The work was reported in 2010 (Nielsen et al., 2010a).

The work included waste incineration plants, CHP plants combusting wood and straw, natural gas and biogas-fuelled (reciprocating) engines, natural gas fuelled gas turbines, gas oil fuelled engines, gas oil fuelled gas turbines, steam turbines fuelled by residual oil and engines fuelled by biomass gasification gas. CH₄ emission factors for these plants all refer to Nielsen et al. (2010a). The estimated emission factors were based on existing emission measurements as well as on emission measurements carried out within the project. The number of emission data sets was comprehensive. Emission factors for subgroups of each plant type were estimated, e.g. the CH₄ emission factors for different gas engine types were determined.

Time series for the CH₄ emission factors are based on a similar project estimating emission factors for year 2000 (Nielsen & Illerup, 2003).

Natural gas, gas engines

The emission factor for natural gas engines refers to the Nielsen et al. (2010a). The emission factor includes the increased emission during start/stop of the engines estimated by Nielsen et al. (2008). Emission factor time series for the years 1990-2007 have been estimated based on Nielsen & Illerup (2003). These three references are discussed below.

Nielsen et al. (2010a):

CH₄ emission factors for gas engines were estimated for 2003-2006 and for 2007-2010. The dataset was split in two, due to new emission limits for engines from October 2006. The emission factors were based on emission measurements from 366 (2003-2006) and 157 (2007-2010) engines respectively. The engines from which emission measurements were available for 2007-2010 represented 38 % of the gas consumption. The emission factors were estimated based on fuel consumption for each gas engine type and the emission factor for each engine type. The majority of emission measurements that were not performed within the project related solely to the emission of total unburned hydrocarbon (CH₄ + NMVOC). A constant disaggregation factor was estimated based on 9 emission measurements including both CH₄ and NMVOC.

Nielsen & Illerup (2003):

The emission factor for natural gas engines was based on 291 emission measurements in 114 different plants. The plants from which emission measurements were available represented 44 % of the total gas consumption in gas engines in year 2000.

Nielsen et al. (2008):

This study calculated a start/stop correction factor. This factor was applied to the time series estimated in Nielsen & Illerup (2003). Further, the correction factors were applied in Nielsen et al. (2010a).

The emission factor for lean-burn gas engines is relatively high, especially for pre-chamber engines, which account for more than half the gas consumption in Danish gas engines. However, the emission factors for different pre-chamber engine types differ considerably.

The installation of natural gas engines in decentralised CHP plants in Denmark has taken place since 1990. The first engines installed were relatively small open-chamber engines but later mainly pre-chamber engines were installed. As mentioned above, pre-chamber engines have a higher emission factor than open-chamber engines; therefore, the emission factor has increased during the period 1990-1995. After that, technical improvements of the engines have been implemented as a result of upcoming emission limits that most installed gas engines had to meet in late 2006 (DEPA, 2005).

The time series were based on:

- Full load emission factors for different engine types in year 2000 (Nielsen & Illerup, 2003), 2003-2006 and 2007-2010 (Nielsen et al., 2010a).
- Data for year of installation for each engine and fuel consumption of each engine 1994-2002 from the Danish Energy Agency (DEA, 2003).
- Research concerning the CH₄ emission from gas engines carried out in 1997 (Nielsen & Wit, 1997).
- Correction factors including increased emission during start/stop of the engines (Nielsen et al., 2008).

Table 3.2.29 Time series for the CH₄ emission factor for natural gas fuelled engines.

Year	Emission factor, g per GJ
1990	266
1991	309
1992	359
1993	562
1994	623
1995	632
1996	616
1997	551
1998	542
1999	541
2000	537
2001	522
2002	508
2003	494
2004	479
2005	465
2006	473
2007-2020	481

Gas engines, biogas

The emission factor for biogas engines was estimated to 434 g per GJ in 2007-2020. The emission factor is lower than the factor for natural gas mainly because most biogas-fuelled engines are lean-burn open-chamber engines - not prechamber engines.

Time series for the emission factor have been estimated. The emission factors for biogas engines were based on Nielsen et al. (2010a) and Nielsen & Illerup (2003). The two references are discussed below. The time series are shown in Table 3.2.30.

Nielsen et al. (2010a):

CH₄ emission factors for gas engines were estimated for 2006 based on emission measurements performed in 2003-2010. The emission factor was based on emission measurements from 10 engines. The engines from which emission measurements were available represented 8 % of the gas consumption. The emission factor was estimated based on fuel consumption for each gas engine type and the emission factor for each engine type. The majority of emission measurements that were not performed within the project related solely to the emission of total unburned hydrocarbon (CH₄ + NMVOC). A constant disaggregation factor was estimated based on 3 emission measurements including both CH₄ and NMVOC.

Nielsen & Illerup (2003):

The emission factor for natural gas engines was based on 18 emission measurements from 13 different engines. The engines from which emission measurements were available represented 18 % of the total biogas consumption in gas engines in year 2000.

Table 3.2.30 Time series for the CH₄ emission factor for biogas-fuelled engines.

Year	Emission factor, g per GJ
1990	239
1991	251
1992	264
1993	276
1994	289
1995	301
1996	305
1997	310
1998	314
1999	318
2000	323
2001	342
2002	360
2003	379
2004	397
2005	416
2006	434
2007-2020	434

Gas turbines, natural gas

The emission factor for gas turbines was estimated to be below 1.7 g per GJ in 2005 (Nielsen et al., 2010a). The emission factor was based on emission measurements on five plants. The emission factor in year 2000 was 1.5 g per GJ (Nielsen & Illerup, 2003). A time series has been estimated.

CHP, wood

The emission factor for CHP plants combusting wood was estimated to be below 3.1 g per GJ (Nielsen et al., 2010a) and the emission factor 3.1 g per GJ has been applied for all years. The emission factor was based on emission measurements on two plants.

CHP, straw

The emission factor for CHP plants combusting straw was estimated to be below 0.47 g per GJ (Nielsen et al., 2010a) and the emission factor 0.47 g per GJ has been applied for all years. The emission factor was based on emission measurements on four plants.

CHP, waste

The emission factor for CHP plants combusting waste was estimated to be below 0.34 g per GJ in 2006 (Nielsen et al., 2010a) and 0.59 g per GJ in year 2000 (Nielsen & Illerup, 2003). A time series has been estimated. The emission factor was based on emission measurements on nine plants.

The emission factor has also been applied for district heating plants.

Residential wood combustion

The emission factor for residential wood combustion (not including wood pellets) is based on technology specific data. The emission factor time series is shown in Table 3.2.31.

Table 3.2.31 CH₄ emission factor time series for residential wood combustion¹⁾.

Year	Emission factor, g per GJ
1990	327
1991	321
1992	314
1993	308
1994	302
1995	296
1996	289
1997	283
1998	276
1999	270
2000	263
2001	256
2002	248
2003	240
2004	227
2005	215
2006	206
2007	197
2008	188
2009	178
2010	167
2011	160
2012	152
2013	145
2014	138
2015	131
2016	124
2017	117
2018	111
2019	105
2020	99

1) Wood pellets not included.

The emission factors for each technology and the corresponding reference are shown in Table 3.2.32. The emission factor time series is estimated based on time series (1990-2020) for wood consumption in each technology (Nielsen et al., 2021).

Table 3.2.32 Technology specific CH₄ emission factors for residential wood combustion.

Technology	Emission factor, Reference g per GJ	
Stoves (-1989)	430	Methane emissions from residential biomass combustion, Paulrud et al. (2005) (SMED report, Sweden)
Stoves (1990-2007)	215	Assumed ½ the emission factor for stoves (-1989).
Stoves (2008-2014)	125	Estimated based on the emission factor for stoves (1990-2007) and the emission factors for NMVOC.
Stoves (2015-2016)	125	Same as stoves (2008-2014)
Stoves (2017-)	125	Same as stoves (2008-2014)
Eco labelled stoves / new advanced stoves (-2014)	2	Low emissions from wood burning in an ecolabelled residential boiler. Olsson & Kjällstrand (2005).
Eco labelled stoves / new advanced stoves (2015-2016)	2	Same as advanced/ecolabelled stoves
Eco labelled stoves / new advanced stoves (2017-)	2	Same as advanced/ecolabelled stoves
Open fireplaces and similar	430	Assumed equal to stoves (-1989).
Masonry heat accumulating stoves and similar	215	Assumed equal to stoves (-1989).
Boilers with accumulation tank (-1979)	211	Methane emissions from residential biomass combustion, Paulrud et al 2005 (SMED report, Sweden)
Boilers without accumulation tank (-1979)	256	Methane emissions from residential biomass combustion, Paulrud et al 2005 (SMED report, Sweden)
Boilers with accumulation tank (1980-)	50	Emission characteristics of modern and old-type residential boilers fired with wood logs and wood pellets. Johansson et al. (2004)
Boilers without accumulation tank (1980-)	50	Emission characteristics of modern and old-type residential boilers fired with wood logs and wood pellets. Johansson et al. (2004)

The time series for wood consumption in the 14 different technologies are illustrated in Figure 3.2.37. The consumption in new/ecolabelled stoves has increased. Details about disaggregation of the wood consumption between technologies are given in Nielsen et al. (2021).

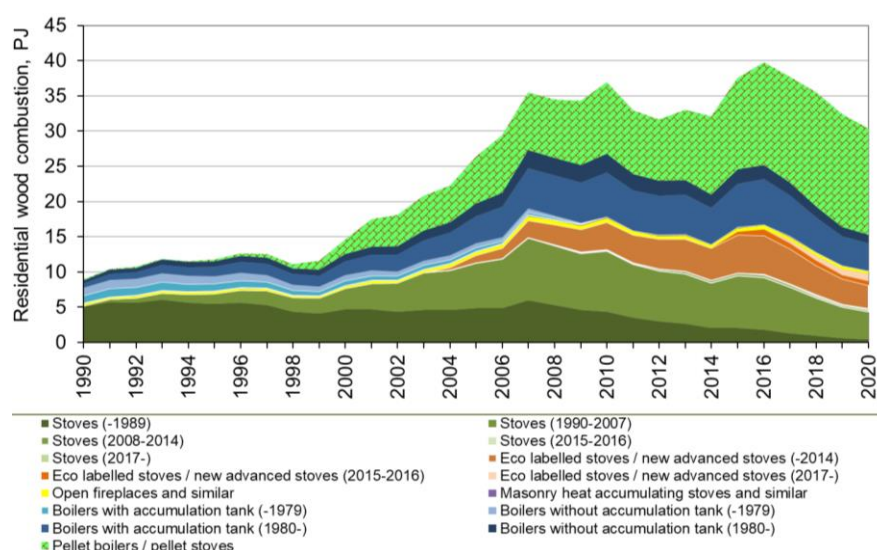

Figure 3.2.37 Technology specific wood consumption in residential plants. The consumption of wood pellets is included in the figure.

Wood pellets

The emission factor for wood pellets refer to Paulrud et al. (2005). For further details, see Nielsen et al. (2021).

Other stationary combustion plants

Emission factors for other plants refer to the IPCC Guidelines (IPCC, 2006).

N₂O emission factors

The N₂O emission factors applied for the 2020 inventory are listed in Table 3.2.33. Time series have been estimated for natural gas fuelled gas turbines and refinery gas fuelled turbines. All other emission factors have been applied unchanged for 1990-2020.

Emission factors for natural gas fuelled reciprocating engines, natural gas fuelled gas turbines, CHP plants < 300 MW combusting wood, straw or residual oil, waste incineration plants, engines fuelled by gas oil and gas engines fuelled by biomass gasification gas all refer to emission measurements carried out on Danish plants, Nielsen et al. (2010a).

The emission factor for coal-powered plants in public power plants refers to research conducted by Elsam (now part of Ørsted).

Plant specific emission factors have been included for two industrial plants.

The emission factor for offshore gas turbines has been assumed to follow the time series for natural gas fuelled gas turbines in Danish CHP plants. There is no evidence to suggest that offshore gas turbines have different emission characteristics for N₂O compared to onshore natural gas turbines and the emission factor is considered applicable.

The emission factor for natural gas fuelled gas turbines has been applied for refinery gas fuelled gas turbines. Refinery gas has similar properties as natural gas, i.e. similar nitrogen content in the fuel, which means that N₂O formation will be similar under similar combustion conditions.

All emission factors that are not nationally referenced refer to the IPCC Guidelines (IPCC, 2006).

Table 3.2.33 N₂O emission factors 2020.

Fuel group	Fuel	CRF source category	CRF source category	SNAP	Emission factor, g per GJ	Reference		
SOLID	Coal	1A1a	Public electricity and heat production	0101	0.8	Henriksen (2005)		
				0102	1.4	IPCC (2006), Tier 3, Table 2.6, Utility source, pulverised bituminous coal, wet bottom boiler.		
		1A2 a-g	Industry	03	1.5	IPCC (2006), Tier 1, Table 2-3, Manufacturing industries, coal		
		1A4b i	Residential	0202	1.5	IPCC (2006), Tier 1, Table 2-5, Residential, coal		
		1A4c i	Agriculture/ Forestry	0203	1.5	IPCC (2006), Tier 1, Table 2-4, Commercial, coal ¹⁾		
	BKB	1A4b i	Residential	0202	1.5	IPCC (2006), Tier 1, Table 2-5, Residential, brown coal briquettes		
	Coke oven coke	1A2 a-g	Industry	03	1.5	IPCC (2006), Tier 1, Table 2-3, Industry, coke oven coke		
					020200	1.5	IPCC (2006), Tier 1, Table 2-5, Residential, coke oven coke	
	Anodic carbon	1A2 a-g	Industry	03	1.5	IPCC (2006), Tier 1, Table 2-3, manufacturing industries, other bituminous coal		
	Fossil fly ash	1A1a	Public electricity and heat production	0101	0.8	Assumed equal to coal.		
	LIQ-UID	Petroleum coke	1A2 a-g	Industry – other	03	0.6	IPCC (2006), Tier 1, Table 2-3, Industry, petroleum coke	
					031600	1.5	-	
			1A4a	Commercial/ Institutional	0201	0.6	IPCC (2006), Tier 1, Table 2-4, Commercial, petroleum coke	
1A4b i			Residential	0202	0.6	IPCC (2006), Tier 1, Table 2-5, Residential, petroleum coke		
1A4c i			Agriculture/ Forestry	0203	0.6	IPCC (2006), Tier 1, Table 2-5, Residential/Agricultural, petroleum coke		
Residual oil		1A1a	Public electricity and heat production	010101	0.3	IPCC (2006), Tier 3, Table 2-6, Utility, residual fuel oil		
				010102	5	Nielsen et al. (2010a)		
				010103				
				010104	0.6	IPCC (2006), Tier 1, Table 2-2, Energy industries, residual fuel oil		
				010105				
				010203	0.3	IPCC (2006), Tier 3, Table 2-6, Utility, residual fuel oil		
		1A1b	Petroleum refining	010306	0.6	IPCC (2006), Tier 1, Table 2-2, Energy industries, residual fuel oil		
		1A2 a-g	Industry	03	5	Nielsen et al. (2010a)		
		Engines			0.6	IPCC (2006), Tier 1, Table 2-3, manufacturing industries and construction, residual fuel oil.		
		1A4a			Commercial/ Institutional	0201	0.3	IPCC (2006), Tier 3, Table 2-10, Commercial, fuel oil boilers
		1A4b i			Residential	0202	0.6	IPCC (2006), Tier 1, Table 2-5, Residential, residual fuel oil
		1A4c i			Agriculture/ Forestry	0203	0.3	IPCC (2006), Tier 3, Table 2-10, Commercial, fuel oil boilers ¹⁾
Gas oil	1A1a	Public electricity and heat production	010101	0.4	IPCC (2006), Tier 3, Table 2-6, Utility, gas oil boilers			
			010102					
			010103					
			010104	0.6	IPCC (2006), Tier 1, Table 2-2, Energy industries, gas oil			
			010105	2.1	Nielsen et al. (2010a)			
			0102	0.4	IPCC (2006), Tier 3, Table 2-6, Utility, gas oil boilers			

Fuel group	Fuel	CRF source category	CRF source category	SNAP	Emission factor, g per GJ	Reference		
		1A1b	Petroleum refining	010306	0.6	IPCC (2006), Tier 1, Table 2-2, Energy industries, gas oil		
		1A1c	Oil and gas extraction	010500	0.4	IPCC (2006), Tier 3, Table 2-6, Utility, gas oil boilers		
		1A2 a-g	Industry	03	0.4	IPCC (2006), Tier 3, Table 2-7, Industry, gas oil boilers		
		Tur-bines		0.6	IPCC (2006), Tier 1, Table 2-3, Industry, gas oil			
		Engines		2.1	Nielsen et al. (2010a)			
		1A4a	Commercial/ Institutional	0201	0.4	IPCC (2006), Tier 3, Table 2-10, Commercial, gas oil boilers		
		Engines		2.1	Nielsen et al. (2010a)			
		1A4b i	Residential	0202	0.6	IPCC (2006), Tier 1, Table 2-5, Residential, gas oil		
		Engines		2.1	Nielsen et al. (2010a)			
		1A4c	Agriculture/ Forestry	0203	0.4	IPCC (2006), Tier 3, Table 2-10, Commercial, gas oil boilers ¹⁾		
		Engines		2.1	Nielsen et al. (2010a)			
	Kerosene	1A2 a-g	Industry	03	0.6	IPCC (2006), Tier 1, Table 2-3, Industry, other kerosene		
		1A4a	Commercial/ Institutional	0201	0.6	IPCC (2006), Tier 1, Table 2-4, Commercial, other kerosene		
		1A4b i	Residential	0202	0.6	IPCC (2006), Tier 1, Table 2-5, Residential, other kerosene		
		1A4c i	Agriculture/ Forestry	0203	0.6	IPCC (2006), Tier 1, Table 2-4, Commercial, other kerosene ¹⁾		
	LPG	1A1a	Public electricity and heat production	0101	0.1	IPCC (2006), Tier 1, Table 2-2, Energy industries, LPG		
		0102		0.1	IPCC (2006), Tier 1, Table 2-2, Energy industries, LPG			
		1A1b	Petroleum refining	010306	0.1	IPCC (2006), Tier 1, Table 2-2, Energy industries, LPG		
		1A2 a-g	Industry	03	0.1	IPCC (2006), Tier 1, Table 2-3, Industry, LPG		
		1A4a	Commercial/ Institutional	0201	0.1	IPCC (2006), Tier 1, Table 2-4, Commercial, LPG		
		1A4b i	Residential	0202	0.1	IPCC (2006), Tier 1, Table 2-5, Residential, LPG		
		1A4c i	Agriculture/ Forestry	0203	0.1	IPCC (2006), Tier 1, Table 2-5, Residential/Agricultural, LPG		
	Refinery gas	1A1b	Petroleum refining	010304	1	Assumed equal to natural gas fuelled turbines. Based on Nielsen et al. (2010a).		
		010306		0.1	IPCC (2006), Tier 1, Table 2-2, Energy industries, refinery gas			
GAS	Natural gas	1A1a	Public electricity and heat production	010101	1	IPCC (2006), Tier 3, Table 2-6, Natural gas, Utility, boiler		
				010102				
				010103				
				010104			1	Nielsen et al. (2010a)
				010105			0.58	Nielsen et al. (2010a)
			0102	1	IPCC (2006), Tier 3, Table 2-6, Natural gas, Utility, boiler			
		1A1b	Petroleum refining	010306	1	IPCC (2006), Tier 3, Table 2-6, Natural gas, Utility, boiler		
		1A1c	Oil and gas extraction	010504	1	Nielsen et al. (2010a)		
		1A2 a-g	Industry	03	1	IPCC (2006), Tier 3, Table 2-7, Industry, natural gas boilers		
							Gas turbines	1
Engines	0.58						Nielsen et al. (2010a)	
1A4a	Commercial/ Institutional	020100	1	IPCC (2006), Tier 3, Table 2-10, Commercial, natural gas boilers				
020103								

Fuel group	Fuel	CRF source category	CRF source category	SNAP	Emission factor, g per GJ	Reference
				Engines	0.58	Nielsen et al. (2010a)
		1A4b i	Residential	0202	1	IPCC (2006), Tier 3, Table 2-9, Residential, natural gas boilers
				Engines	0.58	Nielsen et al. (2010a)
		1A4c i	Agriculture/ Forestry	0203	1	IPCC (2006), Tier 3, Table 2-10, Commercial, natural gas boilers ¹⁾
				Engines	0.58	Nielsen et al. (2010a)
WASTE	Waste	1A1a	Public electricity and heat production	0101 0102	1.2	Nielsen et al. (2010a)
		1A2 a-g	Industry	03	4	IPCC (2006), Tier 1, Table 2-3, Industry, wastes
		1A4a	Commercial/ Institutional	0201	4	IPCC (2006), Tier 1, Table 2-4, Commercial, municipal wastes
	Industrial waste	1A2 a-g	Industry	03	4	IPCC (2006), Tier 1, Table 2-3, Industry, industrial wastes
BIO-MASS	Wood	1A1a	Public electricity and heat production	0101 0102	0.8 4	Nielsen et al. (2010a) IPCC (2006), Tier 1, Table 2-2, Energy industries, wood
		1A2 a-g	Industry	03	7	IPCC (2006), Table 2-7 Industrial source emission factors, wood / wood waste boilers
		1A4a	Commercial/ Institutional	0201	4	IPCC (2006), Tier 1, Table 2-4, Commercial, wood
		1A4b i	Residential	0202	4	IPCC (2006), Tier 1, Table 2-5, Residential, wood
		1A4c i	Agriculture/ Forestry	0203	4	IPCC (2006), Tier 1, Table 2-5, Agriculture, wood
	Straw	1A1a	Public electricity and heat production	0101 0102	1.1 4	Nielsen et al. (2010a) IPCC (2006), Tier 1, Table 2-2, Energy industries, other primary solid biomass
		1A4b i	Residential	0202	4	IPCC (2006), Tier 1, Table 2-5, Residential, other primary solid biomass
		1A4c i	Agriculture/ Forestry	0203	4	IPCC (2006), Tier 1, Table 2-5, Agriculture, other primary solid biomass
	Wood pellets	1A1a	Public electricity and heat production	0101 0102	0.8 4	Nielsen et al. (2010a) IPCC (2006), Tier 1, Table 2-2, Energy industries, wood
		1A2 a-g	Industry	03	4	IPCC (2006), Tier 1, Table 2-3, Industry, wood
		1A4a	Commercial/ Institutional	0201	4	IPCC (2006), Tier 1, Table 2-4, Commercial, wood
		1A4b i	Residential	0202	4	IPCC (2006), Tier 1, Table 2-5, Residential, wood
	Bio oil	1A1a	Public electricity and heat production	0101 0102 Engines	0.6 2.1	IPCC (2006), Tier 3, Table 2-2, Utility, biodiesels Assumed equal to gas oil. Based on Nielsen et al. (2010a)
		1A2 a-g	Industry	03	0.4	Assumed equal to gas oil.
		1A4b i	Residential	0202	0.6	IPCC (2006), Tier 1, Table 2-5, Residential, biodiesels
	Biogas	1A1a	Public electricity and heat production	0101 0102 Engines	0.1 1.6	IPCC (2006), Tier 1, Table 2-2, Energy industries, other biogas Nielsen et al. (2010a)
		1A2 a-g	Industry	03	0.1	IPCC (2006), Tier 1, Table 2-3, Industry, other biogas

Fuel group	Fuel	CRF source category	CRF source category	SNAP	Emission factor, g per GJ	Reference
				Engines	1.6	Nielsen et al. (2010a)
		1A4a	Commercial/ Institutional	0201	0.1	IPCC (2006), Tier 1, Table 2,4, Commercial, other biogas
				Engines	1.6	Nielsen et al. (2010a)
		1A4b	Residential	0202	1	Assumed equal to natural gas.
		1A4c i	Agriculture/ Forestry	0203	0.1	IPCC (2006), Tier 1, Table 2-5, Agriculture, other biogas
				Engines	1.6	Nielsen et al. (2010a)
Bio gasification gas		1A1a	Public electricity and heat production	010101	0.1	Assumed equal to biogas.
				010105	2.7	Nielsen et al. (2010a)
		1A4a	Commercial/ Institutional	020105	2.7	Nielsen et al. (2010a)
Bio natural gas		1A1a	Public electricity and heat production	0101 or 0102	1	Assumed equal to natural gas.
		1A2 a-g	Industry	03	1	Assumed equal to natural gas.
		1A4a	Commercial/ Institutional	0201	1	Assumed equal to natural gas.
		1A4b	Residential	0202	1	Assumed equal to natural gas.
		1A4c	Agriculture/ Forestry	0203	1	Assumed equal to natural gas.

1) In Denmark, plants in Agriculture/Forestry are similar to Commercial plants.

3.2.6 Uncertainty

Uncertainty estimates include uncertainty regarding the total emission inventory as well as uncertainty regarding trends.

Methodology

The uncertainty for greenhouse gas emissions have been estimated according to the IPCC Guidelines (IPCC, 2006). This year the uncertainty has been estimated only by approach 1. Approach 1 is further described in Chapter 1.7.

Approach 1 is based on a normal distribution and a confidence interval of 95 %.

The input data for the approach 1 are:

- Emission data for the base year and the latest year.
- Uncertainties for emission factors
- Uncertainty for fuel consumption rates.

The emission source categories applied are listed in Table 3.2.34.

Source categories

Due to large differences in data uncertainty, some emission source categories have been further disaggregated than suggested in the IPCC Guidelines (2006):

- For five different fuels, CO₂ emissions based on ETS data and on non-ETS data have been considered two different emission sources.
- CH₄ emission from natural gas fuelled engines
- CH₄ emission from biogas fuelled engines
- CH₄ emission from residential wood combustion
- CH₄ emission from residential and agricultural combustion of straw
- N₂O emission from residential wood combustion
- N₂O emission from residential and agricultural combustion of straw

The separate uncertainty estimation for gas engine CH₄ emission and CH₄ emission from other plants is applied, because in Denmark, the CH₄ emission from gas engines is much larger than the emission from other stationary combustion plants, and the CH₄ emission factor for gas engines is estimated with a much smaller uncertainty level than for other stationary combustion plants.

The 2020 uncertainty levels have been applied in uncertainty calculation.

Fuel

The applied uncertainty rates for fuel consumption are shown below.

Table 3.2.34 Uncertainties for fuel consumption 2020.

IPCC Source category	2020	Reference
1A1, 1A2, 1A4 St. comb. Coal, ETS data, CO ₂	0.5%	ETS data
1A1, 1A2, 1A4 St. comb. Coal, no ETS data, CO ₂	1.6%	Estimated based on IPCC (2006) values.
1A1, 1A2, 1A4 St. comb., BKB, CO ₂	2.9%	Estimated based on IPCC (2006) values.
1A1, 1A2, 1A4 St. comb., Coke oven coke, CO ₂	1.8%	Estimated based on IPCC (2006) values.
1A1, 1A2, 1A4 St. comb., Fossil waste, ETS data, CO ₂	2%	DCE assumption
1A1, 1A2, 1A4 St. comb., Fossil waste, no ETS data, CO ₂	5%	DCE assumption
1A1, 1A2, 1A4 St. comb., Petroleum coke, ETS data, CO ₂	0.5%	ETS data
1A1, 1A2, 1A4 St. comb., Petroleum coke, no ETS data, CO ₂	2.0%	Estimated based on IPCC (2006) values.
1A1, 1A2, 1A4 St. comb., Residual oil, ETS data, CO ₂	0.5%	ETS data
1A1, 1A2, 1A4 St. comb., Residual oil, no ETS data, CO ₂	1.0%	Estimated based on IPCC (2006) values.
1A1, 1A2, 1A4 St. comb., Gas oil, CO ₂	2.4%	Estimated based on IPCC (2006) values.
1A1, 1A2, 1A4 St. comb., Kerosene, CO ₂	2.8%	Estimated based on IPCC (2006) values.
1A1, 1A2, 1A4 St. comb., LPG, CO ₂	1.9%	Estimated based on IPCC (2006) values.
1A1b, St. comb., Refinery gas, CO ₂	1.0%	Estimated based on IPCC (2006) values.
1A1, 1A2, 1A4, Stationary combustion, Natural gas, onshore, CO ₂	1.5%	Estimated based on IPCC (2006) values. Offshore gas turbines not included in this category.
1A1c Off shore gas turbines, Natural gas, CO ₂	0.5%	ETS data for 2020, IPCC (2006) for 1990.
1A1, Stationary Combustion, SOLID, CH ₄	1.0%	IPCC (2006), less than 1%
1A1, Stationary Combustion, LIQUID, CH ₄	1.0%	IPCC (2006), less than 1%
1A1, Stationary Combustion, not engines, GAS, CH ₄	1.0%	IPCC (2006), less than 1%
1A1, Stationary Combustion, WASTE, CH ₄	3.0%	DCE assumption. The uncertainty for the total consumption of waste is lower than the uncertainty for the fossil part.
1A1, Stationary Combustion, not engines, BIOMASS, CH ₄	3.0%	DCE assumption
1A2, Stationary Combustion, SOLID, CH ₄	2.0%	IPCC (2006)
1A2, Stationary Combustion, LIQUID, CH ₄	2.0%	IPCC (2006)
1A2, Stationary Combustion, not engines, GAS, CH ₄	2.0%	IPCC (2006)
1A2, Stationary Combustion, WASTE, CH ₄	3.0%	DCE assumption. The uncertainty for the total consumption of waste is lower than the uncertainty for the fossil part.
1A2, Stationary Combustion, not engines, BIOMASS, CH ₄	3.0%	IPCC (2006)
1A4, Stationary Combustion, SOLID, CH ₄	3.0%	IPCC (2006)
1A4, Stationary Combustion, LIQUID, CH ₄	3.0%	IPCC (2006)
1A4, Stationary Combustion, not engines, GAS, CH ₄	3.0%	IPCC (2006)
1A4, Stationary Combustion, WASTE, CH ₄	3.0%	DCE assumption. The uncertainty for the total consumption of waste is lower than the uncertainty for the fossil part.
1A4, Stationary Combustion, not engines, not residential wood and not residential/agricultural straw, BIOMASS, CH ₄	3.0%	IPCC (2006)
1A4, Stationary Combustion, Residential wood combustion, CH ₄	10.0%	DCE assumption
1A4, Stationary Combustion, Residential and agricultural straw combustion, CH ₄	10.0%	DCE assumption
1A1, 1A2, 1A4 Natural gas fuelled engines, GAS, CH ₄	1.0%	Lindgren (2010)
1A1, 1A2, 1A4 Biogas fuelled engines, GAS, CH ₄	3.0%	DCE assumption
1A1, Stationary Combustion, SOLID, N ₂ O	1.0%	IPCC (2006), less than 1%
1A1, Stationary Combustion, LIQUID, N ₂ O	1.0%	IPCC (2006), less than 1%
1A1, Stationary Combustion, GAS, N ₂ O	1.0%	IPCC (2006), less than 1%
1A1, Stationary Combustion, WASTE, N ₂ O	3.0%	DCE assumption

IPCC Source category	2020	Reference
1A1, Stationary Combustion, BIOMASS, N ₂ O	3.0%	DCE assumption
1A2, Stationary Combustion, SOLID, N ₂ O	2.0%	IPCC (2006)
1A2, Stationary Combustion, LIQUID, N ₂ O	2.0%	IPCC (2006)
1A2, Stationary Combustion, GAS, N ₂ O	2.0%	IPCC (2006)
1A2, Stationary Combustion, WASTE, N ₂ O	3.0%	DCE assumption
1A2, Stationary Combustion, BIOMASS, N ₂ O	3.0%	DCE assumption
1A4, Stationary Combustion, SOLID, N ₂ O	3.0%	IPCC (2006)
1A4, Stationary Combustion, LIQUID, N ₂ O	3.0%	IPCC (2006)
1A4, Stationary Combustion, GAS, N ₂ O	3.0%	IPCC (2006)
1A4, Stationary Combustion, WASTE, N ₂ O	3.0%	DCE assumption
1A4, Stationary Combustion, not residential wood and not residential/agricultural straw, BIOMASS, N ₂ O	3.0%	DCE assumption
1A4b, Stationary Combustion, Residential wood combustion, N ₂ O	10.0%	DCE assumption
1A4b/c, Stationary Combustion, Residential and agricultural straw combustion, N ₂ O	10.0%	DCE assumption

Emission factors

Uncertainties for emission factors are shown in Table 3.2.35.

Table 3.2.35 Uncertainties for emission factors, 2020.

IPCC Source category	2020	Reference
1A1, 1A2, 1A4 St. comb. Coal, ETS data, CO ₂	0.3%	ETS data, 2020 estimate
1A1, 1A2, 1A4 St. comb. Coal, no ETS data, CO ₂	1.0%	DCE assumption
1A1, 1A2, 1A4 St. comb., BKB, CO ₂	5.0%	IPCC (2000), chapter 2.1.1.6.
1A1, 1A2, 1A4 St. comb., Coke oven coke, CO ₂	5.0%	IPCC (2000), chapter 2.1.1.6.
1A1, 1A2, 1A4 St. comb., Fossil waste, ETS data, CO ₂	3.0%	ETS data, DCE estimate based on Astrup et al. (2012).
1A1, 1A2, 1A4 St. comb., Fossil waste, no ETS data, CO ₂	10.0%	Non-ETS data, DCE estimate based on Astrup et al. (2012).
1A1, 1A2, 1A4 St. comb., Petroleum coke, ETS data, CO ₂	0.5%	ETS data, 2020 estimate
1A1, 1A2, 1A4 St. comb., Petroleum coke, no ETS data, CO ₂	5.0%	IPCC (2000), chapter 2.1.1.6.
1A1, 1A2, 1A4 St. comb., Residual oil, ETS data, CO ₂	0.5%	ETS data, 2015 estimate
1A1, 1A2, 1A4 St. comb., Residual oil, no ETS data, CO ₂	2.0%	Jensen & Lindroth (2002).
1A1, 1A2, 1A4 St. comb., Gas oil, CO ₂	1.3%	DCE estimate.
1A1, 1A2, 1A4 St. comb., Kerosene, CO ₂	3.0%	Based on interval in IPCC (2006).
1A1, 1A2, 1A4 St. comb., LPG, CO ₂	4.0%	Based on interval in IPCC (2006).
1A1b, St. comb., Refinery gas, CO ₂	0.5%	1990: IPCC (2000), chapter 2.1.1.6. 2020: DCE assumption, EU ETS data.
1A1, 1A2, 1A4, Stationary combustion, Natural gas, onshore, CO ₂	0.4%	Lindgren (2010). Personal communication.
1A1c Offshore gas turbines, Natural gas, CO ₂	0.5%	ETS data for 2020, but not for 1990
1A1, Stationary Combustion, SOLID, CH ₄	100%	Based on interval in IPCC (2006), table 2.12
1A1, Stationary Combustion, LIQUID, CH ₄	100%	Based on interval in IPCC (2006), table 2.12
1A1, Stationary Combustion, not engines, GAS, CH ₄	100%	Based on interval in IPCC (2006), table 2.12
1A1, Stationary Combustion, WASTE, CH ₄	100%	Based on interval in IPCC (2006), table 2.12
1A1, Stationary Combustion, not engines, BIOMASS, CH ₄	100%	Based on interval in IPCC (2006), table 2.12
1A2, Stationary Combustion, SOLID, CH ₄	100%	Based on interval in IPCC (2006), table 2.12
1A2, Stationary Combustion, LIQUID, CH ₄	100%	Based on interval in IPCC (2006), table 2.12
1A2, Stationary Combustion, not engines, GAS, CH ₄	100%	Based on interval in IPCC (2006), table 2.12
1A2, Stationary Combustion, WASTE, CH ₄	100%	Based on interval in IPCC (2006), table 2.12
1A2, Stationary Combustion, not engines, BIOMASS, CH ₄	100%	Based on interval in IPCC (2006), table 2.12
1A4, Stationary Combustion, SOLID, CH ₄	100%	Based on interval in IPCC (2006), table 2.12
1A4, Stationary Combustion, LIQUID, CH ₄	100%	Based on interval in IPCC (2006), table 2.12
1A4, Stationary Combustion, not engines, GAS, CH ₄	100%	Based on interval in IPCC (2006), table 2.12
1A4, Stationary Combustion, WASTE, CH ₄	100%	Based on interval in IPCC (2006), table 2.12
1A4, Stationary Combustion, not engines, not residential wood and not residential/agricultural straw, BIOMASS, CH ₄	100%	Based on interval in IPCC (2006), table 2.12
1A4, Stationary Combustion, Residential wood combustion, CH ₄	150%	Upper value in IPCC (2006), table 2.12.

IPCC Source category	2020	Reference
1A4, Stationary Combustion, Residential and agricultural straw combustion, CH ₄	150%	Upper value in IPCC (2006), table 2.12.
1A1, 1A2, 1A4 Natural gas fuelled engines, GAS, CH ₄	2%	1990: DCE estimate based on Nielsen et al. (2010a). 2018: Jørgensen et al. (2010). Uncertainty data for NMVOC + CH ₄ .
1A1, 1A2, 1A4 Biogas fuelled engines, GAS, CH ₄	10%	DCE estimate based on Nielsen et al. (2010a).
1A1, Stationary Combustion, SOLID, N ₂ O	400%	DCE, rough estimate based on a default value of 400 % when the emission factor is based on emission measurements from plants in Denmark.
1A1, Stationary Combustion, LIQUID, N ₂ O	1000%	IPCC (2000)
1A1, Stationary Combustion, GAS, N ₂ O	750%	DCE, rough estimate based on a default value of 400 % when the emission factor is based on emission measurements from plants in Denmark and 1000 % if not.
1A1, Stationary Combustion, WASTE, N ₂ O	400%	DCE, rough estimate based on a default value of 400 % when the emission factor is based on emission measurements from plants in Denmark.
1A1, Stationary Combustion, BIOMASS, N ₂ O	400%	DCE, rough estimate based on a default value of 400 % when the emission factor is based on emission measurements from plants in Denmark.
1A2, Stationary Combustion, SOLID, N ₂ O	400%	DCE, rough estimate based on a default value of 400 % when the emission factor is based on emission measurements from plants in Denmark.
1A2, Stationary Combustion, LIQUID, N ₂ O	1000%	IPCC (2000)
1A2, Stationary Combustion, GAS, N ₂ O	750%	DCE, rough estimate based on a default value of 400 % when the emission factor is based on emission measurements from plants in Denmark and 1000 % if not.
1A2, Stationary Combustion, WASTE, N ₂ O	400%	DCE, rough estimate based on a default value of 400 % when the emission factor is based on emission measurements from plants in Denmark.
1A2, Stationary Combustion, BIOMASS, N ₂ O	400%	DCE, rough estimate based on a default value of 400 % when the emission factor is based on emission measurements from plants in Denmark.
1A4, Stationary Combustion, SOLID, N ₂ O	400%	DCE, rough estimate based on a default value of 400 % when the emission factor is based on emission measurements from plants in Denmark.
1A4, Stationary Combustion, LIQUID, N ₂ O	1000%	IPCC (2000)
1A4, Stationary Combustion, GAS, N ₂ O	750%	DCE, rough estimate based on a default value of 400 % when the emission factor is based on emission measurements from plants in Denmark and 1000 % if not.
1A4, Stationary Combustion, WASTE, N ₂ O	400%	DCE, rough estimate based on a default value of 400 % when the emission factor is based on emission measurements from plants in Denmark.
1A4, Stationary Combustion, not residential wood and not residential/agricultural straw, BIOMASS, N ₂ O	400%	DCE, rough estimate based on a default value of 400 % when the emission factor is based on emission measurements from plants in Denmark.
1A4b, Stationary Combustion, Residential wood combustion, N ₂ O	500%	DCE estimate.
1A4b/c, Stationary Combustion, Residential and agricultural straw combustion, N ₂ O	500%	DCE estimate.

Results

Approach 1 uncertainty estimates for stationary combustion emission inventories are shown in Table 3.2.36. Detailed calculation sheets are provided in Annex 3A-7.

The uncertainty interval for the total greenhouse gas emission is estimated to be ± 2.6 % and the trend in greenhouse gas emissions is -67.2 % ± 0.8 %-age points. The main sources of uncertainty for greenhouse gas emissions in 2020

are N₂O emission from residential wood combustion, N₂O emission from biomass combusted in Energy industries (1A1) and N₂O emission from solid fuels combusted in industrial plants (1A2). The main sources of uncertainty in the trend in greenhouse gas emission are the N₂O emission from residential wood combustion and N₂O emissions from biomass combusted in Energy industries (1A1).

Table 3.2.36 Danish uncertainty estimates, Approach 1, 2020.

Pollutant	Uncertainty Total emission, %	Trend 1990-2020, %	Uncertainty trend, %-age points
GHG	±2.6	-67.2	±0.8
CO ₂	±0.8	-67.9	±0.4
CH ₄	±40	+18	±54
N ₂ O	±172	-2.7	±202

3.2.7 Source specific QA/QC and verification

The quality work for the Danish GHG emission inventories are accounted for in *Quality manual for the Danish emission greenhouse gas inventory, Version 3* (Nielsen et al., 2020a). The quality manual outlines the quality work undertaken by the emission inventory group at the Department of Environmental Science, Aarhus University in connection with the preparation and reporting of the Danish greenhouse gas inventory.

Information on the Danish quality work is also included in NIR Chapter 1.6. Sector specific QA/QC for stationary combustion is accounted for in this chapter.

The QA/QC defined in the Quality manual defines Critical control points and a Points of measurement. Some points of measurement are sector specific whereas others are general.

Sector specific points of measurement

Table 3.2.37 lists the sector specific points of measurement and specification about the points of measurement for stationary combustion.

Table 3.2.37 List of sectoral points of measurement, and QC for stationary combustion.

Level	CCP	Id	Description		Stationary combustion QC
Data Storage level 1	1. Accuracy	DS.1.1.1	General level of uncertainty for every dataset including the reasoning for the specific values.	Sectoral	Uncertainties are estimated and references given in NIR chapter 3.2.6.
	2. Comparability	DS1.2.1	Comparability of the emission factors/calculation parameters with data from international guidelines, and evaluation of major discrepancies.	Sectoral	In general, if national referenced emission factors differ considerably from IPCC Guideline values this is discussed in NIR chapter 3.2.5. This documentation is improved annually based on reviews. At CRF level, a project has been carried out comparing the Danish inventories with those of other countries (Fauser et al., 2013).
	3. Completeness	DS.1.3.1	Ensuring that the best possible national data for all sources are included, by setting down the reasoning behind the selection of datasets.	Sectoral	A list of external data is shown and discussed below (Table 3.2.38).
	4. Consistency	DS.1.4.1	The original external data has to be archived with proper reference.	Sectoral	It is ensured that all original external data are archived. Subsequent data processing takes place in other spreadsheets or databases. The datasets are archived annually in order to ensure that the basic data for a given report are always available in their original form. All original data for stationary combustion are archived in the emission inventory archive: ST_ENVS-Luft-Emi/Inventory/(year)/1A1 1A2 and 1A4 Stationary combustion All original data for 1) the reference approach, 2) the comparison of EU ETS sum and CRF and 3) the comparison of Eurostat data and CRF are archived in the emission inventory archive: ST_ENVS-Luft-Emi/Inventory/(year)/1A Other Energy
	6. Robustness	DS.1.6.1	Explicit agreements between the external institution holding the data and AU, DCE about the conditions of delivery.	Sectoral	For stationary combustion, a data delivery agreement is made with the DEA. DCE and DEA have renewed the data delivery agreement in 2014.

Level	CCP	Id	Description		Stationary combustion QC
					Most of the other external data sources are available due to legislation. See Table 3.2.38.
	7.Transparency	DS.1.7.1	Listing of all archived datasets and external contacts.	Sectoral	A list of external datasets and external contacts is shown in Table 3.2.38 below.
Data Processing level 1	1. Accuracy	DP.1.1.1	Uncertainty assessment for every data source not part of DS.1.1.1 as input to Data Storage level 2 in relation to type and scale of variability.	Sectoral	Uncertainties are estimated and references given in NIR chapter 3.2.6.
	2.Comparability	DP.1.2.1	The methodologies have to follow the international guidelines suggested by UNFCCC and IPCC.	Sectoral	The methodological approach is consistent with international guidelines. An overview of tiers is given in NIR Chapter 3.2.5.
	3.Completeness	DP.1.3.1	Identification of data gaps with regard to data sources that could improve quantitative knowledge.	Sectoral	The energy statistics (the basic data sheet) is considered complete. Total fuel consumption is based on the energy statistics whereas other data sources are used for specification of technology, subsectors, plant specific data etc.
	4.Consistency	DP.1.4.1	Documentation and reasoning of methodological changes during the time series and the qualitative assessment of the impact on time series consistency.	Sectoral	The two main methodological changes in the time series; implementation of Energy Producers Survey (plant specific fuel consumption data) from 1994 onwards and implementation of EU ETS data from 2006 onwards is discussed in NIR chapter 3.2.5.
	5.Correctness	DP.1.5.2	Verification of calculation results using time series.	Sectoral	Time series for activity data on SNAP and CRF source category level are used to identify possible errors. Time series for emission factors and the emission from CRF subcategories are also examined.
		DP.1.5.3	Verification of calculation results using other measures.	Sectoral	The IPCC reference approach validates the fuel consumption rates and CO ₂ emission. Except for 2015 and 2016, both differ less than 2.0 % in 1990-2020. The reference approach is included in NIR Chapter 3.4. The chapter gives an account of the differences between the national approach and the reference approach.
	7.Transparency	DP.1.7.1	The calculation principle, the equations used and the assumptions made must be described.	Sectoral	This is included in NIR chapter 3.2.5.
		DP.1.7.2	Clear reference to dataset at Data Storage level 1.	Sectoral	This is included in NIR chapter 3.2.5.
		DP.1.7.3	A manual log to collect information about recalculations.	Sectoral	A manual log is implemented in the emission database.
Data Storage	5.Correctness	DS.2.5.1	Check if a correct data import to level 2 has been made.	Sectoral	To ensure a correct connection

Level	CCP	Id	Description		Stationary combustion QC
level 2					between data on level 2 and level 1, different controls are in place, e.g. control of sums and random tests.
Data Storage level 4	4.Consistency	DS.4.4.3	The IEFs from the CRF are checked both regarding level and trend. The level is compared to relevant emission factors to ensure correctness. Large dips/jumps in the time series are explained.	Sectoral	Large dips/jumps in time series are discussed and explained in NIR chapter 3.2.3 and 3.2.4.
	5. Correctness	DS.4.5.2	Check that additional information and information related to land-use changes has been correctly aggregated compared to the individual submissions of Denmark and Greenland.	Sectoral	(Not relevant for stationary combustion)

Table 3.2.38 List of external data sources for stationary combustion.

Dataset	Data reference	Contact(s)	Description	Years included	Data agreement/ Comment
Energy Producers Survey	The Danish Energy Agency (DEA)	Kaj Stærkind	Dataset for all plants producing electricity and district heating for the public grids. For each production unit, the dataset includes the consumption of each fuel, production of heat and electricity, technology and year of installation. The dataset is regarded as complete for fuel consumption since the plants are obliged to report the data to DEA.	1994 onwards	Data agreement 2014.
Gas consumption for gas engines and gas turbines 1990-1993	The Danish Energy Agency (DEA)	Kaj Stærkind	Historical dataset for gas engines and gas turbines. For the years 1990-1994, DEA has estimated consumption of natural gas and biogas in gas engines and gas turbines (DEA, 2003). Estimated fuel consumption data for 1990-1993 was based on engine specific data for year of installation and for fuel consumption in 1994. The 1994 data were based on the Energy Producers Survey. DCE assesses that the DEA estimate is the best available data for 1990-1993.	1990-1993	No data agreement. Historical data
Basic data	The Danish Energy Agency (DEA)	Jane Rusbjerg	The Danish energy statistics. The dataset is applied for both the reference approach and the national approach. The spreadsheet from the Danish energy statistics (DEA) is used for the CO ₂ emission calculation in accordance with the IPCC reference approach and is also the first dataset applied in the national approach.	1972 and 1975 onwards	Data agreement 2014. However, the dataset is also published as part of national energy statistics.
Energy statistics for industrial subsectors	The Danish Energy Agency (DEA)	Jane Rusbjerg and Ali Zarnaghi	Disaggregation of the industrial fuel consumption. The data includes disaggregation of the fuel consumption for industrial plants. The dataset is estimated for the reporting to Eurostat. The data are included in the 2014 update of the agreement with DEA.		Included in data delivery agreement 2014.
Emission factors	See chapter regarding emission factors		Emission factors refer to a large number of sources. For specific references, see the Chapter 3.2.5 regarding emission factors. Some of the annually updated CO ₂ emission factors are based on EU ETS data, see below.		Some of the annually updated CO ₂ emission factors are based on EU ETS data, and thus included in the data delivery agreement with DEA.

Dataset	Data reference	Contact(s)	Description	Years included	Data agreement/ Comment
Annual environmental reports / environmental data / PRTR	Various plants		<p>Emissions from plants defined as large point sources</p> <p>Some large plants are obligated to report annual environmental data including emission data to PRTR. In addition, some plants publish annual environmental reports. And finally, some plant owners non-compulsory report annual emission data to DCE.</p>		<p>For other emission factors no formal data delivery agreement.</p> <p>No data agreement.</p> <p>Some plants are obligated to report data (DEPA, 2010b; DEPA, 2015) and data are published on the Danish EPA homepage.</p>
EU ETS data	The Danish Energy Agency (DEA)	Rikke Brynaa Lintrup	<p>Plant specific CO₂ emission factors and fuel consumption data.</p> <p>EU ETS data includes information on fuel consumption, heating values, carbon content of fuel, oxidation factor and CO₂ emissions. DCE receives the verified reports for all plants, which utilises a detailed estimation methodology. DCE's QC of the received data consists of comparing to calculation using standard emission factors as well as comparing reported values with those for previous years.</p>		Plants are obligated by law. The availability of detailed information is part of the data agreement with DEA (2014 update).

Additional sector specific QC procedures

Some additional sector specific QC procedures are performed.

- Check of units for fuel rate, emission factors and plant-specific emissions.
- Check of emission factors for large point sources. Emission factors for pollutants that are not plant-specific should be the same as those defined for area sources.
- Additional checks on database consistency.
- Emission factor references are included in NIR Chapter 3.2.5.
- Most country-specific emission factors are based on input from companies that have implemented some QA/QC work. The major power plant owner/operator in Denmark, Ørsted (former DONG Energy) has obtained the ISO 14001 certification for an environmental management system. The Danish Gas Technology Centre and Force Technology both run accredited laboratories for emission measurements.

Sector specific verification

The IPCC reference approach for CO₂ emission is the primary verification of the CO₂ emission from the energy sector. The reference approach for the energy sector is shown in NIR Chapter 3.4.

In addition, as part of the EU review of the reported GHG emission data, EU performs for each member state a comparison of Eurostat energy data in terms of TJ with energy data provided in the CRF. The comparison has been performed in accordance with the Commission implementing regulation (EU) No 749/2014 of 30 June 2014 and with the IPCC Guidelines (2006). The latest comparison included comparisons of the reference approach (RA) and the sectoral approach (SA) for the years 2005 and 2008-2020. The comparison of fuel consumption data in CRF and energy statistics from Eurostat is shown in NIR Annex 9 including explanation of the differences.

Finally, a verification of the Danish GHG emission inventories has been published by Fauser et al. (2013).

National external review for stationary combustion

The 2004, 2006, 2009, 2014, 2018 and 2021 updates of the sector report for stationary combustion has been reviewed by external experts (Nielsen & Illerup, 2004; Nielsen & Illerup, 2006; Nielsen et al., 2009, Nielsen et al., 2014; Nielsen et al., 2018; Nielsen, 2021). The national external review forms a vital part of the QA activities for stationary combustion.

The 2004, 2006, 2009, 2014, 2018 and 2021 updates of this report were reviewed by Jan Erik Johnsson from the Technical University of Denmark, Bo Sander from Elsam Engineering, Annemette Geertinger from FORCE Technology, Vibeke Vestergaard Nielsen, AU DCE, energy statistics experts from the Danish Energy Agency and Jytte Boll Illerup, The Danish Environmental Protection Agency.

3.2.8 Source specific recalculations and improvements

Table 3.2.39 shows recalculations of the CO₂, CH₄ and N₂O emissions. Emissions reported this year have been compared to emissions reported last year.

Sector specific recalculations for 2019 are shown in Table 3.2.40.

The main recalculations are discussed below.

Table 3.2.39 Recalculations. GHG emissions reported this year compared to emissions reported last year.

GHG	1990	1991	1992	1993	1994	1995	1996	1997	1998	1999
	%	%	%	%	%	%	%	%	%	%
CO ₂	101.14	100.87	100.87	100.78	100.62	100.68	100.43	100.54	100.46	100.49
CH ₄	100.04	100.03	100.03	100.02	100.01	100.00	100.01	100.01	100.01	100.01
N ₂ O	103.29	102.74	102.90	102.82	102.24	102.00	101.69	101.83	101.90	101.83

GHG	2000	2001	2002	2003	2004	2005	2006	2007	2008	2009
	%	%	%	%	%	%	%	%	%	%
CO ₂	100.45	100.42	100.40	100.30	100.39	100.45	100.46	100.49	100.46	100.36
CH ₄	100.00	100.00	100.00	100.00	100.00	99.94	100.03	100.00	100.00	100.00
N ₂ O	101.89	101.79	101.29	101.24	101.32	101.10	101.31	101.43	102.27	102.25

GHG	2010	2011	2012	2013	2014	2015	2016	2017	2018	2019
	%	%	%	%	%	%	%	%	%	%
CO ₂	100.35	100.39	100.39	100.42	100.41	100.74	100.80	100.63	101.10	101.13
CH ₄	99.95	100.00	100.00	99.94	99.86	99.57	99.67	99.70	99.58	99.48
N ₂ O	102.07	102.63	102.16	101.55	101.14	99.46	99.58	99.90	99.58	100.71

Table 3.2.40 Recalculations for stationary combustion, 2019.

	CO ₂ , kt	CH ₄ , t	N ₂ O t	CO ₂ %	CH ₄ , %	N ₂ O %
1A1 Energy industries	59.75	49.49	3.29	0.71%	1.09%	1.25%
1A1a Public electricity and heat production	23.22	49.05	3.09	0.37%	1.09%	1.30%
1A1b Petroleum refining	0.00	0.00	0.00	0.00%	0.00%	0.00%
1A1c Oil and gas extraction	36.53	0.44	0.20	3.02%	1.24%	0.94%
1A2 Industry	38.23	-65.16	0.92	1.25%	-6.64%	0.59%
1A2a Iron and steel	-0.65	-0.02	0.00	-0.66%	-1.24%	0.08%
1A2b Non-ferrous metals	0.00	0.00	0.00	-	-	-
1A2c Chemicals	-38.75	-14.70	-1.52	-14.35%	-22.79%	-26.39%
1A2d Pulp, paper and print	4.21	2.55	1.89	6.75%	205.42%	176.74%
1A2e Food processing, beverages and tobacco	43.88	-13.23	2.35	4.88%	-2.18%	8.86%
1A2f Non-metallic minerals	21.13	-11.11	4.56	1.43%	-6.31%	5.12%
1A2gviii Other manufacturing industry	8.42	-28.64	-6.37	3.35%	-21.74%	-19.32%
1A4 Other sectors	59.18	-34.86	0.20	2.47%	-0.84%	0.10%
1A4ai Commercial/institutional: Stationary	0.34	-18.96	-0.07	0.06%	-4.96%	-0.40%
1A4bi Residential: Stationary	9.01	0.07	0.06	0.52%	0.00%	0.04%
1A4ci Agriculture/Forestry/Fishing: Stationary	49.83	-15.97	0.21	40.63%	-1.51%	1.78%
Stationary combustion	157.16	-50.53	4.41	1.13%	-0.52%	0.71%

The recalculation of CO₂ emission from stationary combustion is +1.1 % for 1990 and +1.1 % for 2019. The recalculation of CH₄ emission from stationary combustion is +0.013 % for 1990 and -0.52 % for 2019. The recalculation of N₂O emission from stationary combustion is +3.3 % for 1990 and +0.71 % for 2019.

Fuel consumption

For stationary combustion plants, the emission estimates for the years 1990-2019 have been updated according to the latest [energy statistics](#) published by the Danish Energy Agency. The update included both end use and transformation and also a source category update. The changes in the energy statistics are largest for the years 2017, 2018 and 2019. The revisions are shown in the [energy statistics](#). A large number of fuels have been revised including coal, natural gas, wood, fossil waste and biomass waste.

The EU ETS data document a consumption of [gas oil offshore](#) in 2006-2020, whereas the energy statistics do not include this consumption in the offshore sector (DEA, 2021a). According to the EU ETS monitoring plans, gas oil is used

for firewater pumps, generators, emergency generators and cranes. To improve the agreement between CRF and the EU ETS data, the gas oil consumption is now implemented in the sector 1A1c ii Oil and gas extraction in CRF. According to the Danish Energy Agency, the consumption is included in national sea transport in the energy statistics and thus the consumption is subtracted from this sector. The recalculation for stationary combustion (sector 1A1c) is +5.3 kt for 1990 and +36.5 kt for 2019. This corresponds to the recalculations for sector 1A1c.

Revised estimates for combustion of gas-/diesel oil in mobile sources have resulted in revised split between stationary combustion and mobile sources. Further details about the background for the recalculation is included in the mobile combustion chapter. The gas oil reallocated from mobile sources to stationary combustion is +5678 TJ for 1990 corresponding to +421 kt CO₂. For 2019, the recalculation is + 1126 TJ corresponding to 83 kton CO₂. This recalculation is split between industrial plants (1A2) and agricultural plants (1A4c).

Revised estimates for combustion of LPG in mobile sources have resulted in revised split between stationary combustion and mobile sources. Further details about the background for the recalculation is included in the mobile combustion chapter. The LPG reallocated from mobile sources to stationary combustion is +38 TJ for 1990 corresponding to +2.4 kt CO₂. For 2019, the recalculation is -121 TJ corresponding to -7.6 kton CO₂. This recalculation is split between industrial plants (1A2) and agricultural plants (1A4c).

An updated disaggregation to industrial subsectors has been implemented for 2019. In the data reported last year, the disaggregation of the 2019 fuel consumption data were based on fuel consumption data in the industry in 2018. This explains the allocations between subsectors to 1A2 in 2019.

Emission factors

The former CO₂ emission factor for LPG, 63.1 kg/GJ, referred to IPCC Guidelines (2006). According to the latest Key Category Analysis, combustion of LPG is a Key Category and a tier 2 methodology should be applied. Thus, a national reference for the LPG applied in Denmark has been implemented in the emission inventories. The CO₂ emission factor 64.8 kg/GJ is now applied for all years. The emission factor is based on the 93 % propane and 7 % butane. The data are based on data from Danish refineries and Drivkraft Danmark. Further details and references will be included in NIR. The recalculation adds up to between +2.1 kt and +5.1 kt CO₂ for 1990-2019. The recalculation for 1990 is +5.1 kt and for 2019 the recalculation is +3.9 kt. LPG is mainly applied in industrial plants and in residential plants.

The N₂O emission factor for combustion of wood in industrial plants has been revised. A tier 2 emission factor is now applied.

3.2.9 Response to the review process

Report on the individual review of the annual submission of Denmark submitted in 2020, 15 March 2021.

No relevant issues for stationary combustion. Regarding E.6: See NIR 3.4 and Annex 7.

3.2.10 Planned improvements

If possible, a tier 2 emission factor for N₂O from residential wood combustion will be implemented.

3.2.11 References for Chapter 3.2 and Annex 3A

Andersen, M.A. 1996: Elkraft, personal communication letter 07-05-1996.

Astrup, T., Larsen, A.W., Fuglsang, K. & Pedersen, N.H. 2012: PSO-0213, Biogenic Carbon in Danish Combustible Waste. DTU, 2012.

Bruun, J. 2012: Energinet.dk, personal communication, email 03-01-2012.

Christiansen, M., 1996: Elsam, personal communication, letter 07-05-1996.

Danish Energy Agency (DEA), 2003: Data for installation and fuel consumption for each gas engine 1994-2002. Estimated fuel consumption data for gas engines in 1990-1993. Unpublished.

Danish Energy Agency (DEA), 2016: Notat om opdatering af elhandelskorrektion, 2016-04-04. Available at: <https://ens.dk/sites/ens.dk/files/Statistik/elhandelskorrektion.pdf> (2022-01-30).

Danish Energy Agency (DEA), 2021a: The Danish energy statistics, Available at: <https://ens.dk/en/our-services/statistics-data-key-figures-and-energy-maps/annual-and-monthly-statistics> (2022-01-30).

Danish Energy Agency (DEA), 2021b: The Danish energy statistics, Energy Producers Survey (Energiproducenttællingen) 1990-2020. Unpublished.

Danish Energy Agency (DEA), 2021c: The Danish energy statistics, International reporting. Available at: <https://ens.dk/service/statistik-data-noegletal-og-kort/noegletal-og-internationale-indberetninger>.

Danish Energy Agency (DEA), 2020d: Energy statistics data, ENS Tables 2020. Available at: <https://ens.dk/service/statistik-data-noegletal-og-kort/maanedlig-og-aarlig-energistatistik> (2022-01-30).

Danish Energy Agency (DEA), 2021e: e-mail 2021-11-22 from Jane Rusbjerg, Danish Energy Agency.

Danish Environmental Protection Agency (DEPA), 2005: Bekendtgørelse om begrænsning af emission af nitrogenoxider, uforbrændte carbonhydrider og carbonmonoxid mv. fra motorer og turbiner. Bekendtgørelse 621 af 23/06/2005. (Danish legislation). Available at: <https://www.retsinformation.dk/Forms/R0710.aspx?id=12836&exp=1> (2022-01-30).

Danish Environmental Protection Agency (DEPA), 2010b: Bekendtgørelse om visse virksomheders afgivelse af miljøoplysninger. Bekendtgørelse 210 af 03/03/2010. (Danish legislation). Available at: <https://www.retsinformation.dk/Forms/R0710.aspx?id=128761> (2022-01-30).

Danish Environmental Protection Agency (DEPA), 2015: Bekendtgørelse om et register over udledning og overførsel af forurenende stoffer (PRTR). Bekendtgørelse 1172 af 13/10/2015. (Danish legislation). Available at: <https://www.retsinformation.dk/Forms/R0710.aspx?id=174453> (2022-01-30).

Danish Safety Technology Authority, 2012: Danish legislation for gas quality. Bekendtgørelse om gasreglementets afsnit C-12, bestemmelser om gaskvaliteter. Bekendtgørelse 1264 af 14/12/2012, Sikkerhedsstyrelsen. Available at: <https://www.retsinformation.dk/eli/lta/2012/1264> (2022-01-30).

Danish Safety Technology Authority, 2018: Danish legislation for gas quality. Bekendtgørelse om gaskvalitet. Bekendtgørelse nr 230 af 21/03/2018, Sikkerhedsstyrelsen. Available at: <https://www.retsinformation.dk/eli/lta/2018/230> (2022-01-30).

DEPA Waste statistics, 2019: Waste statistics from the Danish Environmental Protection Agency (DEPA), 2021. Available at: <https://mst.dk/affald-jord/affald/affalddatasystemet/find-affalddata/affalddsstatistikker/> (2022-01-30).

Energinet.dk, 2021: SUPPLY OF GAS DURING THE REDEVELOPMENT OF THE TYRA PLATFORM. Available at: <https://en.energinet.dk/Gas/Tyra> (2022-01-30).

EU Commission, 2018: REGULATIONS, COMMISSION IMPLEMENTING REGULATION (EU) 2018/2066 of 19 December 2018 on the monitoring and reporting of greenhouse gas emissions pursuant to Directive 2003/87/EC of the European Parliament and of the Council and amending Commission Regulation (EU) No 601/2012 Available at: <https://eur-lex.europa.eu/legal-content/EN/TXT/PDF/?uri=CELEX:32018R2066&from=EN> (2022-01-30).

European Environment Agency (EEA), 2019: EMEP/EEA air pollutant emission inventory guidebook 2019. Available at: <https://www.eea.europa.eu/publications/emep-eea-guidebook-2019> (2022-01-30).

Fausser, P., Nielsen, M., Winther, M., Plejdrup, M., Gyldenkerne, S., Mikkelsen, M.H., Albrektsen, R., Hoffmann, L., Thomsen, M., Hjelgaard, K. & Nielsen, O.-K. 2013. Verification of the Danish 1990, 2000 and 2010 emission inventory data. Aarhus University, DCE – Danish Centre for Environment and Energy, 85 pp. Scientific Report from DCE – Danish Centre for Environment and Energy No. 79. V Available at: <http://dce2.au.dk/pub/SR79.pdf> (2022-01-30).

Fellner, J. & Rechberger, H. 2010: Biomass Content in the Waste Feed of Danish Waste-to-energy Plant, TU Wien, 2010. (Enclosed as Annex 10 in Astrup et al., 2012).

Fenhann, J. & Kilde, N.A. 1994: Inventory of Emissions to the air from Danish Sources 1972-1992, RISØ.

Henriksen, 2005: e-mail from Arne Henriksen, Elsam Engineering, 2005-08-11. Unpublished emission measurement data for N₂O from 3 power plants combusting coal.

IPCC, 2000: Penman, J., Kruger, D., Galbally, I., Hiraiishi, T., Nyenzi, B., Emmanuel, S., Buendia, L., Hoppaus, R., Martinsen, T., Meijer, J., Miwa, K. & Tanabe, K. (Eds). Good Practice Guidance and Uncertainty Management in National Greenhouse Gas Inventories. Published: IPCC/OECD/IEA/IGES, Hayama, Japan. Available at:
<http://www.ipcc-nggip.iges.or.jp/public/gp/english/index.html> (2022-01-30).

IPCC, 2006: Revised 2006 IPCC Guidelines for National Greenhouse Gas Inventories: Available at:
<http://www.ipcc-nggip.iges.or.jp/public/2006gl/index.html> (2022-01-30).

Jensen, B.G. & Lindroth, M. 2002: Kontrol af indberetning af CO₂-udledning fra el-producenter i 2001, Carl Bro for Energistyrelsens 6. Kontor (in Danish).

Jeppesen, J.S. 2007: København energi (Copenhagen Energy), Jørgen Steen Jeppesen, personal communication.

Johansson, L.S., Leckner, B., Gustavsson, L., Cooper, D., Tullin, C. & Potter, A. 2004: Emission characteristics of modern and old-type residential boilers fired with wood logs and wood pellets, Atmospheric Environment 38 (2004) 4183-4195.

Juhrich, 2016: CO₂ Emission Factors for Fossil Fuels, Umwelt Bundesamt, CLIMATE CHANGE 28/2016. Available at:
https://www.umweltbundesamt.de/sites/default/files/medien/1968/publikationen/co2_emission_factors_for_fossil_fuels_correction.pdf (2022-01-30).

Jørgensen, L., Andersen, S. D., Lovett, D. M. & Kristensen, P. G., 2010: Emissionskortlægning for decentral kraftvarme 2007, Måleprogram og analyse af emissioner fra gas- og oliefyrede decentrale kraftvarmeanlæg < 25 MW_e. Danish Gas Technology Centre. Available at:
https://www.dgc.dk/sites/default/files/filer/publikationer/R1007_emissionskortlaegning_decentral_KV.pdf (2022-01-30).

Kjellander, 2021: emails correspondence from Patrik Kjellander, Shell, 22-04-2021 to 11-05-2021.

Københavns Energi (KE), 2015: Københavns energi (Copenhagen Energy) fact sheet on town gas.

Kristensen, P.G. 2007: Danish Gas Technology Centre, Per Gravers Kristensen, email 2007-04-19.

Kristensen, P.G. 2010: Danish Gas Technology Centre, Per Gravers Kristensen, email 2010-02-10.

Kristensen, P.G. 2015a: Personal communication concerning biogas, e-mail 26-03-2014, Danish Gas Technology Centre.

Kristensen, P.G. 2015b: Personal communication concerning bio natural gas, email 11-11-2015, Danish Gas Technology Centre.

Lindgren, 2010: Energinet.dk, Tine Lindgren, email 2010-03-16.

Nielsen, M. & Wit, J. 1997: Emissionsforhold for gasdrevne kraftvarmeanlæg < 25MW_e, Miljøstyrelsen, Arbejdsrapport Nr. 17 1997 (In Danish). Available at:

<http://www2.mst.dk/Udgiv/publikationer/1997/87-7810-759-8/pdf/87-7810-759-8.pdf> (2022-01-30).

Nielsen, M. & Illerup, J.B. 2003: Emissionsfaktorer og emissionsopgørelse for decentral kraftvarme. Eltra PSO projekt 3141. Kortlægning af emissioner fra decentrale kraftvarmeværker. Delrapport 6. Danmarks Miljøundersøgelser. 116 s. –Faglig rapport fra DMU nr. 442. (In Danish, with an English summary). Available at: https://www.dmu.dk/1_viden/2_publicationer/3_fagrappporter/rapporter/FR442.pdf (2022-01-30).

Nielsen, M. & Illerup, J.B. 2004: Danish emission inventories for stationary combustion plants. Inventories until year 2002. National Environmental Research Institute, Denmark. 127pp. – Research Notes from NERI no. 200. Available at:

http://www2.dmu.dk/1_viden/2_Publicationer/3_arbrappporter/rapporter/AR200.pdf (2022-01-30).

Nielsen, M. & Illerup, J.B. 2006: Danish emission inventories for stationary combustion plants. Inventories until year 2003. National Environmental Research Institute, Denmark. 162 pp. – Research Notes from NERI no. 229. Available at:

http://www2.dmu.dk/1_viden/2_Publicationer/3_arbrappporter/rapporter/AR229.pdf (2022-01-30).

Nielsen, O.-K., Nielsen, M. & Illerup, J.B. 2007: Danish Emission Inventories for Stationary Combustion Plants. Inventories until year 2004. National Environmental Research Institute, University of Aarhus, Denmark. 176 pp. – NERI Technical Report no. 628. Available at:

http://www2.dmu.dk/Pub/FR628_Final.pdf (2022-01-30).

Nielsen, M., Illerup, J.B. & Birr-Petersen, K., 2008: Revised emission factors for gas engines including start/stop emissions. Sub-report 3 (NERI). National Environmental Research Institute, University of Aarhus. 69 pp. - NERI Technical Report No. 672. Available at:

<http://www2.dmu.dk/Pub/FR672.pdf> (2022-01-30).

Nielsen, M., Nielsen, O.-K., Plejdrup, M. & Hjelgaard, K., 2009: Danish Emission Inventories for Stationary Combustion Plants. Inventories until year 2007. National Environmental Research Institute, Aarhus University, Denmark. 216 pp. – NERI Technical Report no. 744. Available at:

<http://www2.dmu.dk/Pub/FR744.pdf> (2022-01-30).

Nielsen, M., Nielsen, O.-K. & Thomsen, M. 2010a: Emissions from decentralised CHP plants 2007 - Energinet.dk Environmental project no. 07/1882. Project report 5 – Emission factors and emission inventory for decentralised CHP production. National Environmental Research Institute, Aarhus University. 113 pp. – NERI Technical report No. 786. Available at: <http://www.dmu.dk/Pub/FR786.pdf> (2022-01-30).

Nielsen, M., Nielsen, O.-K., Plejdrup, M. & Hjelgaard, K., 2010b: Danish Emission Inventories for Stationary Combustion Plants. Inventories until 2008. National Environmental Research Institute, Aarhus University, Denmark. 236 pp. – NERI Technical Report No. 795. Available at: <http://www.dmu.dk/Pub/FR795.pdf> (2022-01-30).

Nielsen, M., Nielsen, O.-K. & Plejdrup, M., 2014: Danish Emission Inventories for Stationary Combustion Plants. Inventories until 2011. Aarhus University, DCE – Danish Centre for Environment and Energy. Available at: <http://dce2.au.dk/pub/SR102.pdf> (2022-01-30).

Nielsen, M., Nielsen, O.-K. & Plejdrup, M.S. 2018. Danish emission inventories for stationary combustion plants. Inventories until 2015. Aarhus University, DCE – Danish Centre for Environment and Energy, 324 pp. Scientific Report from DCE – Danish Centre for Environment and Energy No. 279 <http://dce2.au.dk/pub/SR279.pdf> (2022-01-30).

Nielsen, O.-K., Plejdrup, M.S., Winther, M., Gyldenkærne, S., Thomsen, M., Nielsen, M., Mikkelsen, M.H., Albrektsen, R., Hjelgaard, K. & Bruun, H.G. 2020. Quality manual for the Danish greenhouse gas inventory. Version 3. Aarhus University, DCE – Danish Centre for Environment and Energy, 44 pp. Scientific Report No. 406, Available at: <http://dce2.au.dk/pub/SR406.pdf> (2022-01-30).

Nielsen, O.-K., Nielsen, M. & Plejdrup, M.S., 2021. Updating the emission model for residential wood combustion. Aarhus University, DCE – Danish Centre for Environment and Energy. Available at: <https://dce2.au.dk/pub/SR442.pdf> (2022-01-30).

Nielsen, M. 2021. Danish emission inventories for stationary combustion plants. Inventories until 2018. Aarhus University, DCE – Danish Centre for Environment and Energy, 280 pp. Scientific Report No. 424. Available at: <http://dce2.au.dk/pub/SR424.pdf> (2022-01-30).

Nielsen, O.-K., Plejdrup, M.S., Winther, M., Mikkelsen, M.H., Nielsen, M., Gyldenkærne, S., Fauser, P., Albrektsen, R., Hjelgaard, K., Bruun, H.G. & Thomsen, M. 2022. Annual Danish Informative Inventory Report to UNECE. Emission inventories from the base year of the protocols to year 2020. Aarhus University, DCE – Danish Centre for Environment and Energy. Scientific Report from DCE – Danish Centre for Environment and Energy. Will be available at the AU homepage in 2022.

NIR Germany 2021: Submission under the United Nations Framework Convention on Climate Change and the Kyoto Protocol 2021, National Inventory Report for the German Greenhouse Gas Inventory 1990 – 2019, Federal Environment Agency, UNFCCC Submission 15 April 2021.

NIR Netherlands, 2021: Greenhouse gas emissions in the Netherlands 1990–2019, National Inventory Report 2021, 15 April 2021.

NIR Norway, 2021: Greenhouse Gas Emissions 1990–2019, National Inventory Report.

NIR Sweden, 2021: National Inventory Report Sweden 2021, Greenhouse Gas Emission Inventories 1990-2019 Submitted under the United Nations Framework Convention on Climate Change and the Kyoto Protocol.

Olsson, M. & Kjällstrand, J. 2005: Low emissions from wood burning in an ecolabelled residential boiler, *Atmospheric Environment* 40 (2006) 1148-1158.

Paulrud, S., Kindbom, K., Cooper, K. & Gustafsson, T., 2005: Methane emissions from residential biomass combustion, SMED report 2005-10-14, IVL Swedish Environmental Research Institute and SCB, Statistics Sweden SMHI. Assignment for Swedish Environmental Protection Agency.

Rosvall, 2021: email correspondence from Anne Sig Rosvall, Drivkraft Danmark, 16-04-2021 to 21-04-2021.

Rusbjerg, 2021: email from Jane Rusbjerg, Danish Energy Agency 30-07-2021.

Tønder, 2021: email correspondence from Søren Tønder, Primagaz, 06-05-2021.

Zarnaghi, 2021: email from Ali Zarnaghi, Danish Energy Agency, 01-09-2021.

3.3 Transport and other mobile sources

The emission inventory basis for mobile sources is fuel consumption information from the Danish energy statistics. In addition, background data for road transport (fleet and mileage), air traffic (aircraft type, flight numbers, origin and destination airports), national sea transport (fuel surveys, ferry technical data, number of return trips, sailing time) and non-road machinery (engine no., engine size, load factor and annual working hours) are used to make the emission estimates sufficiently detailed. Emission data mainly comes from the EMEP/EEA Air Pollutant Emission Inventory Guidebook (EMEP/EEA, 2019). However, for railways, measurements specific to Denmark are used.

In the Danish emissions database, all activity rates and emissions are defined in SNAP sector categories (Selected Nomenclature for Air Pollution) according to the CORINAIR system. The emission inventories are prepared from a complete emission database based on the SNAP sectors. The aggregation to the sector codes used for both the UNFCCC and UNECE Conventions is based on a correspondence list between SNAP and IPCC classification codes (CRF), shown in Table 3.3.1 (mobile sources only).

Table 3.3.1 SNAP – CRF correspondence table for transport.

SNAP classification	CRF/NFR classification
0701 Road traffic: Passenger cars	1A3bi Road transport: Passenger cars
0702 Road traffic: Light duty vehicles	1A3bii Road transport: Light duty vehicles
0703 Road traffic: Heavy duty vehicles	1A3biii Road transport: Heavy duty vehicles
0704/0705 Road traffic: Mopeds and motor cycles	1A3biv Road transport: Mopeds & motorcycles
0706 Road traffic: Evaporation	1A3bv Road transport: Evaporation
0707 Road traffic: Brake and tire wear	1A3bvi Road transport: Brake and tire wear
0708 Road traffic: Road abrasion	1A3bvii Road transport: Road abrasion
0801 Military	1A5b Other, Mobile
0802 Railways	1A3c Railways
0803 Inland waterways	1A5b Other, Mobile
080402 National sea traffic	1A3dii National navigation (Shipping)
080403 National fishing	1A4ciii Agriculture/Forestry/Fishing: National fishing
080404 International sea traffic	1A3di (i) International navigation (Shipping)
080501 Dom. airport traffic (LTO < 1000 m)	1A3aii (i) Civil aviation (Domestic, LTO)
080502 Int. airport traffic (LTO < 1000 m)	1A3ai (i) Civil aviation (International, LTO)
080503 Dom. cruise traffic (> 1000 m)	1A3aii (ii) Civil aviation (Domestic, Cruise)
080504 Int. cruise traffic (> 1000 m)	1A3ai (ii) Civil aviation (International, Cruise)
0806 Agriculture	1A4cii Agriculture/Forestry/Fishing: Off-road agriculture/forestry
0807 Forestry	1A4cii Agriculture/Forestry/Fishing: Off-road agriculture/forestry
0808 Industry	1A2gvii Manufacturing industries/Construction (mobile)
0809 Household and gardening	1A4bii Residential: Household and gardening (mobile)
0811 Commercial and institutional	1A4aii Commercial/Institutional: Mobile

Military transport activities (land and air) refer to the CRF/NFR sector Other (1A5), the latter sector also including recreational craft (SNAP code 0803).

Road traffic evaporation, brake and tire wear, and road abrasion (SNAP codes 0706-0708) is not a part of the CRF list since no greenhouse gases are emitted from these sources.

Emissions from lubricants during use are reported under 2D3 as per the UN-FCCC reporting guidelines. Two-stroke engines in road transport are only relevant for mopeds and motorcycles (and the odd veteran vehicle) and even in these categories four-stroke engines have gained popularity in part due to environmental considerations. The Danish energy statistics only include lubricants for non-energy purposes and any consumption in two-stroke mopeds/motorcycles will be negligible and fall far below the threshold of significance.

For aviation, LTO (Landing and Take Off)¹ refers to the part of flying which is below 1000 m. This part of the aviation emissions (SNAP codes 080501 and 080502) are included in the national emissions total as prescribed by the UNECE reporting rules. According to UNFCCC, the national emissions for aviation comprise the emissions from domestic LTO (080501) and domestic cruise (080503). The fuel consumption and emission development explained in the following are based on these latter results.

¹A LTO cycle consists of the flying modes approach/descent, taxiing, take off and climb out. In principle, the actual times-in-modes rely on the actual traffic circumstances, the airport configuration, and the aircraft type in question.

Agricultural and forestry non-road machinery (SNAP codes 0806 and 0807) is accounted for in the Agriculture/forestry (1A4cii) sector. Fishing activities (SNAP code 080403) regardless of vessel flag is reported under 1A4ciii.

For mobile sources, internal database models for road transport, air traffic, sea transport and non-road machinery have been set up at DCE, Aarhus University, in order to produce the emission inventories. The output results from the DCE models are calculated in a SNAP format, as activity rates (fuel consumption) and emission factors, which are then exported directly to the central Danish CollectER database.

Apart from national inventories, the DCE models are used also as a calculation tool in research projects, environmental impact assessment studies, and to produce basic emission information, which requires various aggregation levels.

A Key Category Analysis (KCA) approach 1 and approach 2 for the years 1990 and 2020 and for the trend 1990-2020 for Denmark has been carried out in accordance with the IPCC Guidelines (IPCC, 2006). Table 3.3.2 shows the 12 mobile source categories. The table is based on the analysis including LU-LUCF. The full key category analysis for Denmark is shown in NIR Chapter 1.5 and Annex 1.

Mobile sources include quite many key categories in the case of CO₂. Most notably, road transport and non-road mobile machinery in industry and agriculture are key sources in 1990 and 2020 and for the emission trend in both the approach 1 and approach 2 analysis. CH₄ is not a key category in any case for mobile sources. Finally, due to the relatively high uncertainty for N₂O, emission factors the N₂O emission from a few emission sources are also key categories in the approach 2 analysis.

Table 3.3.2 Key category overview², mobile sources.

		Approach 1			Approach 2		
		1990	2020	1990-2020	1990	2020	1990-2020
1.A.2.g Industry (mobile)	CO ₂	Level	Level	Trend	Level	Level	Trend
1.A.3.a Civil aviation	CO ₂	Level					
1.A.3.b Road Transport	CO ₂	Level	Level	Trend	Level	Level	Trend
1.A.3.c Railways	CO ₂	Level	Level				
1.A.3.d Navigation (large vessels)	CO ₂	Level	Level				
1.A.4.a Commercial/Institutional (mobile)	CO ₂		Level	Trend			Trend
1.A.4.b Residential (mobile)	CO ₂						
1.A.4.c ii Agriculture (mobile)	CO ₂	Level	Level	Trend	Level	Level	Trend
1.A.4.c ii Forestry (mobile)	CO ₂						
1.A.4.c iii Fisheries	CO ₂	Level	Level	Trend			
1.A.5.b Other (military)	CO ₂						
1.A.5.b Other (small boats)	CO ₂		Level				
1.A.2.g Industry (mobile)	CH ₄						
1.A.3.a Civil aviation	CH ₄						
1.A.3.b Road Transport	CH ₄						
1.A.3.c Railways	CH ₄						
1.A.3.d Navigation (large vessels)	CH ₄						
1.A.4.a Commercial/Institutional (mobile)	CH ₄						
1.A.4.b Residential (mobile)	CH ₄						
1.A.4.c ii Agriculture (mobile)	CH ₄						
1.A.4.c ii Forestry (mobile)	CH ₄						
1.A.4.c iii Fisheries	CH ₄						
1.A.5.b Other (military)	CH ₄						
1.A.5.b Other (small boats)	CH ₄						
1.A.2.g Industry (mobile)	N ₂ O						Trend
1.A.3.a Civil aviation	N ₂ O						
1.A.3.b Road Transport	N ₂ O		Level				
1.A.3.c Railways	N ₂ O						
1.A.3.d Navigation (large vessels)	N ₂ O						
1.A.4.a Commercial/Institutional (mobile)	N ₂ O						
1.A.4.b Residential (mobile)	N ₂ O						
1.A.4.c ii Agriculture (mobile)	N ₂ O					Level	Trend
1.A.4.c ii Forestry (mobile)	N ₂ O						
1.A.4.c iii Fisheries	N ₂ O						
1.A.5.b Other (military)	N ₂ O						

3.3.1 Source category description

The following description of source categories explains the development in fuel consumption and emissions for road transport and other mobile sources.

Fuel consumption

Table 3.3.3 shows the fuel consumption for domestic transport based on DEA statistics for 2020 in CRF sectors (DEA, 2021a). The fuel consumption figures in time series 1985-2020 are given in Annex 2.B.16 (CRF format) and are shown for 2020 in Annex 2.B.15 (CollectER format). Road transport has a major share of the fuel consumption for domestic transport. In 2020, this sector's fuel consumption share is 81 %, while the fuel consumption shares for Off road agriculture/forestry, Manufacturing industries (mobile) and National navigation

² For Denmark, not including Greenland & Faroe Island. Based on the KCA including LULUCF.

are 6 %, 4 % and 3 %, respectively. For the remaining sectors, the total fuel consumption share is 6 %.

Table 3.3.3 Fuel consumption (PJ) for domestic transport in 2020 in CRF sectors.

CRF ID	Fuel consumption (PJ)
Manufacturing industries/Construction (mobile)	7.4
Civil aviation (Domestic)	1.1
Road transport: Passenger cars	87.0
Road transport: Light duty vehicles	21.3
Road transport: Heavy duty vehicles	51.8
Road transport: Mopeds & motorcycles	1.0
Railways	2.7
National navigation (Shipping)	6.4
Commercial/Institutional: Mobile	2.8
Residential: Household and gardening (mobile)	0.3
Agriculture/Forestry/Fishing: Off-road agriculture/forestry	11.6
Agriculture/Forestry/Fishing: National fishing	3.6
Other. Mobile	3.3
Road transport total	161.2
Other mobile total	39.1
Domestic total	200.3
Civil aviation (International)	13.6
Navigation (international)	21.5

From 1990 to 2020, diesel (sum of diesel and biodiesel) and gasoline (sum of neat gasoline and bio ethanol) fuel consumption has changed by 47 % and -23 %, respectively (Figure 3.3.1), and in 2020 the fuel consumption shares for diesel and gasoline were 71 % and 27 %, respectively (not shown). Other fuels only have a 2 % share of the domestic transport total (Figures 3.3.2). Almost all gasoline is used in road transportation vehicles. Gardening machinery and recreational craft are merely small consumers. Regarding diesel, there is considerable fuel consumption in most of the domestic transport categories, whereas a more limited use of residual oil and jet fuel is being used in the navigation sector and by aviation (civil and military flights), respectively³.

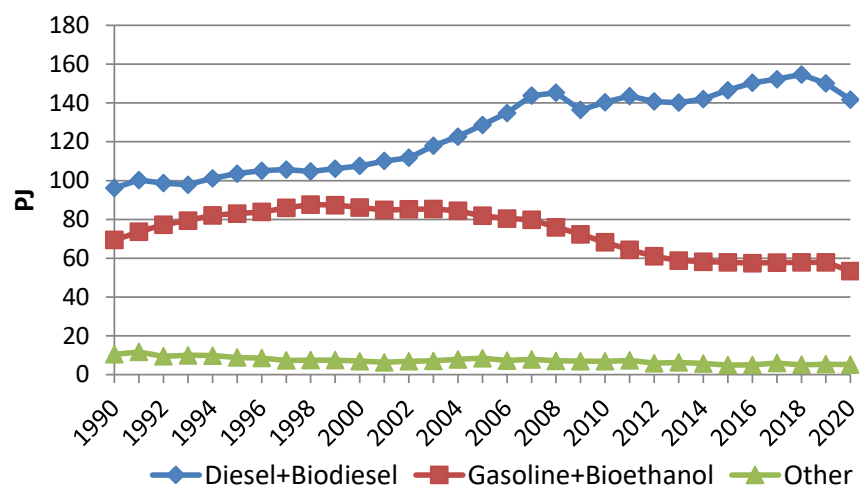

Figure 3.3.1 Fuel consumption per fuel type for domestic transport 1990-2020.

³ Biofuels are sold at gas filling stations and assumed used by road transport vehicles.

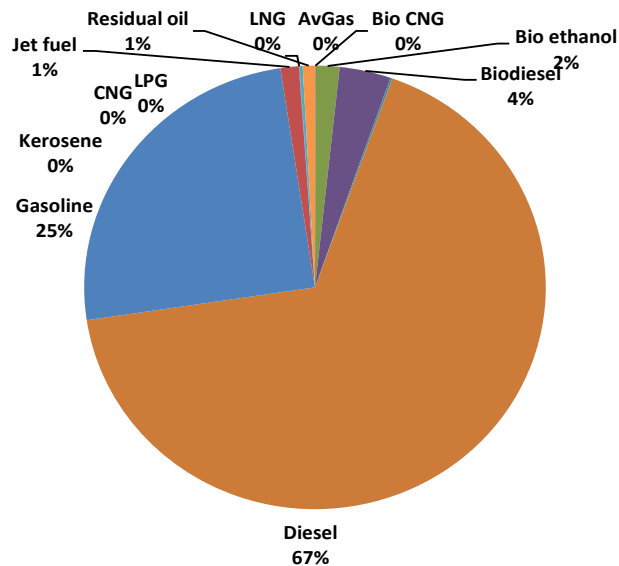

Figure 3.3.2 Fuel consumption share per fuel type for domestic transport in 2020.

Road transport

As shown in Figure 3.3.3, the fuel consumption for road transport⁴ has generally increased until 2007, except from a small fuel consumption decline noted in 2000. Significant fuel consumption declines are noted for 2008- 2009 and in 2020, respectively, due to the global financial crisis and Covid 19 social restrictions. The fuel consumption development is due to a decreasing trend in the use of gasoline fuels from 1999 to 2013 combined with a steady growth in the use of diesel until 2007, and from 2014 to 2018. Within sub-sectors, passenger cars represent the most fuel-consuming vehicle category, followed by heavy-duty vehicles, light duty vehicles and 2-wheelers, in decreasing order (Figure 3.3.4).

⁴ The sum share of bioethanol and biodiesel in the gasoline and diesel fuel blends for road transport is 5.4 %, in 2020.

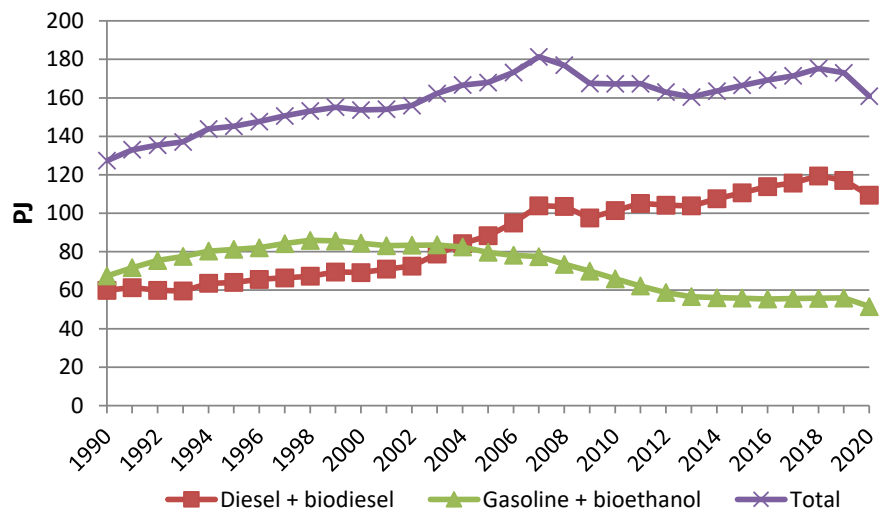
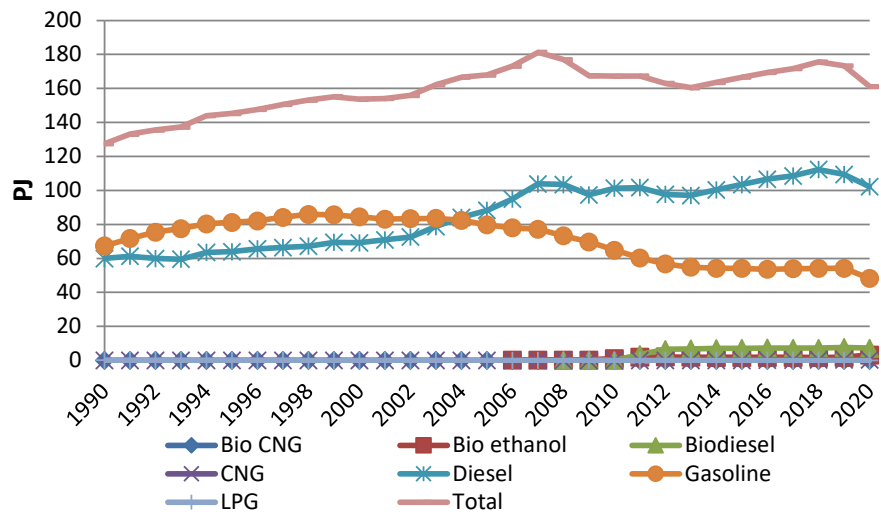

Figure 3.3.3 Fuel consumption per fuel type and as totals for road transport 1990-2020.

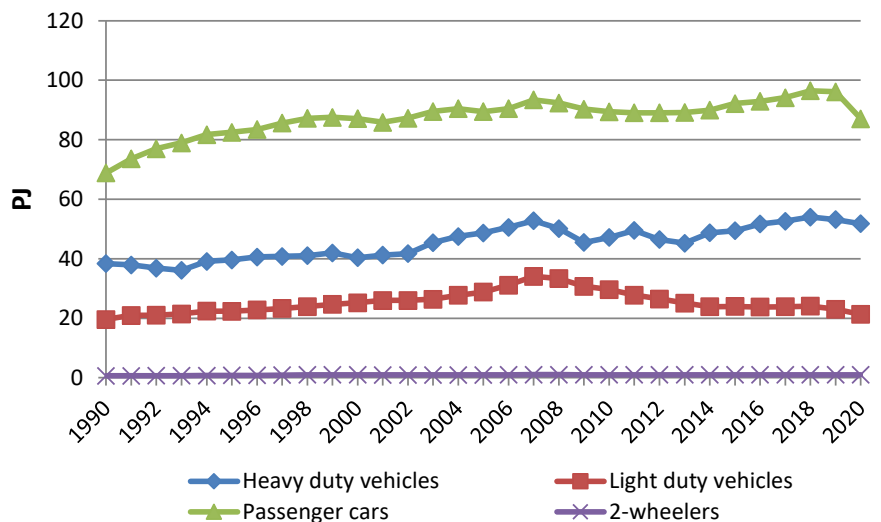

Figure 3.3.4 Total fuel consumption per vehicle type for road transport 1990-2020.

As shown in Figure 3.3.5, fuel consumption for gasoline passenger cars dominates the overall gasoline consumption trend. The development in diesel fuel consumption in recent years (Figure 3.3.6) is characterised by increasing fuel consumption for diesel passenger cars until 2018, while declines in the fuel

consumption for trucks and buses (heavy-duty vehicles) are noted for 2008-2009, 2012-2013 and 2019-2020, and fuel consumption reductions for light duty vehicles are noted for 2008-2014 and 2019-2020.

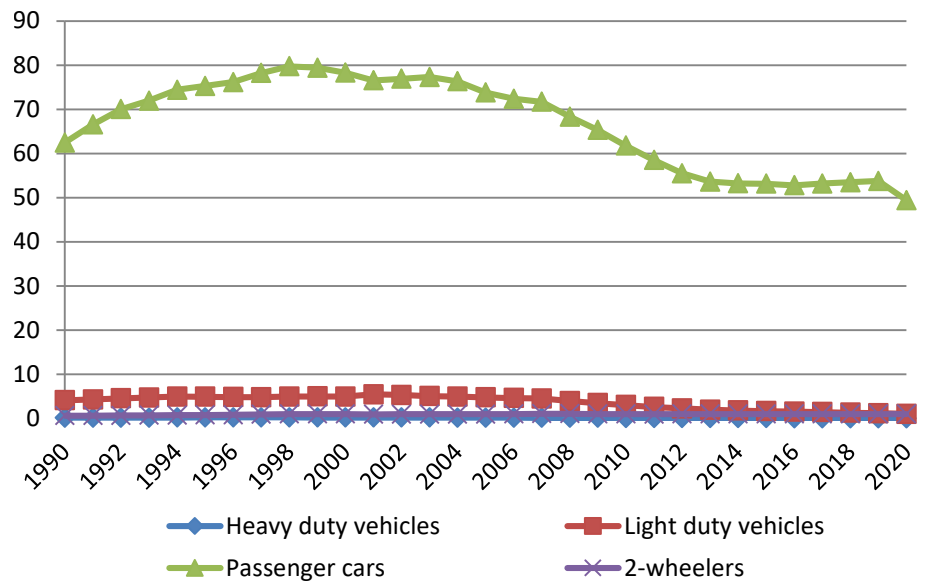

Figure 3.3.5 Gasoline fuel consumption per vehicle type for road transport 1990-2020.

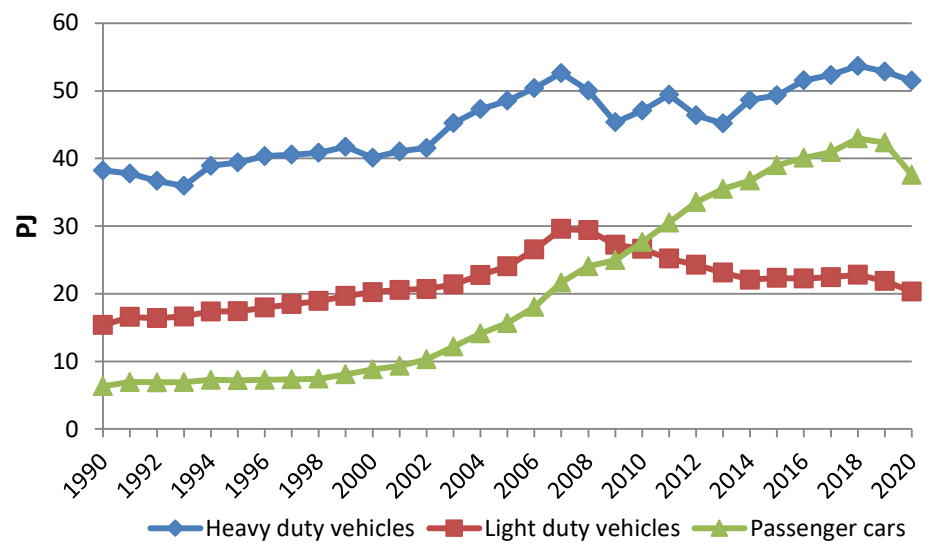

Figure 3.3.6 Diesel fuel consumption per vehicle type for road transport 1990-2020.

In 2020, fuel consumption shares for gasoline passenger cars, diesel heavy-duty vehicles, diesel passenger cars and diesel light duty vehicles and gasoline light duty vehicles were 31, 32, 23 and 12 %, respectively (Figure 3.3.7).

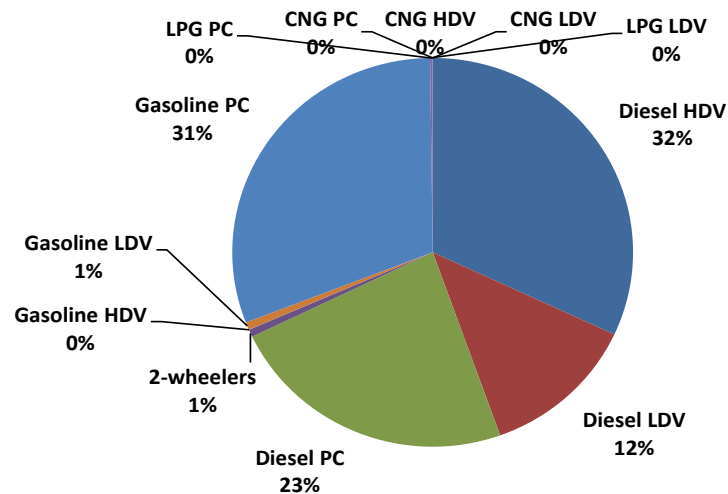

Figure 3.3.7 Fuel consumption share (PJ) per vehicle type for road transport in 2020.

Other mobile sources

It must be noted that the fuel consumption figures behind the Danish inventory for mobile equipment in the agriculture, forestry, industry, household and gardening (residential), and inland waterways (part of navigation) sectors, are less certain than for other mobile sectors. For these types of machinery, the DEA statistical figures do not directly provide fuel consumption information, and fuel consumption totals are subsequently estimated from activity data and fuel consumption factors. For recreational craft the latest historical year is 2004.

As seen in Figure 3.3.8, classified according to CRF the most important sectors are Agriculture/forestry/fisheries (1A4c), Industry-other (mobile machinery part of 1A2g) and Navigation (1A3d). Minor fuel consuming sectors are Civil Aviation (1A3a), Railways (1A3c), Other (military mobile and recreational craft: 1A5b), Commercial/institutional (1A4a) and Residential (1A4b).

The 1990-2020 time series are shown per fuel type in Figures 3.3.9-3.3.12 for diesel, gasoline, residual oil and jet fuel, respectively.

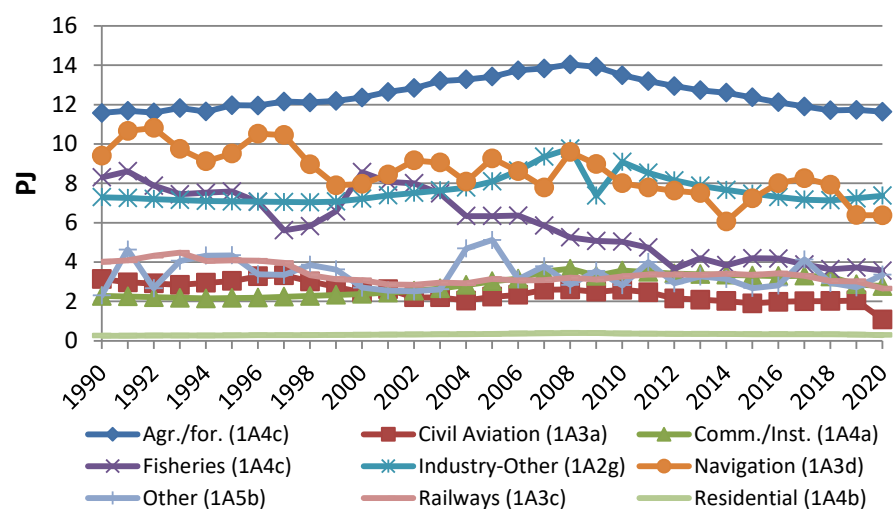

Figure 3.3.8 Total fuel consumption in CRF sectors for other mobile sources 1990-2020.

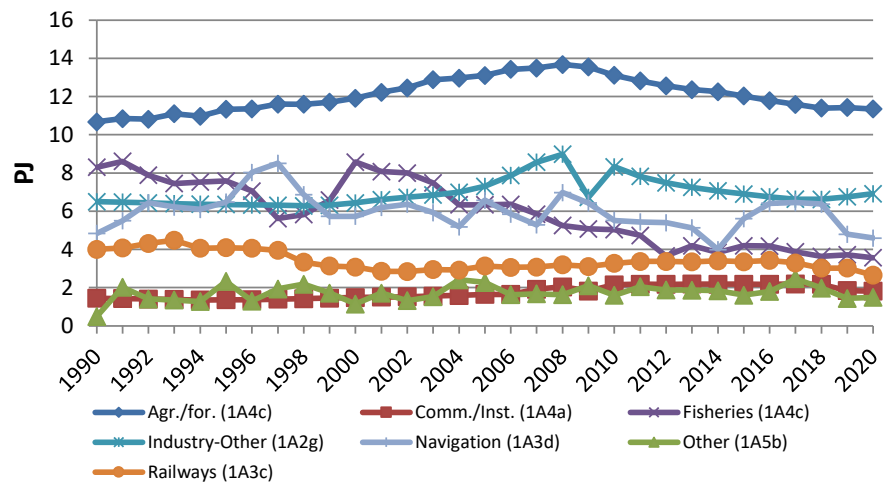

Figure 3.3.9 Diesel fuel consumption in CRF sectors for other mobile sources 1990-2020.

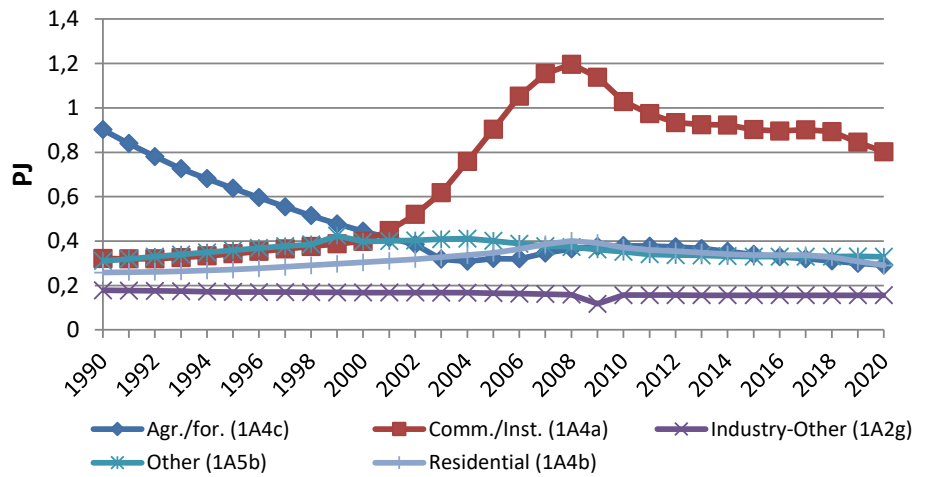

Figure 3.3.10 Gasoline fuel consumption in CRF sectors for other mobile source 1990-2020.

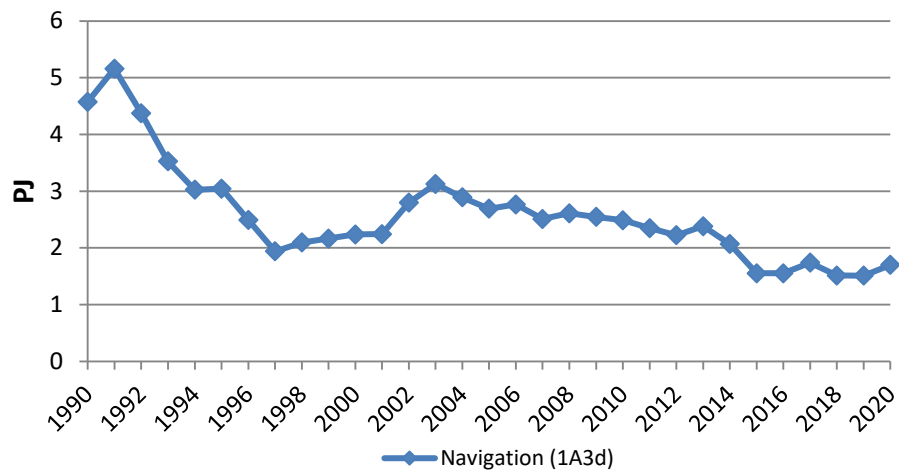

Figure 3.3.11 Residual oil fuel consumption in CRF sectors for other mobile sources 1990-2020.

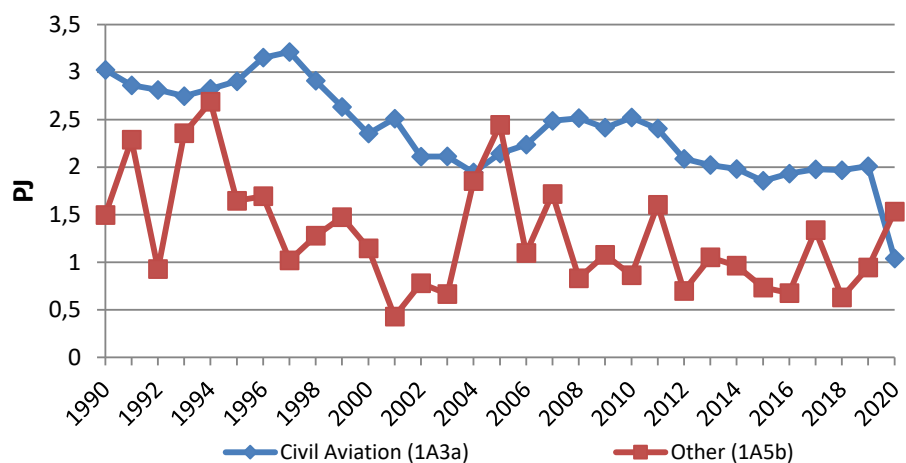

Figure 3.3.12 Jet fuel consumption in CRF sectors for other mobile sources 1990-2020.

For diesel, although the number of tractors and harvesters decrease in the entire period 1985-2020, the contemporary increase in the engine sizes of new sold machines makes the total fuel consumption grow until 2008. The turnover of old less fuel efficient machinery and the decline in the number of tractors and harvesters explain the total fuel consumption decrease from 2008 onwards. The fuel consumption for industry has increased from the beginning of the 1990's, due to an increase in the activities for construction machinery. The fuel consumption increase has been very pronounced in 2005-2008, for 2009; however, the global financial crisis has a significant impact on the building and construction activities. The fuel efficiency improvements for new sold vehicles is the main reason for total fuel consumption decline from 2010-2018. For fisheries, the development in fuel consumption reflects the activities in this sector.

The Navigation sector comprises national sea transport (fuel consumption between two Danish ports including sea travel directly between Denmark and Greenland/Faroe Islands). For national sea transport, the diesel fuel consumption curve reflects the combination of traffic and ferries in use for regional ferries. In 1998 and 1999, a significant decline in fuel consumption is apparent. The most important explanation here is the closing of ferry service routes in connection with the opening of the Great Belt Bridge in 1997. For railways, the gradual shift towards electrification explains the lowering trend in diesel fuel consumption and the emissions for this transport sector. The fuel consumed (and associated emissions) to produce electricity is accounted for in the stationary combustion part of the Danish inventories.

The largest gasoline fuel consumption is calculated for the Commercial/Institutional (1A4a) sector related to the use of household and gardening machinery. For these types of machinery, a somewhat smaller gasoline fuel consumption is calculated for the Residential (1A4b) sector. For household and gardening equipment, especially from 2001-2006, a significant fuel consumption increase is apparent due to considerable growth in the machinery stock. The gasoline fuel consumption development for Agriculture/forestry/fisheries (1A4c) is due to the gradual phasing out of gasoline-fuelled agricultural tractors until 2005 and the gradual increase in new sales of ATV's from the mid 2000's until 2011, followed by a decrease in new sales of ATV's from 2011 forward.

In terms of residual oil, there has been a substantial decrease in the fuel consumption for regional ferries. The fuel consumption decline is most significant from 1991-1994 and from 1995-1997.

The considerable variations from one year to another in military jet fuel consumption are due to planning and budgetary reasons, and the passing demand for flying activities. Consequently, for some years, a certain amount of jet fuel stock-building might disturb the real picture of aircraft fuel consumption. Civil aviation has decreased until 2004, since the opening of the Great Belt Bridge in 1997, both in terms of number of flights and total jet fuel consumption. From 2011 to 2012, the total consumption of jet fuel decreased significantly due to a drop in the number of domestic flights, and in 2020 a huge decline in jet fuel consumption is noted due to the impact of Covid 19 on flight travel demand.

Fuel consumption for international transport

The residual oil and diesel oil fuel consumption fluctuations reflect the quantity of fuel sold in Denmark to international ferries, international warships, other ships with foreign destinations, tank vessels and foreign fishing boats. For jet petrol, the sudden fuel consumption drop in 2002 is explained by the recession in the aviation sector due to the events of September 11, 2001 and structural changes in the aviation business. In 2009, the impact of the global financial crisis on flying activities becomes very visible, and in 2020 a huge decline in jet fuel consumption is noted due to the impact of Covid 19 on flight travel demand.

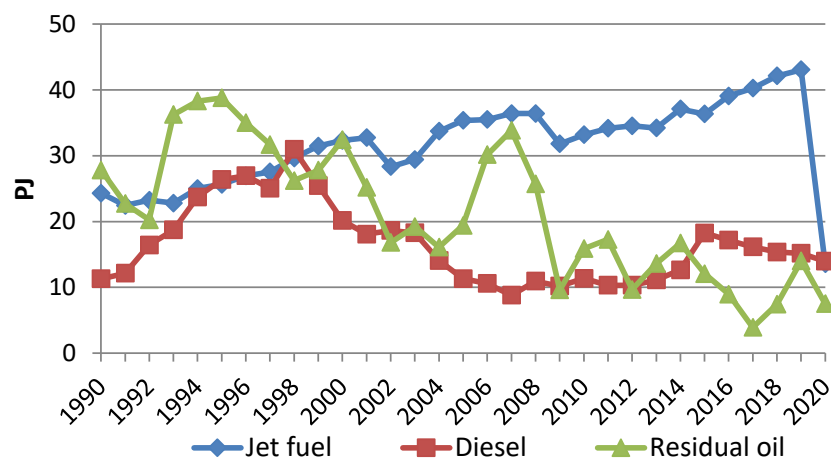

Figure 3.3.13 Bunker fuel consumption 1990-2020.

Emissions of CO₂, CH₄ and N₂O

In Table 3.3.4 the CO₂, CH₄ and N₂O emissions for road transport and other mobile sources are shown for 2020 in CRF sectors. The emission figures in time series 1990-2020 are given in Annex 3.B.16 (CRF format) and are shown for 1990 and 2020 in Annex 3.B.15 (CollectER format).

From 1990 to 2020, the road transport emissions of CO₂ and N₂O have increased by 19 and 42 %, respectively, whereas the emissions of CH₄ have decreased by 90 % (from Figures 3.3.14 - 3.3.16). From 1990 to 2020 the other mobile CO₂ emissions have decreased by 20 %, (from Figures 3.3.18 - 3.3.20).

Table 3.3.4 Emissions of CO₂, CH₄ and N₂O in 2020 for road transport and other mobile sources.

	CO ₂ ktonnes	CH ₄ tonnes	N ₂ O tonnes
Manufacturing industries/Construction (mobile)	542	15	25
Civil aviation (Domestic)	78	1	4
Road transport: Passenger cars	5996	197	134
Road transport: Light duty vehicles	1482	6	43
Road transport: Heavy duty vehicles	3594	41	238
Road transport: Mopeds & motorcycles	69	72	1
Railways	197	3	6
National navigation (Shipping)	478	32	12
Commercial/Institutional: Mobile	199	30	8
Residential: Household and gardening (mobile)	20	15	0
Agriculture/Forestry/Fishing: Off-road agriculture/forestry	861	52	41
Agriculture/Forestry/Fishing: National fishing	264	6	6
Other, Mobile	243	10	9
Road transport exhaust total	11140	316	416
Road transport non exhaust total	0	0	0
Other mobile sources total	2882	165	112
Domestic total	14022	481	527
Civil aviation (International)	976	4	33
Navigation (International)	1621	42	41

Road transport

CO₂ emissions are directly fuel consumption dependent and, in this way, the development in the emission reflects the trend in fuel consumption. As shown in Figure 3.3.14, the most important emission source for road transport is passenger cars, followed by heavy-duty vehicles, light-duty vehicles and 2-wheelers in decreasing order. In 2020, the respective emission shares were 54, 32, 13 and 1 %, respectively (Figure 3.3.17).

The majority of CH₄ emissions from road transport come from gasoline passenger cars (Figure 3.3.15). The emission drop from 1992 onwards is explained by the penetration of catalyst cars into the Danish fleet. The 2020 emission shares for CH₄ were 62, 23, 13 and 2 % for passenger cars, 2-wheelers, heavy-duty vehicles and light-duty vehicles, respectively (Figure 3.3.17).

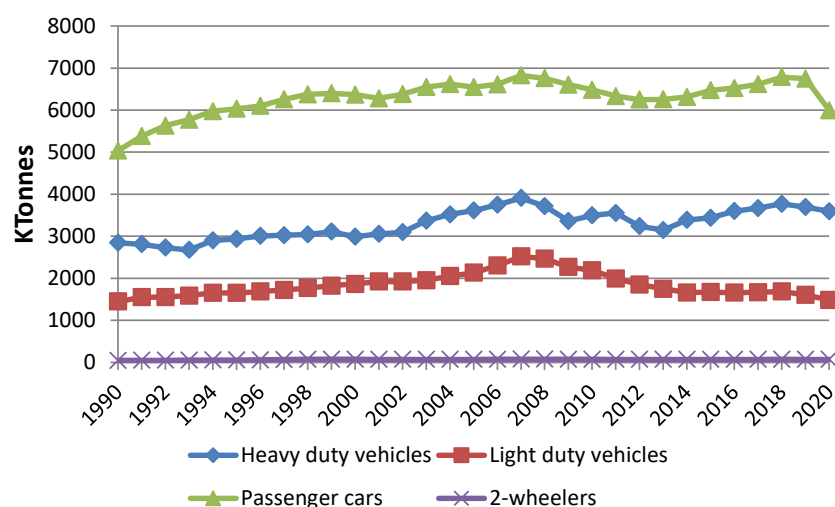

Figure 3.3.14 CO₂ emissions (k-tonnes) per vehicle type for road transport 1990-2020.

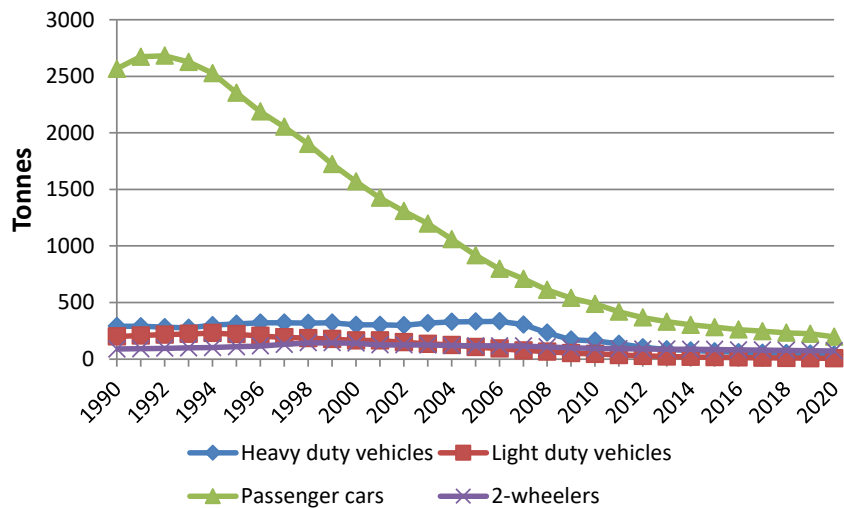

Figure 3.3.15 CH₄ emissions (tonnes) pr. vehicle type for road transport 1990-2020.

An undesirable environmental side effect of the introduction of catalyst cars is the increase in the emissions of N₂O from the first generation of catalyst cars (Euro 1) compared to conventional cars. The emission factors for later catalytic converter technologies are considerably lower than the ones for Euro 1, thus causing the emissions to decrease from 1998 onwards (Figure 3.3.16). In 2020, emission shares for passenger cars, heavy and light-duty vehicles were 57, 32 and 10 %, of the total road transport N₂O, respectively (Figure 3.3.17).

Referring to the fourth IPCC assessment report, 1 g CH₄ and 1 g N₂O has the greenhouse effect of 25 and 298 g CO₂, respectively. In spite of the relatively large CH₄ and N₂O global warming potentials, the largest contribution to the total CO₂ emission equivalents for road transport comes from CO₂, and the CO₂ emission equivalent shares per vehicle category are almost the same as the CO₂ shares.

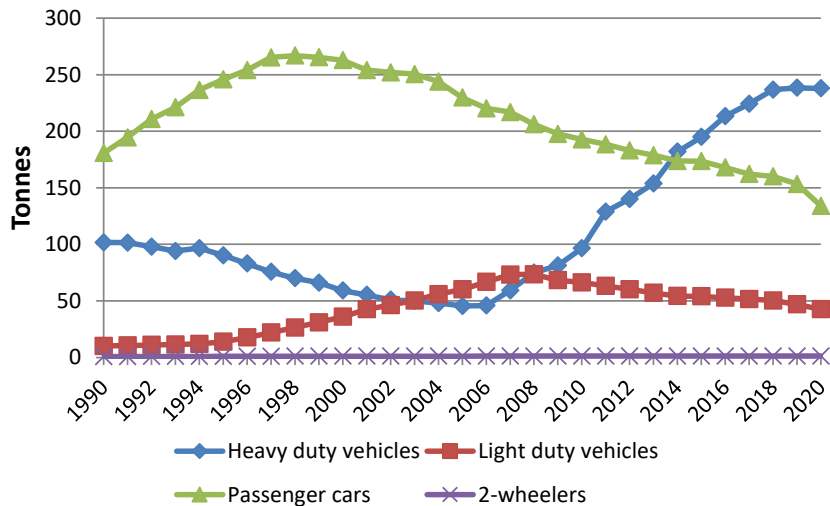

Figure 3.3.16 N₂O emissions (tonnes) per vehicle type for road transport 1990-2020.

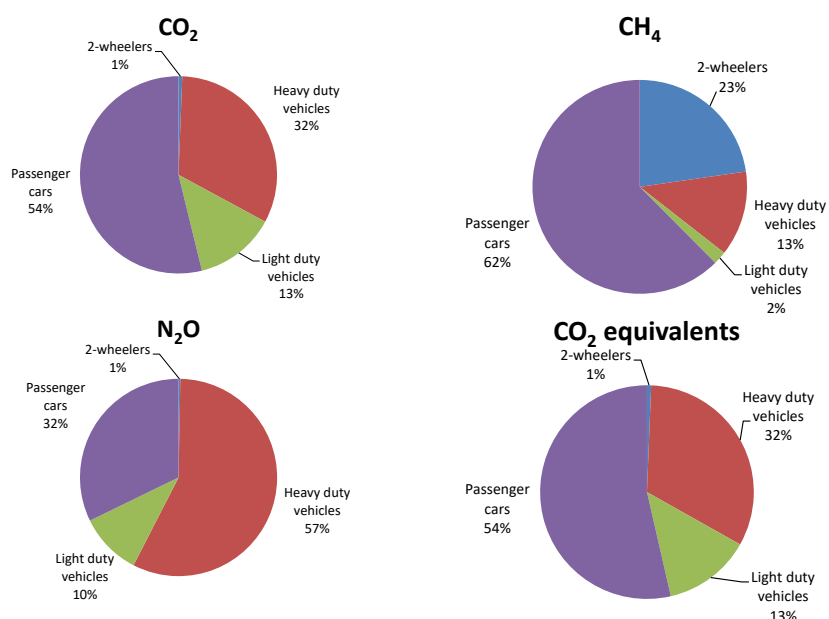

Figure 3.3.17 CO₂, CH₄ and N₂O emission shares and GHG equivalent emission distribution for road transport in 2020.

Other mobile sources

For other mobile sources, the highest CO₂ emissions in 2020 come from Agriculture/forestry/fisheries (1A4c), Industry-other (1A2g) and Navigation (1A3d), with shares of 39 %, 19 %, 16, respectively (Figure 3.3.21). The 1990-2020 emission trend is directly related to the fuel consumption development in the same time-period. Minor CO₂ emission contributors are sectors such as Commercial/Institutional (1A4a), Residential (1A4b), Railways (1A3c), Civil Aviation (1A3a) and Other (1A5).

For CH₄, the most important sources are Agriculture/forestry/fisheries (1A4c), Navigation (1A3d), Commercial/Institutional (1A4a), Industry-other (1A2g), and Residential (1A4b), see Figure 3.3.21. The emission shares are 36 %, 19 %, 18 %, 9 % and 9 %, respectively in 2020. For the remaining sectors the emission shares 6 % or less. The CH₄ emission contributions from Commercial/Institutional (1A4a) and Residential (1A4b) are quite high compared to their relative fuel consumption (and CO₂ emissions) contributions, due the high CH₄ emission factors for gasoline fuelled working machinery in general.

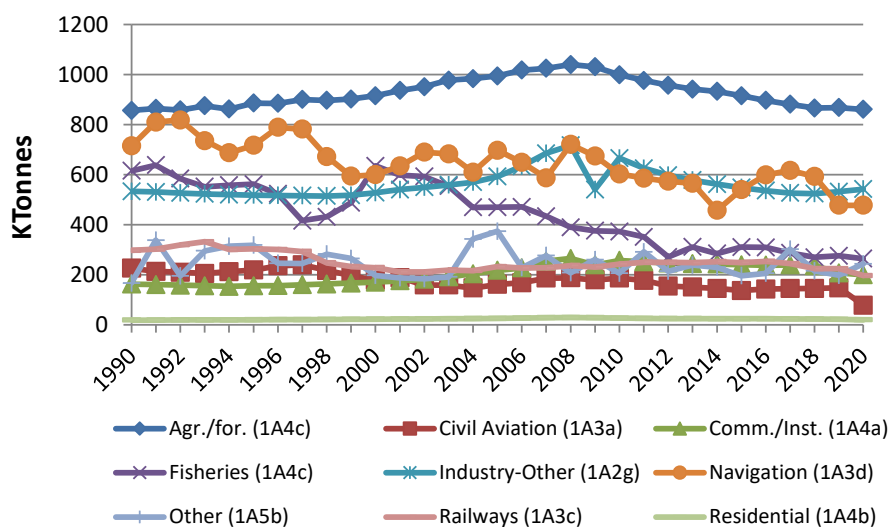

Figure 3.3.18 CO₂ emissions (ktonnes) in CRF sectors for other mobile sources 1990-2020.

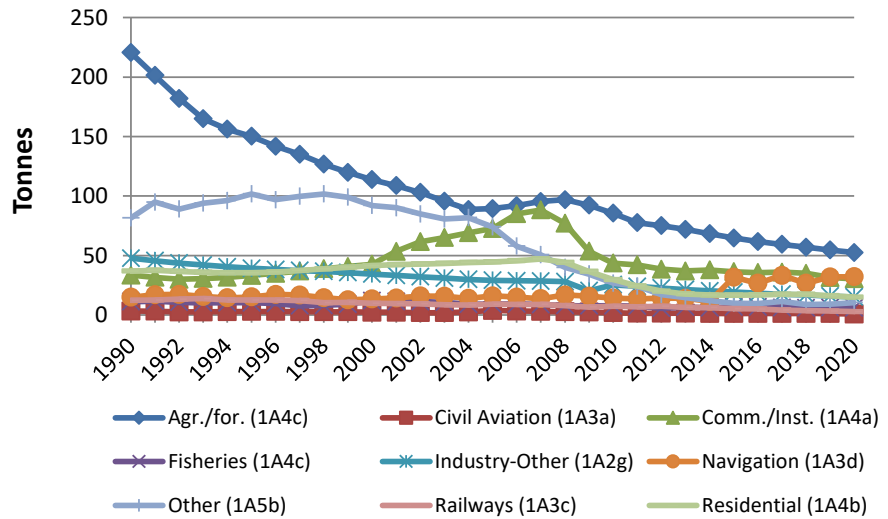

Figure 3.3.19 CH₄ emissions (tonnes) in CRF sectors for other mobile sources 1990-2020.

For N₂O, the emission trend in sub-sectors is the same as for fuel consumption and CO₂ emissions (Figure 3.3.20).

As for road transport, CO₂ alone contributes with by far the most CO₂ emission equivalents in the case of other mobile sources, and per sector the CO₂ emission equivalent shares are almost the same as those for CO₂, itself (Figure 3.3.21).

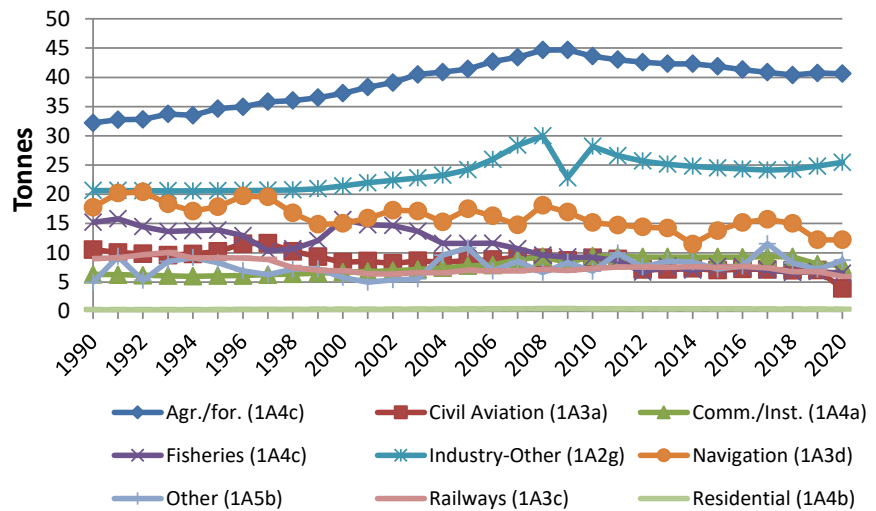

Figure 3.3.20 N₂O emissions (tonnes) in CRF sectors for other mobile sources 1990-2020.

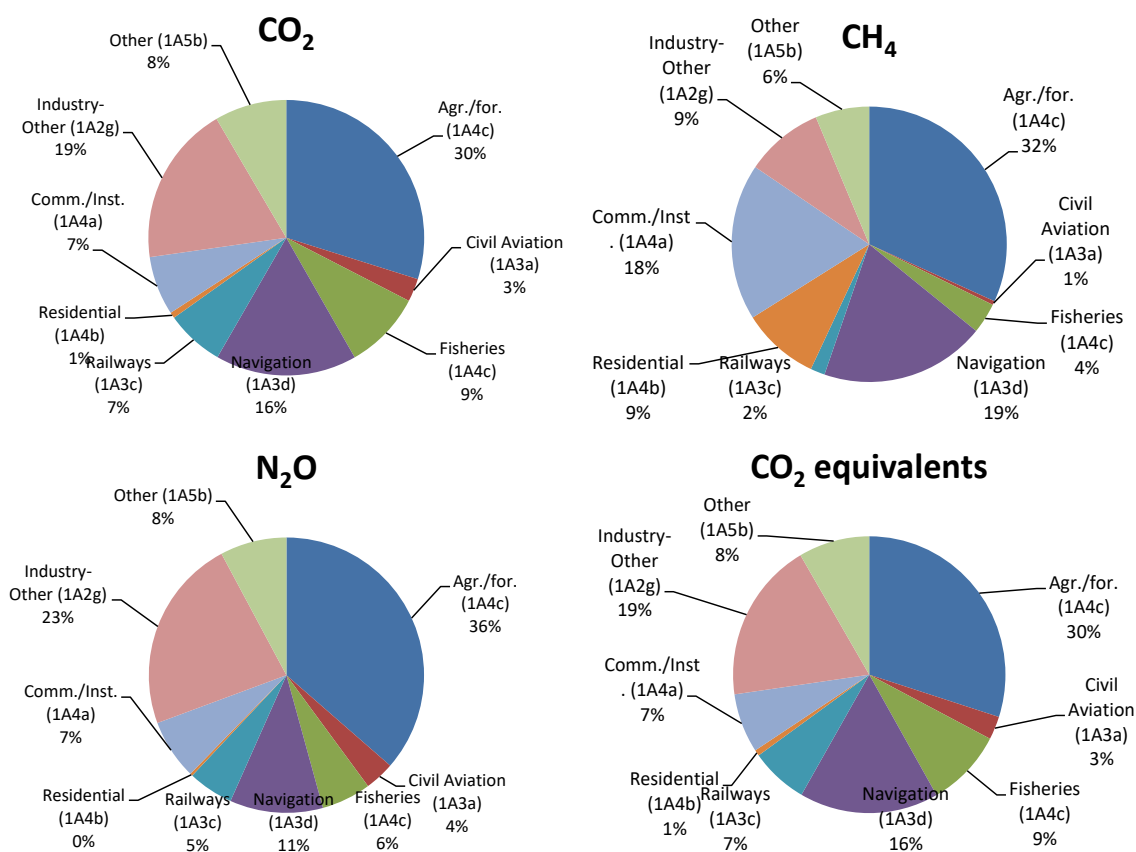

Figure 3.3.21 CO₂, CH₄ and N₂O emission shares and GHG equivalent emission distribution for other mobile sources in 2020.

Emissions of SO₂, NO_x, NMVOC and CO

For road transport and other mobile sources the emission figures of SO₂, NO_x, NMVOC and CO in the time series 1990-2020 are given in Annex 3.B.16 (CRF format) and are shown for 1990 and 2020 in Annex 3.B.15 (CollectER format). For further explanations regarding these emissions, please refer to the Danish IIR report (Nielsen et al. 2021).

International transport

The most important emissions from bunker fuel consumption (fuel consumption for international transport) are SO₂ and NO_x. In terms of greenhouse gas emissions, the level of emissions from Danish bunker fuel consumption are 19 %, 9 % and 14 %, respectively, for CO₂, CH₄ and N₂O, compared with the emission total for mobile sources in 2020.

The bunker emission totals of CO₂, CH₄ and N₂O are shown in Table 3.3.4 for 2020, split into sea transport and civil aviation. All emission figures in the 1990-2020 time series are given in Annex 3.B.16 (CRF format). In Annex 3.B.15, the emissions are also given in CollectER format for the years 1990 and 2020.

For further explanations of SO₂ and NO_x emissions from bunkers please refer to the Danish IIR report (Nielsen et al. 2021).

The differences in CH₄ emissions between navigation and civil aviation are much larger than the differences in fuel consumption (and derived CO₂ emissions), and display a poor emission performance for international sea transport. In broad terms, the emission trends shown in Figure 3.3.22 are similar to the fuel consumption development.

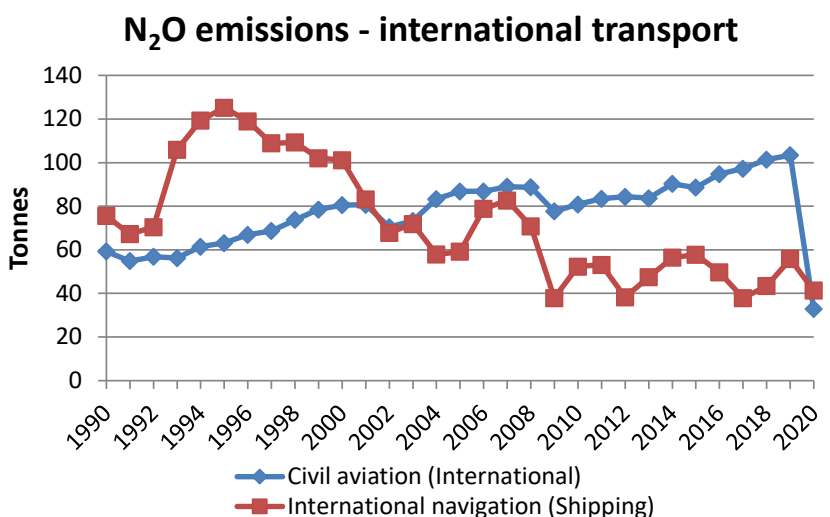
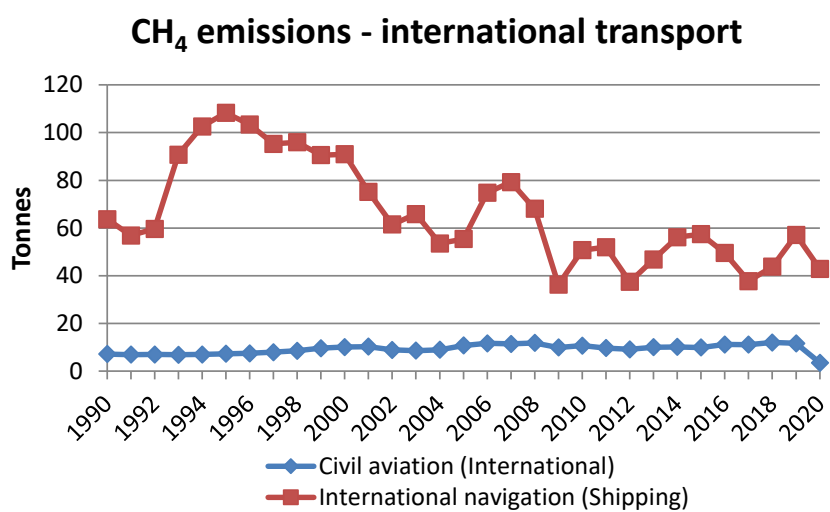
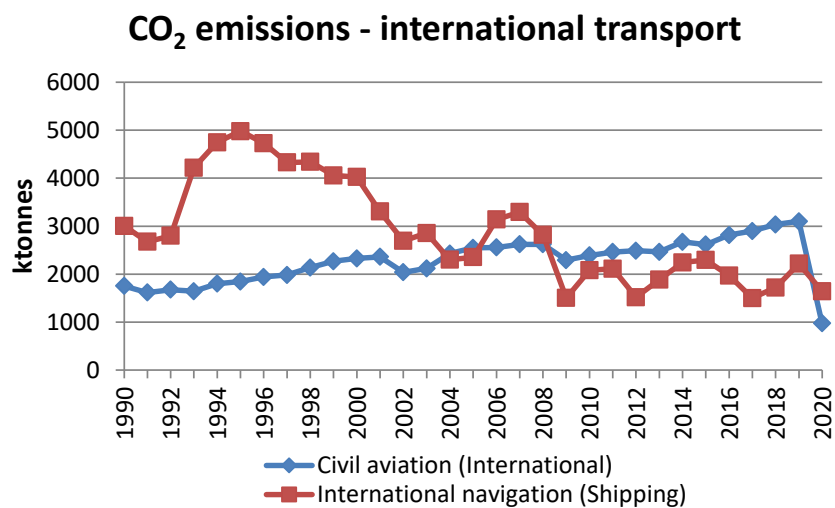

Figure 3.3.22 CO₂, CH₄ and N₂O emissions for international transport 1990-2020.

3.3.2 Methodological issues

The description of methodologies and references for the transport part of the Danish inventory is given in two sections: one for road transport and one for the other mobile sources.

Methodology and references for Road Transport

For road transport, the detailed methodology (Tier 3) is used to make annual estimates of the Danish emissions, as described in the EMEP/EEA Air Pollutant Emission Inventory Guidebook (EMEP/EEA, 2019). The actual calculations are made with a model developed by ENVS, using the European COPERT 5 model methodology (EMEP/EEA, 2019). In COPERT, fuel consumption and emission simulations can be made for operationally hot engines, taking into account gradually stricter emission standards and emission degradation due to catalyst wear. Furthermore, the emission effects of cold-start and evaporation are simulated.

Vehicle fleet and mileage data

Corresponding to the COPERT 5 fleet classification, all present and future vehicles in the Danish fleet are grouped into vehicle classes, sub-classes and layers. The layer classification is a further division of vehicle sub-classes into groups of vehicles with the same average fuel consumption and emission behaviour, according to EU emission legislation levels. Table 3.3.5 gives an overview of the different model classes and sub-classes, and all model layers the complete list of layer level with implementation years are shown in Annex 3.B.1.

Table 3.3.5 Model vehicle classes and sub-classes and trip speeds.

Vehicle classes	Fuel type	Engine size/weight	Trip speed [km pr h]		
			Urban	Rural	Highway
PC	Gasoline	< 0.8 l.	40	70	100
PC	Gasoline	0.8 - 1.4 l.	40	70	100
PC	Gasoline	1.4 – 2 l.	40	70	100
PC	Gasoline	> 2 l.	40	70	100
PC	Diesel	< 0.8 l.	40	70	100
PC	Diesel	0.8 - 1.4 l.	40	70	100
PC	Diesel	< 1.4 - 2 l.	40	70	100
PC	Diesel	> 2 l.	40	70	100
PC	2-stroke		40	70	100
PC	LPG		40	70	100
PC	CNG		40	70	100
PC	Plug-in hybrid		40	70	100
LCV	Gasoline	<1305 kg	40	65	80
LCV	Gasoline	1305-1760 kg	40	65	80
LCV	Gasoline	>1760 kg	40	65	80
LCV	Diesel	<1305 kg	40	65	80
LCV	Diesel	1305-1760 kg	40	65	80
LCV	Diesel	>1760 kg	40	65	80
LCV	LPG	<1305 kg	40	65	80
LCV	LPG	1305-1760 kg	40	65	80
LCV	LPG	>1760 kg	40	65	80
LCV	CNG	<1305 kg	40	65	80
LCV	CNG	1305-1760 kg	40	65	80
LCV	CNG	>1760 kg	40	65	80
LCV	Plug-in hybrid	<1305 kg	40	65	80
LCV	Plug-in hybrid	1305-1760 kg	40	65	80
LCV	Plug-in hybrid	>1760 kg	40	65	80
Trucks	Gasoline		35	60	80
Trucks	Diesel/CNG	Rigid 3,5 - 7,5t	35	60	80
Trucks	Diesel/CNG	Rigid 7,5 - 12t	35	60	80
Trucks	Diesel/CNG	Rigid 12 - 14 t	35	60	80
Trucks	Diesel/CNG	Rigid 14 - 20t	35	60	80
Trucks	Diesel/CNG	Rigid 20 - 26t	35	60	80
Trucks	Diesel/CNG	Rigid 26 - 28t	35	60	80
Trucks	Diesel/CNG	Rigid 28 - 32t	35	60	80
Trucks	Diesel/CNG	Rigid >32t	35	60	80
Trucks	Diesel/CNG	TT/AT 14 - 20t	35	60	80
Trucks	Diesel/CNG	TT/AT 20 - 28t	35	60	80
Trucks	Diesel/CNG	TT/AT 28 - 34t	35	60	80
Trucks	Diesel/CNG	TT/AT 34 - 40t	35	60	80
Trucks	Diesel/CNG	TT/AT 40 - 50t	35	60	80
Trucks	Diesel/CNG	TT/AT 50 - 60t	35	60	80
Trucks	Diesel/CNG	TT/AT >60t	35	60	80
Urban buses	Gasoline		30	50	70
Urban buses	Diesel/CNG	< 15 tonnes	30	50	70
Urban buses	Diesel/CNG	15-18 tonnes	30	50	70
Urban buses	Diesel/CNG	> 18 tonnes	30	50	70
Coaches	Gasoline		35	60	80
Coaches	Diesel/CNG	< 15 tonnes	35	60	80
Coaches	Diesel/CNG	15-18 tonnes	35	60	80
Coaches	Diesel/CNG	> 18 tonnes	35	60	80
Mopeds	Gasoline		30	30	-
Motorcycles	Gasoline	2 stroke	40	70	100
Motorcycles	Gasoline	< 250 cc.	40	70	100
Motorcycles	Gasoline	250 – 750 cc.	40	70	100
Motorcycles	Gasoline	> 750 cc.	40	70	100

Fleet and annual mileage data are provided by DTU Transport for the vehicle categories present in COPERT 5 (Jensen, 2021). DTU Transport use data from the Danish vehicle register kept by Statistics Denmark. The vehicle register

data consist of vehicle type (passenger cars, vans, trucks, buses, mopeds, motorcycles), fuel type, vehicle weight, gross vehicle weight, engine size (passenger cars registered from 2005+), Euro norm, NEDC type approval fuel efficiency value (passenger cars registered from 1997+) and vehicle first registration year. The Euro norm information is very complete in the Danish vehicle register for vehicle first registrations 2001 onwards for trucks and buses and 2011 onwards in the case of passenger cars and vans. For vehicles with no EU norm information, the EU norm is assigned, associated with the date for first registration (entry into service) listed in Table 3.3.6.

In order to establish engine size data for passenger cars registered before 2005, a weight class-engine size transformation key is used examined by Cowi (2008) for new Danish cars from 1998. For the years before 1998, data for 1998 is used, and for the years 1999-2004, a linear interpolation between 1998 and 2005 weight class-engine size relations is used. For trucks, truck driver registration notes gathered by Statistics Denmark are used to split the fleet figures of ordinary trucks into number of solo trucks and truck-trailer combinations. Further, the registration notes make it possible to assume the average total vehicle weight of the truck trailer combination. For articulated trucks also, the registration notes make it possible to assume the average total vehicle weight of the full articulated truck.

Danish mileage data comes from the Danish Road Directorate based on the Danish vehicle inspection program. Total mileage per year and vehicle category are derived for the years 1985-2020, together with a more detailed mileage matrix examined for the year 2008 (based on detailed vehicle inspection data analysis). The detailed mileage matrix contains annual mileage per vehicle subcategory for new vehicles and for every vintage back in time, which determines the yearly mileage reduction percentages as a function of vehicle age. In a first step, the detailed mileage matrix is combined with corresponding fleet numbers in order to estimate intermediate total mileages for each year on a detailed fleet level. Next, each year's detailed (intermediate) mileage figures are scaled according to the difference between true and intermediate total mileage per vehicle subcategory.

DTU Transport (Jensen, 2021) also provides information of the mileage split between urban, rural and highway driving based on traffic monitoring data. The respective average speeds come from The Danish Road Directorate (e.g. Winther & Ekman, 1998). Additional data for the moped fleet and motorcycle fleet disaggregation is given by The National Motorcycle Association (Markamp, 2013) and supplementary moped stock information is obtained from The Danish Bicycle Traders Association (Johnsen, 2018) and Prince (2021).

In addition, data from a survey made by the Danish Road Directorate (Hansen, 2010) has given information of the total mileage driven by foreign cars, vans, coaches and trucks on Danish roads in 2009 and a follow-up survey in 2014 has given additional information. For trucks, the mileage contribution from foreign vehicles has been added to the total mileage on Danish roads for Danish truck-trailers and articulated trucks in two gross vehicle weight categories, < 40 tonnes and > 40 tonnes. The data has been further processed by DTU Transport; by using appropriate assumptions, the mileage have been backcasted to 1985 and forecasted to 2020.

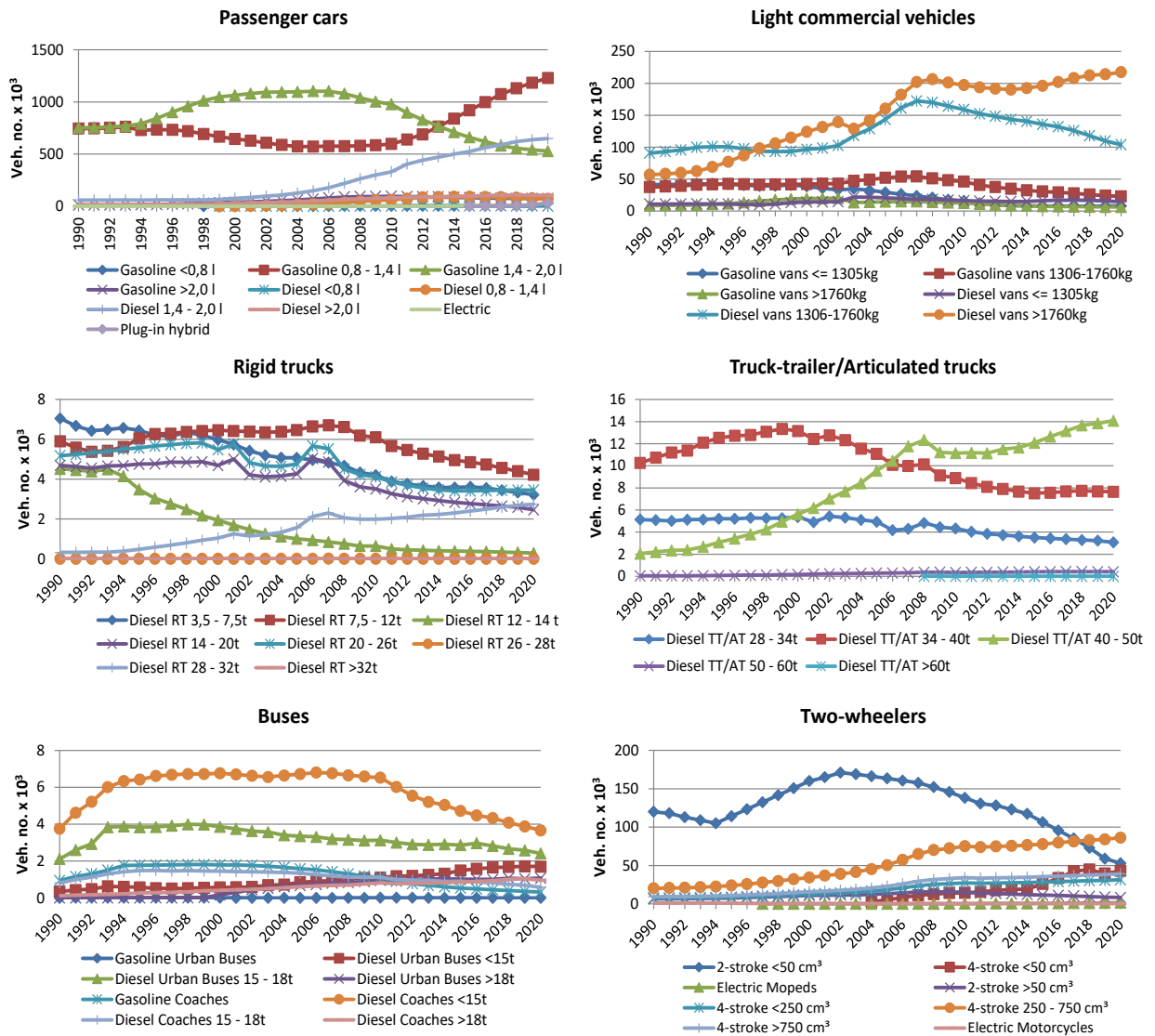

Figure 3.3.23 Number of vehicles in sub-classes in 1990-2020.

For passenger cars, the engine size differentiation is less certain for the years before 2005. The increase in the total number of passenger cars is mostly due to a growth in the number of diesel cars between 1.4 and 2 litres (from the 2000's up to now). Until 2005, there has been a decrease in the number of gasoline cars with an engine size between 0.8 and 1.4 litres. These cars, however, have also increased in numbers during the later years, while the number of 1.4-2 litres gasoline cars has decreased. Since the late 1990's small cars (< 0.8 l gasoline and <1.4 l. diesel) has slowly begun to penetrate the fleet.

There has been a considerable growth in the number of diesel light-duty vehicles from 1985 to 2006; the number of vehicles has however decreased somewhat after 2006 due to the restructuring of car taxes that made it less advantageous buying vans for private use.

For the truck-trailer and articulated truck combinations, there is a tendency towards the use of increasingly fewer but larger trucks throughout the time period. The decline in fleet numbers for many of the truck categories is due to the combined effects of the global financial crisis, the fleet shift towards fewer and larger trucks, international market competition (foreign transport companies are effectively gaining Danish market shares), and the reflagging of Danish commercial trucks to companies based in the neighbouring countries.

The sudden change in the level of urban bus and coach numbers from 1991 to 1995 is due to uncertain fleet data from Statistics Denmark.

The reason for the significant growth in the number of mopeds from 1994 to 2002 is the introduction of the so-called Moped 45 vehicle type. From 2004 onwards there is a gradual switch from 2-stroke to 4-stroke in new sales for this vehicle category. For motorcycles, the number of vehicles has grown throughout the 1990-2010 period, and from 2012-2020.

The vehicle numbers are summed up in EU emission layers for each year (Figure 3.3.24):

$$N_{j,y} = \sum_{i=FYear(j)}^{LYear(j)} N_{i,y} \quad (1)$$

Where N = number of vehicles, j = layer, y = year, i = first year of registration.

Weighted annual mileages per layer are calculated as the sum of all mileage driven per first registration year divided by the total number of vehicles in the specific layer.

$$M_{j,y} = \frac{\sum_{i=FYear(j)}^{LYear(j)} N_{i,y} \cdot M_{i,y}}{\sum_{i=FYear(j)}^{LYear(j)} N_{i,y}} \quad (2)$$

Since 2006, economical incitements have been given to private vehicle owners to buy Euro 5 diesel passenger cars and vans in order to bring down the particulate emissions from diesel vehicles. The estimated sales between 2006 and 2010 have been examined by the Danish EPA and are included in the fleet data behind the Danish inventory (Winther, 2011).

Vehicle numbers and weighted annual mileages per layer are shown in Annex 3.B.1 and 3.B.2 for 1990-2020. The trends in vehicle numbers per layer are also shown in Figure 3.3.24. The latter figure shows how vehicles complying with the gradually stricter EU emission levels (EURO 1-6, Euro I-VI etc.) have been introduced into the Danish motor fleet.

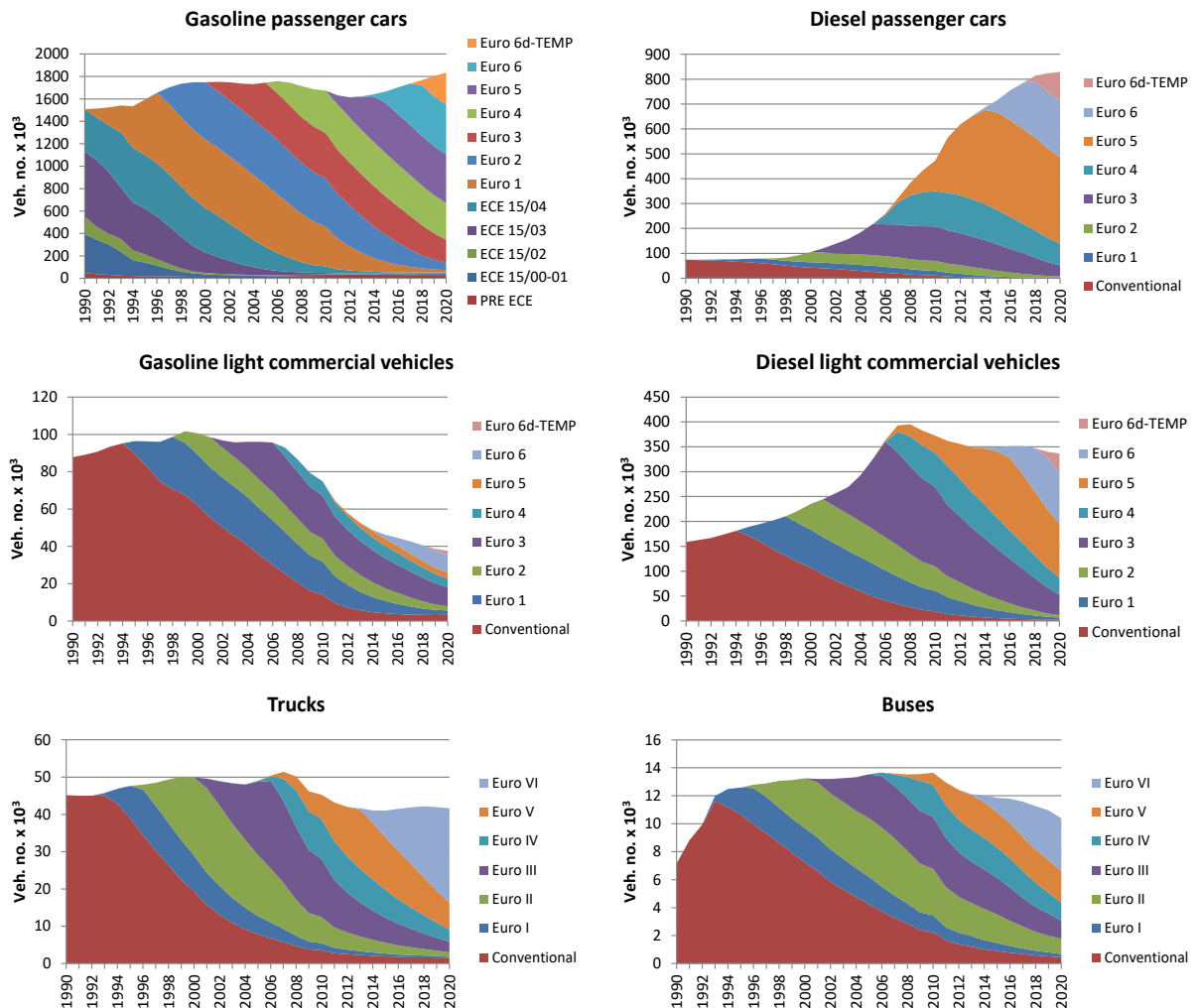

Figure 3.3.24 Layer distribution of vehicle numbers per vehicle type in 1990-2020.

Emission legislation

The EU 443/2009 regulation sets new emission performance standards for new passenger cars as part of the Community's integrated approach to reduce CO₂ emissions from light-duty vehicles. Some key elements of the adopted text are as follows:

- **Limit value curve:** the fleet average to be achieved by all cars registered in the EU is 130 gram CO₂ per kilometre (g per km). A so-called limit value curve implies that heavier cars are allowed higher emissions than lighter cars while preserving the overall fleet average.
- **Further reduction:** a further reduction of 10 g CO₂ per km, or equivalent if technically necessary, will be delivered by other technological improvements and by an increased use of sustainable biofuels.
- **Phasing-in of requirements:** in 2012, 65 % of each manufacturer's newly registered cars must comply on average with the limit value curve set by the legislation. This will rise to 75 % in 2013, 80 % in 2014, and 100 % from 2015 onwards.
- **Lower penalty payments for small excess emissions until 2018:** if the average CO₂ emissions of a manufacturer's fleet exceed its limit value in any year from 2012, the manufacturer has to pay an excess emissions premium for each car registered. This premium amounts to €5 for the first g per km of exceedance, €15 for the second g per km, €25 for the third g per km, and

€95 for each subsequent g per km. From 2019, already the first g per km of exceedance will cost €95.

- **Long-term target:** a target of 95g CO₂ per km is specified for the year 2021.
- **Eco-innovations:** Manufacturers can be granted a maximum of 7g per km of emission credits on average for their fleet if they equip vehicles with innovative technologies, based on independently verified data.

The EU 510/2011 regulation sets new emission performance standards for new light commercial vehicles (vans). Some key elements of the regulation are as follows:

- **Target dates:** the EU fleet average of 175 g CO₂ per km will be phased in between 2014 and 2017. In 2014, an average of 70 % of each manufacturer's newly registered vans must comply with the limit value curve set by the legislation. This proportion will rise to 75 % in 2015, 80 % in 2016, and 100 % from 2017 onwards.
- **Limit value curve:** emissions limits are set according to the mass of vehicle, using a limit value curve. The curve is set in such a way that a fleet average of 175 grams of CO₂ per kilometre is achieved. A so-called limit value curve of 100 % implies that heavier vans are allowed higher emissions than lighter vans while preserving the overall fleet average. Only the fleet average is regulated, so manufacturers will still be able to make vehicles with emissions above the limit value curve provided these are balanced by other vehicles, which are below the curve.
- **Vehicles affected:** the vehicles affected by the legislation are vans, which account for around 12 % of the market for light-duty vehicles. This includes vehicles used to carry goods weighing up to 3.5t (vans and car-derived vans, known as N1) and which weigh less than 2610 kg when empty.
- **Long-term target:** a target of 147g CO₂ per km is specified for the year 2020.
- **Excess emissions premium for small excess emissions until 2018:** if the average CO₂ emissions of a manufacturer's fleet exceed its limit value in any year from 2014, the manufacturer has to pay an excess emissions premium for each van registered. This premium amounts to €5 for the first g per km of exceedance, €15 for the second g per km, €25 for the third g per km, and €95 for each subsequent g per km. From 2019, the first g per km of exceedance will cost €95. This value is equivalent to the premium for passenger cars.
- **Super-credits:** vehicles with extremely low emissions (below 50g per km) will be given additional incentives whereby each low-emitting van will be counted as 3.5 vehicles in 2014 and 2015, 2.5 in 2016 and 1.5 vehicles in 2017.
- **Eco-innovations:** Manufacturers can be granted a maximum of 7g per km of emission credits on average for their fleet if they equip vehicles with innovative technologies, based on independently verified data.
- **Other flexibilities:** manufacturers may group together to form a pool and act jointly in meeting the specific emissions targets. Independent manufacturers who sell fewer than 22,000 vehicles per year can also apply to the Commission for an individual target instead.

On 17 April 2019, the European Parliament and the Council adopted Regulation (EU) 2019/631 setting CO₂ emission performance standards for new passenger cars and for new light commercial vehicles (vans) in the EU.

This Regulation started applying on 1 January 2020, replacing and repealing the former Regulations setting CO₂ emission standards for cars ((EC) 443/2009) and vans ((EU) 510/2011).

The following description of the regulation (EU) 2019/631 is given on the EU Commission Climate Action web page (https://ec.europa.eu/clima/policies/transport/vehicles/regulation_en). The main elements of the regulation are:

Target levels

New EU fleet-wide CO₂ emission targets are set for the years 2025 and 2030, both for newly registered passenger cars and newly registered vans.

These targets are defined as a percentage reduction from the 2021 starting points:

- Cars: 15% reduction from 2025 on and 37.5% reduction from 2030 on
- Vans: 15% reduction from 2025 on and 31% reduction from 2030 on

The specific emission targets for manufacturers to comply with, are based on the EU fleet-wide targets, taking into account the average test mass of a manufacturer's newly registered vehicles.

Incentive mechanism for zero- and low-emission vehicles (ZLEV)

A ZLEV is defined in the regulation as a passenger car or a van with CO₂ emissions between 0 and 50 g/km.

To incentivise the uptake of ZLEV, a crediting system is introduced from 2025 on.

The specific CO₂ emission target of a manufacturer will be relaxed if its share of ZLEV registered in a given year exceeds the following benchmarks:

- Cars: 15 % ZLEV from 2025 on and 35 % ZLEV from 2030 on
- Vans: 15 % ZLEV from 2025 on and 30 % ZLEV from 2030 on

A one percentage point exceedance of the ZLEV benchmark will increase the manufacturer's CO₂ target (in g CO₂ per km) by one percent. The target relaxation is capped at maximum 5 % to safeguard the environmental integrity of the regulation.

For calculating the ZLEV share in a manufacturer's fleet, an accounting rule applies. This gives a greater weight to ZLEV with lower CO₂ emissions.

In addition, for cars only, during the period 2025 to 2030, a greater weight is given to ZLEV registered in Member States with a low ZLEV uptake in 2017, and this as long as the ZLEV share in the Member State's fleet of newly registered cars does not exceed 5 %.

Pooling, exemptions and derogations

The provisions on pooling between manufacturers are the same as under the previous regulations. Pooling between car and van manufacturers is not possible.

The exemption of manufacturers registering less than 1,000 cars or vans per year, as well as the derogation possibility for “small volume” car and van manufacturers, have also been maintained.

The derogation possibility for “niche” car manufacturers, i.e. those registering between 10,000 and 300,000 cars per year, will end after the year 2028. In the years 2025 to 2028, the derogation target for those manufacturers will be 15 % below the 2021 derogation target.

Eco-innovations

The provisions regarding the “eco-innovation” credits for emission savings due to the application of innovative emission reduction technologies not covered by the standard test cycle CO₂ measurement are largely unchanged compared to the previous regulations.

New is that the efficiency improvements for air conditioning systems will become eligible as eco-innovation technologies as of 2025 and that the cap of 7 g per km may be adjusted by the Commission through a delegated act.

Governance

Two new elements have been introduced to reinforce the effectiveness of the regulation.

These concern

- the verification of CO₂ emissions of vehicles in-service and
- measures to ensure that the emission test procedure yields results which are representative of real-world emissions.

In-service verification

Manufacturers are required to ensure correspondence between the CO₂ emissions recorded in the certificates of conformity of their vehicles and the CO₂ emissions of vehicles in-service measured according to “World-Harmonized Light-Duty Vehicles Test Procedure” (WLTP).

This correspondence shall be verified by type-approval authorities in selected vehicles. The authorities shall also verify the presence of any strategies artificially improving the vehicle’s performance in the type-approval tests.

On the basis of their findings, type-approval authorities shall, where needed, ensure the correction of the certificates of conformity and may take other necessary measures set out in the Type Approval Framework Regulation.

Deviations found in the CO₂ emissions of vehicles in service shall be reported to the Commission, who shall take them into account for the purpose of calculating the average specific emissions of a manufacturer.

Real-world emissions

To prevent the gap between emissions tested in the laboratory and real-world emissions from increasing, the Commission shall, from 2021 on, regularly collect data on the real-world CO₂ emissions and energy consumption of cars and vans using the on-board fuel consumption monitoring devices (OBFDM).

The Commission shall monitor how that gap evolves between 2021 and 2026 and, on that basis, assess the feasibility of a mechanism to adjust the manufacturer's average specific CO₂ emissions as of 2030.

The detailed procedures for collecting and processing the data shall be adopted by means of implementing acts.

Life-cycle emissions

By 2023, the Commission shall evaluate the possibility of developing a common methodology for the assessment and reporting of the full life-cycle CO₂ emissions of cars and vans.

Review

The Commission shall review the effectiveness of the regulation and report on this to the European Parliament and the Council.

This review shall cover i.a. the following:

- real world representativeness of the CO₂ emission and energy consumption values,
- deployment of ZLEV,
- roll-out of recharging and refuelling infrastructure,
- role of synthetic and advanced alternative fuels produced with renewable energy,
- emission reductions observed for the existing fleet,
- ZLEV incentive mechanism,
- impacts for consumers,
- aspects related to the just transition,
- impacts for consumers, aspects related to the just transition,
- 2030 targets and identification of a pathway for emission reductions beyond 2030.

As part of the review, the Commission shall assess the feasibility of developing real-world emission test procedures, as well as the possibility to assign revenues from the fines to a specific fund or relevant programme with the objective to ensure a just transition towards a climate neutral economy.

Finally, the Commission shall review the Car Labelling Directive by end 2020, covering both CO₂ and air pollutant emissions of cars and evaluating the options for introducing a fuel economy and CO₂ emissions label for vans.

The Regulation (EU) 2019/1242 setting CO₂ emission standards for heavy-duty vehicles entered into force on 14 August 2019.

The following description of the EU regulation 2019/1242 is taken from the EU Commission Climate Action web page (https://ec.europa.eu/clima/policies/transport/vehicles/heavy_en). The main elements of the regulation are:

Target levels

From 2025 on, manufacturers will have to meet the targets set for the fleet-wide average CO₂ emissions of their new lorries registered in a given calendar year. Stricter targets will start applying from 2030 on.

The targets are expressed as a percentage reduction of emissions compared to EU average in the reference period (1 July 2019–30 June 2020):

- from 2025 onwards: 15% reduction
- from 2030 onwards: 30% reduction

The 2025 target can be achieved using technologies that are already available on the market. The 2030 target will be assessed in 2022 as part of the review of the regulation.

As a first step, the CO₂ emission standards will cover large lorries, which account for 65% to 70% of all CO₂ emissions from heavy-duty vehicles.

As part of the 2022 review, the Commission should assess the extension of the scope to other vehicle types such as smaller lorries, buses, coaches and trailers.

Incentive mechanism for zero- and low-emission vehicles (ZLEV)

The regulation includes an incentive mechanism for

- zero-emission vehicles (ZEV), lorries with no tailpipe CO₂ emissions
- low-emission vehicles (LEV), lorries with a technically permissible maximum laden mass of more than 16 t, with CO₂ emissions of less than half of the average CO₂ emissions of all vehicles in its group registered in the 2019 reporting period.

To incentivise the uptake of ZLEV and reward early action, a super-credits system applies from 2019 until 2024, and can be used to comply with the target in 2025. A multiplier of 2 applies for ZEV, and a multiplier between 1 and 2 applies for LEV, depending on their CO₂ emissions. An overall cap of 3 % is set to preserve the environmental integrity of the system.

From 2025 onwards, the super-credits system is replaced by a benchmark-based crediting system, with a benchmark set at 2 %. The 2030 benchmark level will have to be set in the context of the 2022 review.

As a result, the average specific CO₂ emissions of a manufacturer are adjusted downwards if the share of ZLEV in its entire new heavy-duty vehicles fleet exceeds the 2 % benchmark, out of which at least 0.75 percentage points have to be vehicles subject to the CO₂ targets, i.e. the largest vehicles. Each percentage point of exceedance of the benchmark will decrease the manufacturer's average specific CO₂ emissions by one percent.

In both systems, ZEV not subject to the CO₂ targets are accounted in the incentive mechanism. Buses and coaches are excluded from the scheme. The ZEV not subject to the CO₂ targets can contribute to a maximum of 1.5 % CO₂ emissions reduction.

Cost-effective achievement of targets

The regulation includes several elements to support cost-effective implementation:

- Banking and borrowing to take account of long production cycles, including a reward for early action, while maintaining the environmental integrity of the targets
- Full flexibility for manufacturers to balance emissions between the different groups of vehicles within their portfolio
- Vocational vehicles, such as garbage trucks and construction vehicles, are exempted due to their limited potential for cost-efficient CO₂ reduction.

Governance

The following measures will ensure the effectiveness and enforcement of the targets. They are based on the experience from cars and vans:

- Assess the robustness and representativeness of the reference CO₂ emissions as a basis for calculating the EU fleet-wide emissions targets
- Collect, publish and monitor real-world fuel consumption data reported by manufacturers, based on mandatory standardised fuel consumption meters
- Introduce in-service conformity tests and mandate the reporting of deviations and the introduction of a correction mechanism
Apply financial penalties in case of non-compliance with the CO₂ targets. The level of the penalties is set to 4,250 euro per gCO₂ per tkm in 2025 and 6,800 euro per gCO₂ per tkm in 2030.

Review

The Commission shall review the effectiveness of the regulation and report on this to the European Parliament and the Council by 2022.

This review shall cover i.a.

- 2030 target and possible targets for 2035 and 2040;
- inclusion of other types of heavy-duty vehicles, including buses, coaches, trailers, vocational vehicles and considerations of EMS (European modular system);
- ZLEV incentive mechanism;
- real world representativeness of the CO₂ emission and energy consumption values;
- role of synthetic and advanced alternative fuels produced with renewable energy;
- possible introduction of a form of pooling;
- level of the excess emission premium.

By 2023, the Commission shall evaluate the possibility of developing a common methodology for the assessment and reporting of the full life-cycle CO₂ emissions of heavy-duty vehicles.

Monitoring and reporting of CO₂ emissions from heavy-duty vehicles

The following measures enable the implementation of the emission standards:

- Certification Regulation on the determination of the CO₂ emissions and fuel consumption of new lorries
- Regulation (EU) 2018/956 on monitoring and reporting

The monitoring and reporting regulation requires that, as of 1 January 2019:

- Member States monitor and report to the Commission information on the heavy-duty vehicles registered for the first time in the Union; and lorry manufacturers monitor and report to the Commission CO₂ emission and fuel consumption data as determined pursuant to the certification Regulation for each new vehicle produced for the EU market. This information will be calculated using the Vehicle Energy Consumption Calculation Tool (VECTO).

- The collected data on CO₂ emissions and fuel consumption together with other relevant technical information on the vehicles, including the aerodynamic drag, will be made publicly available by the European Environment Agency on behalf of the Commission, starting in 2021 to cover data monitored between 1 January 2019 and 30 June 2020.

The new system will complement the existing EU reporting system for cars and vans.

Vehicle Energy Consumption Calculation Tool (VECTO)

VECTO is a simulation software that can be used cost-efficiently and reliably to measure the CO₂ emissions and fuel consumption of heavy-duty vehicles for specific loads, fuels and mission profiles (e.g. long haul, regional delivery, urban delivery, etc.), based on input data from relevant vehicle components.

The tool has been developed by the Commission in close cooperation with stakeholders.

Related policy measures

This legislation complements other policy measures such as the Certification Regulation, Monitoring and Reporting Regulation, EU type-approval system, Eurovignette Directive, Fuel Quality Directive, Clean Vehicles Directive, Directive on maximum authorised weights and dimensions and Directive on the deployment of alternative fuels infrastructure.

For Euro 1-6 passenger cars and vans, the chassis dynamometer test cycle used in the EU for emission approval is the NEDC (New European Driving Cycle), see e.g. www.dieselnet.com. The test cycle is also used for fuel consumption measurements. The NEDC cycle consists of two parts, the first part being a 4-time repetition (driving length: 4 km) of the ECE test cycle. The latter test cycle is the so-called urban driving cycle⁵ (average speed: 19 km per h). The second part of the test is the run-through of the EUDC (Extra Urban Driving Cycle) test driving segment, simulating the fuel consumption under rural and highway driving conditions. The driving length of EUDC is 7 km at an average speed of 63 km per h. More information regarding the fuel measurement procedure can be found in the EU-directive 80/1268/EØF.

The NEDC test cycle is not adequately describing real world driving behaviour, and consequently, for diesel cars and vans, there is an increasing mismatch between the step wise lowered EU emission limits the vehicles comply with during the NEDC test cycle, and the more or less constant emissions from the same vehicles experienced during real world driving. In order to bridge this emission inconsistency gap a new test procedure, the “World-Harmonized Light-Duty Vehicles Test Procedure” (WLTP), has been developed which simulates much more closely real world driving behaviour. The WLTP test procedure gradually take effect from 2017.

For the new Euro 6 vehicles it has been decided that emission measurements must also be made with portable emission measurement systems (PEMS) during real traffic driving conditions with random acceleration and deceleration patterns. During the new Real Driving Emission (RDE) test procedure in a temporary phase, the emissions of NO_x are not allowed to exceed the NEDC

⁵ For Euro 3 and on, the emission approval test procedure was slightly changed. The 40 s engine warm up phase before start of the urban driving cycle was removed.

based Euro 6 emission limits by more than 110 % by 1 September 2017 for all new car models and by 1 September 2019 for all new cars (Euro 6d-TEMP). From 1 January 2020 in the final phase, the NO_x emission not-to-exceed levels are adjusted downwards to 50 % for all new car models and by 1/1 2021 for all new cars (Euro 6d). Implementation dates for vans are one year later.

In the road transport emission model, compromise dates for enter into service of the Euro 6d-TEMP technology are set to 1 September 2018 and 1 September 2019, for diesel cars and vans, respectively. For Euro 6d, the enter into service dates are set to 1 January 2021 and 1 January 2022 for cars and vans, respectively. (pers. comm. Katja Asmussen, Danish EPA, 2018).

For NO_x, VOC (NMVOC + CH₄), CO and PM, the emissions from road transport vehicles have to comply with the emission limit values agreed by the EU. An overview of the different emission layers in the road transport emission model and the corresponding EU emission directive numbers are given in Table 3.3.6. The specific emission limits are shown in Annex 2.B.3.

Table 3.3.6 shows the EU directive dates for new type approvals and the date for first registration (entry into service) of existing, previously type approved vehicle models. The latter date is used in the model for vehicles with no EU norm information given in the car register. In most cases the entry into service date used in the model is the same as the entry into service date specified by the EU directive.

For passenger cars and light commercial vehicles, the emission directives distinguish between three vehicle classes according to vehicle reference mass⁶: Passenger cars and light duty trucks (<1305 kg) have the same emission limits but different legislation dates. Light duty trucks (1305-1760 kg) and light duty trucks (>1760 kg) have the same legislation dates but different emission limits.

For heavy-duty vehicles (trucks and buses), the emission limits are given in g pr kWh and the measurements are carried out for engines in a test bench, using the ECE R-49, EU ESC (European Stationary Cycle) and ETC (European Transient Cycle) test cycles, depending on the Euro norm and exhaust gas after-treatment system installed. For Euro VI engines the WHSC (World Harmonized Stationary Cycle) and WHTC (World Harmonized Transient Cycle) test cycles are used. For a description of the test cycles, see e.g. www.dieselnet.com.

In terms of the sulphur content in the fuels used by road transportation vehicles, the EU directive 2003/17/EF describes the fuel quality standards agreed by the EU. In Denmark, the sulphur content in gasoline and diesel was reduced to 10 ppm in 2005, by means of a fuel tax reduction for fuels with 10 ppm sulphur contents.

⁶ Reference mass: net vehicle weight + mass of fuel and other liquids + 100 kg.

Table 3.3.6 Overview of emission layers in the road transport emission model and the related EU emission directives.

Vehicle category	Emission layer	EU directive	Type approval	First registration date
Passenger cars (gasoline)	PRE ECE	-	-	<1970-
	ECE 15/00-01	70/220 - 74/290	1972 ^a	1970 ^a
	ECE 15/02	77/102	1981 ^b	1979 ^b
	ECE 15/03	78/665	1982 ^c	1981 ^c
	ECE 15/04	83/351	1987 ^d	1986 ^d
Passenger cars (diesel)	Conventional	-	-	<1991-
Passenger cars	Euro 1	91/441	1.7.1992 ^e	1.1.1991 ^e
	Euro 2	94/12	1.1.1996	1.1.1997
	Euro 3	98/69	1.1.2000	1.1.2001
	Euro 4	98/69	1.1.2005	1.1.2006
	Euro 5	715/2007(692/2008)	1.9.2009	1.1.2011
	Euro 6	715/2007(692/2008)	1.9.2014	1.9.2015
	Euro 6d-TEMP	2016/646	1.9.2017	1.9.2018
	Euro 6d	2016/646	1.1.2020	1.1.2021
LCV < 1305 kg	Conventional	-	-	<1995
	Euro 1	91/441	1.10.1994	1.1.1995
	Euro 2	94/12	1.1.1998	1.1.1999
	Euro 3	98/69	1.1.2001	1.1.2002
	Euro 4	98/69	1.1.2006	1.1.2007
	Euro 5	715/2007(692/2008)	1.9.2010	1.1.2012
	Euro 6	715/2007(692/2008)	1.9.2015	1.9.2016
	Euro 6d-TEMP	2016/646	1.9.2018	1.9.2019
LCV 1305-1760 kg & > 1760 kg	Conventional	-	-	<1995
	Euro 1	93/59	1.10.1994	1.1.1995
	Euro 2	96/69	1.1.1998	1.1.1999
	Euro 3	98/69	1.1.2001	1.1.2002
	Euro 4	98/69	1.1.2006	1.1.2007
	Euro 5	715/2007	1.9.2010	1.1.2012
	Euro 6	715/2007	1.9.2015	1.9.2016
	Euro 6d-TEMP	2016/646	1.9.2018	1.9.2019
Heavy duty vehicles	Euro 0	88/77	1.10.1990	1.10.1990
	Euro I	91/542	1.10.1993	1.10.1993
	Euro II	91/542	1.10.1996	1.10.1996
	Euro III	1999/96	1.10.2000	1.10.2001
	Euro IV	1999/96	1.10.2005	1.10.2006
	Euro V	1999/96	1.10.2008	1.10.2009
	Euro VI	595/2009	1.1.2013	1.1.2014
Mopeds	Conventional	-	-	-
	Euro I	97/24	2000	2000
	Euro II	2002/51	2004	2004
	Euro III	2002/51	2014 ^f	2014 ^f
	Euro IV	168/2013	2017	2017
	Euro V	168/2013	2021	2021
Motor cycles	Conventional	-	0	0
	Euro I	97/24	2000	2000
	Euro II	2002/51	2004	2004
	Euro III	2002/51	2007	2007
	Euro IV	168/2013	2017	2017
	Euro V	168/2013	2021	2021

a,b,c,d: Expert judgement suggests that Danish vehicles enter into the traffic before EU directive first registration dates. The effective inventory starting years are a: 1970; b: 1979; c: 1981; d: 1986; e: The directive came into force in Denmark 1.10.1990.

Fuel consumption and emission factors

In practice, the emissions from vehicles in traffic are different from the legislation limit values and, therefore, the latter figures are not suited for total emission calculations. Besides difference in test versus real world driving behaviour, as discussed in the previous section, the emission limit values do not reflect the emission impact of cumulated mileage driven, and engine and exhaust after treatment maintenance levels for the vehicle fleet as a whole.

Therefore, in order to represent the Danish fleet and to support average national emission estimates, the selected emission factors must be derived from numerous emission measurements, using a broad range of real world driving patterns and a sufficient number of test vehicles. It is similarly important to have separate fuel consumption and emission data for cold-start emission calculations and gasoline evaporation (hydrocarbons).

The fuel consumption and emission factors used in the Danish inventory come from the COPERT 5 model⁷. The source for these data is various European measurement programmes. In general, the COPERT data are transformed into trip-speed dependent fuel consumption and emission factors for all vehicle categories and layers by using trip speeds as shown in Table 3.3.5. The factors are listed in Annex 2.B.4.

It should be noted that for PHEV (plug-in hybrid electric vehicles) cars and vans, the utility factor is set to 0.5, i.e. 50 % of total mileage is assumed to be battery driven, according to assumptions made by DEA (2021)⁸. The fuel consumption and emission factors for plug-in vehicles used in the Danish national emission inventories for road transport, and shown in the present NIR, only contain the part of fuel consumption and emissions related to the combustion of fossil fuel (gasoline) in the vehicles. The emissions related to the generation of the electricity used by battery electric vehicles and plug-in vehicles are included under stationary sources in the Danish emission inventories as prescribed by the UNFCCC reporting guidelines.

Adjustment for fuel efficient vehicles

For passenger cars, COPERT 5 include measurement based fuel consumption factors until Euro 4. A calculation function is provided for newer cars that one hand compensate for the trend towards more fuel efficient vehicles being sold during the later years and on the other hand compensate for the increasing fuel gap between fuel consumption measured during vehicle type approval and real world fuel consumption.

The COPERT calculation function and supporting data material basis is, however, not able to account for the fuel gaps between fuel consumption measured during vehicle type approval and real world fuel consumption for vehicles after 2014, as monitored by e.g. the International Council on Clean Transportation (ICCT), Tietge et al. (2019).

⁷ For vans, fuel consumption factors are not stratified according to vehicle weight classes in the COPERT model. For this vehicle category fuel consumption factor data are obtained from the HBEFA (Handbook of Emission Factors) model version 4.1 (e.g. Matzer et al., 2019).

⁸ The electric driven mileage shares for Danish urban, rural and highway driving conditions are derived by weighing in electric driven mileage shares for urban, rural and highway driving conditions obtained from HBEFA.

The baseline COPERT 5 fuel consumption factors for Euro 4, Euro 5 and Euro 6 passenger cars are adjusted in the following way.

In the Danish fleet and mileage database kept by DTU Transport, the type approval fuel efficiency value based on the NEDC driving cycle (TA_{NEDC}) is registered for each single car. Further, DTU Transport calculates a modified fuel efficiency value (FC_{inuse}) with the calculation function provided by COPERT 5 that better reflects the fuel consumption in real (“inuse”) traffic conditions.

The latter function uses TA_{NEDC} , vehicle weight, engine size and regression coefficients by first registration year, as input parameters (EMEP/EEA, 2019). For each new registration year, i , fuel type, f , and engine size, k , number based average values of TA_{NEDC} and FC_{inuse} are summed up and referred to as $TA_{NEDC}(i, f, k)$ and $TA_{inuse}(i, f, k)$. For vehicle new registrations after 2014, regression coefficients are used for 2014.

The FC_{inuse} function has been developed from a vehicle database consisting of new registered cars from 2006-2014 (Tietge et al. 2017). Hence, as previously mentioned, The FC_{inuse} function is not able to account for the fuel gaps after 2014, between type approval and real world fuel consumption as monitored by ICCT (Tietge et al., 2019).

To obtain $\overline{FC_{inuse}(i, f, k)}$ values for vehicle new registrations 2015-2020, the $FC_{inuse}(i, f, k)$ values for 2014 are adjusted for the years 2015-2020⁹ with an index function (indexed from 2014), $C_{ICCT}(i, f)$, based on the reported ICCT fuel gap figures by fuel type for the new registration years 2014-2020.

The most recent emission projections use the assumption from The Danish Energy Agency that Danish vehicle sales meet a slightly softer national target of 101.0 g CO₂/km in 2021, instead of the EU 95 g CO₂/km, due to increases in new sales of electric cars and plug-in hybrids.

In order to meet the 101.0 g CO₂/km target, the following approach is used to forecast the average TA_{NEDC} values ($TA_{NEDC}(i)$) until 2021. As a starting point, the average CO₂ emission factor (average from all new registrations) is calculated for the last historical year (2020) based on the registered average TA_{NEDC} values from DTU Transport. Next, the average CO₂ emission factor (and $TA_{NEDC}(i)$) for each future year’s new sold cars is reduced with a linear function, $C_{2021}(i)$, until the emission factor reaches 101.0 g CO₂/km in 2021. For years beyond 2021 annual fuel efficiency, improvement rates are used for new cars depending on fuel type as suggested by DEA (2021b).

The reduction function $C_{2021}(i)$ is then used to reduce the in use type approval fuel efficiency values, $FC_{inuse}(i, f, k)$, for the years between last historical year and 2021, for each of the fuel type/engine size fleet segments.

Subsequently these $\overline{FC_{inuse}(i, f, k)}$ values are aggregated by mileage into layer specific values for each inventory year ($FC_{inuse}(layer)$).

⁹ The ICCT monitoring report include new cars up to 2017. For new cars from 2018-2020, fuel gap figures are used for cars from 2017.

At the same time, COPERT provides fuel consumption factors for Euro 4 vehicles for a specific driving pattern composition¹⁰ that better describes real world driving for these specific vehicles. The factors build on the actual fuel measurements for the Euro 4 sample of COPERT vehicles ($FC_{\text{COPERT, sample}}$), used in the development of the Euro 4 emission factors in the COPERT model.

In a final step the ratio between the layer specific fuel factors for the Danish fleet ($FC_{\text{inuse}}(\text{layer})$) and the COPERT Euro 4 vehicles ($FC_{\text{COPERT, sample}}$) are used to scale the trip speed dependent COPERT 5 fuel consumption factors for Euro 4 layers onwards.

For vans, trucks, urban buses and coaches, annual fuel efficiency improvement rates are used for future new vehicles depending on fuel type as suggested by DEA (2021b).

Adjustment for EGR, SCR and filter retrofits

In COPERT 5, emission factors are available for Euro V heavy duty vehicles using exhaust gas recirculation (EGR) and selective catalyst reduction (SCR) exhaust emission aftertreatment systems, respectively. The estimated new sales of Euro V diesel trucks equipped with EGR and SCR during the 2006-2010 time periods has been examined by Hjelgaard and Winther (2011). These inventory fleet data are used in the Danish inventory to calculate weighted emission factors for Euro V trucks in different size categories.

During the 2000's urban environmental zones have been established in Danish cities in order to bring down the particulate emissions from diesel fuelled heavy duty vehicles. Driving in these environmental zones prescribe the use of diesel particulate filters. The Danish EPA has provided the estimated number of Euro I-III urban buses and Euro II-III trucks and tourist buses, which have been retrofitted with filters during the 2000's. These retrofit data are included in the Danish inventory by assuming that particulate emissions are lowered by 80 % compared with the emissions from the same Euro technology with no filter installed (Winther, 2011).

For all vehicle categories/technology levels not represented by measurements, the emission factors are produced by using reduction factors. The latter factors are determined by assessing the EU emission limits and the relevant emission approval test conditions, for each vehicle type and Euro class.

Adjustment of emission factors for Euro 5 diesel passenger cars influenced by the diesel scandal

In COPERT 5 new emission factors are available for those Euro 5 diesel passenger cars for which engine control software has been installed in order to reduce the emissions, as a result of the diesel scandal.

The Euro 5 vehicles in question were brought to vehicle workshops during the vehicle recall program from 2016-2018. A short description of the recall program and the cars included is given below:

- Engine software was updated in 70,946 cars, evenly shared by 1/3 in each of the years 2016-2018

¹⁰ The factors are derived from the Common Artemis Driving Cycle (CADC), with a 1/3 weight for each of the urban, rural and highway parts of CADC.

- Vehicle first registration years of the updated cars were between 2009-2016
- Engine sizes of the updated cars were < 1.4 l (9 %) and 1.4-2 l (91 %)

In the emission model, each year's updates were distributed into first registration year-engine size categories, according to their fleet shares in the respective first registration year-engine size categories.

The number of included cars in the software update program was provided by the Danish Safety Technology Authority (Bonde, 2021) and engine size and model year information was provided by Volkswagen (Hjortshøj, 2021).

Deterioration factors

For three-way catalyst cars, the emissions of NO_x, NMVOC and CO gradually increase due to catalyst wear and are, therefore, modified as a function of total mileage by the so-called deterioration factors. Even though the emission curves may be serrated for the individual vehicles, on average, the emissions from catalyst cars stabilize after a given cut-off mileage is reached due to OBD (On Board Diagnostics) and the Danish inspection and maintenance programme.

For each year, the deterioration factors are calculated per first registration year by using deterioration coefficients and cut-off mileages, as given in EMEP/EEA (2019), for the corresponding layer. The deterioration coefficients are given for the two driving cycles "Urban Driving Cycle" (UDF) and "Extra Urban Driving Cycle" (EUDF: urban and rural), with trip speeds of 19 and 63 km per hour, respectively.

Firstly, the deterioration factors are calculated for the corresponding trip speeds of 19 and 63 km per h in each case determined by the total cumulated mileage less than or exceeding the cut-off mileage. The Formulas 3 and 4 show the calculations for the "Urban Driving Cycle":

$$UDF = U_A \cdot MTC + U_B, MTC < U_{MAX} \quad (3)$$

$$UDF = U_A \cdot U_{MAX} + U_B, MTC \geq U_{MAX} \quad (4)$$

where UDF is the urban deterioration factor, U_A and U_B the urban deterioration coefficients, MTC = total cumulated mileage and U_{MAX} urban cut-off mileage.

In the case of trip speeds below 19 km per hour the deterioration factor, DF, equals UDF, whereas for trip speeds exceeding 63 km per hour, DF=EUDF (Danish rural and highway trip speed; c.f. Table 3.3.5). For trip speeds between 19 and 63 km per hour (Danish urban trip speed; c.f. Table 3.3.5) the deterioration factor, DF, is found as an interpolation between UDF and EUDF. Secondly, the deterioration factors, one for each of the three road types, are aggregated into layers by taking into account vehicle numbers and annual mileage levels per first registration year:

$$DF_{j,y} = \frac{\sum_{i=FYear(j)}^{LYear(j)} DF_{i,y} \cdot N_{i,y} \cdot M_{i,y}}{\sum_{i=FYear(j)}^{LYear(j)} DF_{i,y} \cdot N_{i,y}} \quad (5)$$

where DF is the deterioration factor.

For N₂O and NH₃, COPERT 5 takes into account deterioration as a linear function of mileage for gasoline fuelled EURO 1-6 passenger cars and light duty vehicles. The level of emission deterioration also relies on the content of sulphur in the fuel. The deterioration coefficients are given in EMEP/EEA (2019), for the corresponding layer. A cut-off mileage of 250 000 km is behind the calculation of the modified emission factors, and for the Danish situation the low sulphur level interval is assumed to be most representative. The deterioration factors are shown in Annex 3.B.6 for 2020.

Emissions and fuel consumption for hot engines

Emissions and fuel consumption results for operationally hot engines are calculated for each year and for layer and road type. The procedure is to combine fuel consumption and emission factors (and deterioration factors for catalyst vehicles), number of vehicles, annual mileage levels and the relevant road-type shares given in Table 3.3.5. For non-catalyst vehicles, this yields:

$$E_{j,k,y} = EF_{j,k,y} \cdot S_k \cdot N_{j,y} \cdot M_{j,y} \quad (6)$$

Here E = fuel consumption/emission, EF = fuel consumption/emission factor, S = road type share and k = road type.

For catalyst vehicles the calculation becomes:

$$E_{j,k,y} = DF_{j,k,y} \cdot EF_{j,k,y} \cdot S_k \cdot N_{j,y} \cdot M_{j,y} \quad (7)$$

Extra emissions and fuel consumption for cold engines

Extra emissions of NO_x, VOC, CH₄, CO, PM, N₂O, NH₃ and fuel consumption from cold start are simulated separately. For SO₂ and CO₂, the extra emissions are derived from the cold start fuel consumption results.

Each trip is associated with a certain cold-start emission level and is assumed to take place under urban driving conditions. The number of trips is distributed evenly across the months. First, cold emission factors are calculated as the hot emission factor times the cold:hot emission ratio. Secondly, the extra emission factor during cold start is found by subtracting the hot emission factor from the cold emission factor. Finally, this extra factor is applied on the fraction of the total mileage driven with a cold engine (the β-factor) for all vehicles in the specific layer.

The cold:hot ratios depend on the average trip length and the monthly ambient temperature distribution. The Danish temperatures for 2020 are given in Rubek et al. (2021). For previous years, temperature data are taken from similar reports available from The Danish Meteorological Institute (www.dmi.dk). The cold:hot ratios are equivalent for gasoline fuelled conventional passenger cars and vans, and for diesel passenger cars and vans, respectively, see EMEP/EEA (2019). For conventional gasoline and all diesel vehicles the extra emissions become:

$$CE_{j,y} = \beta \cdot N_{j,y} \cdot M_{j,y} \cdot EF_{U,j,y} \cdot (CEr - 1) \quad (8)$$

Where CE is the cold extra emissions, β = cold driven fraction, CE_r = Cold:Hot ratio.

For catalyst cars, the cold:hot ratio is also trip speed dependent. The ratio is, however, unaffected by catalyst wear. The Euro I cold:hot ratio is used for all later catalyst technologies. However, in order to comply with gradually stricter emission standards, the catalyst light-off temperature must be reached in even shorter periods of time for later EURO standards. Correspondingly, the β -factor for gasoline vehicles is reduced step-wise for Euro II vehicles and their successors.

For catalyst vehicles, the cold extra emissions are found from:

$$CE_{j,y} = \beta_{red} \cdot \beta_{EUROI} \cdot N_{j,y} \cdot M_{j,y} \cdot EF_{U,j,y} \cdot (CE_{rEUROI} - 1) \quad (9)$$

where β_{red} = the β reduction factor.

For CH₄, specific emission factors for cold driven vehicles are included in COPERT 5. The β and β_{red} factors for VOC are used to calculate the cold driven fraction for each relevant vehicle layer. The NMVOC emissions during cold start are found as the difference between the calculated results for VOC and CH₄.

For N₂O and NH₃, specific cold start emission factors are also proposed by COPERT 5. For catalyst vehicles, however, just like in the case of hot emission factors, the emission factors for cold start are functions of cumulated mileage (emission deterioration). The level of emission deterioration also relies on the content of sulphur in the fuel. The deterioration coefficients are given in EMEP/EEA (2019), for the corresponding layer. For cold start, the cut-off mileage and sulphur level interval for hot engines are used, as described in the deterioration factors paragraph.

Evaporative emissions from gasoline vehicles

For each year, evaporative emissions of hydrocarbons are simulated in the forecast model as hot and warm running losses, hot and warm soak loss and diurnal emissions. The calculations follow the Tier 2 approach in COPERT 5. The basic emission factors are season related (predefined by four ambient temperature intervals), for Danish climate conditions the temperature intervals [-5, 10], [0, 15] and [10, 25] °C are used. The emission factors are shown in more details in EMEP/EEA (2019).

Running loss emissions originate from vapour generated in the fuel tank while the vehicle is running. The distinction between hot and warm running loss emissions depends on engine temperature, i.e. the engine being either hot or cold. The emissions are calculated as annual mileage (broken down into cold and hot mileage totals using the β -factor) times the respective emission factors. For vehicles equipped with evaporation control (catalyst cars) only hot running loss emissions occur.

$$E_{j,y}^R = N_{j,y} \cdot \frac{M_{j,y}}{l_{trip}} \cdot ((1 - \beta) \cdot HR + \beta \cdot WR) \quad (10)$$

Where E^R is running loss emissions, l_{trip} = the average trip length, and HR and WR are the hot and warm running loss emission factors, respectively.

Hot and warm soak emissions also occur for carburettor vehicles (no evaporation control), whereas for catalyst cars (evaporation control) only hot soak emissions occur. The soak emissions are calculated as number of trips (broken down into cold and hot trip numbers using the β -factor) times respective emission factors:

$$E_{j,y}^S = N_{j,y} \cdot \frac{M_{j,y}}{l_{trip}} \cdot ((1-\beta) \cdot HS + \beta \cdot WS) \quad (11)$$

Where E^S is the soak emission, l_{trip} = the average trip length, and HS and WS are the hot and warm soak emission factors, respectively.

Average maximum and minimum temperatures per month are used in combination with diurnal emission factors to estimate the diurnal emissions from both carburettor and catalyst vehicles E^D :

$$E_{j,y}^D = 365 \cdot N_{j,y} \cdot e^D \quad (12)$$

Each year's total is the sum of each layer's running loss, soak loss and diurnal emissions.

Fuel consumption balance

The calculated fuel consumption in COPERT 5 must equal the statistical fuel sale totals according to the UNFCCC and UNECE emissions reporting format. The statistical fuel sales for road transport are derived from the Danish Energy Authority data (see DEA, 2021a).

For gasoline, the DEA sales data for road transport are adjusted at first, in order to account for e.g. non-road and recreational craft fuel consumption, which are not directly stated in the statistics. Please refer to paragraph 3.3.3 for further information regarding the transformation of DEA fuel data. Next, the fuel and emission results for all gasoline vehicles are scaled with the percentage difference between the bottom-up gasoline fuel consumption on Danish roads and total gasoline fuel sold.

The DEA data for diesel consist of fuel sold in Denmark and used on Danish roads and fuel sold in Denmark and used abroad (diesel border sales). The latter diesel fuel contribution is estimated by the Danish Ministry of Taxation based on studies on fuel price differences across borders, fuel discount for haulage contractors and fuel tanking behavior of truck and bus operators as well as private cars (see e.g. the Danish Ministry of Taxation, 2015).

The diesel border sales (diesel used abroad) is allocated to truck-trailer and articulated trucks (TT/AT trucks) in two total vehicle weight categories, < 40 tonnes and > 40 tonnes, and coaches.

The distribution of the diesel used abroad is split into the three vehicle categories by using the relative fuel consumption used in Denmark by foreign TT/AT trucks (< 40 tonnes and > 40 tonnes) and coaches (calculated based on mileage driven in Denmark by foreign trucks and coaches (paragraph 3.3.2) and corresponding fuel consumption factors).

The calculated "border" scaling factors of the TT/AT trucks and coaches in the model, i.e. the ratio between the total model fuel consumption (model fuel

consumption in Denmark and model fuel consumption abroad) and the model fuel consumption in Denmark for these vehicle categories are shown in (Figure 3.3.25).

The total model fuel consumption for all vehicle categories is subsequently calculated in a first step, as the product of fuel consumption factors and corresponding total mileage, the latter being adjusted for mileage driven outside Denmark, as described above in the case of TT/AT trucks and coaches (adjusted bottom up diesel fuel consumption).

Next, the percentage difference between the first step model diesel fuel consumption (adjusted bottom up diesel fuel consumption) and the total diesel fuel sold in Denmark is used to scale fuel and emission results for all diesel vehicles regardless of vehicle category (Figure 3.3.26). The data behind the Figures 3.3.25 and 3.3.26 are also listed in Annex 3.B.8.

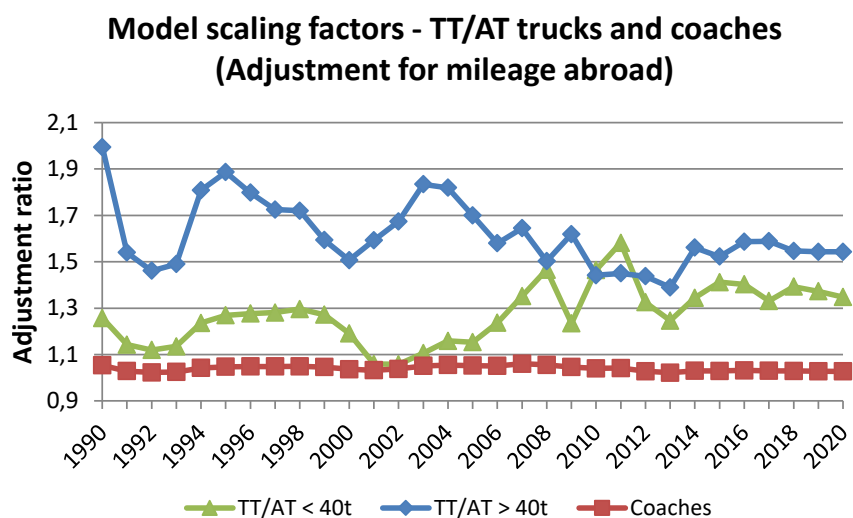

Figure 3.3.25 Fuel and emission adjustment ratios for TT/AT trucks and coaches: Bottom-up fuel consumption plus diesel used abroad vs bottom-up fuel consumption.

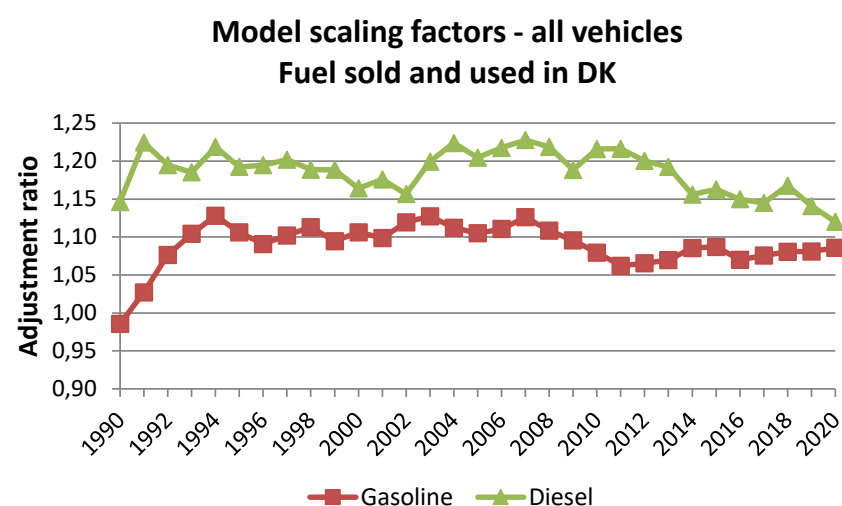

Figure 3.3.26 Gasoline and diesel fuel ratios (fuel and emission adjustment factors) regardless of vehicle category: Fuel sold and used in Denmark vs bottom-up fuel consumption used in Denmark.

The reasons for the differences between DEA sales figures and bottom-up fuel estimates shown in Figure 3.3.26 are mostly due to a combination of the uncertainties related to COPERT 5 fuel consumption factors, allocation of vehicle numbers in sub-categories, annual mileage, trip speeds and mileage splits for urban, rural and highway driving conditions.

The final fuel consumption and emission factors are shown in Annex 3.B.7 for 1985-2020. The total fuel consumption and emissions are shown in Annex 3.B.8, per vehicle category and as grand totals, for 1985-2020 (and CRF format in Annex 3.B.16. In Annex 3.B.15, fuel consumption and emission factors as well as total emissions are given in CollectER format for 1990 and 2020.

In the following Figures 3.3.27 - 3.3.29, the fuel and km related emission factors for CO₂ (km related only), CH₄ and N₂O are shown per vehicle type for the Danish road transport (from 1990-2020).

For CO₂ the neat gasoline/diesel emission factors shown in Table 3.3.7 are country specific values, and come from the DEA. In 2006 and 2008, respectively, bio ethanol and biodiesel became available from a limited number of gas filling stations in Denmark, and today bio ethanol and biodiesel (FAME) is added to all fuel commercially available. Following the IPCC guideline definitions, bio fuels are in principle regarded as CO₂ neutral for the transport sector as such. A small part of carbon (and the associated CO₂ emissions) in biodiesel, however, have a fossil origin due to the use of fossil-derived methanol in the biodiesel production process. This is accounted for in the emission inventories by following the biodiesel fossil carbon content calculation methodology provided by Sempos (2019).

The sulphur content for bio ethanol/biodiesel is assumed to be zero and hence, the aggregated CO₂ (and SO₂) factors for gasoline/diesel have been adjusted, on the basis of the energy content of neat gasoline/diesel and bio ethanol/biodiesel, respectively, in the available fuels.

At present, the Danish road transport fuels only have low biofuel (BF) shares (Table 3.3.7), and hence, no thermal efficiency changes are expected for the fuels. Consequently, the energy based fuel consumption factors (MJ/km) derived from COPERT 5 are used also in this case.

As a function of the current ethanol/biodiesel energy percentage, BF%_E, (Table 3.3.7) the average fuel related CO₂ emission factors, emf_{CO₂,E}(BF%) become:

$$EF_{CO_2,E}(BF\%) = EF_{CO_2,E}(BF0) \cdot (100 - BF\%_E) \quad (13)$$

Where:

EF_{CO₂,E}(BF%) = average fuel related CO₂ emission factor (g MJ⁻¹) for current BF%

EF_{CO₂,E}(BF0) = fuel related CO₂ emission factor (g MJ⁻¹) for fossil fuels

The kilometer based average CO₂ emission factor is subsequently calculated as the product of the fuel related CO₂ emission factor from equation 3 and the energy based fuel consumption factor, FC_{CO₂,E}(BF0), derived from COPERT 5:

$$EF_{CO_2,km}(BF\%) = EF_{CO_2,E}(BF\%) \cdot FC_E(BF0) \quad (14)$$

A literature review carried out in the Danish research project REBECA revealed no significant changes in emission factors between neat gasoline and E5 gasoline-ethanol blends for the combustion related emission components; NO_x, CO and VOC (Winther et al., 2012). Hence, due to the current low ethanol content in today's road transport gasoline, no modifications of the neat gasoline based COPERT emission factors are made in the inventories in order to account for ethanol usage.

REBECA results published by Winther (2009) have shown that the emission impact of using diesel-biodiesel blends is very small at low biodiesel blend ratios. Consequently, no bio fuel emission factor adjustments are needed for diesel vehicles as well. However, adjustment of the emission factors for diesel vehicles will be made if the biodiesel content of road transport diesel fuel increases to a more significant level in the future.

The fuel related CO₂ emission factors for neat gasoline/diesel, bio ethanol/biodiesel, and aggregated CO₂ factors are shown in Table 3.3.7. For gasoline and compressed natural gas (CNG) the CO₂ emission factors are country-specific. For gasoline the emission factor source is Fenhann and Kilde (1994). For CNG, the CO₂ emission factor is estimated by the Danish gas transmission company, Energinet.dk, based on gas analysis data. For liquefied petroleum gas (LPG), the emission factor source is EMEP/EEA (2019). For diesel the emission factor source is IPCC (2006).

Table 3.3.7 Fuel-specific CO₂ emission factors and biofuel shares for road transport in Denmark.

Fuel type	Emission factors (g/MJ)															
	1990-2005	2006	2007	2008	2009	2010	2011	2012	2013	2014	2015	2016	2017	2018	2019	2020
Neat diesel	74.1	74.1	74.1	74.1	74.1	74.1	74.1	74.1	74.1	74.1	74.1	74.1	74.1	74.1	74.1	74.1
Neat gasoline	73	73	73	73	73	73	73	73	73	73	73	73	73	73	73	73
LPG	63.1	63.1	63.1	63.1	63.1	63.1	63.1	63.1	63.1	63.1	63.1	63.1	63.1	63.1	63.1	63.1
Biodiesel	4.2	4.2	4.2	4.2	4.2	4.2	4.2	4.2	4.2	4.2	4.2	4.2	4.2	4.2	4.2	4.2
Bio ethanol	0	0	0	0	0	0	0	0	0	0	0	0	0	0	0	0
Diesel avg.	74.1	74.1	74.1	74.1	74.0	74.1	71.8	69.7	69.5	69.5	69.6	69.6	69.8	69.9	69.5	69.5
Gasoline avg.	73	72.9	72.8	72.8	72.8	71.8	70.7	70.5	70.6	70.6	70.7	70.7	70.7	70.7	70.7	68.4
Biofuel share (BF%) of Danish road transport fuels																
	1990-2005	2006	2007	2008	2009	2010	2011	2012	2013	2014	2015	2016	2017	2018	2019	2020
	0	0.07	0.11	0.10	0.16	0.54	2.63	4.28	4.38	4.46	4.39	4.38	4.30	4.22	4.56	5.40

CO₂ emission factors - cars & vans & 2-wheelers

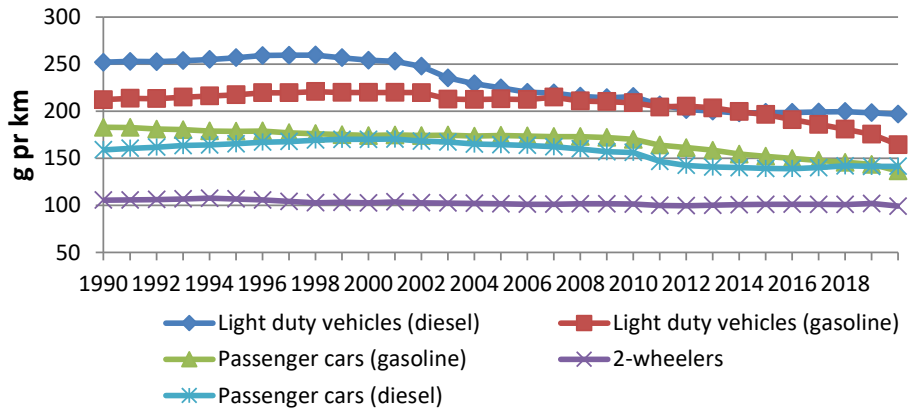

CO₂ emission factors - heavy duty vehicles

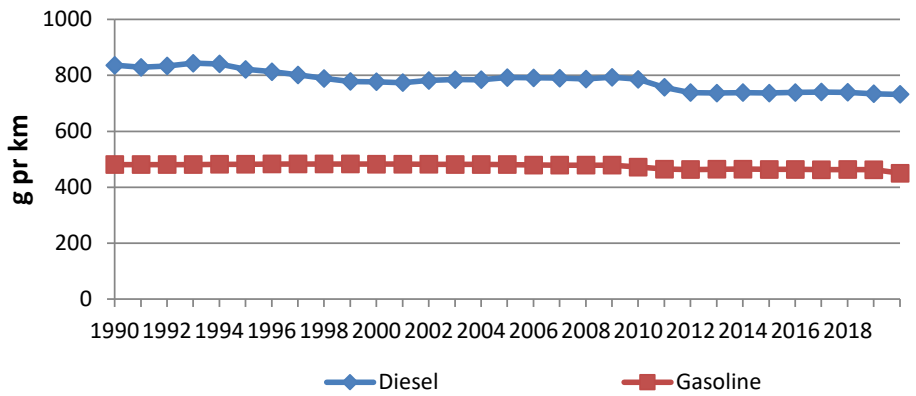
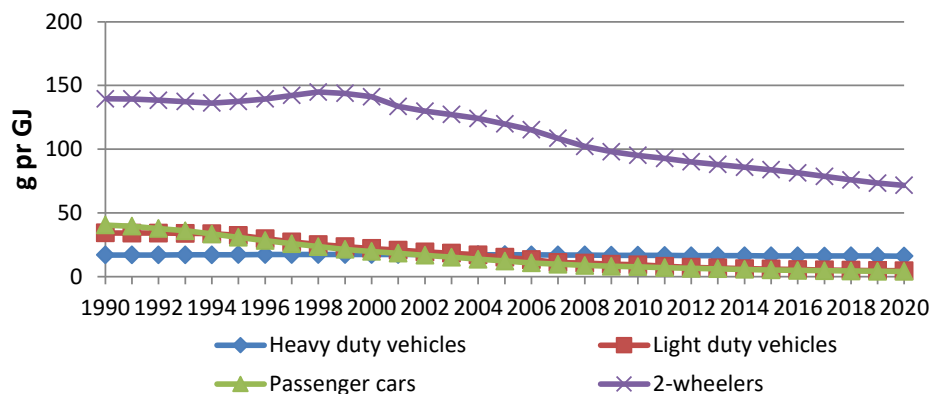
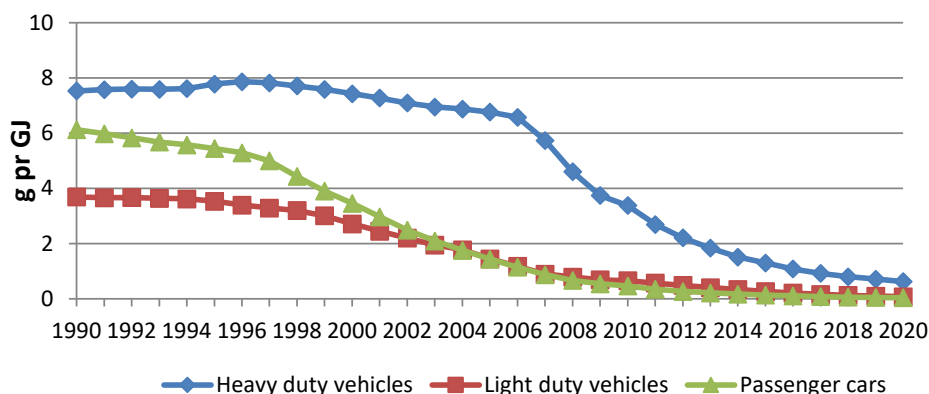

Figure 3.3.27 Km related CO₂ emission factors per vehicle type for Danish road transport (1990-2020).

CH₄ emission factors - gasoline vehicles



CH₄ emission factors - diesel vehicles



CH₄ emission factors - gasoline vehicles

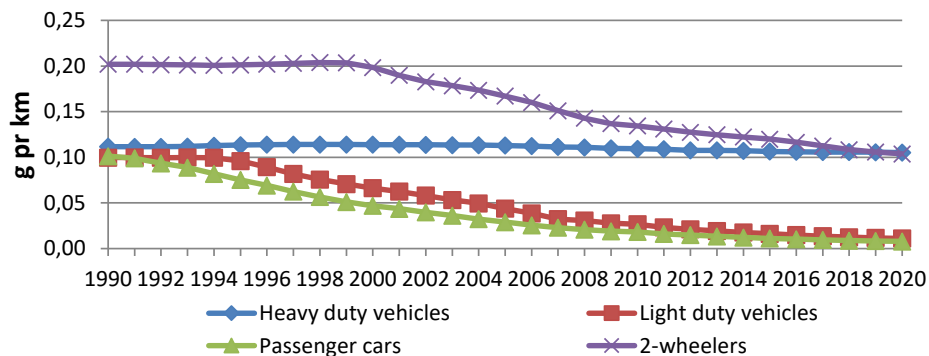

CH₄ emission factors - diesel vehicles

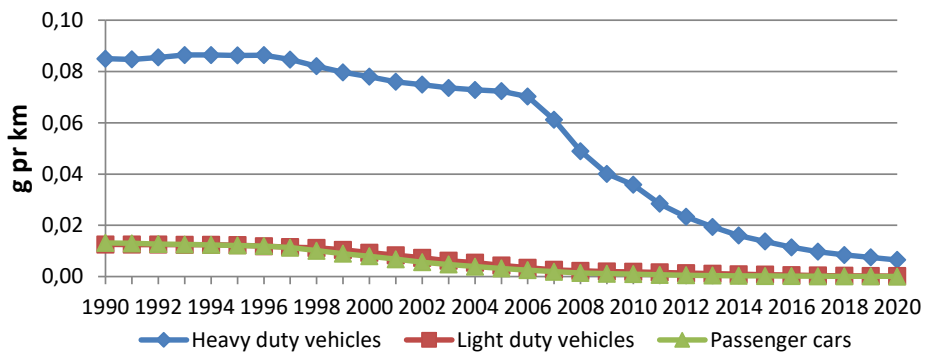
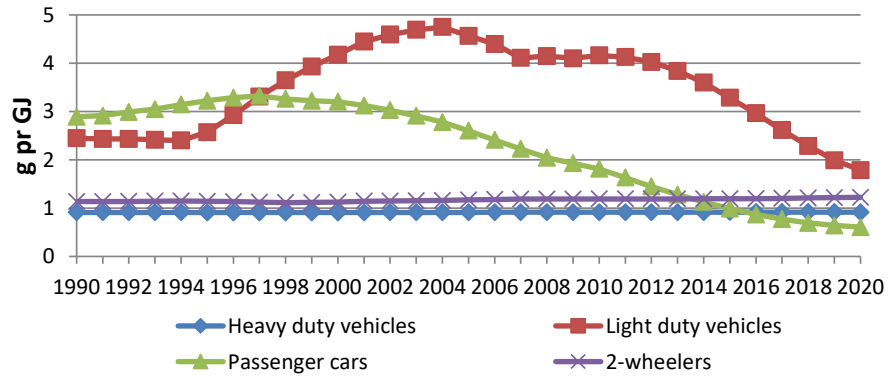
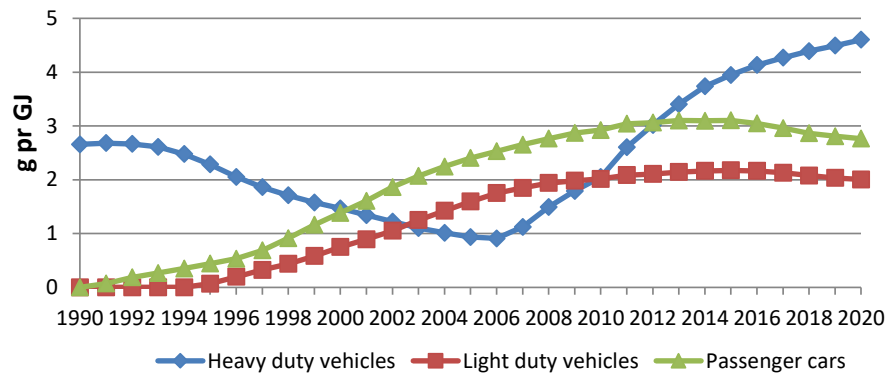

Figure 3.3.28 Fuel and km related CH₄ emission factors per vehicle type for Danish road transport (1990-2020).

N₂O emission factors - gasoline vehicles



N₂O emission factors - diesel vehicles



N₂O emission factors - gasoline vehicles

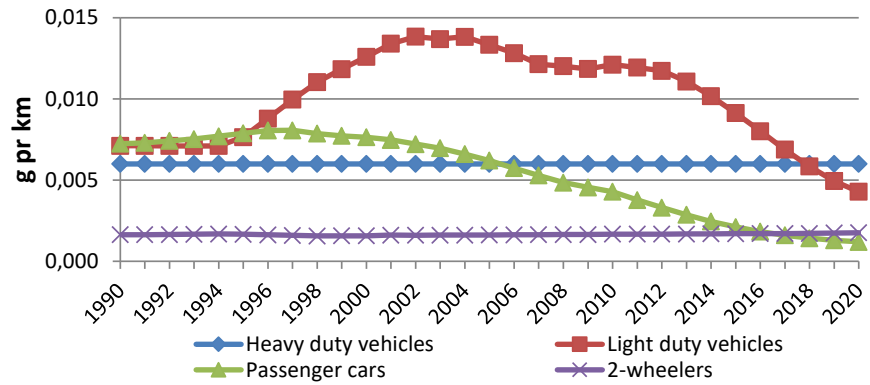

N₂O emission factors - diesel vehicles

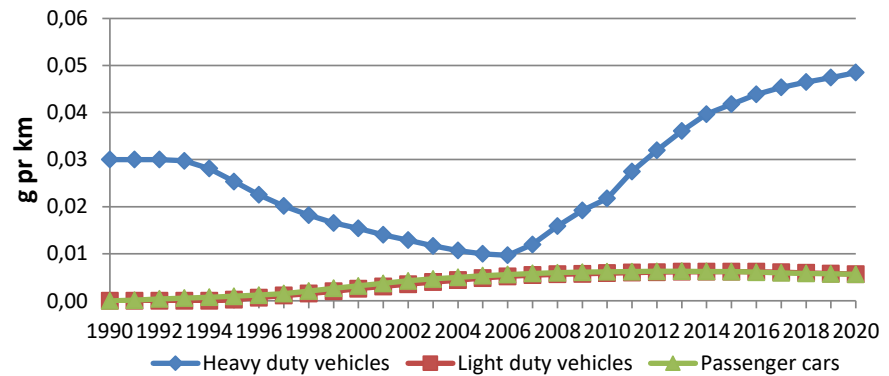

Figure 3.3.29 Fuel and km related N₂O emission factors per vehicle type for Danish road transport (1990-2020).

Methodologies and references for other mobile sources

Other mobile sources are divided into several sub-sectors: sea transport, fishery, air traffic, railways, military, and working machinery and equipment in the sectors agriculture, forestry, industry and residential. The emission calculations are made in internal DCE models using the detailed method as described in the EMEP/EEA air pollutant emission inventory guidebook (EMEP/EEA, 2019) for air traffic, off-road working machinery and equipment, and ferries, while for the remaining sectors the simple method is used.

3.3.3 Activity data

Air traffic

The activity data used in the DCE emission model for aviation consists of air traffic statistics provided by the Danish Transport and Construction Agency and Copenhagen Airport. Fuel statistics for jet fuel consumption and aviation gasoline are obtained from the Danish energy statistics (DEA, 2021a).

For 2001 onwards, the Danish Transport and Construction Agency provides data records per flight (city-pairs). Each flight record consists of e.g. ICAO codes for aircraft type, origin and destination airport, maximum takeoff mass (MTOM), flight call sign and aircraft registration number.

In the DCE model, each aircraft type is paired with a representative aircraft type, for which fuel consumption and emission data exist in the EMEP/EEA databank. As a basis, the type relation table is taken from the Eurocontrol AEM model, which is the primary source for the present EMEP/EEA fuel consumption and emission data. Supplementary aircraft types are assigned to representative aircraft types based on the type relation table already established in the previous version of the DCE model (e.g. Winther, 2020).

Additional aircraft types not present in the type relation table are identified by using different aircraft dictionaries and internet look-ups. In order to select the most appropriate aircraft representative type, the main selection criteria are the identified aircraft type, aircraft maximum takeoff mass, engine types, and number of engines. During this sequence, small aircraft with piston engines using aviation gasoline are excluded from the calculations.

Annex 3.B.10 shows the correspondence table between the actual aircraft type codes and representative aircraft types behind the Danish inventory. Annex 3.B.10 also show the number of LTO's per representative aircraft type for domestic and international flights starting from Copenhagen Airport and other airports, respectively¹¹, in a time series from 2001-2020. The airport split is necessary to make due to the differences in LTO emission factors (cf. section 3.3.4).

The same type of LTO activity data for the flights for Greenland and the Faroe Islands are shown in Annex 3.B.10 also, further detailed into origin-destination airport pairs and associated flight distances. This level of detail meets the demand from UNFCCC to provide precise documentation for the part of the inventory for the Kingdom of Denmark being outside the Danish mainland.

¹¹ Excluding flights for Greenland and the Faroe Islands. These flights are separately listed in Annex 3.B.10.

The ideal flying distance (great circle distance) between the city-pairs is calculated by DCE in a separate database. The calculation algorithm uses a global latitude/altitude coordinate table for airports. In cases when airport coordinates are not present in the DCE database, these are looked up on the internet and entered into the database accordingly. The actual distance flown are in reality longer than great circle distance between two airports, and this is adjusted for in the DCE emission model, as explained in section 3.3.4.

For inventory years prior to 2001, detailed LTO/aircraft type statistics are obtained from Copenhagen Airport (for this airport only), while information of total takeoff numbers for other Danish airports is provided by the Danish Transport and Construction Agency. The assignment of representative aircraft types for Copenhagen Airport is done as described above. For the remaining Danish airports, representative aircraft types are not directly assigned. Instead, appropriate average assumptions are made relating to the fuel consumption and emission data part.

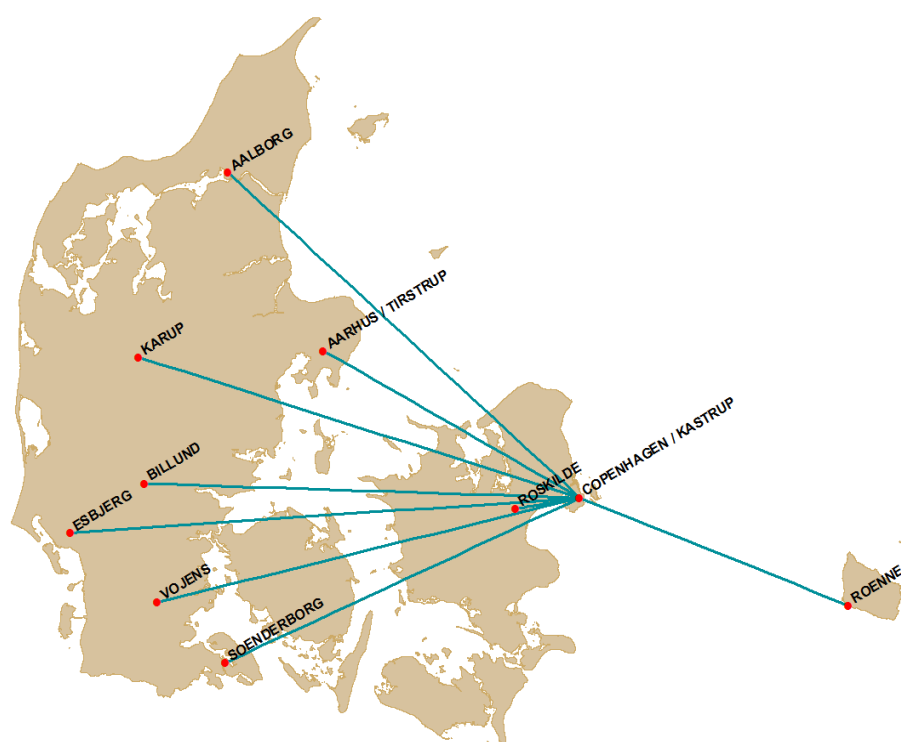

Figure 3.3.30 Most frequent domestic flying routes for large aircraft in Denmark.

Copenhagen Airport is the starting or end point for most of the domestic aviation made by large aircraft in Denmark (Figure 3.3.30; routes to Greenland/Faroe Islands are not shown). Even though many domestic flights not touching Copenhagen Airport are also reported in the flight statistics kept by the Danish Transport and Construction Agency, these flights, however, are predominantly made with small piston engine aircraft using aviation gasoline. Hence, the consumption of jet fuel by flights not using Copenhagen Airport is merely marginal.

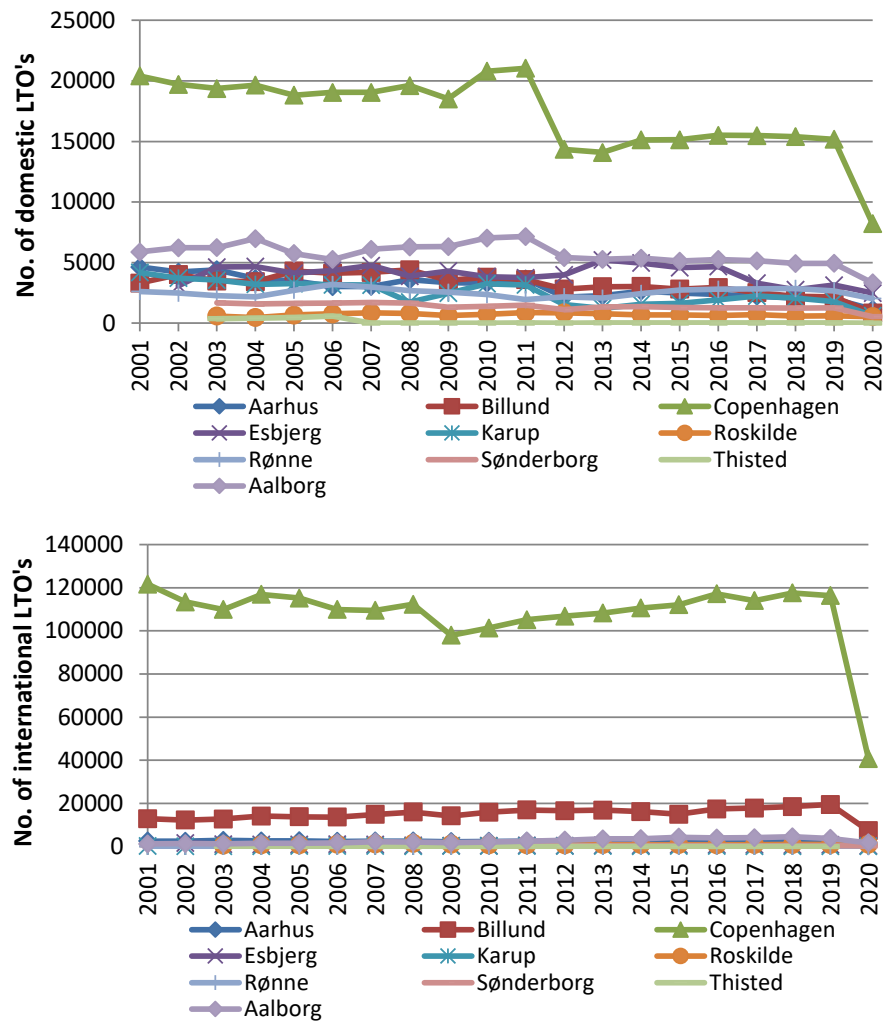

Figure 3.3.31 No. of LTO's for the most important airports in Denmark 2001-2020.

Figure 3.3.31 shows the number of domestic and international LTO's for Danish airports¹², in a time series from 2001-2020.

Non-road working machinery and equipment

Non-road working machinery and equipment are used in agriculture, forestry and industry, for household/gardening purposes and for sailing purposes (recreational craft).

Detailed tractor fleet data for 2003-2020 and total numbers 1950-2002 for tractors in the Danish motor register are provided by Statistics Denmark (2021a, 2021b).

Total numbers for tractors (tractors in motor register and other tractors) for 1982-2005 are provided by Statistics Denmark (2021c). Total numbers for tractors (tractors in motor register and other tractors) for 1974-1981 are found in consecutive statistical publications e.g. Agricultural statistics 1974 (Statistics Denmark, 1975), as well as supplementary stock numbers per fuel type (diesel and gasoline).

¹² Flights for Greenland and the Faroe Islands are included under domestic in the figure.

Supplementary new sales data in kW classes are provided by the Association of Danish Agricultural Machinery Dealers for 1982-2018. Engine load factors and annual working hours for tractors come from Bak et al. (2003).

Number of forestry machines, engine size, annual working hours and average life times are provided by the Danish Forest Association (Clemmensen, 2021).

For the most important types of building and construction machinery (industrial non-road) annual new sales data for 1996 onwards has been provided by the Association of Danish Agricultural Machinery Dealers (Fasting, 2021).

Fork lift sales data has been provided by the Association of Producers and Distributors of Fork Lifts in Denmark for 1976-2019. Further, WITS (World Industrial Truck Sales) and FEM (Federation European Material) fork lift sales figures for Denmark in 2000-2020 as well as branch distribution information has been provided by Toyota Material Handling (Christensen, 2021).

For telescopic loaders, branch distribution information has been provided by Scantruck (Faurby, 2021).

From engine manufacturers engine load factors have been provided based on electronic engine power registrations (Sjøgren 2016; Mikkelsen 2016) in the case of building and construction machinery. Further, equipment size - engine size relations, equipment scrapping curves and annual working hours as a function of machinery age has been included in the model (Sjøgren 2016; Mikkelsen 2016; Brun 2018; Christensen 2018).

For the most important household and gardening machinery types, annual new sales data for 2006 onwards is provided by the Association for Industrial Technics, Tools and Automation (BITVA: Brancheforeningen for industriel teknik, værktøj og automation). Until 2018 new sales data was provided by the Dealers Association of Electric Tools and Gardening Machinery (LTEH: Leverandørforeningen for Transportabelt Elværktøj og Havebrugsmaskiner). Further, equipment size - engine size relations, equipment scrapping curves and annual working hours as a function of machinery age has been provided by LTEH (Nielsen and Schösser, 2016).

For other machinery types, information on the number of different types of machines, their respective load factors, engine sizes and annual working hours has been provided by Winther et al. (2006) for the years until 2004.

The stock development from 1990-2020 for the most important types of machinery are shown in Figures 3.3.32-3.3.39 below. The stock data are also listed in Annex 2.B.11, together with figures for load factors, engine sizes and annual working hours. As regards stock data for the remaining machinery types, please refer to (Winther et al., 2006).

It is important to note that key experts within the field of industrial non-road activities assume a significant decrease in the activities for 2009 due to the global financial crisis. This reduction is in the order of 25 % for 2009 for industrial non-road in general (pers. comm. Per Stjernqvist, Volvo Construction Equipment 2010). For fork lifts, 5 % and 20 % reductions are assumed for 2008 and 2009, respectively (pers. comm. Peter H. Møller, Rocla A/S).

For agriculture, the total number of agricultural tractors and harvesters per year are shown in the Figures 3.3.32-3.3.33, respectively. The figures clearly show a decrease in the number of small machines, these being replaced by machines in the large engine-size ranges.

The agricultural tractor and harvester developments towards fewer vehicles and larger engines, shown in Figure 3.3.34, are very clear. From 1990 to 2020, tractor and harvester numbers decrease by around 47 % and 72 %, respectively, whereas the average increase in engine size for tractors is 92 % and 312 % for harvesters, in the same time period.

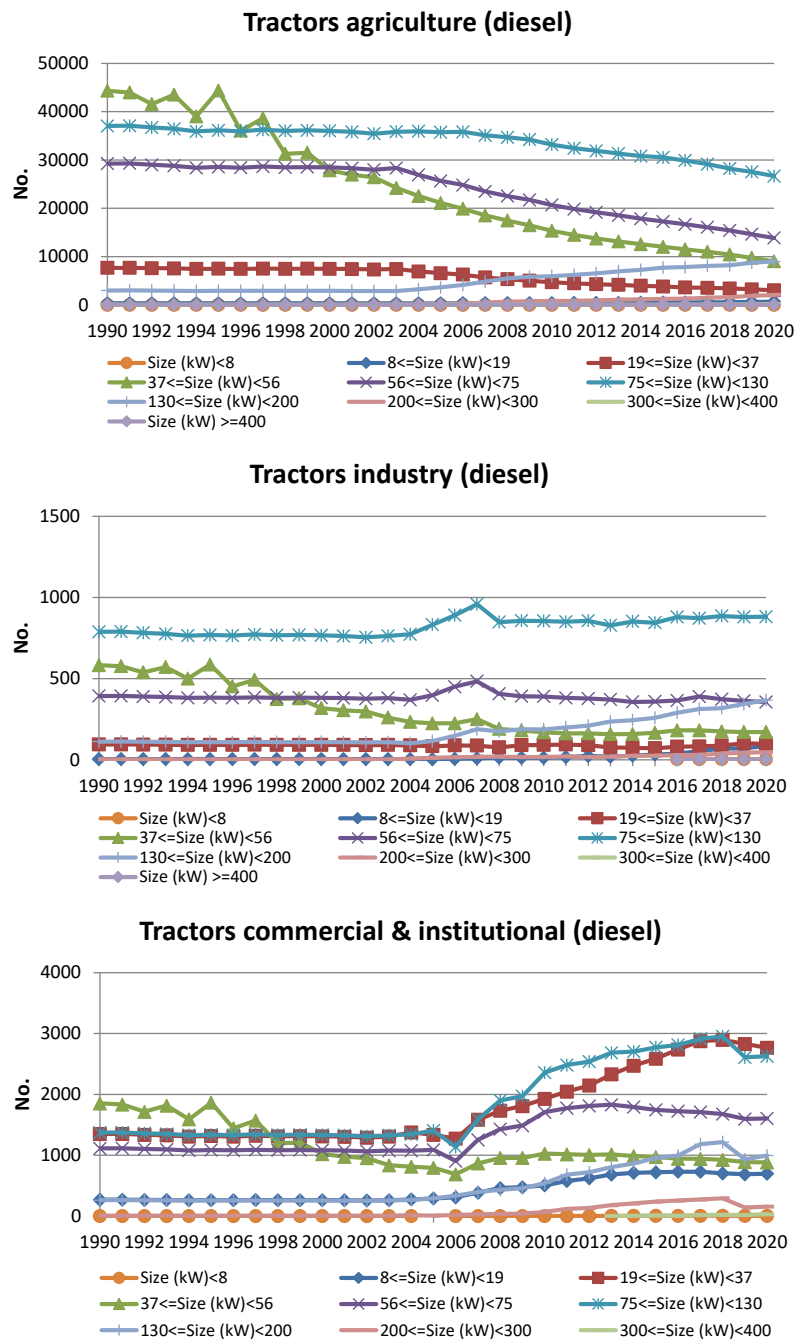

Figure 3.3.32 Total numbers in kW classes for tractors in agriculture, industry and commercial/institutional from 1990 to 2020.

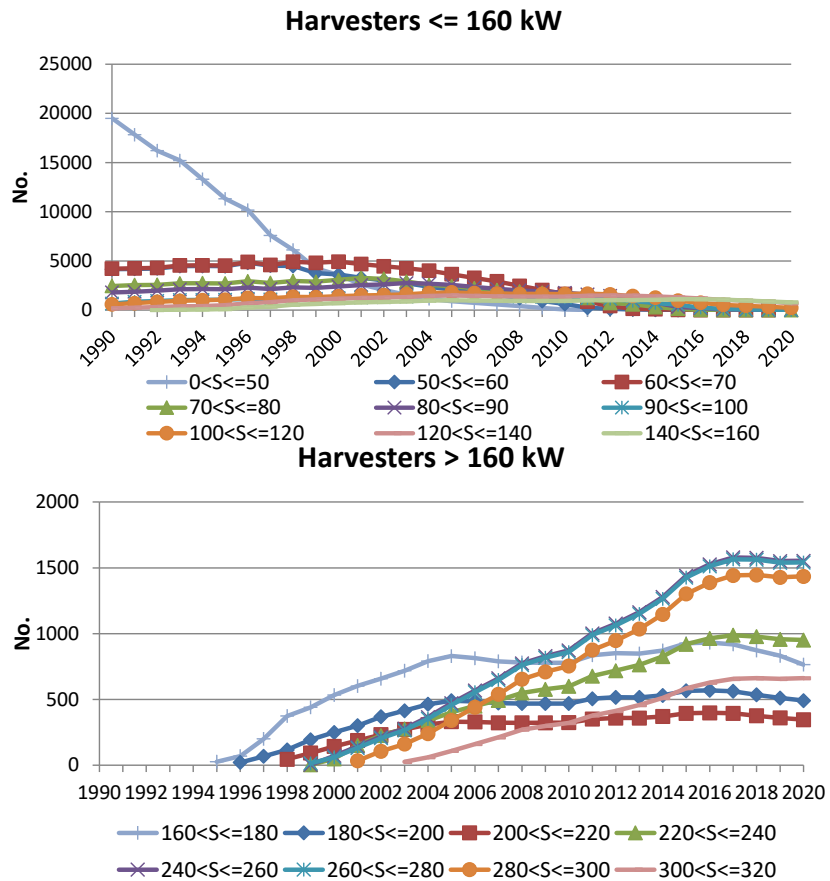

Figure 3.3.33 Total numbers in kW classes for harvesters from 1990 to 2020.

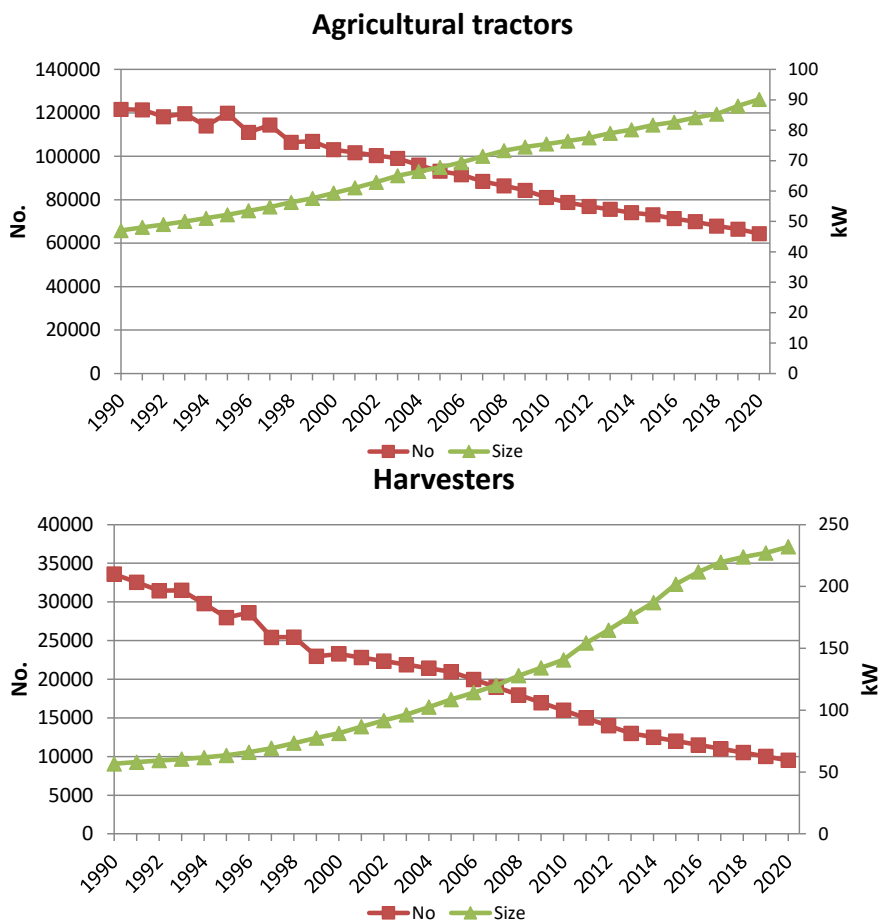

Figure 3.3.34 Total numbers and average engine size for agricultural tractors and harvesters (1990 to 2020).

The most important machinery types for industrial use are different types of construction machinery and fork lifts. The Figures 3.3.35 and 3.3.36 show the 1990-2020 stock development for specific types of construction machinery and diesel fork lifts. Due to lack of data, 1996-1999 average sales data for construction machinery is used for 1995 and back. However, it is assumed that telescopic loaders first enter into use in 1986 (Jensen, Scantruck 2016). For most of the machinery types, there is an increase in machinery numbers from 1990 onwards, due to increased construction activities.

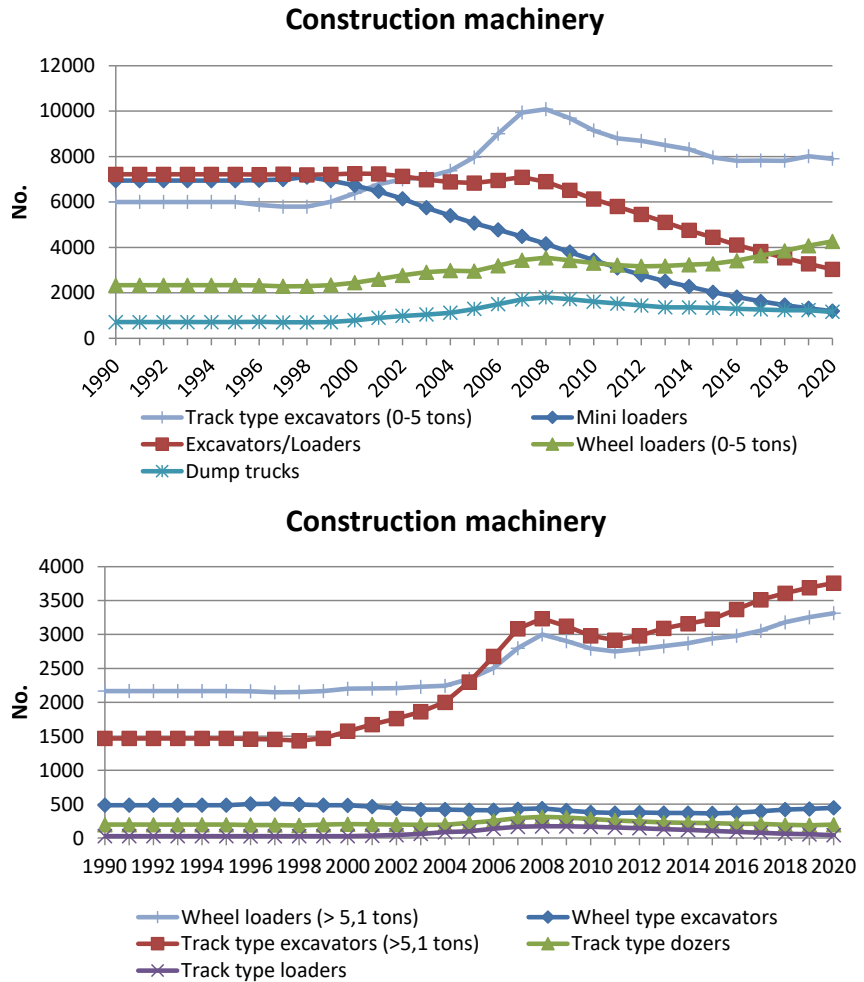

Figure 3.3.35 1990-2020 stock development for specific types of construction machinery.

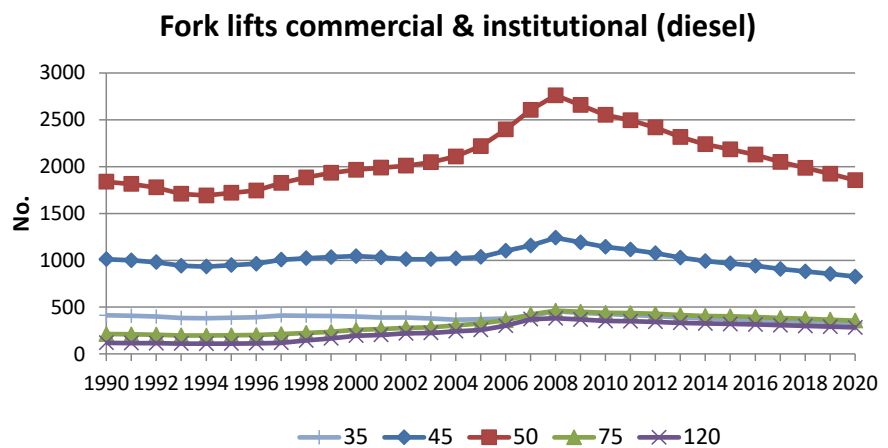
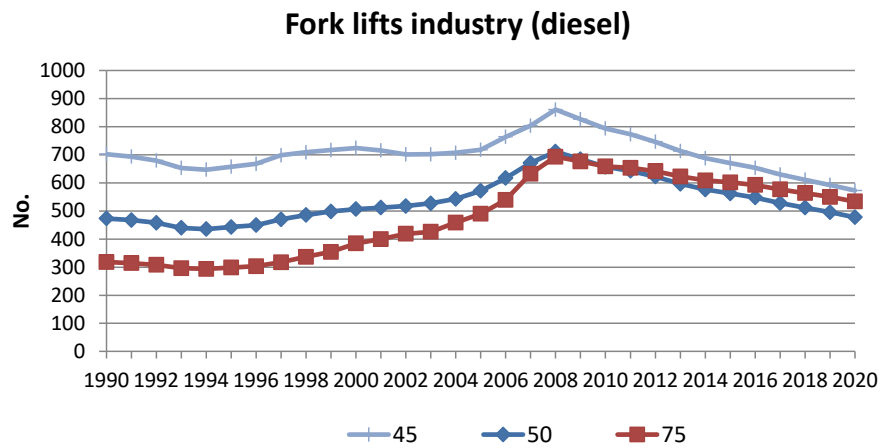

Figure 3.3.36 Total numbers of diesel fork lifts in kW classes from 1990 to 2020.

Figure 3.3.37 shows the emission layer distribution for the total stock of tractors, harvesters, construction machinery (most important types, Figure 3.3.35) and diesel fork lifts from 1990-2020.

The penetration of the different pre-Euro engine classes, and engine stages complying with the gradually stricter EU stage I-IV emission limits is very visible from Figure 3.3.37.

The EU emission directive stage implementation years relate to engine size, and hence, for all four machinery groups the emission level shares into specific size segments will differ slightly from the picture shown in Figure 3.3.37.

Tractors agriculture (diesel)

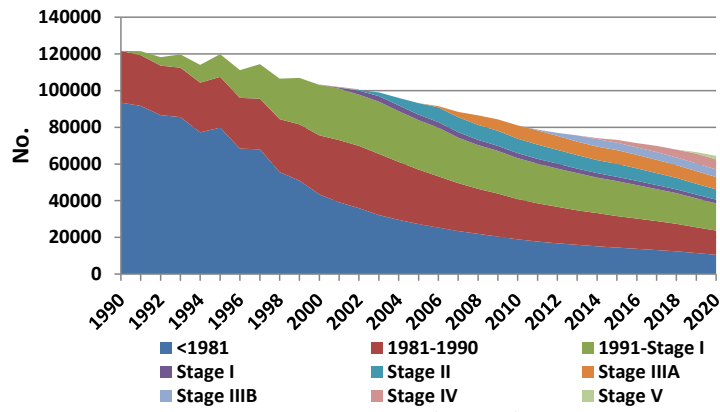

Tractors industry (diesel)

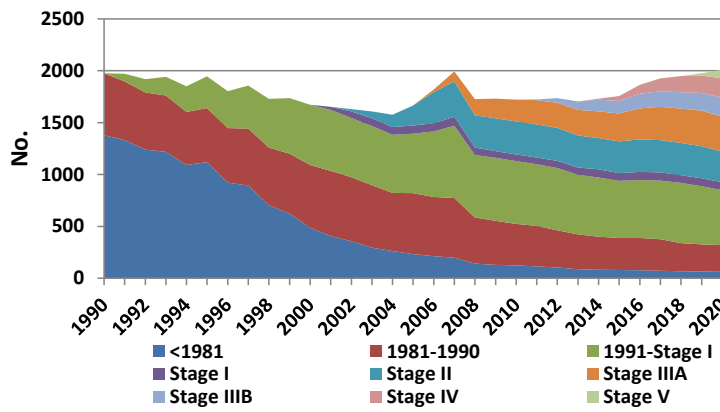

Tractors commercial & institutional (diesel)

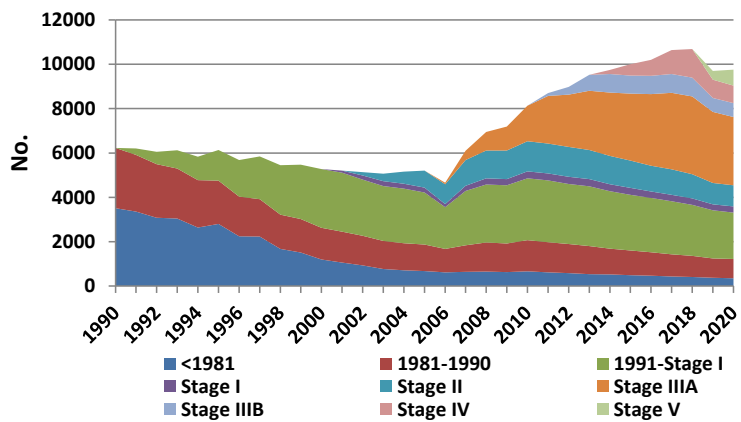

Harvesters

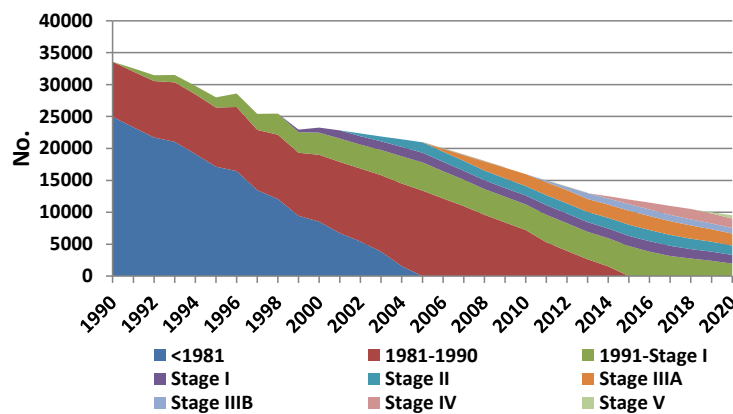

Continues next page...

Continued...

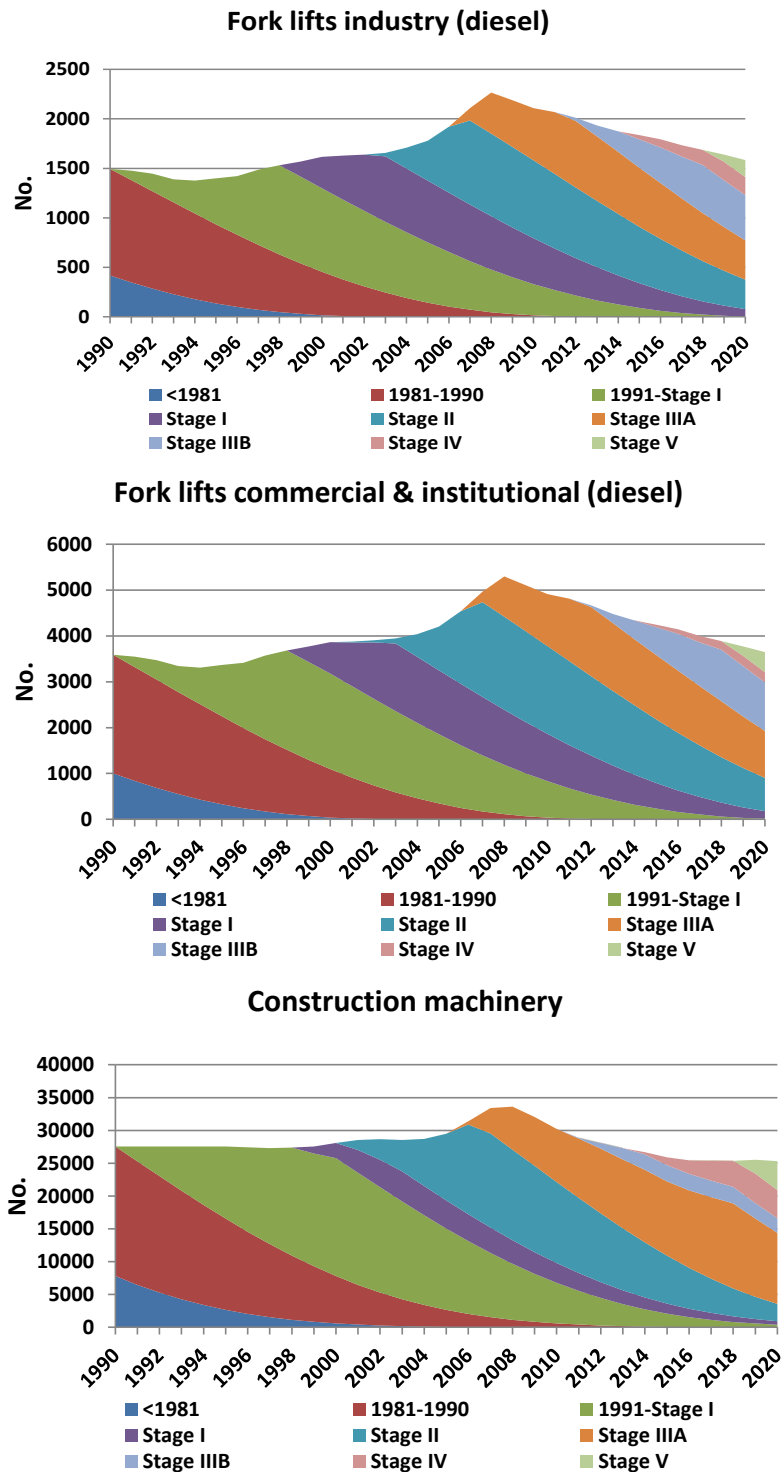

Figure 3.3.37 Layer distribution for tractors, harvesters, construction machinery and diesel fork lifts (1990 to 2020).

The 1990-2020 stock development for the most important household and gardening machinery types is shown in Figure 3.3.38. The activities made with private and professional equipment types are grouped into the Residential (1.A.4b) and Commercial/Institutional (1.A.4.a) inventory sectors, respectively.

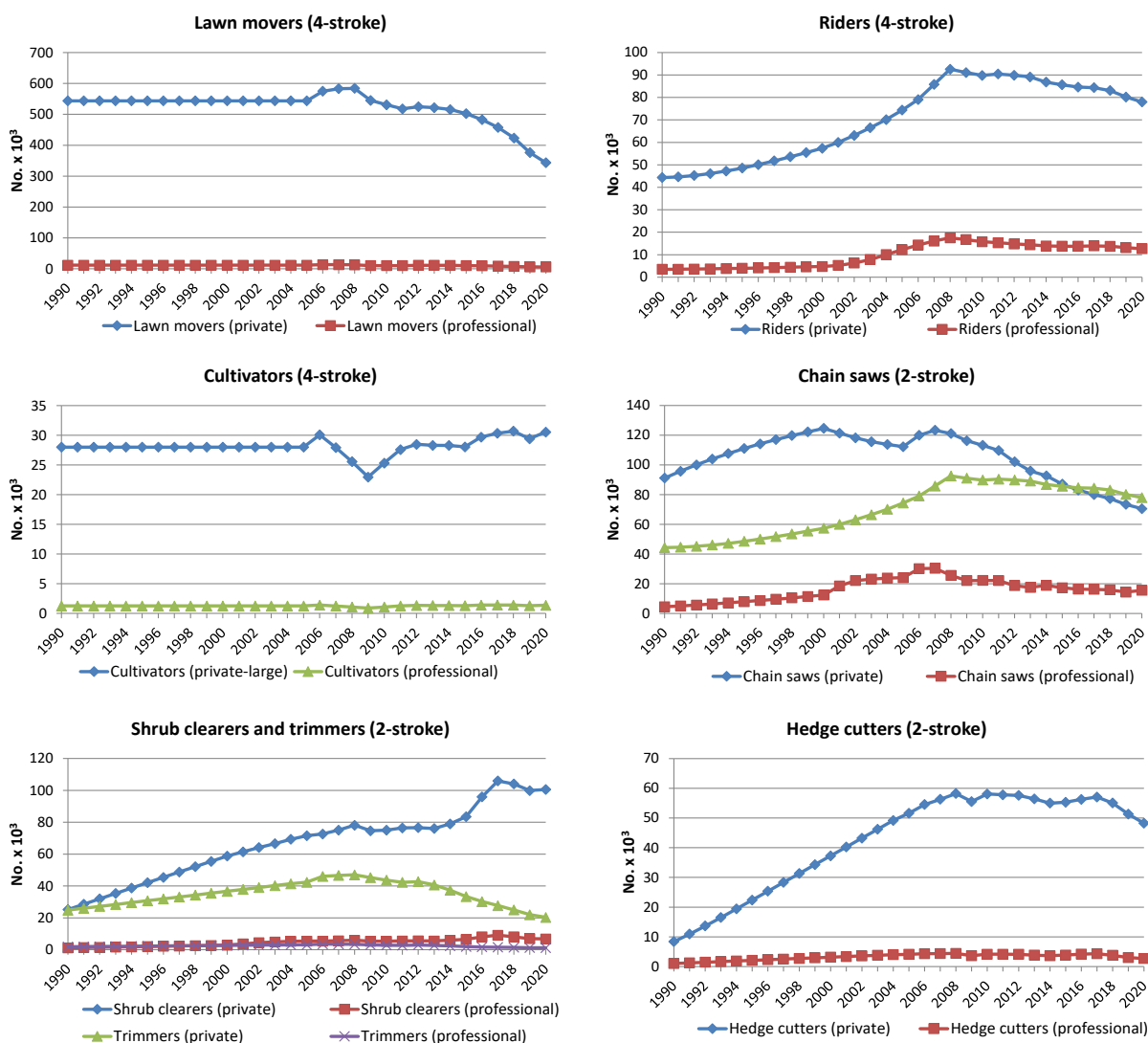

Figure 3.3.38 Stock development 1990-2020 for the most important household and gardening machinery types.

The total stock development for the most important household and gardening machinery types is shown in Figure 3.3.39 split into 2-stroke and 4-stroke machinery for Residential (1.A.4.b) and Commercial/Institutional (1.A.4.a). For the same stock division, the emission layer distribution is also shown in Figure 3.3.39. The penetration of new technologies occur faster for working machinery in Commercial/Institutional (1.A.4.a) compared with Residential (1.A.4.b), due to the shorter maximum life times for the working equipment used by professionals.

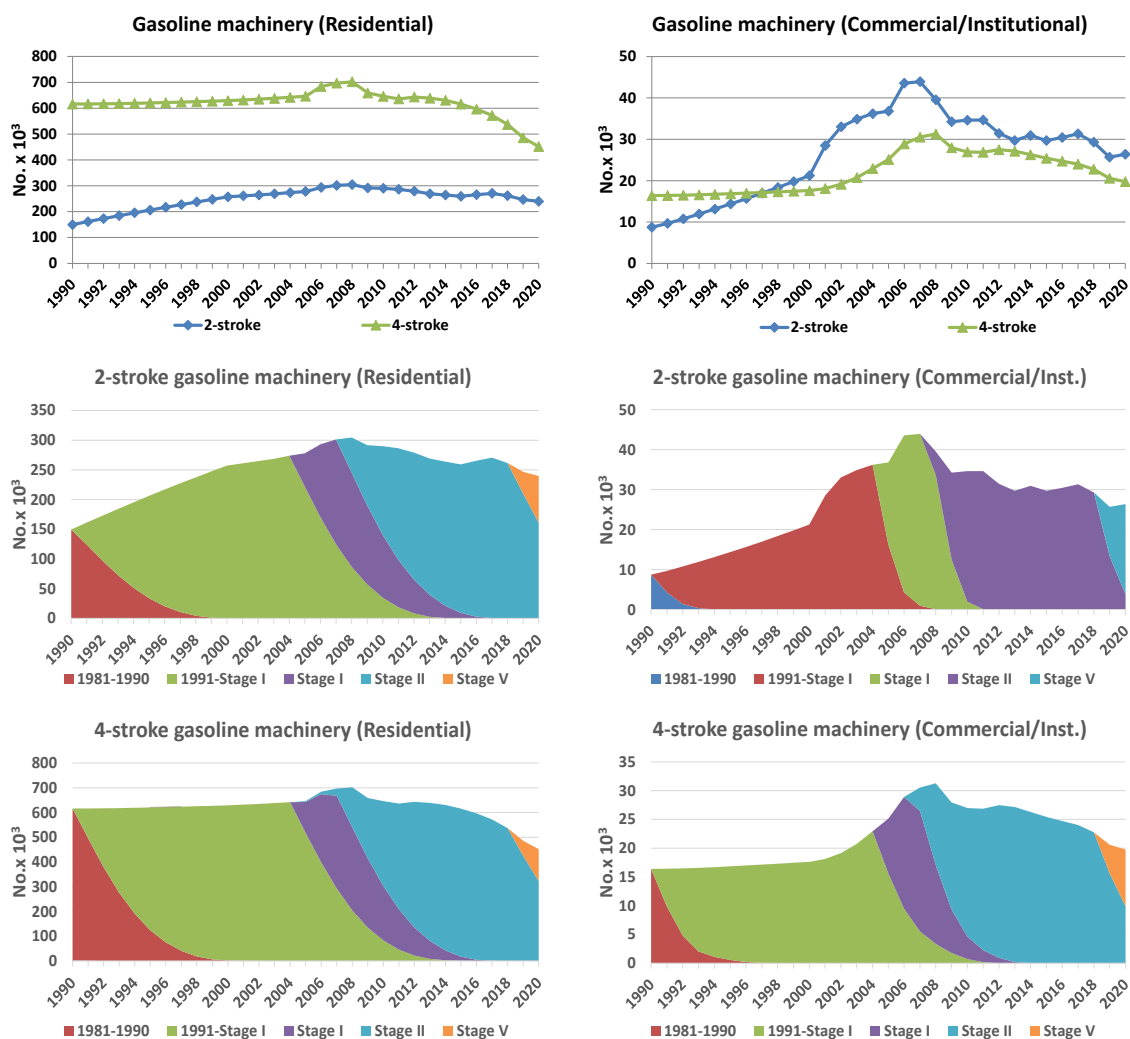

Figure 3.3.39 Layer distribution for the most important household and gardening machinery types split into residential and commercial/institutional (1990-2020).

Figure 3.3.40 shows the development in numbers of different recreational craft from 1990-2020. The 2004 stock data for recreational craft are repeated for 2005+, due to lack of data from the Danish Sailing Association.

For diesel boats, increases in stock and engine size are expected during the whole period, except for the number of motor boats (< 27 ft.) and the engine sizes for sailing boats (<26 ft.), where the figures remain unchanged. A decrease in the total stock of sailing boats (<26 ft.) by 21 % and increases in the total stock of yawls/cabin boats and other boats (<20 ft.) by around 25 % are expected. Due to a lack of information specific to Denmark, the shifting rate from 2-stroke to 4-stroke gasoline engines is based on a German non-road study (IFEU, 2004).

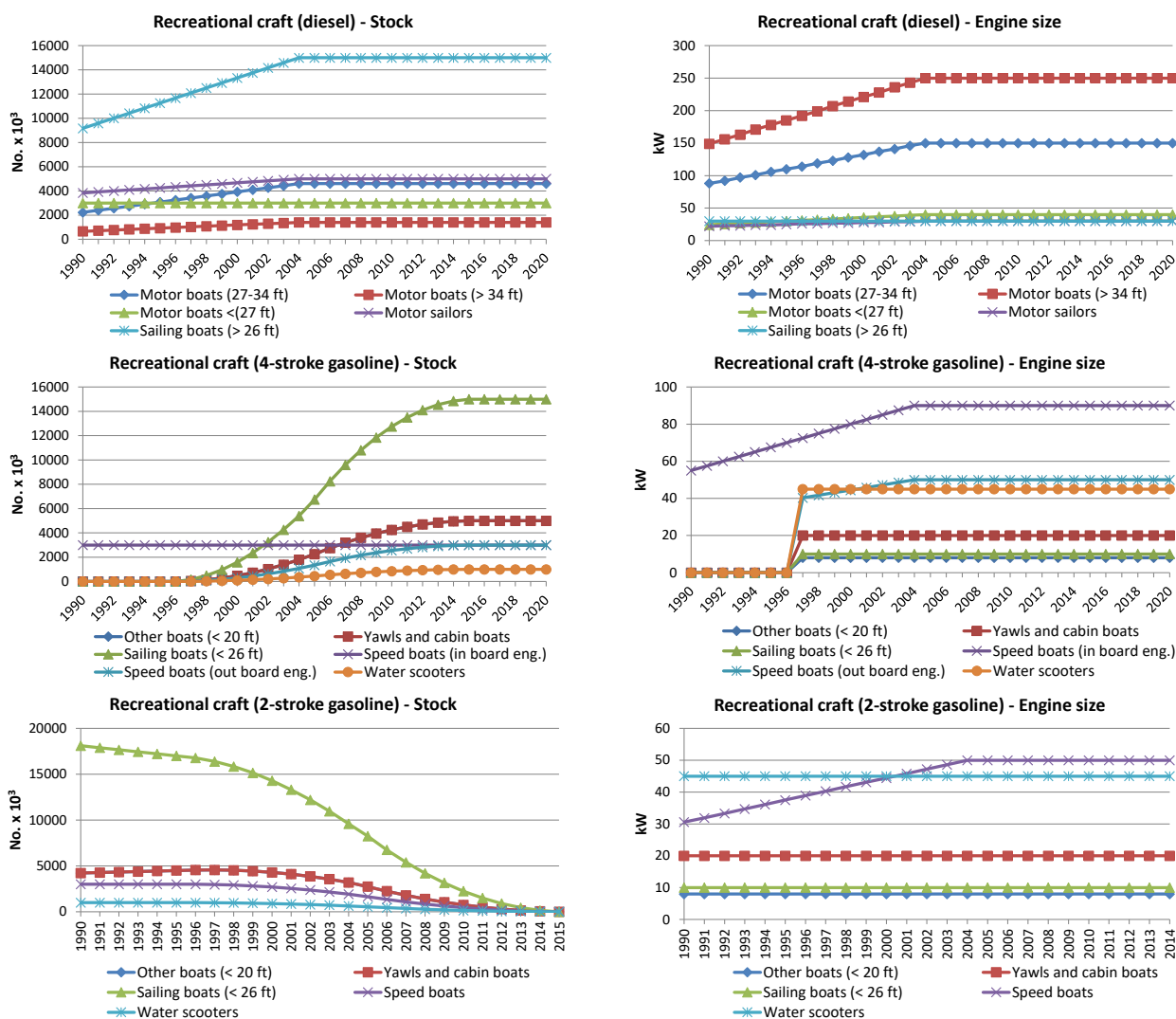

Figure 3.3.40 1990-2020 Stock and engine size development for recreational craft.

National sea transport

Table 3.3.8 lists the most important domestic ferry routes (regional ferries) in Denmark in the period 1990-2020. For these ferry routes and the years 1990-2005, the following detailed traffic and technical data have been gathered by Winther (2008): Ferry name, engine size (MCR), engine type, fuel type, average load factor, auxiliary engine size, share of annual trips and sailing time (single trip).

For 2006-2020, the above mentioned traffic and technical data for specific ferries have been provided by Nielsen (2021) in the case of Mols-Linien (Sjællands Odde-Ebeltoft, Sjællands Odde-Århus, Kalundborg-Århus, Køge-Rønne, Tårs-Spodsberg), by Jørgensen (2017) for Færgen A/S (Køge-Rønne, Tårs-Spodsberg, Kalundborg-Samsø), by Kruse (2015) for Samsø Rederi (Hou-Sælvig), by Mortensen (2015) for Færgeselskabet Læsø (Frederikshavn-Læsø) and by Eriksen (2017) for Ærøfærgerne (Svendborg-Ærøskøbing). For Esbjerg/Hanstholm/Hirtshals-Torshavn traffic and technical data have been provided by Dávastovu (2010).

Table 3.3.8 Regional ferry routes comprised in the Danish inventory.

Ferry service	Service period
Esbjerg-Torshavn	1990-1995, 2009+
Halsskov-Knudshoved	1990-1999
Hanstholm-Torshavn	1991-1992, 1999+
Hirtshals-Torshavn	2010
Hou-Sælvig	1990+
Hundested-Grenaa	1990-1996
Frederikshavn-Læsø	1990+
Kalundborg-Juelsminde	1990-1996
Kalundborg-Samsø	1990+
Kalundborg-Århus	1990+
Korsør-Nyborg, DSB	1990-1997
Korsør-Nyborg, Vognmandsruten	1990-1999
København-Rønne	1990-2004
Køge-Rønne	2004+
Sjællands Odde-Ebeltoft	1990+
Sjællands Odde-Århus	1999+
Svendborg-Ærøskøbing	1990+
Tårs-Spødsbjerg	1990+

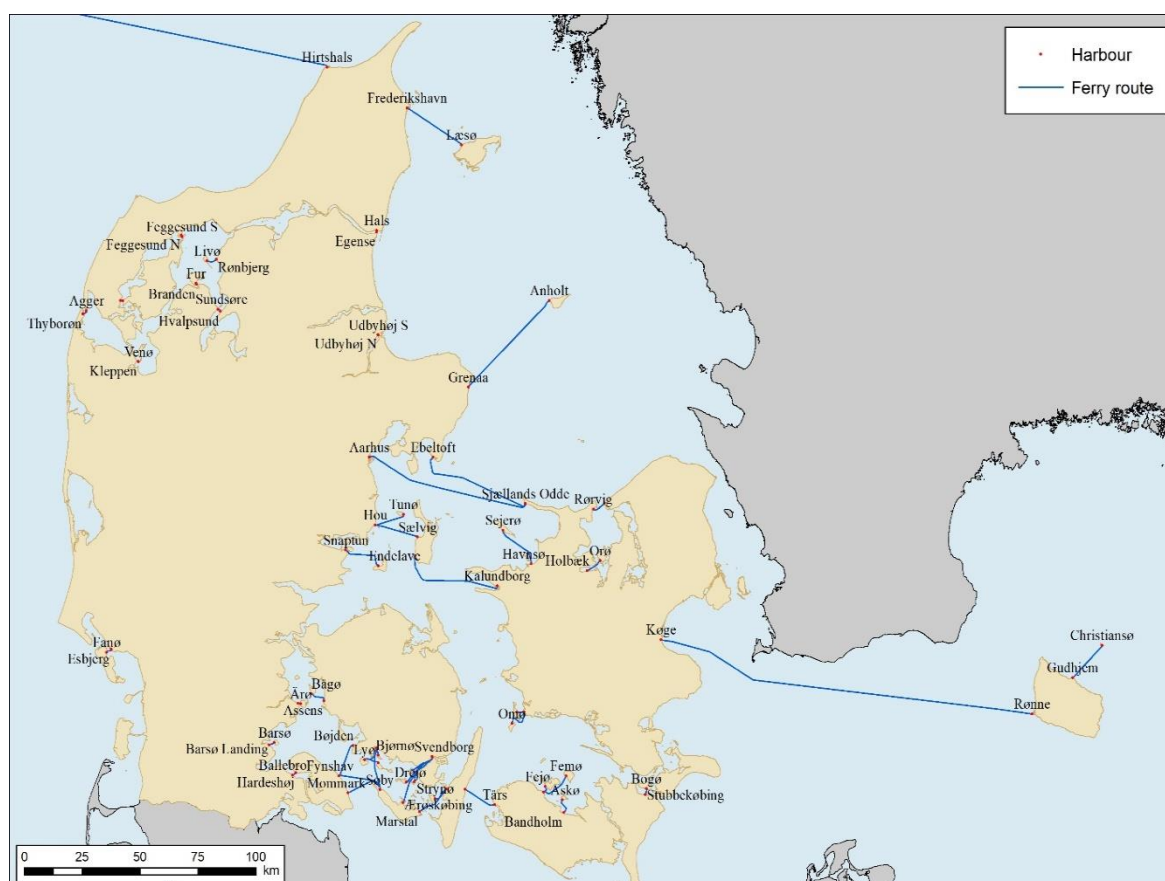

Figure 3.3.41 Ferry routes in Denmark (2020).

Table 3.3.9 lists the small ferry routes (island and short cut ferries) included in the Danish inventory for the period 1990-2020. For these ferry routes and the years 1990-2020, the following detailed traffic and technical data have been gathered by Rasmussen (2017) and Andersen (2019): Ferry name, engine size (MCR), engine year, share of annual trips and sailing time (single trip). Supplementary data for engine type, fuel type and average load factor is provided by Kristensen (2017).

Table 3.3.9 Small ferry routes comprised in the Danish inventory.

Ferry service	Service period
Assens-Baagø	1990+
Ballebro-Hardeshøj	1990+
Bandholm-Askø	1990+
Barsø Landing-Barsø	2018+
Branden-Fur	1990+
Bøjden-Fynshav	1990+
Esbjerg-Fanø	1990+
Feggesund overfart	1990+
Fejøl-Kragenæs	1990+
Femøl-Kragenæs	1990+
Frederikssund-Roskilde	1999-2000
Fåborg-Avernakøl-Lyøl	1990+
Fåborg-Søby	1990+
Grenaa-Anholt	1990+
Gudhjem-Christiansøl	2015+
Hals-Egense	1994+
Havnsøl-Sejerøl	1990+
Holbæk-Orøl	1990+
Horsens-Endelave	1990+
Hov-Tunøl	1990+
Hundested-Rørvig	1990+
Hvalpsund-Sundsøre	1990+
Kastrup-Rønne	1990
Kleppen-Venøl	1990+
Korsør-Lohals	1990+
Kragenæs-Askøl	2020+
København-Århus	1992-1993
Næssund overfart	1990+
Rudkøbing-Marstal	-2013
Rudkøbing-Strynøl	1990+
Stignæs-Agersøl	1990+
Stignæs-Omøl	1990+
Stubbekøbing-Bogøl	1990+
Svendborg-Skarøl-Drejøl	1990+
Søby-Fynshav	2009+
Søby-Mommark	-2009
Thyborøn-Agger	1990+
Udbyhøj Nord - Udbyhøj Syd	2017+
Aarøl-Aarøsund	1990+

The number of round trips per ferry route from 1990 to 2020 is provided by Statistics Denmark (2021d). Figure 3.3.41 show all ferry routes in use in 2020 (Esbjerg/Hanstholm/Hirtshals-Torshavn not shown).

For all ferry routes, detailed data in terms of ferry name, engine size (MCR), engine type, fuel type, average load factor, auxiliary engine size, number of trips and sailing time (single trip) is shown in Annex 3.B.12 for the years 1985-2020. There is a lack of historical traffic data for 1985-1989, and hence, data for 1990 are used for these years, to support the fuel consumption and emission calculations.

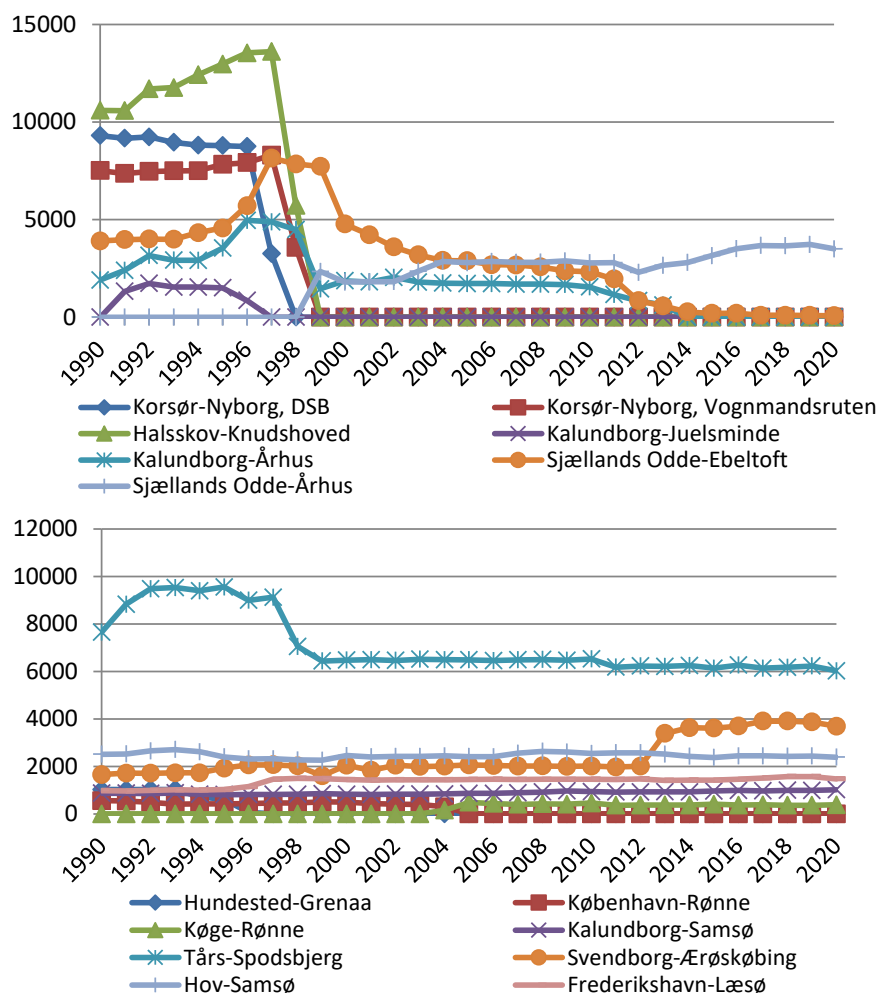

Figure 3.3.42 No. of round trips for the most important ferry routes in Denmark 1990-2020.

It is seen from Table 3.3.8 (and Figure 3.3.42) that several ferry routes were closed in the time period from 1996-1998, mainly due to the opening of the Great Belt Bridge (connecting Zealand and Funen) in 1997. Hundested-Grenaa and Kalundborg-Juelsminde was closed in 1996, Korsør-Nyborg (DSB) closed in 1997, and Halskov-Knudshoved and Korsør-Nyborg (Vognmandsruten) was closed in 1998. The ferry line København-Rønne was replaced by Køge-Rønne in 2004 and from 1999, a new ferry connection was opened between Sjællands Odde and Århus.

The fuel sold for freight transport by Royal Arctic Line between Aalborg (Denmark) and Greenland is included under other national sea transport in the Danish inventories. In this case all fuel is being bought in Denmark (Rasmussen, 2021). The fuel used by freight transport between Denmark and the Faroe Islands (Eimskip) is bought outside Denmark (Helgason, 2021). Hence, this fuel consumption is not included in the Danish inventories at all.

Fuel used for the remaining part of the traffic between two Danish ports, other national sea transport, is taken as the difference between 1) DEA national fuel sales for national sea transport minus fuel consumption at Danish off shore installations (off shore reduced fuel sales¹³) and 2) the bottom-up calculated fuel consumption for Danish ferries.

For years when the fuel estimates for ferries (not including the ferry to the Faroe Islands) are higher than the “off shore reduced” fuel sold for national sea transport, fuel is taken from fisheries in the case of marine diesel (1985-1999). For heavy fuel oil, the missing fuel amount is taken from stationary sources (1985-1986, 1988, 1994-1996) and international sea transport (2015 onwards).

The LNG fuel calculated for Danish ferries is slightly higher than the LNG fuel sales for national navigation reported in the DEA fuel statistics. Subsequently, an inventory fuel balance is made to account for the total LNG fuel sold reported in the DEA fuel statistics.

For fishing vessels the following log data are provided by the Danish Fisheries Agency for each fishing trip made by Danish registered fishing vessels from 1985-2020: Vessel registration number, build year, type, overall length (OAL), brutto tonnes (BT), total installed engine power (kW) and hours at sea. Average engine load factors (%) are taken from Winther and Martinsen (2020) based on data provided by Hanstholm Fisheries Association (Amdissen, 2020).

Figure 3.3.43 show hours at sea for the Danish fishing vessels split into OAL classes for the years 1990-2020.

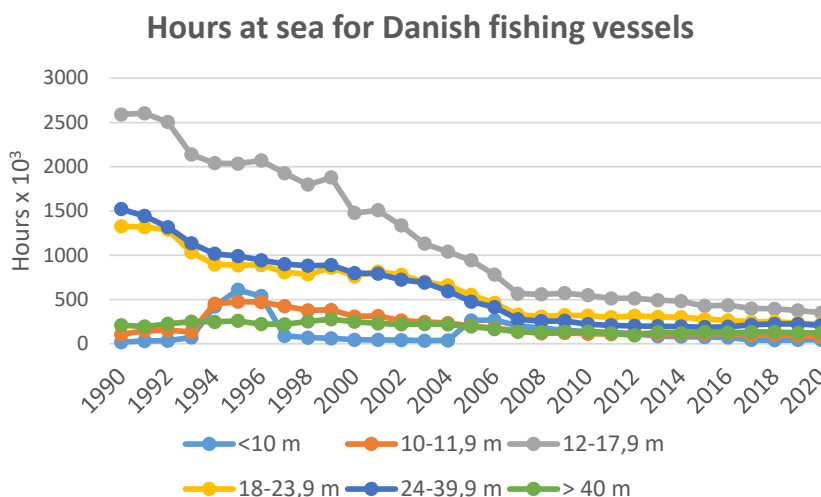

Figure 3.3.43 Total hours at sea for Danish fishing vessels 1990-2020.

For Danish fishing vessels, data for total hours at sea and engine loads (%) are shown in Annex 3.B.12 split into OAL classes for the years 1985-2020.

Other sectors

The activity data for military, railways and international sea consists of fuel consumption information from DEA (2021a).

¹³ According to the Danish Energy Authority, the latter diesel fuel sales are reported as sold for national navigation by the fuel sales reporting oil companies.

For international sea transport, the basis is in principle fuel sold in Danish ports for vessels with a foreign destination (i.e. outside the Kingdom of Denmark), as prescribed by the IPCC guidelines. However, it must be noted that fuel sold for sailing activities between Denmark and Greenland/Faroe Islands are reported as international in the DEA energy statistics. Hence, for inventory purposes in order to follow the IPCC guidelines, the fuel estimated for the ferry routes Esbjerg/Hanstholm/Hirtshals-Torshavn, and fuel bought by Royal Arctic Line is transferred from international sea transport to national sea transport in fuel sales, prior to inventory fuel input.

For years when bottom up diesel estimates for national sea transport are higher than DEA reported fuel sold for national sea transport, diesel is transferred from fisheries to national sea transport in the inventories. In addition, the bottom up diesel estimate for recreational craft is subtracted from fisheries and grouped in the "Other" inventory category together with military activities.

Summarized up per fuel type, the above described fuel transfers involving the sectors national and international sea transport, fisheries and stationary industrial sources becomes zero, thus leaving the national energy balance unchanged.

For all sectors, fuel consumption figures are given in Annex 3.B.15 for the years 1990 and 2020 in CollectER format, and fuel consumption time series are given in Annex 3.B.16 in NFR format.

Emission legislation

For other modes of transport and non-road machinery, the engines have to comply with the emission legislation limits agreed by the EU and different UN organisations in terms of NO_x, CO, VOC and TSP emissions and fuel sulphur content. In terms of greenhouse gases, the emission legislation requirements for VOC influence the emissions of CH₄, the latter emission component forming a part of total VOC. Only for ships, legislative limits for specific fuel consumption have been internationally agreed in order to reduce the emissions of CO₂.

For non-road working machinery and equipment, and recreational craft and railway locomotives/motor cars, the emission directives list specific emission limit values (g per kWh) for CO, VOC, NO_x (or VOC + NO_x) and TSP, depending on engine size (kW for diesel, ccm for gasoline) and date of implementation (referring to engine market date).

For diesel, the directives 97/68 and 2004/26 (Table 3.3.10) relate to Stage I-IV non-road machinery other than agricultural and forestry tractors and the directives have different implementation dates for machinery operating under transient and constant loads. The latter directive also comprises emission limits for Stage IIIA and IIIB railways machinery (Table 3.3.14). For Stage I-IV tractors the relevant directives are 2000/25 and 2005/13 (Table 3.3.10).

For emission approval of the EU Stage I, II and IIIA engine technologies, emissions (and fuel consumption) measurements are made using the steady state test cycle ISO 8178 C1, referred to as the Non-Road Steady Cycle (NRSC), see e.g. www.dieselnet.com. In addition to the NRSC test, the newer Stage IIIB and IV (and optionally Stage IIIA) engine technologies are tested under more

realistic operational conditions using the new Non-Road Transient Cycle (NRTC).

For gasoline, the directive 2002/88 distinguishes between Stage I and II hand-held (SH) and not hand-held (NS) types of machinery (Table 3.3.11). Emissions are tested using one of the specific constant load ISO 8178 test cycles (D2, G1, G2, G3) depending on the type of machinery.

For Stage V machinery, EU directive 2016/1628 relate to non-road machinery other than agricultural tractors and railways machinery (Table 3.3.10) and non-road gasoline machinery (Table 3.3.11). EU directive 167/2013 relate to Stage V agricultural and forestry tractors (Table 3.3.10). The Stage V emission limits are also shown in Annex 3.B.11.

Table 3.3.10 Overview of EU emission directives relevant for diesel fuelled non-road machinery.

Stage	Engine size [kW]	CO [g/kWh]	VOC	NO _x	VOC+NO _x PM	Diesel machinery			Tractors		
						EU Directive	Implement. date Transient	Constant	EU Directive	Implement. Date	
Stage I											
A	130≤P<560	5	1.3	9.2	-	0.54	97/68	1/1 1999	-	2000/25	1/7 2001
B	75≤P<130	5	1.3	9.2	-	0.7		1/1 1999	-		1/7 2001
C	37≤P<75	6.5	1.3	9.2	-	0.85		1/4 1999	-		1/7 2001
Stage II											
E	130≤P<560	3.5	1	6	-	0.2	97/68	1/1 2002	1/1 2007	2000/25	1/7 2002
F	75≤P<130	5	1	6	-	0.3		1/1 2003	1/1 2007		1/7 2003
G	37≤P<75	5	1.3	7	-	0.4		1/1 2004	1/1 2007		1/1 2004
D	18≤P<37	5.5	1.5	8	-	0.8		1/1 2001	1/1 2007		1/1 2002
Stage IIIA											
H	130≤P<560	3.5	-	-	4	0.2	2004/26	1/1 2006	1/1 2011	2005/13	1/1 2006
I	75≤P<130	5	-	-	4	0.3		1/1 2007	1/1 2011		1/1 2007
J	37≤P<75	5	-	-	4.7	0.4		1/1 2008	1/1 2012		1/1 2008
K	19≤P<37	5.5	-	-	7.5	0.6		1/1 2007	1/1 2011		1/1 2007
Stage IIIB											
L	130≤P<560	3.5	0.19	2	-	0.025	2004/26	1/1 2011	-	2005/13	1/1 2011
M	75≤P<130	5	0.19	3.3	-	0.025		1/1 2012	-		1/1 2012
N	56≤P<75	5	0.19	3.3	-	0.025		1/1 2012	-		1/1 2012
P	37≤P<56	5	-	-	4.7	0.025		1/1 2013	-		1/1 2013
Stage IV											
Q	130≤P<560	3.5	0.19	0.4	-	0.025	2004/26	1/1 2014	1/1 2014	2005/13	1/1 2014
R	56≤P<130	5	0.19	0.4	-	0.025		1/10 2014	1/10 2014		1/10 2014
Stage V ^A											
NRE-v/c-7	P>560	3.5	0.19	3.5		0.045	2016/1628		2019	167/2013 ^B	2019
NRE-v/c-6	130≤P≤560	3.5	0.19	0.4		0.015			2019		2019
NRE-v/c-5	56≤P<130	5.0	0.19	0.4		0.015			2020		2020
NRE-v/c-4	37≤P<56	5.0			4.7	0.015			2019		2019
NRE-v/c-3	19≤P<37	5.0			4.7	0.015			2019		2019
NRE-v/c-2	8≤P<19	6.6			7.5	0.4			2019		2019
NRE-v/c-1	P<8	8.0			7.5	0.4			2019		2019
Generators	P>560	0.67	0.19	3.5		0.035			2019		2019

A = For selected machinery types, Stage V includes emission limit values for particle number.

B = Article 63 in 2016/1628 revise Article 19 in 167/2013 to include Stage V limits as described in 2016/1628.

Table 3.3.11 Overview of the EU Emission Directives relevant for gasoline fuelled non-road machinery.

	Category	Engine size [ccm]	CO	HC	NO _x	HC+NO _x	Implement. date
			[g pr kWh]	[g pr kWh]	[g pr kWh]	[g pr kWh]	
EU Directive 2002/88		Stage I					
Hand held	SH1	S<20	805	295	5.36	-	1/2 2005
	SH2	20≤S<50	805	241	5.36	-	1/2 2005
	SH3	50≤S	603	161	5.36	-	1/2 2005
Not hand held	SN3	100≤S<225	519	-	-	16.1	1/2 2005
	SN4	225≤S	519	-	-	13.4	1/2 2005
		Stage II					
Hand held	SH1	S<20	805	-	-	50	1/2 2008
	SH2	20≤S<50	805	-	-	50	1/2 2008
	SH3	50≤S	603	-	-	72	1/2 2009
Not hand held	SN1	S<66	610	-	-	50	1/2 2005
	SN2	66≤S<100	610	-	-	40	1/2 2005
	SN3	100≤S<225	610	-	-	16.1	1/2 2008
	SN4	225≤S	610	-	-	12.1	1/2 2007
EU Directive 2016/1628		Stage V					
Hand held (<19 kW)	NRSh-v-1a	S<50	805	-	-	50	2019
	NRSh-v-1b	50≤S	805	-	-	72	2019
Not hand held (P<19 kW)	NRS-vr/vi-1a	80≤S<225	610	-	-	10	2019
	NRS-vr/vi-1b	S≥225	610	-	-	8	2019
Not hand held (19=<P<30 kW)	NRS-v-2a	S≤1000	610	-	-	8	2019
	NRS-v-2b	S>1000	4.40*	-	-	2.70*	2019
Not hand held (30=<P<56 kW)	NRS-v-3	any	4.40*	-	-	2.70*	2019

* Or any combination of values satisfying the equation $(HC+NO_x) \times CO^{0.784} \leq 8.57$ and the conditions $CO \leq 20.6$ g/kWh and $(HC+NO_x) \leq 2.7$ g/kWh.

For recreational craft, Directive 2003/44 comprises the Stage 1 emission legislation limits for diesel engines, and for 2-stroke and 4-stroke gasoline engines, respectively. The CO and VOC emission limits depend on engine size (kW) and the inserted parameters presented in the calculation formulas in Table 3.3.12. For NO_x, a constant limit value is given for each of the three engine types. For TSP, the constant emission limit regards diesel engines only.

In Table 3.3.13, the Stage II emission limits are shown for recreational craft. CO and HC+NO_x limits are provided for gasoline engines depending on the rated engine power and the engine type (stern-drive vs. outboard) while CO, HC+NO_x, and particulate emission limits are defined for compression ignition (CI) engines depending on the rated engine power and the swept volume.

Table 3.3.12 Overview of the EU Emission Directive 2003/44 for recreational craft.

Engine type	Impl. date	CO=A+B/P ⁿ			HC=A+B/P ⁿ			NO _x	TSP
		A	B	n	A	B	n		
2-stroke gasoline	1/1 2007	150.0	600.0	1.0	30.0	100.0	0.75	10.0	-
4-stroke gasoline	1/1 2006	150.0	600.0	1.0	6.0	50.0	0.75	15.0	-
Diesel	1/1 2006	5.0	0.0	0	1.5	2.0	0.5	9.8	1.0

Table 3.3.13 Overview of the EU Emission Directive 2013/53 for recreational craft.

Diesel engines					
Swept Volume, SV l/cyl.	Rated Engine Power, P _N kW	Impl. Date	CO g/kWh	HC + NO _x g/kWh	PM g/kWh
SV < 0.9	P _N < 37				
	37 ≤ P _N < 75 (*)	18/1 2017	5	4.7	0.30
	75 ≤ P _N < 3 700	18/1 2017	5	5.8	0.15
0.9 ≤ SV < 1.2	P _N < 3 700	18/1 2017	5	5.8	0.14
1.2 ≤ SV < 2.5		18/1 2017	5	5.8	0.12
2.5 ≤ SV < 3.5		18/1 2017	5	5.8	0.12
3.5 ≤ SV < 7.0		18/1 2017	5	5.8	0.11
Gasoline engines					
Engine type	Rated Engine Power, P _N kW		CO g/kWh	HC + NO _x g/kWh	PM g/kWh
Stern-drive and inboard engines	P _N ≤ 373	18/1 2017	75	5	-
	373 ≤ P _N ≤ 485	18/1 2017	350	16	-
	P _N > 485	18/1 2017	350	22	-
Outboard engines and PWC engines (**)	P _N ≤ 4.3	18/1 2017	500 – (5.0 × P _N)	15.7 + (50/P _N ^{0.9})	-
	4.3 ≤ P _N ≤ 40	18/1 2017	500 – (5.0 × P _N)	15.7 + (50/P _N ^{0.9})	-
	P _N > 40	18/1 2017	300		-

(*) Alternatively, this engine segment shall not exceed a PM limit of 0.2 g/kWh and a combined HC + NO_x limit of 5.8 g/kWh.
(**) Small and medium size manufacturers making outboard engines ≤ 15 kW have until 18/1 2020 to comply.

Table 3.3.14 Overview of the EU Emission Directives relevant for railway locomotives and motorcars.

			CO	HC	NO _x	HC+NO _x	PM		
EU directive			g/kWh					Imp. date	
Locomotives	2004/26	Stage IIIA							
		130 ≤ P < 560	RL A	3.5	-	-	4	0.2	1/1 2007
		560 < P	RH A	3.5	0.5	6	-	0.2	1/1 2009
	2000 ≤ P and piston displacement ≥ 5 l/cyl.	RH A	3.5	0.4	7.4	-	0.2	1/1 2009	
	2004/26	Stage IIIB	RB	3.5	-	-	4	0.025	1/1 2012
2016/1628	Stage V								
	0 < P	RLL-v/c-1	3.5	-	-	4	0.025	2021	
Motor cars	2004/26	Stage IIIA							
		130 < P	RC A	3.5	-	-	4	0.2	1/1 2006
	2004/26	Stage IIIB							
		130 < P	RC B	3.5	0.19	2	-	0.025	1/1 2012
	2016/1628	Stage V							
	0 < P	RLR-v/c-1	3.5	0.19	2	-	0.015	2021	

Aircraft engine emissions of NO_x, CO, VOC and smoke are regulated by ICAO (International Civil Aviation Organization). The engine emission certification standards are contained in Annex 16 – Environmental Protection, Volume II – to the Convention on International Civil Aviation (ICAO Annex 16, 2008, plus amendments). The emission standards relate to the total emissions (in grams) from the so-called LTO (Landing and Take Off) cycle divided by the rated engine thrust (kN). The ICAO LTO cycle contains the idealised aircraft movements below 3000 ft (915 m) during approach, landing, airport taxiing, take off and climb out.

For smoke, all aircraft engines manufactured from 1 January 1983 have to meet the emission limits agreed by ICAO. For NO_x, CO, VOC The emission

legislation is relevant for aircraft engines with a rated engine thrust larger than 26.7 kN. In the case of CO and VOC, the ICAO regulations apply for engines manufactured from 1 January 1983.

For NO_x , the emission regulations fall in five categories

- For engines of a type or model for which the date of manufacture of the first individual production model was before 1 January 1996, and for which the production date of the individual engine was before 1 January 2000.
- For engines of a type or model for which the date of manufacture of the first individual production model is on or after 1 January 1996, or for individual engines with a production date on or after 1 January 2000.
- For engines of a type or model for which the date of manufacture of the first individual production model is on or after 1 January 2004.
- For engines of a type or model for which the date of manufacture of the first individual production model is on or after 1 January 2008, or for individual engines with a production date on or after 1 January 2013.
- For engines of a type or model for which the date of manufacture of the first individual production model is on or after 1 January 2014.

The regulations published by ICAO are given in the form of the total quantity of pollutants (D_p) emitted in the LTO cycle divided by the maximum sea level thrust (F_{oo}) and plotted against engine pressure ratio at maximum sea level thrust.

The limit values for NO_x are given by the formulae in Table 3.3.15.

Table 3.3.15 Current certification limits for NO_x for turbo jet and turbo fan engines.

	Engines first produced before 1.1.1996 & for engines manufactured before 1.1.2000	Engines first produced on or after 1.1.1996 & for engines manufactured on or after 1.1.2000	Engines for which the date of manufacture of the first individual production model was on or after 1 January 2004	Engines first produced on or after 1.1.2047 & for engines manufactured on or after 1.1.2013	Engines for which the date of manufacture of the first individual production model was on or after 1.1.2014
Applies to engines >26.7 kN	$D_p/F_{oo} = 40 + 2\pi_{oo}$	$D_p/F_{oo} = 32 + 1.6\pi_{oo}$			
Engines of pressure ratio less than 30					
Thrust more than 89 kN			$D_p/F_{oo} = 19 + 1.6\pi_{oo}$	$D_p/F_{oo} = 16.72 + 1.4080\pi_{oo}$	$7.88 + 1.4080\pi_{oo}$
Thrust between 26.7 kN and not more than 89 kN			$D_p/F_{oo} = 37.572 + 1.6\pi_{oo} - 0.208F_{oo}$	$D_p/F_{oo} = 38.54862 + (1.6823\pi_{oo}) - (0.2453F_{oo}) - (0.00308\pi_{oo}F_{oo})$	$D_p/F_{oo} = 40.052 + 1.5681\pi_{oo} - 0.3615F_{oo} - 0.0018\pi_{oo} \times F_{oo}$
Engines of pressure ratio more than 30 and less than 62.5 (104.7)					
Thrust more than 89 kN			$D_p/F_{oo} = 7 + 2.0\pi_{oo}$	$D_p/F_{oo} = -1.04 + (2.0^* \pi_{oo})$	
Thrust between 26.7 kN and not more than 89 kN			$D_p/F_{oo} = 42.71 + 1.4286\pi_{oo} - 0.4013F_{oo} + 0.00642\pi_{oo}F_{oo}$	$D_p/F_{oo} = 46.1600 + (1.4286\pi_{oo}) - (0.5303F_{oo}) - (0.00642\pi_{oo}F_{oo})$	
Engines with pressure ratio 62.5 or more					
Engines with pressure ratio 82.6 or more			$D_p/F_{oo} = 32 + 1.6\pi_{oo}$	$D_p/F_{oo} = 32 + 1.6\pi_{oo}$	
Engines of pressure ratio more than 30 and less than (104.7)					
Thrust more than 89 kN					$D_p/F_{oo} = -9.88 + 2.0\pi_{oo}$
Thrust between 26.7 kN and not more than 89 kN					$D_p/F_{oo} = 41.9435 + 1.505\pi_{oo} - 0.5823F_{oo} + 0.005562\pi_{oo} \times F_{oo}$
Engines with pressure ratio 104.7 or more					
					$D_p/F_{oo} = 32 + 1.6\pi_{oo}$

Source: International Standards and Recommended Practices, Environmental Protection, ICAO Annex 16 Volume II 3rd edition July 2008, plus amendments: Amendment 7 (17 November 2011), Amendment 8 (July 2014),

where:

D_p = the sum of emissions in the LTO cycle in g.

F_{oo} = thrust at sea level take-off (100 %).

π_{oo} = pressure ratio at sea level take-off thrust point (100 %).

The equivalent limits for HC and CO are $D_p/F_{oo} = 19.6$ for HC and $D_p/F_{oo} = 118$ for CO (ICAO Annex 16 Vol. II paragraph 2.2.2). Smoke is limited to a regulatory smoke number = $83 (F_{oo})^{-0.274}$ or a value of 50, whichever is the lower.

A further description of the technical definitions in relation to engine certification as well as actual engine exhaust emission measurement data can be found in the ICAO Engine Exhaust Emission Database. The latter database is accessible from “www.easa.europa.eu/domains/environment/icao-aircraft-engine-emissions-databank” hosted by the European Aviation Safety Agency (EASA).

On 8 February 2016, at the tenth meeting of the International Civil Aviation Organization (ICAO) Committee for Environmental Protection (CAEP) a performance standard was agreed for new aircraft that will mandate improvements in fuel efficiency and reductions in carbon dioxide (CO₂) emissions. The standards will on average require a 4 % reduction in the cruise fuel consumption of new aircraft starting in 2028 compared to 2015 deliveries, with the actual reductions ranging from 0 to 11 %, depending on the maximum takeoff mass (MTOM) of the aircraft (ICCT, 2017).

The CO₂ certification standards are contained in a new Volume III - CO₂ Certification Requirement - to Annex 16 of the Convention on civil aviation (ICAO, 2017).

Embedded applicability dates are:

- **Subsonic jet aeroplanes**, including their derived versions, of greater than 5 700 kg maximum take-off mass for which the application for a type certificate was submitted on or after 1 January 2020, except for those aeroplanes of less than or equal to 60 000 kg maximum take-off mass with a maximum passenger seating capacity of 19 seats or less;
- **Subsonic jet aeroplanes**, including their derived versions, of greater than 5 700 kg and less than or equal to 60 000 kg maximum take-off mass with a maximum passenger seating capacity of 19 seats or less, for which the application for a type certificate was submitted on or after 1 January 2023;
- **All propeller-driven aeroplanes**, including their derived versions, of greater than 8 618 kg maximum take-off mass, for which the application for a type certificate was submitted on or after 1 January 2020;
- **Derived versions of non-CO₂-certified subsonic jet aeroplanes** of greater than 5 700 kg maximum certificated take-off mass for which the application for certification of the change in type design was submitted on or after 1 January 2023;
- **Derived versions of non-CO₂ certified propeller-driven aeroplanes** of greater than 8 618 kg maximum certificated take-off mass for which the application for certification of the change in type design was submitted on or after 1 January 2023;
- **Individual non-CO₂-certified subsonic jet aeroplanes** of greater than 5 700 kg maximum certificated take-off mass for which a certificate of airworthiness was first issued on or after 1 January 2028; and
- **Individual non-CO₂-certified propeller-driven aeroplanes** of greater than 8 618 kg maximum certificated take-off mass for which a certificate of airworthiness was first issued on or after 1 January 2028.

Marpol 73/78 Annex VI agreed by IMO (International Maritime Organisation) concerns the control of NO_x emissions (Regulation 13 plus amendments) and SO_x and particulate emissions (Regulation 14 plus amendments) from ships (DNV, 2009). Recently the so called Energy Efficiency Design Index (EEDI) fuel efficiency regulations for new built ships was included in Chapter 4 of Annex VI in the Marpol convention for the purpose of controlling the CO₂ emissions from ships (Lloyd's Register, 2012).

The baseline NO_x emission regulation of Annex VI apply for diesel engines with a power output higher than 130 kW, which are installed on a ship constructed on or after 1 January 2000 and diesel engines with a power output higher than 130 kW which undergo major conversion on or after 1 January 2000.

The baseline NO_x emission limits for ship engines in relation to their rated engine speed (n) given in RPM (Revolutions Per Minute) are the following:

- 17 g pr kWh, n < 130 RPM
- 45 x n-0.2 g pr kWh, 130 ≤ n < 2000 RPM
- 9.8 g pr kWh, n ≥ 2000 RPM

The further amendment of Annex VI Regulation 13 contains a three tiered approach in order to strengthen the emission standards for NO_x. The three tier approach comprises the following:

- Tier I: Diesel engines (> 130 kW) installed on a ship constructed on or after 1 January 2000 and prior to 1 January 2011 (initial regulation).
- Tier II: Diesel engines (> 130 kW) installed on a ship constructed on or after 1 January 2011.
- Tier III¹⁴: Diesel engines (> 130 kW) installed on a ship constructed on or after 1 January 2016 operating in the North American ECA or the United States Caribbean Sea ECA and diesel engines (> 130 kW) installed on a ship constructed on or after 1 January 2021 operating in the Baltic Sea and North Sea ECA.

The three tier NO_x emission limit functions are shown in Table 3.3.16.

Table 3.3.16 Tier I-III NO_x emission limits for ship engines in MARPOL Annex VI.

	NO _x limit	RPM (n)
Tier I	17 g pr kWh	n < 130
	45 · n-0.2 g pr kWh	130 ≤ n < 2000
	9,8 g pr kWh	n ≥ 2000
Tier II	14.4 g pr kWh	n < 130
	44 · n-0.23 g pr kWh	130 ≤ n < 2000
	7.7 g pr kWh	n ≥ 2000
Tier III	3.4 g pr kWh	n < 130
	9 · n-0.2 g pr kWh	130 ≤ n < 2000
	2 g pr kWh	n ≥ 2000

Further, the NO_x Tier I limits are to be applied for existing engines with a power output higher than 5000 kW and a displacement per cylinder at or above 90 litres, installed on a ship constructed on or after 1 January 1990 but prior to 1 January 2000.

In relation to the sulphur content in heavy fuel and marine gas oil used by ship engines, Table 3.3.17 shows the EU and IMO (Regulation 14 plus amendments) legislation in force for SECA (Sulphur Emission Control Area) areas and outside SECA's.

Table 3.3.17 Current legislation in relation to marine fuel quality.

Legislation	Marine area	Heavy fuel oil		Gas oil	
		S- %	Implement. date	S- %	Implement. date
EU-directive 93/12		None		0.2 ¹	01.10.1994
EU-directive 1999/32		None		0.2	01.01.2000
EU-directive 2005/33 ²	SECA - Baltic sea	1.5	11.08.2006	0.1	01.01.2008
	SECA - North sea	1.5	11.08.2007	0.1	01.01.2008
	Outside SECA's	None		0.1	01.01.2008
MARPOL Annex VI	SECA – Baltic sea	1.5	19.05.2006		
	SECA – North sea	1.5	21.11.2007		
	Outside SECA	4.5	19.05.2006		
MARPOL Annex VI amendments	SECA's	1	01.03.2010		
	SECA's	0.1	01.01.2015		
	Outside SECA's	3.5	01.01.2012		
	Outside SECA's	0.5	01.01.2020		

¹ Sulphur content limit for fuel sold inside EU.

² From 1.1.2010 fuel with a sulphur content higher than 0.1 % must not be used in EU ports for ships at berth exceeding two hours.

¹⁴ For ships operating in a designated Emission Control Area. Outside a designated Emission Control Area, Tier II limits apply.

In Marpol 83/78 Annex VI (Chapter 4), the EEDI fuel efficiency regulations are mandatory from 1st January 2013 for new built ships larger than 400 GT.

EEDI is a design index value that expresses how much CO₂ is produced per work done (g CO₂ per tonnes.nm¹⁵). At present, the IMO EEDI scheme comprises the following ship types; bulk carriers, gas carriers, tankers, container ships, general cargo ships, refrigerated and combination cargo carriers.

The EEDI percentage reductions that need to be achieved for new built ships relative to existing ships, are shown in Table 5.11 stratified according to ship type and dead weight tonnes (DWT) in the temporal phases (new built year in brackets); 0 (2013-14), 1 (2015-19), 2 (2020-24) and 3 (2025+).

Table 3.3.18 EEDI percentage reductions for new built ships relative to existing ships.

Ship type	Size	Phase 0	Phase 1	Phase 2	Phase 3
		1-Jan-2013 to 31-Dec-2014	1-Jan-2015 to 31-Dec-2019	1-Jan-2020 to 31-Dec-2024	1-Jan-2025 onwards
Bulk carrier	20,000 DWT and above	0	10	20	30
	10,000 – 20,000 DWT	n/a	0-10*	0-20*	0-30*
Gas carrier	10,000 DWT and above	0	10	20	30
	2,000 – 10,000 DWT	n/a	0-10*	0-20*	0-30*
Tanker	20,000 DWT and above	0	10	20	30
	4,000 – 20,000 DWT	n/a	0-10*	0-20*	0-30*
Container ship	15,000 DWT and above	0	10	20	30
	10,000 – 15,000 DWT	n/a	0-10*	0-20*	0-30*
General cargo ship	15,000 DWT and above	0	10	15	30
	3,000 – 15,000 DWT	n/a	0-10*	0-15*	0-30*
Refrigerated cargo carrier	5,000 DWT and above	0	10	15	30
	3,000 – 5,000 DWT	n/a	0-10*	0-15*	0-30*
Combination carrier	20,000 DWT and above	0	10	20	30
	4,000 – 20,000 DWT	n/a	0-10*	0-20*	0-30*

It is envisaged that also Ro-ro cargo, ro-ro passenger and cruise passenger ships will be included in the EEDI scheme in the near future.

For non-road machinery, the EU directive 2003/17/EC gives a limit value of 10 ppm sulphur in diesel (from 2011).

Emission factors

The CO₂ emission factors for other fuels than LNG, LPG and diesel are country-specific and come from Fenhann and Kilde (1994). For LNG, the CO₂ emission factor is estimated by the Danish gas transmission company, Energinet.dk, based on gas analysis data. For LPG, the emission factor source is EMEP/EEA (2019) and for diesel the emission factor is taken from IPCC (2006).

The N₂O emission factors are taken from the EMEP/EEA guidebook; EMEP/EEA (2019) for road transport and non-road machinery, and IPCC (2006) for national sea transport and fisheries as well as aviation.

In the case of military ground equipment, due to lack of fleet/activity and emission data, aggregated CH₄ emission factors for gasoline and diesel are derived from total road traffic emission results. For piston engine aircraft using aviation gasoline, the CH₄ emission factors are derived from VOC factors from EMEP/EEA (2019) and a NMVOC/CH₄ split, based on expert judgement.

¹⁵ nm: nautical mile.

The CH₄ emission factors for railways are derived from specific Danish VOC measurements from the Danish State Railways (Mølgård, 2021) and a NMVOC/CH₄ split, based on expert judgement.

For agriculture, forestry, industry, household gardening and recreational craft, the VOC emission factors are derived from various European measurement programmes; see IFEU (2004, 2009), Notter and Schmied (2015) and Winther et al. (2006). The NMVOC/CH₄ split is taken from IFEU (2009).

For national sea transport and fisheries, the VOC emission factors come from Danish TEMA2015 emission model (Ministry of Transport, 2015). Specifically for the ferries used by Mols Linjen, VOC emission factors are provided by Kristensen (2008), originating from engine measurements (Hansen et al., 2004; Wismann, 1999; PHP, 1996). Complimentary VOC emission factor data for new ferries is provided by Kristensen (2013) and engine load specific VOC emission data is provided by Nielsen (2019).

For the LNG fuelled ferry in service on the Hou-Sælvig route, CH₄ and NMVOC emission factors are taken from Bengtsson et al. (2011).

For marine engines using diesel or residual oil, VOC/CH₄ splits are taken from EMEP/EEA (2019).

For national sea transport, international sea transport and fisheries, total fuel consumption and aggregated emission factors per fuel type are shown Annex 3.B.13 for the years 1985-2020. For ferries, total fuel consumption and emission factors per ferry per route are shown Annex 3.B.13 for 2020. For fisheries total engine MWh's produced, total fuel consumption, fuel balance factors and emission factors are shown Annex 3.B.13 for 1985-2020.

The source for aviation (jet fuel) CH₄ emission factors is the EMEP/EEA guidebook (EMEP/EEA, 2019). For a number of different representative aircraft types, the EMEP/EEA guidebook comprises fuel flow and NO_x, CO and VOC emission indices for the four LTO modes and distance based emission factors for cruise. For auxiliary power units (APU), ICAO (2011) is the data source for APU load specific NO_x, CO and VOC emission factors for different APU aircraft groups to be linked with the different representative aircraft types. VOC/CH₄ splits for aviation are taken from EMEP/EEA (2019).

Annex 3.B.14 list the lower heating values (LHV) for the inventory fuel types together with their references. The LHV's are used to transform emission factors from g/kg fuel into g/MJ or fuel results from kg into MJ if needed in the inventories.

For all sectors, emission factors for the years 1990 and 2020 are given in CollectER format in Annex 3.B.15.

Table 3.3.19 shows the aggregated emission factors for CO₂, CH₄ and N₂O in 2020 used to calculate the emissions from other mobile sources in Denmark.

Table 3.3.19 The aggregated emission factors for CO₂, CH₄ and N₂O in 2020 used to calculate the emissions from other mobile sources in Denmark.

SNAP ID	Category	Fuel type	Tier level	Emission factors ¹⁶			
				CH ₄ % of VOC	CH ₄ g pr GJ	CO ₂ g pr GJ	N ₂ O g pr GJ
080100	Military	Diesel	Tier 1	10.0	0.32	74.10	3.49
080100	Military	Gasoline	Tier 1	5.0	5.29	73.00	0.64
080100	Military	Jet fuel	Tier 1	9.6	2.65	72.00	2.30
080200	Railways	Diesel	Tier 1	3.7	1.06	74.10	2.24
080300	Recreational craft	Bio ethanol	Tier 3	2.8	11.56	0.00	1.61
080300	Recreational craft	Diesel	Tier 3	2.4	2.44	74.10	2.97
080300	Recreational craft	Gasoline	Tier 3	2.8	11.56	73.00	1.61
080402	National sea traffic	Diesel	Tier 3	3.0	1.81	74.10	1.87
080402	National sea traffic	LNG	Tier 3	74.0	263.14	56.80	3.96
080402	National sea traffic	Residual oil	Tier 3	3.0	2.02	78.00	1.95
080403	Fishing	Diesel	Tier 3	3.0	1.66	74.10	1.82
080404	International sea traffic	Diesel	Tier 1	3.0	1.88	74.10	1.87
080404	International sea traffic	Residual oil	Tier 1	3.0	2.07	78.00	1.96
080501	Air traffic, Dom. < 3000 ft.	AvGas	Tier 1	2.0	8.62	73.00	2.00
080501	Air traffic, Dom. < 3000 ft.	Jet fuel	Tier 3	10.0	1.76	72.00	10.32
080502	Air traffic, Int. < 3000 ft.	Jet fuel	Tier 3	10.0	2.52	72.00	5.09
080503	Air traffic, Dom. > 3000 ft.	Jet fuel	Tier 3	0.0	0.00	72.00	2.30
080504	Air traffic, Int. > 3000 ft.	Jet fuel	Tier 3	0.0	0.00	72.00	2.30
080600	Agriculture	Bio ethanol	Tier 3	10.3	112.83	0.00	1.55
080600	Agriculture	Diesel	Tier 3	2.4	0.96	74.10	3.54
080600	Agriculture	Gasoline	Tier 3	10.3	112.83	73.00	1.55
080700	Forestry	Bio ethanol	Tier 3	6.0	240.84	0.00	0.46
080700	Forestry	Diesel	Tier 3	2.4	0.36	74.10	3.72
080700	Forestry	Gasoline	Tier 3	6.0	240.84	73.00	0.46
080800	Industry	Bio ethanol	Tier 3	3.7	57.79	0.00	1.49
080800	Industry	Diesel	Tier 3	2.4	0.82	74.10	3.49
080800	Industry	Gasoline	Tier 3	3.7	57.79	73.00	1.49
080800	Industry	LPG	Tier 3	5.0	1.75	63.10	3.50
080900	Household and gardening	Bio ethanol	Tier 3	1.9	51.67	0.00	1.16
080900	Household and gardening	Gasoline	Tier 3	1.9	51.67	73.00	1.16
081100	Commercial and institutional	Bio ethanol	Tier 3	4.0	35.44	0.00	1.31
081100	Commercial and institutional	Diesel	Tier 3	2.4	0.90	74.10	3.46
081100	Commercial and institutional	Gasoline	Tier 3	4.0	35.44	73.00	1.31
081100	Commercial and institutional	LPG	Tier 3	5.0	1.75	63.10	3.50
080501	Air traffic, Dom. < 3000 ft.	AvGas	Tier 1	2.0	8.62	73.00	2.00
080501	Air traffic, Dom. < 3000 ft.	Jet fuel	Tier 3	10.0	1.26	72.00	5.89
080502	Air traffic, Int. < 3000 ft.	Jet fuel	Tier 3	10.0	2.10	72.00	3.06
080503	Air traffic, Dom. > 3000 ft.	Jet fuel	Tier 3	0.0	0.00	72.00	2.30
080504	Air traffic, Int. > 3000 ft.	Jet fuel	Tier 3	0.0	0.00	72.00	2.30

Factors for deterioration, transient loads and gasoline evaporation for non-road machinery

The emission effects of engine wear are taken into account for diesel and gasoline engines by using the so-called deterioration factors. For diesel engines alone, transient factors are used in the calculations, to account for the emission

¹⁶ References. CO₂: Country-specific, Energinet.dk (LNG), EMEP/EEA (LPG), IPCC (diesel). N₂O: EMEP/EEA. CH₄: Railways: Danish State Railways, DCE; Agriculture/Forestry/Industry/Household-Gardening: IFEU (2004, 2009, 2014), Notter and Schmied (2015); National sea traffic/Fishing/International sea traffic: Ministry of Transport (2015), specific data from Mols Linjen, Bengtsson et al. (2011), EMEP/EEA; domestic and international aviation: EMEP/EEA.

changes caused by varying engine loads. The evaporative emissions of NMVOC are estimated for gasoline fuelling and tank evaporation. The factors for deterioration, transient loads and gasoline evaporation are taken from IFEU (2004, 2009, 2014), and are shown in Annex 3.B.10. For more details regarding the use of these factors, please refer to paragraph 3.3.4 or Winther et al. (2006).

Engine load adjustment factors for marine engines

For marine engines, specific fuel consumption (sfc) and emission factors are found to vary with engine load, and hence engine load adjustment factors, LAF, are used in the fleet activity calculations for ferries and fishing vessels to account for these engine load changes. For sfc and NO_x, N₂O, CO, VOC and PM, engine load adjustment functions are provided by IMO (2015) based on Starcrest (2013). Only sfc is adjusted in the calculations, due to the actual engine load levels for ferries and fishing vessels in the Danish inventories. The load adjustment factors are shown in Annex 3.B.12.

For a few ferries operated by Mols Linjen actual engine loads and engine load specific emission data provided by Nielsen (2019) is used to calculate precise sfc and emission factors of NO_x, CO and VOC.

3.3.4 Calculation method

Air traffic

For aviation, the domestic and international estimates are made separately for landing and takeoff (LTOs < 3000 ft), and cruising (> 3000 ft).

By using the LTO mode specific fuel flow and emission indices from EMEP/EEA (2019), the fuel consumption and emission factors for the full LTO cycle are estimated for each of the representative aircraft types used in the Danish inventory.

The fuel consumption for one LTO cycle is calculated according to the following sum formula:

$$FC_{LTO}^a = \sum_{m=1}^5 t_m \cdot ff_{a,m} \quad (15)$$

Where FC = fuel consumption (kg), m = LTO mode (approach/landing, taxi in, taxi out, take off, climb out), t = times in mode (s), ff = fuel flow (kg per s), a = representative aircraft type.

The emissions for one LTO cycle are estimated as follows:

$$E_{LTO}^a = \sum_{m=1}^5 FC_{a,m} \cdot EI_{a,m} \quad (16)$$

Where EI = emission index (g per kg fuel). Due to lack of specific airport data for approach/descent, take off and climb out, standardised times-in-modes of 4, 0.7 and 2.2 minutes are used as defined by ICAO (ICAO, 1995). For taxi in and taxi out, specific times-in-modes data are provided by Eurocontrol for the

airports present in the Danish inventory. The taxi times-in-modes data are shown in Annex 3.B.10 for the years 2001-2020.

The fuel consumption and emissions for aircraft auxiliary power units (APU's) are calculated with the same method used to estimate LTO fuel consumption and emissions for aircraft main engines (formulas 15 and 16). ICAO (2011) is the data source for APU load specific fuel flows (kg per s) and emission rates (g per kg fuel) for different APU aircraft groups (characterised by seating capacity and age). APU times-in-modes for arrival, start-up, boarding and main engine start are also provided by ICAO (2011), whereas push back time intervals are taken from an emission study made in Copenhagen Airport (Ellermann et al., 2011; Winther et al., 2015).

For each representative aircraft type, the calculated fuel consumption and emission factors per LTO are shown in Annex 3.B.10 for Copenhagen Airport and other airports (aggregated) for 2020. APU data for fuel flows, emission rates and times-in-modes are also shown in Annex 3.B.10, together with the correspondence table for APU group-representative aircraft type.

The calculations for cruise use the distance specific fuel consumption and emissions given by EMEP/EEA (2019) per representative aircraft type. Data interpolations or extrapolations are made – in each case determined by the actual flown distance between the origin and the destination airports.

The actual flown distance between two airports can be derived as a function of the great circle distance (GCD) between the airports in question. The relation between actual distance and GCD flown is taken from the German TREMOD AV model (Knörr et al., 2012). For GCD ≤ 100 NM (≤ 185.2 km), 60 km must be added to the great circle distance (GCD) in order to find actual distance flown. For GCD > 100 NM (>185.2 km), 4 % additional flown distance is added for the part of GCD > 100 NM (>185.2 km):

- Actual flown distance (GCD ≤ 185.2 km) = GCD + 60 km
- Actual flown distance (GCD > 185.2 km) = (GCD - 185.2 km) × 1,04 + 185.2 km + 60 km

If the actual flown distance, y , is smaller than the maximum distance for which fuel consumption and emission data are given in the EMEP/EEA data bank the fuel consumption or emission $E(y)$ becomes:

$$E(y) = E_{x_i} + \frac{(y - x_i)}{x_{i+1} - x_i} \cdot (E_{x_{i+1}} - E_{x_i}) \quad y < x_{\max}, i = 0, 1, 2, \dots, \max-1 \quad (17)$$

In (17) x_i and x_{\max} denominate the separate distances and the maximum distance, respectively, with known fuel consumption and emissions. If the actual flown distance, y , exceeds x_{\max} the maximum figures for fuel consumption and emissions must be extrapolated and the equation then becomes:

$$E(y) = E_{x_{\max}} + \frac{(y - x_{\max})}{x_{\max} - x_{\max-1}} \cdot (E_{x_{\max}} - E_{x_{\max-1}}) \quad y > x_{\max} \quad (18)$$

Total results are summed up and categorised according to each flight's destination airport code in order to distinguish between domestic and international flights.

Annex 3.B.10 shows the average fuel consumption and emission factors per representative aircraft type for cruise flying, as well as total distance flown, for 2020¹⁷. The factors are split between Copenhagen Airport and other airports and distinguish between domestic and international flights.

Specifically for flights between Denmark and Greenland or the Faroe Islands, for each representative aircraft type, the flight distances are directly shown in Annex 3.B.10, which go into the cruise calculation expressions 17 and 18.

The overall fuel precision (fuel balance) in the model is 1.04 in 2020, derived as the fuel ratio between model estimates and statistical sales. The fuel difference is accounted for by adjusting cruising fuel consumption and emissions in the model according to domestic and international cruising fuel shares.

For inventory years before 2001, the calculation procedure is to estimate each year's fuel consumption and emissions for LTO based on LTO/aircraft type statistics from Copenhagen Airport, and total take off numbers for other airports provided by the Danish Transport and Construction Agency. Due to lack of aircraft type specific LTO data, fuel consumption and emission factors derived for domestic LTO's in Copenhagen Airport is used for all LTO's in other airports. In a next step, the total fuel consumption for cruise (true cruise fuel consumption) is found year by year as the statistical fuel consumption total minus the calculated fuel consumption for LTO.

For each inventory year, intermediate cruise fuel consumption figures split into four parts (Copenhagen/Other airports; domestic/international) are found as proportional values between part specific LTO fuel consumption values estimated as described previously, and part specific cruise:LTO fuel consumption ratios for 2001 derived from the detailed city-pair emission inventory.

Each inventory year's true cruise fuel consumption is finally split into four parts by using the intermediate cruise fuel consumption values as a distribution key. As emission factor input data for cruise, aggregated fuel related emission factors for 2001 are derived from the detailed city-pair emission inventory.

Non-road working machinery and recreational craft

Prior to adjustments for deterioration effects and transient engine operations, the fuel consumption and emissions in year X, for a given machinery type, engine size and engine age, are calculated as:

$$E_{Basis}(X)_{i,j,k} = N_{i,j,k} \cdot HRS_{i,j,k} \cdot P \cdot LF_i \cdot EF_{y,z} \quad (19)$$

Where E_{Basis} = fuel consumption/emissions in the basic situation, N = number of engines, HRS = annual working hours, P = average rated engine size in kW, LF = load factor, EF = fuel consumption/emission factor in g pr kWh, i = machinery type, j = engine size, k = engine age, y = engine-size class and z =

¹⁷ Excluding flights for Greenland and the Faroe Islands.

emission level. The basic fuel consumption and emission factors are shown in Annex 3.B.11.

The deterioration factor for a given machinery type, engine size and engine age in year X depends on the engine-size class (only for gasoline), y, and the emission level, z. The deterioration factors for diesel and gasoline 2-stroke engines are found from:

$$DF_{i,j,k}(X) = \frac{K_{i,j,k}}{LT_i} \cdot DF_{y,z} \quad (20)$$

Where DF = deterioration factor, K = engine age, LT = lifetime, i = machinery type, j = engine size, k = engine age, y = engine-size class and z = emission level.

For gasoline 4-stroke engines the deterioration factors are calculated as:

$$DF_{i,j,k}(X) = \sqrt{\frac{K_{i,j,k}}{LT_i}} \cdot DF_{y,z} \quad (21)$$

The deterioration factors inserted in (20) and (21) are shown in Annex 3.B.11. No deterioration is assumed for fuel consumption (all fuel types) or for LPG engine emissions and, hence, DF = 1 in these situations.

The transient factor for any given machinery type, engine size and engine age in year X, relies only on emission level and load factor, and is denominated as:

$$TF_{i,j,k}(X) = TF_z \quad (22)$$

Where i = machinery type, j = engine size, k = engine age and z = emission level.

The transient factors inserted in (22) are shown in Annex 3.B.11. No transient corrections are made for gasoline and LPG engines and, hence, TF_z = 1 for these fuel types.

The final calculation of fuel consumption and emissions in year X for a given machinery type, engine size and engine age, is the product of the expressions 19-22:

$$E(X)_{i,j,k} = E_{Basis}(X)_{i,j,k} \cdot TF(X)_{i,j,k} \cdot (1 + DF(X)_{i,j,k}) \quad (23)$$

The evaporative hydrocarbon emissions from fuelling are calculated as:

$$E_{Evap, fueling_i} = FC_i \cdot EF_{Evap, fueling} \quad (24)$$

Where E_{Evap, fueling} = hydrocarbon emissions from fuelling, i = machinery type, FC = fuel consumption in kg, EF_{Evap, fueling} = emission factor in g NMVOC pr kg fuel.

For tank evaporation, the hydrocarbon emissions are found from:

$$E_{Evap,tank,i} = N_i \cdot EF_{Evap,tank,i} \quad (25)$$

Where $E_{Evap,tank,i}$ = hydrocarbon emissions from tank evaporation, N = number of engines, i = machinery type and $EF_{Evap,fueling}$ = emission factor in g NMVOC pr year.

Ferries, other national sea transport, fisheries and international sea transport

The fuel consumption and emissions in year X , for ferries are calculated as:

$$E(X) = \sum_i N_i \cdot T_i \cdot S_{i,j} \cdot P_i \cdot LF_j \cdot LAF_j \cdot EF_{k,l,y} \quad (26)$$

Where E = fuel consumption/emissions, N = number of round trips, T = sailing time pr round trip in hours, S = ferry share of ferry service round trips, P = engine size in kW, LF = engine load factor, LAF = engine load adjustment factor, EF = fuel consumption/emission factor in g pr kWh, i = ferry service, j = ferry, k = fuel type, l = engine type, y = engine year.

For fishing vessels, the fuel consumption and emissions in year X , are calculated as:

$$E(X) = \sum_i T_i \cdot P_j \cdot LF_j \cdot LAF_j \cdot EF_{k,l,y} \quad (27)$$

Where E = fuel consumption/emissions, T = sailing time pr fishing trip in hours, P = engine size in kW, LF = engine load factor, LAF = engine load adjustment factor, EF = fuel consumption/emission factor in g pr kWh, i = fishing trip no., j = fishing vessel registration no., k = fuel type, l = engine type, y = engine year.

For the remaining navigation categories, the emissions are calculated using a simplified approach:

$$E(X) = \sum_i EC_{i,k} EF_{k,l,y} \quad (28)$$

Where E = fuel consumption/emissions, EC = energy consumption, EF = fuel consumption/emission factor in g per kg fuel, i = category (other national sea, international sea), k = fuel type, l = engine type, y = average engine year.

The emission factor inserted in (28) is found as an average of the emission factors representing the engine ages which are comprised by the average lifetime in a given calculation year, X :

$$EF_{k,l,y} = \frac{\sum_{year=X-LT}^{year=X} EF_{k,l}}{LT_{k,l}} \quad (29)$$

Other sectors

For military and railways, the emissions are estimated with the simple method using fuel-related emission factors and fuel consumption from the DEA:

$$E = FC \cdot EF \quad (30)$$

where E = emission, FC = fuel consumption and EF = emission factor. The calculated emissions for other mobile sources are shown in CollectER format in Annex 3.B.16 for the years 1990 and 2020 and as time series 1990-2020 in Annex 3.B.15 (CRF format).

Fuel balance between DEA statistics and inventory estimates

Following convention rules, the DEA statistical fuel sales figures are the basis for the full Danish inventory. However, in some cases for mobile sources the DEA statistical sectors do not fully match the inventory sectors.

In the following, the transferal of fuel consumption data from DEA statistics into inventory relevant categories is explained for national sea transport and fisheries, non-road machinery and recreational craft, and road transport. A full list of all fuel consumption data, DEA figures as well as intermediate fuel consumption data, and final inventory input figures is shown in Annex 3.B.14.

National sea transport and fisheries

Fuel used for the remaining part of the traffic between two Danish ports, other national sea transport, is taken as the difference between 1) DEA national fuel sales for national sea transport minus fuel consumption at Danish off shore installations (off shore reduced fuel sales¹⁸) and 2) the bottom-up calculated fuel consumption for Danish ferries.

For years when the fuel estimates for ferries (not including the ferry to the Faroe Islands) are higher than the “off shore reduced” fuel sold for national sea transport, fuel is taken from fisheries in the case of marine diesel (1985-1999). For heavy fuel oil, the missing fuel amount is taken from stationary sources (1985-1986, 1988, 1994-1996) and international sea transport (2015 onwards).

For fisheries, the calculation methodology is activity based with a fuel balance, and input fuel data is in principle the diesel fuel sold for fisheries reported by DEA.

For years when diesel fuel calculated for national sea transport are higher than the “Off shore reduced” fuel sold for national sea transport, diesel is transferred from fisheries to national sea transport in the inventories.

In addition, the bottom up diesel estimate for recreational craft is subtracted from fisheries and grouped in the “Other” inventory category together with military activities. Incorrectly reported gasoline and heavy fuel oil for fisheries is transferred to recreational craft (reported under “Other”) and national sea transport, respectively.

According to the DEA, in some cases inaccurate costumer specifications are made by the oil suppliers, which result in sector misallocation in the sales statistics between national sea transport and fisheries for diesel oil and between national sea transport and industry for heavy fuel oil (Peter Dal, DEA, personal communication, 2007). Further, fuel sold for vessels sailing between Denmark and Greenland/Faroe Islands are reported as international in the

¹⁸ According to the Danish Energy Authority, the latter diesel fuel sales are reported as sold for national navigation by the fuel sales reporting oil companies.

DEA statistics, and this fuel categorisation is different from the IPCC guideline definitions (see following paragraph “Bunkers”).

Inaccurate fuel sale specifications is also the reason for heavy fuel oil being reported for fisheries in the DEA statistics. No engines installed in fishing vessels use heavy fuel oil, even though a certain amount of heavy fuel oil is listed in the DEA numbers for some statistical years (H. Amdissen, Danish Fishermen's Association, personal communication, 2006).

Non-road machinery and recreational craft

For diesel and LPG, the non-road fuel consumption estimated by DCE is partly covered by the fuel consumption amounts in the following DEA sectors: agriculture and forestry, market gardening, and building and construction. The remaining quantity of non-road diesel and LPG is taken from the DEA industry sector.

For gasoline, the DEA residential sector, together with the DEA sectors mentioned for diesel and LPG, contribute to the non-road fuel consumption total. In addition, a certain amount of fuel is transferred from DEA road transport in order to outbalance the bottom up fuel consumption calculated in the DCE model.

The amount of diesel and LPG in DEA industry not being used by non-road machinery is included in the sectors, “Combustion in manufacturing industry” (0301) and “Non-industrial combustion plants” (0203) in the Danish emission inventory.

For recreational craft, the calculated fuel consumption totals for diesel and gasoline in the DCE model are subsequently subtracted from the DEA fishery sector. For gasoline, the DEA reported fuel consumption for fisheries is far too small to outbalance the bottom up fuel consumption for recreational craft, and hence the missing fuel amount is taken from the DEA road transport sector in order to fill the fuel gap.

Road transport

For LPG, the difference between fuel reported in DEA statistics and bottom-up estimates for road transport is outbalanced with fuel totals from “non-industrial combustion plants” (020200) in order to obtain a fuel balance.

Distinction between domestic and international aviation and navigation for Denmark

The distinction between domestic and international fuel consumption and emissions from aviation and navigation for Denmark should be in accordance with the 2006 IPCC Guidelines for National Greenhouse Gas Inventories. For the national emission inventory, this, in principle, means that fuel sold (and associated emissions) for flights/sea transportation starting from a seaport/airport in the Kingdom of Denmark, with destinations inside or outside the Kingdom of Denmark, are regarded as domestic or international, respectively.

Aviation

As prescribed by the IPCC guidelines, for aviation, the fuel consumption and emissions associated with flights inside the Kingdom of Denmark are counted as domestic.

This report includes flights from airports in Denmark and associated jet fuel sales. Hence, the flights between airports in Denmark and flights from Denmark to Greenland and the Faroe Islands are classified as domestic and flights from Danish airports with destinations outside the Kingdom of Denmark are classified as international flights.

In Greenland and in the Faroe Islands, the jet fuel sold is treated as domestic. This decision becomes reasonable when considering that almost no fuel is bunkered in Greenland/the Faroe Islands by flights other than those going to Denmark.

Navigation

In DEA statistics, the domestic fuel total consists of fuel sold to Danish ferries and other ships sailing between two Danish ports. The DEA international fuel total consists of the fuel sold in Denmark to international ferries, international warships, other ships with foreign destinations, transport to Greenland and the Faroe Islands, tank vessels and foreign fishing boats.

In order to follow the IPCC guidelines the bottom-up fuel estimates for the ferry routes between Denmark and the Faroe Islands, and fuel sold in Denmark to vessels engaged in freight transportation between Denmark and Greenland/Faroe Islands are being subtracted from the fuel sales figures for international sea transport prior to inventory fuel input.

In Greenland, all marine fuel sales are treated as domestic. In the Faroe Islands, fuel sold in Faroese ports for Faroese fishing vessels and other Faroese ships is treated as domestic. The fuel sold to Faroese ships bunkering outside Faroese waters and the fuel sold to foreign ships in Faroese ports or outside Faroese waters is classified as international (Lastein and Winther, 2003).

Conclusively, the domestic/international fuel split (and associated emissions) for navigation is not determined with the same precision as for aviation. It is considered, however, that the potential of incorrectly allocated fuel quantities is only a small part of the total fuel sold for navigational purposes in the Kingdom of Denmark.

3.3.5 Uncertainties and time series consistency

Tier 1 uncertainty estimates for greenhouse gases, are made for road transport and other mobile sources using the guidelines formulated in the 2006 IPCC Guidelines for National Greenhouse Gas Inventories (IPCC, 2006). For road transport, railways and fisheries, these guidelines provide uncertainty factors for activity data that are used in the Danish situation. For other sectors, the factors reflect specific national knowledge (Winther et al., 2006 and Winther, 2008). These sectors are (SNAP categories): Inland Waterways (a part of 1A3d: Navigation), Agriculture and Forestry (parts of 1A4c: Agriculture-/forestry/fisheries), Industry (mobile part of (1A2f: Industry-other), Residential (1A4b) and National sea transport (a part of 1A3d: Navigation).

The activity data uncertainty factor for civil aviation is based on expert judgement.

The calculations for Tier 1 are shown in Annex 3.B.17 for all emission components.

Table 3.3.20 Tier 1 Uncertainties for activity data, emission factors and total emissions in 2020 and as a trend.

Category	Activity data	%		
		CO ₂	CH ₄	N ₂ O
Road transport	2	5	40	50
Military	2	5	100	1000
Railways	2	5	100	1000
Navigation (small boats)	41	5	100	1000
Navigation (large vessels)	11	5	100	1000
Fisheries	2	5	100	1000
Agriculture	24	5	100	1000
Forestry	30	5	100	1000
Industry (mobile)	41	5	100	1000
Residential	35	5	100	1000
Commercial/Institutional	35	5	100	1000
Civil aviation	10	5	100	1000
Overall uncertainty in 2020		4.8	29.7	102.5
Trend uncertainty		4.2	2.0	50.5

As regards time series consistency, background flight data cannot be made available on a city-pair level prior to 2000. However, aided by LTO/aircraft statistics for these years and the use of proper assumptions, a good level of consistency is in any case, obtained for this part of the transport inventory.

The time series of emissions for mobile machinery in the agriculture, forestry, industry, household and gardening (residential) and inland waterways (part of navigation) sectors are less certain than time series for other sectors, since DEA statistical figures do not explicitly provide fuel consumption information for working equipment and machinery.

3.3.6 Quality assurance/quality control (QA/QC)

The intention is to publish every second year a sector report for road transport and other mobile sources. The last sector report prepared concerned the 2018 inventory (Winther, 2020).

The QA/QC descriptions of the Danish emission inventories for transport follow the general QA/QC description for DCE in Section 1.6, based on the prescriptions given in the IPCC Good Practice Guidance and Uncertainty Management in National Greenhouse Gas Inventories (IPCC, 2000). A general QA/QC plan for the Danish greenhouse gas inventory has been elaborated by Nielsen et al. (2012).

An overview diagram of the Danish emission inventory system is presented in Figure 1.2 (Data storage and processing levels), and the exact definitions of Critical Control Points (CCP) and Points of Measurements (PM) are given in Section 1.6. The status for the PMs relevant for the mobile sector are given in the following text and the result of this investigation indicates a need for future QA/QC activities in order to fulfil the QA/QC requirements from the IPCC GPG.

Data storage level 1

Data Storage level 1	3.Completeness	DS.1.3.1	Documentation showing that all possible national data sources are included by setting down the reasoning behind the selection of datasets.
----------------------	----------------	----------	--

The following external data sources are used in the mobile part of the Danish emission inventories for activity data and supplementary information:

- Danish Energy Agency: Official Danish energy statistics.
- National sea transport (Royal Arctic Line, Eim Skip): Annual fuel consumption data.
- DTU Transport: Road traffic vehicle fleet and mileage data.
- Danish Civil Aviation and Railway Authority: Flight statistics.
- Non-road machinery: Information from statistical sources, research organisations, different professional organisations and machinery manufacturers.
- Ferries (Statistics Denmark): Data for annual return trips for Danish ferry routes.
- Ferries (Danish Ferry Historical Society): Detailed technical and operational data for specific ferries.
- Ferries (Mols Linjen, Bornholmstrafikken, Langelandstrafikken, Færgeselskabet Læsø, Samsø Rederi, Ærøfærgerne A/S, Smyril Line): Detailed technical and operational data for specific ferries.
- Danish Meteorological Institute (DMI): Temperature data.
- The National Motorcycle Association: 2-wheeler data.

The emission factors come from various sources:

- Danish Energy Agency: CO₂ emission factors (all fuel types, except diesel, CNG and LPG) and lower heating values (all fuel types, except CNG, LNG, bio gas).
- COPERT 5: Road transport (all exhaust components, except CO₂, SO₂).
- Handbook of Emission Factors (fuel consumption factors for vans, fuel consumption factors for plug-in passenger cars).
- Danish State Railways: Diesel locomotives (NO_x, VOC, CO and TSP).
- IPCC: CO₂ emission factors for diesel
- Energinet.dk: CO₂ emission factors for CNG, LNG, bio gas.
- EMEP/EEA guidebook: Civil aviation and supplementary.
- ICAO: Civil aviation auxiliary power units.
- Non-road machinery: References given in NERI reports.
- National sea transport and fisheries: TEMA2015 (NO_x, VOC, CO and TSP), IMO (TSP), MAN Energy Solutions (sfc, NO_x), specific data from Mols Linjen (NO_x, CO, NMVOC, TSP) and LNG emission factors (NO_x, CO, NMVOC, TSP) from Bengtsson et al. (2011).

Table 3.3.21 to follow contains Id, File/Directory/Report name, Description, Reference and Contacts. As regards File/Directory/Report name, this field refers to a file name for Id when all external data (time series for the existing inventory) are stored in one file. In other cases, a computer directory name is given when the external data used are stored in several files, e.g. each file contains one inventory year's external data or each file contains time series of external data for sub-categories of machinery. A third situation occurs when the external data are published in publicly available reports; here the aim is to obtain electronic copies for internal archiving.

Table 3.3.21 Overview table of external data and contact persons for transport.

Id no	File-/Directory/- Report name	Description	Activity data or emission factor	Reference	Contacts	Data agreement
T1	Transport energy ¹	Dataset for all transport energy use	Activity data	The Danish Energy Agency (DEA)	Jane Rusbjerg	Yes
T2	Fleet and mileage data ²	Road transport fleet and mileage data	Activity data	DTU Transport	Thomas Jensen	Yes
T3	Flight statistics ²	Data records for all flights	Activity data	Danish Civil Aviation and Railway Authority	Michael Weber	Yes
T4	Non-road machinery ²	Stock and operational data for non-road machinery	Activity data	Non-road Documentation report		No
T5	Emissions from ships ³	Data for ferry traffic	Activity data	Statistics Denmark	Heidi Sørensen	No
T6	Emissions from ships ³	Technical and operational data for Danish ferries	Activity data	Navigation emission documentation report	Hans Otto Kristensen	No
T7	Temperature data ³	Monthly average of daily max/min temperatures	Other data	Danish Meteorological Institute	Danish Meteorological Institute	No
T8	Fleet and mileage data ¹	Stock data for mopeds and motorcycles	Activity data	The National Motorcycle Association	Henrik Markamp	No
T9	CO ₂ emission factors ¹	DEA CO ₂ emission factors (all fuel types)	Emission factor	The Danish Energy Agency (DEA)	Jane Rusbjerg	No
T10	COPERT 5 emission factors ²	Road transport emission factors	Emission factor	Laboratory of applied thermodynamics Aristotle University Thessaloniki	Leonidas Ntziachristos	No
T11	Railways emission factors ¹	Emission factors for diesel locomotives	Emission factor	Danish State Railways	Jesper Mølgård	Yes
T12	EMEP/EEA guidebook ³	Emission factors for navigation, civil aviation and supplementary	Emission factor	European Environment Agency	European Environ- ment Agency	No
T13	Non-road emission factors ³	Emission factors for agriculture, forestry, industry and house- hold/gardening	Emission factor	Non-road Documentation report		No
T14	Emissions from ships ³	Emission factors for national sea transport and fisheries	Emission factor	Navigation emission documentation report		No
T15	Fishery activity statistics	Electronic trip-level data for fishing vessels	Activity data	Danish Fisheries Agency	Frank Hernov	No

¹⁾ File name;

²⁾ Directory in the DCE data library structure; ³⁾ Reports available on the internet.

Danish Energy Agency (energy statistics)

The official Danish energy statistics are provided by the Danish Energy Agency (DEA) and are regarded as complete on a national level. For most transport sectors, the DEA subsector classifications fit the SNAP classifications used by DCE.

For non-road machinery, this is however not the case, since DEA do not distinguish between mobile and stationary fuel consumption in the subsectors relevant for non-road mobile fuel consumption.

In this case, DCE calculates a bottom-up non-road fuel consumption estimate and for diesel (land-based machinery only) and LPG, the residual fuel quantities are allocated to stationary consumption. For years when bottom up diesel exceed total DEA fuel sales in the relevant DEA fuel categories, the bottom up estimates are adjusted downwards in order to account for fuel sold. For gasoline (land-based machinery) the relevant fuel consumption quantities for the DEA are smaller than the DCE estimates, and the amount of fuel consumption missing is subtracted from the DEA road transport total to account for all fuel sold. For recreational craft, no specific DEA category exists and, in this

case, the gasoline and diesel fuel consumption is taken from road transport and fisheries, respectively.

For years when the fuel estimates for national sea transport are higher than DEA reported fuel sold for national sea transport, fuel is taken from fisheries in the case of marine diesel (1985-1999). For heavy fuel oil, the missing fuel amount is taken from stationary sources (1985-1986, 1988, 1994-1996) and international sea transport (2015 onwards).

In order to maintain the national energy balance, the changes in the fuel consumption time series for national sea transport lead, in turn, to changes in the fuel activity data for fisheries (diesel oil), industry and international sea transport (heavy fuel oil).

The DCE fuel modifications, thus, give DEA-SNAP differences for road transport, national sea transport and fisheries.

A special note must be made for the DEA civil aviation statistical figures. The domestic/international fuel consumption division derives from bottom-up fuel consumption calculations made by DCE.

DTU Transport

Figures for fleet numbers and mileage data are provided by DTU Transport on behalf of the Danish Ministry of Transport. Following the data deliverance contract between DCE and the Danish Ministry of Transport, it is a basic task for DTU Transport to possess comprehensive information on Danish road traffic. The fleet figures are based on data from the Motor Register, kept by Statistics Denmark and are, therefore, regarded as very precise. Annual mileage information is obtained by DTU Transport from the Danish Vehicle Inspection and Maintenance Program.

Danish Civil Aviation and Railway Authority (Former: Civil Aviation Agency of Denmark)

The Danish Civil Aviation and Railway Authority monitors all aircraft movements in Danish airspace and, in this connection, possesses data records for all take-offs and landings at Danish airports. The dataset from 2001 onwards, among others consisting of aircraft type and origin and destination airports for all flights leaving major Danish airports, are, therefore, regarded as very complete. For inventory years before 2001, the most accurate data contain Transport Authority total movements from major Danish airports and detailed aircraft type distributions for aircraft using Copenhagen Airport, provided by the airport itself.

Danish Fisheries Agency

The Danish Fisheries Agency gather data electronic log data for all fishing travels made by Danish fishing vessels, and is regarded as very complete. The data consist of vessel engine size and brutto tonnes, vessel build year, vessel type and the time duration of the fishing travel.

Non-road machinery (stock and operational data)

A great deal of stock and operational data for non-road machinery was obtained in a research project carried out by Winther et al. (2006) for the 2004 inventory. In 2016, a comprehensive data update were made for the most important building and construction machinery concerning engine load factors,

equipment size - engine size relations, equipment scrapping curves and annual working hours as a function of engine age. In 2017, a comprehensive data update were made for the most important household and gardening machinery types concerning new sales data, equipment size - engine size relations, equipment scrapping curves and annual working hours as a function of machinery age, with sales figures validated through discussions with KVL.

In 2021, several comprehensive data updates were made. For tractors, stock data was updated based on data from the Digital Motor Register kept by Statistics Denmark.

For fork lifts, a revision of the stock data was made by including WITS (World Industrial Truck Sales) and FEM (Federation European Material) fork lift sales figures for Denmark in 2000-2020 provided by Toyota Material Handling, to adjust sales data provided by the Association of Producers and Distributors of Fork Lifts in Denmark for 1976-2019.

For forestry non road machinery, a revision of the number of forestry machines, engine size, annual working hours and average life times was made based on data provided by the Danish Forest Association.

The source for the stock of harvesters is Statistics Denmark. Sales figures for harvesters and construction machinery, together with operational data and supplementary information, are obtained from The Association of Danish Agricultural Machinery Dealers and key experts from the most important engine manufacturers.

Stock information disaggregated into vessel types for recreational craft was obtained from the Danish Sailing Association. A certain part of the operational data comes from previous Danish non-road research projects (Dansk Teknologisk Institut, 1992 and 1993; Bak et al., 2003).

Except for tractors, no statistical register exists for non-road machinery types and this affects the accuracy of stock and operational data.

For harvesters, Statistics Denmark provide total stock data based on information from questionnaires and the registers of crop subsidy applications kept by the Ministry of Environment and Food of Denmark. In combination with new sales figures per engine size from The Association of Danish Agricultural Machinery Dealers, the best available stock data are obtained.

In addition, using the data sources for construction machinery, forestry equipment, gasoline fuelled gardening machinery and fork lift sale figures are regarded as the only realistic approach for consolidated stock information for these machinery types.

Total stock estimates and engine lifetime assumptions are used to disaggregate the stock into layers in the case of machinery types (rare types of diesel and gasoline non-road equipment, recreational craft) where data is even scarcer.

To support the 2021 inventory, new 2020 stock data for tractors, forestry equipment, construction machinery, fork lifts and gasoline fuelled garden equipment was obtained from the sources listed in the present report. For

non-road machinery in general, it is, however, uncertain if data in such a level can be provided annually in the future.

Ferries (Statistics Denmark)

Statistics Denmark provides information of annual return trips for all Danish ferry routes from 1990 onwards. The data are based on monthly reports from passenger and ferry shipping companies in terms of transported vehicles passengers and goods. Thus, the data from Statistics Denmark are regarded as complete. Most likely, the data can be provided annually in the future.

Ferries (Danish Ferry Historical Society, DFS)

No central registration of technical and operational data for Danish ferries and ferry routes is available from official statistics. However, one valuable reference to obtain data and facts about construction and operation of Danish ferries, especially in the recent 20 - 30 years is the archives of Danish Ferry Historical Society. Pure technical data has not only been obtained from this society's archives, but some of the knowledge has been obtained through the personal insight about ferries from some of the members of the society, which have been directly involved in the ferry business for example consultants, naval architects, marine engineers, captains and superintendents. However, until recently no documentation of the detailed DFS knowledge was established in terms of written reports or a central database system.

To make use of all the ferry specific data for the Danish inventories, DSF made a data documentation for the years 1990-2005 as a specific task of the research project carried out by Winther (2008).

Ferries (Mols Linjen, Bornholmstrafikken, Langelandstrafikken, Færgeselskabet Læsø, Samsø Rederi, Ærøfærgerne A/S, Smyril Line)

For the years 2006+, the major Danish ferry companies are contacted each year in order to obtain ferry technical data, relating to specific ferries in service, annual share of total round trips and other technical information. The relevant annual information is given as personal communication, a method, which can be repeated in the future.

National sea transport (Royal Arctic Line, Eim Skip)

For the years 2006+, the major shipping companies with frequent sailing activities between Denmark and Greenland/Faroe Islands are contacted each year in order to obtain data for fuel sold in Denmark used for these vessel activities. The relevant annual information is given as personal communication, a method, which can be repeated in the future.

Danish Meteorological Institute

The monthly average max/min temperature for Denmark comes from DMI. This source is self-explanatory in terms of meteorological data. Data are publicly available for each year on the internet.

The National Motorcycle Association

Road transport: 2-wheeler stock information (The National Motorcycle Association). Given that no consistent national data are available for mopeds in terms of fleet numbers and distributions according to engine principle, The National Motorcycle Association is considered the professional organisation, where most expert knowledge is available. The relevant annual information is given as personal communication, a method, which can be repeated in the future.

Danish Energy Agency (CO₂ emission factors and lower heating values)

The CO₂ emission factors and net calorific values (NCV) are fuel-specific constants. The country-specific values from the DEA are used for all inventory years.

COPERT 5

COPERT 5 provides factors for fuel consumption and for all exhaust emission components, which are included in the national inventory. For several reasons, COPERT 5 is regarded as the most appropriate source of road traffic fuel consumption and emission factors. First of all, very few Danish emission measurements exist, so data are too scarce to support emission calculations on a national level. Secondly, most of the fuel consumption and emission information behind the COPERT model are derived from different large European research activities, and the formulation of fuel consumption and emission factors for all single vehicle categories has been made by a group of road traffic emission experts. A large degree of internal consistency is, therefore, achieved. Finally, the COPERT model is regularly updated with new experimental findings from European research programs and, apart from updated fuel consumption and emission factors, the use of COPERT 5 by many European countries ensures a large degree of cross-national consistency in reported emission results.

The Handbook of Emission Factors

The Handbook of Emission Factors is a comprehensive road transport emission model developed by a consortium of research institutes in Germany, Austria, Switzerland, France, Sweden and Norway. A large corporation exist and data exchange activities takes place between Handbook, COPERT 5 and other European emission modellers, with the aims of sharing basis emission and fuel consumption measurement data as basis input for the different emission models. The most recent version of the Handbook is in a few cases more updated in terms of vehicle size-technology splits compared to COPERT 5. This is the case for light commercial vehicles, in which case the Handbook provides the necessary fuel consumption data split into the three vehicle size classes for all relevant fuel types and Euro levels. For plugin passenger cars, fuel consumption data from the Handbook is also used.

Danish State Railways

Aggregated emission factors of NO_x, VOC, CO and TSP for diesel locomotives are provided annually by the Danish State Railways. Taking into account available time resources for subsector emission calculations, the use of data from Danish State Railways is sensible. This operator accounts for around 90 % of all diesel fuel consumed by railway locomotives in Denmark and the remaining diesel fuel is used by various private railways companies. Setting up contacts with the private transport operators is considered a rather time consuming experience taking time away from inventory work in areas of greater emission importance.

EMEP/EEA guidebook

Fuel consumption and emission data from the EMEP/EEA guidebook is the prime and basic source for the aviation and navigation part of the Danish emission inventories. For aviation, the guidebook contains the most comprehensive list of representative aircraft types available for city-pair fuel consumption and emission calculations. The data have been provided by Euro-control (the European aviation safety organization) specifically for detailed national inventory use and was evaluated by the transport expert panel in the

TFEIP (Task Force for Emission Inventories and Projections) under UNECE CLRTAP.

In addition, the EMEP/EEA guidebook is the source of non-exhaust TSP, PM₁₀, PM_{2.5} and BC emission factors for road transport, and the primary source of emission factors for some emission components – typically N₂O, NH₃ and PAH – for other mobile sources.

Non-road machinery (fuel consumption and emission factors)

The references for non-road machinery fuel consumption and emission factors are listed in Winther (2020) and in the present report. The fuel consumption and emission data is regarded as one of the most comprehensive data collections on a European level, having been thoroughly evaluated by German emission measurement and non-road experts in German non-road inventory projects.

National sea transport and fisheries

Emission factors for NO_x, VOC and CO are taken from the TEMA2015 model developed for the Ministry of Transport. To a large extent, the emission factors originate from the exhaust emission measurement programme carried out by Lloyd’s (1995). For TSP, IMO (2015) is the source for the emission factors. For NO_x, additional information of emission factors for engine manufacturing years going back to 1949, as well as NO_x, VOC and CO emission factors for engines built after 2010, was provided by the engine manufacturer MAN Energy Solutions. PM₁₀ and PM_{2.5} fractions of total TSP were also provided by the latter source.

Specifically for the ferries used by Mols Linjen, new NO_x, VOC and CO emission factors are provided by Kristensen (2008), originating from measurement results by Hansen et al. (2004), Wismann (1999) and PHP (1996). Kristensen (2013, 2019) has provided complimentary emission factor data for new ferries.

The experimental work by Lloyd’s is still regarded as the most comprehensive measurement campaign with results publicly available. The additional NO_x and PM₁₀/PM_{2.5} information comes from the world’s largest ship engine manufacturer and data from this source is consistent with data from Lloyd’s. Consequently, the data used in the Danish inventories for national sea transport is regarded as the best available for emission calculations.

Data Storage level 1	1. Accuracy	DS.1.1.1	General level of uncertainty for every dataset, including the reasoning for the specific values
----------------------	-------------	----------	---

The uncertainty involved in the DEA fuel consumption information (except civil aviation) and the Danish Transport and Construction Agency flight statistics is negligible, as such, and this is also true for DMI temperature data. For civil aviation, some uncertainty prevails, since the domestic fuel consumption figures originate from a division of total jet-fuel sales figures into domestic and international fuel quantities, derived from bottom-up calculations. A part of the fuel consumption uncertainties for non-road machines is due to the varying levels of stock and operational data uncertainties, as explained in DS 1.3.1.

As regards emission factors, the CO₂ factors (and NCVs) from the DEA are considered very precise, since they relate only to fuel. For the remaining emission factor sources, the SO₂ (based on fuel sulphur content), NO_x, NMVOC, CH₄, CO, TSP, PM₁₀ and PM_{2.5} emission factors are less accurate. Though many measurements have been made, the experimental data rely on the individual measurement and combustion conditions. The uncertainties for N₂O and NH₃ emission factors are even higher due to the small number of measurements available. For heavy metals and PAH, experimental data are so scarce that uncertainty becomes very high.

A special note, however, must be made for energy. The uncertainties due to the subsequent treatment of DEA data for road transport, national sea transport, fisheries and the non-road relevant sectors, explained in DS 1.3.1, trigger some uncertainties in the fuel consumption figures for these sectors. This point is, though, more relevant for QA/QC description for data processing, Level 1.

Data Storage level 1	2.Comparability	DS.1.2.1	Comparability of the emission factors/calculation parameters with data from international guidelines, and evaluation of major discrepancies.
----------------------	-----------------	----------	--

Work has been carried out to compare Danish figures with corresponding data from other countries in order to evaluate discrepancies. The comparisons have been made on a CRF level, mostly for implied emission factors (Fauser et al., 2007, 2013).

Data Storage level 1	4.Consistency	DS.1.4.1	The origin of external data has to be archived with proper reference.
----------------------	---------------	----------	---

It is ensured that the original files from external data sources are archived internally at DCE. Subsequent raw data processing is carried out either in the DCE database models or in spreadsheets (data processing level 1).

Data Storage level 1	6.Robustness	DS.1.6.1	Explicit agreements between the external institution holding the data and DCE about the condition of delivery
----------------------	--------------	----------	---

For transport, DCE has made formal agreements with regard to external data deliverance with (Table 3.3.21 external data source Id's in brackets): DEA (T1), the Danish Civil Aviation and Railway Authority (T3), Danish State Railways (T9) and DTU Transport (T2).

Data Storage level 1	7. Transparency	DS.1.7.1	Listing of all archived datasets and external contacts
----------------------	-----------------	----------	--

The listing of all archived datasets and external contact persons are given in Table 3.3.21.

Data Processing Level 1

Data Processing level 1	1. Accuracy	DP.1.1.1	Uncertainty assessment for every data source not part of DS.1.1.1 as input to Data Storage level 2 in relation to type and scale of variability.
-------------------------	-------------	----------	--

The general uncertainties of the DEA fuel consumption information, DMI temperature data, road transport stock totals and the Danish Aviation and Railway Authority flight statistics are zero. For domestic aviation fuel consumption, the uncertainty is based on own judgement. For road transport, military and railways the fuel consumption uncertainties are taken from the IPCC Good Practice Guidance manual. It is noted that for road transport, it is not possible to quantify in-depth the uncertainties (1) of stock distribution into COPERT 5 relevant vehicle subsectors and (2) of the national mileage figures, as such.

In the mobile part of the Danish emission inventories, uncertainty assessments are made at Data Processing Level 1 for non-road machinery, recreational craft and national sea transport. For these types of mobile machinery, the stock and operational data variations are assumed to be normally distributed (Winther et al., 2006; Winther, 2008). Tier 1 uncertainty calculations produce final fuel consumption uncertainties ready for Data Storage Level 2 (SNAP level 2: Inland waterways, agriculture, forestry, industry and household-gardening). The sizes of the variation intervals are given for activity data and emission factors in the present report.

For non-road machinery stock and operational data, the uncertainty figures are given in Winther et al. (2006). For navigation, the uncertainty figures are given in Winther (2008).

For emission factors, the uncertainties for mobile sources are determined as suggested in the IPCC and UNECE guidelines. The uncertainty figures are listed in Paragraph 1.1.5 for greenhouse gases, and in Winther et al. (2006) and Winther (2008, 2020) for the remaining emission components.

Data Processing level 1	1. Accuracy	DP.1.2.1	The methodologies have to follow the international guidelines suggested by UNFCCC and IPCC.
-------------------------	-------------	----------	---

An evaluation of the methodological inventory approach has been made, which proves that the emission inventories for transport are made according to the IPCC guidelines (IPCC, 2006). Further, the Danish inventories are reviewed annually by the UNFCCC.

Data Processing level 1	1. Accuracy	DP.1.1.4	Verification of calculation results using guideline values
-------------------------	-------------	----------	--

It has been checked that the greenhouse gas emission factors used in the Danish inventory are within margin of the IPCC guideline values.

Data Processing level 1	3. Completeness	DP.1.3.1	Identification of data gaps with regard to data sources that could improve quantitative knowledge.
-------------------------	-----------------	----------	--

No important areas can be identified.

Data Processing level 1	4. Consistency	DP.1.4.1	Documentation and reasoning of methodological changes during the time series and the qualitative assessment of the impact on time series consistency.
-------------------------	----------------	----------	---

See DP 1.7.5.

Data Processing level 1	5. Correctness	DP.1.5.2	Verification of calculation results using time series
-------------------------	----------------	----------	---

Data Processing level 1	5. Correctness	DP.1.5.3	Verification of calculation results using other measures
-------------------------	----------------	----------	--

For road transport, aviation, navigation and non-road machinery, whether all external data are correctly put into the DCE transport models is checked. This is facilitated by the use of sum queries, which sum up stock data (and mileages for road transport) to input aggregation levels. However, spreadsheet or database manipulations of external data are, in some cases, included in a step prior to this check.

This is carried out in order to produce homogenous input tables for the DCE transport models (road, civil aviation, non-road machinery/recreational craft, navigation/fisheries). The sub-routines perform operations, such as the aggregation/disaggregation of data into first sales year (Examples: Fleet numbers and mileage for road transport, stock numbers for tractors, harvesters and fork lifts) or simple lists of total stock per year (per machinery type for e.g. household equipment and for recreational craft). For civil aviation, additional databases control the allocation of representative aircraft to real aircraft types and the flown distance between airports. A more formal description of the sub-routines will be made.

Regarding fuel data, it is checked for road transport and civil aviation that DEA totals (modified for road) match the input values in the DCE models. For the transport modes military and railways, the DEA fuel consumption figures go directly into Data Storage Level 2. This is also the case for the railway emission factors obtained from Danish State Railways and, generally, for the emission factors, which are kept constant over the years.

The DCE model simulations of fuel consumption and emission factors for road transport, civil aviation, non-road machinery and navigation/fisheries refer to Data Processing Level 1.

When DCE transport model changes are made relating to fuel consumption, it is checked that the calculated fuel consumption sums correspond to the expected fuel consumption levels in the time series. The fuel consumption check also includes a time series comparison with fuel consumption totals calculated in the previous model version. The checks are performed on a SNAP level and, if appropriate, detailed checks are made for vehicle/-machinery technology splits.

As regards model changes in relation to derived emission factors (and calculated emissions), the time series of emission factors (and emissions) are compared to previous model figures. A part of this evaluation includes an assessment, if the development corresponds to the underlying assumptions given by detailed input parameters. Among other things, the latter parameters depend on emission legislation, new technology phase-in, deterioration factors, engine operational conditions/driving modes, gasoline evaporation (hydrocarbons) and cold starts. For methodological issues, please refer to Section 3.3.2.

Data Processing level 1	7.Transparency	DP.1.7.1	The calculation principle, the equations used and the assumptions made must be described
-------------------------	----------------	----------	--

The DCE model calculation principles and basic equations are thoroughly described in the present report, together with the theoretical model reasoning and assumptions. Documentation is also given e.g. in Winther (2001a, 2001b, 2008, 2020) and Winther et al. (2006). Further formal descriptions of DCE model sub routines are given in internal notes, and flow maps show the inter-relations between tables and calculation queries in the models.

During model development, it has been checked that all mathematical model relations give exactly the same results as independent calculations.

Data Processing level 1	7.Transparency	DP.1.7.2	Clear reference to dataset at Data Storage level 1
-------------------------	----------------	----------	--

In the different documentation reports for transport in the Danish emission inventories, there are explicit references for the different external data used.

Data Processing level 1	7.Transparency	DP.1.7.3	A manual log to collect information about recalculations
-------------------------	----------------	----------	--

Recalculation changes in the emission inventories are described in the NIR and IIR reports as a standard. These descriptions take into account changes in emission factors, activity data and calculation methods.

Data Storage Level 2

Data Storage level 2	5.Correctness	DS.2.5.1	Check if a correct data import to level 2 has been made
----------------------	---------------	----------	---

At present, a DCE software program imports data from prepared input data tables (SNAP fuel consumption figures and emission factors) into the CollectER database.

Tables for CollectER fuel consumption and emission results are prepared in a special DCE database (NERIrep.mdb). The results relevant for mobile sources are copied into a database containing all the official inventory results for mobile sources (Data2020 NIR-UNECE.mdb). By the use of database queries, the results from this latter database are aggregated into the same formats as being used by the relevant DCE transport models in their results calculation part. The final comparison between CollectER and DCE transport model results are set up in a spreadsheet.

Data Storage Level 4

Data Storage level 4	4.Consistency	DS.4.4.3	The IEFs from the CRF are checked regarding both level and trend. The level is compared to relevant emission factors to ensure correctness. Large dips/jumps in the time series are explained
----------------------	---------------	----------	---

A spreadsheet "Check CRF 2020.xls" has been set up to check that the fuel consumption and emission totals from CollectER imported in Data2020 NIR-

UNECE.mdb are identical to the fuel consumption and emission totals from the CRF.

3.3.7 Recalculations and improvements

The following recalculations and improvements of the emission inventories have been made since the emission reporting in 2021.

For road transport the following changes have been made.

- Changes in the total fleet numbers for mopeds in 2012-2019 based on new fleet data from DTU Transport.
- Implementation of new emission data from the COPERT V for Euro 5 diesel passenger cars subject to emission reduction software updates due to the diesel scandal. The revised inventory calculations also used the number of included cars in the software update scheme provided by the Danish Safety Technology Authority and engine size and model year information from Volkswagen. The software update scheme took place from 2016-2018, including diesel passenger cars first registered from 2009-2016.
- Gasoline fuel consumption for road transport has slightly increased due to smaller calculated amounts of gasoline used by agricultural tractors before 2006 and ATV's from the mid 1990's and forward, thus having an impact on the gasoline fuel balance made across sectors to account for total fuel sales.

The percentage emission change interval and year of largest absolute percentage differences (low %; high %, year) for the different emission components are: CO₂ (0.1 %, 0.2 %, 2011), CH₄ (-0.2 %; 0.5%, 2011) and N₂O (-0.2 %; 0.4 %, 2010).

Navigation

For navigation the following changes have been made.

- LNG fuel sales in the Danish energy statistics has been substantially revised by the Danish Energy Authority, and a LNG fuel balance is made in the emission model for national navigation to account for total LNG fuel sales.
- Diesel fuel consumption for national sea transport has been reduced in order to account for the diesel fuel used at Danish off shore installations. According to the Danish Energy Authority, the latter diesel fuel sales are reported as sold for national navigation by the fuel sales reporting oil companies.
- The fuel sulphur content for diesel fuel used by the Danish ferry company Molslinjen has been revised for 2019.

The following largest percentage differences (in brackets) for navigation are noted for CO₂ (-8.8 %), CH₄ (-28 %) and N₂O (-9.0 %).

Fisheries

For fisheries the following changes have been made.

- The national emission inventories for fisheries has been upgraded from Tier 1 to Tier 3 for the entire 1985-2020 period. The updated inventories use electronic log data for fishing travels provided by the Ministry of Food, Agriculture and Fisheries of Denmark. The fuel consumption and emissions are calculated for each fishing travel based on vessel engine size, engine load factor, specific fuel consumption/emission factor vessel build year, vessel type and the time duration of the fishing travel. A fuel balance is made in the emission model in order to account for all statistical fuel sold.

The following largest percentage differences (in brackets) for fisheries are noted for CO₂ (-3.7 %), CH₄ (-19 %) and N₂O (-6.0 %).

Agriculture/forestry

For agriculture/forestry the following changes have been made.

- A major revision of the Danish non road emission model has been made based on new stock data from the Danish motor register for tractors used in agriculture, forestry, industry (building and construction, manufacturing industries) and commercial/institutional non road sectors. The stock data consist of fuel type, new sales year, vehicle weight, engine size and branch registration of each tractor, thus enabling a regrouping of the tractors used into the above mentioned inventory sectors.
- A revision of ATV usage and life time expectations has been made in the non road inventory model based on expert judgement from branch experts. This has caused the calculated fuel consumption and emissions for ATV's to decline somewhat during the time the ATV's has been used in Denmark from the mid 1990's and forward.
- Updated stock and utility data for forestry equipment has been provided by the branch organization Danish Forest Association as input for a full revision of the inventory for forestry equipment for the years 1990-2020.

The following largest percentage differences (in brackets) for agriculture/forestry are noted for CO₂ (-39 %), CH₄ (-37 %) and N₂O (-40 %).

Industry

For industry the following changes have been made.

- Emission factors for LPG fueled fork lifts has been updated with new emission data taken from the international literature.
- A revision of the number of new sold trucks in Denmark in the years 2001-2020 and a reallocation of branch usage of the fork lifts for 1985-2020 has been made based on input from Toyota Material Handling. Previously fork lifts were assumed to be occupied in manufacturing industries only, and this has been changed to industry (building and construction, manufacturing industries) and commercial and institutional non road sectors.

- Based on the revision of the Danish non road emission model for tractors, the number of tractors used in industry has been updated according to the branch registration for the individual tractors.

The following largest percentage differences (in brackets) for industry are noted for CO₂ (-18 %), CH₄ (-28 %) and N₂O (-19 %).

Commercial and institutional

For commercial and institutional the following changes have been made.

- A reallocation of branch usage of the fork lifts for the years 1985-2020 has been made based on input from Toyota Material Handling. In the updated inventories some of the fork lifts previously placed in manufacturing industries, has now been reallocated to commercial and institutional.
- Based on the revision of the Danish non road emission model for tractors, the number of tractors used in commercial and institutional has been updated according to the branch registration for the individual tractors.

The following largest percentage differences (in brackets) for commercial and institutional are noted for CO₂ (268 %), CH₄ (91 %) and N₂O (378 %).

Residential

No changes have been made.

Railways

No changes have been made.

Civil aviation

The model used for calculating civil aviation emissions has been updated by replacing the previous fuel consumption and emission factors for representative aircraft types (193 types) with fuel consumption and emission factors for a new and more comprehensive list of representative aircraft types (262 types) provided by Eurocontrol and published in the EMEP/EEA guidebook (EMEP/EEA, 2019).

The following largest percentage differences (in brackets) for civil aviation are noted for CO₂ (7.3 %), CH₄ (93.3 %) and N₂O (3.7 %).

Other (Military and recreational craft)

Updated emission factors derived from the road transport model in the case of military equipment for all years have caused small emission changes from 1985-2019.

The following largest percentage differences (in brackets) for the Other sector are noted for CO₂ (0.1 %), CH₄ (0 %) and N₂O (0.1 %).

3.3.8 Response to the review process

The table below contains the recommendations of the most recent UNFCCC review of the Danish greenhouse gas inventory. The table details the status of implementation of the recommendations as well as references to where improvements have been implemented in this report. A review of the Danish

2020 submission took place in November 2020. At the time of preparing this report, Denmark had not yet received a draft review report. Therefore, the table below represents the latest available report.

Table 3.3.22 Response to the review process.

Para.	CRF	ERT Comment	Denmark's response	Reference
2018 submission (Review report: https://unfccc.int/sites/default/files/resource/dnk_0.pdf)				
	1.A.3.d Domestic navigation – Liquid and gaseous fuels – CO ₂ and CH ₄ (E.4, 2018) Comparability	Reallocate emissions from LNG used in ferries from natural gas liquid to gaseous fuels in CRF table 1.A(a).	The reallocation is made in the 2022 submission.	CRF
	1.A.3.d Domestic navigation – gaseous fuels – CO ₂ and CH ₄ (E.5, 2018) Transparency	Elaborate the estimation method of fuel consumption of LNG for ferries in the NIR, including information on the calorific value used	This was elaborated in the 2021 submission.	NIR report
	1.A.3.a Domestic aviation – gasoline – CH ₄	The Party reported in its NIR (section 3.3.7, p.252) that the source of the EFs for CH ₄ emissions from piston engine aircraft using aviation gasoline was changed to the <i>EMEP/EEA Air Pollutant Emission Inventory Guidebook 2019</i> . However, the <i>EMEP/EEA Air Pollutant Emission Inventory Guidebook 2019</i> does not contain a specific EF for CH ₄ emissions from piston engines. During the review, the Party clarified that the EF for volatile organic compounds, and not the CH ₄ EF, was updated on the basis of the <i>EMEP/EEA Air Pollutant Emission Inventory Guidebook 2019</i> . With regard to the CH ₄ EF for piston engines in aviation, owing to a lack of data, Denmark used fuel-related EFs derived for conventional gasoline engines used in Danish road transport. The Party indicated that it would include a reference to the source of these EFs and additional information in the next NIR. The ERT recommends that the Party revise the incorrect reference to the source of the EFs for CH ₄ emissions from piston engine aircraft using aviation gasoline.	The incorrect EF reference has been revised in the 2021 submission	NIR report
	1.A.3.d Domestic navigation – other fossil fuels – N ₂ O	The Party reported N ₂ O emissions for other fossil fuels (LNG) as “NO” for 1990–2014 and as “NE” for 2015–2018 in CRF table 1.A(a)s3. However, the 2006 IPCC Guidelines (vol. 2, chap. 3, table 3.5.3) provide tier 1 N ₂ O EFs for the category, and after calculating emissions using the tier 1 EF (4 kg/TJ) provided in the 2006 IPCC Guidelines, the ERT found that the Party had underestimated emissions by 0.049 kt CO ₂ eq for 2018, which is below the significance threshold for application of an adjustment in accordance with paragraph 80(b) of decision 22/CMP.1 (annex), in conjunction with decision 4/CMP.11. During the review, the Party stated that it would apply the EF from the 2006 IPCC Guidelines (vol. 2, chap. 3, table 3.5.3) for LNG in its next submission.	The EF from the 2006 IPCC guidelines is used in the 2021 submission.	NIR report

3.3.9 Planned improvements

No planned improvements are envisaged to be made.

QA/QC

Future improvements regarding this issue are dealt with in Section 3.1.4.

3.3.10 References for Chapter 3.3

Amdissen, H., 2020: Unpublished data material for fishing vessels provided by Hanstholm Fisheries Association.

Andersen, C., 2019: Unpublished data material for small ferries.

Bak, F., Jensen, M.G. & Hansen, K.F. 2003: Forurening fra traktorer og ikke-vejgående maskiner i Danmark, Miljøprojekt nr. 779, Miljøstyrelsen (in Danish).

Dansk Teknologisk Institut, 1992: Emission fra Landbrugsmaskiner og Entreprenørmateriel, commissioned by the Danish EPA and made by Miljø Samarbejdet in Århus (in Danish).

Dansk Teknologisk Institut, 1993: Emission fra Motordrevne Arbejdsredskaber og -maskiner, commissioned by the Danish EPA and made by Miljø Samarbejdet in Århus (in Danish).

Bengtsson, S., Andersson, K. & Fridell, E. 2011: A comparative life cycle assessment of marine fuels: liquefied natural gas and three other fossil fuels, 14 pp., Proc. IMechE Vol. 225 Part M: J. Engineering for the Maritime Environment (DOI: 10.1177/1475090211402136).

Bonde, R., 2021: Information of the Euro 5 vehicle recall program provided the Danish Safety Technology Authority.

Brun, I. 2018: Data for fork lifts provided by Toyota Material Handling Danmark A/S.

Christensen, A. 2018: Personal communication, Allan Christensen, N.C. Nielsen A/S.

Christensen, T. 2021: Data for fork lifts provided by Toyota Material Handling Danmark A/S.

Clemmensen, C., 2021: Data for forestry machines provided by the Danish Forest Association).

Cowi, 2008: Model til beregning af vej og banetransportens CO₂-ævivalent emissioner, Technical note, pp. 42, Ministry of Transport (in Danish).

Dávastovu, J. 2010: Unpublished data material from Smyril Line.

DEA, 2021a: The Danish energy statistics, Available at: <https://ens.dk/service/statistik-data-noegletal-og-kort/maanedlig-og-aarlig-energistatistik> (16-03-2022).

DEA, 2021b: Future fuel efficiency improvement rates for passenger cars, vans and trucks provided by the Danish Energy Agency.

Danish Ministry of Taxation, 2015: Status over grænsehandel 2014, pp. 112.

DNV, 2009: Marpol 73/78 Annex VI Regulations for the Prevention of Air Pollution from Ships - Technical and Operational implications, 32 pp.

Ellermann, T., Massling, A., Løfstrøm, P., Winther, M., Nøjgaard, J.K. & Ketznel, M. 2011: Investigation of Air Pollution at the Apron at Copenhagen Airport in Relation to Working Environment (Danish with English summary). DCE e Danish Centre for Environment and Energy, Aarhus University, p. 148. DCE report no. 5. Available at: <http://www.dmu.dk/Pub/TR5.pdf>

EMEP/EEA, 2019: Air Pollutant Emission Inventory Guidebook, prepared by the UNECE/EMEP Task Force on Emissions Inventories and Projections (TFEIP). Available at: <https://www.eea.europa.eu/publications/emep-eea-guidebook-2019> (09-12-2019).

Eriksen, J. 2017: Unpublished data material from Ærøfærgerne A/S.

Fasting, P., 2021: New sales data for building and construction machinery provided by the Association of Danish Agricultural Machinery Dealers.

Faurby, D., 2021: Unpublished data material from Scantruck A/S.

Fausser, P., Thomsen, M., Nielsen, O.K., Winther, M., Gyldenkerne, S., Hoffmann, L., Lyck, E. & Illerup, J.B. 2007: Verification of the Danish emission inventory data by national and international data comparisons. National Environmental Research Institute, University of Aarhus. - NERI Technical Report 627: 53 pp. (electronic). Available at: http://www2.dmu.dk/Pub/FR627_Final.pdf

Fausser, P., Nielsen, M., Winther, M., Plejdrup, M., Gyldenkerne, S., Mikkelsen, M.H., Albrektsen, R., Hoffmann, L., Thomsen, M., Hjelgaard, K. & Nielsen, O.-K. 2013: Verification of the Danish 1990, 2000 and 2010 emission inventory data. Aarhus University, DCE - Danish Centre for Environment and Energy, 85 pp. Scientific Report from DCE - Danish Centre for Environment and Energy No. 79. Available at: <http://dce2.au.dk/pub/SR79.pdf>

Fenhann, J. & Kilde, N.A. 1994: Inventory of Emissions to the air from Danish Sources 1972-1992, 111 pp., ISBN 87-550-1943-9, RISØ National Laboratory.

Hansen, C.O. 2010: Estimation af udenlandske bilers trafikarbejde i Danmark i 2009, Notat nr. 12032-005, 12 pp. Danish Road Directorate, 2010.

Hansen, K.F. & Jensen, M.G. 2004: MÅLING AF EMISSIONER FRA FREM-DRIVNINGSSANLÆG PÅ MADSS MOLS. Ruston 20RK270, Sagsnr.: 1076868, Documentation note, 5 pp. (in Danish).

Helgason, S.H. 2020: Fuel purchase data provided by Eim Skip.

Hernov, F., 2021: Unpublished trip-level activity data for Danish fishing vessels provided by the Danish Fisheries Agency.

Hjelgaard, K. & Winther, M. 2011: The estimated new sales of Euro V diesel trucks equipped with EGR and SCR during the 2006-2010 time periods. Internal DCE note (unpublished). 2 pp. (in Danish).

Hjortshøj, T., 2021. Engine size and model year information provided by Thomas Hjortshøj, Volkswagen, 2021.

ICAO, 2008: ICAO Annex 16 "International standards and recommended practices, Environmental protection", Volume II "Aircraft engine emissions", 3rd ed. (2008) plus amendments, 108 pp., International Civil Aviation Organization, ISBN 978-92-9231-123-0.

ICAO, 2017: ICAO Annex 16 "International standards and recommended practices, Environmental protection", Volume III "Aeroplane CO₂ emissions", 28 pp., International Civil Aviation Organization.

ICAO, 2011: Airport Air Quality Manual (doc. 9889), first ed. International Civil Aviation Organization. ISBN 978-92-9231-862-8.

ICCT, 2017: International Civil Aviation Organization's CO₂ standard for new aircraft, ICCT Policy update, 8 pp., International Council on Clean Transportation, 2017.

IFEU, 2004: Entwicklung eines Modells zur Berechnung der Luftschadstoffemissionen und des Kraftstoffverbrauchs von Verbrennungsmotoren in mobilen Geräten und Maschinen - Endbericht, UFOPLAN Nr. 299 45 113, pp. 122, Heidelberg.

IFEU 2009: Aktualisierung des Modells TREMOD - Mobile Machinery (TREMOD-MM), Endbericht; Institut für Energie- und Umweltforschung, pp. 48, Heidelberg.

IFEU 2014: Erarbeitung eines Konzepts zur Minderung der Umweltbelastung aus NRMM (non-road mobile machinery) unter Berücksichtigung aktueller Emissionsfaktoren und Emissionsverminderungsoptionen für den Bestand, ISSN 1862-4804, Texte 24/2014, pp. 99, Heidelberg.

IMO, 2015: Third IMO GHG Study 2014. Smith, T.W.P., Jalkanen, J.P., Anderson, B.A., Corbett, J.J., Faber, J., Hanayama, S., O'Keeffe, E., Parker, S., Johansson, L., Aldous, L., Raucci, C., Traut, M., Ettinger, S., Nelissen, D., Lee, D.S., Ng, S., Agrawal, A., Winebrake, J.J., Hoen, M., Chesworth, S. & Pandey, A. 2015: International Maritime Organization, (IMO) London, UK, April 2015. Available at: <http://www.imo.org/en/OurWork/Environment/Pollution-Prevention/AirPollution/Documents/Third%20Greenhouse%20Gas%20Study/GHG3%20Executive%20Summary%20and%20Report.pdf>

IPCC, 2006: 2006 IPCC Guidelines for National Greenhouse Gas Inventories, Prepared by the National Greenhouse Gas Inventories Programme, Eggleston, S., Buendia L., Miwa K., Ngara T. & Tanabe K. (eds). Published: IGES, Japan. Available at: <http://www.ipcc-nggip.iges.or.jp/public/2006gl/index.html> (21-02-2014).

Jensen, E. 2016: Unpublished data material from Scantruck A/S.

- Jensen, T.C. 2021: Dokumentation af konvertering af trafiktal til emissionsopgørelser, arbejdsnotat 81834, 38 pp. DTU Transport, 2021.
- Johnsen, T. 2018: Personal communication, Thomas Johnsen, The Danish Bicycle Traders Association.
- Jørgensen, H. 2017: Unpublished data material from Færgen A/S.
- Knörr, W., Schacht, A. & Göres, S. 2012: Entwicklung eines Modells zur Berechnung der Energieeinsätze und Emissionen des zivilen Flugverkehrs – TREMOD AV, Texte 48/2012, ISSN 1862-4804, 66 pp., Umweltbundesamt.
- Kristensen, F. 2008: Unpublished data material from Mols-Linjen.
- Kristensen, F. 2013: Unpublished data material from Mols-Linjen.
- Kristensen, F. 2015: Unpublished data material from Mols-Linjen.
- Kristensen, H.O. 2017: Unpublished data material for small ferries provided by Naval Engineer Hans Otto Holmegaard Kristensen.
- Kruse, C. 2015: Unpublished data material from Samsø Rederi.
- Lastein, L. & Winther, M. 2003: Emission of greenhouse gases and long-range transboundary air pollutants in the Faroe Islands 1990-2001. National Environmental Research Institute. - NERI Technical Report 477: 62 pp. (electronic). Available at:
http://www2.dmu.dk/1_viden/2_Publikationer/3_fagrappporter/rapporter/FR477.pdf
- Lloyd's Register, 2012: Implementing the Energy Efficiency Design Index Version 3.0, December 2012, pp. 22.
- Markamp, H. 2013: Personal communication, Henrik Markamp, The National Motorcycle Association.
- Matzer C., Weller K., Dippold M., Lipp S., Röck M., Rexeis M. & Hausberger S. 2019: Update of emission factors for HBEFA Version 4.1; Final report, I-05/19/CM EM-I-16/26/679 from 09.09.2019, TU Graz.
- Mikkelsen, B. 2016: Unpublished data material from Pon equipment.
- Ministry of Transport, 2015: TEMA2015 - et værktøj til at beregne transporters energiforbrug og emissioner i Danmark (TEMA2015 - a calculation tool for transport related fuel use and emissions in Denmark). Technical report. 126 pp.
- Mortensen, L. 2015: Unpublished data material from Færgeselskabet Læsø.
- Mølgård, J. 2021: Unpublished data material from the Danish State Railways.
- Møller, K. 2015: Unpublished data material from Ærøfærgerne A/S.
- Nielsen, D. 2019: Unpublished emission data material provided by Mols-Linjen.

- Nielsen, D. 2021: Unpublished data material from Mols-Linjen.
- Nielsen, M. & Schösser, M., 2016: Unpublished data material from LTEH (Dealers Association of Electric Tools and Gardening Machinery (In Danish: Leverandørforeningen for Transportabelt Elværktøj og Havebrugsmaskiner).
- Nielsen, O.-K., Plejdrup, M.S., Winther, M., Gyldenkærne, S., Thomsen, M., Fauser, P., Nielsen, M., Mikkelsen, M.H., Albrektsen, R., Hjelgaard, K., Hoffmann, L. & Bruun, H.G. 2012: Quality manual for the Danish greenhouse gas inventory. Version 2. Aarhus University, DCE – Danish Centre for Environment and Energy, 44 pp. Scientific Report from DCE – Danish Centre for Environment and Energy No. 47. Available at: <http://www2.dmu.dk/Pub/SR47.pdf>
- Nielsen, O.-K., Plejdrup, M.S., Winther, M., Mikkelsen, M.H., Nielsen, M., Gyldenkærne, S., Fauser, P., Albrektsen, R., Hjelgaard, K.H., Bruun, H.G. & Thomsen, M. 2021. Annual Danish Informative Inventory Report to UNECE. Emission inventories from the base year of the protocols to year 2019. Aarhus University, DCE – Danish Centre for Environment and Energy, 580 pp. Scientific Report No. 435. Available at: <http://dce2.au.dk/pub/SR435.pdf>
- Notter, B. and Schmied, M. 2015: Non-road energy consumption and pollutant emissions. Study for the period from 1980 to 2050. Federal Office for the Environment, Bern, 237 pp. Environmental studies no. 1519. Available at: [Non-road energy consumption and pollutant emissions \(admin.ch\)](http://www.admin.ch).
- PHP, 1996: Research Report – Emission tests at Alpha, Mols 2 and Mols 4, 9L25MC mk6 engines #35031 and #35033, 22-23/10 1995 and 16/1 1996, DOK, PHP Basic Research, October 1996, 20 pp.
- Prince, M. 2021: Unpublished data material for unregistered mopeds, Prince legal advisers.
- Rasmussen, T. 2017: Unpublished data material for small ferries.
- Rasmussen, H. 2021: Fuel purchase data from Royal Arctic Line.
- Rubek, F., Scharling, M. & Cappelen, J. 2021: The Climate of Denmark 2020 - with English summary, Technical report No 21-01, pp. 78, Danish Meteorological Institute.
- Sempos, 2019: Note on fossil carbon content in biofuels, pp. 13.
- Sjøgren, P. 2016: Unpublished data material from Volvo Construction Equipment.
- Starcrest, 2013: Port of Los Angeles Inventory of Air Emissions – 2012. Available at: http://www.portoflosangeles.org/pdf/2012_Air_Emissions_Inventory.pdf
- Statistics Denmark, 1974: Agricultural statistics 1974, Statistiske meddelelser 1975:13, Statistics Denmark. Available at: [Publikation: Landbrugsstatistik 1974 - Danmarks Statistik \(dst.dk\)](http://dst.dk).

- Statistics Denmark, 2021a: Tractor stock data for 2003-2020 provided by Marie Louise Bak, Statistics Denmark.
- Statistics Denmark, 2021b: Tractor stock data for 1950-2009 provided by Henriette Moric Ingemann, Statistics Denmark.
- Statistics Denmark, 2021c: Number of tractors and harvesters 1982-2005 from Statbank Denmark (Table MASK). Available at:
<http://www.statistikbanken.dk/statbank5a/default.asp?w=1364>
- Statistics Denmark, 2021d: Ferry traffic data from Statbank Denmark (Table SKIB31). Available at:
<http://www.statistikbanken.dk/statbank5a/default.asp?w=1364>
- Tietge, U., Mock, P., Franco, V. & Zacharof, N. 2017: From laboratory to road: Modeling the divergence between official and real world fuel consumption and CO₂ emission values in the German passenger car market for the years 2001-2014, *Energy Policy* 103 (2017) 212-222. Available at:
<http://dx.doi.org/10.1016/j.enpol.2017.01.021>
- Tietge, U., Díaz, S., Mock, P., Bandivadekar, A., Dornoff, J. & Ligterink, N. 2019: From laboratory to road. A 2018 update of official and “real world” fuel consumption and CO₂ values for passenger cars in Europe, ICCT White paper, 56 pp., International Council on Clean Transportation, 2019.
- Winther, M. & Ekman, B. 1998: Emissioner fra vejtrafikken i Danmark 1980-2010. Danmarks Miljøundersøgelser, Aarhus Universitet, 1998. 73 s. (Faglig rapport fra DMU, Vol. 256).
- Winther, M. 2001a: 1998 Fuel Use and Emissions for Danish IFR Flights. Environmental Project no. 628, 2001. 112 pp. Danish EPA. Prepared by the National Environmental Research Institute, Denmark. Available at:
<http://www.mst.dk/udgiv/Publications/2001/87-7944-661-2/html/>
- Winther, M. 2001b: Improving fuel statistics for Danish aviation. National Environmental Research Institute, Denmark. 56 pp. - NERI Technical Report No. 387. Available at:
http://www2.dmu.dk/1_viden/2_Publikationer/3_fagrapporter/rapporter/FR387.pdf
- Winther, M. & Nielsen, O.K. 2006: Fuel use and emissions from non-road machinery in Denmark from 1985-2004 - and projections from 2005-2030. The Danish Environmental Protection Agency. - Environmental Project 1092: 238 pp.
- Winther, M. 2008: Fuel consumption and emissions from navigation in Denmark from 1990-2005 - and projections from 2006-2030. Technical Report from NERI no. 650. 109 pp. Available at: <http://www2.dmu.dk/Pub/FR650.pdf>
- Winther, M. 2009: Emission Differences between Petroleum based Diesel and different Biodiesel Blend Ratios for Road Transport Vehicles. / Winther, Morten. 2009. Transport and Air Pollution Symposium - 3rd Environment and Transport Symposium, no. 17, Toulouse, France, 2-4 June 2009.

Winther, M. 2011: Ændring i partikelemission som følge af fremskyndet salg af Euro 5 biler og retrofit af filtre på tunge køretøjer. Internal DCE note (unpublished). 2 p. (in Danish).

Winther, M., Møller, F. & Jensen, T.C. 2012: Emission consequences of introducing bio ethanol as a fuel for gasoline cars, *Atmospheric Environment* 55 (2012) 144-153.

Winther, M., Kousgaard, U., Ellermann, T., Massling, A., Nøjgaard, J.K. & Ketzel, M. 2015: Emissions of NO_x, particle mass and particle numbers from aircraft main engines, APU's and handling equipment at Copenhagen Airport, *Atmospheric Environment* 100 (2015) 218-229.

Winther, M. 2020: Danish emission inventories for road transport and other mobile sources. Inventories until the year 2018. Aarhus University, DCE – Danish Centre for Environment and Energy, 132pp. Scientific Report from DCE – Danish Centre for Environment and Energy No. 411. Available at: <http://dce2.au.dk/pub/SR411.pdf>

Winther, M. & Martinsen, L. 2020. Analyse af CO₂-emissioner og økonomi ved grøn omstilling af fiskefartøjer. Aarhus Universitet, DCE – Nationalt Center for Miljø og Energi, 36 s. - Videnskabelig rapport nr. 431 [Analyse af CO₂ emissioner og økonomi ved grøn omstilling af fiskefartøjer \(au.dk\)](#).

Wismann, T. 1999: MOLS-LINIEN, Mai Mols - Måling af emissioner fra hovedturbiner, dk-RAPPORT 14.901, 9 pages (in Danish).

3.4 Additional information, CRF sector 1A Fuel combustion

3.4.1 Reference approach, feedstocks and non-energy use of fuels

In addition to the sector specific CO₂ emission inventories (the sectoral approach - SA), the CO₂ emission is also estimated using the reference approach (RA) described in the IPCC Guidelines (IPCC, 2006). The reference approach is based on data for fuel production, import, export and stock change. The CO₂ emission inventory based on the reference approach is reported to the Climate Convention and used for verification of the sectoral approach.

Methodology and data input

Data for import, export and stock change used in the reference approach originate from the annual “basic data” table prepared by the Danish Energy Agency (DEA) and published on their home page (DEA, 2021a). The fraction of carbon oxidised has been assumed 1.00.

The applied carbon emission factors are equal to the emission factors also applied in the sectoral approach and thus include nationally referenced emission factors. This is in agreement with the 2006 IPCC Guidelines.

The Climate Convention reporting tables include a comparison of the sectoral approach and the reference approach estimates.

The consumption for non-energy purposes is subtracted in the reference approach, because non-energy use of fuels is included in other sectors (2D Non-energy products from fuels and solvent use) in the Danish sectoral approach. Three fuels are used for non-energy purposes: lubricants, bitumen and white

spirit. The total consumption for non-energy purposes is relatively low; in 2020, the consumption was 9.5 PJ.

The CO₂ emission from oxidation of lube oil during use was 31.7 kt in 2020 and this emission is reported in the sector Non-energy products from fuels and solvent use (sector 2D). The reported emission corresponds to 20 % of the CO₂ emission from lube oil consumption assuming full oxidation. This is in agreement with the methodology for lube oil emissions in the 2006 IPCC Guidelines (IPCC, 2006). Methodology and emission data for lube oil are shown in NIR Chapter 4.5.3.

For white spirit, the CO₂ emission is indirect as the emissions occur as NMVOC emissions from the use of white spirit as a solvent. The indirect CO₂ emission from solvent use was 69.2 kt in 2020. The methodology and emission data for white spirit are included in NIR Chapter 4.5.4.

The CO₂ emission from bitumen is included in sector 2.D.3, Road paving with asphalt and Asphalt roofing. The total CO₂ emissions for these sectors are 0.91 kt in 2020. Methodology and emission data for non-energy use of bitumen are shown in NIR Chapter 4.5.6.

Results

The sectoral approach and the reference approach have been compared and the differences between the two approaches are shown in Table 3.4.1 below.

Table 3.4.1 Difference between sectoral approach and reference approach.

Year	Difference	Difference
	Energy consumption [%]	CO ₂ emission [%]
1990	0.28	-0.36
1991	-0.55	-0.99
1992	-0.02	-0.67
1993	-0.40	-1.04
1994	-0.31	-0.92
1995	-0.56	-0.97
1996	-0.48	-0.79
1997	-0.03	-0.16
1998	1.50	1.30
1999	-0.58	-0.92
2000	0.27	0.02
2001	0.75	0.60
2002	0.05	-0.16
2003	0.10	-0.10
2004	0.00	-0.20
2005	-0.88	-0.95
2006	-0.69	-0.92
2007	-0.96	-1.09
2008	-0.21	-0.39
2009	-1.67	-1.81
2010	0.08	-0.29
2011	-1.03	-1.18
2012	-1.57	-1.99
2013	-0.82	-1.23
2014	-1.43	-1.74
2015	-1.84	-2.23
2016	-3.10	-3.73
2017	-1.01	-1.29
2018	-1.66	-1.99
2019	-0.91	-1.46
2020	-1.09	-1.86

The comparison of the sectoral approach and the reference approach is illustrated in Figure 3.4.1. In 2020, the fuel consumption rates in the two approaches differ by 1.09 % and the CO₂ emission differs by 1.86 %. Both the fuel consumption and the CO₂ emission differ by less than 2 % for all years except 2015 and 2016.

The fluctuations in Figure 3.4.1 follow the fluctuations of the statistical difference in the Danish energy statistics shown in Figure 3.4.2. The large differences in certain years, e.g. in 1998, 2009, 2012, and 2016 are due to high statistical differences in the Danish energy statistics in these years.

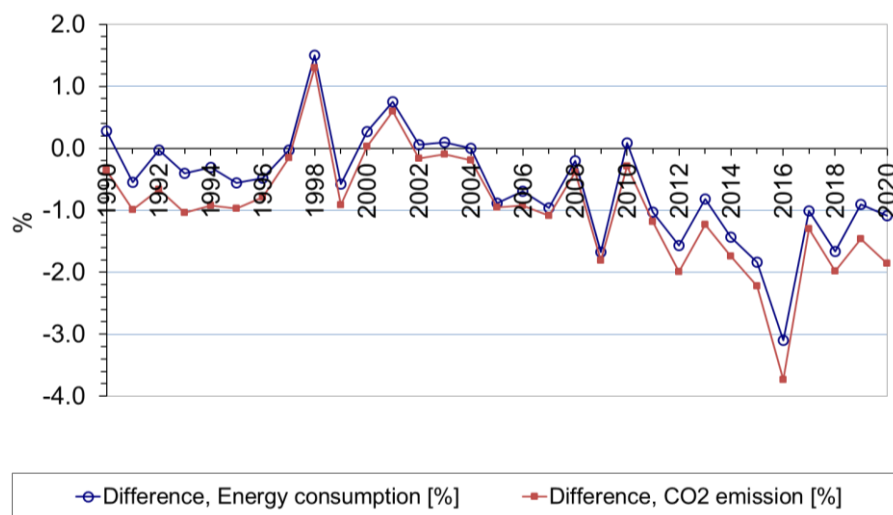

Figure 3.4.1 Comparison of the reference approach and the sectoral approach.

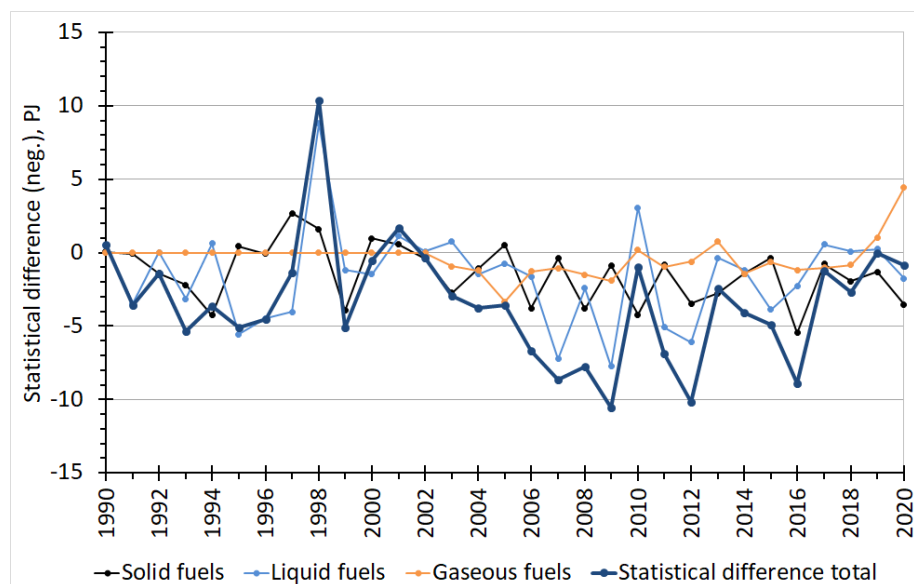

Figure 3.4.2 Statistical difference in the Danish energy statistics (DEA, 2021a).

The difference for both fossil fuel consumption and CO₂-emission between SA and RA is above 2 % for 2016 and the reason for this difference have been further analysed.

The large difference between RA and SA in 2016 is mainly related to fuel consumption data. The fuel consumption applied in the SA was higher than in the RA for all fuel categories for 2016.

Analysis of the differences between the sectoral approach and the reference approach

The difference between the sectoral approach and the reference approach is above 2 % in 2016 and thus the sources causing this difference have been analysed for each of the fossil fuel categories.

Solid fuels

The difference for solid fuels in 2016 is 6.2 % or 5.5 PJ. The statistical difference for solid fuels in the Danish energy statistics is 5.5 PJ for 2016. This difference mainly relates to coal (5.5 PJ). Thus, the difference between approaches is a result of the statistical difference in the energy statistics. A time series for the difference of solid fuel consumption is shown in Figure 3.4.3.

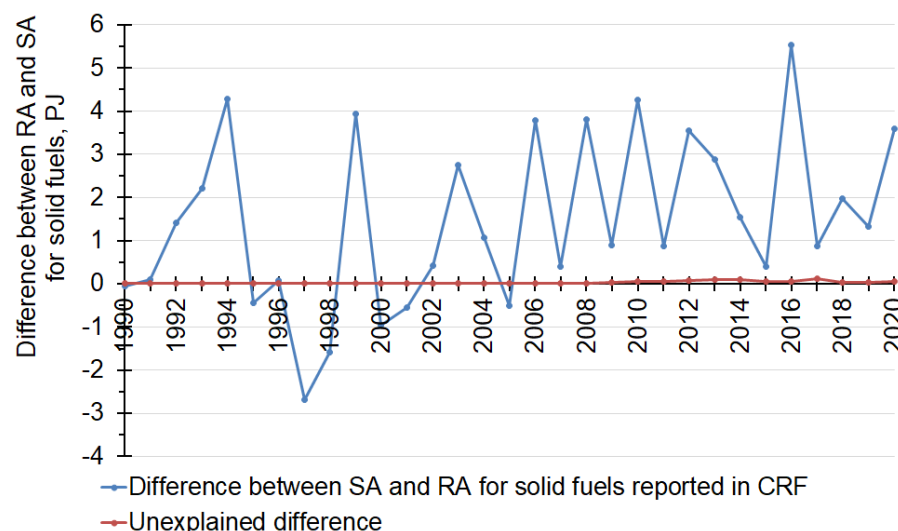

Figure 3.4.3 Difference between RA and SA for solid fuels reported in CRF and the difference not explained by statistical difference of the Danish energy statistics.

Liquid fuels

The difference for liquid fuels in 2016 is 2.4 % or 5.9 PJ. This difference has been further analysed and several sources identified.

- The statistical difference for liquid fuels in the Danish energy statistics is 2.3 PJ for 2016. This difference mainly relates to crude oil (3.7 PJ), motor gasoline (-0.9 PJ) and gas-/diesel oil (-0.8 PJ).
- The Danish energy statistics includes data for net input of blends. In 2016, the net input was 0.2 PJ.
- In the Danish energy statistics, the fuel input to refineries is not equal to the fuel output added to fuel consumption. In 2016, the difference was 2.7 PJ.
- For refinery gas, the fuel consumption applied in the SA is based on EU ETS data rather than the energy statistics (see NIR Chapter 3.2.5). For 2016, the fuel consumption in EU ETS that are applied in SA is 0.7 TJ lower than the data from the energy statistics.

The explained differences for liquid fuels in 2016 add up to 5.4 PJ. Thus, only the remaining 0.5 PJ is not explained. The time series for reported difference for liquid fuels between SA and RA for 1990-2020 is shown in Figure 3.4.4 below. In the figure, the estimated difference taking into account the four known sources explained above is also shown.

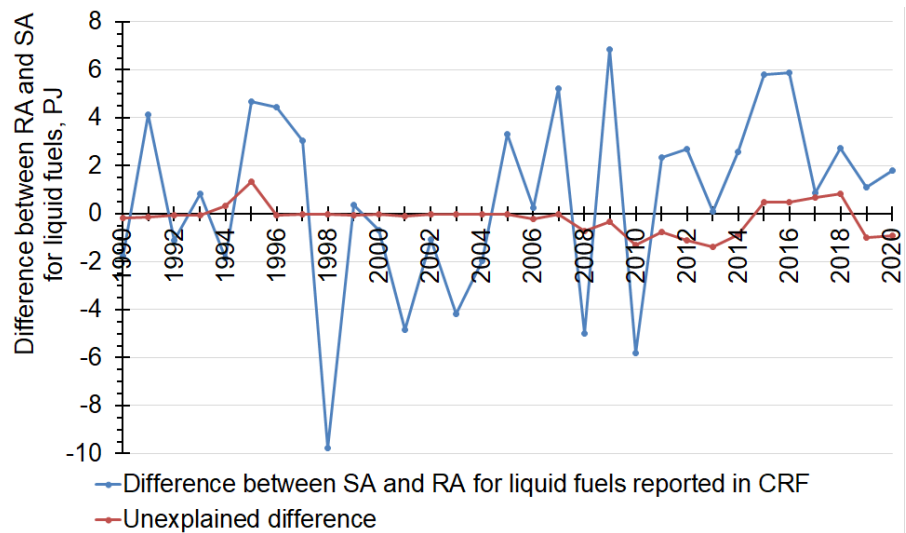

Figure 3.4.4 Difference between RA and SA for liquid fuels reported in CRF and the difference not explained by four known sources.

Gaseous fuels

For 2016, the difference for gaseous fuels is 1.8 % or 2.2 PJ. The statistical difference for gaseous fuels in the Danish energy statistics is 1.2 PJ for 2016. For offshore gas turbines the fuel consumption applied in the sectoral approach is based on EU ETS data rather than the energy statistics (see NIR Chapter 3.2.5). For 2016, the consumption in EU ETS that are applied in SA was 1.0 PJ higher than the data from the energy statistics. The difference between SA and RA for gaseous fuels is shown in Figure 3.4.5 below. The remarkable difference for 2020 is related to a large statistical difference for gaseous fuels in 2020.

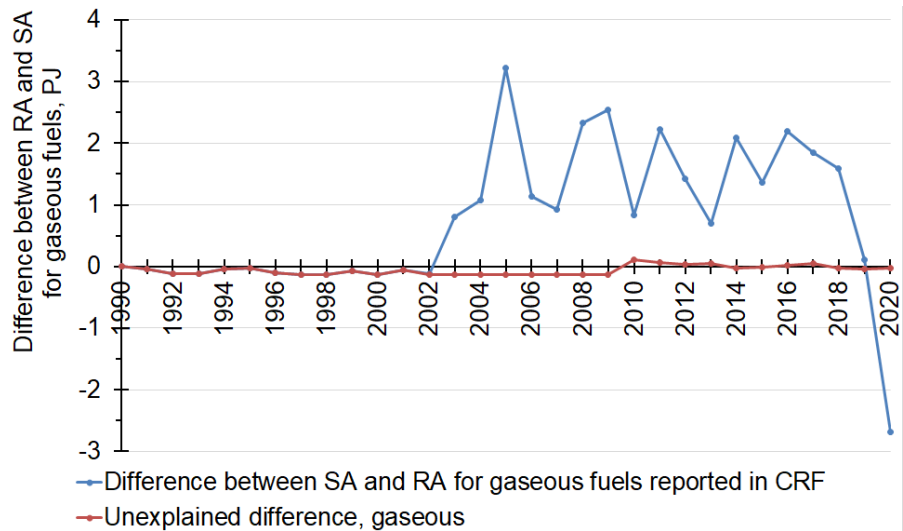

Figure 3.4.5 Difference between RA and SA for gaseous fuels reported in CRF and the difference not explained by three known sources.

Other fossil fuels

For 2016, the difference for other fossil fuels (fossil waste) is 5.8 % or 1.1 PJ.

The statistical difference for fossil waste in the Danish energy statistics is 0.0 PJ for 2016. The fossil part of waste applied in the Danish cement production plant is higher than for other waste applied in Danish incineration plants. The

higher fossil part of the energy content of waste applied in the cement production plant have been implemented in the SA but not in the RA. For 2016, this corresponds to a 0.5 PJ difference. In addition, the combustion of waste in individual plants implemented in the SA for 2016 added up to a higher total than included in the energy statistics. This difference corresponds to a difference of 0.2 PJ fossil waste. Finally, the fossil part of biodiesel reported in SA sector 1A3 is included in the fuel category other fossil fuels. This fuel consumption is included in biomass in RA. In 2016, the fossil part of biodiesel added up to 0.4 PJ.

The higher waste consumption based on the plant specific data than included the energy statistics is related to the applied fuel group for some specific biomass waste fractions. The recent implementation of EU ETS data as a data source for the industrial subsectors has improved transparency and the agreement between the two data sets. Further improvements are expected in future inventories.

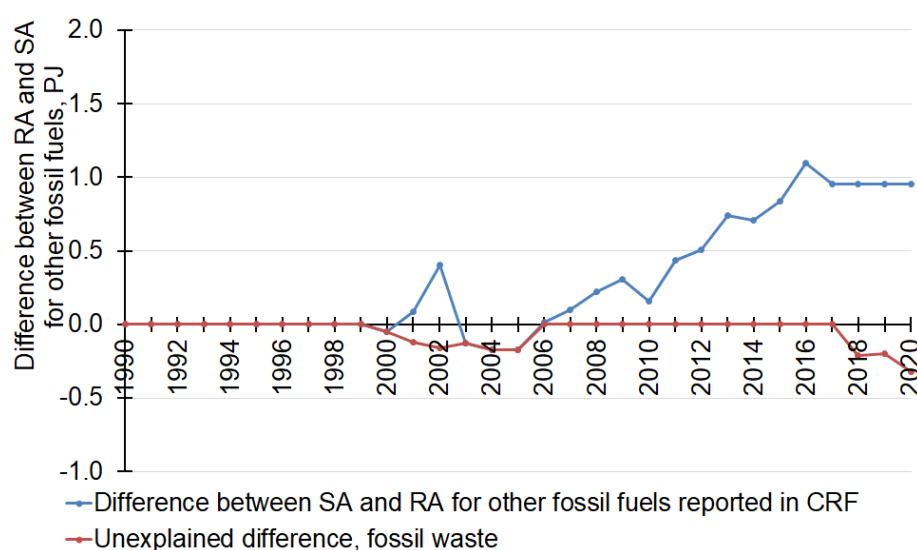

Figure 3.4.6 Difference between RA and SA for other fossil fuels reported in CRF and the difference not explained by four known sources.

Recalculations and improvements

Data for both reference approach and national approach have been updated according to the latest energy statistics.

Response to the review process

One issue is from the review process is relevant for the reference approach. The issue shown below refer to the *Report on the individual review of the annual submission of Denmark submitted in 2020, 15 March 2021*.

Regarding implementation of data for international bunkers in the Reference Approach for Faroe Islands, see NIR Annex 7.

Consistency between CRF tables 1.D and 1.A(b) are now checked for all three CRF reporting;

- Denmark (DNM)
- Denmark and Greenland (DKE)
- Denmark, Greenland and Faroe Islands (DNK)

Table 3.4.2 Response to the review process

E.6	International bunkers and multilateral operations – liquid fuels – CO ₂ (E.7, 2018) Convention reporting adherence	Ensure consistent reporting between CRF tables 1.D and 1.A(b) for jet kerosene consumed in international aviation bunkers (1990–2000) and for residual fuel oil consumed in international navigation bunkers.	Addressing. Denmark ensured consistency in the estimates of jet kerosene consumed in international aviation bunkers (1990–2000) and residual fuel oil consumed in international navigation bunkers between the reference and sectoral approaches in the DNM CRF tables 1.D and 1.A(b). However, the Party did not report the same values of fuel consumed in DNK CRF tables 1.D and 1.A(b). During the review, the Party explained that the differences are due to the Faroe Islands using only the sectoral approach in its reporting and not using the reference approach. Therefore, the fuel consumption estimates for the sectoral approach reported in the DNK CRF tables cover Denmark, Greenland and the Faroe Islands, while those reported for the reference approach cover only Denmark and Greenland.
-----	---	---	---

Planned improvements

The differences mentioned above are part of the ongoing dialogue with the Danish Energy Agency.

3.4.2 References for Chapter 3.4

Danish Energy Agency (DEA), 2021a: The Danish energy statistics, Available at: https://ens.dk/sites/ens.dk/files/Statistik/grunddata2020_-_basicdata2020_0.xlsx (2022-01-11).

IPCC, 2006: Revised 2006 IPCC Guidelines for National Greenhouse Gas Inventories. Available at: <http://www.ipcc-nggip.iges.or.jp/public/2006gl/index.html> (2022-01-11).

3.5 Fugitive emissions (CRF sector 1B)

3.5.1 Overview of sector

Fugitive emissions from fuels include emissions from production, storage, refining, transport, venting and flaring of oil and natural gas. Denmark has no production of solid fuels, and accordingly greenhouse gas emissions from solid fuels are not occurring. The fugitive sector consists of the following CRF categories:

- 1B2a Oil
- 1B2b Natural gas
- 1B2c Venting and flaring

Most fugitive emission sources are of minor importance compared to the total Danish emissions. Fugitive and national total emissions are given in Table 3.5.1. Note that the data presented in Chapter 3 relate to Denmark only, whereas information for Greenland is included in Chapter 16 and for the Faroe Islands in Annex 7.

Table 3.5.1 National and fugitive emissions of CO₂, CH₄, N₂O and GHG in 2020, and the fugitive emissions share of national total emissions.

	National emission kt CO ₂ eqv.	Fugitive emission kt CO ₂ eqv.	Fugitive/national emission %
CO ₂	28 283	126	0.4
CH ₄	7 117	53	0.7
N ₂ O	5 729	21	0.4
GHG	41 510	201	0.5

Table 3.5.2 list the results from the key category analysis for approach 1 and approach 2 for fugitive emission sources.

Table 3.5.2 Key categories in the fugitive emission sector.

CRF table	Pollutant	Key category identification	
		Approach 1	Approach 2
1.B.2.a.1 Exploration, oil	CO ₂	-	-
1.B.2.a.2 Production, oil	CO ₂	-	-
1.B.2.a.4 Refining/storage	CO ₂	-	-
1.B.2.b.1 Exploration, gas	CO ₂	-	-
1.B.2.b.2 Production, gas	CO ₂	-	-
1.B.2.b.4 Transmission and storage, gas	CO ₂	-	-
1.B.2.b.5 Distribution, gas	CO ₂	-	-
1.B.2.c.1.ii Venting, gas	CO ₂	-	-
1.B.2.c.2.i Flaring, oil	CO ₂	-	-
1.B.2.c.2.ii Flaring, gas	CO ₂	-	-
1.B.2.c.2.iii Flaring, combined	CO ₂	Level (1990)	-
1.B.2.a.1 Exploration, oil	CH ₄	-	-
1.B.2.a.2 Production, oil	CH ₄	-	-
1.B.2.a.3 Transport, oil	CH ₄	-	-
1.B.2.a.4 Refining/storage	CH ₄	-	-
1.B.2.b.1 Exploration, gas	CH ₄	-	-
1.B.2.b.2 Production, gas	CH ₄	-	-
1.B.2.b.4 Transmission and storage, gas	CH ₄	-	-
1.B.2.b.5 Distribution, gas	CH ₄	-	-
1.B.2.c.1.ii Venting, gas	CH ₄	-	-
1.B.2.c.2.i Flaring, oil	CH ₄	-	-
1.B.2.c.2.ii Flaring, gas	CH ₄	-	-
1.B.2.c.2.iii Flaring, combined	CH ₄	-	-
1.B.2.a.1 Exploration, oil	N ₂ O	-	-
1.B.2.c.2.i Flaring, oil	N ₂ O	-	-
1.B.2.c.2.ii Flaring, gas	N ₂ O	-	-
1.B.2.c.2.iii Flaring, combined	N ₂ O	-	Level (1990 & 2020), Trend

Calculations of fugitive emissions are to the highest degree possible, based on Tier 2 and Tier 3 methodologies. The methodological Tiers and the level of detail for the applied emission factors in are listed in (Table 3.5.3).

Table 3.5.3 Applied methodology for fugitive emission sources.

CRF	Source	Pollutant	Method	Emission factor
1 B 2 a i	Exploration of oil	CO ₂	Tier 3	PS
		CH ₄	Tier 3	CS
		N ₂ O	Tier 3	D
1 B 2 a ii	Production of oil	CO ₂	Tier 3	D
		CH ₄	Tier 3	D
1 B 2 a iii	Transport	CH ₄	Tier 2	PS, CS, OTH (EMEP/EEA 2019)
1 B 2 a iv	Refining/storage	CO ₂	Tier 3	CS(1990-2005), PS(2006 onwards)
		CH ₄	Tier 3	PS, CS
1 B 2 b i	Exploration of gas	CO ₂	Tier 3	PS
		CH ₄	Tier 3	CS
		N ₂ O	Tier 3	D
1 B 2 b ii	Production of gas, Offshore activities	CO ₂	Tier 3	D
		CH ₄	Tier 3	D
1 B 2 b iv	Transmissions and storage	CO ₂	Tier 2	CS
		CH ₄	Tier 2	CS
1 B 2 b v	Distribution	CO ₂	Tier 2	CS
		CH ₄	Tier 2	CS
1 B 2 c 1 ii	Venting in gas storage	CO ₂	Tier 3	CS(1990-1994), PS(1995 onwards)
		CH ₄	Tier 3	D
1 B 2 c 2 i	Flaring in oil refinery	CO ₂	Tier 3	CS(1990-2006), PS(2007 onwards)
		CH ₄	Tier 3	D
		N ₂ O	Tier 3	D
1 B 2 c 2 ii	Flaring in gas storage, transmission and distribution	CO ₂	Tier 3	CS(1990-2006), PS(2007 onwards)
		CH ₄	Tier 3	D
		N ₂ O	Tier 3	D
1 B 2 c 2 iii	Flaring in oil and gas extraction	CO ₂	Tier 3	CS(1990-2007), PS(2008 onwards)
		CH ₄	Tier 3	CS
		N ₂ O	Tier 3	D

Note: PS: plant specific. CS: country specific, D: default (IPCC, 2006), OTH: other.

3.5.2 Source category description

According to the IPCC sector definitions the category *fugitive emissions from fuels* is a sub-category under the main-category Energy (Sector 1). The category *fugitive emissions from fuels* (Sector 1B) is segmented into sub-categories covering emissions from solid fuels (*coal mining and handling (1B1a), solid fuel transformation (1B1b) and other (1B1c)*), oil (*oil (1B2a)*), natural gas (*1B2b*), venting and flaring (*1B2c*) and other (*1B2d*). The sub-categories relevant for the Danish emission inventory are shortly described below according to Danish conditions:

- 1B1a: Fugitive emission from solid fuels: Coal mining and solid fuel transformation are not occurring in Denmark. Accordingly, greenhouse gas emissions from solid fuels are not occurring in Denmark.
- 1B2a: Fugitive emissions from oil include emissions from exploration, production, storage, and transmission of crude oil, distribution of oil products and fugitive emissions from refining.
- 1B2b: Fugitive emissions from natural gas include emissions from exploration, production, transmission of natural gas and distribution of natural gas and town gas.
- 1B2c: Venting and flaring include activities onshore and offshore. Flaring occur both offshore in upstream oil and gas production, and onshore in gas treatment and storage facilities, in refineries and in natural gas transmission and distribution. Venting occurs in gas storage facilities. Venting of gas is assumed to be negligible in oil and gas production and in refineries as controlled venting enters the gas flare system.

Table 3.5.4 summarizes the Danish fugitive greenhouse gas emissions in 2020. Information on other pollutants are included in the Informative Inventory Reports (IIR) reported annually to UNECE CLRTAP (Nielsen et al., 2022).

Table 3.5.4 Summary of the Danish fugitive emissions 2020. P refers to point source and A to area source.

PCC code	Source	Type*	Pollutant	Emission	Unit	Share of total fugitive
1B2a1	Exploration of oil	A	004	0	t	0%
1B2a1	Exploration of oil	A	006	0	kt	0%
1B2a1	Exploration of oil	A	007	0	t	0%
1B2a2	Production of oil	A	004	3.453	t	0.11%
1B2a2	Production of oil	A	006	<0.001	kt	<0.01%
1B2a3	Offshore loading of oil	A	004	35.880	t	1.16%
1B2a3	Onshore loading of oil	A	004	3.120	t	0.10%
1B2a4	Other	P	006	0.043	kt	0.02%
1B2a4	Petroleum products processing	P	004	538.200	t	17.39%
1B2a4	Storage of crude oil	A	004	247.999	t	8.01%
1B2a4	Storage of crude oil	A	006	0.004	kt	<0.01%
1B2b1	Exploration of gas	A	004	0	t	0%
1B2b1	Exploration of gas	A	006	0	kt	0%
1B2b1	Exploration of gas	A	007	0	t	0%
1B2b2	Production of gas	A	004	1157.100	t	37.38%
1B2b2	Production of gas	A	006	0.043	kt	0.02%
1B2b4	Natural gas transmission	A	004	194.800	t	6.29%
1B2b4	Natural gas transmission	A	006	0.004	kt	<0.01%
1B2b5	Natural gas distribution	A	004	67.689	t	2.19%
1B2b5	Natural gas distribution	A	006	0.002	kt	<0.01%
1B2b5	Town gas distribution	A	004	56.760	t	1.83%
1B2b5	Town gas distribution	A	006	<0.001	kt	<0.01%
1B2c1ii	Venting in gas storage	P	004	28.036	t	0.91%
1B2c1ii	Venting in gas storage	P	006	<0.001	kt	<0.01%
1B2c2i	Flaring in oil refinery	P	004	4.997	t	0.16%
1B2c2i	Flaring in oil refinery	P	006	15.778	kt	8.10%
1B2c2i	Flaring in oil refinery	P	007	0.130	t	0.11%
1B2c2ii	Flaring in gas storage	P	004	0.428	t	0.01%
1B2c2ii	Flaring in gas storage	P	006	1.330	kt	0.68%
1B2c2ii	Flaring in gas storage	P	007	<0.001	t	<0.01%
1B2c2ii	Flaring in gas transmission and distribution	A	004	0.008	t	<0.01%
1B2c2ii	Flaring in gas transmission and distribution	A	006	0.043	kt	0.02%
1B2c2ii	Flaring in gas transmission and distribution	A	007	<0.001	t	<0.01%
1B2c2iii	Flaring in gas and oil extraction	A	004	756.893	t	24.45%
1B2c2iii	Flaring in gas and oil extraction	A	006	177.468	kt	91.14%
1B2c2iii	Flaring in gas and oil extraction	A	007	114.681	t	99.89%

* A: area source, P: point source.

**Regeneration of catalysts

3.5.3 Use of EU ETS data

Reporting to the European Union Emission Trading Scheme (EU ETS) are available in the annual EU ETS reports for refineries, upstream oil and gas extraction facilities and the natural gas treatment plant, concerning fugitive emissions. EU ETS data are only included in the national emission inventory

if higher tier methodologies are applied, which is the case for the EU ETS reports regarding fugitive emission sources. The EU ETS data used are fully in line with the requirements in the IPCC Guidelines and are considered the best data source on CO₂ emission factors due to the legal obligation for the relevant companies to make the accounting following the specified EU decisions. The EU ETS data are thereby a source of consistent data with low uncertainties. For further information on EU ETS, please refer to the section “*Use of EU Emission Trading Scheme data*” in Chapter 1. Unfortunately, corresponding data do not exist before the commencement of EU ETS in 2006 and therefore it is not possible to set up time series based on EU ETS. In these cases, appropriate methods from the IPCC Guidelines have been selected to ensure time series consistency. This is described in the specific sections.

EU ETS reports for refineries

Activity data are measured with flow meters and rates are reported with high accuracy using the Tier 4 methodology (uncertainty $\pm 1.5\%$) for large sources and Tier 3 (uncertainty $\pm 2.5\%$) or Tier 2 (uncertainty $\pm 5\%$) for small sources. The oxidation factor is set to 1, corresponding the Tier 1 methodology. CO₂ emission factors are calculated according to the relevant Tier given in the EU Commission Implementing Regulation of 19 December 2018 (EU Commission, 2018). The Tier 2b methodology based on yearly density and calorific values is applied, while the activity specific Tier 3 methodology is applied for diesel. CO₂ emissions factors for flaring are calculated using the Tier 3 methodology based on the measured carbon contents.

EU ETS reports for offshore installations

Activity data are measured with flow meters and rates are reported with high accuracy. For combustion, the Tier 4 methodology (uncertainty $\pm 1.5\%$) is used for large sources and Tier 3 (uncertainty $\pm 2.5\%$) or Tier 2 (uncertainty $\pm 5\%$) for small sources. For flaring, mainly the Tier 3 or the Tier 2 methodology is used (uncertainty $\pm 7.5\%$ or $\pm 12.5\%$) is used. The oxidation factor is set to 1, corresponding the Tier 1 methodology. CO₂ emission factors are calculated according to the relevant Tier given in the EU Commission Implementing Regulation of 19 December 2018 (EU Commission, 2018). For combustion of fuel gas the Tier 3 methodology, which is activity specific, is applied, while the country specific Tier 3 methodology is applied for diesel. CO₂ emissions factors for flaring are calculated using the Tier 2b methodology.

3.5.4 Activity data, emission factors and emissions for fugitive sources

The following paragraphs describe the methodology for emission calculation for fugitive sources, including activity data, emission factors and annual emissions. The order follow the IPCC structure (1B2a Oil, 1B2b Natural gas, 1B2c Venting and flaring), with the exception that exploration and production of gas are include in the paragraphs for exploration and production of oil, due to similar methodologies and data providers.

Fugitive emissions from oil (1B2a)

The emissions from oil derive from exploration, production, onshore and offshore loading of ships, onshore oil tanks, service stations and refineries. Exploration and production of both oil and gas are described in this paragraph.

Exploration (1B2a1, 1B2b1)

Activity data

Activity data for oil and gas exploration are provided annually by the Danish Energy Agency (Erichsen, 2021). Data for exploration of oil and gas are given separately for each exploration drilling, and fluctuate significantly over the time series. The largest oil rates are seen for 1990, 2002 and 2005, while relatively large gas rates are seen for more years of the time series. There was no exploration activity in 2020. Explored rates are shown in Figure 3.5.1.

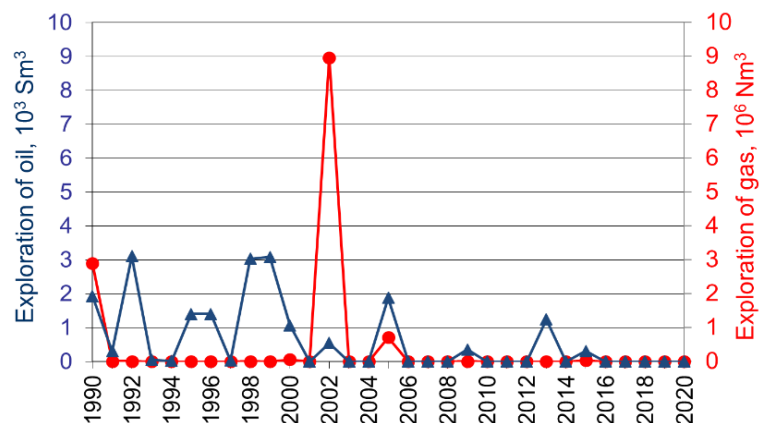

Figure 3.5.1 Exploration of oil and gas.

Emission factors

Annual CO₂ emission factors are based on composition data, calorific values and densities for explored oil and gas provided by the Danish Energy Agency. Composition data are available for the exploration and appraisal wells (E/A wells) separately, except for a few E/A wells, for which the compositions for the previous E/A well are used for emission calculation. As calorific values and densities are not available per drilling, data from a gas test in 1992 are used. CO₂ emission factors are listed in Table 3.5.5. The emission factors used to calculate emissions from offshore flaring in upstream oil and gas production are applied for the remaining pollutants (refer to the Section *Fugitive emissions from venting and flaring (1B2c)* below).

Table 3.5.5 Annual CO₂ emission factors for years with exploration of oil and gas.

	1990	1991	1992	1993	1994	1995	1996	1997
EF(CO ₂), exploration of oil, kg/Sm ³	2433	2437	2439	2441	2437	2449	2449	2449
EF(CO ₂), exploration of gas, kg/Nm ³	2.85	2.82	2.87	2.93	2.82	2.94	2.94	2.94
<i>continued</i>								
	1998	1999	2000	2002	2005	2009	2013	2015
EF(CO ₂), exploration of oil, kg/Sm ³	2445	2449	2449	2441	2444	2449	2449	2449
EF(CO ₂), exploration of gas, kg/Nm ³	2.94	2.94	2.94	2.88	2.89	2.82	2.82	2.82

Emissions

Calculated CH₄ emissions for exploration of oil and gas are shown in Figure 3.5.2. There is no correlation between emissions from oil and gas, as the individual exploration drillings have different ratios between oil and gas rates.

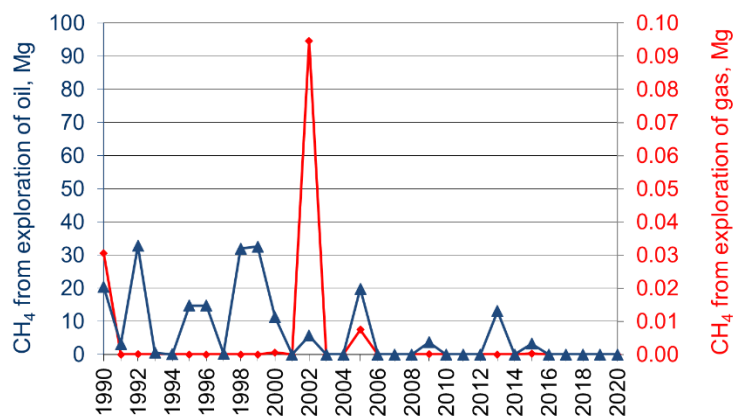

Figure 3.5.2 CH₄ emissions from exploration of oil and gas.

Production (1B2a2, 1B2b2)

Activity data

Activity data used for oil and gas production are provided by the Danish Energy Agency (DEA 2021a). As seen in Figure 3.5.3 the production of oil and gas in the North Sea has generally increased in the years 1990-2004, and since 2004 the production has decreased. Five major platforms were completed in 1997-1999, which is the main reason for the great increase in the oil production in the years 1998-2000.

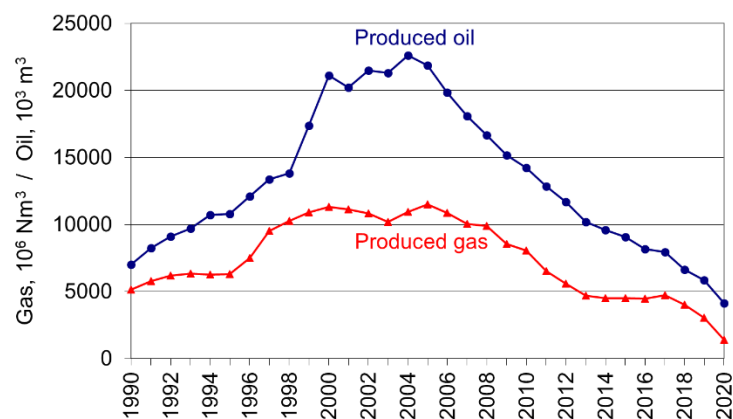

Figure 3.5.3 Production of oil and gas.

Emission factors

Standard emission factors from the 2006 IPCC Guidelines (IPCC, 2006) are used to calculate emissions from production of oil and gas (see Table 3.5.6).

Table 3.5.6 Emission factors for exploration of oil and gas.

	CO ₂	CH ₄	Reference
Production of oil, kt/1000m ³	4.30E-08	5.90E-07	IPCC 2006
Production of gas, kt/Mm ³	1.40E-05	3.80E-04	IPCC 2006

Emissions

Calculated CH₄ emissions from oil and gas production are shown in Figure 3.5.4. The annual variations follow the production rates.

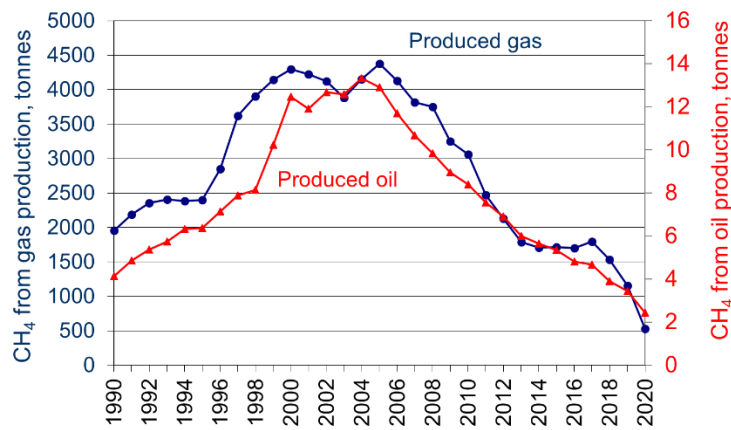

Figure 3.5.4 CH₄ emissions from production of oil and gas.

Transport (1B2a3)

Activity data

Fugitive emissions of oil transport include loading of ships from storage tanks or directly from the wells. Activity data for loading offshore and onshore are provided by the Danish Energy Agency (DEA 2021a) and from the annual self-regulating reports and supplementing data from Danish Oil Pipe A/S (Boesen, 2021), respectively.

The rates of oil loaded on ships roughly follow the trend of the oil production (see Figure 3.5.5). Offshore loading of ships was introduced in 1999. In earlier years, the produced oil was transported to land via pipeline.

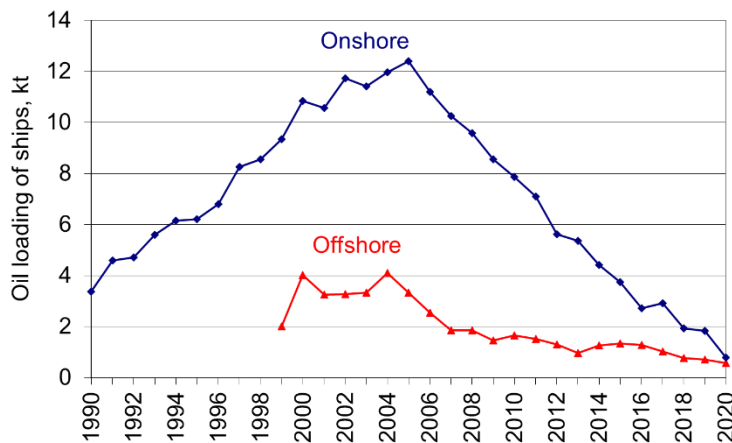

Figure 3.5.5 Onshore and offshore loading of ships.

Emission factors

Emissions from storage tanks at the Oil terminal are provided annually by Danish Oil Pipe A/S. During 2009 new emission reducing technologies (de-gassing unit) were installed at the crude oil terminal, leading to a significant decrease of the emissions as shown in Figure 3.5.6.

The EMEP/EEA Guidebook provide standard emission factors for loading of ships offshore for different countries (EMEP/EEA, 2019). In the Danish inventory, the Norwegian emission factors are used for estimation of fugitive emissions from loading of ships offshore for the years 1990-2009.

Emission factors for onshore loading is based on annual reports from the Shell Harbour Terminal for the years 2012 onwards (A/S Dansk Shell - Havnerterminalen, 2013, 2014, 2015, 2016, 2017, 2018, 2019, 2020, 2021), which include

loaded amounts, standard NMVOC emission factors and emissions of NMVOC (2013-2017) or VOC (2019-2020). Estimation of CH₄ emission factors are based on the assumption that NMVOC make up 80% of VOC in accordance with the annual reports for the harbour terminal.

The emission factor for 2012 is applied for the earlier years in the time series. The emission factors show a significant decrease from 2016 due to installation of a new vapour recovery unit (VRU2) during 2017. No emissions were reported for 2018, but have been estimated according to the environmental approval for VRU2 (Danish EPA, 2017) which include a requirement of 85 % emission reduction of the VRU2.

Emission factors for loading of ships offshore and onshore are listed in Table 3.5.7.

Table 3.5.7 Emission factors for the oil terminal and for onshore and offshore loading of ships.

Source	Pollutant	Unit	Emission factor
Oil terminal	CO ₂	kt/1000m ³ oil transported by pipeline	4.9E-07
Offshore loading of ships	CH ₄	fraction of loaded	5E-05
Offshore loading of ships, 1990-2012	CH ₄	g/ton	146
Ships onshore, 2013	CH ₄	g/ton	147
Ships onshore, 2014-2016	CH ₄	g/ton	146
Ships onshore, 2017	CH ₄	g/ton	84
Ships onshore, 2018	CH ₄	g/ton	22
Ships onshore, 2019	CH ₄	g/ton	1.7
Ships onshore, 2020	CH ₄	g/ton	2.1

Emissions

CH₄ emissions from transport of oil are shown in Figure 3.5.6.

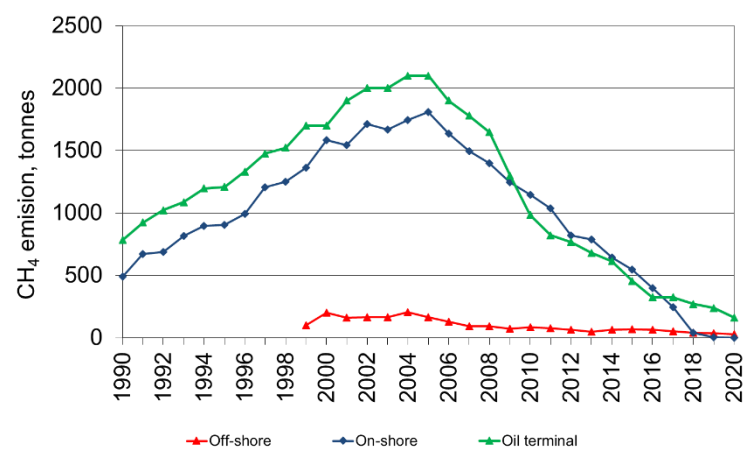

Figure 3.5.6 CH₄ emissions from storage at the raw oil terminal and from onshore and offshore loading of ships.

Refining/storage (1B2a4)

Activity data

Refining/storage include emissions from storage and handling at the oil terminal and emissions from oil refinery processes, including non-combustion emissions from handling and storage of feedstock (raw oil), from the petroleum product processing, from handling and storage of products, and from regeneration of catalysts. Emissions from flaring in refineries are included in

the Section *Fugitive emissions from venting and flaring (1B2c)*. Emissions related to process furnaces in refineries are included in stationary combustion.

Annual emissions from storage and handling at the oil terminal is provided in the annual self-regulating reports and supplementing data from Danish Oil Pipe A/S (Boesen, 2021).

Rates of crude oil processed in the two Danish refineries are given in their annual environmental report (A/S Dansk Shell, 2021 and Equinor Refining Denmark A/S, 2021). Until 1996 a third refinery was in operation, leading to a decrease in the crude oil rate from 1996 to 1997. Activity data are shown in Figure 3.5.7.

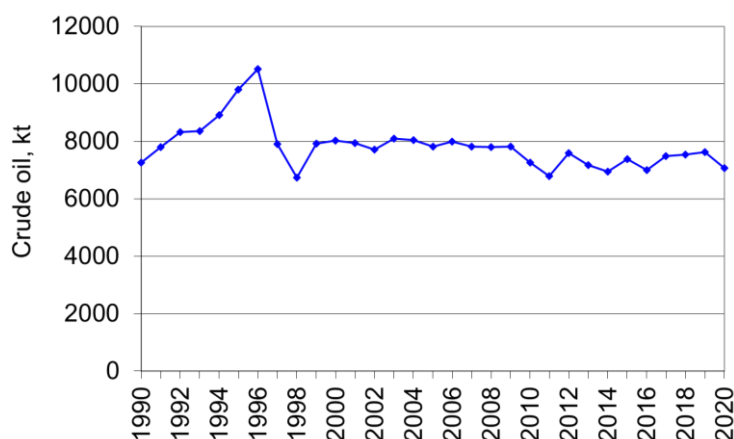

Figure 3.5.7 Crude oil processed in Danish refineries.

Emission factors

The standard CO₂ emission factor for oil transport from the 2006 IPCC Guidelines (IPCC, 2006) is used to calculate emissions from storage and handling at the oil terminal (Table 3.5.7).

VOC emissions are provided by the refineries. Only one of the two refineries has made a split between NMVOC and CH₄. For the other refinery, it is assumed that 10 % of the VOC emission is CH₄ (Hjerrild & Rasmussen, 2014).

Both the non-combustion processes including product processing and sulphur recovery plants emit SO₂. For descriptions regarding fugitive emissions of SO₂ and other pollutants from refining, please refer to the Danish Informative Inventory Report (Nielsen et al., 2022).

Emissions

CH₄ emissions from storage at the raw oil terminal is shown in Figure 3.5.6.

Annual plant specific CO₂ emission from regeneration of catalysts are available in the EU ETS reporting from 2006 onwards. For years prior to 2006, the CO₂ emissions from regeneration of catalysts are based on 1) emissions given in the annual environmental reports, 2) the average emission factor for years with both activity data and emission in the EU ETS reporting (2.515 t CO₂ / t coke) for years where activity data, or 3) the average emission for the first five years with data.

Figure 3.5.8 shows CH₄ emissions from the Danish refineries for selected years in the time series. The increase from 2005 to 2006 owes a new measurement campaign at one refinery, which showed larger emissions than the previous.

According to the environmental department at the refinery, fugitive emissions from oil processing in refineries are not correlated to any measured parameters, but are expected to follow a more random pattern. The refinery has chosen to report the latest measured emission for the years between measurement campaigns, and as no better methodology are available, the same approach is used in the national emission inventories.

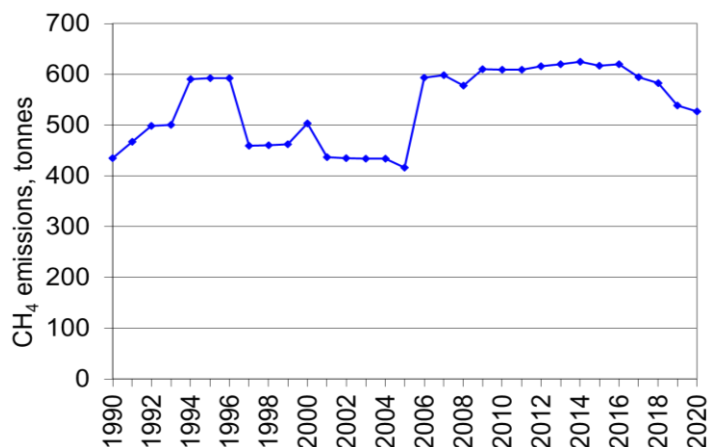

Figure 3.5.8 CH₄ emissions from crude oil processing in Danish refineries.

Service stations (1B2a5)

Fugitive emissions from service stations cover only NMVOC. For a description on methodology and data basis, please refer to the Danish Informative Inventory Report (Nielsen et al., 2022).

Fugitive emissions from natural gas (1B2b)

The emissions from natural gas derive from exploration, transmission, storage and distribution. Descriptions of exploration and production of natural gas are included in the sections covering exploration and production of oil *Exploration (1B2a1, 1B2b1)* and *Production (1B2a2, 1B2b2)*.

Exploration (1B2b1)

See Section *Exploration (1B2a1, 1B2b1)*.

Production (1B2b2)

See Section *Production (1B2a2, 1B2b2)*.

Transmission and storage (1B2b4)

Activity data

The fugitive emissions from transmission and storage of natural gas are based on information from the gas transmission companies, which provide data on transported rate, pipeline losses, and length and material of the pipeline systems. The length of the transmission pipelines is approximately 900 km.

The activity data used in the calculation of the emissions from transmission of natural gas are shown in Figure 3.5.9. Transmission rates for 1990-1998 refer to annual environmental reports of DONG Energy. In 1999-2006, transmission rates refer to the Danish Gas Technology Centre (Karll 2002, Karll 2003, Karll 2004, Karll 2005, Oertenblad 2006, Oertenblad 2007). From 2008 onwards, transmission rates refer to Energinet.dk (2021b). Transmission losses for 1991-1999 are based on annual environmental report of DONG Energy. The average for 1991-1995 is applied for 1990. From 2005 onwards, transmission losses are given by Energinet.dk. The average for 2005-2010 is applied for the years 2000-2004.

The variation over the time series owes mainly to variations in the winter temperature and to the variation of import/export of electricity from Norway and Sweden. The transmission rate is less than the production rate, as part of the produced natural gas is exported through the NOGAT pipeline system.

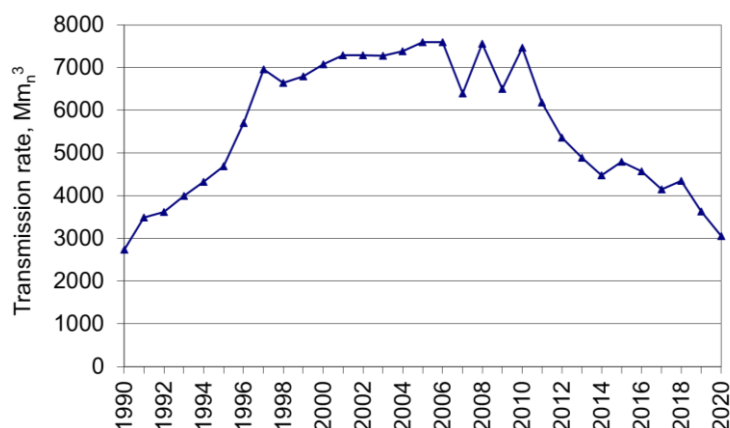

Figure 3.5.9 Rates for transmission of natural gas.

Emission factors

The fugitive emissions from transmission and storage of natural gas are based on data on gas losses from the companies and on the average annual natural gas composition given by Energinet.dk (2021c) (Table 3.5.8).

Table 3.5.8 Annual gas composition, lower heating value and density for Danish natural gas.

	Unit	1990	2000	2005	2010	2015	2019	2020
Methane	CH ₄ molar-%	90.92	86.97	88.97	89.95	88.80	91.2	95.9
Ethane	C ₂ H ₆ molar-%	5.08	6.88	6.14	5.71	6.08	5.01	3.05
Propane	C ₃ H ₈ molar-%	1.89	3.17	2.50	2.19	2.47	1.75	0.18
i-Butane	i-C ₄ H ₁₀ molar-%	0.36	0.43	0.40	0.37	0.39	0.31	0.05
n-Butane	n-C ₄ H ₁₀ molar-%	0.50	0.61	0.55	0.54	0.59	0.46	0.03
i-Petane	i-C ₅ H ₁₂ molar-%	0.14	0.11	0.11	0.13	0.13	0.11	0.01
n-Petane	n-C ₅ H ₁₂ molar-%	0.10	0.08	0.08	0.08	0.10	0.07	0.01
n-Hexane and heavier hydrocarbons	C ⁶⁺ molar-%	0.09	0.06	0.05	0.06	0.05	0.05	0.02
Nitrogen	N ₂ molar-%	0.31	0.34	0.29	0.31	0.32	0.29	0.31
Carbon dioxide	CO ₂ molar-%	0.60	1.35	0.90	0.66	1.07	0.76	0.44
Lower heating value	H _n MJ/m ³ _n	39.176	40.154	39.671	39.461	39.635	38.812	36.700
Density	ρ kg/m ³ _n	0.808	0.846	0.825	0.816	0.828	0.803	0.749

Emissions

The gas transmission company reports emissions of CH₄ for the years 1999 and onwards, based on registered loss in the transmission grid and the emission from the natural gas consumption in the pressure regulating stations. For the years 1991-1998, the CH₄ emissions for transmission are estimated based on the registered loss provided by the transmission company and the annual composition of Danish natural gas given by Energinet.dk. Transmission loss is not available for 1990, why the average for 1991-1995 is applied.

As the pipelines in Denmark are relatively new and made of plastic, most emissions are due to leaks during construction and maintenance. This leads to large annual fluctuations in emissions, which are not correlated to the transmission rates. E.g. the large emission in 1995 owe to a large construction work covering four different locations. The increase in 2011 owe to venting for

drainage of the pipes in preparation for construction work on a new compressor station, and the increase in 2014 owe to the construction of a new major railway line.

Emissions of CH₄ from transmission of natural gas are shown in Figure 3.5.10. Emissions of CO₂ from transmission and storage are very limited and not included in the figure. For information on emissions of NMVOC, please refer to Chapter 3.4 in the Danish Informative Inventory Report (Nielsen et al., 2022).

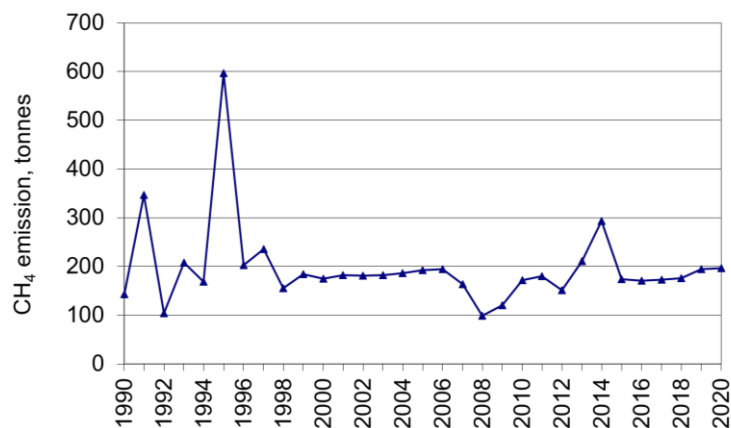

Figure 3.5.10 CH₄ emissions from transmission of natural gas.

Distribution (1B2b5)

Activity data

Distribution rates for 1990-1998 are estimated from the Danish energy statistics. Distribution rates are assumed to equal total Danish consumption rate minus the consumption rates of sectors that receive the gas at high pressure. The following consumers are assumed to receive high-pressure gas: town gas production companies, production platforms and power plants. In 1999-2006, distribution rates refer to DONG Energy/Danish Gas Technology Centre/Danish gas distribution companies (Karll, 2002; Karll, 2003; Karll, 2004; Karll, 2005; Oertenblad, 2006; Oertenblad, 2007). Since 2007, the distribution rates are given by the companies. The fugitive losses from distribution of natural gas are only given for some companies. The average of the available “loss/distribution”-ratios is used for the remaining companies too.

Activity data for distribution of town gas are rather scarce, and calculations are based on the available data from the town gas distribution companies on losses from the pipelines. At present, there are two areas with town gas distribution and correspondingly two distribution companies. Two other companies in other areas were closed in 2004 and 2006, and it has not been possible to collect data for all years in the time series. The emissions have been calculated for the years with available data and the distribution loss for the first year with data has been applied for the previous years in the time series. Data is missing for the later years (1996-2003) for one of the distribution companies. The distribution rate is assumed to decrease linearly to zero over these years, and the share (“distribution loss/distribution rate”) is assumed equal to the value for 1995.

Data on the distribution network are given by Energinet.dk, DGC and the distribution companies concerning length and material. The length of the distribution network is around 20.000 km. Because the distribution network in Denmark is relatively new, most of the pipelines are made of plastic (approximately 90 %). For this reason, the fugitive emission is negligible under normal

operating conditions as the distribution system is basically tight with no fugitive losses. However, the plastic pipes are vulnerable and therefore most of the fugitive emissions from the pipes are caused by losses due to excavation damages, and construction and maintenance activities performed by the gas companies. These losses are either measured or estimated by calculation in each case by the gas companies. About 5 % of the distribution network is used for town gas. This part of the network is older and the fugitive losses are larger. The fugitive losses from this network are associated with more uncertainty as it is estimated as a percentage (15 %) of the meter differential. This assumption is based on expert judgement from one of the town gas companies (Jensen, 2008). Distribution rates are shown in Figure 3.5.11.

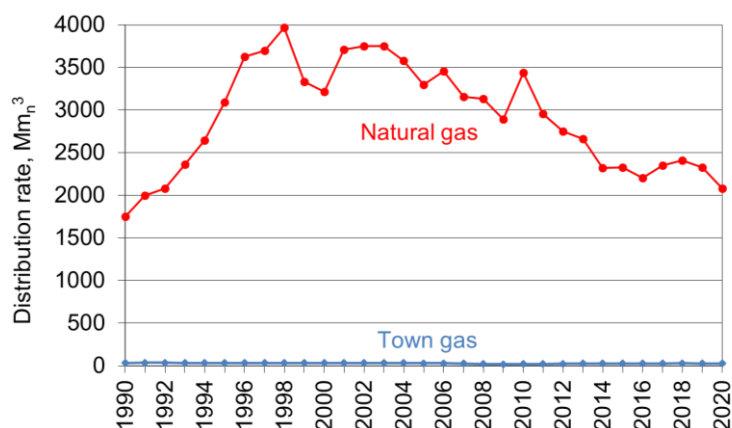

Figure 3.5.11 Distribution rates of natural gas and town gas.

Emission factors

Emissions from natural gas distribution are calculated from the fugitive losses from pipelines and the gas quality measured by Energinet.dk (see Table 3.5.8). The same approach is used for town gas, which is natural gas admixed ~ 50 % ambient air. From 2014, one town gas distribution company has started to admix biogas. In 2014, the share of biogas is 10.1 %, which is expected to increase in the coming years. The admixed biogas has not been upgraded as tests of different appliances have shown that up to 40 % non-upgraded biogas can be added to the town gas without causing problems with the appliances' combustion. The composition of biogas is given in Table 3.5.9.

Table 3.5.9 Composition of biogas admixed to town gas (Jeppesen, 2014; Ea Energianalyse, 2014).

Methane	CH ₄	molar-%	60.98
Nitrogen	N ₂	molar-%	0.001
Carbon dioxide	CO ₂	molar-%	39.02
Lower heating value	H _n	MJ/m ³ _n	21.53
Density	ρ	kg/m ³ _n	0.808

The distribution companies provide emissions of CH₄ for 1997 and onwards. For the years 1995-1996, CH₄ emissions are calculated from the registered loss from distribution and the annual composition of Danish natural gas given by Energinet.dk. As distribution losses are not available for the years 1990-1994, the percentage loss for 1995 is used.

Emissions

Emissions of CH₄ from distribution of natural gas and town gas are shown in Figure 3.5.12. Emissions of CO₂ are very limited and not included in the figure. For information on emissions of NMVOC, please refer to Chapter 3.4 in the Danish Informative Inventory Report (Nielsen et al., 2022).

Emissions from the natural gas network are variable and are associated with renovation to the network and excavation damages.

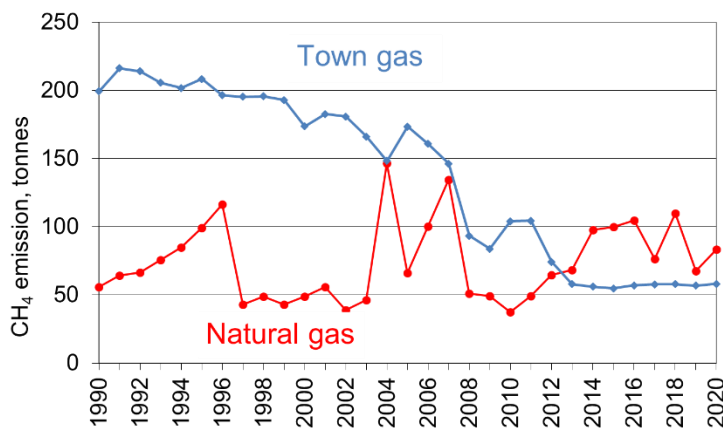

Figure 3.5.12 CH₄ emissions from transmission of natural gas.

Fugitive emissions from venting and flaring (1B2c)

Venting occur in the two Danish natural gas storage facilities. Flaring occurs in oil and gas production, in gas treatment and storage facilities, in refineries, and in gas transmission and distribution.

Venting

Activity data

The natural gas storage facilities are obligated to make environmental reports on an annual basis, including data on venting. Venting of gas is assumed to be not occurring in extraction and in refineries, as controlled venting enters the gas flare system. Venting rates in gas storage facilities are shown in Figure 3.4.13. Data are not available for the years 1990-1994 for the one gas storage facility that was in operation over the entire time series, and the average for 1995-1998 is applied. The second gas storage facility was opened in 1994, leading to increasing venting rates.

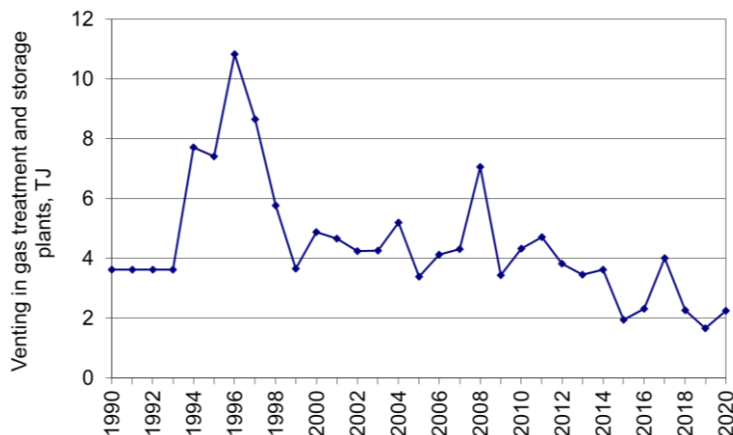

Figure 3.5.13 Venting rates in gas storage facilities.

Emission factors

Emissions of CH₄ and NMVOC from venting are given in the environmental reports for the gas storage facilities (Energinet.dk, 2021a). CO₂ emissions from venting are calculated from country specific emission factors based on annual natural gas composition published by Energinet.dk.

Emissions

Venting is limited to the gas storage facilities and the emissions are of minor importance to the total fugitive emissions. Venting emissions are included in Figure 3.5.14.

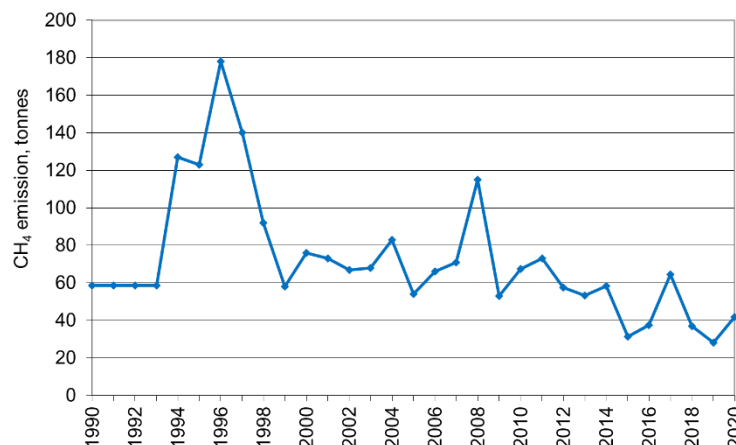

Figure 3.5.14 CH₄ emissions from venting.

Flaring

Flaring in refineries

Activity data

Flaring rates for the two Danish refineries are given in their environmental reports and in additional data provided by the refineries directly to DCE. From 2006, flaring rates are given in the EU ETS reporting. Data are not available for the years 1990-1993, why the flaring rate for 1994 has been adopted for the previous years. Flaring rates are shown in Figure 3.5.15.

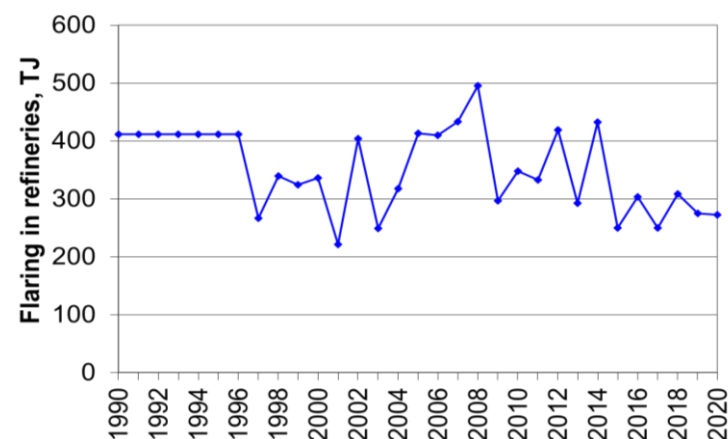

Figure 3.5.15 Flaring rates in refineries.

Emission factors

The composition of refinery gas is given for 2008 by one of the two refineries. As the composition for refinery gas is very different from the composition of natural gas, the 2008 refinery gas composition is used in calculations for both Danish refineries. The CH₄ and NMVOC emission factors based on the 2008 refinery gas composition are applied for both refineries for the entire time series. The CO₂ emission factor is based on the refineries reporting to the EU

ETS from the years 2006 and onwards. Before 2006, corresponding data are not available, and the average of CO₂ emission factors for 2007-2011 for each refinery is applied. The emission factor applied for N₂O is based on OLF (1993) for flaring in oil and gas extraction, as no value are given for flaring in refineries. The emission factors are listed in Table 3.5.10. For information on emissions of other pollutants, please refer to Chapter 3.4 in the Danish Informative Inventory Report (Nielsen et al., 2022).

Table 3.5.10 Emission factors for flaring in refineries for 2020.

Pollutant	Emission factor	Unit
CH ₄	18.1	g per GJ
CO ₂ *	57.53 / 57.44	kg per GJ
N ₂ O	0.47	g per GJ

** The CO₂ emission factors are based on the refineries reports for EU ETS and are plant specific.

Emissions

Emissions of CH₄ and CO₂ are shown in Figure 3.5.16. The variation over the time series follow the flaring rates, with small variations for CO₂ from 2006 onwards, when annual plant specific CO₂ emission factors became available in EU ETS reporting.

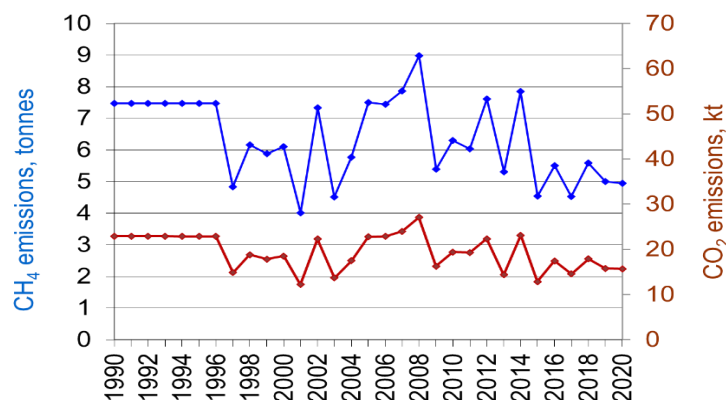

Figure 3.5.16 CH₄ and CO₂ emissions from flaring in refineries.

Flaring in upstream oil and gas production

Activity data

From 2006, data on flaring in upstream oil and gas production is given in the reports submitted under the EU ETS and thereby emission calculation can be made for the individual production units. Before 2006 only the total flared amount is available in the annual report Denmark's oil and gas production (Danish Energy Agency, 2021a). Flaring rates (and CO₂ emissions) are shown in Figure 3.5.17. Flaring rates in upstream oil and gas production have been decreasing over the last 10 years period in accordance with the decrease in production as seen in Figure 3.5.3. Further, there is focus on reducing the amount being flared for environmental reasons.

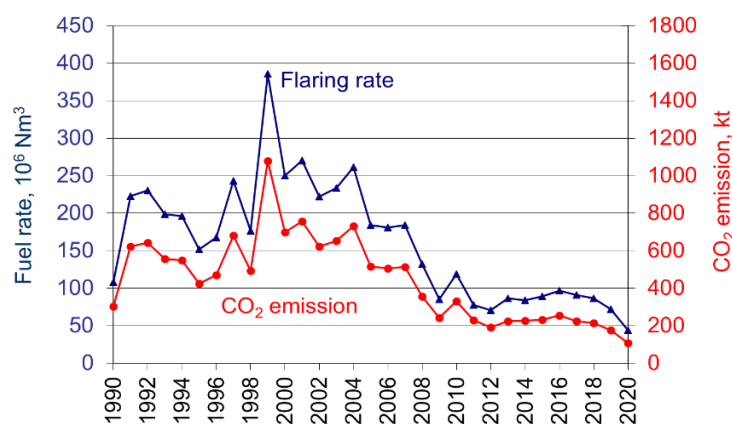

Figure 3.5.17 Fuel rate and CO₂ emission from flaring in upstream oil and gas production.

Emission factors

The emission factors for flaring in upstream oil and gas production are shown in Table 3.5.11. Since 2006, the CO₂ emission factor is calculated according to the reporting for EU ETS. As corresponding data are not available for earlier years, the average CO₂ EF for the years 2008-2012 is applied for the years 1990-2007. The emission factor for CH₄ is estimated from flare gas quality data for one offshore production platform, assuming a flare efficiency of 98 % in agreement with IPCC (2006) and API (2009). Emission factors for N₂O are based on IPCC (2006). For information on emissions of other pollutants, please refer to Chapter 3.4 in the Danish Informative Inventory Report (Nielsen et al., 2022).

Table 3.5.11 Emission factors for flaring in upstream oil and gas production for 2020.

Pollutant	Emission factor	Unit
CH ₄	10.56	g per Nm ³
CO ₂	2.46	kg per Nm ³
N ₂ O	1.6	g per Nm ³

Emissions

The time series for the emission of CO₂ from flaring in upstream oil and gas production fluctuates due to the fluctuations in the fuel rate and to a minor degree due to the CO₂ emission factor. As shown in Figure 3.5.18, there was a marked increase in the rate of flaring in upstream oil and gas production in 1997 and especially in 1999. The increase in 1997 was due to the new Dan field and the completion of the Harald field. The increase in 1999 was due to the opening of the three new fields Halfdan, Siri and Syd Arne. The CH₄ and N₂O emissions from flaring in upstream oil and gas production are estimated from the same emission factors for all years and the variations reflect only the variations in the flared amounts. Emissions of CH₄ from flaring are shown in Figure 3.5.18.

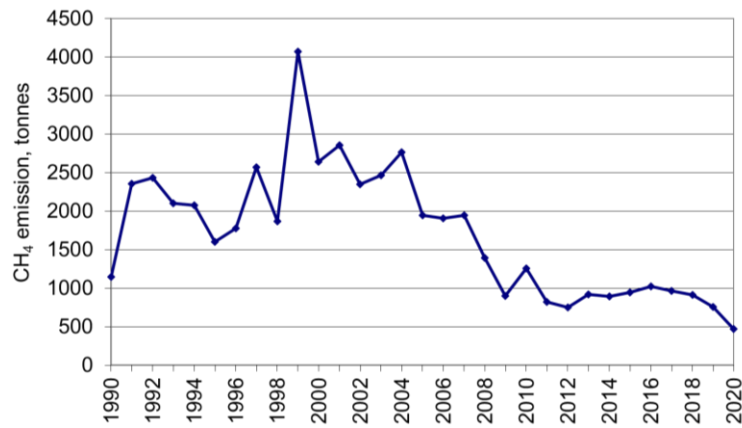

Figure 3.5.18 CH₄ emissions from flaring in upstream oil and gas production.

Flaring in gas treatment and storage facilities

Activity data

Activity data for flaring at the gas treatment facility are given in environmental reports (1994-2005) and in the EU-ETS reports (2006 onwards) and for gas storage facilities in environmental reports (Energinet.dk, 2021a). Flaring rates in gas treatment and gas storage facilities are not available before 1994. The mean value for 1994-1998 has been adopted as basis for the emission calculation for the years 1990-1993 (Figure 3.5.19). Note that one of the two gas storage facilities was not opened before 1994. The large amount of gas flared in 2007 owe to a larger maintenance work at the gas treatment plant.

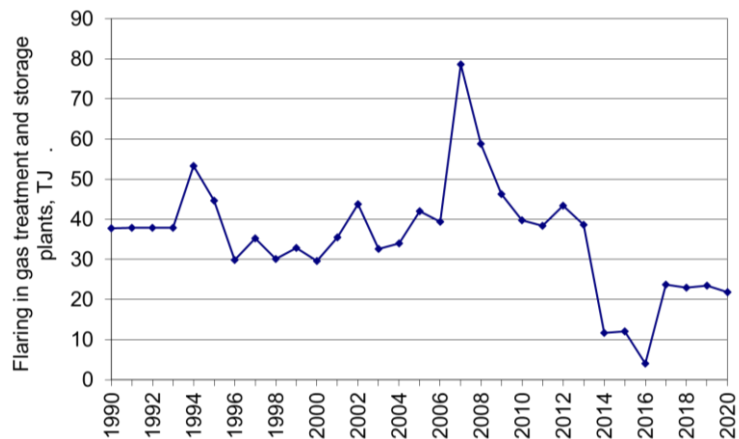

Figure 3.5.19 Flaring in gas treatment and storage facilities.

Emission factors

Emissions from flaring in gas treatment and storage facilities are calculated from the same emission factors, which are used for flaring in upstream oil and gas production, except for CO₂. The natural gas flared in the treatment and storage facilities are natural gas with the same composition as natural gas distributed in Denmark, and the CO₂ emission factors are based on the gas composition given by Energinet.dk.

Emissions

Emissions from flaring in gas treatment and storage facilities are of minor importance to the total fugitive emissions. Emissions from gas treatment and storage facilities have decreased from 2009 to 2010 due to a change from continuous to regulating power operation of the power producing gas turbine at the gas storage plant. CH₄ emissions are included in Figure 3.5.20. The increase in 2017 owe to increased flaring amount at the gas treatment plant.

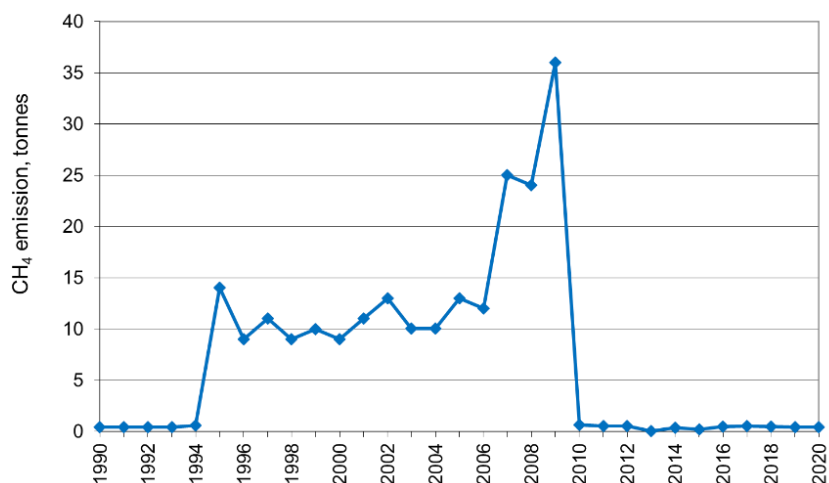

Figure 3.5.20 CH₄ emissions from flaring in gas treatment and storage facilities.

Flaring in gas transmission and distribution

Activity data

Flaring in gas transmission only occurred in the years 2011-2013. Flaring rates are provided by the gas transmission company Energinet.dk.

Flaring in gas distribution was introduced in 2011 and the relevant gas distribution company has provided activity data for the years 2011-2016. Data are not available for the years 2017-2020 due to more rounds of consolidations of the distribution companies, ending up with one single gas distribution company (Evida) since October 2019.

Emission factors

The same emission factors are used for flaring in gas transmission and distribution as for flaring in gas treatment and storage facilities, and the description can be found in the relevant section above.

Emissions

Only minor emissions occur from flaring in gas transmission and distribution and only since 2011. CH₄ emissions are included in Figure 3.5.21.

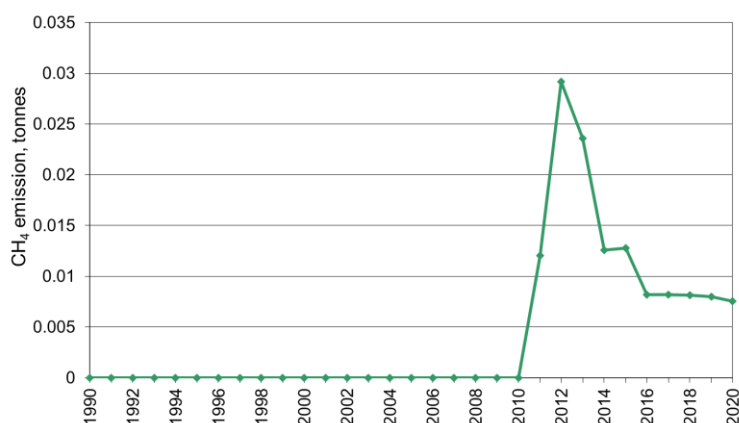

Figure 3.5.21 CH₄ emissions from flaring in gas transmission and distribution.

3.5.5 Uncertainties and time series consistency

Until 2016, two sets of uncertainty estimates were made for the Danish emission inventory for greenhouse gases based on Approach 1 and Approach 2,

respectively. The uncertainty models follow the methodology in the 2006 IPCC Guidelines (IPCC, 2006). Approach 1 is based on the simplified uncertainty analysis (error propagation method) and Approach 2 is based on Monte Carlo simulations. From the 2017 submission, the Approach 2 uncertainty estimation has not been carried out due to a lack of resources.

Uncertainty estimates are made for total emissions in the latest inventory year and for the emission trend for the corresponding time series. Uncertainty estimates are made for the CO₂, CH₄ and N₂O separately and summarized.

Input data

The Approach 1 uncertainty model is based on emission data, uncertainty levels for activity data and uncertainty levels for emission factors for base year and latest inventory year. Emission data, activity data and emission factors are described in Section 3.5.4 *Activity data, emission factors and emissions for fugitive sources*.

The uncertainty levels used in the uncertainty models are based on different sources, e.g. the 2006 IPCC Guidelines, EMEP/EEA Guidebook and reports under the EU ETS. Further, a number of the uncertainty levels are given as DCE assumptions. DCE assumptions are based on source and/or plant specific uncertainty levels for part of the SNAP category and assumptions for the remaining sources and/or plants in the category.

Input data are aggregated on SNAP level. Estimates are made for the greenhouse gases CO₂, CH₄ and N₂O, both separately and summarized (GHG). Uncertainty levels for activity data and emission factors are listed in Table 3.5.12. Uncertainty levels are given in percentage related.

Table 3.5.12 Uncertainty levels for activity rates and emission factors.

Pollutant	CRF category	Source	Activity data	Emission factor
			uncertainty level, %	uncertainty level, %
CO ₂	1.B.2.a.1	Exploration	2 A	10 A
CO ₂	1.B.2.a.2	Production	2 A	100 I
CO ₂	1.B.2.a.4	Refining/storage	2 A	40 S
CO ₂	1.B.2.b.1	Exploration	2 A	10 A
CO ₂	1.B.2.b.2	Production	2 A	100 I
CO ₂	1.B.2.b.4	Transmission and storage	15 G	2 Q
CO ₂	1.B.2.b.5	Distribution	25 G, A	10 Q, A
CO ₂	1.B.2.c.1.ii	Venting	15 G, A	2 Q
CO ₂	1.B.2.c.2.i	Flaring, oil	11 E	2 E
CO ₂	1.B.2.c.2.ii	Flaring, gas	7.5 E	2 E
CO ₂	1.B.2.c.2.iii	Flaring, combined	7.5 E	2 E
CH ₄	1.B.2.a.1	Exploration	2 A	125 A
CH ₄	1.B.2.a.2	Production	2 A	100 I
CH ₄	1.B.2.a.3	Transport	2 A	100 I
CH ₄	1.B.2.a.4	Refining/storage	1 E, A	200 A
CH ₄	1.B.2.b.1	Exploration	2 A	125 A
CH ₄	1.B.2.b.2	Production	2 A	100 I
CH ₄	1.B.2.b.4	Transmission and storage	15 G	2 Q
CH ₄	1.B.2.b.5	Distribution	25 G, A	10 Q, A
CH ₄	1.B.2.c.1.ii	Venting	15 G, A	2 Q
CH ₄	1.B.2.c.2.i	Flaring, oil	11 E	15 H, A
CH ₄	1.B.2.c.2.ii	Flaring, gas	7.5 E	2 A
CH ₄	1.B.2.c.2.iii	Flaring, combined	7.5 E	125 I
N ₂ O	1.B.2.a.1	Exploration, oil	2 A	1000 A
N ₂ O	1.B.2.c.2.i	Flaring, oil	11 E	1000 I
N ₂ O	1.B.2.c.2.ii	Flaring, gas	7.5 E	1000 I
N ₂ O	1.B.2.c.2.iii	Flaring, combined	7.5 E	1000 I

A: DCE assumption.

I: IPCC 2006 Guidelines (default value).

S: Statistisk Sentralbyrå, Statistics Norway, 2008.
 E: EU Emission Trading Scheme (EU ETS).
 H: Holst, 2009 and Statoil A/S, 2010.
 Q: Annual gas quality, Energinet.dk.

The CO₂ emission factors for flaring in upstream oil and gas production and in refineries and the CO₂ and CH₄ emission factors for natural gas transmission, distribution and venting, are the most accurate as they are calculated on basis of gas composition measurements. Emissions factors for flare gas are available in the EU ETS reporting while emissions factors for natural gas are published by Energinet.dk.

The calculation of CO₂ emissions from exploration of oil and gas is based on information on oil and gas quality for most drillings. As the uncertainty levels of the measurements are not available, the double of the uncertainty for flaring in oil and gas extraction (before EU ETS standards) has been used.

The CO₂ emission factor for extraction of oil and gas is based on standard emission factors from IPCC (2006) and the corresponding uncertainties of 100 % are applied in the uncertainty analysis.

The uncertainty level for the emission factor for fugitive CH₄ emissions from refineries is dominated by a large uncertainty for one refinery. Further, measurements of fugitive emissions from the refineries are only available for one and two years, respectively, and these measurements indicate larger emissions than earlier estimates. As more measurements become available, the uncertainty level is expected to decrease.

The emission factors for loading of ships are given as quality C in EMEP/EEA (2019), corresponding an uncertainty level of 50-200 %. The lower level is assumed the most plausible for Danish conditions.

For onshore activities, the emission factor uncertainty corresponds to the uncertainty for onshore loading by Statistics Norway (2008), and the same uncertainty level is assumed for the CH₄ emission factor for onshore activities.

According to IPCC (2006) the emission factor for N₂O is the least reliable, and the uncertainty interval for the N₂O emission factors given for flaring in oil and gas production is -10 % to +1 000 %. An uncertainty level of 1 000 % is adopted in the Danish uncertainty model for all fugitive sources in the Danish inventory (exploration and flaring of oil and gas).

Results

The results of the Approach 1 uncertainty model for 2020 are shown in Table 3.5.13. N₂O has the largest uncertainty for both the total emission and the trend followed by CH₄ and CO₂. The estimated uncertainty for the total GHG emission is 107 % and the GHG emission trend is -62 % ±5 %-point.

Table 3.5.13 Uncertainty estimates for total emissions and emission trends from the Approach 1 uncertainty model.

	1990 emission, kt CO ₂ eqv	2020 emission, kt CO ₂ eqv	Uncertainty, % lower and upper (±)	Trend 1990-2020, %	Uncertainty, % lower and upper (±)
CO ₂	341	126	7	-63	3
CH ₄	133	53	77	-60	10
N ₂ O	53	21	998	-60	15
GHG	526	201	107	-62	5

3.5.6 Source specific QA/QC and verification

The elaboration of a formal QA/QC plan started in 2004 and was updated in 2013 (Nielsen et al., 2013) and latest in 2020 (Nielsen et al., 2020). The plan describes the concepts of quality work and definitions of sufficient quality, Critical Control Points (CCP) and a list of Points of Measuring (PM) (Figure 3.5.22). Please refer to the general Section 1.6 *Information on QA/QC plan including verification and treatment of confidential issues where relevant* for further information.

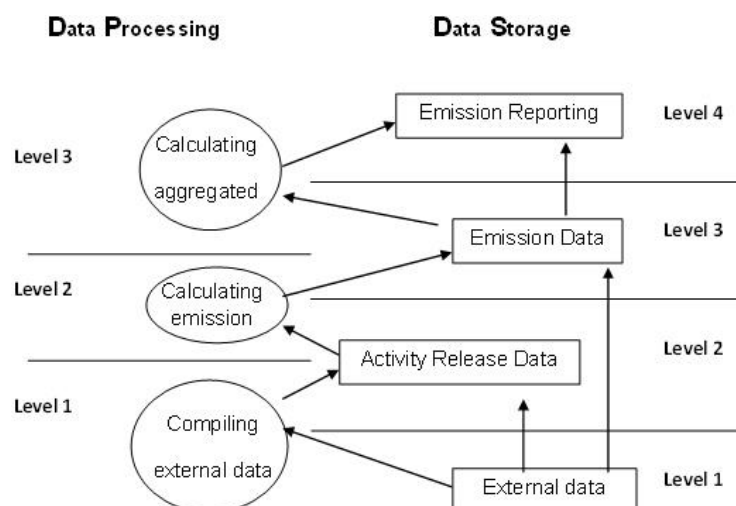

Figure 3.5.22 The general data structure for the Danish emission inventory (Nielsen et al., 2020).

Data storage level 1

Data storage level 1 refers to the data collected by DCE before any processing or preparing. Table 3.5.14 lists the external data deliveries used for the inventory of fugitive emissions. Further, the table holds information on the contacts at the data delivery companies.

Table 3.5.14 List of external data sources.

Category	Data description	Activity data, emission factors or emissions	Reference	Contact(s)	Data agreement /comment
Exploration of oil and gas	Dataset for exploration of oil and gas, including rates and composition.	Activity data	The Danish Energy Agency	Kirsten Lundt Erichsen	Data agreement
Production of oil and gas	Gas and oil production. Dataset, including rates of offshore loading of ships.	Activity data	The Danish Energy Agency	Kirsten Lundt Erichsen	Not necessary due to obligation by law
Offshore flaring	Flaring in upstream oil and gas production (EU ETS data)	Activity data	The Danish Energy Agency	Dorte Maimann	Data agreement
Service stations	Data on gasoline sales from the Danish energy statistics.	Activity data	The Danish Energy Agency	Jane Rusbjerg	Data agreement
Gas transmission	Natural gas transmission rates from the transmission company, sales and losses.	Activity data	Energinet.dk	Signe Sonne	Not necessary due to obligation by law
Onshore activities	Rates of oil transport in pipeline and onshore loading to ships. Emissions from storage of raw oil in the terminal.	Activity data and emission data	Ørsted	Søren Boesen	No formal data agreement.
Gas distribution	Natural gas and town gas distribution rates from the distribution company, sales and losses (meter differences)	Activity data	Dong Energy / Dansk gasdistribution	Susanne Kirkegaard	No formal data agreement.
Emissions from refinery	Fuel consumption and emission data.	Activity data and emission data	Equinor Refining Denmark A/S, A/S Danish Shell	Anette Holst, Trine Bjerre Kristiansen	No formal data agreement.
Treatment and storage of gas	Environmental reports from plants defined as large point sources (Lille Torup, Stenlille, Nybro)	Activity data	Various plants		Not necessary due to obligation by law
CO ₂ emission factors for different sources	Reports according to the CO ₂ emission trading scheme (EU ETS)	Activity data	Various plants		Not necessary due to obligation by law
Emission factors	Emission factors origin from a large number of sources	Emission factors	See Section 3.5.4 <i>Activity data, emission factors and emissions for fugitive sources</i> regarding emission factors		

The following lists the CCPs and the PMs in the Danish QA/QC plan, relevant for the emission inventory for the fugitive sector.

Level	CCP	PM	Description
Data Storage level 1	1. Accuracy	DS.1.1.1	General level of uncertainty for every dataset including the reasoning for the specific values.

The uncertainty for every dataset included in the inventory of fugitive emissions are evaluated and included in the Tier 1 uncertainty calculations with short descriptions of the reasoning behind the specific values. The general levels of uncertainty are relatively low. The largest uncertainties are expected for emissions from refineries and distribution of town gas, the latter being of minor importance to the total fugitive emissions. For further comments regarding uncertainties, see Section 3.5.5 *Uncertainties and time series consistency*.

Level	CCP	PM	Description
Data Storage level 1	2. Comparability	DS.1.2.1	Comparability of the emission factors/calculation parameters with data from international guidelines, and evaluation of major discrepancies.

Systematic inter-country comparison has only been made on Data Storage Level 4. Refer to DS.4.3.2 in Section 1.6 *Information on QA/QC plan including verification and treatment of confidential issues where relevant.*

Level	CCP	PM	Description
Data Storage level 1	3.Completeness	DS.1.3.1	Ensuring that the best possible national data for all sources are included, by setting down the reasoning behind the selection of datasets.

External data include energy statistics from the Danish Energy Agency, EU ETS reports and annual environmental reports from a number of plants and companies. Further, supplementary information are gathered annually from some companies. Only one national data set is found for most fugitive sources, and all data sets are expected to be complete and include all activities/emissions from the sources. Data on flaring in upstream oil and gas production, in refineries and in gas treatment and storage facilities are available both in annual environmental reports and in EU ETS reports. Data are compared and if any differences occur, this is checked with the data suppliers. Minor differences may owe to the allocation of fuels, e.g. if pilot gas are included in the flare gas or the fuel gas rate.

Energy statistics

The Danish Energy Agency reports fuel consumption statistics on the SNAP level based on a correspondence table developed in co-operation with DCE. Both traded and non-traded fuels are included in the Danish energy statistics. Data on production and flaring in upstream oil and gas production, and gasoline sales are used for estimation of fugitive emissions.

Environmental reports

A large number of plants are obligated by law to publish an environmental report annually with information on e.g. fuel consumption and emissions. DCE compares data with those from previous years, discrepancies are checked, and large fluctuations are verified.

Annual reports

The gas distribution companies and the raw oil terminal are not obligated to publish environmental reports. Instead, the self-regulation reports, annual reports and/or additional information are used. All information is compared with data for previous years.

Reports for the European Union Greenhouse Gas Emission Trading System (EU ETS)

CO₂ emission factors for offshore in upstream oil and gas production and in refineries are taken from the EU ETS reports since 2006, when the EU ETS reports became available. EU ETS reports are available individually for the Danish oil/gas production fields and refineries.

Emission factors from a wide range of sources

For specific references, see Section 3.5.4 *Activity data, emission factors and emissions for fugitive sources.*

Level	CCP	PM	Description
Data Storage level 1	4.Consistency	DS.1.4.1	The original external data has to be archived with proper reference.

All external data are stored in the inventory file system and are accessible for all inventory staff members. Data processing is carried out in separate spread sheets to ensure that the external data are always available in the original form. Data sources are referenced in the spread sheets. Refer to Section 1.3. *Brief description of the process of inventory preparation. Data collection and processing, data storage and Archiving.*

Level	CCP	PM	Description
Data Storage level 1	6.Robustness	DS.1.6.1	Explicit agreements between the external institution holding the data and DCE about the conditions of delivery

Formal agreements are made with the Danish Energy Agency. Annual environmental reports are available due to legal requirements. The remaining data are published or delivered by the companies on voluntary basis. See Table. 3.5.14.

Level	CCP	PM	Description
Data Storage level 1	7.Transparency	DS.1.7.1	Listing of all archived datasets and external contacts.

See DS 1.3.1 and Table 3.5.14.

Data Processing Level 1

Level	CCP	PM	Description
Data Processing level 1	1. Accuracy	DP.1.1.1	Uncertainty assessment for every data source not part of DS.1.1.1 as input to Data Storage level 2 in relation to type and scale of variability.

Refer to Section 1.7 *General uncertainty evaluation, including data on the overall uncertainty for the inventory totals* in the Danish NIR and Section 3.5.6 *Source specific QA/QC and verification.*

Level	CCP	PM	Description
Data Processing level 1	2.Comparability	DP.1.2.1	The methodologies have to follow the international guidelines suggested by UNFCCC and IPCC.

The methodologies in the inventory follow the principles in international guidelines by UNFCCC and IPCC.

Level	CCP	PM	Description
Data Processing level 1	3.Completeness	DP.1.3.1	Identification of data gaps with regard to data sources that could improve quantitative knowledge.

Data gaps are found for distribution of town gas, as more companies are closed before this source was included in the Danish inventory. Emissions, which account for only a limited part of the total fugitive emissions, are calculated on a scarce data foundation. Also further information regarding VOC emissions from refineries would be preferred, but are not available. DCE continue the collaboration with the refineries update the methodology and emission estimates if new information become available.

Level	CCP	PM	Description
Data Processing level 1	4.Consistency	DP.1.4.1	Documentation and reasoning of methodological changes during the time series and the qualitative assessment of the impact on time series consistency.

Since 2006, the EU ETS data have been available for a number of sources. In all cases, the new data replace use of data assumed to be less accurate. Therefore, the CO₂ emission factors have been updated for all years, and no methodological change occur in the time series.

A change in the calculating procedure would entail elaboration of an updated description in Section 3.5.4 *Activity data, emission factors and emissions for fugitive sources*.

Level	CCP	PM	Description
Data Processing level 1	5.Correctness	DP.1.5.2	Verification of calculation results using time series

Time series for activity data, emission factors and/or emissions on SNAP level are used to identify possible errors in the calculation procedure.

Level	CCP	PM	Description
Data Processing level 1	5.Correctness	DP.1.5.3	Verification of calculation results using other measures

For fugitive sources, only one data set is available for calculation, and no verification using other measures are possible. For sources where activity data is available in more data sources (e.g. in both EU ETS and annual reports), data are compared and reasons for any differences are clarified.

Level	CCP	PM	Description
Data Processing level 1	7.Transparency	DP.1.7.1	The calculation principle, the equations used and the assumptions made must be described.

Descriptions are included in the NIR in Section 3.5.4 *Activity data, emission factors and emissions for fugitive sources*.

Level	CCP	PM	Description
Data Processing level 1	7.Transparency	DP.1.7.2	Clear reference to dataset at Data Storage level 1

Notes on data sources are included in the calculation files for all input data.

Level	CCP	PM	Description
Data Processing level 1	7.Transparency	DP.1.7.3	A manual log to collect information about recalculations.

A log holding information on recalculations are included in the national inventory system. Further, a log is prepared annually holding information on status of the inventory work and recalculations for each source in the fugitive sector.

Data storage level 2

Level	CCP	PM	Description
Data Storage level 2	5.Correctness	DS.2.5.1	Check if a correct data import to level 2 has been made

To ensure a correct connection between data on level 2 to data on level 1, different controls are in place, e.g. control of sums and random tests.

Data storage level 4

Level	CCP	PM	Description
Data Storage level 4	4.Consistency	DS.4.4.3	The IEFs from the CRF are checked both regarding level and trend. The level is compared to relevant emission factors to ensure correctness. Large dips/jumps in the time series are explained.

Time series for IEFs are checked to identify large fluctuations, which are afterwards investigated and explained. The level of the IEFs are compared to other relevant EFs, e.g. in standard EFs in guidebooks and guidelines.

Other QC procedures

A list of QA/QC tasks are performed directly in relation to the fugitive emission part of the Danish emission inventories. The following procedures are carried out to ensure the data quality:

- The emission from the large point sources (refineries, gas treatment and gas storage facilities) is compared with the emission reported the previous year.
- Annual environmental reports are kept for subsequent control of plant-specific emission data.
- Checks of data transfer are incorporated in the fugitive emission models, e.g. sum checks.
- Verification of activity data from external data when data are available through more data sources (production and flaring rates in upstream oil and gas production).
- Data sources are incorporated in the fugitive emission models
- A manual log table in the emission databases is applied to collect information about recalculations.
- Comparison with the inventory of the previous year. Any major changes are verified.
- Total emission, when aggregated to reporting tables, is compared with totals based on SNAP source categories (control of data transfer).
- Checking of time series in the CRF and SNAP source categories. Significant dips and jumps are controlled and explained.

External review

A documentation report for the sector "The Danish emission inventory for fugitive emissions from fuels" was published in 2021. The report includes detailed information on the methodology used in the emission inventories for greenhouse gases and air pollution (Plejdrup et al., 2021). The report was reviewed by Jesper Werner Løhndorf Christensen from the Danish Energy Agency.

The previous versions of the documentation report from 2015 and 2009 was reviewed by Glen Thistlethwaite from Ricardo Energy & Environment, Oxfordshire, UK and by Anette Holst, Statoil A/S, The Refinery, Kalundborg, Denmark, respectively.

3.5.7 Recalculations

CO₂

Catalytic regeneration

CO₂ emissions from catalytic regeneration at refineries have been added as a new source (snap 040105). Emissions are based on EU-ETS reports and extrapolation for years before EU-ETS reporting. This recalculation increase the CO₂ emissions between 0.025 kt (2013) and 1.153 kt (2017), corresponding 0.01 % and 0.5 % of the total sectoral CO₂ emission.

Flaring

Flaring at a refinery that closed down in 1996 has been corrected for 1994 as this erroneously has been included as both LPS and area source leading to double counting. This has reduced the emission in 1994 by 2.97 kt CO₂. This recalculation result in minor change of CH₄ and N₂O emissions.

The CO₂ emission factors have been updated for flaring in gas storage for the entire time series, and for flaring in gas transmission and distribution for 2011-2019. The latter is based on updated data from the transmission and distribution companies. The recalculation has changed the CO₂ emissions between -0.03 kt (2002) and 0.04 kt (2011). For CH₄, the largest recalculation is -0.02 kt (1994) and is of minor importance for the years 1995-2019.

The CO₂ emission factor for offshore flaring in oil and gas production has been corrected (change of rounding) for 2017-2019. The recalculation is between 0.29 kt (2019) and 0.36 kt (2017), corresponding 0.2 % and 0.1 % of the total sectoral CO₂ emission.

CH₄

Gas transmission

Activity data for transmission loss has been updated for 2010-2019 according to new data from the gas transmission company Energinet.dk. CH₄ emissions have changed between 0.05 kt (2016) and 0.14 kt (2012), corresponding 1.0 % and 2.5 % of the total sectoral CH₄ emission.

Gas distribution

Activity data for gas loss in gas distribution has been updated for 2019 according to new data from the distribution company, resulting in an increase of 0.01 kt CH₄, corresponding 0.4 % of the total sectoral CH₄ emission.

The CH₄ emission factor has been corrected for 1998, 2003 and 2016 due to an error. This recalculation results in minor change of emissions.

Flaring

CH₄ emission factors for flaring in gas storage plant have been corrected for 1994-2019. This recalculation results in minor change of emissions. The largest recalculation is for the years 1990-1994 with -0.02 kt in 1994. This recalculation results in minor change of emissions for the remaining years.

N₂O

Only minor recalculations.

3.5.8 Source specific implemented improvements

CO₂ emissions from regeneration of catalysts at refineries has been included in the inventory. The methodology and data are described in Chapter 3.5.4.

3.5.9 Response to the review process

A review of the Danish 2021 submission took place from 6th to 11th September 2021. At the time of preparing this report, Denmark had not yet received a draft review report. Therefore, the table below represents the latest available report.

Denmark has received provisional main findings for the 2021 review. This includes no findings for the fugitive emissions sector.

Table 3.5.15 contains the recommendations of the most recent UNFCCC review of the Danish greenhouse gas inventory. The table details the status of implementation of the recommendations as well as references to where improvements have been implemented in this report.

Table 3.5.15 Response to the review process.

Para.	CRF	ERT Comment	Denmark's response	Reference
				2020 submission (Review report: https://unfccc.int/sites/default/files/resource/arr2020_DNK.pdf)
				No findings for CRF 1.B Fugitive emissions from fuels

3.5.10 Source specific planned improvements

A review of the inventory for fugitive emissions from gas transmission and distribution is planned within the next year. Depending on the findings during the review, potential changes are assumed included in the 2023 or 2024 submission.

3.5.11 References

A/S Dansk Shell - Havneterminalen, 2013: Annual Report for the Harbour Terminal (in Danish).

A/S Dansk Shell - Havneterminalen, 2014: Annual Report for the Harbour Terminal (in Danish).

A/S Dansk Shell - Havneterminalen, 2015: Annual Report for the Harbour Terminal (in Danish).

A/S Dansk Shell - Havneterminalen, 2016: Annual Report for the Harbour Terminal (in Danish).

A/S Dansk Shell - Havneterminalen, 2017: Annual Report for the Harbour Terminal (in Danish).

A/S Dansk Shell - Havneterminalen, 2018: Annual Report for the Harbour Terminal (in Danish).

A/S Dansk Shell - Havneterminalen, 2019: Annual Report for the Harbour Terminal (in Danish).

A/S Dansk Shell - Havneterminalen, 2020: Annual Report for the Harbour Terminal (in Danish).

A/S Dansk Shell - Havneterminalen, 2021: Annual Report for the Harbour Terminal (in Danish).

A/S Dansk Shell, 2021: Annual environmental report.

API, 2009: Compendium of Greenhouse Gas Emissions Estimation Methodologies for the Oil and Natural Gas Industry. American Petroleum Institute. Available at:
https://www.api.org/~media/files/ehs/climate-change/2009_ghg_compendium.ashx (06-01-2022).

Boesen, S. 2021: Personal communication, e-mail correspondence 18/8 2021, Orsted.

Danish Energy Agency, 2021a: Data for oil and gas production in Denmark. Available at:
<https://ens.dk/en/our-services/oil-and-gas-related-data/monthly-and-yearly-production> (06-01-2021). Reports for earlier years. Available at:
<https://ens.dk/en/our-responsibilities/oil-gas/reports-oil-and-gas-activities> (06-01-2021).

Danish Energy Agency, 2021b: The Danish energy statistics (Energistatistik) (in Danish). Available at:
<https://ens.dk/en/our-services/statistics-data-key-figures-and-energy-maps/annual-and-monthly-statistics> (06-01-2022).

Danish EPA, 2017: Environmental approval for A/S Dansk Shell. 27/3 2017. Available at: <https://mst.dk/media/97091/20170327-shell-havneterminal-miljoegodkendelse-samlet.pdf> (06-01-2022).

Ea Energianalyse, 2014: Anvendelse af biogas i naturgas i København (in Danish).

EMEP/EEA, 2019: Air emission inventory guidebook, prepared by the UNECE/EMEP Task Force on Emission Inventories and Projections, 2016 update. Available at:
<https://www.eea.europa.eu/publications/emep-eea-guidebook-2019> (06-01-2022).

Energinet.dk, 2021a: Environmental reports and supplementary data for Lille Torup and Stenlille gas storage facilities. Personal communication, e-mail correspondence 17/8 2021, Christian Guldager Corydon.

Energinet.dk, 2021b: Data for gas loss and flaring in gas transmission. Personal communication, e-mail correspondence 21/10 2022, Signe Sonne.

Energinet.dk, 2021c: Annual gas quality. Available at:
<https://en.energinet.dk/Gas/Gas-Quality/Yearly-Average-Gas-Quality> (06-01-2022).

Equinor Refining Denmark A/S, 2021: Sustainability report (in Danish). Available at: <https://www.equinor.com/en/sustainability/our-approach/sustainability-reports.html> (06-01-2022).

Erichsen, K.L. 2021: Personal communication, e-mail correspondence 23/8 2021, Danish Energy Agency.

EU Commission, 2018: COMMISSION IMPLEMENTING REGULATION on the monitoring and reporting of greenhouse gas emissions pursuant to Directive 2003/87/EC of the European Parliament and of the Council and amending Commission Regulation (EU) No 601/2012. Available at: <https://eur-lex.europa.eu/legal-content/EN/TXT/PDF/?uri=CELEX:32018R2066&from=EN> (06-01-2022).

Hjerrild and Rasmussen, 2014: Fugitive VOC from refineries.

Holst, A. 2009: Personal communication, e-mail 18-11-2009, Statoil A/S.

IPCC, 2006: 2006 IPCC Guidelines for National Greenhouse Gas Inventories. Available at: <http://www.ipcc-nggip.iges.or.jp/public/2006gl/index.html> (06-01-2022).

Jensen, 2008: Town gas distribution loss. Documentation for expert judgement.

Jeppesen, 2014: Biogas i bygas - biogasrense- og bygasproduktionsanlæg. Presentation at Gastekniske data 14/05/2014 (in Danish).

Karll, B. 2002: Personal communication, e-mail 2002, Danish Gas Technology Centre.

Karll, B. 2003: Personal communication, e-mail 2003, Danish Gas Technology Centre.

Karll, B. 2004: Personal communication, e-mail 2004, Danish Gas Technology Centre.

Karll, B. 2005: Personal communication, e-mail 2005, Danish Gas Technology Centre.

Miljø- og Planlægningsudvalget, 2009a: MPU alm. del, endeligt svar på spørgsmål 952. Miljøteknisk beskrivelse - A/S Dansk Shell, Shell- Raffinaderiet. Available at: <https://www.ft.dk/samling/20091/alm-del/mpu/spm/952/svar/739623/891170/index.htm> (06-01-2022).

Nielsen, O.-K., Plejdrup, M.S., Winther, M., Gyldenkærne, S., Thomsen, M., Fauser, P., Nielsen, M. Mikkelsen, M.H., Albrektsen, R., Hjelgaard, K., Hoffmann, L. & Bruun, H.G., 2013: Quality manual for the Danish greenhouse gas inventory. Version 2. Aarhus University, DCE - Danish Centre for Environment and Energy, 44 pp. Scientific Report from DCE - Danish Centre for Environment and Energy No. 47. Available at: <http://www.dmu.dk/Pub/SR47.pdf> (06-01-2022).

Nielsen, O.-K., Plejdrup, M.S., Winther, M., Gyldenkærne, S., Thomsen, M., Nielsen, M. Mikkelsen, M.H., Albrektsen, R., Hjelgaard, K., & Bruun, H.G., 2020: Quality manual for the Danish greenhouse gas inventory. Version 3. Aarhus University, DCE – Danish Centre for Environment and Energy. Available at: <https://dce2.au.dk/pub/SR406.pdf> (06-01-2022).

Nielsen, O.-K., Plejdrup, M.S., Winther, M., Mikkelsen, M.H., Nielsen, M., Gyldenkærne, S., Fauser, P., Albrektsen, R., Hjelgaard, K., Bruun, H.G. & Thomsen, M., 2022: Annual Danish Informative Inventory Report to UNECE. Emission inventories from the base year of the protocols to year 2020. Aarhus University, DCE – Danish Centre for Environment and Energy. (In prep.).

Oertenblad, M. 2006: Personal communication, e-mail 2006, Danish Gas Technology Centre.

Oertenblad, M. 2007: Personal communication, e-mail 2007, Danish Gas Technology Centre.

Plejdrup, M.S., Nielsen, O.-K. & Nielsen, M. 2021. The Danish emission inventory for fugitive emissions from fuels. Aarhus University, DCE – Danish Centre for Environment and Energy, 61 pp. Scientific Report No. 463. <http://dce2.au.dk/pub/SR463.pdf> (06-01-2022).

Statistics Norway, 2008: The Norwegian Emission Inventory 2008. Documentation of methodologies for estimating emissions of greenhouse gases and long-range transboundary air pollutants. 252 pp. Statistisk Sentralbyrå. Reports 2008/48. Available at: http://www.ssb.no/english/subjects/01/sa_nrm/nrm2008/sa109.pdf (06-01-2022).

Statoil A/S, 2010: Ubestemtheden på massestrømmen ved blændemåling og ultralyd. Report in Danish.

OLF, 1993: The Norwegian Oil industry Association, OLF environmental program. Phase II. Summary report. 1993.

4 Industrial Processes and Product Use

4.1 Overview of the sector

The *Industrial Processes and Product Use* (IPPU) sector covers greenhouse gases (GHG) from industrial processes not related to generation of energy along with emissions from product use. The IPPU sector consists of the following CRF source categories:

- 2A Mineral Industry
- 2B Chemical Industry
- 2C Metal Industry
- 2D Non-Energy Products from Fuels and Solvent Use
- 2E Electronics Industry
- 2F Product Uses as Substitutes for Ozone Depleting Substances (ODS)
- 2G Other Product Manufacture and Use

The data presented in Chapter 4 relate to Denmark only, whereas information for Greenland is included in Chapter 16 and for the Faroe Islands in Annex 7.

For a more detailed description of the methods used and the verifications performed, please refer to the sectoral method report Hjelgaard & Nielsen (2018).

4.1.1 Methodology overview

Table 4.1.1 gives a brief overview over methodologies applied for the IPPU sector. Further description of the applied methodologies can be found in the following chapters.

Table 4.1.1 Overview of methodologies used for the 2019 data (or the latest active year for activities that have ceased).

IPCC code	Process	Substance	Tier	EF	Key category 1990/2020/ trend
2A1	Cement production*	CO ₂	T3	PS	Yes/Yes/Yes
2A2	Lime production	CO ₂	T2	PS/CS	No/No/No
2A3	Glass production	CO ₂	T3	PS	No/No/No
2A4a	Ceramics	CO ₂	T3	CS	No/No/No
2A4b	Other uses of soda ash	CO ₂	T3	D	No/No/No
2A4d	Other process uses of carbonates	CO ₂	CS/T3	D	No/No/No
2B2	Nitric acid production	N ₂ O	T2	PS	Yes/No/Yes
2B10	Catalyst production	CO ₂	CS	PS	No/No/No
2C1	Iron and steel production*	CO ₂	T1	CS, D	No/No/No
2C4	Magnesium production	SF ₆	T2	D	No/No/No
2C5	Secondary lead production	CO ₂	T1	D	No/No/No
2D1	Lubricant use	CO ₂	T1	D	No/No/No
2D2	Paraffin wax use	CO ₂ , N ₂ O, CH ₄	T2	OTH/D	No/No/No
2D3	Paint application	CO ₂	CS/T2	CS	No/No/No
2D3	Degreasing, dry cleaning and electronics	CO ₂	CS/T2	CS	No/No/No
2D3	Chemical products manufacturing or processing	CO ₂	CS/T2	CS	No/No/No
2D3	Other use of solvents and related activities	CO ₂	CS/T2	CS	No/No/No
2D3	Road paving with asphalt	CO ₂ , CH ₄	T2	OTH	No/No/No
2D3	Asphalt roofing	CO ₂	T2	OTH	No/No/No
2D3	Urea-based catalysts	CO ₂	T3	D	No/No/No
2E5	Other electronics industry	HFCs, PCFs	T2	D	No/No/No
2F1	Refrigeration and air conditioning	HFCs, PFCs	T2	D/CS	No/Yes/Yes
2F2	Foam blowing agents	HFCs	T2	D	Yes/No/Yes
2F4	Aerosols	HFCs	T2	D	No/No/No
2F5	Solvents	PFCs	T2	D	No/No/No
2G1	Electrical equipment	SF ₆	T3	D	No/No/No
2G2	SF ₆ and PFCs from other product use	SF ₆	T2	D	No/No/No
2G3a	Medical application	N ₂ O	T1	D	No/No/No
2G3b	Propellant for pressure and aerosol products	N ₂ O	T1	D	No/No/No
2G4	Other product uses	CO ₂ , CH ₄ , N ₂ O	T2	D/CS/OTH	No/No/No

* The methodology used for this category varies over the time series, see Table 4.1.2.

Table 4.1.2 Overview of implemented methodologies for categories where the methodology varies over the time series.

Process	Years	Available activity data	Available emission factors	Resulting methodology
2A1 Cement production	1990-1997	Production of white cement and production of three types of grey clinker.	Plant specific factors for the three individual grey clinker types and for white cement.	Tier 1/PS
	1998-2020	Consumption of raw materials.	Plant specific measured carbonate content of raw materials.	Tier 3/PS
2A4a Ceramics	1990-2005	Estimated CaCO ₃ eqv data based on national statistics	Country specific	Tier 2/CS
	2006-2020	Plant specific data on carbonate consumption	Country specific	Tier 3/CS
2A4d Other process uses of carbonates	1990-2005	Estimated CaCO ₃ data based on total produced flue gas cleaning residue	Default	Tier 2/D
	2006-2020	Plant specific data on carbonate consumption	Default	Tier 3/D
2C1 Iron and steel production	1990-1992, 2005	Extrapolation, interpolation, expert judgement	Expert judgement	Tier 1/CS,D
	1993-2001	Environmental reports	Environmental reports	Tier 2/CS,D

4.1.2 Key categories

A Key Category Analysis (KCA) for the years 1990 and 2020 as well as for the trend has been carried out. The result for the IPPU sector is shown in Table 4.1.3. A detailed KCA is presented in Chapter 1.5 and Annex 1. The calculations are based on national emissions including LULUCF but excluding Greenland and the Faroe Islands.

The analysis is carried out using both Approach 1 and Approach 2 methods. Four categories are identified as key categories in IPPU in this submission, all four for both level and trend.

Table 4.1.3 Key Category Analysis for Industrial Processes and Product Use.

IPCC code	Process	Substance	Approach 1			Approach 2		
			1990	2020	1990-2020	1990	2020	1990-2020
2A1	Cement production	CO ₂	Level	Level	Trend			
2B2	Nitric acid production	N ₂ O	Level		Trend	Level		Trend
2F1	Refrigeration and air conditioning	HFCs		Level	Trend		Level	Trend
2F2	Foam blowing agents	HFCs	Level		Trend			Trend

Only source categories identified as key categories are presented in Table 4.1.3, for a full overview of the source categories included in this inventory please refer to Table 4.1.1.

4.1.3 Emission overview

An overview of the most significant sources in 2020 is presented in Table 4.1.4; these five source categories comprise more than 90 % of emissions in CO₂ equivalents (CO₂ eqv) from IPPU. The table below also gives an indication of the contribution to the total emission of greenhouse gases in 2020 in the IPPU sector.

Table 4.1.4 Overview of the largest sources to greenhouse gas emissions in the IPPU sector in 2020.

Process	IPCC Code	Substance	Emission kt CO ₂ eqv	%*
Cement production	2A1	CO ₂	1227	63.7
Refrigeration and air conditioning	2F1	HFCs, PFCs	323	16.8
Other ¹	2D3	CO ₂ , CH ₄	80	4.1
Other process uses of carbonates ²	2A4	CO ₂	73	3.8
Paraffin wax use	2D2	CO ₂ , CH ₄ , N ₂ O	58	3.0
Total of five largest sources			1761	91.4

*of total CO₂ equivalent emissions from the IPPU sector.

¹ 2D3 consists of solvent use, road paving with asphalt, asphalt roofing and urea use in vehicle catalysts. ² 2A4 consists of ceramics, other uses of soda ash, flue gas desulphurisation and stone wool production.

For 2020, the subsector Mineral Industry (2A) constitutes 70 % of the GHG emissions from the IPPU sector and Product Uses as Substitutes for ODS (2F) constitutes 17 %. Non-Energy Products from Fuels and Solvent Use (2D) and Other Product Manufacture and Use (2G) constitutes 9 and 3 % respectively, while Chemical Industry (2B) and Metal production (2C) together constitutes below 0.1 %. The total emission of greenhouse gases (excl. LULUCF) in Denmark in 2020 is estimated to 41.5 Mt CO₂ equivalents of which IPPU contribute with 1.9 Mt CO₂ equivalents (4.6 %). The emissions of GHG from IPPU from 1990-2020 are presented in Figure 4.1.1.

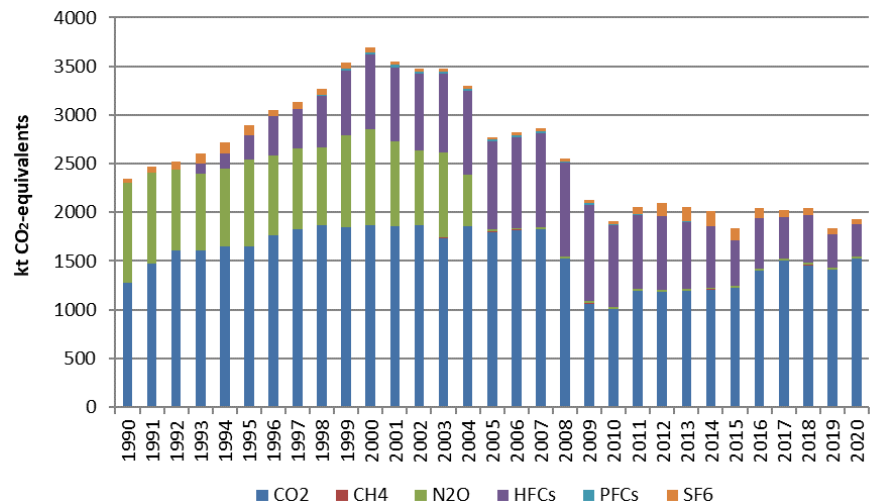

Figure 4.1.1 Emission of individual- and total greenhouse gases from IPPU (CRF Sector 2) from 1990-2020.

The majority of CO₂ emissions in the IPPU sector are emitted from the cement production, the small drop in CO₂ emissions in 2003 and the larger decrease in 2008-2010 are caused by a lower production of cement for these years. The production of nitric acid closed down during 2004 causing the N₂O emission to drop drastically; from 764-1020 kt CO₂ equivalents in 1990-2003 to 16-22 kt CO₂ equivalents in 2005-2020. The use of HFCs in mainly refrigeration and air conditioning has increased significantly during the time series but is decreasing in recent years. HFC emissions peaked in 2009 with 989 kt CO₂ equivalents, but has decreased to 335 kt CO₂ equivalents in 2020.

4.1.4 EU-ETS (EU Emission Trading Scheme)

Guidelines for calculating company specific CO₂ emissions are developed by the EU (EU Commission, 2018). The guidelines present standard methods for minor companies and methods for developing individual plans for major companies. The standard methods include default emission factors similar to the default emission factors presented by IPCC (e.g. for limestone), whereas, the major companies have to use individual methods to determine the actual composition of raw materials (e.g. purity of limestone or Ca per tonne ratio in dolomite) or the actual CO₂ emission from the specific process. Where data from the EU-ETS are used more detail is provided on the specific methodologies used in the specific chapter. This is the case in the following categories:

- Cement production
- Lime production
- Glass production
- Ceramics
- Flue gas desulphurisation
- Stone wool production

4.2 Mineral Industry

4.2.1 Source category description

The sector *Mineral Industry* (CRF 2A) covers the following industries relevant for the Danish air emission inventory:

- 2A1 Cement production (SNAP 040612); see section 4.2.3.
- 2A2 Lime production (SNAP 040614); see section 4.2.4.

- 2A3 Glass production (SNAP 040613); see section 4.2.5.
- 2A4a Ceramics (SNAP 040691, 040692); see section 4.2.6.
- 2A4b Other uses of soda ash (SNAP 040619); see section 4.2.7.
- 2A4d Flue gas desulphurisation (SNAP 040618); see section 4.2.8.
- 2A4d Stone wool production (SNAP 040618); see section 4.2.9.

Cement production is identified as key category according to Approach 1 for level in 1990 and 2020 and for trend; see *Annex 1: Key Category Analyses*.

4.2.2 Emissions

Total greenhouse gas emissions from the Mineral Industry sector are available in the CRF Table 10. The emission time series for the source categories within *Mineral Industry (2A)* are presented in Figure 4.2.1 and individually in the subsections below (Sections 4.2.3 – 4.2.9). The following figure gives an overview of how much the individual source categories contribute throughout the time series.

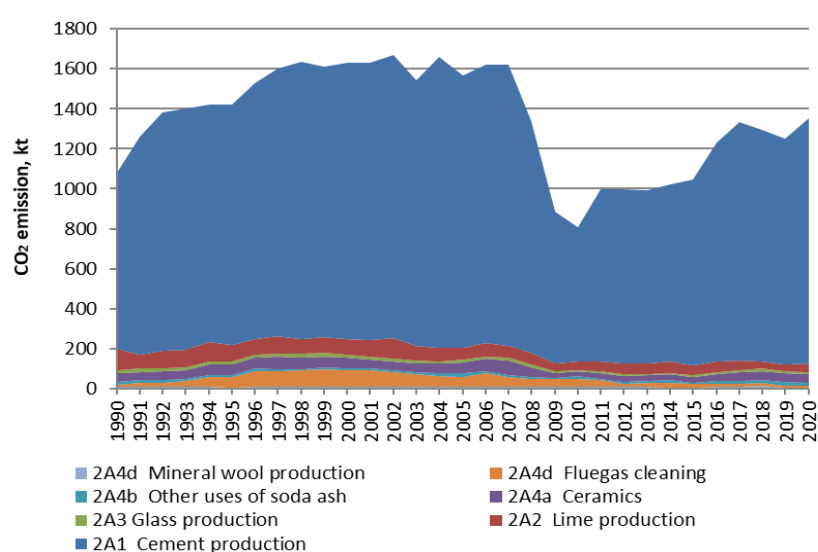

Figure 4.2.1 Emission of CO₂ from the individual source categories compiling 2A *Mineral Industry*, kt.

Greenhouse gas emissions from *Mineral Industry* are made up mostly by CO₂ emissions from the production of cement; min. 82 % (1990) to max. 91 % (2020).

Emissions from *Mineral Industry* increased with 54 % from 1990 to the time series peak in 2002 (2002 emission: 1670 kt CO₂). The overall development in the CO₂ emission for 1990 to 2020 shows an increase from 1081 kt CO₂ to 1353 kt CO₂, i.e. 25 %.

The increase from 1990 to 1997 can be explained by the increase in the annual cement production. The emission factor has only changed slightly as the distribution between types of cement especially grey/white cement has been almost constant from 1990-1997. The increase in emissions from 2010-2017 may be explained by an increase in the construction activity after the financial crisis in 2008-2010 and hence an increase in cement demand and production.

4.2.3 Cement production

The production of cement in Denmark is concentrated at one company: Aalborg Portland A/S situated in Aalborg. The following SNAP-code is covered:

- 04 06 12 Cement (decarbonising)

Emissions associated with fuel combustion in cement kilns are estimated and reported in the energy sector. Only emissions related to the calcination of non-fuel feedstock to cement kilns are reported under category 2A.

Methodology

Process emissions are released from the calcination of raw materials (primarily chalk and sand). The overall process for calcination is:



The primary raw materials are sand, chalk and water and the main products are grey cement, white cement and cement clinker for sale.

Aalborg Portland uses a semi-dry process. The first step is production of raw meal. The chalk slurry and the grounded sand are mixed as slurry that is injected into a drier crusher. The raw materials are converted into raw meal that releases carbon dioxide (CO₂) in the calciner.

In a rotary kiln, the material is burned to clinker that afterwards is grounded to cement in the cement mill. During the process, cement kiln dust is recirculated.

The emission of CO₂ depends on the ratio: white/grey cement and the ratio between the three types of clinker used for grey cement: GKL-clinker/FKH-clinker/SKL-RKL-clinker.

For 1990-1997, the ratio white/grey cement and the ratio GKL-clinker/FKH-clinker/SKL-RKL-clinker is known. White cement peaked in 1990 and decreased thereafter. The production of SKL/RKL-clinker peaks in 1991 and decreases hereafter. FKH-clinker is introduced in 1992 and increases to a share of 35 % in 1997. The CO₂ emission is calculated according to the following equation:

$$M_{CO_2} = M_{grey} * \frac{M_{GLK} * EF_{GLK} + M_{FKH} * EF_{FKH} + M_{SKL/RKL} * EF_{SKL/RKL}}{M_{GLK} + M_{FKH} + M_{SKL/RKL}} + M_{white} * EF_{white}$$

M _{grey}	Grey cement	t
M _{white}	White cement	t
M _{GLK}	GKL clinker (rapid cement)	t
M _{FKH}	FKH clinker (basis cement)	t
M _{SKL/RKL}	SKL/RKL clinker (low alkali cement)	t
EF _{white}	CO ₂ emission factor	t/t white cement
EF _{GLK}	CO ₂ emission factor	t/t GLK clinker
EF _{FKH}	CO ₂ emission factor	t/t FKH clinker
EF _{SKL/RKL}	CO ₂ emission factor	t/t SKL/RKL clinker

The company has at the same time stated that data until 1997 cannot be improved as there are no further information available. Data for white cement is therefore used as an estimate for white clinker making the methodology used for the years 1990-1997 a Tier 1.

From 1998-2004 carbonate content of the raw materials has been determined by loss on ignition methodology. Determination of loss on ignition takes into

account all the potential raw materials leading to release of CO₂ based on full oxidation and omits the Ca-sources leading to generation of CaO in cement clinker without CO₂ release. The applied methodology is in accordance with EU guidelines on calculation of CO₂ emissions (Aalborg Portland, 2008). Clinker data are available.

From the year 2005 the CO₂ emission determined by Aalborg Portland, independently verified and reported under the EU-ETS (EU Emission Trading Scheme) is used in the inventory (Aalborg Portland, 2021a). The reporting to EU-ETS also provides detailed information of alternative fuels used in the production of clinker and the amount of clinker produced.

EU-ETS data for cement production

Cement production applies the Tier 3 methodology for calculating the CO₂ emission for 1998-2020.

The implied CO₂ emission factor for Aalborg Portland is plant specific and based on the reporting to the EU-ETS. The EU-ETS data have been applied for the years 2006 – 2020.

The CO₂ emission for cement production is based on measurements of the consumption of calcium carbonate to the calcination process. These measurements fulfil a Tier 3 methodology ($\pm 1.6\%$) as defined in the EU decision (EU Commission, 2018). The emission factor is based on continuous measurements with flow meters, density meters, X-ray and CaO analysis. (Aalborg Portland, 2013b).

Activity data

Activity data for cement (measured in total cement equivalents (TCE)) and clinker production are presented in Table 4.2.1 and Annex 3C-1. Emissions are based on clinker production alone, cement production data are used for verification.

Table 4.2.1 Production statistics for cement and clinker production, kt (Aalborg Portland, 2008, 2013a, 2020, 2021a, b).

	1990	1995	2000	2005	2010	2015	2017	2018	2019	2020
kt TCE	1620	2274	2613	2706	1454	1902	2416	2360	2342	2444
kt clinker ¹	1406	2353	2452	2521	1314	1715	2170	2141	2146	2240

¹ 1990-1997: Clinker production is estimated as grey clinker plus white cement (Aalborg Portland, 2008).

Emission factors

The calculated implied emission factors (IEF) for cement production are presented in Table 4.2.2 and Annex 3C-2.

Table 4.2.2 Implied emission factors for CO₂ for cement production.

	1990	1995	2000	2005	2010	2015	2017	2018	2019	2020
IEF t CO ₂ per t TCE ^{1,2,3}	0.545	0.529	0.530	0.504	0.462	0.490	0.494	0.491	0.482	0.502
IEF t CO ₂ per t clinker ^{3,4}	0.628	0.512	0.565	0.541	0.512	0.543	0.550	0.542	0.526	0.548

¹ 1990-1997: IEF based on information provided by Aalborg Portland (2005).

² 1998-2004: IEF based on information provided by Aalborg Portland (2008).

³ 2005-2019: IEF based on emissions reported to EU-ETS (Aalborg Portland, 2021a).

⁴ 1998-2019: IEF based on clinker production statistics provided by Aalborg Portland (2020, 2021b).

The IEF for CO₂ from the calcination process is expressed per tonne of cement or clinker and depends on the actual input of chalk/limestone in the process. The IEF will therefore vary as the allocation of different cement/clinker types

produced varies. When the implied CO₂ emission factor in 1990 is markedly higher than for the remaining time series it is because the production of white cement was higher in 1990 than for the following years, leading the ratio white/grey cement to be higher for 1990. The share of white cement decreases significantly through the early part of the 1990s causing the IEF to decrease as well. In 1990, 25 % of all cement produced was white cement; in 1991-1997 that same share fluctuates around 21 % (20 % in 1992 to 22 % in 1995). As presented in Table 4.2.3, emission factors are higher for white cement than for grey cement products resulting in a higher IEF for 1990.

Table 4.2.3 Emission factors used for 1990-1997 (Aalborg Portland, 2008).

Product	Value	Unit
White cement	0.669	t CO ₂ /t white cement
GLK clinker	0.477	t CO ₂ /t GLK grey clinker
FKH clinker	0.459	t CO ₂ /t FKH grey clinker
SKL/RKL clinker	0.610	t CO ₂ /t SKL/RKL grey clinker

For the entire time series, the emission factor (carbon content) has been estimated from the loss on ignition determined for the different kinds of clinkers produced (1990-1997) or different raw materials used (1998-2020). Determination of loss on ignition means that there is no need to consider uncalcined cement kiln dust (CKD) not recycled to the kiln; further detail is given above under methodology.

The company reporting to the EU-ETS applies the following emission factors for the most important raw materials used in 2020, similar data are available back to 2006 (Aalborg Portland 2021a) and to a less detailed degree back to 1998 (Aalborg Portland, 2020).

Table 4.2.4 Emission factors for some of the raw materials used in 2020 (Aalborg Portland, 2021a).

Raw material	t CO ₂ per t raw material
Limestone	0.44
Magnesium carbonate	0.522
Ferrous carbonate	0.38
Sand	0.007-0.030
Fly ash	0.100
Desulphurisation gypsum	0.014
Oxiron	0.027

The emission factors for limestone and carbonates are in accordance with the stoichiometric factors and the emission factors for the remaining raw materials and CKD are determined by individual yearly analysis.

Emission trends

The emission trend for the CO₂ emission from cement production is available in Annex 3C-3 and is also presented in Figure 4.2.2 below.

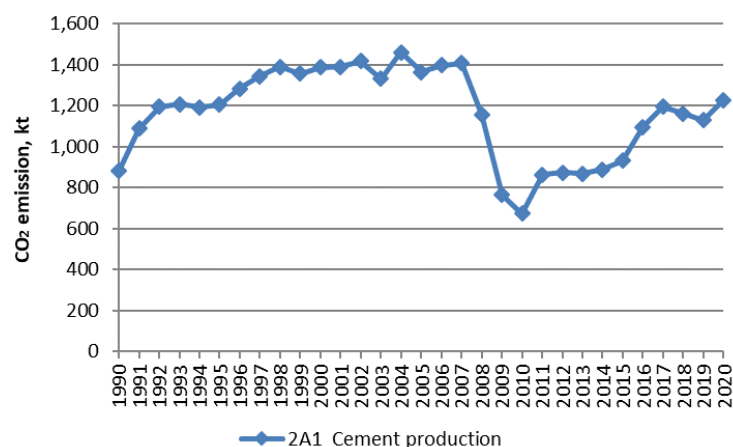

Figure 4.2.2 Emission of CO₂ from cement production.

The increase in CO₂ emission from the production of cement from 1990 to 1997 can be explained by the increase in the annual cement production. The most significant change to occur in the time series is the significant decline in emission from 2007-2010, the decrease is due to reduced production resulting from the economic recession caused by the global financial crisis. The emissions increased 83 % in 2010-2020, but the emissions are still below the pre-recession levels. However, the overall development in the CO₂ emission from 1990 to 2020 is an increase from 882 to 1227 kt CO₂, i.e. by 39.0 %. The maximum emission occurred in 2004 and constituted 1 459 kt CO₂.

Time series consistency and completeness

Since Denmark only has one cement factory, all data collected from the production are plant specific data.

For 1990-1997, activity data for grey cement production fulfil the Tier 2 methodology while activity data for white cement (20-25 % of mass produced) only fulfil the Tier 1 methodology (IPCC, 2006). The company has informed that data until 1997 cannot be improved as there is no further information available. Since 1998, the determination of activity data for cement production has met the requirements of the Tier 3 methodology.

Emission factors have for the entire time series been determined by analysed loss on ignition which fulfil the requirements of the Tier 3 methodology.

Due to extensive verification, the methodology is believed to be consistent. For the various verifications performed, please refer to the IPPU sector report Hjelgaard & Nielsen (2018).

The inventory on cement production is considered complete in accordance with IPCC (2006) as the sole producer of cement in Denmark is fully included.

4.2.4 Lime production

The production of limestone (CaCO₃) and lime/burned lime/quicklime (CaO) is located at a few localities: Faxø Kalk (Lhoist group) situated in Faxø, Scandinavian Calcium Oxide ApS situated in Støvring, Dankalk A/S situated in Løgstør with limestone quarries/limeworks in Aggersund, Mjels, Poulstrup and Batum. In addition to the marketed lime production is the lime production related to production of sugar. Sugar production is concentrated at

one company: Nordic Sugar (previously Danisco Sugar A/S) located in Assens (closed since 2007), Nakskov and Nykøbing Falster. The following SNAP-code is covered:

- 04 06 14 Lime (decarbonising)

Emissions associated with the fuel use are estimated and reported in the energy sector.

Methodology

Calculation of CO₂ emissions from oxidation of carbonates follows the general process:

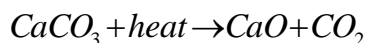

The emission of CO₂ results from heating of the carbonates in the lime-kiln. The lime-kilns can be located either at the location for limestone extraction or at the location for use of burned lime.

The CO₂ emission from the production of marketed burnt lime has been estimated from the annual production figures registered by Statistics Denmark, and emission factors. Since 2006, point source data for Faxe Kalk have been applied, but the total production always sums up to the national statistics. Plant specific activity data for marketed lime from Faxe Kalk are available from EU-ETS since 2006. Faxe Kalk constitutes 22-83% (55 % in average) of the Danish activity in 2006-2020. The plant specific activity data are available back to 1995 from the environmental reports but these are not applied as a point source. Different smaller productions account for the remaining production of marketed lime in Denmark.

Since 2006, process CO₂ emissions from Faxe Kalk have been calculated by the company and reported to EU-ETS and since 2008 Faxe Kalk has measured and included the content of tonnes CO₃ in the process emissions reported to EU-ETS. For the sake of consistency, the same method has been applied for the entire time series and for all producers, i.e. assuming the same CaCO₃/MgCO₃ ratio as the measured average from Faxe Kalk in 2007-2013.

Limestone consumption data for production of sugar are available from the company's environmental reports (Nordic Sugar, 2021; Nordic Sugar Nykøbing, 2010; Nordic Sugar Nakskov, 2012; Danisco Sugar Assens, 2007) back to 1996 and sugar sales statistics are available from Statistics Denmark (2021) for the entire time series. Limestone consumption data are used when available and national sugar sales statistics are used as surrogate data for the remaining years (1990-1995). Raw material consumption data are for 1990-2006 only given in amount of limestone, these data and calculated into amount of burnt lime (CaO) equivalents using the stoichiometric relation between CaCO₃/CaO and the 2007-2013 average measured CaCO₃ content in limestone of 11.62 % (Nordic Sugar Nakskov, 2012 and Nordic Sugar, 2021).

EU-ETS data for lime production

The applied methodology for Faxe Kalk is specified in the individual monitoring plan that is approved by Danish authorities (DEA) prior to the reporting of the emissions. Lime production applies the Tier 2 methodology for the activity data (uncertainty ± 1.0 %) and Tier 3 for the emission factor.

The implied CO₂ emission factor for Faxekalk is plant specific and based on the reporting to the EU Emission Trading Scheme (EU-ETS). The EU-ETS data have been applied for the years 2006 – 2020.

The CO₂ emission for lime production is based on sales ($\pm 1.0\%$) and measurements of the CaO and MgO contents in the product (annual averages of weekly measurements) (Faxekalk, 2013a).

Activity data

The production data for burnt lime are presented in Table 4.2.5 and Annex 3C-4.

Table 4.2.5 Production of burnt lime, kt.

	1990	1995	2000	2005	2010	2015	2017	2018	2019	2020
From Faxekalk ¹	-	-	-	-	25.6	30.1	31.3	29.3	15.9	11.7
From other producers ²	-	-	-	-	24.8	33.4	31.1	15.8	25.5	42.3
From sugar production ³	5.8	5.1	5.8	4.7	2.0	0.7	1.9	1.3	1.3	1.4
Total lime production	133.8	105.9	97.8	75.9	52.4	64.2	64.2	46.4	42.8	55.4

Emission factors

The emission factor for calcination of both marketed and non-marketed calcium carbonate is based on measurements from Faxekalk in 2008-2012; the emission factor applied is 0.788 kg CO₂ per kg CaO, Faxekalk (2021). These measurements include a small impurity of MgO. It is assumed that the degree of calcination is 100% and that no lime kiln dust (LKD) emits from the process.

The implied emission factor for marketed lime production will vary as the measured emission factor for Faxekalk fluctuates, the implied emission factor is between 0.788 kg CO₂ per kg CaO (2017) and 0.793 kg CO₂ per kg CaO (2018).

Emission trends

The trend for the CO₂ emission from lime production, including sugar production; is available in Annex 3C-5 and Figure 4.2.3.

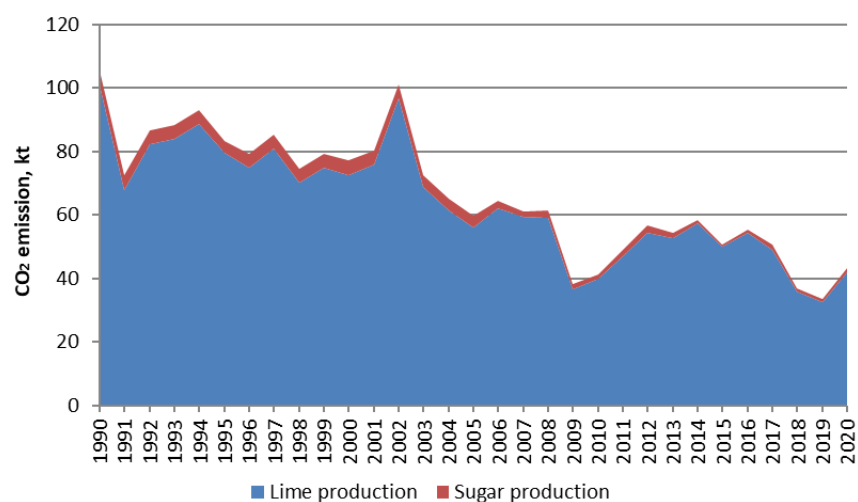

Figure 4.2.3 Emission of CO₂ from lime production.

The emission from sugar production only comprise 1% (2015) to 6% (1991) of the total CO₂ emission from lime production; 4% in average over the time series.

The activity data are based on the official statistics from Statistics Denmark and there is no immediate explanation to the peak in 2002. There are very few producers in Denmark and therefore it will not be possible to obtain more detailed information from Statistics Denmark.

Time series consistency and completeness

The chosen methodology, activity data and emission factor for calculation of CO₂ emissions from marketed lime are consistent throughout the time series.

All though the activity data for non-marketed lime production at the sugar factories are based on actual carbonate consumption from 1996 onward and on estimated consumptions for 1990-1995, the methodology and applied emission factor are both considered to be consistent.

With regards to completeness concerning production of other lime products than burnt lime, dolomitic lime is not produced in Denmark and the production of hydrated lime (slaked lime) from burnt lime does not emit any greenhouse gasses. All burnt lime that is later slaked is included in the statistical data on which the calculations are based, and adding the production of slaked lime to the activity data would therefore result in double counting.

Other industries that typically use lime as an intermediate product are chemical-, metal-, production for emissions abatement etc., these industries have been investigated with respect to completing this source but nothing was found. Regarding industries producing lime as intermediate products only one was identified (i.e. Nordic Sugar). Denmark has virtually no chemical or metal industry, so the need for lime in the Danish industry is non-existing with the exception of the sources listed, and the sector must therefore be complete.

For verification, please refer to Hjelgaard & Nielsen (2018).

4.2.5 Glass production

Glass production in Denmark includes production of:

- Container glass
- Industrial art glass
- Glass wool

The production of container glass for packaging is concentrated at one company; Ardagh Glass Holmegaard A/S (previously Rexam Glass Holmegaard A/S), and the production of art industrial glass products is concentrated at Holmegaard A/S, both companies are situated in Fensmark, Næstved. Saint-Gobain Iover situated in Vamdrup is the only Danish producer of glass wool. The following SNAP-code is covered:

- 04 06 13 Glass (decarbonising)

Emissions associated with the fuel use are estimated and reported in the energy sector.

Methodology

For the production of both container glass, art glass and glass wool, the main raw materials are soda ash (Na₂CO₃), dolomite (CaMg(CO₃)₂), limestone

(CaCO₃) and recycled glass (cullets). Emissions are calculated for each carbonate raw material individually.

Information on consumption of carbon containing raw materials in container- and art glass production is available from the environmental reports for 1997-2013 (Ardagh, 2014) and from EU-ETS since 2006 (Ardagh, 2021). For the years prior to 1997 the production of glass is based on information contained in Illerup et al. (1999). Only one industrial art glass producer with virgin glass production exists in Denmark; Holmegaard A/S. Emissions from this production is included in the data on container glass.

Information on consumption of carbon containing raw materials in glass wool production is available from the environmental reports of the plant for 1996-2014 (Saint-Gobain Isover, 2015) and from EU-ETS since 2006 (Saint-Gobain Isover, 2021). For the years prior to 1996 the production of glass wool and consumption of carbonates are estimated.

EU-ETS data for glass production

The applied methodologies for Ardagh Glass Holmegaard and Saint-Gobain Isover are specified in the individual monitoring plan that is approved by Danish authorities (DEA) prior to the reporting of the emissions.

Glass production applies the Tier 3 for both methodology and emission factors as the calculations are based on individual carbonates used as raw materials.

The CO₂ emission from container/art glass production is based on consumption of carbonate raw materials (based on invoices and corrected for changes in inventory by measures on the storage silos; Tier 2: 1.10-1.37% depending on the silo) and standard emission factors except for dolomite where Ca/Mg analysis are performed for each new batch (Ardagh, 2012).

The CO₂ emission from glass wool production is based on weight measures of carbonate raw materials (Tier 1: ±2.5%) and standard emission factors (Saint-Gobain Isover, 2012).

Activity data

The activity data for container/art glass production are presented in Table 4.2.6 and Annex 3C-6.

Table 4.2.6 Production of container/art glass, activity data, kt.

	1990	1995	2000	2005	2010	2015	2017	2018	2019	2020
Production of glass ^{1,2}	164.0	140.0	183.3	168.2	172.9	155.7	149.5	156.2	158.1	140.4
Consumption of soda ash ^{3,4}	17.8	15.2	16.4	13.0	c	c	c	c	c	c
Consumption of limestone ^{3,4}	14.4	12.3	7.7	5.7	c	c	c	c	c	c
Consumption of dolomite ^{3,4}	1.0	0.8	9.1	6.1	c	c	c	c	c	c

¹ 1990-1997: Illerup et al. (1999).

² 1998-2016: Estimated based on Illerup et al. (1999) and consumption of raw materials.

³ 1990-1996: Estimated based on Illerup et al. (1999) and the consumption of raw materials in 1997.

⁴ 1997-2017: Environmental reports and EU-ETS data; Ardagh (2014, 2021).

c Confidential: data from EU-ETS (Ardagh, 2021).

The activity data for glass wool production are presented in Table 4.2.7 and Annex 3C-7.

Table 4.2.7 Production of glass wool, activity data, kt.

	1990	1995	2000	2005	2010	2015	2017	2018	2019	2020
Production of glass wool ¹	35.6	35.6	39.7	37.3	24.9	33.0	38.3	43.5	44.6	42.1
Consumption of soda ash ^{2, 4}	3.6	3.6	3.0	3.6	c	c	c	c	c	c
Consumption of limestone ^{2, 4}	0.8	0.8	0.2	0.6	c	c	c	c	c	c
Consumption of dolomite ³	1.0	1.0	1.0	1.0	c	c	c	c	c	c

¹ 1990-1996: Estimated: Assumed constant on the average production from 1997-1999.

² 1990-1995: Estimated: Assumed constant on the average consumption from 1996-1998.

³ 1990-2005: Estimated: Assumed constant on the average consumption from 2006-2008.

⁴ 1996-2005: Environmental reports (Saint-Gobain Isover, 2015).

c Confidential: data from EU-ETS (Saint-Gobain Isover, 2021).

Emission factors

The CO₂ emission factors from using soda ash and other carbonate containing raw materials in production of virgin glass and glass wool, based on stoichiometric relationships, are:

- 0.41492 t CO₂/t Na₂CO₃
- 0.43971 t CO₂/t CaCO₃
- 0.473-0.517 t CO₂/t CaMg(CO₃)₂

The emission factor for dolomite is 0.478 tonnes CO₂ per tonne for glass wool production and 0.477 tonnes CO₂ per tonne for container/art glass production in 2020. The average emission factor for dolomite in container glass production is 0.493 tonnes CO₂ per tonne dolomite for 2008-2020. The calcination of all carbonates in all years is assumed to be 100 %.

From 2006 onward the CO₂ emissions are calculated by the companies and reported to EU-ETS (Ardagh, 2021; Saint-Gobain Isover, 2021), but the applied emission factors remain the same for the entire time series.

Emission trends

For the years from 2006 onward, where EU-ETS data are applied, information is confidential and therefore not presented individually for container/art glass and glass wool production.

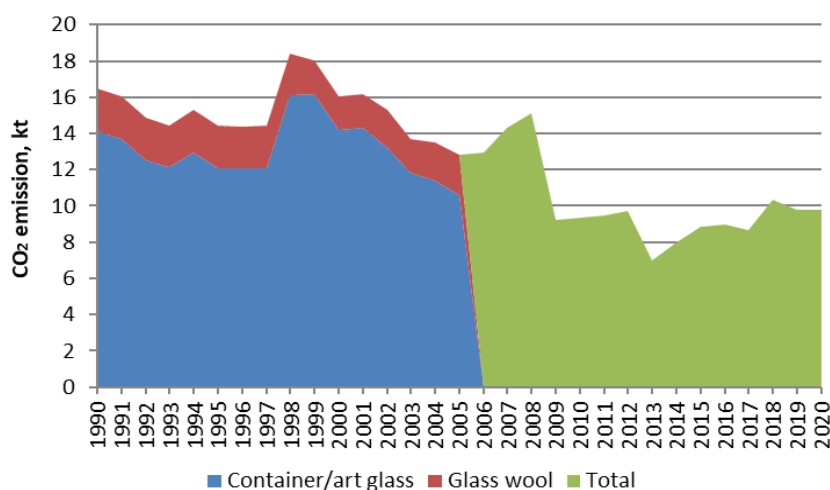

Figure 4.2.4 CO₂ emissions from glass and glass wool production.

Time series consistency and completeness

CO₂ emissions from container/art glass and glass wool production are calculated based on consumption of carbonates and stoichiometric emission factors for the entire time series, the time series is therefore consistent.

In relation to completeness, the production of flat glass (SNAP 03 03 14 Flat glass) does not occur in Denmark. The processes in Denmark are limited to mounting of sealed glazing units. The mounting process does not contribute to greenhouse gas emissions in Denmark.

An effort has been made to ensure that all glass producers are included in the inventory. Smaller facilities producing art glass do exist in Denmark, but none of these were found to produce their own virgin glass. The source category of glass production is therefore considered to be complete.

For verification, please refer to Hjelgaard & Nielsen (2018).

4.2.6 Ceramics

This section covers production of bricks, tiles (aggregates or bricks/blocks for construction) and expanded clay products for different purposes (aggregates as absorbent for chemicals, cat litter, and for other miscellaneous purposes). The following SNAP codes are covered:

- 04 06 91 Production of bricks
- 04 06 92 Production of expanded clay products

The production of bricks (and tiles) is found all over the country, where clay is available. Producers of expanded clay products are located in the northern part of Jutland.

Emissions associated with the fuel use are estimated and reported in the energy sector.

Methodology

Emission of CO₂ is related to the content of carbon bearing material in the clay. The emission estimation is based on the total carbon content of the raw material. Since 2006, the producers of ceramics have measured and reported process CO₂ emissions to EU-ETS and production statistics are known from Statistics Denmark (2021) for the entire time series. From these two datasets, implied emission factors (i.e. t CaCO₃ per t product) are calculated for 2006-2013 and emissions are calculated for the years back to 1990.

EU-ETS data for ceramics

The applied methodologies for brickworks and expanded clay producers are specified in the individual monitoring plans that are approved by Danish authorities (DEA) prior to the reporting of the emissions. The production of ceramics applies the ETS Tier 2 methodology for calculating the CO₂ emission.

The CO₂ emission for ceramics production is based on measured carbonate content in all raw materials and consumption of the individual carbonate containing raw materials (Tier 2; ± 5.0 %). The implied CO₂ emission factors for the production facilities are based on stoichiometry and 100 % calcination is assumed.

Activity data

National statistics on bricks, tiles and expanded clay contain a broad range of different products, most of them in units of numbers (no.). The consumption of limestone is therefore used as activity data for these source categories; available for 2006-2020 and calculated for 1990-2005. The national statistics are used as surrogate data; available for 1985-2020. Data on consumption of lime

and produced amounts of ceramics are presented in Table 4.2.8 and Annex 3C-8.

Table 4.2.8 Statistics for production of bricks/tiles and expanded clay products.

		1990	1995	2000	2005	2010	2015	2017	2018	2019	2020
Bricks and tiles											
Produced ¹	million pieces	315.2	385.6	436.3	426.5	223.0	226.7	280.9	286.8	288.1	311.9
Consumed lime ²	kt CaCO ₃	58.6	71.7	81.1	79.2	35.1	46.2	63.3	67.0	64.3	61.1
Expanded clay products											
Produced ¹	kt	331.8	340.9	316.2	310.9	157.4	155.0	183.0	185.7	219.8	247.6
Consumed lime ²	kt CaCO ₃ eqv	46.2	47.5	44.0	43.3	19.1	19.5	32.0	38.4	41.7	37.5

¹ Statistics Denmark (2021).

² 1990-2005: Calculated from production data and the average implied emission factor for 2006-2013.

Both the brickworks and expanded clay productions displays a significant decrease from 2007 to 2009 that can be explained by the global financial crises. The decreases correspond to 59 % and 71 % respectively for brickworks and expanded clay production. The number of brickworks have been decreasing; in 2006 19 brickworks reported to EU-ETS, by 2014 this number had decreased to 13. Two brickworks closed down in 2008, further two in 2009 and another two in 2013.

Emission factors

The emission factor for lime is 0.43971 kg CO₂ per kg CaCO₃. The calcination factor is assumed to be 100 % for all years and all producers.

Since 2006, CO₂ emissions are reported by the brickworks to EU-ETS (confidential reports). The reported emissions are calculated from measured lime contents of the raw materials and the stoichiometric emission factor 0.43971 kg CO₂ per kg CaCO₃.

Producers of expanded clay products also report CO₂ emissions to EU-ETS for the years since 2006 (Imerys, 2021; Leca, 2021). The reported emissions are calculated from the difference in C contents measured in the raw materials and products and the stoichiometric emission factor 3.664 kg CO₂ per kg C. The reported emissions are recalculated to match the activity data for brickworks using the stoichiometric factors.

Emission trends

The emission trends for the CO₂ emission from production of bricks/tiles and expanded clay products are available in Annex 3C-9 but is also presented in Figure 4.2.5.

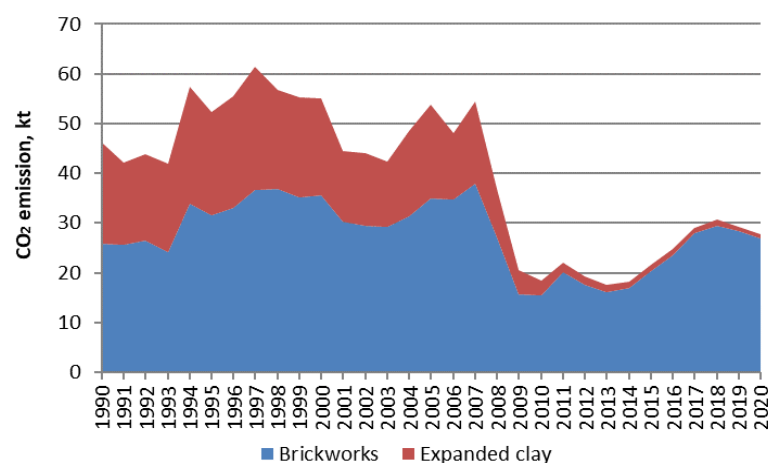

Figure 4.2.5 CO₂ emissions from the production of ceramics.

Emissions from this source category are very dependent on new houses being built as well as old ones being renovated. The significant decline in emissions from 2007-2009 was caused by a reduced production resulting from the economic recession caused by the global financial crisis.

Time series consistency and completeness

Emissions from 2006 onwards are known from the EU-ETS reports and emissions for 1990-2005 are estimated. However, due to the various performed verifications (Hjelgaard & Nielsen, 2018), the ceramics source category is considered to be consistent.

The inventory is based on companies reporting to EU-ETS and national sales statistics, but clay is also burned in minor scale e.g. ceramic art workshops and school art classes. These miniscule sources are however negligible and the source category of ceramics is considered to be complete.

4.2.7 Other uses of soda ash

This section covers the use of soda ash not related to glass production. The following SNAP code is covered:

- 04 06 19 Other uses of soda ash

Methodology

Emissions from other uses of soda ash (Na_2CO_3) are calculated based on national statistics on import/export (subtracted the amount used in the glass industry) and the stoichiometric emission factor. No information is available on the end uses of soda ash and therefore all use is considered to be emissive.

Activity data

National statistics on import/export and the calculated activity data (supply) are presented in Table 4.2.9 and Annex 3C-10.

Table 4.2.9 Statistics for other uses of soda ash, kt.

	1990	1995	2000	2005	2010	2015	2017	2018	2019	2020
Import	54.6	47.6	42.0	59.5	36.5	26.3	47.7	50.4	51.4	51.8
Export	0.09	2.13	0.31	0.01	0.06	0.07	0.17	0.14	0.27	0.22
Glass production	21.4	18.8	19.4	16.6	10.7	8.6	8.9	10.9	9.9	9.8
Supply	33.2	26.7	22.3	42.9	25.7	17.6	38.6	39.3	41.2	41.8

Emission factors

The applied emission factor for other uses of soda ash is 414.92 kg CO_2 per tonne Na_2CO_3 . The calculation assumes a calcination factor of 100 %.

Emission trends

The emission trend for the CO_2 emission from other uses of soda ash is available in Figure 4.2.6 and Annex 3C-11.

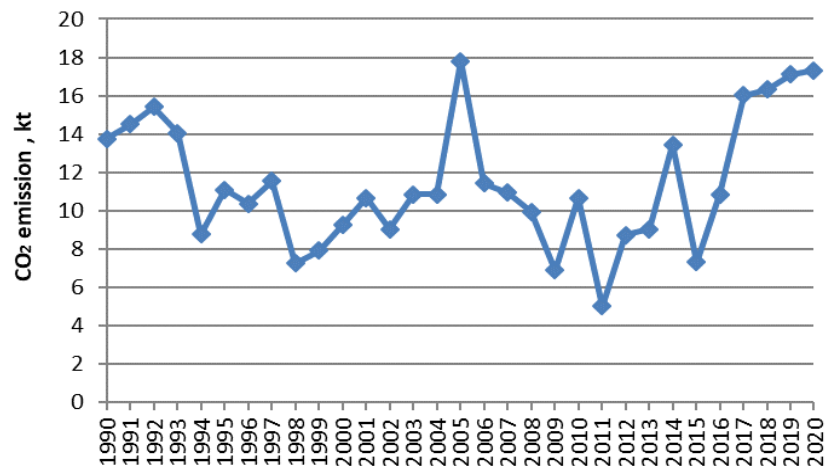

Figure 4.2.6 CO₂ emissions from other uses of soda ash.

Information on the uses of soda ash outside the glass industry is scarce, and descriptions of the trend development are therefore not available.

Time series consistency and completeness

The same methodology is used for calculating emissions for the entire time series, the emissions from other uses of soda ash are therefore consistent. Calculations are based on national import/export statistics and are therefore also complete as there is no production of soda ash in Denmark.

For verification, please refer to Hjelgaard & Nielsen (2018).

4.2.8 Flue gas desulphurisation

Flue gas cleaning systems utilising different technologies are primarily present at major combustion plants i.e. power plants, combined heat and power plants as well as waste incineration plants. The following SNAP code is covered:

- 04 06 18 Limestone and dolomite use - Flue gas cleaning, wet, power plants and waste incineration plants

Methodology

The emission of CO₂ from wet flue gas desulphurisation can be calculated from the following equation:

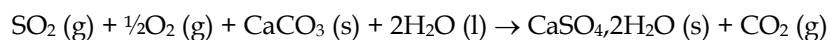

The consumed amount of limestone (CaCO₃) is used as activity data. Information on limestone consumption is available from EU-ETS for 2006 forward.

Energinet.dk compile environmental information related to energy transformation and distribution. Since the waste incineration plants with desulphurisation are all power producers, these plants are also included in the data from Energinet.dk (2020). Statistics on the generation of gypsum are available from Energinet.dk (2020) for 1990-2017. However, for 2006-2020 information on consumption of limestone at the relevant power plants and waste incineration plants has been compiled from EU-ETS and used in the calculation of CO₂ emission from flue gas cleaning. For 1990-2005, the generation of gypsum data have been used as surrogate data.

The consumption of other carbonates than limestone (e.g. TASP¹) is measured by the individual power plants and is added to the limestone consumption in CaCO₃ equivalents.

EU-ETS data for flue gas desulphurisation

The applied methodologies for flue gas desulphurisation are specified in the individual monitoring plans that are approved by Danish authorities (DEA) prior to the reporting of the emissions. The flue gas desulphurisation applies the Tier 1-2 methodology for calculating the CO₂ emission depending on the individual units.

The CO₂ emission for flue gas desulphurisation is based on measured lime consumption ($\pm 1.5\%$ to $\pm 7.5\%$). The implied CO₂ emission factors for the production facilities are based on stoichiometry.

Since 2013, seven of the 12 waste incineration plants operating wet flue gas cleaning, have applied a reporting method based on measurements. This means that these plants now estimate the total emissions (process and energy related as one), and that process emissions from these plants are therefore reported under the energy sector.

Activity data

During the time series this source has increased due to more plants being fitted with desulphurisation (1990-1999). However, since the main use is in coal fired plants, flue gas desulphurisation is decreasing as some of the coal fired power plants are rebuilt to combust biomass and the need for flue gas desulphurisation ceases. Since 2006, five of the nine coal fired power plants have changed to alternative fuels and desulphurisation has ceased from these plants.

The Danish waste incineration plants are in general smaller than the coal combustion facilities and owned by smaller companies. Of the approximately 30 waste incineration plants with flue gas desulphurisation only one third uses wet flue gas cleaning.

The activity data are presented in Table 4.2.10, Figure 4.2.7 and Annex 3C-12.

Table 4.2.10 Activity data for flue gas desulphurisation, kt.

	1990	1995	2000	2005	2010	2015	2017	2018	2019	2020
Gypsum production ¹	41.6	211.5	354.3	220.4	179.7	91.7	76.6	NAV	NAV	NAV
CaCO ₃ consumption ^{2,3}	22.0	111.8	187.3	116.6	95.6	35.3	33.0	34.4	21.0	17.0

¹ Energinet.dk (2020).

² 1990-2005: Estimated from surrogate data and stoichiometric relations.

³ 2006-2020: EU-ETS of the individual plants.

NAV: Not Available.

¹ "Tørt AfSvovlingsProdukt" (Dry desulphurisation product), the by-product from dry flue gas desulphurisation processes.

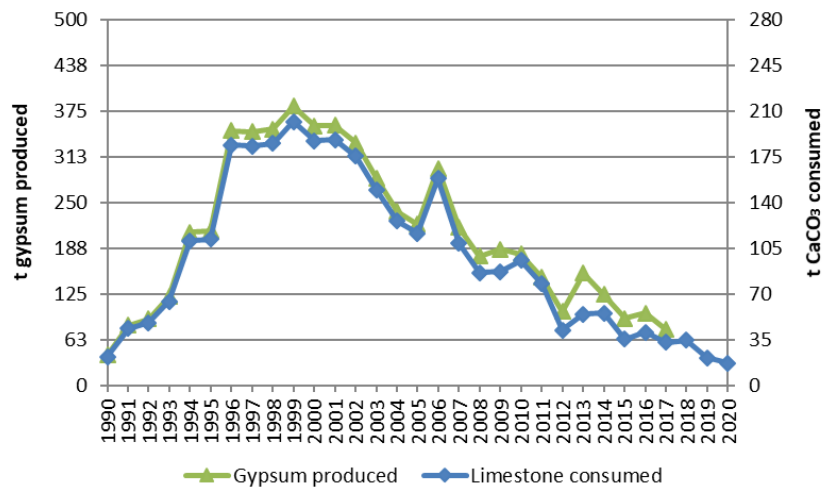

Figure 4.2.7 Activity data for flue gas desulphurisation.

The activity data level varies with the coal consumption that again varies greatly with electricity import/export. And as mentioned above, part of the decreasing trend in this category is caused by the allocation of emissions from some waste incineration plants to the energy sector.

Emission factors

The emission factor applied to the limestone consumption is the stoichiometric emission factor 0.43971 tonnes CO₂ per tonne CaCO₃.

Emission trends

The emission trend for the CO₂ emission from flue gas desulphurisation is available in Table 4.2.11 and Annex 3C-13.

Table 4.2.11 CO₂ emissions from flue gas desulphurisation, kt.

	1990	1995	2000	2005	2010	2015	2017	2018	2019	2020
Flue gas desulphurisation	9.7	49.2	82.4	51.2	42.0	15.5	14.5	15.1	9.2	7.5

Time series consistency and completeness

The methodology for calculating emission from flue gas desulphurisation is consistent in spite of varying methods; please refer to the verification presented in Hjelgaard & Nielsen (2018). The source category is considered to be complete.

4.2.9 Stone wool production

Only one company produces stone wool in Denmark, Rockwool situated at three localities: Hedehusene², Vamdrup and Øster Doense. The following SNAP-code is covered:

- 04 06 18 Limestone and dolomite use – Stone wool production

Emissions associated with the fuel use are estimated and reported in the energy sector.

Methodology

Stone wool is produced from mineral fibres and a binder. The raw materials are melted in a cupola fired by coke and natural gas, several raw materials contribute to the process CO₂ emission e.g. bottom ash, limestone, dolomite,

² The melting of minerals (cupola) has closed down in 2002.

binder etc.. The consumption of raw material as well as amount of produced stone wool is confidential.

Information on emissions from 2006-2020 has in combination with annual production data and raw material consumption data been used to extrapolate the emissions back to 1995. The data have been extracted from company reports (Rockwool, 2014a) and EU-ETS (Rockwool, 2021). CO₂ process emissions are available for the years 2006-2020 (EU-ETS), the consumption of raw materials for 1995-2013 (environmental reports) and production data for 1995-2004 and 2014-2020 (Statistics Denmark and EU-ETS). Emissions for 1990-1994 are estimated as the constant average of 1995-1999.

Calculations are performed for the three factories individually.

EU-ETS data for stone wool production

Stone wool production applies the ETS Tier 3 methodology for calculating the CO₂ process emission for 2006 onwards.

The implied CO₂ emission factor for Rockwool is plant specific and based on the reporting to the EU-ETS. The EU-ETS data have been applied for the years 2006 onwards.

The CO₂ emission for stone wool production is based on measurements of the consumption of carbonates. These measurements fulfil an ETS Tier 1 or Tier 3 methodology ($\pm 1.6 - 5.0 \%$) depending on the carbonate. The emission factors are based on carbon content measurements for each carbonate (ETS Tier 2-3). (Rockwool, 2014b).

Activity data

The consumption of limestone equivalents are presented in Table 4.2.12 and Annex 3C-14.

Table 4.2.12 Activity data for stone wool production, kt CaCO₃ equivalents.

	1990	1995	2000	2005	2010	2015	2017	2018	2019	2020
Carbonate consumption	16.7	13.5	16.7	18.0	17.1	13.5	18.2	25.0	9.6	12.0

Emission factors

The applied emission factor for stone wool production is the stoichiometric factor 0.43971 tonnes CO₂ per tonne CaCO₃.

Emission trends

The emission trend for the CO₂ emission from stone wool production is presented in Figure 4.2.8 below and Annex 3C-15.

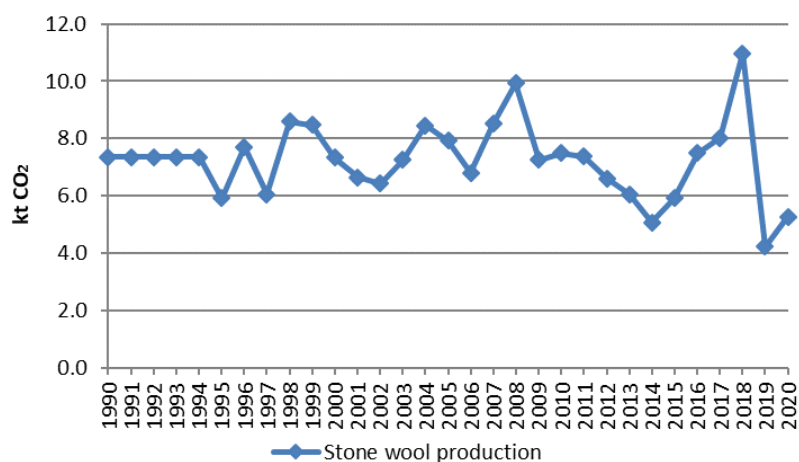

Figure 4.2.8 CO₂ emissions from stone wool production.

The consumption of CO₂ emitting raw materials in stone wool production varies, and so does the carbon content of the waste used as raw material. The strong decrease in emissions from 2018 to 2019 is due to a strong decrease in use of dolomite as raw material. Rockwool strides to reduce CO₂ process emissions from production of stone wool by reducing the consumption of dolomite, but the decrease must also be seen as naturally occurring variation in raw material composition.

Time series consistency and completeness

The source category of stone wool production is complete. Emissions for 2006 onward are known (EU-ETS) but emissions for 1990-2005 are estimated via surrogate data, in spite of this change in method the source category is considered to be consistent.

4.3 Chemical Industry

4.3.1 Source category description

The sector *Chemical industry* (2B) covers the following industries relevant for the Danish air emission inventory:

- 2B2 Nitric acid production (SNAP 040402); see section 4.4.3.
- 2B10 Catalyst production (SNAP 040416); see section 4.4.4.

Nitric acid production is identified as a key category in 1990 according to both Approach 1 and Approach 2. The trend is also identified as key category according to both Approach 1 and Approach 2, however this is due to the closing of the lone plant producing nitric acid in Denmark in 2004.

4.3.2 Emissions

Total greenhouse gas emissions from the Chemical Industry sector are available in the CRF Table 10. The emission time series for the source categories within *Chemical Industry* (2B) are presented in Figure 4.3.1 and individually in the subsections below (Sections 4.4.3 – 4.2.4). The following figure gives an overview of which source categories contribute the most throughout the time series.

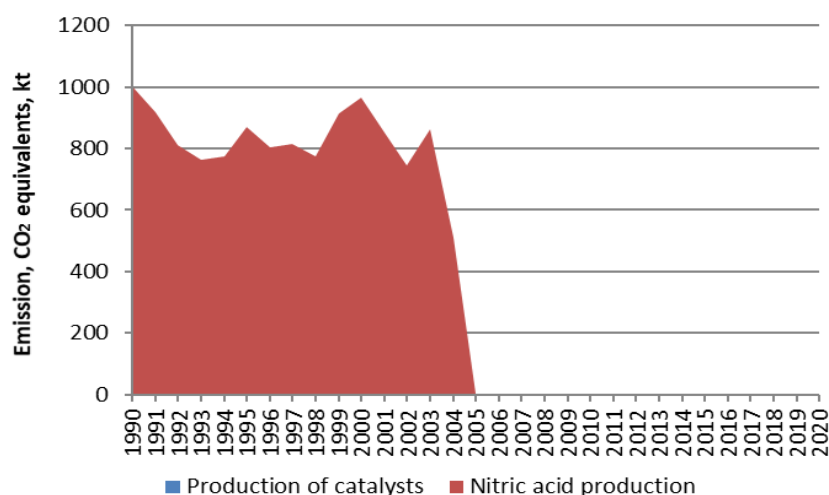

Figure 4.3.1 Emission of CO₂ equivalents from the individual source categories compiling 2B Chemical Industry, kt.

Greenhouse gas emissions from *Chemical Industry* are made up almost entirely by N₂O emissions from the production of nitric acid; only 0.1 % (1990-2003) to 0.2 % (2004) stems from the production of catalysts, making the emission invisible in the figure above. The production of nitric acid ceased in the middle of 2004.

4.3.3 Nitric acid production

The production of nitric acid as well as NPK fertilisers has been concentrated at one company: Kemira GrowHow A/S situated in Fredericia. The production ceased in the summer of 2004. The following SNAP code is covered:

- 04 04 02 Nitric acid

Methodology

The information on the N₂O emissions from the production of nitric acid/fertiliser is obtained from environmental reports (Kemira GrowHow, 2005), contact to the company as well as information from the county. Information on emissions of N₂O is available for 2002. For the remaining years the N₂O emission has been estimated from annual production statistics from the company and an implied emission factor based on 2002.

Specific information on applied technology is not available; however, the emission factor measured by the Danish nitric acid plant is comparable with the default emission factor for a medium pressure plant (IPCC, 2006).

The production of nitric acid in Denmark ceased in the middle of 2004 and the company relocated the production to a more modern facility in another country.

Activity data

The applied activity data for production of nitric acid are presented in Table 4.3.1 and Annex 3C-16.

Table 4.3.1 Production of nitric acid, kt.

	1990	1995	2000	2004
Nitric acid	450	390	433	229

In the time series, the production of nitric acid peaked in 1990 with 450 kt (and 807 kt fertiliser) and then fluctuated around the average of 375 kt nitric acid

(694 kt fertiliser) from 1990-2003 until the factory closed down in the summer of 2004; 2004 production of 229 kt nitric acid and 395 kt fertiliser (Kemira GrowHow, 2005).

Emission factors

Default emission factors given by IPCC (2006³) are presented in Table 4.3.2 together with the Danish value.

Table 4.3.2 Emission factors for production of nitric acid in Denmark compared with default emission factors (IPCC, 2006) (kg per t nitric acid).

	Danish IEF 2002	Default EF
N ₂ O	7.476	2-2.5 ¹ 5 ² 7 ³ 9 ⁴

¹ Modern, NSCR, process-integrated or tailgas N₂O destruction.

² Atmospheric pressure plant (low pressure).

³ Medium pressure combustion plants.

⁴ High pressure plants.

Emission trends

The emission trend for the N₂O emission from nitric acid production is available in Figure 4.3.1 and Annex 3C-17.

The trend for N₂O emission from 1990 to 2003 shows a decrease from 3.4 to 2.9 kt, i.e. 14 %, and a 41 % decrease from 2003 to 2004. However, the activity and the corresponding emission show considerable fluctuations in the period considered and the decrease from 2003 to 2004 can be explained by the closing of the plant in the middle of 2004.

Time series consistency and completeness

The applied methodology regarding N₂O is consistent. The activity data are based on information from the specific company/plant. The emission factor applied has been constant for the whole time series and is based on measurements performed in 2002. The production equipment has not been changed during the period. The source category of nitric acid production is complete.

4.3.4 Catalyst production

Production of a wide range of catalysts and potassium nitrate (fertiliser) is concentrated at one company: Haldor Topsøe A/S situated in Frederikssund. The following SNAP code is covered:

- 04 04 16 Other: catalysts

Methodology

The applied methodology corresponds to a country-specific (Tier 3) methodology according to the 2006 IPCC Guidelines.

The processes involve carbonate compounds i.e. the process leads to emissions of CO₂. The company has estimated the emission of CO₂ from known emission factors for incineration of natural gas and LPG and from information on the raw materials containing carbonate. The contribution from carbonate compounds is estimated to be the difference between the total CO₂ emission reported in the environmental reports and PRTR (Haldor Topsøe, 2013 and

³ Volume 3 Chemical Industry, Chapter 3.3.2.2 page 3.23 (Table 3.3).

2021b) and the CO₂ emission from energy consumption reported in the environmental reports and to EU-ETS (Haldor Topsøe, 2013 and 2021a). An average implied emission factor (IEF) was calculated for 2003-2009 using this method, this IEF was used for the entire time series. For the years 1990-1995, the production (activity data) is estimated using linear regression on the years 1997-2012.

Activity data

Table 4.3.3 Source of activity data.

Years	Determined by
1990-1995	Linear regression of 1997-2012
1996	Total production is available, the average split between the two products from 1997-2001 is applied for estimating the individual productions
1997-2012	Information from the company (environmental reports)
2013-2014	Estimated using the consumption of raw materials as surrogate data
2015-2020	Estimated using the production data for catalysts from Statistics Denmark and extrapolated production data for potassium nitrate

The activity data regarding production of catalysts and fertiliser are obtained through environmental reports from Haldor Topsøe (2013) where these are available (2007-2012). For years where environmental reports are not available, production data are estimated using the drivers mentioned in Table 4.3.3. Production data are presented in Table 4.3.4 and Annex 3C-18, the annex also includes the applied surrogate data.

Table 4.3.4 Production of catalysts and potassium nitrate, kt.

	1990	1995	2000	2005	2010	2015	2017	2018	2019	2020
Catalysts produced	-	-	17.2	23.2	20.5	27.2	27.2	29.7	29.4	27.3
Potassium nitrate produced	-	-	19.2	23.3	25.9	35.2	29.6	30.1	32.5	32.2
Total produced	23.7	30.5	36.4	46.5	46.4	62.4	56.8	59.8	61.9	59.5

Emission factors

The average calculated implied emission factor for 2003-2009 is 0.0241 tonnes CO₂ per tonne product; this factor is applied for the entire time series.

Emission trends

From 1990 to 2020, the emission of CO₂ from the production of catalysts/fertilisers has increased from 0.57 to 1.43 kt (151 %) with maximum in 2015 (1.50 kt), due to an increase in the production as well as changes in raw material consumption.

The trend for the CO₂ emission from the production of catalysts and fertilisers is presented in Annex 3C-19 and in Figure 4.3.2.

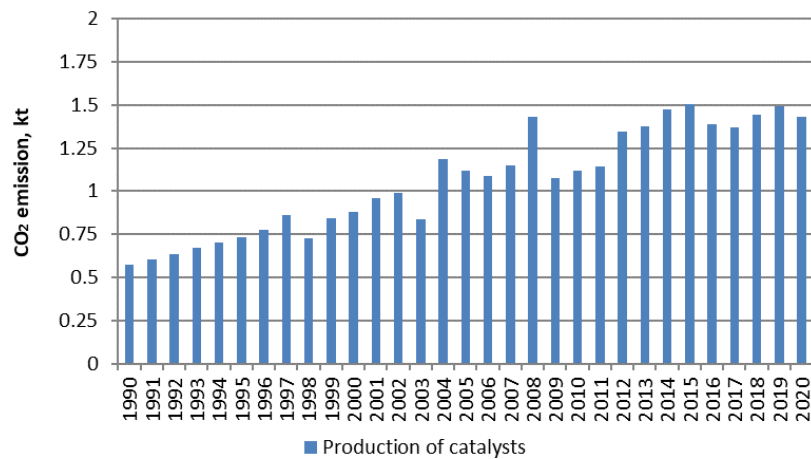

Figure 4.3.2 Emission of CO₂ from catalyst/fertiliser production, kt.

Time series consistency and completeness

There is a change in the applied methodology from 1990-1995 and 1996-onward. Linear regression is used to estimate emissions for 1990-1995, while CO₂ emissions have been provided from the company since 1996. However, the source category is considered to be consistent.

The source category of catalyst production is complete.

4.4 Metal industry

4.4.1 Source category description

The sector *Metal Industry* (CRF 2C) covers the following industries relevant for the Danish air emission inventory:

- 2C1 Iron and steel production (SNAP 040207, 040208); see section 4.4.3
- 2C4 Magnesium production (SNAP 040304); see section 4.4.4
- 2C5 Secondary lead production (SNAP 030307); see section 4.4.5

4.4.2 Emissions

The time series for emission of greenhouse gasses from *Metal Industry* (2C) is presented in the CRF tables and in Figure 4.4.1 below.

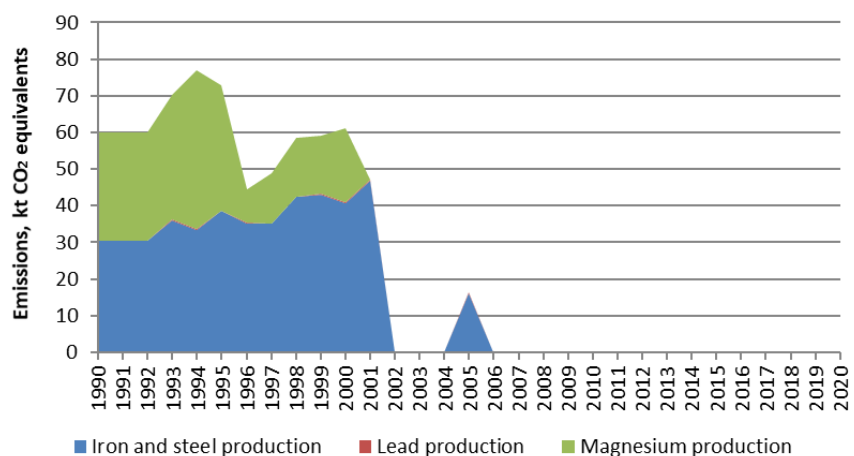

Figure 4.4.1 Emission of greenhouse gasses from the individual source categories compiling 2C *Metal Industry*, kt CO₂ equivalents.

From 1990 to 2001, the CO₂ emission from the electro-steelwork increased by 55 % while the SF₆ emission from magnesium production decreased with 31

% (1990-2000). The changes in the greenhouse gas emission is similar to the increase and decrease in the activity as the consumption of metallurgical coke per amount of steel sheets and bars produced has almost been constant during the period and the emission factor for magnesium production is constant throughout the time series.

Emissions from secondary lead production are miniscule (0.3 % of CO₂ equivalent emissions for 1990-2000), but are the only emissions in the *Metal Industry* sector that occur for the entire time series.

The electro-steelwork was shut down in January 2002 and reopened and closed down again in 2005. In 2000, the SF₆ emission from the magnesium production ceased.

Grey iron foundries are active for the entire time series. But this production does not result in any greenhouse gas emissions in the industry sector.

4.4.3 Iron and steel production

The production of semi-manufactured steel products (e.g. steel sheets/plates and bars) was concentrated at one company: Det Danske Stålvalseværk A/S situated in Frederiksværk. After the closure of the electro steelwork in 2002 the two rolling mills were divided in two companies called DanSteel and Duferco, these are both still in operation but are not included here, as they do not emit process greenhouse gas emissions. The following SNAP code is covered:

- 04 02 07 Electric furnace steel plant

The steelwork was closed down in January 2002 and then partly reopened in November 2002. The production of steel sheets/plates was reopened by DanSteel in 2003, the production of steel bars was reopened by DanScan Metal in March 2004, and the electro steelwork was reopened by DanScan Steel in January 2005. The production at DanScan Metal and Steel ceased in the last part of 2005 and in June 2006 DanScan Metal was taken over by Duferco; the electro steelwork (DanScan Steel) has still not been in operation since 2005. The timeline is presented in Figure 4.4.2.

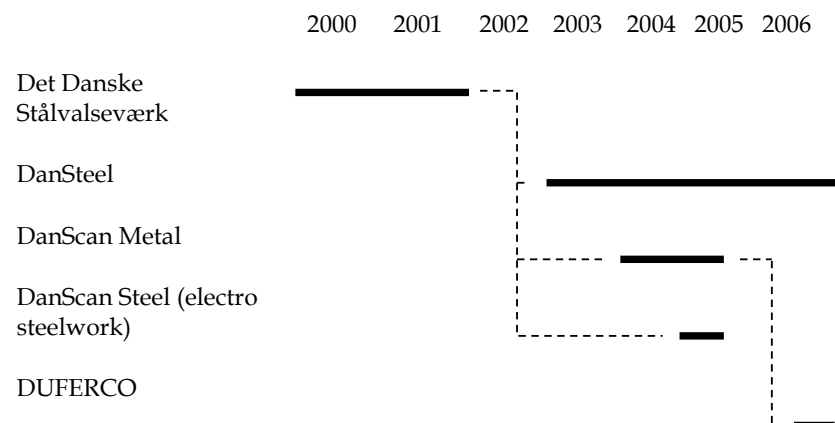
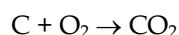

Figure 4.4.2 Timeline for production at the Danish steelwork.

Methodology

Metallurgical coke is used in the melting process to reduce iron oxides and to remove impurities. The overall process is:



The CO₂ emission from the consumption of metallurgical coke at steelworks has been estimated from the annual production of steel sheets and steel bars combined with the consumption of metallurgical coke per produced amount (Stålvalseværket, 2002). The carbon source is assumed to be coke and all the carbon is assumed to be converted to CO₂ as the carbon content in the products is assumed to be the same as in the iron scrap. The emission factor (consumption of metallurgical coke per tonne of product) has been almost constant from 1993 to 2001; steel sheets: 0.012-0.018 tonnes metallurgical coke per tonne and steel bars: 0.011-0.017 tonnes metallurgical coke per tonne.

Production data for 1990-1991 and for 1993 have been determined with extrapolation and interpolation, respectively and data on the consumption of metallurgical coke for 1990-1992 have been extrapolated.

Activity data

Statistical data on steel production activities, i.e. amount of steel sheets and bars produced as well as consumption of metallurgical coke are available in environmental reports from the single Danish steel plant (Stålvalseværket, 2002) supplemented with other literature. In 2002, production stopped. For 2005 the production has been assumed to be one third of the production in 2001 as the steelwork was operating between 4 and 6 months in 2005. The activity data are presented in Table 4.4.1 and Annex 3C-20.

Table 4.4.1 Overall mass flow for Danish steel production, kt.

		1990	1995	2000	2005
Det Danske Stålvalseværk					
Raw material	Iron and steel scrap	-	657	731	-
Intermediate product	Steel slabs etc.	-	654	803	-
Product	Steel sheets	444 ¹	478	380	-
	Steel bars	170 ¹	239	251	-
	Products, total	614 ¹	717	631	250 ²
Raw material	Metallurgical coke	8.3	10.5	11.1	4.4

¹Extrapolation, ²Assumed.

The mass balances/flow sheets presented in the annual environmental reports do not for all years tell about the changes in the stock and therefore the balance cannot be completed.

Emission factors

The emission factors for carbon dioxide from using metallurgical coke in manufacturing of iron and steel from scrap is the stoichiometric ratio 3.667 tonnes CO₂ per tonne C.

Emission trends

The greenhouse gas emissions from the steel production are presented in Figure 4.4.3 and Annex 3C-21. The production ceased in 2001 and reopened and closed again in 2005; see Figure 4.4.2.

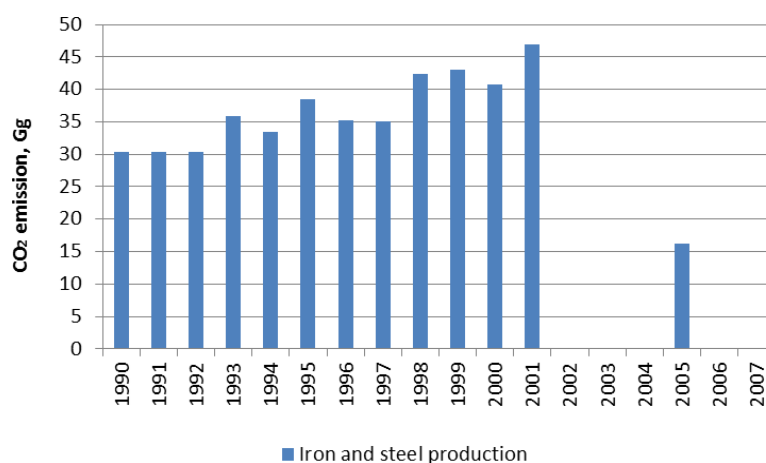

Figure 4.4.3 Emission of greenhouse gases from the production of steel from scrap.

Time series consistency and completeness

The time series for secondary steel production is consistent as the same methodology has been applied for the whole period. The time series is also considered to be complete.

There is no metallurgical coke production in Denmark.

4.4.4 Magnesium production

For the production of magnesium in Denmark the following SNAP-code is covered:

- 04 03 04 Consumption of SF₆ in magnesium foundries

Methodology

The consumption of SF₆ in the magnesium production is known from information directly from the industry (Poulsen, 2022). The emission can be calculated from the SF₆ consumption and the default Tier 1 emission factor, which is a release of 100 %.

Activity data

Table 4.4.2 presents the activity data.

Table 4.4.2 Production of magnesium, tonnes.

	1990	1991	1992	1993	1994	1995	1996	1997	1998	1999	2000
Magnesium produced	1300	1300	1300	1500	1900	1500	400	600	700	700	891

Emission factors

The applied emission factor is 1, i.e. 100 % release of SF₆ used.

Emission trends

The greenhouse gas emissions from the production of magnesium are presented in Figure 4.4.4 below. The consumption of SF₆ ceased in 2000.

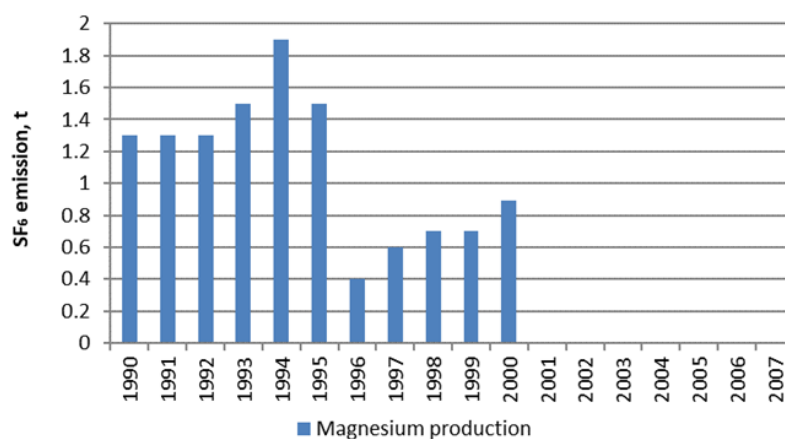

Figure 4.4.4 Emission of greenhouse gasses from the production of magnesium.

Time series consistency and completeness

The time series for magnesium production is considered to be both consistent and complete.

4.4.5 Secondary lead production

One Danish company producing secondary lead has been identified; Hals Metal. The following SNAP code is covered:

- 03 03 07 Secondary lead production

Methodology

Only one Danish company; Hals Metal, has been identified as producing secondary lead from scrap metal. Hals Metal closed down during 2021, and 2020 will be the last reported year with a full production. In addition to Hals metal, old lead tiles from castles, churches etc. are melted and recast on site during preservation of the many historical buildings in Denmark.

Activity data

Activity data from Hals Metal are provided by the company (Hals Metal, 2021). A clause affected in 2002 meant that Hals Metal could no longer burn cables containing lead. The processing of cables was therefore stopped and the company's activity changed to smelting. This transition resulted in a low activity in 2003.

The activity of recasting lead tiles is not easily found because it is spread out on many craftsmen and poorly regulated. However, an estimate by Lassen et al. (2004) states that 200-300 tonnes lead tiles were recast in 2000. Since the building stock worthy of preservation is constant, it is assumed that the activity of recasting of lead tiles is constant.

Activity data for secondary lead production are shown in Table 4.4.3 and Annex 3C-22.

Table 4.4.3 Activity data for secondary lead production, tonnes.

	1990	1995	2000	2005	2010	2015	2017	2018	2019	2020
Hals metal	540	750	540	691	635	745	605	348	322	194
Lead tiles	250	250	250	250	250	250	250	250	250	250
Total	790	1000	790	941	885	995	855	598	572	444

Emission factors

The applied CO₂ emission factor for secondary lead production is the default Tier 1 factor of IPCC (2006)⁴; 0.2 tonnes per tonne product.

Emission trends

The greenhouse gas emissions from the production of secondary lead are presented in Figure 4.4.5 below and Annex 3C-23.

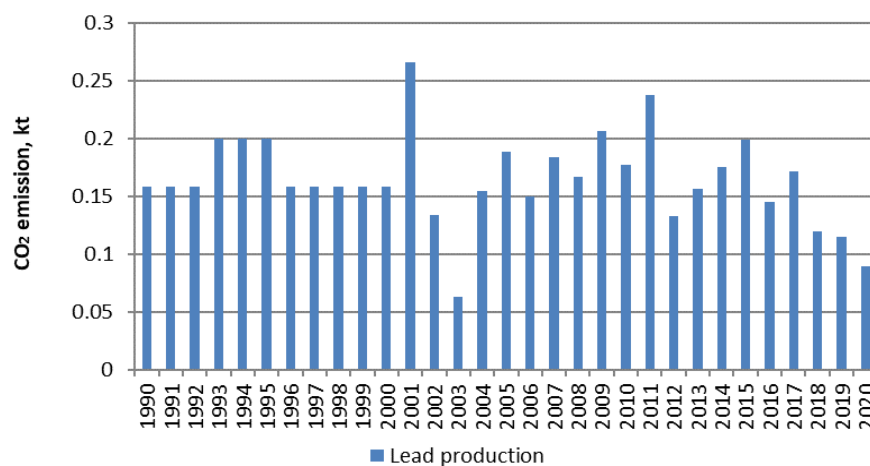

Figure 4.4.5 Emission of greenhouse gasses from secondary lead production.

Time series consistency and completeness

The time series for secondary lead production is considered to be both consistent and complete.

4.5 Non-Energy Products from Fuels and Solvent Use

4.5.1 Source category description

Non-Energy Products from Fuels and Solvent Use (CRF 2D) covers the following categories relevant for the Danish air emission inventory:

- 2D1 Lubricant use (SNAP 060604); see section 4.5.3
- 2D2 Paraffin wax use (SNAP 060606); see section 4.5.4
- 2D3 Solvent use (SNAP 0601, 0602, 0603, 0604); see section 4.5.5
- 2D3 Road paving with asphalt (SNAP 040611); see section 4.5.6
- 2D3 Asphalt roofing (SNAP 040610); see section 4.5.7
- 2D3 Urea-based catalysts (SNAP 060607); see section 4.5.8

4.5.2 Emissions

The time series for emission of greenhouse gasses from *Non-Energy Products from Fuels and Solvent Use* (2D) is presented in the CRF tables and in Figure 4.5.1 below.

⁴ Volume 3: Industrial Processes and Product Use, Chapter 4.6.2.2: Choice of emission factors, Table 4.21, page 4.73.

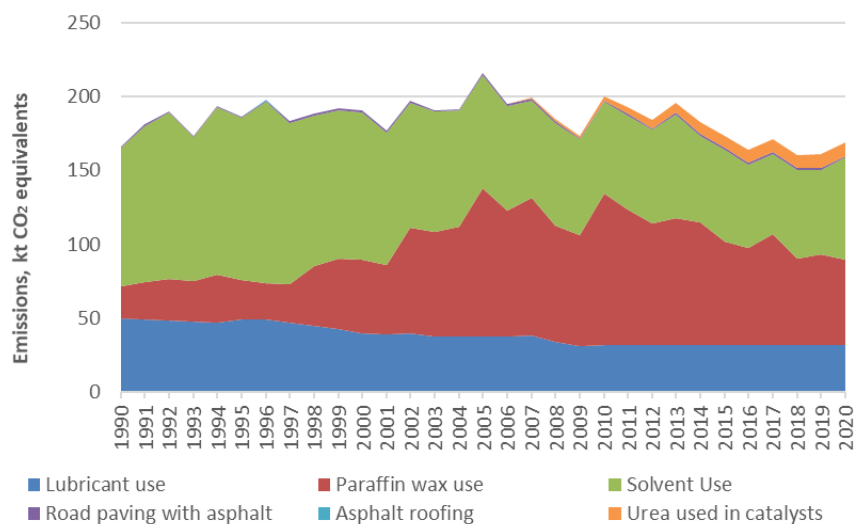

Figure 4.5.1 Emission of greenhouse gases from the individual source categories compiling 2D Non-Energy Products from Fuels and Solvent Use, kt CO₂ eqv.

The largest source of greenhouse gas emissions from *Non-Energy Products from Fuels and Solvent Use* is for 1990-2004 the use of solvents. As the use of solvents decrease (35 % decrease from 2000-2007) and the use of candles (i.e. paraffin wax use) increases (111 % increase from 2001-2005), the use of candles becomes the largest source of greenhouse gas emissions for 2005-2017. Since the peak in emissions from the use of candles in 2010, emissions have decreased with 44 % (2010-2020). Emissions from solvent use have found a more stable level since 2007. Solvent use and paraffin wax use contribute about equally to greenhouse gas emissions from *Non-Energy Products from Fuels and Solvent Use* in 2018-2019. With the introduction of Covid-19, the use of solvents (disinfectants) increased, making solvent use the dominant source in 2020.

4.5.3 Lubricant use

The category Lubricant use (CRF 2D1) covers the following process/SNAP code:

- 06 06 04 Oxidation of lubricants during use

Lubricants consumed in machinery (i.e. that is combusted during use) is included in this section. Collection of waste lubricants with subsequent combustion is reported in the energy sector.

Methodology

The emission of CO₂ from oxidation of lubricants during use is calculated according to the equation (IPCC, 2006):

$$E_{CO_2} = LC \cdot CC_{\text{lubricant}} \cdot ODU_{\text{lubricant}} \cdot 44/12 \quad (\text{Eq. 4.5.1})$$

Where E_{CO_2} is the CO₂ emission, LC is the consumption of lubricants, $CC_{\text{lubricant}}$ is the carbon content factor, $ODU_{\text{lubricant}}$ is the Oxidised During Use factor and 44/12 is the mass ratio of CO₂/C.

Equation 4.5.1 represents a Tier 1 approach where LC is the total amount of lubricant consumed in Denmark with no differentiation between greases and oils.

Activity data

The time series for consumption of lubricant oil in TJ is obtained from the Danish Energy Agency (2021) along with the calorific value of 41.9 GJ per tonne. The consumption has been reported as constant by the DEA since 2010. The consumption is presented in Table 4.5.1 and the complete time series in Annex 3C-24.

Table 4.5.1 Consumption of lubricant oil, kt.

	1990	1995	2000	2005	2010	2015	2017	2018	2019	2020
Lubricants	80.5	79.1	64.3	60.9	51.3	51.3	51.3	51.3	51.3	51.3

Emission factors

Table 4.5.2 Factors for calculation of the lubricant use emission factor.

Factor	Description	Source	Value Unit
CC _{lubricant}	The default carbon content factor	IPCC (2006), page 5.9	20.1 kg C/GJ
ODU _{lubricant}	The oxidised during use factor for grease	IPCC (2006), Table 5.2 page 5.9	0.2 -
CO ₂ /C	Mass ratio, 44/12	IPCC 2006, page 5.5	3.7 kg CO ₂ /kg C

The emission factor is calculated as the product: CC_{lubricant} · ODU_{lubricant} · 44/12 in Eq 4.5.1, and yields an emission factor of 14.7 kg CO₂ per TJ or 0.617 tonnes CO₂ per tonne lubricant used. This is constant for the entire time series.

Emission trends

The time series for CO₂ emission from oxidation of lubricants during use is presented in Table 4.5.3 and Annex 3C-25.

Table 4.5.3 Emissions from oxidation of lubricants during use, kt.

	1990	1995	2000	2005	2010	2015	2017	2018	2019	2020
Lubricants	49.7	48.8	39.7	37.6	31.7	31.7	31.7	31.7	31.7	31.7

Time series consistency and completeness

The applied methodology has been the same for all years in the time series, with activity data based on information from the Danish Energy Agency and using the same emission factor. The emission time series is therefore consistent. Since activity data are available from the energy statistics (Danish Energy Agency, 2021), the time series is also complete.

4.5.4 Paraffin wax use

The category Paraffin wax use (CRF 2D2) covers the following activity:

- 06 06 06 Combustion of paraffin wax candles

Paraffin waxes are used in applications such as candles, corrugated boxes, paper coating, board sizing, adhesives, food production, packaging, wax polishes, surfactants (used in detergents or in wastewater treatment), and many others. Emissions from the use of paraffin waxes occur primarily when they are combusted during use, e.g. candles, or when incinerated or used in waste water treatment. The latter cases should be reported in the energy or waste sectors, respectively (IPCC, 2006).

Methodology

In the Danish inventory, greenhouse gas emissions (CO₂, N₂O and CH₄) are only included from the main emission source: Combustion of paraffin wax candles. The methodology corresponds to a Tier 2 (IPCC, 2006), and assumes an oxidation factor of 100 %.

Activity data

Activity data are derived from import, export and production data for candles from Statistics Denmark (2021). The activity data are presented in Table 4.5.4 and in Annex 3C-26.

Table 4.5.4 Use of paraffin wax candles, kt.

	1990	1995	2000	2005	2010	2015	2017	2018	2019	2020
Paraffin wax use	7.4	9.1	16.9	34.4	35.2	24.0	25.7	20.0	21.0	19.8

Emission factors

The emission factors presented in Table 4.5.5 are constant for the entire time series and are compiled from the scientific literature. The IPCC (2006) CO₂ emission factor is valid for shale oil and is therefore not used.

Table 4.5.5 Emission factors for use of paraffin wax candles.

Pollutant	Unit	Value	Source
CO ₂	kt/kt	2.91	Shires et al. (2004)
N ₂ O	t/kt	0.024	Campbell et al. (2021)
CH ₄	t/kt	0.121	Campbell et al. (2021)

Emission trends

The time series for greenhouse gas emissions from paraffin wax use is shown in Table 4.5.6 and Annex 3C-27.

Table 4.5.6 Emissions from the use of paraffin wax candles.

	Unit	1990	1995	2000	2005	2010	2015	2017	2018	2019	2020
CO ₂	kt	21.7	26.5	49.3	100.2	102.3	70.0	74.9	58.3	61.0	57.6
CH ₄	t	0.9	1.1	2.0	4.2	4.3	2.9	3.1	2.4	2.5	2.4
N ₂ O	t	0.2	0.2	0.4	0.8	0.8	0.6	0.6	0.5	0.5	0.5
CO ₂ eqv	kt	21.7	26.6	49.4	100.6	102.7	70.2	75.1	58.5	61.2	57.8

Since the emission factors are constant throughout the time series, any increase or decrease in emissions are caused by an equal development in activity. Emissions increased with 363 % from 1990 to 2005, after which they started decreasing (-43 % from 2005-2020). The overall development from 1990 to 2020 in an increase of 166 %.

The decrease in the later years is believed to be caused by an increased awareness on indoor climate/pollution and an increased sale of LED candles.

Time series consistency and completeness

The time series is both consistent and complete.

4.5.5 Solvent use

The category Solvent use (CRF 2D3 Other) is aggregated according to the following categories, which correspond to the grouping in IPCC (2006):

- 06 01 00 Paint application
- 06 02 02 Degreasing, dry cleaning and electronics
- 06 03 00 Chemical products manufacturing or processing
- 06 04 00 Other use of solvents and related activities
- 06 04 03 Printing industry
- 06 04 08 Domestic solvent use (other than paint application)

Only NMVOC, which is subsequently oxidised to CO₂ in the atmosphere, is relevant for these categories. To be consistent with the reporting during the first commitment period of the Kyoto Protocol, Denmark has continued to report these indirect CO₂ emissions under sector 2D rather than reporting them separately under indirect CO₂.

Methodology

NMVOC emissions from solvent use are estimated using emission modelling of solvents by estimating the amount of (pure) solvents consumed, thus representing a chemicals approach, where each pollutant is estimated separately. All relevant solvents must be estimated, or at least those together representing more than 90 % of the total pollutant emission. These emissions are summed up to one national total CO₂ (NMVOC) emissions from solvent use.

The method is mainly based on the detailed approach and methodology described in EMEP/EEA (2019) and emissions are calculated for industrial sectors, households and for individual pollutants.

Activity data

Description of compilation of activity data can be found in Nielsen et al. (2021) Chapter 4.5.2. Activity data for solvent use is presented in Table 4.5.7 and Annex 3C-28.

Table 4.5.7 Solvent consumption activity data, kt.

	1990	1995	2000	2005	2010	2015	2017	2018	2019	2020
Paint application	83.5	91.0	104.2	74.6	45.1	43.1	38.4	37.5	43.5	48.5
Degreasing, dry cleaning and electronics	1.4	1.5	0.6	0.4	0.2	0.2	0.2	0.3	0.2	0.2
Chemical products manufacturing or processing	406.9	575.0	584.9	750.6	629.1	513.1	520.9	511.4	524.2	640.8
Other use of solvents and related activities	176.4	212.0	196.9	181.9	143.0	145.5	131.7	129.2	139.6	173.0
Printing industry	0.2	0.2	0.2	0.2	0.2	0.2	0.2	0.2	0.2	0.3
Domestic solvent use (other than paint application)	29.1	43.9	41.0	35.5	25.6	38.8	28.6	40.9	21.0	24.5

Emission factors

Emission factors are calculated for a complete conversion to CO₂ of each NMVOC molecule in units g CO₂ per g NMVOC from:

$$n \cdot 12 \frac{g}{mol} / (\text{molecular weight NMVOC}) \cdot 3.667 \frac{g CO_2}{g C}$$

where n is the number of carbon atoms in the NMVOC molecule. Further description of the methodology for derivation of emission factors in categories can be found in Nielsen et al. (2021) Chapter 4.5.2. The implied emission factors are presented in Table 4.5.8 and Annex 3C-29.

Table 4.5.8 CO₂ emission factors for solvent use.

	Unit	1990	1995	2000	2005	2010	2015	2017	2018	2019	2020
Paint application	t/kt	154.4	160.3	151.8	138.6	148.9	145.3	142.1	142.5	143.9	140.6
Degreasing, dry cleaning and electronics	t/kt	0.03	0.03	0.03	0.03	0.03	0.03	0.03	0.03	0.03	0.03
Chemical prod. manufacturing/processing	t/kt	47.8	40.5	29.7	20.8	19.3	23.7	22.1	24.4	25.4	25.2
Other use of solvents and related activities	t/kt	294.9	271.3	273.6	215.6	252.8	219.8	221.4	224.9	232.1	227.3
Printing industry	t/kt	81.1	86.4	80.1	70.4	77.6	76.0	75.5	75.7	76.8	79.2
Domestic solvent use (not paint application)	t/kt	321.1	331.3	328.0	315.8	267.8	308.3	293.7	318.8	270.3	279.0

Emission trends

Table 4.5.9, Figure 4.5.2 and Annex 3C-30 show the emissions of CO₂ from solvent use. The general decrease from 1997 to present is an indication of increased implementation of NMVOC emission reducing measures in production facilities, and a general shift to water soluble and high solid products, in e.g. the graphics-, paint-, plastic- and auto paint and repair industries. Further information can be found in Nielsen et al. (2021) Chapter 4.5.2.

Table 4.5.9 CO₂ emissions from solvent use.

	Unit	1990	1995	2000	2005	2010	2015	2017	2018	2019	2020
Paint application	kt	12.9	14.6	15.8	10.3	6.7	6.3	5.5	5.3	6.3	6.8
Degreasing, dry cleaning and electronics	kg	37.4	40.6	15.8	9.7	5.5	4.1	6.6	7.1	6.0	5.1
Chemical products manufacturing or processing	kt	19.4	23.3	17.4	15.6	12.1	12.2	11.5	12.5	13.3	16.1
Other use of solvents and related activities	kt	52.0	57.5	53.9	39.2	36.2	32.0	29.1	29.1	32.4	39.3
Printing industry	t	16.2	19.8	14.4	13.3	18.0	18.6	17.7	16.9	18.7	27.5
Domestic solvent use (not paint application)	kt	9.4	14.6	13.5	11.2	6.9	12.0	8.4	13.0	5.7	6.8
Total CO₂	kt	93.7	110.0	100.5	76.4	61.9	62.4	54.5	59.9	57.7	69.2

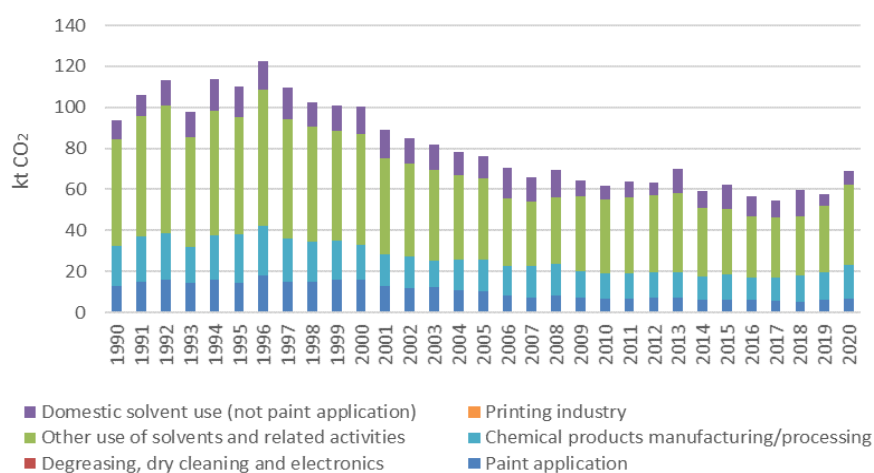

Time series consistency and completeness

The time series is considered to be both consistent and complete. For verification, please refer to Hjelgaard & Nielsen (2018).

4.5.6 Road paving with asphalt

The category Road paving with asphalt (CRF 2D3 Other) covers the following activity:

- 04 06 11 Road paving with asphalt

Methodology

Road paving with asphalt is an activity that can be found all over the country and especially in relation to establishing new traffic facilities. The raw materials for construction of transport facilities are prepared on one of the plants located near the locality of application to limit the transport distance. The asphalt concrete is mixed and brought to the locality of application on a truck.

Transport facilities are constructed by a number of different layers:

- a load bearing layer (e.g. course gravel)

- an adhesive layer (liquefied asphalt e.g. “cutback” asphalt or asphalt emulsion)
- a wearing coarse (e.g. hot mix asphalt concrete).

Different qualities of “cutback” asphalt (e.g. asphalt dissolved in organic solvents/petroleum distillates) and asphalt emulsion contains different kinds and amounts of solvent. Cutback asphalt contains 25-45%v/v solvent e.g. heavy residual oil, kerosene-type solvent, naphtha or gasoline solvent. Approximately 500.000 litre solvent evaporates annually from the use of “cutback” asphalt (Asfaltindustrien, 2003). This amount of solvent, which is added to the asphalt, is comprised in the category 2D3 Other: Solvent use, described above with an emission factor of approximately unity. This means that NMVOC emissions from “cutback” asphalt in Road paving only include emissions from the asphalt fraction, which is included in Table 4.5.10.

Indirect CO₂ emissions are calculated from NMVOC, CH₄ and CO emissions. To be consistent with the reporting during the first commitment period of the Kyoto Protocol, Denmark has continued to report indirect CO₂ emissions from road paving with asphalt under category 2D rather than separately under indirect CO₂.

Activity data

The used amounts of asphalt for road paving have been compiled from production, import and export statistics of asphalt products in Statistics Denmark (2021) and are presented in Table 4.5.10 and Annex 3C-31.

Table 4.5.10 Activity data for asphalt in road paving, kt.

	1990	1995	2000	2005	2010	2015	2017	2018	2019	2020
Road paving with asphalt	2535	3144	2933	3879	3005	3440	3662	4089	3508	3833

Emission factors

Emission factors are available in Table 4.5.11 below.

Table 4.5.11 Emission factors for road paving with asphalt incl. cutback.

Pollutant	Unit	Emission factor value	Source
CO ₂	kg/t	0.23	Calculated emission factor: Indirect CO ₂ from NMVOC, CH ₄ and CO
CH ₄	g/t	4.4	US EPA (2004)
NMVOC	g/t	16.0	EMEP/EEA (2019)
CO	g/t	120.2	US EPA (2004)

Emission trends

Greenhouse gas emissions from road paving with asphalt are presented in Table 4.5.12 and Annex 3C-32.

Table 4.5.12 Emissions from road paving with asphalt, t.

	1990	1995	2000	2005	2010	2015	2017	2018	2019	2020
CO ₂	583	723	675	892	691	791	842	940	807	882
CH ₄	11	14	13	17	13	15	16	18	15	17

Time series consistency and completeness

The time series is considered to be both consistent and complete.

4.5.7 Asphalt roofing

The source category Asphalt roofing (CRF 2D3 Other) covers the following activity:

- 04 06 10 Asphalt roofing

Methodology

The asphalt industry produces a number of products, e.g. roofing and siding shingles, for use in roofing. Key steps in the total production and roofing process include asphalt storage, asphalt blowing, felt saturation, coating and mineral surfacing.

Asphalt blowing is the process of polymerising and stabilising asphalt to improve its weathering characteristics, and it may take place in an asphalt processing or roofing plant, or in a refinery. Only asphalt blowing is covered in IPCC (2006) and in the Danish inventory, as it leads to the highest emissions of NMVOC and CO in the total production and roofing process.

Indirect CO₂ emissions from NMVOC and CO emissions from asphalt blowing in asphalt roofing are included. To be consistent with the reporting during the first commitment period of the Kyoto Protocol, Denmark has continued to report indirect CO₂ emissions from asphalt roofing under category 2D rather than separately under indirect CO₂.

Activity data

The use amounts of asphalt for roofing have been compiled from production, import and export statistics of asphalt products in Statistics Denmark (2021). Activity data are presented in Table 4.5.13 and Annex 3C-33.

Table 4.5.13 Activity data for asphalt roofing, kt.

	1990	1995	2000	2005	2010	2015	2017	2018	2019	2020
Asphalt roofing	56.1	57.0	88.5	69.6	43.9	47.0	53.2	59.5	59.8	60.1

Emission factors

Emission factors are available in Table 4.5.14 below.

Table 4.5.14 Emission factors for asphalt roofing (asphalt blowing).

Pollutant	Unit	Emission factor value	Source
CO ₂	kg/t	0.40	Calculated emission factor: Indirect CO ₂ from NMVOC and CO
NMVOC	g/t	130	EMEP/EEA (2019)
CO	g/t	9.5	EMEP/EEA (2019)

Emission trends

Greenhouse gas emission from asphalt roofing are presented in Table 4.5.15 and Annex 3C-34.

Table 4.5.15 Emissions from asphalt roofing, t.

	1990	1995	2000	2005	2010	2015	2017	2018	2019	2020
CO ₂	22.4	22.8	35.4	27.8	17.6	18.8	21.3	23.8	23.9	24.0

Time series consistency and completeness

The time series is considered to be both consistent and complete.

4.5.8 Urea-based catalysts

Methodology

The category Urea-based catalysts (CRF 2D3 Other) covers CO₂ emissions from urea-based additives used in catalytic converters in heavy duty vehicles to bring down NO_x emissions:

- 06 06 07 Urea-based catalysts

The consumption of urea by SCR catalysts for heavy duty vehicles is estimated with the DCE emission model for road transport by using fuel consumption totals and urea consumption rates for relevant engine technologies. The DCE model uses the COPERT 5 detailed methodology as explained in Chapter 3.3. SCR catalysts are used by Euro V and VI trucks and to a smaller extent by Euro IV trucks as an emission abatement technology in order to bring down NO_x emissions.

Activity data

According to COPERT 5, the consumption of urea is 5-7 % by volume of fuel for Euro IV/V heavy duty vehicles (6 % is used) and 3-4 % for Euro VI heavy duty vehicles (3.5 % is used). Activity data for the use of urea is presented in Table 4.5.16 and Annex 3C-35.

Table 4.5.16 Activity data for use of urea in catalysts, kt.

	2001	2005	2010	2015	2017	2018	2019	2020
Urea	0.002	0.040	10.6	34.0	37.4	38.1	38.4	38.1

Emission factors

For each vehicle layer, the emissions of CO₂ are subsequently estimated as the product of urea consumption and a CO₂ emission factor of 0.26 kg CO₂ per l urea (EMEP/EEA, 2019).

Emission trends

CO₂ emissions from the use of urea in catalysts are presented in Table 4.5.17 and Annex 3C-36.

Table 4.5.17 CO₂ emissions from the use of urea in catalysts, kt.

	2001	2005	2010	2015	2017	2018	2019	2020
CO ₂	0.001	0.010	2.5	8.1	8.9	9.1	9.2	9.1

Time series consistency and completeness

The time series is considered to be both consistent and complete.

4.6 Electronics Industry

4.6.1 Source category description

The sector *Electronic Industry* (CRF 2E) covers the use of HFCs and PFCs in the production of fibre optics. There is no production of semiconductors, TFT flat panels or photovoltaics with use of F-gases in Denmark. No use of HFCs or PFCs as heat transfer fluids occur in Denmark.

As a result the only relevant category is:

- 2E5 Other: HFC-23, PFC-14 (CF₄) and PFC-318 (c-CF₄F₈) from fibre optics

The description of consumption and emission of F-gases given below is based on an inventory by Poulsen (2022). For further details refer to these reports.

4.6.2 Emissions

The use of F-gases in the production of fibre optics did not start until 2001 and hence the time series covers the years 2001-2020. The emission time series for *Electronics Industry (2E)* is available in the CRF tables but is also presented in Figure 4.6.1.

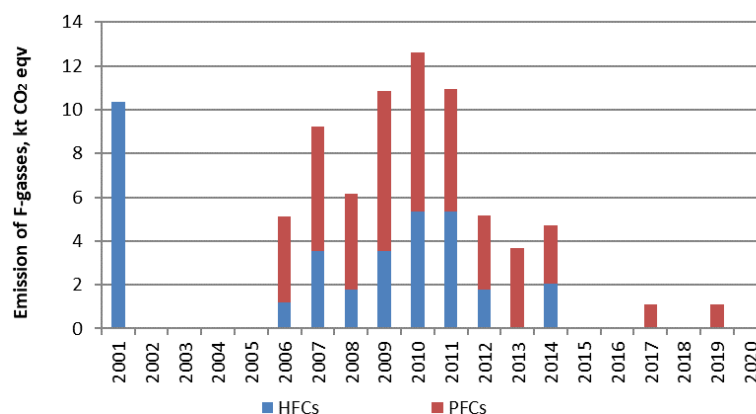

Figure 4.6.1 Emissions of HFCs and PFCs from *Electronics Industry*.

4.6.3 Other electronics industry

As mentioned above, optic fibre production is the only source category relevant for the Danish inventory on electronic industries.

Methodology

Both HFCs (HFC-23) and PFCs (PFC-14 and PFC-318) are used for technical purposes in Danish optics fibre production for protection and as cleaning gases in the production process. Information on consumption of HFCs and PFCs in production of fibre optics is derived from annual importers' sales report with specific information on the amount used for production of fibre optics. This is believed to represent 100% of the Danish consumption of F-gases for that purpose. The emission factor is 1, i.e. 100 % release in the production year (i.e. year of consumption). The methodology corresponds to the IPCC Tier 2 method.

Activity data

There has been no use of F-gasses in 2002-2005, 2015-2016, 2018 or 2020. The consumption data are provided in Figure 4.6.2 below and Annex 3C-37.

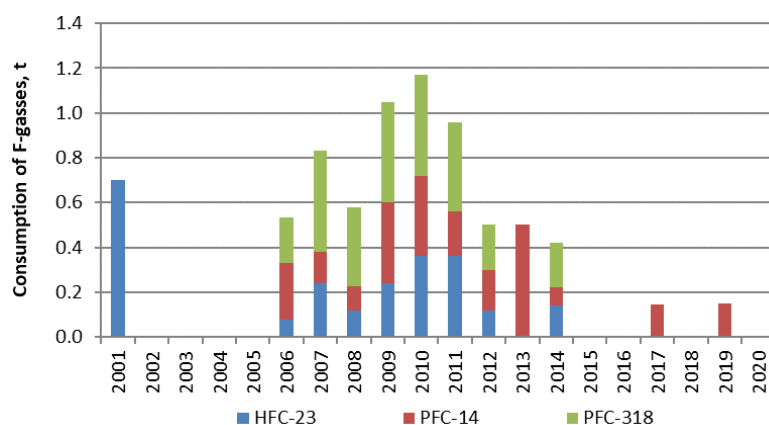

Figure 4.6.2 Consumption of F-gases in production of fibre optics, t.

Emission factors

Since HFC-23 and the PFCs are used as protection and cleaning gases as well as for etching in optics fibre production, the emission factor is defined as 100 % release during production.

Emission trends

Emission trends are presented in Figure 4.6.3 below and Annex 3C-38.

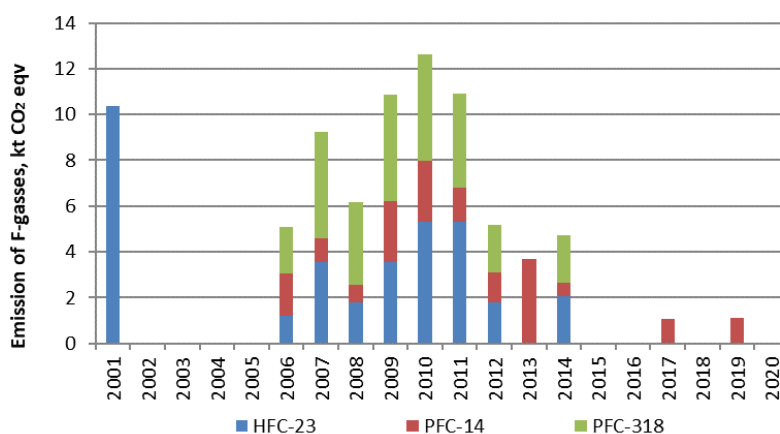

Figure 4.6.3 Emissions from Electronic industry, kt CO₂ eqv.

Time series consistency and completeness

The estimates are based on information directly from the importer supplying this sector in Denmark. As Denmark is a small country with a limited consumption of F-gases, there are only few importers. Data collection for the F-gas report (Poulsen, 2022) is done in close cooperation with the industry associations enabling inclusion of any new importers of F-gases or F-gas containing products. The time series is therefore considered both complete and consistent.

4.7 Product Uses as Substitutes for Ozone Depleting Substances (ODS)

4.7.1 Source category description

The sub-sector *Product uses as substitutes for ODS* (2F) includes the following source categories and the following F-gases of relevance for Danish emissions:

- 2F1: Refrigeration and air conditioning: HFC-32, -125, -134a, -143a, -152a, PFC-218 and PFC-14
- 2F2: Foam blowing agents: HFC-134a and HFC-152a

- 2F4: Aerosols: HFC-134a and HFC-227ea
- 2F5: Solvents: PFC-218

It must be noted that the inventories for the years 1990-1994 might not cover emissions of these gases in full. The choice of base-year for these gases under the Kyoto Protocol is 1995 for Denmark.

Two key categories were identified for the emission of HFCs in the sub-sector *Product uses as substitutes for ODS (2F)*; refrigeration and air conditioning for level in 2020 and for trend (both Approach 1 and Approach 2) and foam blowing agents for level in the base year (Approach 1) and for trend (both Approach 1 and Approach 2).

The description of consumption and emission of F-gases given below is based on an inventory by Poulsen (2022). For further details, refer to this report.

All descriptions in Chapter 4 of this report, refer to activities in mainland Denmark. Emissions presented in DNK CRF tables include emissions from Greenland and the Faroe Islands; including some F-gasses. Inter-annual variations in the DNK time series are naturally likely to occur, e.g. if F-gas consumption decreases significantly in mainland Denmark but not in Greenland.

4.7.2 Emissions

The emission time series for *Product uses as substitutes for ODS (2F)* are presented in Figure 4.7.1 and Figure 4.7.2 below.

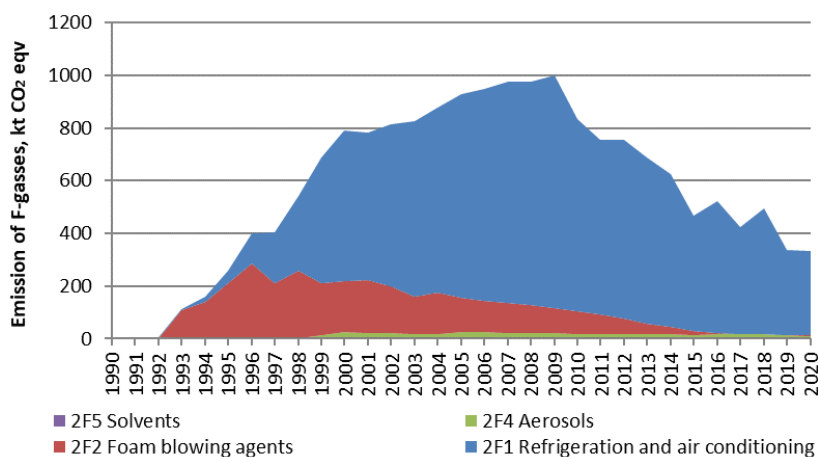

Figure 4.7.1 Emission of F-gases from the individual source categories within 2F *Product uses as substitutes for ODS*, kt CO₂ eqv.

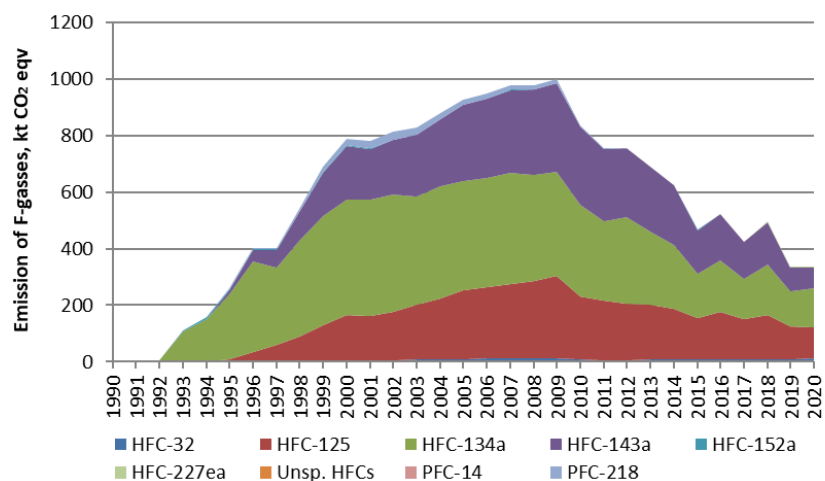

Figure 4.7.2 Emission of F-gases from the individual gases within 2F Product uses as substitutes for ODS, kt CO₂ eqv.

The emission of HFCs increased rapidly in the 1990s and, thereafter, increased more modestly due to a moderate increase in the use of HFCs as a refrigerant and a decrease in foam blowing. The F-gases have been regulated in two ways since 1 March 2001. For some types of use there is a ban on use of the gases in new installations and for other types of use, taxation is in place. These regulations seem to have influenced emissions so that since 2009, an overall decreasing trend can be observed.

General trends

The phase out of F-gases has in particular been effective within the foam blowing sector and refrigeration and air conditioning installations. Regarding foam blowing, there was a stepwise phase-out of HFC-134a used for foam blowing in closed cell and open cell foam production, during the period 2001-2004. Especially the phase-out of HFCs in open cell foam is significant for the emission in this period.

Since the introduction of taxes on HFCs in 2001, the consumption and emissions from foams has seen a steady decrease and is now almost entirely gone. Emissions still occur from stock in closed cell foams, but no HFCs have been filled into new products (nor imported in new products) since 2016.

The emission of HFCs for refrigeration continued to increase until 2009, especially HFC-404a and HFC-134a increased. This increase is explained with other initiatives in Danish legislation, where new refrigeration systems containing HCFC-22 (ODS) was banned from 2001. It caused a boom in refrigeration systems using HFCs during 2002-2004, because the HFC technology was cheap and well proven. The consumption of HFCs for refrigeration changed significantly after 1 January 2007, where new larger HFC installations with charges exceeding 10 kg were banned. The emission of HFC-134a peaked in 2007, but the peak for HFC-125 and HFC-143a is not seen until 2009. Alternative refrigeration technologies based on CO₂, propane/butane and ammonia are now introduced and available for customers.

The import of PFC-218 (C₃F₈) has been very low since 2010, and as expected, this refrigerant has been phased out of the market. Emissions have been decreasing since 2003, and no emissions of PFC-218 are reported after 2014. Emissions from the use of PFC-218 (C₃F₈) as a solvent only occurred from 2000 to 2003.

A quantitative overview is given below (Figure 4.7.3 – Figure 4.7.6) for each of the four source categories, showing their emissions in tonnes of CO₂ equivalents through the times series.

4.7.3 General methodology

The data for emissions of HFCs and PFCs have been obtained in continuation of the work on previous inventories. The determination includes the quantification and determination of any import and export of HFCs and PFCs contained in products and substances in stock form. This is in accordance with the IPCC guidelines (IPCC, 2006).

For the Danish inventories of F-gases, a Tier 2 bottom-up approach is basically used. In Annex 3 to the F-gas inventory report (Poulsen 2022), there is a specification of the approach applied for each sub-source category.

The following sources of information have been used:

- Importers, agency enterprises, wholesalers and suppliers
- Consuming enterprises, and trade and industry associations
- Danish Environmental Protection Agency
- Recycling enterprises and chemical waste recycling plants
- Statistics Denmark
- Danish Refrigeration Installers' Environmental Scheme (KMO)
- Previous evaluations of HFCs, PFCs and SF₆

Suppliers and/or producers provide consumption data of F-gases. Emission factors are primarily defaults from the IPCC guidelines, which are assessed to be applicable in a national context. In the case of commercial refrigerants and Mobile Air Conditioning (MAC), information from Danish suppliers has been used. The actual amount of F-gas used for refilling is used as an estimate on the actual emission.

Import/export data for sub-source categories where import/export is relevant (e.g. MAC and fridges/freezers for households) are quantified on estimates from import/export statistics of products + default values of the amount of gas in the product. The estimates are transparent and described in Appendix 3 of Poulsen (2022).

The Tier 2 bottom-up analysis used for determination of emissions from F-gases covers the following activities:

- Screening of the market for products in which F-gases are used
- Determination of averages for the content of F-gases per product unit
- Determination of emissions during the lifetime of products and disposal
- Identification of technological development trends that have significance for the emission of F-gases
- Calculation of import and export is based on defined key figures, and information from Statistics Denmark on foreign trade and industry information

The determination of emissions of F-gases is based on a calculation of the actual emission. The actual emission is the emission in the evaluation year, accounting for the time lapse between consumption and emission. The actual emission includes Danish emissions from production, from products during their lifetimes and from disposal.

Consumption and emissions of F-gases are determined for individual substances, even though the consumption of certain HFCs has been very limited. This has been carried out to ensure transparency of evaluation in the determination of GWP values.

The substances have been accounted for in the annual survey according to their trade names, which are mixtures of HFCs used in the CRF, etc. In the transfer to the "pure" substances used in the CRF reporting tables, the ratios provided in Table 4.7.1 have been used.

Table 4.7.1 Content (w/w%)¹ of "pure" HFC in HFC-mixtures, used as trade names.

HFC mixtures	HFC-32	HFC-125	HFC-134a	HFC-143a	HFC-152a	HFC-227ea
	%	%	%	%	%	%
HFC-365						8
HFC-401a					13	
HFC-402a		60				
HFC-404a		44	4	52		
HFC-407c	23	25	52			
HFC-410a	50	50				
HFC-507a		50		50		

¹The mixtures also contain substances that do not have GWP values and therefore, the substances do not sum up to 100 %.

The national inventories for F-gases are provided and documented in an annual report (Poulsen 2022). Furthermore, detailed data and calculations are available and archived in an electronic version. The report contains summaries of methods used and information on sources as well as further details on methodologies.

4.7.4 Refrigeration and air conditioning

2F1 Refrigeration and air conditioning consists of the following subcategories:

- 2F1a Commercial refrigeration
- 2F1b Domestic refrigeration
- 2F1c Industrial refrigeration (included under commercial)
- 2F1d Transport refrigeration
- 2F1e Mobile air conditioning
- 2F1f Stationary air conditioning

The use of HFCs in industrial refrigeration was previously surveyed and the conclusion was that large-scale industrial refrigeration e.g. slaughterhouses, fish factories and medico companies use ammonia based refrigeration units. This is particularly caused by the tax on HFCs in Denmark that makes HFC based refrigeration units with large charges too expensive and furthermore the ban from 2007. Smaller HFC based units will occur in industry, but is then similar to commercial refrigeration units. Since it is not possible to separate small-scale industrial and commercial refrigeration units, all consumption and emissions are reported under commercial refrigeration.

Methodology

For refrigeration and air conditioning, Denmark uses mainly the Tier 2 top-down approach (Tier 2b). However, for Domestic Refrigeration the methodology is a combination of Tier 2a and 2b. For more information on the applied methodology please refer to Poulsen (2022).

According to Danish law, refrigerators and air conditioning equipment must be emptied before decommissioning by recovery, reuse or destruction of the remaining gases. It is reasonable to assume that this law is upheld in Denmark since waste collection is mandatory and there are no extra charges for e.g. getting rid of a used refrigerator. In addition, to recycling plants where companies and individuals can deliver their waste, there is also a collection scheme where e.g. used refrigerators are collected at the sidewalks and disposed of. Due to this there is no reason why people would chose to illegally dispose of an appliance when the legal disposal is both free and easy. The notation key "Not occurring" (NO) is therefore used in the CRF for the amounts of HFCs remaining in products at decommissioning.

For the early period of the time series (1994-2000), transport refrigeration and mobile air conditioning were included in one common activity reported under 2.F.1.e Mobile air conditioning. When data became available to allow for the split between these two activities this was implemented. For the transport refrigeration category is used a decommissioning rate of 10 % four years after the consumption. This results in small amounts of HFC-125 and -143a (from HFC-404a) for decommissioning in 1997-2000 in 2.F.1.e. After this period, HFC-404a is no longer reported in 2.F.1.e, but only as used in transport refrigeration (2.F.1.d).

Activity data

The data collection is described in the Chapter 4.7.3 General methodology.

The activity data expressed as total amount of HFCs and PFCs filled into new products, present in operating systems and remaining in products at decommissioning are included in the CRF tables and are not repeated here.

PFC-14 was used in Denmark for a brief period as refrigerant for specialized low-temperature (-60°C) freezers for laboratory purposes. Use of PFC-14 for these extreme low temperature laboratory freezers has been registered for 2015-2018, and is placed under 2.F.1.b Domestic refrigeration. By 2019 CF₄ was already substituted with other refrigerants. In 2017 and 2018 the consumption figures were identical.

Heat pumps are part of category 2.F.1.f Stationary air conditioning. There is however no production of heat pumps in Denmark and the stock of HFC-32, HFC-125 and HFC-134a in heat pumps therefore increases without any emissions from manufacture. Import of F-gasses in heat pumps is included in "filled into new products" in the CRF table, this causes the "product manufacturing factor" to be below the 0.2 displayed in Table 4.7.2 below.

Emission factors

The applied emission factors are presented in Table 4.7.2.

Table 4.7.2 Applied emission factors for refrigeration and air condition systems.

	Assembly, %	Stock, % per annum	Lifetime, years	Recovery, %
2.F.1.a Commercial and industrial refrigerators ¹	0.5-1.5	10	15	88.5
2.F.1.b Household fridges and freezers	2	1	15	100
2.F.1.d Transport refrigeration	0.5	17	7	88.5
2.F.1.e Mobile air conditioning systems ²	0.2-4.5	10-30	3-15	88.5-100
2.F.1.f Stationary air conditioning ³	0.2-1.5	3-10	15	88.5-100
- Heat pumps ⁴	0.2	3	10	80

¹ For commercial refrigerators EFs change from 2010 onward, from 1.5 % to 0.5 % for assembly. This is not the case for retail and industrial refrigeration systems.

² For pure HFC-134a, EFs are 4.5 % from assembly, 30 % leakage, 15 years and 88.5 % recovery and for HFC-404a, EFs are 4.5 %, 30 %, 3 years and 100 % recovery.

³ For all HFCs EFs change from 2010 onward, from 1.5 % to 0.2 % for assembly, and from 10 % to 3 % for stock. For PFC-218 recovery is 100 %.

⁴ EFs for heat pumps are mentioned separately from the remaining 2.F.1.f category.

The reduction in emission factor from 10% leakage rate to 3% leakage rate from 2010 (2.F.1.f) is implemented based on an expert judgement of when the technologies improved and next generation units were introduced to the market (Poulsen 2022). This reduction in leakage rate has been investigated, and also discussed in the Nordic working group on F-gases. Based on the discussions among experts, it is clear that the actual level is in the range of 1-4 % and that this has been the level for a number of years. Considering the negligible impact on the emissions, it has been decided to use this approach with a sharp drop in 2010, until more detailed knowledge becomes available that can form the basis for recalculations.

Detailed information on the amount of HFCs used for refilling of mobile A/C has been available and applied for the years 2009 - 2011, and therefore, a new approach has been implemented in the calculation of emissions from these years onward. Starting from 2009, the refilled and consumed amount of HFC-134a is calculated based on a Tier 2 top-down approach where the importers of HFC-134a for mobile A/C systems are isolated. The consumption of HFC-134a for mobile A/C systems is used solely for refilling. Car manufacturers outside Denmark carry out initial filling. (Poulsen, 2022):

Consumption of HFC for MAC = refilled stock = emission

From 2012 onward, the applied methodology for mobile air conditioning results in a product life factor around 30 % (21-36 %). For years prior to the shift in methodology mentioned above, the product life factor was exactly 30 % as mentioned in Table 4.7.2.

Emission resulting from disposal of items and equipment in the applications differs from 0-20%. For most categories the emission is calculated as 0% because Danish legislation ensures that management and treatment of refrigerants prevent uncontrolled emissions. For heat pumps the emission at decommissioning is estimated as 20% due to lack of control measures with decommissioning of air-air heat pumps from private household. (Poulsen, 2022)

For domestic refrigeration, the emission from stock presented in the CRF tables is a sum of annual emissions in the product lifetime. The product life factor is therefore not exactly equal to 1% (0.5% for laboratory freezers) as otherwise stated in Table 4.7.2.

For heat pumps, emission from stock is (like for domestic refrigeration) a sum of annual emission over lifetime. This results in varying odd numbers for the product life factor. Emission at decommissioning is 20% for heat pumps and 11.5% for stationary air conditioning, the disposal loss factor presented in the CRF tables therefore end up around 13-14%.

Emission trends

Figure 4.7.3 present the emissions of F-gases from consumption of HFCs and PFCs in the individual sub-categories of refrigeration and air conditioning systems.

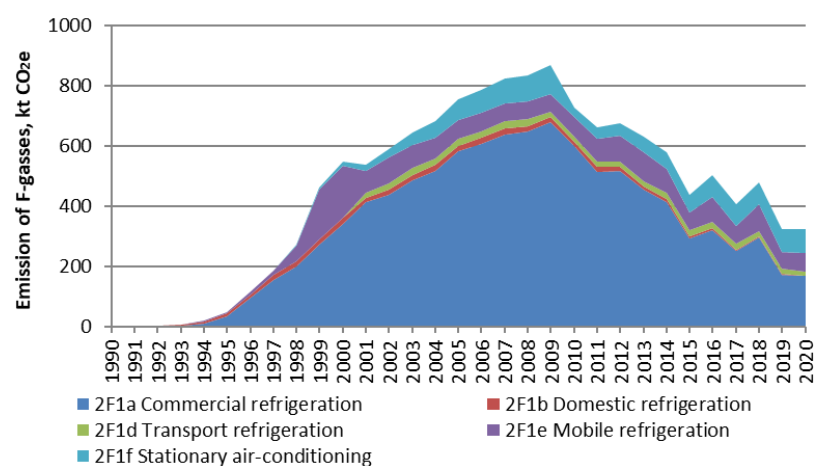

Figure 4.7.3 Emissions from refrigeration and air conditioning.

F-gas emissions from commercial refrigeration are dominating the overall emissions from this source. Hence, the increasing trend from the mid-1990s to 2009 and the subsequent decrease in emissions are explained in Chapter 4.7.2 Emissions.

The decrease in emissions from mobile air -conditioning in the recent years, is related to the lower consumption of HFC-134a. HFO-1234yf (GWP value of only 4) is increasingly being used as a substitute for HFC-134a in new mobile air conditioning systems. HFO-1234yf is not report under the UNFCCC and is therefore not included in this report.

EU F-gas Regulation 517/2014, Annex III entered into force on 1 January 2015 placing a ban on sale/installation of domestic refrigeration appliances containing F-gases with a GWP>150. However, for 2015-2020 amounts of HFC 125 (GWP 3500), HFC-134a (GWP 1430) and HFC 143a (GWP 4470) are reported as "filled into new manufactured products" in the domestic refrigeration subcategory. The single producer responsible for this consumption confirms the consumption of HFC 134a and HFC-404a for domestic appliances and biomedical coolers and freezers. The amounts are decreasing.

4.7.5 Foam blowing agents

2F2 Foam blowing agents consists of the following processes:

- Closed cells (hard PUR foam plastics and polyether foam)
- Open cells (soft PUR foam plastics)

In Denmark, five specific processes have occurred during the time series, i.e. foam in household fridges and freezers (closed cell), soft foam (open cell),

joint filler (open cell), foaming of polyether for shoe soles (closed cell) and system foam for panels, insulation etc. (closed cell).

Methodology

The methodology used varies between the different processes. For all processes the methodology corresponds to the Tier 2 level of IPCC (2006). For some processes a bottom-up methodology is applied while for others a top-down approach or a combination of top-down and bottom-up is used. For more information on the details of the applied methodology, please refer to Poulsen (2022).

Activity data

The data collection is described in the Chapter 4.7.3 General methodology.

There is no longer production of HFC-based hard PUR insulation foam in Denmark. This production has been banned in statutory order since 1. January 2006 (MIM, 2002).

Emission factors

The applied emission factors for foam blowing agents are presented in Table 4.7.3 (Poulsen, 2022 – Appendix 3).

Table 4.7.3 Applied emission factors for foam blowing agents (2F2).

	Consumption %	Stock %	Lifetime years
Foam in household fridges and freezers (closed cell)	10 ⁴	4.5 ⁴	15 ⁵
Soft foam (open cell) ¹	100 ⁴		
Joint filler (open cell) ¹	100 ⁴		
Foaming of polyether for shoe soles (closed cell)	15 ⁵	4.5 ⁵	3 ⁵
System foam (for panels, insulation, etc.)	0 ²	- ³	

¹ 100 % emission during the first year after production. ² HFC is used as a component in semi-manufactured goods and emissions first occur when the goods are put into use. ³ System foam is only produced for export. ⁴ IPCC (2006) default, ⁵ Danish default.

System foam is produced in a closed environment and is only produced for export. Therefore, the consumption of HFCs does not contribute to the Danish stock.

The emission factors for foam in fridges and freezers, soft foam and joint filler are default values from (IPCC, 2006⁵). The emission factors for foaming of polyether are country-specific (Poulsen, 2022).

The F-gases remaining in products at decommissioning (closed cell products) are destroyed by incineration and hence there are no F-gas emissions related to disposal of these products.

Emission trends

Figure 4.7.4 presents the emissions of F-gases from consumption of HFCs in foam blowing agents.

⁵ Volume 3: Industrial Processes and Product Use, Chapter 7.4.2.1: Foam blowing agents, Choice of method, Table 7.5, page 7.35 and Chapter 7.4.2.3: Foam blowing agents, Choice of activity data, page 7.38.

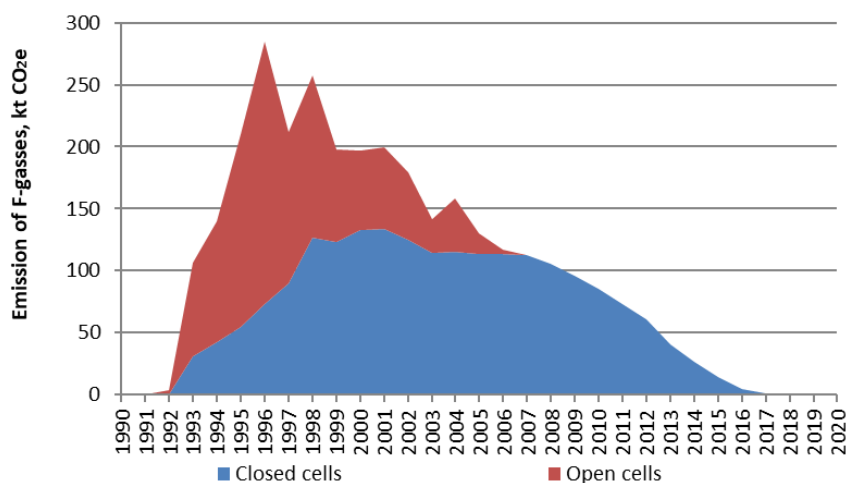

Figure 4.7.4 Emissions from foam blowing agents.

The sharp fluctuations in the time series are caused by fluctuations in the consumption of HFCs in production of open cell foam, with an emission factor of a 100 % in the given year. For the later part of the time series the trend reflects the limited use of HFCs and reflects the emission from the stock of previous use of HFCs.

4.7.6 Fire protection

No HFCs or PFCs are used in fire protection in Denmark. The use of halogen substituted hydrocarbons has been banned since 1977 (MIM, 1977), this ban is still in place (MIM, 2015).

Halon-1301 has been used in planes, in the military, in server rooms and on ships. New fire protection systems use other technologies, e.g. early fire detection, inert gases or gas mixtures (argon, nitrogen and CO₂) or water vapour. For mobile systems halon-1211 has been replaced with CO₂ or foam fire extinguishers.

4.7.7 Aerosols

2F4 Aerosols consist of HFCs used for:

- Propellant in aerosols
- Metered dose inhalers

Methodology

The general data collection process is described in the section 4.7.3 General methodology.

For HFC use as propellant in aerosol cans the IPCC (2006) Tier 2a default methodology is used. A default emission factor of 50 % of the initial charge per year is used for aerosols. For metered dose inhalers (MDI) a Tier 2 bottom-up approach is used and an emission factor of 100 % of the initial charge per year is applied.

Information on propellant consumption is derived from reports on consumption from the only major producers of HFC-containing aerosol sprays in Denmark. The import and export are estimated by the producer.

Information on consumption of F-gasses in MDIs is based on data from the national medical trade statistic and information on product content of HFCs from the producers.

As all F-gasses are assumed to be released during the product lifetime for all aerosols, there are no F-gasses remaining in products at decommissioning and therefore no emission from decommissioning and no recovery of F-gasses. The notation key used for these is therefore “NO” (not occurring).

Activity data

From 2019 and forth, the use of HFC-134a is phased out and substituted with HFO-1234ze⁶ (GWP value of 7) as propellants in aerosols for specific industrial purposes. 2019 will therefore be the last year of submitted HFC emissions from source category 2.F.4.b Other aerosols.

HFC-134a has been used in medical metered dose inhalers since 1998, but HFC-227ea is only introduced from 2015.

Emission factors

The applied emission factors are presented in Table 4.7.4 (Poulsen, 2022).

Table 4.7.4 Applied emission factors for aerosols/medical dose inhalers.

	Consumption/filling	Stock	Lifetime
Aerosols	0 %	50 % first year 50 % second year	2 years
Medical dose inhalers	0 %	100 % in year of application	1 year

Emission trends

Figure 4.7.5 presents the emissions of F-gases from consumption of HFCs in aerosols.

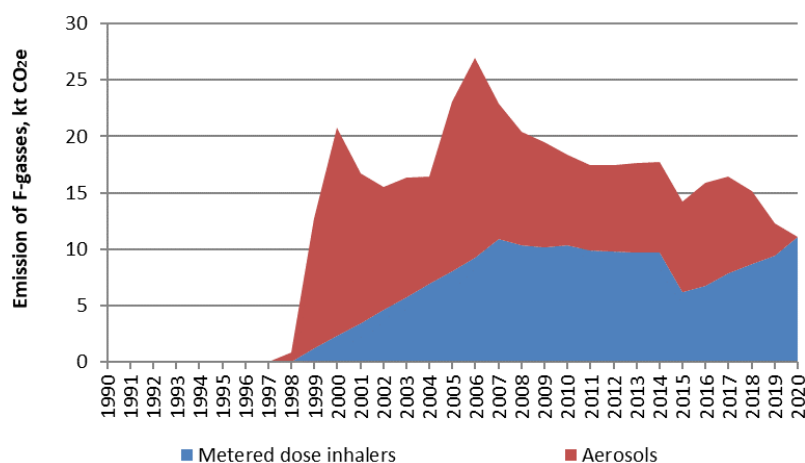

Figure 4.7.5 Emissions from aerosols.

Due to the methodology used, the fluctuations in the time series are a result of changes in import, production and export. Baring these fluctuations in mind the emission level has been rather constant at a level between 14 and 20 kt CO₂ equivalents in 2000-2018, but has dropped to 11-12 kt CO₂ equivalents from 2019 due to the phase out of HFC-134a in Aerosols.

⁶ HFOs are not reported under the UNFCCC and is therefore not included in this report.

4.7.8 Solvents

C₃F₈ was used as cleaner from 2000 to 2002 (emissions in 2000-2003) and the use then ceased following the ban in accordance with the Executive Order (MIM, 2002).

Methodology

The methodology used is the IPCC (2006) default and the fraction of chemical emitted from solvents in the year of initial use is assumed to be 50 % in line with good practice. The other 50 % is assumed to be emitted in the second year and hence there is no subtraction of any destruction of solvents.

Activity data

The general data collection process is described in the section 4.7.3 General methodology.

Information on consumption of PFCs in liquid cleaners is derived from two importers' sales reports. This is representing 100% of the Danish consumption.

Emission factors

In accordance with IPCC (2006)⁷, the emission factor is 50 % in year 1 and 50 % in year 2.

Emission trends

Figure 4.7.6 presents the emissions of F-gases from consumption of PFCs used as solvents.

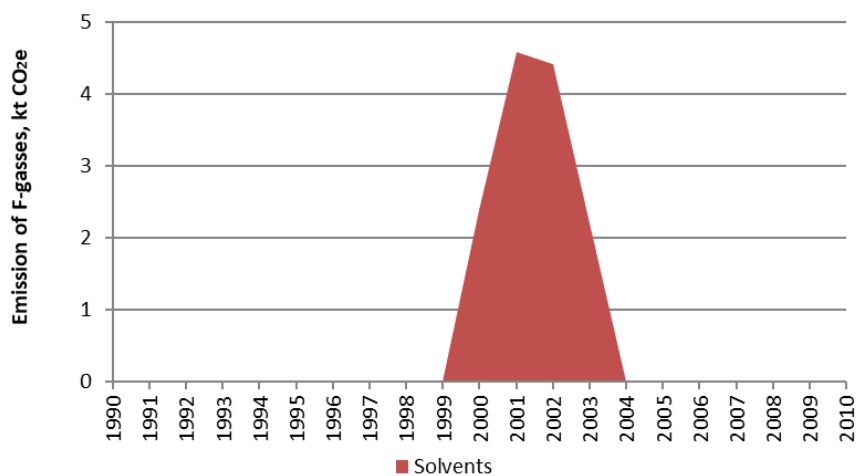

Figure 4.7.6 Emissions from PFCs used as solvents.

As mentioned the use of PFCs as solvent only occurred from 2000 to 2002 and hence emissions only occurred from 2000 to 2003.

4.8 Other Product Manufacture and Use

4.8.1 Source category description

The sector *Other Product Manufacture and Use* (CRF 2G) covers the following processes relevant for the Danish air emission inventory:

⁷ Volume 3: Industrial Processes and Product Use, Chapter 7.2.2.1: Solvents (non-aerosol), Choice of method, Equation 7.5, page 7.23 and Chapter 7.2.2.2: Solvents (non-aerosol), Choice of activity data, page 7.24.

- 2G1 Electrical equipment (SNAP 060507); see section 4.8.3
- 2G2 SF₆ from other product uses (SNAP 060508); see section 4.8.4
- 2G3a Medical applications (SNAP 060501); see section 4.8.5
- 2G3b N₂O used as propellant for pressure and aerosol products (SNAP 060506); see section 4.8.6
- 2G4 Other product uses (SNAP 060601, 060602, 060605); see section 4.8.7

4.8.2 Emissions

Total greenhouse gas emissions from the *Other Product Manufacture and Use* (2G) sector are available in the CRF Table 10. The emission time series for the source categories within 2G are presented in Figure 4.8.1 and individually in the subsections below (Sections 4.8.3 – 4.8.7). The following figure gives an overview of which source categories contribute the most throughout the time series.

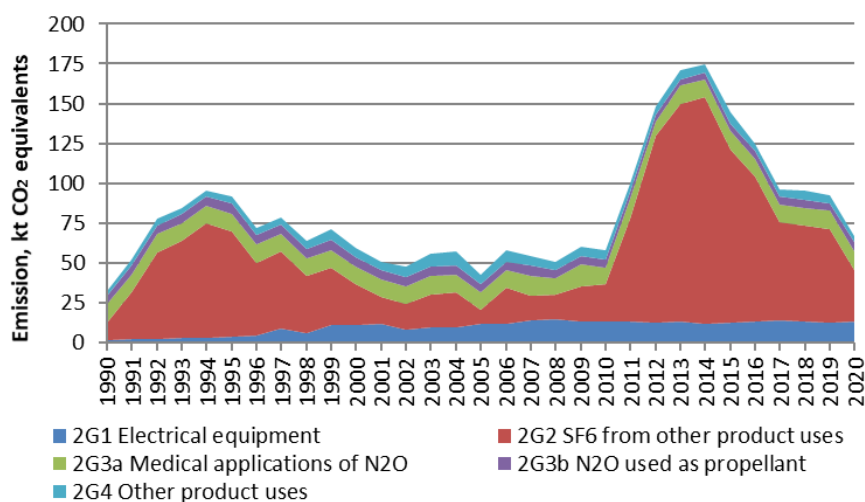

Figure 4.8.1 Emission of CO₂ equivalents from the individual source categories compiling 2G *Other Product Manufacture and Use*.

4.8.3 Electrical equipment

Use of electrical equipment (2G1b) is the only source relevant for the Danish inventories in the sub sector of 2G1 *Electrical equipment*.

Methodology

High voltage power switches are filled or refilled with SF₆, either for new installation or during service and repair. Filling is usually carried out on new installations and a smaller proportion of the consumption of SF₆ is due to re-filling.

The methodology uses annual data from importers' statistics with detailed information on the use of the gas. This corresponds to the country-level mass-balance Tier 3c methodology of IPCC (2006). A release of 5 per cent on filling with new gas and a gradual release of 0.5 per cent from the stock are applied. Both figures are averages, covering normal operation and failure/accidents.

No emissions are assumed to result from disposal since the used SF₆ is drawn off from the power switches and re-used internally by the sole Danish supplier (Siemens) or appropriately disposed of through waste collection schemes. The notation key used for the activity data for the amount of SF₆ remaining in products at decommissioning of electrical equipment in the CRF is therefore "not occurring" (NO).

Activity data

The data collection is described in the Chapter 4.7.3 General methodology.

Information on consumption of SF₆ in high-voltage power switches is derived from importers' sales reports (gas or gas-containing products). The importers account for 100% of the Danish sales of SF₆ for this purpose.

The electricity sector also provides information on the installation of new plants and thus whether the stock is increasing.

Emission factors

The applied emission factors are presented in Table 4.8.1. Special attention has been given to use of SF₆ as insulation in high-voltage plants (Poulsen, 2001; ELTRA, 2004).

Table 4.8.1 Applied emission factors for other processes (Poulsen, 2021).

	Consumption/ filling	Stock, per annum	Disposal	Lifetime
Insulation gas in high voltage switches	5 %	0.5 %	0 %	- ¹

¹ Lifetime unknown.

Emission trends

Figure 4.8.2 presents the emissions of SF₆ from electrical equipment.

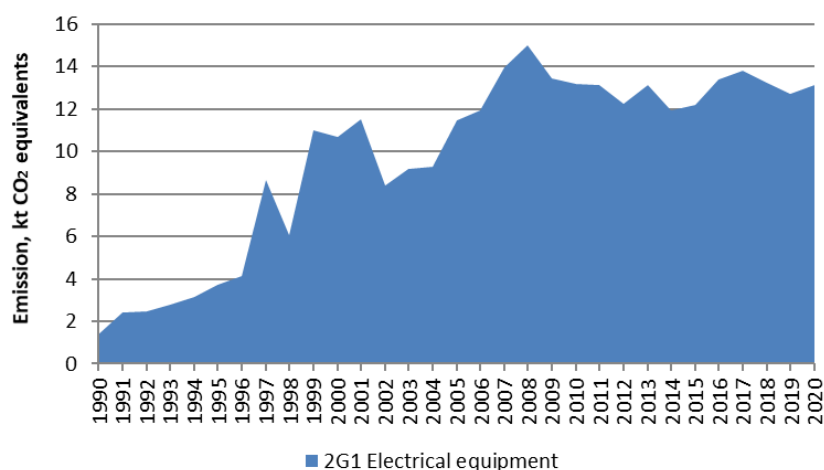

Figure 4.8.2 Emissions from SF₆ from electrical equipment.

The trend in emissions from use of SF₆ in electrical equipment has been increasing. However, significant inter-annual variations occur depending on the specific activity level in a given year.

4.8.4 SF₆ from other product use

2G2 SF₆ from other product use consists of the following subcategories:

- Consumption of SF₆ in running shoes
- Consumption of SF₆ in laboratories
- Consumption of SF₆ in double glazed windows

An overview of when emissions from these three sources occurred are available in Table 4.8.2 below.

Table 4.8.2 Occurrence of emissions from the sources compiling 2G2.

	From manufacture	From stocks	From disposal
Running shoes	-	-	1995-2003
Laboratories	1990-1997, 2001-2004, 2006-2020	-	-
Windows	1991-2001	1991-2020	2011-2020

Methodology

A mass balance approach is used for laboratory use of SF₆. For double glazed windows the default Tier 2 IPCC methodology is used with country-specific emission factor. For more information, please refer to Poulsen (2022).

Consumption of SF₆ in laboratories includes consumption for a particle accelerator, a radiotherapy device, electron microscopes, plasma erosion in connection with the manufacture of microchips in clean-room laboratories and to a limited extend analytical purposes. Importers/suppliers of SF₆ have been questioned with regard to their knowledge of SF₆ consumption in laboratories, but no further details could be obtained. The yearly consumption reached a maximum of 1.1 tonnes of SF₆ in 2013 and is below 0.8 tonnes for all other years in the time series. It is therefore not considered relevant to introduce national emission factors for e.g. particle accelerators. As soon as individual emission factors are available in the Guidelines, Denmark will include these in the submission. But for now, consumption of SF₆ for these special purposes are reported as part of the consumption in laboratories.

Use of SF₆ in double-glazed windows was phased out in 2002, however, there are still emissions from stock in existing double-glazed windows in Danish buildings. The stock is estimated from consumption data from Danish producers of double-glazed windows 1991-2001 and lifetime for double-glazed windows are determined to 20 years.

Activity data

The data collection is described in the Chapter 4.7.3 General methodology.

Information on consumption of SF₆ in double glazing is derived from importers' sales reports to the application area. The importers account for 100% of the Danish sales of SF₆ for double glazing. In addition, the largest producer of windows in Denmark has provided consumption data, with which import information is verified.

Importers have estimated imports to Denmark of SF₆ in training footwear.

Emission factors

The applied emission factors are presented in Table 4.8.3.

Table 4.8.3 Applied emission factors for SF₆ from other product use (Poulsen, 2022).

	Consumption	Stock	Lifetime
Laboratories	100 %		
Insulation gas in double glazed windows	15 %	1 % annual	20 years
Shock-absorbing in Nike Air training footwear	- ¹	- ²	5 years

¹ No emission from production in Denmark.

² Yearly emissions have been estimated to 0.11 t in 1995-2003.

80 % of the content filled into new manufactured double glazed windows is assumed to be disposed at decommissioning.

Emission trends

Figure 4.8.3 presents the emissions of SF₆ from shoes, double glazed windows and other uses (laboratories etc.).

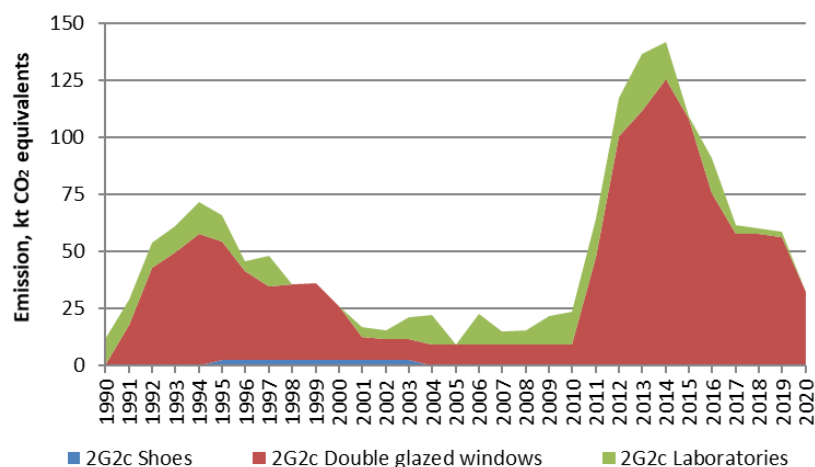

Figure 4.8.3 Emissions from SF₆ from other product uses.

Double-glazed windows using SF₆ was introduced in 1991 and ceased 10 years later. While there is annual emissions, the lifetime is assumed to be 20 years meaning that all remaining SF₆ contained in the windows is assumed to be emitted 20 years after the last production, i.e. starting from 2011. Emissions of SF₆ from this source is therefore high from 2011 (where the first windows are scrapped) and the following 10 years. However, since the use of SF₆ in double glazed windows was banned in 2002, by 2021 all emissions are assumed to have taken place.

4.8.5 Medical applications of N₂O

The category *Medical applications* of N₂O (CRF 2G3a) covers the following SNAP-code:

- 06 05 01 Anaesthesia

Methodology

N₂O has been used as anaesthetics for more than a hundred years but has also had other smaller applications in newer times. N₂O in this source category is predominantly used as anaesthesia and a small amount is used as fuel in race cars and in chemical laboratories.

In the mid-1990s, introduction of air quality limit values for N₂O together with requirements of expensive extraction systems reduced the application of N₂O for anaesthetics at smaller facilities like dentists.

Five companies sell N₂O in Denmark and only one company produces N₂O. N₂O is primarily used in anaesthesia by hospitals, dentists and veterinarians and in minor use in laboratories, racing cars and in the production of electronics. Due to confidentiality, no data on produced amount are available and thus the emissions related to N₂O production are unknown. For 2005-2012, sold amounts are obtained from the respective distributors and the produced amount is estimated from communication with the company. For the remaining years, data are estimated.

Activity data

Data on total sold and estimated produced N₂O for sale in Denmark is only available for the years 2005-2012, activity data for the years 1990-2004 and 2013-2019 have therefore been estimated as the average value of 2005-2012. Activity data for the time series are presented in Table 4.8.4.

Table 4.8.4 Activity data for N₂O mainly used for medical applications, t.

	1990-2004	2005	2006	2007	2008	2009	2010	2011	2012	2013-2020
N ₂ O consumption	38 ¹	37	38	43	33	46	34	42	30	38 ¹

¹⁾ Calculated: average 2005-2012.

Emission factors

An emission factor of 1 is assumed for all uses.

Emission trends

The emission trend for the N₂O emission from medical applications is presented in Figure 4.8.4 below.

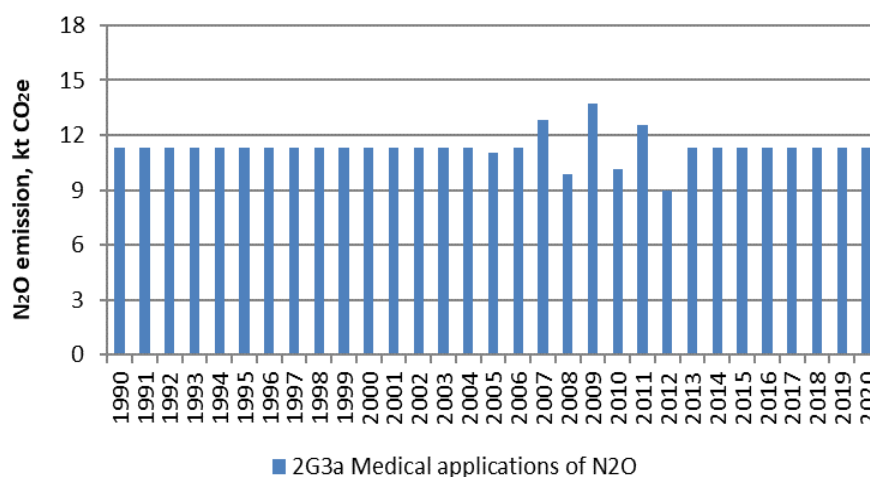

Figure 4.8.4 N₂O emissions from the use of anaesthetics.

Time series consistency and completeness

The methodology is consistent throughout the time series. It is not possible to obtain reliable data prior to 2005, but the source category is considered to be complete although uncertainties going back from 2005 and forth from 2012 are increasing.

4.8.6 N₂O used as propellant for pressure and aerosol products

The category *N₂O used as propellant for pressure and aerosol products* (CRF 2G3b) covers the following SNAP-code:

- 06 05 06 Aerosol cans

Methodology

There is a strong tradition of fresh dairy products in Danish culture and while canned whipped cream is used for e.g. hot beverages in the winter months this product is not widely used.

There are no statistics on production, import/export and/or sales of canned whipped cream in Denmark and the content of propellant is confidential. The consumption of canned whipped cream is therefore estimated as 1 % of the

regular cream sale. Further assumptions made include 5 mass% propellant in a can, 250 ml (250 g) cream per can and 95 % release of N₂O.

Activity data

Data on total sold cream and the estimated sale of canned cream are presented in Table 4.8.5 and in Annex 3C-39.

Table 4.8.5 Consumption of cream in Denmark, t.

	1990	1995	2000	2005	2010	2015	2017	2018	2019	2020
Cream ¹	37378	46279	39380	37333	34835	31772	35373	34683	34575	41713
Canned cream	374	463	394	373	348	318	354	347	346	417

¹Statistics Denmark (2021).

Emission factors

The applied emission factor is 0.0475 tonnes N₂O per tonne canned cream sold; 5 % propellant and 95 % release.

Emission trends

The emission trend for the N₂O used as propellant is available in Annex 3C-40 but is also presented in Figure 4.8.5 below.

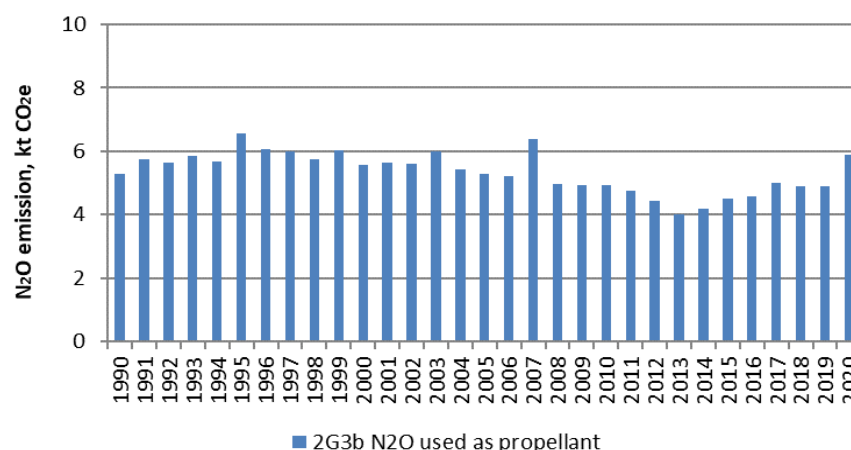

Figure 4.8.5 N₂O emissions from the use of canned whipped cream.

Time series consistency and completeness

The methodology is consistent throughout the time series. The estimate is considered too rough to be certain of completeness. For verification, please refer to Hjelgaard & Nielsen (2018).

4.8.7 Other product uses

The category *Other Product Uses* (CRF 2G4) covers the following SNAP-codes:

- Use of fireworks (SNAP 060601): CO₂, N₂O and CH₄
- Use of tobacco (SNAP 060602): N₂O and CH₄
- Use of charcoal for barbecuing (SNAP 060605): N₂O and CH₄

Methodology

Methane and nitrous oxide emissions are calculated for all three product uses but carbon dioxide is only relevant for fireworks since CO₂ emissions from the two remaining product uses are biogenic.

The applied methodology follows a Tier 2 technology-specific approach from EMEP/EEA (2019)⁸ for calculating emissions from fireworks, tobacco and charcoal for barbeques (BBQ).

Activity data

Activity data are derived from import, export and production data from Statistics Denmark (2021) and are available in Table 4.8.6 and Annex 3C-41.

Table 4.8.6 Activity data for other product uses, kt.

	1990	1995	2000	2005	2010	2015	2017	2018	2019	2020
Fireworks	1.3	3.0	4.9	3.7	5.4	5.8	4.1	6.2	4.2	4.2
Tobacco	13.1	11.7	11.4	10.5	9.5	7.3	7.3	6.0	6.4	5.4
Charcoal for BBQ	7.2	7.9	13.4	14.9	7.8	16.3	7.6	8.1	9.8	6.8

The assumption of the weight of cigarettes and cigars of 1 g and 5 g respectively was made to derive the activity data from Table 4.8.6.

Emission factors

Emission factors for use of fireworks, tobacco and charcoal for BBQ are found through literature studies and are presented in Table 4.8.7.

Table 4.8.7 Emission factors for other product uses.

	Unit	Fireworks ¹	Tobacco ²	BBQ ³
CO ₂	kg/t	43.3	NA	NA
N ₂ O	kg/t	1.94	0.06	0.03
CH ₄	kg/t	0.83	3.2	5.9

¹ Netherlands National Water Board (2008).

² Emission factors for wood (111A) in residential plants (1A4b i), SNAP 020200, the energy content used in the calculation is the average of wood pills and wood waste (16.1 GJ/t).

³ IPCC (2006), calculated using default EFs⁹ a net calorific value¹⁰.

Emission trends

The emission trend for the greenhouse gases from other product uses is available in Annex 3C-42 and in Figure 4.8.6 below.

⁸ 2.D.3.i- 2.G Other solvent and product use, Chapter 3.3 Tier 2 technology-specific approach.

⁹ Volume 2: Energy, Chapter 2.3.2.1 Stationary combustion, Tier 1, Table 2.4, page 2.21, solid biofuels, charcoal.

¹⁰ Volume 2: Energy, Chapter 1.4.1.3 Introduction, Activity data sources, Table 1.2, page 1.19, solid biofuels, charcoal.

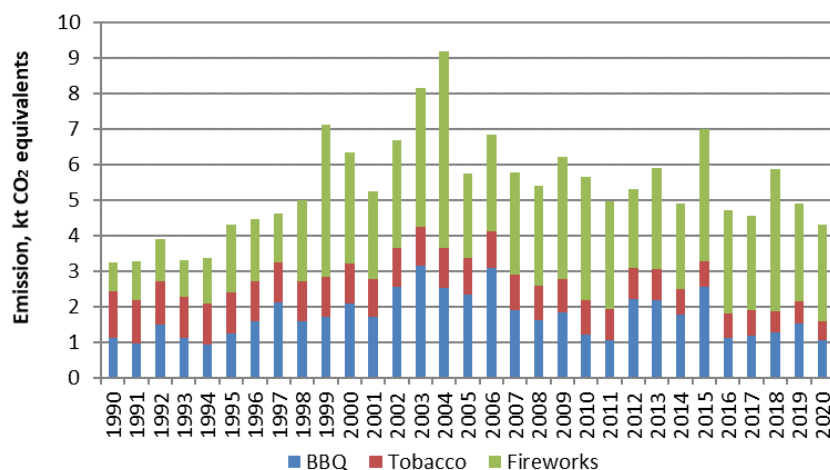

Figure 4.8.6 Greenhouse gas emissions from other product uses.

The consumption of charcoal for BBQs is highly influenced by the summer season weather and the number of smokers has been decreasing throughout the time series.

For fireworks, two peaks are visible in the time series, the peak in 1999 is caused by the celebration of the new millennium and the peak in 2004 by the Seest incident where 284 t net explosive mass (NEM) corresponding to a gross weight of about 1,500 t of fireworks exploded (Report Seest, 2005). From 2005, the new restrictions put on fireworks meant a lower general consumption than before 2004, but the increasing trend continued.

Time series consistency and completeness

Activity data for fireworks are based on import/export data. There is no firework production industry in Denmark and the use of illegal products is assumed negligible. Cross-border shopping of fireworks is also considered negligible since most fireworks from e.g. Germany is illegal in Denmark due to the strict Danish laws on the content of net explosive mass (NEM).

Activity data for tobacco includes cross-border shopping. Data for cross-border shopping is known for 2000-2016 and estimated for the remaining years of the time series. From 2000 to 2016 the cross-border shopping of tobacco decreased from 14 % of retail sale to 8 % in 2016. Cross-border shopping is highly influenced by regulations in the Danish tax system and on e.g. the closure of borders in 2020 caused by the global pandemic of covid-19.

The activity data for charcoal for barbecues are determined from import/export data and includes:

- Charcoal, including coal of nutshells or nuts, also agglomerated
- Bamboo, including coal of nutshells or nuts, also agglomerated (except for medical use, charcoal mixed with incense, activated charcoal and charcoal for drawing)
- Charcoal, including coal of nutshells or nuts, also agglomerated (except bamboo, charcoal dosed or packaged as medicines, charcoal mixed with incense, activated charcoal and charcoal for drawing).

The product called Heat Beads® BBQ briquettes consist of a certain blend of hardwood charcoal and mineral carbon made by carbonising brown coal and is therefore emitting some non-biogenic CO₂. Due to confidentiality it is not possible to determine neither the market share of this product nor the share

of non-biogenic CO₂ emitted from the product. The amount of non-biogenic CO₂ from barbecuing is assumed to be negligible. It is further more assumed that the cross-border shopping of charcoal is negligible.

The time series is considered to be complete for the included sources, the time series is also considered consistent.

4.9 Uncertainty

4.9.1 Uncertainty input

The source specific uncertainties for industrial processes and product uses are presented in Table 4.9.1. The uncertainties are based on IPCC (2006) combined with assessment of the individual processes.

Mineral Industry

The single Danish producer of cement has delivered the activity data for production as well as calculated the emission factor based on quality measurements. For activity data, there is a shift in methodology from 1997 to 1998. Prior to 1998 activity data are derived by the Tier 2 (1-2 % uncertainty) methodology for grey cement production and the Tier 1 (<35 % uncertainty) for white cement production (20-25 % of total production). Activity data have fulfilled the Tier 3 methodology since 1998 and is assumed to have an uncertainty of 1 %. Since uncertainties cannot vary over time in Approach 1 uncertainty calculations, the activity data uncertainty is assumed to be 2 % for the entire time series. The estimation of emission factors fulfils the Tier 3 methodology for the entire time series and uncertainties are therefore assumed to be 2 %.

The activity data for production of lime, including non-marketed lime in the sugar production, are based on information compiled by Statistics Denmark. The uncertainty for the entire time series is assumed to be 1 % for activity data. The emission factor for marketed lime production cover many producers and a variety of high calcium products, assumptions that influence the uncertainty includes the assumptions of no impurities, 100 % calcination and for sugar production also the assumptions on the lime consumption and sugar content in beets. Since 2006 and the introduction of EU-ETS data, the uncertainty decreased as many of the mentioned assumptions were no longer needed, the combined uncertainty for emission factors are estimated to be 4 %.

The activity data uncertainty associated with glass production (including glass wool production) are low for recent years (EU-ETS data) but higher for historic years (carbonate data were not available for 1990-1996 and were therefore estimated for these years), since uncertainties cannot vary over time in Approach 1 calculations, activity data uncertainties are assumed to be 1 % for the entire time series. Uncertainties associated with the emission factors from glass production are low. Denmark uses the Tier 3 methodology and therefore stoichiometric CO₂ factors, some uncertainty is however connected to assuming a calcination factor of 1, and the overall emission factor uncertainty is therefore estimated to be 2 %.

The activity data for production of ceramics are based on information compiled by Statistics Denmark and EU-ETS and the uncertainty is assumed to be 5 % (Tier 2). The emission factor is based on stoichiometric relations and the assumption of full calcination; the uncertainty is assumed to be 2 %.

The CO₂ emission from other uses of soda ash is calculated based on national statistics and the stoichiometric emission factor for soda ash (Na₂CO₃) assuming the calcination factor of 1. Uncertainties are assumed to be 5 % and 2 % for activity data and emission factor respectively.

The category “Other Process Uses of Carbonates” in the Danish inventory includes flue gas desulphurisation and stone wool production. The activity data uncertainty for flue gas desulphurisation is assumed to be 10 %. For stone wool the activity data uncertainty is low for recent years (EU-ETS data) but higher for historic years (calculated/estimated), the uncertainties are assumed to be 2% and 15 % respectively. The overall activity data uncertainties for other process uses of carbonates are assumed to be 4 %. The uncertainty of the stoichiometric emission factors for both source categories is assumed to be 2 %.

Chemical Industry

The producers have registered the production of nitric acid during many years and, therefore, the activity data uncertainty is assumed to be 2 %. The measurement of N₂O is problematic and is only carried out for one year. Therefore, the emission factor uncertainty is assumed to be 25 %.

The uncertainty for the activity data as well as for the emission factor is assumed to be 5 % for production of catalysts/fertilisers.

Metal Industry

The uncertainty for the activity data and emission factor is assumed to be 5 % and 10 % respectively for production of secondary steel.

The uncertainty for the activity data and emission factor is assumed to be 10 % and 30 % respectively for production of magnesium (SF₆) and 10 % and 50 % respectively for lead production.

Non-Energy Products from Fuels and Solvent Use

Emissions from consumption of lubricant oil is derived from the energy statistics and standard emission factors. Uncertainties are assumed to be 5 % and 10 % respectively for activity data and emission factors.

For paraffin wax use the activity data are known for the entire time series (Statistics Denmark) and emission factors from literature. The fraction of candles made from beeswax is unknown, beeswax candles emit biogenic CO₂. Candles produced and sold at e.g. souvenir shops (less than 10 employees) are not included in the activity data from Statistics Denmark. Uncertainties are assumed to be 10 % and 20 % respectively for the two data sets.

Important uncertainty issues related to the mass-balance approach used for solvent use are: (i) Identification of pollutants that qualify as NMVOCs (The definition in Directive (1999) is used) as it is possible that relevant pollutants are not included, e.g. pollutants that are not listed with their name in Statistics Denmark but as a product. (ii) Distribution of solvent consumption between appliances. Although the total consumption is set, a change in distribution of consumption between industrial sectors and households will affect the total emissions, as different emission factors are applied in industry and households, respectively. Uncertainties are assumed to be 10 % for activity data and 15 % for emission factors, except for “other use of solvents and related activities” where the emission factor uncertainty is set at 20 %.

While the activity data for the use of asphalt products are known for the entire time series from Statistics Denmark (uncertainty set at 5 %), the emission factors are calculated using a number of assumptions (uncertainty set at 75 %).

Activity data for urea based catalysts are calculated by the COPERT 5 model. The emission factor includes a number of assumptions. Uncertainties are assumed to be 5 % and 10 % for activity data and emission factors respectively.

Product Uses as Substitutes for Ozone depleting Substances

Uncertainty varies from substance to substance. Uncertainty is highest for HFC-134a due to its widespread application in products imported and exported. The largest uncertainty in the analysis of substances by application areas is assessed to concern the breakdown of consumption of HFC-404A and HFC-134a between commercial stationary refrigerators and mobile A/C systems. This breakdown is significant for the short-term (about 5 years) emissions calculations, but will balance in the long term. This is because the breakdown is only significant for the rate at which emissions are released. (Poulsen, 2022)

The emission of F-gases is dominated by emissions from refrigeration equipment and therefore, the uncertainties assumed for this sector will be used for all the F-gases. The IPCC propose an uncertainty at 30-40 % for regional estimates. However, Danish statistics have been developed over many years and, therefore the uncertainty on activity data is assumed to be 10 %. The uncertainty on the emission factor is assumed to be 50 %. The base year for F-gases for Denmark is 1995.

Other Product Manufacture and Use

The uncertainty of N₂O used for medical applications is assumed to be 25 % for activity data and 20 % for the emission factor.

The uncertainty of N₂O used as propellant for pressure and aerosol products is estimated to be 100 % for activity data and 150 % for the emission factor.

The main issues leading to uncertainties for activity data for “Other Product Use” are collection of data for quantifying production, import and export of products. Some data, like private import (cross-border shopping) of fireworks, are not available. Other missing data like the composition of mineral containing charcoal for barbequing are unobtainable due to confidentiality. The uncertainty for activity data for all three product uses (fireworks, tobacco and BBQs) is estimated to be 5 %. Reliable emission factors are difficult to obtain for the other product use categories. Some chosen emission factors apply to countries that are not directly comparable to Denmark, and hereby is introduced an increased uncertainty. The uncertainties for emission factors are estimated to be 50 % for fireworks, 50 % for tobacco and 100 % for barbeques.

4.9.2 Approach 1 uncertainty

All uncertainty input values are discussed in Section 4.9.1 above. Table 4.9.1 presents the uncertainty inputs for activity data and emission factors and the calculated total emission and uncertainty for Approach 1 for the individual pollutants. The total greenhouse gas emission from the IPPU sector in 2020 is 1925 kt CO₂ equivalents and the calculated Approach 1 uncertainty for the year is 8.8 %. The trend decreases with 27.7 % during the time series and the trend uncertainty is 9.4 %.

Table 4.9.1 Input uncertainties and calculated Approach 1 emission and uncertainties.

CRF Category	Activity data uncertainty	Emission factor uncertainty					
		CO ₂	CH ₄	N ₂ O	HFCs ²	PFCs ²	SF ₆ ²
	%	%	%	%	%	%	%
2A1 Cement production	2	2					
2A2 Lime production	1	4					
2A3 Glass production	1	2					
2A4a Ceramics	5	2					
2A4b Other uses of soda ash	5	2					
2A4d Other process uses of carbonates	4	2					
2B2 Nitric acid production ¹	2			25			
2B10 Catalysts/fertiliser production	5	5					
2C1 Iron and steel production	5	10					
2C4 Magnesium production	10						30
2C5 Secondary lead production	10	50					
2D1 Lubricant use	5	10					
2D2 Paraffin wax use	10	20	20	20			
2D3 Paint application	10	15					
2D3 Degreasing, dry cleaning and electronics	10	15					
2D3 Chemical products manufacturing or processing	10	15					
2D3 Other use of solvents and related activities	10	20					
2D3 Printing industry	10	15					
2D3 Domestic solvent use (other than paint applicat.)	10	15					
2D3 Road paving with asphalt	5	75	75				
2D3 Asphalt roofing	5	75					
2D3 Urea from fuel consumption	5	10					
2E5 Other electronics industry	10					50	
2F1 Refrigeration and air conditioning	10				50	50	
2F2 Foam blowing agents	10				50		
2F4 Aerosols	10				50		
2F5 Solvents ³	-						
2G1 Electrical equipment	10						50
2G2 SF ₆ from other product use	10						50
2G3a Medical application	25			20			
2G3b Propellant for pressure and aerosol products	100			150			
2G4 Fireworks	5	50	50	50			
2G4 Tobacco	5		50	50			
2G4 Barbeques	5		100	100			
Emission 2020, kt		1523	0.1	0.1	335 ⁴	0.01 ⁴	45.5 ⁴
Overall uncertainty in 2020, %		2.3	53.6	56.6	49.2	51.0	39.2
Trend 1990-2020 (1995-2020), %		19.2	-17.9	-98.0	29.7	98.9	-56.1
Trend uncertainty, %		2.5	12.4	1.4	74.9	0.2	8.7

¹ The production closed down in the middle of 2004.

² The base year for F-gases is for Denmark 1995.

³ Uncertainties are not calculated for this source category because the activity occurs in neither 1995 nor 2020.

⁴ CO₂ equivalents.

4.10 Quality assurance/quality control (QA/QC)

4.10.1 Internal QA/QC

The approach used for quality assurance/quality control (QA/QC) is presented in Chapter 1.6; see also Nielsen et al. (2012). The present chapter presents QA/QC considerations for industrial processes and product use based on a series of Points of Measuring (PMs); see Chapter 1.6.

Data Storage level 1	1. Accuracy	DS.1.1.1	General level of uncertainty for every dataset including the reasoning for the specific values.
----------------------	-------------	----------	---

The uncertainty assessment has been performed on Approach 1 level by using default and country specific uncertainty factors. The applied uncertainty factors are presented in Chapter 4.9.

The sources of data described in the methodology sections and in DS.1.2.1 and DS.1.3.1 are used. It is the accuracy of these data that define the uncertainty of the inventory calculations. Any data value obtained from Statistics Denmark and SPIN are given as a single point estimate and no probability range or uncertainty is associated with this value. Information from reports is sometimes given in ranges. Uncertainties are therefore assessed from DCE judgement and guidebook estimates.

Data Storage level 1	2.Comparability	DS.1.2.1	Comparability of the emission factors/calculation parameters with data from international guidelines, and evaluation of major discrepancies.
----------------------	-----------------	----------	--

Comparability of the data has not been performed at “Data Storage level 1”. However, investigation of comparability at CRF level is in progress and is described in verification sections under each source category in Hjelgaard & Nielsen (2018) as they are performed.

The applied data sets are presented in Table 4.10.1.

Production and import/export data from Statistics Denmark for single products/chemicals can be directly compared with data from Eurostat for other countries. This has been done for a few chosen products/chemicals and countries. Furthermore, chosen Danish data from Eurostat have been validated with data from Statistics Denmark in order to check the consistency in data transfer from national to international databases.

Use categories for chemicals in products are found from the Nordic SPIN database. Data for all Nordic countries are available and reported uniformly. For chosen chemicals a comparison of chemical amounts and use has been made between countries.

Regarding Non-energy products from fuels and solvent use, a joint Nordic project funded by the Nordic Council of Ministers has been used on methodological issues and for emission factors (Fauser et al., 2009).

Data Storage level 1	3.Completeness	DS.1.3.1	Ensuring that the best possible national data for all sources are included, by setting down the reasoning behind the selection of datasets.
----------------------	----------------	----------	---

The data sources - in general - can be grouped as follows:

- Company specific environmental reports.
- Personal communication with individual companies.
- Company specific information compiled by Danish Energy Agency in relation to the EU-ETS.
- Industrial organisations.
- Statistics Denmark.
- SPIN database.

- Secondary literature.
- IPCC guidelines.

The environmental reports contribute with company-specific emission factors, technical information and, in some cases, activity data. The environmental reports are primarily used for large companies and, for some companies, are supplemented with information from personal contacts, especially for completion of the time series for the years before the legal requirement to prepare environmental reports (i.e. prior to 1996) and after the removal of the requirement (i.e. after 2014).

For reports from and personal contacts with industrial branches it is fundamental to have information from the industrial branches that have direct contact with the activities, e.g. chemicals and products of interest. The information can be in the form of personal communication, but also reported surveys are of great importance. In contrast to the more generic approach of collecting information from large databases, the expert information from industries may give valuable information on specific production processes, chemicals and/or products and industrial activities. By considering both sources a verification as well as optimum reliability and accuracy is obtained.

Statistics Denmark is often used as source for activity data as they are able to provide consistent data for the entire time series. In the cases where the statistics do not contain transparent data, statistics from industrial organisations are used to generate the required activity data. Statistics Denmark is used as the main database for collecting data on production, import and export of products, single chemicals, chemical groups and in some cases surrogate data. In order to obtain a uniform and unique set of data, it is important that the data for e.g. production of single chemicals is in the same reporting format and from the same source. The amount of data is very comprehensive and is linked with the data present in Eurostat whenever possible. The database covers all sectors and is regarded as complete on a national level.

Nordic SPIN database provides data on the use of chemicals in Norway, Sweden, Denmark and Finland. It is financed by the Nordic Council of Ministers, Chemical group, and the data is supplied by the product registries of the contributing countries. The Danish product register (PROBAS) is a joint register for the WEA and the EPA and comprises a large number of chemicals and products. The information is obtained from registration according to the EPA rules and from scientific studies and surveys and other relevant sources. The product register is the most comprehensive collection of chemical data in products for Denmark and with the availability of data from the other Nordic countries it enables an inter-country comparison. For each chemical the data is reported in a uniform way, which enhances comparability, transparency and consistency.

For some of the processes, the default emission factors are based on chemical equations (stoichiometric) and are, therefore, the best choice. In some cases, the default emission factor has been modified in order to reflect local conditions.

Secondary literature may be used in the interpretation or in disaggregation of the public statistics.

Regarding Non-energy products from fuels and solvent use, the present inventory procedure builds partly on information from the previous Danish solvent emission inventory, which is based on questionnaires to industrial branches. Furthermore, a joint Nordic collaboration on solvent inventories has given important information on methods and data.

Data Storage level 1	4.Consistency	DS.1.4.1	The original external data has to be archived with proper reference.
----------------------	---------------	----------	--

The original data files are archived in the following folder:

O:\Tech_ENVS-Luft-Emi\Inventory\2020\2_IPPU\Level_1a_Storage.

All data extracted from the internet (e.g. Statistics Denmark, SPIN, online PRTR) are saved as original copies in their original form. Specific information from industries and experts are saved as e-mails and reports.

Data Storage level 1	6.Robustness	DS.1.6.1	Explicit agreements between the external institution holding the data and NERI about the condition of delivery.
----------------------	--------------	----------	---

An agreement regarding inclusion of information - compiled by Danish Energy Agency for EU-ETS - in the Danish greenhouse gas inventory has been signed. The implementation of this information has been introduced for production of cement, lime production, glass production, glass wool production, bricks, expanded clay products, flue gas desulphurisation and stone wool production.

Data Storage level 1	7.Transparency	DS.1.7.1	Listing of all archived datasets and external contacts.
----------------------	----------------	----------	---

The datasets applied are presented in Table 4.10.1. For the reasoning behind their selection, see DS.1.3.1.

Table 4.10.1 Applied datasets (archived in: O:\Tech_ENVS-Luft-Emi\Inventory\2020\2_IPPU\Level_1a_Storage).

\Grønne regnskaber\	Ardagh Glass Holmegaard GR 2013 Danisco Assens GR 2007 Faxe Kalk GR 2013 Haldor Topsøe GR 2012 Kemira GR 2005 Nordic Sugar Nakskov Miljøberetning 2012 Nordic Sugar Nykøbing GR 2009 Rockwool Miljøreddegørelse 2013 Saint-Gobain Isover GR 2014 Stålvaseværket GR 2000 Aalborg Portland 2019 Miljøreddegørelse
\CO ₂ kvote indberetninger\	Ceramics (folder with 17 files) Ardagh Glass Holmegaard EU-ETS Faxe Kalk EU-ETS Haldor Topsøe EU-ETS Isover EU-ETS Nordic Sugar Nakskov EU-ETS Rockwool Doense EU-ETS Rockwool Vamdrup EU-ETS Aalborg Portland EU-ETS
\Danmarks Statistik\	Afgrøder Animal feed Asphalt BBQ Beverages Bread Bricks and tiles Cast iron Catalysts Chemical ingredients Coffee Construction, road Construction, rådata Dolomite and lime Expanded clay Fats Fireworks Fløde Folketal Meat Paraffin wax Rødgods Slaughterhouse waste Soda ash Solvents Stenbrud og minedrift Stenuld Sugar production Tobacco

Data Processing level 1	1. Accuracy	DP.1.1.1	Uncertainty assessment for every data source not part of DS.1.1.1 as input to Data Storage level 2 in relation to type and scale of variability.
-------------------------	-------------	----------	--

The uncertainty assessment has been performed on Approach 1 level, assuming a normal distribution of activity data as well as emission data, by application of default uncertainty factors. Therefore, no considerations regarding distribution or type of variability have been performed.

Data Processing level 1	2. Comparability	DP.1.2.1	The methodologies have to follow the international guidelines suggested by UNFCCC and IPCC.
-------------------------	------------------	----------	---

All methodologies follow UNFCCC and IPCC unless better national methodologies have been identified.

Data Processing level 1	3. Completeness	DP.1.3.1	Identification of data gaps with regard to data sources that could improve quantitative knowledge.
-------------------------	-----------------	----------	--

This is discussed for each source category individually in the “Time series consistency and completeness” chapters.

Data Processing level 1	4. Consistency	DP.1.4.1	Documentation and reasoning of methodological changes during the time series and the qualitative assessment of the impact on time series consistency.
-------------------------	----------------	----------	---

Recalculations are described in the chapter 4.11. A manual log is included in the tool used for data processing at Data Processing level 2. This log also includes changes on Data Processing level 1.

Data Processing level 1	5. Correctness	DP.1.5.2	Verification of calculation results using time series.
-------------------------	----------------	----------	--

The calculations are verified by checking the time series.

Data Processing level 1	5. Correctness	DP.1.5.3	Verification of calculation results using other measures.
-------------------------	----------------	----------	---

The calculation of results is verified using other measures where other measurements are available. Some are presented in the “Verification” sections, in the sector report (Hjelgaard & Nielsen, 2018) and some are only used internally.

Data Processing level 1	7. Transparency	DP.1.7.1	The calculation principle, the equations used and the assumptions made must be described.
-------------------------	-----------------	----------	---

The calculation principles and equations are based on the methodology presented by the IPCC. A detailed description can be found in the sector report for industrial processes and product use (Hjelgaard & Nielsen, 2018).

Data Processing level 1	7. Transparency	DP.1.7.2	Clear reference to dataset at Data Storage level 1
-------------------------	-----------------	----------	--

The calculation files contain links to the original data files.

Data Processing level 1	7. Transparency	DP.1.7.3	A manual log to collect information about recalculations.
-------------------------	-----------------	----------	---

A log on information about recalculation is included in CollectER.

Data Processing level 2	5. Correctness	DS.2.5.1	Check if a correct data import to level 2 has been made
-------------------------	----------------	----------	---

The sector report for industrial processes and product use (Hjelgaard & Nielsen, 2018) presents the connection between the datasets on Data Storage level 1 and Data Processing level 2. Individual calculations are used to check the output of the data processing tool used at Data Processing level 2.

Data Storage level 4	4. Consistency	DS.4.4.3	The IEFs from the CRF are checked regarding both level and trend. The level is compared to relevant emission factors to ensure correctness. Large dips/jumps in the time series are explained.
----------------------	----------------	----------	--

The implied emission factors (IEFs) are checked by using a tool developed especially for that purpose and outliers are explained.

Data Storage level 4	4. Correctness	DS.4.5.2	Check that additional information and information related to land-use changes has been correctly aggregated compared to the individual submissions of Denmark and Greenland.
----------------------	----------------	----------	--

The aggregated submission for Denmark and Greenland is checked against the individual submissions for Denmark and Greenland.

4.10.2 External QA/QC

External QA/QC is described for one source: cement production.

Cement production

Aalborg Portland has an environmental management system that meets the requirements in DS/ISO 14001, EMAS etc. (Aalborg Portland, 2013b). The environmental management system is part of an integrated process management system. The system is certified according to the standards by the accredited body: Danish Standards. Information on raw material consumption as well as internal recycling is compiled in an environmental database. Some pollutants (NO_x, SO₂, CO and TSP) are measured continuously. Emission of CO₂ is calculated based on (fuel and) raw material consumption and raw material flow according to an approved CO₂ emission plan (EU-ETS). The CO₂ emission plan has to fulfil the requirements in the guidelines developed by EU (EU Commission, 2018).

4.11 Recalculations

Table 4.11.1 shows recalculations of the CO₂, CH₄, N₂O, HFCs, PFCs and SF₆ emissions. Emissions reported this year have been compared to emissions reported last year.

Table 4.11.1 Recalculations, %.

	1990	1995	2000	2005	2010	2015	2016	2017	2018	2019
CO ₂	-0.04	-0.11	-0.05	0.06	-0.01	-0.02	-0.02	-0.02	-0.03	0.11
CH ₄	-	-	-	-	-	-	-	-0.41	0.77	-0.59
N ₂ O	-	-	-	-	-	-	-	-0.01	-0.03	0.03
HFCs		-	-	-	-	-	-	-	-	-
PFCs		-	-	-	-	-	-	-	-	-
SF ₆		-	-	-	-	-	-	-	-	-
GHG	-0.02	-0.06	-0.02	0.04	-0.01	-0.02	-0.01	-0.02	-0.02	0.08

Sector specific recalculations for 2019 are shown in Table 4.11.2, subcategories with no recalculations are not displayed in the table, e.g. 2A1 Cement production. The main recalculations are discussed for each sub-sector below.

Table 4.11.2 Recalculations for industrial processes and product use, 2019.

	CO ₂ , kt CO ₂	CH ₄ , t CO ₂ eqv	N ₂ O t CO ₂ eqv	F-gas kt CO ₂ eqv	CO ₂ %	CH ₄ , %	N ₂ O %	F-gas %
2A Mineral industry	-0.12				-0.01			
4a Ceramics	-0.12				-0.26			
2B Chemical industry	0.00002				0.002			
10 Production of catalysts	0.00002				0.002			
2C Metal industry	No RC				No RC			
2D Non-energy products from fuels and solvent use	1.66	0.08	0.02		1.04	0.45	3.28	
2 Paraffin wax use	1.94	0.08	0.02		3.28	3.28	3.28	
3 Solvent use	-0.28				-0.48			
3 Asphalt roofing	0.0001				0.37			
3 Urea used in catalysts	-0.0003				-0.003			
2E Electronics industry				No RC				No RC
2F Product Uses as Substitutes for ODS				No RC				No RC
2G Other product manufacture and use	0.0004	-0.67	0.004	No RC	0.21	-0.82	0.01	No RC
4 Charcoal		-0.01	-0.00005			-0.02	-0.02	
4 Tobacco		-0.67	-0.01			-3.18	-3.18	
4 Fireworks	0.0004	0.01	0.02		0.21	0.21	0.21	

No RC: No recalculations.

4.11.1 Mineral industry

New activity data are made available for stone wool production. Inclusion of these new data in the calculation method result in some recalculations for 1990-2004; -2.0 kt to +0.6 kt CO₂. An update from Statistics Denmark result in a small decrease of 0.12 kt CO₂ from expanded clay production in 2019.

4.11.2 Chemical industry

The only recalculation made in Chemical industry, is an increase of 24 kg CO₂ (+0.002 %) in 2019. This recalculation is a result of an update of data from Statistics Denmark.

4.11.3 Non-energy products from fuels and solvent use

The majority of recalculations in this category are made for Solvent use (1990-2019). Recalculations also occur for Paraffin wax use (2018-2019) and minor recalculations for Asphalt roofing (2018-2017) and Urea based catalysts (2001-2019). Changes made for Urea based catalysts are caused by the annual update of the traffic model, specifically the change in road work (total km driven) for heavy duty vehicles equipped with SCR catalysts. All other changes made in the Non-energy products from fuels and solvent use (2D) category, are related to updated activity data from Statistics Denmark.

The overall recalculation for category 2D, is between -0.6 kt CO₂ equivalents (-0.3 % of greenhouse gasses from 2D) in 2000 and +1.7 kt CO₂ equivalents (+1.0 % of greenhouse gasses from 2D) in 2019.

4.11.4 Other product manufacture and use

Recalculations were made due to updated activity data published by Statistics Denmark for 2017-2019 concerning the use of fireworks, tobacco and charcoal for barbecuing. All of the recalculations are minor (maximum 0.02 kt CO₂ equivalents per year for the sum of all three categories). The resulting overall recalculations for Other product manufacture and use - other (2G4) are -0.015 kt CO₂ equivalents (2019) to +0.012 kt CO₂ equivalents (2018).

4.12 Improvements

4.12.1 Responses to the review process

The table below contains the recommendations of the most recent UNFCCC review of the Danish greenhouse gas inventory. The table details the status of implementation of the recommendations as well as references to where improvements have been implemented in this report.

A review of the Danish 2020 submission took place in November 2020. At the time of preparing this report, Denmark had not yet received a draft review report. Therefore, the table below represents the latest available report.

Table 4.11.3 Recommendations of the most recent UNFCCC review of the Danish greenhouse gas inventory.				
Para.	CRF	ERT Comment	Denmark's response	Reference
2020 submission (Review report: https://unfccc.int/sites/default/files/resource/arr2020_DNK.pdf)				
I.3	2.F.1 Refrigeration and air conditioning – HFCs	Ensure consistent reporting of the emissions from laboratory freezers in the CRF tables across the time series and include in the NIR an explanation on the methodology used and allocation of the emissions from this subcategory.	This has been implemented	Chapter 4.7.4 Refrigeration and air conditioning
I.7	2.B.10 Other (chemical industry) – CO ₂	<p>The Party reported in its NIR (table 4.1.1, p.294) that it applied the Tier 2 methodology from the 2006 IPCC Guidelines and a plant-specific EF to estimate CO₂ emissions from catalyst production. However, the methodology applied by the Party is not consistent with the Tier 2 methodology provided in the 2006 IPCC Guidelines (vol. 3, chap. 2, equation 2.15) because it does not involve the use of national data on the quantity of limestone and dolomite consumed in the country. Instead, the Party used data from the EU ETS, which is consistent with a country-specific (Tier 3) method, as per the 2006 IPCC Guidelines (vol. 3, chap. 2, p.2.35). During the review, the Party acknowledged that it applied a country-specific methodology and not the Tier 2 methodology provided in the 2006 IPCC Guidelines.</p> <p>The ERT recommends that the Party correctly describe the methodology used for the category by referring to it as a Tier 3 methodology in the relevant text and tables in the NIR.</p>	This has been implemented	Chapters 4.1.1 4.1.1 Methodology overview and 4.3.4 Catalyst production
I.8	2.B.10 Other (chemical industry) – CO ₂	<p>The Party reported in its NIR (section 4.3.4, p.316) that environmental reports were the source of the AD for catalysts and potassium nitrate fertilizer production for 2007–2012. However, the ERT was not able to reproduce the estimates using the information on the AD provided in the NIR. During the review, the Party explained that it used AD on catalyst production provided by Statistics Denmark for this submission, but these were not mentioned in the NIR. The Party shared the AD used in the calculations with the ERT during the review. Denmark also clarified that it calculated the data on potassium nitrate production for 2015–2018 by extrapolation. However, the ERT noted that the Party calculated emissions from potassium nitrate production incorrectly for 2018, as by mistake, it used the extrapolated production AD for 2017, rather than for 2018. This resulted in an underestimation of emissions by 1.44 kt CO₂, which is below the significance threshold as defined in paragraph 37(b) of the UNFCCC Annex I inventory reporting guidelines and for application of an adjustment in accordance with paragraph 80(b) of decision 22/CMP.1 (annex) in conjunction with decision 4/CMP.11.</p> <p>The ERT recommends that the Party recalculate emissions from potassium nitrate production for 2018 using the production AD for 2018 and update the reference in the NIR to the source of the historic AD.</p>	This has been implemented	Chapter 4.3.4 Catalyst production
I.9	2.F.1 Refrigeration and air conditioning – HFC	The IEFs for the HFC-143a product manufacturing factor for commercial refrigeration reported in DNK CRF table 2(II)B-Hs2 for 2017 and 2018 are outliers in terms of the inter-annual variation across the time series. During the review, the Party explained that the significant inter-annual variation in the values reported for the HFC-143a product manufacturing factor for commercial refrigeration for 2017 and 2018 is due to the reporting for Greenland; although emissions related to the category have decreased significantly in mainland Denmark in recent years, emissions from Greenland account for a more significant share of the HFC-143a IEFs calculated for the submissions of Denmark under the Convention and for the first commitment period of the Kyoto Protocol.	This has been implemented	Chapter 4.7.1 Source category description

Para.	CRF	ERT Comment	Denmark's response	Reference
		The ERT recommends that the Party investigate the reasons for the outlier values of the HFC-143a product manufacturing factor for commercial refrigeration reported for 2017 and 2018 and revise them, as necessary, providing a transparent explanation in the NIR if there continues to be significant inter-annual variation in the values reported.		
I.10	2.F.1 Refrigeration and air conditioning – HFC	The HFC-125 IEFs for the product manufacturing factor for commercial refrigeration reported by the Party in DNK CRF table 2(II)B-Hs2 for 2011, 2012, 2013, 2014, 2017 and 2018 are outliers in terms of the inter-annual variation across the time series. During the review, the Party stated that the significant inter-annual variation in the values of IEFs for those years stems from the fact that for 2011 inventory year onward, the Party incorrectly calculated a portion of the emissions from HFC-125 used for commercial refrigeration by using the product manufacturing factor for stationary cooling (0.5 per cent), which is lower than that for commercial refrigeration (1.5 per cent). Denmark explained that this led to a small underestimation of emissions from manufacturing for 2010–2018 and an overestimation in emissions from stocks for 2011–2018, resulting in an overall difference of 0.05–0.63 kt CO ₂ eq, or up to 0.0012 per cent of the national total. The ERT noted that this is below the threshold of significance provided in paragraph 37(b) of the UNFCCC Annex I inventory reporting guidelines and for application of an adjustment in accordance with paragraph 80(b) of decision 22/CMP.1 (annex) in conjunction with decision 4/CMP.11. The ERT recommends that the Party recalculate the emissions for the subcategory for 2010 onward by correcting the product manufacturing factor values used for the calculation of HFC-125 emissions for commercial refrigeration using the correct value of product manufacturing factor.	This has been implemented	CRF tables

4.12.2 Planned improvements

There are currently no planned improvements for the greenhouse gas inventory for industrial processes and product use.

4.13 References

Ardagh, 2012: CO₂-overvågningsplan for Ardagh Glass Holmegaard A/S, CVR nr: 18445042. Driftsleders godkendte overvågningsplan gældende fra 10/12-2012 (In Danish).

Ardagh, 2014: Grønt regnskab for Ardagh Glass Holmegaard A/S 2013, CVR nr. 18445042 (In Danish). Including earlier versions 1997-2012.

Ardagh, 2021: CO₂-opgørelse og afrapportering 2020 (EU-ETS). Ardagh Glass Holmegaard A/S (In Danish). Including earlier versions 2006-2019. Confidential.

Asfaltindustrien, 2003. Asfalt 3/03, Asfalt vore veje. Direktion Ib Frandsen.

Campbell et al., 2021: Lisa Campbell, Julia Toolen, Denise Grubert and Gary Napp. American Petroleum Institute (API), Compendium of Greenhouse Gas Emissions Methodologies for the Natural Gas and Oil Industry, November 2021. Available at:

<https://www.api.org/~media/Files/Policy/ESG/GHG/2021-API-GHG-Compendium-110921.pdf> (07/01-2022).

Danisco Sugar Assens, 2007: Grønt regnskab 2006/2007 Assens.

Danish Energy Agency, 2021: Danish Energy Agency (DEA), the Danish energy statistics for 2020, Available at: <https://ens.dk/en/our-services/statistics-data-key-figures-and-energy-maps/annual-and-monthly-statistics> (07/01-2022).

Directive, 1999: Directive 1999/13/EC of 11 March 1999 on the limitation of emissions of volatile organic compounds due to the use of organic solvents in certain activities and installations, Brüssel, 1999.

ELTRA, 2004: Anvendelse og håndtering af SF₆-gas i højspændingsanlæg over 100kV (use and management of SF₆ in 100kV or more high-voltage plant). ELTRA Memo elt2004-47a of 18 March 2004.

EMEP/EEA, 2019: EMEP/EEA air pollutant emission inventory guidebook 2019, Technical guidance to prepare national emission inventories. Published by the EEA with the CLRTAP Task Force on Emission Inventories and Projections responsible for the technical content of the chapters. Technical report No 13/2019. Available at: <https://www.eea.europa.eu/publications/emep-eea-guidebook-2019> (11/01-2022).

Energinet.dk, 2020: Miljørapport 2020 for dansk el og kraftvarme for statusåret 2019 (in Danish). Available at: <https://energinet.dk/Om-publikationer/Publikationer/Miljoerapport-2020> (07/01-2022).

EU Commission, 2018: Regulations, Commission Implementing Regulation (EU) 2018/2066 of 19 December 2018, on the monitoring and reporting of greenhouse gas emissions pursuant to Directive 2003/87/EC of the European Parliament and of the Council and amending Commission Regulation (EU) No 601/2012 Available at: <https://eur-lex.europa.eu/legal-content/EN/TXT/PDF/?uri=CELEX:32018R2066&from=EN> (04/01-2022).

Fausser et al., 2009: Fausser, P., Saarinen, K., Harðardóttir, K., Kittilsen, M.O., Holmengen, N. & Skårman, T. 2009: Improvement of Nordic Emission Models for Solvent Use in Selected Sectors. TemaNord 2009:556. Nordic Council Of Ministers, Copenhagen.

Faxe Kalk, 2013a: CO₂-overvågningsplan for Faxe Kalk, CVR nr: 20882182. Driftsleders godkendte overvågningsplan gældende fra 01/01-2013 (In Danish).

Faxe Kalk, 2013b: Grønt regnskab 2013, Faxe Kalk A/S. Ovnanlægget Stubberup. Including earlier versions 1996-2012.

Faxe Kalk, 2021: CO₂-udledningsrapport for 2020 (EU-ETS). Faxe Kalk, Ovnanlægget Stubberup (In Danish). Including earlier versions 2007-2019. Confidential.

Haldor Topsøe, 2013: Miljøreddegørelse for katalysatorfabrikken 2012. incl. 1996-2011. (In Danish).

Haldor Topsøe, 2021a: CO₂-udledningsrapport for 2020 (EU-ETS). Haldor Topsøe A/S (In Danish). Including earlier years 2011-2019. Confidential.

Haldor Topsøe, 2021b: PRTR for 2020 for Haldor Topsøe A/S. Including earlier years 2009-2019.

Hals metal, 2021: Personal communication with Carsten Henriksen August 2021.

Hjelgaard & Nielsen., 2018: Hjelgaard, K.H. & Nielsen, O.-K. 2018. Danish emission inventory for industrial processes. Results of inventories up to 2016. Aarhus University, DCE - Danish Centre for Environment and Energy, 192 pp. Scientific Report No. 292. Available at: <http://dce2.au.dk/pub/SR292.pdf> (06/01-2022).

Illerup et al., 1999: Illerup, J.B., Geertinger A.M., Hoffmann, L. & Christiansen, K., Emissionsfaktorer for tungmetaller 1990-1996. Faglig rapport fra DMU, nr. 301. Miljø- og Energiministeriet, Danmarks Miljøundersøgelse 1999 (In Danish).

Imerys, 2021: CO₂-udledningsrapport for 2020 (EU-ETS) for Imerys Industrial Minerals Denmark A/S. Imerys Fur og Imerys Mors (In Danish). Including earlier versions 2006-2019 (Damolin). Confidential.

IPCC, 2006: 2006 IPCC Guidelines for National Greenhouse Gas Inventories. Available at: <http://www.ipcc-nggip.iges.or.jp/public/2006gl/> (07/01-2021).

Jensen & Markussen, 1993: Jensen, A., & Markussen, J. 1993. Forbrug af og forurening med cadmium (Miljøprojekt nr. 213). København: Miljøstyrelsen. (Referred to in Annex 3C-20).

Kemira GrowHow, 2005: Miljø & arbejdsmiljø. Grønt regnskab 2004 (In Danish). Including earlier years 1996-2003.

Lassen et al., 2004: Carsten Lassen, Claus Lübeck Christensen og Susanne Skårup, Cowi A/S, Massestrømsanalyse for bly 2000 - revideret udgave, Miljøprojekt Nr. 917 2004. (Danish). Available at: <https://www2.mst.dk/Udgiv/publikationer/2004/87-7614-231-0/pdf/87-7614-232-9.pdf> (07/01-2022).

Leca, 2021: CO₂-udledningsrapport for 2020 (EU-ETS) for Saint-Gobain Weber A/S, Leca Danmark (In Danish). Including earlier versions 2006-2019. Confidential.

MIM, 1977: Bekendtgørelse om anvendelse af gifte og sundhedsfarlige stoffer til specielt angivne formål. BEK nr. 349 af 16/06/1977 (In Danish). Available at: <https://www.retsinformation.dk/Forms/R0710.aspx?id=48340> (11/01-2022).

MIM, 2002: Bekendtgørelse om regulering af visse industrielle drivhusgasser, Bek. Nr. 552, 02/07 2002. (In Danish) Available at: <https://www.retsinformation.dk/Forms/R0710.aspx?id=12578> (11/01-2022).

MIM, 2015: Bekendtgørelse om begrænsning i anvendelse af visse farlige kemiske stoffer og blandinger til specielt angivne formål. BEK nr. 1388 af 25/11/2015 (In Danish). Available at: <https://www.retsinformation.dk/Forms/R0710.aspx?id=175489> (11/01-2022).

Netherlands National Water Board, 2008, Emission estimates for diffuse sources, Netherlands Emission Inventory, Letting off fireworks, Version dated June 2008, Netherlands National Water Board – Water Unit in cooperation with Deltares and TNO. Available at: <http://www.emissieregistratie.nl/ERPUBLIEK/documenten/Water/Factsheets/English/Fireworks.pdf> (12/01-2022).

Nielsen et al., 2012: Nielsen, O.-K., Plejdrup, M.S., Winther, M., Gyldenkærne, S., Thomsen, M., Fauser, P., Nielsen, M. Mikkelsen, M.H., Albrektsen, R., Hjelgaard, K., Hoffmann, L. & Bruun, H.G. 2012. Quality manual for the Danish greenhouse gas inventory. Version 2. Aarhus University, DCE – Danish Centre for Environment and Energy, 44 pp. Scientific Report from DCE – Danish Centre for Environment and Energy No. 47. Available at: <http://www.dmu.dk/Pub/SR47.pdf> (12/01-2022).

Nielsen et al., 2021: Nielsen, O.-K., Plejdrup, M.S., Winther, M., Mikkelsen, M.H., Nielsen, M., Gyldenkærne, S., Fauser, P., Albrektsen, R., Hjelgaard, K.H., Bruun, H.G. & Thomsen, M. 2021. Annual Danish Informative Inventory Report to UNECE. Emission inventories from the base year of the protocols to year 2019. Aarhus University, DCE – Danish Centre for Environment and Energy, 580 pp. Scientific Report No. 435. Available at: <http://dce2.au.dk/pub/SR435.pdf> (07/01-2022)

Nordic Sugar, 2021: CO₂-udledningsrapport for 2020 (EU-ETS). Nordic Sugar A/S Nakskov (In Danish). Including earlier versions 2006-2019 Confidential.

Nordic Sugar Nakskov, 2012: Miljøberetning 2010-2012 for Nordic Sugar Nakskov (In Danish). Including earlier versions 1996/97 - 2009/10.

Nordic Sugar Nykøbing, 2010: Grønt regnskab 2009/10 for Nordic Sugar Nykøbing (In Danish). Including earlier versions 1996/97 - 2008/09.

Poulsen, 2001: Poulsen, T.S., Indsamling og genanvendelse af SF₆ fra elsekto- ren. Miljøprojekt nr. 592 2001. Miljøstyrelsen (In Danish). Available at: <http://www2.mst.dk/Udgiv/publikationer/2001/87-7944-417-2/pdf/87-7944-418-0.pdf> (12/01-2022).

Poulsen, T.S. 2022: Danish consumption and emission of F-gases, Year 2020. Miljøstyrelsen - The Danish Environmental Protection Agency. Available at: <https://www2.mst.dk/Udgiv/publications/2022/01/978-87-7038-379-0.pdf> (14-02-2022).

Report Seest, 2005: Rapport vedrørende fyrværkeriulykken i Seest den 3. november 2004, Udarbejdet af en uafhængig ekspertgruppe nedsat den 26. august 2005 af Økonomi- og Erhvervsministeren og Forsvarsministeren. Denmark (In Danish). Available at: <https://www.sik.dk/sites/default/files/2018-10/Rapport%20vedr%C3%B8rende%20fyrv%C3%A6rkeriulykken%20i%20Seest%20den%203.%20november%202004.pdf> (13/01-2022).

Rockwool, 2014a: Miljøredegørelse 2013 for fabrikkerne i Hedehusene, Vamdrup og Øster Doense (environmental reports). Including earlier versions 1996-2012. (In Danish).

Rockwool 2014b: CO₂-overvågningsplan for Rockwool A/S, Vamdrup og Doense CVR: 42391719. Driftsleders godkendte overvågningsplan gældende fra 25/3-2014 (In Danish).

Rockwool, 2021: CO₂-udledningsrapport for 2020 (EU-ETS). Rockwool A/S Doense og Vamdrup (In Danish). Including earlier versions 2006-2019. Confidential.

Saint-Gobain Isover, 2012: CO₂-overvågningsplan for Saint-Gobain Isover A/S, CVR nr: 11933238. Driftsleders godkendte overvågningsplan gældende fra 13/12-2012 (In Danish).

Saint-Gobain Isover, 2015: Grønt regnskab for 2014, Saint-Gobain Isover A/S (In Danish). Including earlier versions 1996-2013.

Saint-Gobain Isover, 2021: CO₂-udledningsrapport for 2020 (EU-ETS). Saint-Gobain Isover A/S (In Danish). Including earlier versions 2006-2019. Confidential.

Shires et al., 2004: Theresa M. Shires and Christopher J. Loughran. American Petroleum Institute (API), Compendium of Greenhouse Gas Emissions Methodologies for the Oil and Gas Industry, February 2004. Available at: https://www.wrapair.org/ClimateChange/GHGProtocol/docs/2004-02_API_COMPENDIUM_of_GHG_Emission_Methodologies_from_O&G.pdf (13/01-2022).

SPIN on the Internet. Substances in Preparations in Nordic Countries.

Statistics Denmark, 2021: Statbank Denmark, in both Danish and English. Available at: www.statbank.dk (06/01-2022).

Stålvalseværket, 2002: Grønt regnskab og miljøredegørelse 2001. Det Danske Stålvalseværk A/S (In Danish). Including earlier years 1996-2000.

US EPA, 2004: Technology Transfer Network Clearinghouse for Inventories & Emissions Factors. AP 42, Fifth Edition, Volume I, Chapter 11: Mineral Products Industry Available at: <https://www3.epa.gov/ttnchie1/ap42/ch11/> (11/01-2022).

Aalborg Portland, 2005: Henrik Møller Thomsen, Personal communication 2005.

Aalborg Portland, 2008: Henrik Møller Thomsen, Personal communication 17 September 2008.

Aalborg Portland, 2013a: Torben Ahlmann-Laursen, Personal communication 19 November 2013.

Aalborg Portland, 2013b: CO₂-overvågningsplan for Aalborg Portland A/S, CVR nr: 14244441, signeret af Torben Ahlmann-Laursen den 15/03-2013 (In Danish).

Aalborg Portland, 2020: Miljøredegørelse 2019, Grønt regnskab og arbejdsmiljø (Environmental report). And earlier versions 1998-2018. (In Danish).

Aalborg Portland, 2021a: CO₂-udledningsrapport for 2020 (EU-ETS). Aalborg Portland A/S. Including earlier versions 2006-2019. Confidential.

Aalborg Portland, 2021b: Thomas Gert Kristensen, Personal communication 28 September 2021.

5 Agriculture

The data presented in Chapter 5 relate to Denmark only, whereas information for Greenland is included in Chapter 16 and for the Faroe Islands in Annex 8.

The emission of greenhouse gases from agricultural activities includes:

- CH₄ emissions from enteric fermentation, manure management and field burning
- N₂O emissions from manure management, agricultural soils and field burning
- CO₂ emissions from liming, urea use and use of other carbon-containing fertilisers

For emissions of air pollutants covered by the NEC Directive or the UNECE LRTAP Convention, see the Danish Informative Inventory Report (Nielsen et al., 2021).

Emissions from rice production and burning of savannahs do not occur in Denmark and consequently these categories have been reported as Not Occurring.

5.1 Overview of sector

In CO₂ equivalents, the agricultural sector contributes with 27 % of the Danish greenhouse gas emissions (GHG) in 2020 excl. LULUCF. Next to the energy sector, the agricultural sector is the largest source of GHG emission in Denmark. The majority of agricultural greenhouse gas emissions are covered by N₂O and CH₄, which contributes in 2020 with 89 % and 80 % respectively of the total Danish emissions of N₂O and CH₄.

From 1990 to 2020, the emissions decreased from 13.3 million tonnes CO₂ equivalent to 11.3 million tonnes CO₂ equivalent, which corresponds to a 16 % reduction (Table 5.1). CH₄ is the largest contributor to the overall agricultural greenhouse gas emission, accounting for 52 % in CO₂ equivalents in 2020. The decrease in the total agricultural emission is mainly caused by a decrease in N₂O emission, while the CH₄ emission is nearly unaltered.

Table 5.1 Emission of GHG in the agricultural sector in Denmark 1990 – 2020.

	1990	1995	2000	2005	2010	2015	2018	2019	2020
CH ₄ , kt CO ₂ eqv.	5 897	6 116	6 012	6 010	5 972	5 900	5 986	5 847	5 881
N ₂ O, kt CO ₂ eqv.	6 827	6 070	5 591	5 212	4 941	5 016	4 925	5 150	5 132
CO ₂ , kt CO ₂ eqv.	613	534	268	222	156	176	244	185	254
Total, kt CO ₂ eqv.	13 338	12 719	11 871	11 443	11 069	11 092	11 154	11 183	11 268

The major part of the emission is related to livestock production, which in Denmark is dominated by the production of cattle and swine.

Figure 5.1a-b shows the distribution of N₂O and CH₄ emissions across the main agricultural sources. The total N₂O emission from 1990-2020 has decreased by 25 % and can largely be attributed to the decrease in N₂O emissions from agricultural soils. This reduction is due to a proactive national environmental policy over the last thirty years to prevent loss of nitrogen from agricultural soil to the aquatic environment. The emission from agricultural soil

is based on emission from a range of sources, where emission from inorganic fertiliser, animal manure applied to soil and organic soils are the most important emission sources. The main reason for the decrease is a strong decrease in use of inorganic fertiliser. In 2016, 2017, 2019 and 2020 is seen an increase in use of inorganic fertiliser which increases the emission of N₂O from agricultural soils. In 2018, the emission decreases due to decrease in emission from inorganic fertiliser mainly due exceptional weather conditions this year. The higher amount of used N in inorganic fertiliser in 2016, 2017, 2019 and 2020 is caused by a political agreement on Food and Agricultural package, adopted in December 2015 (MEFD, 2017). The purpose of the agreement was to establish better framework conditions for the agricultural production, to ensure opportunities for economic growth and increased exports and increased employment in interaction with nature and the environment. This agreement made it legally possible to use more nitrogen for some areas.

The CH₄ emissions from 1990 to 2020 shown in Figure 5.1b indicate a decrease in emission from enteric fermentation, which is mainly due to a decrease in the number of cattle. A contrasting development has taken place in emission from manure management. Structural changes in the sector have led to a move towards the use of slurry-based housing systems, which have a higher emission factor than systems with solid manure. The decrease and the increase almost balance each other out and the total CH₄ emission from 1990 to 2020 has increased less than 1 %.

CO₂ emissions from liming and inorganic N-fertiliser has decreased by 59 % from 1990 to 2020, mainly due to decrease in emission from liming. The decrease in use of lime is due to change in fertiliser practice where the use of inorganic N-fertiliser has decreased and use of N from manure has increased (Knudsen, 2004).

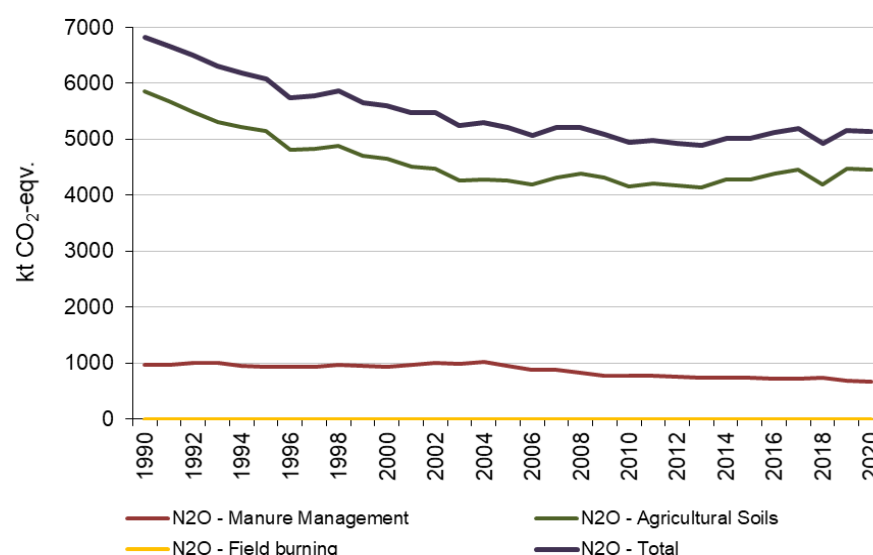

Figure 5.1a Danish agricultural N₂O emissions 1990 – 2020.

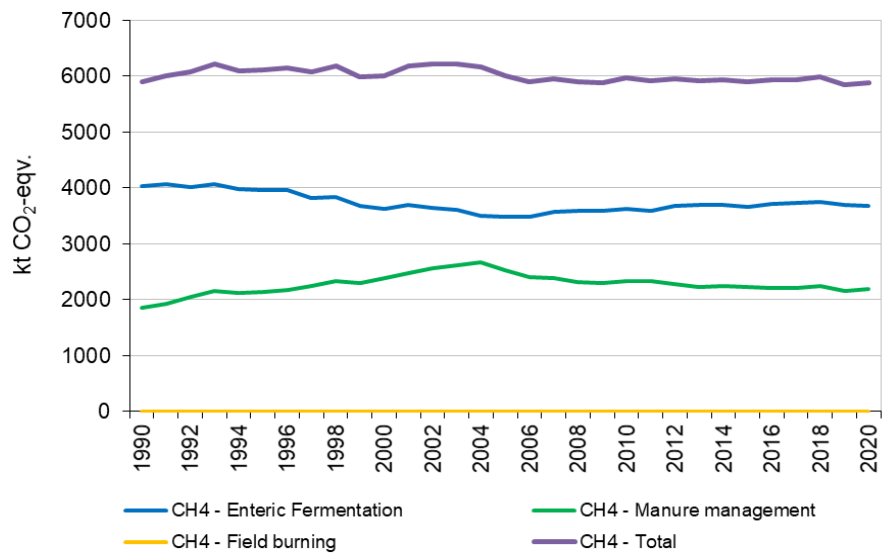

Figure 5.1b Danish agricultural CH₄ emissions 1990 – 2020.

5.1.1 Methodology overview, tier

Table 5.2 shows the methodology and emission factor used at subcategory level.

Table 5.2 Overview for methodology and emission factor used.

CRF code	Category	Substance	Tier ¹⁾	EF ²⁾
3A	Enteric fermentation:			
3A1a	Dairy cattle	CH ₄	Tier2	CS
3A1b	Non-dairy cattle	CH ₄	Tier2	D
3A2	Sheep	CH ₄	Tier2	D
3A3	Swine	CH ₄	Tier2	D
3A4	Other livestock - deer	CH ₄	Tier2	D
	Other livestock – goats	CH ₄	Tier2	D
	Other livestock - horses	CH ₄	Tier2	D
	Other livestock - poultry	CH ₄	Tier1	OTH
	Other livestock – other ³⁾	CH ₄	Tier1	OTH
3B	Manure management:			
3B1a	Dairy cattle	CH ₄	Tier2/CS	CS
3B1b	Non-dairy cattle	CH ₄	Tier2/CS	CS
3B2	Sheep	CH ₄	Tier2/CS	D
3B3	Swine	CH ₄	Tier2/CS	CS
3B4	Other livestock - deer	CH ₄	Tier2/CS	D
	Other livestock – goats	CH ₄	Tier2/CS	D
	Other livestock - horses	CH ₄	Tier2/CS	D
	Other livestock - poultry	CH ₄	Tier2/CS	D
	Other livestock – other ³⁾	CH ₄	Tier2/CS	D
3B	Manure management:			
3B1a	Dairy cattle	N ₂ O	Tier2	D
3B1b	Non-dairy cattle	N ₂ O	Tier2	D
3B2	Sheep	N ₂ O	Tier2	D
3B3	Swine	N ₂ O	Tier2	D
3B4	Other livestock - deer	N ₂ O	Tier2	D
	Other livestock – goats	N ₂ O	Tier2	D
	Other livestock - horses	N ₂ O	Tier2	D
	Other livestock - poultry	N ₂ O	Tier2	D
	Other livestock – other ³⁾	N ₂ O	Tier2	D
3B5	Indirect N ₂ O emission	N ₂ O	Tier2	D
3D	Agricultural soil:			
3Da1	Inorganic N fertilisers	N ₂ O	Tier1/CS	D
3Da2a	Animal manure applied to soils	N ₂ O	Tier2	D
3Da2b	Sewage sludge applied to soils	N ₂ O	Tier1/CS	D
3Da2c	Other organic fertiliser applied to soils	N ₂ O	Tier1/CS	D
3Da3	Urine and dung deposited by grazing animals	N ₂ O	Tier2	D
3Da4	Crop residue	N ₂ O	Tier1/CS	D
3Da5	Mineralization	N ₂ O	Tier2	D
3Da6	Cultivation of organic soils	N ₂ O	Tier1	D
3Db1	Atmospheric deposition	N ₂ O	Tier2	D
3Db2	Nitrogen leaching and run-off	N ₂ O	Tier2	D
3F	Field burning of agricultural residues	CH ₄	Tier1	D
3F	Field burning of agricultural residues	N ₂ O	Tier1	D
3G	Liming	CO ₂	Tier1	D
3H	Urea application	CO ₂	Tier1	D
3I	Other carbon-containing fertilisers	CO ₂	Tier1	D

¹⁾Tier 1 and T2: IPCC (2006) default, CS: Country specific.

²⁾D: IPCC (2006) default. CS: Country specific. OTH: Other.

³⁾Ostrich, pheasants, fur bearing animals.

5.1.2 Key category identification

The key category analysis (KCA) divides the agricultural emissions into 19 subcategories. Table 5.3 lists the KCs covering Approach 1 and Approach 2. Approach 1 only gives key category identification based on the quantitative emission, while Approach 2 also includes the uncertainties (refer to Chapter 1.5). In 1990, 12 of the 19 agricultural sources were identified as key categories and 13 sources were key categories if uncertainties were taken into account (Approach 2). In 2020, seven of the sources are listed as key categories according to level and trend for Approach 1 and 12 sources in Approach 2. For the methodological choice, Denmark uses the key categories identified using both Approach 1 and Approach 2 for the latest year as well as key categories identified for the trend from 1990 to the latest year.

The two key categories with the highest emissions are CH₄ from enteric fermentation and CH₄ emissions from manure management. Regarding the enteric fermentation, the cattle production is the main contributor, while the swine production is the most important category for manure management.

Table 5.3 Key category identification Tier 1 and Tier 2 from the agricultural sector 1990 and 2020.

CRF table	Compounds	Emission source	Key category identification	
			Approach 1	Approach 2
2020				
3.A	CH ₄	Enteric fermentation	Level/trend	Level/trend
3.B	CH ₄	Manure management	Level/trend	Level/trend
3.F	CH ₄	Field burning of agri. residues	-	-
3.B	N ₂ O	Manure management	Level	Level/trend
3.B.5	N ₂ O	Atmospheric deposition	Level	Level
3.Da.1	N ₂ O	Inorganic N fertilisers	Level/trend	Level/trend
3.Da.2a	N ₂ O	Animal manure applied to soils	Level/trend	Level/trend
3.Da.2b	N ₂ O	Sewage sludge applied to soils	-	-
3.Da.2c	N ₂ O	Other organic fertiliser applied to soils	-	Level/trend
3.Da.3	N ₂ O	Urine and dung deposited by grazing animals	Level	Level
3.Da.4	N ₂ O	Crop residue	Level/trend	Level/trend
3.Da.5	N ₂ O	Mineralization		Level/trend
3.Da.6	N ₂ O	Cultivation of organic soils	Level/trend	Level/trend
3.Db.1	N ₂ O	Atmospheric deposition	Level	Level/trend
3.Db.2	N ₂ O	Nitrogen leaching and run-off	Level	Level/trend
3.F	N ₂ O	Field burning of agri. residues	-	-
3.G	CO ₂	Liming	Level	Level/trend
3.H	CO ₂	Urea application	-	-
3.I	CO ₂	Other carbon-containing fertilisers	-	-
1990				
3.A	CH ₄	Enteric fermentation	Level	Level
3.B	CH ₄	Manure management	Level	Level
3.F	CH ₄	Field burning of agri. residues	-	-
3.B	N ₂ O	Manure management	Level	Level
3.B.5	N ₂ O	Atmospheric deposition	Level	Level
3.Da.1	N ₂ O	Inorganic N fertilisers	Level	Level
3.Da.2a	N ₂ O	Animal manure applied to soils	Level	Level
3.Da.2b	N ₂ O	Sewage sludge applied to soils	-	-
3.Da.2c	N ₂ O	Other organic fertiliser applied to soils	-	-
3.Da.3	N ₂ O	Urine and dung deposited by grazing animals	Level	Level
3.Da.4	N ₂ O	Crop residue	Level	Level
3.Da.5	N ₂ O	Mineralization	Level	Level
3.Da.6	N ₂ O	Cultivation of organic soils	Level	Level
3.Db.1	N ₂ O	Atmospheric deposition	-	Level
3.Db.2	N ₂ O	Nitrogen leaching and run-off	Level	Level
3.F	N ₂ O	Field burning of agri. residues	-	-
3.G	CO ₂	Liming	Level	Level
3.H	CO ₂	Urea application	-	-
3.I	CO ₂	Other carbon-containing fertilisers	-	-

5.2 Data sources

The calculated emissions are based on methods described in the IPCC Guidelines for National Greenhouse Gas Inventories (IPCC, 2006).

Activity data and emission factors are collected and discussed in cooperation with specialists and researchers in various institutes with agricultural expertise, such as the DCA - Danish Centre for Food and Agriculture – Aarhus University, Statistics Denmark, SEGES, the Danish Agricultural Agency, the Danish Environmental Protection Agency and the Danish Energy Agency. In this way, both data and methods will be evaluated continually, according to the latest knowledge and information. DCE - Danish Centre for Environment and Energy, Aarhus University has established data agreements with the institutes and organisations to assure that the necessary data are available to prepare the emission inventory on time.

Table 5.4 List of institutes involved in the emission inventory for the agricultural sector.

References	Link	Abbreviation	Data/information
Statistics Denmark – Agricultural Statistics	www.dst.dk	DSt	- livestock production - milk yield - slaughtering data - export of live animal - poultry - land use - crop production - crop yield
Danish Centre for Food and Ag- riculture, Aarhus University	www.dca.au.dk	DCA	- N-excretion - feeding situation - animal growth - use of straw for bedding - N-content in crops - modelling of data regarding N-leaching/runoff - NH ₃ emissions factor
SEGES	www.seges.dk	SEGES	- housing type (until 2004) - grazing situation - manure application time and methods - estimation of extent of field burning of agricultural residue - acidification of slurry
Danish Environmental Protec- tion Agency	www.mst.dk	EPA	- sewage sludge used as fertiliser (until 2004) - industrial waste used as fertiliser
The Danish Agricultural Agency	www.lbst.dk	DAA	- inorganic N fertiliser (consumption and type) - housing type (from 2005) - sewage sludge used as fertiliser (from 2005 based on the register for fertilization) - number of animals from the Central Husbandry Register
The Danish Energy Agency	www.ens.dk	DEA	- manure delivered to biogas plants

The emissions from the agricultural sector are calculated in a comprehensive agricultural model complex called IDA (Integrated Database model for Agricultural emissions). The model complex is designed in a relational database system (MS Access). Input data are stored in tables in one database called IDA_Backend and the calculations are carried out as queries in another linked database called IDA. This model complex, as shown in Figure 5.2, is implemented in great detail and is used to cover emissions of air pollutants and greenhouse gases. Thus, there is a direct link between the NH₃ emission and the emission of N₂O.

IDA - Integrated Database model for Agricultural emissions

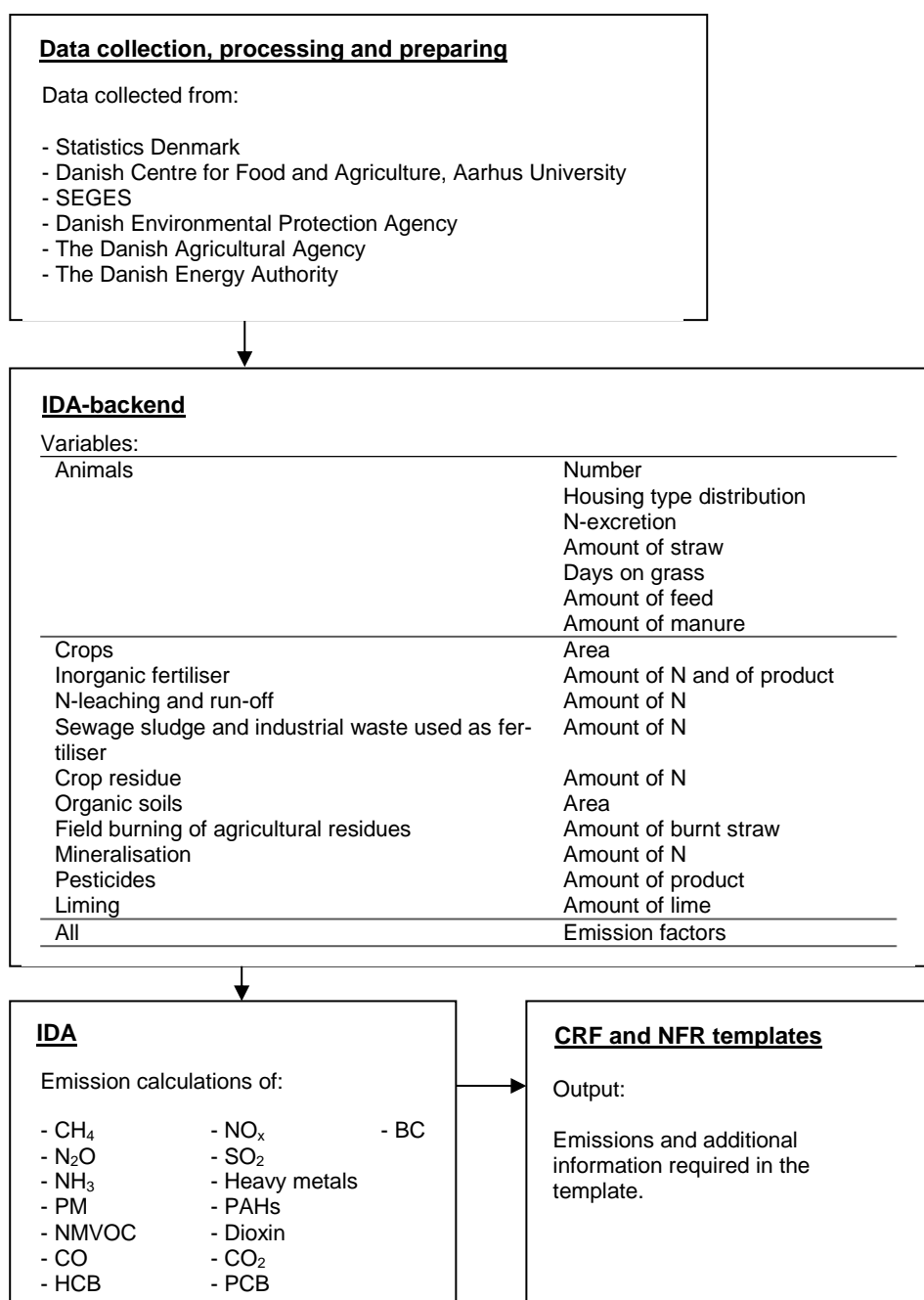

Figure 5.2 IDA - Integrated Database model for Agricultural emissions.

Most emissions relate to livestock production, which is based on information on the number of animals, the distribution of animals according to housing type and, finally, information on feed consumption and excretion.

IDA operates with 42 different livestock categories, according to livestock type, weight class and age. These categories are subdivided into housing type and manure type, which results in 289 different combinations of livestock sub-categories and housing types (see Annex 3D Table 3D-1). For each of these combinations, information on e.g. feed intake, digestibility, excretion and grazing days is included. The emission is calculated from each of these sub-categories and then aggregated in accordance with the IPCC livestock categories given in the CRF.

Table 5.5 Livestock categories and subcategories.

CRF	Aggregated livestock categories as given in IPCC	Includes	No. of subcategories in IDA, animal type/housing system
3B 1a	Dairy Cattle ¹	Dairy Cattle	40
3B 1b	Non-dairy Cattle ¹	Calves (<½ yr), heifers, bulls, suckling cattle	129
3B 2	Sheep	Sheep and lambs	2
3B 3	Swine	Sows, weaners, fattening pigs	52
3B 4	Deer		1
	Goats	Including kids (meet, dairy and mohair)	3
	Horses	<300 kg, 300 - 500 kg, 500 - 700 kg, >700 kg	4
	Poultry	Hens, pullets, broilers, turkeys, geese, ducks	43
	Fur-bearing animals	Mink and foxes	8
	Ostriches	Mother ostriches, chickens	4
	Pheasants	Hens, chickens	2

¹⁾ For all subcategories, large breed and jersey cattle are distinguished from each other.

It is important to point out that changes over the years, both to the national emission and the implied emission factor, are not only a result of changes in the numbers of animals, but also depend on changes in the allocation of sub-categories, changes in feed consumption and changes in housing type.

5.2.1 Number of animals

Livestock production is primarily based on the agricultural census from Statistics Denmark (DSt). For many animal categories, the number given in the annual Agricultural Statistics can be used directly. However, for weaners, fattening pigs, bulls and poultry the number is based on slaughter data also collected from the Agricultural Statistics. This is because the production cycle for these animals is under one year and the normative figures are based on produced animals.

Only farms larger than five hectares are included in the annual census from Statistics Denmark. Especially horses, goats and sheep are placed on small farms, which mean that the number of animals given in the Agricultural Statistics is not representative (underestimates the actual animal population). Therefore, the number of sheep and goats is based on the Central Husbandry Register (CHR), which is the central register of farms and animals managed by the Ministry of Environment and Food of Denmark. From 2010, the annual census includes farms with more than 20 goats and sheep, but the CHR is considered as more reliable because the register include all animals regardless of farm size. The number of horses is based on data from SEGES (Kold, 2019 and Clausen, 2020).

The number of deer and ostriches is also based on CHR because these are not included in the Agricultural Statistics published by Statistics Denmark. The number of pheasants is based on expert judgement from Department of Eco-science, Aarhus University and the Danish pheasant breeding association (Stenkjær, 2010, pers. comm.).

The agricultural annual census in present form goes back to 1977 (DSt, 2010). The survey has taken place every year as a questionnaire based survey, where the farmer has received a questionnaire in a letter with an obligation to complete it. The questionnaire has varied from year to year depending on EU requirements and national needs. From 1977 to 1983, the survey was based on total censuses where all farms were included, which also is the case for the

years; 1985, 1987, 1989, 1999 and 2010. The remaining surveys is based on sample surveys; 1984, 1986, 1988, 1990-98, 2000-09 and 2011-20 and include around 20-35 % of all farms and around 50 % of the farms in 2003, 2005 and 2007.

As soon as the data from the questionnaires are processed, tested and quality assured, the data are published annually at Statistics Denmark's homepage; <http://www.statistikbanken.dk> and are available in both English and Danish.

Annex 3D Table 3D-2 provides number of animals allocated on all livestock subcategories.

5.2.2 Housing type

From 2005, all farmers have to report to the Danish Agricultural Agency (DAA) information concerning the housing type. Annex 3D Table 3D-1 shows the housing types for each livestock category for the years 1990 - 2020.

Before 2005, there exists no official statistics, which cover the distribution of animals according to housing type. Therefore, the distribution is based on an expert judgement from SEGES and DCA (Rasmussen, 2006, Lundgaard 2006). Approximately 90-95 % of Danish farmers are members of SEGES, which regularly collects statistical data from the farmers on different issues, as well as making recommendations with regard to farm buildings. Hence, SEGES has a good understanding of which housing types that are currently in use and also the changes over time.

5.2.3 NH₃ reducing technology

NH₃ reducing technology in housings and storage has been taken in to account in the emission calculations. The technologies included are acidification in housings with cattle and swine, cooling of swine manure in housings, frequent removal of manure in fur animal housings, heat exchangers in housing of broilers and solid cover of manure tanks.

Reducing of NH₃ emission in housing and storage increase the amount of N in storage and for application, which increase the emission of N₂O from agricultural soils.

No possible reduction in CH₄ emissions, because of NH₃ reducing technology, is taken in to account.

5.2.4 Feed consumption and manure excretion

The DCA provide Danish standards related to feed consumption, excreted volumes, nutrient content of nitrogen, phosphor and potassium, dry matter in manure and contribution of different manure type. These standards are all a part of the "Danish Normative System", which is used for fertiliser planning and control by the Danish farmers and authorities (Poulsen et al., 2001, Børsting et al., 2021). The complexity and dynamics of the system has increased during the years to secure the development of accurate values. Furthermore, the normative system includes emission factors for NH₃, which is based on a combination of measurements and model calculations. Emission factors for NH₃ from the housing unit and storage are given in Annex 3D Table 3D-3 (a-d) and 3D-4.

The Danish normative standards are based on practical farming and thus reflect the actual Danish agricultural production conditions. DCA receive data from SEGES, which is the central office for all Danish agricultural advisory services. SEGES carries out a considerable amount of research itself, as well as collecting efficacy reports from the Danish farmers for dairy production, meat production, pig production, etc., to optimise productivity in Danish agriculture. Feeding plans are used to provide values to the Danish Normative System and for dairy cows; the values are based on approximately 800 feeding plans. In total the normative standards covers feed plans from 15-18 % of the Danish dairy production, 25-30 % of the pig production, 80-90 % of the poultry production and approximately 100 % of the fur production. A high fraction of the pig production is represented, which is caused by the intensive focus on the possibilities to optimize the feed intake to increase the feed efficiency. The values covering the cattle production can be considered as reliable, even though only 15-18 % of the productions are represented. These values include mainly feeding plans from the farmers with a production efficiency corresponding to a middle level. The farmers with a high productivity level are often not users of SEGES, which also is the case for farmers with a low productivity level.

Previously, the normative standards were updated and published every third or fourth year (Laursen, 1987; Laursen, 1994; Poulsen and Kristensen, 1997). From 2001, these standards are updated annually and available to download at the homepage of DCA:

<http://anis.au.dk/forskning/sektioner/husdyrernaering-og-fysiologi/normtal/> (Jan. 2022).

One of the reports concerning the normative data is published in English in Poulsen and Kristensen (1998) and is available at the homepage of DCA, see list of references. The normative data are updated every year.

5.3 Enteric fermentation

5.3.1 Description

The major part of the agricultural CH₄ emission originates from digestive processes. In 2020, this source accounts for 33 % of the total GHG emission from agriculture. The emission is primarily related to ruminants and, in Denmark, particularly to cattle, which, in 2020, contributed with 87 % of the emission from enteric fermentation. The emission from swine production is the second largest source and covers 9 % of the emission from enteric fermentation, followed by horses (3 %) and sheep, goats, deer and poultry (1 %).

From 1990 to 2020, the emission from enteric fermentation has overall decreased by 9 %, which is primarily related to a decrease in the number of cattle, combined with increase in milk yield and gross energy (GE) for dairy cattle. The number of swine has increased from 9.5 million in 1990 to 13.2 million in 2020, but this increase is only of minor importance in relation to the total CH₄ emission from enteric fermentation. The emission where lowest in 2005 but have increased slightly until 2020, mainly due to a slightly increase in emission from cattle.

5.3.2 Methodological issues

The methodology for estimating emissions from enteric fermentation is based on IPCC Guidelines for National Greenhouse Gas Inventories (IPCC, 2006).

The methodology for poultry, ostrich and pheasants is based on Tier 1, while the remaining animal categories are based on a Tier 2/Country Specific (CS) approach. CH₄ emission from enteric fermentation from fur farming is considered to be non-applicable based on country-specific information (Hansen, 2010, pers. comm.) and therefore the notation key NA are used for fur-bearing animals in CRF for enteric fermentation. Feed consumption for all animal categories is based on the Danish normative figures. Default values for the methane conversion rate (Y_m) given by the IPCC are used for all livestock categories, except for dairy cattle, where a national Y_m is used for all years.

Tier 1

Emission factors used for poultry, ostrich and pheasants are based on the emission factors given by Wang & Huang (2005). EF for broilers with a life cycle of 30-56 days is scaled in proportion to 42 days for broilers given by Wang & Huang (2005). Organic broilers with a life cycle of 81 days are scaled in proportion to the Taiwan country chicken with 91 days of life cycle and pullets with a life cycle of 112-119 days are scaled in proportion to the 140 days given for pullets by Wang & Huang (2005). EF for ducks, geese, turkeys, ostrich chickens and pheasant chickens is scaled by weight in proportion to a Danish broiler with 40 days of life cycle. For laying hens, the EF given by Wang & Huang (2005) is used and for ostrich hens and pheasant hens, the EF is scaled by weight in proportion to a laying hen. All EFs for CH₄ from enteric fermentation for poultry are shown in Annex 3D Table 3D-5.

Tier 2

The Tier 2/CS equation for EF of enteric fermentation is the sum of the feeding situation in winter and summer. The EF is based on actual feeding plans, which is provided from data for feed units (FU) in the feed for each livestock category. Except from dairy cattle, where the EF is based on kg dry matter (DM) in the feed. For dairy cattle, feeding with sugar beets is taken into account, because sugar beet feeding gives a higher methane production rate compared to grass and maize due to the high content of easily convertible sugar. However, it is only dairy cattle, which have sugar beets in the feed. The parts of the equation concerning sugar beet will be left out for the remaining animal categories.

$$EF = EF_{winter} + EF_{summer}$$

Dairy cattle:

$$EF_{winter,dairy\ cattle} = F \cdot$$

$$\left((GE_{F\ winter}/55.65) \cdot Y_{m\ excl\ beet} \cdot (1 - grazing\ days/365 - days\ with\ beet/365) \right. \\ \left. + (GE_{F\ winter}/55.65) \cdot Y_{m\ incl\ beet} \cdot days\ with\ beet/365 \right)$$

$$EF_{summer,dairy\ cattle} = F \cdot \left(\frac{GE_{F\ summer}}{55.65} \right) \cdot Y_{m\ grazing} \cdot \frac{grazing\ days}{365}$$

Where:

- EF_{winter} = Emission factor for winter feed, kg CH₄ per head per year
- EF_{summer} = Emission factor for summer feed, kg CH₄ per head per year
- F = feed, kg DM
- GE_{F,winter} = gross energy per kg DM, MJ per kg DM in winter
- GE_{F,summer} = gross energy per kg DM, MJ per kg DM in summer

Y_m = methane conversion factor, per cent of gross energy in feed converted to methane
 55.56 = energy content of CH₄, MJ per CH₄

Other animals:

$$EF_{winter} = FU \cdot \left(\left(\frac{GE_{FUwinter}}{55.65} \right) \cdot Y_m \cdot \left(1 - \frac{\text{grazing days}}{365} \right) \right)$$

$$EF_{summer} = FU \cdot \left(\frac{GE_{FU summer}}{55.65} \right) \cdot Y_{m \text{ grazing}} \cdot \frac{\text{grazing days}}{365}$$

Where:

EF_{winter} = Emission factor for winter feed, kg CH₄ per head per year
 EF_{summer} = Emission factor for summer feed, kg CH₄ per head per year
 FU = feeding units
 $GE_{FU,winter}$ = gross energy per feeding unit, MJ per FU in winter
 $GE_{FU, summer}$ = gross energy per feeding unit, MJ per FU in summer
 Y_m = methane conversion factor, per cent of gross energy in feed converted to methane
 55.56 = energy content of CH₄, MJ per CH₄

Thus, to calculate the total gross energy (GE) intake, the GE per kg DM or GE per feed unit – defined as GE_F or GE_{FU} , respectively – needs to be estimated. A feed unit in Denmark is defined as the feed value in 1.00 kg barley with a dry matter content of 85 % (DSt, 2010). For other cereals, e.g. wheat and rye one feed unit is 0.97 kg and 1.05 kg, respectively.

Gross energy intake

GE_F for dairy cattle are estimated by DCA (Aaes, 2016, pers. comm.). From 2014 feed intake for dairy cattle given in the normative figures are given in kg DM per year and the energy in the feed is given in MJ per kg DM. The energy intake is a standard winter feed regardless of whether the animal grazes or not. As recommended by previous expert review teams, the feed intake and energy in the feed for the years 1990-2013 is recalculated. Previous the calculation was based on FU for the years 1990-2013, which is now replaced by the calculation based on DM for all years. See Annex 3D Table 3D-10 for time series for GE for dairy cattle.

For all other livestock categories than dairy cattle, the estimation of GE is GE_{FU} . GE_{FU} is based on the composition of feed intake and the energy content in proteins, fats and carbohydrates based on actual efficacy feeding controls or actual feeding plans at farm level, collected by SEGES or DCA. The data are given in Danish feed units or kg feedstuff and these values are converted to mega joule (MJ). The calculation is shown in the equation below:

$$GE_{FU} = \frac{\text{MJ/day}}{\text{FU/day}}$$

$$\text{FU/day} = \frac{\text{kg dm}}{\text{day}} \cdot \frac{\text{FU}}{\text{kg dm}}$$

$$\text{MJ/day} = \frac{\text{kg dm}}{\text{day}} \cdot \frac{\text{MJ}}{\text{kg dm}}$$

$$\text{MJ/kg dm} = \%_{\text{Crudeprotein}} \cdot E_{\text{Crudeprotein}} + \%_{\text{Crudefat}} \cdot E_{\text{Crudefat}} + \%_{\text{Carbohydrates}} \cdot E_{\text{Carbohydrates}}$$

$$\%_{\text{Carbohydrates}} = 100 - (\%_{\text{Crudeprotein}} + \%_{\text{Crudefat}} + \%_{\text{Raw ashes}})$$

Where:

GE_{FU}	= gross energy per feed unit, MJ per FU
FU	= feed unit
MJ	= mega joule
DM	= dry matter
$\%_{\text{crude protein}}$	= share of crude protein in the feed, %
$E_{\text{crude protein}}$	= energy factor for crude protein, 24.24 MJ per kg DM
$\%_{\text{raw fat}}$	= share of crude fat in the feed, %
$E_{\text{raw fat}}$	= energy factor for crude fat, 34.12 MJ per kg DM
$\%_{\text{carbohydrates}}$	= share of carbohydrates in the feed, %
$E_{\text{carbohydrates}}$	= energy factor for carbohydrates, 17.30 MJ per kg DM
$\%_{\text{raw ashes}}$	= share of raw ashes in the feed, %

For horses, heifers, suckling cattle, sheep and goats an average winter feed plan is provided based on information from DCA and SEGES on which the calculation of the GE content is based. Feeding conditions for deer is comparable with goats, why the GE for deer is based on feed plans for goats. In Annex 3D Table 3D-6 and 3D-7 are listed all parameters for winter feeding plans covering the amount of proteins, fats and carbohydrates in the feed, FU per kg, kg dry matter per day and MJ per day. Annex 3D Table 3D-8 and 3D-9 provides additional information about feed intake given in FU and grazing days for each livestock category.

Estimation of $GE_{\text{FU, summer}}$ covers the time where animals are grazing.

Table 5.6 GE per feeding unit, MJ per FU.

	$GE_{\text{FU, winter}}$	$GE_{\text{FU, summer}}$
Calves and bulls	18.3	18.8
Heifers	25.8	18.8
Suckling cattle	34.0	18.8
Sows	17.5	17.5
Weaners	16.5	16.5
Fattening pigs	17.3	17.3
Horses, sheep, goats and deer	30.0	18.8

In Annex 3D, Table 3D-11, the annual average feed intake given in GE as MJ per day is shown, from 1990 to 2020, for each livestock category. As seen in Annex 3D Table 3D-11, GE for heifers increases from 2005 to 2007. In 2007, new estimations and measurements received from DCA shows that the GE for heifers differs from the previous estimates. This development is not caused by a single year change in feed intake but due to changes in feed practice during some years. Therefore, interpolation of GE for heifers was chosen from year 2004 to 2007 to avoid a significant jump from 2006 to 2007. The GE for non-dairy cattle is an average of GE for calves, heifers, bulls and suckling cattle. However, heifers are the most important subcategory and thus affect the weighed GE average for non-dairy cattle, which also increases from 2004 to 2007.

The Tier2/CS for enteric fermentation differs from the IPCC Tier 2 in the calculation of GE. A comparison between these two methods is shown in Chapter 5.13.1.

Methane conversion rate (Y_m)

For dairy cattle, investigations from DCA have shown a change in fodder practice over the years where among others change in fodder practice from use of sugar beet to maize (whole cereal) is seen. Sugar beet feeding gives a higher methane production rate compared to grass and maize due to the high content of easily convertible sugar.

The estimation of the national values of Y_m is for the years 1990-2002 based on the model "Karoline" developed by DCA and based on average feeding plans for 20 % of all dairy cows in Denmark obtained from SEGES (Olesen et al., 2005). DCA have estimated the CH_4 emission for a winter feeding plan for two years, 1991 ($Y_m=6.7$) and 2002 ($Y_m=6.0$). Y_m for the years between 1991 and 2002 are estimated by interpolation. Sugar beets are only included in the winter feeding plan and the Y_m is therefore also adjusted for days on winter and summer feeding plan. It is assumed that winter feeding plan covers 200 days.

New measurements (Hellwing et al. 2016) have developed an updated model for estimating a national Y_m and based on this and fodder practice the Y_m value for dairy cattle are kept at 6.00 from 2002 to 2017 (Lund, pers. comm., 2014). For 2018 and 2020 the model have been run with updated fodder practice and Y_m has been updated (Lund et al 2020, Lund et al 2021) – see Table 5.7. Y_m for 2019 are kept at the same level as for 2018.

For non-dairy cattle and sheep, Y_m given in IPCC (2006) are used. For swine, horses and goats Y_m are based on Crutzen et al. (1986).

Table 5.7 CH_4 conversion rate (Y_m) – national factor used for dairy cattle 1990 – 2020, %.

Dairy cattle	1990	1991	1995	2000	2002-2017	2018-2019	2020
Y_m incl. sugar beet							
Large breed	6.70	6.70	6.45	6.13	6.00	5.94	5.76
Jersey	6.70	6.70	6.45	6.13	6.00	5.92	5.80
Y_m excl. sugar beet							
Large breed	6.00	6.00	6.00	6.00	6.00	5.94	5.76
Jersey	6.00	6.00	6.00	6.00	6.00	5.92	5.80
Y_m grazing	6.00	6.00	6.00	6.00	6.00	6.00	6.00
Average Y_m	6.38	6.38	6.24	6.07	6.00	5.94	5.78

Table 5.8 CH_4 conversion rate (Y_m) for non-dairy cattle, swine, sheep, goats and horses, %.

	Y_m
Bulls and bull calves	3.00
Heifers, heifer calves and suckling cattle	6.50
Swine	0.60
Sheep	6.50
Lamp	4.50
Goats	5.00
Horses	2.50

5.3.3 Emission factor

IEFs vary across the years for dairy cattle, non-dairy cattle, swine, goats, horses and poultry due to changes in feed intake, distribution of animals in subcategories and number of grazing days. For goats, new subcategories are introduced in 2005 and for horses new subcategories are introduced in 2003

and the distribution between subcategories are changed in 2020 and therefore the IEF differs from the other years. For sheep, deer, ostrich and pheasants the IEF is constant. For IEFs for all categories for all years, see Annex 3D, Table 3D-12. The emission from fur farming is considered not applicable (Hansen, 2010, pers. comm.).

The IEF for dairy cattle has increased from 128 kg CH₄ per cow per year in 1990 to 157 kg CH₄ in 2020. The IEF depends on milk yield and feed intake – see Figure 5.3. From 1990 to 2000, the IEF is almost unchanged but increases significant from 2000 to 2020. The development in feed intake follows the same development as the IEF, while the milk yields in percentage increases even more and especially from year 2000. This is caused by an improvements of the feed utilization.

A significant increase of GE is seen from 2013 to 2014, which can be explained by a markedly increase of the average milk yield. In 2011 and 2012 is seen a decrease in the average milk yield, but from 2013 is seen a significant increase of milk yield to a level of approximately 10 950 litre per cow in 2020 (Børsting et al., 2021). This development has to be set in context with the EU milk quota, which no longer existed from 2015. It was possible for the Danish dairy cattle farmers to increase the milk yield from 2010/2011, but the farmers choose to hold back the feeding because of the EU milk quota.

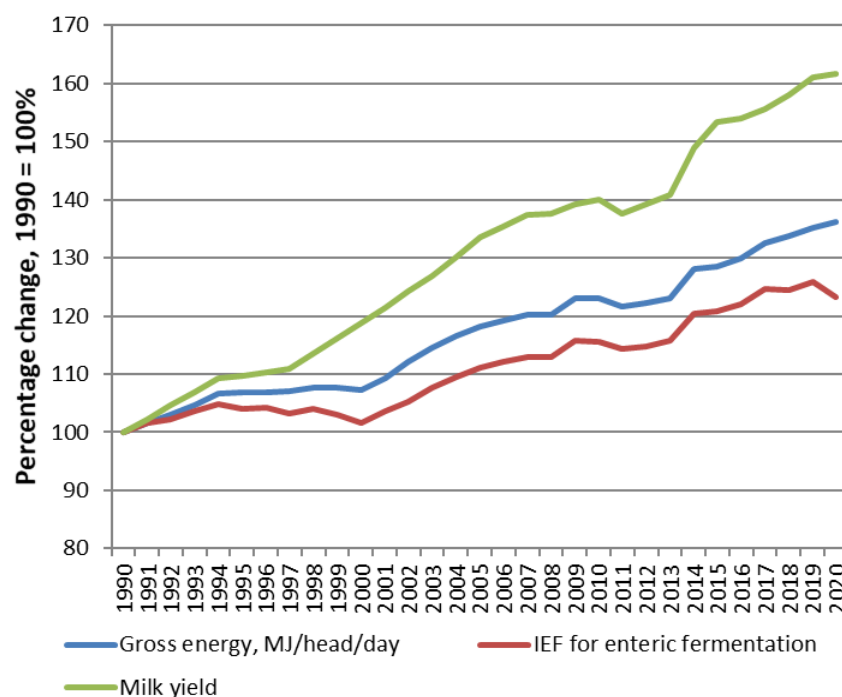

Figure 5.3 Comparison of feed intake, milk yield and IEF for dairy cattle (1990 = 100 %).

A comparison with the IPCC Tier 2 calculation in Chapter 5.13.1 shows that the IEFs using the country specific approach are higher. However, the national IEF reflects the Danish agricultural conditions and the higher level can be explained by high milk production and high feed intake.

The category “Non-Dairy Cattle” includes calves, heifers, bulls and suckling cattle and the IEF is a weighted average of these different subcategories. Changes in allocation of animals between subcategories are reflected in the IEF. The development 1990 - 2008 shows a slight increase due to a higher feed consumption for heifers. From 2008 - 2020 the IEF is stable.

The Danish IEF for non-dairy cattle is lower than the Tier 1 default value given in the 2006 IPCC Guidelines. This is due to a lower weight/lower feed intake (Table 5.9). In Chapter 5.13.1 the national IEF is compared with IPCC Tier 2 calculation and the result shows a good correlation, which indicates the Danish estimate is correct.

Table 5.9 Subcategories for Non-Dairy Cattle 2020 – enteric fermentation.

Non Dairy Cattle – subcategories		Number of animals (DSt)	Energy intake, MJ per day	Methane conversion rate (Y _m), %	IEF, kg CH ₄ per head per yr
Calves, bull (0-6 month)	200 kg	109 892	66.39	3	13.06
Calves, heifer (0-6 month)	150 kg	163 345	50.85	6.5	43.36
Bulls (6 month to slaughter)	large breed: 440 kg sl. weight jersey: 330 kg sl. weight	123 348	104.18	3	20.50
Heifers (6 month to calving)	325 kg	453 559	129.71	6.5	55.30
Suckling cattle	Up to 800 kg	81 583	159.17	6.5	67.86
Average - Non-Dairy Cattle			103.5		40.87
IPCC – default value				6.5	57

The annual variations for swine primarily reflect the changes in the distribution of animals in subcategories (sows, weaners and fattening pigs). The feed intake for sows and weaners has overall increased while the feed intake for fattening pigs has decreased as a result of improved fodder efficiency (Annex 3D Table 3D-8 and 3D-11).

Table 5.10 shows the IEFs for swine subcategories. The Danish IEF for swine is lower than the IPCC default value. The energy intake for fattening pigs is nearly the same as the default value, while the energy intake for weaners is significantly lower. The lower Danish IEF can be explained by the relatively high share of weaners.

Table 5.10 Subcategories for swine 2020 – enteric fermentation.

Swine – subcategories	Number of animals (DSt)	Energy intake, MJ per day	Methane conversion rate (Y _m), %	IEF, kg CH ₄ per head per year
Sows (incl. piglets until 6.7 kg)	1 054 896	71.90	0.60	2.79
Weaners (6.7 – 31 kg)	6 575 943	10.29	0.60	0.40
Fattening pigs (31 – 113 kg)	5 531 788	37.65	0.60	1.48
Average - Swine		21.3		1.05
IPCC – default value			0.60	1.5

It is important to point out that the IEF for goats includes emission from kids due to the Danish normative data. This explains why the Danish IEFs are nearly twice as high as the IPCC default values.

5.3.4 Activity data

Activity data are the number of animals from the agricultural statistics (Statistics Denmark), SEGES and CHR (see Chapter 5.2.1). For numbers see Annex 3D Table 3D-2.

Since 1990, the number of swine and poultry has increased, in contrast to the number of cattle, which has decreased. The number of cattle has decreased because the milk yield has increased while the total production of milk has been fixed by the EU milk quota. Buffalos, camels & llamas and mules & asses are not occurring in Denmark.

5.3.5 Time series consistency

The main part of the emission of CH₄ from enteric fermentation comes from cattle. The development in the milk production has been a high increase in milk per cow, which has increased the feed per cow and thereby increased the implied emission factor. Due to fixing of the total production of milk by the EU milk quota, the number of dairy cattle has decreased. The EU milk quota ended in 2015 and the total milk production has increased, but due to higher feed efficiency, the IEF and emission is almost unaltered. The emission of CH₄ from enteric fermentation from dairy cattle has decreased from 1990 to 2007 and increased from 2008 to 2020.

The emission from non-dairy cattle decreases from 1990 to 2007 and from 2008 to 2020, the emission is almost unaltered.

Emission from swine increases slightly due to increase in number of animals.

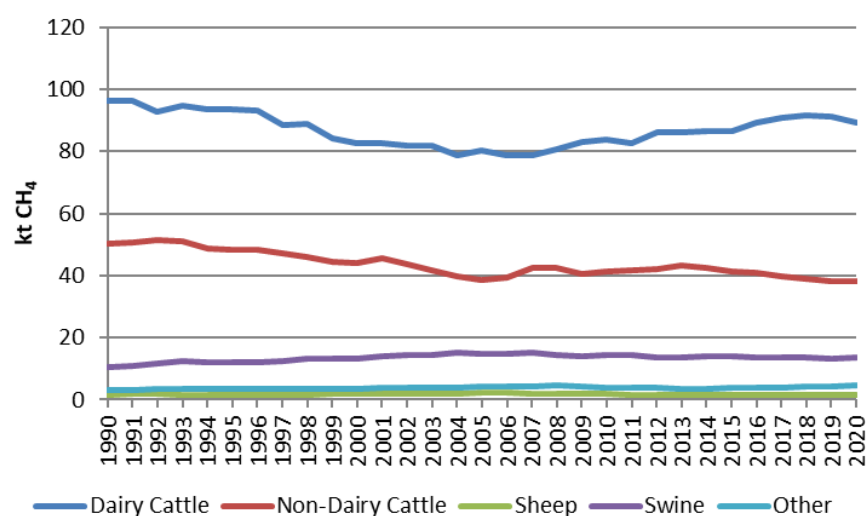

Figure 5.4 Emission of CH₄ from enteric fermentation, 1990-2020. For all numbers see Annex 3D Table 3D-13.

5.4 Manure management - CH₄

5.4.1 Description

This source contributes with 20 % of the total GHG from the agricultural sector in 2020. The major part of the emission originates from the production of swine (51 %) followed by cattle production (41 %). The remaining part is mainly from fur bearing animals (3 %).

5.4.2 Methodological issues

The IPCC Tier 2 methodology is used for the estimation of the CH₄ emission from manure management. The calculation is based on manure excretion instead of feed intake as described in IPCC Guidelines for National Greenhouse Gas Inventories (IPCC, 2006). Default values for maximum methane producing capacity (B₀) given by the IPCC are used (see Table 5.11). For cattle and swine, a national MCF factor are used while for the other animal categories, MCF are based on IPCC (Annex 3D Table 3D-15 and Table 3D-16). The calculation of volatile solids (VS) is based on national data.

Table 5.11 Maximum methane producing capacity (B_0), m^3 CH_4 per kg VS.

	B_0
Dairy cattle	0.24
Non-dairy cattle	0.18
Swine	0.45
Sheep	0.19
Goats	0.18
Deer	0.18
Fur bearing animals	0.25
Horses	0.3
Hens	0.39
Broilers, turkeys, ducks and geese	0.36
Ostrich	0.25

Table 5.12 CH_4 – Manure management – use of national parameters and IPCC default values.

CH_4 – Manure management	Data source
Volatile solids, VS	Based on amount of manure (Annex 3D Table 3D-14)
Maximum methane producing capacity, B_0	IPCC, 2006
Methane conversion factor, MCF	
- Cattle and swine, liquid manure	Based on national measurements (Annex 3D Chapter 3D-1)
- Other	IPCC, 2006

The amount of manure is calculated for each combination of livestock subcategory and housing type and then aggregated to the IPCC livestock categories. In the calculation, grazing days and use of straw in the housing are taken into account. Equation for CH_4 calculation:

$$CH_{4,manure} = EF CH_{4,housing} \cdot n_{animals} + EF CH_{4,grazing} \cdot n_{animals}$$

Where:

$n_{animals}$ = number of animals

$$EF CH_{4,housing} = VS_{housing} \cdot MCF \cdot 0.67 \cdot B_0$$

$$EF CH_{4,grazing} = VS_{grazing} \cdot MCF \cdot 0.67 \cdot B_0$$

Estimation of VS

VS is calculated from data concerning amount of manure, dry matter content, share of VS in dry matter, amount of bedding and grazing days. Except for grazing days for dairy cattle and heifers, all these parameters are based on Danish Normative data. The determination of VS is country-specific, given that it is based on the amount of manure excreted.

$$VS_{housing} = \frac{m}{365} \cdot DM_M \cdot VS_{DM} \cdot (365 - g_1) + s \cdot DM_s \cdot \left(1 - \frac{\% ash}{100}\right) \cdot (365 - g_2)$$

$$VS_{grazing} = \frac{m}{365} \cdot DM_M \cdot VS_{DM} \cdot g_1$$

Where:

VS = volatile solids, kg per animal per year

m = amount of manure excreted, kg per animal per year

DM = dry matter of M manure or S straw, %

VS_{DM} = volatile solids of dry matter, %

g_1 = feeding days on grass, days per year¹
 g_2 = actual days on grass, days per year
 s = amount of straw, kg per animal per year
% ash = ash content in straw

The ash content in straw is set to 4.5 % (SEGES, 2005). VS of dry matter are 80 % for all livestock categories (Sommer et al., 2013). The number of days on grass are based on information from DCA and SEGES (Poulsen et al., 2001, Aaes, 2008, Clausen 2008) and is shown in Annex 3D Table 3D-9. The amount of manure excreted and straw used, depends on housing type and is given in the normative figures table (Børsting et al., 2021).

The VS daily excretion in average for all main livestock categories and cattle subcategories is shown in Annex 3D Table 3D-14.

MCF - Methane conversion factor

A country specific MCF is developed for liquid cattle- and swine manure for both untreated slurry and slurry treated in anaerobic digestion systems. For other animal categories and manure types, default values provided in the IPCC guidelines for MCF are used. For liquid systems for fur bearing animals, the MCF is a weighted value depended on the situation for covered and uncovered slurry tanks in Denmark. Also for swine on deep bedding housing system is used a weighted value due to the residence time of manure in the barn. In Annex 3D, Table 3D-15, is given an overview of all national manure management systems and the MCF related to each system.

Slurry

During national studies in 2015-2016 with the purpose to develop a national MCF for anaerobically digested slurry (Kai et al., 2015 and Petersen et al., 2016), it became apparent that the IPCC 2006 MCF default for untreated cattle- and swine slurry seems to be underestimated. It was therefore decided to estimate a country specific MCF for both the biogas treated and untreated cattle and swine slurry.

The overall methodology for estimating the CH₄ emission from liquid animal manure and anaerobically digested biomass is based on the available amount of volatile substance (VS) in the biomass and the temperature dependent CH₄ formation function; Van't-Hoof/Arrhenius equation (Sommer et al., 2004). The estimation taken into account a 2-pooled concept for estimating the CH₄ emission from degradable VS (VS_d) and from non-degradable VS (VS_{nd}) (Sommer et al., 2004). A more detailed description can be found in Annex 3D Chapter 3D-1. However, the most important data used to calculate the CH₄ emission from untreated and anaerobically digested slurry is listed below:

- VS -The amount of excreted dry matter is taken from the Danish Normative System for animal manure (data included in IDA). The share of VS of dry matter is set as a default to 80 %.
- Temperature
 - inside the barns, based on 20 samples from swine slurry and 11 samples from cattle slurry (Petersen et al., 2016)

¹ Actual days on grass are the number of days that heifers are outside. Feeding days on grass is higher than actual days on grass due to a higher feed intake during grazing compared to the period in housing. Feeding days on grass is a conversion of this higher feed intake on grass. This is only relevant for heifers.

- outdoor storage for untreated liquid manure, based on measurement for Danish and Swedish samples (Husted, 1994) and Rodhe et al. (2009, 2012 and 2015).
- anaerobically digested manure, based on results from Hansen et al. (2006).
- Storage time for slurry in Danish barns, HRT (Hydraulic Retention Time) (Kai et al., 2015)
- The distribution between degradable VS (VSd) and non-degradable VS (VSnd) based on results from Petersen et al. (2016) and Møller & Moset (2015).
- InA (g CH₄ kg⁻¹ VS h⁻¹) is the pre-exponential factor (methane production potential) and Ea (J mol⁻¹) the activation energy of methanogenesis, and both are parameters of a so-called Arrhenius equation for the temperature dependence of methane production. Data for InA and Ea are based on results from Elsgaard et al. (2016) and Petersen et al. (2016).

The trend 1990–2020 for the national estimated MCF for cattle and swine slurry, both digested and not digested, is shown in Table 5.13. The MCF for not digested cattle slurry is changing slightly over time, from 12.00 in 1990 and 12.28 in 2020, while the MCF for not digested swine slurry is reduced from 15.25 in 1990 to 13.31 in 2020. The main reason for changing of MCF over time is caused by change in housing system, which affects the average HRT. The development from housing systems for swine with fully slatted floor towards systems with partly slatted floor, shorter the storage time for slurry and thus reduces the MCF.

The MCF for non digested cattle slurry in 2020 is estimated to 12.28 % and the MCF for digested cattle slurry is 7.74 %, which show a 37 % reduction for biogas treated cattle slurry. The MCF for not digested swine slurry in 2020 is estimated to 13.31 % and the MCF for digested swine slurry to 10.34 %, which corresponds to a 22 % reduction.

Table 5.13 Estimated methane conversion factor (MCF) for digested and not digested cattle and swine slurry from 1990 to 2020, %.

	1990	1995	2000	2005	2010	2015	2018	2019	2020
<u>Cattle</u>									
MCF for digested cattle slurry	6.46	6.43	7.40	7.40	7.66	8.11	7.81	7.78	7.74
MCF for not digested cattle slurry	12.00	11.89	12.70	12.55	12.56	12.59	12.40	12.32	12.28
<u>Swine</u>									
MCF for digested swine slurry	12.13	11.98	11.68	10.92	11.01	10.99	10.33	10.35	10.34
MCF for not digested swine slurry	15.25	15.11	14.87	14.03	13.93	13.67	13.37	13.33	13.31

For liquid systems for fur bearing animals, the MCF is a weighted value depended on the situation for covered and uncovered slurry tanks in Denmark. Due to legislation from 2003, all slurry tanks must be fully covered or have established a floating cover. However, it is difficult to achieve full floating cover all days of the year and some emission can take place during filling and mixing of manure in the tank. Therefore, it is assumed that floating/fixed covers are absent on 2 % in fur production. This results in a weighted MCF of 98% covered slurry (MCF=10 (IPCC, 2006)) and 2 % uncovered (MCF=17 (IPCC, 2006)), which gives a MCF of 10.1 in 2020 for fur slurry.

Deep bedding

The MCF for swine deep bedding depends on how long time the manure is stored in the barn and the emission is particularly higher for bedding store more than one month. The bedding situation is based on information from

SEGES and is different for the three swine subcategories. The lowest MCF at 7.2 % is seen for weaners because 70% of the bedding material is removed during the first month. The situation is opposite for sows where only 20 % of the bedding is removed during the first month, which lead to a higher MCF at 14.7 %.

Table 5.14 MCF factor for swine, deep bedding.

MCF, swine deep bedding	MCF, DK	DK condition, % of year		MCF - IPCC, 2006	
		> 1 month	< 1 month	> 1 month	< 1 month
Deep bedding weaners	7.2 %	30	70	17 %	3 %
Deep bedding fattening	11.4 %	60	40	17 %	3 %
Deep bedding sows	14.7 %	80	20	17 %	3 %

5.4.3 Emission factor

The implied emission factor depends on the VS content in manure, the use of straw, the number of days on grass, MCF and the manure type. The changes of IEFs during the years thus reflect changes in the variables mentioned above. For some livestock categories, which include subcategories, the IEF can also be affected by changes in allocation of animals on the different subcategories. For IEFs for all animal categories for all years, see Annex 3D Table 3D-17.

The IEF for poultry, ostriches, pheasants and deer are almost unaltered from 1990 – 2020 because of very few changes in feed intake and grazing days. A more detailed division in subcategories for goats is implemented from 2007 and for horses in 2003 and the distribution between subcategories are changed for horses in 2020, and explains the small changes in IEFs.

IEF for dairy cattle has increased as a result of increase in feed intake and manure excretion, but also because of changes in housing types (Annex 3D Table 3D-1). Old-style tethering systems with solid manure have been replaced by loose-housing with slurry-based systems, which has a higher MCF. Same pattern is seen for non-dairy cattle, but here the increasing IEF is mainly caused by a higher proportion of bull-calves reared in housings with deep litter, where the MCF is high. The decrease in the IEF for non-dairy cattle from 2012 to 2013 is due to decrease in the use of straw for bulls.

IEF for swine increases from 1990 to 2004 but decreases from 2004 to 2020. This is mainly due to change in housing systems, which affect the calculation of the MCF because of differences in storage time and HRT (Hydraulic Retention Time) in the barns for the different housing types, see Annex 3D Chapter 3D-1.

5.4.4 Activity data

Activity data include both the number of animals and the allocation of animal on different housing types, which determines the manure type. The livestock production is based on the agricultural statistics (Statistics Denmark), SEGES and CHR (see Chapter 5.2.1) and the numbers are given in Annex 3D Table 3D-2. The allocation of housing types is based on registration from the Danish Agricultural Agency (see Chapter 5.2.2 and Annex 3D Table 3D-1).

5.4.5 Biogas treated slurry – activity data

Data regarding the amount of slurry delivered to biogas plants is available for the years 2001, 2003, 2015 - 2020. Data for year 2001 and 2003 is based on a

single investigation provided by the DEA – the Danish Energy Agency, while the data for year 2015 - 2020 is based on data registration covering the main part of all biogas plants, it is called the BIB – register (Biomass Input to Biogas production), managed by DEA. For the intervening years, 1990-1999, 2002 and 2004-2014, the data for amount of slurry delivered to the biogas production is based on an interpolation, by using the relation between the amount of slurry delivered and the total energy production produced at the biogas plants. The total energy production from biogas plants for all years is based on the Energy Statistics (DEA, 2021).

In 2020, manure based biogas plants account for 93 % of the total biogas production, which is produced by approximately 30 large-scale plants and 60 farm-level plants. The BIB register shows that manure accounts for around 54 % of the total biomass input. The remaining biomass input is from sewage sludge, residues from the meat production and biomass from crops. The majority of manure sent to anaerobic digestion is slurry, 90 % (mainly from the cattle- and swine production). Deep litter to biogas treatment accounts for 9 % of the total amount of manure.

In 1990, the energy production produced at the manure based biogas plants is by DEA estimated to 266 TJ, and the amount of slurry used in biogas plant was estimated to 220 kt. In 2020, the energy production is increased to 19 937 TJ (DEA, 2021), and the amount of slurry delivered to the manure based biogas plants is estimated to 8 303 kt slurry. In 2020, around 14 % of the total amount of slurry is delivered to the biogas plants.

The estimation of the national MCF for biogas treated slurry is described in Annex 3D Chapter 3D-1.

5.4.6 Time series consistency

The overall CH₄ emission from manure management is increased by 18 % from 1990 to 2020. The emission from swine has increase from 1990 to 2004 and hereafter decreased until 2020. The emission is mainly determined by the production of fattening pigs and the emission development follows the same trend as the number of produced fattening pigs. Also, change in housing types influence the emission. The emission increases due to change to more slurry based housing systems but decreases again due to change to housing systems with a shorter storage time and HRT (Hydraulic Retention Time) for the manure in the barns.

The emission from dairy cattle is increased from 1990 to 2020, despite a decrease in number of dairy cattle, but is related to higher milk yield and thus higher feed intake and higher manure excretion.

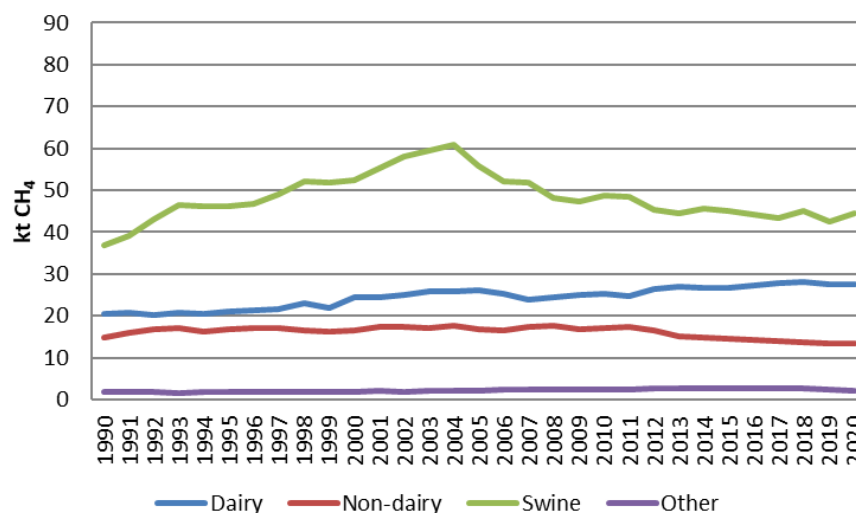

Figure 5.5 CH₄ emission from manure management, 1990 - 2020. For all numbers, see Annex 3D Table 3D-18.

5.5 Manure management - N₂O

5.5.1 Description

The N₂O emission related to CRF category 3B covers a direct and an indirect emission source. The direct emission includes emission from handling of manure in housing and storage and the indirect emission includes the N₂O emission estimated based on the emission of NH₃ and NO_x, which takes place in housing and storage.

The N₂O emission from manure management represents 6 % of the total GHG from the agricultural sector in 2020 and the major part (81 %) originates from the direct emission. Cattle- and swine production account for the largest contribution.

The emission only includes the emission from housing and storage, while the emission from manure deposited on grass is included in CRF category 3D.3 Urine and dung deposited by grazing animals.

5.5.2 Methodological issues

The emission is based on IPCC 2006 Guidelines Tier 2 approach and depends on the N-content in manure. National data is used for N-excretion for all livestock categories.

5.5.3 Emission factor

For the direct emission, a weighted emission factor for cattle and swine slurry with and without natural crust cover is estimated based on the IPCC default N₂O emission factors. For all other manure systems and livestock categories, the IPCC default N₂O emission factors are used. The following table shows the Danish housing system compared to the housing system given in the IPCC 2006 Guidelines Table 10.21 and the respective default emission factors. For cattle slurry, 2 % of the slurry are without crust cover and for swine slurry 5 % are without crust cover.

Table 5.15 Manure management system (MMS) - emission factors.

DK MMS	IPCC MMS	Emission factor, kg N ₂ O-N pr kg Nex
<u>Cattle</u>		
Liquid/Slurry	Liquid/Slurry, with natural crust cover	0.0049
Solid	Solid storage	0.005
Deep bedding	Cattle and Swine deep bedding, no mixing	0.01
Biogas treated slurry	Anaerobic digester	0
<u>Swine</u>		
Liquid/Slurry	Liquid/Slurry, with natural crust cover	0.00475
Solid	Solid storage	0.005
Deep bedding	Cattle and Swine deep bedding, Active mixing	0.07
Biogas treated slurry	Anaerobic digester	0
<u>Poultry</u>		
Housing with or without litter	Poultry manure with or without litter	0.001
<u>Fur-bearing animals</u>		
Slurry	Liquid/Slurry, with natural crust cover	0.005
Solid	Cattle and Swine deep bedding, no mixing	0.01
<u>Sheep and goats</u>		
Deep bedding	Cattle and Swine deep bedding, no mixing	0.01
<u>Horses and ostrich</u>		
Deep bedding	Cattle and Swine deep bedding, no mixing	0.01

N₂O emission factor for indirect emission is based on the IPCC default, i.e. 0.01 kg N₂O-N per kg NH₃-N and NO_x-N volatilized.

5.5.4 Activity data

Besides the number of animals, the activity data for direct emission also includes allocation to housing types and the N-excretion for each animal type.

The livestock production is based on the agricultural statistics (Statistics Denmark), SEGES and CHR (see Chapter 5.2.1) and the numbers are given in Annex 3D Table 3D-2. The allocation to housing types is based on registration from the Danish Agricultural Agency (see Chapter 5.2.2 and Annex 3D Table 3D-1).

The total amount of nitrogen in manure for each animal category is based on the standards given in the "Danish Normative System", which builds on data from the farmers fertilisers plans – see Chapter 5.2.3 for further details. It is important to point out that the nitrogen excretion rates shown in Table 5.16 are values weighted for the subcategories and thus reflects the nitrogen excreted per AAP. The variations in N-excretion during the time series reflect changes in feed intake, feed efficiency and allocation of animals between subcategories. The nitrogen excretion increases for dairy and non-dairy cattle as a result of higher feed intake. It also has to be noted that the average nitrogen excretion for swine has decreased significantly from 1990 to 2010 due to an improvement of feed efficiency; from 2010 to 2020, it is almost unaltered. For poultry, the average nitrogen excretion varies over time due to distribution of animals in subcategories. The trend for the average nitrogen excretion for fur farming follow the trend for feed intake and increases over time. The average nitrogen excretion for horses decreases from 1990 to 1995, but almost unaltered from 1995 to 2020.

Table 5.16 Nitrogen excretion, annual average 1990 – 2020, kg N per head per year (AAP).

CRF Table 3.B(b)	1990	1995	2000	2005	2010	2015	2018	2019	2020
<u>Livestock category</u>									
Dairy cattle	129.49	125.23	125.31	133.30	138.63	143.43	154.67	156.20	156.36
Non-dairy	35.57	35.93	35.70	40.66	42.90	43.09	42.33	42.82	42.45
Sheep	6.64	6.64	6.64	6.64	6.64	6.64	6.64	6.64	6.64
Goats	16.36	16.36	16.36	15.83	16.46	16.85	16.84	16.81	16.81
Swine	11.86	9.74	9.63	9.23	7.85	7.79	7.68	7.55	7.31
Poultry	0.63	0.62	0.55	0.73	0.60	0.56	0.49	0.46	0.48
Horses	44.15	39.56	39.56	39.56	39.56	39.56	39.56	39.56	43.81
Fur farming	4.90	4.65	4.62	5.38	5.82	5.31	5.11	5.47	5.47
Deer	16.00	16.00	16.00	16.00	16.00	16.00	16.00	16.00	16.00
Ostrich	0.00	15.61	15.60	15.60	15.60	15.60	15.60	15.60	15.60
Pheasant	0.04	0.04	0.04	0.04	0.04	0.04	0.04	0.04	0.04
N-excretion, total, kt N per year	292	274	269	277	261	257	264	254	257
N-excretion, housing, kt N per year	258	239	235	251	239	235	243	233	235

Activity data for the indirect emission covers the volatilisation of NH₃ and NO_x, which takes place in housing and during storage of the manure. These are based on national data, for detailed information see Annual Danish Informative Inventory Report (Nielsen et al., 2021). Emission of NH₃ from housing and storage has decreased from 1990 to 2020 mainly due to implementation of a number of action plans to reduce nitrogen losses from the agricultural production. NO_x emission has also decreased over time, mainly due to changes from solid based systems to slurry-based systems for both the dairy cattle and the swine production.

Table 5.17 Volatilization of NH₃-N and NO_x-N in housing and during storage, 1990-2020.

CRF Table 3.B(b)	1990	1995	2000	2005	2010	2015	2018	2019	2020
NH ₃ -N, housing and storage	41 607	38 257	38 355	38 642	32 286	29 248	28 757	26 916	26 894
NO _x -N, housing and storage	304	317	309	246	224	198	216	236	228
Sum, tons N	41 912	38 574	38 665	38 888	32 510	29 447	28 973	27 151	27 122

5.5.5 Time series consistency

The N₂O emission from manure management is estimated to 2.3 kt in 2020 of which only 0.4 kt is related to the indirect emission. The overall emission has decreased with 1.0 kt N₂O from 1990 – 2020 corresponding to 30 %. This decrease is mainly caused by a decreased emission from swine, which is driven by improvements in feed efficiency. The average nitrogen excretion per swine has decreased significantly (see Table 5.15) from 1990 due to the farmers' economic benefit of increased feed efficiency and due to environmental requirements.

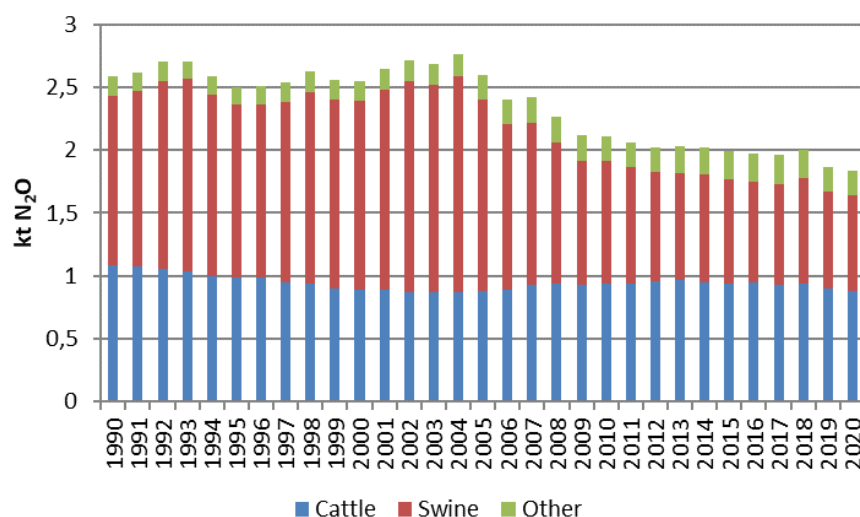

Figure 5.6 N₂O direct emission from manure management, 1990 - 2020.

5.6 Agricultural soils – direct N₂O emissions

5.6.1 Description

The emissions from agricultural soils – direct emissions, is emissions from inorganic N fertiliser, animal manure applied to soils, sewage sludge, other organic fertiliser applied to soils, urine and dung deposited by grazing animals, crop residues, mineralization/immobilization and organic soils. Emission from agricultural soils – direct emissions contribute, in 2020 with 77 % of the N₂O emission from the agricultural sector. The largest sources are manure and inorganic N fertiliser applied on agricultural soils. The emission has overall decreased 20 %.

5.6.2 Methodological issues

To calculate the N₂O emission the IPCC Tier 1 methodology is used, except from animal manure applied to soils and grazing animals, where Tier 2 methodology is used.

Emissions of N₂O are closely related to the nitrogen balance and all data concerning the evaporation of NH₃ and data for manure condition is applied from the national NH₃ emission inventory. This is described in detail in Albrektsen et al. (2021) and Annual Danish Informative Inventory Report (Nielsen et al., 2021).

5.6.3 Activity data

Area of agricultural land is shown in Annex 3D Table 3D-19.

Inorganic N fertiliser applied to soils

The amount of nitrogen (N) applied to soil by use of inorganic N fertiliser is estimated from sales estimates managed by the Danish Agricultural Agency and from the Danish fertiliser N accounts controlled by The Danish Agricultural Agency. As a part of the QA/QC procedure the sale statistics and the actually consumption registered in the Danish fertiliser N accounts is compared. This indicate an increasing difference for a range of years and especially a significant difference for 2016. The difference is caused by the growing import of inorganic fertilisers. The farmer are allowed to import fertiliser, if the consumption is related to own fields, but not for onward sale. Because of the increasing import, the amount of N applied to soil by use of inorganic N

fertiliser is based on Danish fertiliser N account from 2009 - 2016. For 2017, the sales estimates have been updated and sales information from more companies have been included (Danish Agricultural Agency, 2018). Therefore, the amount of N applied to soil by use of inorganic N fertiliser in 2017 and 2019-2020 is based on the sales estimates managed by the Danish Agricultural Agency (Danish Agricultural Agency, 2021). For 2018, a high uncertainty is indicated for the sales estimates (Skade, 2020, pers. Comm.) and therefore use of inorganic N fertiliser is based on the Danish fertiliser N accounts for 2018.

N applied to soil by use of inorganic N fertiliser

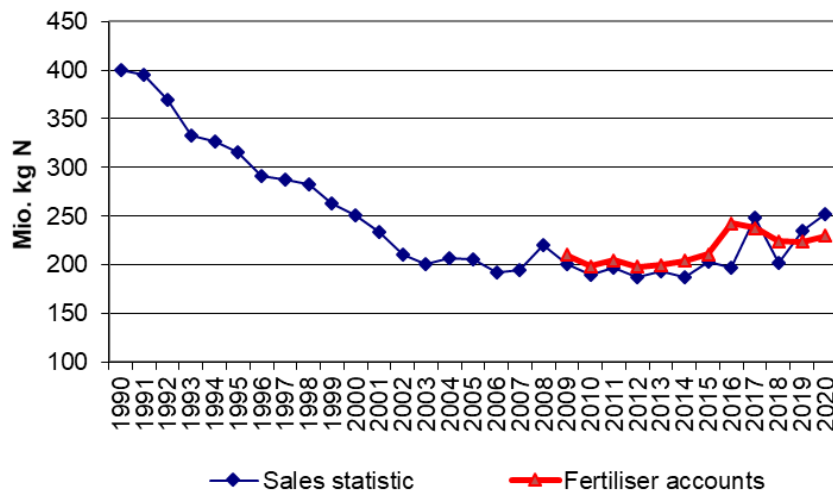

Figure 5.7 N applied from inorganic N fertiliser, sales statistic and N fertiliser account.

Table 5.18 shows the consumption of each fertiliser type for the inorganic fertiliser. The NH_3 emission factor for each fertiliser is given, based on the values from the EMEP/EEA Guidebook 2019. The emission factors are weighted values of EF for soil with normal pH (≤ 7) and high pH (> 7), in Denmark 79 % of the soils have a normal pH and 21 % have a high pH. The NH_3 emission depends on fertiliser type and the major part of the Danish emission is related to the use of ammonium nitrate and NPK fertiliser, where the emission factor is 0.019 and 0.059 kg $\text{NH}_3\text{-N}$ per kg N, respectively. The Danish $\text{Frac}_{\text{GASF}}$ is low compared to the IPCC default value. This is due to the small consumption of urea ($<1\%$), which has a high emission factor.

Table 5.18 Inorganic N fertiliser consumption 2020 and the NH₃ emission factors.

Fertiliser type	NH ₃ Emission factor ¹ kg NH ₃ -N per kg N	Consumption ² 1000 t N
Pure ammonium nitrate	0.019	7.89
Ammonium nitrate with/without sulphur	0.019	125.63
Ammonium nitrate-urea solutions	0.097	9.08
Urea	0.157	0.58
Calcium ammonium nitrate	0.010	10.84
Calcium and boron calcium nitrate	0.012	0.15
Ammonium sulphate	0.106	9.04
Ammonium sulphate nitrate	0.106	9.61
Liquid ammonia	0.022	6.15
Liquid nitrogen	0.097	3.73
NPK-fertiliser	0.059	59.24
NK fertiliser	0.019	1.28
Other NP fertiliser types	0.059	7.84
Other fertiliser with N	0.019	0.80
Total consumption of N in inorganic N fertiliser		251.87
National emission of NH ₃ -N, kt	10.01	
Average NH ₃ -N emission	0.04	
Frac _{GASF} ³	0.05	

¹) EMEP/EEA (2019), cool climate, weighted 79 % normal pH and 21 % high pH.

²) The Danish Agricultural Agency (2021).

³) Frac_{GASF} fraction of synthetic fertiliser N that volatilises as NH₃ and NO_x, kg N volatilised (kg of N applied).

The use of inorganic N fertiliser includes fertiliser used in parks, golf courses and private gardens. One percent of the inorganic N fertiliser can be related to these uses outside the agricultural area (Knudsen, 2011).

As a result of increasing requirements for improved use of nitrogen in livestock manure and reduce the nitrogen loss to the environment, the consumption of nitrogen in inorganic N fertiliser has decreased from 1990 to 2005 (Table 5.19). From 2005 to 2015, only small variation is seen in the consumption of N and emission of N₂O. In 2016-2020 the consumption and emission increases caused by a political agreement on Food and Agricultural package, adopted in December 2015 (MEFD, 2017). The purpose of the agreement was to establish better framework conditions for the agricultural production, to ensure opportunities for economic growth and increased exports and increased employment in interaction with nature and the environment. This agreement made it legally possible to use more nitrogen for some areas.

Table 5.19 Nitrogen applied as fertiliser to agricultural soils 1990 – 2020.

	1990	1995	2000	2005	2010	2015	2018	2019	2020
N content in inorganic N fertiliser, kt N	400	316	251	206	199	211	224	235	252
N ₂ O emission, kt N ₂ O	6.29	4.96	3.95	3.24	3.13	3.31	3.52	3.69	3.96

Animal manure applied to soils

The amount of nitrogen applied to soils is estimated as the N-excretion in housings which includes N from bedding. The total N-excretion in housings from 1990 to 2020 has decreased by 9 %.

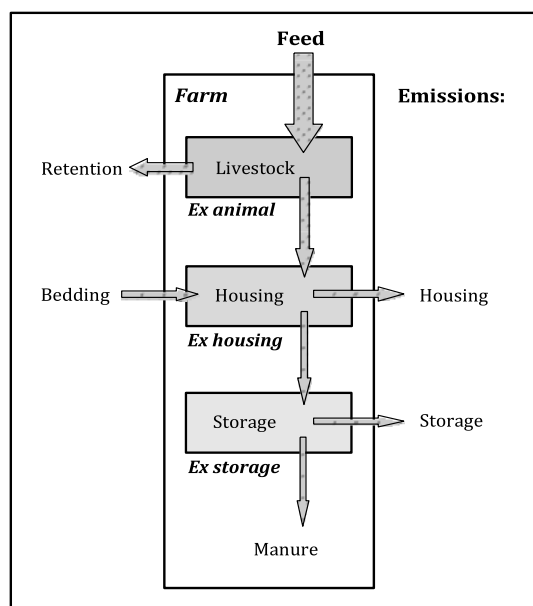

Figure 5.8 The flow dynamics of the Danish normative manure system, which quantifies nutrient content in livestock manure ex animal, ex housing and ex storage (Luostarinen and Kaasinen, 2016).

Table 5.20 Nitrogen applied as manure to agricultural soils 1990 – 2020.

	1990	1995	2000	2005	2010	2015	2018	2019	2020
N-excretion, housing, kt N	258	239	235	251	239	235	243	233	235
N in manure applied on soil, kt N*	212	197	195	212	208	209	217	209	211
N ₂ O emission, kt N ₂ O	3.33	3.10	3.06	3.33	3.27	3.28	3.41	3.28	3.31

*Including N from bedding.

Sewage sludge applied to soils

Information regarding the amount of sewage sludge applied on agricultural soil as fertiliser is based on information from the Danish Environmental Protection Agency, and covers the years 1990-2002, 2005, 2008-2009, 2013-2019 (MST, 2020). For 2020, the amount of sewage sludge applied is based on an average of the years 2017-2019. The N-content is assumed to be 4.75 kg N per kg dry matter (DEA, 2009).

Table 5.21 Emission from sewage sludge applied on agricultural soils 1990 – 2020.

	1990	1995	2000	2005	2010	2015	2018	2019	2020
Nitrogen in sewage sludge, t N	3 115	4 635	3 625	2 710	3 622	4 038	3 373	4 180	3 737
N ₂ O emission, kt N ₂ O	0.05	0.07	0.06	0.04	0.06	0.06	0.05	0.07	0.06

Other organic fertilisers applied to soils

The category, "Other", includes emission from sludge from industries, which is applied to agricultural soils as fertiliser and biomass other than manure treated in biogas plants.

Information about industrial waste applied on agricultural soils and the content of nitrogen is obtained from a series of reports published by the Danish Environmental Protection Agency, where recent official figures covering year 2001 (Petersen & Kielland, 2003). From 2005 and forward the amount of N from sludge from industries applied to soil, is based on the information registered in the Danish N fertiliser accounts controlled by the Danish Agricultural Agency. The N applied for years 2002- 2004 are interpolated.

Amount of nitrogen applied to soil from biomass treated in biogas plants (other than manure) are based on energy production in the biogas plants given in PJ and N per PJ were amount of N from NH₃ emission at the biogas plant are subtracted. Amount of NH₃ emission from feedstock at the biogas plants are reported in the waste sector in the Danish Informative Inventory Report (Nielsen et al., 2021). N per PJ are estimated to 7.5 ton N per PJ based on an average of N in feedstock and energy production in 2016-2019.

Table 5.22 Emission from sludge from industries applied on agricultural soils 1990 – 2020.

	1990	1995	2000	2005	2010	2015	2018	2019	2020
Nitrogen in industrial waste, t N	1 529	4 445	5 147	2 359	3 401	4 455	4 788	5 669	5 283
Nitrogen in other biomass, t N	5.3	9.8	16.8	24.0	29.4	44.6	96.8	120.2	155.3
N applied on soil	1 534	4 455	5 164	2 383	3 430	4 500	4 885	5 789	5 438
N ₂ O emission, kt N ₂ O	0.02	0.07	0.08	0.04	0.05	0.07	0.08	0.09	0.09

Urine and dung deposited by grazing animals

The amount of nitrogen deposited on grass is based on estimations from the NH₃ inventory (Nielsen et al., 2021). Information on grazing days is based on expert judgement from DCA and SEGES (Poulsen et al., 2001, Aaes, 2008, Clausen 2008). N-excretion on grass has decreased due to a reduction in the number of dairy cattle and days on grass.

Table 5.23 Nitrogen excreted on grass 1990 – 2020.

	1990	1995	2000	2005	2010	2015	2018	2019	2020
N-excretion, grass, kt N	34	35	34	26	22	21	21	21	22
N ₂ O emission, kt	1.00	1.05	1.01	0.73	0.61	0.59	0.59	0.58	0.60

Frac_{GASM}

The Frac_{GASM} express the fraction of N applied from all organic N fertilisers and dung and urine deposited by grazing animals volatilised as NH₃ and NO_x emission. Emission factors for NH₃ from the housing unit and storage are given in Annex 3D Table 3D-3 and 3D-4. The Frac_{GASM} has decreased from 0.18 in 1990 to 0.09 in 2020 (Table 5.24). This is the result of an active strategy to improve the utilisation of the nitrogen in manure.

Table 5.24 Frac_{GASM} 1990 – 2020.

	1990	1995	2000	2005	2010	2015	2018	2019	2020
N applied, kt N	250	242	238	243	237	238	247	240	242
NH ₃ -N and NO _x -N emission, kt N	46	35	29	23	22	20	21	20	21
Frac _{GASM}	0.18	0.15	0.12	0.09	0.09	0.09	0.08	0.09	0.09

Crop residues

The emission from crop residues is estimated based on the tier 1 methodology in the 2006 IPCC Guidelines. However, country specific estimates is used for crop yield and dry matter content. Default values for all parameters given in IPCC 2006 Table 11.2 are used except from dry matter fractions of the harvested product and the aboveground residue dry matter, both of which are based on national values. The default N₂O emission factor at 0.01 kg N₂O-N per kg N in crop residues is used.

The dry matter fraction in crops is based on a feedstuff table produced by SEGES, which has information for content of dry matter, fatty acid, protein, starch, sugar and energy for each crop type (SEGES, 2005). The total amount of dry matter in harvest product used to estimate the "Above-ground residue dry matter AG_{DM(T)}" is based on data from Statistics Denmark (DSt, 2021). The

$AG_{DM(T)}$ varies from year to year depending on the climate conditions – refer to Annex 3D, Table 3D-20.

Besides the cultivated area registered in Statistics Denmark, the inventory also include N content in catch crops, which has increased significantly, from approximately 200 000 hectare in 2010 to 500 000 hectare in 2020, in relation to decrease the N surplus from the fields to the aquatic environment. The total N content in crop residue for catch crop is estimated to 45 kg N per hectare, which is based on a first estimate provided by Peter Sørensen (Sørensen, 2021).

The amount of straw harvested and used for feeding, bedding and bio fuel in power plants is taken into account, because this quantity is removed from the fields. The amount of harvested straw is based on data from Statistics Denmark (DSt, 2021).

The total amount of nitrogen in crop residues is calculated and then the N-content in harvested straw is deducted. The N content in crop residues has increased from 157 million kg N in 1990 to 190 million kg N in 2020, which is a result of both increased total N content in crop residue and a lower amount of N from straw is removed from the fields. In 2018, N in crop residues is significantly decreased, this is due to very dry weather conditions, which resulted in very low yields of the crops.

Table 5.25 N-content in crop residue, 1990-2020.

Million kg N	1990	1995	2000	2005	2010	2015	2018	2019	2020
Total N in crop residue	180.7	169.0	174.9	180.9	191.0	208.5	161.2	216.6	205.1
N-content in harvested straw	24.2	20.1	17.4	14.6	14.8	13.6	16.3	15.8	14.8
CRF Table 3.D.4 N in crop residue	156.5	148.9	157.5	166.3	176.2	194.9	144.9	200.8	190.3

The N_2O emission is proportional to the N-amount in crop residues. Figure 5.9 shows the total N-content in crop residues allocated on the main crop types. Increase in N-content for maize and grass-clover mixtures in rotation is a result of increase of cultivated area. Some variations are seen from one year to another due to the annual climate conditions e.g. in 1992 and 2018 the spring and summer was extremely dry.

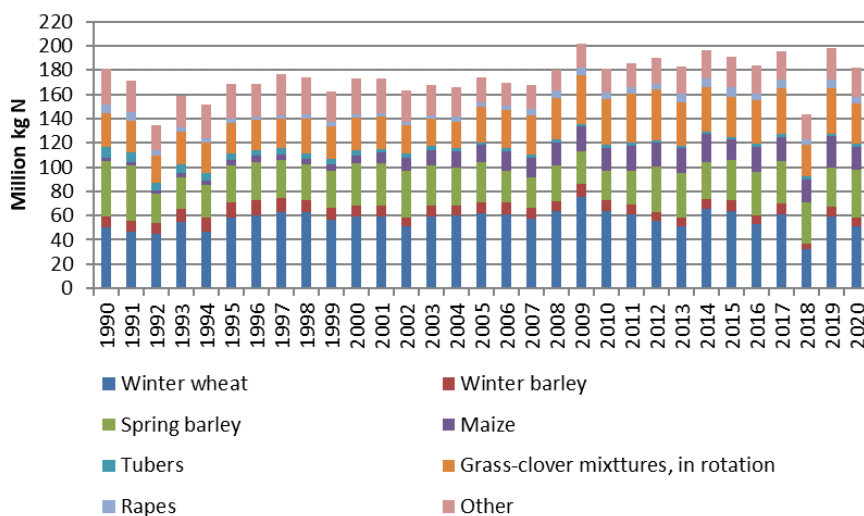

Figure 5.9 Total N in crop residue, 1990 – 2020.

Mineralization/immobilization associated with loss/gain of soil organic matter

The N mineralization from mineral soils associated with loss/gain of soil organic matter is estimated with a dynamical modelling tool - C-TOOL, which is used to estimate long-term changes in carbon from mineral soils. For a further description, see LULUCF, Section 6.3.1. Cropland and cropland management, mineral soils. C-TOOL is a 3-pooled dynamic model, where the approximate average half-live times for the three different pools, Fresh organic matter (FOM), Humified organic matter (HUM) and ROM (Resilient Organic Matter) are 0.6-0.7 years, 50 years and 600-800 years, respectively. The main part of biomass returned to soil each year is in the first and easiest degradable FOM pool. This pool consists of mainly fresh straw, fresh manure, root residues, fungi and small animals and fluctuates very much between years depending on the harvest yield and climatic conditions. The annual input to the FOM-pool is very close to the estimated annual amount of crop residues.

The estimated release of N₂O follows eq. equation 11.8, page 11.16 in the 2006 IPCC Guidelines. The N₂O formation is estimated from the annual changes in the HUM and ROM pool. Changes in the FOM pool is considered as being the same as crop residues incorporated in the soil and to avoid double-counting changes in the FOM is not included.

C-TOOL is subdivided into 44 combinations of regions and soil types. Within each subdivision are only losses included in the estimate. Only losses in soil carbon are included in the estimate. If a subdivision one year has an increase in the HUM and ROM pool the release of N₂O by default are zero as only losses are included, cf. eq. 11.8. A C:N-ratio of 10, which is common in the fertilized Danish agricultural soils are used for all soil types. The recommended default value in the 2006 IPCC Guidelines is 15.

Cultivation of organic soils

N₂O emissions from cultivation of organic soils are based on the area of organic soils of cropland, grassland and areas with no field identification, which are defined as grassland, shallow drained, nutrient-rich areas according to the 2013 Wetlands Supplement (IPCC, 2014). These areas are subdivided in areas with >12 % of soil organic carbon (SOC) and 6-12 % SOC. The Danish definition of organic soils are >10 % organic matter equivalent to app. 6 % SOC. It was defined in 1975 (Madsen et al., 1992). Agricultural soils in use under Danish conditions will normally have a carbon content of 1.5-3 % SOC (Taghizadeh-Toosi et al., 2014). This is the equilibrium state with a degradation condition and crop residue input. Drained land under agricultural use will therefore evidently approach a C content of 1.5-3 %. It is therefore assumed that the 6-12 % SOC soils will have losses of CO₂, N₂O and CH₄. Almost all measurements in the literature is performed on soils having >12 % OC. The areas with >12 % of SOC are multiplied by the default emission factor from Table 2.5 of the 2013 Wetland Supplement, IPCC (2014), which for >12 % SOC is 13 kg N₂O-N per ha cropland, 8.2 kg N₂O-N per ha deep-drained, nutrient-rich grassland and 1.6 kg N₂O-N per ha shallow-drained, nutrient-rich grassland. It has not been able to find any solid documentation for areas with 6-12 % SOC, so it is chosen to use 50 % of the values for soils having >12 % SOC, i.e. 6.5, 4.1 and 0.8 kg N₂O-N per ha, respectively.

EF is constant for all years 1990-2020. The area of organic soils is shown in Table 5.26. The area of organic soils has decreased from 1990 to 2020, see more in Chapter 6.3.1.

Table 5.26 Area of organic soils in ha, 1990-2020.

Year	1990	1995	2000	2005	2010	2015	2018	2019	2020
Cropland, >12 %**	54 082	50 967	47 851	44 736	40 718	33 518	31 060	31 339	30 348
Grassland, >12 %**	46 668	43 980	41 292	38 603	37 720	39 796	41 956	41 658	42 273
SN grassland*, >12 %**	0	0	0	0	0	1 461	1 438	1 415	1 442
Cropland, 6-12 %**	79 618	77 232	74 845	72 459	69 159	62 373	59 915	59 871	58 717
Grassland, 6-12 %**	34 922	33 875	32 829	31 782	32 839	35 240	37 106	36 980	37 649
SN grassland*, 6-12**	0	0	0	0	0	1 796	1 816	1 819	1 864

*SN grassland - shallow drained, nutrient-rich grassland.

** % SOC.

5.6.4 Emission factors

In the calculation of N₂O from agricultural soils, most of the N₂O emission factors are based on the default values given by the IPCC (IPCC, 2006). EF for cultivation of organic soils are based on the 2013 Wetlands Supplement (IPCC, 2014). A NH₃ and N₂O emission factor overview is presented in Table 5.27.

Table 5.27 Emission factors – NH₃ and N₂O from agricultural soils – direct emissions.

	NH ₃ emission factor (national data) Kg NH ₃ -N per kg N	N ₂ O emission factor (IPCC default value) kg N ₂ O -N per kg N
Inorganic N fertilisers	0.04*	0.01 ¹
Animal manure applied to soils	0.18**	0.01 ¹
Sewage sludge applied to soils	0.11 ³	0.01 ¹
Other organic fertilisers applied to soils	0.07 ³	0.01 ¹
Urine and dung deposited by grazing animals	0.05-0.35 ³	0.01-0.02 ¹
Crop residues		0.01 ¹
Mineralization/immobilization associated with loss/gain of soil organic matter		0.01 ¹
Cultivation of organic soils		0.8-13*** ²

*Varies from year to year.

**Varies from year to year, has decreased from 0.28 in 1990.

***Unit: kg N₂O-N per ha.

¹ IPCC (2006).

² IPCC (2014).

³ EMEP/EEA Guidebook (2019).

5.6.5 Time series consistency

Figure 5.10 shows the distribution and the development from 1990 to 2020 according to different N₂O sources. The yearly variations in emissions are mainly due to variations in the emission from inorganic N fertiliser and animal manure applied to soils. The main decrease is seen from 1990 to 2002 and is mainly due to the decrease in emission from inorganic N fertiliser, which is caused by increasing requirements for improved use of nitrogen in livestock manure and reduction of nitrogen loss to the environment. From 2003 to 2020 small yearly variations is seen, with increased emissions in 2008, 2016, 2017 and 2019 mainly due to increase in emission from inorganic N fertiliser. In 2018, the emission is decreased due to decrease in emission from inorganic N fertiliser and crop residues, which is due to the climate conditions were spring and summer was extremely dry.

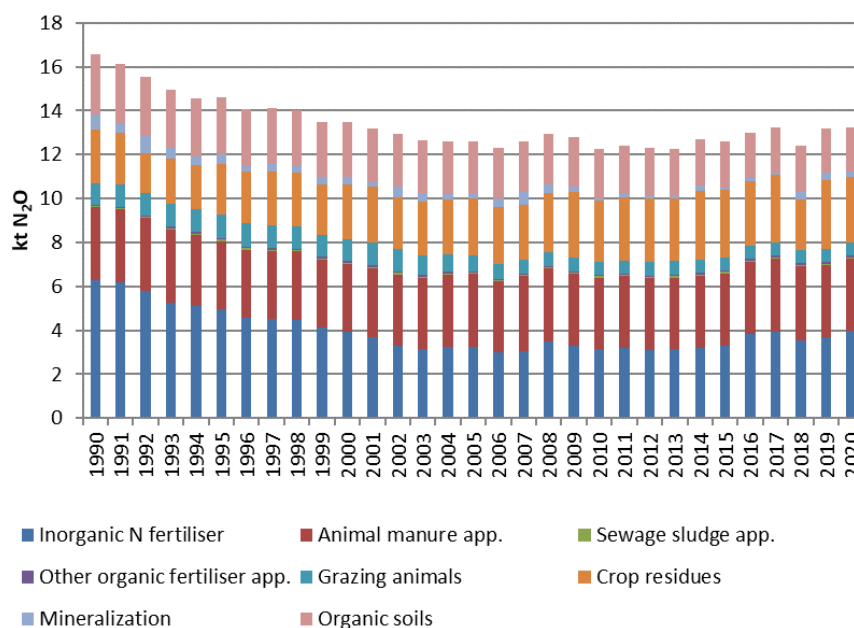

Figure 5.10 N₂O emissions from agricultural soils – direct emissions 1990 - 2020.

5.7 Agricultural soils –indirect N₂O emissions

5.7.1 Description

The emissions from agricultural soils – indirect emissions, are emissions from atmospheric deposition and from leaching and run-off. Agricultural soils – indirect emissions contribute, in 2020 with 10 % of the N₂O emission from the agricultural sector. The largest source is nitrogen leaching and run-off. The emission has decreased by 44 % from 1990 to 2020.

5.7.2 Methodological issues

To estimate the emission of N₂O from atmospheric deposition the Tier 2 methodology is applied. Principally same calculation methodology as IPCC guidelines is used, but based on national data for nitrogen leach to groundwater, watercourses and the sea. Due to atmospheric deposition, national data is used for the ammonia emission and the N-excretion.

The calculation of the N₂O emission from nitrogen leaching and runoff is based on IPCC model and a national model. Nitrogen, which is transported through the soil, can be transformed to N₂O. The IPCC recommends an N₂O emission factor of 0.0075 used, of which 0.0025 is for leaching to groundwater, 0.0025 for transport to watercourses (in IPCC definition called rivers) and 0.0025 for transport out to sea (in IPCC definition called estuaries). The N₂O emission from nitrogen leaching is a sum of the emission for all three parts calculated as:

$$N_2O_{leaching} = (N_{leach\ ground} \cdot EF_{ground} + N_{leach\ rivers} \cdot EF_{rivers} + N_{leach\ estuaries} \cdot EF_{estuaries}) \cdot \frac{44}{28}$$

In the Action Plans for the Aquatic Environment, nitrogen leaching to groundwater, rivers and estuaries has been estimated, see Table 5.28. The calculation of N to the groundwater is based on two different models– SKEP/Daisy and N-LES (Børgesen & Grant, 2003) carried out by DCA and DCE, Aarhus University (see overview of model in Annex 3D Figure 3D-1). SKEP/DAISY is a dynamical crop growth model taking into account the growth factors,

whereas N-LES is an empirical leaching model based on more than 1500 leaching studies performed in Denmark during the last 15 years. The models produce rather similar results for nitrogen leaching on a national basis (Waagepetersen et al., 2008).

5.7.3 Activity data

Atmospheric deposition

Atmospheric deposition includes all agricultural NH₃ and NO_x emission sources included in the Danish NH₃ emission inventory (Nielsen et al., 2021). Emission from atmospheric deposition from livestock manure, housing and storage, is reported in Sector 3B. Atmospheric deposition reported in Sector 3D includes the emission from livestock manure applied to soils and deposited during grazing, inorganic N fertiliser, growing crops, NH₃-treated straw used as feed, field burning of crop residues, sewage sludge and other organic fertiliser applied to agricultural soils.

The emission from atmospheric deposition has decreased from 1990 – 2020 because of the reduction in the total NH₃ and NO_x emission, from 80 316 tonnes of N in 1990 to 38 934 in 2020.

Table 5.28 NH₃ and NO_x emission 2020.

	t NH ₃ -N	t NO _x -N
Manure	17 756	2 566
Inorganic N fertilisers	10 012	3 066
Crops	4 421	
NH ₃ treated straw	130	
Burning of agricultural residues	113	
Sewage sludge	400	45
Other organic fertiliser	358	66
Emission total	33 190	5 744
N ₂ O emission, kt		0.61

Nitrogen leaching and Run-off

For N-leaching for ground water the SKEP/Daisy model has estimated the total N leached from 2003-2011 to be 149-175 thousand tonnes N, whereas N-LES model has estimated the total N leached to be 161-170 thousand tonnes in the same period. An average of the results from the two models is used in the emission inventory. From 2012 to 2019, data from N-LES is used. For 2020 no model estimations are available therefore are the N-leaching from ground water based on an average for 2015-2019.

Data concerning the N-leaching to rivers and estuaries are based on data from NOVANA (National Monitoring program of the Water Environment and Nature) received from the Department of Ecoscience, Aarhus University (Windorf et al., 2011, Windorf, 2013, Tornbjerg, 2021). NOVANA is a monitoring program, which includes monitoring of the ecologic, physic and chemical condition of water areas and transport of water and a range of substances, including N, to lakes and the sea (Wiberg-Larsen et al., 2010). These studies include measurements from 223 monitoring stations in all parts of Denmark and they have been carried out since the early 1990's. No data for 2020 are available yet and values are based on an average for 2015-2019.

Table 5.29 N leaching to groundwater, rivers and estuaries in kt, 1990-2020.

	1990	1995	2000	2005	2010	2015	2018	2019	2020
Groundwater	267	235	179	162	167	153	160	152	149
Rivers	98	97	91	59	59	87	60	79	73
Estuaries	101	89	78	55	57	71	50	74	63

Figure 5.11 shows leaching from groundwater estimated in relation to the nitrogen applied to agricultural soils as livestock manure, inorganic N fertiliser, sludge, crop residue and mineralization. The average proportion of nitrogen leaching from groundwater has decreased from around 35 % in the middle of the nineties to around 23 % in 2020. The decline is due to implementation of measures to avoid the nitrogen surplus in the agricultural production by improved nitrogen in manure, to use catch crops during winter and ban application of manure in winter. The reduction in nitrogen applied is particularly due to the fall in the use of inorganic N fertiliser. The main decrease in applied N to soil is seen from 1990 to 2002 due to the decrease in emission from inorganic N fertiliser. From 2003 to 2020, small yearly variations is seen with increase in 2008, 2016, 2017 and 2019 due to increase in N from inorganic N fertiliser. In 2018, a decreased is seen mainly due to decrease in N from inorganic N fertiliser and crop residues.

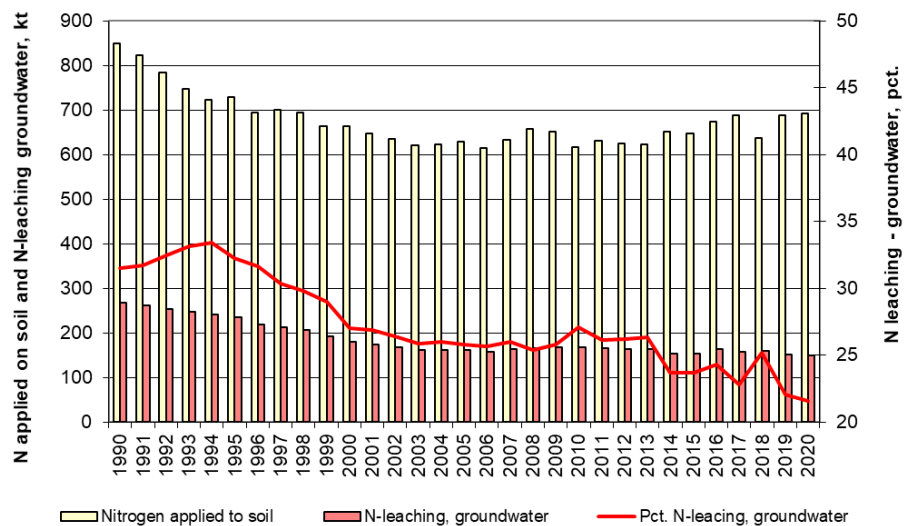

Figure 5.11 Nitrogen applied to agricultural soils and N-leaching, groundwater 1990-2020.

Frac_{LEACH}

The proportion of N input to soils lost through leaching and runoff (Frac_{LEACH}) used in the Danish emission inventory is in 2020 21 %; the default value of the IPCC is 30 %. Frac_{LEACH} has decreased from 1990 and onwards. At the beginning of the 1990s, manure was often applied in autumn. Now, the main part of manure application takes place in the spring and early summer, where there is nearly no downward movement of soil water. The decrease in Frac_{LEACH} over time is due to increasing environmental requirements and banning manure application after harvest.

5.7.4 Emission factors

In the calculation of indirect N₂O emissions from agricultural soils, the emission factors for both sources are based on the default values given by the IPCC (IPCC, 2006). See Table 5.30.

Table 5.30 Emission factors – N₂O from agricultural soils – indirect emissions.

	N ₂ O emission factor (IPCC default value) kg N ₂ O -N per kg N
Atmospheric Deposition	0.01
Nitrogen Leaching and Run-off	0.0075*

*Groundwater = 0.0025, rivers = 0.0025 and estuaries = 0.0025.

5.7.5 Time series consistency

Figure 5.12 shows the emission of N₂O from agricultural soils – indirect emissions. Both emissions from atmospheric deposition and leaching and run-off have decreased from 1990 to 2020. The dips and jumps are mainly due to change in emission from leaching and run-off.

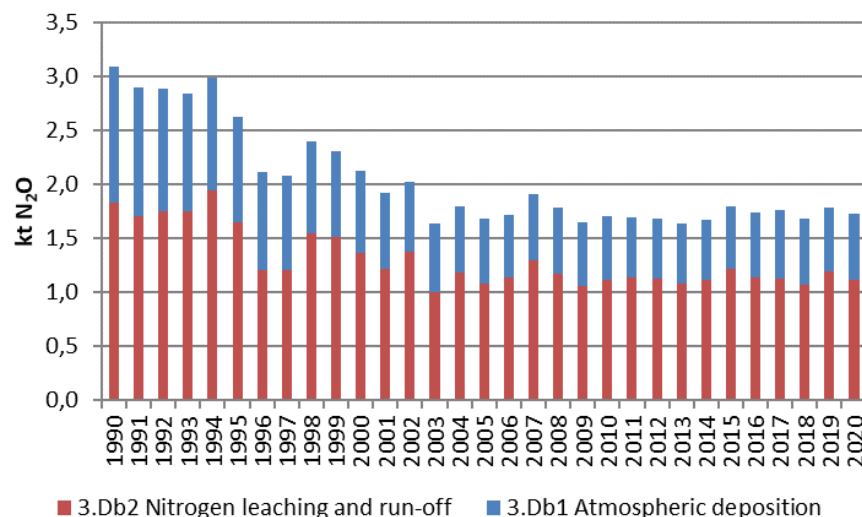

Figure 5.12 N₂O emissions from agricultural soils – indirect emissions 1990 – 2020.

5.8 Field burning of agricultural residues

5.8.1 Description

Field burning of agricultural residues in Denmark, has been prohibited since 1990 and may only take place in connection with production of grass seeds on fields with repeated production and in cases of wet or broken bales of straw. Field burning produces emissions of a wide variety of different pollutants and only the greenhouse gases are covered in this report. For emission of air pollutants, see the Danish Informative Inventory Report (Nielsen et al., 2021).

5.8.2 Methodological issues

Equation for calculating emissions:

$$E = BB \cdot \frac{EF}{1\,000\,000} \cdot FO$$

$$BB = CP \cdot FB \cdot FR_{DM}$$

Where:

- E = emission of compounds, kt
- BB = total burned biomass, kt DM
- CP = crop production, t
- FB = fraction burned in fields
- FR_{DM} = dry matter fraction of residue
- EF = emission factor, g per kg DM

FO = fraction oxidized

5.8.3 Activity data

The amount of burnt straw from the grass seed production is estimated as 15 % of the total amount produced. The amount of burnt bales of broken or wet bales of straw is estimated as 0.1 % of total amount of straw. Both estimates are based on an expert judgement by SEGES (Feidenhans'l, 2009, pers. comm.). The total amounts are based on data from Statistics Denmark.

5.8.4 Emission factor

Table 5.31 shows the emission factors used to estimate emissions of CH₄ and N₂O (Andreae and Merlet, 2001).

Table 5.31 Factors for estimating emissions of CH₄ and N₂O, 2020.

	Crop production	Fraction burned in fields	Dry matter (dm) fraction of residue	Total Biomass burned	EF	Fraction oxidized	Emission
	t			kt dm	g per kg dm		kt
CH ₄ Mixed cereals	6 044 000	0.001	0.85	5 137	2.7	0.90	0.012
CH ₄ Straw from seeds of grass	456 000	0.15	0.85	58 140	2.7	0.90	0.141
N ₂ O Mixed cereals	6 044 000	0.001	0.85	5 137	0.07	0.90	0.0003
N ₂ O Straw from seeds of grass	456 000	0.15	0.85	58 140	0.07	0.90	0.004
Total CO ₂ eqv							5.03

5.8.5 Time series consistency

The emission of CH₄, N₂O, NO_x, CO, CO₂, SO₂ and NMVOC from field burning contributes with less than 1 % of the national emission.

5.9 CO₂ from liming

5.9.1 Description

The emission of CO₂ from liming in Denmark occurs during liming with limestone. The emission of CO₂ from liming contributes with 98 % of the CO₂ emission from the agricultural sector.

5.9.2 Methodological issues

A Tier 1 method as given in the 2006 IPCC Guidelines is used.

5.9.3 Activity data

The amount of limestone used is based on the sales statistics. The amount used on the agricultural soils is collected by SEGES (Hansen, 2021). The amount of limestone used in private gardens is based on expert judgement (Andersen, 2004, pers. comm.).

5.9.4 Emission factors

The emission factor is 0.44 kt CO₂ per kt limestone and is the same for all years 1990 to 2020. It is based on the molecular weight for CaCO₃ and CO₂.

$$EF = \frac{M_{CO_2}}{M_{CaCO_3}}$$

Where:

EF Emission factor for CO₂ from liming
M_i Molecular weight for *i* molecule

5.9.5 Time series consistency

The emission of CO₂ from liming has overall decreased by 56 % from 1990 to 2020. As shown in Figure 5.13, the main decrease is occurring from 1990 to 1997, and is due to a change in fertiliser practice with increase in use of manure as fertiliser and decrease in use of inorganic N fertiliser. When ammonium nitrogen is used as fertiliser and a loss of nitrogen from the soil is occurring, it causes an acidification of the soil and use of liming could be necessary to even out pH in the soil (Knudsen, 2004).

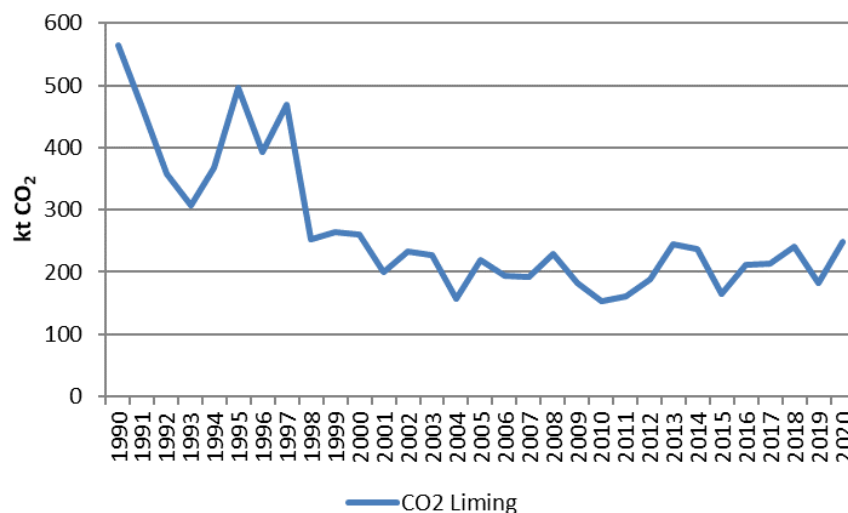

Figure 5.13 CO₂ emission from liming, 1990 to 2020.

5.10 CO₂ from urea

5.10.1 Description

Emission of CO₂ from use of urea contributes with less than 1 % of the CO₂ emission from the agricultural sector.

5.10.2 Methodological issues

A Tier 1 method as given in the 2006 IPCC Guidelines is used.

5.10.3 Activity data

The amount of urea used on agricultural soils is based on sales estimates from the Danish Agricultural Agency (Danish Agricultural Agency, 2021).

5.10.4 Emission factors

The default emission factor of 0.20 kg C per kg urea given in the 2006 IPCC Guidelines is used.

5.10.5 Time series consistency

Figure 5.14 shows the emission of CO₂ from use of urea. The emission has decreased with 91 % from 1990 to 2020, but the main decrease is occurring from 1990 to 2000. From 2003 to 2020, the emission is almost unaltered. The decrease is due to decrease in the use of urea.

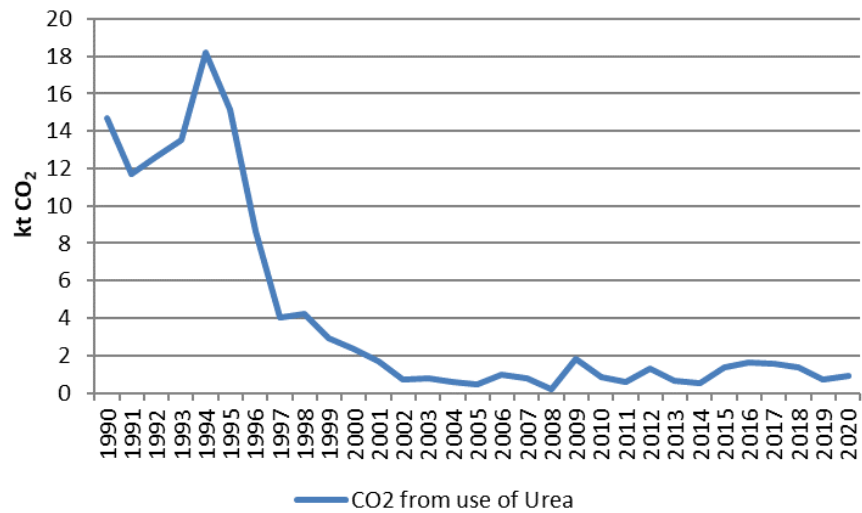

Figure 5.14 Emission of CO₂ from use of urea, 1990 to 2020.

5.11 CO₂ from other carbon-containing fertilisers

5.11.1 Description

Use of other carbon-containing fertilisers is in Denmark the use of calcium ammonium nitrate (CAN). The emission of CO₂ from CAN contributes with 2 % of the CO₂ emission from the agricultural sector.

5.11.2 Methodological issues

A Tier 1 method as given in the 2006 IPCC Guidelines is used.

5.11.3 Activity data

The amount of CAN used on agricultural soils is based on sales estimates from the Danish Agricultural Agency (Danish Agricultural Agency, 2021).

5.11.4 Emission factors

The emission factor is 0.026 kg C per kg CAN and the same for all years 1990 to 2020. It is based on the molecular weight:

$$EF = \left(\frac{\text{kg CaCO}_3}{\text{kg CAN}} / 100 \right) / M_{\text{CaCO}_3} \cdot M_C$$

$$\frac{\text{kg CaCO}_3}{\text{kg CAN}} = (100 - M_{\text{NH}_4\text{NO}_3}) / M_{\text{CaMg}(\text{CO}_3)_2} \cdot M_{\text{CaCO}_3} \cdot 2$$

Where:

EF Emission factor for CO₂ from CAN

M_i Molecular weight for *i* molecule

5.11.5 Time series consistency

Figure 5.15 shows the emission of CO₂ from use of CAN. The emission has decreased with 89 % from 1990 to 2020, but the main decrease is occurring from 1990 to 1999. From 2000 to 2020, the emission is almost unaltered except from in 2015 where an increase is seen. The change is due to change in the use of CAN.

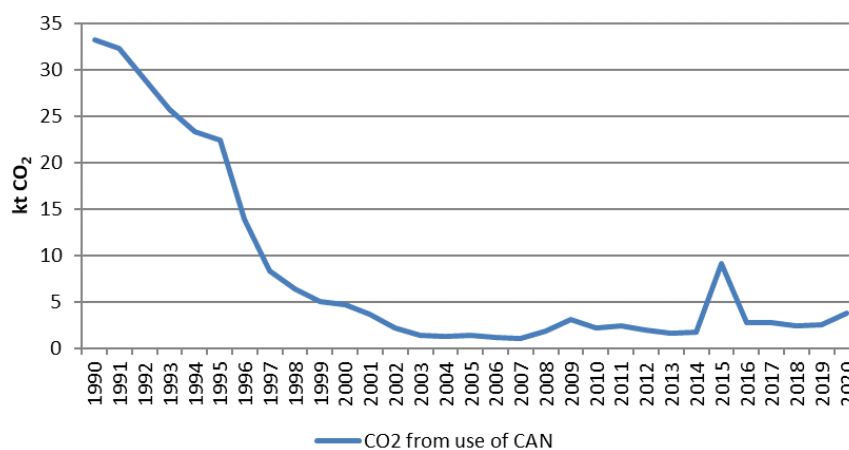

Figure 5.15 Emission of CO₂ from use of CAN, 1990 to 2020.

5.12 Uncertainties

Uncertainties are calculated using Approach 1.

5.12.1 Uncertainty values

The main part of the Danish emissions depends on the livestock production, and uncertainties, such as number of animals, feeding consumption, normative figures etc., are relatively low. The number of animals is estimated by Statistics Denmark and all cattle, sheep and goats have their own ID-number (ear tags), which is an important reason for a low uncertainty level. The uncertainties for the most important livestock categories are relatively low e.g. for swine and cattle the uncertainties is estimated to 1.3 % and 0.9 %, respectively (DSt, 2021). The uncertainty is higher for less important animal groups, e.g. fur bearing animals (3.2 %), poultry, horses and sheep (10.4 %) (DSt, 2021). The overall uncertainty for number of animals is estimated to 2 %.

The Danish Normative System for animal excretions is based on data from SEGES and DCA, Aarhus University. SEGES is the central office for all Danish agricultural advisory services and are participating in a great deal of research as well as the collection of efficacy reports from Danish farmers for dairy production, meat production, swine production, etc. to optimise productivity in Danish agriculture. In total, feeding plans from 15-18 % of Danish dairy production, 25-30 % of swine production, 80-90 % of poultry production and approximately 100 % of fur production are collected annually. These basic feeding plans are used to develop the standard values of the “Danish Normative System”. However, due to the large number of farms included in the norm figures, the arithmetic mean can be assumed as a very good estimate with a low uncertainty. In the normative standards (Børsting et al., 2021) uncertainty values are indicated for emission measurements in housing and varies from 15 -25 %.

Data for hectares under cultivation is estimated by Statistics Denmark and the uncertainties are based on their estimates. For the most common crops, winter wheat the uncertainty are 1.1% estimated by DST (2021) and a less common crop type as spring wheat is estimated to 5.8%. The overall uncertainties for the total cultivated area are below 5 %.

For CH₄ emission from enteric fermentation, the uncertainty for activity data is the uncertainty for numbers of animals and the uncertainty for the emission factor is based on IPCC 2006. For the emission of CH₄ from manure management, the uncertainty for the activity data is the uncertainty for number of

animals and the distribution of housing types. The uncertainty for the emission factor is based on uncertainty given in IPCC 2006.

For the N₂O emission uncertainties, the activity data uncertainty is based on the uncertainties for NH₃ emission due to the high correlation between the NH₃ and N₂O emission (Nielsen et al., 2021). Uncertainties related to the N₂O emission factor are based on the IPCC 2006. See Table 5.32 for uncertainty values for the agricultural sector.

Table 5.32 Uncertainties values for activity data and emission factors for CH₄, N₂O and CO₂.

CRF category	Emission factor	Uncertainties value for activity data, %	Uncertainties value for emission factor, %
<u>3A Enteric Fermentation</u>	CH ₄	2	20
<u>3B Manure Management</u>	CH ₄	5	20
	N ₂ O	20	100
3B5 Atmospheric Deposition	N ₂ O	15	100
<u>3D Agricultural Soils</u>			
3Da Direct soil emissions			
3Da1 Inorganic N fertiliser	N ₂ O	3	300
3Da2a Animal manure applied to soils	N ₂ O	25	300
3Da2b Sewage sludge applied to soils	N ₂ O	15	300
3Da2c Other organic fertiliser applied to soils	N ₂ O	20	300
3Da3 Urine and dung deposited by grazing animals	N ₂ O	10	300
3Da4 Crop Residues	N ₂ O	25	300
3Da5 Mineralization	N ₂ O	50	300
3Da6 Cultivation of organic soils		50	300
3Db Indirect soil emissions			
3Db1 Atmospheric deposition	N ₂ O	15	500
3Db2 Leaching	N ₂ O	20	300
<u>3F Field Burning of Agricultural Residue</u>	CH ₄	25	50
	N ₂ O	25	50
<u>3G Liming</u>	CO ₂	5	100
<u>3H Urea application</u>	CO ₂	3	100
<u>3I Other carbon-containing fertilisers</u>	CO ₂	3	100

5.12.2 Result of the uncertainty calculation

Table 5.33 shows the result of Approach 1 uncertainty calculation for 2020. The overall uncertainty calculation for the agricultural sector based on Approach 1 is estimated to ± 53 %.

The lowest uncertainties are seen for CH₄ emission from enteric fermentation and manure management and the highest for emission from atmospheric deposition.

Table 5.33 Uncertainty calculation, 2020.

Uncertainty		Emission, kt CO ₂ eqv.	Uncertainty, % Lower and upper (±)
3 Agriculture total	CH ₄ , N ₂ O and CO ₂	11 268	53
3A Enteric Fermentation	CH ₄	3 680	20
3B Manure Management	CH ₄ and N ₂ O	2 871	25
	CH ₄	2 198	21
	N ₂ O	546	102
3B5 Atmospheric deposition	N ₂ O	127	101
3D Agricultural Soils	N ₂ O	4 458	116
3Da Direct soil emissions	N ₂ O	3 942	144
3Da1 Inorganic N fertiliser	N ₂ O	1 179	300
3Da2a Animal manure applied to soils	N ₂ O	987	301
3Da2b Sewage sludge applied to soils	N ₂ O	17	300
3Da2c Other organic fertiliser applied to soils	N ₂ O	25	301
3Da3 Urine and dung deposited by grazing animals	N ₂ O	178	300
3Da4 Crop Residues	N ₂ O	891	301
3Da5 Mineralization	N ₂ O	64	304
3Da6 Cultivation of organic soils	N ₂ O	600	304
3Db Indirect soil emissions	N ₂ O	516	263
3Db1 Atmospheric deposition	N ₂ O	182	500
3Db2 Leaching	N ₂ O	334	301
3F Field Burning of Agricultural Residues	CH ₄ and N ₂ O	5	45
	CH ₄	4	56
	N ₂ O	1	56
3G Liming	CO ₂	250	100
3H Urea application	CO ₂	1	100
3I Other carbon-containing fertilisers	CO ₂	4	100

5.13 Quality assurance and quality control (QA/QC)

5.13.1 Verification

Enteric fermentation

Tier 2/Country Specific compared to IPCC Tier 2 method

A comparison between the IPCC Tier 2 methodology and Denmark's Tier 2/Country Specific (CS) calculation method for enteric fermentation is made. In the IPCC Guidelines default values are given for dairy cattle and non-dairy cattle, therefore a comparison is made for these groups.

Calculations of IEFs are made by IPCC Tier 2, with both default and national values for Y_m , and Denmark's Tier 2/CS method. A comparison between IEFs (Table 5.34) shows that the Danish method gives a value for dairy cattle, which is 1 % lower than the IPCC Tier 2 method and for non-dairy cattle, the Danish method gives a value which is 4 % higher than the IPCC Tier 2.

Table 5.34 IEFs for enteric fermentation calculated by different methods, 2020.

kg CH ₄ per animal per year	Tier 2 (IPCC Y_m)	Tier 2 (DK Y_m)	Tier 2/CS
Dairy cattle	159.0	141.0	157.4
Non-dairy cattle	39.1	39.1	40.9

The three different Tier 2 calculations for non-dairy cattle all show an IEF between 39.1-40.9 kg per head per year, which indicates that the Tier 2/CS used

in the Danish inventory is reasonable. However, these values are lower compared to the Tier 1 default value at 57 kg per head per year given in the IPCC 2006, Table 10.11, which can be explained by a lower animal weight/lower feed intake.

The lower value for the IEF for dairy cattle is mainly due to a lower Y_m because GE are higher in Danish method (Table 5.35). The Danish values for feed consumption are based on the Danish normative figures, the normative data are based on actual efficacy feeding controls or actual feeding plans at farm level. The national Y_m have been lowered in 2018 and 2020 due to change in feeding composition and fodder practice for Danish dairy cattle. More info on GE calculations and Y_m is included in Chapter 5.3.2.

Table 5.35 GE for dairy cattle calculated by different methods, 2020.

MJ per animal per day	Tier 2 (IPCC Y_m)	Tier 2/CS
Dairy cattle	372.8	415.5

Manure management

Nitrogen excretion rates compared to the IPCC defaults

For non-dairy cattle, horses, poultry and mink nitrogen excretion rates given by 2006 IPCC Guidelines and the Danish nitrogen excretion rates are at the same level. For dairy cattle Denmark has a higher nitrogen excretion rate than given in 2006 IPCC Guidelines, this is probably due to a high feed consumption to give high milk production per cow at Danish dairy cattle. The nitrogen excretion rate for swine reported in the CRF is an average for the subcategories sows, weaners and fattening pigs, 7.3 kg N per animal per year in 2020. For sows the nitrogen excretion rates given by 2006 IPCC Guidelines and the Danish nitrogen excretion rates are at the same level. However, the Danish nitrogen excretion rate is lower than the default given in the 2006 IPCC Guidelines for fattening pigs and this is due to the high feed efficiency in Danish swine and the high share of weaners. For sheep and goats, the Danish nitrogen excretion rates are lower than given in 2006 IPCC Guidelines.

The animal weights are not used directly for estimating emissions because excretion rates are given in the Danish normative figures per animal (Børsting et al, 2021). The weights for animals given in the CRF Tables are mainly for the most dominating subcategory.

Table 5.36 Nitrogen excretion rates from the 2006 IPCC Guidelines and for Denmark, 2020.

IPCC	kg N per 1000 kg animal per day	Weight kg (DK)	kg N per animal per year	Denmark	kg N per animal per year
Dairy cattle	0.48	580	101.6	Dairy cattle	156.4
Other cattle	0.33	320 ¹	38.5	Non-dairy cattle	42.5
				Swine – weighted fattening pigs and weaners	5.8
Swine - market	0.51	113 ²	21.0	Swine - fattening pigs	10.1
				Swine - weaners	2.3
Swine - breeding	0.42	140	21.5	Swine - sows	23.8
				Sheep – weighted	6.6
Sheep	0.85	70 ³	21.7	Sheep - mother	12.8
				Sheep - lambs	2.5
Goats	1.28	60 ⁴	28.0	Goats	16.8
				Horses – weighted	43.8
Horses	0.26	600 ⁵	56.9		
		504 ⁵	47.8		
Hens	0.96	2	0.7	Hens	1.1
Pullets	0.55	1.4	0.3	Pullets	0.1
Broilers	1.1	2	0.8	Broilers	0.4
Turkeys	0.74	14	3.8	Turkeys	2.6
Ducks	0.83	3.7	1.1	Ducks	1.0
Mink			4.59	Mink	5.5
Fox			12.09		

¹ Weight of hifers.

² Weight of fattening pigs. Weaners weigh 6.7-31 kg (Børsting et al, 2021).

³ Weight of mother sheep including 1.5 lambs (Børsting et al, 2021).

⁴ Weight of mother goat including 1.5 kid (Børsting et al, 2021).

⁵ 600 kg is the weight of the most dominating group of horses, while 504 kg are the average weight for all horses.

Nitrogen excretion compared to DCA numbers

DCA, who estimates the normative figures for nitrogen excretions per animal, also estimate the total amount of nitrogen excreted for the years 2005-2016 (Blicher-Mathiesen et al., 2018).

A comparison of the total nitrogen excretion estimated by DCE for the emission inventory and that estimated by DCA is made, see Figure 5.16. It is seen that the trend for the total nitrogen excretion almost follow the same pattern for both estimations. The nitrogen excretion estimated by DCE are a bit higher than the nitrogen excretion estimated by DCA and this is probably due to the number of animals. The inventory includes animals on small farms, which are not included in numbers from DSt (horses, sheep and goats) and also some animal categories, which are not included in the normative system (deer, pheasants and ostriches). Another reason for the difference between the two estimations could be differences in definitions for grazing – e.g. days on grass vs. days in housings.

The comparison between the total N-excretion estimated by DCE and DCA, shows the same trend, and based on this, it is concluded that the total N-excretion estimated by DCE for all years 1985-2020 used in the national inventory, seems reliable.

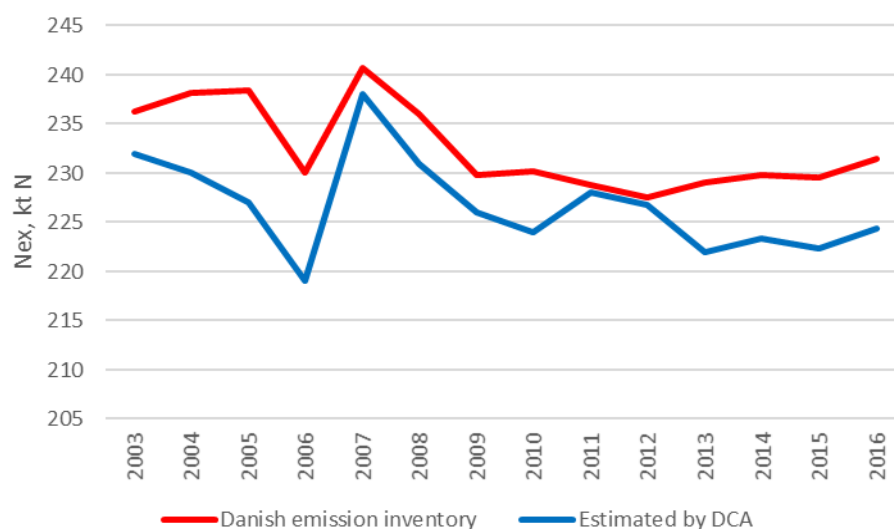

Figure 5.16 Comparison of nitrogen excretion estimated by DCE and DCA.

MCF compared to IPCC default

The comparison of MCF given in IPCC 2006 and the MCF used in the Danish inventory are shown in Annex 3D, Table 3D-15. For liquid untreated and bio-gas treated manure for cattle and swine, a national estimated MCF is used (see Annex 3D Chapter 3D-1). For other animal categories and manure types, the MCF is based on values from the 2006 IPCC Guidelines.

Distribution of animals on housing types

Table 5.37 shows the distribution of animals on different manure management systems given in IPCC 2006 and the Danish national distribution. The main part of Danish dairy cattle is housed in systems with liquid/slurry manure whereas the distribution given by IPCC, for a great part, is housed in systems with solid manure. For non-dairy cattle, the percentage of animal in systems with liquid/slurry and pasture, range and paddock are almost the same in IPCC and in Denmark. IPCC has a great part of non-dairy cattle on systems with solid manure, whereas this part of non-dairy cattle in the Denmark is in systems with deep litter that is the manure management system other. For swine, the main part of the animals in Denmark is housed in systems with liquid/slurry, whereas the main part in IPCC is in systems with pit > 1 month.

Table 5.37 Distribution of animals on manure management systems IPCC 2006 vs. national.

	IPCC 2006			DK 2020		
	Dairy cattle	Other cattle	Swine	Dairy cattle	Non-dairy cattle	Swine
Lagoon	0	0	8.7	0	0	0
Liquid/slurry	35.7	25.2	0	62.4	31.4	89.5
Solid storage	36.8	39	13.7	0.8	0.3	0.1
Drylot	0	0	0	0	0	0
Pasture, range and paddock	20	32	-	4.9	28.9	0.4
Daily spread	7	1.8	2	0	0	0
Digester	0	0	0	24.3	0	8.5
Burned for fuel	0	0	-	0	0	0
Other	0.5	2	3	7.6	39.3	1.5
Pit < 1 month	-	-	2.8	0	0	0
Pit > 1 month	-	-	69.8	0	0	0

Calculation of VS based on GE and DM

Figure 5.17, 5.18 and 5.19 show a comparison of the calculation of VS based on gross energy (GE) and manure. In the Danish inventory, the calculation of VS is based on manure. For dairy cattle, the two calculations follow the same trend, but the VS based on manure are higher than the one based on GE. This is mainly due to the inclusion of bedding.

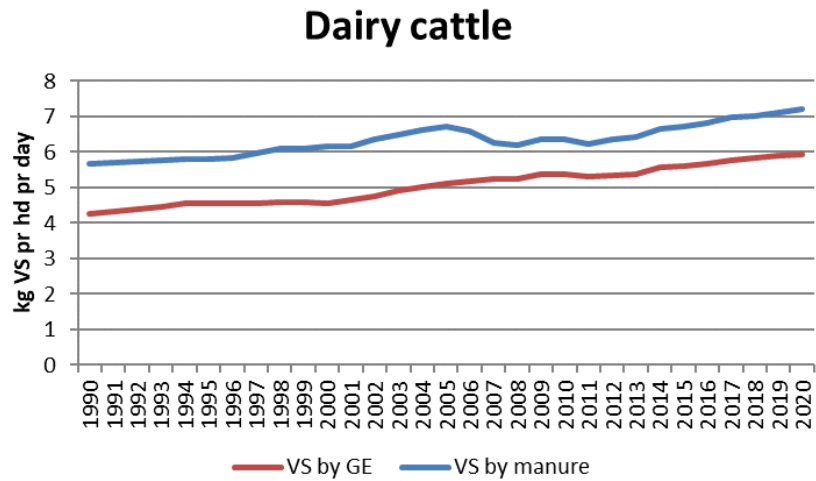

Figure 5.17 VS for dairy cattle based on GE and on manure.

For all non-dairy cattle, VS based on manure are higher than the one based on GE and this is mainly due to the inclusion of bedding. For bulls, VS based on manure, increase in 2001-2011 due to increase in the share of animals in housings with deep litter. From 2012 to 2013, the VS for bulls decrease due to reduction of bedding per animal per day given in the normative figures. VS based on manure for suckling cattle change due to increase in amount of manure per animal and decrease in dry matter (DM) in the manure for animals on some housing types. The decrease from 2006 to 2007 is due to division of suckling cattle in three wait classes with different amount of bedding per animal per day.

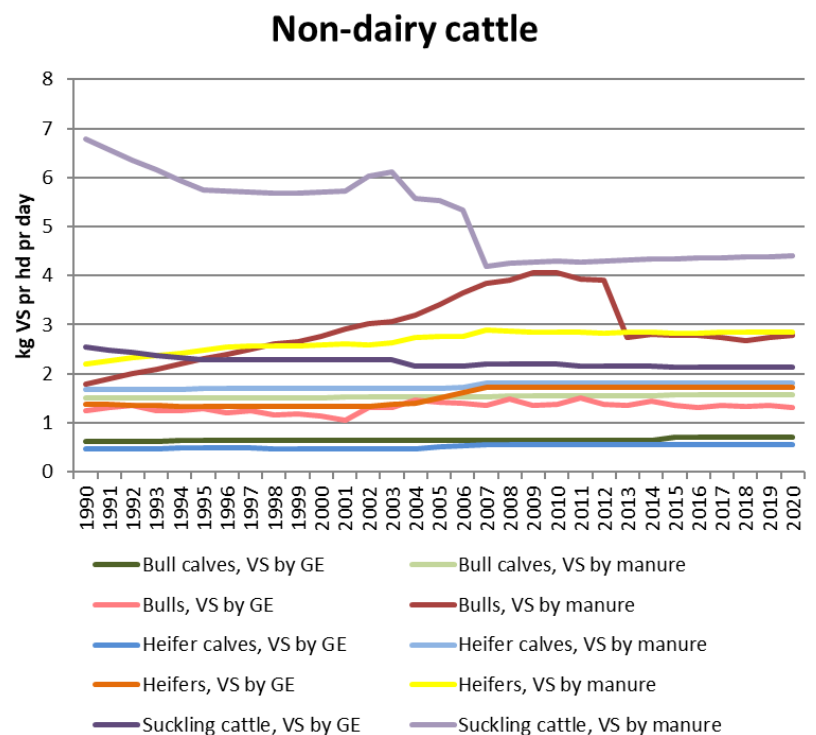

Figure 5.18 VS for non-dairy cattle based on GE and manure.

VS for weaners and fattening pigs based on both GE and manure follow the same trend, but the VS based on GE are a bit higher than VS based on manure. This is mainly due to high feed efficiency in Danish swine. The decrease in VS based on manure for sows in 2004-2007 is due to decrease in the share of animals in housings with bedding.

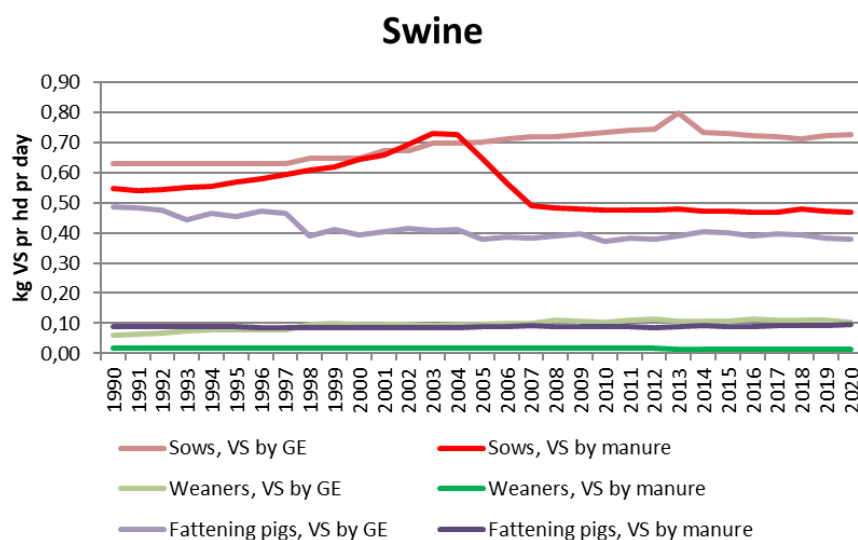

Figure 5.19 VS for swine based on GE and manure.

5.13.2 QA/QC plan

A first step of development and implementation of a general QA/QC plan for all sectors started in 2004 which is described in a publicised manual (Sørensen et al., 2005). The manual describes the concepts of quality work and how to handle quality management by using Critical Control Points and a list of Point of Measurements (Nielsen et al., 2013). For more detailed information of the structure in the general QA/QC plan, please refer to Chapter 1.6 for QA/QC.

A complete list Points of Measures (PM) are given in Table 1.2. PM related to the agricultural inventory is listed below in Chapter 5.13.3 and are primarily connected to data storage and data processing level 1. For PM not mentioned below please refer to Chapter 1.6.

The QA/QC work specific for the agricultural sector is still improved. The overall framework regarding a QA/QC plan for agriculture are constructed in form of six stages and each stage focus on quality assurance and quality check in different part of the inventory process. A more detailed set up for stage I, II and III are developed – refer to Annex 3D Table 3D-21.

The QA/QC procedure is divided in six stages as listed below:

Table 5.38 Stages of QA/QC procedure.

Stage I	Check of input data - check of data input in IDA are consistent with data from external data suppliers
Stage II	Check of IDA data – overall - check of recalculations for total emissions compared with the latest submission - check of total emissions for the total CO ₂ eqv. and for each compound
Stage III	Check of IDA data – specific - check of annual changes of activity data, emission factors, IEF and other important variables as GE, Nex, housing system distribution, grazing days
Stage IV	Check by comparing calculation with estimates from other institutions - the total Nex for all livestock production estimated by DCA - the Register for fertilization controlled by the Danish Agricultural Agency
Stage V	Check of data registered in CRF - compare data in CRF with data from IDA
Stage VI	Check of the inventory in general (external review) - check that data is used correctly - check the methodology and the calculations

Stage I: Check of input data

At stage I, it is checked that all input data in IDA are consistent with data from the external data suppliers. Data from the Statistics Denmark have to be checked for the livestock production, slaughter data for poultry and pigs, check of land use and crop yield. Data input from the DCA have to be checked for feed intake, N-excretion, manure production, dry matter content and grazing days. Data from the Danish Agricultural Agency: distribution of housing systems and the use of nitrogen in inorganic N fertiliser.

Stage II: Check of IDA data - overall

Stage II includes check of the overall calculations in IDA, where the first step is to compare the inventory with the last reported emission inventory - submission 2021. In the case where an error covers the whole time series, it can be difficult to identify this error by checking the changes in inter-annual values. Therefore, a check of recalculations is needed.

Next step in stage II is a check of total emissions of CH₄, N₂O, NMVOC and the other compounds, which are related to the field burning of agricultural residues. For each compound, a check of trends of time series 1990-2020 and inter-annual changes is provided. Significant jumps or dips from one year to another could indicate an error - otherwise it has to be explained.

Stage III: Check of IDA data - specific

At stage III, a check of specific variables in IDA is provided for both inter-annual changes and trends for the entire time series. Variables includes activity data, emission factors, IEFs and other important key variables such as feed intake, GE, Nex and housing system distribution.

Stage IV: Check by comparing calculation with estimates from other institutions

The purpose of stage IV is to verify the calculations in IDA, as far as external data estimations are available. For other purposes DCA for some years calculate the overall N excretion from the total livestock production in DK, this is compared with the estimated in the emission inventory, see Chapter 5.13.1.

Another possibility to check some of the IDA estimations is the information in the fertiliser accounts controlled by The Danish Agricultural Agency. Farmers with more than 10 animal units is registered and have to keep accounts of the N content in manure, received manure or other organic fertiliser. These comparisons will properly show some differences, which not necessarily indicate an error, but the most important cause of the difference has to be identified.

Stage V: Check of data registered in CRF

Stage V primarily focuses on the last reported year 2020 and the base year (1990), where all activity data, emissions and IEFs are checked. Furthermore, CRF sum emissions are checked with sum emissions in IDA. If an error is detected a more detailed check is done to find the reason for the error.

Stage VI: Check of the inventory in general

A detailed description of the methodology used to calculate the Danish agricultural emissions is published as a sectorial report for agriculture (Albrektsen et al., 2021). General checks of the inventory include considerations of which data input is used, how they are used in the calculations and whether more accurate data are available. The review of the sectorial report addresses these issues and is a most valuable part of the QA of the agricultural sector.

Status for the QA/QC plan

The framework for working out a specific QA/QC plan for the agricultural sector is complete. Stage I-III is done as part of the process of inventory preparation, which has reduced the number of errors in the CRF and in this way meet the ERT recommendations. A more detailed list showing the checked variables of stage I – III is provided in Annex 3D Table 3D-21.

Concerning the stage IV we have provide some random checks but need to provide a more systematic check. We are aware of some external calculations, which can be compared with the estimations in IDA – e.g. some comparisons with the Register of Fertilisation administrated by the Danish Agricultural Agency can be provided.

Stage VI is implemented. Five reports describing the methodology in calculation of agricultural emissions in details are published (Mikkelsen et al., 2006, Mikkelsen et al., 2011, Mikkelsen et al., 2014, Albrektsen et al., 2017 and Albrektsen et al., 2021). All reports have been reviewed by experts not involved with the preparation of the emission inventory. The 2021 report was reviewed by Anders Peter Adamsen, Aarhus University, DCA – National Centre for Food and Agriculture. The reviewer have reviewed all sections of the report.

5.13.3 QA/QC plan expressed in Critical Control Points and Point of Measurements

Data storage level 1

Data Storage level 1	3. Completeness	DS.1.3.1	Documentation showing that all possible national data sources are included by setting down the reasoning behind the selection of datasets.
----------------------	-----------------	----------	--

The following external data are in used in the agricultural sector, in more details see Table 5.3:

- Data from the annual agricultural census made by Statistics Denmark.

- DCA, Aarhus University.
- The Danish Agricultural Agency
- SEGES
- The Danish Energy Agency.
- Danish Environmental Protection Agency.

The emission factors come from various sources:

- IPCC guidelines.
- DCA, Aarhus University: NH₃ emission, CH₄ emission from enteric fermentation and manure management.

Statistics Denmark

The agricultural census made by Statistics Denmark is the main supply of basic agricultural data. In Denmark, all cattle, sheep and goats have to be registered individually and hence the uncertainty in the data is negligible. For all other animal types, farms having more than 10 animal units are registered.

DCA

The DCA is responsible for the delivery of N-excretion data for all animal and housing types. Data on feeding consumption on commercial farms are collected annually by SEGES from on-farm efficacy controls. For dairy cattle, data is collected from 15-20 % of all farms, for pigs, 25-30 % and for poultry and mink, 90-100 % of all farms. The farm data are used to calculate average N-excretion from different animal and housing types. Due to the large amount of farm data involved in the dataset, N-excretion is seen as a very good estimate for average N-excretion at the Danish livestock production.

Danish Agricultural Agency

Total area with the various agricultural crops is provided to the Danish Agricultural Agency via the agricultural subsidy system. For every parcel of land (via a vector-based field map with a resolution of >0.01 ha), the area planted with different crops is reported. If the total crop area within a parcel is larger than the parcel area, a manual control of the information is performed by the Agency. The area with different crops, therefore, represents a very precise estimate.

All farmers are obligated to do N-fertiliser accounting on a farm and field level based on the Danish normative data provided by DCA. Data at farm level is reported annually to the Danish Agricultural Agency. The N figures also include the quantities of inorganic N fertilisers applied to agricultural soils. Suppliers of inorganic N fertilisers are required to report all N sales to commercial farmers to the Danish Agricultural Agency, which is registered and published in a sales statistic annually. Comparison between the sales statistics and the N fertiliser account, shows a higher consumption of N in inorganic fertilisers from 2005, which is caused by an import from the farmers themselves. Therefore, the consumption of N in use of inorganic fertiliser registered in the N fertiliser account seems to be the most reliable reference.

The Danish Agricultural Agency, as the controlling authority, performs analysis of feed sold to farmers. On average, 1600 to 2000 samples are analysed every year. Uncertainty in the data is seen as negligible. The data are used when estimating average energy in feedstuffs for pigs, poultry, fur animals, etc.

From 2005, the Danish Agricultural Agency provides data for distribution of housing type based on registration from farmers to the Danish fertiliser N accounts.

SEGES

SEGES is the central office for all Danish agricultural advisory services. SEGES carries out a considerable amount of research itself, as well as collecting efficacy reports from the Danish farmers for dairy production, meat production, pig production, etc., to optimise productivity in Danish agriculture. From SEGES data on housing type until 2004, grazing situation and information on application of manure is received.

The Danish Energy Agency

The amount of slurry treated in biogas plants is received from the Danish Energy Agency.

Danish Environmental Protection Agency

Information on the sludge from wastewater treatment and the manufacturing industry and the amount applied on agricultural soil is obtained from the Danish Environmental Protection Agency.

Data Storage level 1	1. Accuracy	DS.1.1.1	General level of uncertainty for every dataset including the reasoning for the specific values
----------------------	-------------	----------	--

The most important emission source is related to the animal production. Uncertainty for the animal data is very low due to the very strict environmental laws in Denmark. Standard deviation regarding the numbers of cattle and pigs has been estimated to <0.7 %. For poultry the standard deviation is <2.1 %. For all years, 25-35 % of all holdings are included in the census. The standard deviation for N-excretion between farms is reported as 25 % for dairy cattle and pigs, but due to the large numbers involved in the estimation of the average N-excretion, the average is assumed a precise estimate for the Danish agricultural efficacy level.

Regarding uncertainties for the remaining emission sources, see Chapter 5.12.

Data Storage level 1	1. Accuracy	DS.1.1.2	Quantification of the uncertainty level of every single data value including the reasoning for the specific values.
----------------------	-------------	----------	---

Please, refer to Chapter 5.12 and Table 5.31.

Data Storage level 1	1. Comparability	DS.1.2.1	Comparability of the data values with similar data from other countries, which are comparable with Denmark, and evaluation of discrepancy.
----------------------	------------------	----------	--

The Danish N-excretion levels are generally lower than IPCC default values. This is due to the highly skilled, professional and trained farmers in Denmark, with access to a highly competent advisory system.

The feed consumption per animal is in line with similar data from Sweden, although they are not quite comparable because Denmark is using feeding units (FE) which cannot easily be converted to energy content. Earlier, one

feeding unit was defined as one kg of barley. Today, the calculations are more complicated and depend on animal type.

Data Storage level 1	4. Consistency	DS.1.4.1	The origin of external data has to be preserved whenever possible without explicit arguments (referring to other PMS).
----------------------	----------------	----------	--

External data received are stored in the original format in the quality management database system.

Data Storage level 1	6. Robustness	DS.1.6.1	Explicit agreements between the external institution holding the data and DCE about the conditions of delivery.
----------------------	---------------	----------	---

DCE has established formal data agreements with all institutes and organisations, which deliver data, to assure that the necessary data is available to prepare the inventory on time.

Data Storage level 1	6. Robustness	DS.1.6.2	At least two employees must have a detailed insight into the gathering of every external data set.
----------------------	---------------	----------	--

Please refer to Chapter 1.6.

Data Storage level 1	7. Transparency	DS.1.7.1	Summary of each dataset including the reasoning for selecting the specific dataset.
----------------------	-----------------	----------	---

Please refer to DS 1.1.1.

Data Storage level 1	7. Transparency	DS.1.7.2	The archiving of data sets needs to be easy accessible for any person in the emission inventory.
----------------------	-----------------	----------	--

Please refer to Chapter 1.6.

Data Storage level 1	7. Transparency	DS.1.7.3	References for citation for any external data set have to be available for any single value in any dataset.
----------------------	-----------------	----------	---

A great deal of documentation already exists in the literature list, and is also achieved in the quality management database system.

Data Storage level 1	7. Transparency	DS.1.7.4	Listing of external contacts for every dataset.
----------------------	-----------------	----------	---

Statistics Denmark:

Mrs. Mona Larsen (mla@dst.dk)

Mr. Karsten K. Larsen (kkk@dst.dk)

DCA (Aarhus University):

Mr. Christian Friis Børsting (cfb@anis.au.dk)

Mr. Peter Lund (peter.lund@anis.au.dk)

Mr. Christen Duus Børgesen (christen.Borgesen@agro.au.dk)

Mrs. Gitte Blicher-Mathisen (gbm@bios.au.dk)

Mr. Henrik Tornbjerg (hto@bios.au.dk)

SEGES:

Mr. Torkild Birkmose (tsb@seges.dk)

Danish Agricultural Agency:

Mrs. Mette Skade (mail@lbst.dk)

The Danish Energy Agency:

Mr. Søren Tafdrup (st@ens.dk)

Data processing level 1

Data Processing level 1	1. Accuracy	DP.1.1.1	Uncertainty assessment for every data source as input to Data Storage level 2 in relation to type of variability. (Distribution as: normal, log normal or other type of variability).
-------------------------	-------------	----------	---

The Approach 1 methodology is used to calculate the uncertainties for the agricultural sector. The uncertainties are based on a combination of IPCC guidelines and expert judgement (Olesen et al., 2001, Poulsen et al., 2001) and a normal distribution is assumed.

Data Processing level 1	1. Accuracy	DP.1.1.2	Uncertainty assessment for every data source as input to Data Storage level 2 in relation to scale of variability (size of variation intervals).
-------------------------	-------------	----------	--

Please refer to DP 1.1.1.

Data Processing level 1	1. Accuracy	DP.1.1.3	Evaluation of the methodological approach using international guidelines.
-------------------------	-------------	----------	---

Denmark has worked out a report with a more detailed description of the methodological inventory approach in Mikkelsen et al. (2006), Mikkelsen et al. (2011), Mikkelsen et al. (2014), Albrektsen et al. (2017) and an updated version in Albrektsen et al. (2021). The first report has been reviewed by the Statistics Sweden, who is responsible for the Swedish agricultural inventory; the second was reviewed of qualified persons with comprehensive agricultural knowledge; Nicholas J. Hutchings from the DCA, Aarhus University and Johnny M. Andersen from the Faculty of Life Sciences, University of Copenhagen. The third was reviewed by MST. The fourth was reviewed by Peter Lund, from Department of Animal Science, Aarhus University and the latest was reviewed by Anders Peter Adamsen, Aarhus University, DCA – National Centre for Food and Agriculture. None of the reviewers is involved in the preparation of the annual inventory.

Furthermore, data sources and calculation methodology developments are continuously discussed in cooperation with specialists and researchers in different institutes and research sections. Consequently, both the data and methods are evaluated continually according to the latest knowledge and information.

Data Processing level 1	1. Accuracy	DP.1.1.4	Verification of calculation results using guideline values
-------------------------	-------------	----------	--

The methodological approach is consistent with the IPCC 2006 Guidelines. See Chapter 5.13.1.

Data Processing level 1	2. Comparability	DP.1.2.1	The inventory calculation has to follow the international guidelines suggested by UN-FCCC and IPCC.
-------------------------	------------------	----------	---

The methodological approach is consistent with the IPCC 2006 Guidelines.

Data Processing level 1	3. Completeness	DP.1.3.1	Assessment of the most important quantitative knowledge, which is lacking.
-------------------------	-----------------	----------	--

Regarding the reduction potential for biogas treated slurry, more information and investigation would be preferred. There is on-going work to increase the accuracy of this emission source.

Data Processing level 1	3. Completeness	DP.1.3.2	Assessment of the most important missing accessibility to critical data sources
-------------------------	-----------------	----------	---

All known major sources are included in the inventory. In Denmark, only very few data are restricted. Accessibility is not a key issue; it is more lack of data.

Data Processing level 1	4. Consistency	DP.1.4.1	In order to keep consistency at a high level, an explicit description of the activities needs to accompany any change in the calculation procedure
-------------------------	----------------	----------	--

The calculation procedure is consistent for all years.

Data Processing level 1	4. Consistency	DP.1.4.2	Identification of parameters (e.g. activity data, constants) that are common to multiple source categories and confirmation that there is consistency in the values used for these parameters in the emission calculations
-------------------------	----------------	----------	--

Please refer to Chapter 1.6.

Data Processing level 1	5. Correctness	DP.1.5.1	Show at least once, by independent calculation, the correctness of every data manipulation.
-------------------------	----------------	----------	---

During the development of the model, thorough checks have been made by all persons involved in preparation of the agricultural section.

Data Processing level 1	5. Correctness	DP.1.5.2	Verification of calculation results using time series.
-------------------------	----------------	----------	--

Time series for activity data, emission factors and national emission are performed to check consistency in the methodology, to avoid errors, to identify and explain considerable year-to-year variations.

Data Processing level 1	5. Correctness	DP.1.5.3	Verification of calculation results using other measures.
-------------------------	----------------	----------	---

A comparison between IPCC Tier 2 method for enteric fermentation and Denmark's Tier 2/CS is made, see Chapter 5.13.1.

Data Processing level 1	5. Correctness	DP.1.5.4	Show one-to-one correctness between external data sources and the databases at Data Storage level 2
-------------------------	----------------	----------	---

In the database key ids is used to identify the unique data. The data on DS level 1 is linked to the key id used in the database so a clear reference from DS level 1 to higher levels of both DP and DS is secured.

Data Processing level 1	6. Robustness	DP.1.6.1	Any calculation must be anchored to two responsible persons that can replace each other in the technical issue of performing the calculations.
-------------------------	---------------	----------	--

Please refer to Chapter 1.6.

Data Processing level 1	7. Transparency	DP.1.7.1	The calculation principle and equations used must be described.
-------------------------	-----------------	----------	---

All calculation principles are described in the NIR and the documentation report (Albrektsen et al., 2021).

Data Processing level 1	7. Transparency	DP.1.7.2	The theoretical reasoning for all methods must be described.
-------------------------	-----------------	----------	--

All theoretical reasoning is described in the NIR and the documentation report (Albrektsen et al., 2021).

Data Processing level 1	7. Transparency	DP.1.7.3	Explicit listing of assumptions behind methods.
-------------------------	-----------------	----------	---

All theoretical reasoning is described in the NIR and the documentation report (Albrektsen et al., 2021).

Data Processing level 1	7. Transparency	DP.1.7.4	Clear reference to dataset at Data Storage level 1.
-------------------------	-----------------	----------	---

In the database key ids is used to identify the unique data. The data on DS level 1 is linked to the key id used in the database so a clear reference from DS level 1 to higher levels of both DP and DS is secured.

Data Processing level 1	7. Transparency	DP.1.7.5	A manual log to collect information about recalculations.
-------------------------	-----------------	----------	---

Changes compared with the last emissions report are described in the NIR and the national emission changes is given in a table under the section, "Recalculation". The text describes whether the change is caused by changes in the dataset or changes in the methodology used. Furthermore, a log table is filled in when data are updated or adjusted continuously.

Data storage and processing level 2

For point of measurements not mentioned below, please refer to Chapter 1.6.

Data Storage level 2	5. Correctness	DS.2.5.1	Documentation of a correct connection between all data types at level 2 to data at level 1.
----------------------	----------------	----------	---

A manual checklist is under development for correct connection between all data types at level 1 and 2.

Data Processing level 2	5. Correctness	DS.2.5.2	Check if a correct data import to level 2 has been made.
-------------------------	----------------	----------	--

A manual checklist is under development for correctness of data import to level 2.

5.14 Recalculations

Below an overview of improvements and recalculations implemented since the 2021 submission.

A range of changes in calculation of agricultural emissions 1990-2019 has taken place. The recalculation has contributed to an increase in the total agricultural emissions for the years 1990-2019 of 2-3 % and given in CO₂ equivalent (Table 5.39).

Table 5.39 Changes in GHG emission in the agricultural sector compared with the CRF reported last year.

	1990	1995	2000	2005	2010	2015	2018	2019
Previous inventory								
3.A Ent. Ferm., kt CH ₄	161.6	158.7	145.2	139.3	145.2	146.7	150.7	148.8
3.B Man. Man., kt CH ₄	74.1	85.6	94.8	100.5	93.3	88.9	88.5	84.7
3.B Man. Man., kt N ₂ O	3.2	3.1	3.1	3.2	2.6	2.4	2.4	2.2
3.D Agri. Soils, kt N ₂ O	18.8	16.4	14.7	13.5	13.2	13.4	13.2	14.1
3.Da1 Inorganic N fertilizer	6.3	5.0	4.0	3.2	3.1	3.3	3.5	3.7
3.Da2a Animal manure	3.3	3.1	3.1	3.3	3.3	3.3	3.4	3.3
3.Da2b Sewage sludge	0.05	0.07	0.06	0.04	0.06	0.06	0.05	0.06
3.Da2c Other organic	0.02	0.07	0.08	0.04	0.05	0.07	0.08	0.09
3.Da3 Grazing animals	1.0	1.0	1.0	0.7	0.6	0.6	0.6	0.6
3.Da4 Crop residues	1.9	1.8	1.8	2.0	2.1	2.2	1.6	2.3
3.Da5 Mineralization	0.6	0.3	0.2	0.1	0.1	0.1	0.4	0.2
3.Da6 Organic soils	2.7	2.6	2.5	2.4	2.2	2.1	2.0	2.0
3.Db1 Atmo. Depo.	1.1	0.9	0.7	0.6	0.5	0.5	0.6	0.6
3.Db2 Nitrogen leaching	1.8	1.6	1.4	1.1	1.1	1.2	1.0	1.2
3.F Field Burning, kt CH ₄	0.1	0.1	0.1	0.1	0.1	0.1	0.1	0.2
3.F Field Burning, kt N ₂ O	0.002	0.003	0.003	0.004	0.003	0.003	0.004	0.004
3.G Liming, kt CO ₂	565.5	496.0	260.6	219.7	152.8	165.6	239.9	181.4
3.H-I Urea and CAN, kt CO ₂	53.1	41.1	7.8	2.1	3.4	11.9	4.3	3.8
Total in CO ₂ eqv., M. t	13.09	12.46	11.60	11.19	10.83	10.79	10.88	10.90
Current inventory								
3.A Ent. Ferm., kt CH ₄	161.6	158.7	145.2	139.3	145.2	146.7	149.8	147.8
3.B Man. Man., kt CH ₄	74.2	85.8	95.1	100.9	93.6	89.2	89.5	85.9
3.B Man. Man., kt N ₂ O	3.2	3.1	3.2	3.2	2.6	2.4	2.5	2.3
3.D Agri. Soils, kt N ₂ O	19.7	17.3	15.6	14.3	14.0	14.4	14.1	15.0
3.Da1 Inorganic N fertilizer	6.3	5.0	4.0	3.2	3.1	3.3	3.5	3.7
3.Da2a Animal manure	3.3	3.1	3.1	3.3	3.3	3.3	3.4	3.3
3.Da2b Sewage sludge	0.05	0.07	0.06	0.04	0.06	0.06	0.05	0.07
3.Da2c Other organic	0.02	0.07	0.08	0.04	0.05	0.07	0.08	0.09
3.Da3 Grazing animals	1.0	1.0	1.0	0.7	0.6	0.6	0.6	0.6
3.Da4 Crop residues	2.5	2.3	2.5	2.6	2.8	3.1	2.3	3.2
3.Da5 Mineralization	0.7	0.4	0.4	0.2	0.1	0.1	0.4	0.3
3.Da6 Organic soils	2.7	2.6	2.5	2.4	2.2	2.1	2.0	2.0
3.Db1 Atmo. Depo.	1.3	1.0	0.8	0.6	0.6	0.6	0.6	0.6
3.Db2 Nitrogen leaching	1.8	1.7	1.4	1.1	1.1	1.2	1.1	1.2
3.F Field Burning, kt CH ₄	0.1	0.1	0.1	0.1	0.1	0.1	0.1	0.2
3.F Field Burning, kt N ₂ O	0.002	0.003	0.003	0.004	0.003	0.003	0.004	0.004
3.G Liming, kt CO ₂	565.5	496.0	260.6	219.7	152.8	165.6	239.9	181.4
3.H-I Urea and CAN, kt CO ₂	48.0	37.6	7.0	1.9	3.1	10.5	3.9	3.3
Total in CO ₂ -eqv., M. t	13.34	12.72	11.87	11.44	11.07	11.09	11.15	11.18
Change								
3.A Ent. Ferm., kt CH ₄	0	0	0	0	0	0	-0.908	-0.94
3.B Man. Man., kt CH ₄	0.09	0.22	0.32	0.39	0.30	0.31	1.00	1.23
3.B Man. Man., kt N ₂ O	0.001	0.01	0.02	0.02	0.01	0.01	0.06	0.07
3.D Agri. Soils, kt N ₂ O	0.85	0.84	0.86	0.79	0.79	0.97	0.85	0.86
3.Da1 Inorganic N fertilizer	0	0	0	0	0	0	0	-0.05
3.Da2a Animal manure	0	0	0	0.002	0.002	0.005	0.005	0
3.Da2b Sewage sludge	0	0	0	0	0	0	0	0.01
3.Da2c Other organic	0.0000005	0.000001	0.000002	0.000002	0.000003	0.000004	0.000009	0.00001
3.Da3 Grazing animals	0	0	0	0	0	0	0	0
3.Da4 Crop residues	0.55	0.57	0.64	0.64	0.65	0.84	0.69	0.83
3.Da5 Mineralization	0.12	0.14	0.13	0.09	0.06	0.05	0.08	0.10

3.Da6 Organic soils	0	0	0	0	0	0.0003	0.0003	0.0003
3.Db1 Atmo. Depo.	0.14	0.11	0.09	0.05	0.05	0.05	0.04	0.00
3.Db2 Nitrogen leaching	0.03	0.01	0.00	0.01	0.03	0.02	0.04	-0.03
3.F Field Burning, kt CH ₄	0	0	0	0	0	0.002	0.0001	-0.001
3.F Field Burning, kt N ₂ O	0	0	0	0	0	0.00004	0.000004	-0.00002
3.G Liming, kt CO ₂	0	0	0	0	0	0	0	0
3.H-I Urea and CAN, kt CO ₂	-5.1	-3.5	-0.7	-0.2	-0.3	-1.4	-0.4	-0.5
Total in CO ₂ -eqv., M. t	0.25	0.25	0.27	0.25	0.24	0.30	0.27	0.28
Change in pct.								
3.A Ent. Ferm., kt CH ₄	0	0	0	0	0	0	-0.60	-0.63
3.B Man. Man., kt CH ₄	0.12	0.26	0.34	0.39	0.32	0.35	1.13	1.45
3.B Man. Man., kt N ₂ O	0.04	0.38	0.74	0.47	0.33	0.51	2.39	3.24
3.D Agri. Soils, kt N ₂ O	4.49	5.09	5.81	5.83	5.97	7.21	6.45	6.10
3.Da1 Inorganic N fertilizer	0	0	0	0	0	0	0	-1.24
3.Da2a Animal manure	0	0	0	0.05	0.07	0.17	0.14	0.05
3.Da2b Sewage sludge	0	0	0	0	0	0	0	13.80
3.Da2c Other organic	0.002	0.001	0.002	0.01	0.01	0.01	0.01	0.01
3.Da3 Grazing animals	0	0	0	0	0	0	0	0
3.Da4 Crop residues	28.74	32.47	34.95	32.43	30.43	37.72	43.34	35.85
3.Da5 Mineralization	22.35	48.54	59.33	64.99	86.42	77.56	21.44	46.87
3.Da6 Organic soils	0	0	0	0	0	0.01	0.01	0.01
3.Db1 Atmo. Depo.	12.72	13.01	12.58	8.11	9.14	8.66	7.12	0.23
3.Db2 Nitrogen leaching	1.71	0.76	0.00	0.71	2.87	1.88	4.19	-2.72
3.F Field Burning, kt CH ₄	0	0	0	0	0	1.4	0.1	-0.4
3.F Field Burning, kt N ₂ O	0	0	0	0	0	1.4	0.1	-0.4
3.G Liming, kt CO ₂	0	0	0	0	0	0	0	0
3.H-I Urea and CAN, kt CO ₂	-9.6	-8.4	-9.3	-10.6	-9.9	-11.8	-9.0	-13.2
Total in pct.	1.91	2.04	2.32	2.22	2.26	2.76	2.51	2.61

The most significant inventory changes are mentioned below.

5.14.1 Enteric fermentation

A decrease of 0.60 % and 0.63 % are seen for the years 2018 and 2019, respectively. The main reason for the recalculation is change in the national Y_m for dairy cattle. Lund et al (2020) has estimated Y_m for large breed and jersey dairy cattle for 2018 and this has been used for the calculations of enteric fermentation from dairy cattle for 2018 and 2019.

Number of weaners and fattening pigs has been recalculated for 2018 and 2019 due to updated data from Statistics Denmark.

5.14.2 Manure management

Recalculations have been made for CH₄, N₂O, NO_x and NMVOC.

CH₄

Changes have been made in configuration of the model IDA so emissions from biogas treated slurry is included in a more suitable constellation. This gives changes in the distribution on manure management systems. Further more updated data from the BIB – register (Biomass Input to Biogas production) for the years 2015-2019 have been received from the Danish Energy Agency.

Both updates affects the estimation of MCF from biogas treated slurry. This changes the emission of CH₄ from manure management with less than 1 % for the years 1990-2015 and with 1-1.5 % for the years 2016-2019.

For the number of animals some changes has been made; number of weaners and fattening pigs has been recalculated for 2018 and 2019 due to updated data from Statistics Denmark. The distribution between male and female turkeys has been changed for the years 2005-2019. Before the distribution was 50/50 male/female for all years 1990-2019 based on expert judgement, but numbers from the farmers' registration of housing type from the Danish Agricultural Agency (available from 2005) shows a different distribution and this has now been taken into account. These changes gives small changes in the emission of CH₄ from manure management.

N₂O

The changes in the configuration of the model IDA mentioned above gives changes in both direct and indirect emission of N₂O from manure management. It increases the emission of direct emission, while the emission of indirect emission is decreased due to a combination of the changes manure management systems and changes in the NH₃ emission calculations. The NH₃ emission from manure management is changed due to changes in EF and distribution of NH₃ reducing technology.

Furthermore, updated data from the BIB – register (Biomass Input to Biogas production) for the years 2015-2019 have been received from the Danish Energy Agency.

The overall changes shows an increases the emission of N₂O from manure management with less than 1 % for the years 1990-2015 and an increase of 2-3 % for the years 2016-2019.

Changes in number of animals as mentioned above gives small changes in the emission of N₂O from manure management.

NMVOC

For 1990-2002, the emission of NMVOC from manure management is changed due to an error in the calculation for heifers, which overestimated the amount of VS in calculation of NMVOC.

Changes in the proportion of emissions of NH₃ from housing and storage also affect the calculation of NMVOC.

These changes decreases the emission for years 1990-2002 with 10-11 %. For the years 2003-2019, the emission changes less than 0.05 %.

NO_x

Changes in distribution between male and female turkeys mentioned above are the main reason for change in the NO_x emissions for 2005-2019, the recalculation changes in the emission with less than 0.2 % for all years.

5.14.3 Agricultural soils

Recalculation of N₂O emission from agricultural soils increases the overall emission for all the years 1990-2018 with 4-7 %. The emission of NMVOC and NO_x has also been recalculated. Changes for all subcategories a mentioned below.

3Da1 Inorganic fertiliser: Emission of N₂O and NO_x from inorganic fertiliser for 2019 was, in submission 2021, based on an unpublished version of the sales statistics, because this was the only data available. The sales statistics has now been updated and published (DAA, 2021). Based on the new data in the updated sales statistic for inorganic fertiliser for 2019, the emission of N₂O and NO_x decreases for 2019 with 1.2 %.

3Da2a Animal manure applied to soil: Emission of N₂O and NO_x increases with less than 0.2 % for the years 2005-2019 and this is due to changes in the allocation of NH₃ reducing technology, where the emission of NH₃ from housing decreases and the amount of N in manure for application thereby increases.

Emission of NMVOC from manure applied to soil increases with 20-33 % for all years 1990-2019. This is due to update of NH₃ EF for manure applied to soil because the calculation of emission of NMVOC from manure applied to soil is depending on the proportion of emissions of NH₃ from housing and application. NH₃ EF for manure applied is updated based on Hafner et al. (2021).

3Da2b Sewage sludge applied to soil: A recalculation of N₂O and NO_x is made for 2019 due to updated values from statistics. In submission 2021, no statistic were available for the amount of N from sewage sludge for 2019 and the amount was therefore based on an average of previous years. The statistic is now available (Madsen et al., 2020). This increase the emission with 14 %.

3Da2c Other organic fertilizer applied to soil: Small recalculations of N₂O and NO_x is made for all years 1990-2019, which changes the emission with less than 0.01 %. The change is due to updated data from the BIB – register (Biomass Input to Biogas production) for the years 2015-2019 received from the Danish Energy Agency. The updated data changes the amount of N in biomass other than manure treated in biogas plants.

No recalculations of emission from sludge from industries.

3Da3 Urine and dung deposited by grazing animals: For N₂O no recalculation.

NMVOC emission are recalculated for the years 1990-2002 due to an error in the calculation for heifers, which overestimated the amount of VS. This decreases the emission for years 1990-2002 with 10-11 %.

3Da4 Crop residues: Changes in the calculation of N content in crop residue has taken place this year, which all leads to higher N content. The three most important changes are mentioned below.

During 2021, an intern review of calculation of N₂O from crop residue was provided, and it became clear that the estimate for the N content was too low. The calculation of N content in crop residues below ground, both dry matter quantity from harvested crops and dry matter quantity in crop residue above ground had to be included. So far, the calculation is based only on dry matter in harvested crops. The adjusted calculation leads to a higher total N content for all crop types.

Furthermore, the calculation for “perennial grasses” has been adjusted. So far, no harvest product has been registered, and thus the calculation leads to no N content in crop residue. However, even when no harvest takes place, there

will still be an N-turnover process taking place. Therefore, in this year's calculation, an estimate for harvest product by half of the crop "grass-clover mixtures, outside rotation" is assumed.

The last adjustment to be mentioned is that the calculation now takes the N content from catch crops into account. The use of catch crop is increasing, because this is an important measure to avoid or reduce the N surplus leaching to the aquatic environment. The catch crop area has increased from approximately 200,000 hectare in 2010 to 500,000 hectare in 2020.

The emission of N₂O from crop residue has increased with 29-43 % for the years 1990-2019.

3Da5 Mineralization: A recalculation has been made for the whole time series for N₂O emission from agricultural mineral soils due to a change of a parameter in C-TOOL. For winter wheat, the input of carbon to the soil has been decreased for all years as the share of straw in relation to kernel yield were found too high. As the annual carbon input in the modelling to the agricultural soil has decreased for all years, a larger decrease in the soil carbon stock is modelled and consequently a higher loss of N from the organic soil carbon stock occurs. Therefore, the emission of N₂O from agricultural mineral soils increases with 22-110 % for the years 1990-2019.

3Da6 Cultivation of organic soils: N₂O emissions from organic soils is changed for the years 2012-2019. In submission 2021, area of organic soils were recalculated in the LULUCF sector and also updated in the agricultural sector, except for the area of shallow drained, nutrient-rich grassland, which due to an error were not updated in the agricultural sector. This have been corrected in this submission (2022). The emission of N₂O from organic soils is increased with 0.01 % for the years 2012-2019.

3Db1 Atmospheric deposition: Emission of N₂O from atmospheric deposition has been recalculated for all years 1990-2019 mainly due to updated emission of NH₃ from manure applied to soil, but in 2019 also due to updated data for inorganic fertiliser. NH₃ EF for manure applied is updated based on Hafner et al. (2021), which increases the emission of NH₃ from manure applied to soil. The emission from of N₂O from atmospheric deposition has increased with 7-14 % in the years 1990-2018, but for 2019 the emission of N₂O only increase 0.2 % and this is because the increase of NH₃ from manure applied to soil and the decrease in NH₃ from inorganic fertiliser almost even out the change in NH₃ emission.

3Db2 Nitrogen leaching and run-off: Emission of N₂O from leaching has been recalculated, which can be explained by two reasons. The first one have to do with changes of the amount of N applied to agricultural soils, which is mentioned above (inorganic/organic fertiliser and pasture). The second one is due to updated data for N-leaching to rivers and estuaries, which is based on data received from the Department of Ecoscience, Aarhus University, provided in relation to the national monitoring program (NOVANA). This year, a larger update for all years 1990-2018 has been provided and the Department of Ecoscience mention three main reasons for this update. 1) the Danish Meteorological Institute has updated to low rainfall from 2011 and forwards, which is now corrected, 2) Correction of total N content in laboratory measurements, 3) Updated map for the 3351 Danish catchment areas (in average 15 km² per unit).

The emission changes up to 4 % for the years 1990-2019.

5.14.4 Field burning of agricultural residue

Recalculations have been made for the years 2015-2019 due to updated data from Statistics Denmark on the amount of harvested straw. This changes the emission of CH₄, N₂O, NO_x and NMVOC with up to 1.5 %.

5.14.5 Liming

No recalculations.

5.14.6 Urea and other C-containing fertilisers

Recalculations has been made for the CO₂ emissions from urea and C-containing fertilisers because the Danish Agricultural Agency has published an updated version of the sales statistics for inorganic fertiliser for 2019. The emission from urea decreases 0.1 % for 2019. Furthermore, the emission factor for C-containing fertiliser has been corrected. Due to an error, the emission factor was rounded to 0.03 and this is now corrected to 0.026. This decreases the emission of CO₂ from C-containing fertiliser with 13 % for the years 1990-2018. In 2019, the emission from C-containing fertiliser decreases 16 % due both updated data from the sales statistic and corrected emission factor.

5.15 Category-specific improvements

5.15.1 Response to the review process

A review of the Danish 2021 submission took place in September 2021. At the time of preparing this report, Denmark had not yet received a draft review report. Therefore, the table below represents the latest available report.

Table 5.40 Response to the review process.

Para.	CRF	ERT Comment	Denmark's response	Reference
2020 submission (Review report: https://unfccc.int/sites/default/files/resource/arr2020_DNK.pdf)				
A.5	3.A.1 Cattle – CH ₄	<p>The Party reported in its NIR (section 5.3.2, p.383) information on country-specific values of Y_m, which were developed on the basis of the Karoline model and new measurements from a publication (Hellwing et al., 2014).</p> <p>The ERT recommends that the Party include information on the planned revisions for the Karoline model in its description of planned improvements in the NIR</p>	<p>The model Karoline has been revised and are not called Karoline any more. Never the less the model estimating the national Y_m for dairy cattle has been updated and Y_m has been recalculated for 2018 and 2019.</p> <p>The reference Hellwing et al., (2014) has been updated to Hellwing et al., (2016)</p> <p>The estimation of Y_m is an ongoing work as feeding practices relevant to the model (e.g. future changes expected from the use of feed additives for reducing enteric CH₄, which are to be commercially available within the next few years) changes will be taken into account when revising the model, as necessary.</p>	<p>Chapter 5.3, Methane conversion rate (Y_m)</p> <p>Chapter 5.16</p>
A.6	3.B Manure management – N ₂ O	<p>The Party reported in its NIR (section 5.13, p.412) a comparison between the total Nex estimated by DCE and DCA as part of the QA/QC procedures (stage IV). Although there was a brief explanation of the impact of the use of different animal categories and grazing definitions by DCE and DCA, the NIR did not contain information on potential differences between the estimation methods.</p> <p>The ERT recommends that the Party include in the list of planned improvements in the NIR updated information on the verification of total Nex used in the inventory calculations, including its plan to compare it with farmers' N accounts.</p>	<p>Information on the planned work with comparison between Nex estimated by DCE and DCA are included in Chapter 5.16 Planned improvements</p>	Chapter 5.16
A.7	3.D Direct and indirect N ₂ O emissions from agricultural soils – N ₂ O	<p>The Party reported in its NIR (section 5.14, p.423) information on recalculations performed for the agriculture sector. Although several improvements or changes have been implemented for several subcategories of agricultural soils, the Party did not estimate the impact of the recalculations on emissions for each subcategory.</p> <p>The ERT encourages the Party to include in the NIR the estimated impact of recalculations on emissions for each subcategory and the contribution of the changes under each subcategory to the overall change in the category (percentage), in line with the information provided to the ERT during the review.</p>	<p>The Table in Chapter 5.14 has been extended to include the subcategories of sector 3D Agricultural soils.</p>	Chapter 5.14, Table 5.39

5.16 Planned improvements

Caused by the requirements to continued focus on the possibilities to reduce the agricultural ammonia emission, a still increasing part of the farmers choose ammonia reducing technologies as for example air scrubbers, slurry acidification and slurry cooling, where the last two technologies mention also leads to a reduction in CH₄ emission. However, reduction of CH₄ are not yet included due to lack of verified reduction potential. Ammonia reduction from air scrubbers are not yet included either. However, a further work is ongoing to include effect of reduced CH₄ in the future emission inventories, as well as the ammonia reduction from air scrubbers.

The national Y_m factor for dairy cattle has been updated this year due change in the fodder practice. However, a lot of scientific work is still going on about new feeding strategies with e.g. supply of fatty acids and other feed additives to reduce the CH_4 emission from enteric fermentation. This work will be followed and included in the inventory when it is implemented by farmers in Danish cattle production.

The Danish normative system for N-excretion and NH_3 emission is planned to be extended to also include carbon and CH_4 emission, by means of a range of scientific projects covering methane emission from livestock, housing and storage facilities. This work is planned for the years 2021-2024. When results are available, they will be incorporated in the Danish emission inventory as far as possible.

5.17 References

Aaes, Ole, 2008: Personal communication. Knowledge Centre for Agriculture (now SEGES).

Aaes, Ole, 2016: Personal communication, data received. SEGES.

Albrektsen, R., Mikkelsen, M.H. & Gyldenkærne, S. 2017: Danish emission inventories for agriculture. Inventories 1985 – 2015. Aarhus University, DCE – Danish Centre for Environment and Energy, 190 pp. Scientific Report from DCE – Danish Centre for Environment and Energy No. 250. Available at: <http://dce2.au.dk/pub/SR250.pdf> (Jan. 2022).

Albrektsen, R., Mikkelsen, M.H. & Gyldenkærne, S. 2021. Danish emission inventories for agriculture. Inventories 1985 – 2018. Aarhus University, DCE – Danish Centre for Environment and Energy, 202 pp. Scientific Report No. 443. Available at: <http://dce2.au.dk/pub/SR443.pdf> (Jan. 2022).

Andersen, L., 2004: Personal Communications. Lars Andersen, Kalklejer, Vildmosevej 13, 9293 Kongerslev, Tlf.: 98 33 13 77, d. 14. nov. 2004.

Andreae, M.O. & Merlet, P., 2001: Emission of trace gases and aerosols from biomass burning. *Global Biogeochemical Cycles*, vol. 15, no. 4, pages 955-966, Dec. 2001.

Blicher-Mathiesen, G., Rasmussen, A., Rolighed, J., Andersen, H.E., Carstensen, M.V., Jensen, P.G., Wienke, J., Hansen, B. & Thorling, L. 2018: Landovervågningsoplande 2016. NOVANA. Aarhus Universitet, DCE – Nationalt Center for Miljø og Energi, 192 s. - Videnskabelig rapport fra DCE - Nationalt Center for Miljø og Energi nr. 273 (In Danish). Available at: <http://dce2.au.dk/pub/SR273.pdf> (Feb. 2022).

Børgesen, C.D. & Grant, R. 2003: Vandmiljøplan II – modelberegning af kvælstofudvaskning på landsplan, 1984 til 2002. Baggrundsnotat til Vandmiljøplan II - slutevaluering. December 2003, Danmarks Jordbrugsforskning og Danmarks Miljøundersøgelser. (In Danish).

Børsting, C.F., Hellwing, A.L.F. & Lund, P., 2021: Normative figures 2021. DCA - Danish Centre for Food and Agriculture, Aarhus University. Available at: <http://anis.au.dk/forskning/sektioner/husdyrernaering-og-fysiologi/normtal/> (Jan. 2022).

Clausen, Eric F., 2008: Personal communication. Knowledge Centre for Agriculture (now SEGES).

Clausen, E., 2020: Number of horses in Denmark in 2019, received per mail 22.09.2020, from Eric Clausen, SEGES.

Crutzen, P.J., Aselmann, I. & Seiler, W., 1986: Methane Production by Domestic Animals, Wild Ruminants, Other Herbivorous Fauna, and Humans. *Tellus* 38B:271-284.

Danish Agricultural Agency, 2021: Inorganic N fertiliser sold in Denmark 2018/2019 and 2019/2020. (in Danish). Available at: https://lbst.dk/fileadmin/user_upload/NaturErhverv/Filer/Virksomheder/Handelsgoedning/Statistik_salg_af_handelsgoedning/Rapport_over_solgt_goedning_for_18-19_og_19-20_01.pdf (Dec. 2021).

Danish Energy Agency (DEA), 2009: Spildevandsslam fra kommunale og private renselanlæg i 2005. Orientering fra Miljøstyrelsen Nr. 3.

Danish Energy Agency (DEA), 2021: The Danish energy statistics, Available at: <https://ens.dk/en/our-services/statistics-data-key-figures-and-energy-maps/annual-and-monthly-statistics> (Jan. 2022).

DSt, 2010: Statistics Denmark – Yearbook 2010. Available at (In Danish): <https://www.dst.dk/da/Statistik/Publikationer/VisPub?cid=15197> (Feb. 2021).

DSt, 2021: Statistics Denmark - Agricultural Statistic from year 1990 to 2019. Available at: <http://www.dst.dk/en.aspx> (Jan. 2022).

Elsgaard, L., Olsen, A.B. & Petersen, S.O. 2016: Temperature response of methane production in liquid manures and co-digestates, *Sci. of the Total Env.* 539, pp 78-84.

EMEP/EEA air pollutant emission inventory guidebook, 2019. Available at: <https://www.eea.europa.eu/publications/emep-eea-guidebook-2019> (Feb. 2022).

Feidenhans'l, B., 2009: Amount of straw burnt. Barthold Feidenhans'l, SEGES, personal communication.

Hafner, SD. Nyord, T. Sommer, GS. Adamsen, AP. 2021. Estimation of Danish emission factors for ammonia from field-applied liquid manure for 1980 to 2019. 138 pp. Advisory report from DCA – Danish Centre for Food and Agriculture, Aarhus University, submitted: 23-09-2021.

Hansen, M.N., 2021: Årlig statistik for kalkforbruget i landbruget. Available at: https://www.landbrugsinfo.dk/planteavl/goedskning/kalkning/sider/pl_18_2439_po_kalkstatistik.aspx (Jan. 2022).

Hansen, N.E. 2010: Department of Basic Animal and Veterinary Sciences/ Animal Nutrition, Faculty of Life Science, University of Copenhagen. Pers. comm., mail 13.12.2010.

Hansen, T.L., Sommer, S.G., Gabriel, S. & Christensen, T.H. 2006: Methane production during storage of anaerobically digested municipal organic waste. *J. Environ. Qual.*, 35, 830-836.

Hellwing, A.L.F., Weisbjerg, M.R. & Lund, P., 2014: Note: Calculation of Y_m for dairy cows in Denmark. Department of Animal Science, Aarhus University, AU Foulum, P.O. Box 50, DK-8830 Tjele, Denmark.

Hellwing, A.L.F., Weisbjerg, M.R., Brask, M., Alstrup, L., Hymøller, L., Larsen, M.K., & P. Lund (2016). Prediction of the methane conversion factor (Y_m) for dairy cows on the basis of national farm data. *Animal Production Science*, 56, 535-540. <https://www.publish.csiro.au/an/AN15520>

Husted, S. 1994: Seasonal variation in methane emission from stored slurry and solid manures. *J Environ Qual.* 23:585-592.

IPCC 2006: 2006 IPCC Guidelines for National Greenhouse Gas Inventories. Available at: <http://www.ipcc-nggip.iges.or.jp/public/2006gl/index.html> (Feb. 2022).

IPCC, 2014: 2013 Supplement to the 2006 IPCC Guidelines for National Greenhouse Gas Inventories: Wetlands, Hiraishi, T., Krug, T., Tanabe, K., Srivastava, N., Baasansuren, J., Fukuda, M. and Troxler, T.G. (eds). Published: IPCC, Switzerland. Available at: <http://www.ipcc-nggip.iges.or.jp/public/wetlands/> (Feb. 2022).

Kai, P., Birkmose, T. & Petersen, S. 2015: Slurry in Danish livestock Buildings. Report by AgroTech to the Danish Energy Agency, pp 32.

Knudsen, L., 2004: Baggrund for kalkningsvejledning 2004. Planteavlsorientering - 07-521 Landbrugsinfo.dk, SEGES. (In Danish). Available at: https://www.landbrugsinfo.dk/Planteavl/Goedskning/Kalkning/Sider/Baggrund_for_kalkningsvejledning_2004.aspx (Feb. 2022).

Knudsen, T., 2011: Amount of inorganic fertiliser used in private gardens. Personal communication. Troels Knudsen, Plantedirektoratet, now the Danish Agricultural Agency.

Kold, J., 2019: Number of horses in Denmark in 2018. Meeting of the board of representatives for Dansk Rideforbund, 06.04.2019, Jørgen Kold, SEGES.

Laursen, B. 1987: Normtal for husdyrgødning. Report no. 82, Institute of Food and Resource Economics, University of Copenhagen (previously referred to as Statens Jordbrugsøkonomiske Institut) (In Danish).

Laursen, B. 1994: Normtal for husdyrgødning - revideret udgave af rapport nr. 28. Report no. 82, Institute of Food and Resource Economics, University of Copenhagen (previously referred to as Statens Jordbrugsøkonomiske Institut) (In Danish).

Luostarinen S. & Kaasinen, S. 2016: Manure nutrient content in the Baltic Sea countries. National resources and bioeconomy studies 40/2016. Natural Resources Institute Finland (Luke).

Lund, Peter, 2014: Personal communication. Department of Animal Science – Animal nutrition and physiology, Aarhus University.

Lund, P., Hellwing, A.L.F. & Weisbjerg, M.R., 2020: Fremskrivning af metan-omdannelsesfaktoren (Y_m) for malkekøer. Opdatering 2020. Department of Animal Science, Aarhus University. In Danish. Available at: https://pure.au.dk/portal/files/185773485/Fremskrivning_af_metanomdannelsesfaktoren_OPDATERING_2020_220420.pdf (Feb. 2022).

Lund, P., Hellwing, A.L.F. & Weisbjerg, M.R., 2021. Fremskrivning af metan-omdannelsesfaktoren (Y_m) for malkekøer i årene 2025, 2030, 2035 og 2040. 14 sider. Rådgivningsnotat fra DCA – Nationalt Center for Fødevarer og Jordbrug, Aarhus Universitet, leveret: 21. november 2021.

Lundgaard. N.H., 2006: Personal Communication: Department of Farm buildings and Machinery. Danish Agricultural Advisory Centre.

Madsen, H.B., Nørr, A.H. & Holst, K.A., 1992: Atlas over Danmark, Serie I, Bind 3, Den Danske Jordklassificering. Det Kongelige Danske Geografiske Selskab. (in Danish). Available at: <https://rdgs.dk/publikationer/atlas-over-danmark-serie-1-bind-3-den-danske-jordklassificering.pdf> (Feb. 2022).

Madsen, M.L.N, Kiilerich, O., Andersen, N.H, Andersen, M.V.S. & Sander, J., 2020: Affaldsstatistik 2019. Environmental Protection Agency. Available at: <https://www2.mst.dk/Udgiv/publikationer/2020/12/978-87-7038-249-6.pdf> (Feb. 2022).

MEFD, 2017: Ministry of Environment and Food in Denmark. Agreement on food and agriculture package in December 2015: Available at (in Danish): https://mfvm.dk/fileadmin/user_upload/FVM.dk/Dokumenter/Landbrug/Indsatser/Foedevare_og_landbrugspakke/Aftale_om_foedevare_og_landbrugspakken.pdf (Jan. 2022).

Mikkelsen, M.H., Albrektsen, R. & Gyldenkærne, S., 2011: Danish emission inventories for agriculture. Inventories 1985 - 2009. National Environmental Research Institute, Aarhus University. 136 pp. – NERI Technical Report No. 810. Available at: <http://www2.dmu.dk/Pub/FR810.pdf> (Jan. 2021).

Mikkelsen, M.H., Albrektsen, R. & Gyldenkærne, S., 2014. Danish emission inventories for agriculture. Inventories 1985 – 2011. Aarhus University, DCE – Danish Centre for Environment and Energy, 142 pp. Scientific Report from DCE – Danish Centre for Environment and Energy No. 108. Available at: <http://dce2.au.dk/pub/SR108.pdf> (Feb. 2022).

Mikkelsen, M.H., Gyldenkærne, S., Poulsen, H.D. Olesen, J.E. & Sommer, S.G., 2006: Emission of ammonia, nitrous oxide and methane from Danish Agriculture 1985-2002. Methodology and Estimates. NERI Research Notes Nr. 231/2006. Available at <http://www2.dmu.dk/Pub/AR231.pdf> (Feb. 2022).

MST, 2020: Affaldsstatistik 2019. Miljøstyrelsen, ISBN: 978-87-7038-249-6. Available at (In Danish): <https://mst.dk/service/publikationer/publikationsarkiv/2020/dec/affaldsstatistik-2019/> (Feb. 2022)

Møller, H.B. & Moset, V., 2015: Methane emissions from liquid manure storage – influence of temperature, storage time, substrate type and anaerobic digestion. Draft Final report 2015, Biogas Taskforce. Aarhus University, Department of Engineering.

Nielsen, O.-K., Plejdrup, M.S., Winther, M., Gyldenkærne, S., Thomsen, M., Fauser, P., Nielsen, M., Mikkelsen, M.H., Albrektsen, R., Hjelgaard, K., Hoffmann, L. & Bruun, H.G., 2013. Quality manual for the Danish greenhouse gas inventory. Version 2. Aarhus University, DCE – Danish Centre for Environment and Energy, 44 pp. Scientific Report from DCE – Danish Centre for Environment and Energy No. 47. Available at:
<http://www.dmu.dk/Pub/SR47.pdf> (Feb. 2022).

Nielsen, O.-K., Plejdrup, M.S., Winther, M., Mikkelsen, M.H., Nielsen, M., Gyldenkærne, S., Fauser, P., Albrektsen, R., Hjelgaard, K.H., Bruun, H.G. & Thomsen, M. 2021. Annual Danish Informative Inventory Report to UNECE. Emission inventories from the base year of the protocols to year 2019. Aarhus University, DCE – Danish Centre for Environment and Energy, 580 pp. Scientific Report No. 435. Available at:
<http://dce2.au.dk/pub/SR435.pdf> (Jan. 2022).

Olesen, J.E., Fenhann, J.F., Petersen, S.O., Andersen, J.M. & Jacobsen, B.H. 2001: Emission af drivhusgasser fra dansk landbrug. DJF rapport nr. 47, markbrug, Danmarks Jordbrugsforskning, 2001. (In Danish).

Olesen, J.E., Jørgensen, H., Danfær, A., Gyldenkærne, S., Mikkelsen, M.H., Asmon, W.A.H. & Petersen, S.O., 2005: Evaluering af mulige tiltag til reduktion af landbrugets metanemissioner. Arbejdsrapport fra Miljøstyrelsen Nr. 11 /2005. Chapter 1 (Allan Danfær): Methane emission from dairy cows. Available at:
<http://www2.mst.dk/Udgiv/publikationer/2005/87-7614-699-5/pdf/87-7614-700-2.pdf> (Feb. 2022).

Petersen, C. & Kielland, M., 2003: Statistik for jordbrugsmæssig anvendelse af affaldsprodukter fra husholdning og institutioner og virksomheder 2001. Miljøprojekt nr. 858 2003. The Danish Environmental Protection Agency.

Petersen, S.O., Olsen, A.B., Elsgaard, L., Triolo, J.M. & Sommer, S.G., 2016: Estimation of Methane Emissions from Slurry Pits below Pig and Cattle Confinements. PLoS ONE 11(8): e0160968. doi:10.1371/journal.pone.0160968

Poulsen, H.D., Børsting, C.F., Rom, H.B. & Sommer, S.G., 2001: Kvælstof, fosfor og kalium i husdyrgødning – normtal 2000. DJF rapport nr. 36 – husdyrbrug, Danmarks Jordbrugsforskning. (In Danish).

Poulsen, H.D. & Kristensen, V.F., 1997: Normtal for husdyrgødning – en revidering af danske normtal for husdyrgødningens indhold af kvælstof, fosfor og kalium. Beretning nr. 736, Faculty of Agricultural Sciences, Aarhus University (In Danish).

Poulsen, H.D. & Kristensen, V.F. 1998: Standards Values for Farm Manure – A revaluation of the Danish Standards Values concerning the Nitrogen, Phosphorus and Potassium Content of Manure. DJF Report No. 7 - Animal Husbandry. Danish Institute of Agricultural Sciences. Available at:
<http://web.agrsci.dk/djfpublikation/djfpdf/djfhnd7.pdf> (Feb. 2022).

- Rasmussen, J.B., 2006: Personal Communication. Department of Farm buildings and Machinery. Danish Agricultural Advisory Centre.
- Rodhe, L.K.K., Ascue, J., Willén, A., Persson, B.V. & Nordberg, Å., 2015: Greenhouse gas emissions from storage and field application of anaerobically digested and non-digested cattle slurry.
- Rodhe, L., Ascue, J. & Nordberg, Å., 2009: Emissions of greenhouse gases (methane and nitrous oxide) from cattle slurry storage in Northern Europe. IOP Conf. Ser. Earth Environ. Sci. 8, 012019. doi:<http://dx.doi.org/10.1088/1755-1315/8/1/012019>
- Rodhe, L.K.K., Abubaker, J., Ascue, J., Pell, M. & Nordberg, Å., 2012: Greenhouse gas emissions from pig slurry during storage and after field application in northern European conditions. Biosyst. Eng. 113, 379–394. doi:<http://dx.doi.org/10.1016/j.biosystemseng.2012.09.010>
- SEGES, 2005: Møller, J., Thøgersen, R., Helleshøj, M.E., Weisbjerg, M.R., Søgaard, K. & Hvelplund, T. Fodermiddeltabel 2005. Rapport nr. 112. The Danish Agricultural Advisory Service, Department for Cattle. (In Danish).
- Skade, M., 2020: Personal communication. The Danish Agricultural Agency.
- Sommer, S.G., Christensen, M.L., Schmidt, T. and Jensen, L.S., 2013: Animal Manure Recycling: Treatment and Management. ISBN: 978-1-118-48853-9, 382 pages, September 2013.
- Sommer S.G., Petersen S.O. & Møller H.B. 2004: Algorithms for calculating methane and nitrous oxide emissions from manure management. Nutrient Cycling in Agroecosystems. 69, 143-154.
- Stenkjær, K., 2010: Number of pheasants. Personal communication.
- Sørensen, P. 2021. First estimate for N content in catch crops. Intern note, Department of Agroecology - Soil Fertility, Aarhus University.
- Sørensen, P.B., Illerup, J.B., Nielsen, M., Lyck, E., Bruun, H.G., Winther, M., Mikkelsen, M.H., & Gyldenkærne, S., 2005: Quality manual for the greenhouse gas inventory Version 1. National Environmental Research Institute, Denmark. 25 pp. – Research Notes from NERI no. 224. – Available at: http://www2.dmu.dk/1_viden/2_Publikationer/3_arbrapporter/rapporter/AR224.pdf (Feb. 2022).
- Taghizadeh-Toosi, A., Olesen, J. E., Kristensen, K., Elsgaard, L., Østergaard, H. S., Lægdsmand, M., Greve, M.H., Christensen, B.T., 2014: Changes in carbon stocks of Danish agricultural mineral soils between 1986 and 2009. European Journal of Soil Science. Vol. 65, Issue 5, page 730-740. Available at: <https://onlinelibrary.wiley.com/doi/abs/10.1111/ejss.12169> (Feb. 2022).
- Tornbjerg, H., 2021: Henrik Tornbjerg, data received per mail. Aarhus University, Department of Ecoscience – Catchment Science and Environmental Management.
- Wang, S.-Y. & Huang, D.-J. 2005: Assessment of Greenhouse Gas Emissions from Poultry Enteric Fermentation, Asian-Aust. J. Anim. Sci. Vol 18, No. 6: 873-878.

Wiberg-Larsen, P., Windolf, J., Baattrup-Pedersen, A., Bøgestrand, J., Ovesen, N.B., Larsen, S.E., Thodsen, H., Sode, A., Kristensen, E., Kronvang, B. & Kjeldgaard, A., 2010: Vandløb 2009. NOVANA. Danmarks Miljøundersøgelser, Aarhus Universitet. 100 s. – Faglig rapport fra DMU nr. 804. (In Danish). Available at: <http://www2.dmu.dk/Pub/FR804.pdf> (Feb. 2022).

Windorf, J., 2013: Jørgen Windorf, data received per mail, 04.11.2013.

Windorf, J., Thodsen, H., Troldborg, L., Larsen, S.E., Bøgestrand, J., Ovesen, N.B. & Kronvang, B., 2011: A distributed modelling system for simulation of monthly runoff and nitrogen sources, loads and sinks for ungauged catchments in Denmark. *Journal of Environmental Monitoring* 2011, 13, 2645-2658. Available at: <http://pubs.rsc.org/en/Content/ArticleLanding/2011/EM/c1em10139k> (Feb. 2022).

Waagepetersen, J., Grant, R., Børgesen, C.D. & Iversen, T.M., 2008: Midtvejs-evaluering af Vandmiljøplan III. (In Danish). Available at: <http://pure.au.dk/portal/files/2841678/djfma142.pdf.pdf> (Feb. 2022).

6 LULUCF

6.1 Overview of the sector

This chapter covers only the territory of Denmark without the Faroe Islands and Greenland. Greenland is submitting a separate NIR as well as the corresponding CRF tables for the Greenlandic territory to UNFCCC. This can be found as Chapter 16 in this NIR.

The current submission is based on the 2006 IPCC Guidelines combined with the emission factors from the 2013 Wetlands Supplement (IPCC, 2014) Chapter 2 and 3 for CO₂, N₂O and CH₄ combined with national derived emission factors.

Denmark (Capital: Copenhagen) is situated around 56°N and 13°E and covers 43,098 km². No permanent ice is occurring and only very small insignificant areas with rocks. According to 2006 IPCC Guidelines, the climate is cold and wet. Denmark is an intensive agricultural country where most of the area is affected by agriculture. The average temperature in the standard 30-year period, 1961-1990, was 7.7°C with a minimum temperature in February of 0.3°C and a maximum in July of 17.0°C. Year 2020 was warm with an average mean temperature of 9.8°C, which is 2.1°C above the 1961-1990 average. The warmest year ever reported, since the Danish measurements began in 1884, was 2014 with an average temperature of 10.0°C.

All land is classified into Managed Forest, Cropland, Managed Grassland, Wetlands (managed and unmanaged), Settlements or Other Land (unmanaged).

6.1.1 Abbreviations

The following abbreviations are used in accordance with definitions in the IPCC guidelines:

- A: Afforestation, areas with forest established after 1990 under article 3.3.
- R: Reforestation, areas, which have temporarily been unstocked for less than 10 years - included under article 3.4.
- D: Deforestation, areas where forests are permanently removed to allow for other land use, included under article 3.3.
- FF: Forest remaining Forest, areas remaining forest after 1990.
- FL: Forest Land meeting the definition of forests.
- CL: Cropland.
- GL: Grassland.
- SE: Settlements.
- OL: Other land, unclassified land.
- FM: Forest Management, areas managed under article 3.4.
- HWP: Harvested Wood Products
- CM: Cropland Management, areas managed under article 3.4.
- GM: Grazing land Management, areas managed under article 3.4.

Other abbreviations:

- NFI: National Forest Inventory
- LULC: Land Use, Land Cover
- LPIS: Land Parcel Information System

PSU: Primary Sampling Unit (National Forest Inventory)
SSU: Secondary Sampling Unit (National Forest Inventory)
TSU: Tertiary Sampling Units (National Forest Inventory)
OC: Organic Carbon
SOC: Soil Organic Carbon
SINKs: Abbreviation for a research projects covering LULUCF
FOM: Fresh organic matter
HUM: Humified organic matter
ROM: Resilient Organic Matter
HWP: Harvested wood products

The LULUCF sector differs from the other sectors in that it contains both sources and sinks of carbon dioxide. Removals are given as negative figures and emissions are reported as positive figures according to the guidelines. For 2018, emissions from LULUCF were estimated to be a net source of 6594 Kt CO₂ equivalents or 14 % of the total reported Danish emission (excluding LULUCF).

6.1.2 Methodology overview

Tier

The type of emission factor and the applied tier level for each emission source are shown in Table 6.1 below. The tier level has been determined based on the 2006 IPCC Guidelines (IPCC, 2006).

The distinction between tier level 2 and 3 is due to differences in the emission factor used. The tier level definitions were interpreted as follows:

- Tier 1: The emission factor is an IPCC default tier 1 value.
- Tier 2: The emission factors are country specific and based on either a few emission measurements or IPCC tier 2 emission factors.
- Tier 3: Based on models, which include carbon stock changes methodologies.

Table 6.1 shows which of the source categories are key in 2020 in the respective key source analyses¹ (including LULUCF, tier 1/tier 2).

¹Key category according to the KCA tier 1 or tier 2 for Denmark (excluding Greenland and Faroe Islands), including LULUCF, level 1990/ level 2020/trend.

Table 6.1 Methodology and type of emission factor.

		Tier	EF ^a
4.A.1 Forest	CO ₂	Tier 3, Tier 1	CS, D
4.A.2 Forest, Land converted to	CO ₂	Tier 3, Tier 1	CS, D
4(II) Drainage and Rewetting	N ₂ O, CH ₄	Tier 2	D
4.B Cropland, Living biomass	CO ₂	Tier 3, Tier 2	CS
4.B Cropland, Mineral soils	CO ₂	Tier 3	CS, D
4.B Cropland, Organic soils	CO ₂	Tier 2	CS, D
4(III) Direct nitrous oxide (N ₂ O) emissions from nitrogen (N) mineralization/immobilization	N ₂ O	Tier 2	CS, D
4.C Grassland, Living biomass	CO ₂	Tier 2	CS, D
4.C Grassland, Mineral soils	CO ₂	Tier 3, Tier 2	CS, D
4.C Grassland, Organic soils	CO ₂	Tier 2	CS, D
4.D Wetlands, Living biomass	CO ₂	Tier 2	CS, D
4.D Wetlands, Soils	CO ₂	Tier 2	CS, D
4.E.2 Settlements, Living biomass	CO ₂	Tier 2	CS, D
4.G. Harvested Wood Product	CO ₂	Tier 2	D
4(V) Biomass Burning	CH ₄	Tier 2, Tier 1	CS, D
4(V) Biomass Burning	N ₂ O	Tier 2, Tier 1	CS, D

^a CS= Country Specific value. ^a D= Default value.

6.1.3 Key categories

Key Category Analysis (KCA) approach 1 and 2 for year 1990, 2020 and trend for Denmark has been carried out in accordance with the IPCC Guidelines (2006). Table 6.2 shows which of the LULUCF categories are identified as key categories. The table is based on the analysis including LULUCF. Detailed key category analysis is shown in NIR Chapter 1.5 and Annex 1.

The major key categories are the CO₂ emissions from forests remaining forest on both the level and the trend. For Cropland, both mineral and organic soils are major key sources.

Table 6.2 Key categories, LULUCF.

		Approach 1			Approach 2		
		1990	2020	1990-2020	1990	2020	1990-2020
4.A.1 Forest land remaining forest land, Living biomass	CO ₂	Level	Level				
4.A.1 Forest land remaining forest land, Dead organic matter	CO ₂		Level	Trend			Trend
4.A.1 Forest land remaining forest land, Organic soils	CO ₂		Level				
4.A.2 Land converted to forest land	CO ₂	Level	Level	Trend	Level	Level	Trend
4.B.1 Cropland remaining cropland, Living biomass	CO ₂		Level	Trend			
4.B.1 Cropland remaining cropland, Mineral soils	CO ₂	Level		Trend	Level	Level	Trend
4.B.1 Cropland remaining cropland, Organic soils	CO ₂	Level	Level	Trend	Level	Level	Trend
4.B.2 Forest land converted to cropland	CO ₂		Level	Trend			Trend
4.B.2 Other land uses converted to cropland	CO ₂			Trend			Trend
4.C.1 Grassland remaining grassland, Living biomass	CO ₂		Level	Trend			
4.C.1 Grassland remaining grassland, Organic soils	CO ₂	Level	Level	Trend	Level	Level	Trend
4.D.1.1 Peat extraction remaining peat extraction	CO ₂						Trend
4.E.2 Other land uses converted to settlements	CO ₂	Level	Level		Level	Level	Trend
4.G Harvested wood products	CO ₂		Level	Trend		Level	Trend
4(II) Cropland on organic soils	CH ₄					Level	
4(II) Grassland on organic soils	CH ₄					Level	Trend

6.1.4 Overall emission estimates

Table 6.3 gives an overview of the emission from the LULUCF sector in Denmark. The total emission in 2020 have been estimated to 3107 kt CO₂ equivalents. The Danish forest have been estimated to be a net sink of 2173 kt CO₂ equivalents. Forests have been large sink in Denmark for the last decade.

Cropland is ranging from being a net source from up to 5298 kt CO₂ equivalents in 1990 to be a net source of 2851 kt CO₂ equivalents in 2020. Cropland and grassland are general sources in Denmark due to large areas with drained organic soils. Fluctuations in the emission from cropland between years are related to the actual crop yield that year and the climatic conditions. Low crop yields combined with high temperatures reduce the total amount of carbon in agricultural soils, whereas a year with a high yield and low temperatures increase the carbon stock in soil. From 1990 and onwards, a general decrease in the emission from cropland is estimated due to the following reasons:

- A higher incorporation of straw (ban on field burning)
- Demands on growing of catch crops in the autumn, a change from low yielding spring barley to high yielding winter wheat
- An increased carbon stock in hedgerows
- A continuously smaller area with organic agricultural soils cultivated.

The area with restored wetlands has increased and the area with peat excavation has been reduced since 1990, leading to a lower emission from wetlands.

Table 6.3 Overall emission (kt CO₂ equivalents) from the LULUCF sector in Denmark, 1990 - 2020.

Total GHG, kt CO ₂ -eq.	1990	2000	2010	2015	2016	2017	2018	2019	2020
4. Total LULUCF	6873.6	5135.0	2457.5	792.2	1886.1	1820.4	3737.7	2893.0	3107.1
A. Forest land	-1228.7	-1328.8	-2269.4	-4008.0	-3121.1	-2570.3	-2124.9	-2490.2	-2172.5
1. Forest land remaining forest land	-222.9	-1180.3	-1067.5	-2903.0	-2035.6	-1469.8	-1182.4	-1230.7	-1013.6
2. Land converted to forest land	-1036.6	-178.9	-1228.5	-1132.5	-1113.1	-1128.1	-970.2	-1287.2	-1186.7
B. Cropland	5297.9	4031.2	2549.1	2562.1	2666.1	2225.7	3381.8	3051.2	2851.0
1. Cropland remaining cropland	4965.9	3750.8	2312.2	2249.8	2413.4	2051.5	3161.1	2875.0	2594.4
2. Land converted to cropland	88.6	59.3	41.6	136.1	79.4	2.5	54.0	9.0	93.3
C. Grassland	2229.7	1982.0	1880.7	2117.8	2148.9	2055.9	2218.5	2132.0	2231.9
1. Grassland remaining grassland	1981.7	1771.9	1647.8	1734.0	1895.6	1836.0	1972.7	1908.1	2004.0
2. Land converted to grassland	56.1	37.4	70.8	212.0	79.3	44.1	64.7	43.9	45.0
D. Wetlands(3)	104.8	77.8	80.4	67.5	64.6	47.1	75.7	71.0	72.3
1. Wetlands remaining wetlands	99.5	67.9	52.1	40.7	42.2	30.5	52.6	29.7	8.2
2. Land converted to wetlands	3.2	3.3	13.1	6.2	-0.4	-8.7	-3.0	14.3	35.4
E. Settlements	472.2	347.0	241.9	224.3	301.7	224.2	232.9	213.5	242.1
1. Settlements remaining settlements	0.0	0.0	0.0	0.0	0.0	0.0	0.0	0.0	0.0
2. Land converted to settlements	472.2	347.0	241.9	224.3	301.7	224.2	232.9	213.5	242.1
F. Other land	0.0	0.0	0.0	0.0	0.0	0.0	0.0	0.0	0.0
G. Harvested wood products	-2.4	25.8	-25.1	-171.6	-174.0	-162.2	-46.2	-84.6	-117.6

6.1.5 Land presentation

Approximately 60 % of the total Danish land area is cultivated and 15 % forested. Together with a high number of cattle and pigs, there is a high (environmental) pressure on the landscape. To reduce the impact, an active policy has been adopted to protect the environment. The adopted policy aims at doubling the forested area in 1990 within a tree generation (80-100 years), restoration of former wetlands and establishment of protected national parks. In Denmark, almost all natural habitats and all forests are protected. Therefore

only limited conversions from forest or wetlands into cropland or grassland are occurring.

No permanent snow cover exists in Denmark and only a very small insignificant area with rocks and cliffs. Other Land is thus restricted to beaches and sand dunes.

The official land area is 43 098 km². The Land Use Matrix has estimated the total area to 43 056 km². This area includes rivers and lakes. The small discrepancy is due to differences in the definition of the 7000 km long coastline. The Land Use Matrix uses the latest official vector maps from Danish Geodata Agency.

The emission data are reported in the CRF format under IPCC categories 4A (Forest land), 4B (Cropland), 4C (Grassland), 4D (Wetlands) and 4E (Settlements) and 4F (Other land).

Fertilisation of Forests and Other Land is negligible and the whole Danish fertiliser consumption is therefore reported in the agricultural sector. Field burning of biomass is prohibited in Denmark. Wildfires in forest are reported. This is normally around 0-10 hectares per year, but due to the drought in 2018, the number of wildfires increased from approx. 500 hectares to more than 2000 hectares; mainly in cropland and grassland and a few in forests. In 2019, Denmark went back to normal conditions with controlled burning of heathland taking place on approximately 100-300 hectares to maintain the heathland vegetation.

Savannas and rice cultivation do not occur in Denmark.

Estimation of carbon stock changes in the Danish forests is based on a combination of previous forest surveys and the present National Forest Inventory (NFI).

The cropland and grassland areas are based on agricultural EU subsidiary systems and are very detailed. A drawback is, however, that one field in one year can be classified as cropland and the next year as grassland, and then again converted back to cropland. This may create large conversion rates between cropland and grassland.

Table 6.4 shows the overall development in the land use classes from 1990 to 2020. Observe that the changes in Table 6.4 are from January 1st 1990 and onwards. This means that the sum of the figures is slightly different from those reported in the CRF tables, because these are reported at the end of year 1990. Afforestation is mainly taking place on cropland and grassland, which has not previously been classified as forest. Areas, which are deforested, are mainly converted to wetlands, settlements or grassland. Only a very limited area is converted to cropland. Since 1990, 52 488 hectares have been changed into settlements and other infrastructure. No land is converted into other land.

Christmas trees on agricultural land are reported under forest land. This despite the fact that Christmas trees often are clear cut and may later on have an intermediate agricultural crop before it is again replanted with Christmas trees. The total area with Christmas trees was approximately 28 749 ha in 2020. In addition, some forest areas are also used for Christmas tree production,

giving a total area of more than 33 000 ha of Nordmann Christmas trees (Nord-Larsen et al., 2019).

In the Land Use Matrix, a linear approach for all land use changes has been adopted for the period 1990 to 2005 and from 2005 to 2011. From 2011 and onwards, annually updated data from the different data suppliers are used. However, some of the data are not updated annually, and thus a time lag in the implementation of the land use changes may occur in some areas. Conversion to annual updates therefore creates more fluctuating area changes than in the previous years.

There are large area fluctuations between cropland and grassland in the annual field data in the IACS/LPIS² information (Integrated Administration and Control System/Land Parcel Information System) data. This cannot be seen as real changes in land use, but merely in the farmers definition of their fields actually use, the Land Use Matrix shows large changes. The effect of this has been taken into account and minimized as much as possible by including a rule that an agricultural field shall have been reported in the IACS/LPIS system as e.g. grassland, before it is moved from cropland to grassland and vice versa.

Table 6.4 Land Use Change from 1990 to 31. December 2020 based on GIS vector layers and Earth Observations^a.

1990\2020	Forest	Cropland	Grassland	Wetlands	Lakes	Settlements	Other	Sum
Forest								528998
Cropland	103539	2749956	84659	10442	4004	45555	0	2998155
Grassland	7230	43022	79980	10115	1871	4782	0	146999
Wetlands	1558	687	9	47452	42	108	0	49856
Lakes	0	0	0	0	52951	8	0	52958
Settlements	0	0	0	0	0	486614	0	486614
Other	0	0	0	0	0	0	26433	26433
Sum	641326	2801920	168917	68737	59118	539101	26433	4305552
Percentage	14.9%	65.1%	3.9%	1.6%	1.4%	12.5%	0.6%	100.0%
1990\2020	Forest	Cropland	Grassland	Wetlands	Lakes	Settlements	Other	Sum

^a Please observe that the matrix is from 1st January 1990. The figures are therefore not identical with figures given in the CRF tables, which are end of year 1990 data.

6.1.6 Methodology for land use presentation

The terrestrial area, which is defined as the inland land area above the highest tidal limit, forms the physical frame for the estimation of land-use changes. The coastal area from the inland tidal limit to the seaward extend of vascular plants is very limited in Denmark. In cases where these exist, they are often covered by coastal salt marches. These are included in the land-use category grassland. The object type “regions” from the national topographic database Kort10 (Danish Geodata Agency, 2011) was applied to represent the Danish terrestrial area. The object type covers 43 051 km², which corresponds to the total terrestrial area provided in the statistical yearbook for 2012 (Statistics Denmark, 2012). The object type was applied for 1990, 2005 and for 2011, assuming the total terrestrial area of Denmark has not changed during the assessed period.

² IACS/LPIS is an EU system where all agricultural fields are defined with its actual crop and its precise location. These data are fully available for the Danish inventory.

From 2011 and onwards, annual updates of the Land Use Matrix is used with the help from multiple available data sources. The annual updates create larger fluctuations in the annual changes compared to the period 1990-2005 and 2005-2011 because the observed changes over multiple years are averaged out.

The Land Use Matrix is developed by giving the most certain data highest priority and the least certain information a lower priority. In Denmark is the most certain data the Danish building register (BBR, <https://bbr.dk/forside>), then with a higher uncertainty the cadastral maps, changes in roads, annually updated agricultural land parcel maps, new subsidized afforestation and hedges, restored wetlands etc. Today is both the BBR and the cadastral maps online instant updated and available for all. Many public data can be found here:

<https://arealinformation.miljoportal.dk/html5/index.html?viewer=distribution>

The category of settlements is defined as developed land including transportation infrastructure and human settlements. For this assessment, settlements were divided into built up land, related to urban land uses and into infrastructure, comprising roads and railways. The built up layer is based on 12 object types derived from Kort10 (Danish Geodata Agency, 2011), the Danish Area Information System (AIS, 2002) and from the cadastre map (Danish Geodata Agency, 2012) combined with the Danish building register (BBR) (Ministry of Housing, Urban and Rural Affairs, 2012). Object types representing built up land are not readily available historically. Therefore, the estimation of change in built up land is based on the national cadastre map (Danish Geodata Agency, 2011), combined with the Danish building register (Ministry of Housing, Urban and Rural Affairs, 2011). For each existing building, the register contains the building year and a link to the id-number of the cadastre on which the building is located. Based on this information, all cadastres containing buildings were assigned a building year, referring to the first year of establishment of a building. This map was overlaid with the built up layer for 2011, which then was divided into areas built up before 1990, areas built up between 1990 and 2005 and areas built up between 2005 and 2011. The method is illustrated in Figure 6.1.

Cropland is defined as land intensively utilized for agricultural purposes. Grassland, which is part of an annual agricultural rotation cycle, is included in the cropland category. Grassland is defined as agricultural permanent grassland, which is used for grazing and other areas where the vegetation is maintained in a state that implies no trees with a crown cover of at least 10 percent, in which case it would meet the definition for forest. Grassland includes among other, extensively managed grassland, dry grassland and heathland. Information about cropland and grassland from 2011 was derived from the agricultural register from 2011 to 2020 (Ministry of Environment and Food of Denmark, 2021) in combination with the field parcel map for 2011 (Ministry of Food, Agriculture and Fisheries, 2011b). The field parcel map contains land use information for all field parcels, managed by land managers (e.g. farmers) who have applied for EU subsidies (Land Parcel Information System, LPIS). The field parcel map contains more than 270 types of crops/land-use classes. These were aggregated into four classes: cropland, grassland, forest and wetland. Furthermore, grassland was also derived from the national registration of protected habitat types (Arealinformation, 2011a) and from management plans for state forests (Danish Nature Agency, 2011)

from the management plans for defence holdings (Danish Defence, 2011) and from the registration of habitat types within Natura2000 designations (Arealinformation, 2011b). Hedges and biotopes not qualified to be Forest Land are included as a separate class in Cropland. Hence, no perennial wooden crops are reported under grassland.

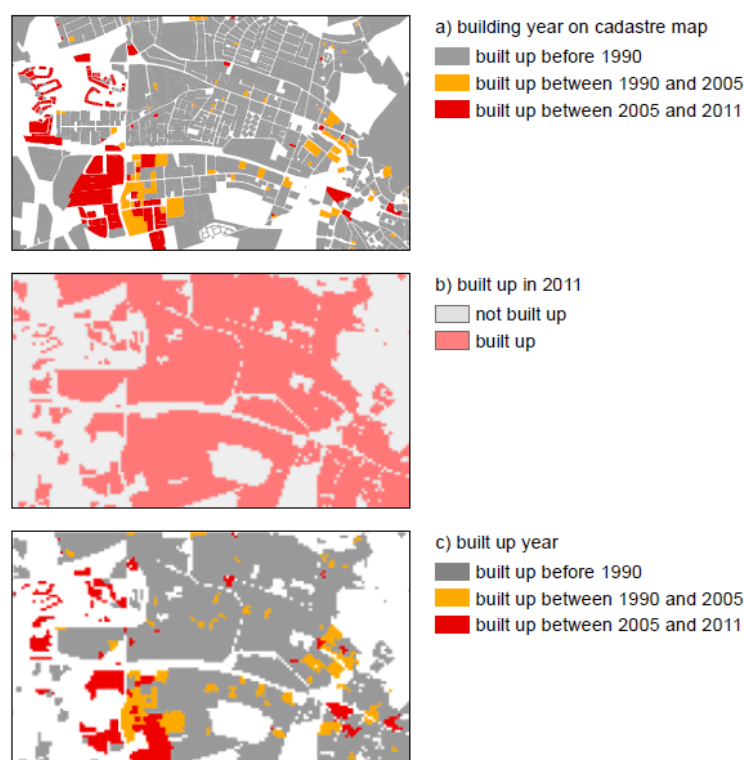

Figure 6.1 Illustration of change detection in settlement. Applying information from the Danish building register, cadastres were classified into cadastres built up before 1990, built up from 1990 to 2005 and built up between 2005 and 2011 (a). This map was overlaid with the built up layer for 2011, which was derived from Kort10 (b). Subsequently the built up layer was classified into areas built up before 1990, built up between 1990 and 2005 and built up between 2005 and 2011 (c).

Forest is defined as woody vegetation covering a minimum of 0.5 ha with a minimum width of 20 m. The vegetation must have a minimum tree crown cover of 10 % and a minimum height of 5 m or be able to obtain these values *in situ*. In addition, the forest area includes temporarily unstocked areas, smaller open areas in the forest needed for management purposes, such as fire breaks. Forests in national parks, reserves or areas under special protection are included. Conifers for production of Christmas trees as well as forest for energy production, except willow plantations, are also reported under forest. Fruit plantations for commercial purposes, orchards, gardens etc., which might be able to reach the forest definition, are reported in the cropland layer.

Mapping of forest area in 1990 and 2005 was conducted in 2011 based on Landsat 5 Thematic Mapper scenes from 1989-90 and 2005-06 and SPOT XS. Images were purchased from Eurimage, USGS EROS Data Center, and Image2006. The imagery was resampled to 25 meters using a quadratic mapping function and 17 nearest neighbour resampling with a minimum of 20 ground control points per scene. For 2011, a national forest map was created based on Landsat data acquired during 2010 and 2011. For a full description, see Levin et al. (2014).

Wetlands are divided in three categories, i.e. peat excavation areas, fully covered wetlands, such as lakes and other permanent water bodies and in partly water covered wetlands. Fully water covered wetlands are represented by the object type "Lake" in the registration of protected habitat types (Arealinformation, 2011a) and other new information. Partly water covered wetlands are defined as land that is covered or saturated by water part of the year and areas with peat extraction. Partly water-covered wetlands include bogs, freshwater meadows, coastal meadows and marshlands as reported in Arealinformation, 2011a and other new information.

Other land comprises all land uses, which is not included in the other five land use categories. It is defined as beaches, sand dunes and rock and has none or very limited carbon stock, both as living or dead biomass or as carbon in the soil. Other land as represented in the applied input datasets from 2011 was decided to be representative for the whole period from 1990 to 2011. I.e. in the final estimation of Land Use/Land Cover (LULC) changes, the area covered by other land is stable.

In contrast to the estimation of land-use changes until 2011, for the period after 2011 fewer data sources are used. For cropland, grassland, afforestation and wetland restoration is annually used updated field parcel maps representing information from the agricultural register (Ministry of Environment and Food of Denmark, 2021) for cropland, grassland and wetland including conversion to and from. Further, the topographical database Kort10 (Danish Geodata Agency, 2012) has been used for settlements. For the remaining input datasets, the land use information for 2011 was also applied for 2012 and onwards.

Assessment of land-use changes

After conversion to raster format, the settlement layer and the field parcel layer for 2012 were embedded in the 2011 LULC map. In principle, the same hierarchy as for the 2011 map was applied. However, following exceptions were made:

1. For cells, where forest changes to settlement, the forest layer from Kort10 (Danish Geodata Agency, 2012) was applied to qualify the cell as forest. I.e. if the forest layer from Kort10 contains forest, the cell is kept in forest in 2012, otherwise the cell is attributed the change from forest to settlement.
2. Cells, which change from non-forest in 2011 to forest in 2012, are only registered as afforestation if the cell contains forest in at least two successive years. I.e. that afforestation is registered if the cell contains forest in 2013. Therefore, afforestation is registered with a delay of one year. Consequently, no afforestation is registered from 2011 to 2012. Afforestation from 2011 to 2012 is registered in the estimation of land use/land cover change from 2012 to 2013.
3. For cells, where LULC changed from grassland, cropland or wetland in 2011 to undefined LULC in the field parcel map for 2012, the cell is attributed the LULC from the 2011 map.
4. Cells, which from one year to the next shows a change from CL to GL or vice versa is kept in the same LULC, unless the cell has been in the same state for the last five year.
5. Cells with wetland (permanently covered) or with other land in 2011 are kept in the same class in 2012, also if 2012 data indicate a change. If the information for 2012 indicated a change in LULC, the type and extent of

change was assessed. In cases where information for 2012 indicated no change as well as cases where the input layers for 2012 (settlement layer or field parcel map) did not contain any LULC information, LULC was reported unchanged.

A considerable proportion of changes, especially those including agricultural land uses, only contain few cells. These changes are most probably the result of imprecise mapping of input datasets (particularly for the field parcel maps), rather than actual changes. Therefore, regions, which change and have a size of ≤ 8 cells or 0.5 ha, were not accepted. This is in accordance with the elected Danish minimum forest definition (IRR, 2007) and the 2006 IPCC Guidelines (IPCC, 2006). These regions were identified and the land use category for 2011 was applied to the 2012 map and onwards.

In 2018, a validation of the resulting methodology was performed and reported in Johannsen et al. (2018). Results indicate that generally, the accuracy of land uses and land covers for the assessed years are reasonably high. For the reporting detailed analysis of the affected areas (Lidar based biomass maps - Nord-Larsen et al., 2017a) provides information on the estimated changes, reducing the impact of the uncertainty.

6.2 Forest land (4A)

Table 6.5 shows the total area reported under forest land under the Convention. The area with forest land has increased since 1990 due to an intensive afforestation programme. In the beginning of the 1990's, approximately 3000 ha were afforested every year. In recent years, approximately 1500 ha are afforested per year. The estimated emission from organic matter varies between years. Mineral soils are a small sink due to the afforestation. The CO₂ emission from organic soils is slightly reduced over time due to rewetting of the organic soils in the forests.

Table 6.5 Total area and annual emissions 1990 to 2020 from forest land.

	1990	2000	2010	2015	2016	2017	2018	2019	2020
Area, 1000 ha	548.7	590.8	627.7	637.5	637.5	638.6	639.1	640.1	641.3
Living and dead biomass, kt C	-311.1	-335.3	-588.4	-820.2	-569.3	-435.4	-308.7	-396.6	-370.3
Litter, kt C	-68.6	-63.9	-44.7	-287.1	-290.8	-270.6	-272.8	-284.6	-224.5
Dead wood, kt C	-5.0	-5.1	-15.4	-22.7	-28.8	-33.3	-37.0	-37.7	-38.1
Mineral soils, kt C	-11.7	-16.6	-19.4	-17.8	-17.3	-16.7	-16.2	-15.6	-15.2
Organic soils, kt C	52.6	50.2	45.8	47.3	47.4	47.5	47.6	47.7	47.9
Total, kt C	-343.8	-370.7	-622.0	-1100.6	-858.7	-708.5	-587.1	-686.8	-600.1
CH ₄ , kt CH ₄	0.199	0.205	0.140	0.144	0.144	0.145	0.145	0.150	0.146
N ₂ O, kt N ₂ O	0.090	0.085	0.077	0.080	0.080	0.080	0.081	0.081	0.081
Total, kt CO ₂ eqv.	-1228.7	-1328.8	-2254.2	-4008.0	-3121.1	-2570.3	-2124.9	-2490.2	-2172.5

The forest definition adopted in the NFI is identical to the definition used by the Food and Agriculture Organization (FAO, 2010, Annex 2). It includes "wooded areas larger than 0.5 ha, that *in situ* are able to form a forest with a height of at least 5 m and crown cover of at least 10 %. The minimum width is 20 m." Temporarily non-wooded areas, firebreaks and other small open areas, that are an integrated part of the forest, are also included. The temporarily un-stocked areas make up 3 % and auxiliary areas 2 % of the total forest area. The temporarily un-stocked areas are caused by e.g. clear cutting and wind throw and are generally required to be reforested within a 10-year period according to the Forest Act. It is part of standard forest management in Danish

Forestry to perform clear cuttings. The forest area has consistently included these unstocked areas, ensuring consistency over time for the stock change method.

6.2.1 Forest census 1881-2000

From 1881 to 2000, a National Forest Census was carried out roughly every 10 years based on questionnaires sent to forest owners (e.g. Larsen and Johannsen, 2002). Since the data were based on questionnaires and not field observations, the actual forest definition may have varied. The basic definition was that the tree-covered area should be minimum 0.5 ha to be a forest. There were no specific guidelines as to crown cover or the potential height of the trees. Open woodlands and open areas within the forest (temporarily unstocked areas excepted) were generally not included. All estimates of growing stock, biomass or carbon pools for this period were based on data from the National Forest Census (reference year 2010) and the distribution of the forest area with reference to the census to main species, age classes and growth regions (Jutland and the Islands). In this way the carbon stocks back in time for the Forest Census in 1951, 1965, 1976, 1990 and 2000 were estimated applying similar procedures as applied in current reporting and in estimation of reference levels for Danish forests (Johannsen et al. 2019). The estimation also included the forest area mapping described in section 6.2.3 for the years 1990 and 2000, expecting the additionally found forest area to be of lower stocking density than the area reported in the forest census. A detailed description of the recalculation will be given in Johannsen & Stupak, 2021. The overall development is given in the figure below.

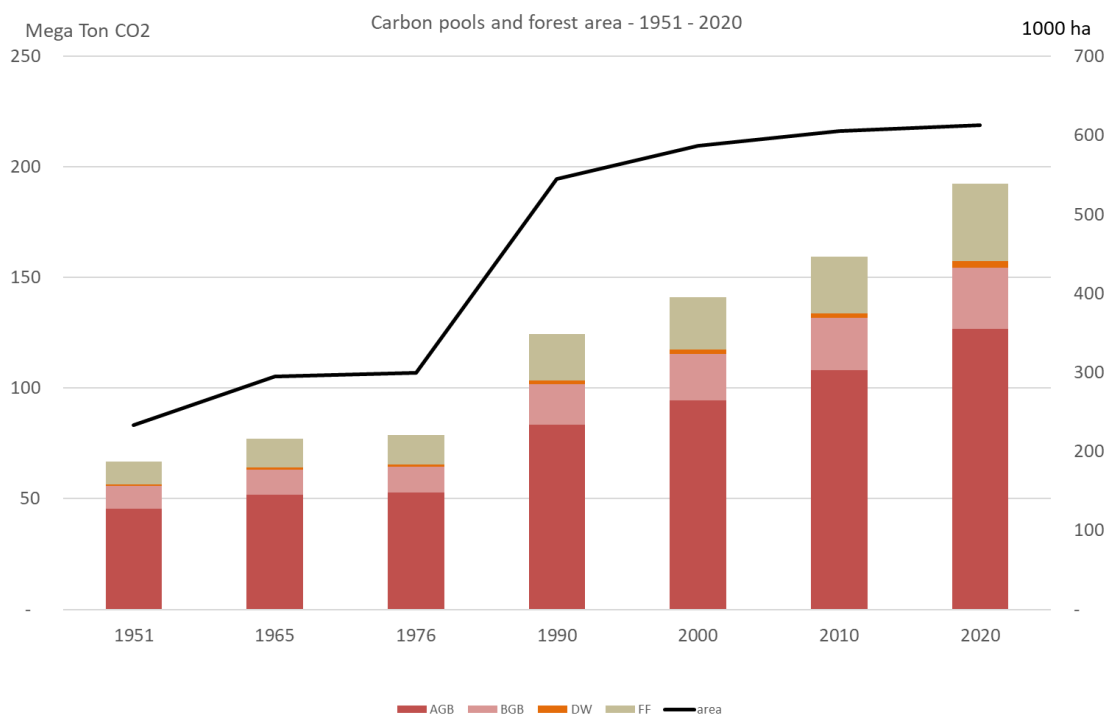

Figure 6.2 Forest carbon in forests based on forest census data for 1951-2000 and NFI data for 2006-2020.

6.2.2 National Forest Inventory (NFI) 2002-

In 2002, the current sample-based National Forest Inventory (NFI) was initiated (Nord-Larsen and Johannsen, 2016). The design of the inventory is very similar to inventories used in other countries such as Sweden or Norway. The NFI has replaced the National Forest Census.

The Danish NFI is a continuous sample-based inventory with partial replacement of sample plots based on a 2 x 2 km grid covering the Danish land surface. In each grid cell, a cluster of four circular plots (primary sampling unit, PSU) for measuring forest factors (e.g. wood volume) are placed in the corners of a 200 x 200 m square. Each circular plot (secondary sampling unit, SSU) has a radius of 15 meters. When plots are intersected by different land-use classes or different forest stands, the individual plot is divided into tertiary sampling units (TSU).

About one third of the plots is assigned as permanent. These plots are re-measured in subsequent inventories every five years. Two thirds of the plots are temporary and are selected randomly among the particular 2 x 2 km grid cell with forest cover in subsequent inventories. The sample of permanent and temporary field plots from the 2 x 2 grid has been systematically divided into five non-overlapping, interpenetrating panels, which are each measured annually and constitute a systematic sample of the forest land of the entire country. Hence, all the plots are measured in a five-year cycle.

A detailed description of the Danish NFI is presented in Nord-Larsen and Johannsen (2016).

In the most recent five-year rotation of the NFI (2015-2019), the number of clusters (PSU) and sample plots (SSU) containing forest were 4 333 and 9 570, respectively; see Table 6.6. In the reporting, estimation of carbon pools in the period with the forest census (1954 – 2000) have been harmonized with the results of the NFI, both in terms of the area estimation (as described above in the paragraph **Error! Reference source not found.** on land use mapping) and in terms of the carbon pools. The estimates of all forest carbon pools are based on direct NFI measurements from 2002 and onwards, with no usage of yield tables. As there are no field sampled data prior to 2002, there are no systematic way of harmonization the NFI data with the previous census data. The area and species distribution have been compared and reported in previous publications, e.g. Nord-Larsen et al. (2021).

Table 6.6 Number of measured clusters and sample plots in the five-year rotation 2016-2020.

Year	Clusters		Sample plots	
	Total	Forest	Total	Measured
2016	2 184	857	8 572	1 858
2017	2 212	853	8 652	1 899
2018	2 191	902	8 586	2 014
2019	2 186	844	8 597	1 896
2020	2 190	887	8 569	1 886
Total	10 963	4 344	42 976	9 558

Note: Measured plots are plots that are selected for inventory based on aerial photographs.

6.2.3 Forest area mapping

Due to differences in methodologies, major inconsistencies in forest areas and other forest variables are observed between the different forest inventories (i.e. the 1990 and 2000 Forest Census and the National Forest Inventory (NFI) from 2002). With the objective to obtain time consistent and accurate estimates of forest areas to report to the UNFCCC, two projects aimed at mapping the forest area in Denmark based on satellite images for the years 1990, 2005 and 2011.

A land use/land cover map was produced for the base year 1990 and for the year 2005 based on EO data (23 August 1990) and other data collected from 1992-2005 and for 2005 using NFI *in situ* data. Forest maps were developed using satellite imagery - mainly Landsat 5 (Thematic Mapper) and 7 (ETM+) data - to classify and estimate the area of different forest cover types in Denmark. Portions of seven scenes covering the whole country were classified into forest and non-forest classes. The approach involved the integration of sampling, image processing and estimation. A detailed QA/QC process was conducted in 2011/2012. Maps for 2011 were produced in 2012. In order to map the forest cover, multi-spectral and multi-temporal Landsat data of June 2010 and April 2011 with a spatial pixel resolution of 30 m were used. Except for the island of Bornholm, none of the scenes were cloud-free. So, to obtain a national forest cover map without gaps, the forest cover map of some minor areas is solely based on one image.

The product is specified by a Minimum Mapping Unit of 0.5 ha, a geometric accuracy of < 15 m RMS and a thematic accuracy of 90 % +/- 5 % for the land use class Forest.

In combination with the Forest Census back to 1881 it is possible to characterise the forest area into Forest Remaining forest and Afforestation younger than 30 years. This gives a development at shown in the figure below, where significant afforestation have been performed throughout the described period (1960-2019). Further details are given in Johannsen & Stupak (2021).

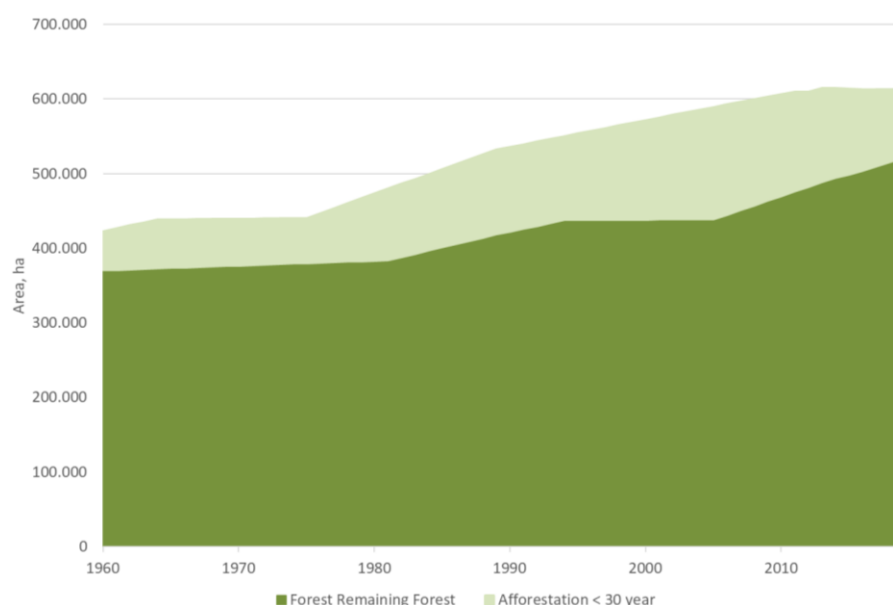

Figure 6.3 Forest area – focus on forest remaining forest and afforestation younger than 30 years.

In the updated land use matrix includes increased afforestation in areas without support from public funds as well as establishment of minor forests areas, to improve hunting options and to produce biomass. Some forest areas have been established through natural succession, a method now approved by the Forest Act (from 2005). The area of Christmas trees is handled as a specific part of the forestland use and the dynamics therein are handled directly in the estimation of the carbon pools.

6.2.4 Estimation of forest carbon pools

In the following, procedures for estimating forest carbon pools are described in general. For a more detailed description of the calculations and the specific formulas used, readers are referred to Nord-Larsen and Johannsen (2016).

Estimation of forest area – for carbon pool estimates

Based on an analysis of the most recent aerial photos (Kortforsyningen, 2020), each NFI sample plot (SSU) is allocated to one of three forest status categories, reflecting the likelihood of forest or other wooded land in the plot: (0) Unlikely to be covered by forest or other wooded land, (1) Likely to be covered by forest, and (2) Likely to be covered by other wooded land. All NFI sample plots within clusters (PSU) with one or more SSU belonging to (1) or (2) are inventoried in the field.

Overall forest cover fraction is calculated as the sum of the forest covered plot area divided by the total sample plot area. In this calculation, the forest area in plots belonging to (0) is assumed to be 0 (zero). In the early years of the NFI, not all sample plots were inventoried due to insufficient resources. Furthermore, every year some plots are inaccessible due to infrastructure, water, or dangerous conditions on the site (e.g. leaning trees after wind throw). The estimated forest area in un-inventoried plots belonging to 1 or 2 was assumed to equal the average forest area in inventoried plots belonging to 1 or 2.

The overall forest area is calculated as the overall average forest cover fraction in the sample plots with status categories (0), (1) and (2) times the total land area.

The fraction of forest area with a specific characteristic, such as forest established before or after 1990, is estimated as the forested plot area with the particular characteristic divided by the total forested plot area. The total forest area with a particular characteristic is subsequently found as the fraction of forest area with the particular characteristic times the total forest area.

Estimation of volume, biomass and carbon pools

Growing stock is calculated using species-specific individual tree volume functions developed for the most common Danish forest tree species (e.g. Madsen, 1987; Madsen, 1987; Madsen & Heusèrr, 1993). The functions use individual tree diameter and height as well as quadratic mean diameter of the forest stand as independent variables. For trees lacking volume functions, volumes are calculated using functions for trees with a similar phenology.

Biomass (dry mass) and carbon stocks are calculated using species specific individual tree biomass models developed for the most common forest tree species in Denmark with tree diameter and height as input (Nord-Larsen et al., 2017a). For species where no biomass function is available, above ground biomass is calculated as the stem volume times the basic density (e.g. Skovsgaard et al., 2011, Skovsgaard & Nord-Larsen, 2012, Moltesen, 1988). Finally, total biomass (below and above ground) is estimated using expansion factors for tree species with similar phenology (Skovsgaard et al., 2011, Skovsgaard & Nord-Larsen, 2012, Nord-Larsen & Nielsen, 2015). For calculation of forest biomass and carbon pools, national individual tree volume and biomass functions are available for beech, oak, ash, silver fir, Norway spruce, grand fir, Douglas fir, Sitka spruce and Japanese larch. This means that species-specific biomass models are applied for 57 % of the area and 73 % of the total standing volume. Only for the remaining species, the generic models for

beech (Skovsgaard & Nord-Larsen, 2012) and Norway spruce (Skovsgaard et al., 2011) are applied. It has not been tested systematically, but they are expected not to be biased in terms of biomass or carbon estimates. Total growing stock, biomass and carbon stocks are estimated by obtaining an estimate of average stocks per hectare on inventoried NFI plots times the overall forest area. The total growing stock, biomass or carbon stocks with a given characteristic are estimated as the sum of the stocks with the particular characteristic divided by the inventoried plot area, times the total forest area. Biomass is converted to carbon using a concentration of 0.47 g C g^{-1} . Full documentation of the estimation and calculations of biomass and carbon pools are given in (Nord-Larsen & Johannsen, 2016). For further info on areas and volume for the specific species, see (Nord-Larsen et al., 2020).

Dead wood volume, biomass and carbon content

The volumes of standing dead trees and lying dead trees with their base inside the sample plots are calculated using individual tree volume functions, similarly to the calculations for live trees. The volume of lying dead tree parts (e.g. broken off branches, but excluding lying dead trees with their base outside the sample plot), within the sample plot is calculated as the length of the dead wood times the horizontal cross sectional area at the middle of the dead wood piece. Biomass of the dead wood is calculated as the volume multiplied with species specific basic densities (Moltesen, 1988) and a reduction factor of the density according to the structural decay of the wood (decay class). Biomass is converted to carbon using a concentration of 0.47 g C g^{-1} .

Similar to live biomass, total dead wood biomass and carbon stocks are estimated by obtaining an estimate of average stocks per hectare on inventoried NFI plots times the overall forest area.

The carbon pool in living and dead biomass estimated for the most recent rotation of the NFI (2016-2020) is 43 million tonnes C (Figure 6.2). The largest pool is living aboveground biomass carbon makes up 81 % of the carbon in total biomass, while the smallest pool is dead wood carbon that makes up only 1 % of the carbon in total biomass. Carbon in biomass in forests established after 1990 makes up 4 % of the total carbon in forests established before and after 1990.

For the reporting to the Convention the forest remaining forest area are for all the years focusing on the area with more than 30 years of forest cover. The afforested area and carbon pools related to this of the age class of 30 year, is transferred each year to the forest remaining forest reporting. This is conducted as described in section 6.2.8 on the Stock change method.

Forest floor

Forest floor depth is measured on all NFI plots in the annual census by the method described in the NFI protocol (Knudsen et al., 2019). Carbon stocks are subsequently calculated by multiplying the forest floor depth with species-specific forest floor basic densities and C concentrations (Vesterdal & Raulund-Rasmussen, 1998).

Christmas trees

Christmas trees are recorded as forest, as the areas fulfil the forest definition applied. The Christmas tree plantations occur on both traditional Forest Land (FL) and on areas formerly used for Cropland (CR). The Christmas trees are managed intensively compared to forest in many cases. Carbon stock in

aboveground living biomass, based on the NFI data for Christmas trees, is estimated to 0.01 kt C ha⁻¹ and 0.002 kt C ha⁻¹ in the belowground biomass. No dead wood or litter layer of significance is present in these stands and their carbon stocks is therefore set to 0 (zero).

6.2.5 Emission from soils

Forest mineral soil and organic soil

According to decision 16/CMP: “A Party may choose not to account for a given pool in a commitment period if transparent and verifiable information is provided that the pool is not a source”. The forest soil inventory aims to document that forest soils are not a source for emissions of CO₂, i.e. that there is no detectable depletion of soil carbon. This may be called the “no source principle.” According to the 2006 IPCC Guidelines (IPCC, 2006), the necessary documentation may come from various information sources such as:

- Representative and verifiable sampling and data analysis to show that the pool has not decreased.
- Reasoning based on sound knowledge of likely system responses.
- Surveys of peer-reviewed literature for the activity, ecosystem type, region and pool in question.
- Combined methods.

Based on a survey of literature and reasoning based on sound knowledge there is little evidence to support that the soil C pool in forest remaining forest would currently be changing to an extent that would be detectable by sampling with decadal frequency.

As supplement to the NFI monitoring, a representative and verifiable forest soil inventory has been implemented in order to provide further documentation that forest soils are not an overlooked source for CO₂ emissions and to be able to distinguish the area with mineral soils from area with organic soils, with the latter being defined by a topsoil carbon concentration of 12 % organic carbon (OC) in the 0-25 cm soil layer below the O-horizon. Based on this definition, organic forest soils have been estimated from the first inventory from 2007-2010 to represent 5 % of the forest area. This fraction is consistent with the map classification of organic soils using the [Digital Geological Map of Denmark \(1:25.000 and 1:200.000\)](#). For organic soils, the default carbon source emission factor of 2.6 t C ha⁻¹ yr⁻¹ was used (Wetlands supplement (IPCC, 2014, Table 2.1). The forest soil inventory does not provide separate estimates on emissions for forest soils with 6-12 % OC as for Cropland (CL) and Grassland (GL). Hence only emissions from organic forest soils > 12 % OC are reported.

Since the reporting in 2009 for years 1990-2007, quantitative information has gradually become available; the project “SINKS”, initiated in 2007, has delivered data from 125 plots for estimation of soil pool C change based on repeated sampling of soils in forests remaining forests for two points in time, 1990 and 2007-2010. Data on soil pool C change from additional ca. 285 resampled plots will be made available in 2021 from the project “SINKS2”, with the first sampling in 2009-2010 and first resampling in 2020.

The sampling is taking place in two grids, the so-called “Kvadratnet” (Agricultural network, 7 x 7 km, 126 plots) and the NFI grid (2 x 2 km, 285 plots). The “Kvadratnet” made it possible to estimate soil C pools in 1990 based on C concentration measurements of soil samples archived from sampling

around 1989-1990 and test if they differ from soil C pools based on soil sampling during 2007-2010. The analysis of the data from these 108 re-measured sites (sampled in six depth sections: forest floor, 0-10, 10-25, 25-50, 50-75 and 75-100 cm, with some variation for historical reasons) suggested that mineral forest soil C pools are not a source of CO₂ and thus supported that more accurate estimates of soil C pool removals/emissions do not need to be included in the reporting (Callesen et al., 2015). The methodology of the 2007-2010 survey is described in Callesen et al. (2015).

Considering the forest structure in Denmark with many small forests (about 70 % of the forest estates are of less than five hectares) the “Kvadratnet” is a very coarse grid. Even if the grid was fully sampled, it is therefore unlikely that the 108 plots represent the Danish area of forests remaining forest of approximately 500 000 ha. Based on power analyses, it was evaluated in 2007 that further sampling is necessary for future monitoring and a randomly selected subset of the permanent plots of NFI was included for this purpose. In 2007-2010, in total 277 plots were sampled in six depth sections: forest floor, 0-10, 10-25, 25-50, 50-75 and 75-100 cm. The samples were processed as described in Callesen et al. (2015). A re-sampling of these plots was taking place in 2019-2020, together with the “Kvadratnet” plots and it will be possible to provide further documentation if forest soils are a sink or a source of carbon by the end of 2021.

Soil carbon stock changes in forest remaining forest

Mineral soil C stocks in forest remaining forest are estimated at an average of 155 t C ha⁻¹ to 1 m depth for soils with < 12 % C in the 0-25 cm layer. For organic soils, it is estimated at 500 t C ha⁻¹. These estimates are based on the full sampling from the “SINKS”-forest soil project. No overall changes in Soil Organic Carbon (SOC) stock to 1 m depth were detectable in mineral soils in a depth of 0-100 cm between 1990 and 2007-2009 (Callesen et al. 2015).

Emissions from wet and drained forest soils

The 2013 Wetlands Supplement (IPCC, 2014), Figure 1.2, p 1.6) has introduced new soil categories including ‘Mineral wet soils’ and ‘Mineral drained soils’ (inland or coastal) as soil categories in addition to the formerly used ‘Dry mineral soils’ (IPCC, 2006). These categories are small and knowledge is uncertain with respect to activity data and emission factors. A range has been indicated in the reporting, but we are aware of the need for better assessment of SOC levels and effects of rewetting on non-CO₂ greenhouse gases. The peat definition of the soil map used for activity data (category FT – ferskvandstørv’ is ‘peat formed by accumulation of dead organic plant material in lakes, near streams or in moorlands’ – a limit of at least 12 % C applies to this definition.

The temporal change in shares of drained and rewetted soils has been assessed based on trends in forest management (Table 6.7) focusing on the period with most pronounced change 1990-2008, based on expert assessment of observed trends in the past 20-30 years of active maintenance of pre-existing ditches in forests. Before 1990 and after 2008 the share of drained soils are considered constant in relation to the reporting.

Table 6.7 Outline of assumptions on drainage changes over time for mineral and organic soils in forest.

Share, %	Mineral soil		Organic soil	
	Drained (ditched)	Undrained (not ditched)	Drained (ditched)	Undrained (not ditched)
1990 - 2008	65% - > 55% (0.5% points per year)	35% - > 45% (0.5 % points per year)	75%	25%
After 2008	55%	45%	50%	50%

The area of rewetted mineral and organic soil following the previously reported area shares of ditched/unditched is:

Rewetted mineral soil: 65 % - 55 % = 10 % of total forest area on mineral soils.

Rewetted organic soil: 75 %-50 % = 25 % of total forest area on organic soils.

Reporting of nitrous oxide emissions

The only soil category for which nitrous oxide emissions apply is 'organic soils, drained', and default emission values have been used. Measurements of nitrous oxide emissions from conditions applying for organic drained soils in Denmark are scarce or lacking. Danish measurements that apply to a hydromorphic, loamy soil were 0.4 - 0.6 kg N₂O-N ha⁻¹ yr⁻¹ (Christiansen et al., 2012b), which is similar to the low end of the uncertainty range given in the 2013 Wetlands Supplement value, Table 2.5 (IPCC 2014).

Organic soils, drained: 2.8 (range 0.57 - 6.1) kg N₂O-N ha⁻¹ yr⁻¹ (Table 2.5 in IPCC 2014, p. 2.33). Remaining soil categories do not apply, since they are either too dry or too wet to produce nitrous oxide.

Reporting of methane emissions

The following emission factors for methane were identified (Table 6.8); we note that units vary between chapters in 2013 Wetlands Supplement (IPCC 2014). A default area of 2.5 % ditches was assumed. Table numbers refer to the 2013 Wetland Supplement (IPCC 2014).

Table 6.8 Identified emission factors for methane and nitrous oxide in 2013 Wetlands Supplement (IPCC 2014) used in methane emission calculations.

CH ₄ EF for organic drained soils	Table 2.3	kg CH ₄ /ha/yr	2.5
CH ₄ EF for ditches on organic drained soils	Table 2.4	kg CH ₄ /ha/yr	217.0
CH ₄ EF for organic rewetted poor soils	Table 3.3	kg CH ₄ -C/ha/yr	92.0
CH ₄ EF for organic rewetted rich soils	Table 3.3	kg CH ₄ -C/ha/yr	216.0
CH ₄ EF rewetted Inland Mineral Wetland Soils	Table 5.4	kg CH ₄ /ha/yr	235.0
N ₂ O EF for organic drained soils	Table 2.5	kg N ₂ O-N/ha/yr	2.8
N ₂ O EF for ditches on organic drained soils		NO	
N ₂ O EF for organic rewetted poor soils		p.3.19 'negligible'	
N ₂ O EF for organic rewetted rich soils		p.3.19 'negligible'	
N ₂ O EF rewetted Inland Mineral Wetland Soils	No info in WS chap 5 IWMS	Assumed negligible	

In a Danish study of three forests in eastern Denmark on hydromorphic soils, the reported methane emissions were -0.08 - 3.2 kg CH₄ ha⁻¹ yr⁻¹ (Christiansen et al. 2012a; Christiansen et al. 2012b). The default value for drained organic soils seems to be reasonable until national estimates are better founded by representative measurements. Since no water level measurements in ditches and rewetted soils are available, it is not possible to judge whether the 2013 Wetland Supplement (IPCC, 2014) default values for methane emissions apply to Danish conditions.

6.2.6 Stock change methodology

Stock change method

The stock change method is based on actual assessment of carbon stock at two given points in time and provides estimates of change over time as given by the difference between the two consecutive inventories of carbon stocks.

A special issue arises when the area changes over time because afforestation area of a certain age is transferred to the forest remaining forest category. In these situations, there needs to be a special focus on the area and associated carbon stock that is transferred from the afforestation category to the forest remaining forest land category. This is required in order to assign the actual change to the afforestation including the growth/harvest/mortality of the last year, before transferring the carbon stock of the age class to the forest land carbon stock. Therefore, the stock of the age class to be transferred remains in the afforestation until the end of the year (December 31) and is transferred by the beginning of the next year (January 1). This is done on an annual basis. The principle is illustrated in Table 6.9 by the following example for time T1 and T2, one year apart. Age X indicates the age of transition from afforestation to forest remaining forest land, i.e. 30 years.

Table 6.9 Principle for handling transfer of area from afforestation to forest remaining forest. X representing age 30 years.

Area (ha) by 1.1 of:	T1	T2	Stock density t CO ₂
Forest remaining forest	100	100	75
Afforestation of age X-2	7	2	10
Afforestation of age X-1	10	7	11
Afforestation of age X	14	10	12
Afforestation of age X+1	8	14	13
Afforestation of age X+2		8	14
Total forest area	122	132	

The area development and stock density leads to the following development in stocks, Table 6.10 (note equilibrium stock is assumed on the remaining forest land area).

Table 6.10 Principle for handling transfer of stock from afforestation to forest land. X representing age 30 years.

Stock (t CO ₂ eqv.) by 1.1	T1	T2
Forest Remaining Forest (FRF)	7.500	7.500
Afforestation of age X-2	70	20
Afforestation of age X-1	110	77
Afforestation of age X	168	120
Afforestation of age X+1	104	182
Afforestation of age X+2	0	112
Forest Remaining Forest (bold figures)	7.772	7.914
Stock in the full area	7.952	8.011

A raw estimate of stock change T1-T2 would be 7914-7722=142, but the transfer of carbon stock from afforestation of age 30 =120 needs to be deducted, as this has only just been included in the FRF pool and the growth occurred before the transfer. This results in a real stock change on the area already in the FRF pool of 142-120=22. This equals the change in carbon stock of the forestland (=0), and the afforestation of age 30+1 and 30+2 (182+112-168-104) =22.

For the afforestation area the raw estimate of stock change T1-T2 would be (20+77-70-110) =-83. Again the stock of the afforestation of age 30 = 120 needs

to be taken into account, this time added, as the growth occurred before the transfer to the FRL pool. This results in a real stock change for the afforestation of $-83+120= 37$.

The overall change of the stock T1-T2 in the full forest area is 59, which is the sum of changes in the pool under forest land and under afforestation and hence ensuring consistency.

This principle is applied in the reporting of the Danish forest carbon pools to address the significant influence of the afforestation on the overall stock change in the Danish forest area.

Annual change estimates

The reporting is based on two subsequent NFI rotations of 5 year with no overlapping in observation years. This ensures the focus on robust estimates of change from the forest area. This applies to both forest remaining forest, and the afforested area.

6.2.7 Uncertainties and time series consistency

Danish national forest resource assessment has developed over the years from the earliest forest census more than a century ago to the current national inventory. More recently, the development has been quite rapid, thus influencing the estimation of forest carbon pools in relation to LULUCF.

In the 1990 forest census, the number of questionnaires sent to respondents was 22 300. In the subsequent inventory in 2000, the number of respondents increased to 32 300. This led to a substantial increase in estimated forest area, which is not possible to separate from the actual increase in forest area that occurred during that period of time.

In 2002, the sample based forest inventory substituted the previous forest census, for the first time enabling forest statistics based on direct measurements and a consistent forest assessment according to the FAO forest definitions. Consequently, the change from questionnaire based forest census to sample based forest inventory has led to considerations on how to ensure the consistency over time. This have been obtained by combination of the satellite based forest mapping (se 6.2.3) and re-estimation of the carbon pools back in time (see Johannsen & Stupak, 2021). For the period from 2006 and onwards, only data from the Danish NFI is used. With the continued improvement of the aerial photographs forming the first sampling in the NFI, a gradual improvement of the forest area estimates were observed from the start of the NFI in 2002 and until 2008-2010. This coincide with the period where part of the afforestation in the 1976-1990 period had high increment rates, resulting in an overall large increase in the observed carbon pools in the total forest area.

In the estimation of the changes reported in each year, the different data (census based and NFI based) influence the frequency of updates. This causes the change estimates in the period from 1951 – 2000 to reflect the intervals of the census. I.e. average annual change for the interval between to subsequent census are estimated based on carbon pool estimates in the census year. E.g. 1951-1965, 1965-1976, 1976-1990 and 1990 -2000. Since the NFI are applied from 2006, the change from 2000-2006 are reporting the linear transition to the NFI based estimates. For the period from 2006 and onwards, the Danish NFI the change estimation needs to be based on two independent datasets, to avoid reporting of random sampling differences rather than actual changes. Hence,

the reporting is based on two subsequent NFI rotations of five year with no overlapping in observation years. This ensures the focus on robust estimates of change from the forest area. This applies to both forest remaining forest, and the afforested area.

In a statistical sense, the Danish NFI has a cluster design with unequal cluster size. The estimation of carbon stocks is therefore associated with a statistical uncertainty. Design based estimators are available for such designs, but the Danish NFI design is further characterised by the partitioning of sample plots and unequal representation of different tree sizes within the circular sample plots. Considering the nature of the design, derivation of an analytical estimator may be a dubious undertaking.

A Tier 1 uncertainty estimates can be found in Table 6.11.

Table 6.11 Tier 1 estimates of the uncertainty for the forest.

		1990	2020					
		Emission/ sink, kt	Emission/ sink, kt	Activity data, %	Emission factor, %	Combined uncertainty	Total, un- certainty,	Uncertainty, 95 %, kt
4.A Forests		-1228.7	-2172.5				7.2	156.3
4.A.1 Forest land remaining forest land, Living biomass	CO ₂	-244.4	-300.2	5	2	5.4	5.4	16.2
4.A.1 Forest land remaining forest land, Dead organic matter	CO ₂	-127.0	-836.3	5	3	6.0	6.0	50.0
4.A.1 Forest land remaining forest land, Organic soils	CO ₂	147.4	123.0	10	50	51.0	51.0	62.7
4.A.2 Land converted to forest land	CO ₂	-1036.6	-1186.7	10	9	13.3	13.3	157.6
4(II) A. Forest land, organic soils	CH ₄	4.3	3.7	10	90	90.6	90.6	3.3
4(V) Biomass Burning	CH ₄	0.7	0.0	10	30	31.6	0.0	0.0
4(V) Biomass burning	N ₂ O	0.4	0.0	10	30	31.6	0.0	0.0

6.2.8 QA/QC and verification

Continuous focus on the measurements of carbon pools in forest contribute to QA/QC and to the verification of the submissions. As we gain more data through resampling of permanent plots in the NFI, this will further support the verification of the data reported.

On-going development of the NFI in terms of sampling procedures and estimation methods is essential for the continued QA/QC process of the NFI.

New models for biomass calculations have previously been implemented based on a substantial dataset collected in long-term common garden experiments with tree species. Further, improvements to the existing biomass models were made by adding a novel set of biomass data, including six new broad-leaved species (Nord-Larsen et al., 2017a). Further, projects aimed at improving consistency of forest carbon pool estimation across Europe (Diabolo), is expected to yield a new set of biomass equations from a very large dataset collected across Europe.

Integration with multi-phase and multi scale inventory, e.g. through other in-situ data like LiDAR scanning or satellite imagery, will contribute to the continued QA/QC process of the NFI and the carbon stock estimates for forests, when funding for this part of the verification becomes available.

6.2.9 Recalculation

In this reporting some recalculations have been implemented. In the following some key points are highlighted, mainly affecting afforestation (as also described in chapter 6.2.11).

Organic soils:

To ensure consistency with all reporting on forest area and share of forest area on organic soils, a recalculation were performed for this. I the afforestation conducted since 1990 the data from the SINKS: Forest soil project and the mapping of afforestation, have revealed that 10 % of this afforestation have been on organic soils, whereas the forest area from before 1990 have 5 % organic soils on average. In the Kyoto reporting, this have been reported correctly, but in the Convention reporting an error was detected. The error previously lead to a lower share of organic soils in the convention reporting and hence a lower reporting of emissions from soils. In the recalculation there is now consistency in the reporting and the share of organic soils are now consistent in all the reporting.

Ground vegetation in afforestation

To account for the grasses and herbs in the first 25 years of afforestation (corresponding to the situation in grasslands), an estimate of this is included. In practice, it is assumed that afforestation initially will hold the same pools of AGB and BGB as unmanaged grassland (Table 6.12). These pools will linearly decrease over a period of 25 years, reflecting the reduced light to ground vegetation from the increasing crown cover of the trees established in the afforestation. This is supported by a number of observations of afforestation, with data for both trees and grass vegetation.

6.2.10 Planned improvements

Below is a list of planned improvements.

- A constant focus on the QA/QC of the Land Use Matrix with focus on afforestation, deforestation vs temporary unstocked areas.
- Based on the NFI increasing focus will be to find and provide indications of the frequency of harvesting/thinning occurring on all of the forest area, including afforested areas. This to ensure distinction of temporarily unstocked areas and deforestation.
- New data sources based on e.g. ALS/LiDAR and satellite data will potentially improve the estimates and the mapping process, but requires more development to be implemented on an annual reporting basis. Initiatives are ongoing at national scale to achieve this.
- SINKS2, which is a continuation of SINKS project, is ongoing for further documentation of possible developments in carbon pools in soil and forest floor. It is expected that the data analysis and the results are ready for application in the reporting by the end of 2022, as delays have occurred due to the COVID-19 pandemic. SINKS2 will deliver: 1) improved data for bulk densities of forest floor for modelling of forest floor C stocks based on forest floor depth measurements from the NFI, 2) estimates of SOC changes over time based on ca. 400 plots in DK compared to 125 plots at present, 3) new estimates of cropland to forest conversion effects on SOC based on repeated sampling and modelling, 4) bulk density measurements in mineral soil for development of improved pedo-transfer functions for estimation of bulk densities from measured soil C concentrations with an improve range of coverage that also includes soil with high C concentrations.

6.2.11 Land converted to forest

See section 6.2.1-6.2.8 for information on approaches used for representing land areas and on land-use databases used for the inventory preparation.

Forest definition

The definition of land converted to forest corresponds to the definition used for forest remaining forest (see section 6.2) and the LULUCF categories used elsewhere.

Methodological issues for land converted to forest.

When converting land to forestland, the standing living above- and below ground biomass is assumed to be removed from the land. For land converted, e.g. from cropland, a standard default loss value of 9 577 kg DM (dry matter) per hectare in above ground biomass and 2 298 kg DM per hectare in below ground biomass is used. This value is equivalent to the average harvest of living biomass for all cereals grown in Denmark from 2000 to 2010, including straw, stubble and glumes based on data from Statistics Denmark combined with expansion factors. The expansion factors are those used in modelling of turnover of organic matter in agricultural soil with the dynamic model, C-TOOL, see section 6.3.7. For conversion from DM to carbon, a default concentration of 0.47 g C g⁻¹ is used. The default values for the amount of living biomass removed is shown in Table 6.12.

Table 6.12 Default values for the amount of DM (dry matter, kg per hectare) used for estimating carbon stock changes where land use conversions take place. The default C stocks in mineral soil (<6%C in 0-25 cm) are used for estimation of C stock changes following land-use change.

		Dry matter, kg DM		Default C stock in mineral soil, tonne C/ha
		Above ground biomass	Below ground biomass	
Forest land				142 ^c (excl. ff)
Christmas trees		21 277	4 255	142
Cropland		9 577	2 298	120.8
Grassland	Improved Grassland	2 400	6 720	142 ^a
	Unmanaged Grassland	2 200	6 160	142
Wetlands	Peat extraction	0	0	NE
	Other Wetland	3 600	10 080	NE
Settlements		2 200	2 200	96.6 ^b
Other land		0	0	NA

^a Same as for forest land.

^b 80 % of the carbon stock in Cropland (IPCC chapter 8.3.3.2).

^c Average of all forest mineral soils (<6 % SOC, 262 plots in NFI and "Kvadratnettet").

Carbon pools of living and dead biomass and forest floors

As with forest remaining forest, Denmark applies the stock change method, hereby including both growth and harvesting in the overall estimation. The estimation of the different pools are based on the methodology for the Danish NFI, as described above for the area of forest remaining forest.

The amount of carbon in biomass in forests younger than 30 years established after 1990 has been assessed based on data from the latest NFI. This estimate reflect the composition of species and sites in the afforestation. Since there are no available data on the afforestation younger than 30 years back in time, the density in terms of carbon pools per hectare estimated for 2019 are applied for all reporting years, taking into account the varying area. There have been variations in the afforestation back in time to 1960 in terms of species and soil type composition. In the earlier afforestation, a higher proportion have been

conifers, which could increase the pool due to higher growth. But at the same time a higher proportion have been on poorer soils, which could reduce the pool due to lower growth. Changes in management mainly affect the forest area after the age of 30. This results in applying the following estimates for the average carbon pools in afforestation areas of age 0-30: Above ground biomass 14.1 t C/ha, Below ground biomass 3.2 t C/ha, Dead wood 0.1 t C/ha and forest floor 6.4 t C/ha.

Similarly, the carbon pools in the age class of 30, which is transferred from the afforestation area to the forest remaining forest area is based on the estimation of this based on the composition of the afforestation 1990-2019, but focusing only on the age class 30. These considerations result in applying the following estimates for the age class 30: Above ground biomass 48.5 t C/ha, Below ground biomass 9.7 t C/ha, Dead wood 0.2 t C/ha and forest floor 6.9 t C/ha.

For further details, see Schou et al. (2014), Johannsen et al. (2019) and Johannsen & Stupak (2021).

To account for the grasses and herbs in the first 25 years of afforestation (corresponding to the situation in grasslands), an estimate of this is included. In practice it is assumed that afforestation initially will hold the same pools of AGB and BGB as unmanaged grassland (Table 6.12). These pools will linearly decrease over a period of 25 years, reflecting the reduced light to ground vegetation from the increasing crown cover of the trees established in the afforestation. This is supported by a number of observations of afforestation, with data for both trees and grass vegetation (see also Chapter 6.2.9).

Mineral soil

Several previous national field studies (Vesterdal et al., 2002b, Vesterdal et al., 2002a, Vesterdal et al., 2007) did not suggest statistically significant changes in mineral soil carbon in the decades following afforestation. In the forest soil inventory (SINKS project), the SOC content in depth 0-100 cm in forest land remaining forest land was compared with estimated SOC in the same depth for mineral soils (< 6%C in 0-25 cm) reported from a parallel project for cropland soils (Table 6.12). This comparison indicate that mineral soils are small sinks for CO₂ following afforestation of former cropland.

6.3 Cropland (4B)

Cropland in the reporting consists of:

- Agricultural cropland, defined as agricultural crops, approx. 2.4 million ha.
- Perennial wooden crops, defined as horticultural wooden crops and willow plantations, approx. 11 000 ha.
- Hedges and small biotopes in the landscape, which do not meet the definition of forest, approx. 100 000 ha.
- Other cropland. "Other cropland" is defined as the difference between the three defined crop types and the area in the land use matrix. Consequently, Other cropland is without any major carbon stocks and typically minor roads (not included in settlements), roadsides, banks between fields without hedges etc., approx. 260 000 ha.

According to this, cropland accounts for approximately 2.8 million ha in 2020, a decline from approximately 3.0 million ha in 1990.

The total Danish cropped agricultural area of approximately 2.62 million hectare consists of approximately 570 000 individual fields, which again is located at 190 000 land parcels. This gives an average field size of around five hektare. The actual crop grown in each land parcel (LPIS) is known from 1998 and onwards. According to Statistics Denmark 222 000 ha is reported as permanent grassland. The area reported to Statistics Denmark are in the land use matrix reported under either cropland or grassland.

Table 6.13 shows the areas and the emissions from cropland from 1990 and onwards.

Table 6.13 Total area and annual emissions 1990 to 2020 from Cropland.

Cropland	1990	2000	2010	2015	2016	2017	2018	2019	2020
Area, 1000 ha	2993.2	2943.3	2883.4	2827.1	2819.0	2811.5	2810.7	2805.8	2801.9
Living and dead biomass, kt C	20.5	-8.3	-7.0	77.0	50.0	10.7	2.6	7.5	62.1
Mineral soils, kt C	278.2	66.7	-217.1	-179.9	-111.1	183.96	163.1	65.1	-25.8
Organic soils, kt C	1108.9	1007.1	889.3	773.4	760.2	753.3	729.8	732.7	714.4
Total, kt C	1407.6	1065.5	665.2	670.4	699.1	580.0	895.5	805.3	750.7
CH ₄ , kt CH ₄	5.47	4.97	4.39	4.00	3.93	3.90	3.78	3.80	3.71
N ₂ O, kt N ₂ O	0.000	0.000	0.002	0.013	0.014	0.005	0.013	0.012	0.019
Total, kt CO ₂ eqv.	5297.9	4031.2	2549.1	2562.1	2666.1	2225.7	3381.8	3051.2	2851.0

6.3.1 Cropland remaining Cropland (4B1)

Since 1990, the agricultural area recorded by Statistics Denmark has decreased from 2.78 million hectare to 2.62 million hectare in 2020 (Table 6.14). The overall cereal yield has increased with 10 % during the same period (average 1990-1994 compared to average 2016-2020) despite the decrease in the area.

Table 6.14 shows the development in the agricultural area from 1990 to 2020 (Statistics Denmark). A general trend is a continuous decrease of the agricultural area by 6000 - 7000 ha per year. From 1993 to 2008, there was a mandatory European Union regulation for set-a-side, due to overproduction of agricultural products. In these years, more than 200 000 ha were often left as set-a-side. In 2009, this regulation was lifted and the area ceased to a very low level. In the latter years the reported area has increased and for 2020 set-a-side area was reported 81 727 ha. Part of the increase of the reported area is due to a change of the definition by Statistics Denmark, but also a change in the farmers reporting. The Danish farmers receive single payment per ha, regardless of what is grown on the land and thus not bounded to the specific crops. In the carbon stock calculation for mineral agricultural soils, Denmark is using a dynamic model (C-TOOL, see section 6.3.7). In this model, the set-a-side area is treated as a specific crop similar to grassland. However, the input of organic material to the soil is lower for the set-a-side area compared to grass in rotation.

Table 6.14 Cropland area in Denmark 1990-2016 according to Statistics Denmark and the Land Use Matrix, hectares.

	1990	2000	2010	2015	2018	2019	2020
Annual crops (CL) 1	2236535	1938633	2049304	2064949	1982921	1962620	1932879
Grass in rotation (CL)	306325	330834	327319	258202	265518	284099	283256
Permanent grass (CL and GL)	217235	166261	199859	254770	212657	206687	222405
Horticulture – vegetables (CL)	16428	10803	10812	11119	12970	13515	12775
Perennial fruit trees – perennial wooden crops (CL)	10267	9892	8181	5761	5324	5324	5324
Set-a-side (CL)	0	191295	9874	4501	76377	76973	81727
Other land and uncropped areas (CL)	3861	1146	41435	33058	76377	76973	81727
Total agricultural land area reported by Statistics Denmark	2788276	2646982	2646400	2632947	2632453	2625965	2619987
Willow and other crops for energy purposes (CL)	588	695	4049	5478	4837	4837	4837
Hedgerows (CL)	98643	100602	97419	98022	98316	98347	98391

¹CL refers to that the area is reported under Cropland. GL refers to Grassland.

Despite the decreasing agricultural area, the total crop yield has increased since 1990, as measured in dry matter (million kg dry matter per year (Figure 6.4). Year 2018 was very dry and the consequences was a 25 % lower crop yield than the average.

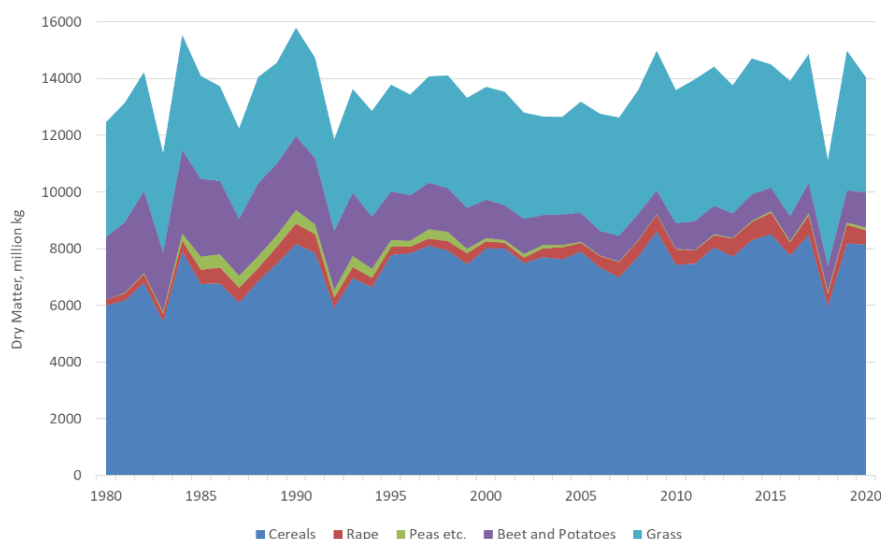

Figure 6.4 Total crop yield given as kernel, root fruits and grass as measured in dry matter (Million kg dry matter per year, Source: Statistics Denmark).

The main reason for the loss of land for agricultural purposes is urbanisation and afforestation. The major part of the agricultural area is grown with annual crops: cereals, grass in rotation, oilseed, sugar beets, potatoes and temporarily set-a-side. Permanent grass outside rotation with none or very little fertiliser application rates (>25 kg N per ha per year) is reported under Grassland. All fertilisation with nitrogen is reported under Agriculture (Chapter 5).

6.3.2 Cropland area

The Cropland area is defined as the agricultural area as given by Statistics Denmark, Perennial wooden crops (fruit trees, orchards and willow), hedgerows (perennial trees/bushes not meeting the forest definition) in the agricultural landscape and "Other agricultural land". The latter is defined as the difference in the area between the total Cropland area as defined by the land use matrix minus agricultural crops in rotation as given by statistics Denmark, minus the area with fruit trees and the area with hedgerows. "Other agricultural land" is thus comparable small areas and probably without agricultural and wooden crops, which cannot be allocated to other land use categories. In

the inventory, carbon in living biomass for “Other agricultural land” is given the same value as for annual crops so that inter-annual changes in the cropland area from Statistics Denmark are eliminated.

The area with perennial wooden crops are defined by Statistics Denmark and for some categories it is split further down with data from the EU crop subsidiary system, which gives information on which crops are grown where on species level.

The main data for land use of cropland (4.B) is the agricultural area up to 2010 is based on Statistics Denmark and from 2010 and onwards the area is taken from the EU Land Parcel Information System (LPIS). The LPIS contains information of the exact position of the field. The survey data from Statistics Denmark differs a little from the LPIS system ($\pm 2\%$ for the major crops). Area and yield data from each region are used for the calculations as reported by Statistics Denmark.

The area with hedgerows and small biotopes is based on analysis of LiDAR measurements for year 2006 and 2014/2015 (see section 6.3.6) combined with planting and removal statistics of hedges from the Agricultural Agency of Denmark. Most establishment of hedges is subsidised in Denmark and therefore monitored. In the most recent years only 30 to 40 hectare is planted every year.

6.3.3 Cropland definition

The land area under "CL" consists of Cropland with annual crops, cropland with wooden perennial crops, areas with hedgerows and “Other agricultural area”. The latter consists of small, undefined areas lying inside the area, which is allocated as cropland in the cropland area.

For purposes of the calculations for annual crops a division as follows is used: Winter and spring wheat, rye, triticale, winter and spring barley, oat, winter and spring rape, grass for grass seed production, grassland in rotation, potatoes, sugar beets, peas, maize for silage, cereals for silage, vegetables and miscanthus.

For purposes of perennial wooden crops a division as follows is used: apple, pears, cherries, plums, rosehips, elderberries, hazel and walnuts, grapes, other fruit trees, black current, other fruit bushes, hedgerows and willows.

6.3.4 Cropland - Methodological issues

The following data sources are used for determination of cropland area, for determination of any land-use changes, for allocation of natural and administrative parameters, for development of emission factors for soils and biomass and for calculation of carbon stocks in soils and biomass at various times.

- Agricultural area data from Statistics Denmark, 1980 to 2009
- Area and harvest surveys from Statistics Denmark, 1980 to 2020
- Area with willow from the agricultural subsidiary system
- EUs Land Parcel Information System, 1998 to 2020 (grown crops on field and soil level)
- Digital soil map, 1:25.000
- LiDAR analysis in 2006 and 2014/2015 combined with hedgerow planting data 1977 to 2020 (very little planting has taken place in the later years).

Emissions from living biomass

For annual agricultural crops on cropland remaining cropland (4B1), it is assumed that no changes in above-ground, below-ground, dead biomass and litter are occurring, cf. IPCC 2006 (5.2.1.1). The variations in the actual agricultural area included in the LPIS system or collected by Statistics Denmark may be up to 50 000 hectares per year. When estimating the carbon stock in living biomass such changes may create large variations between years, which may be artefacts. As the amount of living biomass is defined according to the time where the peak of living biomass is occurring, the variation in the area from Statistics Denmark creates large fluctuations in the carbon stock in living biomass compared to other sources. To counteract this problem, the sub-division "Other agricultural land" has been created with a default carbon stock of living biomass as in the designated agricultural area. The default carbon stock in living biomass is equivalent to an average spring barley crop with above-ground biomass of 9 577 kg DM (dry matter) per hectare and a below ground DM of 2 298 kg per hectare. Default dry matter values for the different crop categories used in the inventory was given in Table 6.12. This default value is based on the average cereal yield in Denmark from 2001-2010 combined with the expansions factors used in C-TOOL.

6.3.5 Fruit trees and other perennial wooden plants

Fruit trees, other perennial commercial wooden plants and durable horticultural plantations are included under cropland (CFR Table 4.B). These are only of minor importance in Denmark and cover approximately 8 770 ha in 2020 of which 4 837 ha is willow (Table 6.15) out of a total agricultural area of 2.8 million ha. The total area for different main classes and the used carbon stock in above-ground and below-ground biomass are given in Table 6.15. Due to the limited area and small changes between years, the CO₂ removal/emission is calculated without a growth model for the different tree categories. Instead, the average stock figures are used in Table 6.15 multiplied with changes in the area to estimate the annual emissions/removals. Perennial horticultural crops account for approximately 0.07 % of the standing carbon stock.

The carbon fraction of dry matter (DM) is assumed 0.5 for all species.

Table 6.15 Tonnes living biomass per hectare and area, ha, with perennial wooden trees and bushes, 1990-2020.

	Living biomass, Mg DM per ha	1990	2000	2010	2015	2018	2019	2020
Black currant	5.20	1269	1492	1848	1474	908	833	808
Other berries	5.20	663	611	620	0	0	0	0
Rosehip	13.99	0	0	197	154	188	195	191
Cherries	25.45	1787	2804	1743	1129	704	663	619
Plumes	25.45	0	0	68	67	68	81	78
Hazelnut and walnuts	25.45	0	0	14	27	35	40	56
Apples	33.76	2726	1678	1684	1519	1437	1421	1408
Pears	13.99	351	441	357	289	289	295	286
Elderberry	25.45	0	0	9	12	53	82	167
Grapes	5.20	0	0	45	79	91	105	138
Other fruit trees	13.99	0	0	60	138	91	92	100
Rowan-berries	33.76	0	0	16	26	31	31	1
Willow	17.43	588	695	4049	5478	5039	4928	4837
Miscanthus	17.43	1	6	156	69	74	77	80
Total		7385	7727	10865	10459	9008	8843	8770

6.3.6 Hedgerows

Since the beginning of the early 1930s, governmental subsidiaries have been given to increase the area with hedgerows to reduce soil erosion. In the 1950-60's, 6-9 million single rowed conifers, mainly white spruce (*Picea glauca*) was planted annually. From around 1965, the annual rate decreased sharply to almost zero in lack of financial subsidies but also because the planting turned into hedges made of broad leaf trees/plants, however, only to around 2-3 million trees. This can be converted to annually financial support given to 400-800 km of hedgerow per year. In the latter years, financial support has only been given to approx. 100 ha. From 2014, this subsidiary was ceased, however, re-established from 2016 but ceased again. There are no figures on the total removed hedges in the same period as these to a large extend are not protected.

A new model for biomass estimation in hedges and small biotopes not included in the forest definition has been included in the 2020 submission. The model is based LiDAR measurements in 2006 and 2014/2015 (Levin et al., 2020). The LiDAR measurements has a resolution of 1.6 * 1.6 m² in 2006 and 0.4 * 0.4 m² in 2014/2015. The LiDAR measurements revealed an increase in the area with hedges and small biotopes of 96 660 ha in 2006 increasing to 103 105 ha in 2014/2015 (Levin et al., 2020). In combination with project with the LiDAR analysis biomass of approximately 10 000 m (10.3 ha) was measured. The removed biomass were chipped, brought to biomass burned power plants weighed and burned. Analysis of the data showed that regardless of the height there was a stable biomass volume per m³ of hedge/biotope of 2.54 (± 0.56) kg DM m⁻³ hedge. The analysis showed a tendency that more windy regions in Denmark have slightly lower hedges but as no significant differences in the volume per m³ could be found these areas are reported with lower carbon stocks. To convert to carbon was used the IPCC default value of 0.47 and a Root/Shoot ratio of 0.192 (IPCC, 2006). The average height were estimated to 4.96 m and an average aboveground C stock of 59.2 ton C/ha. The volume density is higher than seen in the Danish NFI plots with similar heights. The most plausible explanation is that in the forest, the trees are competing for light and forced to grow vertically, whereas in the hedges more branches are produced. The measured DM m⁻³ hedge is similar to what have been found in other studies in Germany (Lingner et al., 2018) and UK (Axe et al., 2017).

Table 6.16 shows the actual planting and removal rates for hedgerows. As the planting of white spruce from the 1930's and onwards is getting old, high replacement rates were seen in the 1980's and the 1990's. Many of the white spruce hedges are now replaced by broadleaves hedges and the replacement rate has gone down as well as the immediate need for hedges to lower sand drift from cropland. In 1990, 75 % of the replaced conifers hedgerows were replaced with 3- to 6-rowed broad-leaved hedges. Over the years, a decrease in the number of subsidized hedgerows has taken place. The Danish Agricultural Agency is responsible for all administration, registration and mapping of all subsidised hedgerow planting in Denmark.

Table 6.16 Hedges planted and removed under the governmental subsidiary system 1990 to 2020.

	1990	2000	2010	2015	2016	2017	2018	2019	2020
Planted, ha	464.0	626.1	141.7	145.0	125.3	121.3	64.4	33.3	45.9
Removed, ha	522.0	219.1	13.0	4.3	8.6	6.9	1.2	2.0	2.1
Net change, ha	-58.0	407.1	128.7	140.7	116.7	114.4	63.2	31.2	43.8
Net change, kt C/yr	7.6	30.1	51.6	43.1	25.9	24.8	23.8	22.6	21.4

6.3.7 Emission from soils

Based on a GIS analysis of the data in the LPIS and a newly produced soil map of the organic soil (Greve et al., 2014), the agricultural area is distributed between mineral soils and organic soils and subdivided into cropland and permanent grassland.

Mineral soils – 4B1

For carbon changes in mineral agricultural crops, a 3-pooled dynamic soil model is used (Taghizadeh-Toosi et al., 2014b) to calculate the soil carbon dynamics in relation to the Danish commitments to UNFCCC. Mineral soils are defined as soils having < 6 % OC in the topsoil (0-30 cm). The outcome from C-TOOL is reported under cropland, although it also includes grassland. Mineral soils in grassland is therefore reported as ‘Included Elsewhere’ (IE). No change in the carbon stock in soils under perennial wooden plants, hedgerows and “Other agricultural cropland” is expected and therefore reported as ‘Not Occurring’ (NO). These areas are also only a minor part of the cropland area. For agricultural crops, C-TOOL is run on a regional level with different soil types with initialization in 1980.

C-TOOL

C-TOOL (Taghizadeh-Toosi et al., 2014b) is a 3-pooled dynamic model, where the approximate average half-live times for the three different pools, Fresh organic matter (FOM), Humified organic matter (HUM) and ROM (Resilient Organic Matter) are 0.6-0.7 years ($k_{FOM} = 1.44 \text{ yr}^{-1}$), 30 years ($k_{HUM} = 0.0336 \pm 0.002 \text{ yr}^{-1}$), and 600-800 years ($k_{ROM} = 4.63 \times 10^{-4} \text{ yr}^{-1}$), respectively. When setting up the model, k_{FOM} and k_{ROM} is taken from short-term and long-term field experiments and based on these static parameters is k_{HUM} estimated with the long-term field experiments to $0.0336 \pm 0.002 \text{ yr}^{-1}$. (Taghizadeh-Toosi, A., 2015).

The main part of biomass returned to soil each year is in the first and easiest degradable FOM pool. This pool consists of mainly fresh straw, fresh manure, root residues, fungi and small animals and fluctuates very much between years depending on the harvest yield and climatic conditions. The FOM pool accounts for approximately 1-2 % of the total carbon stock in the upper 0 - 100 cm. The ROM pool is the most resilient part of the soil organic carbon. In most “old” soils, which has been cultured for hundreds of years it approximate around 50 % of the organic soil carbon (0-100 cm). The remaining amount of organic carbon is allocated to the HUM pool.

However, there is a difference to coarse sandy soils, which is old heathland in Jutland. In 1200-1800 of these, sandy soils were heavily overgrazed and turned into marginal heathland giving a low but very stable carbon content. Since the 1870’s, this land has been cultivated, more farmed cattle were introduced and from the 1950’s fertilized with mineral fertilizer. For these areas, our results show that the amount of HUM is much lower here, 29.0 t HUM ha

¹, compared to the other soil types, which have an average of 49.4 t HUM ha⁻¹ (Table 6.17).

Table 6.17 Estimated amount of HUM and ROM in Jutland and on the Danish Islands.

Location	Total, t C/ha (0-100 cm)	
	HUM	ROM
Coarse Sand, Jutland	29.0	93.4
Loamy Sand, Jutland	42.2	80.4
Sandy Loam, Jutland	57.8	75.7
Loamy Sand, Islands	44.1	63.1
Sandy Loam, Islands	53.4	67.2
Average Loamy Sand and Sandy Loam	49.4	71.6

It is obvious that the ROM pool has a minor influence on the annual C stock changes because it reacts slowly. The FOM has a very large influence because in Denmark the process of turning organic matter (OM) from crop residues into soil organic matter (SOM) starts after harvest from August to October. If there is a large input of crop residues (CR) and low temperatures during autumn, the outcome from the modelling by 31 December of the reporting year, is that only a small amount of the applied CR has been degraded out of the approximate 3.5-5 tonnes C per ha, which is incorporated every year. The result is a rather high total content of SOM at the end of the year and the changes between two successive years are large, if the previous year showed the opposite pattern with a low crop yield and a high temperature in the autumn. Such changes can be seen as “artefacts” as it is a matter of definition of the organic matter, whether it is partly degraded as crop residues or SOM. Therefore, we have agreed with a previous ERT ([ARR 2011](#)) to exclude FOM from the reporting in soils and only include the HUM and ROM pools. As a result, the HUM pool is more or less solely responsible for the changes in the SOC stock between years.

In the case of the sandy heathland in Jutland, the low amount of HUM means that these soils will store higher amounts of C in the future than the other soil types, until it reach the equilibrium state between incorporation and degradation. The history of heathlands C stock can be explained as small annual inputs for hundreds of year has given a higher distribution ROM compared to soils that are more fertile and a low share of HUM. Furthermore, we find large amounts of inert C (partly degraded OM) comparable compared to the other soil types, which we assume is due to burning of the heathland for hundreds of years (biochar). In the case with the old heathland, the annual input of CR has increased tremendously due to cultivation and fertilization. In factual terms, the average Danish cereal yield has doubled from 1900 to 1965 - but on sandy soils, it has quadrupled from a very low level (Statistics Denmark, annual year book). The consequence of this is that these sandy soils haven not reached their equilibrium state yet and are still increasing the SOC. This in contradiction to the old fertile clay soils, which are more in their equilibrium state, although still increasing their C stock due to increased annual CR input.

A simple diagram of C-TOOL is shown in Figure 6.5. C-TOOL is parameterised and validated against long-term field experiments (100-150 years) conducted in Denmark, the United Kingdom (Rothamsted) and Sweden and is “State-of-the-art”. All dynamic models are allocating the total soil carbon stock into sub-compartments each having different degradation times. This distribution cannot be measured but have to be estimated from long-term ex-

periments. As the models are parameterised on mineral soils the model cannot be used on soils having higher carbon contents such as organic soils as there is a limited number of data for validation and that the large amount of easily degradable OC in the organic soils affect the distribution in the different sub-pools. Therefore C-TOOL only used on soils having < 6 % OC. For soils having ≥ 6 % OC is used fixed emission factors per ha. In the inventory has soils having 6-12 % OC been given an emission factor of 50 % of organic soils > 12 % OC.

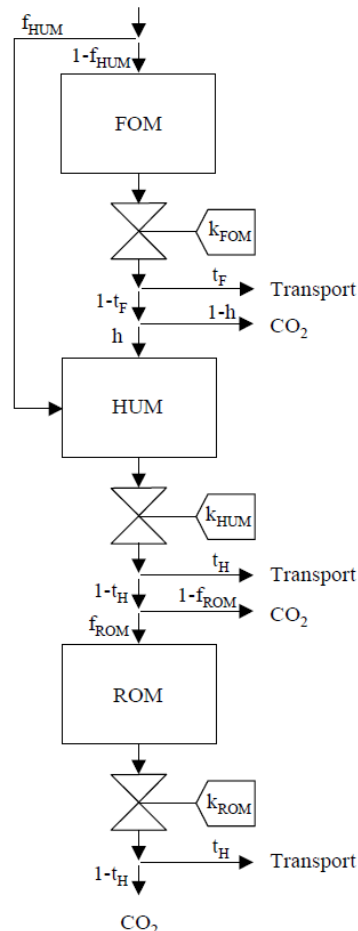

Figure 6.5 A simple diagram of C-TOOL.

Input data to C-TOOL and output

A major revision of the soil parameters was made in 2016. The new version (Version 2.3) was implemented in the 2017 submission for all years. Version 2.3 includes ALL agricultural mineral soils in cropland and grassland. In the modelling, Denmark is subdivided into eight counties. Each county are further subdivided into two or three soil types. On the islands, where the soils typical are loamy sand or loam, two different soil types are used. Jutland, which has a large area with sandy wash-out plains, are split into three different soil types. As C-TOOL treats all agricultural crops on mineral soils including within grassland the emission from grassland is reported as IE as these carbon stock changes are included under cropland. This is also to facilitate the trivial annual conversions from cropland to grassland and vice versa as mentioned in the Land use matrix (Table 6.4). Set-a-side is treated as a separate crop type in C-TOOL with a low input of organic matter similar to unfertilized permanent grass.

As carbon input to each region for each year is taken the actual crop area from the LPIS system and crop yields from Statistics Denmark (www.dst.dk Table

AFG, AFG07, HST7 and HST77). The dry matter content depends on the actual crop. For cereals, it is 15 % (DST, 2021). The amount of agricultural residues returned to soil is the amount estimated by Statistics Denmark (www.dst.dk Table HALM and HALM1). The dry matter content depends on the actual crop. For cereal straw, it is 15 % (DST, 2021).

The amount of animal manure produced (Volatile Substance) and applied to soil is estimated with the same methodology as in the Agricultural sector for estimating CH₄ and N₂O emission where annually updated feeding and excreting data are provided for the regulation of the animal production in Denmark. Here detailed data on the number of animal, housing and manure type are available on farm level. As the animals are distributed unevenly over the country, data on the actual location of each farm and their herd/nitrogen excretion in the Danish mandatory nitrogen accounting system is used as proxy for the distribution of the animal manure on regions and soil types. From 2000, each farm has been geocoded on regions and soil type and multiplied with the animal units on the farm. For the years 1980 to 1999, the same distribution is used as in year 2000.

Since 1997, there has been a requirement for growing N catch crops in Denmark in order to reduce N-leaching. Besides reducing the N leaching, the catch crops increase the carbon stock in the soil. Since year 2000, the area has increased and in 2020 there were 505 000 ha where catch crops were included - often after green maize for fodder or after spring cereals. The requirement for catch crops has altered the way of farming in two ways. Cattle farmers are typically sowing grass seed in their normal cereal fields. This new grass sward must not be ploughed into the soil before winter/next spring. For farmers growing grass seed, which is common in Denmark, the old grass seed fields are not ploughed in to the soil before next spring, in contradiction to the current situation where it would be ploughed early autumn and act as a carbon sink. Eriksen et al. (2014) have estimated that the mandatory catch crops expects to increase the amount of C returned to soil by 0.27 tonnes carbon ha⁻¹ yr⁻¹. The area with catch crops in each region is estimated from each farms' obligatory reporting to the Danish Agricultural Agency on which field each catch crops is grown, which is available for the inventory (LBST, 2021). As for the distribution of animal manure, the area with catch crops have been geocoded since 2000 and the organic matter input has been allocated to the different soil types.

More detailed figures on the distribution as an example of the crop yield and areas are given in Annex 3E, Table 3.E10-12.

C-TOOL is initiated with data from 1980. Actual regional monthly average temperatures are used as temperature driver. The main drivers in the degradation of soil biomass are temperature and humidity. The Danish climate is quite humid with winter temperatures around zero degrees Celsius and hence the importance of soil humidity on the model outcome is low in comparison to temperature, which has a high effect on the emission. As mentioned, when biomass is returned to the soil the major part of it is quite easily degradable. Warm winters with unfrozen soils in connection with high inputs of biomass will therefore, as a result, give high emissions from the soil compared to more cold years, which will give low emissions. The variation in the input to C-TOOL results inter-annual variation in the carbon input to the soil for all years. Combined with inter-annual differences in the temperature, this creates inter-annual differences in the net carbon stock change in mineral soils, where

low yields combined with high temperatures, reduce the total amount of carbon in agricultural soils. The opposite situation, when the combination of high yield and low temperatures, leads to an increase of the carbon stock in soils.

Figure 6.6 shows the total SOC included in the model and Figure 6.7 shows the annual changes. The blue line represents all three pools (FOM, HUM and ROM) and the red line represents only HUM and ROM. It is obvious, that the total carbon stock fluctuates more than the two more steady pools, HUM and ROM. 2017 was a good year for growing cereals giving high yields compared to 2016. For 2018, the yields were very low due to a severe drought in the growing season. Consequently, an increase in the overall SOC stock compared to 2016 is seen and a large decrease from 2017 to 2018 (Figure 6.6). In 2019 and 2020 the crop yields were back to normal.

Two examples

Both year 2006 and 2007 were bad cropping years with cereal crop yields of 7-9 % below the average of 2001-2010. The average Danish temperature was, however, 1.9 °C higher than the reference for 1961-1990 in 2007. Therefore, both due to the low C input and a high degradation rate, the agricultural soils were estimated to have a high loss of carbon in these years, cf. Figure 6.6 and 6.7.

In recent years (1999 - 2020), Denmark has experienced very warm winters, except from 2010, which was very cold and below the average from 1961 to 1990. Year 2010 had an average of 7.0 °C against the normal of 7.7 °C. This means that the degradation goes down. The average cereal yield was 3.5 % lower than the average of 2001-2010. The result was an increased carbon stock in the soil.

In 18 out of the last 20 years, the annual average temperature has been above the average temperature from 1961 to 1990. Year 2020 had an average temperature of 9.8 °C or 2.1 °C above the average from 1961 to 1990.

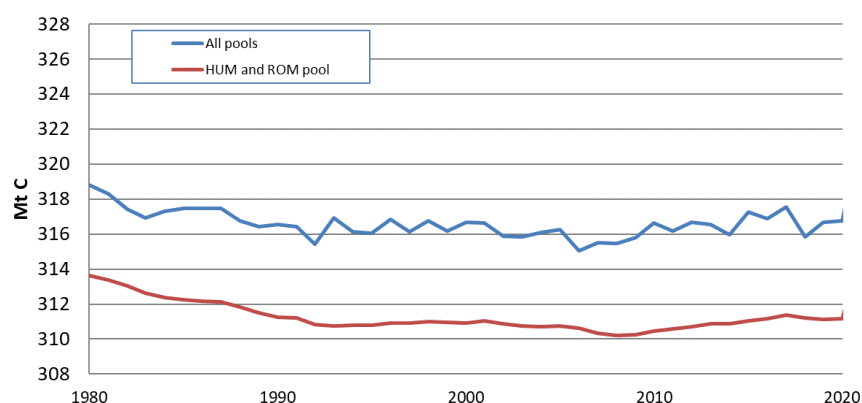

Figure 6.6 The development in the C-stock in agricultural soils, 1980-2020, Mt C (million tonnes C).

As a whole, the modelled emissions are found to be the most reliable emission estimates reflecting the Danish conditions. As described in the agricultural sector, the Danish farmers have faced increased demands for lower environmental impact since the mid-1980s. The general effect on the carbon stock in soil is that during the 1980s shows a decrease in the carbon stock, while during the 1990s, the carbon stock seemed to stabilise due to the higher input of organic matter. Taking into account the lesser agricultural area and the in-

creased global temperatures, a steady total carbon stock was modelled between 2000 and 2010, while the total SOC increase after 2010. Since 1990, C-TOOL has estimated a decline of 0.04 % of the total SOC in the mineral agricultural soils (average 1988-1992 to average 2016-2020). No precise uncertainty calculation has been made. However, it is assumed that the uncertainty of the annual loss/ gain is around 25 %. Denmark has very good data on harvest yields and cultivated area data, which indicate a low uncertainty.

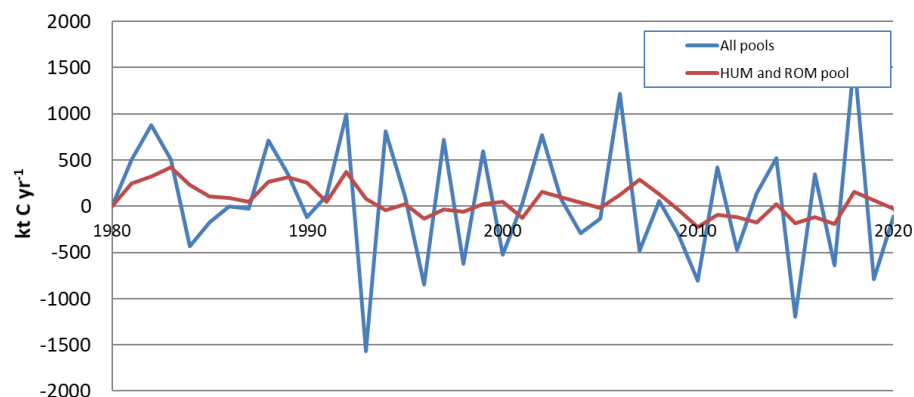

Figure 6.7 Estimated annual emissions from mineral soils 1981 to 2020 (kilo tonnes CO₂ yr⁻¹).

Verification of C-TOOL

C-TOOL is partly parameterised with data from the Danish Agricultural soil sampling grid. The grid was established in 1987 in a 7 x 7 km² grid. In 1987, > 600 agricultural plots were sampled and analysed for carbon. Half of the grid were resampled in 1998 and a full resampling of 464 plots was made in 2008/2009. Figure 6.8 shows the development of the carbon stock in 0-100 cm depth in the paired plots, which indicate an increase for the soil C stock at the sandy soils (Coarse Sand, Fine Sand and Loamy Sand). This is mainly due to increase of the crop yields, which increase the amount of organic matter returned to soil. Furthermore, the Danish cattle herd is located on the sandy soils and typically have large areas with grass in rotation. This favours the soil C stock. Contrary to this, a loss in the C stock on the loamy soils (Sandy Loam and Loam) is observed. On the loamy soils, annual crops are the most common cultivars and usually have a limited number of cattle and pigs. The measurements uncertainty is high, so overall it is concluded that the modelled results are in line what is found in plot sampling.

As C-TOOL is partly parameterised with the development in the soil sampling grid, the model output will mimic the measured development in the soil carbon stock in mineral soils. The variation in measured carbon stock in paired soil samples in the soil sampling grid is high. The conclusion is that the modelled outcome from C-TOOL represents a proper value for the development of the carbon stock in the Danish agricultural soils. A new sampling in the grid was made in 2018/2019. The data has not been analysed yet. This will further verify the development.

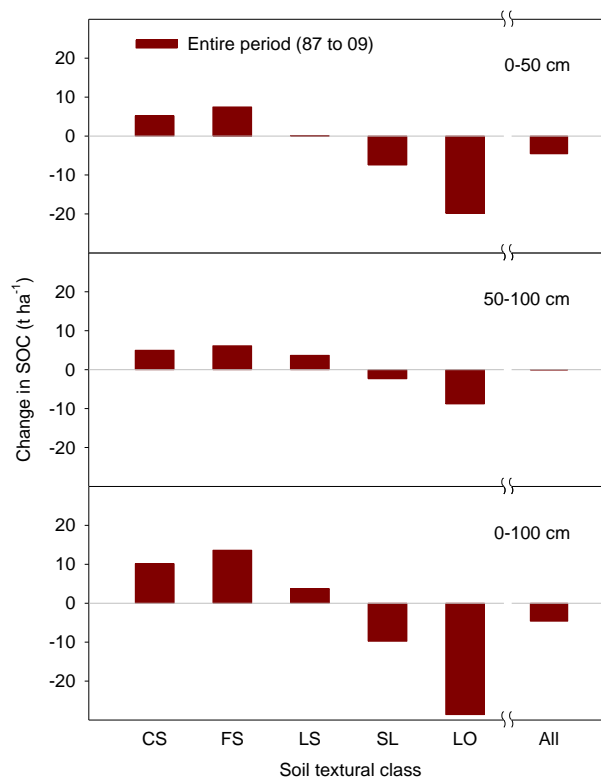

Figure 6.8 The change in carbon stock in soil (0 - 100 cm) in >460 paired agricultural plots from 1987 to 2009 (Taghizadeh-Toosi et al., 2014a).

Organic soils - 4B1

The basic Danish soil classification system from 1975 (Arealklassifikationen, 1975) has a definition for organic soils as having $\geq 10\%$ organic matter (OM) in the topsoil, equivalent to 6% OC. In 2010, a new soil map of the organic soils was made for the inventory based on the definition in the IPCC guidelines (Greve et al., 2014), i.e. 20% OM (Figure 6.9). The soil map is a statistical map based on >10 000 soil samples down to the mineral soil in 30 cm intervals combined with a very detailed digital elevation map (DEM) for each 1.6×1.6 m² covering the entire Denmark, water table maps and other old maps with organic soils. The definition of an organic soil in the map is 20% organic matter with a depth of minimum 30 cm (Greve et al., 2014). The total area with organic soils in the area covered by the soil map has been estimated to 298 000 ha. In 2010, 177 135 ha of the organic area was included in the farmers Land Parcel Information System.

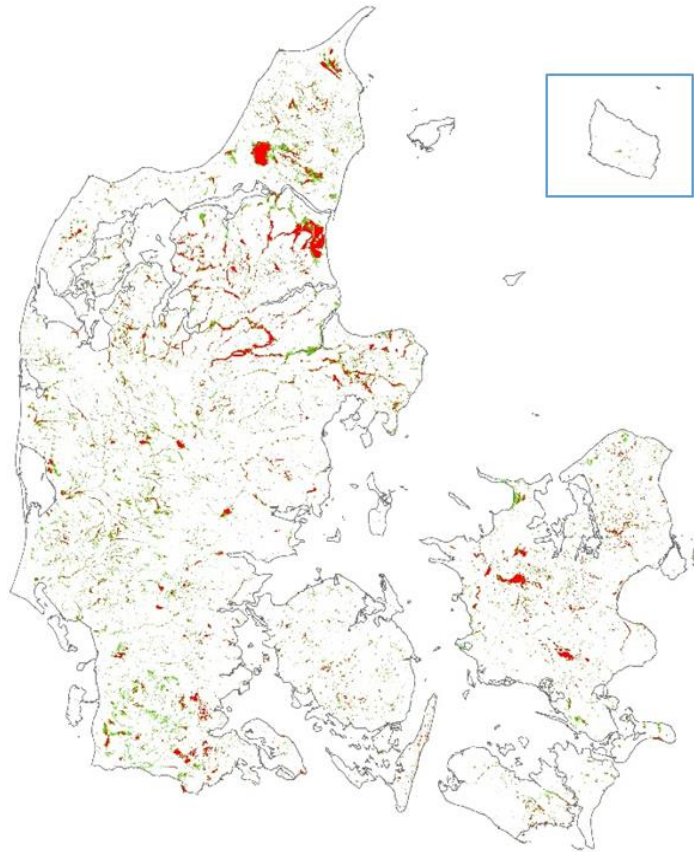

Figure 6.9 The organic soil map for Denmark for year 2010, > 6 % OC (Greve et al., 2014). Green colour indicate 6-12 % OC and red colour indicate >12 % OC soils.

To estimate the actual land use of organic soils, a digital map field map has been placed on top of the organic soil map. The digital field map include all agricultural fields in Denmark (>570 000 fields). This map from the EU subsidiary system is precisely mapped with an uncertainty down to $< \pm 0.5$ meter. The actual grown crop is known for each field. In total, more than 270 different crop types or combination of crop and crop management are recorded. In 2020, 89 055 hectares with annual crops and 79 922 with perennial grass were located to be grown on the organic soil area in the defined CL with ≥ 6 % OC. Every year we can see that some areas are falling out of the field map. Areas where the farmers are not applying for subsidies. Some of these are found in the map for Wetlands (4.D), but not all of them. In 2020, 1 864 hectares could not be recognized. Further drainage of the organic soils in Denmark has not been allowed for many years. The most likely situation is that these areas have become wet and not suitable for cropping purposes. These areas has been assigned an emission of 3.6 tonnes C per ha as for shallow-drained nutrient-rich grassland from the 2013 Wetland Supplement (IPCC 2014).

The previous Danish soil classification carried out in 1975, estimated that there were 243 000 hectares of organic soils in agricultural land (≥ 6 % C). Of these were 176 124 ha in the Cropland and the remaining 66 875 ha were with grass. In 2010 we only could find 180 000 ha. The major reason for the drastic reduction is that Denmark is quite flat with shallow organic layers, which combined with intensive agricultural utilisation with high drainage rates has oxidized a major part of the organic matter.

Emission factors for organic soils

An intensive research programme has been carried out to monitor the CO₂ emission from three organic soils in Denmark with annual crops in rotation and permanent fertilized grassland (Elsgaard et al., 2012). The overall result is shown in Table 6.18 compared with the IPCC default values. For areas not reported in the land field system, default Tier 1 emission factors from the 2013 Wetland Supplement (IPCC 2014) are used. Maljanen et al. (2010) recently reviewed the GHG balance of managed organic peatlands in the Nordic countries. For areas with agricultural grasslands, the available studies suggested a net CO₂ emission of $4.9 \pm 3.2 \text{ t C m}^{-2} \text{ yr}^{-1}$ (mean +/- standard deviation, n = 4). The available studies (n = 4) represented three Finnish and one Norwegian site (Lohila et al., 2004; Maljanen et al., 2001, 2004; Grønlund et al., 2008). The up-scaled annual emission from the Danish declining carbon stock is in line with these figures when taking into account the differences in temperatures. Considering that the IPCC estimate also covers the boreal zone, the measured Danish values seems to be in line with the IPCC guidelines. Emissions from organic soils on permanent grassland are reported under Grassland (CRF Table 4.C.1). The emission factors are given in Table 6.18.

The dominating use of the organic soils is fertilised annual crops and grass in rotation. As C-TOOL has shown not to be able to simulate the emissions from soils having >6 % OC, fixed emission factors have been used for this area. No data has been found in the literature as it does not qualify as organic in the scientific world and hence little attention has been paid to these soils. Normally, mineral soils in equilibrium will have an organic matter of 1-1.5 % OC. Soils having higher contents are most likely developed under humid conditions with low degradation rates. Drained and managed soils having >= 6-12 % OC can therefore not be seen as being in their equilibrium state and will evidently lose carbon. It has therefore been decided to allocate an emission of 50 % of what was measured for soils > 12 % OC in an attempt to account for these losses. These emissions are included in 4B and 4C.

Table 6.18 Emission factors from organic soils, tonnes C per ha per year.

	Cropland Annual crops and grass in rotation	Grassland		Abandoned land	
		Permanent grass		C, tonne yr ⁻¹	CH ₄ , kg yr ⁻¹
		C, tonne yr ⁻¹	CH ₄ , kg yr ⁻¹		
Soils > 12 % OC	11.5 (SE = ±2.0)	8.4 (SE = ±1.0)	16	3.6	39
Soils 6-12 % OC	5.75	4.2	8	1.8	19.5
IPCC 2014, Bo- real and Tem- perate	7.9 (CI = 6.5-9.4)	3.8-6.1 (CI = 5.0- 7.3)	16	Grassland shallow drained 3.6 (CI = 1.8-5.4)	39

As emission factor for N₂O from the 2013 Wetland Supplement, the default value of 13 kg N₂O-N per ha per year is used for the area with > 12 % OC. This emission is reported in the agricultural sector, 3Da6 (cultivation of organic soils). No CH₄ emission is reported from drained CL except for CH₄ from ditches, with default values from the 2013 Wetland Supplement (IPCC, 2014); although for the shallow-drained abandoned organic soils a CH₄ emission factor of 39 kg CH₄ ha⁻¹ yr⁻¹ for soils with >12 % OC and 19.5 CH₄ ha⁻¹ yr⁻¹ for soils with 6-12 % OC are reported.

To estimate the emission from the organic soils, a linear decrease in the area with organic soils between 1975 and 2010 has been assumed. All CO₂ emissions from organic soils converted from other land use categories to cropland are reported under 4.B.1 and not under the respective land use conversion classes 4.B.2.1 to 4.B.2.5. The related N₂O emission is reported in the agricultural sector in CRF Table 3.Da5.

The total CO₂ emissions from the organic soils in cropland are given in Table 6.19.

Table 6.19 Emissions from cropland organic soils 1990 to 2020.

	1990	2000	2010	2015	2016	2017	2018	2019	2020
Cropland, 6-12 % OC, ha	79618	74845	69159	64169	63490	63110	61731	61690	60582
Cropland, >= 12 % OC, ha	54082	47851	40718	34980	34209	33802	32498	32754	31790
Cropland, total, ha	133700	122697	109877	99149	97699	96911	94228	94444	92372
Emission, from drained land, kt C	1079.7	980.7	865.9	752.6	739.8	733.0	710.1	713.0	695.2
Emission from leached C, kt C	29.1	26.4	23.3	20.8	20.4	20.3	19.6	19.7	19.2
CH ₄ , kt CH ₄	5.5	5.0	4.4	4.0	3.9	3.9	3.8	3.8	3.7
Emission, total, kt CO ₂	4202.5	3816.8	3370.3	2935.7	2885.8	2859.4	2770.4	2781.6	2712.3

6.3.8 Uncertainties and time series consistency

A Tier 1 uncertainty analysis has been made for part of the LULUCF sector cf. Table 6.20. The uncertainty in the activity data for the agricultural sector is very low. The highest uncertainty is associated with the emission factors. Especially the emission/sink from mineral soils and organic soils has a high influence on the overall uncertainty.

The LULUCF sector contributes to a large extent to the total estimated uncertainty. In recognition of the difficulties in analyses of uncertainty, the estimated uptake of CO₂ in the forestry sector must be treated with caution.

Table 6.20 Tier 1 uncertainty analysis for Cropland for 2020.

	1990		2020		Activity data, %	Emission factor, %	Combined uncertainty	Total, Uncertainty, 95 %, kt CO ₂ eqv.	
	Emission/sink, kt CO ₂ eqv.	Emission/sink, kt CO ₂ eqv.	Emission/sink, kt CO ₂ eqv.	Emission/sink, kt CO ₂ eqv.				uncertainty, %	95 %, kt CO ₂ eqv.
4.B Cropland	5297.9	2851.0					43.2	1230.3	
4.B.1 Cropland remaining cropland, Living biomass	CO ₂	74.6	154.9	3	15	15.2	15.2	23.6	
4.B.1 Cropland remaining cropland, Mineral soils	CO ₂	932.2	-109.5	3	75	75.0	75.0	82.2	
4.B.1 Cropland remaining cropland, Organic soils	CO ₂	3959.1	2549.0	3	50	50.1	50.1	1277.3	
4.B.2 Forest land converted to cropland	CO ₂	2.2	119.4	10	50	51.0	51.0	60.9	
4.B.2 Other land uses converted to cropland	CO ₂	86.3	-31.6	10	50	51.0	51.0	16.1	
4(II) Cropland on organic soils	CO ₂	106.7	70.6	3	40	40.1	40.1	28.3	
4(III) Mineralization/immobilization, Cropland	N ₂ O	0.1	5.6	10	50	51.0	51.0	2.8	
4(II) Cropland on organic soils	CH ₄	137	92.7	10	90	90.6	1241.2	0.1	

The time series are complete.

6.3.9 QA/QC and verification

A general QA/QC plan is developed for Cropland. The following Points of Measures (PM) are taken into account.

- Collection and error check on in-data
- Control of sums
- Comparison with other data.

The area estimates for Cropland and Grassland since 2010 are very precise due to unrestricted access to detailed data from EUs Integrated Administration and Control System (IACS) on agricultural crops on field level and the use of the vector based Land Parcel Information System (LPIS). This access includes both Statistics Denmark and DCE. The total uncertainty in the major crop data is estimated by Statistics Denmark to be <2 %. Together with detailed soil maps, this gives a unique possibility to estimate the agricultural crops on different soil types and hence track changes in land use. However, IACS and LPIS are only available from 1998 and onwards, and estimates for 1990 are therefore more uncertain. The QA of crop data is made by Statistics Denmark.

Data on newly planted and removed hedgerows are based on subsidised hedgerows and QA is carried out by the Danish Agricultural Agency, who is responsible for the administration of the subsidy scheme. The uncertainty in the number of plants used for the hedgerows is not estimated but is assumed very low because of the subsidy system.

There is an unknown uncertainty in the number of un-registered removals of hedgerows. A linear approach has therefore been made for “missing” hedges over the years. Establishment of wetlands is based on vector maps received from every county in Denmark. The uncertainty is not estimated but assumed very low due to the subsidised system.

As shown in Figure 6.7 and 6.8, the increase in carbon stock as estimated by C-TOOL seems close to the results from 464 paired soil samples.

A range of experts from the Faculty of Agricultural Sciences, Aarhus University, are repeatedly involved in discussions and report writings on topics related to the inventory.

6.3.10 Recalculations, including changes made in response to the review process

An error were found in the cereal/straw relation for winter wheat. The error overestimated the amount of wheat straw and thus the annual C input from biomass to the soils in the modelling. The consequence of lowering the C input, mainly the loamy soils where wheat is grown, is that the soils are turned into sources where it is difficult to maintain the current C stock. The overall effect is a larger emissions for all years. This change has been implemented for all years.

A minor redistribution of the area with new hedges between 2018 and 2019 has been made.

6.3.11 Planned improvements

A 1.2 million € project has been started in 2021 to investigate the emissions from the organic soils. This project includes a detailed modelling/mapping of the groundwater level in drained organic agricultural soils. Resampling of > 1000 organic soils within the organic soil map from 2010 and based changes

in the peat layer develop new degradation model. It is expected that the results is ready for implementation in the 2024 submission.

6.3.12 Land converted to cropland (4B2)

Agriculture covers more than 63 % of the total area giving a large impact on the environment. As a consequence, there are many initiatives to transfer agricultural land into natural habitats and forest, and the continuous development of infrastructure demands more land. Land converted to cropland is therefore not an issue. The largest challenge is that the farmers in one year may report that a certain field is cropland and the next year is permanent grassland where it could stay for several years before it again is ploughed and turned into annual cropland for one year. Despite or rather because of the detailed information, which is available, is it impossible to have a conservative land use transition between these two land use categories. To avoid large conversion ratios between cropland and grassland, a rule has been set up, where cropland and grassland (in the farmers reporting system) has been in the same category for five years before land use conversion in the LUM takes place. The annual change is between 2000-6000 ha. However, as the carbon stock changes in mineral soils are estimated with C-TOOL combined for cropland and grassland, the effect of this has no impact on the overall emission estimate from agricultural soils.

Approaches used for representing land

The area converted from other land use to Cropland is based on remote sensing of the Danish area in 1990, 2005, 2011, 2012-2020 combined with data in LPIS on which crops are grown in each field.

Methodological issues

Change in carbon stock in living biomass

For land converted to cropland, a standard default gain value of 9 577 kg DM (dry matter) per hectare in above ground biomass and 2 298 kg DM per hectare in below ground biomass is used. This value is equivalent to the average harvest of living biomass for all cereals grown in Denmark from 2001 to 2010, including straw, stubble and glumes. For conversion from DM to carbon, a default fraction of 0.5 kg C per kg DM is used (Table 6.12).

For conversion from cropland to other land use categories, the same value is used but recorded as a loss of carbon in the respective category (4A2, 4C2, 4D2 and 4E2).

The loss in living biomass for conversion from another land use category into CL is estimated as the default value for DM in that particular land use category. I.e. for deforested areas, the average carbon stock per hectare for all deforested areas is used.

Change in carbon stock in dead organic matter

When forest is converted to cropland, it is assumed that all dead organic matter will have an instant oxidation. The actual amount depends on which type of forest is converted. Due to current harvest practises (chipping), no significant amount of dead organic matter is left on site. Based on the NFI measurements of O-horizon thickness, default bulk density values and a C:N ratio of 22 (Vejre et al., 2003) an average emission factor of 5.1 kg N₂O-N per ha is used.

Conversion from other categories is assumed as not occurring, as no dead organic matter is reported for these categories.

Change in carbon stock in soils

The actual amount depends on which type of land it is converted from (see Table 6.12). To reach the new equilibrium state, a default transition period of 30 years is used. The default IPCC-value of 20 years seems according to Danish investigations, not to be applicable for Danish conditions.

N₂O emissions for forest land converted to cropland is based on the Tier 2 methodology with the default C stock of 142 t C/ha as given in Table 6.12 and using a C:N value of 22 (Callesen et al., 2007) and an emission factor of 0.01 kg N₂O-N kg N⁻¹ released.

Uncertainties and time series consistency

The time series are complete.

See uncertainties and time series consistency in Section 6.3.1.

QA/QC and verification

See QA/QC and verification in Section 6.3.1.

Recalculation

See recalculation in Section 6.3.1.

Planned improvements

See planned improvements in Section 6.3.1.

6.4 Grassland (4C)

Grassland is defined as the remaining land category after subtracting the areas of settlements, forest, cropland, wetlands and other land from the total land area. As cropland includes all perennial wooden areas such as hedges, shelterbelts, fruit plantations and other wooden areas that do not qualify as forest, no perennial wooden crops is reported in grassland. Thus, grassland consist of heath- scrubland and marginal agricultural grazed land.

The total area reported under grassland has increased, cf. Table 6.20. The CO₂ emission from mineral soils is reported under cropland except where land use changes has taken place. The increase in the emission from living and dead biomass is mainly due to the land use conversion to and from cropland and should as such not be seen as loss of living biomass. The emission from organic soils has decreased due to a smaller area with grassland on organic soils.

Table 6.20 Total area and annual emissions 1990 to 2020 from Grassland.

Grassland	1990	2000	2010	2015	2016	2017	2018	2019	2020
Area, 1000 ha	132.9	131.3	137.1	166.3	169.1	172.3	169.5	170.7	168.9
Living and dead biomass, kt C	2.7	-0.6	9.8	46.6	49.5	19.2	47.6	28.1	46.5
Mineral soils, kt C	14.4	9.3	4.0	1.2	0.7	0.1	-0.5	-1.0	-1.0
Organic soils, kt C	558.6	502.6	471.6	500.1	506.3	511.7	527.0	523.9	532.2
Total, kt C	575.6	511.3	485.4	547.9	556.5	531.0	574.2	551.0	577.7
CH ₄ , kt CH ₄	4.76	4.28	4.02	4.26	4.32	4.36	4.49	4.47	4.54
N ₂ O, kt N ₂ O	0.000	0.000	0.001	0.008	0.002	0.000	0.003	0.000	0.001
Total, kt CO ₂ eqv.	2229.7	1982.0	1880.7	2117.8	2148.9	2055.9	2218.5	2132.0	2231.9

6.4.1 Grassland remaining grassland (4C1)

Denmark is an intensive agricultural country with small holders and small fields where cropland and grassland is mixed together making it difficult to distinguish between dedicated cropland and dedicated grassland. According to the Danish Land Parcel Information System (LPIS), there are approx. 175 000 fields of total 310 000 ha with permanent grassland in 2020 giving an average size of two ha. Some of them cannot be regarded as permanent grassland and are therefore included in cropland.

6.4.2 Grassland area

The total area with grassland has been estimated in the Land Use Matrix. In 1990, the total area was 146 388 hectares and in 2020 the area had increased to 168 917. This is quite a small area, but here it should be taken into account the uncertainty to accurately report the area with grassland and cropland. According to Statistics Denmark, there are 235 000 ha of permanent GL, cf. Table 6.14. This means that part of what is reported by Statistics Denmark here, are reported under CL. As C-stock changes in the mineral soils are modelled as a whole with C-TOOL the allocation between cropland and grassland has no effect on the emission estimates.

6.4.3 Grassland definition

Grassland is split into grazing grassland and other grassland. Grazing grassland is the area with permanent grassland as recorded by Statistics Denmark. Other grassland is the difference between the grassland area in the land use matrix and the area reported by Statistics Denmark.

6.4.4 Methodological issues for grassland

The area for grazing grassland is the area reported by statistics Denmark and the rest of the grassland is the residual part of the grassland area. The area with organic soils in grassland is estimated from the new organic soil map with an overlay of the fields where the farmers are reporting agricultural crops. Permanent grass fields receiving <25 kg N per ha per year is reported under grassland. If the farmers are reporting permanent grassland but are using >25 kg N per ha per year, it is assumed that this field is grass in rotation because of the fertilization level.

6.4.5 Change in carbon stock in living biomass

No changes in living biomass are assumed for grassland remaining grassland, except for a minor conversion between "Grazing land" and "Other grassland". However, the sector grassland remaining grassland is showing a loss in carbon stock due to a high inter-annual land use conversion. This has some effect on the inventory, but limited as a whole, as the estimated loss can be found under the land use category, to which grassland is converted.

6.4.6 Change in carbon stock in dead organic matter

No changes in dead organic matter are estimated, as this is not occurring for this category.

6.4.7 Change in carbon stock in soils

No changes in the carbon stock in GL mineral soils is reported for grassland, which can be seen as purely uncultivated grassland. For grassland, which is part of the agricultural area, the emission is included under cropland and

therefore reported as 'Included Elsewhere' (IE) under grassland. For organic soils, a nationally developed emission factor of 8 400 kg C per ha per year is used for soils with at least 12 % OC (Elsgaard et al., 2012). For organic soils having 6-12 % OC is used an emission of 4200 kg C per ha per year. As the reported area with organic soils has decreased over time, the overall emission from grassland has gone down too, including CH₄. Since 2010, there has been a marginalisation of cropland to grassland increasing the reported area with grass, increasing the emission of CO₂ and CH₄ from grassland over the latest years, Table 6.22.

Table 6.22 CO₂ emissions from drained Grassland organic soils 1990 to 2020.

	1990	2000	2010	2015	2016	2017	2018	2019	2020
Grassland, 6-12 % OC, ha	34922	32829	32839	35240	35684	35923	37106	36980	37649
Grassland, >= 12 % OC, ha	46668	41292	37720	39796	40286	40787	41956	41658	42273
Grassland, total, ha	81590	74120	70559	75036	75970	76709	79063	78638	79922
Emission, drained land, kt C	538.7	484.7	454.8	482.3	488.3	493.5	508.3	505.2	513.2
Emission from leached C, kt C	19.9	17.9	16.8	17.8	18.0	18.2	18.8	18.6	18.9
CH ₄ , kt CH ₄	4.8	4.3	4.0	4.3	4.3	4.4	4.5	4.5	4.5
Emission, total, kt CO ₂	2167.1	1950.1	1829.5	1940.2	1964.3	1985.3	2044.8	2032.6	2064.7

In agriculture, CRF Table 3D, N₂O emissions from both Cropland and Grassland are reported.

6.4.8 Uncertainties and time series consistency

Uncertainty estimates are given in Table 6.23.

Table 6.23 Tier 1 uncertainty analysis for Grassland for 2020.

		1990	2020				Total, Uncertainty,	
		Emission/ sink, kt CO ₂ eqv.	Emission/ sink, kt CO ₂ eqv.	Activity data, %	Emission factor, %	Combined uncertainty	uncertainty, % kt CO ₂ eqv.	95 %, %
4.C Grassland		2229.7	2231.9				43.7	975.1
4.C.1 Grassland remaining grass- land, Living biomass	CO ₂	7.5	130.1	3	7	7.4	7.4	9.7
4.C.1 Grassland remaining grass- land, Organic soils	CO ₂	1974.2	1873.8	3	50	50.1	50.1	939.0
4.C.2 Forest land converted to grassland		2.4	14.7	10	50	51.0	51.0	7.5
4.C.2 Other land uses converted to grassland	CO ₂	53.7	30.2	10	50	51.0	51.0	15.4
4(II) Grassland on organic soils	CO ₂	72.9	69.4	3	40	40.1	40.1	27.9
4(II) Grassland on organic soils	CH ₄	119.0	113.4	10	90	90.6	90.6	102.7
4(V) Biomass Burning	CH ₄	0.002	0.001	10	30	31.6	31.6	0.000
4(V) Biomass burning	N ₂ O	0.002	0.001	10	30	31.6	31.6	0.000
4(III) Mineralization/immobilization, Grassland	N ₂ O	0.005	0.162	10	90	90.6	90.6	0.147

The time series are complete.

6.4.9 QA/QC and verification

See QA/QC and verification in Section 6.3.

6.4.10 Recalculations

No recalculations has been made.

6.4.11 Planned improvements

In the coming years we will look further on the emission factors from organic soils used in grassland.

6.4.12 Land converted to grassland (4C2)

As agriculture covers more than 63 % of the land area, and in order to reduce the environmental impact, there is a strategy for turning cropland into grassland or forest; and where deforestation takes place, it is often turned into grassland, settlements or wetland.

Approaches used for representing land

The area converted from other land uses to grassland is based on use of Land Parcel Information data, Natura 2000 vector layers, other vector maps and remote sensing of the Danish area in 1990, 2005, 2011 combined with field maps from 2011-2020. Areas used for gravel digging are normally converted to grassland because the normal procedure is removal of the topsoil, and then gravel digging. After having finished the gravel digging the topsoil is reversed to the land and the area turned into marginal grassland/recreational area. To avoid too many land conversions, gravel digging areas are converted directly from cropland to grassland instead of cropland to settlement to grassland. As an example with an open gravel pit and a restored area, please see: [Hedeland resort](#).

Methodological issues

Change in carbon stock in living biomass

For land converted to "grazing land", a standard default gain value of 2 400 kg DM (dry matter) per hectare in above-ground biomass (IPCC 2006, Table 6.4) and 6 720 kg DM per hectare in below-ground biomass (IPCC 2006, Table 6.1) is used. For "Other grassland" not purely free of wooden trees/bushes, it is assumed that there is a living biomass of 2 200 kg DM per ha in above ground biomass and 6 160 kg DM per ha in below ground biomass (R:S-factor of 2.8, 2006 IPCC Guideline). For conversion from DM to C, a default fraction of 0.5 kg C per kg DM is used (Table 6.12).

For conversion from grassland to other land use categories, the same values are used, but recorded as a loss of carbon in the respective category (4A2, 4B2, 4D2 and 4E2).

Change in carbon stock in dead organic matter

When forest is converted to grassland, it is assumed that all dead organic matter will be cleared and instant oxidation will take place.

Emissions associated with dead organic matter from conversion from other categories is assumed as NO.

Change in carbon stock in soils

The actual amount depends on which type of land it is converted from (see Table 6.12). To reach the new equilibrium state, a linear approach is used (IPCC 2006). The IPCC default transition period is 20 years. According to Danish investigations, the default IPCC-value of 20 years seems to be not applicable for Danish conditions and 30 years has been used.

Uncertainties and time series consistency

See uncertainties and time series consistency in Section 6.4.1.

6.5 Wetlands (4D)

In Denmark, wetlands include the following subcategories:

- unmanaged fully water covered wetlands (lakes and rivers)
- unmanaged partly water covered wetlands (fens and bogs)
- managed drained land for peat extraction
- managed partly water covered wetlands (re-established wetlands on primarily former cropland and grassland)
- managed fully water covered (new lakes).

6.5.1 Wetlands remaining wetlands (4D1)

In the beginning of 1990, the total area with wetland was estimated to be 103 267 hectares. By the end of 2020, this area has increased to 127 856. Of this, 53 091 ha were lakes and rivers in 1990 - increasing to 59 118 ha by the end of 2020 inside the > 7000 km long coastline, Table 6.24.

Table 6.24 Total area and annual emissions 1990 to 2020 from Wetlands.

Wetlands	1990	2000	2010	2015	2016	2017	2018	2019	2020
Lakes, 1000 ha	53.1	54.4	56.0	57.2	57.2	57.2	57.2	58.3	59.1
Partly water covered, 1000 ha	48.6	51.8	57.1	61.3	62.5	64.0	65.8	66.8	68.0
Peat extraction area, 1000 ha	1.6	1.6	1.6	0.8	0.8	0.8	0.8	0.8	0.8
Wetlands, total, 1000 ha	103.3	107.8	114.7	119.3	120.5	122.1	123.8	125.9	127.9
Managed Wetlands, Living and dead biomass, kt C	0.9	0.9	3.6	1.7	-0.1	-2.4	-0.8	3.9	-0.7
Soil organic matter, Peat extraction, kt C	27.1	18.5	14.2	11.1	11.5	8.3	14.3	8.1	11.6
Total, kt C	28.0	19.4	17.8	12.8	11.4	6.0	13.5	12.0	11.9
CH ₄ , kt CH ₄	0.071	0.256	0.598	0.822	0.907	1.005	1.036	1.076	1.141
N ₂ O, kt N ₂ O	0.001	0.001	0.001	0.000	0.000	0.000	0.000	0.000	0.000
Total, kt CO ₂ eqv.	104.8	77.8	80.4	67.5	64.6	47.1	75.7	71.0	72.3

The land use matrix provides updated figures on the area with partly water covered and fully water covered wetland areas. Partly water covered areas are moors and other areas with raised water table. Fully water covered areas are lakes and rivers.

6.5.2 Wetland area

In the beginning of 1990, the total area with partly covered wetlands remaining wetlands was estimated to be 49 856 hectares. By the end of 2020, the area with partly water covered wetlands remaining wetlands had increased to 68 727 hectares. The total area with peat extraction is about 300 hectares open surface (Larsen, 2014). Based on aerial photos, it is assumed that 800 hectares are affected by drainage in 2020.

6.5.3 Approaches used for representing land areas

The area for wetlands remaining wetlands is primarily based on data from the Danish Geodata Agency and Natura 2000 maps (moors and other natural habitats). The area with peat excavation is a vector map layer made by DCE based on aerial photos of the three excavation sites. The actual three locations are Fuglsø mose on Djursland, Lille Vildmose and Store Vildmose - both in Northern Jutland. All locations are nutrient poor raised bogs.

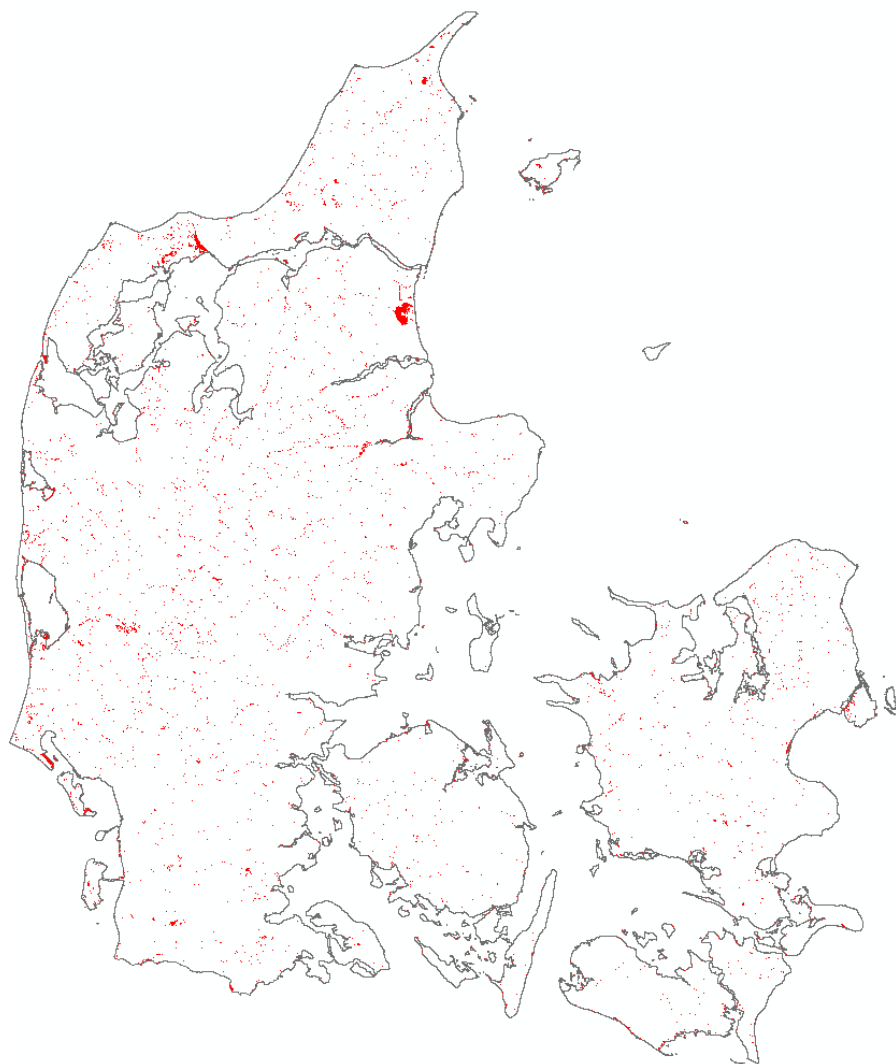

Figure 6.10 Areas with established wetlands and increased water tables in 2019.

6.5.4 Methodological issues for peat extraction areas

Approximately 300 hectares are utilized for peat extraction. It is assumed that 800 hectares are drained and affected by the excavation. The amount of excavated peat is decreasing. In 2017, 107 000 m³ were excavated; due to the very warm summer in 2018 an increased harvest was reported to 213 000 m³, in 2019 103 000 m³ and in 2020 165 000 m³.

6.5.5 Change in carbon stock in living biomass

No changes in living biomass are occurring.

6.5.6 Change in carbon stock in dead organic matter

Dead organic matter is not occurring.

6.5.7 Change in carbon stock in soils

The surface emission from the open peat extraction area is calculated according to Tier 1 from the 2013 Wetlands Supplement (IPCC 2014).

The amount of excavated peat (m³ per year) is for each individual extraction site reported to and published by Statistics Denmark (www.dst.dk, Table RST). The total amount of peat excavated has been reduced from 399 000 m³

in 1990 to 165 000 m³ in 2020. This is a 60 % reduction. For conversion to carbon, a density factor of 200 kg per m³ is used (Larsen, 2014) who is responsible for the majority of the extraction sites. Furthermore, a DM content of 0.5, an ash content of 0.02 and a carbon content of 0.58 kg C per kg OM are applied.

For other areas in wetlands remaining wetlands, no changes are reported.

6.5.8 CH₄ and N₂O emissions

The CH₄ and N₂O emissions from peat land extraction areas are based on the 2013 Wetland Supplement (IPCC 2014).

6.5.9 Recalculation

No recalculation has been made.

Category-specific planned improvements

No improvements are planned.

6.5.10 Methodological issues for flooded land

No emissions are estimated from flooded land.

6.5.11 Methodological issues for partly water covered wetlands

No changes in the carbon stocks and emissions are reported from unmanaged partly water covered wetlands. Only emissions from wetlands established from 1990 and onwards are reported, see Chapter 6.5.2.

6.5.12 Uncertainties and time series consistency

Table 6.25 shows the emission estimates and estimated uncertainties for Wetlands.

Table 6.25 Tier 1 uncertainty analysis for WE remaining WEs and re-established WE for 2020.

		1990	2020	Activity data, %	Emission factor, %	Combined uncertainty	Total, uncertainty, %	Uncertainty, 95 %, Gg CO ₂ eqv.
		Emission/sink, Gg CO ₂ eqv.	Emission/sink, Gg CO ₂ eqv.					
4.D Wetlands		104.8	72.3				51.7	37.3
4.D.1.1 Peat extraction remaining peat extraction	CO ₂	99.5	8.2	10	75	75.7	75.7	6.2
4.D.1.2 Flooded land remaining flooded land	CO ₂	NA	0.0	10	75	75.7	0.0	0.0
4.D.2. Land converted to wetlands	CO ₂	3.2	35.4	10	75	75.7	75.7	26.8
4(II) Land converted to wetlands	CH ₄	0.5	27.9	10	90	90.6	90.6	25.2
4(II) Peatland	CH ₄	1.3	0.7	10	90	90.6	90.6	0.6
4(II) Peat extraction remaining peat extraction	N ₂ O	0.2	0.1	10	90	90.6	90.6	0.1

The time series are complete.

6.5.13 QA/QC and verification

The peat excavation area has been verified with aerial photos and the amount of excavated peat is made by Statistics Denmark.

6.5.14 Land converted to wetland (4D2)

In order to restore nature and reduce the environmental impact, Denmark has actively re-established wetlands (Figure 6.10). The size of each restoration

project range from less than 1 ha and up to 2 500 ha. The benefit of the restoration programme is more nature but also a reduction in leaching of nitrogen into lakes, rivers and coastal water. The establishment of wetlands takes place either as large areas turned into lakes or low laying fens.

Since 1990, 27 453 have been established. These are primarily established on cropland and grassland. Of this, 6 168 hectares are converted into new lakes. A major part is restored as a part of the Danish Action Plan for the Aquatic Environment part two (VMP II, running from 1997 to 2006) where land was bought for this purpose; an additional 933 hectares of forest has been converted to wetlands. This has primarily taken place in the state owned forests. The establishment often takes place in connection to existing wetlands.

Water reservoirs for human purposes have not been established for the past 100 years, and hence are not occurring.

Methodological issues

Geographical vector layers are available for almost all established wetlands.

Change in carbon stock in living biomass

For land converted to partly covered wetland, a standard default gain value of 3 600 kg DM (dry matter) per hectare in above-ground biomass and 1 200 kg DM per hectare in below-ground biomass is used. For conversion from DM to carbon, a default fraction of 0.5 kg C per kg DM is used (IPCC 2014).

For conversion from wetland to other land use categories, the same values - recorded as a loss of carbon in the respective category (4A2, 4B2, 4C2 and 4E2) - are used.

Change in carbon stock in dead organic matter

When forest is converted to wetland, it is assumed that all dead organic matter will be cleared with instant oxidation.

Dead organic matter associated with conversion from other land use categories is assumed as not applicable.

Change in carbon stock in soils

No carbon sequestration or carbon loss is assumed for land converted to partly covered wetlands or fully water covered wetlands (lakes).

CH₄ and N₂O emissions

According to the 2013 Wetlands Supplement, the N₂O emission is negligible from restored wetlands (Chapter 3). Therefore, no N₂O emission has been estimated for land converted to wetlands.

According to the 2013 Wetlands Supplement, the CH₄ emission is 216 kg CH₄-C per ha for temperate areas, equivalent to 288 kg CH₄ per ha from restored rich wetlands (Chapter 3, Table 3.3). This has been included in the inventory.

As we currently do not have national data on area with ditches and CH₄ emission from these the default values from the 2013 Wetlands Supplement (IPCC, 2014) is followed with a ditch area of 5 %. As we use the actual reported agricultural area the area with ditches should be seen as an additional area for the total area with WE although not added in the reported hectares.

The default emission factors from the 2013 Wetlands Supplement (IPCC, 2014) is used.

The CH₄ from established wetlands is estimated as the sum of organic land (>= 12 % OC) converted from other land uses to wetlands since 1990 multiplied with the default emission factor of 288 kg CH₄ ha⁻¹. The slightly deviation in the reported IEF in CRF table 4(II) is due to roundings.

Uncertainties and time series consistency

The time series are complete. For uncertainty, see 6.5.1

QA/QC and verification

No verification has been made yet.

Recalculation

A recalculation has been made because the Danish Agricultural Agency has provided the inventory team with updated GIS polygons on established wetlands since 1995.

Planned improvements

An evaluation of actual water level on wetlands before and after conversion from cropland and grassland to wetland will be conducted in 2021 to 2024.

6.6 Settlements (4E)

The annual changes in carbon stock in settlements remaining settlements is assumed to be negligible, and because no estimates have been made, most changes are reported as NA in the CRF Table 4.E. For reporting purposes for land use conversions, a default biomass in low buildings and graveyards is established.

The total settlements area has been estimated to 486 614 hectares by the end of 1989 increasing to 539 101 hectares by the end of 2020 or to 12.5 % of the total Danish area (Table 6.26). The reported emission is hence the emission from land use changes to SE.

Table 6.26 Total area and annual emissions 1990 to 2020 from Settlement.

Settlements	1990	2000	2010	2015	2016	2017	2018	2019	2020
Settlement remaining Settlement, 1000 ha	368.8	410.1	456.1	473.1	476.5	479.9	483.2	486.6	487.6
New Settlements since 1990, 1000 ha	118.8	86.8	55.7	53.9	55.1	53.9	52.2	49.9	51.6
Settlement, total, 1000 ha	487.6	496.9	511.8	527.0	531.6	533.7	535.4	536.5	539.1
Living and dead biomass, kt C	4.5	4.6	10.1	7.8	27.6	8.1	12.0	9.0	15.1
Soil, kt C	112.3	81.4	50.5	48.3	49.5	48.1	46.6	44.6	46.1
Total, kt C	116.8	86.0	60.6	56.1	77.1	56.1	58.7	53.6	61.2
N ₂ O, kt N ₂ O	0.147	0.106	0.066	0.062	0.064	0.062	0.060	0.057	0.059
Total, kt CO ₂ eqv.	472.2	347.0	241.9	224.3	301.7	224.2	232.9	213.5	242.1

6.6.1 Settlements remaining settlements (4E1)

Settlement area

No changes in the area with settlements remaining settlements are taking place. The area is estimated from the cadastral maps and the date where the land parcel was included in the cadastral map, e.g. a change from agriculture to a permanent residence or a road.

Settlement definition

Settlements are defined as all areas with infrastructure, e.g. roads, graveyards, sport facilities etc.

6.6.2 Methodological issues

6.6.3 Change in carbon stock in living biomass

No changes in carbon stocks are reported for settlements remaining settlements.

6.6.4 Change in carbon stock in dead organic matter

No changes in carbon stocks are reported for settlements remaining settlements.

6.6.5 Change in carbon stock in soils

No changes in carbon stock in soils are assumed.

6.6.6 Uncertainties and time series consistency

Uncertainty estimates and emissions for land converted to settlements are shown in Table 6.27.

Table 6.27 Tier 1 uncertainty analysis for Settlements for 2020.

		1990	2020				Total, Uncertainty,	Uncertainty,
		Emission/ sink, Gg CO ₂ eqv.	Emission/ sink, Gg CO ₂ eqv.	Activity data, %	Emission factor, %	Combined uncertainty	uncertainty, %	95 %, Gg CO ₂ eqv.
4.E Settlements		472.2	242.1				60.6	146.6
4.E.2 Forest land converted to settlements	CO ₂	4.4	35.2	10	75	75.7	75.7	26.6
4.E.2 Other land uses converted to settlements	CO ₂	424.0	189.4	10	75	75.7	75.7	143.3
4(III) Mineralization/immobilization, Land converted to Settlements	N ₂ O	43.8	17.5	10.0	90.0	90.6	90.6	15.8

The time series are complete.

6.6.7 QA/QC and verification

Changes in SE area are based on legal registers and thus very reliable.

6.6.8 Recalculations

No recalculation has been made.

6.6.9 Planned improvements

No improvements are planned.

6.6.10 Land converted to settlement (4E2)

Land conversions to settlements is mostly taking place around the big cities and primarily on cropland and grassland.

Settlement area

The area converted to settlements is based on area statistics, cadastral maps and other digital maps to establish the LUM from 1960. For simplicity, and for the years 1990 to 2011, only three occasions are used (1990, 2005 and 2011)

with a linear increase in the area in the years between. Annual recorded changes in cadastral maps are used to estimate the annual changes from 2011 and onwards. Regarding the increase from 2012 to 2013, all new houses and roads are included in the cadastral map from 31.12.2012 to 31.12.2013. In 2020, it is estimated that 2569 hectares has been converted, mainly from cropland. There is a variation in the area conversion between years. The quite large area in 2020 is due incorporation of major road and railway constructions in the maps in this year.

Methodological issues

Change in carbon stock in living biomass

For land converted to settlement, a standard default gain value of 2200 kg DM (dry matter) per hectare in above ground biomass and 2200 kg DM per hectare in below ground biomass is used. For conversion from DM to carbon, a default fraction of 0.5 kg carbon per kg DM is used (IPCC 2014).

For conversion from settlements to other land use categories, the same value is used, but recorded as a loss of carbon in the respective category (4A2, 4B2, 4C2 and 4D2).

Change in carbon stock in dead organic matter

When forest is converted to settlements, it is assumed that all dead organic matter will be cleared. Conversion from other categories is assumed as not applicable.

The dead organic matter and the litter layer is assumed to oxidise instantly. The N content in the organic matter is converted to an N₂O emission with a default EF of 0.01 (IPCC 2014)

Change in carbon stock in soils

A default value of 96.7 tonnes carbon per ha is assumed for Settlements (Table 6.12) or 80 % of the carbon stock in mineral agricultural soils. For all areas converted from other land use to settlements, it is assumed that equilibrium state will be reached after 30 years from the carbon stock in the previous land use category. The 30 years period is chosen because of the relatively cold climate in Denmark with an average annual temperature of 8°C. The degradation rates of soil organic carbon according to C-TOOL shows that 99 % of the SOM has half-lives with > 40 years and that the IPCC 2006 GL assumes that 20 % of the SOC can be lost (IPCC 2006, Chapter 8.3.3.2).

Uncertainties and time series consistency

See uncertainties and time series consistency in Section 6.6.1.

The time series are complete.

QA/QC and verification

Changes in SE area are based on legal registers and thus very reliable.

Category-specific recalculations

No recalculations has been made.

6.7 Other Land (4F)

No permanent snow cover exists in Denmark and only a very small insignificant area with rocks and cliffs. Other land is restricted to beaches and sand dunes and estimated to 26 433 hectares.

No land use changes from 4A, 4B, 4C, 4D and 4E is reported.

6.8 Direct N₂O emissions from N fertilization of Forest Land and Other Land use

Only a very small amount of nitrogen fertilisers is used in the Danish forests and only to Christmas trees. All emissions are reported under Agriculture CRF Table 3. Ds1 since there is only one common national statistics for N fertilization in agriculture and forestry.

6.9 Emissions and removals from drainage and rewetting and other management of organic and mineral soils

CO₂ emissions are reported in Table 4A-F. N₂O emissions from CL and GL are reported under agriculture, CRF Table 3D. The N₂O emissions reported here is primarily from forest soils. CH₄ emissions from organic soils converted to other land uses are reported here. So far, no CH₄ emission from organic forest land remaining forest land has been estimated.

A large proportion of the Danish forest area may be considered as drained in the sense that the natural hydrology has been modified by establishment of ditches. Large forest areas have been drained in order to enable establishment of Norway spruce in depressions, fens and pond areas. As an example, a major state forest, Gribskov in Northern Zealand, by 1850 had an estimated wetland area 400 % larger than that of 1988 ([Gribskov](#)). During recent years, there has been an effort to restore wetland habitats in the state forests and several drained areas have been restored by filling up ditches; and in many areas of the state forests ditches are no longer maintained and will be gradually more and more ineffective over time. This is a direct consequence of the strategic plan for the state forests to convert to more Close to Nature Forest Management with a specific aim to restore natural hydrology in as many places as possible.

6.9.1 Methodological issues

Very few data exist for N₂O emissions in Danish forests. A Tier 1 emission factor of 2.8 kg N₂O-N per ha drained forest soil from the 2013 Wetland Supplement is included (IPCC 2014 - Table 2.5).

Rewetted forest soils were assumed to have an N₂O emission corresponding to the natural level and emissions were therefore by default set to zero.

CH₄ emission from organic forest soils is based on the emission factors in Table 6.12, a default area of ditches of 2.5 %, and the areas described in Section 6.9.2. No methane emissions were calculated for Inland mineral wet soils, as it has not been able to assess the area of such soils.

6.9.2 Areas of drained forest soils

Based on expert judgment, the area of drained forest soils were 65 % of mineral forest soils and 75 % of organic forest soils in 1990. It is further estimated that the amount of drained forest soils have decreased in the period until 2008 resulting in an area of drained forest soils with 55 % of mineral forest soils and 50 % of organic forest soils (see Table 6.13, Section 6.2.15 this report). Organic soils constituted 5 % of the forest area based on information on presence of peat from the NFI. The area of rewetted organic forest soils are remains

under the forest land category, since the actual changes in water level are unknown. However, we assume that the CO₂ emissions have ceased and replaced by CH₄ emissions.

6.9.3 Emissions of N₂O from drained forest soils

The total N₂O emission from forest soils has been estimated to 0.090 kt N₂O in 1990 and 0.081 kt N₂O in 2020.

6.9.4 Emissions of CH₄ from rewetted cropland and grassland soils

The default CH₄ emission factor of 39 kg CH₄ ha⁻¹ yr⁻¹ for rewetted organic cropland and grassland soils from the 2013 Wetland Supplement has been applied for organic soils having >12 % OC. For soils having 6-12 % OC, 50 % of the value is used, i.e. 19.5 kg CH₄ ha⁻¹ yr⁻¹. The area is the LPIS area included in the 2010 LPIS where the farmers not has applied for subsidies in following years. It is assumed that these areas have become so wet that they are not used for farming anymore. In 2020, the area >6 % OC has been estimated to 1864 ha.

6.9.5 Emissions of CH₄ from drained grassland soils

The default CH₄ emission factor of 16 kg CH₄ ha⁻¹ yr⁻¹ for drained organic grassland soils from the 2013 Wetland Supplement has been applied. The area is the drained grassland area with at least >12 % OC. For organic soils with 6-12 % OC is used an EF of 8 kg CH₄ ha⁻¹ yr⁻¹.

6.10 Direct nitrous oxide (N₂O) emissions from nitrogen (N) mineralization/immobilization associated with loss/gain of soil organic matter

The main land-use conversion involving deforestation is the conversion from forest to cropland and grassland and a minor deforestation to SE.

6.10.1 Methodological issues

According to IPCC (2006, Chapter 11.2.1.2, p. 11.11), a default fraction of 1 % is assumed emitted as N₂O-N during mineralization of the total N content following conversion.

For all deforested areas, it is assumed, that the forest floor disappears regardless of the land use conversion is into CL, GL, WE or SE. The average nitrogen content of forest floors based on the repeated soil inventory (13 t C ha⁻¹) with a default C:N value of 22 was used to estimate the N mineralized. A proportion of 1 % of the N stock mineralized equalling 5.13 kg N₂O-N/ha is assumed to be emitted as N₂O-N (IPCC (2006, Chapter 11.2.1.2, p. 11.11)).

N₂O emissions due to long-term changes in the carbon stock in mineral cropland soils are reported under Agriculture, CRF Table 3D.1.5. This is estimated by C-TOOL based on 20 subdivisions (counties and soil types). For each subdivision, the C:N ratio in the individual soil type is used, ranging from 10.53 to 15.89.

For estimation of the N₂O emission from CL and GL to SE, the average carbon stock in the respective land use classes, combined with a C:N value of 12 for CL and 15 for GL, is used. A proportion of 1 % of the N stock mineralized is assumed to be emitted as N₂O-N.

For land use conversion from GL and WE to CL, the default methodology from the 2006 GL is used (IPCC 2006). The used average carbon stocks are given in Table 6.12. The default methodology assumes that an N₂O emission only occur if there is a decrease in the carbon stock. The methodology will only estimate a N₂O emission if the land subject to conversion has a higher carbon stock than the land use, which it is converted to. As the carbon stock in Danish GL soil has been estimated to have lower value than cropland soils, the default methodology will only estimate a low N₂O emission for occasions where CL is converted to GL.

6.10.2 Emissions of N₂O from deforestation and land-use conversion

In 2020, the total emission of N₂O from all sources has been estimated to 0.16 kt N₂O. 51 % of this is from forestland and 37 % from land use conversion to SE. The far major part of this is an expected release of N in the soil organic matter when soil organic matter is degraded in the process where land is converted to a land use class having a lower default soil carbon stock like conversion to settlements.

6.11 Biomass burning

Burning of forest is prohibited as well as burning of wooden debris from hedgerows are very seldom. Wildfires are seldom in Denmark but some controlled burning of heathland is taking place. In 2019, there were forest fires on 27 hectares and none in 2020. Controlled burning of heathland were in 2015 around 700 hectares per year. In 2020, only 29.7 hectares were reported.

Data on wild and controlled fires has been collected by the Danish Nature Agency from the forest departments for the period 1990 to 2020. The emission factors are taken from the IPCC 2006 guidelines. As the burned forest is located on poor sandy soils, the default standing wood volume is assumed to be 150 Cubic meter per hectare, which is slightly lower than the average standing carbon stock in the Danish forests. The fraction burned for forest is taken from the guidelines whereas for heat land, a factor of 0.33 is used (based on expert judgment made by the Danish Nature Agency who is responsible for the controlled burning, Table 6.28).

Table 6.28 Burned areas 1990 –2020, ha per year.

	1990	2000	2010	2015	2016	2017	2018	2019	2020
Forest area burned, ha	150.0	0.0	0.0	0.0	0.0	0.0	0.0	27.0	0.0
Heathland area burned, ha	47.0	121.6	359.0	714.0	796.0	192.6	596.5	207.0	29.7
Total burned area, ha	197.0	121.6	359.0	714.0	796.0	192.6	596.5	234.0	29.7
Emission, CH ₄ , kt	0.0261	0.0002	0.0006	0.0012	0.0013	0.0003	0.0011	0.0058	0.0000
Emission, N ₂ O, kt	0.0014	0.0000	0.0001	0.0001	0.0001	0.0000	0.0001	0.0004	0.0000
Total, kt CO ₂ eqv.	1.0855	0.0106	0.0313	0.0622	0.0694	0.0164	0.0568	0.2515	0.0026

Uncertainty estimates are given in Table 6.29.

Table 6.29 Tier 1 uncertainty analysis for Biomass burning for 2020.

	1990	2020					
	Emission/ sink, kt CO ₂ eqv.	Emission/ sink, kt CO ₂ eqv.	Activity data, %	Emission factor, %	Combined uncertainty	Total, un- certainty, %	Uncertainty, 95 %, kt CO ₂ eqv.
4(V) Biomass Burning	1.1	0.0				22.4	0.0
4(V) Biomass Burning CH ₄	0.7	0.0	10	30	31.6	31.6	0.000
4(V) Biomass burning N ₂ O	0.4	0.0	10	30	31.6	31.6	0.000

6.12 Harvested Wood Products (HWP)

Carbon emissions from harvested wood products (HWP) have been reported since 2013. Denmark has chosen to report under Approach B, the production approach, which refers to equations 12.1, 12.3 and 12.A.6 of volume 4 of the 2006 IPCC Guidelines and the 2013 Supplementary GPG.

Carbon in the HWP pool is accounted for based on the semi-finished wood product categories: sawn wood, wood-based panels and paper, and paper products with default half-lives of 35, 25 and two years, respectively, stipulated by the 2013 Supplementary GPG. HWP originating from imported wood is excluded. HWP originating from deforestation activities (estimated directly as biomass in deforested areas able to produce HWP products – biomass from deforested areas with a canopy height above 10 m) is excluded from the calculations, as they are accounted as instantaneous oxidation.

For calculating carbon stocks in HWP, Denmark has applied the default first order decay (FOD) model stipulated by the IPCC, with the default half-lives (IPCC Tier 2 methodology). Activity data has been collected from international databases as well as from surveying the Danish wood industry. Carbon conversion factors have been derived from national forest inventory data (IPCC Tier 3 methodology).

The primary source for data on the HWP pool in Denmark is an annual questionnaire that now provides the basis for all Danish reporting to e.g. EUROSTAT and FAO, and serves as input to Statistics Denmark. Previously, there was no collection of data on the actual amounts and hence the previous reports were mainly based on data with less accuracy.

A comparison was performed for the year included in the questionnaire 2011-2013 and subsequently an extensive validation of activity data was carried out leading to corrections of historic data, especially regarding the production and export of sawnwood. The details and graphs can be found in Schou et al. (2015), where also an extensive validation of activity data, including comparison with the FAO data, was performed. The corrected data are available in the report.

According to a questionnaire on the production of the Danish wood industry, the production of sawnwood in 2020 was about 469 000 m³, while the production of wood-based panels was about 349 000 m³. The questionnaire covered an estimated >90 % of the revenue generated in the sawnwood sector and 100 % of the sector revenue for wood-based panels (there were only two relevant companies). A cross validation of the roundwood consumption showed an average deviation of 8 % for 2011-2013 between the questionnaire and the figures reported by Statistics Denmark based on harvest and trade statistics. As of 2020, the HWP pool originating from domestic harvest and domestic consumption consisted of about 6,4 million tonnes carbon (61 % from sawnwood and 39 % from wood-based panels – the paper pool was insignificant). This is equivalent to 15 % of the carbon stock in live forest biomass. The total inflow of carbon to the HWP pool in 2020 is reported to about 180 000 tonnes carbon – 88 000 tonnes from sawnwood and 92 000 tonnes from wood-based panels. The outflow from the pool is reported to about 157 000 tonnes carbon in 2019 – 88 000 tonnes from sawnwood and 69 000 tonnes carbon from wood-based panels. Thus, there has been a net carbon sequestration in HWP of about 23 000 tonnes carbon in 2019. See Table 6.30.

The estimate of the size of the total HWP stock is quite uncertain, as the empirical basis for the First Order Model (FOD) and the attached half-lives is weak. Conducting direct inventories of the carbon stock may be a method to reduce uncertainty. In the Danish case, estimates based on the FOD model for the total HWP pool, including imported wood and converted to finished wood products actually came quite close, when measured per capita, to estimates from Finland originating from a direct inventory. Regarding estimates for pool changes, uncertainty on half-life may be of less importance, as longer retention time in the pool may be traded off against higher emissions levels from the historic pool. This depends on the characteristics of the pool, i.e. the size of the pool vs. the recent inflow. Uncertainty on activity data relates to both uncertainty on measurements, e.g. caused by reporting errors, and statistical uncertainty, caused by variation in the sampled population.

Judging from the coverage and the validation results, surveying the production of semi-finished wood products in Denmark by questionnaire has been successful. It will be repeated in the following years as part of the future reporting of HWP.

Recalculation

In the review of the reporting for 2020, the calculation of annual inflow and outflow was recalculated, as there were identified a shift in formulas in the database behind the reporting. The data for harvest, production and export remain unchanged, but the flow calculations now clearly refer to the year of reporting. This has affected all wood pools for the period 1990-2020.

Table 6.30 HWP in use from domestic harvest and exported HWP (CRF table 4.Gs1).

	Gains, t C	Losses, t C	Half-life, yr	Annual Change in stock, kt C	Net emissions/ removals from HWP in use, kt CO ₂
HWP produced and consumed domestically					
Sawnwood	76	-65	35	10	-38
Wood panels	77	-52	25	24	-89
Paper and paperboard	NA	-0.01	2	-0.01	0.04
Total	152	-118		35	-127
HWP produced and exported					
Sawnwood	12.1	-11.8	35.0	0.3	-1.0
Wood panels	15.7	-18.5	25.0	-2.8	10.3
Paper and paperboard	NA	0.0	2.0	0.0	0.1
Total	27.8	-30.4		-2.5	9.3

Uncertainty estimates are given in Table 6.31.

Table 6.31 Uncertainty in HWP in use from domestic harvest.

	1990	2020					
	Emission/sink, kt CO ₂ eqv.	2020	Activity data, %	Emission factor, %	Combined uncertainty	Total, uncertainty, %	Uncertainty, 95 %, kt CO ₂ eqv.
4.G Harvested wood products	CO ₂ -2.4	-117.6	25	75	79.1	79.1	93.0

6.13 QA/QC plan

A first step of development and implementation of a general QA/QC plan for all sectors started in 2004 which is described in a publicised manual (Sørensen et al., 2005). The manual describes the concepts of quality work and how to handle quality management by using Critical Control Points and a list of Point

of Measurements (Nielsen et al., 2013). For more detailed information of the structure in the general QA/QC plan, please refer to Chapter 1.6 for QA/QC.

A complete list Points of Measures (PM) are given in Table 1.2. PM related to the agricultural inventory is listed below in Chapter 5.13.3 and are primarily connected to data storage and data processing level 1. For PM not mentioned below please refer to Chapter 1.6.

The QA/QC work specific for the LULUCF sector is still improved. The overall framework regarding a QA/QC plan for LULUCF are constructed in form of six stages and each stage focus on quality assurance and quality check in different part of the inventory process.

6.13.1 QA/QC plan expressed in Critical Control Points and Point of Measurements

Data storage level 1

Data Storage level 1	3. Completeness	DS.1.3.1	Documentation showing that all possible national data sources are included by setting down the reasoning behind the selection of datasets.
----------------------	-----------------	----------	--

The following external data are in used in the LULUCF sector.

- Data from multiple public GIS-layers to develop the annual Land Use Matrix (Building register, cadastral maps, lakes, railroads, afforestation, subsidized hedges and small biotopes, wetland restoration maps etc.
- Data from the Danish national forest inventory carried out by Department of Geosciences and Natural Resource Management, Copenhagen University
- Data from the annual agricultural census made by Statistics Denmark
- Land parcel information from the Danish Agricultural Agency including location of all agricultural fields
- Soil type maps - mineral and organic
- Input of organic matter to agricultural soils from manure is estimated in the agricultural sector.

Carbon stock changes are generally measured or modelled. The used emission factors comes primarily from IPCC Wetland supplement (IPCC 2014) and country specific measurements.

Statistics Denmark

The agricultural census made by Statistics Denmark is the main supply of basic agricultural data for crops. This include crop area and harvest yields and amount of excavated peat.

Danish Agricultural Agency

The Danish Agricultural Agency is responsible for handing all EU subsidies to the Danish farmers. All data needed for the inventory purpose is given freely to be used in the inventory. This include detailed field maps, all subsidized activities in the landscape including afforestation, areas with catch crops on farm level, location of all animals in Denmark, etc. These data are very precise.

The Danish Agricultural Agency, as the controlling authority, performs analysis of crop areas and their location. On average, 1600 to 2000 samples are analysed every year. Uncertainty in the data is seen as negligible.

National Forest Inventory

The Department of Geosciences and Natural Management (IGN), University of Copenhagen, who is responsible for the forest part of the inventory, carries out the NFI. IGN has been given unrestricted legal access to all NFI plots to monitor their current state of the forests.

Data Storage level 1	1. Accuracy	DS.1.1.1	General level of uncertainty for every dataset including the reasoning for the specific values
----------------------	-------------	----------	--

The most important emission source is related to the carbon stock in the forest, carbon stock changes in mineral agricultural soils and loss of carbon from the cultivated organic agricultural soils.

The uncertainty on the absolute C stock in the forest has been estimated to approximately 2 %. This in a very large C stock. However, because of the large stock the difference in the C stock between two consecutive measuring years can be very large, yielding a change in the emission around 80-100%. It is very difficult to reduce this uncertainty.

The same is also valid for the dynamic modelling of C stock in the mineral agricultural soils. The very large C stock of 100-120 ton C/ha may cause that small annual changes in input between years gives large changes in the estimated emissions between years. The input of agricultural debris to the model is estimate by Statistics Denmark. These data are well documented.

As the reported area with organic soils are almost constant combined with a fixed EF for the organic soils only little variation is seen between years. The largest uncertainty in relation to organic soils are the related to the country specific EF.

Regarding uncertainties for the remaining emission sources, see Chapter 6.

Data Storage level 1	1. Accuracy	DS.1.1.2	Quantification of the uncertainty level of every single data value including the reasoning for the specific values.
----------------------	-------------	----------	---

Please, refer to Chapter 6.

Data Storage level 1	1. Comparability	DS.1.2.1	Comparability of the data values with similar data from other countries, which are comparable with Denmark, and evaluation of discrepancy.
----------------------	------------------	----------	--

The estimated emission from the forest depends on growth rate (species, weather conditions) and harvest rate. It is assumed that the NFI with > 10 000 sampling plots can cover this variability. The outcome cannot directly be compared to other countries. The general view is that the Danish forests is a sink like many other European forests.

Only a few countries are modelling the carbon stock changes in mineral agricultural soils. The Danish model estimates the agricultural soils to be in steady state or a slightly increase in the carbon stock. This because of an increasing biomass input to the soils due increased yield levels and more catch crops.

The area with organic soils differs between countries and is difficult to compare. Denmark has a large share of cultivated organic soils > 12 % OC. The Danish reporting include organic soils having 6-12% OC. These soils will also have large emissions, as the organic matter in these drained soils at a certain point in the future will approach the equilibrium state for cultivated organic soils of 1-1.5 % OC. As no other countries report emissions from 6-12 % OC soils a direct comparability is difficult. The Danish CS EF for soils >12 % OC is slightly higher than the IPCC default (IPCC 2014) but similar to the German CS EF used in the German 2020 submission to UNFCCC.

Data Storage level 1	4. Consistency	DS.1.4.1	The origin of external data has to be preserved whenever possible without explicit arguments (referring to other PMs).
----------------------	----------------	----------	--

External data received are stored in the original format in the quality management database system.

Data Storage level 1	6. Robustness	DS.1.6.1	Explicit agreements between the external institution holding the data and DCE about the conditions of delivery.
----------------------	---------------	----------	---

DCE has established formal data agreements with all institutes and organisations, which deliver data, to assure that the necessary data is available to prepare the inventory on time.

Data Storage level 1	6. Robustness	DS.1.6.2	At least two employees must have a detailed insight into the gathering of every external data set.
----------------------	---------------	----------	--

Please refer to Chapter 1.7.

Data Storage level 1	7. Transparency	DS.1.7.1	Summary of each dataset including the reasoning for selecting the specific dataset.
----------------------	-----------------	----------	---

Please refer to DS 1.1.1.

Data Storage level 1	7. Transparency	DS.1.7.2	The archiving of data sets needs to be easy accessible for any person in the emission inventory.
----------------------	-----------------	----------	--

Please refer to Chapter 1.7.

Data Storage level 1	7. Transparency	DS.1.7.3	References for citation for any external data set have to be available for any single value in any dataset.
----------------------	-----------------	----------	---

A great deal of documentation already exists in the literature list, and is also achieved in the quality management database system.

Data Storage level 1	7. Transparency	DS.1.7.4	Listing of external contacts for every dataset.
----------------------	-----------------	----------	---

Statistics Denmark:

Mrs. Mona Larsen (mla@dst.dk)

Mr. Karsten K. Larsen (kkl@dst.dk)

DCA (Aarhus University):

Mr. Mogens H. Greve (greve@agro.au.dk)

Danish Agricultural Agency:

Mr. Sebastian Iuel Berg (SEBBER@lbst.dk)

Mr. Lars West Andersen (laes@lbst.dk)

The Danish Nature Agency

Mrs Marianne Damholdt Bergin (mardb@nst.dk)

Data processing level 1

Data Processing level 1	1. Accuracy	DP.1.1.1	Uncertainty assessment for every data source as input to Data Storage level 2 in relation to type of variability. (Distribution as: normal, log normal or other type of variability).
-------------------------	-------------	----------	---

The Approach 1 methodology is used to calculate the uncertainties for the agricultural sector. The uncertainties are based on a combination of IPCC guidelines and expert judgement and measured uncertainty in the National Forest Inventory) and a normal distribution is assumed.

Data Processing level 1	1. Accuracy	DP.1.1.2	Uncertainty assessment for every data source as input to Data Storage level 2 in relation to scale of variability (size of variation intervals).
-------------------------	-------------	----------	--

Please refer to DP 1.1.1.

Data Processing level 1	1. Accuracy	DP.1.1.3	Evaluation of the methodological approach using international guidelines.
-------------------------	-------------	----------	---

Data sources and calculation methodology developments are continuously discussed in cooperation with specialists and researchers in different institutes and research sections. Consequently, both the data and methods are evaluated continually according to the latest knowledge and information.

Data Processing level 1	1. Accuracy	DP.1.1.4	Verification of calculation results using guideline values
-------------------------	-------------	----------	--

The methodological approach is consistent with the IPCC 2006 Guidelines and the 2013 Wetland Supplement (IPCC 2014). See Chapter 6.

Data Processing level 1	2. Comparability	DP.1.2.1	The inventory calculation has to follow the international guidelines suggested by UN-FCCC and IPCC.
-------------------------	------------------	----------	---

The methodological approach is consistent with the IPCC 2006 Guidelines and the 2013 Wetland Supplement (IPCC 2014).

Data Processing level 1	3. Completeness	DP.1.3.1	Assessment of the most important quantitative knowledge, which is lacking.
-------------------------	-----------------	----------	--

The most important lacking information is the emission from the organic soils. Over time the organic soils becomes more wet due to lack of drainage. Hence the used EF should be reduced over time. There is no information on emissions from soils having 6-12 % OC. As times go, the organic matter disappears and the drained soils will reach a low equilibrium state. This should lead to reclassification of the area with organic soils from e.g. 6-12 % OC in the previous years and 0-6 % in the future. No information is available on this issue. There is on-going work to increase the accuracy of this emission source.

Data Processing level 1	3. Completeness	DP.1.3.2	Assessment of the most important missing accessibility to critical data sources
-------------------------	-----------------	----------	---

All known major sources are included in the inventory. In Denmark, only very few data are restricted. Accessibility is not a key issue; it is more lack of data.

Data Processing level 1	4. Consistency	DP.1.4.1	In order to keep consistency at a high level, an explicit description of the activities needs to accompany any change in the calculation procedure
-------------------------	----------------	----------	--

The calculation procedure is consistent for all years.

Data Processing level 1	4. Consistency	DP.1.4.2	Identification of parameters (e.g. activity data, constants) that are common to multiple source categories and confirmation that there is consistency in the values used for these parameters in the emission calculations
-------------------------	----------------	----------	--

Please refer to Chapter 1.7.

Data Processing level 1	5. Correctness	DP.1.5.1	Show at least once, by independent calculation, the correctness of every data manipulation.
-------------------------	----------------	----------	---

During the development of the model, all persons involved in preparation of the agricultural section have made thorough checks.

Data Processing level 1	5. Correctness	DP.1.5.2	Verification of calculation results using time series.
-------------------------	----------------	----------	--

Time series for activity data, emission factors and national emission are performed to check consistency in the methodology, to avoid errors, to identify and explain considerable year to year variations.

Data Processing level 1	5. Correctness	DP.1.5.3	Verification of calculation results using other measures.
-------------------------	----------------	----------	---

None

Data Processing level 1	5. Correctness	DP.1.5.4	Show one-to-one correctness between external data sources and the databases at Data Storage level 2
-------------------------	----------------	----------	---

In the database key ids is used to identify the unique data. The data on DS level 1 is linked to the key id used in the database so a clear reference from DS level 1 to higher levels of both DP and DS is secured.

Data Processing level 1	6. Robustness	DP.1.6.1	Any calculation must be anchored to two responsible persons that can replace each other in the technical issue of performing the calculations.
-------------------------	---------------	----------	--

Please refer to Chapter 1.7.

Data Processing level 1	7. Transparency	DP.1.7.1	The calculation principle and equations used must be described.
-------------------------	-----------------	----------	---

All calculation principles are described in the NIR.

Data Processing level 1	7. Transparency	DP.1.7.2	The theoretical reasoning for all methods must be described.
-------------------------	-----------------	----------	--

All theoretical reasoning is described in the NIR.

Data Processing level 1	7. Transparency	DP.1.7.3	Explicit listing of assumptions behind methods.
-------------------------	-----------------	----------	---

All theoretical reasoning is described in the NIR.

Data Processing level 1	7. Transparency	DP.1.7.4	Clear reference to dataset at Data Storage level 1.
-------------------------	-----------------	----------	---

Links between the different dataset are constructed.

Data Processing level 1	7. Transparency	DP.1.7.5	A manual log to collect information about recalculations.
-------------------------	-----------------	----------	---

Changes compared with the last emissions report are described in the NIR and the national emission changes is given in a table under the section, "Recalculation". The text describes whether the change is caused by changes in the dataset or changes in the methodology used. Furthermore, a log table is filled in when data are updated or adjusted continuously.

Data storage and processing level 2

For point of measurements not mentioned below, please refer to Chapter 1.7.

Data Storage level 2	5. Correctness	DS.2.5.1	Documentation of a correct connection between all data types at level 2 to data at level 1.
----------------------	----------------	----------	---

A manual checklist is under development for correct connection between all data types at level 1 and 2.

Data Processing level 2	5. Correctness	DS.2.5.2	Check if a correct data import to level 2 has been made.
-------------------------	----------------	----------	--

A manual checklist is under development for correctness of data import to level 2.

6.14 Category-specific improvements

6.14.1 Response to the review process

The table below contains the recommendations of the most recent UNFCCC review of the Danish greenhouse gas inventory, where the report is published. The Danish inventory was reviewed in 2021. The table details the status of implementation of the recommendations as well as references to where improvements have been implemented in this report.

Table 6.32 Main recommendations from the latest UNFCCC review.

CRF category/issue	Review recommendation	Review report/paragraph	MS response/status of implementation	Chapter/section in the NIR
4. General (LULUCF)	Research the impact of the land-use conversions prior to 1990 on the estimated emissions and removals from soils from 1990 onward and revise the reporting allocation and estimates, or, if Denmark considers that a disproportionate amount of effort would be required to estimate these impacts in terms of the likely level of emissions and removals (i.e. if they would be insignificant in terms of the overall level and trend in national emissions), provide justifications in the NIR for this.	L.1	We have done the best we can do in terms of creating a full land use matrix from 1960 to 2020 with all for us available data. In Annex 3E is added the	See Annex 3E.18
4. General (LULUCF)	Ensure consistent reporting of the area of organic soils between the NIR and CRF table 4 and improve QC procedures for consistent reporting of the areas of organic soils.	L.2	Improved quality control has been made. A copy and paste error was made in Table 6.22 of the NIR	See 6.4.7
4. General (LULUCF)	Ensure that any recalculations in the sector are reported with a relevant explanation and justification in line with paragraph 44 of the UNFCCC Annex I inventory reporting guidelines.	L.3	Improved quality control has been made including a thorough description of recalculations	See 6.3, 6.4, 6.5 and 6.6 in the NIR
4.A Forest land – CO ₂	Include in the NIR synthesized information on the main parameters defining the characteristics used in the calculation of biomass and growing stocks.	L.7	Improved quality control has been made including a thorough description of recalculations	See 6.2.5
4.A.1 Forest land remaining forest land – CO ₂	Provide additional information on the area and volume of clear cutting and the area subject to destructive disturbance, subject to the availability of data.	L.8	The NFI do provide consistent sample based estimates of the entire forest area. The stock change caused by cutting, including clear cuts and e.g. storm damages, are included in the available data. There is no mapping of specific areas.	See 6.2
4.A.2 Land converted to forest land – CO ₂	Improve the transparency of the NIR by explaining how land converted to forest land changed over the entire time series.	L.10	More information have been included in the NIR on the long term development, both on the land use matrix and the forest carbon pools.	See 6.1.6 for the land use matrix and see 6.2.1-6.2.4 for the development over time

4.A Forest land – CO ₂	<p>DNK CRF table 4.A shows a sharp increase in the IEF for the volume of living biomass/ha in forests between 2006 and 2007, with average IEF values of 0.22 and 1.03 t CO₂/ha for 1990–2006 and 2007–2018, respectively. Denmark provided information in the NIR (section 6.2.7, p.451) on the different data sets used to develop the growing stock values for 1990–2006 and 2007–2018, stating that consistent data were used for 2007 onward. However, the Party did not perform any recalculations to ensure consistency across the entire time series in accordance with the 2006 IPCC Guidelines (vol. 1, chap. 5). During the review, Denmark explained that the variations in the IEF for forest volume of living biomass/ha stem from the use of different methodologies for 1990–2006 and 2007–2018, and stated that it will ensure consistency across the whole time series by using consistent data in the next submission.</p> <p>The ERT recommends that Denmark ensure time-series consistency by revising the living biomass estimates to address the inconsistency caused by the use of different data sources for the periods before and after 2006.</p>	L.17	<p>The time series have been recalculated. The same methodologies have been applied to the entire time series. Dynamics of afforestation, age structure of the forest area and calculation of reporting have been reviewed.</p> <p>The recalculations include implementing robustness in the change estimates, by ensuring sufficient and independent data.</p>	See 6.2, especially 6.2.6-6.2.7
4.A.1 Forest land remaining forest land – CO ₂	<p>The inter-annual variations of net carbon stock change in deadwood/ha for 2006–2007 (824.1 per cent) and 2015–2016 (416.9 per cent) are outliers across the time series and across Parties. During the review, Denmark explained that the inter-annual variation in deadwood/ha reflects the sampling uncertainty and the continuously changing composition of the land included under the category. The Party further explained that it expects to reduce the number of outliers for future submissions by changing to a 30-year transition period for forest land remaining forest land, with a greater focus on ensuring consistency in area and carbon pools. In addition, Denmark explained that it plans to recalculate the deadwood pool for the next submission to address a recently discovered coding error, which will lead to a revision of the estimates in general.</p> <p>The ERT recommends that Denmark take steps to minimize the inter-annual variations in the net carbon stock change in deadwood/ha to the extent possible, in line with the overall uncertainty of the net removals and emissions reported, by implementing the new transition period of 30 years and by aligning the reporting frequency with the frequency of sampling to gather new data on deadwood. The ERT also recommends that the Party explain the reasons for any significant inter-annual changes in deadwood/ha in the NIR and provide a justification as to why the changes do not result in underestimation of emissions or overestimation of removals.</p>	L.18	<p>The time series have been recalculated. The same methodologies have been applied to the entire time series. Dynamics of afforestation, age structure of the forest area and calculation of reporting have been reviewed.</p> <p>The recalculations include implementing robustness in the change estimates, by ensuring sufficient and independent data.</p>	See 6.2, especially 6.2.6-6.2.7
4.A.2 Land converted to forest land – CO ₂	<p>Denmark stated in the NIR (pp.453, 457, 473, 479, 486 and 855) that it uses a 30-year transition period for land-use conversions. However, the reported areas of land-use conversion categories only include the accumulated areas of conversions since 1990 and do not cover all conversions occurring over the past 30 years. According to the 2006 IPCC Guidelines (vol. 4, chap. 3), the area under a land-use conversion category for any reporting year should be the sum of all the conversions occurring over the entire transition period chosen by the Party, as appropriate to national conditions (20 years by default). During the review, Denmark clarified that it applied the default transition period of 20 years. The Party also confirmed that the large differences in the IEF of the carbon stock change between the base year and latest reporting year are due to the fact that it did not use a 30-year transition period for years prior to the base year 1990. Consequently, the area of land converted to forest land for 1990 includes only the conversions that occurred in that year, whereas the corresponding area for 2018 includes the area of land converted to forest land accumulated over the past 28 years.</p> <p>The ERT recommends that Denmark revise the total areas of land converted to forest land reported for each year, starting with the base year, by including the areas of land converted to forest land accumulated over the past 30 years, either by extrapolating land areas before 1990 or by collecting additional historical data on land use since 1960. The ERT also recommends that Denmark provide transparent information in the NIR on the transition period applied to construct the land-use change matrix, ensuring that the information reported in the NIR reflects the actual methodological approaches applied for estimating emissions and removals as reported in the CRF tables.</p>	L.19	<p>This was resolved in the 2021 submission by implementing “a 30-year transition period for all the land-conversion categories” for all reporting years and reported it in the NIR (6.2) and reflected in the CRF. The full Land Use Matrix 1959 to 2020 is given in Annex 3E.18</p>	

4.B Cropland – CO ₂	Denmark reported in the NIR (section 6.3.7, p.469) that it overlaid soil classification maps relating to 1975 and 2010 with land-use maps to identify areas of drained organic soils. The areas of organic soils in 1975 and 2010 amounted to 243,000 and 176,124 ha, respectively. The Party used linear interpolation to estimate areas of drained organic soils for 1990–2010 and assumed a constant area of drained organic soils since 2010. However, the historical data for 1975 and 2010 used to determine the areas of drained organic soils are not representative of the more recent reporting years, and as such, using the 2010 area for 2010–2018 may result in an overestimation of emissions from drained organic lands. During the review, the Party acknowledged that the area of organic soils has changed since 2010, with greater amounts of conversion from organic soils to mineral soils occurring each year in more recent years. As such, assuming a constant area of drained organic soils since 2010 might lead to an overestimation. The ERT recommends that Denmark revise the areas of drained organic soils for 2011–2018 by collecting additional data on drainage status and recalculate the associated emissions. The ERT encourages the Party to further improve the disaggregation of AD on drained organic soils in line with the guidance on the tier 2 methodology provided in the Wetlands Supplement (chap. 2) by collecting additional data on water table (wetness) and land use at an increased level of disaggregation (e.g. by region and management practices).	L.20	Taking into account that drained organic soils over time will be depleted for organic content down to app. 1.5-2.0 % OC, all drained organic soils at a given time no longer can be seen as organic and not loose carbon. All countries reporting drained agricultural organic soils will face this. The same in Denmark with our relative thin layers of organic matter. By maintaining the area on the 2010 level is a conservative estimate. We are working on an update of the map with agricultural organic soils. It is costly and time consuming. This will probably be finished in 2024 and maybe ready for implementation in 2025/2026	See 6.3.11
4.B Cropland – CO ₂	The Party did not transparently describe the calculation of the EFs for drained organic soils in the NIR, and consequently the ERT was unable to determine whether the EFs used resulted in accurate emission estimates for organic soils with organic content of 6–12 per cent and above 12 per cent, with the former representing 60 per cent of all drained soils under cropland. Because the C-TOOL soil carbon stock simulator is unable to simulate carbon stock changes in organic soils with organic content greater than 6 per cent, Denmark used EFs based on a country-specific study (Elsgaard et al., 2012) for drained organic soils with organic content above 12 per cent and applied an adjustment of 50 per cent to calculate the EF for soils with carbon content of 6–12 per cent organic content (NIR p.471). However, the ERT noted that the country-specific study used to calculate the EF is from 2012 and is only applicable to soils with an organic content of 14–20 per cent. During the review, the Party clarified that the three soil types provided in Elsgaard et al. (2012) are fully drained organic soils, with an organic content of 15–20 per cent, which represent 40 per cent of all drained organic soils in the Land Parcel Information System. Denmark further noted that because bulk density, which best reflects the level of drainage, is higher in soils with 12 per cent organic content, assuming a 50 per cent reduction of the fixed EFs used for drained organic soils with organic content greater than 12 per cent for calculating the EFs for drained organic soils with 6–12 per cent organic content may result in a potential underestimation of emissions from these soils. However, no additional research is available to verify this assumption. The ERT recommends that the Party recalculate emissions from drained organic soils under cropland by collecting additional data on soils with 6–12 per cent organic content. The ERT also recommends that Denmark include in the NIR data and information from the study by Elsgaard et al. (2012) on calculating the EFs for drained organic soils with organic content greater than 12 per cent, including soil type, percentage of organic content and assumptions made, demonstrating their applicability for all the reporting years.	L.21	Denmark has initiated a research programme for the organic soils on the loss of organic matter from the organic soils in relation to the ground water table and total carbon stock above the ground water. We assume that the total amount of organic matter in the drained zone is more applicable for CO ₂ emission estimates compared to the % definition due to large differences in bulk density in the organic soils (0.3-1.0). A new model which take into consideration the total C stock will probably be implemented in the 2024 submission.	See 6.3.11
4.B Cropland – CO ₂	The Party reported the total area of organic soils in cropland for 2018 as 126.9 kha in DNK CRF table 4.B and as 127.4 kha in the NIR (table 6.17, p.472). During the review, Denmark explained that DNK CRF table 4.B contains an error in the area of organic soils reported, but confirmed that this does not impact the calculation of emissions. The ERT recommends that Denmark correct the total area of organic soils in cropland reported for 2018 in DNK CRF table 4.B, ensuring consistency between the areas reported in the NIR and in CRF table 4.B.	L.22	Improved QC has been implemented. The figures are now equal.	See CRF and Table 6.19 in the NIR

4.C Grassland – CO ₂	The Party reported in the NIR (section 6.4.1, p.477) that it estimated the areas of organic soils in grassland by mapping organic soils and overlaying those maps with land-use maps under grassland. In line with its approach for drained organic soils, these areas were then combined with country-specific EFs (8,400 kg C/ha/year for organic soils with at least 12 per cent organic content (Eisgaard et al., 2012) and 4,200 kg C/ha/year for those with 6–12 per cent organic content) to calculate on-site CO ₂ emissions from drained organic soils. However, the Party did not clearly indicate the extent to which the EFs used are representative of the different management practices. During the review, Denmark noted that given its use of the Land Parcel Information System, the information on management practices is already incorporated in the estimation methodology. The ERT recommends that the Party include information in the NIR on how the EFs used for drained organic soils in grassland are representative of the drained soils in terms of management practices.	L.23	More information is given in the NIR	See 6.4.1
4(II) Emissions/removals from drainage and re-wetting and other management of organic/mineral soils – CO ₂	Denmark reported in the NIR (tables 6.17, 6.20 and 6.23) and in CRF table 4(II) total CO ₂ emissions from leaching of dissolved organic carbon (off-site emissions) from drained organic soils in cropland, grassland and wetlands. However, the Party did not explain the methodological approach or the EFs used to calculate emissions. During the review, the Party explained that it used default EFs from the Wetlands Supplement in the absence of country-specific EFs. The ERT recommends that Denmark include in the NIR information on the methodological approach and the EFs used for calculating off-site emissions from leaching of dissolved organic carbon in cropland, grassland and wetlands.	L.24	More information is given in the NIR	See. 6.5.1
4(II) Emissions/removals from drainage and re-wetting and other management of organic/mineral soils – CH ₄	Denmark calculated CH ₄ emissions from drained organic soils and ditches using the default EFs from the Wetlands Supplement (chap. 2, table 2.3 and equation 2.6). As mentioned in the NIR (table 6.18, p.477), the uncertainty associated with the use of the EF is 90 per cent. Given that CH ₄ emissions from drained organic soils is a key category (as reported in CRF table 7), according to the UNFCCC Annex I inventory reporting guidelines (para. 11) and in line with the IPCC good practice guidance, the Party should use a higher-tier method (e.g. a tier 2 method using country-specific EFs) to calculate emissions for the category. During the review, the Party explained that it will improve the stratification of drained organic soils for future submissions and, to this end, measurements of soil wetness are being collected using remote sensing, and carbon stock and wetness are being monitored using drone-based remote sensing. The studies aim to improve Denmark's groundwater map for low-lying areas on a 10 m × 10 m grid using machine learning. More than 10,000 groundwater sampling measurements taken in organic soils in 2009 are due to be revisited in 2020 and 2021, thus enabling Denmark to move to a tier 3 method with a dynamic degradation model of organic content in the drained zones. The ERT encourages Denmark to use higher-tier methods (e.g. by developing and using country-specific EFs) to calculate CH ₄ emissions from drained organic soils and drained ditches for cropland, grassland and wetlands in accordance with the IPCC good practice guidance. The ERT notes that, in order to develop country-specific EFs, the Party could consider stratifying drained organic soils by nutrient status and drainage class on the basis of country-specific studies in accordance with the guidance provided in the Wetlands Supplement.	L.25	See L.41. Provincial findings (unpublished) in our research program has shown that national measured data on CO ₂ and CH ₄ emission from cropland, grassland and wetlands follow the model used in the German inventory (Thiemeier et al. 2020) very closely with small or no deviation. With the planned research programme we think we can get updated emissions where the emission factors are included on a much larger dataset and which are in line with the much larger German dataset (>140 measurements).	6.3 and 6.4

6.15 References

AIS, 2002: Nielsen, K., Stjernholm, M., Olsen, B.Ø., Müller-Wohlfeil D.-I., Madsen I.-L., Kjeldgaard, A., Groom, G., Hansen, H.S., Rolev, A.M., Hermansen, B., Skov-Petersen, H., Johannsen, V.K., Hvidberg, M., Jensen, J.E., Bacher, V. & Larsen, H., 2000: AIS, 2002: The Area Information System - AIS. Ministry of Environment and Energy, Denmark.

Arealinformation, 2011a: The national registration of protected habitat types. Copenhagen: Arealinformation. Available at:

<http://arealinformation.miljoportal.dk/distribution/>

Arealinformation, 2011b: Registration of habitat types within Natura2000 designations (DEVANO). Copenhagen: Arealinformation. Available at: <http://arealinformation.miljoeportal.dk/distribution/> (April 2014).

Axe, M.S., Grange, I.D. & Conway, J.S., 2017: Carbon storage in hedge biomass—A case study of actively managed hedges in England, *Agriculture, Ecosystems and Environment* 250 (2017) 81–88.

Callesen, I., Liski, J., Raulund-Rasmussen, K., Olsson, M., Tau-Strand, L. & Westman, C.J. 2007: Nitrogen pools and C:N ratios in Nordic well-drained forest soils related to climate and soil texture. *Boreal environment research* 12, 681-692.

Callesen, I., Stupak, I., Georgiadis, P., Johannsen, V.K., Østergaard, H.S. & Vesterdal, L. 2015: Soil carbon stock change in the forests of Denmark between 1990 and 2008. *Geoderma Regional* 5, 169-180.

Christiansen, J.R., Gundersen, P., Frederiksen, P. & Vesterdal, L. 2012a: Influence of hydromorphic soil conditions on greenhouse gas emissions and soil carbon stocks in a Danish temperate forest. *Forest Ecology and Management* 284, 185-195.

Christiansen, J.R., Vesterdal, L. & Gundersen, P. 2012b: Nitrous oxide and methane exchange in two small temperate forest catchments-effects of hydrological gradients and implications for global warming potentials of forest soils. *Biogeochemistry* 107, 437-454.

Danish Defence, 2011: Management plans for defence holdings. Copenhagen: Danish Defence.

Danish Geodata Agency, 2011: National topographic database (Kort10) 2011. Copenhagen: Danish Geodata Agency. Danish Geodata Agency, 2012a: National cadastre map 2012. Copenhagen: Danish Geodata Agency.

Danish Geodata Agency, 2012: National topographic database (Kort10) 2012. Copenhagen: Danish Geodata Agency. Danish Nature Agency, 2011: Management plans for state forests. Copenhagen: Danish Nature Agency.

Danish Nature Agency, 2011: Management plans for state forests. Copenhagen: Danish Nature Agency.

DST, 2021: Statistics Denmark. Available at: Statistikbanken.dk

Elsgaard L, Görres, C.M., Hoffman, C.C., Blicher-Mathiesen, G., Schelde K. & Petersen S.O. 2012: Net ecosystem exchange of CO₂ and carbon balance for eight temperate organic soils under agricultural management. *Agriculture Ecosystems and Environment* 162:52-67.

Eriksen, J., Nordemann Jensen, P. & Jacobsen, B.H. (eds) 2014: Virkemidler til realisering af 2. generations vandplaner og målrettet arealregulering. DCA report No. 52, 330 pp. Aarhus University.

FAO, 2010: Global Forest Resources 2010. Food and Agriculture Organization of the United Nations, Rome.

Greve, M.H., Christensen, O.F., Greve, M.B. & Kheir, R.B. 2014: Change in Peat Coverage in Danish Cultivated Soils During the Past 35 Years, *Soil Science*, May 2014 - Volume 179 - Issue 5 - p 250–257.

Grønlund, A., Hauge, A., Hovde, A. & Rasse, D.P. 2008: Carbon loss estimates from cultivated peat soils in Norway: a comparison of three methods, *Nutr. Cy. Agroecos.*, 81, 157–167.

IRR, 2007: Report of the review of the initial report of Denmark. Available at: https://unfccc.int/files/kyoto_protocol/compliance/plenary/application/pdf/cc-ert-irr-2007-13_report_of_review_of_ir_of_denmark.pdf

IPCC 2006: 2006 IPCC Guidelines for National Greenhouse Gas Inventories, Prepared by the National Greenhouse Gas Inventories Programme, Eggleston H.S., Buendia L., Miwa K., Ngara T. & Tanabe K. (eds). Published: IGES, Japan.

IPCC, 2014: Wetland supplement. Supplement to the 2006 IPCC Guidelines for National Greenhouse Gas Inventories: Wetlands, Hiraishi, T., Krug, T., Tanabe, K., Srivastava, N., Baasansuren, J., Fukuda, M. & Troxler, T.G. (eds). Published: IPCC, Switzerland.

Johannsen, V.K., Nord-Larsen, T., Vesterdal, L., Suadicani, K. & Callesen, I. 2017: Identifying potential uncertainties associated with forecasting and monitoring carbon sequestration in forests and harvested wood products. København: Department of Geosciences and Natural Resource Management, University of Copenhagen, 2017. 82 p. (IGN Report).

Johannsen, V.K., Levin, G., Caspersen, O.H., Nord-Larsen, T. & Sørensen, I.H. 2018: Validation of land use/land cover changes for Denmark. Department of Geosciences and Natural Resource Management, University of Copenhagen, Frederiksberg. 23 p. ill. Available at: https://static-curis.ku.dk/portal/files/209289237/Validation_of_land_use_land_cover_changes_for_Denmark_report_2018.pdf

Johannsen, V.K. & Stupak, I. 2021: Carbon pools of Danish Forest Census 1881-2000. København. Department of Geosciences and Natural Resource Management, University of Copenhagen, (IGN Note – in prep).

KORTFORSYNINGEN. 2020. GeoDanmark Ortofoto [Online]. Copenhagen: Styrelsen for Dataforsyning og Effektivisering. Available at: [GeoDanmark Ortofoto \(blokinddelt\) | Kortforsyningen download](#) [Accessed 2020].

Knudsen, M.A., Nord-Larsen, T., Riis-Nielsen, T., Cordius-Hansen, J.G., Nielsen, A.O. & Kudahl, T. 2017: Skovstatistisk feltinstruks 2016. Frederiksberg: Institut for Geovidenskab og Naturforvaltning, Københavns Universitet, 2017. 198 p. (IGN Rapport).

Larsen, L. 2014: Pindstrup Mosebrug, (personal comm.).

Larsen, P.H. & Johannsen, V.K. (eds.) 2002: Skove og plantager 2000. Danmarks Statistik, Skov and Landskab og Skov- og Naturstyrelsen. 171 p. ISBN: 87-501-1287-2.

LBST, 2021: Confidential data on farm level received from the Danish Agricultural Agency. Available at: www.lbst.dk

Levin, G., Blemmer, M., Gyldenkærne, S., Johannsen, V.K., Caspersen, O.H., Petersen, H.S., Nyed, P.K., Becker, T., Bruun, H.G., Fuglsang, M., Münier, B., Bastrup-Birk, A. & NordLarsen, T. 2014: Estimating land use/land cover changes in Denmark from 1990 - 2012. Technical documentation for the assessment of land use/land cover changes for estimation of carbon dioxide fixation in soil. Aarhus University, DCE - Danish Centre for Environment and Energy, 34 pp. Technical Report from DCE - Danish Centre for Environment and Energy No. 38 Available at: <http://www.dce.au.dk/pub/TR38.pdf>

Levin, G., Angelidis, I. & Gyldenkærne, S. 2020: Assessment of change in biomass from 2006 to 2014/2015 of non-forest woody vegetation in Denmark. Technical documentation. Aarhus University, DCE - Danish Centre for Environment and Energy, 30 pp. Technical Report No. 178. Available at: <https://dce2.au.dk/pub/TR178.pdf>

Lingner, S., Thiessen, E., Müller, K. & Hartung, E. 2018: Dry Biomass Estimation of Hedge Banks: Allometric Equation vs. Structure from Motion via Unmanned Aerial Vehicle, *JOURNAL OF FOREST SCIENCE*, 64, 2018 (4): 149-156.

Lohila, A., Aurela, M., Tuovinen, J.-P. & Laurila, T. 2004: Annual CO₂ exchange of a peat field growing spring barley or perennial forage, *J. Geophys. Res.*, 109, D18116, doi:10.1029/2004JD004715

Madsen, S.F. 1985: Overensstemmende stammeside- og vedmassefunktioner for fem forskellige nåletræarter (Compatible Tree Taper and Volume Functions for five Different Conifers). *Beretninger fra det Forstlige Forsøgsvæsen*, 338, 95-140.

Madsen, S.F. 1987: Vedmassefunktioner for nogle vigtige danske skovtræarter. *Det Forstlige Forsøgsvæsen* 40, 47-242.

Madsen, S.F. & Heusèrr, M. 1993: Volume and stem taper functions for Norway spruce. *Forest and Landscape Research* 1, 51-78.

Maljanen, M., Martikainen, P.J., Walden, J. & Silvola, J. 2001: CO₂ exchange in an organic field growing barley or grass in eastern Finland, *Global Change Biol.*, 7, 679-692.

Maljanen, M., Komulainen, V.-M., Hytönen, J., Martikainen, P.J. & Laine, J. 2004: Carbon dioxide, nitrous oxide and methane dynamics in boreal organic agricultural soils with different soil management, *Soil Biol. Biochem.*, 36, 1801-1808.

Maljanen, M., Sigurdsson, B.D., Guðmundsson, J., Óskarsson, H., Huttunen, J.T. & Martikainen, P.J. 2010: Greenhouse gas balances of managed peatlands in the Nordic countries - present knowledge and gaps. *Biogeosciences* 7, 2711-2738.

Ministry of Environment and Food of Denmark, 2021: Supplier of field block maps, field maps, subsidized afforestation data, wetland restoration areas, supported new hedges and biotopes, etc.

- Ministry of Housing, Urban and Rural Affairs, 2012: Danish building register (BBR). Copenhagen: Ministry of Housing, Urban and Rural Affairs.
- Moltesen, P. 1985: Skovtræernes ved og anvendelse. Skovteknisk Institut, Frederiksberg. 132 p.
- Nielsen, O.-K., Plejdrup, M.S., Winther, M., Gyldenkerne, S., Thomsen, M., Fauser, P., Nielsen, M. Mikkelsen, M.H., Albrektsen, R., Hjelgaard, K., Hoffmann, L. & Bruun, H.G. 2013. Quality manual for the Danish greenhouse gas inventory. Version 2. Aarhus University, DCE – Danish Centre for Environment and Energy, 44 pp. Scientific Report from DCE – Danish Centre for Environment and Energy No. 47. Available at: www.dce.au.dk
- Nord-Larsen, T. & Johannsen V.K., 2016: Danish National Forest Inventory. Design and calculations. NFI working paper 2016. Available at: www.ku.dk
- Nord-Larsen, T., Johannsen, V., Riis-Nielsen, T., Thomsen, I. & Jørgensen, B. 2021. Skovstatistik 2019: Forest statistics 2019. Frederiksberg: Department of Geosciences and Natural Resource Management, University of Copenhagen. Available at: https://static-curis.ku.dk/portal/files/253402451/Rapport_Skovstatistik_2019.pdf
- Nord-Larsen, T., Johannsen, V.K., Riis-Nielsen, T., Thomsen, I.M. & Jørgensen, B.B. 2019: Skovstatistik 2018: Forest statistics 2018. Frederiksberg: Institut for Geovidenskab og Naturforvaltning, Københavns Universitet.
- Nord-Larsen, T., Meilby, H. and Skovsgaard, J.P. 2017: Simultaneous estimation of biomass models for 13 tree species: effects of compatible additivity requirements.
- Nord-Larsen, T. & Nielsen, A. 2015. Biomass, stem basic density and expansion factor functions for five exotic conifers grown in Denmark. Scandinavian Journal of Forest Research, 30.
- Nord-Larsen, T., Riis-Nielsen, T. & Ottosen, M. 2017b. Forest resource map of Denmark: Mapping of Danish forest resource using ALS from 2014-2015. IGN Report. Frederiksberg: Department of Geosciences and Natural Resource Management, University of Copenhagen.
- Schou, E., Suadicani, K. & Johannsen, V.K. 2015: Carbon Sequestration in Harvested Wood Products (HWP): Data for 2013-Reporting to the UNFCCC, Final Draft. Institut for Geovidenskab og Naturforvaltning, Københavns Universitet. IGN Rapport. Available at: www.ku.dk
- Skovsgaard, J.P., Bald, C. & Nord-Larsen, T. 2011: Functions for biomass and basic density of stem, crown and root system of Norway spruce (*Picea abies* (L.) Karst.) in Denmark, Scandinavian Journal of Forest Research, vol. 26 (Suppl 11), pp. 3-20.
- Skovsgaard, J.P. & Nord-Larsen, T. 2012: Biomass, basic density and biomass expansion factor functions for European beech (*Fagus sylvatica* L.) in Denmark. European Journal of Forest Research 131(4):1035-1053. DOI: 10.1007/s10342-011-0575-4

Sørensen, P.B., Illerup, J.B., Nielsen, M., Lyck, E., Bruun, H.G., Winther, M., Mikkelsen, M.H. & Gyldenkerne, S. 2005: Quality manual for the green-house gas inventory. Version 1. National Environmental Research Institute. Research Notes from NERI 224: 25 pp. (electronic). Available at: http://www2.dmu.dk/1_viden/2_Publikationer/3_arbrapporter/rapporter/AR224.pdf

Taghizadeh-Toosi, A., 2015: C-TOOL A simple tool for simulation of soil carbon turnover Technical report October 2015. Available at:

Taghizadeh-Toosi, A., Olesen, J.E., Kristensen, K., Elsgaard, L., Østergaard, H.S., Lægdsmand, M., Greve, M.H. & Christensen, B.T. 2014a: Changes in carbon stocks of Danish agricultural mineral soils between 1986 and 2009. *European Journal of Soil Science*, vol. 65, no. 5, pp. 730-740.

Taghizadeh-Toosi, A., Christensen, B.T., Hutchings, N.J., Vejlin, J., Kätterer, T., Glendinin, M. & Olesen, J.E. 2014b: C-TOOL: A simple model for simulating whole-profile carbon storage in temperate agricultural soils, *Ecological Modelling* 292, 11-25.

Vejre, H., Callesen, I., Vesterdal, L. & Raulund-Rasmussen, K. 2003: Carbon and Nitrogen in Danish forest soils - Contents and distribution determined by soil order. *Soil Science Society of America Journal* 67: 335-343.

Vesterdal, L. & Raulund-Rasmussen, K. 1998: Forest floor chemistry under seven tree species along a soil fertility gradient. *Can.J.For.Res.* 28:1636-1647. Available at: <https://cdsciencepub.com/doi/abs/10.1139/x98-140>

Vesterdal, L., Jørgensen, F.V., Callesen, I. & Raulund-Rasmussen, K. 2002a: Skovjordens kulstoflager - sammenligning med agerjorde og indflydelse af intensiveret biomasseudnyttelse. In: Christensen, B.T. (ed.), *Biomasse til energiformål - konsekvenser for jordens kulstofbalance i land- og skovbrug*. DJF rapport Markbrug nr. 72.

Vesterdal, L., Ritter, E. & Gundersen, P. 2002b: Change in soil organic carbon following afforestation of former arable land. *Forest Ecology and Management* 169: 141-151.

Vesterdal L., Rosenqvist, L., van der Salm, C., Hansen, K., Groenenberg B.-J. & Johansson, M.-B. 2007: Carbon sequestration in soil and biomass following afforestation: experiences from oak and Norway spruce chronosequences in Denmark, Sweden and the Netherlands. In: Heil G., B. Muys and K. Hansen. *Environmental Effects of Afforestation in Northwestern Europe - From Field Observations to Decision Support*. Springer, *Plant and Vegetation* 1: 19-52.

7 Waste

7.1 Overview of the sector

The waste sector consists of the CRF source categories: 5.A. *Solid Waste Disposal*, 5.B. *Biological treatment of solid waste*, 5.C. *Incineration and open burning of waste*, 5.D. *Wastewater treatment and discharge* and 5.E. *Other*. The data presented in Chapter 7 relate to Denmark only, whereas information for Greenland is included in Chapter 16 and for the Faroe Islands in Annex 8.

Emissions from sludge spreading on fields, are included in agriculture, see Chapter 5.

In Table 7.1.1, an overview of all emissions from the waste sector is presented. The emissions are taken from the CRF tables and are presented as rounded figures. The full time series is presented in Annex 3F, Table 3F-1.1.

Table 7.1.1 Emissions for the waste sector, kt CO₂ equivalents.

		1990	1995	2000	2005	2010	2015	2016	2017	2018	2019	2020
5.A. Solid waste disposal	CH ₄	1536	1331	1073	909	772	653	620	593	576	534	537
5.B. Biological treatment of solid waste	CH ₄	32	52	92	116	141	184	242	275	295	331	374
5.B. Biological treatment of solid waste	N ₂ O	22	30	57	56	64	65	65	71	71	73	73
5.C. Incineration and open burning of waste	CH ₄	0.01	0.01	0.01	0.02	0.02	0.02	0.02	0.02	0.02	0.02	0.02
5.C. Incineration and open burning of waste	N ₂ O	0.19	0.21	0.21	0.23	0.28	0.26	0.27	0.27	0.28	0.28	0.27
5.D. Waste water treatment and discharge	CH ₄	41	43	46	47	48	49	50	50	51	52	53
5.D. Waste water treatment and discharge	N ₂ O	239	245	174	166	141	153	147	150	151	144	147
5.E. Other	CO ₂	22	24	22	22	23	22	24	24	24	23	23
5.E. Other	CH ₄	3	3	3	3	3	3	3	3	3	3	3
5. Waste	total	1896	1729	1467	1319	1191	1130	1152	1166	1173	1160	1210

5.A. *Solid Waste Disposal* is the dominant source in the waste sector with contributions in the time series varying from 81 % (1990) to 44 % (2020) of the total emission given in CO₂ equivalents. The emissions are decreasing throughout the time series, due to a reduction in the amounts of organic waste deposited at landfills. Comparing 2020 with 1990, the emissions from Solid Waste Disposal Sites have decreased with 65.1 %.

5.B. *Biological treatment of solid waste*. This source contributes with CH₄ emissions from 5.B.1 composting and 5.B.2 industrial and manure-based biogas production and N₂O emissions from 5.B.1 composting. The contribution from 5.B to the total emission from the waste sector provided in units CO₂ equivalent ranges from 2.9 % in 1990 to 37.0 % in 2020; CH₄ contributes the most to the sectorial total, varying between contributions of 1.7 % (1990) and 30.9 % (2020). Comparing 2020 with 1990, the sum of CH₄ and N₂O emissions (in units CO₂ equivalent) from composting and manure-based biogas plants in total have increased with a factor 7.2.

The increase in the GHG emission trend from category 5.B is most significant for sub-sector 5.B.2, Anaerobic digestion at biogas facilities, the level of methane emissions in 2020 being a factor 50.7 higher than in the methane emission level in 1990. The methane emission from biogas production increases

from 5.6 kt in 1990 to 289 kt CO₂ equivalents in 2020, while the GHG emission from composting increased from 49 kt in 1990 to 158 kt CO₂ equivalents in 2020.

5.C. Incineration and open burning of waste. This source contributes with CH₄ and N₂O emissions from human and animal cremations. The contribution to the sectorial total ranges between 0.01 % and 0.03 % throughout the time series. The trend for the total emissions 1990 - 2020 from this source have increased with 43.7 %.

5.D. Waste water treatment and discharge. This source contributes with CH₄ and N₂O emissions. The contribution to CO₂ equivalent emissions from the sum of CH₄ and N₂O is 14.8 % in 1990 and 16.5 % in 2020.

CH₄ contributes with 2.2 % and 4.4 % to the sectorial total in 1990 and 2020. The CH₄ emissions increases steadily over the time series from 41 kt CO₂ equivalents in 1990 to 53 kt CO₂ equivalents in 2020. N₂O contributes with 12.6 % and 12.1 % to the sectorial total in 1990 and 2020 with a decreasing trend from 239 kt CO₂ equivalents in 1990 to 147 kt CO₂ equivalents in 2020. The N₂O emission in 2020 compared to 1990 shows a decrease of 38.6 %, while for CH₄ a steady increase from 1990 to 2020 of 28.7 % is observed.

The trend for the total CO₂ equivalent emissions from sector 5.D Wastewater treatment and discharge has decreased from 280 kt CO₂ equivalents in 1990 to 200 kt CO₂ equivalents in 2020. Compared to 1990, the GHG emissions in 2019 have decreased with 28.7 %.

5.E. Other. This source contributes with CO₂ and CH₄ emissions from accidental fires. No emission factors for N₂O are available. The contribution to the total emissions from the waste sector varies between 1.3 % and 2.3 %. Compared to 1990, the GHG emissions in 2020 have increased with 5.2 %.

As a result for the entire waste sector, the emission in units of CO₂ equivalents (provided in Table 7.1.1) is decreasing throughout the time series; the emission in 2020 has decreased with 36.2 % compared to 1990.

The Waste Sectors contribution to the national total excluding LULUCF are between 1.6 % (1996) and 2.6 % in 2020.

Table 7.1.2 Reported emissions, calculated methods and type of emissions factors for the subcategory waste handling in the Danish inventory, (CS=country specific, D=default).

CRF Source	Emissions reported	Method	Emission factor
5.A Solid Waste Disposal	CH ₄	Tier 2, CS	CS, D
5.B Biological treatment of solid waste			
5.B.1 Composting	CH ₄	Tier 1, Tier 2	D, CS
5.B.1 Composting	N ₂ O	Tier 1, Tier 2	D, CS
5.B.2 Anaerobic digestion at biogas facilities	CH ₄	Tier 2	CS
5.C Incineration and open burning of waste			
5.C.1 Incineration of corpses	CH ₄	Tier 1	D, CS
5.C.1 Incineration of corpses	N ₂ O	Tier 1	D, CS
5.C.2 Incineration of carcasses	CH ₄	Tier 1	D, CS
5.C.2 Incineration of carcasses	N ₂ O	Tier 1	D, CS
5.D Wastewater treatment and discharge			
5.D.1 Domestic wastewater	N ₂ O	CS	CS
5.D.1 Domestic wastewater	CH ₄	CS	CS
5.D.2 Industrial wastewater	N ₂ O	CS	CS
5.E Other			
5.E.1 Accidental fires	CO ₂	Tier 1, CS	CS, OTH
5.E.1 Accidental fires	CH ₄	Tier 1, CS	CS, OTH

7.1.1 Key category identification

In the key category analysis (KCA) the waste emissions are divided into thirteen categories. In the Approach 1 KCA, three of the thirteen categories are identified as a key category. At Approach 2 KCA, five of the thirteen source categories are identified as key categories in 2020 (Table 7.1.3). The Approach 1 key category analysis is based on ranking of absolute quantitative emissions/removals, while the Approach 2 KCA takes into account the uncertainties in the calculated emissions (cf. Chapter 1.5).

Of the thirteen source categories shown in Table 7.1.3, four categories, i.e. *5.A Solid Waste Disposal*, *5.B.1 Composting* and *5.B.2 Anaerobic digestion at biogas facilities* and *5.D.1 Domestic wastewater* are identified as key sources for level.

Key source categories for level

According to the level analysis, for both Approach 1 and 2 KCA, *5.A. Solid Waste Disposal* is a key category for level in 1990 and 2020.

Category *5.B.1 Composting* is a key category for CH₄ emissions in 2020 according to the level assessment for Approach 2 KCA only. Category *5.B.2 Anaerobic digestion at biogas facilities* is identified as key category for level in 2020 according to the Approach 1 KCA.

Category *5.D.1 Domestic wastewater* is a key category for N₂O emissions in 2020 according to the level analysis, for both Approach 1 and 2 KCA.

Key source categories for trend

Both category *5.A. Solid Waste Disposal* and *5.B.2 Anaerobic digestion at biogas facilities* are CH₄ key categories for trend from 1990 to 2020 according to both Approach 1 and 2. Category *5.B.1 Composting* is identified as a key category for CH₄ and N₂O emission trend according to the Approach 2 KCA only.

Category 5.D.1 *Domestic wastewater* is a key category for the N₂O emission trend according to the Approach 2 KCA only.

Identified key source categories within the waste sector are presented in Table 7.1.3. For further information on the KCA level and trend assessments please refer to Chapter 1.5 and Annex 1.

Table 7.1.3 Key category identification Approach 1 and Approach 2 from the waste sector 1990 and 2020

		Approach 1			Approach 2		
		1990	2020	1990-2020	1990	2020	1990-2020
5.A Solid waste disposal	CH ₄	Level	Level	Trend	Level	Level	Trend
5.B.1. Composting	CH ₄	-	-	-	-	Level	Trend
5.B.1. Composting	N ₂ O	-	-	-	-	-	Trend
5.B.2. Anaerobic digestion at biogas facilities	CH ₄	-	Level	Trend	-	-	Trend
5.C.1 Incineration of corpses	CH ₄	-	-	-	-	-	-
5.C.1 Incineration of corpses	N ₂ O	-	-	-	-	-	-
5.C.2 Incineration of carcasses	CH ₄	-	-	-	-	-	-
5.C.2 Incineration of carcasses	N ₂ O	-	-	-	-	-	-
5.D.1 Domestic wastewater	CH ₄						
5.D.1 Domestic wastewater	N ₂ O	-	Level	-	-	Level	Trend
5.D.2 Industrial wastewater	N ₂ O	-	-	-	-	-	-
5.E Accidental fires**	CO ₂						
5.E Accidental fires**	CH ₄	-	-	-	-	-	-

*Direct and indirect emissions.

** Vehicles and Buildings.

7.2 Solid waste disposal

In the first half of the 20th century the landfills were relatively primitive, but up through the 20th century the landfills have become more and more regulated and streamlined. According to the Danish EPA, there are approx. 2500 old uncontrolled landfills (DEPA, 2013d), typically constructed before 1973 (DEPA, 2001d). With the adoption of the Environmental Protection Act in 1973 (DEPA, 2000), and implementation of the first regulation on environmental approval of landfills requirements to location, design and operation in a controlled manner was put forward by Danish Environmental Protection Agency (DEPA, 1974). Since 1974, only managed waste disposal sites with bottom membranes and/or leachate collection systems have been constructed in Denmark (DEPA, 2001d).

A newly published survey of the opportunities and challenges in landfill mining in Denmark performed by the knowledge centre for mineral resources reports a total of 4,000 waste disposal sites in Denmark corresponding to an area of 143 km² or 0.3 % of Denmark's land area (GEUS, 2020a, b).

In 1999, the European Landfill Directive was adopted (Landfill Directive 1999) providing Member States a timeframe of 10 years to implement the rules, implemented in Denmark in 2001 in the form of the Executive Order on landfills (Executive Order 650, 2001). Besides setting up requirements for how the waste may be disposed of, the Deposit Order also contain requirements for providing security, which must ensure that sufficient funds are saved to cover the costs of decommissioning and post-treatment of the landfill (DEPA, 2002). As a consequence of the stricter rules for interior design, many landfills were closed by the end of the year 2000 and in period until 2009 where 200 sites were closed. The closing of landfill sites in Denmark

peaked in 1980 and the majority of the landfills in Denmark closed before the year 2000 (GEUS, 2020a, b).

In 2002, there were a total of 53 active landfills in Denmark (DEPA, 2003c) and today 49 active landfills exist of which 43 have reported receiving waste. The amount of deposited organic waste has decreased markedly throughout the time series and is reported under the CRF source category 5.A.1 *Managed waste disposal sites*, as all landfills in Denmark are managed assuming that all closed landfills have been through post-treatment and are covered by a 1 m top soil layer before 1990.

The general development in the amount of solid waste disposed of at landfills is influenced by government instruments such as the "Action plan for Waste and Recycling 1993-1997" and "Waste 21 1998-2004" (The Danish Government, 1999). The latter plan had, inter alia, the goal to recycle 64 %, incinerate 24 % and deposit 12 % of all waste. The goal for deposited waste was met in 2000. Further, in 1996 a municipal obligation to assign combustible waste to incineration was introduced. In 2003, the Danish Government set up targets for the year 2008 for waste handling in a "Waste Strategy 2005-2008" report (The Danish Government, 2003). According to this strategy, the target for 2008 is a maximum of 9 % of the total waste to be deposited at landfills. In the waste statistics report for the year 2004, data shows that this target was met, since 7.7 % of total waste was deposited in 2004 (DEPA, 2006a). Waste Strategy 2009-12, part I (The Danish Government, 2009) was the sixth waste management plan or strategy adopted by the successive governments dating back to 1986. Waste Strategy 2009-12 set up targets for 2012 according to which a maximum of 6 % of the total waste produced is to be deposited (The Danish Government, 2009). In 2009, it appears that this target has already been met as only 6 % of all produced waste was deposited at landfills. Data on final disposal of waste in Denmark is presented in Annex 3F, Table 3F-2.1, showing that the percentage of waste deposited at landfills equals a constant level of approximately 4 % of the total waste produced in the country since 2013.

Waste Strategy 2009-2012, Part II included goals of continued decrease in the amount of waste being deposited in Denmark and an increase in reuse, recycling and recovery (The Danish Government, 2010). This report includes an evaluation of the capacity of Danish solid waste disposal sites divided into waste classes: inert, mineral, mixed and hazardous waste. The same waste classes are defined in the new Statutory Order for Landfill (Statutory Order no. 719, 24/06/2011), which refers to the Statutory Order for Waste (Statutory Order no. 1309, 18/12/2012) regarding characterisation of the waste according to the European waste code system; the EWC-code list included in Annex 2 of the statutory Order no. 1319. The New Danish Waste Reporting System (www.ads.mst.dk) is based on the EWC-code system, which forms the basis for the estimation of yearly deposited 18 waste types as further described in this chapter and in Annex 3F. The Danish EPA have collected waste statistics according to the new Waste Data System since 2010. The design of the Waste Data System is considerably different from the ISAG Waste Information System it succeeds. The new waste reporting system (2010-2020) provides statistics of waste amounts according to the waste producer and the amount of waste according to treatment type, e.g. landfill. Both statistics refers to the receiver, i.e. receivers of produced waste (waste collection companies, and receivers of waste for treatment, e.g. landfill operators. Statistics on treatment types are assumed to be final treatment;

i.e. meaning that none of the waste is temporary landfilled (Nissen, 2017a). The Danish EPA are conducting quality assurance of the reported data in the new data reporting system continuously supported by in house plant level recalculations of activity data at plant level.

7.2.1 Source category description

From 1994 to 2005, the number of registered active solid waste disposal sites (SWDSs) landfill sites in Denmark has decreased from 176 to 134 (DEPA, 2006b, 2013a). There were 56 active disposal sites (SWDS) in 2015 (Nissen, 2017a, b). In 2020, 49 active disposal sites reporting to the new waste data system. Methane collections from 29 of these SWDS are reported to be used at energy-producing installations in the Energy statistics in 2021 (DEA, 2020a). Furthermore, the number of landfills for which biocover has been implemented have increased to 22 in total in 2020, of which 12 is awaiting final approval (DEPA, 2021; Kjeldsen & Scheutz, 2016; Mønster et al., 2015; Pedersen et al, 2012).

A quantitative overview of the source category is provided in Table 7.2.1 presenting the amounts of landfilled waste, the annual gross emissions of CH₄, the recovered CH₄ in terms of collected biogas at the landfill sites used for energy production, the amount of CH₄ oxidised in the top layers and the resulting net CH₄ emissions. The CH₄ emission from the Danish landfills has decreased 65.1 % from 1990 to 2020.

A full time series (1990-2020) of these data are shown in Annex 3F, Table 3F-2.2.

Table 7.2.1 Annual amounts of total deposited waste, deposited waste with a content of organic degradable carbon, gross methane emissions, recovered methane collected for biogas production, oxidised methane in the top layer and resulting net methane emissions from the Danish SWDS.

Year	Landfilled waste kt	landfilled waste containing organic degradable carbon kt	Gross methane emission kt CH ₄	Recovered methane kt CH ₄	Methane oxidised in the top layers kt CH ₄	Net methane emission	
						kt CH ₄	kt CO ₂ eqv.
1990	3 190	1 128	68.8	0.5	6.8	61.5	1 536
1995	1 969	776	66.8	7.6	5.9	53.2	1 331
2000	1 489	601	58.9	11.3	4.8	42.9	1 073
2005	983	147	50.4	9.9	4.0	36.4	909
2010	2 487	182	40.0	5.7	3.4	30.9	772
2011	2 624	252	38.3	3.9	3.4	31.0	774
2012	2 515	251	36.8	3.7	3.3	29.7	743
2013	2 619	227	35.3	4.0	3.1	28.2	704
2014	2 575	238	33.8	3.2	3.1	27.6	689
2015	2 437	223	32.4	3.4	2.9	26.1	653
2016	2 946	239	31.1	3.6	2.8	24.8	620
2017	2 211	253	29.9	3.6	2.6	23.7	593
2018	2 409	246	28.7	3.1	2.6	23.1	576
2019	2 721	209	27.6	3.8	2.4	21.4	534
2020	2718	200	26.3	2.5	2.4	21.5	537

The yearly methane emission is a function of the type and amount of degradable organic waste deposited (Table 7.2.2 and 7.2.3). The net methane emission results from the gross emission minus the amount of recovered methane collected for bioenergy production minus the amount of methane

oxidised in the top layers of the landfills (Eq. 7.2.7). The decreasing trend in the net CH₄ emission is explained by an exponential decrease over time according to first order decay kinetics (Eq. 7.2.4) and a significant decrease in the amount of degradable organic waste deposited at landfills in Denmark (cf. Table 7.2.3 and 7.2.6 and Annex 3F, Table 3F-2.2 and Table 3F-2.3).

7.2.2 Methodological issues

The estimation of CH₄ emission from Danish SWDSs is based on a First Order Decay (FOD) model, with good quality country-specific activity data on current and historical waste disposal at SWDS, equivalent to the IPCC Tier 2 methodology (IPCC, 2006). The model calculations are performed using national statistics on landfill waste categories reported in the national waste statistics. Activity data are based on allocation of the old ISAG, and the new waste reporting system according to the European waste codes, into 18 waste types characterised by individual content of degradable organic matter and half-life's as provided in Table 7.2.2.

The degradation of a deposited waste type of quantity N is modelled according to first order kinetics. The mathematical formulation of this type of exponential decay is

$$\frac{dN}{dt} = -k \cdot N \quad \text{Eq. 7.2.1}$$

where k is the decay constant. Equation 7.2.1 can be solved for the simple case of a momentarily single deposition at time t (W_i) yielding:

$$N(t) = W_i \cdot e^{-k \cdot t} \quad \text{Eq. 7.2.2}$$

where k relates to the half-life for the content of degradable organic carbon (DOC) in the bulk waste, as:

$$t_{1/2} = \frac{\ln 2}{k} \Rightarrow k = \frac{\ln 2}{t_{1/2}} \quad \text{Eq. 7.2.3}$$

The content of degradable organic carbon (DOC_i), half-life times ($t_{1/2}$) and the corresponding methane generation constants (k) are provided in Table 7.2.2.

Table 7.2.2 Half-life times ($t_{1/2}$), degradation rates constants (k) and content of degradable organic matter (DOC_i) according to 18 waste type, of which 11 are characterised as inert*.

Waste type ¹	DOC_i , [%, ww] ²	$t_{1/2}$, [yr, ww] ³	k , [yr ⁻¹ , ww]
Food	15	4	0.17
Paper and cardboard	40	12	0.06
Wood	43	23	0.03
Plastic*	0		
Textile. fur and leather	24	12	0.06
Biodegradable garden waste	20	7	0.10
Chemicals. inert*	0		
Electric & Hazardous*	0		
Glass*	0		
Metal*	0		
Scrap vehicles*	0		
Demolition	4	23 ⁴	0.03
Soil & Stone*	0		
Particulate matter and dust*	0		
Sludge. inert*	0		
Sludge. Degradable	15 ⁵	12	0.06
Ash & Slag*	0		
Other not combustible waste*	0		

¹Waste types marked "*" are characterised as being inert, meaning that these fraction do not decompose, i.e. $DOC_f = 0$.

²Default IPCC, 2006, Vol. 5, Chapter 2, Table 2.4.

³Default IPCC, 2006, Vol. 5, Chapter 3, Table 3.4. Sludge deposited of at landfills is normally the end product from anaerobic digestion with a lower degradation rate than that of undigested sludge and the default value for slowly degrading waste (paper, textiles) is considered more suitable for Danish digestate.

⁴For demolition waste, the degradable fraction is assumed to be wood and the half-life for wood is therefore used.

⁵Default IPCC, 2006, Vol. 2, Chapter 2, Table 2.5 and 2.6.

The amount of generated methane decreases exponentially over time according to first order decay kinetics of the content of degradable organic carbon in the deposited waste.

At a given year (t) the amount of degradable organic carbon ($DDOC_m(t)$) which decomposes is a result of accumulated contributions from all former years deposit of waste ($W(x)$), where x is year since depositing. The residue of organic matter, i.e. decomposable DOC, left from waste deposited at landfill sites x years ago, is calculated using the exponential decomposition rule (Eq. 7.2.4).

$$DDOC_m(t) = W_i \cdot DOC_i \cdot DOC_f \cdot MCF + DDOC_m(t-1) \cdot e^{-k} \quad \text{Eq. 7.2.4}$$

where the methane conversion factor, MCF , is set to the default value of 1 for managed SWDS corresponding to the situation in Denmark (page 3.14, IPCC 2006). DOC_i is the mass fraction of degradable organic carbon in the deposited waste types (Table 7.2.2), and DOC_f represents the fraction of the degradable organic carbon that will decompose at the SDWS. For Denmark the default DOC_f value is used, i.e. 0.5 (IPCC 2006, page 3.13).

Eq. 7.2.4 assumes that the deposition of degradable organic carbon takes place momentarily once a year and just after the time t , where t is defined as whole years (integer: $t=1,2,\dots$), so Eq. 7.2.4 consists of two overall contributions that may be expressed as

$$DDOC_m(t) = \text{New deposit} + \text{Remaining part of former years deposit}$$

The total amount of degraded organic matter during year t ($DDOCm_{decomp_T}$) is assumed to be equal to the degradation during year t of the organic matter that was deposited at the beginning of the year ($DDOCm(t-1)$):

$$DDOCm_{decomp_T} = DDOCm(t-1) \cdot (1 - e^{-k}) \quad \text{Eq. 7.2.5}$$

Based on Equation 7.2.4 and 7.2.5 it is possible to calculate the degraded amount of organic matter in a step wise manner based on last year result. The degraded amount of organic matter is assumed to generate the CH_4 as described by

$$CH_4_{generated_T} = DDOCm_{decomp_T} \cdot F \cdot 16/12 \quad \text{Eq. 7.2.6}$$

where F , which is the fraction of methane in the gas from landfills, is set equal to 0.5 (IPCC, 2006) and 16/12 is the conversion factor from units of C to CH_4 .

For deriving the net emissions, the amount of recovered or collected methane as well as the amount of oxidised methane in the SWDS top layers needs to be subtracted from the generated methane:

$$CH_4_{Emission} = \left(\sum_x CH_4_{generated_{k,T}} - R_T \right) \cdot (1 - OX_T) \quad \text{Eq. 7.2.7}$$

where $CH_4_{Emissions}$ is the methane emitted in year T , in units of kt, T is the inventory year, x is the waste category or type. R_T is the amount of recovered CH_4 at the Danish disposal sites, which are used for energy production. The Danish Energy Agency registers the biogas amounts recovered at disposal sites in energy units (TJ) (DEA, 2020b). The amount of gas in energy unit is converted to volume of gas using the net calorific value of 15.19 MJ per Nm^3 (DGC, 2009; Vattenfall, 2010; Verdo, 2011). As for the FOD model, the content of CH_4 in the gas recovered is estimated to 41 % and the density of CH_4 is 0.678 kg per m^3 .

OX_T is the assumed oxidation of CH_4 in the top layer. The amount oxidised is uncertain and varies according to SWDS characteristics and management practices. For the Danish model an oxidation factor (OX) of 0.1 used; i.e. the default value for industrialised countries with well-managed disposal sites (IPCC, 2006).

The amount of CH_4 recovered, $R(t)$, is calculated as:

$$R_T = \frac{B \cdot 0.41 \cdot 0.678 \text{ kg/m}^3}{15.19 \text{ MJ/m}^3} \quad \text{Eq. 7.2.8}$$

where B is the collected amount of biogas as reported by the DEA in units of MJ. The CH_4 recovered is reported in Table 7.2.1 and 7.2.6 in units of kt.

7.2.3 Model results and activity data

The amounts of waste deposited are registered and published in the national ISAG and new waste system (www.ads.mst.dk) databases and have been allocated into 18 waste types as presented in Table 7.2.3 and in Annex 3F, Table 3F-2.3.

Table 7.2.3 Waste amounts according to eighteen waste types of which eleven* represents inert waste fractions, kt.

Waste types	1990	1995	2000	2005	2010	2015	2016	2017	2018	2019	2020
Food	112	52	26	5	1	0.4	0.3	0.3	0.2	0.1	0.1
Paper and cardboard	180	84	43	8	3	4	3	2	3	2	2
Wood	201	261	255	3	7	7	6	3	4	2	2
Plastic*	27	14	9	5	7	5	4	3	3	2	2
Textile, fur and leather	5	3	2	1	3	4	3	2	3	2	2
Biodegradable garden waste	136	65	35	7	7	5	1	0.01	0.02	0.41	0.22
Chemicals, inert*	8	5	4	1	1	2	0.3	1	1	1	0
Electric & Hazardous*	1	0.3	1	84	3	0.11	0.2	1	1	1	1
Glass*	37	19	11	5	5	5	4	3	3	2	2
Metal*	184	128	107	78	179	93	65	78	86	51	47
Scrap vehicles	105	64	49	49	21	0.005	0	0	0	0	0
Demolition, inert*	283	175	132	87	136	194	205	232	223	192	183
Soil & Stone*	466	309	271	174	1978	2019	2534	1782	1979	2386	2425
Particulate matter and dust*	32	0.0	0.3	0.1	3	3	5	4	5	3	2
Sludge, inert*	91	44	25	11	3	7	6	6	6	5	5
Sludge, degradable	211	136	107	38	25	9	21	13	14	11	11
Ash & Slag*	466	145	9	34	48	34	29	30	24	20	18
Other not combustible waste*	646	465	403	396	56	48	60	49	54	42	17
Total degradable	1128	776	601	147	182	223	239	253	246	209	200
Total inert	2062	1193	888	836	2305	2214	2707	1958	2162	2512	2518
Total	3190	1969	1489	983	2487	2437	2946	2211	2409	2721	2718

Data on the amounts of solid waste deposited at managed solid waste disposal sites, in the old database ISAG database (1990-2009) and the new waste data system (2010-2020), are reported by the Danish Environmental Protection Agency (DEPA). The ISAG data system provides landfill data for the years 1994-2009 (DEPA, 1996a, 1998a, 1999a, 2001a, 2001b, 2002a, 2004a, 2004b, 2005a, 2006a, 2006b, 2008, 2010a, 2011a,) and the new waste data system provides data for 2011-2020 (DEPA, 2013a, 2014, 2015, 2016, 2017, 2018, 2019, 2020a, 2020b). Data have been provided by the Danish EPA (Table 7.8.1).

For the years 2010-2020 allocations has been performed according to the reported European waste codes (Statutory Order no. 1309, 18/12/2012) in the new waste data system (cf. Annex 3F, Table 3F-2.4 and 3F-2.5).

For the old ISAG database, 1994-2009 (DEPA, 1996a, 1998a, 1999a, 2001a, 2001b, 2002a, 2004a, 2004b, 2005a, 2006a, 2006b, 2008, 2010a, 2011a, 2014, 2015), have been analysed in depth and specific waste fractions have been allocated according to the 18 defined waste types as provided in Table 7.2.3 (and Annex 3F, Table 3F-2.3).

Waste characterization data for the year 1985 (DEPA, 1993; DEPA, 1997) and information on the total amount of waste deposited at SWDSs in 1970 reported by the Danish EPA in 1993 (DEPA, 1994) was used in the back calculation of the time series from 1994-1985.

Data for 1971-1984 have been determined by assuming a linear development between 1970 and 1985, while data for the period 1940-1969 are kept constant at the 1970 level.

Waste amounts for the whole time series, i.e. 1940- 2020, categorised, allocated and divided into 18 waste types as described above, are provided in

Annex 3F, Table 3F-2.3 and Table 3F-2.4. Corresponding annual fractional distributions of the total amount of deposited waste according to type, respecting mass conservation, is presented in units of mass fractions in Table 7.2.4 (for the whole time series the reader is referred to Annex 3F, Table 3F-2.5).

Table 7.2.4 Fractional distribution of reported waste, according to the old ISAG and the new waste data system (EWC), allocated according to the 18 waste types.

Waste types	1990	1995	2000	2005	2010	2015	2016	2017	2018	2019	2020
Food	3.5	2.6	1.8	0.5	0.0	0.0	0.0	0.0	0.0	0.0	0.0
Paper and cardboard	5.7	4.3	2.9	0.8	0.1	0.2	0.1	0.1	0.2	0.2	0.1
Wood	6.3	13.3	17.1	0.3	0.3	0.5	0.4	0.2	0.2	0.3	0.2
Plastic*	0.8	0.7	0.6	0.5	0.3	0.3	0.4	0.2	0.2	0.2	0.1
Textile. fur and leather	0.2	0.2	0.2	0.1	0.1	0.2	0.2	0.1	0.2	0.2	0.1
Biodegradable garden waste	4.3	3.3	2.4	0.7	0.3	0.3	0.1	0.2	0.2	0.2	0.0
Chemicals. inert*	0.2	0.2	0.2	0.1	0.0	0.0	0.0	0.0	0.0	0.1	0.0
Electric & Hazardous*	0.02	0.02	0.05	8.5	0.1	0.1	0.0	0.0	0.0	0.0	0.0
Glass*	1.2	0.9	0.7	0.5	0.2	0.2	0.1	0.2	0.2	0.2	0.1
Metal*	5.8	6.5	7.2	7.9	7.2	5.9	5.3	4.7	6.3	3.8	2.2
Scrap vehicles*	3.3	3.3	3.3	5.0	0.9	0.7	0.1	0.0	0.0	0.0	0.0
Demolition	8.9	8.9	8.9	8.9	5.5	7.0	7.9	7.3	8.0	8.0	7.0
Soil & Stone*	14.6	15.7	18.2	17.7	79.5	76.2	78.5	81.7	79.2	82.8	86.0
Particulate matter and dust*	1.0	0.0004	0.02	0.01	0.1	0.2	0.3	0.3	0.2	0.1	0.2
Sludge. inert*	2.8	2.3	1.7	1.1	0.1	0.3	0.4	0.3	0.3	0.3	0.2
Sludge. degradable	6.6	6.9	7.2	3.8	1.0	1.4	1.2	0.6	0.5	0.3	0.7
Ash & Slag*	14.6	7.4	0.6	3.4	1.9	1.7	1.5	1.5	1.8	1.4	1.0
Other waste. inert***	20.3	23.6	27.1	40.3	2.3	4.8	3.5	2.4	2.4	2.0	2.0

*inert waste fractions, **50 percent is assumed inert and the 50 % mixed degradable waste which have been allocated according to the relative amounts of degradable waste types of each reporting year.

While Table 7.2.4 presents the fractional distribution of 18 identified waste types of known DOC_i values, corresponding methane generation potentials are presented in Table 7.2.5.

Table 7.2.5 Methane generation potential for each of the 18 waste types, kt CH₄ per kt waste.

Waste types	$L_{o,i}/W_i$
Food	0.05
Paper and cardboard	0.133
Wood	0.143
Plastic*	0
Textile. fur and leather	0.08
Biodegradable garden waste	0.067
Chemicals, inert*	0
Electric & Hazardous*	0
Glass*	0
Metal*	0
Scrap vehicles*	0
Demolition	0.013
Soil & Stone*	0
Particulate matter and dust*	0
Sludge, inert*	0
Sludge, Degradable	0.05
Ash & Slag*	0
Other waste, inert*	0

The content of degradable organic matter, DOC_i values, in each waste type is shown separately in Table 7.2.2 and has been kept constant for the whole time series. The methane generation potential per unit waste type i is obtained from equation 7.2.9:

$$\frac{L_{o,i}}{W_i} = DOC_f \cdot MCF \cdot F \cdot \frac{16}{12} \cdot DOC_i$$

↓

Eq. 7.2.9

$$\frac{L_{o,i}}{W_i} = 0.33 \cdot DOC_i$$

where the yearly decomposable fraction of the organic carbon content, DOC_f , are set equal to 0.5, the methane conversion factor, MCF are set equal to 1 and the volume fraction of CH_4 in generated landfill gas, F , are 0.5 (IPCC, 2006). The methane generation potentials according to waste types are reported in Table 7.2.5.

The annual amounts of the waste types (Table 7.2.3) and their emission generation potentials per mass unit (Eq. 7.2.9 and Table 7.2.5) are used to calculate the deposited CH_4 generation potential and the actual generated CH_4 emission from the annually amount of deposited waste (Eq. 7.2.6).

Figure 7.2.1 shows the time trend in annual amounts of deposited methane generation potential for each of the deposited waste type per year.

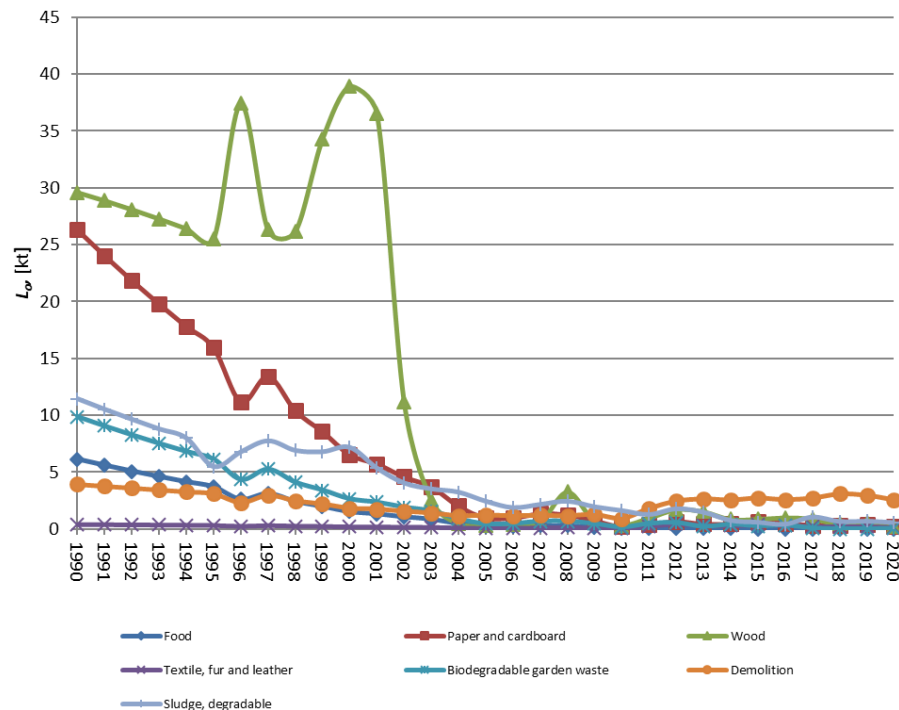

Figure 7.2.1 Annual amounts of deposited methane generation potential per waste type.

Figure 7.2.1 shows that the amounts of yearly deposited methane generation potential has decreased significantly in the period from 1990 to 2005. Only a fraction of the deposited methane generation potential is released per year; i.e. a function of the degradation rate constants of the individual waste types, the content of degradable organic carbon and according to first order degradation kinetics for each waste type (Eq. 7.2.1 to 7.2.6 and Table 7.2.2). The seemingly significant fluctuations in the yearly amounts of deposited methane generation potentials become insignificant when looking at the annual implied emission factors, calculated from the net methane emission per waste type divided by the accumulated amount of decomposable organic matter per waste type (Table 7.2.6), as illustrated in Figure 7.2.2.

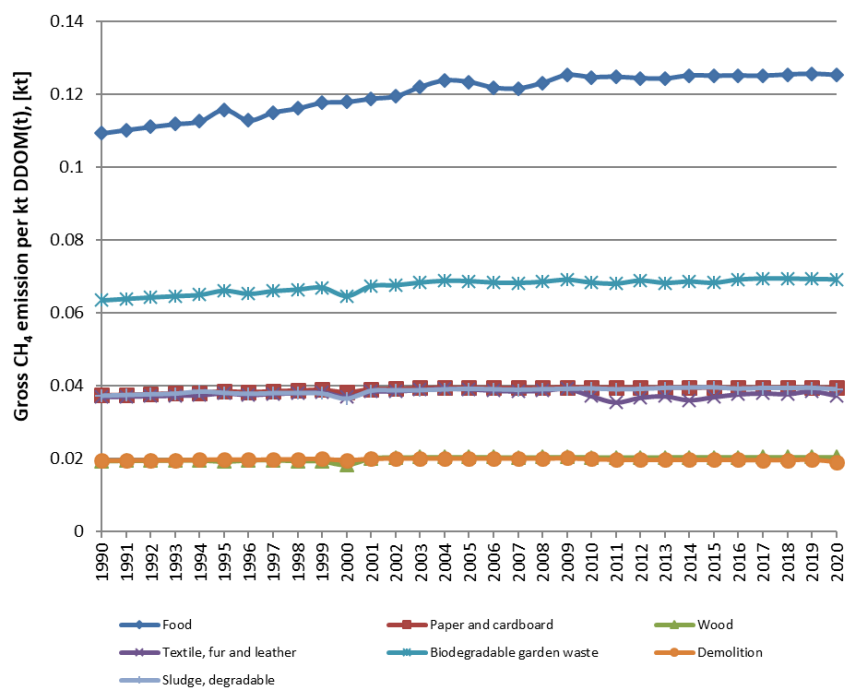

Figure 7.2.2 Annual gross implied emission factors for each waste type.

Figure 7.2.2 shows the time trend in the gross implied methane emission factor calculated as the gross methane emission divided by the accumulated (or remaining) amount of degradable organic carbon within each waste type (the sum across waste types are provided in Table 7.2.6). As may be observed from comparing Figure 7.2.2 with Figure 7.2.1, food waste has the highest gross methane emission factor and one of the lowest yearly methane generation potentials. The highest methane emission factor (Figure 7.2.2) for food waste throughout the time series may be explained by the lowest half-life (high CH₄ release rate) and content of degradable organic carbon for food waste compared to other waste types. Still, the yearly amounts of deposited food waste is low and so is the yearly methane generation potential (Eq. 7.2.9).

The net CH₄ emission (Eq. 7.2.7) is obtained upon subtraction of the recovered CH₄, utilized for energy production at some of the sites, and the amount of oxidized methane in the SWDS top layers from the gross methane emission. The annual total amounts of deposited waste, accumulated degradable organic waste, degraded organic matter and the calculated CH₄ emissions are presented in Table 7.2.6.

Table 7.2.6 Waste deposited, total organic degradable matter, amounts of annual degraded organic matter and resulting CH₄ emissions for 1990-2020.

Year	Total Deposited Waste	Accumulated amount of decomposable DDOCm Eq. 7.2.4	Annual amount of degraded DDOCm Eq. 7.2.5	Annual deposited CH ₄ potential	Annual Gross CH ₄ emission Eq. 7.2.6	Recovered methane	Annual net emission before oxidation	Annual net emission after oxidation Eq. 7.2.7	Implied emission factors		
	[kt]			[kt CH ₄]						kt CH ₄ /kt waste	kt CH ₄ /kt DDOCm
1990	3190	2063	92.9	87.7	69	1	68	61.5	0.019	0.030	
1995	1969	2063	91.9	60.2	67	8	59	53.2	0.027	0.026	
2000	1489	2009	86.4	58.9	59	11	48	42.9	0.029	0.021	
2005	983	1681	72.7	5.7	50	10	40	36.4	0.037	0.022	
2010	2487	1395	58.7	3.3	40	6	34	30.9	0.012	0.022	
2015	2437	1176	48.1	5.6	32	3	29	26.1	0.011	0.022	
2016	2946	1138	46.2	5.2	31	4	28	24.8	0.008	0.022	
2017	2211	1100	44.4	5.3	30	4	26	23.7	0.011	0.022	
2018	2409	1064	42.7	4.7	29	3	26	23.1	0.010	0.022	
2019	2721	1028	41.0	4.8	28	4	24	21.4	0.008	0.021	
2020	2718	994	39.4	3.7	26	2	24	21.5	0.008	0.022	

The total waste amount in the second column of Table 7.2.6 is the sum of the amounts of the 18 different waste types (Table 7.2.3). The total waste amount is reported as the activity data for the Annual Municipal Solid Waste (MSW) at SWDSs in the CRF Table 5.A.

The implied emission factors (IEFs) in the second last column in Table 7.2.6 reflects an aggregated emission factor calculated as the net methane emission divided by the total amount of waste deposited in the current year and corresponds to the reported IEFs in the CRF Table 5.A. However, the IEF values in the last column in Table 7.2.6 represents more appropriate IEF values, i.e. calculated as the net methane emission divided by the total amount of decomposable degradable organic matter, DDOCm. The DDOCm are provided in the third column in Table 7.2.6.

The trend in the total amount of decomposable DOC accumulated at the Danish landfills and amount annual degraded organic matter, provided in the third and fourth column in Table 7.2.6, shows that the percent degraded decreases slightly from 4.5 % in 1990 to 4.0 % in 2020.

Figure 7.2.3 visualises the trend in the annual deposited methane potential, the annual gross emission, the annual amount of recovered methane and the net methane emission with and without methane oxidation.

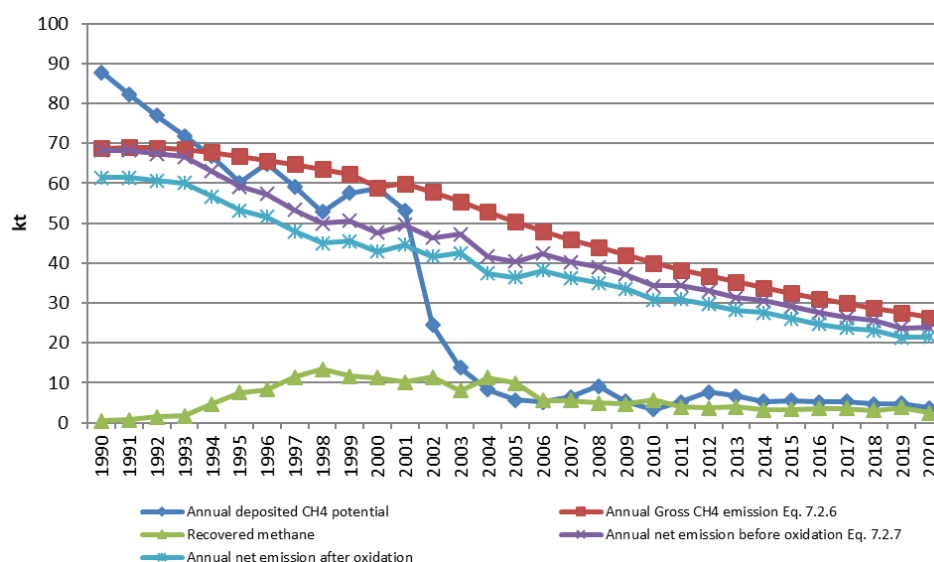

Figure 7.2.3 Time trend in the annual deposited methane potential, gross methane emission, recovered methane, annual net methane emission before and after oxidation.

In total, a reduction in the net methane emission from 1990 to 2020 of 65.1 % is observed. This reduction in the methane emission is accompanied by a decrease in the accumulated amount of decomposable degradable organic matter (DDOC_m) of 51.8 % and in the annual amount of deposited methane potential, which is reduced by 95.7 % 2020 compared to 1990. The fluctuation in the net methane emission is explained by the fluctuations in the annual amount of deposited methane potential and the amount of recovered methane.

7.3 Biological treatment of solid waste

This sector provides an overview of the Danish greenhouse gas emission from the CRF source category 5.B *Biological treatment of solid waste*, which consists of the sub-categories 5.B.1 *Composting* and 5.B.2 *Anaerobic digestion at biogas facilities*.

7.3.1 Composting

This section covers the sub-category of biological treatment of solid wastes called composting. Greenhouse gasses that are emitted from this process are CH₄ and N₂O as presented in Table 7.3.1. CO₂ emissions from compost production are biogenic and not reported in the inventory. The full time series for emissions related to composting are shown in Annex 3F, Table 3F-3.1.

Table 7.3.1 National emissions from composting, t.

	1990	1995	2000	2005	2010	2015	2016	2017	2018	2019	2020
CH ₄	1068	1448	2485	2635	2960	3038	3040	3291	3328	3449	3406
N ₂ O	75	101	191	189	213	218	219	239	239	246	244

The whole time series is visualised in figure 7.3.1 showing a steady increase in the CH₄ emissions correlated to the pattern in the AD excluding sludge explained by the minor size of the CH₄ EF value for sludge compared to the remaining three bio-waste types treated at the Danish composting plants (see Table 7.3.4). The N₂O emissions, however, are explained by the significant increase in the amount of sludge being composted in the period 1999 to 2003 as shown in Figure 7.3.2 (and Annex 3F, Table 3F-3.2) and a high N₂O EF value for sludge compared to the remaining bio-waste types (Table 7.3.4).

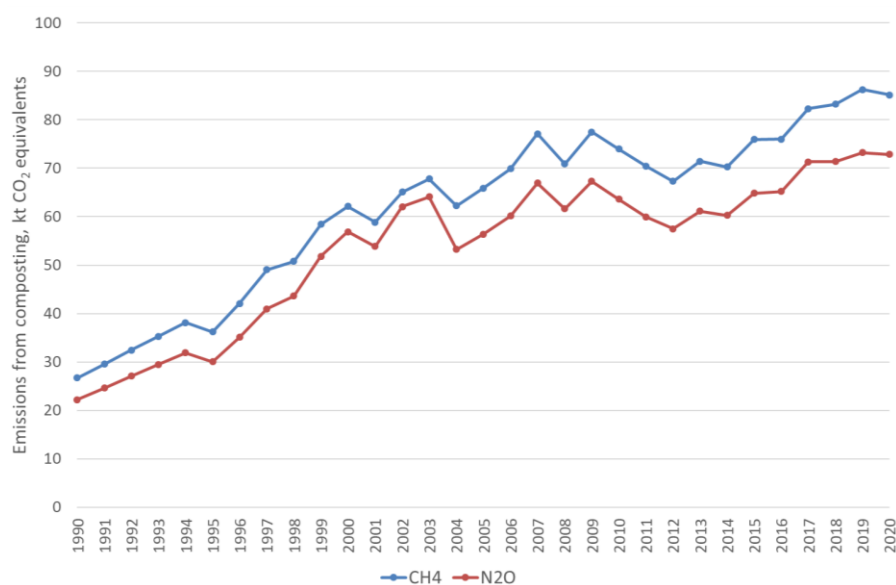

Figure 7.3.1 Time trend for N₂O and CH₄ emissions from composting plants.

For both methane and nitrous oxide emission, garden and park waste (GPW) is the main contributor contributing with 86 % and 89 % in 1990 and 90 % and 91 % in 2020. For the trend an increase of a factor 3.2 and 3.3 for CH₄ and N₂O, respectively, is observed in 2020 compared to 1990 (c. Annex 3F, Table 3F-3.1).

Methodological issues

Emissions from composting have been calculated using both IPCC default emission factors and other emission factors considered country-specific, corresponding to a hybrid tier 1/tier 2 methodology.

In Denmark, composting of solid biological waste includes composting of:

- garden and park waste (GPW)
- organic waste from households and other sources
- sludge
- home composting of garden and vegetable food waste.

In 2017, 150 composting facilities treated only garden and park waste (type 2 facilities), nine facilities treated organic waste mixed with GPW or other organic waste (type 1 facilities) and 10 facilities treated GPW mixed with sludge and/or “other organic waste” (type 3 facilities). 92 % of these facilities consisted entirely of windrow composting, which is a simple technology composting method with access to only natural air. It is assumed that all facilities can be considered using windrow composting (Petersen & Hansen, 2003).

Composting is performed with simple technology in Denmark; this implies that temperature, moisture and aeration are not consistently controlled or regulated. Temperature is measured but not controlled, moisture is regulated by watering the windrows in respect to weather conditions and aeration is assisted by turning the windrows (Petersen & Hansen, 2003).

During composting, a large fraction of the degradable organic carbon (DOC) in the waste material is converted into CO₂. Even though the windrows are occasionally turned to support aeration, anaerobic sections are inevitable

and will cause emissions of CH₄. In the same manner, aerobic biological digestion of N leads to emission of N₂O (IPCC, 2006).

Activity data

All Danish waste treatment plants are obligated to statutory registration and reporting of all waste entering and leaving the plants. All waste streams are weighed, categorised with a waste type and a type of treatment and registered to the ISAG waste information system, which contain data for 1995-2009 (ISAG). Activity data for 2010-2020 have been received from the Danish EPA. For 2010-2020, activity data from the new waste reporting system (www.ads.mst.dk), on the waste types GPW, organic waste from households and other sources and sludge, were multiplied by the fraction of the bio-waste types being composted derived from plant level data on bio-waste going to composting and bio-gasification respectively (DEPA, Ellen Nissen, personal communication). AD for each bio-waste type, for the whole time series, are provided in Annex 3F, Table 3F-3.2. As activity data are not available as dry matter, it is not reported in the CRF, as the CRF does not allow to report using wet amounts.

Figure 7.3.2 illustrates the composted amount of waste divided in the four categories mentioned earlier.

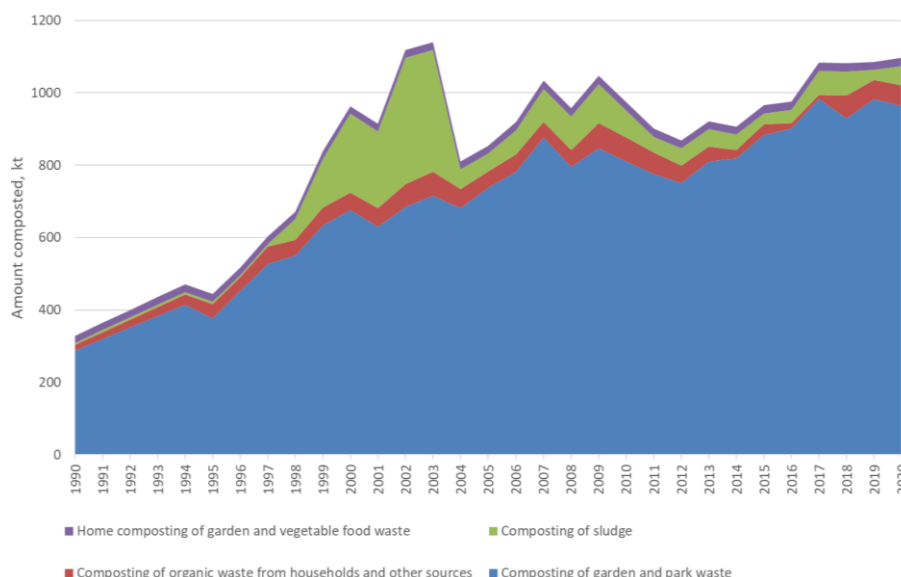

Figure 7.3.2 Trends in the national amount of composted waste.

Activity data for the years 1995-2009 are collected from the ISAG database for the categories: GPW, organic waste from households and other sources and sludge.

For sludge, the activity data for 1995-2020 were collected from the Danish waste statistics, while activity data in the period 1990-1994 were interpolated based on known sludge be composted in 1985 (DEPA, 1999c). The Danish legislation on sludge (DEPA, 2006c) was implemented in the summer of 2003. This stated that composted sludge must only be used as a fertilizer on areas not intended for growing foods of any kind for at least 2-3 years. This restriction caused the amount of composted sludge to drop drastically from 2003 to 2004.

The amount of organic waste from households composted in the years 1990-1994 is estimated by multiplying the number of facilities treating this type

of waste with the average amount composted per facility in the years 1995-2001 (2.6-3.8 kt per facility per year). The following Table 7.3.2 shows the number of composting sites divided in the three types, where type 1 is mainly receiving source separated organic waste, type receive only garden and park waste, while type 3 receive garden park waste in combination with other organic waste types (Petersen, 2001 and Petersen & Hansen, 2003).

Table 7.3.2 Number of composting facilities in the years 1990-2001.

Facility type	1990	1991	1992	1993	1994	1995	1996	1997	1998	1999	2000	2001
Type 1	5	6	7	8	9	13	14	13	14	13	11	9
Type 2	38	54	70	86	102	113	108	99	102	111	115	123
Type 3	1	2	2	3	4	9	9	11	10	10	7	10
Total	44	62	79	97	115	136	133	126	130	139	138	149

Type 1 waste treatment sites normally includes biogas-producing facilities, but these have been excluded in Table 7.3.1.

The ISAG activity data for composting of garden and park waste (GPW) include wood chipping. Compost data for GPW provided by Petersen (2001) and Petersen & Hansen (2003) show that for 1997-2001, wood chipping accounts for about 3 % of the total chosen ISAG activity data for GPW. Activity data for GPW for the years 1985-1994 are estimated by extrapolating the trend.

The last waste category involved in composting is home composting of garden waste and vegetable waste. The activity data for this category are known from Petersen & Kielland (2003) to be 21.4 kt in 2001. It is assumed that the following estimates made by Petersen & Kielland (2003) are valid for all years 1990-2020.

- 28 % of all residential buildings with private gardens (including summer cottages) are actively contributing to home composting
- 14 % of all multi-dwelling houses are actively contributing to home composting
- On average, 50 kg waste per year will be composted at every contributing residential building
- On average, 10 kg waste per year will be composted at every contributing multi-dwelling house.

Multi-dwelling houses include apartment buildings. It is very un-common for people in these types of buildings to compost their bio waste and the average amount of composted waste is therefore lower in spite of the higher number of residents. The total number of occupied residential buildings, summer cottages and multi-dwelling houses are found at the Statistics Denmark's website. The calculated activity data for composting are shown in Table 7.3.3 and in Annex 3F, Table 3F-3.2.

Table 7.3.3 Activity data composting, kt.

	1990	1995	2000	2005	2010	2015	2016	2017	2018	2019	2020
Composting of garden and park waste	288	376	677	737	811	884	901	983	929	983	964
Composting of organic waste from households and other sources	16	40	47	45	65	29	16	11	64	53	56
Composting of sludge	5	7	218	50	75	30	36	67	67	27	54
Home composting of garden and vegetable food waste	20	21	21	22	23	23	23	23	23	23	23
Total	329	444	963	854	974	966	976	1084	1082	1086	1096

Emission factors

The emissions from composting strongly depend on both the composition of the treated waste and on process conditions such as aeration, mechanical agitation, moisture control and temperature pattern (Amlinger et al., 2008).

The emission factors stated in Table 7.3.4 and 7.3.5 are considered the best available for the calculation of Danish emissions from composting and are provided in kg emissions/kt wet weight bio-waste.

Table 7.3.4 CH₄ emission factors for composting [kg/t ww].

	Garden and park waste (GPW)	Organic waste from households and other sources	Sludge	Home composting of garden and vegetable food waste
Unit	kg per t	kg per t	kg per t	kg per t
CH ₄	3.19	4.00	0.22	4.20
Source	Andersen et al. (2010)	IPPC, 2006	DEPA, 2013b; Kirkeby et al., 2005	Andersen et al., 2011

Methane emission factors

The methane emission factors, $EF(CH_4)$, for composting of GPW, sludge and for home composting, are calculated according to equation 7.3.1:

$$EF(CH_4) = E(CH_4-C) \cdot 16/12 \cdot DOC \cdot f_{degraded} \cdot (1 - f_{moisture}) \cdot 1000 \text{ kg/t} \quad \text{Eq. 7.3.1}$$

where the emissions factor, $EF(CH_4)$, is provided in units of [kg CH₄/t ww bio-waste, $E(CH_4-C)$ is emissions provided in units of [kg CH₄-C/kg dw degraded C], DOC is the content of degradable organic carbon provided in units of [kg DOC/kg dw bio-waste], $f_{degraded}$ is the fraction of DOC that are degraded during the composting process and $f_{moisture}$ is the moisture content in composted waste type. DOC is quantified as the content of volatile solids (VS) multiplied by the carbon content of the VS.

Garden and park waste

Data from Andersen et al. (2010) were applied to derive at an $E(CH_4)$ value of 0.027 kg CH₄-C/kg dw degraded C, a DOC value of 0.26 kg DOC/kg dw bio-waste, $f_{degraded}$ equals 0.56 and the dry matter content equals 0.61 kg dw/kg ww resulting in an $EF(CH_4)$ value of 3.19 kg CH₄/t ww.

Organic waste from households and other sources

For composting of organic waste from households and other sources, the EF value is set equal to the default value of 4 kg CH₄/tonne ww organic waste (Table 4.1 in Chapter 4, IPCC, 2006).

Sludge

The $E(CH_4)$ value is set equal to 0.0030 kg CH₄-C/kg dw degraded C in sludge, which is an average of reported values for composting of anaerobic digested and secondary sludge (Table 4.6, page 177, DEPA, 2013b).

DOC is derived from reported value on the VS content. DEPA (2013b) provides numbers for loss on ignition (VS) prior to composting in the range of 55 to 70% for anaerobic digested/not digested secondary sludge. As sludge management may consist of anaerobic digestion and composting as post-treatment of the digestate (DANVA, 2009; DEPA, 2013c; Glæsner et al., 2016; Zeng et al., 2016), an average value of 0.625 multiplied by a carbon content of 0.5 result in a DOC value 0.313 kg DOC/kg dw sludge. This value is comparable to the reported value of 0.350 kg DOC/kg dw sludge based on an

assumption of 70% of loss on ignition (equal to the VS content) and 50% of the VS is carbon (Friedrich et al., 2002; Kirkeby et al., 2005). We applied the highest DOC value of 0.350 kg DOC/kg dw sludge.

The amount of degraded carbon is reported as 50% of *DOC* for anaerobic digested sludge and 65% for secondary (non-digested) sludge. An average value of 0.575 is applied.

The dry matter content of sludge before composting is in the range of 20-30 % and set equal to an average value of 27.5 % for digested and non-digested sludge (Table 4.6, page 177, DEPA, 2013b). The National waste statistics reports a dry matter content of 33% in sludge applied on agricultural soils (e.g. DEPA, 2020).

As a result, an $EF(CH_4)$ value 0.22 kg CH_4 /t ww is applied in this year's NIR.

The updated $EF(CH_4)$ is significant lower than the former value of 0.41 kg CH_4 /t ww, which is explained by the corrected dry matter content which is reduced from 0.75 to 0.275 and the fraction of DOC being degraded which is reduced from 1 to 0.575.

Home composting of garden and vegetable food waste

Values of $E(CH_4-C)$ for home composting ranges from 0.6 to 4.2 (Table 5 in Andersen et al., 2011). In the inventory, the highest value reported in Andersen et al. (2011) is applied in the calculations.

All *DOC* values are within the range of 25-50%, and comparable to the corresponding average value of 0.375 kg DOC/kg dw bio-waste (Table 4.1 in Chapter 4, IPCC, 2006).

The default dry matter content, $1-f_{moisture}$ for the composted waste is 40% or [0.4 kg dw/kg ww] based on a moisture content of 60% in wet waste (Table 4.1 in Chapter 4, IPCC, 2006). For GPW and sludge, applied values are outside the range provided in the IPCC guidelines; i.e. 0.61 and 0.275 kg dw/kg ww is applied (Andersen et al., 2010; DEPA, 2013b).

Nitrous oxide emission factors

Table 7.3.5 N_2O emission factors for composting [kg/t ww].

	Garden and park waste (GPW)	Organic waste from households and other sources	Sludge	Home composting of garden and vegetable food waste
Unit	kg per t	kg per t	kg per t	kg per t
N_2O	0.23	0.24	0.09	0.20
Source	Boldrin et al., 2009	IPPC, 2006	DEPA, 2013b; Jensen et al., 2015; DEPA, 2001	Boldrin et al. 2009

Emission factors for nitrous oxide, $EF(N_2O)$, for composting of GPW, sludge and for home composting, are calculated according to equation 7.3.2, while the default IPCC value was applied for composting of organic waste:

$$EF(N_2O) = E(N_2O-N) \cdot 44/28 \cdot N_{tot} \cdot (1-f_{moisture}) \cdot 1000 \text{ kg/t} \quad \text{Eq. 7.3.2}$$

where $EF(N_2O)$ is provided in units of [kg N_2O /kg ww bio-waste], $E(N_2O-N)$ is the emission provided in units of N_2O-N /kg dw total N, 44/28 is the

molecular weight ratio between N_2O and N_2 , N_{tot} is the total N content in the waste and $f_{moisture}$ is the moisture content in composted waste type.

Garden and park waste

The $EF(N_2O)$ were derived from an $E(N_2O-N)$ value of 0.012 kg N_2O-N /kg dw total N in central composted GPW (page 33, Table 4.3, Boldrin et al., 2009), a default nitrogen content of 2 % in dry matter, or 0.02 kg total N/kg dw GPW (IPCC, 2006) and a moisture content of 39 % This results in an emission factors of 0.23 kg N_2O per kg ww.

Organic waste from households and other sources

For composting of organic waste the default value of 0.24 kg N_2O per tonne ww waste is applied (Table 4.1 in Chapter 4, IPCC, 2006).

Sludge

For sludge, emission is reported per total N emission during composting and therefore, the EF value is calculated according to equation 7.3.3

$$EF(N_2O) = E(N_2O) \cdot 44/28 \cdot f_{N-loss} \cdot N_{tot} \cdot (1 - f_{moisture}) \quad \text{Eq. 7.3.3}$$

where $EF(N_2O)$ is provided in units of [kg N_2O /kg ww bio-waste]. The $E(N_2O-N)$ value is equal to 0.0093 kg N_2O-N /kg N loss, the N-loss set equal to 55 % of the total N content in sludge (DEPA, 2013b). The nitrogen content of sludge, N_{tot} , is equal to 4.3% of the dw sewage sludge; i.e. 0.043 kg N/kg dw sludge (Jensen et al., 2015; DEPA, 2001). The dry matter content of sludge before composting is in the range of 20-30 % and set equal to an average value of 27.5 % for digested and non-digested sludge (Table 4.6, page 177, DEPA, 2013b).

Home composting of garden and vegetable food waste

As for all waste types, the $E(N_2O-N)$ value of 0.0011 kg N_2O-N /kg total N for home composting (Boldrin et al. 2009) is multiplied by 44/28 to provide the emission in units of kg N_2O /kg total N. N_{tot} is set equal to 2 % N per dry matter, [0.02 kg N/kg dw bio-waste], (Table 4.1 in Chapter 4, IPCC, 2006). The dry matter content ($1-f_{moisture}$) in units of [kg dw/kg ww] is set equal to 0.6 (Boldrin and Christensen, 2010).

7.3.2 Anaerobic digestion at biogas plants

Biogas production in this sector covers emissions from the handling of biological waste including garden and park waste, household waste, sludge and manure.

Methane emission from biogas plants using landfill gas as feedstock is implicitly included in the CRF source category 5.A.1. *Managed Waste Disposal Sites*, as the collected biogas is monitored in terms of energy production subtracted from the yearly methane release from SWDS in Denmark (cf. Chapter 7.2).

Methane emissions from sludge-based biogas plants connected to wastewater treatment are included in the CRF category 5.D *Wastewater treatment and discharge* (cf. Chapter 7.5). Fugitive emissions of CH_4 from anaerobic digestion of sludge have been set equal to 1.3 % of the biogas production (Thomsen, 2016) as reported in the Danish Energy Statistics, and are included in Chapter 7.5.

Emissions from storage of manure are included in the agricultural sector (cf. Chapter 5).

Emissions of CH₄ from biogas plants occur from stacks and ventilation during several stages of the process, e.g. ventilation in the receiving hall of the plant, from the emergency flare and from upgrading units.

Emissions that are more significant occur from leakages in the production equipment and pipelines. These leakages are by nature very variable from plant to plant and as such difficult to quantify at a national level.

The 2006 IPCC Guidelines consider emissions from biogas plants (anaerobic digestion) as part of the waste sector. According to the 2006 IPCC Guidelines, emissions of CH₄ from such facilities due to unintentional leakages during process disturbances or other unexpected events will generally be between 0 and 10 % of the amount of CH₄ generated. In the absence of further information, use 5 percent as a default value for the CH₄ emissions (IPCC, 2006).

A Danish project measured leakages from nine biogas plants in Denmark. The results are reported in DEA (2015). Five of the plants were small farm-based plants while the other four were larger plants. The results were that the CH₄ leakage varied from nil to 10 % of the production. The largest leakage rates were detected for the larger plants. The weighted average for the nine plants was 4.2 % and the adopted emission factor, EF, set equal to 0.042 (Eq. 7.3.4).

A voluntary measurement programme was started by the industry in 2017. The voluntary programme consisted of multiple elements including the establishment of own-check programmes, leak detection and quantification of the CH₄ emission (Biogasbranchen, 2019).

In 2019, finances was allocated in the national budget to amongst other things carry out a more comprehensive measuring programme on biogas plants. The programme measured on different types of plants and the results were reported in 2021 (Gudmundsson et al., 2021).

The results are summarised in Table 7.3.6 below.

Table 7.3.6 Results from the measurement programme

Plant type	Number of plants	Sum measured CH ₄ production (kg CH ₄ /time)	Sum of measured CH ₄ emission (kg CH ₄ /hour)	Emission factor (%)
Large plants	29	26 717	505	1.9 ± 0.3
Single farm plants	15	3246	128	3.9 ± 1.0
Industrial plants	1	467	9	2.0 ± 0.4

The weighted emission factor is 2.1 % for all plants combined.

The measurements cover 64 % of the CH₄ production from these plant types. However, the plants included in the programme did volunteer and hence it cannot be guaranteed that the plants are representative for all plants in Denmark. As such, the previously determined emission factor of 4.2 % will be used for the plants not included in the measurement programme.

Therefore, the emission factor used in the inventory is a weighted emission factor of the plants covered by the measurement programme and the plants not included. For 2020, the weighted emission factor is calculated based on 36 % of the production having an emission factor of 4.2 % and the remaining 64 % having an emission factor of 2.1 % resulting in a weighted emission factor of 2.9 % in 2020.

The attention to the issue of emissions from biogas plants started in 2016/2017 and therefore the emission factor has been interpolated between 2016 (4.2 %) and 2020 (2.9 %) resulting in values of 3.9 %, 3.5 % and 3.2 % for 2017, 2018 and 2019 respectively.

The activity data and resulting emissions are estimated according to equation 7.3.4 and shown in Table 7.3.6 below.

$$CH_{4,mbb} = (E : NCV) \cdot EF_{mbb} \quad \text{Eq. 7.3.4}$$

where $CH_{4,mbb}$ is the methane emission from manure-based biogas, E is energy production included in the annual energy statistics, divided by the net calorific value (NCV) of CH_4 of 50 GJ per tonne (Morvay and Gvozdenac, 2009) and multiplied by the EF value.

Table 7.3.6 Activity data and emissions from anaerobic digestion of organic waste.

Year	1990	1995	2000	2005	2010	2015	2016	2017	2018	2019	2020
Biogas production, TJ	266	746	1442	2375	3184	3072	3281	3461	4271	5164	7899
CH_4 production, kt	5328	14 917	28 834	47 504	63 682	61 437	65 621	69 218	85 421	103 271	157 985
CH_4 emission, t	224	627	1211	1995	2675	2580	2756	2907	3588	4337	6635
CO_2 eqv, kt	6	16	30	50	67	65	69	73	90	108	166

7.4 Incineration and open burning

The CRF source category 5.C. *Incineration and open burning* includes cremation of human bodies and animal carcasses.

Incineration of municipal, industrial, clinical and hazardous waste takes place with energy recovery and therefore the emissions are included in the relevant subsectors under CRF sector 1A. For documentation, please refer to Chapter 3.2. Flaring off-shore and in refineries are included under CRF sector 1B2c, for documentation please refer to Chapter 3.5. No flaring in chemical industry occurs in Denmark.

Table 7.4.1 gives an overview of the Danish greenhouse gas emission from the CRF source category 5.C *Incineration and open burning* comprised by emission from human and animal cremations. CO_2 emissions from animal and human cremations are considered biogenic.

Year	1990	1995	2000	2005	2010	2015	2018	2019	2020
CH₄ emission from									
Human cremation, t	0.48	0.52	0.49	0.48	0.49	0.51	0.54	0.54	0.55
Animal cremation, t	0.03	0.04	0.08	0.14	0.26	0.20	0.21	0.20	0.18
Total	0.51	0.55	0.57	0.62	0.75	0.71	0.75	0.74	0.73
N₂O emission from									
Human cremation, t	0.60	0.64	0.61	0.60	0.62	0.64	0.68	0.68	0.69
Animal cremation, t	0.03	0.05	0.10	0.17	0.33	0.25	0.26	0.26	0.23
Total,	0.63	0.69	0.71	0.77	0.95	0.89	0.94	0.94	0.92
Human cremation, kt CO ₂ eqv	0.19	0.20	0.19	0.19	0.20	0.20	0.22	0.22	0.22
Animal cremation, kt CO ₂ eqv	0.01	0.01	0.03	0.06	0.10	0.08	0.08	0.08	0.07

Emissions from human cremations constituted 95 % of the sub-sectoral total in 1990 and 76 % of the total CO₂ equivalent emissions in 2020, the trend in emissions from animal cremations are the most significant with an increase of a factor 5.6 in 2020 compared to 1990. Emissions for the whole time series are provided in Annex 3F, Table 3F-4.1.

7.4.1 Human cremation

The incineration of human corpses is a common practice that is performed on an increasing part of the deceased. All Danish crematoria use optimised and controlled cremation facilities with temperatures reaching 800-850 °C, secondary combustion chambers, controlled combustion airflow and regulations for coffin materials.

Methodological issues

During the 1990s, all Danish crematoria were rebuilt to meet new standards. This included installation of secondary combustion chambers and in most cases replacement of old primary combustion chambers (Schleicher et al., 2001). All Danish crematoria are therefore performing controlled incinerations with a good burnout of the gases and a low emission of pollutants.

Following the development of new technology, the emission limit values for crematoria were lowered again in January 2011. These new standards were originally expected from January 2009 but were postponed two years for existing crematoria. Table 7.4.2 shows a comparison of the emission limit values from February 1993 and the new standard limits.

Table 7.4.2 Emission limit values, mg per Nm³ at 11 % O₂ (Schleicher & Gram, 2008).

Component	Report 2/1993	Standard terms (1/2011)
	Emission limit value mg per normal m ³ at 11 % O ₂	
CO	500	500
Other demands:		
Stack height	3 m above rooftop	3 m above rooftop
Temperature in stack	Minimum 150 °C	Minimum 110 °C
Flue gas flow in stack	8 – 20 m/s	No demands
Temperature in after burner	850 °C	800 °C
Residence time in after burner	2 seconds	2 seconds

To meet the new standards, some crematoria have been rebuilt to larger capacity while others are closed (MILIKI, 2006). In 2020, there were 19 operating crematoria in Denmark, some with multiple furnaces. In 2010, there were 31 operating crematoria (DKL, 2021).

Crematoria that are not closed are equipped with flue gas cleaning (bag filters with activated carbon) and use of air pollution control devices. The use of air pollution control devices will however not affect the greenhouse gas emissions.

Around half of the Danish crematoria are currently connected to the district heating system and in addition, a few crematoria produce heat for use in their own buildings. The bag filter cleaning system requires that the flue gas is cooled down to 125-150 °C, and the cheapest way to do so is to use the surplus heat in the district heating system (DKL, 2009). The heat contribution from crematoria is negligible compared to the total district heat production and is not part of the Danish energy statistics. Therefore, it is not included in the Energy sector.

Activity data

Table 7.4.3 shows the time series of total number of nationally deceased persons (Statistics Denmark, 2021), number of cremations and the fraction of cremated corpses in relation to the total number of deceased (DKL, 2021). Annex 3F, Table 3F-4.2 presents data for the entire time series 1990-2020.

Table 7.4.3 Data human cremations, DKL (2021), Statistics Denmark (2021).

Year	1990	1995	2000	2005	2010	2015	2018	2019	2020
Nationally deceased	60 926	63 127	57 998	54 962	54 368	52 555	55 232	53 958	54 645
Cremations	40 991	43 847	41 651	40 758	42 050	43 238	46 340	46 341	46 910
Cremation fraction, %	67.3	69.5	71.8	74.2	77.3	82.3	83.9	84.9	85.9

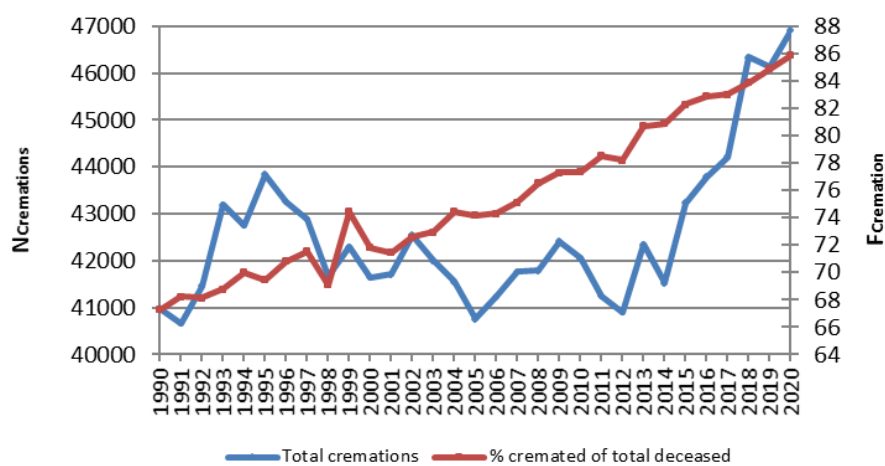

Figure 7.4.1 Visualisation of the development in cremations (DKL, 2021) where the number of cremation, $N_{cremations}$, is shown at the left Y-axis. The cremation percentage, $F_{cremations}$, shows the percentage of cremated deceased of the total number of deceased for the years 1990-2020.

Even though the total number of annual cremations is fluctuating, the cremation percentage has been steadily increasing since 1990. The average body weight is assumed to be 65 kg (EEA, 2016).

Figure 7.4.2 presents the trend of the number of deceased persons together with the activity data for human cremation. The figure shows a direct connection between the number of deceased and the activity of human cremation as the two trends are quite similar. Figure 7.4.2 also shows the effect of the increasing fraction of cremations per deceased, as the number of cremations is not decreasing along with the number of deceased.

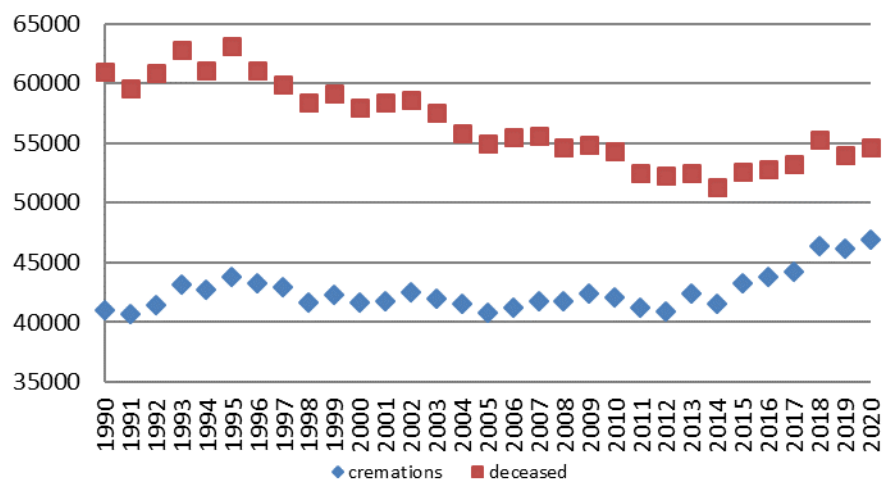

Figure 7.4.2 Trends of the activity data for cremation of human corpses and the national number of deceased persons.

Emission factors

For human cremation, emissions are calculated by multiplying the total number of human cremations by the emission factors. Since there are no continuous measurements available of the annual emission from Danish crematoria, the estimation of emissions is based on emission factors from literature.

A literature search has provided the emission factors shown in Table 7.4.4. It has not been possible to find any additional data to validate the emission factors. It is not clear from the reference, whether the emission factors includes any contribution from the fuel use. However, as the EFs are originally used in an inventory following the same reporting guidelines, it is assumed that the EFs only includes the contribution from the corpses and the casket or other storage materials.

Table 7.4.4 Emission factors for human cremation with references.

Pollutant name	Unit	Emission factor	Reference
CH ₄	g/body	11.8	Aasestad, 2008
N ₂ O	g/body	14.7	Aasestad, 2008

7.4.2 Animal cremation

The incineration of animal carcasses in animal crematoria follows much the same procedure as human cremation. Animal crematoria use similar two chambered furnaces and controlled incineration. However, animal carcasses are incinerated in special designed plastic (PE) bags rather than coffins. Emissions from animal cremation are similar to those from human cremation.

Animal cremations are performed in two ways, individually where the owner often pays for receiving the ashes in an urn or collectively, which is most often the case with animal carcasses that are left at the veterinarian.

Methodological issues

Open burning of animal carcasses is illegal in Denmark and is not occurring, and small-scale incinerators are not known to be used at Danish farms. Livestock that is diseased or in other ways unfit for consumption is disposed of through rendering plants. Incineration of livestock carcasses is illegal and

these carcasses are therefore commonly used in the production of fat and soap at Daka Bio-industries.

The only animal carcasses that are approved for cremation in Denmark are deceased pets and animals used for experimental purposes, where the incineration must take place at a specialised animal crematorium. There are four animal crematoria in Denmark; one of these is situated at a waste incineration company in northern Jutland called AVV. The specially designed cremation furnaces are at this location connected to the flue gas cleaning equipment of the municipal waste incineration plant with energy recovery and the emission from the cremations are therefore included in the annual inventory from AVV and consequently included under the energy sector in this report. Therefore, only three animal crematoria are included in this section.

Animal by-products are regulated under the EU commission regulation no. 142/2011. This states that animal crematoria must be approved by the authority and comply either with the EU directive (2000/76/EC) on waste incineration or with Regulation (EC) No. 1069/2009 (EC, 2009).

The incineration of animal carcasses is, as the incineration of human corpses, performed in special incineration chambers. All Danish animal crematoria have primary combustion chambers with temperatures around 850 °C and secondary combustion chambers with temperatures around 1100 °C. The support fuel used at the Danish facilities is natural gas.

Activity data

Activity data for animal cremation are gathered directly from the animal crematoria. There is no national statistics available on the activity from these facilities. The precision of activity data therefore depends on the information provided by the crematoria.

Table 7.4.5 lists the four Danish animal crematoria, their foundation year and provides each crematorium with an id letter.

Table 7.4.5 Animal crematoria in Denmark.

Id	Name of crematorium	Founded in
A	Dansk Dyrekremering ApS	May 2006
B	Ada's Kæledyrskrematorium ApS	Unknown, Has existed for more than 30 years
C	Kæledyrskrematoriet	2006
D	Kæledyrskrematoriet v. Modtage-station Vendsyssel I/S	-

Crematorium D is situated at the AVV municipal waste incineration site and the emissions from this site are, as previously mentioned, included in the annual emission reporting from AVV and consequently included in the energy sector in this report as waste incineration with energy recovery. Therefore, only crematoria A-C are considered in this chapter.

Table 7.4.6 lists the activity data for animal crematoria A-C. The entire dataset for 1990-2020 is available in Annex 3F, Table 3F-4.3.

Table 7.4.6 Activity data. Source: direct contact with all Danish crematoria.

	1990	1995	2000	2005	2010	2015	2018	2019	2020
Total, t	150	200	443	762	1 449	1 119	1 169	1 131	995

Crematorium B delivered exact annual activity data for the years 1998-2011 and 2015-2020. They were not certain about the founding year but believe to have existed since the early 1980es. Activity data for 1990-1997, 2012, 2013 and 2014 has therefore been estimated by expert judgement by DCE. It is not possible to extrapolate data back to 1990 because the activity, due to the steep trend line, in this case would become negative.

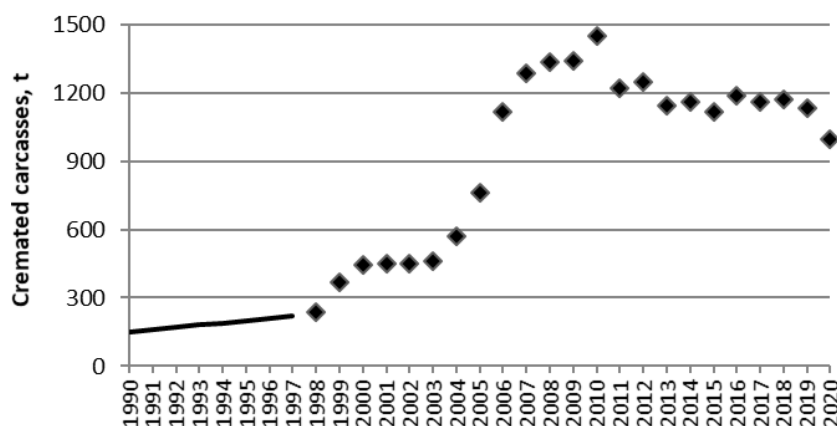

Figure 7.4.3 The amount of animal carcasses cremated (t). Data from 1998-2020 are delivered by the crematoria and is considered to be exact; these data are marked as points. Data from 1990-1997 are estimated and are shown as the thick line in the figure.

Emission factors

Concerning the incineration of animal carcasses in animal crematoria there is not much literature to be found.

Emission factors for CH₄ and N₂O are collected from the literature search on human cremation and it is assumed that humans and animals are similar in composition for this purpose. Emission factors from human cremation are recalculated to match the activity data for animal cremation. Table 7.4.7 lists the emission factors and their respective references. As stated in the description of the emission factors for human cremation, it is not clear from the reference, whether a contribution from the fuel has been included.

Table 7.4.7 Emission factors for animal cremation.

Pollutant name	Unit	Emission factor	Reference
CH ₄	g/t	182	Aasestad, 2008
N ₂ O	g/t	226	Aasestad, 2008

7.5 Wastewater treatment and discharge

The Danish wastewater treatment system is characterised by few big and advanced wastewater treatment plants (WWTPs) and many smaller WWTPs. From 1993 to 2014, the amount of wastewater treated at the most advanced technological WWTPs in Denmark has increased from 53 % to above 90 %. Improvements of the decentralised wastewater treatment systems as well as the sewer system are on-going in Denmark (DEPA, 2010b). For the part of the population, which is not connected to the collective sewer system, i.e. scattered houses, septic sludge are collected once per year or as appropriate by judgement of the local authorities (DEPA, 1999b). Municipal collection and transportation of sludge from septic tanks for treatment at the centralised WWTPs occurs at a frequency set by the local authorities and in general, septic tanks are emptied one time each year.

A presentation of methodological approach, emission factors, activity data and recalculations are presented in the following sub-chapters.

7.5.1 Source category description

This source category includes an estimation of the emission of CH₄ and N₂O from wastewater handling; i.e. wastewater collection and treatment. CH₄ is produced during anaerobic conditions and treatment processes, while N₂O may be emitted as a by-product from nitrification and denitrification processes under anaerobic as well as aerobic conditions (e.g. Adouani et al., 2010; Kampschreur et al., 2009).

Wastewater streams from households and industries are increasing mixed in the sewer system prior to further treatment at centralised WWTPs. The contribution from the industry to the influent wastewater at the centralised WWTPs has increased from zero in 1987 to around 40 % from 2006 (Table 7.5.3) with the highest influent contribution occurring at the biggest and most advanced technological WWTPs in Denmark (DNA, 2010; Thomsen, 2016).

Documentation for the fraction of the population not connected to the sewer system is still missing, and therefore the fraction of the population not connected to the collective sewer system is kept at 10 % (DEPA, 2015; Thomsen, 2016).

Regarding diffuse emissions from the sewer system, very little data are available (e.g. Lyngby-Taarbæk Kommune, 2014). It is known that centralized wastewater treatment plants are associated with increased residence times, which increases the risk of the occurrence of bottom sediments and thus biological decomposition of organic matter in the sewage system. However, the sewer system is hydraulically designed to prevent the accumulation of bottom sediments and under such conditions, temporary anaerobic processes will be dominated by fermentation and sulphate reduction, which means that the possibility of methane formation may be ignored (DANVA, 2008; DANVA, 2011; Hvitved-Jacobsen, 2001).

The indirect N₂O emissions from separate industries are included, as effluent N-data are available from the National Monitoring and Assessment Programme for the Aquatic and Terrestrial Environments (NOVANA) (DEPA, 1994, 1996b, 1997, 1998b, 1999b, 2000, 2001c, 2002b, 2003, 2004c, 2005b, 2005c and DNA, 2007, 2009, 2010, 2011, 2012, 2013, 2014, 2015, 2016, 2017, 2018, 2019, 2020, 2021). The direct N₂O from separate industries are calculated by the use of activity data on the amount of N in the effluent wastewater and data on treatment efficiency at industrial wastewater treatment plants. The methodological approach are described in Thomsen (2016) and in chapter 7.5.2.

Methane emission

Fugitive methane emissions from the municipal and private WWTPs have been divided into contributions from 1) the sewer system, primary settling tank and biological N and P removal processes, 2) from anaerobic treatment processes in closed systems with biogas recovery for energy production and 3) septic tanks. The individual contribution to the net methane emission is given in Table 7.5.1, data for the whole time series is provided in Annex 3F, Table 3F-5.1.

Table 7.5.1 Produced, recovered and emitted CH₄ from wastewater treatment, kt.

Year	1990	1995	2000	2005	2010	2015	2016	2017	2018	2019	2020
Biogas production, TJ	458	598	857	913	840	901	1057	962	997	1240	1307
CH _{4,AD,gross}	12.69	18.43	21.20	20.87	21.28	21.61	24.83	23.78	24.72	30.24	31.81
CH _{4,recovery}	12.57	18.27	20.97	20.63	21.06	21.37	24.55	23.53	24.45	29.92	31.46
CH _{4,AD,net}	0.12	0.16	0.23	0.24	0.22	0.24	0.28	0.25	0.26	0.33	0.35
CH _{4,sewer+MB}	0.22	0.25	0.27	0.27	0.28	0.29	0.28	0.30	0.30	0.29	0.29
CH _{4,st}	1.30	1.32	1.35	1.37	1.40	1.44	1.45	1.46	1.47	1.47	1.48
CH _{4,total}	1.64	1.73	1.85	1.89	1.91	1.96	2.01	2.01	2.03	2.09	2.12

Regarding the time trend, the net CH₄ emission from anaerobic treatment has increased 186 % from 1990 to 2020, while a less significant increase is observed in the CH₄ emission from the sewer system, mechanical and biological treatment is observed (33%). Lastly, the CH₄ emission from scattered houses not connected to the collective sewer system has increased with 13 % reflecting the increase in the number of people not connected to the collective sewer system. In total CH₄ emissions quantified as a sum of CH₄ emissions from anaerobic treatment processes, i.e. $CH_{4,AD,net}$, the sewer system, mechanical and biological treatment, i.e. $CH_{4,sewer+MB}$ and scattered houses, i.e. $CH_{4,st}$, has increased by 29 % from 1990 to 2020.

Nitrous oxide emission

N₂O formation and releases, both during the treatment processes at the WWTPs and from discharged effluent wastewater, are included.

The emission of N₂O from wastewater handling is calculated as the sum of contributions from wastewater treatment processes at the WWTPs (direct emissions) and from sewage effluents (indirect emissions). The emission from effluent wastewater, i.e. indirect emissions, includes separate industrial discharges, rainwater-conditioned effluents as well as effluents from scattered houses and from aquaculture.

Table 7.5.2 shows the total N₂O emission originating from treatment processes at the Danish WWTPs (direct emissions) and effluents to the Danish surface waters (indirect emissions). The full time series 1990-2020 is shown in Annex 3F, Table 3F-5.2.

Table 7.5.2 N₂O emissions from wastewater, t.

	1990	1995	2000	2005	2010	2015	2016	2017	2018	2019	2020
N ₂ O, indirect	183.8	119.1	78.6	55.3	54.7	57.3	52.0	53.4	45.1	51.2	46.2
N ₂ O, direct, separate industries	424.7	407.7	148.0	75.1	55.8	54.7	56.1	45.5	61.2	39.3	46.6
N ₂ O, direct, municipal WWTPs	193.8	294.9	355.8	426.2	361.1	402.7	385.0	404.4	399.8	391.1	400.0
N ₂ O, total	802.3	821.7	582.4	556.6	471.6	514.6	493.0	503.3	506.1	481.6	492.8

Regarding the time trend, the indirect N₂O emission has decreased 75 % N₂O from 1990 to 2020, the direct N₂O emission from separate industries has decreased by 89 %, while the direct N₂O emission from municipal wastewater treatment plants have increased by 106 %. The latter is mainly due to the fact the fraction of industrial wastewater being treated at municipal WWTPs has increased to 40% during the whole time series. In total, the N₂O emission has decreased 39 % from 1990 to 2020.

7.5.2 Methodology and data

The methodology developed for this submission for estimating emission of methane and nitrous oxide from wastewater handling follows the IPCC Guidelines (IPPC, 2006).

Monitoring data on the influent and effluent resources, i.e. N, P, biological oxygen demand (BOD) and chemical oxygen demand (COD) for the wastewater are available for all WWTPs in Denmark reported by the Danish Nature Agency, the National Focal Point for point sources. The Danish Nature Agency collects all point source data the National Monitoring and Assessment Programme for the Aquatic and Terrestrial Environments, NOVANA. Since the late eighties annually reports documenting results from the monitoring of point sources; wastewater treatment plants, industry, rainwater conditioned effluent (storm water), scattered houses, freshwater aquaculture and mariculture. The results of point source monitoring are reported in reported yearly (DEPA, 1994, 1996b, 1997, 1998b, 1999b, 2000, 2001c, 2002b, 2003b, 2004c, 2005b, 2005c and DNA, 2007, 2009, 2010, 2011, 2012, 2013, 2014, 2015, 2016, 2017, 2018, 2019, 2020, 2021).

Data on energy production from Danish wastewater treatment plant with anaerobic sludge digestion is reported in the energy statistics; data received from the Danish Energy Agency (Table 7.5.1 and Annex 3F, Table 3F-5.1). These data do not include any information on venting or flaring, which are however included in the reported gross energy production data (Tafdrup, 2014).

Data on flaring and venting have been obtained from Environmental reports (or green accounts) publish by the individual WWTPs, in some cases on a yearly basis. Data on biogas lost via venting is scarce but based on a review of plant level environmental account data reported voluntary by the WWTPs an EF value of 1.3 % of the gross energy production were applied (Table 7.5.3; Thomsen, 2016).

Country-specific data on the emission factor for direct N₂O emissions are based on monitoring data as presented in Thomsen et al., 2015 and Thomsen, 2016.

This section is divided into methodological issues related to the CH₄ and N₂O emission calculations, respectively.

Methane emissions from private and municipal WWTPs

The methane emissions from WWTP are divided into a contribution from the sewer system, primary settling tank and biological N and P removal processes. $CH_{4, sewer+MB}$, and from anaerobic treatment processes in closed systems with biogas extraction for energy production, $CH_{4,AD}$.

$$CH_{4,WWTP} = CH_{4,sewer+MB} + CH_{4,AD} \quad \text{Eq. 7.5.1}$$

The fugitive emissions from the sewer system, primary settling tank and biological N and P removal processes, $CH_{sewer+MB}$, are estimated as:

$$CH_{4,sewer+MB} = EF_{sewer+MB} \cdot TOW_{inlet}$$

↓

Eq. 7.5.2

$$CH_{4,sewer+MB} = B_o \cdot MCF_{sewer+MB} \cdot TOW_{inlet}$$

where

TOW_{inlet} equals the influent organic degradable matter measured as the chemical oxygen demand (COD) in the influent wastewater flow.

B_o is the default maximum CH_4 producing capacity, i.e. 0.25 kg CH_4 per kg COD (IPCC, 2006).

$MCF_{sewer+MB}$ is the fraction of DOC that is anaerobically converted in sewers and WWTPs. $MCF_{sewer+MB}$ equals 0.003 based on an expert judgement (Vollertsen, 2012) of a conservative estimate of the fugitive methane emission from the primary settling tanks and biological treatment processes is well below 0.1 % of influent COD, while the fugitive emission from the sewer system is judged to be negligible or zero (DANVA, 2008; DANVA, 2011).

The emission factor, $EF_{sewer+MB}$, for these three processes and systems equals 0.0008 kg CH_4 per kg COD.

The methane emission from anaerobic digestion is calculated as:

The gross methane emission potential from anaerobic processes, $CH_{4,AD,gross}$, is calculated as:

$$CH_{4,AD,gross} = f_{AD} \cdot MCF_{AD} \cdot B_o \cdot TOW_{inlet} \quad \text{Eq. 7.5.3}$$

where

f_{AD} is the fraction of the COD in the influent wastewater that are conserved in the ingestate set equal to 0.6 (Jensen et al., 2015; Thomsen et al., 2015).

MCF_{AD} , the methane correction factor, adjust the default maximum CH_4 producing capacity or theoretical methane yield to the expected conversion yield under real operating conditions and is set equal to 0.8 (IPCC, 2006).

TOW_{inlet} equals the influent organic degradable matter measured as the sum of chemical oxygen demand (COD) in the influent wastewater at WWTPs using anaerobic sludge digestion in a digester tank for the production of biogas.

B_o is the default maximum CH_4 producing capacity, i.e. 0.25 kg CH_4 per kg COD (IPCC, 2006). By dividing B_o with the density of methane, i.e. 0.72 kg CH_4/m^3 t STP (Standard Temperature and Pressure), the theoretical methane yield of 0.35 Nm^3 CH_4 per kg COD is obtained, a value which, as expected, is strongly under matched in real operating conditions (DEA, 2015).

The net methane emission from anaerobic digestion in biogas tanks are at present estimated according to equation 7.5.4:

$$CH_{4,AD,net} = EF_{AD} \cdot CH_{4,AD,recovered} \quad \text{Eq. 7.5.4}$$

where the emission factor, EF_{AD} , has been set equal to 1.3 % of the methane content in the gross energy production at national level reported by the Danish Energy Agency, i.e. 0.013 (Thomsen, 2016).

At the present stage of verification of activity data, equation 7.5.4 has been applied for estimating the net methane emission from anaerobic digestion of sludge, i.e. the net methane emission from anaerobic digestion equals the methane emissions due to venting (Thomsen, 2016).

Methane emissions from septic tanks

For the part of the population not connected to the collective sewer system, simple decentralised wastewater handling is assumed and modelled as septic tanks. Only little knowledge is available about the frequency of collection and few measurements of the methane emissions from septic tanks and the pumping and management of septage, including its transportation to a wastewater treatment facility exist (Nielsen et al., 2018). The methane emission is calculated as:

$$CH_{4,st} = B_o \cdot MCF_{ST} \cdot f_{nc} \cdot P \cdot DOC_{st} \quad \text{Eq. 7.5.5}$$

$$CH_{4,st} = EF_{st} \cdot f_{nc} \cdot P \cdot DOC_{st}$$

where

f_{nc} is the fraction of the population that is not connected to the sewer system, i.e. scattered houses, which is set equal to 10 %.

P is the population number

DOC_{st} is the per capita produced degradable organic matter (DOC) which equals 54.31 kg COD per person per year derived from the default value of 62 g BOD/person/year multiplied by the COD/BOD factor of 2.4 (IPCC, 2006).

The EF_{st} value is equal to $B_o \cdot MCF_{st}$, where the default maximum CH_4 producing capacity, B_o , equals 0.25 kg CH_4 per kg COD (IPCC, 2006) and the methane conversion factor MCF_{st} in earlier NIRs have been set equal 0.5 (IPCC, 2006) assuming that degradation for the settled DOC occurs at 100 % anaerobic conditions. The MCF_{st} value depends on the extent to which COD settles in the septic tanks.

Using the default maximum methane producing capacity, B_o , and a methane conversion factor, MCF_{st} , of 0.5 (IPCC guidelines, 2006, Table 6.3) results in an emission factor, EF_{st} , equal to 0.125 kg CH_4 /kg COD.

However, new measurement have shown that the EF value is overestimated (Nielsen et al, 2018; Vollertsen, 2018). From the submission in 2019 onwards, a country-specific $B_o \cdot MCF_{st}$ has been calculated based on the measured methane emission of 0.695 g CH_4 /PE/d (Nielsen et al., 2018), as shown in equation 7.5.6. Based on these measurements, a country-specific EF value has been derived as shown below:

$$EF_{st} = \frac{0.695 \text{ g } CH_4/PE/d}{DOC_{st}} * 10 = 0.047 \frac{\text{kg } CH_4}{\text{kg COD}} \quad \text{Eq. 7.5.6}$$

where DOC_{st} is set equal to 148.8 g COD/PE/d using the default value of 62 g BOD/person/day (Table 6.4 on page 14 in Chapter 6 of the 2206 IPCC guidelines) and the default BOD/COD conversion factor of 2.4 (page 12 in Chapter 6 of the 2006 IPCC guidelines).

The country-specific EF_{st} value is derived by applying an uncertainty factor of 10 to account for the fact that the general state of installed septic tanks are of older date and may not be functioning optimal (Vollertsen, 2018). As such, the MCF_{ST} , hence the EF value, is reduced by a factor 2.6 (from 0.125 to 0.047 kg CH₄/kg COD).

Annual activity data and emission factors used for calculation the net methane emission

Monitoring data on the influent BOD and COD are available for mixed industrial and household wastewater, which are used for calculating the total organic waste (TOW) in the influent wastewater. From 1990 to 1997, no BOD or COD data for Danish WWTPs exists. For the years 1998-2014, data on COD and BOD are available.

In the second approach, an average of BOD/COD ratios throughout the time series equal to 2.7 was applied to in place of the default value of Danish monitoring data for BOD and COD. The Danish COD/BOD ratio is on average 2.7 throughout the time series. Based on plant level data on TOW and energy production, the fraction of TOW in units of Kt COD at anaerobic WWTPs has been derived. Details on the activity data reported in Thomsen, 2016. The time series for activity data on TOW are presented in Table 7.5.3. The full time series is presented in Annex 3F, Table 3F-5.3.

Table 7.5.3 Time series for the contribution from industrial wastewater to the influent TOW at Danish wastewater treatment plants, population number, measured BOD and COD data and resulting COD/BOD ratio.

Year	1990	1995	2000	2005	2010	2015	2016	2017	2018	2019	2020
Industrial inlet, %	2.5	22.2	38.0	40.5	40.5	40.5	40.5	40.5	40.5	40.5	40.5
Population-estimate (1000)	5135	5216	5330	5411	5535	5660	5707	5749	5781	5806	5823
TOW, kt COD	295	327	365	364	372	385	378	397	398	392	391
TOW, kt BOD	97	116	149	141	145	168	169	170	171	172	173
COD/BOD ratio	3.1	2.8	2.5	2.6	2.6	2.3	2.2	2.3	2.3	2.3	2.3
COD _{influent,anaerobic} [kt]*	106	154	177	174	177	180	207	198	206	252	265

*The amount of the influent TOW at Danish WWTP using anaerobic digestion as sludge management strategy.

The TOW data, measured in units of kt COD/year, were used to estimate the fugitive methane emissions from the sewer system, primary settling tank and biological N and P removal processes according to equation 7.5.2.

For the anaerobic digestion of sludge, the Danish energy statistics were used to quantify the amount of methane lost by venting; i.e. EF_{AD} value of 0.013 (Equation 7.5.4). A detailed verification of the activity data used for justifying the national EF_{AD} value is provided in Table 7.3.5 and in Thomsen, 2016.

For scattered houses, the default IPPC BOD/COD conversion factor of 2.4 was considered most representative, as the average Danish BOD/COD ratio of 2.6 reflects the presence of industrial COD in the influent wastewater at Danish WWTPs (Table 7.5.3).

Overall methane emission time trends

The trends in the CH₄ emission from the Danish WWTPs. as summarised in Table 7.5.1, are presented graphically in Figure 7.5.1.

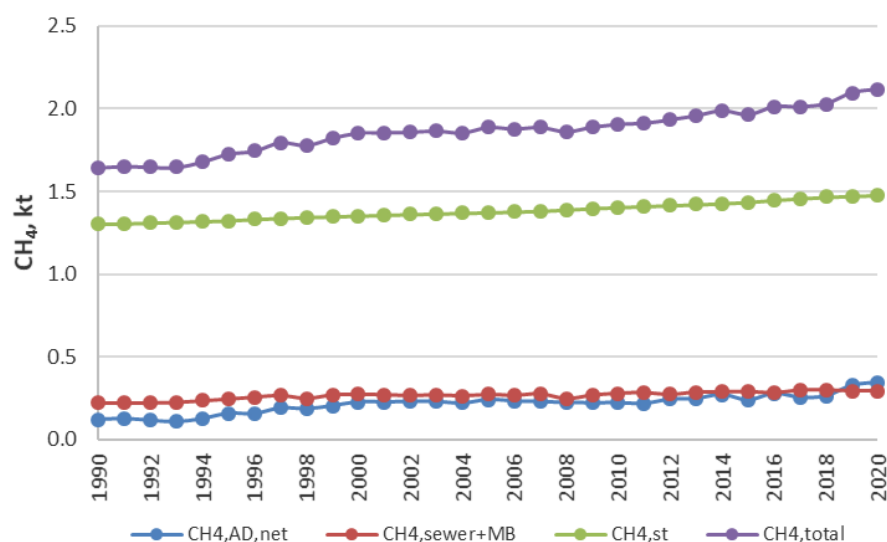

Figure 7.5.1 Time trends for net methane emission, methane emission from sewer systems, mechanical and biological treatment, from septic tanks and from anaerobic treatment processes.

The methane emission due to venting, i.e. $CH_{4,AD,net}$, has increased by a factor 2.9 from 1990 to 2020. The methane emission from the sewer system, mechanical and biological treatment, i.e. $CH_{4,sewer+MB}$, has increase by 33 % from 1990 to 2020. The methane emission from scattered houses, i.e. $CH_{4,st}$, has increased by 13 %.

The total methane emissions, i.e. $CH_{4,total}$, has increased from 1.64 kt in 1990 to 2.12 kt methane in 2020 corresponding to an increase in the total methane emissions from wastewater handling of 29 %.

N₂O emissions from WWTPs

N₂O may be generated by nitrification (aerobic processes) and denitrification (anaerobic processes) during biological treatment. Starting material in the influent may be urea, ammonia and proteins, which are converted to nitrate by nitrification. Denitrification is an anaerobic biological conversion of nitrate into dinitrogen. N₂O is an intermediate of both processes. A Danish investigation indicates that N₂O is formed during aeration steps in the sludge treatment processes as well as during anaerobic treatments, the former contributing most to the N₂O emissions during sludge treatment (Gejlsbjerg et al., 1999; Thomsen et al., 2015). A review by Kampschreur et al. (2009) documents that around 90 % of the emitted N₂O originates from activated sludge processes. Based on this review an average of two highest EF values, i.e. 0.6 % N₂O (Wicht et al., 1995) and 0.035 % (Czepiel et al., 1995), both reported in units of per cent N load in the influent wastewater, was applied to derive a national EF for the direct emission of nitrous oxide of 0.32 % or 0.0032 kg N₂O-N/kg N in the inlet wastewater. The national EF value was comparable to earlier reporting's on two WWTPs by Andersen et al., (2013). However, a newer monitoring campaign running on nine wastewater treatment plants in the period 2018 to 2020, covering a wide range variety of plants in terms of size, nitrogen loading, aeration technology, sludge treatment configuration and reject water handling showed that the Danish EF value used until the 2020 inventory submission was underestimated (DEPA, 2020c). Since the monitoring campaign is based on a wider amount of data, and its value corresponds with recent studies from the LaGas-project on the biggest WWTP in Denmark (Delre et al., 2017), the

newly documented direct N₂O emission factor of 0.0084 kg N₂O-N/kg T-N_{inlet} (DEPA, 2020c) was applied from the 2021 inventory submission.

The direct N₂O emission from wastewater treatment processes is calculated according to Equation 7.5.6:

$$E_{N_2O} = EF_{N_2O,direct} \cdot m_{N,influent} \cdot \frac{M_{N_2O}}{2 \cdot M_N} \quad \text{Eq. 7.5.6}$$

where

$EF_{N_2O,direct}$ is equal to a fraction of 0.0084 of the N load in the influent wastewater.

$m_{N,influent}$ is the annually reported N load in the Danish Water Quality Parameter Database provided in Table 7.5.4.

M_{N_2O}/M_{N_2} is the mass ratio i.e. 44/28 to convert the fraction of N emitted as nitrous oxide from total N.

The country-specific EF value of 0.0084 kg N₂O-N/kg T-N_{inlet} (DEPA, 2020c) may be expressed as $EF_{N_2O,direct} = 13.2$ g N₂O per kg N load in the influent wastewater by reducing eq. 7.5.6 to:

$$E_{N_2O} = EF_{N_2O,direct} \cdot m_{N,influent} \quad \text{Eq. 7.5.7}$$

The methodology adopted for estimating the direct N₂O emission only relies on the influent N load as activity data.

The indirect N₂O emission from WWTPs is calculated according to Equation 7.5.8:

$$E_{N_2O,WWTPeffluent} = D_{N,WWTP} \cdot EF_{N_2O,WWTPeffluent} \cdot \frac{M_{N_2O}}{2 \cdot M_N} \quad \text{Eq. 7.5.8}$$

where

$D_{N,WWTP}$ is the effluent discharged sewage nitrogen load consisting of contributions from municipal wastewater treatment plants, the separate industry, effluent from aquaculture, rainwater conditioned effluents and scattered houses not connected to the sewage system (cf. Table 7.5.4).

$EF_{N_2O,WWTPeffluent}$ is the IPCC default emission factor of 0.005 kg N₂O-N per kg sewage-N produced (IPPC, 2006).

M_{N_2O}/M_{N_2} is the mass ratio i.e. 44/28 to convert the fraction of discharged N emitted as nitrous oxide from total N.

Annual activity data and emission factors for calculating the nitrous oxide emission

Data on the N content in the influent and effluent wastewater flows are provided in Table 7.5.4. The effluent data provided in the table constitute a sum of the N content in effluent wastewater from municipal wastewater treatment plants, the separate industry, effluent from aquaculture, rainwater

conditioned effluents and scattered houses. For the entire time series, 1990-2020 cf. Annex 3F, Table 3F-5.4.

Table 7.5.4 Nitrogen content in the influent and effluent wastewater, t

	1990	1995	2000	2005	2010	2015	2016	2017	2018	2019	2020
Influent, Municipal WWTPs ¹	14679	22340	26952	32288	27357	30509	29166	30636	30288	29629	30301
Influent, Industrial WWTPs ¹	32175	30888	11213	5688	4225	4141	4250	3450	4636	2978	3533
Effluent wastewater from WWTPs	16884	8938	4653	3831	4025	3705	3400	3482	3127	3654	3245
Effluent wastewater, total ²	23396	15152	10005	7038	6960	7288	6612	6798	5745	6520	5879

¹Data on the influent wastewater N load from municipal WWTPs are available from the Danish Water Quality Parameter Database held by the Danish Nature Agency.

²Effluent wastewater, total includes discharges from the separate industry, rainwater conditioned effluent, scattered houses, aquaculture farming and effluents from WWTPs (DEPA, 1994, 1996b, 1997, 1998b, 1999b, 2000, 2001c, 2002b, 2003b, 2004c, 2005b, 2005c, 2018, 2019, 2020 and DNA 2007, 2010, 2011, 2012, 2013, 2014, 2015, 2016, 2017, 2018, 2019, 2020, 2021).

The reduction of N in the effluent wastewater from Danish WWTPs compared to in influent wastewater has increased from a reduction efficiency of 30 % in 1990 to a reduction efficiency of 88 % in 2016 (DNA, 2018). The significant reduction in the effluent wastewater content of nitrogen has been a driver for the increasing direct N₂O emission from WWTPs. However, emerging wastewater treatment technologies may cause an increased N capture in the sludge (Kristensen & Jørgensen, 2008; Thomsen et al., 2015).

The influent N load at industrial WWTPs not collected to the collective sewer systems were estimated from reported N in the effluents from separate industries and knowledge of an N reduction efficiency of 92 % for industrial WWTPs (Thomsen, 2016).

Overall nitrous oxide emission trends

The trends in the direct N₂O emission from WWTPs, the indirect emission from wastewater effluent and the total nitrous oxide emissions, as summarised in Table 7.5.5, are presented graphically in Figure 7.5.2.

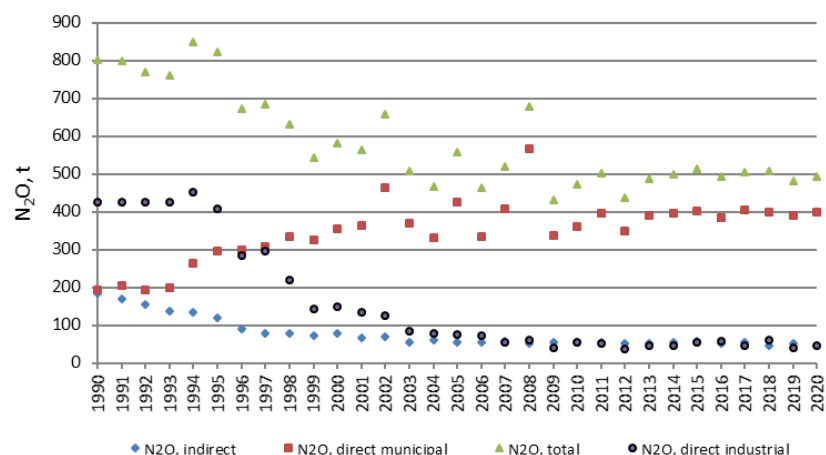

Figure 7.5.2 Time trends for the direct and indirect emission of N₂O (from wastewater effluents) and total N₂O emission.

The annual fluctuations may be caused by several factors, e.g. climatic condition such as variations in precipitation and as a result varying contributions to the influent N and varying characteristics of especially the industrial contributions to the influent. Furthermore, infiltration of groundwater, as well as exfiltration of overload rainwater and wastewater ((DEPA, 1994, 1996b, 1997, 1998b, 1999b, 2000, 2001c, 2002b, 2003b, 2004c, 2005b, 2005c and DNA, 2007, 2009, 2010, 2011, 2012, 2013, 2014, 2015, 2016, 2017, 2018, 2019,

2020, Vollertsen et al., 2002), may contribute to the “noise” or fluctuation in the trend of the calculated N₂O emission.

The total N₂O emission shows a decreasing trend from 802 tonnes in 1990 to 493 tonnes in 2020. Comparing 2020 with the base year 1990, a decrease of 39 % is observed. This trend reflects the sum of direct N₂O emissions from municipal and industrial WWTPs and the sum of indirect N₂O emissions.

The direct N₂O emissions from municipal WWTPs are increasing from 194 tonnes in 1990 to 400 tonnes N₂O in 2020 (106 %), while the direct N₂O emissions from industrial WWTPs are decreasing from 425 tonnes in 1990 to 47 tonnes in 2020 (-89 %). The opposite trends for direct N₂O emissions from industrial WWTPs is partly explained by an increase in the number of industrial WWTPs connected to the collective sewer system as reflected by the increased per cent contribution from industries to the influent wastewater at municipal WWTPs (Table 7.5.3 and Annex 3F, Table 3F-5.4). In sum a decrease in the direct N₂O emissions of 28% is observed in 2020 compared to 1990.

The decrease in the emission from effluent wastewater is due to the technical upgrade and centralisation of the Danish WWTPs following the adoption of the Action Plan on the Aquatic Environment in 1987. The indirect emission from wastewater effluent has decreased from 184 tonnes N₂O in 1990 to 46 tonnes N₂O in 2020 corresponding to a reduction of 75 %.

The indirect emission is the major contributor to the emission of nitrous oxide in the period 1990-1995. From 1996 and forward, the direct N₂O emission is the major contributor to the total N₂O emission. Overall, a net reduction of 39 % is observed for the total N₂O emission from wastewater handling in 2020 compared to 1990.

7.6 Other

The *CRF category 5.E, Other* is comprised by the subcategory accidental fires grouped into accidental building and vehicle fires as presented in sub-chapter 7.6.1 and 7.6.2. Greenhouse gasses that are estimated from these processes are CH₄ and CO₂ as presented in Table 7.6.1. No emission factors are available for N₂O, wherefore N₂O is reported as Not Estimated. The full time series for emissions related to composting are shown in Annex 3F-6, Table 3F-6.1.

Table 7.6.1 Overall emission of greenhouse gasses from accidental fires, 1990-2020.

	1990	1995	2000	2005	2010	2015	2018	2019	2020	
CO ₂ emission from										
Accidental building fires	kt	89.7	103.0	90.5	87.3	92.3	100.9	110.5	103.0	101.6
- of which non-biogenic	kt	15.8	18.1	15.9	15.3	16.1	16.5	18.2	16.7	16.6
Accidental vehicle fires	kt	6.0	6.2	6.3	6.2	6.9	5.1	6.3	6.3	6.3
Total. non-biogenic	kt	21.8	24.3	22.2	21.5	23.0	21.6	24.5	23.0	22.9
CH ₄ emission from										
Accidental building fires	t	96.4	110.7	97.2	93.7	100.1	98.8	109.4	99.5	99.7
Accidental vehicle fires	t	12.5	12.9	13.0	13.0	14.4	10.7	13.0	13.1	13.2
Total	t	108.9	123.6	110.2	106.7	114.5	109.4	122.4	112.6	112.9
5.E. Other										
CO ₂ -equivalents	kt	24.5	27.4	25.0	24.2	25.9	24.3	27.6	25.8	25.7

7.6.1 Accidental building fires

Emissions estimated from building fires are CO₂ and CH₄.

Methodological issues

Emissions from building fires are calculated by multiplying the number of building fires with selected emission factors. Six types of buildings are distinguished with different emission factors: detached house, undetached houses, apartment buildings, industrial buildings, additional buildings and containers.

Activity data

In January 2005, it became mandatory for the local authorities to register every rescue assignment in the online data registration- and reporting system called ODIN (www.odin.dk). ODIN is developed and run by the Danish Emergency Management Agency (DEMA, 2007).

Activity data for accidental building fires are given by ODIN (DEMA, 2021). Fires are classified in four categories: full, large, medium and small. The emission factors comply for full-scale fires and the activity data are therefore recalculated as a full-scale equivalent where it is assumed that a full, large, medium and a small scale fire leads to 100 %, 75 %, 30 % and 5 % of a full-scale fire, respectively.

In practice, a full-scale fire is defined as a fire where more than three fire hoses were needed for extinguishing the fire. A full-scale fire is considered as a complete burnout. A large fire is in this context defined as a fire that involves the use of two or three fire hoses for fire extinguishing and is assumed to typically involve the majority of a house, an apartment, or at least part of an industrial complex. A medium size fire is in this context defined as a fire involving the use of only one fire hose for firefighting and will typically involve a part of a single room in an apartment or house. A small size fire is in this context, defined as a fire that was extinguished before the arrival of the fire service, extinguished by small tools or a chimney fire.

The total number of registered fires is known for the years 1989-2020. For the years 2007-2020, the total number of registered building fires is known with a very high degree of detail based on information given in the yearly statistic reports (DEMA, 2021). For container fires numbers are registered for the years 2008-2016 (DEMA, 2017).

Table 7.6.2 shows the occurrence of all types of fires (registered for 1990-2020) and the occurrence of building fires (2007-2019) registered at DEMA. In 2007-2011, the average per cent of building fires, in relation to all fires, was 40 %. The total numbers of building fires 1990-2006 are calculated using this percentage. The full time series is presented in Annex 3F-6, Table 3F-6.2.

Table 7.6.2 Occurrence of all fires and building fires.

	1990	1995	2000	2005	2010	2015	2018	2019	2020
All fires	17 025	19 543	17 174	16 551	16 802	12 777	15 132	12 670	12 538
Building fires	6 832	7 842	6 891	6 641	7 094	6 245	7 193	6 436	6 534

The building fires that occurred in the years 2007-2020 are subcategorised into five building types; detached houses, undetached houses, apartment buildings, industrial buildings and additional buildings and in sizes. The

average distribution of subcategories and sizes for 2007-2011 are used to estimate the distribution of building fires in 1990-2006. These are shown in Table 7.6.3a.

Table 7.6.3a Average of registered occurrence of building fires, 2007-2011, %. (DEMA, 2021).

Type	Size		
Detached	41	Full	8
Undetached	19	Large	21
Apartment	25	Medium	40
Industry	14	Small	31
Additional	1		

For 2008-2016 the number and sizes of container fires is known. For the years 1980-2007 the number of container fires are based on the average share of all fires for 2008-2011 and for the years 2017-2020 the number is based on the average share of all fires for 2012-2016. In Table 7.6.3b are shown the average share and sizes of container fires for 2008-2011 and 2012-2016.

Table 7.6.3b Average of registered occurrence of container fires, 2008-2011 and 2012-2016, %. (DEMA, 2017).

	Average 2008-2011, %	Average 2012-2016, %
Share of all fires	11.1	8.8
Size:		
Full	0	0
Large	8	11
Medium	84	77
Small	8	12

By applying the damage rates of 100 %, 75 %, 30 % and 5 % corresponding to the damage sizes of full, large, medium and small, a full-scale equivalent can be determined. Table 7.6.4 shows the calculated full-scale equivalents (FSE). The whole time series is shown in Annex 3F, Table 3F-6.3.

Table 7.6.4 Accidental building fires full-scale equivalent activity data.

	1990	1995	2000	2005	2010	2015	2018	2019	2020
Detached house fires	1065	1223	1075	1036	1185	920	1019	907	945
Undetached house fires	480	551	484	467	447	398	286	226	242
Apartment building fires	726	833	732	706	726	635	1055	885	899
Industry building fire	409	470	413	398	408	662	699	702	660
Additional building fires	35	40	35	34	25	14	36	36	37
Container fires	593	681	598	577	513	331	426	356	353

Emission factors

For building fires, emissions are calculated by multiplying the number of full-scale equivalent fires with the emission factors. The emission factors are produced from different measurements and assumptions from literature and expert judgements. When possible, emission factors are chosen that represent conditions that are comparable to Denmark. By comparable is meant countries that have similar building traditions, with respect to the materials used in building structure and interior.

In the process of selecting the best available emission factors for the calculation of the emissions from Danish accidental building fires, a range of different sources has been studied. Unfortunately, it is difficult to perform an interrelated comparison of the different sources because they all establish emission factors on different assumptions and many of these assumptions are not fully accounted for.

Table 7.6.5 lists the emission factors that were chosen as the best reliable and their respective references.

Table 7.6.5 Average emission factors for building fires, per FSE fire. Used for all years.

Compound	Unit /fire	Detached house	Undetached house	Apartment building	Industrial building	Additional building	Container	Reference
CO ₂ - total	t	31.3	25.7	14.9	78.1	3.9	1.8	Blomqvist et al., 2002
CO ₂ - biogenic	t	25.5	21.0	12.1	67.6	3.2	0.2	Blomqvist et al., 2002
CO ₂ - non-biogenic	t	5.8	4.8	2.8	10.5	0.7	1.7	Blomqvist et al., 2002
CH ₄	kg	41.5	34.1	19.7	52.0	2.1	0.3*	NAEI, 2009

*Container fires have a different source of CH₄ emission factor than the other five categories. Blomqvist et al. 2002.

Emission factors for detached, undetached and apartment fires depend on the average floor space in 1990 to 2014 (cf. Table 7.6.6). The average emission factors is used for all years. Industrial, additional and container fires on the other hand are assumed to have a constant size/volume throughout the time series. Emission factors for detached, undetached and apartment fires for 1990-2014 are shown in Annex 3F, Table 3F-6.4a-c.

Emission factors from Aasestad (2008) are already specified for four of the six building types, detached houses, undetached houses, apartment buildings and industrial buildings (Aasestad. 2008) and all other sources considered were altered to match the six building types. This alternation was performed simply by adjusting the average floor space for each of the building types respectively, whereas factors like loss rate and mass of combustible contents per area are not altered.

The average floor space in Danish buildings is stated in Table 7.6.6. The data are collected from Statistics Denmark and takes into account possible multiple building floors but not attics and basements. For the whole time series see Annex 3F, Table 3F-6.5. The average floor space in industrial buildings, schools etc. is estimated to 500 square meters for all years and the average floor space for additional buildings, sheds etc. is estimated to 20 square meters for all years.

Table 7.6.6 The average floor space in Danish buildings (square metre).

	1990	1995	2000	2010	2011	2012	2013	2014
Detached houses	156	155	156	163	164	165	165	165
Undetached houses	129	129	131	134	132	134	133	133
Apartment buildings	75	75	75	77	78	78	78	78

Some emission factors are delivered in mass emission per mass burned. In order to connect these emission factors to the activity data, the total combustible building masses are estimated using the data from Table 7.6.7.

Table 7.6.7 Building mass per building type.

	Unit	Detached house	Undetached house	Apartment building	Industry building	Additional building	Container
Average floor area*	m ²	167	132	78	500	20	-
Building mass per floor area	kg per m ²	40	40	35	30	30	-
Total building mass	t per fire	6.7	5.4	2.7	15.0	0.6	1

* 2014 numbers.

Emission factors for container fires cannot be calculated based on an average floor space but on an average mass. The average mass of a container is set to 1 t and covers all types of containers, from small residential garbage containers to large shipping containers and waste/goods in storage piles.

For more information on the emission factors, please refer to Hjelgaard (2013).

7.6.2 Accidental vehicle fires

Emissions estimated from vehicle fires are CO₂ and CH₄.

Methodological issues

Emissions from vehicle fires are calculated by multiplying the mass of vehicle fires with selected emission factors. Emission factors are not available for different vehicle types, whereas it is assumed that all the different vehicle types leads to similar emissions. The activity data are calculated as an annual combusted mass by multiplying the number of different full scale vehicle fires with the Danish registered average weight of the given vehicle type.

Activity data

DEMA (2017) provides very detailed data for 2008-2016 for passenger cars and heavy duty vehicles. For buses, light duty vehicles (vans and motor homes), motorcycles/mopeds, other transport, caravans, trains, boats, airplanes, bicycles, tractors, combine harvesters and machines detailed data are available for 2008-2012. The remaining years are for all vehicle categories estimated by using surrogate data.

Table 7.6.8 shows the occurrence of fires in general and vehicle fires registered at DEMA. Between 2008 and 2012, the average per cent of vehicle fires, in relation to all fires, was 20 %. The total numbers of vehicle fires in 1990-2007 and 2013-2020 are calculated using this percentage. The full time series is presented in Annex 3F, Table 3F-6.6a-c.

Table 7.6.8 Occurrence of all fires* and vehicle fires**.

	1990	1995	2000	2005	2010	2015	2018	2019	2020
All fires	17 025	19 543	17 174	16 551	16 802	12 777	15 132	12 670	12 538
Vehicle fires	3 428	3 936	3 458	3 333	3 454	2 573	3 047	2 551	2 525

*(DEMA, 2021).

** (DEMA, 2017).

There are fourteen different vehicle categories. The activity data are categorised in passenger cars (lighter than 3500 kg), buses, light duty vehicles (vans and motor homes), heavy duty vehicles (trucks and tankers), motorcycles/mopeds, other transport, caravans, trains, boats, airplanes, bicycles, tractors, combine harvesters and machines.

In the same manner as accidental building fires, the 2008-2016 data from DEMA can be divided in four categories according to damage size. It is assumed that a full-scale fire is a complete burnout of the given vehicle, and that a large, medium and small-scale fire corresponds to 75 %, 30 % and 5 % of a full-scale fire respectively. The total number of full-scale equivalent (FSE) fires can be calculated for passenger cars and heavy duty vehicles for 2008-2016 and other vehicle categories for 2008-2012.

The total number of registered vehicles is known from Jensen et al. (2013) and Statistics Denmark (2021). By assuming that the share of vehicle fires in relation to the total number of registered vehicles, of every category respectively, can be counted as constant, the number of vehicle fires is estimated for the years 1980-2007 and 2017-2020 for passenger cars and heavy duty and 2013-2020 other vehicles.

Table 7.6.9 states the total number of national registered vehicles and the number of full-scale equivalent vehicle fires. The whole time series 1990-2020 is shown in Annex 3F, Table 3F-6.6a-c.

Table 7.6.9 Number of nationally registered vehicles and full-scale equivalent vehicle fires.

	Passenger Cars		Buses		Light Duty Vehicles		Heavy Duty Vehicles		
	Registered	FSE fires	Registered	FSE fires	Registered	FSE fires	Registered	FSE fires	
1990	1 590 345	437	8 109	10	247 563	21	45 678	55	
1995	1 675 432	460	14 371	18	286 049	24	48 085	58	
2000	1 853 403	509	15 051	19	335 670	28	50 227	61	
2005	1 964 057	540	15 132	19	421 019	35	49 311	59	
2010	2 147 178	726	14 781	23	447 722	38	45 632	60	
2015	2 392 282	454	12 438	16	395 397	33	41 369	38	
2018	2 596 322	713	11 817	15	389 161	32	42 606	51	
2019	2 653 640	729	11 557	15	379 871	31	42 445	51	
2020	2 725 313	749	10 973	14	376 128	31	42 131	51	
<i>Continued</i>									
	Motorcycles/Mopeds		Caravans		Train		Ship		
	Registered	FSE fires	Registered	FSE fires	Registered	FSE fires	Registered	FSE fires	
1990	164 111	55	86 257	22	7 156	8	2 324	25	
1995	166 137	55	95 831	25	6 854	7	1 911	20	
2000	233 711	78	106 935	28	4 907	5	1 759	19	
2005	274 258	91	121 350	32	3 195	3	1 792	19	
2010	304 717	83	142 354	37	2 740	2	1 773	16	
2015	286 621	95	139 654	36	3 642	4	1 742	19	
2018	279 534	93	131 257	34	3 063	3	1 712	18	
2019	261 536	87	127 705	33	3 179	3	1 721	18	
2020	263 041	87	124 399	32	3 234	3	1 727	18	
<i>Continued</i>									
	Airplane		Tractor		Combined Harvester		Bicycle	Other transport Machine	
	Registered	FSE fires	Registered	FSE fires	Registered	FSE fires	FSE fires	FSE fires	FSE fires
1990	1 055	1	162 760	108	35 118	48			
1995	1 058	1	151 233	100	29 291	40			
2000	1 070	1	123 432	82	24 128	35			
2005	1 073	1	105 208	70	21 436	32			
2010	1 155	1	95 374	77	16 451	21	4	58	94
2015	1 064	1	89 398	59	12 467	18			
2018	1 014	1	85 237	56	10 973	17			
2019	1 008	1	82 716	55	10 475	16			
2020	1 007	1	80 636	53	9 977	48			

The average weights of a passenger car, bus, light commercial vehicle, truck and motorcycle/moped are known for every year back to 1993 (Statistics Denmark, 2021). The corresponding weights from 1990 to 1992 and the average weight of the units from the remaining categories are estimated by an expert judgment (see Table 7.6.10 and Annex 3F, Table 3F-6.7).

Table 7.6.10 Average weight of different vehicle categories, kg.

Year	Cars	Buses	Vans	Trucks	Motorcycles/Mopeds
1990	850	10.000	2.000	15.000	87
1995	923	8.938	2.338	14.855	97
2000	999	9.062	2.479	15.041	103
2005	1.068	9.171	2.524	14.598	116
2010	1.144	9.160	2.517	13.902	133
2015	1.158	9.698	2.502	16.303	143
2018	1.164	9.814	2.522	16.504	150
2019	1.171	9.920	2.539	16.646	156
2020	1 178	9 973	2 558	16 773	158

It is assumed that the average weight of a boat equals that of a bus. That tractors and vans weigh the same and that trains, airplanes and combine harvesters have the same average weight as trucks.

Bicycles, machines and other transport can only be calculated for the years 2007-2012 due to the lack of surrogate data (number of nationally registered vehicles). The average weight of a bicycle, caravan, machine and other transport is estimated as 12 kg, 90 % of a car, 50 % of a car and 40 % of a car respectively.

By multiplying the number of full-scale fires with the average weight of the vehicles respectively, the total amount of combusted vehicle mass can be calculated. The result is shown in Table 7.6.11 and in Annex 3F, Table 3F-6.8.

Table 7.6.11 Burnt mass of different vehicle categories, tonnes.

Vehicle category	1990	1995	2000	2005	2010	2015	2018	2019	2020
Passenger cars	371	425	509	577	830	526	830	854	882
Buses	102	161	171	174	207	152	146	144	138
Light duty vehicles	41	55	69	88	96	82	81	80	80
Heavy duty vehicles	825	860	910	867	828	621	847	851	851
Motorcycle. moped	5	5	8	11	11	14	14	14	14
Other transport	0	0	0	0	33	0	0	0	0
Caravan	29	35	42	51	63	63	60	58	57
Train	113	107	78	49	28	63	53	56	57
Ship	247	182	170	175	147	180	179	182	183
Airplane	9	9	9	9	8	10	10	10	10
Bicycle	0	0	0	0	0	0	0	0	0
Tractor	216	234	203	176	194	148	142	139	137
Combine harvester	550	495	438	416	398	273	248	239	230
Machine	0	0	0	0	43	0	0	0	0
Total	2 509	2 570	2 606	2 592	2 885	2 131	2 610	2 626	2 639

Emission factors

In the process of selecting the most reliable emission factors for the calculation of the emissions from Danish vehicle fires, a range of different sources have been studied. Unfortunately, it is difficult to make an interrelated comparison of the different sources because they all establish emission factors on different assumptions and many of these assumptions are not fully accounted for. Table 7.6.12 lists the accepted emission factors and their respective references.

Table 7.6.12 Emission factors for vehicle fires, per tonnes.

	Unit	Emission factor	Source
CO ₂	t	2.4	Lönnermark et al., 2006
CH ₄	kg	5	NAEI. 2009
N ₂ O	-	NAV	-

NAV = not available

7.7 Uncertainties and time series consistency

The uncertainty models follow the methodology in the IPCC Guidelines (IPCC, 2006). Tier 1 is based on the simplified uncertainty analysis.

7.7.1 Input data

Solid Waste Disposal

The waste amounts for solid waste disposal are registered in a national database held by the Danish EPA and assessed to be of high quality resulting in the adoption of an uncertainty for reported waste amounts of 10 %.

Input parameter uncertainties for SWDS considered in the Tier 1 uncertainty analysis are based on the IPCC (IPCC 2006, Table 3.5) default values and provided in Table 7.7.1.

Table 7.7.1 Tier 1 input parameter uncertainty, %.

Parameter	Parameter ID	Uncertainty %
The Waste amount sent to SWDS	<i>W</i>	10
Degradable Organic Carbon	<i>DOC_i</i>	20
Fraction of DOC dissimilated	<i>DOC_f</i>	20
Methane Correction Factor	<i>MCF</i>	10
Fraction of CH ₄ in landfill gas		5
Methane Generation Rate Constant	<i>k</i>	100

The waste amounts for solid waste disposal on land are registered in a national database held by the Danish EPA and assessed to be of high quality resulting in the adoption of an uncertainty for reported waste amounts of 10 % (IPCC, 2006, Table 3.4).

Based on the uncertain range provided in Table 3.4, a simple standard deviation assuming normal probability distribution of the half-live times was calculated. The standard deviation of $t_{1/2}$ was transformed into k-values using eq. 7.2.3, resulting in an uncertainty range for the methane generation constants, *k*, of -71 % to +166 %. For the Tier 1 uncertainty calculation the uncertainty of *k* were kept at 100 %. For the remaining parameters, default uncertainties are used. The uncertainty on the implied emission factor, U_{ief} , is based on uncertainty estimates in Table 7.7.1 and is approximated with IPCC (2006) Equation 3.1 equals

$$U_{ief} \% = \text{SQRT}(20^2+20^2+10^2+5^2+100^2) = 104.5 \%$$

These uncertainties give the combined Tier 1 uncertainty on the emission from SWDS of: $\text{SQRT}(10^2+104.5^2) = 105 \%$.

In addition, the average and standard deviation of the half-life times and DOC values and remaining input parameters in Table 7.7.2 (except for the deposited amounts of waste) were derived from the 2006 IPCC guidelines

(Chapter 3, Table 3.4; Chapter 2, Table 2.4) assuming a normal distribution. A Monte Carlo calculation based on random selected values for each of the input parameters within defined 95 % confidence interval uncertainty ranges were run 1000 times returning resulting IEF and net CH₄ emission values for 1990 and 2017 (Nielsen et al, 2019). The resulting uncertainty of the IEF is 24 % in 1990 and 26 % in 2017 indicating that the tier 1 uncertainty of IEF is rather conservative.

Biological treatment of Solid waste - Composting

Table 7.7.2 lists the 95 % confidence interval uncertainties for activity data and emission factors used in this inventory and at the present level of available information. The uncertainties are assumed valid for all years 1990-2020.

Table 7.7.2 Estimated uncertainty rates for activity data and emission factors, %.

95 % confidence interval uncertainties	CO ₂	CH ₄	N ₂ O
5.B.1 Composting			
Activity data	-	20	20
Emission factor	-	100	100
5.B.2 Biogas production			
Activity data		5	
Emission factor		20	

Waste Incineration

The uncertainty of the number of human cremations is miniscule, however for the purpose of uncertainty calculation it has been set to 1 %. Table 7.7.3 lists the 95 % confidence interval uncertainties for activity data and emission factors used in this inventory and at the present level of available information.

Table 7.7.3 Estimated uncertainty rates for activity data and emission factors, %.

95 % confidence interval uncertainties	CO ₂	CH ₄	N ₂ O
Human cremation			
Activity data	-	1	1
Emission factor	-	150	150
Animal cremation			
Activity data	-	40	40
Emission factor	-	150	150

Wastewater Handling

The uncertainty levels used in the Tier 1 models are shown in Table 7.7.4.

Table 7.7.4 Estimated uncertainty rates for activity data and emission factors, %.

95 % confidence interval uncertainties	CH ₄ ,	N ₂ O
5.D.1 Domestic wastewater		
Activity	30	30
Emission factor	50	50
5.D.2 Industrial wastewater		
Activity	IE*	30
Emission factor	IE*	50

*Industrial effluent wastewater is send to the collective sewer system for treatment at municipal wastewater treatment plants, where anaerobic treatment at biogas plants take place.

Default IPCC values are assumed to be given at 95 % confidence level. Uncertainties have been derived from IPCC default values and uncertainties in country-specific parameters, respectively.

Other

The uncertainty of the total number of accidental fires is very small, but the division into building and transportation types and also the calculation of full scale equivalents will lead to some uncertainty, partly caused by the category “other”. The uncertainty for both building and vehicle activity data is therefore set to 10 % for all years. The uncertainty is however lowest for the most recent years (2008-2020) (Authors expert judgement).

Table 7.7.5 lists the 95 % confidence interval uncertainties for activity data and emission factors used in this inventory and at the present level of available information. The uncertainties are assumed valid for all years 1990-2020.

Table 7.7.5 Estimated uncertainty rates for activity data and emission factors, %.

95 % confidence interval uncertainties	CO ₂	CH ₄	N ₂ O
Accidental building fires			
Activity data	10	10	-
Emission factor	300	500	-
Accidental vehicle fires			
Activity data	10	10	-
Emission factor	500	700	-

7.7.2 Tier 1 uncertainty results

The Tier 1 uncertainty estimates for the waste sector are calculated from 95 % confidence interval uncertainties, results are shown in Table 7.7.6.

The overall uncertainty interval for greenhouse gases (GHG) is estimated to be ± 49 % and the decreasing trend in GHG emission, calculated as the per cent change in GHG emissions in 2020 compared to 1990, is $36 \text{ \%} \pm 26 \text{ \%}$ -point.

Table 7.7.6 National Tier 1 uncertainty estimates for the waste sector.

Pollutant	National emission, 2020, kt CO ₂ eqv.	Total emission uncertainty, %	Trend* 1990-2020, %	Trend uncertainty, %
GHG**	1210	± 49	-36	± 26
CO ₂	23	± 300	5	± 15
CH ₄	967	± 59	-40	± 26
N ₂ O	220	± 49	-16	± 36

*Per cent change in emission in 2020 with respect to the base year 1990.

**GHG emissions are calculated in units of CO₂ equivalents.

7.7.3 Time series consistency and completeness

Solid Waste Disposal

Registration of the amount of waste has been carried out since the beginning of the 1990s in order to measure the effects of action plans. Therefore, the activity data are considered to be consistent through the time series to make the activity data input to the FOD model reliable.

The consistency of the emissions and the implied emission factors is a result of the same methodology and the same model used for the whole time series. The parameters in the FOD model are the same for the whole time series. The use of a model of this type is recommended in IPCC (2006).

As regards completeness, waste amounts for the whole time series, i.e. 1940-2019, have been allocated according to 18 waste types as described in Chapter 7.2.1. Corresponding annual fractional distributions of the total amount of deposited waste according to type, respecting mass conservation, is presented in units of mass fractions in Table 7.2.4 (for the whole time series the reader is referred to Annex 3F, Table 3F-2.5). The composition of these waste types is, according to Danish data used to estimate DOC values for the waste types (refer IPCC 2006, Chapter 2 on Waste data). Plant level data and modelling is in progress as part of the national bio cover action plan (Executive Order No. 752 of 21/06/2016).

Biological treatment of solid waste

For compost production, activity data are not consistent as data are only available for 1995-2009. Data for 1990-1994 and 2010-2020 along with data for home composting are estimated through linear regression and with surrogate data respectively. Emission factors and calculation method are consistent throughout the time series. For 2010-2020, improved quality of the composting data has been achieved through detailed data on the waste type garden and park waste, sludge and organic waste (Nissen, 2017a).

Emissions from compost production are believed to be complete; calculations include composting at all nationally registered sites and best available estimated data for home composting.

Waste Incineration

Activity data for human cremation is considered to be consistent, as these data have been collected by DKL throughout the time series. Activity data for animal cremation on the other hand is not fully consistent. Data for 1998-2020 are gathered directly from the crematoria and data for 1990-1997 are estimated by the author's expert judgement, no surrogate data or data regression is possible.

Emission factors and calculation method are consistent throughout the time series for both human and animal cremation.

Cremation of both corpses and carcasses is considered to be complete. Open burning of carcasses is illegal and therefore not occurring in Denmark, and small-scale incinerators are not known to be used at Danish farms.

Wastewater Handling

Consistency and completeness have been improved by integrating plant level data from the Danish Energy Statistics with plant level COD data from the Danish monitoring program and plant level environmental reports (Thomsen, 2016).

Data regarding industrial on-site wastewater treatment processes have been achieved and included. Activity data for the whole time series 1990-2019 are provided in Annex 3F, 3F-5.4.

Waste Other

For accidental fires, DEMA provides detailed data for 2007-2020 and the total number of nationally registered fires for 1990-2019 (DEMA, 2020). Activity data for accidental fires are there for believed to be consistent. Both emission factors and calculation method are also consistent throughout the time series.

Emissions from accidental fires are believed to be complete. Field burning of agricultural residue is included in Chapter 5 Agriculture.

7.8 QA/QC and verification

In general terms, for this part of the inventory, the Data Storage (DS) Level 1, 2 and 4 and the Data Processing (DP) Level 1 can be described as follows.

7.8.1 Data Storage Level 1

The external data level refers to the placement of the original input data used for estimating annual activity and emission factors in the waste sector. Data references in terms of reports and databases used for deriving input for the emission calculations. Reports and a list of links to external data sources are stored in a common data storage system including all sectors of the annual NIR.

Table 7.8.1 Overview of annually stored external data sources at DS level1.

http. file or folder name	Description	AD or EF	Reference	Contact	Data agreement/ Comment
DCE data-exchange folder: O:\Tech_ENVS-Luft-Emi\Inventory\2019\6_Waste\Level_1b_Processing	Inventory data storage system	AD and EF	DCE		
Report series published by the Danish Nature Agency (DNA) and available from the Danish Nature Agency (DNA) www.nst.dk and the Danish Environmental Protection Agency www.mst.dk			Report series: "Point sources" (2006-2017)	MST Østjylland Lisbeth Nielsen (linie@mst.dk)	Public available reports
Danish Water Quality parameter Database	Annually reported wastewater characteristics at plant level which includes all years 1990-2015	AD	www.miljoportal.dk	MST Østjylland Lisbeth Nielsen (linie@mst.dk)	Authorised access
DCE data-exchange folder: O:\Tech_ENVS-Luft-Emi\Inventory\2019\6_Waste\Level_1a_Storage	Raw data extracts from the Danish Waste Reporting System	AD	The Danish Environmental Protection Agency. Database on all registered Danish waste. Available at: www.ads.mst.dk	Ellen Lindholt Nissen Unit of Circular Economy and Waste (elnli@mst.dk)	The amounts are registered due to statutory requirements
DCE data-exchange folder: O:\Tech_ENVS-Luft-Emi\Energy\2019	Basic data DS1 Dataset for energy-producing SWDS and WWTPs. CH ₄ recovery data		The Danish Energy Agency (DEA)		Prepared due to the obligation of DEA
DCE data-exchange folder: O:\Tech_ENVS-Luft-Emi\Inventory\2019\6_Waste\Level_1b_Processing\5A_Solid_Waste_Disposal	Excel file with the FOD model: swds_fod_model_1940-2017.xls"	AD, EF, Model	IPCC 2000, 2006		-
http://www.dkl.dk	Number for cremations	AD	Association of Danish Crematories	Hanne Ring (hr@dkl.dk)	Public access
http://www.statistikbanken.dk	Statistics for population, buildings and vehicles	AD	Statistics Denmark		Public access
DCE data-exchange folder: O:\Tech_ENVS-Luft-Emi\Inventory\2019\6_Waste\Level_1a_Storage	Cremated animal carcasses	AD	Dansk Dyrekremering ApS	Knud Ribergaard (info@danskdyrekremering.dk)	Personal contact
DCE data-exchange folder: O:\Tech_ENVS-Luft-Emi\Inventory\2019\6_Waste\Level_1a_Storage	Cremated animal carcasses	AD	Ada's Kæledyrs-krematorium ApS	Anders Oxholm (anders@adakrem.dk)	Personal contact
O:\Tech_ENVS-Luft-Emi\Inventory\2019\6_Waste\Level_1a_Storage	Cremated animal carcasses	AD	Kæledyrskrematoriet	Annette Laursen (dyrepen-sion@skyline-mail.dk)	Personal contact
https://statistikbank.brs.dk	Categorized fires	AD	The Danish Emergency Management Agency	Steen Hjere Nonnemann (shn@beredskabsstyrelsen.dk)	Public access
DCE data-exchange folder: O:\Tech_ENVS-Luft-Emi\Inventory\2019\6_Waste\Level_1a_Storage	Waste categories for composting	AD	Danish Environmental Protection Agency (DEPA). Waste Statistics		Public access

7.8.2 Data Processing Level 1

This level comprises a stage where the external data extracted from the waste data system (DEPA, 2014) are processed internally.

For CRF category 5.A, data are prepared for the DCE First Order of Decay model by allocation of the reported waste amounts according to the European Waste Codes (EWC) as presented in Chapter 7.2 and in Annex 3F, Table 3F-2.3 – F-2.5. The model runs in excel and the output are stored inside the excel file.

For the CRF category 5.B, composting data are delivered by the Danish Environmental Protection Agency for the period 2010-2020 at plant level. Total amount of composted bio-waste is extracted from the waste reporting system (www.ads.mst.dk). Regarding the derivation of emission factors used in the model calculations, improvements are documented in Chapter 7.3.

For the CRF category 5.C, activity data are used directly and for category 5.E., the activity data and emission factors are recalculated to match each other by using national average data like the average floor space in houses etc. Calculations are carried out and the output stored in a not editable format each year. The DP at level 1 has been improved to fit into a more uniform and easily accessible data reporting format.

For CRF category 5.D, data are prepared for the input to the country-specific models. The plant level data for WWTPs using anaerobic sludge digestion, i.e. biogas production, have been integrated with plant level energy recovery data from the Energy Statistics and a mass balance for the CH₄ potential in the influent TOW, the ingestate, the digestate, the amount of recovered and lost CH₄ by flaring and venting. Status for the improvements are presented Chapter 7.5 and in Thomsen, 2016. Calculations are carried out and the output stored in a not editable format each year. The DP at level 1 has been improved to fit into a more uniform and easily accessible data reporting format. Regarding the derivation of activity data and emission factors used in the model calculations, improvements are documented in Chapter 7.5.

7.8.3 Data Storage Level 2

Data Storage Level 2 is the placement of selected output data from the calculation of emissions as inventory data on SNAP levels in the Access (CollectER) database.

7.8.4 Data Storage Level 4

Data Storage Level 4 is the placement of the calculated output data from the calculation of emissions as data on SNAP levels in the CRFs.

7.8.5 Points of measurement

The present stage of QA/QC for the Danish emission inventories for the waste sector is described below for DS level 1, 2 and 4 and DP level 1 Points of Measurement (PMs). This is to be seen in connection with the general QA/QC description in Section 1.6 and, especially, 1.6.10 on specific description of PMs common to all sectors, general to QA/QC.

Data Storage level 1	1. Accuracy	DS.1.1.1	General level of uncertainty for every dataset including the reasoning for the specific values
----------------------	-------------	----------	--

The sources of data described in the methodology sections and in DS.1.2.1 and DS.1.3.1 are used in this inventory. Thus, it is the accuracy of these data that define the uncertainty of the inventory calculations.

With regard to the general level of uncertainty for SWDS, the amounts in waste fractions/categories are reasonably certain (per cent uncertainty set equal to 10 %. cf. Table 7.7.1). Due to the statutory environment for these data, while the distribution of waste fractions according to waste type and their content of *DOC* are more uncertain (per cent uncertainty set equal to 20 %. cf. Table 7.7.1). It is generally accepted that FOD models for CH₄ emission estimates offer the best and the most certain way of estimation. The half-life in the FOD models is an important parameter with some uncertainty (cf. Table 7.7.1).

For the *CRF category 5.B Biological Treatment of Solid Waste, 5.C Incineration and open burning and 5.E Other* the level of uncertainty is generally low for activity data but higher for emission factors, cf. Table 7.7.2. Table 7.7.3 and Table 7.7.5. Expert judgments are used whenever default uncertainties are not available.

The input parameter uncertainties for *CRF category 5.D Wastewater Treatment and Discharge* have been derived from standard deviations between activity data extracted from national databases and reported national statistics as shown in Table 7.7.4. Uncertainty of activity data are based on simple standard deviations accompanying the annual reported monitoring data.

Data Storage level 1	2.Comparability	DS.1.2.1	Comparability of the emission factors/calculation parameters with data from international guidelines and evaluation of major discrepancies.
----------------------	-----------------	----------	---

Comparison of Danish data values from external data sources with corresponding data from other countries has been carried out in order to evaluate discrepancies.

Comparison of Danish data values with data sources from other countries has been carried out as presented in the national verification report by Fauser et al., 2007, 2011 and 2013.

Data Storage level 1	3.Completeness	DS.1.3.1	Ensuring that the best possible national data for all sources are included, by setting down the reasoning behind the selection of datasets.
----------------------	----------------	----------	---

SWDS

- Danish Environmental Protection Agency (DEPA). ISAG database and the new waste data system (DEPA, 1996a, 1998a, 1999a, 2001a, 2001b, 2002a, 2004a, 2004b, 2005a, 2006a, 2006b, 2008, 2010a, 2011a, 2014, 2015, 2016, 2017, 2018, 2019, 2020, 2021): amounts of the various waste fractions deposited (refer to Chapter 7.2).
- A Danish investigation and verification of the overall mass balance upon allocating waste fractions within the old ISAG and the new waste data system (DEPA, 2013a, 2014, 2015, 2016, 2017, 2018, 2019, 2020, 2021) into 18 well-defined waste types as described in Chapter 7.2.
- Danish Energy Agency (DEA): Official Danish energy statistics: CH₄ recovery data.

The selection of sources is obvious. The ISAG database is based on statutory registrations and reporting from all Danish waste treatment plants for all

waste entering or leaving the plants. Information concerning waste in the previous year must be reported to the DEPA no later than January 31 each year. Registration is made by mass according to EAK codes, which are automatically reallocated into 18 waste types of which 11 are characterised as inert. The individual waste type characteristics have been documented in Chapter 7.2 and Table 7.2.2 as well as in Annex 3F, Table F3-2.3 and F3-2.5.

For recovery data, the DEA registers the energy produced from plants where installations recover CH₄ in the national energy statistics. For the parameters of the FOD model, references are made to IPCC (2000 and 2006).

Composting

- ISAG Waste Statistics (DEPA, 1996a, 1998a, 1999a, 2001a, 2001b, 2002a, 2004a, 2004b, 2005a, 2006a, 2006b, 2008, 2010a, 2011a, 2014, 2015, 2016, 2017, 2018)
- The New Danish Waste Reporting System (www.ads.mst.dk) (DEPA, 2013, 2014, 2015, 2016, 2017, 2018, 2019)

All Danish waste treatment plants are obligated to statutory registration and reporting of all waste entering and leaving the plants. All waste streams are weighed, categorised with a waste type and a type of treatment and registered to the ISAG waste information system, which contain data for 1995-2009 (ISAG). For 2010-2017 data from the new waste reporting system are delivered by the Danish EPA according to the three compost types (Exclusive home composting).

Waste Incineration

- Tables from Association of Danish Crematories available online
- Direct contact with the Danish animal crematories
- Emission factors from literature.

Data from the Association of Danish Crematories is based on annual reporting from all Danish crematories. Specific reported data are available for the complete time series.

WWTP

- Integrated TOW-Energy recovery database
- The Danish Water Quality Parameter Database (www.miljoportal.dk)

Data plant level on energy recovery has been integrated with plant level data on influent TOW, which have made it possible to quantify the amount of TOW in the influent at plants using anaerobic digestion as sludge management strategy as reported in Table 7.5.3.

Knowledge of the amount of sludge treated at WWTPs with anaerobic sludge digestion has been used as input parameter for calculation of the gross methane emission from anaerobic treatment. It constitutes a major improvement of the activity data for CRF category 5.D, while the energy statistics have been used to quantify the amount of methane lost via venting and flaring.

Other

- Waste Statistics (DEPA, 2017)
- Danish Emergency Management Agency (DEMA) database (DEMA, 2020)
- Emission factors from literature

The waste statistics are based on data from the ISAG database, which is the only Danish registration of waste amounts. Also, the DEMA database is the only provider of data on accidental fires, data for newer years (2007-2019) are extremely detailed.

Data Storage level 1	4.Consistency	DS.1.4.1	The original external data has to be archived with proper reference.
----------------------	---------------	----------	--

Data are predominantly extracted from the internet and databases (The Danish Waste Reporting System, the Water Quality Parameter database, Statistics Denmark, DEMA database, human cremation). The origin of external activity data has been preserved as much as possible by saving them as original copies in their original form. Files are saved for each year of reporting; in this way changes to previously received data and calculations are reflected and explanations are given. Specific information from reports, industries and experts are saved as e-mails and pdf files.

Data Storage level 1	6.Robustness	DS.1.6.1	Explicit agreements between the external institution holding the data and DCE about the conditions of delivery.
----------------------	--------------	----------	---

As stated in DS.1.4.1 most data are obtained from the internet. It is a statutory requirement that amounts of waste are reported annually to DEPA, no later than January 31 for the previous year. No explicit agreements have been made with external institutions.

Data Storage level 1	7.Transparency	DS.1.7.1	Listing of all archived datasets and external contacts.
----------------------	----------------	----------	---

Contact persons related to the delivery of specific data are provided in Table 8.7.1.

For a listing of all archived external data sets the reader is referred to DS 1.3.1.

Data Processing level 1	1. Accuracy	DP.1.1.1	Uncertainty assessment for every data source not part of DS.1.1.1 as input to Data Storage level 2 in relation to type and scale of variability.
-------------------------	-------------	----------	--

No data are used in addition to those included in DS.1.1.1. Uncertainties are reported in Section 7.7.

Data Processing level 1	2.Comparability	DP.1.2.1	The methodologies have to follow the international guidelines suggested by UNFCCC and IPCC.
-------------------------	-----------------	----------	---

The methodological approach is based on the detailed methodology as outlined in the Emission Inventory Guidebook. The calculation used for SWDS is a Tier 2 methodology from IPCC (2000 and 2006). For WWTP the calculations follow the IPCC (2000 and 2006). Exemptions have been documented whenever occurring. The inventory calculations for Waste Incineration and Waste Other are a simple multiplication of activity data and emission factors (See also DS.1.3.1).

Data Processing level 1	3.Completeness	DP.1.3.1	Identification of data gaps with regard to data sources that could improve quantitative knowledge.
-------------------------	----------------	----------	--

Emission factors for cremation and accidental fires are gathered from literature studies. There is no Danish literature or measurements available on greenhouse gas emissions from these categories.

Data Processing level 1	4.Consistency	DP.1.4.1	Documentation and reasoning of methodological changes during the time series and the qualitative assessment of the impact on time series consistency.
-------------------------	---------------	----------	---

There is no change in calculation procedure during the time series and the activity data are, as far as possible, kept consistent for the calculation of the time series. Any changes in calculation procedures are noted for each year's inventory in the individual chapters for each CRF category.

Data Processing level 1	5.Correctness	DP.1.5.1	Verification of calculation results using time series
-------------------------	---------------	----------	---

The time series of activities and emissions from the model output in the SNAP source categories and in the CRF format have been prepared. The time series are examined and significant changes are checked and explained. Comparison is made with the previous year's estimate and any major changes are verified.

Data Processing level 1	5.Correctness	DP.1.5.2	Verification of calculation results using other measures
-------------------------	---------------	----------	--

The correct interpretation in the model/calculation of the methodology and the parameterisation has been checked as far as possible.

Data Processing level 1	7.Transparency	DP.1.7.1	The calculation principle. The equations used and the assumptions made, must be described.
-------------------------	----------------	----------	--

The calculation principle and equations are described in Chapter 7.2 to 7.6 for each CRF category in the waste sector.

Data Processing level 1	7.Transparency	DP.1.7.2	Clear reference to dataset at Data Storage level 1
-------------------------	----------------	----------	--

Refer to the table at the start of this Section and DS.1.1.1 (Table 8.7.1).

The calculation principle and equations are described in Chapter 7.2 to 7.6 for each CRF category in the waste sector.

Data Processing level 1	7.Transparency	DP.1.7.3	A manual log to collect information about recalculations.
-------------------------	----------------	----------	---

Recalculation and changes in the emission inventories are described in the NIR whenever occurring. The logging of the changes takes place in the annual model file.

Data Storage level 2	5. Correctness	DS.2.5.1	Check if a correct data import to level 2 has been made
----------------------	----------------	----------	---

The transfer of emission data from level 1, storage and processing, to data storage level 2 is manually checked. This check is performed, comparing model output and report files made by the CollectER database system.

Data Storage level 4	4. Consistency	DS.4.4.3	The IEFs from the CRF are checked regarding both level and trend. The level is compared to relevant emission factors to ensure correctness. Large dips/jumps in the time series are explained.
----------------------	----------------	----------	--

See DP.1.5.1 and DP.1.5.2.

7.9 Source specific recalculations

Table 7.9.1 presents the recalculations to the waste sector for this year's inventory.

Recalculations have occurred for sector 5.A in the period 2011 to 2018 due to updated activity data. Recalculations have occurred for the whole time series for sector 5B.1 Composting due to updating of activity data for composting of sludge in the period 1990-1994, and CH₄ and N₂O EF values for the waste types GPW, Sludge and Home composting (Chapter 7.3.1), 5.D Wastewater and discharge due to changes in activity data for indirect industrial N₂O emission in the period 1990-1994 and due to updating of the country specific EF for direct N₂O emissions (Chapter 7.5.2) and lastly for sector 5.E Other, due to updated activity data for the whole time series (Chapter 7.6).

The joint effect of these recalculations is a change in the GHG emissions between a maximum decrease of -6.4% in 2003 and maximum increase of 7.6% in 1995. Detailed information about recalculations for the individual sub-sector may be found in sub-chapter 7.91 to 7.9.5 below.

Table 7.9.1 Changes in emissions from the waste sector compared with last year's submission.

	Unit	1990	1995	2000	2005	2010	2015	2016	2017	2018	2019
5.A. Solid Waste Disposal											
CH ₄ , previous inventory	kt	61.5	53.2	42.9	36.4	30.9	26.1	24.8	23.7	23.1	21.4
CH ₄ , recalculated	kt	61.5	53.2	42.9	36.4	30.9	26.1	24.8	23.7	23.1	21.4
Change, CO ₂ equivalents	kt	NA	NA	NA	NA	NA	NA	NA	NA	NA	NA
Change	%	NA	NA	NA	NA	NA	NA	NA	NA	NA	NA
5.B. Biological treatment of Solid Waste											
<i>5.B1 Composting</i>											
CH ₄ , previous inventory	t	1068.2	1448.0	2485.0	2634.6	2959.5	3037.6	3039.7	3290.8	3327.8	3457.4
CH ₄ , recalculated	t	1068.2	1448.0	2485.0	2634.6	2959.5	3037.6	3039.7	3290.8	3327.8	3448.8
N ₂ O, previous inventory	t	74.6	100.9	190.9	189.2	213.5	217.5	218.8	239.3	239.5	249.3
N ₂ O, recalculated	t	74.6	100.9	190.9	189.2	213.5	217.5	218.8	239.3	239.5	245.8
Change, CO ₂ equivalents	Kt	NA	NA	NA	NA	NA	NA	NA	NA	NA	-1.27
Change	%	NA	NA	NA	NA	NA	NA	NA	NA	NA	-0.79
<i>5.B2 Biogas</i>											
CH ₄ , previous inventory	t	224	627	1211	1995	2675	4337.4	6635.4	8282.2	10185.2	12833.3
CH ₄ , recalculated	t	224	627	1211	1995	2675	4337.4	6635.4	7690.6	8487.7	9777.8
Change, CO ₂ equivalents	Kt	NA	NA	NA	NA	NA	NA	NA	-0.59	-1.70	-3.06
Change	%	NA	NA	NA	NA	NA	NA	NA	-7.14	-16.67	-23.81
5.C. Incineration and open burning of waste											
CH ₄ , previous inventory	t	0.51	0.55	0.57	0.62	0.76	0.71	0.73	0.73	0.76	0.75
CH ₄ , recalculated	t	0.51	0.55	0.57	0.62	0.76	0.71	0.73	0.73	0.76	0.75
N ₂ O, previous inventory	t	0.64	0.69	0.71	0.77	0.95	0.89	0.91	0.91	0.95	0.94
N ₂ O, recalculated	t	0.64	0.69	0.71	0.77	0.95	0.89	0.91	0.91	0.95	0.93
Change, CO ₂ equivalents	kt	NA	NA	NA	NA	NA	NA	NA	NA	NA	0.00
Change	%	NA	NA	NA	NA	NA	NA	NA	NA	NA	0.00
5.D. Wastewater treatment and discharge											
CH ₄ , previous inventory	kt	1.64	1.73	1.85	1.89	1.91	1.96	2.01	2.01	2.03	2.09
CH ₄ , recalculated	kt	1.64	1.73	1.85	1.89	1.91	1.96	2.01	2.01	2.03	2.09
N ₂ O, previous inventory	kt	0.80	0.82	0.58	0.56	0.47	0.51	0.49	0.50	0.51	0.48
N ₂ O, recalculated	kt	0.80	0.82	0.58	0.56	0.47	0.51	0.49	0.50	0.51	0.48
Change, CO ₂ equivalents	kt	NA	NA	NA	NA	NA	NA	NA	NA	NA	NA
Change	%	NA	NA	NA	NA	NA	NA	NA	NA	NA	NA
5.E. Other											
CO ₂ , previous inventory	kt	21.69	24.20	22.14	21.59	23.07	21.54	24.33	23.71	24.45	22.99
CO ₂ , recalculated	kt	21.78	24.27	22.16	21.55	23.07	21.58	24.37	23.76	24.49	23.04
CH ₄ , previous inventory	kt	0.11	0.12	0.11	0.11	0.11	0.11	0.12	0.12	0.12	0.11
CH ₄ , recalculated	kt	0.11	0.12	0.11	0.11	0.11	0.11	0.12	0.12	0.12	0.11
Change, CO ₂ equivalents	kt	0.10	0.07	0.03	-0.03	NA	0.04	0.05	0.05	0.05	0.05
Change	%	0.39	0.26	0.10	-0.14	NA	0.18	0.17	0.18	0.17	0.19

7.9.1 Solid waste disposal on land

No recalculations have occurred.

7.9.2 Biological treatment of solid waste

Composting

A minor recalculation has been done for 2019 as a consequence of a correction of an error in the data input.

Anaerobic digestion at biogas facilities

Emissions have been recalculated from 2017 to 2019 due to new information on the emission factor for biogas plants in Denmark. Previously, an emission

factor of 4.2 % has been used for all years based on a Danish study on a limited number of plants. In 2021, the results of a new and far more comprehensive study was published showing that the plants participating in the measurement programme had a lower emission factor than the standard national value. In this submission, a weighted emission factor has been calculated based on the new measurement report and the older measurement report. The emission factor has then been interpolated between 2016 and 2020 causing the changes to the emissions in 2017-2019. More information on the results of the new measurement programme is presented in Chapter 7.3.2.

7.9.3 Waste incineration and open burning

A minor recalculation has been made for 2019 and is due to an error in the number of cremations for 2019 in submission 2021.

7.9.4 Wastewater treatment and discharge

No recalculations have occurred.

7.9.5 Other

A recalculation has been made for vehicle fires due to updated activity data for tractors and combined harvesters for all years 1990-2019.

7.10 Source specific improvements

7.10.1 Response to the review process

A review of the Danish 2020 submission took place in November 2020 and the report was published on 5 May 2021, i.e. after the 2021 submission. Denmark was reviewed in September of 2021, but at the time of preparing this report, Denmark had not yet received a draft review report. Therefore, the table on the next pages represents the latest published report.

Para	CRF	ERT Comment	Denmark's response	Reference
2020 submission (Review report)				
W.2	5.A Solid waste disposal on land – CH ₄	Use the notation key "NA" to report CO ₂ emissions for solid waste disposal on land.	This was resolved for all geographical scopes in the 2021 submission.	See CRF.
W.4	5.A Solid waste disposal on land – CH ₄	Correct the erroneous entry of DOC _f in CRF table 5.A.	In the 2021 submission, the correct value was reported, but as fraction (0.5) rather than percentage (50 %). This has been corrected in the 2022 submission.	See CRF.
W.6	5.A Solid waste disposal on land – CH ₄	Denmark reported in the NIR (table 16.7.4, p.720) that the DOC weighted (after open burning) fraction in dry paper/cardboard for waste disposal and in wet paper/cardboard used to estimate CH ₄ emissions from solid waste disposal in Greenland were 0.40 and 0.20, respectively, and indicated that these values were derived in accordance with the 2006 IPCC Guidelines and the IPCC good practice guidance. However, the 2006 IPCC Guidelines (vol. 5, chap. 2, table 2.4) give the DOC content for wet paper/cardboard and dry paper/cardboard as 40 and 44 per cent, respectively. During the review, the Party explained that some of the DOC values used to estimate CH ₄ emissions from solid waste disposal were not updated in accordance with the 2006 IPCC Guidelines. Denmark confirmed that it will use the correct DOC values from the 2006 IPCC Guidelines for the next submission. The ERT recommends that Denmark recalculate CH ₄ emissions from solid waste disposal in Greenland using the correct values of DOC for dry and wet paper/cardboard in line with the 2006 IPCC Guidelines (vol. 5, chap. 2, table 2.4).	This only relates to Greenland and has been addressed in the 2022 submission.	See Chapter 16.
W.7	5.A.1 Managed waste disposal sites – CH ₄	According to the NIR (section 7.2.1, p.523), Denmark used an oxidation factor of 0.1 from the 2006 IPCC Guidelines (vol. 5, chap. 3, table 3.2), which corresponds to managed SWDS covered with CH ₄ oxidizing material, in its model for estimating CH ₄ emissions from solid waste disposal. However, the Party did not provide sufficient justification as to why this oxidation factor value is applicable to Denmark. During the review, Denmark provided detailed information justifying its choice of oxidation factor and explained that, as Danish landfills were covered with a soil top layer, the requirements of the 2006 IPCC Guidelines are met for the whole time series 1990–2018. The ERT recommends that the Party include in its NIR a detailed explanation on its choice of oxidation factor for managed SWDS in Denmark.	This was addressed in the 2021 submission, see p. 532 of the 2021 NIR.	
W.8	5.A.1 Managed waste disposal sites – CH ₄	The Party did not transparently describe in the NIR (section 7.2.1, p.523) the parameters used to estimate CH ₄ recovery in managed SWDS in NIR equation 7.2.8. The NIR did not contain the definitions of the parameters, the sources of input data or the specific values chosen. During the review, Denmark provided detailed information on the parameters used to estimate CH ₄ recovery in NIR equation 7.2.8. The ERT recommends that Denmark include in the NIR a detailed description of the parameters used to estimate CH ₄ recovery in managed SWDS, including definitions of all input parameters, sources of the input data and the values chosen.	This was addressed in the 2021 submission, see p. 547 of the 2021 NIR.	
W.9	5.A.1 Managed waste disposal sites – CH ₄	The statement in the NIR (section 7.2.1, p.523) that the CH ₄ recovered was reported in NIR tables 7.2.1 and 7.2.9 in kt is inaccurate because the NIR does not include a table 7.2.9. During the review, the Party explained that the amount of recovered CH ₄ was reported in NIR tables 7.2.1 (p.520) and 7.2.6 (p.527) in kt. The ERT recommends that Denmark ensure that the references to NIR tables relating to CH ₄ recovered from solid waste disposal are correct in the NIR.	This was not addressed in the 2021 submission, but has been corrected in the 2022 submission.	See Chapter 7.2.
W.10	5.A.1 Managed waste disposal sites – CH ₄	According to NIR equation 7.2.9 (p.525), CH ₄ generation potential can be estimated as $Lo_i/W_i = DOC_f \times MCF \times F \times 16/12 \cdot DOC_i$, where $Lo_i/W_i = 0.27 \times DOC_i$. However, the two parts of the equation are not consistent. During the review,	This was not addressed in the 2021 submission, but has been corrected in the 2022 submission.	See Chapter 7.2.3.

Para	CRF	ERT Comment	Denmark's response	Reference
		Denmark explained that the coefficient in equation 7.2.9 should be 0.33 rather than 0.27 (i.e. $Lo_i/W_i = 0.33 \times DOC_i$) and indicated that the typographical error will be corrected for the next submission. The ERT noted that the incorrect value of the coefficient in NIR equation 7.2.9 did not lead to errors in the Party's estimation of CH ₄ emissions. The ERT recommends that the Party correct the equation used for estimating the CH ₄ generation potential by using the correct value for the coefficient (0.33).		
W.11	5.B.1 Composting – CH ₄ and N ₂ O	Denmark reported in CRF table summary 3s2 that it used tier 1 and country-specific methods to estimate and report CH ₄ and N ₂ O emissions from biological treatment of solid waste (category 5.B), including composting (subcategory 5.B.1). However, according to the NIR (section 7.3.1, p.529), emissions from composting were calculated using both IPCC default EFs and other country-specific EFs, which corresponds to a hybrid approach incorporating tier 1 and 2 methodologies. During the review, Denmark explained that, in general, it applied a mix of tier 1 and 2 methodologies for estimating CH ₄ and N ₂ O emissions from waste composting: CH ₄ emissions from composting of garden and park waste and N ₂ O emissions from composting of sludge were estimated using a tier 2 method, while the remaining emissions were estimated using tier 1 methods. The ERT recommends that Denmark accurately report the methodological tiers used to estimate CH ₄ and N ₂ O emissions from composting in CRF table summary 3s2, ensuring consistency with the NIR.	This was not addressed in the 2021 submission, but has been corrected in the 2022 submission.	See CRF.
W.12	5.B.1 Composting – CH ₄ and N ₂ O	The Party stated in the NIR (section 7.3.1, p.528) that information on GHGs emitted from composting (CH ₄ , N ₂ O and CO ₂) is presented in NIR table 7.3.1. However, NIR table 7.3.1 does not include information on CO ₂ emissions. During the review, Denmark acknowledged that the inclusion of CO ₂ in the above-mentioned list of gases is incorrect and was caused by a typographical error. The ERT recommends that Denmark correct the reference in the NIR to the GHGs emitted from composting by clarifying that only CH ₄ and N ₂ O emissions are estimated for composting.	This was not addressed in the 2021 submission, but has been corrected in the 2022 submission.	See Chapter 7.3.1.
W.13	5.B.1 Composting – CH ₄ and N ₂ O	Denmark reported sludge composted in the NIR (table 3F-3.2, annex 3F) as 6.348 Gg for 1995–2018 and as "NO" for 1990–1994. The Party explained in the NIR (section 5.3.1, p.531) that the amount of sludge composted was reported as "NO" for 1990–1994 because it does not demonstrate a convincing trend and therefore cannot be used to estimate the AD for previous years, and also stated that this activity was insignificant in 1995–1997 (1–2 per cent). However, the Party did not provide information in the NIR to support the assumption that no sludge was composted in 1990–1994. In addition, Denmark did not provide justification for the exclusion in terms of the likely level of emissions being below 0.05 per cent of national total GHG emissions without exceeding 500 kt CO ₂ eq, as per paragraph 37(b) of the UNFCCC Annex I inventory reporting guidelines. During the review, Denmark explained that it plans to provide conservative estimates in the next submission and use the average amount composted in 1995–1997 (6.7 kt) to report the amount of sludge composted in 1990–1994. The ERT recommends that Denmark use appropriate splicing techniques, as described in the 2006 IPCC Guidelines (vol. 1, chap. 5), to estimate AD for sludge composting for 1990–1994 and only report a conservative estimate if none of the splicing techniques can be used appropriately for Denmark.	This was addressed in the 2021 submission, see p. 556 of the 2021 NIR.	
W.14	5.B.1 Composting – CH ₄ and N ₂ O	According to the NIR (section 7.3.2, p.533), emissions from anaerobic digestion at wastewater treatment plants are included in the inventory under CRF category 5.B (wastewater treatment and discharge). However, the CRF code for wastewater treatment and discharge is 5.D. During the review, Denmark acknowledged that the CRF code for wastewater treatment and discharge was incorrectly given as category 5.B in the NIR owing to a typographical error,	This was addressed in the 2021 submission, see p. 560 of the 2021 NIR.	

Para	CRF	ERT Comment	Denmark's response	Reference
		and the category should be given as 5.D. The ERT recommends that the Party correct the category code for wastewater treatment and discharge provided in the NIR.		
W.15	5.B.1 Composting – CH ₄ and N ₂ O	The NIR does not transparently describe the estimation of CH ₄ and N ₂ O emissions for the subcategories composting of garden and park waste and home composting of garden and vegetable food waste, for example by explaining how the country-specific EFs presented in NIR table 7.3.4 were derived. Moreover, the NIR (section 7.3.1, p.532) cites a publication (Boldrin et al., 2009) that is not included in the list of references (p.574). During the review, Denmark provided the ERT with clear and detailed information on how the country-specific EFs for CH ₄ and N ₂ O emissions were derived for the above-mentioned subcategories, including an example estimation. These details enabled the ERT to understand all the inputs, coefficients and assumptions used in the estimation methodology. The ERT recommends that Denmark include detailed information on the estimation of CH ₄ and N ₂ O emissions from composting of garden and park waste and from home composting of garden and vegetable food waste, including detailed equations, descriptions of all the input data and parameters, and references to relevant publications justifying the suitability of the equations and parameters used.	This was addressed in the 2021 submission, see p. 557-559 of the 2021 NIR.	
W.16	5.B.1 Composting – CH ₄ and N ₂ O	Denmark did not estimate and report CH ₄ or N ₂ O emissions from waste composting for Greenland. During the review, the Party explained that this is because Greenland has an arctic climate and mostly consists of rocks with very little soil. Therefore, it is not a suitable place for composting waste because, in addition to the difficulties that sub-zero temperatures present for composting, there is no use for compost in such a climate. The ERT agreed with the response provided by the Party. The ERT recommends that the Party explain why CH ₄ and N ₂ O emissions from biological treatment of waste (category 5.B) are not estimated and reported for Greenland in the NIR.	This relates to Greenland only and has been addressed in the 2022 submission.	See Chapter 16.
W.17	5.B.1 Composting – CH ₄ and N ₂ O	The Party did not estimate CH ₄ or N ₂ O emissions from waste composting for the Faroe Islands, but according to the NIR (annex 7, p.892) waste composting does occur there. During the review, the Party explained that it plans to include CH ₄ and N ₂ O emissions from waste composting for the Faroe Islands in the 2021 or 2022 submission on the basis of the results of an ongoing project to improve the GHG inventory of the Faroe Islands. The ERT recommends that Denmark estimate CH ₄ and N ₂ O emissions from waste composting for the Faroe Islands.	This relates to the Faroe Islands only and has been addressed in the 2022 submission.	See Annex 7.
W.18	5.B.2 Anaerobic digestion at biogas facilities – CH ₄	In the equation used to estimate CH ₄ emissions from anaerobic digestion of organic waste at biogas facilities (NIR equation 7.3.1, p.535), the EF used (0.42) is equal to the weighted average of nine biogas plants. However, the NIR (section 7.3.2, p.535) also states that the weighted average for the nine plants was 4.2 per cent, and as such the EF should be 0.042 rather than 0.42. During the review, Denmark acknowledged that the EF (0.42) was incorrectly reported because of a typographical error and explained that it will be corrected in the next submission. However, the ERT noted that the Party calculated CH ₄ emissions using an EF of 0.042, and therefore the incorrect reporting did not lead to an overestimation of emissions. The ERT recommends that the Party ensure that the correct EF value is given in the equation used to estimate emissions from anaerobic digestion of organic waste at biogas facilities.	This was not addressed in the 2021 submission, but has been corrected in the 2022 submission.	See Chapter 7.3.2.
W.19	5.B.2 Anaerobic digestion at biogas facilities – CH ₄	According to the NIR (table 7.3.6, p.535), CH ₄ production from anaerobic digestion of organic waste at biogas facilities in 2018 was estimated at 240,078 t CH ₄ , which was calculated as biogas production (12,244 TJ) divided by net calorific value (50 MJ/kg). However, this calculation does not produce the value 240,078 t CH ₄ . During the review, Den-	This was addressed in the 2021 submission.	

Para	CRF	ERT Comment	Denmark's response	Reference
		<p>mark explained that this was due to an error in the calculation, whereby a net calorific value of 51 MJ/kg was used instead of 50 MJ/kg. The Party also explained that dividing biogas production in 2018 (12,244 TJ) by the correct net calorific value (50 MJ/kg) results in 244,879 t CH₄ produced instead of 240,078 t CH₄. The ERT noted that this error led to emissions being underestimated by 202 t CH₄ (5.05 kt CO₂ eq) for the category for 2018, which is below the threshold of significance for Denmark, as per paragraph 37(b) of the UNFCCC Annex I inventory reporting guidelines and for the application of an adjustment in accordance with decision 22/CMP.1, annex, paragraph 80(b), in conjunction with decision 4/CMP.11. The Party explained that the error will be corrected in the next submission.</p> <p>The ERT recommends that Denmark recalculate CH₄ emissions from anaerobic digestion of organic waste at biogas facilities for 2018 using the correct net calorific value (50 MJ/kg) instead of the incorrect value used for the 2020 submission (51 MJ/kg).</p>		
W.20	5.B.2 Anaerobic digestion at biogas facilities – CH ₄	<p>Denmark reported the amount of CH₄ for energy recovery from anaerobic digestion at biogas facilities as “NO” for the entire time series in CRF table 5.B. However, CH₄ recovery from anaerobic digestion of organic waste could be easily estimated using the information on CH₄ production and emissions provided in the NIR (table 7.3.6). During the review, Denmark explained that data on biogas production are compiled by the Danish Energy Agency as part of Denmark's national energy statistics, and that, while historically biogas has mainly been used directly in gas engines to produce electricity and heat, parts of the biogas network were upgraded and fed into the natural gas network.</p> <p>The ERT recommends that Denmark estimate and report the amount of CH₄ for energy recovery in CRF table 5.B rather than reporting it as “NO”.</p>	This was not addressed in the 2021 submission, but has been implemented in the 2022 submission.	See CRF.
W.21	5.C.1 Waste incineration – CH ₄ and N ₂ O	<p>Denmark did not clarify whether the EFs for CH₄ and N₂O emissions from human and animal cremation provided in the NIR (tables 7.4.4 and 7.4.7) include CH₄ and N₂O emissions from fuel combusted for the purpose of the cremation and whether the fuel used for human and animal cremation is included in the Danish energy balance. In addition, the document referred to in the NIR (Aasestad, 2008) in relation to the CH₄ and N₂O EFs for human and animal cremation does not explain how the CH₄ and N₂O EFs were derived. During the review, Denmark explained that, although the Danish energy balance includes all fuels used, the information it provides is not detailed enough to enable the identification of fuels used in crematoria. The Party further explained that to the best of its knowledge, the EFs were estimated without accounting for the contribution of emissions from fuel combustion (i.e. including only emissions from the incineration of the corpse/carcass and the casket or other storage materials).</p> <p>The ERT recommends that Denmark include in the NIR information on how the CH₄ and N₂O EFs for human and animal cremation were derived, including whether the contribution of any emissions from the fuels used was considered when deriving the EFs.</p>	This was not addressed in the 2021 submission, but has been addressed in the 2022 submission.	See Chapter 7.4.1 and 7.4.2.
W.22	5.C.1 Waste incineration – CO ₂ , CH ₄ and N ₂ O	<p>According to the NIR (section 7.4, p.537), the AD for waste incineration are the number (or mass when estimated) of human corpses and animal carcasses cremated, as provided in the relevant tables (tables 7.4.3 and 7.4.6). However, while Denmark reported AD for animal cremation in CRF table 5.C, it reported the AD for human cremation as “NO” without providing any explanation for the use of the notation key. During the review, Denmark explained that the calculation of emissions from the cremation of human corpses is based on EFs per body, while emissions from the cremation of animal carcasses were calculated using EFs per weight unit. Given that the weights of deceased persons are not known, the AD cannot be reported in kt as required in CRF table 5.C. Denmark also explained that it plans to include an explanation in the documentation box of CRF table 5.C and</p>	This was not addressed in the 2021 submission, but has been corrected in the 2022 submission as the Notation Key has been changed to NE. There are some technical difficulties in adding the explanation in the documentation box, but we trust that the documentation provided in this report is sufficient.	See CRF.

Para	CRF	ERT Comment	Denmark's response	Reference
		to report the AD as "NE" rather than "NO" in future submissions. The ERT recommends that Denmark report the AD on the amount of waste incinerated for human cremation as "NE" instead of "NO" in CRF table 5.C and provide a corresponding explanation in a documentation box.		
W.23	5.C.1 Waste incineration – CO ₂ , CH ₄ and N ₂ O	Denmark did not provide in the NIR information on the estimation of CO ₂ , CH ₄ and N ₂ O emissions from waste incineration in the Faroe Islands, such as the derivation of EFs and the calorific values used, clarification of whether the same calorific value was used for fossil and biogenic waste, analyses of the trends for non-CO ₂ EFs, and the composition of the incinerated waste and how the fossil share was derived. During the review, the Party explained that the CO ₂ EFs used for the Faroe Islands are the same as those used for mainland Denmark. The Party further explained that the CH ₄ and N ₂ O EFs were provided in the NIR (table 6, p.896), while the annual amount of waste incinerated is shown in NIR figure 20 (p.893). The ERT recommends that Denmark include in the NIR information on: (a) The derivation of CO ₂ , CH ₄ and N ₂ O EFs; (b) Analyses of the trends for non-CO ₂ EFs; (c) The derivation of the calorific value of incinerated waste, clarifying whether the same calorific value was used for fossil and biogenic waste; (d) The composition of the incinerated waste (if available) and how the fossil share was derived.	This was addressed in the 2021 submission. More detailed information has been included on EF and NCV selection related to the estimation of CO ₂ , CH ₄ and N ₂ O emissions from waste incineration in the Faroe Islands in its NIR (presented on p.934 with background information in chapter 3, pages 126-127, 132, 137-141, 146, 148-151, and p.822-824)	
W.24	5.D.1 Domestic wastewater – CH ₄	Denmark stated in the NIR (section 7.5.2, p.545) that, starting with the 2019 inventory submission, it used a revised EF for calculating CH ₄ emissions from septic tanks, moving from the default value of 0.125 kg CH ₄ /kg COD (equal to 0.25 × 0.5) from the 2006 IPCC Guidelines (vol. 5, chap. 6, tables 6.2–6.3) to a country-specific value (0.047 kg CH ₄ /kg COD). This revised EF was calculated using a country-specific value for the CH ₄ conversion factor which, in turn, was calculated using the CH ₄ emission measurements provided in a publication (Nielsen et al., 2018). As a result, Denmark revised its estimates of CH ₄ emissions from domestic wastewater treatment, leading to a decrease in estimated emissions of 54.63–57.22 per cent for the whole time series (1990–2016) in the 2019 submission. The Party mentioned in the NIR (section 7.5.2, p.545) that the country-specific EF was derived by applying an "uncertainty factor" of 10 to account for the fact that the installed septic tanks are older and may not be functioning optimally. As such, the EF value was reduced by a factor of 2.6 (i.e. from 0.125 to 0.047). However, the Party did not provide sufficiently detailed information on the derivation of the country-specific EF, in particular information on the methodology and parameters used to estimate CH ₄ emissions from septic tanks, including references to relevant publications and a justification that the EF was determined in a scientifically sound manner. In addition, NIR equation 7.5.6 gave incorrect units of measurement for the EF (kg CH ₄ /kg DOC instead of kg CH ₄ /kg COD). During the review, Denmark provided the information requested by the ERT, including a detailed description of the equations used (NIR equations 7.5.5–7.5.6) and the expert judgment used to derive the country-specific EF. The Party explained that the EF was determined using an expert judgment based on measurements carried out over three months on two septic tanks. In response to the draft review report, the Party further explained that the factor of 10 does not represent the uncertainty of the country-specific EF but instead is a factor of safety used to make a conservative estimate of the CH ₄ emissions from septic tanks in Denmark, given that the two septic tanks used in the above-mentioned study are not representative of the whole of Denmark. The ERT recommends that Denmark enhance the transparency of its reporting by: (a) Correcting the units of measurement for the EF (EF _{st}) presented in NIR equation 7.5.6 (kg CH ₄ /kg COD instead of	This was partly addressed in the 2021 submission as it related to bullet b-d. However, the units in equation 7.5.6 had unfortunately not been corrected. This has been done in this submission.	See equation 7.5.6.

Para	CRF	ERT Comment	Denmark's response	Reference
		<p>kg CH₄/kg DOC);</p> <p>(b) Providing detailed and transparent information on the methodology used to estimate CH₄ emissions from septic tanks;</p> <p>(c) Explaining all the parameters used to estimate CH₄ emissions from septic tanks and including accurate references to justify them;</p> <p>(d) Stating clearly in the NIR that the factor of 10 is based on expert judgment and was applied to make a conservative estimate of the EF for CH₄ emissions from septic tanks in Denmark;</p> <p>(e) Explaining how the revision of CH₄ emissions from septic tanks due to the use of the country-specific CH₄ EF affected uncertainty estimates of CH₄ emissions from wastewater handling.</p>		
W.25	5.D.1 Domestic wastewater – CH ₄	<p>Denmark stated in the NIR (section 7.5.2, p.545) that the country-specific EF used for calculating CH₄ emissions from septic tanks (0.047 kg CH₄/kg DOC) was derived using an “uncertainty factor” of 10. In response to the draft review report, Denmark provided further clarification regarding the uncertainty factor (see ID# W.24 above).</p> <p>The ERT recommends that Denmark consider revising the methodology used to derive the country-specific CH₄ EF for septic tanks with a view to making it accurate and representative of the management practices in Denmark</p>	This was addressed in the 2021 submission, see p. 570 of the 2021 NIR.	
W.26	5.D.1 Domestic wastewater – CH ₄	<p>According to the NIR (section 7.5.1, p.541), Denmark assumed the share of the population not connected to the sewer system (i.e. scattered houses) to be 10 per cent. However, the NIR did not state the basis for this assumption or provide a justification that it did not lead to an underestimation or overestimation of CH₄ emissions from septic tanks. Moreover, it was not clear whether the share is constant and equal to 10 per cent for the whole time series (1990–2018). During the review, Denmark explained that, although the share of scattered houses is assumed to remain constant at 10 per cent on the basis of an expert judgment, this assumption is consistent with Eurostat data on the percentage of the Danish population connected to urban wastewater collection and treatment systems, which increased from 89.7 to 91.9 per cent between 2009 and 2017. Denmark explained that it plans to recalculate CH₄ emissions from septic tanks for the whole time series by using the data on the percentage of scattered houses reported to Eurostat for 2007 onward, while keeping a constant level for 1990–2006.</p> <p>The ERT recommends that Denmark estimate CH₄ emissions from septic tanks using existing data on the percentage of scattered houses from relevant data sources (e.g. Eurostat). If no data on the population living in scattered houses are available for 1990–2006, the ERT recommends that Denmark use appropriate splicing techniques as described in the 2006 IPCC Guidelines (vol. 1, chap. 5).</p>	This was addressed in the 2021 submission, see p. 565 and 570 of the 2021 NIR.	
W.27	5.D Wastewater treatment and discharge – CH ₄ and N ₂ O	<p>Denmark reported in CRF table summary 3s2 that N₂O emissions from wastewater treatment and discharge were estimated using a tier 1 method for 1990–2016, a combination of tier 1 and 2 methods for 2017 and a combination of tier 2 and 3 methods for 2018. However, Denmark did not explain whether it used consistent methodologies to estimate CH₄ and N₂O emissions from different wastewater treatment and discharge sources across the whole time series. During the review, Denmark explained that the 2006 IPCC Guidelines do not specify which methodological tiers should be used for estimating N₂O emissions from wastewater treatment, which complicates reporting on the level of methodological tiers used. Denmark explained that the methodology was applied consistently for the whole time series, maintaining the same level of detail in AD (monitoring data on total organic content in influents and effluents and N and energy production from anaerobic digestion of sludge) and using the country-specific EF values for N₂O and CH₄. For the share of the population not connected to the sewer system, Denmark introduced a country-specific EF value for</p>	This was addressed in the 2021 submission by updating the CRF (Summary Table 3s2) related to methods and EFs used for estimating N ₂ O emissions from industrial wastewater treatment plants and by including greater explanation for the methodology in the 2021 NIR (p.566 and p.574).	

Para	CRF	ERT Comment	Denmark's response	Reference
		<p>2018. For direct emissions from industrial wastewater treatment, the Party developed a method for backcasting emissions on the basis of the amount of effluent N on a national scale. The ERT noted that including this explanation in the NIR would enhance the transparency of reporting. Further, in response to the review report, Denmark confirmed that there was a mistake in CRF table summary 3s2 for the reported tier level of the N₂O emissions and explained that country-specific monitoring data for the AD and default EF value were applied for wastewater discharge, and that country-specific AD and EFs were applied for direct emissions for the whole time series.</p> <p>The ERT recommends that Denmark:</p> <p>(a) Ensure that the tier levels of methods used for estimating N₂O emissions are reported correctly in CRF table summary 3s2 for the whole time series;</p> <p>(b) Explain in the NIR the method applied for backcasting direct emissions from industrial wastewater treatment plants.</p>		
W.28	5.E Other (waste) – N ₂ O	<p>Denmark reported N₂O emissions from accidental fires as "NA" in CRF tables 5 and summary 2, but did not explain why this notation key was used. In addition, according to the 2006 IPCC Guidelines (vol. 5, chap. 5, p.5.5), incineration and open burning of waste lead to CO₂, CH₄ and N₂O emissions. During the review, Denmark explained that it did not report N₂O emissions because EFs and other parameters for accidental fires were not available, as they differ from those for incineration and open burning activities, for which default EFs are provided in the 2006 IPCC Guidelines. The ERT noted that this calls for the reporting of "NE" rather than "NA".</p> <p>The ERT recommends that Denmark report N₂O emissions from accidental fires as "NE" instead of "NA" in CRF tables 5 and summary 2, and correct the reporting in the NIR accordingly.</p>	This was not addressed in the 2021 submission, has been addressed in the 2022 submission.	See CRF.

7.10.2 Planned improvements

There are no planned improvements for the waste sector.

7.11 References

Aasestad, K., 2008: The Norwegian Emission Inventory 2008. Documentation of methodologies for estimating emissions of greenhouse gases and long-range transboundary air pollutants. Available at: http://www.ssb.no/english/subjects/01/04/10/rapp_emissions_en/rapp_200848_en/rapp_200848_en.pdf (02/02-2022).

Adouani, N., Lendormi, T., Limousy, L., Sire, O., 2010: Effect of the carbon source on N₂O emissions during biological denitrification. Resources, Conservation and Recycling 54(5), 299-302. Available at: <https://doi.org/10.1016/j.resconrec.2009.07.011> (07/02-2021).

Amlinger, F., Peyr, S. & Cuhls, C., 2008: Greenhouse gas emissions from composting and mechanical biological treatment. Florian Amlinger. Stefan Peyr and Carsten Cuhls. Waste Management & Research 2008, 26, 47. Sage publications. International Solid Waste Association. Available at: <http://wmr.sagepub.com/cgi/reprint/26/1/47.pdf> (18/12-2020).

Andersen, J.K., Boldrin, A., Samuelsson, J., Christensen, T.H. & Scheutz, C. 2010: Quantification of greenhouse gas emissions from windrow composting of garden waste. J Environ Qual. 2010 Feb 19;39(2):713-24. doi: 10.2134/jeq2009.0329. PMID: 20176844. (07/02-2021).

Biogasbranchen, 2019: Frivilligt måleprogram for metantab. Bruno Sander Nielsen, Biogasbranchen. GASenergi, Nr. 3, 2019. https://www.danskgasforening.dk/sites/default/files/inline-files/4_%20Frivilligt%20m%C3%A5leprogram.pdf (08-02-2022)

Blomqvist, P., Persson, B. & Simonson, M., 2002: Utsläpp från bränder till miljön. Utsläpp av dioxin. PAH och VOC till luften. Räddningsverket. Karlstad. FoU rapport. SP Brandteknik. Borås. Available at: <http://rib.msb.se/Filer/pdf%5C18193.pdf> (02/02-2022) (Swedish).

Boldrin, A., Andersen, J.K., & Christensen, T.H. 2009: LCA-report: Environmental assessment of garden waste management in Århus Kommune (Miljøvurdering af haveaffald i Århus Kommune). Department of Environmental Engineering, Technical University of Denmark.

Boldrin, A. & Christensen, T.H. 2010: Seasonal generation and composition of garden waste in Aarhus (Denmark). Waste Management 3, 551-557. Available at: doi:10.1016/j.wasman.2009.11.031 (07/02-2021).

Czepiel, P., Crill, P. & Harriss, R. 1995: Nitrous oxide emissions from municipal wastewater treatment. Environmental Science and Technology. 29. 2352-2356. Available at: <https://pubs.acs.org/doi/abs/10.1021/es00009a030> (07/02-2021).

DEMA, 2007: The Danish Emergency Management Agency (DEMA). Beredskabsstyrelsen. Redningsberedskabets Statistiske Beretning 2007.

DEMA, 2017: The Danish Emergency Management Agency (DEMA). Beredskabsstyrelsen. Data received per mail.

DEMA, 2021: The Danish Emergency Management Agency (DEMA). Beredskabsstyrelsen. Statistikbanken. Available at: <https://statistikbank.brs.dk/sb#page=1c572bbd-e3fe-40cf-bc71-4244c3b750e8> (In Danish) (02/02 2022).

Danish Energy Agency (DEA), 2015: Drivhusgasemissioner fra biogasanlæg (English title: GHG emissions from biogasplants). Available at: https://ens.dk/sites/ens.dk/files/Bioenergi/cowi_-_drivhusgasemissioner_fra_biogasanlaeg_v3_4.pdf (07/02-2021).

Danish Energy Agency (DEA), 2020a: The Danish energy statistics. Available at: <https://ens.dk/service/statistik-data-noegletal-og-kort/maanedlig-og-aarlig-energistatistik> (07/02-2021).

Danish Energy Agency (DEA), 2020b: The Danish energy statistics. Energi-producenttællingen 1990-2019, unpublished.

Danish Environmental Protection Agency (DEPA), 1974: Vejledning for kontrollerede lossepladser. Placering, indretning og drift. Vejledning fra Miljøstyrelsen. Vejledning nr. 1/74. Available at: <https://www2.mst.dk/Udgiv/publikationer/1974/87-503-1633-8/pdf/87-503-1633-8.pdf> (08-02-2021)

Danish Environmental Protection Agency (DEPA), 1993: Affaldsstrømmene i Danmark. Arbejdsrapport fra Miljøstyrelsen Nr. 15 1993. Available at: <https://www2.mst.dk/Udgiv/publikationer/1993/87-7909-716-2/pdf/87-7909-716-2.pdf> (07/02-2021).

Danish Environmental Protection Agency (DEPA), 1994: Point Sources 1993. In Danish: Punktkilder 1993. Orientering fra Miljøstyrelsen. nr. 8. Available at: <http://www2.mst.dk/Udgiv/publikationer/1994/87-7810-279-0/pdf/87-7810-279-0.pdf> (07/02-2021).

Danish Environmental Protection Agency (DEPA), 1996a: Affaldsstatistik 1995 (Waste Statistics 1995. Orientering fra Miljøstyrelsen nr. 14 1997) Available at: <http://www2.mst.dk/Udgiv/publikationer/1996/87-7810-704-0/pdf/87-7810-704-0.pdf> (07/02-2021).

Danish Environmental Protection Agency (DEPA), 1996b: Point Sources 1995. In Danish: Punktkilder 1995. Orientering fra Miljøstyrelsen. nr. 16. Available at: <http://mst.dk/service/publikationer/publikationsarkiv/1997/jan/punktkilder-1995/> (07/02-2021).

Danish Environmental Protection Agency (DEPA), 1997: Affaldsstatistik 1996. Orientering fra Miljøstyrelsen. Nr. 13. <https://mst.dk/service/publikationer/publikationsarkiv/1997/nov/affaldsstatistik-1996/> (08-02-2021)

Danish Environmental Protection Agency (DEPA), 1997: Point Sources 1996. In Danish: Punktkilder 1996. Orientering fra Miljøstyrelsen. nr. 16. Available at: <http://mst.dk/service/publikationer/publikationsarkiv/1998/feb/punktkilder-1996/> (07/02-2021).

Danish Environmental Protection Agency (DEPA), 1998a: Waste Statistics 1996. Available at: <http://mst.dk/service/publikationer/publikationsarkiv/1997/nov/affaldsstatistik-1996/> (07/02-2021).

Danish Environmental Protection Agency (DEPA), 1998b: Point Sources 1997. In Danish: Punktkilder 1997. Orientering fra Miljøstyrelsen. nr. 9. Available at: <http://mst.dk/service/publikationer/publikationsarkiv/1998/dec/punktkilder-1997/> (07/02-2021).

Danish Environmental Protection Agency (DEPA), 1999a: Waste Statistics 1997. Available at: <http://mst.dk/service/publikationer/publikationsarkiv/1999/jun/affaldsstatistik-1997/> (07/02-2021).

Danish Environmental Protection Agency (DEPA), 1999b: Point Sources 1998. In Danish: Punktkilder 1998. Orientering fra Miljøstyrelsen. nr. 6. Available at: <http://mst.dk/service/publikationer/publikationsarkiv/2000/jan/punktkilder-1998/> (07/02-2021).

Danish Environmental Protection Agency (DEPA), 1999c: Spildevandsslam fra kommunale og private renselanlæg i 1997 (In English: Sewage sludge from municipal and private wastewater treatment plants in 1997). Miljøprojekt nr. 473. Available at: <https://www2.mst.dk/Udgiv/publikationer/1999/87-7909-330-2/pdf/87-7909-330-2.pdf> (07/02-2021).

Danish Environmental Protection Agency (DEPA), 2000a: Point Sources 1999. In Danish: Punktkilder 1999. Orientering fra Miljøstyrelsen. nr. 16. Available at: <http://www2.mst.dk/Udgiv/publikationer/2000/87-7944-298-6/pdf/87-7944-299-4.pdf> (07/02-2021).

Danish Environmental Protection Agency (DEPA), 2000b: Waste Statistics 1999. Available at: <http://mst.dk/service/publikationer/publikationsarkiv/2000/dec/af-faldsstatistik-1999/> (07/02-2021).

Danish Environmental Protection Agency (DEPA), 2001a: Waste Statistics 1998. Available at: <http://mst.dk/service/publikationer/publikationsarkiv/2000/jan/af-faldsstatistik-1998/> (07/02-2021).

Danish Environmental Protection Agency (DEPA), 2001b: Point Sources 2000. In Danish: Punktkilder 2000. Orientering fra Miljøstyrelsen. nr. 13. Available at: <http://mst.dk/service/publikationer/publikationsarkiv/2001/dec/punktkilder-2000/> (07/02-2021).

Danish Environmental Protection Agency (DEPA), 2001c: Methodology for risk assessment of gas producing landfills. In Danish Metode til risikovurdering af gasproducerende lossepladser. Miljøprojekt nr. 648. Available at: <https://www2.mst.dk/Udgiv/publikationer/2001/87-7944-831-3/pdf/87-7944-832-1.pdf> (08-02-2021)

Danish Environmental Protection Agency (DEPA), 2001d: Waste Statistics 2000. Available at: <http://mst.dk/service/publikationer/publikationsarkiv/2001/dec/af-faldsstatistik-2000/> (07/02-2021).

Danish Environmental Protection Agency (DEPA), 2002: Point Sources 2001. In Danish: Punktkilder 2001. Orientering fra Miljøstyrelsen. nr. 7. Available at: <http://www2.mst.dk/Udgiv/publikationer/2002/87-7972-384-5/pdf/87-7972-385-3.pdf> (07/02-2021).

Danish Environmental Protection Agency (2002): Vejledning om overgangsplaner – Udarbejdelse af overgangsplaner for bestående deponeringsanlæg. Nr. 5. Available at: <https://www2.mst.dk/udgiv/publikationer/2002/87-7972-231-8/pdf/87-7972-231-8.pdf> (07/02-2021).

Danish Environmental Protection Agency (DEPA), 2003a: Point Sources 2002. In Danish: Punktkilder 2002. Orientering fra Miljøstyrelsen. nr. 10. Available at: <http://www2.mst.dk/Udgiv/publikationer/2003/87-7614-074-1/pdf/87-7614-076-8.pdf> (07/02-2021).

Danish Environmental Protection Agency (DEPA), 2003b: Hvad koster der at reducere CO₂-mankoen? Reduktionspotentiale og omkostninger I udvalgte sektorer. Arbejdsrapport no. 7. Available at: <https://www2.mst.dk/udgiv/publikationer/2003/87-7972-464-7/pdf/87-7972-465-5.pdf> (08-02-2021).

Danish Environmental Protection Agency (DEPA), 2003c: Waste Statistics 2001. Available at: <http://mst.dk/service/publikationer/publikationsarkiv/2003/mar/affaldsstatistik-2001/> (07/02-2021).

Danish Environmental Protection Agency (DEPA), 2003d: Waste Statistics 2002. Available at: <http://mst.dk/service/publikationer/publikationsarkiv/2003/jul/affaldsstatistik-2002/> (07/02-2021).

Danish Environmental Protection Agency (DEPA), 2004a: Point Sources 2003. In Danish: Punktkilder 2003. Orientering fra Miljøstyrelsen. nr. 16. Available at: <http://www2.mst.dk/Udgiv/publikationer/2004/87-7614-482-8/pdf/87-7614-483-6.pdf> (07/02-2021).

Danish Environmental Protection Agency (DEPA), 2004b: Waste Statistics 2003. Available at: <http://mst.dk/service/publikationer/publikationsarkiv/2004/nov/affaldsstatistik-2003/> (07/02-2021).

Danish Environmental Protection Agency (DEPA), 2005a: Point Sources 2004. In Danish: Punktkilder 2004. Orientering fra Miljøstyrelsen. nr. 9. Available at: <http://www2.mst.dk/Udgiv/publikationer/2005/87-7614-865-3/pdf/87-7614-866-1.pdf> (07/02-2021).

Danish Environmental Protection Agency (DEPA), 2005b: Point Sources 2003. Revision. In Danish: Punktkilder 2003 – revideret udgave. Orientering fra Miljøstyrelsen. nr. 1. Available at: <http://www2.mst.dk/Udgiv/publikationer/2005/87-7614-512-3/pdf/87-7614-513-1.pdf> (07/02-2021).

Danish Environmental Protection Agency (DEPA), 2005c: Waste Statistics 2004. Available at: <http://mst.dk/service/publikationer/publikationsarkiv/2005/okt/affaldsstatistik-2004/> (07/02-2021).

Danish Environmental Protection Agency (DEPA), 2006a: Affaldsstatistik 2005 (Waste Statistics 2005). Orientering fra Miljøstyrelsen nr. 6. Available at: <http://mst.dk/service/publikationer/publikationsarkiv/2006/okt/affaldsstatistik-2005/> (07/02-2021).

Danish Environmental Protection Agency (DEPA), 2006b: Legislation on sludge. Bekendtgørelse om anvendelse af affald til jordbrugsformål (Slambekendtgørelsen). BEK nr. 1650 af 13/12/2006. Available at: <https://www.retsinformation.dk/Forms/R0710.aspx?id=13056> (07/02-2021).

Danish Environmental Protection Agency (DEPA), 2008: Affaldsstatistik 2006. (Waste Statistics 2006) Orientering fra Miljøstyrelsen nr. 2 2008. Available at:

<http://www2.mst.dk/udgiv/publikationer/2008/978-87-7052-753-8/pdf/978-87-7052-754-5.pdf> (07/02-2021).

Danish Environmental Protection Agency (DEPA), 2010a: Affaldsstatistik 2007 og 2008. (Waste Statistics 2007 and 2008). Available at:

<http://mst.dk/media/mst/70152/Affaldsstatistik%202007%20og%202008.pdf> (07/02-2021).

Danish Environmental Protection Agency (DEPA), 2010b: Anvendelse af affald til jordbrugsformål. Vejledning fra Miljøstyrelsen Nr. 1 2010. Available at: <http://mst.dk/service/publikationer/publikationsarkiv/2010/avg/anvendelse-af-affald-til-jordbrugsformaal/> (07/02-2021).

Danish Environmental Protection Agency (DEPA), 2011a: Affaldsstatistik 2009 og fremskrivning af affaldsmængder 2011-2050. (Waste Statistics 2009). Available at: <http://www2.mst.dk/udgiv/publikationer/2011/10/978-87-92779-44-1/978-87-92779-44-1.pdf> (07/02-2021).

Danish Environmental Protection Agency (DEPA), 2011b: Legislation on waste (Affaldsbekendtgørelsen). BEK nr. 1415 af 12/12/2011 Gældende. Chapter 7. §46 and §47. Available at:

<https://www.retsinformation.dk/forms/r0710.aspx?id=139654#Kap7> (07/02-2021) (In Danish).

Danish Environmental Protection Agency (DEPA), 2013a: Affaldsstatistik 2011, (Waste Statistics 2011). Available at: <https://mst.dk/media/mst/Attachments/Affaldsstatistik2012.pdf> ((02/01-2021).

Danish Environmental Protection Agency (DEPA), 2013b: Livscyklusvurdering og samfundsøkonomisk analyse for anvendelse af spildevandsslam (Life cycle assessment and socioeconomic analysis of the use of sewage sludge), Miljøprojekt nr. 1459. Available at:

<https://www2.mst.dk/Udgiv/publikationer/2013/01/978-87-92903-81-5.pdf> (02/01-2021).

Danish Environmental Protection Agency (DEPA), 2013c: Innovationspartnerskab for anvendelse af fosfor fra spildevand og spildevandsslam fra spildevandsforsyninger Miljøprojekt nr. 1460. Available at:

<https://www2.mst.dk/Udgiv/publikationer/2013/01/978-87-92903-82-2.pdf> (02/01-2021).

Danish Environmental Protection Agency (DEPA), 2013d. Notat. Klimaplan Krav om og tilskud til biocover på visse lossepladser. Available at:

https://mst.dk/media/93663/ens_krav-om-og-tilskud-til-biocover-paa-visse-lossepladser.pdf (08-02-2021).

Danish Environmental Protection Agency (DEPA), 2014: Affaldsstatistik 2012, (Waste Statistics 2012). Available at:

<http://mst.dk/media/93643/affaldsstatistikken-2012.pdf> (07/02-2021).

Danish Environmental Protection Agency (DEPA), 2015: Affaldsstatistik 2013, (Waste Statistics 2013). Available at: <https://mst.dk/media/93478/affaldsstatistik-2013.pdf> (07/02-2021).

Danish Environmental Protection Agency (DEPA), 2016: Affaldsstatistik 2014, (Waste Statistics 2014). Available at: <https://www2.mst.dk/Udgiv/publikationer/2016/09/978-87-93529-05-2.pdf> (07/02-2021).

Danish Environmental Protection Agency (DEPA), 2017: Affaldsstatistik 2015, (Waste Statistics 2015). Available at: <https://www2.mst.dk/Udgiv/publikationer/2017/05/978-87-93614-01-7.pdf> (07/02-2021).

Danish Environmental Protection Agency (DEPA), 2018a. Affaldsstatistik 2016, (Waste Statistics 2016). Available at: <https://www2.mst.dk/Udgiv/publikationer/2018/06/978-87-93710-39-9.pdf> (07/02-2021).

Danish Environmental Protection Agency (DEPA), 2018b: Point sources 2016. In Danish: Punktkilder 2016. Det nationale program for overvågning af vandmiljøet, Fagdatacenterreport. Available at: <https://mst.dk/service/publikationer/publikationsarkiv/2018/apr/punktkilder-2016/> (07/02-2021).

Danish Environmental Protection Agency (DEPA), 2019a Affaldsstatistik 2017, (Waste Statistics 2017). Available at: <https://mst.dk/service/publikationer/publikationsarkiv/2019/sep/affaldsstatistik-2017/> (07/02-2021).

Danish Environmental Protection Agency (DEPA), 2019b: Point sources 2017. In Danish: Punktkilder 2016. Det nationale program for overvågning af vandmiljøet, Fagdatacenterreport. Available at: <https://www2.mst.dk/Udgiv/publikationer/2019/02/978-87-7038-042-3.pdf/> (07/02-2021).

Danish Environmental Protection Agency (DEPA), 2019c: Point sources 2018. In Danish: Punktkilder 2016. Det nationale program for overvågning af vandmiljøet, Fagdatacenterreport. Available at: <https://mst.dk/service/publikationer/publikationsarkiv/2019/dec/punktkilder-2018/> (07/02-2021).

Danish Environmental Protection Agency (DEPA), 2020a Affaldsstatistik 2018, (Waste Statistics 2018). Available at: <https://www2.mst.dk/Udgiv/publikationer/2020/05/978-87-7038-183-3.pdf> (04/01-2021).

Danish Environmental Protection Agency (DEPA), 2020b Affaldsstatistik 2019, (Waste Statistics 2019). Available at: <https://www2.mst.dk/Udgiv/publikationer/2020/12/978-87-7038-249-6.pdf> (04/01-2021).

Danish Environmental Protection Agency (DEPA) 2020c. MUDP lattergas-pulje. Dataopsamling på måling og reduktion af lattergas emissioner fra renseanlæg (Data collection on measurement and reduction of nitrous oxide emissions from WWTPs) ISBN: 978-87-7038-254-0. Available at: <https://www2.mst.dk/Udgiv/publikationer/2020/12/978-87-7038-254-0.pdf> (08-02-2021)

Danish Gas Technology Center (DGC), 2009: DGC målerapport 731-28-5 November 2009. Gasmotoranlæg. Jenbacher J 316. deponigas. Steen D. Andersen. Available at: https://www.dgc.dk/sites/default/files/filer/publikationer/Report_Site5.pdf (07/02-2021).

Danish Nature Agency (DNA), 2007: Point sources 2006. In Danish: Punktkilder 2006. Det nationale program for overvågning af vandmiljøet, Fagdata-centerrapport. Available at: <http://www2.blst.dk/udgiv/Publikationer/2007/978-87-92256-36-2/pdf/978-87-92256-37-9.pdf> (07/02-2021).

Danish Nature Agency (DNA), 2009: Point sources 2007. In Danish: Punktkilder 2007. Det nationale program for overvågning af vandmiljøet, Fagdata-centerrapport. Available at: http://naturstyrelsen.dk/media/nst/70162/Punktkilderrapport_.pdf (07/02-2021).

Danish Nature Agency (DNA), 2010a: Point sources 2008. In Danish: Punktkilder 2008. Det nationale program for overvågning af vandmiljøet, Fagdata-centerrapport. Available at: <http://naturstyrelsen.dk/media/nst/70006/PunktkildeRapport200815022010.pdf> (07/02-2021).

Danish Nature Agency (DNA), 2010b: Point sources 2009. In Danish: Punktkilder 2009. Det nationale program for overvågning af vandmiljøet, Fagdata-centerrapport. Available at: <http://naturstyrelsen.dk/publikationer/2011/jan/punktkilder-2009/> (07/02-2021).

Danish Nature Agency (DNA), 2011: Point sources 2010. In Danish: Punktkilder 2010. Det nationale program for overvågning af vandmiljøet, Fagdata-centerrapport. Available at: <http://naturstyrelsen.dk/media/nst/66770/Punktkilder%202010.pdf> (07/02-2021).

Danish Nature Agency (DNA), 2012: Point sources 2011. In Danish: Punktkilder 2011. Det nationale program for overvågning af vandmiljøet, Fagdata-centerrapport. Available at: <http://naturstyrelsen.dk/media/nst/66851/Punktkilderapport%202011.pdf> (07/02-2021).

Danish Nature Agency (DNA), 2013: Point sources 2012. In Danish: Punktkilder 2012. Det nationale program for overvågning af vandmiljøet, Fagdata-centerrapport. Available at: <http://naturstyrelsen.dk/publikationer/2013/dec/punktkilder-2012/> (07/02-2021).

Danish Nature Agency (DNA), 2015a: Point sources 2013. In Danish: Punktkilder 2013. Det nationale program for overvågning af vandmiljøet, Fagdata-centerrapport. Available at: <http://naturstyrelsen.dk/publikationer/2015/feb/punktkilder-2013/> (07/02-2021).

Danish Nature Agency (DNA), 2015b: Point sources 2014. In Danish: Punktkilder 2014. Det nationale program for overvågning af vandmiljøet, Fagdata-centerrapport. Available at: <http://naturstyrelsen.dk/media/175045/punktkilderrapport-2014.pdf> (07/02-2021).

Danish Nature Agency (DNA), 2017: Point sources 2015. In Danish: Punktkilder 2015. Det nationale program for overvågning af vandmiljøet, Fagdata-centerrapport. Available at: <http://mst.dk/media/114910/punktkilder-2015.pdf> (07/02-2021).

Danske Krematoriernes Landsforening (DKL), 2009: Røggasrensning, Miljøbehandling og varmeudnyttelse, Status juni 2009. Miljø- og Planlægningsudvalget, MPU alm. del - Svar på Spørgsmål 591. Available at: <https://www.ft.dk/samling/20081/alm-del/mpu/spm/591/svar/641398/714098.pdf> (02/02-2022).

Danske Krematoriernes Landsforening (DKL), 2021: Association of Danish crematories. statistisk materiale. Available at: <http://www.dkl.dk/> (02/02-2022).

DANVA, 2008: Eksplosiv atmosfære i kloakker (English title: Explosive atmosphere in sewers). Report no. 77. ISBN: 87-90455-79-7. Available at: https://www.danva.dk/media/2695/eksplosiv_atmosfaere_i_kloaker_samlet_rapport.pdf (07/02-2021).

DANVA, 2009: Håndtering af spildevandsslam Katalog over metoder til behandling og slutdisponering (English title: Management of waste water sludge. Catalog of methods for treatment and final disposal). Report no. 82. Available at: <https://www.danva.dk/media/2683/vejledning-nr-82-danva-slamkatalog.pdf> (02-01-2021).

DANVA, 2011: Køkkenkvarne: energi-, miljø- og driftsmæssige konsekvenser ved brug i boliger. Report no. 85. Available at: <https://www.danva.dk/media/2831/20110811-rapport-koekkenkvaernsrapport-lf.pdf> (07/02-2021).

Delre, A., Mønster J., Scheutz C., 2017: Greenhouse gas emission quantification from wastewater treatment plants, using a tracer gas dispersion method. *Science of the Total Environment*, 605–606, 258–268.

EC, 2009: REGULATION (EC) No 1069/2009 OF THE EUROPEAN PARLIAMENT AND OF THE COUNCIL of 21 October 2009. Available at: <https://eur-lex.europa.eu/LexUriServ/LexUriServ.do?uri=OJ:L:2009:300:0001:0033:EN:PDF> (02/02-2022).

European Environment Agency (EEA), 2009: The EMEP/EEA air pollutant emission inventory guidebook. Technical report No 9/2009. Available at: <http://www.eea.europa.eu/publications/emep-eea-emission-inventory-guidebook-2009> (07/02-2021).

European Environment Agency (EEA), 2016: The EMEP/EEA air pollutant emission inventory guidebook. Technical report No 21/2016. Available at: <https://www.eea.europa.eu/publications/emep-eea-guidebook-2016> (07/02-2021).

Executive order 650, 2001: Executive Order on landfills. (In Danish: Bekendtgørelse 650, 2001. Bekendtgørelse om deponeringsanlæg). Available at: <https://www.retsinformation.dk/eli/lta/2001/650> (07/02-2021).

Executive Order No. 752 of 21/06/2016. Executive Order on grants to establish biocover at landfills and landfills. Available at: <https://www.retsinformation.dk/Forms/R0710.aspx?id=180307> (07/02-2021).

Fausser, P., Thomsen, M., Nielsen, O., Winther, M., Gyldenkerne, S., Hoffmann, L., Lyck, E. & Illerup, J.B., 2007: Verification of the Danish emission inventory data by national and international data comparisons. Danmarks Miljøundersøgelser. Aarhus University. 53 pp - NERI Technical Report No. 627. Available at: http://www2.dmu.dk/Pub/FR627_Final.pdf (07/02-2021).

Fausser, P., Sørensen, P.B., Nielsen, M., Winther, M., Plejdrup, M.S., Hoffmann, L., Gyldenkerne, S., Mikkelsen, M.H., Albrektsen, R., Lyck, E., Thomsen, M., Hjelgaard, K. & Nielsen, O-K., 2011: Monte Carlo (Tier 2) Uncertainty Analysis of Danish Greenhouse Gas Emission Inventory. Greenhouse Gas Measurement & Management. 1(3/4). 145-161. Available at: doi.org/10.1080/20430779.2011.621949 (07/02-2021).

Fausser, P., Nielsen, M., Winther, M., Plejdrup, M. S., Gyldenkerne, S., Mikkelsen, M.H., Albrektsen, R., Hoffmann, L., Thomsen, M., Hjelgaard, K. & Nielsen, O-K., 2013: Verification of the Danish GHG Key Categories and Annex II Indicators. Greenhouse Gas Measurement & Management 3(3-4). 107-127. Available at: doi.org/10.1080/20430779.2013.870022 (07/02-2021).

Friedrich, H., Fehrenbach, H., Giegrich, J. & Knappe, F. 2002: Abfallrelevanz der Klärschlammbehandlung in NRW, Müll und Abfall 9. Available at: <https://doi.org/10.37307/j.1863-9763.2002.09.02> (07/02-2021).

Gejlsbjerg, B., Frette, L. & Westermann, P. 1999: N₂O release from active sludge, water and soil. In Danish: Lattergasfrigivelse fra aktiv-slam, Vand & Jord, 1, pp. 33-37. Available at: <http://www.vand-og-jord.dk/tidligere.htm> (07/02-2021).

GEUS (Geological Survey of Denmark and Greenland), 2020a: Muligheder og udfordringer for landfill mining i Danmark. MiMa rapport 2020/1. Available at: http://mima.geus.dk/wp-content/uploads/MiMa_rapport_2020-1-Muligheder-og-udfordringer-for-landfill-mining-i-Danmark.pdf (09-02-2021).

GEUS (Geological Survey of Denmark and Greenland), 2020b: Muligheder og udfordringer for landfill mining i Danmark. MiMa rapport 2020/2. Available at: <http://mima.geus.dk/wp-content/uploads/Muligheder-og-udfordringer-for-landfill-mining-i-Danmark-2020.pdf> (09-02-2021).

Glæsner, N., Lemming, C., Magid, J., Jensen, L.S., 2016: Review af eksisterende viden om plantetilgængelighed af fosfor i forskellige slamprodukter. Institut for plante og Miljøvidenskab, Københavns Universitet. Available at:

https://plen.ku.dk/raadgivning/rapporter/Rapport_for_projekt_om_P_tilg_angelighed_20-05-2016.pdf (02/01-2021).

Gudmundsson, E., Fredenslund, A., Falk, J. M., Scheutz, C., Mønster J., Hinge, J. & Petersen, S.: Måltrettet indsats for at mindske metantab fra danske biogasanlæg. Rapport til Energistyrelsen. August 2021. Available at: https://ens.dk/sites/ens.dk/files/Bioenergi/metantab_rapport.pdf (08-02-2022) (In Danish).

Hjelgaard, K., 2013: Danish Emission Inventory for Waste Incineration and Other Waste. Inventories until year 2011. Aarhus University. DCE – Danish Centre for Environment and Energy. 96 pp. Scientific Report from DCE – Danish Centre for Environment and Energy No. 70. Available at: <http://dce.au.dk/udgivelser/vr/nr-51-100/abstracts/no-70-danish-emission-inventory-for-waste-incineration-and-other-waste/> (08/02-2021).

Hvitved-Jacobsen, T., 2001: Sewer Processes – Microbial and Chemical Process Engineering of Sewer Networks. CRC Press. Available at: <https://www.crcpress.com/Sewer-Processes-Microbial-and-Chemical-Process-Engineering-of-Sewer-Networks/Hvitved-Jacobsen-Vollertsen-Nielsen/p/book/9781439881774> (08/02-2021).

Intergovernmental Panel on Climate Change (IPCC), 2000: Good Practice Guidance and Uncertainty Management in National Greenhouse Gas Inventories. Available at: <http://www.ipcc-nggip.iges.or.jp/public/gp/english/index.html> (08/02-2021).

Intergovernmental Panel on Climate Change (IPCC), 2006: 2006 IPCC Guidelines for National Greenhouse Gas Inventories. Available at: <http://www.ipcc-nggip.iges.or.jp/public/2006gl/index.html> (08/02-2021).

ISAG: The Danish Environmental Protection Agency. Database on all registered Danish waste. Available at: <http://mst.dk/affald-jord/affald/affalddatasystemet/find-affalldsdata/isag-udtraek/> (08/02-2021).

Jensen, T.C. & Kveiborg, O. 2013: Dokumentation af konvertering af trafikalt til emissionsopgørelser. Arbejdsnotat. DTU Transport. 2013.

Jensen, MD, Tychsen, P, Thomsen, M, Martinsen, L & Hasler, B 2015: Bæredygtig udnyttelse af fosfor fra spildevand. Miljøprojekt 1661, ISBN nr. 978-87-93283-94-7. Available at: <https://www2.mst.dk/Udgiv/publikationer/2015/03/978-87-93283-94-7.pdf> (08/02-2021).

[Kampschreur](#), M.J., Temmink, H., Kleerebezem, R., Jetten, M.S.M. & van Loosdrecht, M.C.M., 2009: Nitrous oxide emission during wastewater treatment. *Water Research* 43. 4093-4103. DOI: 10.1016/j.watres.2009.03.001. Available at:

<https://www.sciencedirect.com/science/article/pii/S0043135409001420?via%3Dihub> (08/02-2021).

Kirkeby, J.T., Gabriel, S., & Christensen, T.H. 2005: Miljøvurdering af genanvendelse og slutdisponering af spildevandsslam: en livscyklus screening af fire scenarier. Institut for Miljø & Ressourcer, Danmarks Tekniske Universitet i samarbejde med Hedeselskabet, Århus og Fredericia Kommuner. Available at:

<https://orbit.dtu.dk/en/publications/milj%C3%B8vurdering-af-genanvendelse-og-slutdisponering-af-spildevands> (08/02-2021).

Kjeldsen, P., Scheutz, C., 2016: Etablering og monitorering af biocoversystemer på affaldsdeponeringsanlæg Vidensopsamling (English title: Establishment and monitoring of biocover systems on landfill - knowledge collection). DEPA Environmental project 1817. ISBN nr. 978-87-93435-14-8. Available at:

<https://www2.mst.dk/Udgiv/publikationer/2016/03/978-87-93435-14-8.pdf> (08/02-2021).

Kristensen, G.H. & Jørgensen, P.E., 2008: Renseteknik – oversigt over ny miljøteknologi indenfor spildevandshåndtering (English title: Wastewater treatment Technologies - Overview of new environmental technology in waste water management). ASEP report. Available at:

<http://www2.blst.dk/udgiv/publikationer/2008/978-87-92256-39-3/pdf/978-87-92256-40-9.pdf> (08/02-2021).

Landfill Directive, 1999: COUNCIL DIRECTIVE 1999/31/EC of 26 April 1999 on the landfill of waste. Available at:

<https://eur-lex.europa.eu/LexUriServ/LexUriServ.do?uri=CONSLEG:1999L0031:20081211:ENG:PDF> (08-02-2021).

Lyngby-Taarbæk Kommune, 2014: Midlertidig tilslutningstilladelse til udledning af byggegrubevand fra bygge- og anlægsarbejdet på Kanalvej 7 (English title: Temporary connection permit for the discharge of water in relation to the construction work on Kanalvej 7). Available at:

http://www.ltk.dk/sites/default/files/uploads/public/user_uploads/CMP/Hoeringer/tilslutningstilladelse.pdf (08/02-2021).

Lönnermark, A. & Blomqvist, P., 2006: Emissions from an automobile fire. *Chemosphere* 62 (2006) 1043–1056. Available at:

<http://www.sciencedirect.com/science/article/pii/S0045653505006351> (03/02-2022).

MILIKI, 2006: Ministeriet for Ligestilling og Kirke (Ministry for Gender Equality and Ecclesiastical Affairs). Rapport fra arbejdsgruppe vedrørende krematorievirksomhed i Danmark. December 2006. Available at:

http://www.km.dk/fileadmin/share/publikationer/Krematorier/Rapport_om_krematorier.pdf (02/02-2021).

Ministry of Environment and Food of Denmark, 2011: Statutory order for Landfilling. No. 719.24/06/2011 (Deponeringsbekendtgørelsen). Available

at: <https://www.retsinformation.dk/forms/R0710.aspx?id=137791>
(08/02-2021).

Ministry of Environment and Food of Denmark, 2012: Statutory order for Waste. No. 1309 af 18/12/2012 (Affaldsbekendtgørelsen). Available at: <https://www.retsinformation.dk/Forms/R0710.aspx?id=144826>
(08/02-2021).

MST, 2013: Livscyklusvurdering og samfundsøkonomisk analyse for anvendelse af spildevandsslam. Miljøministeriet. Miljøstyrelsen (MST). Miljøprojekt nr. 1459. 2013. ISBN nr. 978-87-92903-81-5. Available at: <https://www2.mst.dk/Udgiv/publikationer/2013/01/978-87-92903-81-5.pdf> (08/02-2021).

Morvay, Z.K. & Gvozdenac, D.D., 2009: Applied Industrial Energy and Environmental Management. John Wiley & Sons, Ltd. Online ISBN: 9780470714379. DOI: 10.1002/9780470714379. Available at: <https://onlinelibrary.wiley.com/doi/book/10.1002/9780470714379>
(08/02-2021).

Mønster, J., Samuelsson, J., Kjeldsen, P. & Scheutz, C., 2015: Quantification of methane emissions from 15 Danish landfills using the mobile tracer dispersion method. Waste Management 35, 177-186. Available at: doi.org/10.1016/j.wasman.2014.09.006. (08/02-2021).

National Atmospheric Emission Inventory of UK (NAEI), 2009: Available at: <https://naei.beis.gov.uk/> (02/02-2022).

Nielsen, O.-K., Plejdrup, M.S., Winther, M., Nielsen, M., Gyldenkerne, S., Mikkelsen, M.H., Albrektsen, R., Thomsen, M., Hjelgaard, K., Fauser, P., Bruun, H.G., Johannsen, V.K., Nord-Larsen, T., Vesterdal, L., Callesen, I., Caspersen, O.H., Scott-Bentsen, N., Rasmussen, E., Petersen, S.B., Olsen, T. M. & Hansen, M.G., 2019. Denmark's National Inventory Report 2019. Emission Inventories 1990-2017 - Submitted under the United Nations Framework Convention on Climate Change and the Kyoto Protocol. Aarhus University, DCE - Danish Centre for Environment and Energy, 886 pp. Scientific Report No. 318. Available at: <http://dce2.au.dk/pub/SR318.pdf>
(08/02-2021).

Nielsen, A.H., Vollertsen, J., Højmark J., Simon, M. & Rudelle, E.A., 2018: Hybridfilter for fjernelse af lugt- og drivhusgasser fra septiktanke og iltfri spildevandsnet. Publisher: Danish EPA. ISBN: 978-87-93710-18-4. Available at: <https://www2.mst.dk/Udgiv/publikationer/2018/05/978-87-93710-18-4.pdf> (08/02-2021).

Nissen, E.L., 2017a: Expert judgement, Composting in Denmark, DEPA, personal communication.

Nissen, E.L., 2017b: Expert judgement, Number of active landfills in Denmark, DEPA, personal communication.

Pedersen, R.B., Scheutz, C. & Kjeldsen, P., 2012: Reduktion af metanemissionen fra Klintholm losseplads ved etablering af Biocover. Environmental Project report no. 1401, Ministry of Environment. Available at: <http://www2.mst.dk/Udgiv/publikationer/2012/03/978-87-92779-77-9.pdf> (08/02-2021).

Petersen, C., 2001: Statistik for behandling af organisk affald fra husholdninger – Revideret udgave (Statistics for treatment of organic waste from households – revised version). Miljøprojekt Nr. 654 2001. Miljøstyrelsen. Miljøministeriet. Available at: <http://www2.mst.dk/Udgiv/publikationer/2001/87-7944-932-8/pdf/87-7944-933-6.pdf> (08/02-2021).

Petersen, C. & Hansen, V.L., 2003: Statistik for behandling af organisk affald fra husholdninger 2001 (Statistics for treatment of organic waste from households). Miljøprojekt Nr. 856 2003. Miljøstyrelsen. Miljøministeriet. Available at: <http://www2.mst.dk/Udgiv/publikationer/2003/87-7972-962-2/pdf/87-7972-963-0.pdf> (08/02-2021).

Petersen, C. & Kielland, M., 2003: Statistik for hjemmekompostering (Statistics on home composting). Econet A/S. Miljøprojekt Nr. 855 2003. Miljøstyrelsen. Miljøministeriet. Available at: <http://www2.mst.dk/udgiv/publikationer/2003/87-7972-960-6/pdf/87-7972-961-4.pdf> (08/02-2021).

Schleicher, O. & Gram, L.K., 2008: Miljøprojekt Nr. 1191. Analyse af omkostningerne for rensning for kviksølv på krematorier i Danmark. Miljøministeriet. Miljøstyrelsen. Available at: <https://www2.mst.dk/udgiv/publikationer/2008/978-87-7052-594-7/html/default.htm> (08/02-2021).

Schleicher, O., Jensen, A.A. & Blinksbjerg, P., 2001: Miljøprojekt Nr. 649. Måling af dioxinemissionen fra udvalgte sekundære kilder. Miljøministeriet. Miljøstyrelsen. Available at: <http://www2.mst.dk/Udgiv/publikationer/2001/87-7944-868-2/pdf/87-7944-869-0.pdf> (08/02-2021).

Statistics Denmark, 2021: StatBank Denmark. Available at: <http://www.statistikbanken.dk/statbank5a/default.asp?w=1024> (02/02-2022).

Tafdrup, S., 2014: Expert Judgement of the gross energy production. Søren Tafdrup, Consultant, Danish Energy Agency. Personal communication.

The Danish Government, 1999: Waste 21. Waste Management plan 1998-2004. Available at: <http://www2.mst.dk/Udgiv/publications/1999/87-7909-571-2/pdf/87-7909-570-4.pdf> (08/02-2021).

The Danish Government, 2003: Affaldsstrategi 2005-2008. (In Danish: Waste Strategy 2005-2008. Available at: <http://www2.mst.dk/Udgiv/publikationer/2003/87-7972-971-1/pdf/87-7972-973-8.pdf> (08/02-2021).

The Danish Government, 2009: Affaldsstrategi 2009-2012 1. delstrategi. (In Danish: Waste Strategy 2009-2012. Available at: <http://mst.dk/media/mst/69997/Endelig%201%20%20del%20af%20Affaldsstrategi%202009-12.pdf> (08/02-2021).

The Danish Government, 2010: (Waste Strategy 2009-2012. Part II) Available at: http://eng.mst.dk/media/164923/denmark-without-waste-ii_wasteprevention.pdf (08/02-2021).

The Danish Government, 2013: Denmark without waste. Recycle more – incinerate less. Available at: http://mfvm.dk/fileadmin/user_upload/MFVM/Miljoe/Ressourcestrategi_UK_web.pdf (08/02-2021).

Thomsen, M., With Ottosen, T. & Nyrup Drejer, L., 2015: Analyse af potentialer for ressourceudnyttelse i vand- og spildevandsforsyningen. Naturstyrelsen, Miljøministeriet, 2015. 85 s. Available at: <http://ecoinnovation.dk/media/130961/analyse-af-potentialer-for-ressourceudnyttelse-i-vand-og-spildevandsforsyningen.pdf> (08/02-2021).

Thomsen, M., 2016. Wastewater treatment and discharge. Aarhus University, DCE – Danish Centre for Environment and Energy, 79 pp. Scientific Report from DCE – Danish Centre for Environment and Energy No. 193. Available at: <http://dce2.au.dk/pub/SR193.pdf> (08/02-2021).

Vattenfall, 2010: Fynsværket CO₂-udledningsrapport 2010.

Verdo, 2011: Verdo (Randers) CO₂-kvote indberetning 2011.

Vollertsen, J., Vorkamp, K., Hvitved-Jacobsen, T. & Jensen, N.A., 2002: Ud-sivning af spildevand fra afløbssystemer. Miljøprojekt Nr. 685. Available at: <https://www2.mst.dk/udgiv/publikationer/2002/87-7972-084-6/html/helepubl.htm> (08/02-2021).

Vollertsen, J., 2012: Expert judgement of the $MCF_{sewer+MB}$. Jes Vollertsen, PhD, Professor of Environmental Engineering. Personal communication.

Vollertsen, J., 2018: Expert judgement of the MCF_{st} and EF_{st} . Jes Vollertsen, PhD, Professor of Environmental Engineering. Personal communication.

Wicht, H. & Beier, M., 1995: N₂O emission aus nitrifizierenden und denitrifizierenden Kläranlagen. Korrespondenz Abwasser 42, 404–406. Available at: <https://www.tib.eu/de/suchen/id/olc%3A1745053824/N20-Emissionen-aus-nitrifizierenden-und-denitrifizierenden/> (08/02-2021).

Zeng, Y., De Guardia, A. & Dabert, P., 2016: Improving composting as a post-treatment of anaerobic digestate. Bioresource Technology 201 (2016) 293–303. Available at: <http://dx.doi.org/10.1016/j.biortech.2015.11.013> (02/01-2021).

8 Other

In CRF Sector 6, there are no activities and emissions for the inventories of Denmark.

9 Recalculations and improvements

Explanations for the recalculations of the Danish inventory are included in the sectoral chapters of the NIR.

The overall impact of recalculations is shown in Table 9.1. A more detailed overview is provided in Tables 9.2 – 9.5.

Information on recalculations for the aggregated submission of Denmark and Greenland are included in Chapter 17.

9.1 Explanations and justifications for recalculations

Explanations and justifications for the recalculations performed in this submission, since the previous submission of data to the UNFCCC for Denmark, are given in the individual sector chapters.

9.2 Implications for emission levels

For the national total CO₂ equivalent emissions without Land-Use, Land-Use Change and Forestry, the general impact of the improvements and recalculations performed is small and the changes for the whole time-series are between 0.30 % (1994 & 1996) and 0.67 % (2014, 2015 & 2017). The implications of the recalculations on the level and on the trend, 1990-2019, of the national total are very small, see Table 9.1.

For the national total CO₂ equivalent emissions with Land-Use, Land-Use Change and Forestry, the general impact of the recalculations is larger due to recalculations in the LULUCF sector, see Table 9.1 and explanations in Chapter 6.

Table 9.1 Recalculation performed in the 2022 submission for 1990-2019. Differences in pct. of CO₂ equivalents between this submission and the April 2021 submission for Denmark, excluding Greenland and the Faroe Islands.

Year	1990	1991	1992	1993	1994	1995	1996	1997	1998	1999	2000
Total CO ₂ eqv. Emissions with Land-Use Change and Forestry	0.83	1.19	1.15	0.93	1.07	1.19	0.99	1.24	1.42	1.63	1.12
Total CO ₂ eqv. Emissions without Land-Use Change and Forestry	0.38	0.32	0.31	0.34	0.29	0.35	0.29	0.36	0.37	0.36	0.41
	2001	2002	2003	2004	2005	2006	2007	2008	2009	2010	2011
Total CO ₂ eqv. Emissions with Land-Use Change and Forestry	1.63	1.61	1.40	1.47	1.46	1.02	0.85	0.90	1.21	1.10	0.91
Total CO ₂ eqv. Emissions without Land-Use Change and Forestry	0.40	0.40	0.39	0.40	0.42	0.44	0.42	0.44	0.49	0.45	0.50
	2012	2013	2014	2015	2016	2017	2018	2019			
Total CO ₂ eqv. Emissions with Land-Use Change and Forestry	1.32	1.11	1.26	1.00	0.93	0.97	1.06	1.61			
Total CO ₂ eqv. Emissions without Land-Use Change and Forestry	0.54	0.53	0.67	0.66	0.65	0.67	0.59	0.60			

9.3 Implications for emission trends, including time series consistency

It is a high general priority in the considerations leading to recalculations back to 1990 to have and preserve the consistency of the activity data and emissions time-series. As a consequence activity data, emission factors and methodologies are carefully chosen to represent the emissions for the time-series correctly. Often considerations regarding the consistency of the time-series have led to recalculations for single years when activity data and/or emission factors have been changed or corrected. Furthermore, when new sources are considered, activity data and emissions are as far as possible introduced to the inventories for the whole time-series based on preferably the same methodology.

The implication of the recalculations is further shown in Tables 9.2-9.5.

Table 9.2 Recalculation for CO₂ performed in the 2022 submission for 1990-2019. Differences in kt CO₂ equivalents between this and the April 2021 submission for Denmark. Excluding Greenland and Faroe Islands.

CO ₂ kt	1990	1991	1992	1993	1994	1995	1996	1997	1998	1999	2000	2001	2002	2003	2004
Total National Emissions and Removals	376	773	702	516	684	718	691	793	890	1041	566	966	955	856	841
1. Energy	17	17	16	16	13	17	18	20	19	16	16	17	16	18	23
1.A. Fuel Combustion Activities	17	17	16	16	17	18	19	20	20	17	16	17	17	19	23
1.A.1. Energy Industries	5	5	6	6	7	21	9	13	15	19	27	26	27	26	26
1.A.2. Manufacturing Industries and Construction	149	141	105	96	66	74	38	31	-1	-11	-39	-43	-54	-68	-60
1.A.3. Transport	17	17	16	16	15	15	16	18	17	15	-13	-11	-12	-6	-3
1.A.4. Other Sectors	-154	-146	-111	-101	-72	-93	-45	-42	-12	-6	41	45	55	66	59
1.A.5. Other	0	0	0	0	0	0	0	0	0	0	0	0	0	0	0
1.B. Fugitive Emissions from Fuels	0	0	0	0	-3	0	0	0	0	-1	0	-1	0	0	-1
2. Industrial Processes and product use	0	0	0	0	-1	-2	0	-1	1	1	-1	1	0	1	1
2.A. Mineral industry	-1	-1	-1	-1	-1	-2	0	-1	0	0	0	0	-1	1	1
2.B. Chemical industry	-	-	-	-	-	-	-	-	-	-	-	-	-	-	-
2.C. Metal industry	-	-	-	-	-	-	-	-	-	-	-	-	-	-	-
2.D. Non-energy products from fuels and solvent use	0	0	0	0	0	0	0	0	0	1	-1	1	0	0	1
2.G. Other product manufacture and use	-	-	-	-	-	-	-	-	-	-	-	-	-	-	-
3. Agriculture	-5	-5	-4	-4	-4	-3	-2	-1	-1	-1	-1	-1	0	0	0
3. G. Liming	-	-	-	-	-	-	-	-	-	-	-	-	-	-	-
3.H. Urea application	-	-	-	-	-	-	-	-	-	-	-	-	-	-	-
3.I. Other carbon-containing fertilizers	-5	-5	-4	-4	-4	-3	-2	-1	-1	-1	-1	-1	0	0	0
4. Land Use, Land-Use Change and Forestry (net)	365	762	691	504	674	705	675	775	871	1024	551	948	939	837	817
4.A. Forest Land	23	29	33	37	39	34	29	24	18	13	-123	28	-17	-59	-98
4.B. Cropland	348	366	358	352	400	403	401	465	412	415	370	401	347	355	357
4.C. Grassland	0	0	0	0	0	0	0	0	0	0	0	0	0	0	0
4.D. Wetlands	-6	-6	-6	-6	-6	-6	-6	-6	-6	-6	-6	-6	-6	-6	-6
4.E. Settlements	0	0	0	0	0	0	0	0	0	0	0	0	0	0	-12
4.F. Other Land															
4.G. Harvested wood products	0	373	306	121	241	275	251	293	447	602	310	526	615	547	576
5. Waste	0	0	0	0	0	0	0	0	0	0	0	0	0	0	0
5.E. Other	0	0	0	0	0	0	0	0	0	0	0	0	0	0	0
	2005	2006	2007	2008	2009	2010	2011	2012	2013	2014	2015	2016	2017	2018	2019
Total National Emissions and Removals	776	534	395	367	520	461	323	457	352	352	193	178	198	315	537
1. Energy	27	58	53	36	35	34	33	31	27	35	26	22	38	53	57
1.A. Fuel Combustion Activities	28	59	53	36	35	34	33	31	27	34	26	23	37	53	57
1.A.1. Energy Industries	45	23	21	19	23	34	27	23	48	66	25	30	46	61	60

<i>Continued</i>	2005	2006	2007	2008	2009	2010	2011	2012	2013	2014	2015	2016	2017	2018	2019
1.A.2. Manufacturing Industries and Construction	-60	-54	-62	-68	-49	-40	-76	-48	-75	-78	-57	-45	-65	-29	-26
1.A.3. Transport	0	0	8	5	2	7	3	2	-15	-24	-5	-12	-2	-18	-21
1.A.4. Other Sectors	42	91	86	79	59	33	80	54	69	71	62	49	57	39	43
1.A.5. Other	0	0	0	0	0	0	0	0	0	0	0	0	0	0	0
1.B. Fugitive Emissions from Fuels	0	0	0	0	0	0	0	0	0	0	0	0	1	0	0
2. Industrial Processes and product use	1	1	1	0	0	0	0	0	0	0	0	0	0	0	2
2.A. Mineral industry	-	-	-	-	-	-	-	-	-	-	-	-	-	-	0
2.B. Chemical industry	-	-	-	-	-	-	-	-	-	-	-	-	-	-	0
2.C. Metal industry	-	-	-	-	-	-	-	-	-	-	-	-	-	-	-
2.D. Non-energy products from fuels and solvent use	1	1	1	0	0	0	0	0	0	0	0	0	0	0	2
2.G. Other product manufacture and use	-	-	-	-	-	-	-	-	-	-	-	-	-	0	0
3. Agriculture	0	0	0	0	0	0	0	0	0	0	-1	0	0	0	-1
3. G. Liming	-	-	-	-	-	-	-	-	-	-	-	-	-	-	-
3.H. Urea application	-	-	-	-	-	-	-	-	-	-	-	-	-	-	0
3.I. Other carbon-containing fertilizers	0	0	0	0	0	0	0	0	0	0	-1	0	0	0	-1
4. Land Use, Land-Use Change and Forestry (net)	748	475	341	331	485	428	290	426	324	318	169	156	161	262	479
4.A. Forest Land	39	-128	-85	-44	-4	35	65	67	54	54	51	58	55	65	63
4.B. Cropland	381	401	298	351	399	382	375	295	284	313	296	252	262	127	176
4.C. Grassland	0	0	0	0	0	0	0	0	0	0	0	-1	-1	-1	-1
4.D. Wetlands	-161	-161	-161	-161	-161	-161	-161	-	-	-16	-3	-36	-	-16	-
4.E. Settlements	0	0	0	0	0	-	-38	36	-20	27	-32	23	13	3	-9
4.F. Other Land															
4.G. Harvested wood products	489	363	289	184	251	171	49	29	6	-60	-143	-140	-169	84	250
5. Waste	0	0	-	-	-	-	-	-	0	0	0	0	0	0	0
5.E. Other	0	0	-	-	-	-	-	-	0	0	0	0	0	0	0

Table 9.3 Recalculation for CH₄ performed in the 2022 submission for 1990-2019. Differences in kt CO₂ equivalents between this and the April 2021 submission for Denmark. Excluding Greenland and Faroe Islands.

CH ₄ , kt CO ₂ equivalents	1990	1991	1992	1993	1994	1995	1996	1997	1998	1999	2000	2001	2002	2003	2004
Total National Emissions and Removals	1	2	2	4	3	5	7	7	8	10	8	8	9	9	9
1. Energy	-1	-1	-1	-1	-1	0	0	0	0	0	0	0	0	0	-1
1.A. Fuel Combustion Activities	-1	-1	-1	0	0	0	0	0	0	0	0	0	0	-1	-1
1.A.1. Energy Industries	0	0	0	0	0	0	0	0	0	0	0	0	0	0	0
1.A.2. Manufacturing Industries and Construction	0	0	0	0	0	0	0	0	0	0	0	0	0	0	0
1.A.3. Transport	0	0	0	0	0	0	0	0	0	0	0	0	0	0	0
1.A.4. Other Sectors	-1	-1	0	0	0	0	0	0	0	0	0	0	0	0	0
1.A.5. Other	0	0	0	0	0	0	0	0	0	0	0	0	0	0	0
1.B. Fugitive Emissions from Fuels	0	0	0	0	0	0	0	0	0	0	0	0	0	0	0
2. Industrial Processes and product use	-	-	-	-	-	-	-	-	-	-	-	-	-	-	-
3. Agriculture	2	3	3	4	4	6	7	7	8	10	8	8	9	10	9
3.A. Enteric Fermentation	0	0	0	0	0	0	0	0	0	0	0	0	0	0	0
3.B. Manure Management	2	3	3	4	4	6	7	7	8	10	8	8	9	10	9
3.F. Field Burning of Agricultural Residues	-	-	-	-	-	-	-	-	-	-	-	-	-	-	-
4. Land Use, Land-Use Change and Forestry (net)	0	0	0	0	0	0	0	0	0	0	0	0	0	0	0
4.A. Forest Land	0	0	0	0	0	0	0	0	0	0	0	0	0	0	0
4.B. Cropland	-	-	-	-	-	-	-	-	-	-	-	-	-	-	-
4.C. Grassland	-	-	-	-	-	-	-	-	-	-	-	-	-	-	-
4.D. Wetlands	-	-	-	-	-	-	-	-	-	-	-	-	-	-	-
5. Waste	0	0	0	0	0	0	0	0	0	0	0	0	0	0	0
5.A. Solid waste disposal	-	-	-	-	-	-	-	-	-	-	-	-	-	-	-
5.B. Biological treatment of solid waste	-	-	-	-	-	-	-	-	-	-	-	-	-	-	-
5.C. Incineration and open burning of waste	-	-	-	-	-	-	-	-	-	-	-	-	-	-	-
5.D. Waste water treatment and discharge	-	-	-	-	-	-	-	-	-	-	-	-	-	-	-
5.E. Other	0	0	0	0	0	0	0	0	0	0	0	0	0	0	0
	2005	2006	2007	2008	2009	2010	2011	2012	2013	2014	2015	2016	2017	2018	2019
Total National Emissions and Removals	9	10	9	8	7	8	-33	5	4	5	6	19	7	-42	-71
1. Energy	-1	-1	-1	-1	-1	0	0	0	0	0	0	0	0	0	0
1.A. Fuel Combustion Activities	-1	-1	-1	-1	-1	-1	-1	-1	-1	-1	-2	-2	-1	-2	-2
1.A.1. Energy Industries	0	0	0	0	0	0	0	0	0	0	0	0	0	1	1
1.A.2. Manufacturing Industries and Construction	0	-1	-1	0	0	0	0	0	0	0	-1	-1	-1	-2	-2
1.A.3. Transport	0	0	0	0	0	0	0	0	0	0	0	0	0	0	0
1.A.4. Other Sectors	-1	0	0	-1	-1	-2	-1	-1	-1	-1	-1	-1	0	-1	-1
1.A.5. Other	0	0	0	0	0	0	0	0	0	0	0	0	0	0	0

<i>Continued</i>	2005	2006	2007	2008	2009	2010	2011	2012	2013	2014	2015	2016	2017	2018	2019
1.B. Fugitive Emissions from Fuels	0	0	0	0	0	1	1	1	1	1	1	1	1	1	2
2. Industrial Processes and product use	-	-	-	-	-	-	-	-	-	-	-	-	0	0	0
3. Agriculture	10	10	9	9	8	7	6	6	6	7	8	21	24	2	7
3.A. Enteric Fermentation	0	0	0	0	0	0	0	0	0	0	0	0	0	-23	-24
3.B. Manure Management	10	10	9	9	8	7	6	6	6	7	8	21	24	25	31
3.F. Field Burning of Agricultural Residues	-	-	-	-	-	-	-	-	-	-	0	0	0	0	0
4. Land Use, Land-Use Change and Forestry (net)	0	0	0	0	0	0	-39	-2	-2	-2	-2	-2	-2	-2	-2
4.A. Forest Land	0	0	0	0	0	0	0	0	1	1	1	1	1	1	1
4.B. Cropland	-	-	-	-	-	-	-40	-2	-2	-2	-2	-2	-2	-2	-2
4.C. Grassland	-	-	-	-	-	-	-	-	-	-	-	-	-	-	0
4.D. Wetlands	-	-	-	-	-	-	-	-	-	0	0	-	-	-	-
5. Waste	0	0	-	-	-	-	-	-	0	0	0	0	-15	-42	-77
5.A. Solid waste disposal	-	-	-	-	-	-	-	-	-	-	-	-	-	-	-
5.B. Biological treatment of solid waste	-	-	-	-	-	-	-	-	-	-	-	-	-15	-42	-77
5.C. Incineration and open burning of waste	-	-	-	-	-	-	-	-	-	-	-	-	-	-	0
5.D. Waste water treatment and discharge	-	-	-	-	-	-	-	-	-	-	-	-	-	-	-
5.E. Other	0	0	-	-	-	-	-	-	0	0	0	0	0	0	0

Table 9.4 Recalculation for N₂O performed in the 2022 submission for 1990-2019. Differences in kt CO₂ equivalents between this and the April 2021 submission for Denmark. Excluding Greenland and Faroe Islands.

N ₂ O, kt CO ₂ equivalents	1990	1991	1992	1993	1994	1995	1996	1997	1998	1999	2000	2001	2002	2003	2004
Total National Emissions and Removals	254	245	222	243	224	255	245	266	259	242	267	262	264	269	250
1. Energy	1	1	2	2	2	1	2	2	2	2	2	2	1	2	2
1.A. Fuel Combustion Activities	1	1	2	2	2	1	2	2	2	2	2	2	1	2	2
1.A.1. Energy Industries	0	0	0	0	0	0	0	0	0	0	0	0	0	0	0
1.A.2. Manufacturing Industries and Construction	4	4	4	4	3	3	3	3	3	3	3	2	1	1	1
1.A.3. Transport	0	0	0	0	0	0	0	0	0	0	0	0	0	0	0
1.A.4. Other Sectors	-4	-3	-3	-3	-2	-2	-2	-2	-1	-1	0	0	0	0	0
1.A.5. Other	0	0	0	0	0	0	0	0	0	0	0	0	0	0	0
1.B. Fugitive Emissions from Fuels	-	-	-	-	0	-	-	-	-	-	-	-	-	-	-
2. Industrial Processes and product use	-	-	-	-	-	-	-	-	-	-	-	-	-	-	-
3. Agriculture	252	244	219	240	222	253	242	263	255	238	262	257	261	265	246
3.B. Manure Management	0	1	1	2	2	3	5	5	6	6	7	8	8	9	9
3.D. Agricultural soils	252	242	218	238	220	249	237	257	248	231	255	250	253	256	237
3.F. Field Burning of Agricultural Residues	-	-	-	-	-	-	-	-	-	-	-	-	-	-	-
4. Land Use, Land-Use Change and Forestry (net)	0	0	1	1	1	1	1	2	2	2	2	2	2	2	2
4.A. Forest Land	0	0	1	1	1	1	1	2	2	2	2	2	2	2	2
4.B. Cropland	-	-	-	-	-	-	-	-	-	-	-	-	-	-	-
4.C. Grassland	-	-	-	-	-	-	-	-	-	-	-	-	-	-	-
4.D. Wetlands	-	-	-	-	-	-	-	-	-	-	-	-	-	-	-
4.E. Settlements	-	-	-	-	-	-	-	-	-	-	-	-	-	-	-
5. Waste	-	-	-	-	-	-	-	-	-	-	-	-	-	-	-
5.B. Biological treatment of solid waste	-	-	-	-	-	-	-	-	-	-	-	-	-	-	-
5.C. Incineration and open burning of waste	-	-	-	-	-	-	-	-	-	-	-	-	-	-	-
5.D. Waste water treatment and discharge	-	-	-	-	-	-	-	-	-	-	-	-	-	-	-
	2005	2006	2007	2008	2009	2010	2011	2012	2013	2014	2015	2016	2017	2018	2019
Total National Emissions and Removals	242	260	230	250	267	244	255	257	262	302	293	289	279	272	281
1. Energy	1	2	2	4	4	4	5	4	2	2	-2	-3	-1	-3	0
1.A. Fuel Combustion Activities	1	2	2	4	4	4	5	4	2	2	-2	-3	-1	-3	0
1.A.1. Energy Industries	0	0	0	0	0	0	0	0	0	0	0	0	0	0	1
1.A.2. Manufacturing Industries and Construction	1	1	1	3	3	4	4	3	2	1	-2	-2	-1	-2	-1
1.A.3. Transport	0	0	0	0	0	0	0	0	0	0	0	0	0	0	0
1.A.4. Other Sectors	0	1	1	0	0	-1	0	0	0	0	0	-1	0	-1	0
1.A.5. Other	0	0	0	0	0	0	0	0	0	0	0	0	0	0	0
1.B. Fugitive Emissions from Fuels	-	-	-	-	-	-	0	0	-	-	-	-	-	-	-

<i>Continued</i>	2005	2006	2007	2008	2009	2010	2011	2012	2013	2014	2015	2016	2017	2018	2019
2. Industrial Processes and product use	-	-	-	-	-	-	-	-	-	-	-	-	0	0	0
3. Agriculture	239	256	226	243	260	237	247	250	256	297	292	288	276	271	278
3.B. Manure Management	5	5	4	4	3	3	2	2	2	3	4	14	16	17	21
3.D. Agricultural soils	234	251	221	240	258	234	245	248	254	295	288	274	260	254	257
3.F. Field Burning of Agricultural Residues	-	-	-	-	-	-	-	-	-	-	0	0	0	0	0
4. Land Use, Land-Use Change and Forestry (net)	3	3	3	3	3	3	3	3	3	3	3	4	4	4	4
4.A. Forest Land	3	3	3	3	3	3	3	3	3	3	3	4	4	4	4
4.B. Cropland	-	-	-	-	-	-	-	-	-	-	-	-	-	-	-
4.C. Grassland	-	-	-	-	-	-	-	-	-	-	-	-	-	-	0
4.D. Wetlands	-	-	-	-	-	-	-	-	-	-	-	-	-	-	-
4.E. Settlements	-	-	-	-	-	-	-	-	-	-	-	-	-	-	-
5. Waste	-	-	-	-	-	-	-	-	-	-	-	-	-	-	-1
5.B. Biological treatment of solid waste	-	-	-	-	-	-	-	-	-	-	-	-	-	-	-1
5.C. Incineration and open burning of waste	-	-	-	-	-	-	-	-	-	-	-	-	-	-	0
5.D. Waste water treatment and discharge	-	-	-	-	-	-	-	-	-	-	-	-	-	-	-

Table 9.5 Recalculation for f-gases performed in the 2022 submission for 1990-2019. Differences in kt CO₂ equivalents between this and the April 2021 submission for Denmark. Excluding Greenland and Faroe Islands.

f-gases kt CO ₂ eqv	1990	1991	1992	1993	1994	1995	1996	1997	1998	1999	2000	2001	2002	2003	2004
HFCs				-	-	-	-	-	-	-	-	-	-	-	-
PFCs						-	-	-	-	-	-	-	-	-	-
SF ₆															
	2005	2006	2007	2008	2009	2010	2011	2012	2013	2014	2015	2016	2017	2018	2019
HFCs	-	-	-	-	-	-	-	-	-	-	-	-	-	-	-
PFCs	-	-	-	-	-	-	-	-	-	-	-	-	-	-	-
SF ₆	-	-	-	-	-	-	-	-	-	-	-	-	-	-	-

9.4 Recalculations, including those in response to the review process, and planned improvements to the inventory (e.g. institutional arrangements, inventory preparations)

The review on the submissions in 2007 and 2008 was finalised and the report was published 15 April, 2009. For the 2009 submission the review report was finalised and published 15 April, 2010. The review report of the in-country review of the 2010 submission was published 3 March, 2011. The draft review report for the review of the 2011 submission was available 9 February, 2012. The final review report was published 30 April, 2012. The draft review report of the 2012 submission was made available 30 April, 2013 and the final review report was dated 2 August, 2013. The draft review report of the 2013 submission was made available April 28, 2014 and the final review report was dated 23 June, 2014. The draft of the review report from the centralised review carried out in September 2014 was received on December 9, 2014. The final report was published on February 4, 2015. No review took place in 2015. The review of the 2016 submission took place as an in-country review in September 2016. The final report was published on 9 August, 2017. No review took place in 2017. The review of the 2018 submission took place in October 2018. The final report was published on 5 February, 2019. No review took place in 2019. The review of the 2020 submission took place in November 2020 and the final report was published 5 May 2021.

The review of the 2021 submission took place in September 2021. At the time of preparing this report, no draft review report has been provided and hence Table 9.6 has not been updated to reflect the review of the 2021 submission.

The status of the implementation of review recommendations from the latest published review is for the general recommendations included in Table 9.6. For the sector specific recommendations, please refer to the individual sector chapters.

Table 9.6 General recommendations from the latest UNFCCC review.

Para.	CRF	ERT Comment	Denmark's response	Reference
G.2	Annual submission	Estimate and report the following categories for Greenland: HFC emissions from refrigeration and air conditioning (category 2.F.1), SF6 emissions from electrical equipment (2.G.1) and CO2, CH4 and N2O emissions and removals under forest land – drainage and rewetting (4(II)).	This was corrected in the 2021 submission. However, the text in section 16.6.11 of the NIR had not been updated. This has been done for the 2022 submission.	CRF and Chapter 16 of the NIR.
G.3	Annual submission	Estimate the following categories for the Faroe Islands: CO2, CH4 and N2O emissions from missing subcategories under fuel combustion (1.A), CO2 emissions from lubricant use (2.D.1) and paraffin wax use (2.D.2), HFC emissions from refrigeration and air conditioning (2.F.1), SF6 emissions from electrical equipment (2.G.1), indirect N2O emissions from manure management (3.B.5), CH4 emissions from agricultural soils (3.D), CH4 emissions from solid waste disposal (5.A) and CH4 and N2O emissions from wastewater treatment and discharge (5.D)).	In the 2021 submission, the reporting for the Faroe Islands was enhanced to include the identified missing emissions.	CRF and annex 7 of the NIR.
G.6	QA/QC and verification	Update the quality manual from 2013 and ensure its consistency with the revised UNFCCC Annex I inventory reporting guidelines.	The updated manual was published in 2020. This was reported in the 2021 NIR.	Chapter 1.

9.5 Explanations, justifications and implications of recalculations for KP-LULUCF inventory

9.5.1 Recalculations

Almost all sectors in the KP-LULUCF have been recalculated.

For more information on KP-LULUCF recalculations please refer to Chapter 10.

9.5.2 Review recommendations

The recommendations for KP-LULUCF are included in Chapter 10.

10 KP-LULUCF

10.1 General information

For this chapter, the following abbreviations are used in accordance with definitions in the IPCC guidelines:

A:	Afforestation
R:	Reforestation
D:	Deforestation
FF:	Forest remaining Forest, areas remaining forest after 1990
FL:	Forest Land meeting the Danish definition of forests
CL:	Cropland
GL:	Grassland
WE:	Wetlands
SE:	Settlements
OL:	Other land, unclassified land
FM:	Forest Management, areas managed under article 3.4
HWP:	Harvested Wood Product
CM:	Cropland Management, areas managed under article 3.4
GM:	Grazing land Management, areas managed under article 3.4
RV:	Revegetation
WDR:	Wetland Drainage and Rewetting
CP:	Commitment Period

Other abbreviations:

EO:	Earth Observation
NFI:	National Forst Inventory
LPIS:	Land Parcel Information System
FMRL:	Forest Management Referech Level
HWP:	Harvested Wood Products
SINKs2:	SINKs 2 is a Danish funding project for the 2 nd commitment period

10.1.1 Definition of forest and any other criteria

For the estimation of anthropogenic emissions by sources and removals by sinks associated with afforestation (A), reforestation (R) and deforestation (D) since 1990 under Article 3.3 and forest management (FM) under Article 3.4 of the Kyoto Protocol, the following forest definition will be applied:

Forest refer to an area larger than 0.5 ha and wider than 20 m with a tree canopy cover of more than 10 percent of trees taller than 5 m or of trees able to reach these thresholds *in situ*.

In addition, the forest area includes temporarily unstocked areas, smaller open areas in the forest needed for management purposes and fire breaks. Forests in national parks, reserves, or areas under special protection are included. Windbreaks and groves covering more than 0.5 ha and with a minimum width of 20 m are also considered forest. Farmlands, fruit plantations for commercial purposes, orchards, gardens (houses and summer houses) are NOT included in the forest area. Willow plantations on agricultural soils for bioenergy purposes are included in Cropland (CL).

10.1.2 Elected activities under Article 3.4 of the Kyoto Protocol

Regarding the possibility of including the first commitment period emissions and removals associated with land use, land-use change and forestry activities under Article 3.4 of the Kyoto Protocol, it has been decided to include emissions and removals from forest management (FM), cropland management (CM) and grazing land management (GM). Revegetation and Wetland Drainage and Rewetting (WDR) is not elected by Denmark in the second Commitment Period (CP).

Natural disturbances are very seldom in Denmark and has not been elected.

Reporting is required by parties that apply the provision in decision 2/CMP.7, annex, and paragraphs 37-39 on Carbon Equivalent Forests. Denmark has decided not to use this in its accounting.

The Danish territory covers mainland Denmark and Greenland, but not the Faroe Islands. The Faroe Islands has not signed the Kyoto-Protocol and has therefore not submitted KP tables or been included in the Danish and the Greenlandic submission.

The tables in this chapter covers only the Danish territory and not data from Greenland and thus only data, which shall be included in the submission to the European Union (EU) and for the 2nd commitment period of the Kyoto Protocol.

For Greenland separate CRF and KP tables are produced, see Chapter 16. The Greenlandic tables are named: **GRL**.

The Greenlandic impact on the overall estimates is very low: <0,01 % and thus the figures given below can be regarded as very proximate values for both Denmark and Greenland.

The Danish and the Greenlandic CRF and KP tables are merged into one set of CRF and KP tables and named: **DKE**.

The national system has identified land areas associated with the activities under Article 3.4 of the Kyoto Protocol in accordance with definitions, modalities, rules and guidelines relating to land use, land-use change and forestry activities under the protocol by satellite monitoring, use of Land Parcel Information System (LPIS) from the EU subsidiary system as well as the Greenlandic subsidiary system, detailed crop information data on field level, soil mapping and sample plots from the national forest inventory (NFI).

Inventories of emissions and removals under Article 3.3 and Article 3.4 are prepared for 2013 and onwards, and reported annually together with the other greenhouse gas inventory information.

10.1.3 Description of how the definitions of each activity under Article 3.3 and each elected activity under Article 3.4 have been implemented and applied consistently over time

The definition of afforestation, reforestation and deforestation is in accordance with the Supplementary GPG (IPCC 2014).

Afforestation (A) or reforestation (R) is identified when areas have wooded tree cover and fulfils the forest definition given above. The time of the A is given by the time of action - i.e. planting of trees. For R, the time is given by the first spontaneous regeneration of trees, typically either by absence of management or by management inducing natural regeneration. All types of establishment of forest (A or R) are considered human induced, as all land area of Denmark is under management or as minimum specifically left for spontaneous revegetation. Regulations and support for A and R include natural revegetation as a specific method, often supplementing already existing forest areas. (Danish Forest and Nature Agency, Support for afforestation <http://mst.dk/natur-vand/natur/tilskud-til-skov-og-naturprojekter/>).

Deforestation is identified where areas in 1990 were covered by forest and where subsequent information (through remote sensing, NFI or LPIS) is recorded to have another land use. Deforestation occurs for a number of reasons, e.g. nature restoration, which in the period 1990 - 2020 have been the predominant reason. Other reasons may be urban or infrastructure development.

Temporarily unstocked areas - as integral part of forest management or as result of windthrow - which is expected to continue in forest management - is not considered as deforestation. Distinction between temporarily unstocked areas and deforestation is based on either specific information or more than 10 years of no tree cover.

As for the forest management (Article 3.4) - the forest areas fulfilling the definition given above are included under this activity. All forest areas are considered managed due to the intense utilisation of the land area of Denmark. The Forest Act in Denmark gives the frame for most of the forest area ('Fredskov' constitutes approx. 70 %) - thereby ensuring continued forest cover - or by deforestation at least afforestation of a similar area or in most cases the double area. As described in Chapter 6, the changes in forest floor and mineral soils pools are not significant in the period observed (1990-2020) and thus not considered being a source of emissions.

For Cropland and Grassland, the area accounted for under Art. 3.4 has been estimated with the Earth Observation (EO) mapping combined with agricultural data from Statistics Denmark, Statistics Greenland and the EU agricultural subsidiary system. Only activities, which began after January 1st 1990 are included in the inventory. Only areas reported as CL and GL are included in the accounted area.

10.1.4 Description of precedence conditions and/or hierarchy among article 3.4 activities and how they have been consistently applied in determining how land was classified

All Forest activities have precedence, after this Cropland activities and then Grassland activities.

Afforestation has precedence. All land converted to forest are included as afforested area. Deforested areas are reported under D. The following categories in the Convention reporting are included under afforestation:

- 4A21 CL to A
- 4A22 GL to A
- 4A23 WE to A
- 4A24 SE to A
- 4A25 OL to A

Deforestation is estimated as:

- 4B21 to CL
- 4C21 to GL
- 4D21 to WE
- 4E21 to SE
- 4F21 to OL

Forest Management activities are only related to:

- 4A1 Forest remaining Forest

Cropland Management activities are related to:

- 4B1 CL remaining CL
- 4B22 GL to CL
- 4B23 WE to CL
- 4B24 SE to CL
- 4B25 OL to CL
- 4D22 CL to WE
- 4E22 CL to SE
- 4F22 CL to OL (not occurring)

Grazing land Management activities are related to:

- 4C1 GL remaining GL
- 4C22 CL to GL
- 4C23 WE to GL
- 4C24 SE to GL
- 4C25 OL to GL
- 4D23 GL to WE
- 4E23 GL to SE
- 4F23 GL to OL (not occurring)

No elected land has left land, which it is accounted for. Land conversion between elected activities (FM, CM and GM) has been allowed. FF, CL and GM, which has been converted to WE and SE are still included in the accounted area. No land elected under 3.4 activities has been converted to Other Land. No Other Land, represented as WE, has been converted to land included in Art. 3.3 and 3.4 activities. As a consequence, there has been a small decrease in Other land, which is accounted for under Art. 3.3 and Art. 3.4 (Table 10.1) with 445 hectares from 2013 to 2020 which is mainly caused by a conversion of WE til CM.

Table 10.1 The area development in the different Kyoto Protokol classes, which are included in the accounting (only mainland Denmark) 1990 to 2020 (ha).

	1990	2013	2014	2015	2016	2017	2018	2019	2020
Afforestation	4328	99621	100127	102955	104741	105879	107789	109315	112328
Deforestation	121	6904	7367	9951	11797	11819	13221	13743	15540
Forest management	544417	537633	537171	534587	532741	532719	531317	530795	528998
Crop management	-	2902183	2885275	2872475	2867478	2863066	2862833	2859337	2857406
Grazing land management	-	149388	165816	175995	179416	182691	181014	182984	181902
Other land	-	609823	609797	609590	609380	609378	609378	609378	609378
Total area, hectares	4305552	4305552	4305552	4305552	4305552	4305552	4305552	4305552	4305552

The Land Use matrix developed for the purpose of reporting Art. 3.3 and 3.4 activities for 2020 are shown in Table 10.2.

Table 10.2 Land Use matrix for Art. 3.3 and 3.4 activities from 2019 to 2020, in 1000 hectares.

	ARTICLE 3.3 ACTIVITIES		ARTICLE 3.4 ACTIVITIES			Other	Total area at the end of the previous inventory year
	Afforestation and reforestation	Deforestation	Forest management	Cropland management	Grazing land management	Other	
Article 3.3 activities	(kha)						(kha)
Afforestation and reforestation	109.32	NO					109.32
Deforestation		13.74					13.74
Article 3.4 activities							
Forest management		1.80	529.00				530.80
Cropland management	2.84		NO	2851.81	4.68		2859.34
Grazing land management	0.17		NO	5.59	177.22		182.98
Other	NO	NO	NO	NO	NO	609.38	609.38
Total area at the end of the current inventory year	112.33	15.54	529.00	2857.41	181.90	609.38	4305.55

Table 10.3 shows the estimated accounting parameters for the period 2013-2020. Afforestation is assumed to give a net credit of -2610 kt CO₂ eqv. to the Danish reduction commitment in the 2nd commitment periode for the period 2013-2020. Deforestation has been estimated to give a net debit of 2679 kt CO₂ eqv. for the years 2013 to 2020. Forest Management has shown to be a net credit of -23 767 kt CO₂ eqv, exceeding the Forest Management cap of -19 822 kt CO₂ eqv. Chapter 6 for further details on uncertainty and reporting periods as well as planned improvements.

Cropland Management has been estimated to give a net credit of -22 053 kt CO₂ eqv. whereas Grazing land Management has been estimated to yield a credit of -2442 kt CO₂ eqv.

Table 10.3 Estimated accounting quantities for the period 2013-2020, kt CO₂ eqv.

GREENHOUSE GAS SOURCE AND SINK ACTIVITIES	Base Year	NET EMISSIONS/REMOVALS									Accounting parameters	Accounting quantity	
		2013	2014	2015	2016	2017	2018	2019	2020	Total			
	(kt CO ₂ eq)												
A. Article 3.3 activities													
A.1. Afforestation/reforestation		-110	-221	-287	-278	-343	-485	-610	-275	-2610			-2610
A.2. Deforestation		66	175	677	567	40	418	214	522	2679			2679
B. Article 3.4 activities													
B.1. Forest management													-23767
Net emissions/removals		-3374	-3831	-3859	-2993	-2406	-1806	-1950	-937	-21156			
Forest management reference level (FMRL)											409		
Technical corrections to FMRL											-83		
Forest management cap											19822		-19822
B.2. Cropland management	5545	2422	3561	2451	2610	2208	3302	2994	2757	22305			-22053
B.3. Grazing land management	2371	1811	1954	1992	2118	2059	2186	2152	2255	16527			-2442

The above given information in the hierarchy between the Convention and the KP-LULUCF activities ensures that emission from activities under article 3.4 are not double counted under both article 3.3 and 3.4 activities.

10.2 Land-related information

10.2.1 Spatial assessment unit used for determining the areas of the units of land under Article 3.3

Afforestation and reforestation are identified as areas in 1990, which are not covered by forest and where subsequent information (through remote sensing or NFI) is recorded to have forest cover fulfilling the forest definition. Even though the definition for A and R refers to the time of establishment, there may be a slight time delay in the actual recording of the A/AR. This will be improved through more frequent land use mapping and improved methods for mapping in the coming years.

Deforestation is identified as areas covered by forest at the beginning of the commitment period and where subsequent information (through remote sensing or NFI) is recorded to have another land use. The identification of the areas is in most cases supported by reports on e.g. nature restoration or establishment of settlements.

10.2.2 Methodology used to develop the land transition matrix

A land use/land cover map was produced for the Kyoto reference year 1990, 2005 and 2011 based on EO data for the forest land use. For almost all other land uses the main data comes from detailed vector maps. These include data such as different vector layers from cadastral maps, road maps, wetland areas, agricultural land use data, vector layers of established wetlands, gravel maps etc. as well as aerial photos. The primary data used for the forest land use mapping is Landsat imagery, mainly Landsat 5 (TM) and 7 (ETM+) data, to classify and estimate the area and in combination with NFI data and other sources of data, including airborne laser scanning (LiDAR) data. The product is specified by a Minimum Mapping Unit (MMU) of 0.5 ha, a geometric accuracy of < 15 m RMS and a thematic accuracy of 90% +/- 5%.

The land use was allocated to the six major Kyoto classes: Forest, Cropland, Grassland, Wetland, Settlements, and Other. Highest priority was given to maps having the highest reliability in the production of the land use matrix. To avoid transition artefacts due to minor updates in the precision of the vector maps, a Minimum Mapping Unit (MMU) for land use change has been set to 0.5 ha, which is the same as the elected Danish minimum MMU for forests in the Initial Report under the Kyoto protocol: http://unfccc.int/files/national_reports/initial_reports_under_the_kyoto_protocol/application/pdf/aareporttounfccc-20dec2006.pdf

Table 10.1 shows the overall development of the area of the five Kyoto Protocol classes, from 1990 to 2020. The result shows an increase in the afforested area of 112 328 hectares, but also that deforestation has taken place on approximately 15 540 ha. Afforestation is mainly taking place on CL and GL. Areas, which are deforested, are mainly converted to CL and GL areas with agricultural crops in rotation or permanent grass. Only to a small extent is forest converted to SE.

Since 1990, almost 52 488 hectares have changed into SE. No FF, CL and GL has been converted into OL by definition.

A validation of the map and the change estimates are reported in Johannsen et al. 2018.

10.2.3 Maps and/or database to identify the geographical locations, and the system of identification codes for the geographical locations

The entire Danish territory (Denmark and Greenland) except the Faroe Islands is included in the Kyoto-reporting. The text in this chapter includes only the territory of Denmark without Greenland. Denmark is reported as one unit and no sub-geographical locations are used.

Greenland is submitting a full separate NIR and CRF to be included in the submission to UNFCCC (Chapter 16).

10.3 Afforestation, Reforestation & Deforestation (ARD)

10.3.1 Methods for carbon stock change and GHG emission and removal estimates

For afforestation, the carbon stock change estimates in the period 1990 - 2020 are based both on the area of afforestation, the information on species composition from the Forest Census 1990, 2000 and from the NFI that started in 2002. Afforestation include ordinary afforestation as well new stands of Christmas trees on agricultural land (see also Schou et al., 2014 for further description of afforestation since 1990).

The estimates for the carbon pools for the afforestation area is consistent for all years.

Carbon stock change caused by deforestation are handled separately for the ordinary forests area and for the Christmas tree area. For the ordinary forest area the carbon stock changes are estimated based on the deforested area, and the mean values of carbon stock per hectare of the total forest area in the period 1990-2015. From 2015, the estimates of carbon removals for the ordinary forest area are based on combined information from a national mapping of biomass, based on canopy height estimated with Lidar data (Schumacher et al., 2013, Nord-Larsen et al., 2017) and the land use map, giving geographically specific information on the deforested areas. With this combination of data, details on the deforestation and the related decreases in carbon pools can be extracted. For the area of Christmas trees the deforestation is based on the average carbon pools for the Christmas tree areas.

In case of deforestation, the living and dead biomass (deadwood and litter layer) were assumed removed and oxidized instantly. Furthermore, the N₂O emission from nitrogen mineralization in the litter layer is calculated by dividing the C pool with a C:N ratio of 25 and an emission factor of 0.01. A large part of the deforestation is conversion of forest to restore wetlands by clear-cutting the forest and closing the drainage systems.

Further details are available in Johannsen et al. (2011).

10.3.2 Underlying assumptions

The climate in Denmark is cold and wet, which limits the growth of the forests. Therefore afforestation in Denmark requires long rotations (> 50 years), before they give an acceptable amount of wood and wood products for final harvesting. The afforested areas are in many cases protected against deforestation by law, and therefore, afforested areas under article 3.3. will seldom be deforested during the commitment period.

10.3.3 Justification when omitting any carbon pool or GHG emissions/removals from ARD (Afforestation, Reforestation and Deforestation)

When deforestation occurs, it is assumed that all dead biomass, including deadwood and litter layer, will be cleared. The actual amount depends on which type of forest is converted.

10.3.4 Information on whether or not indirect and natural GHG emissions and removals have been factored out

No factoring out has been performed in the emission and removal estimates.

10.3.5 Changes in data and methods since the previous submission (recalculations)

Recalculations table for KP for 2019.

Table 10.4 Recalculation table for KP (4(KP)Recalculations).

Activities	CO2			
	Previous submission	Latest submission	Difference	Difference ⁽¹⁾
	(kt)			(%)
4 (KP). Land Use, Land-Use Change and Forestry	2293.76	2339.66	45.90	2.00
4 (KP-I) A.1 Afforestation and reforestation	-651.61	-618.66	32.94	-5.06
Carbon stock change in above-ground biomass	379.40	370.73	-8.67	-2.28
Carbon stock change in below-ground biomass	91.69	67.41	-24.27	-26.47
Net carbon stock change in litter	162.46	162.46	0.00	0.00
Net carbon stock change in dead wood	6.13	6.13	0.00	0.00
Net carbon stock change in mineral soils	64.38	64.38	0.00	0.00
Net carbon stock change in organic soils	-52.45	-52.45	0.00	0.00
Net carbon stock change in HWP	IE	IE		
4 (KP-I) A.2 Deforestation	238.97	85.25	-153.73	-64.33
Carbon stock change in above-ground biomass	-138.76	-10.66	128.11	-92.32
Carbon stock change in below-ground biomass	-25.92	-0.29	25.62	-98.86
Net carbon stock change in litter	-28.59	-28.59	0.00	0.00
Net carbon stock change in dead wood	-2.65	-2.65	0.00	0.00
Net carbon stock change in mineral soils	-18.55	-18.55	0.00	0.00
Net carbon stock change in organic soils	-20.64	-20.64	0.00	0.00
Net carbon stock change in HWP	-3.86	-3.86	0.00	0.00
4 (KP-I) B.1 Forest management	-1986.41	-1986.42	-0.01	0.00
Carbon stock change in above-ground biomass	838.20	838.20	0.00	0.00
Carbon stock change in below-ground biomass	177.89	177.89	0.00	0.00
Net carbon stock change in litter	881.11	881.12	0.01	0.00
Net carbon stock change in dead wood	131.97	131.97	0.00	0.00
Net carbon stock change in mineral soils	NO,NA	NA		
Net carbon stock change in organic soils	-122.80	-122.80	0.00	0.00
Net carbon stock change in HWP	80.04	80.04	0.00	0.00
4 (KP-I) B.2 Cropland management (if elected)	2726.77	2893.47	166.69	6.11
Carbon stock change in above-ground biomass	18.63	28.51	9.88	53.05
Carbon stock change in below-ground biomass	-52.39	-52.16	0.23	-0.43
Net carbon stock change in litter	NO	NA		
Net carbon stock change in dead wood	NO	NA		
Net carbon stock change in mineral soils	-26.95	-203.75	-176.80	656.03
Net carbon stock change in organic soils	-2666.06	-2666.06	0.00	0.00
4 (KP-I) B.3 Grazing land management (if elected)	1966.03	1966.03	0.00	0.00
Carbon stock change in above-ground biomass	-96.10	-96.10	0.00	0.00
Carbon stock change in below-ground biomass	-2.20	-2.20	0.00	0.00
Net carbon stock change in litter	NO	NA		
Net carbon stock change in dead wood	NO	NA		
Net carbon stock change in mineral soils	48.89	48.89	0.00	0.00
Net carbon stock change in organic soils	-1916.61	-1916.61	0.00	0.00

Changes related to afforestation

To account for the grasses and herbs in the first 25 years of afforestation (corresponding to the situation in grasslands), an estimate of this is included. In practice it is assumed that afforestation initially will hold the same pools of AGB and BGB as unmanaged grassland (Table 6.12). These pools will linearly decrease over a period of 25 years, reflecting the reduced light to ground vegetation from the increasing crown cover of the trees established in the afforestation. This is supported by a number of observations of afforestation, with data for both trees and grass vegetation.

Changes related to Deforestation

For Deforestation an error were corrected in the emission for living biomass for Christmas trees. In the 2021 submission there were a multiplication with

about 1000 for living biomass giving a far too high loss when land with Christmas trees were converted to Cropland/Grassland.

10.3.6 Uncertainty estimates

Not estimated under KP. Please refer to Chapter 6 for the overall LULUCF sector.

10.3.7 Information on other methodological issues

See Chapter 6.

10.3.8 The year of the onset of an activity, if after 2008

Not applicable.

10.4 Forest Management (FM)

10.4.1 Methods for carbon stock change and GHG emission and removal estimates

See Chapter 6 in LULUCF on "Forest remaining forest (4.A.1)".

The area of "natural forests" is very limited in Denmark and these are designated as protected. There is no conversion of these "natural forests" to planted forests and hence no emissions from these areas.

Methodological consistency between the forest management reference level (FRML) and reporting for forest management is ensured.

The total area of Christmas trees are included in FM. This applies to Christmas trees area both within the forest area and the area outside the forest border, which is reported separately.

10.4.2 Methodologies and the underlying assumptions

See Chapter 6 in LULUCF on "Forest remaining forest (4.A.1)".

10.4.3 Omission of pools from FM

No pools omitted.

10.4.4 Factoring out

No factoring out has been made.

10.4.5 Recalculations

Recalculations to ensure independent data in the change estimates have been implemented for all the years and for all the categories of forest area. Only minor technical corrections with regard to data checks.

10.4.6 Information on other methodological issues

See Chapter 6 in LULUCF on "Forest remaining forest (6.2)".

10.4.7 The year of the onset of an activity, if after 2008

Not applicable.

10.5 Forest Management Reference level (FMRL)

The value inscribed in the appendix to annex of decision 2/CMP.7 is reported to 409 kt CO₂-eqv yr⁻¹ for the second commitment period. For year 2015, a technical correction has been calculated to -83 kt CO₂-eqv yr⁻¹ consisting of a correction of the HWP contribution and a technical correction to the Forest Management Reference Level (FMRL) to ensure reporting consistency.

Emissions from harvested wood products originating from forests prior to the start of the second commitment period – cf. paragraph 1(j) in Annex I to Decision 2/CMP.8

The technical correction is documented by Schou et al. 2015).

For the second commitment period, a corrected FMRL is estimated specifying the expected average annual net emissions from the HWP pool. Due to the data corrections, it was decided to correct the original FMRL reported in 2011 (Johansen et al. 2011). This correction also entailed a change in the reference period used to project the inflow to the HWP pool – from 2005-2009 to 2008-2012. In order to provide a more accurate reference level using the most recently collected data, the reference period has not been changed. The previous FMRL would have significantly underestimated the inflow for 2013 and thus caused a significant gap between the reported net emissions and the net emissions projected by the FMRL. This would have meant that the HWP pool would actually have been projected to decrease as opposed to the expected increase in the pool, during the second commitment period.

The corrected FMRL has projected the inflow in 2013 to approximately 132,000 tonnes carbon (61,000 tonnes from sawnwood and 71,000 tonnes from wood-based panels), and the outflow to approximately 110,000 tonnes carbon in 2013 (65,000 tonnes from sawnwood and 45,000 tonnes from wood-based panels). The projected net sequestration this year is estimated to 22,000 tonnes carbon. Thus, the corrected FMRL projects an average annual net emission of -65 kt CO₂-eqv. yr⁻¹ covering the entire second commitment period. Hence, the HWP pool is projected to increase over the period.

Emissions from forest management

Regarding the FMRL for forest management, the revision is based on technical improvements of calculations, ensuring consistency with the reporting techniques. This relates to the previously mentioned biomass expansion functions (Chapter 6.2). The updated revision also includes pools for soil, including mineral and organic soil in the depth 0-100 cm and the emissions of all tree greenhouse gasses (CO₂, CH₄ and N₂O). The overall technical corrections are included in Table 10.4.

Overall technical correction

The overall result shows that the forest in the FMRL will continue to be a source of emissions, while HWP with the new data from SINKS2 project will be a sink in the overall FMRL.

With this, Denmark has a technical correction to the FMRL as shown in Table 10.4.

Table 10.4 Values given in the appendix to the annex of decision 2/CMP.7 for FMRL for instant oxidation and first order decay and the performed technical correction for HWP.

	Assuming instantaneous oxidation of HWP kt CO ₂ eqv. yr ⁻¹	FMRL applying first order decay function for HWP kt CO ₂ eqv. year ⁻¹
Decision 2/CMP.7	334	409
Technical correction	+58	-83
Sum	392	326

10.6 Cropland Management (CM)

10.6.1 Methods for carbon stock change and GHG emission and removal estimates

CL is subdivided in four classes: agricultural CL, wooded perennial fruit plantations, hedgerows and “other agricultural CL”.

10.6.2 Methodologies and the underlying assumptions used

The area with agricultural CL is given as the agricultural area in Statistics Denmark for cereals, fodder crops, grass for seed, sugar beets, potatoes and other root crops.

Land converted from other Land use categories to CL is included under CL. Land converted to forest is reported under forest (A and R). Land, which according to the land use matrix is converted to WE and SE are still included in CM. Land conversion to OL is not allowed.

The same methodology, as used in the Convention reporting, is used in the KP reporting.

10.6.3 Omission of pool from CM

Aboveground and belowground living biomass, litter and dead organic are only reported for perennial woody crops, in accordance with IPCC Supplementary GPG 2014. No litter and dead organic matter are reported under CM, as this is seen as not occurring, or as very insignificant because it only related to a small area with fruit plantations and hedges. Therefore, only above- and belowground living biomasses for perennial fruit plantations, hedgerows and willow plantations for bioenergy purposes on agricultural land, are reported under CM. CL converted to other land uses, such as WE and SE, is assumed not to store litter and other dead organic matter. Christmas trees are reported under Forest management.

10.6.4 Factoring out

The latter years increase in the temperature, results in a higher turn-over rate of organic matter in soils, which haven lead to an increased emission from soils compared to pre 1990. A dynamical temperature dependent model (Tier 3) is used for the agricultural soils, which is expected to give the best estimate of the actual emission reflecting the Danish soil and climate conditions. Had Denmark used the default IPCC Tier 1 or 2 there, it would likely have been a *negative* factoring out, because the emission factor in these methods are based on long-term scientific data, and thus not having the recent increase in temperatures included. Therefore by using the actual temperature in the Tier 3, no factoring out has been made.

10.6.5 Recalculations

Two recalculations was made in Cropland Management.

A minor reallocation of raised hedges between 2018 and 2019 and a major recalculation was made for Cropland mineral soils for the whole timeserie. This because an error was identified in the C-TOOL calculation on the incorporated amount of wheat straw which was overestimated. The consequence estimated higher emissions for all years because the less input is not counterbalanced with the degradation in the soil. In terms of accounting for Cropland Management was in the previous submission estimated an accounting of -17 833 kt CO₂-eqv. for the period 2013-2019. In the current submission has the accounting for 2013-2019 been estimated to -19 548 kt CO₂-eqv. or an increase of 1715 kt CO₂-eqv or 9.6 % (Table 10.4).

10.6.6 Uncertainty estimates

Not estimated separately under KP. Please refer to Chapter 6 for the entire LULUCF sector.

10.6.7 Information on other methodological issues

None.

10.6.8 The year of the onset of an activity, if after 2008

Not applicable.

10.7 Grazing land management (GM)

10.7.1 Methods for carbon stock change and GHG emission and removal estimates

Grazing land is defined as land used for permanent grazing as well as dry land not meeting the definitions for FL, CL, WE or SE. GL is subdivided into two types: Land strictly used for grazing and other grassland. Land used for grazing has no wooden vegetation, whereas other grassland may have some wooden vegetation, that does not meet the forest definition. The area with strict grazing land is the remaining area between the grazing area and the grassland area in the land use matrix. All hedges are reported under CM.

10.7.2 Description of the methodologies and the underlying assumptions used

As all the grazed grassland is more or less unimproved without fertiliser or limited fertilisation, no changes in management practice has been applied. This is in accordance with IPCC 2006 Chapter 6 and IPCC Supplementary GPG Chapter 2.10.

For land converted to GL and not purely free of wooden trees/bushes, it is assumed that there is a living biomass of 2,200 kg DM per ha in above ground biomass and 6,160 kg DM per ha in below ground biomass (IPCC 2006). No changes in soil carbon stock in mineral soils are assumed for Grazing land, which is under heathland and other non-agricultural influence. Carbon stock changes in mineral soils for Grazing land, which are under agricultural influence, are included in the dynamic modelling with C-TOOL and hence reported under Cropland Management. For organic soils, an emission as reported in Chapter 6 is assumed.

10.7.3 Factoring out

No factoring out has been made.

10.7.4 Recalculations

No recalculation has been made.

10.7.5 Uncertainty estimates

Not estimated under KP. Please look in chapter 6 for the whole LULUCF sector.

10.7.6 Information on other methodological issues

None.

10.7.7 The year of the onset of an activity, if after 2008

Not applicable.

10.8 Article 3.3

10.8.1 Information that demonstrates that activities under Article 3.3 began on or after 1 January 1990 and before 31 December 2012 and are direct human-induced

The land use mapping in 1990, 2005, 2011 and 2012-2020 is the documentation for activities under Article 3.3 - after 1.1.1990. As all land area is under management, all changes are evaluated as direct human induced. This also includes A and R, which are based on approved methods of establishing new forest - both planting and natural revegetation. In some cases the absence of removal of tree growth is an easy and cheap method for establishing new forest. Hence this method has also been supported through public support for establishment of new forest areas.

10.8.2 Information on how harvesting or forest disturbance that is followed by the re-establishment of forest is distinguished from deforestation

Deforestation is detected by information from the Danish Building registry, cadastral maps and the annual update of the Land Parcel Information System on agricultural activities. Furthermore, deforestation of larger areas is confirmed by e.g. projects on nature restoration. Temporarily unstocked areas are typically located within larger forest areas and will in most cases be reforested within a period of 10 years as according to the Forest Act of Denmark, which applies to all Legal Forest Reserves (Fredsskov) and equals approximately 70 % of the total forest area. Clearcuts outside forests, e.g. small plantations of conifers on former cropland, is considered as deforestation and will most often be recorded through the LPIS system. Deforestation within the forest area boundaries (e.g. caused by change in hydrology or restoration of open areas by means of grazing), will be documented with a new forest cover/forest land use mapping, when resources become available.

Most forest areas - including new forest areas - are subject to intermediate thinnings. This is done with the purpose of reducing stem number and often to produce firewood or wood chips. Clearcuts of new forest areas occur in most cases first at maturity of the stand after 50-150 years. A subset of the new

forest area are managed as coppice like management, e.g. for production of christmas trees.

10.8.3 Information on the size and geographical location of forest areas that have lost forest cover but which are not yet classified as deforested

This is a small area in Denmark and mainly unstocked areas within the forest area. These areas will most likely be replanted within 10 years and therefore kept as Forest Land. A geographic location of these areas would require more frequent updates of mapping of tree cover/forest land use based on e.g. remote sensing data.

10.8.4 Uncertainty on article 3.3 activities

Not estimated under KP. Please refer to chapter 6 for the whole LULUCF sector.

10.9 Article 3.4

10.9.1 Information that demonstrates that activities under Article 3.4 have occurred since 1 January 1990 and are human induced

Forest Management

In FM, all forest area is under management and changes in carbon stock are hence seen as human induced. The baseline for 1990 is estimated as documented in Johannsen et al. 2011.

Cropland Management

Since 1990, major changes have taken place in Danish agriculture. Due to environmental demands for "green crops during winter", the previous major crop, spring barley, has been replaced by primarily winter wheat. Furthermore, a ban on field burning was implemented in January 1990 (Executive order NO. 142 of 08/03/1989). This has reduced the burning of field residues, which were widely occurring until then. Furthermore, as part of actions to reduce the nitrogen leaching, Executive order NO. 624 of 15/07/1997, the farmers is met with requirements of a certain percentage of the area have to be grown with an extra crop after harvest of annual crops. Currently about eight per cent of the agricultural area is growing an extra crop. From 2003, agricultural areas have been taken out of rotation due to demanded borders along watersheds to protect the watersheds. Specific subsidies, based on EU single payment schemes, to the farmers targeted towards organic soils are currently taking place. The size and location of these areas taken from the LPIS is used in qualifying the effect on emission for CL and GL converted to WE. These areas are included in CM and GM.

Grassland Management

No specific activities have taken place in Grassland to increase or decrease the carbon stock. GM was elected so that all human induced activities affecting the carbon stock in the landscape are included in the Danish commitments under the Kyoto Protocol. Furthermore, it is very difficult to distinguish between activities in CM and GM in the heterogenic patchy Danish landscape.

10.9.2 Information relating to Cropland Management. Grazing Land Management and Revegetation, if elected, for the base year

No further information is available.

10.9.3 Information relating to Forest Management

No further information is available.

10.9.4 Uncertainty on article 3.4 activities

Not estimated under KP. Please refer to Chapter 6 for the entire LULUCF sector.

10.10 Harvested Wood Products

HWP accounting in the current commitment period is solely based on changes in the HWP pool in this period. Therefore the emissions in the first commitment period have no influence on the current reporting. Furthermore, Denmark has also reported on article 3.4 in the first commitment period.

No further information is available. Please refer to Chapter 6 for further description of HWP.

10.11 Other information

10.11.1 Key category analysis for Article 3.3 activities and any elected activities under Article 3.4

According to the 2013 Revised Supplementary GPG (Chapter 2.3.6) for LULUCF, a category that is identified as key in the UNFCCC inventory should also be considered key under the Kyoto Protocol.

In 2013, the following LULUCF categories were identified as key categories in the UNFCCC reporting:

- Forest land remaining forest land.
- Cropland remaining cropland – living biomass
- Cropland remaining cropland – organic soils
- Cropland remaining cropland – mineral soils
- Grassland remaining grassland – living biomass

According to Table 5.4.4 in the IPCC GPG for LULUCF, this means that the following Kyoto Protocol activities are initially considered key.

Table 10.5 Relationship between activities in the UNFCCC LULUCF and the KP-LULUCF.

LULUCF activity	KP-LULUCF activities
Forest land remaining forest land	FM, GM, CM
Land converted to forest land	A and R
Cropland remaining cropland	CM
Grassland remaining grassland	GM

For Denmark, the relevant KP-LULUCF activity corresponding to forest land remaining forest land identified as being a key category in the UNFCCC reporting is FM. Land converted to forest afforestation/reforestation is a key category. For cropland remaining cropland, the relevant KP-LULUCF activity is CM. For grassland remaining grassland, the relevant KP-LULUCF activity is GM.

Therefore A, R, FM, CM and GM are considered key categories in the Danish KP-LULUCF inventory.

For the full list of identified key categories please refer to Annex 1.

10.12 Information relating to Article 6

There are no Article 6 projects (Joint Implementation) on the Danish territory.

10.13 References

IPCC, 2014: "2013 Revised Supplementary Methods and Good Practice Guidance Arising from the Kyoto Protocol." edited by T. Hiraishi, T. Krug, K. Tanabe, N. Srivastava, J. Baasansuren, M. Fukuda and T.G. Troxler. Switzerland, 2014.

Johannsen, V.K., Nord-Larsen T. & Suadicani, K., 2011: Submission of information on forest management reference levels by Denmark. Forest & Landscape Working Papers No. 58-2011, 34 pp. Forest & Landscape Denmark, Frederiksberg. Available at:

https://unfccc.int/files/home/application/pdf/awgkp_denmark_2011.pdf

Johannsen, V.K., Levin, G., Caspersen, O.H., Nord-Larsen, T., & Sørensen, I.H. 2018: Validation of land use/land cover changes for Denmark. Department of Geosciences and Natural Resource Management, University of Copenhagen, Frederiksberg. 23 p. ill. Available at: https://static-curis.ku.dk/portal/files/209289237/Validation_of_land_use_land_cover_changes_for_Denmark_report_2018.pdf

Nord-Larsen, T., Riis-Nielsen, T., & Ottosen, M.B. 2017: Forest resource map of Denmark: Mapping of Danish forest resource using ALS from 2014-2015. Department of Geosciences and Natural Resource Management, University of Copenhagen. IGN Report. Available at: https://static-curis.ku.dk/portal/files/177147904/LiDAR2014_report.pdf and online version <https://ign.ku.dk/samarbejde-med-ign/forskningsbaseret-raadgivning/skovovervaagning/kort-over-skovressourcer/>

Schou, E., Johannsen, V.K., Nord-Larsen, T., & Jørgensen, B.B. 2014: Konkrete opgørelser og erfaringer fra 20 års skovrejsning - med fokus på lokalitet, træart og vækst. Institut for Geovidenskab og Naturforvaltning, Københavns Universitet. IGN Rapport.

Schou, E., Suadicani, K., & Johannsen, V.K. 2015: Carbon Sequestration in Harvested Wood Products (HWP): Data for 2013-Reporting to the UNFCCC, Final Draft. Institut for Geovidenskab og Naturforvaltning, Københavns Universitet. IGN Rapport.

11 Indirect CO₂ and N₂O emissions

11.1 Description of sources of indirect emissions in GHG inventory

The estimation of indirect CO₂ and N₂O emissions is based on the official Danish inventories for the precursor gases (CO, NMVOC, NH₃ and NO_x) reported under the United Nations Economic Commission for Europe (UNECE) Convention on Long-Range Transboundary Air Pollution (CLRTAP) and the CH₄ emissions reported to the UNFCCC.

For an in-depth description of the Danish inventories for the precursor gases, please see the Danish Informative Inventory Report submitted to the UNECE (Nielsen et al., 2022).

11.2 Methodological issues

The activity data used to estimate the emissions of the precursors and hence the indirect emissions are the same as it used to estimate direct greenhouse gas emissions. Therefore, the information provided in Chapters 3-7 on the activity data is valid also for the reporting of the indirect emissions.

The emission factors used to estimate the emissions of the precursors are for CH₄ documented in this report; see Chapter 3-7. For emissions of CO, NMVOC, NO_x and NH₃, the emission factors are based on a very large selection of data sources. All emission factors are documented in the annual documentation report (Informative Inventory Report – IIR) produced by Denmark and reported as part of the reporting commitments under the Convention on Long-Range Transboundary Air Pollution under the United Nations Economic Commission for Europe; see Nielsen et al. (2022).

The structure of the IIR is very similar to the structure of the NIR, so it is easy for interested parties to get the information on the methodologies and emission factors used to estimate emissions of CO, NMVOC, NO_x and NH₃ in Denmark.

Indirect emissions are generally calculated using the methodology described in the 2006 IPCC Guidelines (IPCC, 2006). However, for some sources a more detailed calculation is performed.

The indirect CO₂ emission from CH₄ is calculated as the emission of CH₄ multiplied by 44/16, the indirect CO₂ emission from CO is calculated as the emission of CO multiplied by 44/28 and the indirect CO₂ emission from NMVOC is calculated as the emission of NMVOC multiplied with the carbon content multiplied by 44/12. The default carbon fraction as per the 2006 IPCC Guidelines is 0.6. This fraction is used for all other sources than solvent use, where the inventory is based on a chemical specific approach and hence the exact carbon fraction is known. For more information on the estimation of CO₂ emissions from solvent use, road paving with asphalt and asphalt roofing, please see Chapter 4.5.

In order for consistency with the reporting done by Denmark under the first commitment period of the Kyoto Protocol, the indirect CO₂ emissions from solvent use, road paving with asphalt and asphalt roofing are reported in

category 2D3 of the CRF tables in accordance with the reporting guidelines (UNFCCC, 2013) that allows for the use of these categories in a drop-down list within this category.

For other sources of indirect CO₂, the emissions are reported in CRF Table 6. In the calculation of indirect CO₂, only fossil carbon has been considered, hence indirect CO₂ is not calculated for precursors originating from biomass combustion, nor from other biogenic sources, e.g. agriculture and waste disposal on land. In addition, indirect CO₂ has not been calculated for fuels in the combustion sector where an oxidation factor of 1 is already assumed, i.e. for the IPCC default CO₂ emission factors. Denmark only uses the IPCC default emission factors for fuels with a very low consumption; see Chapter 3 for more information.

The precursor emissions used in the calculation of indirect CO₂ therefore differs from the emissions reported in the CRF. Table 11.1 below shows the precursor emissions on which the calculation of indirect CO₂ is based.

Table 11.1 Emissions of precursors used in the calculation of indirect CO₂ for 2020, kt.

	CH ₄	CO	NM VOC
Energy	4.75	117.72	17.29
Industrial processes and product use	0.01	0.24	0.12

The resulting indirect emissions are shown in Table 11.2 below.

Table 11.2 Indirect CO₂ emissions for 1990 and 2020, kt CO₂e.

	1990	2020
Indirect CO ₂ from solvent use	93.73	69.16
Indirect CO ₂ from road paving with asphalt	0.58	0.88
Indirect CO ₂ from asphalt roofing	0.02	0.02
Indirect CO ₂ from other sources	1119.84	236.75
Total GHG emission excluding all indirect CO ₂	69 907.35	41 438.94
Total GHG emission consistent with CP1	70 001.69	41 509.00

For indirect N₂O the emissions resulting from ammonia emissions in agriculture and LULUCF are covered in the sectoral tables for agriculture and LULUCF. The indirect N₂O emissions resulting from NO_x emissions in these sectors are included in CRF Table 6. The indirect N₂O emissions are calculated using the below equation.

$$N_2O = (NO_x - N + NH_3 - N) * EF * 44/28$$

The default emission factor of 0.1 kg N₂O-N per kg NH₃-N or NO_x-N emitted is used for all sources.

11.3 Uncertainties and time-series consistency

Uncertainties for the precursors are estimated using a simple error propagation method similar to the IPCC Approach 1.

Please see Nielsen et al. (2022) for further information on the uncertainties and time-series consistency for the Danish inventories of indirect greenhouse gases.

11.4 Category-specific QA/QC and verification

Please see Nielsen et al. (2022) for further information on the QA/QC for the Danish inventories of indirect greenhouse gases.

11.5 Category-specific recalculations

A large number of recalculations are carried out annually to take into account new data, updated knowledge, new sources and correction of errors. The recalculations for 1990 and 2019 are shown in Table 11.3 and 11.4 below. Only short explanations are provided in this report as the number of recalculations are vast and it is beyond the scope of this report to include them here.

Please see Nielsen et al. (2022) for further information on the recalculations for the Danish inventories of indirect greenhouse gases.

Table 11.3 Recalculations of indirect emissions and precursors for 1990, kt.

	Source emissions					Indirect emissions	
	CH ₄	CO	NM VOC	NO _x	NH ₃	CO ₂	N ₂ O
Total	-0.06	9.25	2.45	4.77	0.01	16.84	0.02
Energy	0.03	9.02	1.05	4.77	0.00	16.47	0.02
Industrial processes and product use	-	0.23	-0.01	-	0.01	0.37	0.00
Agriculture	-0.09	-	1.40	0.00			0.00
LULUCF	0.00	-	-	-			-
Waste	0.00	0.00	0.00	0.00	-		0.00

The recalculations in 1990 are generally small. For CH₄, the largest recalculation is in the energy and agricultural sector. The recalculations for agriculture do not affect the indirect CO₂ emission, as they are biogenic. For recalculations in the energy sector, please refer to Chapter 3.

The recalculations of CO are small compared to the total CO emission in 1990 (approximately 719 kt). The small recalculations are mainly due to changes in the estimate from non-road machinery. A major revision of the Danish non-road emission model has been made based on new stock data from the Danish motor register for tractors used in agriculture, forestry, industry (building and construction, manufacturing industries) and commercial/institutional non road sectors. The stock data consist of fuel type, new sales year, vehicle weight, engine size and branch registration of each tractor, thus enabling a regrouping of the tractors used into the above mentioned inventory sectors.

The NMVOC emissions have decreased mainly due to recalculations in the energy and agricultural sectors. For agriculture, the recalculation is due to a correction of an error. The recalculation for agriculture do not affect the indirect CO₂ emission, as they are biogenic. For the energy sector, the main recalculation was related to non-road transport as described under CO.

For NO_x, the only major change is related to mobile combustion. The main reason is the mentioned update to the model for non-road mobile combustion. This also affected the CH₄ emission and is documented in Chapter 3.5.

The changes for NH₃ are minor and are not further discussed here.

The total indirect CO₂ emission has decreased slightly as a consequence of the decreasing emissions of CO and NMVOC.

Table 11.4 Recalculations of indirect emissions and precursors for 2019, kt.

	Source emissions				Indirect emissions			
	CH ₄	CO	NMVOC	NO _x	NH ₃	CO ₂	N ₂ O	
Total	2.85	2.51	-0.39	1.78	0.13	3.05	0.01	
Energy	0.00	2.61	0.60	1.68	0.11	3.09	0.01	
Industrial processes and product use	0.00	0.00	0.17	0.00	0.00	-0.04	0.00	
Agriculture	-0.28	0.01	-1.14	0.10			0.00	
LULUCF	0.06	-0.11	-0.01	0.00			0.00	
Waste	3.06	0.00	0.00	0.00	0.01		-0.01	

The main recalculations for CH₄, CO, NMVOC and NO_x in 2019 are to some extent caused by the same improvements as mentioned for 1990, i.e. the update for non-road mobile combustion and for NMVOC the correction in agriculture.

The total indirect CO₂ emission has decreased slightly as a consequence of the decreasing emissions of CH₄ and CO and the smaller increase in NMVOC.

Please see Nielsen et al. (2022) for further information on the recalculations for the Danish inventories of indirect greenhouse gases. For the recalculations of CH₄, please see the relevant sector chapter of this report.

11.6 Category-specific planned improvements

Please see Nielsen et al. (2022) for further information on the planned improvements for the Danish inventories of indirect greenhouse gases.

11.7 References

EEA, 2019: EMEP/EEA air pollutant emission inventory guidebook 2019. Technical guidance to prepare national emission inventories. EEA Report 13/2019. Available at: <https://www.eea.europa.eu/publications/emep-eea-guidebook-2019> (07-02-2021).

IPCC, 2006: 2006 IPCC Guidelines for National Greenhouse Gas Inventories, Prepared by the National Greenhouse Gas Inventories Programme, Eggleston H.S., Buendia L., Miwa K., Ngara T. & Tanabe K. (eds). Published: IGES, Japan. Available at: <http://www.ipcc-nggip.iges.or.jp/public/2006gl/index.html> (07-02-2021).

Nielsen, O.-K., Plejdrup, M.S., Winther, M., Mikkelsen, M.H., Nielsen, M., Gyldenkaerne, S., Fauser, P., Albrektsen, R., Hjelgaard, K., Bruun, H.G. & Thomsen, M., 2022: Annual Danish Informative Inventory Report to UNECE. Emission inventories from the base year of the protocols to year 2020. Aarhus University, DCE - Danish Centre for Environment and Energy. (In press).

UNFCCC, 2013: Decision 24/CP.19 - Revision of the UNFCCC reporting guidelines on annual inventories for Parties included in Annex I to the Convention.

12 Information on accounting of Kyoto units

Referring to Decision 3/CMP.11 on ‘Implications of the implementation of decisions 2/CMP.7 to 4/CMP.7 and 1/CMP.8 on the previous decisions on methodological issues related to the Kyoto Protocol, including those relating to Articles 5, 7 and 8 of the Kyoto Protocol, part I: implications related to accounting and reporting and other related issues’ for the preparation of the information required under Article 7 of the Kyoto Protocol (UNFCCC, 2015), this chapter and chapters 13, 14 and 15 include information and references to the annual supplementary information under the Kyoto Protocol. Decision 3/CMP.11 states that decisions 13/CMP.1, 15/CMP.1, 18/CMP.1 and 19/CMP.1 shall apply *mutatis mutandis*, except where otherwise specified in decisions 1/CMP.8 and 2/CMP.8 and in decision 3/CMP.11.

12.1 Information on transferred or acquired units

In accordance with paragraph 10 of the annex to Decision 15/CMP.1 information on emission reduction units (ERUs), certified emission reductions (CERs), temporary certified emission reductions (tCERs), long-term certified emission reductions (lCERs), assigned amount units (AAUs) and removal units (RMUs) will be reported for the first calendar year in which these units will be transferred or acquired.

12.2 Summary of information reported in the SEF tables

The Standard Electronic Format (SEF) report for 2021 CP1 and CP2 has been submitted to the UNFCCC Secretariat electronically and the contents of the reports can also be found in annex 6.

12.3 Discrepancies and notifications

Annex I parties are *inter alia* required to submit four reports according to paragraphs 12 to 16 of the annex to decision 15/CMP.1. These reports are:

- Paragraph 12 – List of discrepancies identified by the ITL. List not included as no discrepant transactions occurred in 2021.
- Paragraph 13/14 – List of notifications from the CDM Executive Board regarding lCERs. No CDM notifications occurred in 2021.
- Paragraph 15 – List of non-replacement identified by the ITL. No non-replacements occurred in 2021.
- Paragraph 16 – List of invalid Kyoto units. No invalid units exist as of 31 December 2021.

No actions were taken or changes made to address discrepancies for the period under review.

12.4 Publicly accessible information

Information from the SEF available to the public will be included in the Danish SEF report 2021. The report will be available on the Danish Business Authority’s website in addition to other public reports (pursuant to paragraphs 44 to 48 of the annex to Decision 13/CMP.1) as well as in the ETS registry:

In English: <https://danishbusinessauthority.dk/public-information>

In Danish:

<https://erhvervsstyrelsen.dk/offentlig-information-og-persondata>

Link to reports available from the ETS registry:
<https://unionregistry.ec.europa.eu/euregistry/DK/public/reports/publicReports.xhtml>

The reports are updated every month.

The reports include information on each account as required in paragraph 45 of the annex to Decision 13/CMP.1. Please note that publishing the contact information (paragraph 45 (d) and (e)) requires the consent of the account holder according to EU legislation. Thus, this information is not publicly available. The Danish Business Authority complies with the requirements stipulated in the European Commission's Union Registry Regulation, No. 389/2013, concerning the publication of confidential information.

Other information that is required to be publicly available can be found on the EUTL website: <https://ec.europa.eu/clima/ets/>

Information on article 6 projects is not available as Denmark to this date has not approved any Joint Implementation projects in Denmark.

12.5 Calculation of the commitment period reserve

The calculation of the Commitment Period Reserve (CPR) is based on the assigned amount of 269,377,890 tonnes of CO₂ equivalents (UNFCCC, 2017). Subsequently, the CPR calculated as 90 % of the assigned amount is 242,440,102 tonnes CO₂ equivalent, during the commitment period and has not changed since the Report of the review of the initial report of Denmark published on 9 August 2017 (UNFCCC, 2017). The commitment period reserve has not changed since the previous submission, as 100 % times the most recent inventory times eight would amount to a higher value.

12.6 KP-LULUCF accounting

Accounting of KP-LULUCF under the second commitment period of the Kyoto Protocol began with the entering into force of the Doha-Amendment to the Kyoto Protocol. Issuing of units will not commence until a submission has been reviewed and a review report has been published. As of the preparation of the 2022 NIR, a review report has not been published after the Doha Amendment entered into force. Table 12.1 below contains data as submitted under the Kyoto Protocol for the purposes of the Doha Amendment.

Table 12.1 Information on accounting for activities under articles 3.3 and 3.4 of the Kyoto Protocol.

Greenhouse gas source and sink activities	Base year	Net emissions/-removals								Total	Accounting Parameters	Accounting Quantity
		2013	2014	2015	2016	2017	2018	2019	2020			
A. Article 3.3 activities												
A.1. Afforestation and Reforestation		-110.00	-221.21	-287.32	-278.23	-343.14	-484.76	-610.36	-274.99	-2610.01		-2610.01
A.2. Deforestation		70.23	170.68	677.88	563.31	44.74	415.57	213.89	514.67	2670.97		2670.97
B. Article 3.4 activities												
B.1. Forest Management										-21160.24		-23771.31
Net emissions/removals										-21160.24		
Forest management reference level (FMRL)											409.00	
Technical corrections to FMRL											-82.62	
Forest management cap											19822.07	-19822.07
B.2. Cropland Management		5544.77	2422.07	3560.94	2450.75	2610.04	2208.34	3302.01	2994.15	2756.71	22305.01	-22053.14
B.3. Grazing Land Management		2371.07	1810.94	1953.75	1992.16	2117.88	2058.79	2186.44	2152.20	2254.65	16526.81	-2441.75

12.7 References

EC, 2004: COMMISSION REGULATION (EC) No 2216/2004 of 21 December 2004 for a standardised and secured system of registries pursuant to Directive 2003/87/EC of the European Parliament and of the Council and Decision No 280/2004/EC of the European Parliament and of the Council. Available at:

<http://eur-lex.europa.eu/LexUriServ/LexUriServ.do?uri=OJ:L:2004:386:0001:0077:EN:PDF>

UNFCCC, 2015: Report of the Conference of the Parties serving as the meeting of the Parties to the Kyoto Protocol on its eleventh session, held in Paris from 30 November to 13 December 2015. Available at:

<http://unfccc.int/resource/docs/2015/cmp11/eng/08a01.pdf#page=5>

UNFCCC, 2017: Report on the review of the report to facilitate the calculation of the assigned amount for the second commitment period of the Kyoto Protocol of Denmark. Available at: <http://unfccc.int/resource/docs/2017/irr/dnk.pdf>

13 Information on changes in the national system

Since the 2021 submission, no changes have been made to the national system.

14 Information on changes in the National Registry

The ETS operates in the EU Member States plus Iceland, Liechtenstein and Norway. It covers certain GHG emissions from installations such as power stations, combustion plants, oil refineries and iron and steel works, as well as factories making cement, glass, lime, bricks, ceramics, pulp, paper and board. Emissions from aircraft operators performing aviation activities in the EU and EFTA states are also included in the ETS.

The following changes to the National Registry of Denmark have occurred in 2021:

Reporting Item	Description
15/CMP.1 annex II.E paragraph 32.(a) Change of name or contact	<p>The Danish Business Authority The Danish Kyoto Registry Dahlerups Pakhus Langelinie Allé 17 DK-2100 København Ø Telephone 1: +45 3529 1000 Telephone 2: +45 7220 0038 E-mail: co2register@erst.dk</p> <p>https://erhvervsstyrelsen.dk/co2-kvoteregistret</p> <p>https://danishbusinessauthority.dk/eu-ets-registry-and-danish-kyoto-registry</p> <p>The Registry Staff has changed to:</p> <p>Registry Manager Ms. Susanne Petersen Phone: +45 3529 1884 E-mail: susbod@erst.dk</p> <p>Ms. Eydis Ingimundardottir Phone: +45 3529 1817 E-mail: eyding@erst.dk</p> <p>Ms. Betina Elmelund Phone: +45 3529 1182 E-mail: betelm@erst.dk</p> <p>Ms. Kathrine Lindholm Phone: +45 3529 1392 E-mail: katlin@erst.dk</p> <p>Ms. Janni Krolack Phone: +45 35291864 E-mail: jankro@erst.dk</p> <p>Ms. Benét Hermind Phone: +45 3529 1546 E-mail: benhim@erst.dk</p>
15/CMP.1 annex II.E paragraph 32.(b) Change regarding cooperation arrangement	<p>There was a change in the cooperation arrangement during the reported period as the United Kingdom of Great Britain and Northern Ireland no longer operate their registry in a consolidated manner within the Consolidated System of EU registries, CS EUR.</p>
15/CMP.1 annex II.E paragraph 32.(c) Change to database or the capacity of national registry	<p>There has been 6 new EUCR releases (versions 12.4, 13.0.2, 13.2.1, 13.3.3, 13.5.1 and 13.5.2) after version 11.5 (the production version at the time of the last Chapter 14 submission).</p> <p>No changes were applied to the database, whose model is provided in Annex A. No change was required to the application backup plan or to the disaster recovery plan.</p> <p>No change to the capacity of the national registry occurred during the reported period.</p>

Reporting Item	Description
15/CMP.1 annex II.E paragraph 32.(d) Change regarding conformance to technical standards	The changes that have been introduced with versions 12.4, 13.0.2, 13.2.1, 13.3.3, 13.5.1 and 13.5.2 compared with version 11.5 of the national registry are presented in Annex B. It is to be noted that each release of the registry is subject to both regression testing and tests related to new functionality. These tests also include thorough testing against the DES and are carried out prior to the relevant major release of the version to Production (see Annex B). No other change in the registry's conformance to the technical standards occurred for the reported period.
15/CMP.1 annex II.E paragraph 32.(e) Change to discrepancies procedures	No change of discrepancies procedures occurred during the reported period.
15/CMP.1 annex II.E paragraph 32.(f) Change regarding security	No changes regarding security were introduced.
15/CMP.1 annex II.E paragraph 32.(g) Change to list of publicly available information	No change to the registry internet address during the reported period. In English: https://danishbusinessauthority.dk/danish-emission-trading-registry https://danishbusinessauthority.dk/public-information In Danish: https://erhvervsstyrelsen.dk/co2-kvoteregistret https://erhvervsstyrelsen.dk/offentlig-information The content of the publicly available information is updated monthly, and confidential information is clearly marked as confidential. The information is available in English and Danish. No change to the type of publicly available information occurred during the report period. As previously, information concerning transactions, holdings and total volumes via the EUTL is considered confidential. This information is not publicly available before year x+3 ("x" denotes the year of the transaction). Furthermore the following information is considered confidential: <ul style="list-style-type: none"> • Account identifier • Representative's identifier, name, and contact information • Holdings of all accounts • All transactions made • The unique unit identification code of the allowances • The unique numeric value of the unit serial number of the Kyoto units held or affected by a transaction except for the retirement transaction No public information is available concerning article-6 projects as Denmark has not approved any joint implementation projects in the country.
15/CMP.1 annex II.E paragraph 32.(h) Change of Internet address	No change to the registry internet address during the reported period. The URL of the Danish Registry is https://unionregistry.ec.europa.eu/euregistry/DK/index.xhtml
15/CMP.1 annex II.E paragraph 32.(i) Change regarding data integrity measures	No change of data integrity measures occurred during the reported period.
15/CMP.1 annex II.E paragraph 32.(j) Change regarding test results	No change during the reported period.
The previous Annual Review recommendations	The 2020 assessment report included no recommendations for Denmark.

The mentioned Annex A and Annex B contains confidential information and is therefore not part of the NIR.

15 Information on the minimization of adverse impacts in accordance with Article 3, paragraph 14

No changes have occurred since the information reported in NIR 2011.

16 Methodology applied for the greenhouse gas inventory for Greenland

16.1 Introduction

This chapter is Greenland's National Inventory Report (NIR) 2022 for submission to the United Nations Framework Convention on Climate Change and the Kyoto Protocol.

The following sections contain detailed information on Greenland's inventories for all the years from 1990 to 2020. The structure of the report follows the UNFCCC guidelines on reporting and review.

The issues addressed in this report are trends in greenhouse gas emission, a description of each IPCC category, uncertainty estimates, recalculations, planned improvements and procedures for quality assurance and control.

The annual emission inventories for the years 1990-2020 are reported in the Common Reporting Format (CRF) as requested in the reporting guidelines. The CRF-spreadsheets contain data on emissions, activity data and implied emission factors for each year. Emission trends are given for each greenhouse gas and for the total greenhouse gas emission in CO₂ equivalents.

According to the instrument of ratification, the Danish government has ratified the UNFCCC on behalf of Denmark, Greenland and the Faroe Islands. The Danish government has ratified the Kyoto Protocol on behalf of Denmark and Greenland. In the first commitment period under the Kyoto Protocol, Greenland had a reduction commitment. However, for the second commitment period a territorial exemption has been made in the ratification of the Doha Amendment. Hence, in the second commitment period Greenland does not have a commitment.

The information in this chapter relates to Greenland only. Chapter 17 contains information on the aggregated submission of Denmark and Greenland under the Kyoto Protocol.

This report does not contain the full set of CRF Tables. However, the full set of CRF tables is available at the EIONET, Central Data Repository, kept by the European Environment Agency:

http://cdr.eionet.europa.eu/dk/Air_Emission_Inventories/Submission_UNFCCC

The greenhouse gas inventory submitted in 2022 is completed by Statistics Greenland with technical support from the Danish National Center of Environment and Energy (DCE). This report on methodology is written by Statistics Greenland with documental support by DCE.

16.1.1 Greenhouse gas

The greenhouse gases to be reported under the Climate Convention are:

- Carbon dioxide CO₂
- Methane CH₄

- Nitrous Oxide N₂O
- Hydrofluorocarbons HFCs
- Perfluorocarbons PFCs
- Sulphur hexafluoride SF₆
- Nitrogen trifluoride NF₃

According to the IPCC and their Fourth Assessment Report, which UNFCCC has decided to use as reference for reporting inventory years throughout the commitment period 2013-2020, the global warming potentials for a 100-year time horizon are:

- Carbon dioxide (CO₂) 1
- Methane (CH₄) 25
- Nitrous Oxide (N₂O) 298

Based on weight and a 100-year period, methane is thus a 25 times more powerful greenhouse gas than CO₂, and nitrous oxide is 298 times more powerful. Some of the other greenhouse gases (hydrofluorocarbons, perfluorocarbons and sulphur hexafluoride) have considerably higher global warming potential values.

The indirect greenhouse gases reported are nitrogen oxides (NO_x), carbon monoxide (CO), non-methane volatile organic compounds (NMVOC) and sulphur dioxide (SO₂).

16.1.2 A description of the institutional arrangement for inventory preparation

All calculations and reporting in this 2021 submission has been conducted by Statistics Greenland. This includes reporting the Greenlandic national emission inventory to DCE in the Common Reporting Format in accordance with the UNFCCC guidelines.

DCE is responsible for reporting the national inventory for the Kingdom of Denmark to the UNFCCC and for reporting the national inventory under the Kyoto Protocol for both Denmark and Greenland.

The inventory for LULUCF and KP-LULUCF is carried out by DCE and the documentation of the inventory (Sections 16.6 and 16.10) is completed by the Danish LULUCF experts with data supplied by Statistics Greenland.

The work concerning the annual greenhouse gas emission inventory is carried out in cooperation with Greenlandic ministries, research institutes, organisations and companies.

Statistics Greenland

Statistics Greenland conducts an annual energy statistics in a format suitable for the emission inventory work and fuel-use data for the large combustion plants. Since 2009, annual surveys on emissions of F-gas have been conducted.

Agricultural Advisory Service (Ministry for Agriculture, Self-Sufficiency, Energy and Environment)

Background data on forestry, cropland and grassland, and statistics on livestock (sheep and reindeer).

Former Ministry of Nature and Environment

Data on waste and emission of F-gas. Annual Survey carried out by the former Ministry of Domestic Affairs, Nature and Environment until 2008 and by Statistics Greenland from 2009 and onwards.

Greenland Airport Authority (Ministry of Housing and Infrastructure)

Statistics on domestic and foreign flights to and from Greenland.

16.1.3 Brief description of the process of inventory preparation - data collection, data processing, data storage

The background data (activity data and emission factors) for estimation of the Greenlandic emission inventories is collected and stored in central databases at Statistics Greenland. The databases are in SAS/WPS format and handled with the World Programming System (WPS) software. The WPS programs are designed by Statistics Greenland. The methodologies and data sources used for the different sectors are described briefly in Section 16.1.4 and more in depth in Sections 16.3 to 16.7 and Section 16.10.

For each submission, databases and additional tools and submodels are frozen together with the resulting CRF-reporting format. The material is placed on servers at Statistics Greenland. The servers are subject to routine backup services. Material, which have been backed up is archived safely.

16.1.4 Brief general description of methodologies and data sources used

Greenland's air emission inventories are based on the IPCC Guidelines for National Greenhouse Gas Inventories (IPCC, 2006), the Good Practice Guidance and Uncertainty Management in National Greenhouse Gas Inventories (IPCC, 2000), the Good Practice Guidance for Land Use, Land-Use Change and Forestry (IPCC, 2003) and the CORINAIR methodology.

CORINAIR (COoRdination of INformation on AIR emissions) is a European air emission inventory programme for national sector-wise emission estimations, harmonised with the IPCC guidelines. To ensure estimates are as timely, consistent, transparent, accurate and comparable as possible, the inventory programme has developed calculation methodologies for most subsectors and software for storage and further data processing (EMEP/CORINAIR, 2007).

A thorough description of the CORINAIR inventory programme used for Danish emission estimations is given in Illerup et al. (2000). The CORINAIR calculation principle is to calculate the emissions as activities multiplied by emission factors. Activities are numbers referring to a specific process generating emissions, while an emission factor is the mass of emissions per unit activity. Information on activities to carry out the CORINAIR inventory is largely based on official statistics. The most consistent emission factors have been used either as national values or as default factors proposed by international guidelines.

A list of all subsectors at the most detailed level is given in Illerup et al. (2000) together with a translation between CORINAIR and IPCC codes for sector classifications.

The greenhouse gas inventory for Greenland includes the following sectors:

- Energy
- Industrial Processes and Product Use

- Agriculture
- Land Use, Land-use Change and Forestry
- Waste
- KP LULUCF

The applied methodologies follow the IPCC Guidelines and IPCC Good Practice Guidance. In some cases the methodology is identical to the methodology applied in the Danish inventory, however, the availability of data – especially site specific data – do not allow the same methodology to be used for all the sectors. The brief methodological description is included below for the different sectors. Descriptions that are more thorough are included in Sections 16.3-16.7 and 16.10.

Energy

Fuel Combustion

The Greenlandic emission inventory for fuel combustion has been performed according to the IPCC tier 1 methodology. The inventory is based on activity data from the Greenlandic energy statistics and on emission factors for different fuels, plants and sectors.

Total fuel combustion is based on data from Polaroil, Air BP (earlier Statoil) and Malik Supply A/S. Polaroil imports fuel and distributes fuel in all parts of Greenland. Air BP imports and distributes fuel in Kangerlussuaq. Malik Supply A/S, a Danish company, re-distributes fuel bought from Polaroil to Greenlandic trawlers, ships etc. By using detailed data from Polaroil, Statoil and Malik Supply A/S it is possible to determine total import, total export, total international bunkers and total domestic fuel combustion.

Total domestic fuel combustion is divided into sectors and private households by using data from a survey on energy consumption, company specific sales data from Polaroil and local fuel distributors, relevant tax accountings and by estimation.

Fuel combustion in private households is estimated using detailed information from a number of local fuel distributors. Fuel deliveries are registered by buildings. In Greenland, each building has a unique number registered in the Greenlandic Area Register (NIN). By combining the NIN-register and the Danish Business Register (CVR) with statistics on housing and population, each building is labelled *private household* or located to a sector describing the main activity in the building. This new building-sector register, completed annually, is used extensively to determine the buyer of fuel delivered by Polaroil or local fuel distributors.

Fuel combustion in road traffic is based on a model designed by Statistics Greenland. The model contains data on the vehicle stock obtained from the Greenland Police Department's register on engine data. The vehicles are divided into broad categories of type i.e. personal car, lorry, taxi, truck, ambulance, motorbike etc. Each category is assigned with ratios on fuel type and mileage. Input data on mileage is derived from an annual survey among businesses and private road traffic since 2008. Each vehicle is divided in business categories or labelled *private vehicle* according to the owner. For each group the emissions are estimated by combining vehicle and annual mileage numbers with standard emission factors according to the type of fuel. However, the model does not take cold start or hot engines into account.

For air traffic annual emissions are based on activity data from Air Greenland A/S and sales data from the Greenland Airport Authority. For navigation, ferries and freight, annual emissions are based on activity data from Royal Arctic Line A/S (freight), Royal Arctic Tankers A/S (freight), and Arctic Umiaq Line A/S (passengers).

For further information please refer to Section 16.3.

Memo Items

International Aviation Bunkers

Previously, emissions from international aviation bunkers have been considered to be of negligible importance in terms of Greenland. For that matter the annual amount of jet fuel loaded into foreign aircrafts has been included as part of the IPCC category 1A3a Domestic Aviation. However, some misunderstanding has taken place and this assumption seems to be incorrect! New data has emerged regarding the distinction between domestic and international flights, and it seems possible that combustion of jet fuel in international bound aircrafts taking off from Greenland can be determined and reported as international aviation bunkers as from the coming 2023 submission. However, in this 2022 submission jet fuel loaded into foreign aircrafts is still included as part of the IPCC category 1A3a Domestic Aviation.

International Navigation Bunkers

Emissions from international marine bunkers are included from 2004 and onwards. Before 2004, international marine bunkers are considered to be of negligible importance.

Fugitive emissions

Greenland has no coal mines, no off-shore activities, no oil refineries, no natural gas transmission or distribution. For that reason, there have been no fugitive emissions from such activities in 1990-2009. However, in 2010 a Scottish company initiated a search for oil along the westcoast of Greenland. Three wells were drilled and tested in 2010. Five wells in 2011. There has been no oil exploration since 2011.

In the 2014 National Inventory Report calculation of fugitive emission was based on the annual number of drilled and tested wells and IPCC Guideline emission factors. Since the 2015 National Inventory report fugitive emission is to be based on the amount of drilled oil and gas and IPCC Guideline emission factors.

However, the Scottish company has not been able to provide the Government of Greenland with any information on the amount of oil and gas picked up during drillings in 2010 and 2011. To our knowledge, the Scottish company only discovered a few minor kicks with some minor inflow of water or gas during drillings.

With no data available, activity data in 2010 and 2011 has been marked with the notation key Not Applicable (NA). Since no amounts could be estimated, all fugitive emissions are assumed to be zero, and also marked with the notation key Not Applicable (NA). This decision has been made in agreement with the DCE.

Aside from energy production, some fugitive emission occurs in the distribution of fuel e.g. when refuelling from ships to on-shore tanks, onshore loading of fuel to ships and offshore loading of ships. The emission would only be in

the form of NMVOC. The fugitive emission from loading/unloading of ships is currently not estimated.

Industrial Processes and Product Use

Mineral Industry

CO₂ emissions occur from limestone and dolomite use. Import statistics of limestone are used as activity data for estimating the emissions.

Chemical Industry

Greenland has no chemical industry.

Metal Industry

Greenland has no metal industry.

Non-energy Products from Fuels and Solvent Use

CO₂ emissions occur from paraffin wax use, road paving with asphalt and asphalt roofing. Import statistics of paraffin wax and asphalt are used as activity data for estimating the emissions.

The emission estimates for solvent use are also prepared by using import statistics of pure chemicals that fits the criteria for being considered a NMVOC compound. Additionally, import statistics are used for products containing NMVOC's. The NMVOC emission is then calculated in to a CO₂ emission by using a standard value for carbon content in the NMVOC's. For further information, see Section 16.4.

Electronics Industry

Greenland has no electronics industry.

Product Uses

Greenland has no production of halocarbons or SF₆. Data on consumption of F-gas (HFCs and SF₆) are obtained from an annual survey on consumption of halocarbons and SF₆ conducted by the Ministry of Industry and Labour. Information on emission of industrial gases is available from 1995 onwards. Greenland has no consumption of PFCs.

Product Uses as Substitutes for ODS

Consumption of halocarbons for refrigeration

Other Product Manufacture and Use

Consumption of SF₆ in electrical equipment.

Other Production

There are several manufacturers of fish products and one tannery. Emissions of NMVOC are estimated, but there are no emissions of greenhouse gases occurring.

For further information on the methodology for calculating emissions from industrial processes, please refer to Section 16.4.

Agriculture

Livestock, Enteric Fermentation and Manure Management

Agriculture is sparse in Greenland due to climatic conditions. However, sheep and reindeer are considered to contribute to emission of greenhouse gases. Enteric fermentation and manure management is assumed to contribute to

emission of CH₄, and nitrogen excretion is assumed to contribute to emission of N₂O.

Activity data for livestock is on a one-year average basis from the agriculture statistics published by Statistics Greenland. Data concerning the land use and crop yield is obtained from the Agricultural Advisory Service.

Data concerning the feed consumption and nitrogen excretion from sheep is based on information from the Agricultural Advisory Service supplemented by data on imported feed. Data concerning the feed consumption and nitrogen excretion from reindeer is based on information from the Agricultural Advisory Service and information from an article on reindeer management in Greenland.

Emission of N₂O is closely related to the nitrogen balance. Thus, quite a lot of the activity data is related to the calculation of ammonia emission. National standards are used to estimate the amount of ammonia emission. When estimating the N₂O emission the IPCC standard value is used for all emission sources. The emission of CO₂ from Agricultural Soils is included in the LU-LUCF sector.

For a more thorough description of the methodology for the agricultural sector, please refer to Section 16.5.

Land Use, Land-Use Change and Forestry

Greenland is the world's largest non-continental island on the northern American continent between the Arctic Ocean and the North Atlantic Ocean, northeast of Canada. The northernmost point of Greenland, Cape Morris Jesup, is only 740 km from the North Pole. The southernmost point is Cape Farewell, which lies at about the same latitude as Oslo in Norway. Greenland is covering approx. 2,166,086 km². It has been estimated that 81 % is covered permanently with ice leaving only 410,449 km² ice free. The climate is Arctic to sub arctic with cool winters and cold summers. The capital Nuuk is having an average temperature of 1.4°C.

Due to its cold climate the LULUCF sector is of minor importance in relation to the emission of green house gases. Only a very minor area is covered by forest of which the major part has been planted within the last 40 years. Cropland was introduced in year 2000 and grassland management within the last 30 years. The cold climate slows down the biological processes making all growth rates very low.

In total, the emission from the LULUC sector in 2020 has been estimated to a net source of 1.34 kt CO₂ equivalent or 0.2 % of the total Greenlandic emission.

Forest land

Greenland has a few forests, which may qualify to the FAO criteria of forest definitions. The major forest areas are:

A natural forest in the Qinngua valley of 45 ha consisting mainly of *Betula Pubescens* ssp. *Czerepanovii*, which in the period 1990 to 2020 has had an average height of six meters and approx. 100 trees per ha. It is thus assumed that it has had the same biomass for the whole period.

An additional 187 ha other planted forest. The largest of this is an arboretum (a research area) where different species and origins of trees are investigated which are adaptable to the harsh climate.

Cropland

In 1990, no annual crops were grown in Greenland. In 2020, 10.5 ha of cropland were used for annual crops. The primary production is potatoes. Potato fields are mainly managed by hand and primarily fens with a high content of organic matter, which is used for this purpose. It is thus assumed that the IPCC standard emission factor for boreal/cold areas of five tonnes C pr ha can be used although it is probably an overestimation due to the cold climate and the current management practice.

Grassland

In total is 242,000 hectare reported as grassland. The grassland is located in mountainous areas used for grazing of sheep. Due to the global warming, there are some smaller areas, which have become improved fertilised grassland. The total area with improved grassland has increased from 490 ha in 1990 to 1,166 ha in 2020.

Wetlands

Reported area with wetlands consists only of water-reservoirs. Due to lack of methodology for methane emissions under arctic conditions, no emission estimates have been made, which is in accordance with the IPCC Good Practice Guidance guidelines.

Settlements

The few settlements are mainly built on cliffs with very sparse vegetation. Hence, it is assumed that no changes in C stock occur.

Other land

No emission estimates has been made since no data is available which is in accordance with IPCC Good Practice Guidance guidelines.

Harvested wood products

Due to an only marginal area with slowgrowing forests it is assumed that no national changes in the carbon stock in Harvested Wood Products (HWP) have taken place.

For a more thorough description of the methodology applied for LULUCF and KP-LULUCF please refer to Section 16.6 and 16.10.

Waste

Solid Waste Disposal

The solid waste disposal in Greenland can be divided in the following processes:

- Managed waste disposal sites, anaerobic.
- Unmanaged waste disposal sites.

Biological Treatment of Solid waste

Greenland has no biological treatment of solid waste.

Incineration and Open Burning of Waste

Waste incineration with or without energy recovery and open burning of waste is both divided in the following processes:

- Waste incineration/Open burning, biogenic.
- Waste incineration/Open burning, non-biogenic.

Waste incineration with energy recovery is according to IPCC Guidelines included under the energy sector.

Information on amount of waste produced per year, amount of waste treated in the different processes, distribution between household and commercial waste, composition of the household waste and commercial waste, respectively, are provided by the Ministry of Environment and Nature.

Wastewater Treatment and Discharge

N₂O emission from human sewage is estimated. The calculation of the N₂O emission uses population data from Statistics Greenland website and an estimate for average protein consumption combined with default values from the IPCC Guidelines. No emissions of CH₄ are assumed to occur.

For more information, please refer to Section 16.7.

KP-LULUCF

Regarding the possibility of including in the second commitment period emissions and removals associated with land use, land-use change and forestry activities under Article 3.4 of the Kyoto Protocol, Greenland as part of the Kingdom of Denmark has included emissions and removals from forest management (FM), cropland management (CM) and grazing land management (GM).

The national system has identified land areas associated with the activities under Article 3.4 of the Kyoto Protocol in accordance with definitions, modalities, rules and guidelines relating to land use, land-use change and forestry activities under the protocol. All land converted from other activities into Cropland and Grassland is accounted for. No land has been allowed to leave elected areas under Article 3.4, see Section 16.10 for further details.

16.1.5 Brief description of key categories

A key category analysis (KCA) for year 1990 and 2020 has been carried out in accordance with the IPCC Good Practice Guidance.

The categorisation used results in a total of 39 categories. In the level KCA for the inventory for 1990, five key categories were identified. In the KCA for 2020, seven categories were identified as key categories due to the level whereas nine categories were key categories due to the trend.

Of the seven key sources due to level for the reporting year 2020 five are in the energy sector, of which CO₂ from liquid fuels excluding transport in the analysis contributes most with 74.9 % of the national total (this contribution and the percentage contributions in the following are results from the level KCA based on the absolute values of the emissions; this contribution as percentages may differ somewhat from the percentage used in the sectoral chapters). Of the remaining level key categories in the energy sector three are CO₂ from the transport sector and one is CO₂ from combustion of other fuels excluding transportation. Road transportation, domestic aviation and domestic navigation comprise respectively 6.8 %, 4.7 % and 4.5 % of the national total. The last two key categories are HFCs from the consumption of HFCs and CH₄ from enteric fermentation.

The trend assessment shows that N₂O from wastewater treatment and discharge, CO₂ from incineration and open burning of waste and CO₂ from grassland remaining grassland are key categories to the trend. Further five sources from the energy sector are also key categories to the trend as well as HFCs from the consumption of HFCs.

The categorisation used, results, etc. are included in Section 16.11 (Annex 1).

16.1.6 Information on QA/QC plan including verification

A number of measures are in place to ensure the quality of the Greenlandic greenhouse gas inventory.

The general QC activities include:

- Check that data are correctly moved between data processing steps, e.g. it is ensured that the data are imported correctly from the emission spreadsheets/databases to the CRF Reporter.
- The time series are analysed. Any large fluctuations are investigated and explained/corrected.
- The recalculations are analysed and the consistency of the emission estimates are verified.
- The completeness of the inventory is checked utilising the completeness checker incorporated in the CRF Reporter as well as expert knowledge from the inventory compilers.
- All references are checked and it is ensured that the citations are correct.

These types of QC checks are recommended as tier 1 QC checks in the IPCC Good Practice Guidance (IPCC, 2000).

The Greenlandic emission inventory is reviewed by Danish emission experts, who provide input to the Greenlandic inventory compilers on necessary improvements etc. This is done as a QA procedure. When the emission estimates are transferred to DCE, the quality control system of the Danish emission inventory is applied to the Greenlandic data.

All information related to the Greenlandic emission estimates are documented and archived securely annually. This is done in order to ensure that any part of the inventory can be reproduced at a later stage if necessary.

In addition, source specific QA/QC activities are conducted; please see the associated paragraphs in the sectoral chapters.

16.1.7 General uncertainty evaluation

The uncertainty estimates are based on the Tier 1 methodology in the IPCC 2006 Guidelines (IPCC, 2006). Uncertainty estimates for the following sectors are included in the current year: fuel combustion, industrial processes and product use, solid waste, wastewater treatment and waste incineration, agriculture and LULUCF.

The uncertainties for the activity rates and emission factors are shown in Table 16.1.4. The estimated uncertainties for total GHG and for CO₂, CH₄, N₂O and F-gases are shown in Table 16.1.3. The base year for F-gases is 1995 and for all other sources, the base year is 1990. The total Greenlandic GHG emission is estimated with an uncertainty of ± 4.4 %. The trend in the GHG emission (since

1990) has been estimated to be $-11.7 \% \pm 3.6$ %-age points. The GHG uncertainty estimates do not take into account the uncertainty of the GWP factors.

With regard to uncertainty the largest sources in the Greenlandic GHG Inventory are CO₂ and N₂O from liquid fuels in fuel combustion, N₂O emission from waste water treatment, CH₄ emission from enteric fermentation, CH₄ emission from solid waste disposal and HFC from consumption of HFC. However, the result is skewed by the fact that more than 90 % of the Greenlandic Greenhouse gas emission is from fuel combustion of liquid fuels.

Table 16.1.3 Uncertainties 1990-2020.

	Uncertainty [%]	Trend [%]	Uncertainty in trend [%-age points]
GHG	± 4.4	-11.7	± 3.6
CO ₂	± 3.5	-13.8	± 3.6
CH ₄	± 55.8	-11.6	± 8.9
N ₂ O	± 116	-10.0	± 23.5
F-gases	± 51	+19 101	$\pm 7 385$

Table 16.1.4 Uncertainty rates for each emission source.

IPCC Source category	Gas	Base year	Year t	Activity data	Emission factor
		emission	emission	uncertainty	uncertainty
		Gg CO ₂ eqv.	Gg CO ₂ eqv.	%	%
1A Liquid fuels	CO ₂	620	524	3	2
1A Municipal waste	CO ₂	2	9	3	25
1A Liquid fuels	CH ₄	1	1	3	100
1A Municipal waste	CH ₄	0	0	3	100
1A Biomass	CH ₄	0	0	3	100
1A Liquid fuels	N ₂ O	2	2	3	500
1A Municipal waste	N ₂ O	0	0	3	500
1A Biomass	N ₂ O	0	0	3	200
1B2 Oil exploration	CO ₂	0	0	3	1000
1B2 Oil exploration	CH ₄	0	0	3	1000
1B2 Oil exploration	N ₂ O	0	0	3	1000
2A4 Limestone and dolomite use	CO ₂	0	0	5	5
2D2 Paraffin wax use	CO ₂	0	0	5	25
2D2 Paraffin wax use	N ₂ O	0	0	5	25
2D2 Paraffin wax use	CH ₄	0	0	5	25
2D3 Solvent use	CO ₂	0	0	5	25
2D3 Road paving with asphalt	CO ₂	0	0	5	25
2D3 Road paving with asphalt	CH ₄	0	0	5	25
2D3 Asphalt roofing	CO ₂	0	0	5	25
2F Consumption of HFC	HFC	0	13	10	50
2G Consumption of SF ₆	SF ₆	0	0	10	50
3A Enteric Fermentation	CH ₄	8	6	10	100
3B Manure Management	CH ₄	0	0	10	100
3B Manure Management	N ₂ O	1	1	10	100
3D Agricultural soils	N ₂ O	1	2	20	50
3G Liming	CO ₂	0	0	5	50
4A Forest	CO ₂	0	0	5	50
4A Forest	CH ₄	0	0	5	50
4A Forest	N ₂ O	0	0	5	50
4B Cropland	CO ₂	0	0	5	50
4C Grassland	CO ₂	0	1	5	50
4C Grassland	CH ₄	0	0	5	50
5A Solid Waste Disposal	CH ₄	5	5	10	100
5C Incineration and open burning of waste	CO ₂	3	3	10	25
5C Incineration and open burning of waste	CH ₄	3	2	10	50
5C Incineration and open burning of waste	N ₂ O	1	1	10	100
5D Wastewater treatment and discharge	N ₂ O	7	5	30	100

16.1.8 General assessment of completeness

The present Greenlandic greenhouse gas emission inventory includes all major sources identified by the Revised IPCC Guidelines.

16.1.9 References

Ministry of Environment and Nature: Data on waste and ozone depleting substances and greenhouse gases HFCs, PFCs and SF₆ (1995-2008).

Agricultural Advisory Service: Statistics on livestock (sheep and reindeer) and background data on land use (cropland and grassland).

Ministry of Fisheries and Hunting and the Greenlandic Arboretum: Background data for Forestry.

EMEP/CORINAIR, 2007: EMEP/CORINAIR Atmospheric Emission Inventory Guidebook – 2007, prepared by the UNECE/EMEP Task Force on Emissions Inventories and Projections. Technical Report No 16/2007. Available at:

<http://www.eea.europa.eu/publications/EMEPCORINAIR5> (07-02-2021).

EEA, 2019: EMEP/EEA air pollutant emission inventory guidebook 2019. Technical guidance to prepare national emission inventories. EEA Report 13/2019. Available at:

<https://www.eea.europa.eu/publications/emep-eea-guidebook-2019> (07-02-2021).

Illerup, J.B., Lyck, E., Winther, M. & Rasmussen, E. 2000: Denmark's National Inventory Report – Submitted under the United Nations Framework Convention on Climate Change. Emission Inventories. Research Notes from National Environmental Research Institute, Denmark no. 127, 326 pp. Available at:

http://www.dmu.dk/1_viden/2_Publikationer/3_arbrapporter/rapporter/ar127.pdf

IPCC, 2000: Penman, J., Kruger, D., Galbally, I., Hiraishi, T., Nyenzi, B., Emmanuel, S., Buendia, L., Hoppaus, R., Martinsen, T., Meijer, J., Miwa, K. & Tanabe, K. (Eds). Good Practice Guidance and Uncertainty Management in National Greenhouse Gas Inventories. Published: IPCC/OECD/-IEA/IGES, Hayama, Japan. Available at:

<http://www.ipcc-nggip.iges.or.jp/public/gp/english/> (15-04-2007).

IPCC, 2006: 2006 IPCC Guidelines for National Greenhouse Gas Inventories, Prepared by the National Greenhouse Gas Inventories Programme, Eggleston H.S., Buendia L., Miwa K., Ngara T. & Tanabe K. (eds). Published: IGES, Japan. Available at:

<http://www.ipcc-nggip.iges.or.jp/public/2006gl/index.html> (21-02-2014)

IPCC, 2007: Climate Change 2007. The Physical Science Basis. Contribution of Working Group I to the Fourth Assessment report of the Intergovernmental Panel on Climate Change [Solomon, S., D. Qin, M. Manning, Z.Chen. M. Marquis, K.B. Averyt, M. Tignor & H.L. Miller (eds.)]. Cambridge University Press, Cambridge, United Kingdom and New York, NY, USA 996 pp.

Rasmussen, H.E., 1992: Reindeer Management in Southern Greenland (1992). Published in Danish as "Den sydgrønlandske rendrift" (1992).

Statistics Greenland: Energy Consumption in Greenland 2020 published in Danish. Available at:

<https://stat.gl/publ/da/EN/202102/pdf/2020%20Gr%C3%B8nlands%20energiforbrug.pdf> as "Grønlands energiforbrug 2020" in Danish only (13-12-2021).

Statistics Greenland, 2021: The Greenlandic energy statistics aggregated to SINK categories. Not published.

Statistics Greenland, 2021: Data on waste and ozone depleting substances and greenhouse gases HFCs, PFCs and SF₆ (2009-2020).

16.2 Trends in Greenhouse Gas Emissions

16.2.1 Description and interpretation of emission trends for aggregated greenhouse gas emission

The GHG emissions are estimated according to the IPCC guidelines and are aggregated into five main sectors; Energy incl. Transport, Industrial Processes and Product Use, Agriculture, LULUCF, and Waste, see Figure 16.2.3 and Figure 16.2.4.

The greenhouse gases include CO₂, CH₄, N₂O, HFCs, PFCs and SF₆. However, Greenland has no consumption of PFC. In 2020 total emission of greenhouse gases excluding LULUCF was 575.35 Gg CO₂ equivalent, and 576.69 Gg CO₂ equivalent including LULUCF.

Figure 16.2.1 shows total greenhouse gas emission in CO₂ equivalents from 1990 to 2020. The emissions are not corrected for temperature variations. CO₂ is the most important greenhouse gas. In 2020 CO₂ contributed to the total emission in CO₂ equivalent excluding LULUCF with 93.4 %, followed by CH₄ with 2.5 %. N₂O and F-gases (HFCs and SF₆) contributed with 1.9 % and 2.2 %.

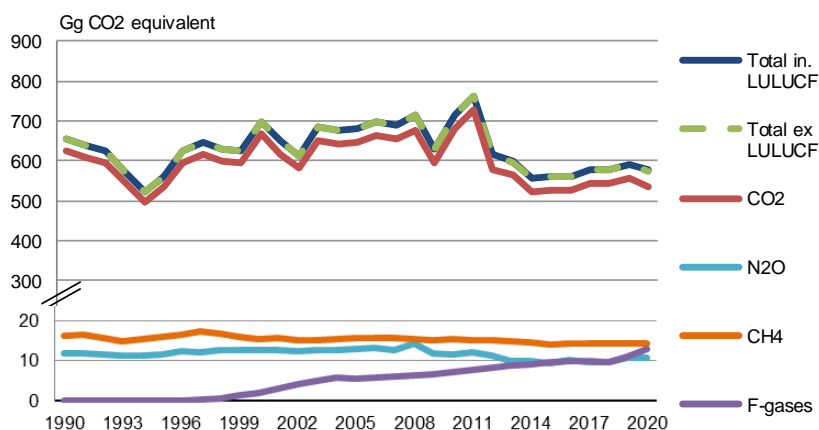

Figure 16.2.1 GHG- emission in CO₂ equivalents, time series 1990-2020.

Stationary combustion plants and transport represent the largest categories. Energy excluding transport contributed to the total emission in CO₂ equivalents excluding LULUCF with 77.1 % in 2020; see Figure 16.2.2. Transport contributed with 16.2 %. Industrial processes and product use, agriculture and waste contributed to the total emission in CO₂ equivalents all together with 6.7 %.

The net CO₂ emission forestry etc. is 0.2 % of the total emission in CO₂ equivalents in 2020. Total GHG emission in CO₂ equivalents excluding LULUCF has decreased by 11.9 % from 1990 to 2020 and decreased 11.7% including LULUCF. Comments on the overall trends etc. seen in Figure 16.2.1 and Figure 16.2.2 are given in the sections below on the individual greenhouse gases.

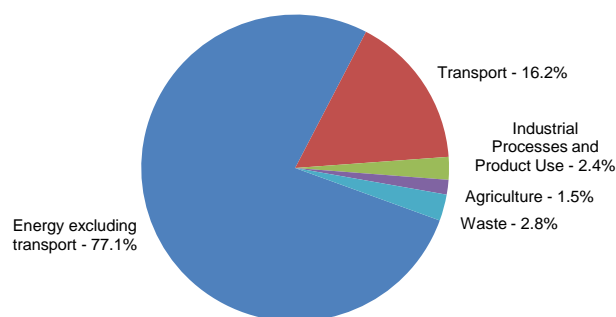

Figure 16.2.2 GHG- emission in CO₂ equivalents distributed on main sectors for 2020.

16.2.2 Description and interpretation of emission trends by gas

Carbon Dioxide

Emission of CO₂ accounted for 93.4 % of the total GHG emission in 2020. The largest source to emission of CO₂ is the energy sector comprising Fuel Combustion (Sectoral Approach). In 2020, the energy sector contributed to 99.2 % of the total CO₂ emission.

In Figure 16.2.3 and Figure 16.2.4 CO₂ emissions are split into several subcategories i.e. Energy Industries, Manufacturing Industries and Construction, Transport, Other energy sectors consisting of the subcategories Commercial and Institutional, Residential, Agriculture and Fishing. All remaining sectors are included in the subcategory *Other* including Agriculture, Industrial Processes and Product Use, and Incineration and Open Burning of waste.

The largest source to the emission of CO₂; the energy sector includes combustion of fossil fuels like gasoil, gasoline, jet kerosene etc. From this sector Agriculture, Forestry and Fisheries (AFF) contributes with 27.9 % making AFF the largest contributor in 2020 followed by Residential 20.2 %, Energy Industries 18.3 % and Transport 17.1 %.

Emissions from Energy Industries have been reduced a great deal in later years due to massive investments in hydro power plants. However, in 2010 and 2011 oil explorations were initiated along the west coast increasing fuel combustion and thus caused emissions in the Energy Industries to rise to the highest point ever. Since 2011, there has been a standstill in the oil exploring activities; see the blue curve in Figure 16.2.3.

Commercial and Institutions contributes with 9.6 % of the total CO₂ emission and Manufacturing Industries and Construction with 5.5 %. The category *Other* (containing the remaining sectors) contributed with 1.6 % of the CO₂ emissions in 2020.

Overall CO₂ emissions excluding LULUCF decreased by 3.3 % from 2019 to 2020. In 2020, the actual CO₂ emission was 14.0 % lower than the emission in 1990 excluding LULUCF.

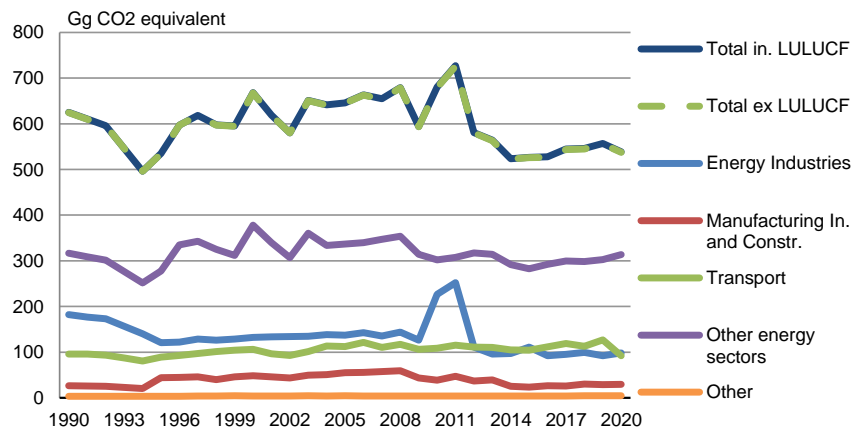

Figure 16.2.3 CO₂ emissions, time series for 1990-2020.

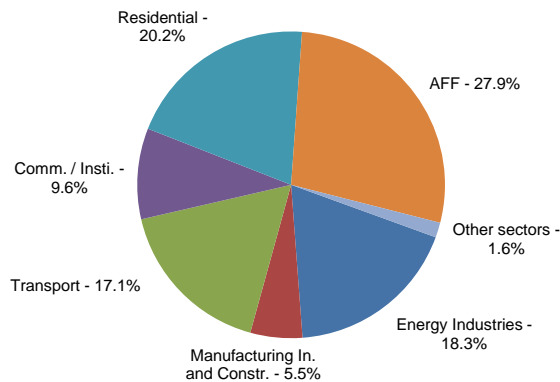

Figure 16.2.4 CO₂ emissions, distribution according to the main sectors for 2020.

Nitrous oxide

Waste, particularly waste water treatment and discharge is the most important N₂O emission source in 2020 contributing 53.9 % to the total N₂O emissions, see Figure 16.2.6. Agricultural activities contributed 23.0 % to the total N₂O emissions in 2020. Fuel combustion including transport contributed 23.1 %. Since 1990, total emission of N₂O has decreased by 9.6 % excluding LULUCF.

Besides from a temporary increase in 2011 total N₂O emission has mostly been reduced in later years, 2009-2010 and 2011-2015 due to a fall in the amount of waste water from industrial fishing plants and reduced use of inorganic fertilisers in agricultural activities, see Figure 16.2.5.

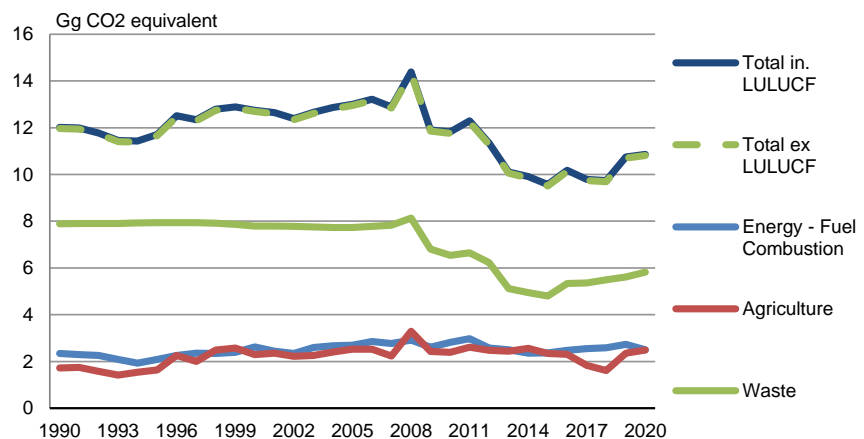

Figure 16.2.5 N₂O emissions, time series for 1990-2020.

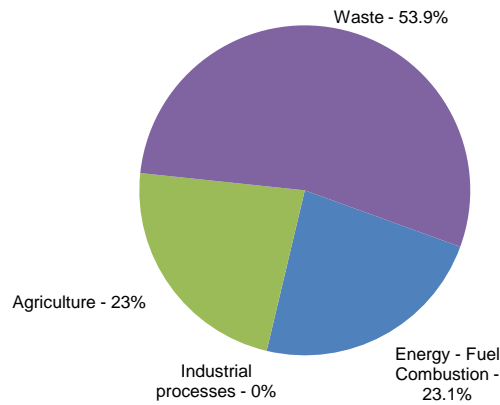

Figure 16.2.6 N₂O emissions, distribution according to the main sectors in 2020.

Methane

The largest sources of anthropogenic CH₄ emissions are waste handling activities contributing with contributing with 46.4 % of total CH₄ emission in 2020, see Figure 16.2.8. Agriculture contributes to 44.6 % of total emission and the energy sector with 9.0 % of total CH₄ emission in 2020.

The emission from agriculture derives from enteric fermentation (97.6 %) and management of animal manure (2.4 %). Since 1990, the number of sheep and reindeer has decreased. From 1990 to 2020, the emission of CH₄ from agricultural activities has decreased by 17.8%.

The emission of CH₄ from waste derives from solid waste disposal (70.9 %) and incineration and open burning (29.1 %). From 1990 to 2020, the emission of CH₄ from solid waste disposal has increased by 4.1 %, while emissions from waste incineration have decreased by 27.7 %. Overall emission of CH₄ from waste handling has decreased by 7.7 % from 1990 to 2020.

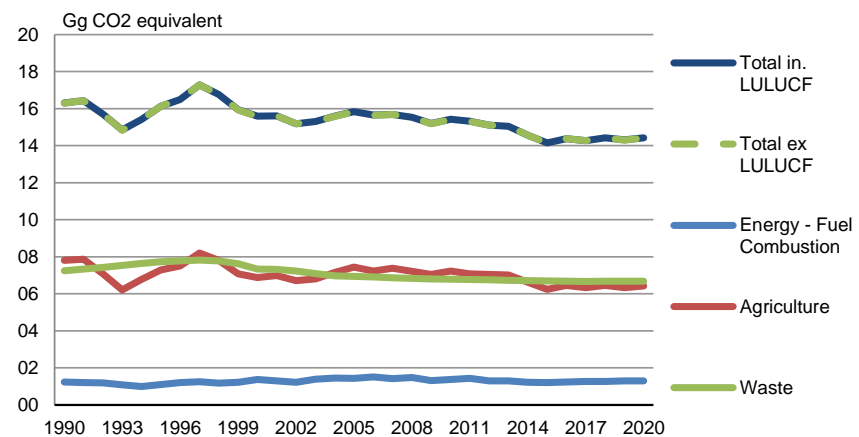

Figure 16.2.7 CH₄ emissions, time series for 1990-2020.

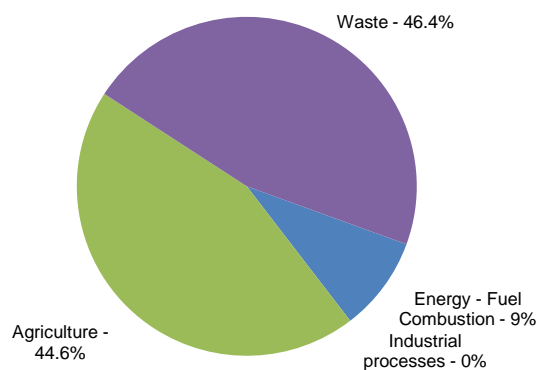

Figure 16.2.8 CH₄ emissions, distribution according to the main sectors in 2020.

HFCs, PFCs and SF₆

This part of the Greenlandic inventory only comprises a full data set for HFCs and SF₆ from 1995. Greenland has no consumption that leads to emission of PFCs. Since 1995 there has been a continuous and substantial increase in the contribution from F-gases calculated as the sum of emissions in CO₂ equivalents, see Figure 16.2.9.

This increasing emission from 1995 to 2020 is caused by an increase in the emission of HFCs. For the years 2004-2020, the relative increase is lower than for the years 1995 to 2004. The increase from 1995 to 2004 is 8,517 %. From 2004 to 2020 total emission increased by 122.8 %. SF₆ contributed to the F-gas sum in 1995 with 50.9 %. Environmental awareness and regulation of this gas under Danish law has reduced its use considerably since 1995. In 2020, the contribution from SF₆ to the emission of F-gases was only 0.02 %.

The use of HFCs has increased to a great extent. Today HFCs are by far the dominant F-gas, comprising 49.1 % in 1995, but 99.98 % in 2020. HFCs are mainly used as a refrigerant.

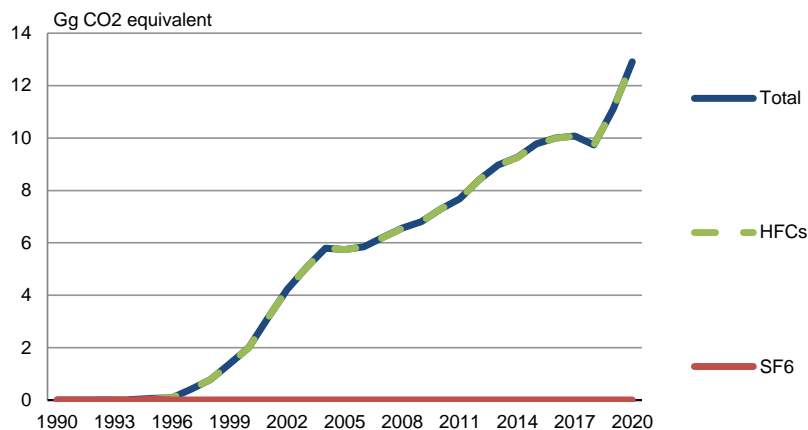

Figure 16.2.9 F-gas emissions, time series for 1990-2020.

16.2.3 Description and interpretation of emission trends by category

Energy

The emission of CO₂ from energy has decreased by 14.2 % from 1990 to 2020. Emissions decreased from 1990 until 1994 due to the implementation of the first hydro power plant. However, since 1994 combustion of fuel increased continuously causing emissions to increase as well. The reason for this increase was primarily higher demand for transportation and heating. Combustion of fuel may decrease in certain years due to milder temperatures. However, in 2010 and 2011, emissions increased significantly due to the initiation of

oil exploration, which caused CO₂ emission from energy to rise abruptly in 2010 and 2011. However, since 2011 oil exploration activities came to a standstill. At the same time, Greenland's fifth hydro power plant went into operation. In later years, the increasing supply in hydro power has led to a decrease in CO₂ emissions from energy.

Overall emission of CH₄ from energy has increased by 4.6 % from 1990 to 2020. However, emission of CH₄ from transportation has increased by 94.9 % from 1990 to 2020, mainly due to an increase in domestic aviation.

Emission of N₂O has increased by 6.9 % from 1990 to 2020.

Industrial processes and product use

Emissions from industrial processes and product use (consumption of halocarbons and SF₆) other than fuel combustion amount to 2.4 % of the total emission in CO₂ equivalents excluding LULUCF in 2020. The main source is consumption of HFCs. Emission of F-gases has increased considerably since 1990.

Agriculture

The agricultural sector contributes with 1.5 % of the total GHG emissions excluding LULUCF in 2020, 44.6 % of the total CH₄ emission and 22.8 % of the total N₂O emission. The total emission from this sector has decreased by 6.6 % from 1990 to 2020. This decrease is due to a fall in the number of reindeer from 6,000 heads in 1990 to 3,000 heads in 2020 and a fall in the number of sheep from 19,929 in 1990 to 18,105 in 2020. The use of inorganic fertilisers has overall increased since 1990. CH₄ emission has decreased by 17.8 % from 1990 to 2020, primarily due to the fall in the number of livestock; sheep and reindeer. In the same period N₂O emission has increased by 43.9 % due to a significant increase in the use of fertilizers.

LULUCF

Emission from the LULUCF sector amounts to just 0.2 % of total emission in 2020. Forests are assumed to be a source for the period 1990-2016. Since 2017 the Greenlandic forests have turned into a small net sink due to a reported slightly higher average height in two forests. In 2020 the net forest sink was 11.3 kt CO₂ equivalent. The emission from cropland is estimated to zero in 1990 (as there were no cropland in Greenland at the time) and a net source in 2020 of 48.1 tonnes CO₂ equivalent. The emission from grassland has been estimated to 210 tonnes CO₂ in 1990 increasing to 1,302 tonnes CO₂ equivalent in 2020.

Waste

The waste sector contributes with 2.8 % of the total greenhouse gas emissions in 2020, 46.3 % of the total CH₄ emission and 53.6 % of the total N₂O emission. Total emission from this sector has decreased by 9.8 % from 1990 to 2020. This decrease is caused by a drop in the CH₄ emission from incineration and open burning by 27.7 %, a decrease in the N₂O emission from incineration and open burning by 22.6 % and a decrease in N₂O emission from waste water handling by 26.6 %.

Total GHG emission from waste incineration without energy recovery has decreased by 9.8 % from 1990 to 2019 due to an increasing amount of waste incineration with energy recovery and a continuous decrease in waste water from industrial fishing plants in 2020. Emission from incinerated waste used for heat production is included in the 1A1 IPCC category Energy Industries.

16.2.4 Description and interpretation of emission trends for indirect greenhouse gases and SO₂

NO_x

The largest sources to emission of NO_x are AFF (Agriculture, Forestry and Fisheries) followed by Transport and combustion in Energy Industries (public power and district heating plants). The AFF-sector is the most contributing sector to the emission of NO_x. In 2020, 58.5 % of the Greenlandic emission of NO_x came from AFF-related activities. The emission of NO_x from AFF varies from year to year. The emissions from transport obtain 24.9 % of total emissions in 2020.

From 1990 to 2020, emission of NO_x from AFF has increased by 43.2 %, while emissions from transport have increased by 6.2 %. In the same period, total emission of NO_x has increased by 11.3 %.

The emissions from energy industries obtain 6.5 % of total emission in 2020. The emission from energy industries have decreased by 45.6 % from 1990 to 2020. The decrease is due to a continuous substitution from fossil fuels to hydro power.

Emission of NO_x from waste handling obtains 1.0 % of total emission in 2020, see Figure 16.2.10.

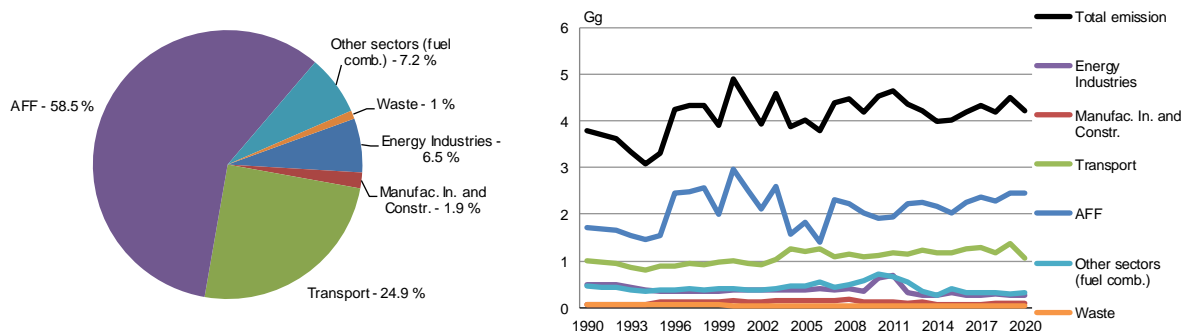

Figure 16.2.10 NO_x emissions. Distribution according to the main sectors (2020) and time series (1990-2020).

CO

Mobile sources like transport and AFF (agriculture, forestry and fisheries) contribute significantly to the total emission of this pollutant. However, In 2020 Transport is the largest contributor to the total CO emission, see Figure 16.2.11.

Total CO emission has increased by 44.0 % from 1990 to 2020, largely due to increasing emissions from road transportation and civil aviation. Emissions from energy industries have been cut by 46.9 % since 1990, while emissions from transport have increased by 122.4 % since 1990.

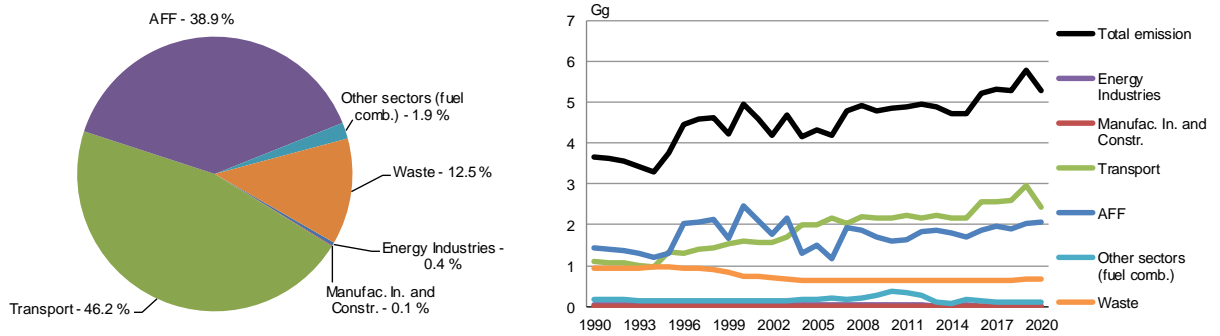

Figure 16.2.11 CO emissions. Distribution according to the main sectors (2020), and time series (1990-2020).

NMVOG

The emissions of NMVOG originate from many different sources and can be divided into two main groups: incomplete combustion and evaporation. Road vehicles and other mobile sources such as national navigation vessels fishing vessels and off-road machinery are the main sources of NMVOG emissions from incomplete combustion processes. Road transportation and fishing vessels are the main contributors to this pollutant. Road transportation is included under transportation, which obtain 44.2 % of total NMVOG emission in 2020. Fishing vessels are included under AFF (agriculture, forestry and fisheries), which obtain 37.9 % of total NMVOG emission in 2020, see Figure 16.2.12.

The evaporative emissions mainly originate from the use of solvents and the extraction, handling and storage of oil. Emissions from solvent and other product use are included under Industrial Processes and Product Use. The emission from this sector has increased by 27.7 % from 1990 to 2020.

Total anthropogenic emission of NMVOG has increased by 52.9 % from 1990 to 2020, largely due to the increase in road transportation and AFF activities.

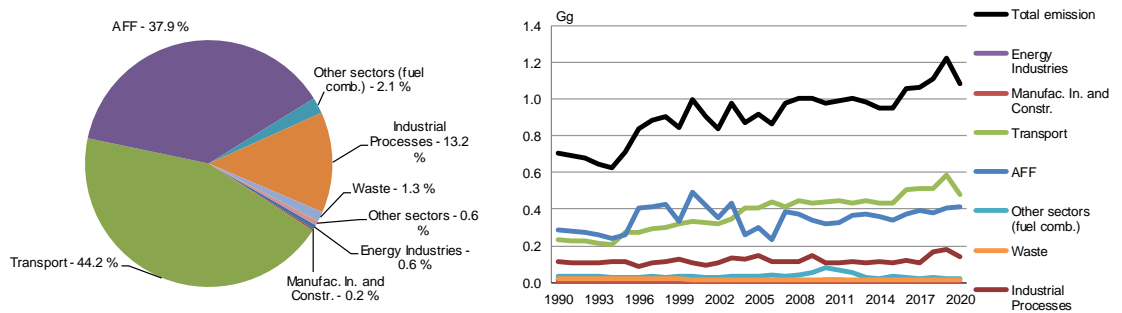

Figure 16.2.12 NMVOG emissions. Distribution according to the main sectors (2020), and time series (1990-2020).

SO₂

The main part of the SO₂ emission originates from the combustion of fossil fuels mainly gasoil in public power and district heating plants. From 1990 to 2020, total emission of SO₂ decreased by 7.0 %.

Emissions from AFF (Agriculture, Forestry and Fisheries) obtain 33.6 % of total SO₂ emission in 2020 followed by Energy Industries obtaining 20.0 %. Emissions from other industrial combustion plants, non-industrial combustion plants and mobile sources are likewise important. Transportation contributed with 10.3 % of total SO₂ emission in 2020.

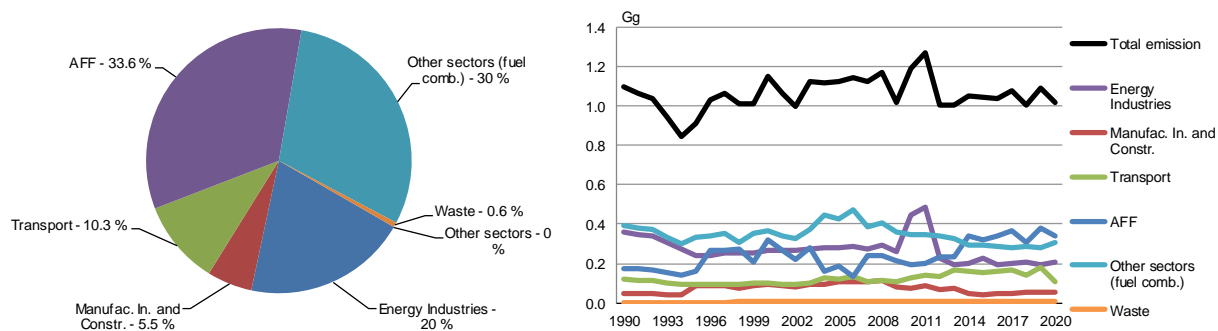

Figure 16.2.13 SO₂ emissions. Distribution according to the main sectors (2020), and time series (1990-2020).

16.3 Energy (CRF sector 1)

16.3.1 Overview of sector

The emission of greenhouse gases from energy activities includes CO₂, CH₄ and N₂O emission from fuel combustion. In 2010 fugitive emission of CO₂, CH₄ and N₂O occurred for the first time due to the initiation of well drilling and testing for oil and gas. However, since it has been impossible to obtain any information on the amount of oil and gas picked up during drillings in 2010 and 2011, fugitive emissions has been labelled with the notation key NA.

Emissions from the energy sector are reported in CRF Tables 1.A(a), 1.A(b), 1.A(c), 1.A(d) and 1.B. Furthermore, the emission of non-methane volatile organic compounds (NMVOC), NO_x, CO and SO₂ from fuel combustion is given in CRF Table 1.

Summary tables for the energy sector are shown in Table 16.3.1.

Table 16.3.1 Emission of CO₂ from the Energy Sector.

Greenhouse gas source and sink categories	1990	1991	1992	1993	1994	1995	1996	1997	1998	1999	2000
	Gg										
1. Energy	621.6	606.8	592.7	542.8	492.7	531.1	593.6	614.2	593.0	590.7	664.0
A. Fuel Combustion (Sectoral Approach)	621.6	606.8	592.7	542.8	492.7	531.1	593.6	614.2	593.0	590.7	664.0
1. Energy Industries	182.2	177.0	172.8	156.4	139.9	120.8	121.6	128.6	126.5	128.7	132.1
2. Manufacturing Industries and Construction	26.5	25.7	25.1	22.6	20.2	43.8	44.5	46.2	40.0	45.8	48.1
3. Transport	96.1	95.6	93.6	87.2	80.8	88.8	92.7	96.7	101.2	104.5	105.9
4. Other Sectors	308.7	300.6	293.5	269.5	245.5	271.1	328.1	336.2	318.7	305.1	371.2
5. Other	8.2	8.0	7.8	7.0	6.3	6.6	6.6	6.6	6.6	6.6	6.6
B. Fugitive Emissions from Fuels	NO	NO	NO	NO	NO	NO	NO	NO	NO	NO	NO
C. CO ₂ Transport and Storage	NO	NO	NO	NO	NO	NO	NO	NO	NO	NO	NO
<i>continued</i>	2001	2002	2003	2004	2005	2006	2007	2008	2009	2010	2011
1. Energy	614.5	576.2	646.2	636.4	640.5	658.8	649.7	674.3	589.4	675.4	722.0
A. Fuel Combustion (Sectoral Approach)	614.5	576.2	646.2	636.4	640.5	658.8	649.7	674.3	589.4	675.4	722.0
1. Energy Industries	133.2	133.9	134.5	138.5	137.1	142.4	135.1	144.0	126.0	226.5	251.8
2. Manufacturing Industries and Construction	45.7	43.2	49.8	50.7	55.1	55.7	57.4	59.4	43.2	38.7	47.3
3. Transport	96.1	92.4	101.4	113.6	111.9	121.2	110.4	117.1	105.9	108.5	115.5
4. Other Sectors	332.9	300.1	354.0	326.2	329.1	330.0	339.1	343.9	298.3	277.4	286.0
5. Other	6.6	6.6	6.6	7.5	7.3	9.7	7.7	10.0	16.0	24.4	21.3
B. Fugitive Emissions from Fuels	NO	NO	NO	NO	NO	NO	NO	NO	NO	NO	NO
C. CO ₂ Transport and Storage	NO	NO	NO	NO	NO	NO	NO	NO	NO	NO	NO
<i>continued</i>	2012	2013	2014	2015	2016	2017	2018	2019	2020		
1. Energy	575.6	558.9	518.4	521.5	522.5	539.7	540.3	551.0	532.9		
A. Fuel Combustion (Sectoral Approach)	575.6	558.9	518.4	521.5	522.5	539.7	540.3	551.0	532.9		
1. Energy Industries	111.2	95.5	96.9	111.2	92.2	95.3	99.2	92.4	98.1		
2. Manufacturing Industries and Construction	36.5	39.3	25.2	23.4	26.5	26.0	30.3	29.1	29.3		
3. Transport	110.7	110.1	104.7	104.1	111.8	118.6	112.7	126.7	91.9		
4. Other Sectors	301.4	309.0	289.1	273.0	286.1	295.1	293.0	298.5	309.4		
5. Other	15.6	4.9	2.4	9.7	6.0	4.7	5.1	4.3	4.1		
B. Fugitive Emissions from Fuels	NO	NO	NO	NO	NO	NO	NO	NO	NO		
C. CO ₂ Transport and Storage	NO	NO	NO	NO	NO	NO	NO	NO	NO		

Table 16.3.2 Emission of CH₄ from the Energy Sector.

Greenhouse gas source and sink categories	1990	1991	1992	1993	1994	1995	1996	1997	1998	1999	2000
	Gg										
1. Energy	0.05	0.05	0.05	0.04	0.04	0.04	0.05	0.05	0.05	0.05	0.06
A. Fuel Combustion (Sectoral Approach)	0.05	0.05	0.05	0.04	0.04	0.04	0.05	0.05	0.05	0.05	0.06
1. Energy Industries	0.01	0.01	0.01	0.01	0.01	0.01	0.01	0.01	0.01	0.01	0.01
2. Manufacturing Industries and Construction	0.00	0.00	0.00	0.00	0.00	0.00	0.00	0.00	0.00	0.00	0.00
3. Transport	0.00	0.00	0.00	0.00	0.00	0.01	0.00	0.01	0.01	0.01	0.01
4. Other Sectors	0.04	0.03	0.03	0.03	0.03	0.03	0.03	0.04	0.03	0.03	0.04
5. Other	0.00	0.00	0.00	0.00	0.00	0.00	0.00	0.00	0.00	0.00	0.00
B. Fugitive Emissions from Fuels	NO	NO	NO	NO	NO	NO	NO	NO	NO	NO	NO
<i>Continued</i>	2001	2002	2003	2004	2005	2006	2007	2008	2009	2010	2011
1. Energy	0.05	0.05	0.06	0.06	0.06	0.06	0.06	0.06	0.05	0.06	0.06
A. Fuel Combustion (Sectoral Approach)	0.05	0.05	0.06	0.06	0.06	0.06	0.06	0.06	0.05	0.06	0.06
1. Energy Industries	0.01	0.01	0.01	0.01	0.01	0.01	0.01	0.01	0.01	0.01	0.02
2. Manufacturing Industries and Construction	0.00	0.00	0.00	0.00	0.00	0.00	0.00	0.00	0.00	0.00	0.00
3. Transport	0.01	0.01	0.01	0.01	0.01	0.01	0.01	0.01	0.01	0.01	0.01
4. Other Sectors	0.04	0.03	0.04	0.04	0.04	0.04	0.04	0.04	0.03	0.03	0.03
5. Other	0.00	0.00	0.00	0.00	0.00	0.00	0.00	0.00	0.00	0.00	0.00
B. Fugitive Emissions from Fuels	NO	NO	NO	NO	NO	NO	NO	NO	NO	NA	NA
<i>Continued</i>	2012	2013	2014	2015	2016	2017	2018	2019	2020		
1. Energy	0.05	0.05	0.05	0.05	0.05	0.05	0.05	0.05	0.05		
A. Fuel Combustion (Sectoral Approach)	0.05	0.05	0.05	0.05	0.05	0.05	0.05	0.05	0.05		
1. Energy Industries	0.01	0.01	0.01	0.01	0.01	0.01	0.01	0.01	0.01		
2. Manufacturing Industries and Construction	0.00	0.00	0.00	0.00	0.00	0.00	0.00	0.00	0.00		
3. Transport	0.01	0.01	0.01	0.01	0.01	0.01	0.01	0.01	0.01		
4. Other Sectors	0.03	0.03	0.03	0.03	0.03	0.03	0.03	0.03	0.03		
5. Other	0.00	0.00	0.00	0.00	0.00	0.00	0.00	0.00	0.00		
B. Fugitive Emissions from Fuels	NO	NO	NO	NO	NO	NO	NO	NO	NO		

Table 16.3.3 Emission of N₂O from the Energy Sector.

Greenhouse gas source and sink categories	1990	1991	1992	1993	1994	1995	1996	1997	1998	1999	2000
	Gg										
1. Energy	0.01	0.01	0.01	0.01	0.01	0.01	0.01	0.01	0.01	0.01	0.01
A. Fuel Combustion (Sectoral Approach)	0.01	0.01	0.01	0.01	0.01	0.01	0.01	0.01	0.01	0.01	0.01
1. Energy Industries	0.00	0.00	0.00	0.00	0.00	0.00	0.00	0.00	0.00	0.00	0.00
2. Manufacturing Industries and Construction	0.00	0.00	0.00	0.00	0.00	0.00	0.00	0.00	0.00	0.00	0.00
3. Transport	0.00	0.00	0.00	0.00	0.00	0.00	0.00	0.00	0.00	0.00	0.00
4. Other Sectors	0.00	0.00	0.00	0.00	0.00	0.00	0.00	0.00	0.00	0.00	0.00
5. Other	0.00	0.00	0.00	0.00	0.00	0.00	0.00	0.00	0.00	0.00	0.00
B. Fugitive Emissions from Fuels	NO	NO	NO	NO	NO	NO	NO	NO	NO	NO	NO
<i>continued</i>	2001	2002	2003	2004	2005	2006	2007	2008	2009	2010	2011
1. Energy	0.01	0.01	0.01	0.01	0.01	0.01	0.01	0.01	0.01	0.01	0.01
A. Fuel Combustion (Sectoral Approach)	0.01	0.01	0.01	0.01	0.01	0.01	0.01	0.01	0.01	0.01	0.01
1. Energy Industries	0.00	0.00	0.00	0.00	0.00	0.00	0.00	0.00	0.00	0.00	0.00
2. Manufacturing Industries and Construction	0.00	0.00	0.00	0.00	0.00	0.00	0.00	0.00	0.00	0.00	0.00
3. Transport	0.00	0.00	0.00	0.00	0.00	0.00	0.00	0.00	0.00	0.00	0.00
4. Other Sectors	0.00	0.00	0.00	0.00	0.00	0.00	0.00	0.00	0.00	0.00	0.00
5. Other	0.00	0.00	0.00	0.00	0.00	0.00	0.00	0.00	0.00	0.00	0.00
B. Fugitive Emissions from Fuels	NO	NO	NO	NO	NO	NO	NO	NO	NO	NA	NA
<i>continued</i>	2012	2013	2014	2015	2016	2017	2018	2019	2020		
1. Energy	0.01	0.01	0.01	0.01	0.01	0.01	0.01	0.01	0.01		
A. Fuel Combustion (Sectoral Approach)	0.01	0.01	0.01	0.01	0.01	0.01	0.01	0.01	0.01		
1. Energy Industries	0.00	0.00	0.00	0.00	0.00	0.00	0.00	0.00	0.00		
2. Manufacturing Industries and Construction	0.00	0.00	0.00	0.00	0.00	0.00	0.00	0.00	0.00		
3. Transport	0.00	0.00	0.00	0.00	0.00	0.00	0.00	0.00	0.00		
4. Other Sectors	0.00	0.00	0.00	0.00	0.00	0.00	0.00	0.00	0.00		
5. Other	0.00	0.00	0.00	0.00	0.00	0.00	0.00	0.00	0.00		
B. Fugitive Emissions from Fuels	NA	NA	NO	NO	NO	NO	NO	NO	NO		

16.3.2 Source category description

In this section emission source categories, fuel consumption data and emission data are presented.

Activity data on fuel consumption is based on the same methodology that Statistics Greenland has used to the annual statistics on energy previously published by Statistics Greenland and information on waste incineration with energy recovery. The annual statistics on energy is divided into sectors according to the Greenlandic Business Register (GB2018). The register comprises 745 business categories. The official statistics on energy is published by aggregation into 34 categories.

In the Greenlandic emission data, all activity rates and emissions are based on the official statistics on energy. However, in order to fit the new CRF format fuel consumption from the official statistics on energy is further aggregated into 19 sectors.

Fuel combustion

In 2020, total fuel combustion was 7,426 TJ of which 7,211 TJ was liquid fossil fuels.

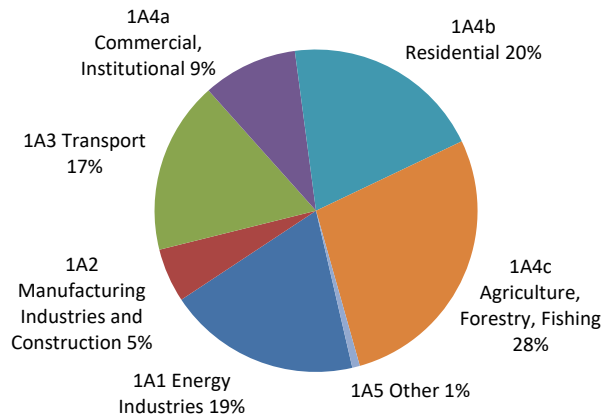

Figure 16.3.1 Fuel combustion rates, fossil fuels 2020 (Statistics Greenland).

In Greenland gasoil, kerosene and gasoline are used in fuel combustion. Fueloil has been imported from 2010 to 2019, and is combusted in ships. Gasoil and kerosene are the most utilised fuels. Gasoil is used in power plants to produce electricity and heat, as well as in district heating, private households, industries and for transportation. In 2010 and 2011 the combustion of gasoil increased significantly due to oil explorations. Due to a standstill in oil explorations total fuel combustion dropped again in 2012.

Kerosene is primarily used in aviation as jetfuel, but also for heating in minor settlements.

Activity data on the consumption of Liquid Petrol Gas (LPG) exists for the full period 1990-2020. However, consumption of LPG amount to less than 1 % of total fuel combustion, see Figure 16.3.2.

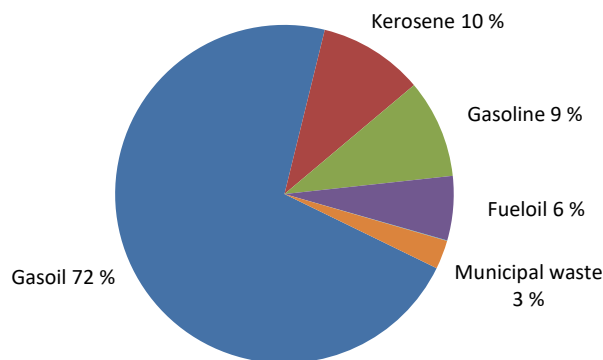
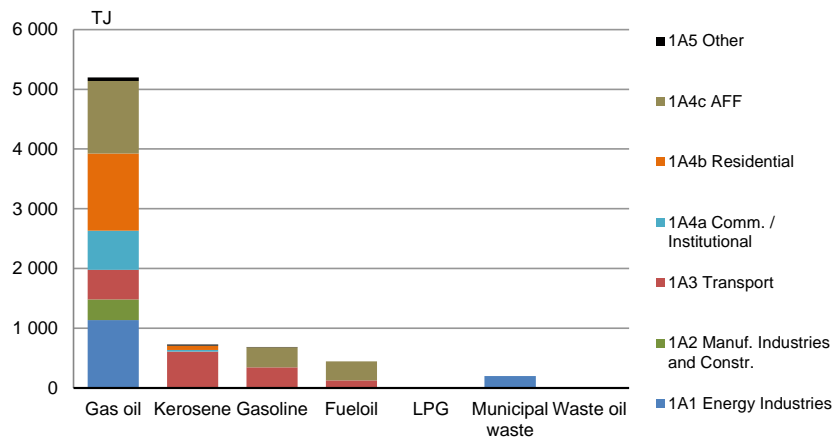

Figure 16.3.2 Fuel combustion, 2020 (Statistics Greenland).

Time series on fuel consumption are presented in Figure 16.3.3. Total fuel consumption has decreased by 13.4 % from 1990 to 2020. This overall decrease in fuel consumption is caused by a drop in the consumption of liquid fossil by 15.4 %. Consumption of renewable waste-energy has increased continuously with a total increase of 375.8 % from 1990 to 2020. The dropping fuel consumption in 2011-2014 was caused by an overall recession in the Greenlandic economy and the continuous substitution of liquid fuel with electricity from hydro power in the energy sector. In 2020, fuel consumptions decreased by 3.1 %.

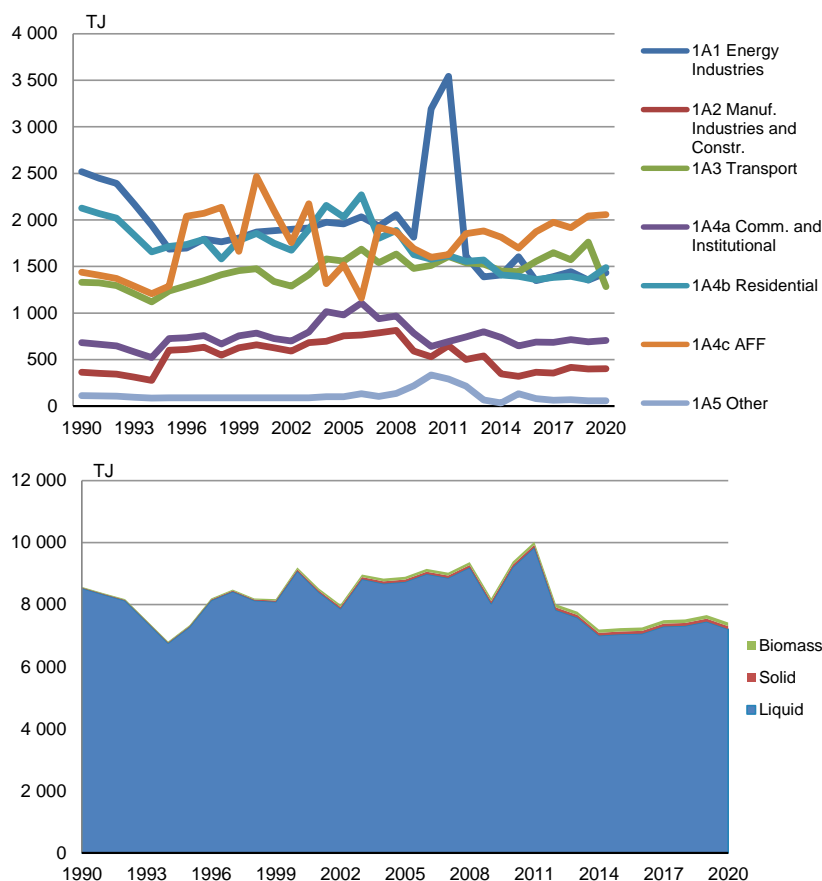

Figure 16.3.3 Fuel consumption time series 1990-2020 (Statistics Greenland).

Fuel consumption is dominated by liquid fuels e.g. gasoil, kerosene and gasoline. In 2020 total fuel consumption consists of 97.1 % liquid fuels, 1.6 % biomass and 1.3 % solid fuels.

In 2020, Energy Industries accounted for 19.3 % of total fuel consumption. From 1990 to 1995, fuel consumption in Energy Industries decreased significantly due to the introduction of the first hydro power plant in 1993, and the introduction of burning waste to produce heat for district heating networks in 1989. Dependence on gasoil decreased immediately. Nevertheless, from 1995 onwards consumption of gasoil once again increased due to the general economic development. In 2009, hydro power productions increased further when a fourth plant was opened. Together with a relatively warm 2009 winter fuel consumption in Energy Industries decreased additionally. In 2010 and 2011 fuel consumption increased significantly due to oil explorations along the westcoast of Greenland. In 2012-2014, fuel consumption decreased once again due to a standstill in the oil exploration, the opening of the fifth hydro power plant and a general recession in the Greenlandic economy. This all changed in 2015 when the economy improved, which in combination with a

very cold winter caused fuel consumptions in Energy Industries to increase as well. In 2016, fuel consumption was reduced in Energy Industries due to a warm winter.

In 2017 the fuel consumption increased in Energy Industries due to the combination of a colder winter, and a relative low waterlevel in the reservoir supplying the hydropower plant in Sisimiut. In 2019 the fuel consumption decreased in Energy Industries due to the combination of a warmer winter and an improvement in the waterlevel in the Sisimiut reservoir. In 2019 fuel consumption primarily increased due to an increase in the fuel consumption in the transport sector. In 2020 fuel consumption decreased due to COVID19 that primarily lowered the activity within the transport sector.

Fuel consumption regarding Agriculture, Forestry and Fisheries (AFF) accounted for 27.7 % of total fuel consumption in 2020 making AFF the largest energy consuming sector. Before 2004, time series on fuel combustion in this sector varied a great deal due to fluctuations in fishing activities from year to year. However, some uncertainty is expected in the 1990-2003 time series on fuel consumption in Agriculture, Forestry and Fisheries.

Fuel consumption in Residential accounted for 20.0 % of total fuel consumption in 2019 making Residential the second largest energy consuming sector.

Fuel consumption in Energy Industries accounted for 19.3 % of total fuel consumption in 2020 making Energy Industries the third largest energy consuming sector. Fluctuations in fuel consumption are largely a result of variation in outdoor temperatures from year to year, which also causes fluctuations in fuel consumption in Energy Industries.

Fuel consumption used for transport accounted for 17.3 % of total fuel consumption in 2020.

For 2004-2020 Statistics Greenland has conducted statistics on energy including detailed information on fuel consumption in businesses and private households; see Section 16.3.3. Compared to the new statistics on energy the historic construction of time series on fuel consumption in 1990-2003 was based on a much simpler method. Some uncertainty is therefore to be expected in the 1990-2003 time series on sector-divided fuel consumption.

Fugitive Emissions from Fuels

Greenland has no coal mines, no off-shore activities, no oil refineries, no natural gas transmission or distribution. For that reason there have been no fugitive emissions from such activities in 1990-2009. However in 2010 a Scottish company initiated a search for oil along the westcoast of Greenland. Three wells were drilled and tested in 2010. Five wells in 2011. There has been no drilling activity since 2011.

In the 2014 National Inventory Report calculation of fugitive emission was based on the annual number of drilled and tested wells and IPCC Guideline emission factors. As from the 2015 National Inventory report fugitive emission is to be based on the amount of drilled oil and gas and IPCC Guideline emission factors.

However, the Scottish company has not been able to provide the Greenland Government with any information on the amount of oil and gas picked up during drillings in 2010 and 2011. To our knowledge the Scottish company on-

ly discovered a few minor kicks with some minor inflow of water or gas during drillings.

With no data available, activity data in 2010 and 2011 has been marked with the notation key Not Applicable (NA). Since no amounts could be estimated, all fugitive emissions are assumed to be zero, and also marked with the notation key Not Applicable (NA). This decision has been made in agreement with the DCE.

Besides energy production some fugitive emission occurs in the distribution of fuel e.g. when refuelling from ships to on-shore tanks, onshore loading of fuel to ships and offshore loading of ships. The emission would only be in the form of NMVOC. The fugitive emission from loading/unloading of ships is currently not estimated.

International bunker fuels

International Aviation Bunkers

Emissions from international aviation bunkers are considered to be of negligible importance. The Greenland Airport Authority has reported the annual amount of jet fuel loaded into foreign aircrafts including Danish aircrafts. However, it is still not possible to distinguish between Danish aircrafts and other aircrafts. Since most foreign aircrafts by far are Danish the annual amount of jet fuel loaded into foreign aircrafts are therefore included as part of the IPCC category 1A3a Domestic aviation.

International Navigation Bunkers

Emission from international marine bunkers is included from 2004 and onwards. Before 2004 international marine bunkers are considered to be of negligible importance.

Feedstocks, reductants and other non-energy use of fuels

At the moment Greenland has no production or use of feedstocks. Emissions from non-energy use of fuels (e.g. bitumen and solvents) are included in the sector Industrial Processes and Product Use (CRF sector 2).

16.3.3 Methodological issues

Activity data

The Greenlandic emission inventory for fuel combustion has been performed according to the IPCC tier 1 methodology. The inventory is based on activity data from the Greenlandic energy statistics and on emission factors for different fuels, plants and sectors.

Total fuel combustion is based on data from Polaroil, Air BP (earlier Statoil) and Malik Supply A/S. Polaroil imports and distributes fuel in all parts of Greenland. Air BP imports and distributes fuel in Kangerlussuaq. Malik Supply A/S, a Danish company, re-distributes fuel bought from Polaroil to Greenlandic trawlers, ships etc. By using detailed data from Polaroil, Air Bp and Malik Supply A/S it is possible to determine total import, total export, total international bunkers and total domestic fuel combustion.

Next, total domestic fuel combustion is divided into business sectors and private households by using data from a survey on energy consumption, company specific sales data from Polaroil and local fuel distributors, relevant tax accountings, and by estimation.

Since 2008 Statistics Greenland has conducted an annual survey among larger companies. By completing a questionnaire each company returns detailed information on annual consumption of specific types of fuel. The survey covered 48.7 % of total GHG emission from energy combustion in 2020, see Table 16.3.4.

By using detailed information on sales from Polaroil and local fuel distributors it is possible to determine fuel combustion in private businesses and public offices with an automatic deal on supply. Sales data covered 15.5 % of total GHG emission from energy combustion in 2020, see Table 16.3.4.

Tax accountings in DKK are used to determine annual consumption of fuel in private businesses, in municipalities, and within the Greenland Government. At the moment tax accountings are primarily used for determining fuel combustion in municipalities and public offices in settlements. Accountings cover 7.0 % of total GHG emission from energy combustion in 2020, see Table 16.3.4.

The remaining amount of total inland fuel combustion 28.9 % - is divided into sectors and private households by estimation. This work is carried out by involving statistical material on population, housing, and fisheries and hunting. Danish Business Register (CVR) is used to divide remaining companies into sectors. Information on employees, operating units, vehicles etc. is used to determine the activity in each company.

Fuel combustion in private households is estimated using detailed information from a number of local fuel distributors. Fuel deliveries are registered by buildings. In Greenland each building has a unique number registered in the Greenlandic Area Register (NIN). By combining the NIN-register and the CVR-register (see above) with statistics on housing and population each building is labelled *private household* or located to a sector describing the main activity in the building. This new building-sector register, completed annually, is used extensively to determine the buyer of fuel delivered by Polaroil or local fuel distributors.

Fuel combustion in road traffic is based on a model designed by Statistics Greenland. The model contains data on the vehicle stock obtained from the Greenland Police Department's register on engine data. The vehicles are divided into broad categories of type i.e. personal car, lorry, taxi, truck, ambulance, motorbike etc. Each category is assigned with ratios on fuel type and mileage. Input data on mileage is derived from an annual survey among businesses and private road traffic in 2008-2020. Each vehicle is divided in business categories or labelled *private vehicle* according to the owner. For each group the emissions are estimated by combining vehicle and annual mileage numbers with standard emission factors according to the type of fuel. The model does not take cold start or hot engines into account.

For air traffic annual emissions are based on activity data from Air Greenland A/S and sales data from the Greenland Airport Authority. For navigation, ferries and freight, annual emissions are based on activity data from Royal Arctic Line A/S (freight), Royal Arctic Tankers A/S (freight) and Arctic Umiaq Line A/S (passengers).

Table 16.3.4 shows the part of total CO₂ emission divided into sources - survey, specific sales data, tax accountings, and estimation.

Table 16.3.4 Allocation of CO₂ emission from fuel combustion into sources to sectoral division (2007-2020).

	2007	2008	2009	2010	2011	2012	2013
	Pct.						
Total	100.0	100.0	100.0	100.0	100.0	100.0	100.0
Survey	49.6	50.3	52.8	63.0	61.3	53.2	52.2
Sales data from Polaroil	3.6	3.4	3.0	4.2	5.0	5.7	6.3
Sales data from local fuel distributors	5.1	6.6	6.5	5.0	5.6	6.1	5.2
Accountings	12.8	12.2	12.7	10.8	11.0	13.1	15.4
Estimation	29.0	27.5	25.0	17.0	17.0	21.8	21.0
<i>Continued</i>	2014	2015	2016	2017	2018	2019	2020
Total	100.0	100.0	100.0	100.0	100.0	100.0	100.0
Survey	44.8	47.5	41.4	44.0	46.3	42.2	48.7
Sales data from Polaroil	6.8	7.0	6.9	6.4	6.8	5.9	15.5
Sales data from local fuel distributors	4.6	4.2	5.0	5.8	5.6	6.0	0.0
Accountings	15.6	16.9	20.5	13.9	14.6	14.6	7.0
Estimation	28.3	24.4	26.2	30.0	26.7	31.4	28.9

The procedure described above is used to determine fuel combustion in sectors and private households during the period 2004-2020. Formerly, the period 1990-2003, activity data on sectors and private households were estimated using aggregated statistics on population, housing, companies, data on sales from Polaroil, and data on energy consumption in larger companies.

An increasing part of municipal waste incineration is utilised for heat and power production. Thus, incineration with energy-recovery is included in the Energy sector. Table 16.3.5 shows the activity data on fuel combustion for the period 1990-2020.

Table 16.3.5 Activity data on fuel combustion (SINK categories).

	1990	1991	1992	1993	1994	1995	1996	1997	1998	1999
	TJ									
Total	8 572	8 370	8 179	7 496	6 812	7 342	8 201	8 486	8 201	8 178
Energy industries	2 519	2 447	2 393	2 169	1 944	1 685	1 698	1 794	1 766	1 805
Manufacturing industries and construction	363	353	344	311	278	601	610	633	549	628
Domestic aviation	541	556	547	524	500	581	636	660	775	748
Road transport	501	488	476	437	397	370	369	387	361	401
Domestic navigation	288	280	273	248	224	285	285	299	275	308
Commercial/Institutional	683	663	647	584	521	726	734	759	669	754
Residential	2 127	2 068	2 020	1 838	1 657	1 716	1 737	1 792	1 581	1 780
AFF	1 437	1 406	1 372	1 289	1 206	1 288	2 040	2 071	2 134	1 664
Other	113	110	107	97	86	91	91	91	91	91
<i>continued</i>	2000	2001	2002	2003	2004	2005	2006	2007	2008	2009
Total	9 199	8 521	8 002	8 970	8 840	8 898	9 153	9 031	9 371	8 207
Energy industries	1 868	1 885	1 900	1 915	1 976	1 959	2 032	1 934	2 057	1 813
Manufacturing industries and construction	660	626	592	682	696	755	763	787	814	592
Domestic aviation	738	632	603	646	608	633	691	701	753	635
Road transport	417	399	388	433	508	504	575	504	535	493
Domestic navigation	321	308	297	334	464	420	421	334	347	350
Commercial/Institutional	784	726	700	797	1 014	979	1 107	939	969	784
Residential	1 854	1 751	1 674	1 899	2 155	2 032	2 271	1 804	1 888	1 628
AFF	2 466	2 101	1 756	2 174	1 317	1 516	1 161	1 921	1 871	1 691
Other	91	91	91	91	103	100	132	105	138	219
<i>continued</i>	2010	2011	2012	2013	2014	2015	2016	2017	2018	2019
Total	9 387	10 026	8 014	7 773	7 199	7 244	7 266	7 501	7 524	7 665
Energy industries	3 193	3 542	1 609	1 388	1 408	1 606	1 346	1 390	1 445	1 353
Manufacturing and construction	531	649	501	539	346	322	363	356	415	400
Domestic aviation	654	723	660	593	555	560	593	673	665	696
Road transport	478	479	469	462	434	427	470	460	481	542
National navigation	378	405	413	471	463	457	491	514	425	523
Commercial/Institutional	641	694	742	800	737	647	689	685	713	692
Residential	1 577	1 615	1 554	1 570	1 408	1 394	1 358	1 382	1 394	1 355
AFF	1 600	1 628	1 851	1 883	1 814	1 698	1 873	1 974	1 916	2 043
Other	335	292	215	67	33	134	82	65	70	59
<i>continued</i>	2020									
Total	7 426									
Energy industries	1 434									
Manufacturing and construction	402									
Domestic aviation	378									
Road transport	545									
National navigation	361									
Commercial/Institutional	705									
Residential	1 486									
AFF	2 058									
Other	57									

Emission factors

The CO₂ emission factors applied are presented in Table 16.3.6. For liquid fossil fuels and the biomass part of municipal waste the same emission factor is applied for 1990-2020. Default emission factors are used for all liquid fossil fuels except for gasoil.

In 2013, a technical analysis was conducted on the arctic gasoil that is by far the most dominant type of fuel in Greenland. The analysis was conducted by

the Danish Technological Institute in order to gain a country specific emission factor on the Greenlandic gasoil, see Table 16.3.6 and Section 16.3.7 for further details.

In reporting to the Climate Convention, the CO₂ emission is aggregated to three fuel types: Liquid fuel, Biomass and Other fuel.

The CO₂ emission from incineration of municipal waste with energy-recovery is divided into two parts: The emission from combustion of the fossil content of waste, which is included in the Greenlandic total, and the emission from combustion of the rest of the waste – the biomass part, which is reported as a memo item.

In the IPCC reporting, the fossil part of the waste and the associated emissions from fuel combustion of the plastic content of the waste is reported in the fuel category, *Other fuels*. Greenland uses the Danish emission factors on municipal waste, which have been revised recently due to new information. The time series for the fossil CO₂ emission factor for municipal waste is shown in Table 16.3.6, see chapter 3 for description.

Table 16.3.6 CO₂ emission factors 1990-2020.

Fuel	Year	Emission factor	Unit	Reference type	IPCC fuel category
Gasoil	-	72.967	kg pr GJ	Country specific	Liquid
Kerosene	-	71.900	kg pr GJ	IPCC 2006	Liquid
Jet-Kerosene	-	71.500	kg pr GJ	IPCC 2006	Liquid
Gasoline	-	69.300	kg pr GJ	IPCC 2006	Liquid
Fueloil	-	77.400	kg pr GJ	IPCC 2006	Liquid
LPG	-	63.100	kg pr GJ	IPCC 2006	Liquid
Wasteoil	-	77.400	kg pr GJ	IPCC 2006	Liquid
Municipal waste – biomass	-	75.100	kg pr GJ	Country specific	Biomass
Municipal waste – fossil fuel	1990-2010	37.000	kg pr GJ	Country specific	Other fuels
Municipal waste – fossil fuel	2011	37.500	kg pr GJ	Country specific	Other fuels
Municipal waste – fossil fuel	2012	40.000	kg pr GJ	Country specific	Other fuels
Municipal waste – fossil fuel	2013-2020	42.500	kg pr GJ	Country specific	Other fuels

The CO₂ emission from gasoil has been calculated by using the same methodology as described in the IPCC Guidelines (IPCC, 2006). This methodology implies use of C content per fuel type (default) and fraction of carbon oxidised (default); see the equation below.

$$E_{CO_2} = \sum Act_a \times EF_{C,a} \times Ox \times 44 / 12$$

where:

Act_a = activity; consumption of fuel a

EF_{C,a} = C emission factor for fuel a

Ox = oxidation factor (by default equal to 1)

The emissions of CH₄, N₂O, NO_x, CO and NMVOC have been calculated at sector/fuel level by using IPCC default emission factors combined with measured/Danish EF waste incineration (with energy recovery), see Table 16.3.7 – Table 16.3.9 below.

The equation applied for each pollutant is:

$$E = \sum (EF_{ab} \times Act_{ab})$$

where:

EF = emission factor
 Act = activity; fuel input
 a = fuel type
 b = sector activity

CH₄

The CH₄ emission factors applied for 1990-2020 are presented in Table 16.3.7. Emission factors for municipal waste refer to emission measurements carried out in Danish plants (Nielsen et al., 2010). Other emission factors refer to the IPCC Guidelines (IPCC, 2006).

Table 16.3.7 CH₄ emission factors 1990-2020.

CRF sector	Liquid fuel						Bio- mass	Other fuel
	Gasoil	Kerosene	Gasoline	Fueloil	LPG	Wasteoil	Municipal waste	
g CH ₄ per GJ								
1A1 Energy Industries	3	3	3	3	1	3	30	30
1A2 Manufacturing Industries and Construction	2	2	2	2	5	-	-	-
1A3a Transport - Domestic aviation	0.5	0.5	0.5	0.5	-	-	-	-
1A3b Transport - Road transportation	3.9	20	25	5	50	-	-	-
1A3d Transport - Domestic navigation	5	5	5	5	-	-	-	-
1A4a Other sectors - Commercial, Institutional	10	10	10	10	5	-	-	-
1A4b Other sectors - Residential	10	10	10	10	5	-	-	-
1A4c Other sectors - AFF stationary	10	10	10	10	5	-	-	-
1A4c Other sectors - AFF mobile	5	5	5	5	5	-	-	-
1A5b Other - Military mobile	5	5	5	5	-	-	-	-

Source:

- IPCC Guidelines 2006: Gasoil, kerosene, gasoline, fueloil, LPG and waste oil.
 - Nielsen et al. (2010): Biomass and other fuel, both municipal waste.

N₂O

The N₂O emission factors applied for 1990-2020 are presented in Table 16.3.8. Emission factors for municipal waste refer to emission measurements carried out in Danish plants (Nielsen et al., 2010). Other emission factors refer to the IPCC Guidelines (IPCC, 2006).

Table 16.3.8 N₂O emission factors 1990-2020.

CRF sector	Liquid fuel						Bio- mass	Other fuel
	Gasoil	Kerosene	Gasoline	Fueloil	LPG	Wasteoil	Municipal waste	
g N ₂ O per GJ								
1A1 Energy Industries	0.6	0.6	0.6	0.6	0.1	0.6	4	4
1A2 Manufacturing Industries and Construction	0.6	0.6	0.6	0.6	0.1	-	-	-
1A3a Transport - Domestic aviation	2	2	2	2	-	-	-	-
1A3b Transport - Road transportation	3.9	0.6	8	0.6	0.1	-	-	-
1A3d Transport - Domestic navigation	0.6	0.6	0.6	0.6	-	-	-	-
1A4a Other sectors	0.6	0.6	0.6	0.6	0.1	-	-	-
1A5b Other - Military mobile	0.6	0.6	0.6	0.6	0.1	-	-	-

Source:

- IPCC Guidelines 2006: Gasoil, kerosene, gasoline, fueloil, LPG and waste oil.
 - Nielsen et al. (2010): Biomass and other fuel, both municipal waste.

SO₂, NO_x, NMVOC and CO

Emission factors for SO₂, NO_x, NMVOC and CO are listed in Table 16.3.9. The same emission factors have been applied in the period 1990-2020.

Table 16.3.9 SO₂, NO_x, NMVOC and CO emission factors 1990-2020 (g pr GJ).

Fuel group	Fuel	CRF sector	NO _x	CO	NMVOC	SO ₂	Ref	
Liquid	Gasoil	1A1 Energy Industries	200	15	5	141	1	
		1A2 Manufacturing Industries and Construction	200	10	5	141	1	
		1A3a Transport – Domestic aviation	300	100	50	141	1	
		1A3b Transport – Road transportation	800	1 000	200	141	1	
		1A3d Transport – Domestic navigation	1 500	1 000	200	141	1	
		1A4a,b Other sectors	100	20	5	141	1	
		1A4c Other sectors – AFF stationary	100	20	5	141	1	
		1A4c Other sectors – AFF mobile	1 200	1 000	200	141	1	
		1A5b Other – Military mobile	1 500	1 000	200	141	1	
Kerosene	Kerosene	1A1 Energy Industries	200	15	5	23	1	
		1A2 Manufacturing Industries and Construction	200	10	5	23	1	
		1A3a Transport – Domestic aviation	300	100	50	23	1	
		1A3b Transport – Road transportation	600	8 000	1 500	23	1	
		1A3d Transport – Domestic navigation	1 500	1 000	200	23	1	
		1A4a,b Other sectors	100	20	5	23	1	
		1A4c Other sectors – AFF stationary	100	20	5	23	1	
		1A4c Other sectors – AFF mobile	1 200	1 000	200	23	1	
		1A5b Other – Military mobile	1 500	1 000	200	23	1	
Gasoline	Gasoline	1A1 Energy Industries	200	15	5	46	1	
		1A2 Manufacturing Industries and Construction	200	10	5	46	1	
		1A3a Transport – Domestic aviation	300	100	50	46	1	
		1A3b Transport – Road transportation	600	8 000	1 500	46	1	
		1A3d Transport – Domestic navigation	1 500	1 000	200	46	1	
		1A4a,b Other sectors	100	20	5	46	1	
		1A4c Other sectors – AFF stationary	100	20	5	46	1	
		1A4c Other sectors – AFF mobile	1 200	1 000	200	46	1	
		1A5b Other – Military mobile	1 500	1 000	200	46	1	
Fueloil	Fueloil	1A1 Energy Industries	200	15	5	492	1	
		1A2 Manufacturing Industries and Construction	200	10	5	492	1	
		1A3a Transport – Domestic aviation	300	100	50	492	1	
		1A3b Transport – Road transportation	600	8 000	1 500	492	1	
		1A3d Transport – Domestic navigation	1 500	1 000	200	492	1	
		1A4a,b Other sectors	100	20	5	492	1	
		1A4c Other sectors – AFF stationary	100	20	5	492	1	
		1A4c Other sectors – AFF mobile	1 200	1 000	200	492	1	
		1A5b Other – Military mobile	1 500	1 000	200	492	1	
LPG	LPG	1A1 Energy Industries	150	20	5	0.13	1	
		1A2 Manufacturing Industries and Construction	150	30	5	0.13	1	
		1A3a Transport – Domestic aviation	-	-	-	-	1	
		1A3b Transport – Road transportation	600	400	5	0.13	1	
		1A3d Transport – Domestic navigation	-	-	-	-	1	
		1A4a,b Other sectors	50	50	5	0.13	1	
		1A4c Other sectors – AFF stationary	50	50	5	0.13	1	
		1A4c Other sectors – AFF mobile	1 000	400	5	0.13	1	
		1A5b Other – Military mobile	-	-	-	-	1	
Wasteoil	1A1	Energy Industries	200	15	5	477	1	
Municipal								
Biomass	waste	1A1	Energy Industries	134	7.4	0.98	138	2
Municipal								
Other fuel	waste	1A1	Energy Industries	134	7.4	0.98	138	2

Sources: 1) IPCC Guidelines 2006. 2) Nielsen et al., 2010.

16.3.4 Emissions

The greenhouse gas (GHG) emissions are listed in Table 16.3.10. The total emission of greenhouse gases from the energy sector accounts for 93.3 % of total Greenlandic GHG emission in 2020.

CO₂ emission from energy accounts for 99.2 % of the Greenlandic CO₂ emission (excluding net CO₂ emission from Land Use, Land Use Change and Forestry (LULUCF)). The CH₄ emission from fuel combustion (Sectoral Approach) accounts for 9.0 % of the Greenlandic emission and the N₂O emission from fuel combustion accounts for 23.1 % of the Greenlandic N₂O emission, see Table 16.3.10.

Table 16.3.10 Greenhouse gas emission 2020.

		CO ₂	CH ₄	N ₂ O
		Gg CO ₂ equivalent		
1A1	Fuel consumption, Energy Industries	98.1	0.3	0.5
1A2	Fuel consumption, Manufacturing Industries and Construction	29.3	0.0	0.1
1A3	Fuel consumption, Transport	91.9	0.2	1.2
1A4	Fuel consumption, Other sectors	313.6	0.8	0.8
1B	Fugitive emissions from fuel, Oil and natural gas	NO	NO	NO
Total emission from energy		532.9	1.3	2.5
Greenlandic emission (excluding net emission from LULUCF)		537.2	14.4	10.8
		%		
Emission share for energy		99.2	9.0	23.1

CO₂ is the most important GHG pollutant and accounts for 99.3 % of the GHG emission in CO₂ equivalents from energy in 2020, see Figure 16.3.4.

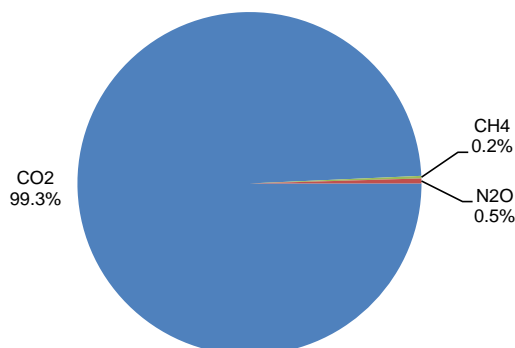

Figure 16.3.4 GHG emissions (CO₂ equivalent) from stationary combustion plants 2020.

Figure 16.3.5 depicts the time series of GHG emission in CO₂ equivalents from the energy sector. As shown by the blue curve the development in total GHG emission follows the CO₂ emission development very closely. Emission of CO₂ and total GHG emission are respectively 14.3 % and 14.2 % lower in 2020 compared to 1990.

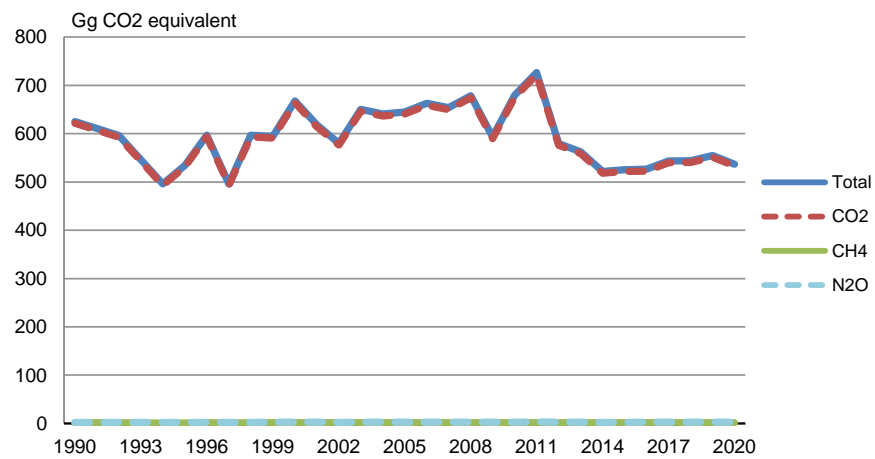

Figure 16.3.5 GHG emission time series for the Energy Sector.

From 1990 to 1994 total GHG emission was reduced by 21 %. This was primarily due to the introduction of the first hydropower plant in 1993 but also to the introduction of burning waste to produce heat for district heating network in 1989. Dependence on gasoil conversion decreased immediately. Nevertheless, from 1995 onwards consumption of gasoil once again increased due to the general economic development.

In 2001-2002 total GHG emission decreased due to a minor recession in the economy. However since 1994 GHG emissions have increased in general with some fluctuations from year to year. The fluctuations are largely a result of outdoor temperature variations from year to year i.e. in 2008 the winter was relatively colder than in 2007. As a result fuel consumption increased in 2008 increasing GHG emission from fuel combustion. In 2009 GHG emission decreased due to a significant substitution in Energy Industries from fuel consumption to hydro power production together with a relatively warmer winter. However, in 2010 and 2011 GHG emission increased by 14.5 % and 6.9 % due to the initiation of oil exploration.

In 2012-2014 GHG emission decreased by 20.3 %, 3.0 % and 7.3 % respectively due to the standstill in the oil exploration activities, a drop in fuel combustion in Energy Industries due to the opening of Greenland's fifth hydro power plant, and an overall recession in the Greenlandic economy.

Since 2014 emissions of GHG have more and less stayed level with only minor annual variations. In 2019 GHG emission increased due to higher activity in the transport sector. However, most recently in 2020 transport was affected a great deal due to COVID19. Combustion of fuel for transport dropped causing emission of GHG to drop as well.

CO₂

CO₂ emission from fuel combustion accounts for 99.2 % of the total Greenlandic CO₂ emission. Table 16.3.11 lists the CO₂ emission inventory for the energy sector in 2020 as well as the relative percentage for each category under the sectoral approach.

The table reveals that Agriculture, Forestry and Fisheries (AFF) accounts for 28.1 % of the CO₂ emission. Other large CO₂ emission sources are Residential with a share of 20.3 % and Energy Industries with 18.4 % as well as Transport with 17.3 %. These are sectors, which also account for a considerable share of fuel consumption.

Table 16.3.11 Emission of CO₂ from fuel combustion 2020.

	Gg	%
1A1 Energy Industries	98.1	18.4
1A2 Manufacturing Industries	29.3	5.5
1A3 Transport	91.9	17.3
1A4a Commercial / Institutional	51.4	9.7
1A4b Residential	108.4	20.3
1A4c Agriculture / Forestry / Fisheries	149.6	28.1
1A5 Other	4.1	0.8
1B Fugitive emissions from fuel	NO	NO
1C CO ₂ Transport and Storage	NO	NO
Total	532.9	100.0

CO₂ emission from combustion of biomass fuels is not included in the total CO₂ emission data, since biomass fuels are considered CO₂ neutral. The CO₂ emission from biomass combustion is reported as a memo item in the Climate Convention reporting. In 2020, the CO₂ emission from biomass combustion was 16.2 Gg.

Time series for CO₂ emissions are provided in Figure 16.3.6. Since 1990 emission of CO₂ has decreased by 14.3 %. Fluctuations in CO₂ emission from AFF primarily regard fluctuations in fishing activities from year to year. Fluctuations in CO₂ emission from residential plants are largely a result of outdoor temperature variations from year to year. This also causes fluctuations in CO₂ emission from Energy Industries which cover electricity and heat production. However, the significant increase in emission from Energy Industries in 2010 continuing in 2011 is caused by the initiation of oil exploration in 2010, which is reported in the subsector "1.AA.1.c.ii Manufacture of Solid Fuels and Other Energy Industries". Since 2011 there has been no drilling for oil in Greenland.

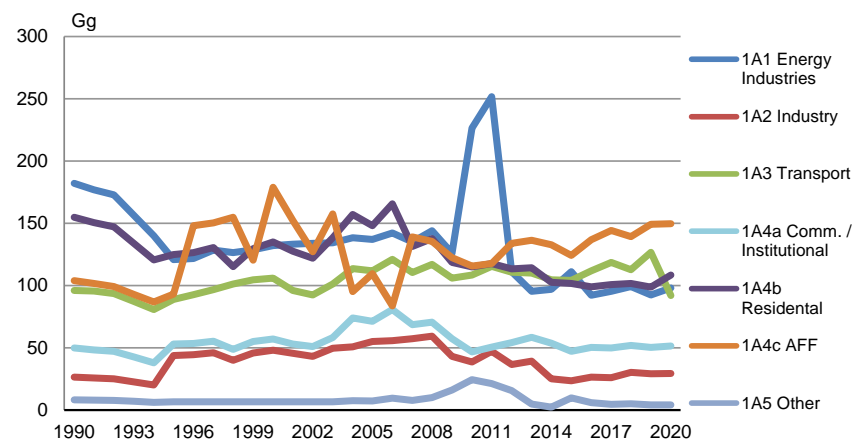

Figure 16.3.6 CO₂ Emission time series for Fuel Combustion (Sectoral Approach).

Detailed trend discussion on CRF category level is available in Section 16.2.

CH₄

CH₄ emission from fuel combustion accounts for 9.0 % of the Greenlandic CH₄ emission. Table 16.3.12 lists the CH₄ emission inventory for energy in 2020. The table reveals that residential plants accounted for 28.5 % of the CH₄ emission from energy in 2020. Agriculture, Forestry and Fisheries accounted for 19.8 %, and Energy Industries for 19.4 %.

Table 16.3.12 Emission of CH₄ from fuel combustion 2020.

	Mg	%
1A1 Energy Industries	10.1	19.4
1A2 Industry	0.8	1.6
1A3 Transport	8.6	16.6
1A4a Commercial / Institutional	7.1	13.5
1A4b Residential	14.9	28.5
1A4c Agriculture / Forestry / Fisheries	10.3	19.8
1A5 Other	0.3	0.5
1B Fugitive emissions from fuel	NO	NO
Total	52.0	100.0

Emission of CH₄ from fuel combustion has increased by 4.6 % since 1990. Time series for CH₄ emissions are provided in Figure 16.3.7. Fluctuations in CH₄ emission from AFF primarily regard fluctuations in fishing activities from year to year. Fluctuations in CH₄ emission from residential plants are largely a result of outdoor temperature variations from year to year. This also causes fluctuations in CH₄ emission from Energy Industries, which cover electricity and heat production and manufacture of solid fuels and other Energy Industries.

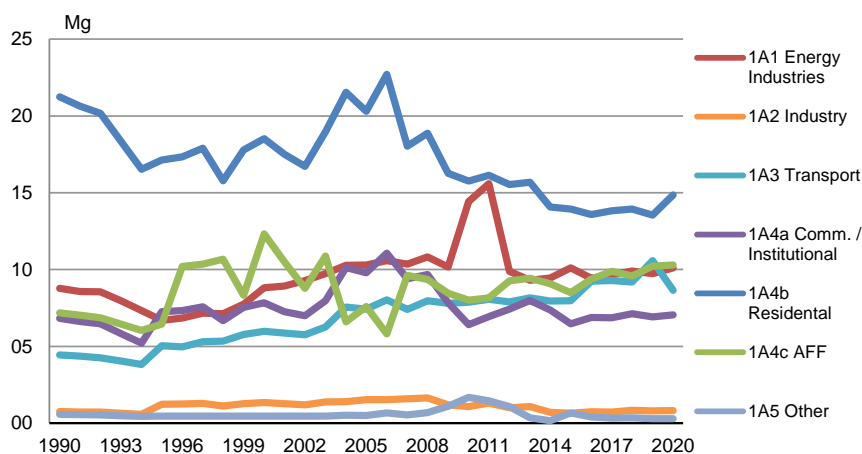

Figure 16.3.7 CH₄ emission time series for energy.

Detailed trend discussion on CRF category level is available in Section 16.2.

N₂O

Emission of N₂O from fuel combustion accounts for 23.1 % of the Greenlandic N₂O emission. Table 16.3.13 lists the N₂O emission inventory for energy in 2020. The table reveals that Transportation accounts for 47.4 % of the N₂O emission from the energy sector while Energy Industries accounted for 19.0 % of the emissions in 2020.

Table 16.3.13 Emission of N₂O from fuel combustion 2020.

	Mg	%
1A1 Energy Industries	1.6	19.0
1A2 Industry	0.2	2.9
1A3 Transport	4.0	47.4
1A4a Commercial / Institutional	0.4	5.0
1A4b Residential	0.9	10.6
1A4c Agriculture / Forestry / Fisheries	1.2	14.7
1A5 Other	0.0	0.4
1B Fugitive emissions from fuel	NO	NO
Total	8.4	100.0

Figure 16.3.8 shows the time series for the N₂O emission from energy. N₂O emission has increased by 6.9 % from 1990 to 2020 due to an increase in the use of recovered energy from waste simultaneously to a decrease in the consumption of liquid fuels.

Once again, the 2010 and 2011 increases in N₂O emission from Energy Industries are predominantly caused by the startup of oil explorative activities, while the decrease of N₂O emission since 2011 is due to a continuing standstill in oil explorations.

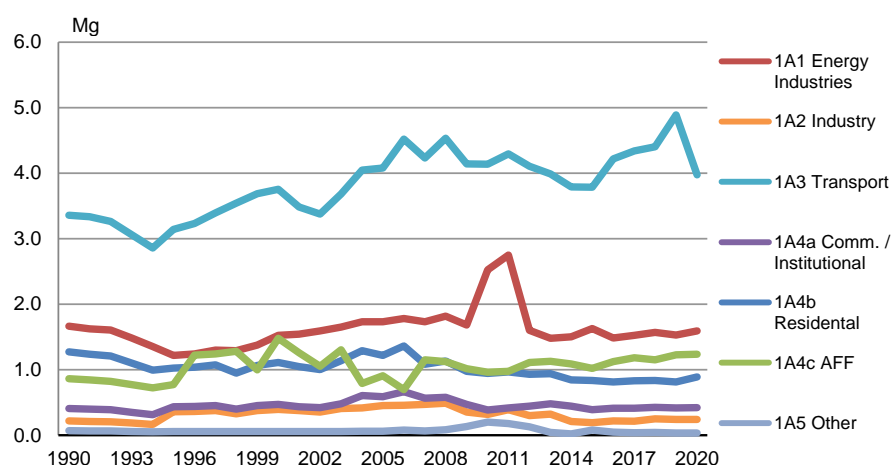

Figure 16.3.8 N₂O emission time series for energy.

Detailed trend discussion on CRF category level is available in Section 16.2.

SO₂, NO_x, NMVOC and CO

The emissions of SO₂, NO_x, NMVOC and CO from energy in 2020 are presented in Table 16.3.14. SO₂ from energy accounts for 99.0 % of the Greenlandic SO₂ emission. NO_x, CO and NMVOC account for 99.4 %, 87.5 % and 84.9 % respectively, of the Greenlandic emissions for these substances.

Table 16.3.14 Emission of SO₂, NO_x, NMVOC and CO from fuel combustion 2020.

	NO _x	CO	NMVOC	SO ₂
	Gg	Gg	Gg	Gg
1A1 Fuel consumption, Energy Industries	0.3	0.0	0.0	0.2
1A2 Fuel consumption, Manuf. Industries and Constr.	0.1	0.0	0.0	0.1
1A3 Fuel consumption, Transport	1.0	2.4	0.5	0.1
1A4 Fuel consumption, Other sectors	2.8	2.2	0.4	0.6
1B Fugitive emissions from fuel	NO	NO	NO	NO
Total emission from fuel consumption and fugitive emissions from fuel	4.2	4.6	0.9	1.0
Greenlandic emission	4.2	5.3	1.1	1.0
	%			
Emission share for fuel consumption	99.0	87.5	84.9	99.4

16.3.5 Uncertainties

A tier 1 uncertainty assessment has been carried out in accordance with the IPCC Guidelines (IPCC, 2006). The uncertainty has been estimated for all sources included in the reporting for the energy sector. The uncertainties for the activity data and emission factors are shown in Table 16.3.15.

Table 16.3.15 Uncertainties for activity data and emission factors for the energy sector.

Subsector	Pollutant	Activity data uncertainty	Emission factor uncertainty
1A Liquid fuels	CO ₂	3	2
1A Municipal waste	CO ₂	3	25
1B2 Oil exploration	CO ₂	3	1 000
1A Liquid fuels	CH ₄	3	100
1A Municipal waste	CH ₄	3	100
1A Biomass	CH ₄	3	100
1B2 Oil exploration	CH ₄	3	1 000
1A Liquid fuels	N ₂ O	3	500
1A Municipal waste	N ₂ O	3	500
1A Biomass	N ₂ O	3	200
1B2 Oil exploration	N ₂ O	3	1 000

With regard to uncertainty, the CO₂ emission factors are considered the most certain. Due to a technical analysis a country specific emission factor is available on the Greenlandic gasoil; the dominating liquid fuel. Consequently, the CO₂ emission factor uncertainty has been revised from 5 % to 2 % for liquid fuels. This revision was done in the 2014 submission.

To account for the more inhomogeneous nature of municipal waste the emission factor uncertainty has been set to 25 %. For CH₄ the emission factor uncertainty has been set to 100 % in accordance with the IPCC Guidelines (IPCC, 2006). For N₂O the emission factor uncertainties have been estimated between 200 % and 500 %. This is based on a first estimate and can be improved upon in the future.

Oil exploration has occurred in 2010 and 2011, but not since. However, fugitive emissions have been set to NA due to the fact that it has been impossible to obtain any information on the amount of oil and gas picked up during drillings in 2010 and 2011.

The resulting uncertainties for the individual greenhouse gases and the total uncertainty on the greenhouse gas emission are shown in Table 16.3.16.

Table 16.3.16 Uncertainties for the emission estimates.

	Uncertainty %	Trend 1990-2020 %	Trend uncertainty %
GHG	± 4.1	-14.2	± 3.6
CO ₂	± 3.6	-14.3	± 3.6
CH ₄	± 88	4.6	± 12.9
N ₂ O	± 449	6.9	± 47.4

16.3.6 Source specific QA/QC

The elaboration of a formal QA/QC plan is to be completed.

However, the official Greenland energy statistics is continuously going through a great deal of quality work with regard to accuracy, comparability and completeness. Statistics Greenland is responsible for the official Greenlandic energy statistics, and as such responsible for the completeness of data. The uncertainties connected with estimating fuel consumption do not influence the coherence between the energy statistics and the datasets used in the emission inventory submission. For the remainder of the datasets, it is assumed that the level of uncertainty is relatively small. See chapter regarding uncertainties for further comments.

Statistics on fuel consumption is reported by Statistics Greenland in form of a spreadsheet. Annual consumption of gasoil, kerosene, gasoline and LPG are divided into business categories and private households. To ensure consistency data are compared with those from previous years and large discrepancies are checked.

All external data used for the emission inventory submission are archived in spreadsheets. Data are archived annually in order to ensure that the basic data for a given report are always available in their original form.

Safely stored and quality checked activity data are then processed by using a methodological approach consistent with international guidelines.

Calculated emission factors are compared with guideline emission factors to ensure that they are reasonable. The calculations follow the principle in international guidelines.

During data processing, it is checked that calculations are being carried out correctly. However, a documentation plan for this is to be elaborated.

Time-series for activity data, emission factors and calculated emissions are used to identify possible errors in the calculation procedure. In fact, during the calculation, numerous controls take place to ensure correctness. Sums are checked of the various stages in the calculation procedure. Implied emission factors are compared to emission factors.

Every single time-series imported to the CRF Reporter is checked for fuel rate, units for fuel rate, emission factor and plant-specific emissions. Additional checks are performed on the database. The database encloses every single activity data, emission factors, emission, notation key and comment imported to the CRF Reporter. In other words, no information is typed manually into the CRF Reporter. Instead, all information is imported to the CRF Reporter through an XML-file to ensure maximum accuracy and completeness.

Reference approach

In addition to the sector-specific CO₂ emission inventories (the Greenlandic approach), the CO₂ emission is also estimated using the reference approach described in the IPCC Reference manual (IPCC, 2006). The reference approach is based on data for fuel production, import, export and stock change. The CO₂ emission inventory based on the reference approach is reported to the Climate Convention and used for verification of the official data in the Greenlandic approach.

Data on import, export and stock change used in the reference approach originate from the annual “basic data” table prepared by Statistics Greenland. The fraction of carbon oxidised has been assumed to be 1.00. The carbon emission factors are default factors originating from the IPCC Reference Manual (IPCC, 2006). The country-specific emission factors are not used in the reference approach, the approach being for the purposes of verification.

The Climate Convention reporting tables include a comparison of the Greenlandic approach and the reference approach estimates. To make results comparable, the CO₂ emission from incineration of the plastic content of municipal waste is added in the reference approach while the fuel consumption is subtracted.

In 2020 fuel consumption rates in the two approaches differ by 0 % and the CO₂ emission differs by 0.3 %. In the period 1990-2020 the CO₂ emission differs by 0.3 % or less at all times. The differences in energy consumption are 0 % for all years. According to IPCC Good Practice Guidance (IPCC, 2000) the difference should be within 2 %. A comparison of the Greenlandic approach and the reference approach is illustrated in Figure 16.3.9.

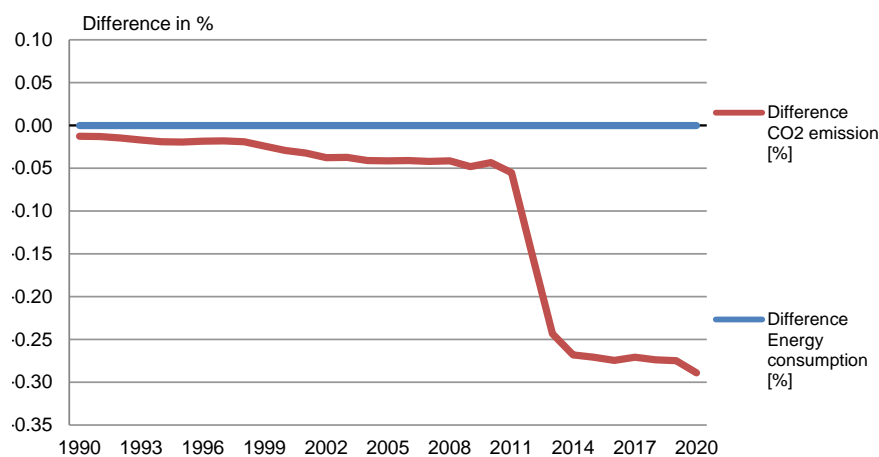

Figure 16.3.9 Comparison of the reference approach and the national approach.

16.3.7 Source specific recalculations and improvements

In this 2022 submission, there have been minor revisions in the energy sector, primarily with regard to the years 2013-2019. These revisions are caused by an update in the CO₂ emission factors with regard to kerosene, fueloil, wasteoil and the fossil fuel part of municipal waste according to Table 16.3.6. For 2018, there has been a minor change in the activity data.

Table 16.3.17 shows recalculations in the energy sector compared to the 2021 submission. Minor changes occur.

Table 16.3.17 Changes in GHG emission in the energy sector compared to the 2021 submission.

	1990	1991	1992	1993	1994	1995	1996	1997	1998	1999
Previous inventory, Gg CO ₂ eqv.	625.2	610.4	596.2	545.9	495.7	534.3	597.1	617.8	596.5	594.3
Recalculated, Gg CO ₂ eqv.	625.2	610.4	596.2	546.0	495.7	534.3	597.1	617.8	596.5	594.3
Change in Gg CO ₂ eqv.	0.0	0.0	0.0	0.0	0.0	0.0	0.0	0.0	0.0	0.0
Change in pct.	0.0	0.0	0.0	0.0	0.0	0.0	0.0	0.0	0.0	0.0
<i>continued</i>	2000	2001	2002	2003	2004	2005	2006	2007	2008	2009
Previous inventory, Gg CO ₂ eqv.	668.0	618.2	579.8	650.2	640.5	644.6	663.1	653.9	678.7	593.3
Recalculated, Gg CO ₂ eqv.	668.0	618.2	579.8	650.2	640.5	644.7	663.1	653.9	678.7	593.3
Change in Gg CO ₂ eqv.	0.0	0.0	0.0	0.0	0.0	0.0	0.0	0.0	0.0	0.0
Change in pct.	0.0	0.0	0.0	0.0	0.0	0.0	0.0	0.0	0.0	0.0
<i>continued</i>	2010	2011	2012	2013	2014	2015	2016	2017	2018	2019
Previous inventory, Gg CO ₂ eqv.	679.6	726.3	578.9	561.6	520.9	524.0	525.1	542.3	548.2	553.8
Recalculated, Gg CO ₂ eqv.	679.6	726.4	579.4	562.7	522.0	525.1	526.3	543.5	544.1	555.0
Change in Gg CO ₂ eqv.	0.0	0.1	0.6	1.1	1.1	1.1	1.1	1.1	-4.1	1.2
Change in pct.	0.0	0.0	0.1	0.2	0.2	0.2	0.2	0.2	-0.7	0.2
<i>continued</i>	2020									
Previous inventory, Gg CO ₂ eqv.	-									
Recalculated, Gg CO ₂ eqv.	536.7									
Change in Gg CO ₂ eqv.	-									
Change in pct.	-									

16.3.8 Source specific planned improvements

Some planned improvements to the emission inventories are discussed below.

1) Memo Items, International Aviation Bunkers

Previously, emissions from international aviation bunkers have been considered to be of negligible importance in terms of Greenland. For that matter the annual amount of jet fuel loaded into foreign aircrafts has been included as part of the IPCC category 1A3a Domestic Aviation. However, some misunderstanding has taken place and this assumption seems to be incorrect! New data has emerged regarding the distinction between domestic and international flights, and it now seems possible that combustion of jet fuel in international bound aircrafts taking off from Greenland can be determined and reported as international aviation bunkers as from the 2019 submission. However, in this 2022 submission jet fuel loaded into foreign aircrafts is still included as part of the IPCC category 1A3a Domestic Aviation.

2) Improved documentation for emission factors

The reporting of, and references for, the applied emission factors have been improved in the current year and will be further developed in future inventories. This will happen on the advice from the Danish National Environmental Research Institute.

3) Improvements in plant specific fuel combustion

Plant specific fuel combustion will be further improved according to the developments made by Statistics Greenland in the energy statistics.

4) Uncertainty estimates

Uncertainty estimates are largely based on the default uncertainty levels for activity rates and emission factors. More country-specific uncertainty estimates will be incorporated in future inventories.

5) Country specific emission factors

Statistics Greenland has acquired a technical analysis on the gasoil that is imported to and used in Greenland. The technical analysis conducted by the Danish Technical Institute has provided a country specific emission factor on the Greenlandic gasoil. Due to this technical analysis a new country specific emission factor on gas oil was implemented as from the 2014 submission. The arctic grade gas oil stands for 77.8 % of all liquid fuels in 2020.

The plan is to obtain additional country specific emission factors on other liquid fuels, but only if the UNFCCC recommend it as in the case of the Greenlandic gasoil.

16.3.9 References

Astrup, T., Larsen, A. W., Fuglsang, K. & Pedersen, N. H., 2012: PSO-0213, Biogenic Carbon in Danish Combustible Waste. DTU 2012. In press.

Consulting Company Carl Bro, 1996: Survey on waste from private households and companies in Greenland.

Consulting Company Carl Bro, 2001: Survey on waste from private households and companies in Greenland.

IPCC, 1997: Revised 1996 IPCC Guidelines for National Greenhouse Gas inventories. Available at:

<http://www.ipcc-nggip.iges.or.jp/public/gl/invs6.htm> (15-04-2007).

IPCC, 2000: Penman, J., Kruger, D., Galbally, I., Hiraishi, T., Nyenzi, B., Emmanuel, S., Buendia, L., Hoppaus, R., Martinsen, T., Meijer, J., Miwa, K. & Tanabe, K. (Eds). Good Practice Guidance and Uncertainty Management in National Greenhouse Gas Inventories. Published: IPCC/OECD/-IEA/IGES, Hayama, Japan. Available at:

<http://www.ipcc-nggip.iges.or.jp/public/gp/english/> (15-04-2007).

IPCC, 2006: 2006 IPCC Guidelines for National Greenhouse Gas Inventories, Prepared by the National Greenhouse Gas Inventories Programme, Eggleston H.S., Buendia L., Miwa K., Ngara T. & Tanabe K. (eds). Published: IGES, Japan. Available at:

<http://www.ipcc-nggip.iges.or.jp/public/2006gl/index.html> (21-02-2014).

EMEP/EEA, 2019: Air emission inventory guidebook, prepared by the UNECE/EMEP Task Force on Emission Inventories and Projections, 2016 update. Available at:

<https://www.eea.europa.eu/publications/emep-eea-guidebook-2019> (07-01-2020).

KEMIN, 2008: Ministry of Climate and Energy. Law on CO₂ quotas, nr. 348 of 09/05/2008. (Danish legislation). Available (in Danish) at:

<https://www.retsinformation.dk/Forms/R0710.aspx?id=117147> (2009-03-01).

Nielsen M., Nielsen, O.-K. & Thomsen, M. 2010: Emissions from decentralised CHP plants 2007 - Energinet.dk Environmental project no. 07/1882. Project report 5 - Emission factors and emission inventory for decentralised CHP production. National Environmental Research Institute, Aarhus University. 113 pp. - NERI Technical report No. 786. Available at: <http://www.dmu.dk/Pub/FR786.pdf> (2011-02-28).

Nielsen, O.-K., Plejdrup, M.S., Winther, M., Nielsen, M., Gyldenkerne, S., Mikkelsen, M.H., Albrektsen, R., Thomsen, M., Hjelgaard, K., Fauser, P., Bruun, H.G., Johannsen, V.K., Nord-Larsen, T., Vesterdal, L., Stupak, I., Scott-Bentsen, N., Rasmussen, E., Petersen, S.B., Olsen, T.M. & Hansen, M.G. 2021. Denmark's National Inventory Report 2021. Emission Inventories 1990-2019 - Submitted under the United Nations Framework Convention on Climate Change and the Kyoto Protocol. 944 pp. - Scientific Report from DCE - Danish Center for Environment and Energy no. 437. Available at: <https://dce2.au.dk/pub/SR437.pdf>

Pulles, T. & Aardenne, J.v. 2004: Good Practice for CLRTAP Emission Inventories, 24. June 2004. Available at: [http://www.eea.europa.eu/publications/EMEPCORINAIR4/BGPG.pdf\(2009-02-27\)](http://www.eea.europa.eu/publications/EMEPCORINAIR4/BGPG.pdf(2009-02-27)).

Statistics Greenland: Energy Consumption in Greenland 2020 published in Danish. Available at: <https://stat.gl/publ/da/EN/202102/pdf/2020%20Gr%C3%B8nlands%20energiforbrug.pdf> as "Grønlands energiforbrug 2020" in Danish only (13-12-2021).

16.4 Industrial Processes and Product Use (CRF sector 2)

16.4.1 Overview of sector

In this chapter the emissions of greenhouse gases from industrial processes and product use, not related to generation of energy, are presented.

The emission of greenhouse gases from industrial processes and product use includes CO₂, HFCs and SF₆. The emissions are reported in CRF Tables 2(I), 2(I).A, 2(II) and 2(II).B. Furthermore, the emission of non-methane volatile organic compounds (NMVOC) and CO from industrial processes related to asphalt roofing, road paving with asphalt and production of food and drink are given in CRF Table 2(I). This section also includes the emissions of CO₂ and NMVOC from use of solvents in industrial processes and households that are related to the former source categories Paint application, degreasing and dry cleaning, chemical products, manufacture and processing and others. Emission of CO₂ and NMVOC from solvent use are reported in CRF Tables 2(I) and 2(I).A.

Solvents are chemical compounds that are used on a global scale in industrial processes and as constituents in final products to dissolve e.g. paint, cosmetics, adhesives, ink, rubber, plastic, pesticides, aerosols or are used for cleaning purposes, i.e. degreasing. NMVOCs are main components in solvents - and solvent use in industries and households is typically the dominant source of anthropogenic NMVOC emissions. In industrial processes where solvents are produced or used NMVOC emissions to air and as liquid can be recaptured and either used or destroyed. Solvent containing products are used indoor and outdoor and the majority of solvent sooner or later evaporate. A small

fraction of the solvents ends up in waste or as emissions to water and may finally also contribute to air pollution by evaporation from these compartments.

In this section the methodology for the Greenland NMVOC emission inventory for solvent use is presented and the results for the period 1990-2020 are summarised. The method is based on the detailed approach described in EMEP/CORINAIR (2019) and emissions are calculated for the CRF sectors mentioned above.

An overview of sources identified is presented in Table 16.4.1 with an indication of the contribution to the industrial part of the emission of greenhouse gases in 2020. Emissions are extracted from the CRF tables.

Table 16.4.1 Overview of greenhouse gas sources 2020.

Process	IPCC Substance Code		Emission tonnes CO ₂ eqv.	%
Mineral Industry				
Limestone and Dolomite Use	2A4	CO ₂	109.50	0.8
Non-Energy Products of Fuels and Solvent use				
Paraffin Wax Use	2D2	CO ₂	418.82	3.0
Paraffin Wax Use	2D2	CH ₄	0.44	0.0
Paraffin Wax Use	2D2	N ₂ O	1.03	0.0
Solvent Use	2D3	CO ₂	324.94	2.4
Road Paving with Asphalt	2D3	CO ₂	0.29	0.0
Road Paving with Asphalt	2D3	CH ₄	0.14	0.0
Asphalt Roofing	2D3	CO ₂	0.13	0.0
Product uses as substitutes for ODS				
Refrigeration and Air Conditioning Equipment	2F1	HFCs	12 909.86	93.8
Other product manufacture and use				
Electrical Equipment	2G	SF ₆	2.55	0.0
Total emission			13 767.70	100.0

The subsector *Product uses as substitutes for ODS* (2F) constitutes 93.8 % of the industrial emission of greenhouse gases in 2020. This reflects the emission of HFCs from refrigeration and air conditioning equipment. The subsector *Non-Energy Products of Fuels and Solvent use* (2D) constitutes 5.4 % of the industrial emission of greenhouse gases. In this subsector we find emissions from paraffin wax use and solvents as well as road paving with asphalt and asphalt roofing. There has been an increased import of limestone and dolomite in 2019 and 2020. Limestone is used e.g. in cement and the production of concrete. Concrete is one of the common building materials in Greenland. The total emission of greenhouse gases (excl. LULUCF) in Greenland is estimated to 575.35 Gg CO₂ equivalents in 2020, of which industrial processes contribute with 13,768 Gg CO₂ equivalents (2.4 %). The emission of greenhouse gases from industrial processes from 1990-2020 are presented in Figure 16.4.1.

Greenland has no chemical industry, metal production or production of halo-carbons or SF₆. Greenland has no consumption of PFCs.

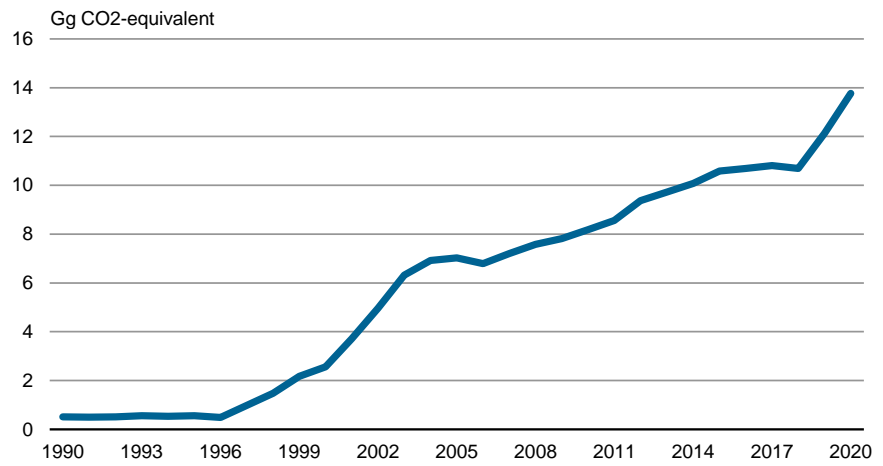

Figure 16.4.1 Emission of greenhouse gases from industrial processes 1990-2020.

The key category in the industrial sector *Consumption of Halocarbons* constitutes 2.2 % of the total emission of greenhouse gases in 2020. The trends in greenhouse gases from the industrial sector and subsectors are presented in Table 16.4.2. The emissions are extracted from the CRF tables.

Table 16.4.2 Emission of GHG from industrial processes and product use in different subsectors from 1990-2020.

	1990	1991	1992	1993	1994	1995	1996	1997	1998	1999
CO ₂ (tonnes CO ₂)										
A. Mineral Industry	NO	NO	NO	NO	NO	NO	NO	NO	NO	NO
D. Non-energy products from fuels and solvent use	514	500	507	542	507	531	399	558	697	789
CH ₄	0.0	0.0	0.0	0.0	0.0	0.0	0.0	0.0	0.0	0.0
N ₂ O	0.0	0.0	0.0	0.0	0.0	0.0	0.0	0.0	0.0	0.0
HFCs (tonnes CO ₂ eqv.)										
F. Product uses as ODS substitutes	NE	NE	NE	NE	0	27	33	87	421	781
PFCs (tonnes CO ₂ eqv.)										
F. Product uses as ODS substitutes	NO	NO	NO	NO	NO	NO	NO	NO	NO	NO
SF ₆ (tonnes CO ₂ eqv.)										
G. Other product manufacture and use	NE	NE	NE	NE	NE	NE	3.2	3.2	3.2	3.2
<i>continued</i>	2000	2001	2002	2003	2004	2005	2006	2007	2008	2009
CO ₂ (tonnes CO ₂)										
A. Mineral Industry	4.0	2.8	1.3	2.6	1.8	0.1	0.0	1.5	3.0	0.0
D. Non-energy products from fuels and solvent use	561	569	740	1 257	1 122	1 280	945	986	1 015	1 004
CH ₄	0.0	0.0	0.0	0.0	0.0	0.0	0.0	0.0	0.0	0.0
N ₂ O	0.0	0.0	0.0	0.0	0.0	0.0	0.0	0.0	0.0	0.0
HFCs (tonnes CO ₂ eqv.)										
F. Product uses as ODS substitutes	2 000	3 141	4 222	5 057	5 792	5 740	5 842	6 206	6 557	6 809
PFCs (tonnes CO ₂ eqv.)										
F. Product uses as ODS substitutes	NO	NO	NO	NO	NO	NO	NO	NO	NO	NO
SF ₆ (tonnes CO ₂ eqv.)										
G. Other product manufacture and use	3.1	3.1	3.1	3.0	3.0	3.0	2.9	2.9	2.9	2.9
<i>continued</i>	2010	2011	2012	2013	2014	2015	2016	2017	2018	2019
CO ₂ (tonnes CO ₂)										
A. Mineral Industry	4.9	0.0	19.6	0.0	6.6	0.0	0.1	3.2	39.9	130.3
D. Non-energy products from fuels and solvent use	895	876	940	763	805	812	696	718	909	884
CH ₄	0.0	0.0	0.0	0.0	0.0	0.0	0.0	0.0	0.0	0.0
N ₂ O	0.0	0.0	0.0	0.0	0.0	0.0	0.0	0.0	0.0	0.0
HFCs (tonnes CO ₂ eqv.)										
F. Product uses as ODS substitutes	7 282	7 681	8 406	8 962	9 261	9 772	9 994	10 078	9 733	11 108
PFCs (tonnes CO ₂ eqv.)										
F. Product uses as ODS substitutes	NO	NO	NO	NO	NO	NO	NO	NO	NO	NO
SF ₆ (tonnes CO ₂ eqv.)										
G. Other product manufacture and use	2.8	2.8	2.8	2.7	2.7	2.7	2.7	2.6	2.6	2.6
<i>continued</i>	2020									
CO ₂ (tonnes CO ₂)										
A. Mineral Industry	109.5									
D. Non-energy products from fuels and solvent use	744									
CH ₄	0.0									
N ₂ O	0.0									
HFCs (tonnes CO ₂ eqv.)										
F. Product uses as ODS substitutes	12 910									
PFCs (tonnes CO ₂ eqv.)										
F. Product uses as ODS substitutes	NO									
SF ₆ (tonnes CO ₂ eqv.)										
G. Other product manufacture and use	2.6									

Greenland has no production of halocarbons or SF₆. Data on consumption of F-gases (HFCs and SF₆) are obtained from the Statistics Greenland (imports) and by an annual survey on consumption halocarbons and SF₆. Information on consumption of F-gases is available from 1995 onwards. Greenland has no consumption of PFCs.

One single plant in Greenland had a stock of SF₆ ultimo 1995. The emission of SF₆ from this stock was 3.2 tonnes CO₂ equivalents in 1996. Since 1996 there has been an annually emission from this stock. However, there has been no consumption of SF₆ in Greenland.

In December 2015 Statistics Greenland acquired the following information from Nukissiorfiit; the main supplier of electricity and heat in Greenland: According to Nukissiorfiit the switchgears in all netstations were changed from regular switches without gas to gaseous switches containing SF₆ in 2002-2004. The new gaseous switchgears from Spanish Ormazabal are closed and sealed switches that do not need any filling of gas. For that reason the switchgears are considered to be completely tight with no leaks of gas. When Nukissiorfiit replace the gaseous Ormazabal switches the switchgears are returned directly to Ormazabal in Spain where the SF₆ within the switch are recycled.

Due to this information the Greenlandic switchgears in plants and netstations containing SF₆ are considered to be completely free from leaks from 2005 an onwards. This consideration is supported by the fact that Nukissiorfiit has not been buying any SF₆ for stockpiling or filling for many years and today has no record of any SF₆ in stock at all.

However, for the sake of good practice it has been decided to keep the SF₆-plant from 1995 within this material for 25 full years, which in 1995 was considered to be the lifetime of that specific switchgear. Due to that decision the plant and the estimated emission of SF₆ from that plant will be left in the material until 2020. From 2021 the plant will be deleted from the material as well as all emission from it. We hope that the UNFCCC team of reviewers will approve to this decision.

Energy consumption associated with industrial processes and emissions thereof are included in the Energy sector of the inventory.

16.4.2 Source category description

Mineral Industry

The subsector *Mineral Industry* (2A) covers the following processes:

- 2A4d Limestone and dolomite use.

Emission from limestone and dolomite use are presented in the CRF sector 2A.4d under 2A.4 Other Process Uses of Carbonates. The time series for the emission of CO₂ from Mineral industry (2A) is presented in Table 16.4.3. The emissions are extracted from the CRF tables and the values are rounded.

Table 16.4.3 Emission of CO₂ (tonnes) from Mineral Industry (2A).

	1990	1991	1992	1993	1994	1995	1996	1997	1998	1999
4d Limestone and dolomite use	-	-	-	-	-	-	-	-	-	-
<i>continued</i>	2000	2001	2002	2003	2004	2005	2006	2007	2008	2009
4d Limestone and dolomite use	4.0	2.8	1.3	2.6	1.8	0.1	0.0	1.5	3.0	0.0
<i>continued</i>	2010	2011	2012	2013	2014	2015	2016	2017	2018	2019
4d Limestone and dolomite use	4.9	0.0	19.6	0.0	6.6	0.0	0.1	3.2	39.9	130.3
<i>continued</i>	2020									
4d Limestone and dolomite use	109.5									

The use of limestone and dolomite started in 2000. Hence there is no emission from limestone and dolomite use before 2000. The use of limestone and dolo-

mite has been estimated from the annual import of these products to Greenland. Imports seem to vary a great deal from year to year, which causes the estimated use to vary as well. Import of dolomite has increased greatly from 2018 due to large-scale construction activities, primarily new airports, harbours etc.

The CO₂ emission from subsectors under Mineral Industry fluctuates a great deal from year to year, as seen in Figure 16.4.2. This is caused by fluctuations in activities from year to year. However fluctuations in CO₂ are primarily caused by the fact that activity data for Mineral Industry are based on import data, which do not allow distinction of imported amount into consumption and stockpiling.

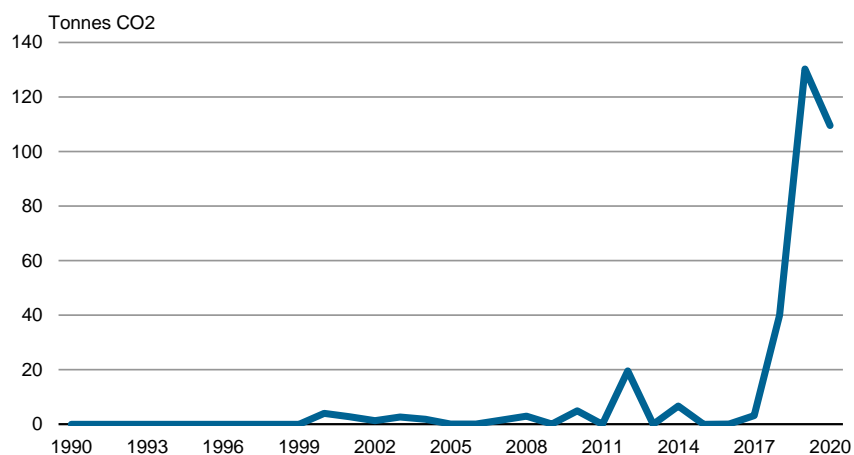

Figure 16.4.2 Emission of CO₂ from Mineral Industry.

Non-energy Products from Fuels and Solvent Use

The subsector *Non-energy Products from Fuels and Solvent Use* (2D) covers the following processes:

- 2D2 Paraffin Wax Use.
- 2D3 Solvent Use.
- 2D3 Road paving with asphalt.
- 2D3 Asphalt roofing.

Emissions from paraffin wax use are presented in the CRF 2D.2 subsector Paraffin Wax Use, while emissions from solvent use, road paving with asphalt and roof covering with asphalt materials are specified separately in the CRF 2D.3 subsector Other. The time series for the emission of CO₂ from Non-energy Products from Fuels and Solvent Use (2D) are presented in Table 16.4.4. The emissions are extracted from the CRF tables and the values are rounded.

Table 16.4.4 Emission of greenhouse gases from Non-energy Products from Fuels and Solvent Use (2D), tonnes CO₂ eqv.

	1990	1991	1992	1993	1994	1995	1996	1997	1998	1999
2. Paraffin Wax Use	251.6	241.3	250.3	279.8	232.0	254.6	189.7	295.6	426.9	480.0
3a. Solvent Use	263.4	259.7	257.4	262.5	275.6	276.7	209.3	263.4	271.0	310.1
3b. Asphalt roofing	0.2	0.2	0.2	0.2	0.2	0.2	0.2	0.2	0.2	0.3
3c. Road paving	0.1	0.1	0.1	0.1	0.1	0.1	0.1	0.1	0.1	0.1
Total	515.2	501.3	508.0	542.6	507.8	531.6	399.3	559.4	698.2	790.5
<i>continued</i>	2000	2001	2002	2003	2004	2005	2006	2007	2008	2009
2. Paraffin Wax Use	313.7	346.8	508.4	945.6	846.8	957.0	715.2	764.4	797.8	666.1
3a. Solvent Use	247.9	223.6	233.5	314.0	277.5	326.1	232.5	224.0	219.9	339.9
3b. Asphalt roofing	0.2	0.3	0.2	0.8	0.4	0.8	0.2	0.3	0.4	0.2
3c. Road paving	0.1	0.0	0.1	0.1	0.1	0.1	0.1	0.1	0.2	0.1
Total	561.9	570.8	742.2	1 260.5	1 124.7	1 284.0	948.1	988.8	1 018.3	1 006.3
<i>continued</i>	2010	2011	2012	2013	2014	2015	2016	2017	2018	2019
2. Paraffin Wax Use	684.1	654.8	710.6	539.2	573.9	598.9	446.2	506.8	517.1	455.0
3a. Solvent Use	213.4	223.3	231.2	224.9	232.6	214.3	251.0	212.7	393.6	430.5
3b. Asphalt roofing	0.2	0.5	0.2	0.4	0.3	0.8	0.8	0.6	0.2	0.3
3c. Road paving	0.1	0.1	0.1	0.1	0.1	0.1	0.1	0.1	0.1	0.1
Total	897.8	878.7	942.1	764.6	806.8	814.1	698.1	720.1	910.9	885.8
<i>continued</i>	2020									
2. Paraffin Wax Use	420.3									
3a. Solvent Use	324.9									
3b. Asphalt roofing	0.4									
3c. Road paving	0.1									
Total	745.8									

In 2020 the most significant emission of greenhouse gases came from the use of paraffin wax use which constituted 53.9 % of total emission from *Non-energy Products from Fuels and Solvent Use* that year. Emission of greenhouse gases from solvent use accounted for 36.1 % of total emission from this sub-sector in 2020, while emission from asphalt roofing and road paving constituted less than 0.0 in 2020.

Emission from subsectors under Non-energy Products from Fuels and Solvent Use fluctuates a great deal from year to year, as seen in Figure 16.4.3. This is among others caused by fluctuations in building activities and road paving. However fluctuations in emission are also caused by the fact that activity data for Non-energy Products and Solvent Use are based on import data, which do not allow distinction of imported amount into consumption and stockpiling.

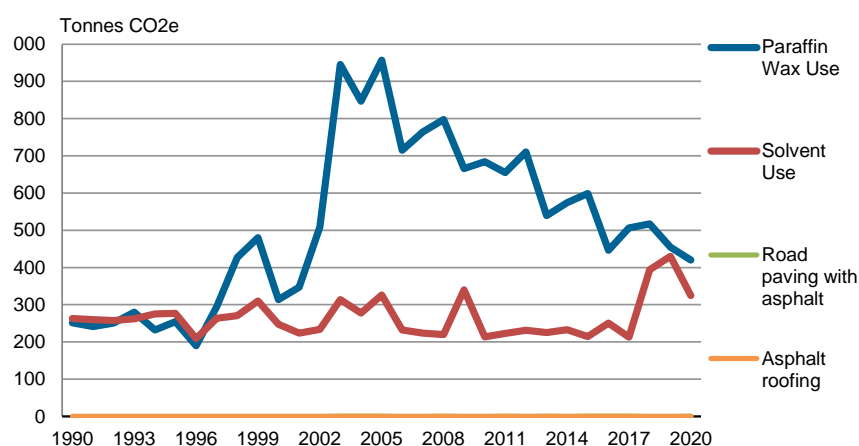

Figure 16.4.3 Emission of Greenhouse gases from Non-energy Products from Fuels and Solvent Use.

Product Uses as Substitutes for ODS – Consumption of Halocarbons

The subsector *Product Uses as Substitutes for ODS (2F)* includes the following source categories and the following halocarbons of relevance for Greenlandic emissions:

- 2F1 Refrigeration: HFC32, 125, 134a, 143a, unspecified HFCs.

A quantitative overview is given below for each of these source categories and each halocarbon, showing their emissions in tonnes through time. The data is extracted from the CRF tables that form part of this submission and the data presented is rounded values. It must be noticed that the inventories for the years 1990-1994 might not cover emissions of these gases in full. The chosen base-year for these gases is 1995 for Greenland.

Table 16.4.5 Emission of HFCs from refrigeration (t).

	1990	1991	1992	1993	1994	1995	1996	1997	1998	1999
HFC32	NE	NE	NE	NE	NE	NA	0.00	0.00	0.00	0.00
HFC125	NE	NE	NE	NE	NE	NA	0.00	0.04	0.07	0.13
HFC134a	NE	NE	NE	0.01	0.02	0.02	0.03	0.07	0.12	0.18
HFC143a	NE	NE	NE	NE	NE	NA	0.00	0.04	0.08	0.15
Unspecified HFCs	NE	NE	NE	NE	NE	NA	0.00	0.00	0.00	0.00
<i>continued</i>	2000	2001	2002	2003	2004	2005	2006	2007	2008	2009
HFC32	0.00	0.01	0.01	0.01	0.01	0.01	0.01	0.01	0.01	0.01
HFC125	0.19	0.31	0.42	0.50	0.57	0.57	0.58	0.62	0.67	0.70
HFC134a	0.24	0.35	0.48	0.56	0.65	0.63	0.63	0.63	0.59	0.55
HFC143a	0.22	0.35	0.47	0.56	0.64	0.64	0.65	0.70	0.76	0.80
Unspecified HFCs	0.00	0.00	0.00	0.00	0.00	0.00	0.00	0.00	0.00	0.00
<i>continued</i>	2010	2011	2012	2013	2014	2015	2016	2017	2018	2019
HFC32	0.01	0.01	0.01	0.01	0.01	0.01	0.01	0.01	0.00	0.00
HFC125	0.75	0.79	0.88	0.95	0.99	1.06	1.09	1.11	1.08	1.25
HFC134a	0.55	0.55	0.56	0.51	0.49	0.42	0.36	0.30	0.22	0.21
HFC143a	0.87	0.92	1.01	1.10	1.14	1.22	1.26	1.28	1.26	1.44
Unspecified HFCs	0.00	0.00	0.00	0.00	0.00	0.00	0.00	0.00	0.00	0.00
<i>continued</i>	2020									
HFC32	0.01									
HFC125	1.44									
HFC134a	0.30									
HFC143a	1.66									
Unspecified HFCs	0.00									

HFCs are used in various types of refrigeration in industry, retail, buildings and onboard ships. In 1993, 1994 and 1995 consumption of HFC134a was the only reported HFC used for refrigeration. Since 1996 consumption of HFC32, 125, 134A, 143A has been reported continuously. The emission of HFCs has increased a great deal since 1995. Emission of HFCs from refrigeration is shown in Figur 16.4.4.

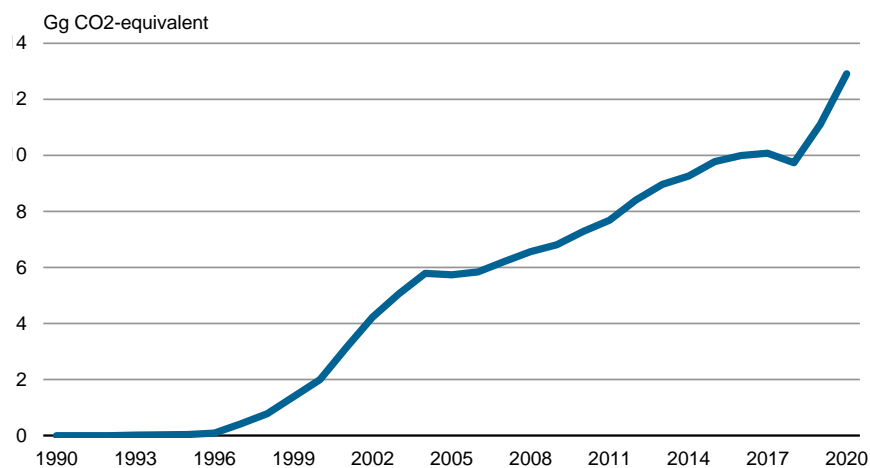

Figure 16.4.4 Emission of HFCs (from refrigeration).

Other Product Manufacture and Use – Consumption of SF₆

The subsector *Other Product Manufacture and Use* (2G) includes the following source categories and the following F-gases of relevance for Greenlandic emissions:

- 2G1 Electrical Equipment: SF₆.

Emissions of SF₆ are shown in Table 16.4.6 below. The data is extracted from the CRF tables that form part of this submission and the data presented is rounded values. It must be noticed that the inventories for the years 1990-1995 might not cover emissions of these gases in full. The chosen base-year for these gases is 1995 for Greenland.

Table 16.4.6 Emission of SF₆ from Electrical Equipment (kg).

	1990	1991	1992	1993	1994	1995	1996	1997	1998	1999
SF ₆	NE	NE	NE	NE	NE	1.50	0.14	0.14	0.14	0.14
<i>continued</i>	2000	2001	2002	2003	2004	2005	2006	2007	2008	2009
SF ₆	0.14	0.14	0.13	0.13	0.13	0.13	0.13	0.13	0.13	0.13
<i>continued</i>	2010	2011	2012	2013	2014	2015	2016	2017	2018	2019
SF ₆	0.12	0.12	0.12	0.12	0.12	0.12	0.12	0.12	0.11	0.11
<i>continued</i>	2020									
SF ₆	0.11									

The emission of SF₆ was highest in 1995, when one single plant in Greenland reported use of SF₆. The emission of SF₆ was 1.5 kg in 1995. Since 1995 the annual emission is assumed to be 0.5 % of the amount filled into the plant in 1995. This causes a relative high emission of SF₆ in 1995 and a much lower emission in the following years. In 2020 the emission of SF₆ was 0.11 kg. Emission of SF₆ from electrical equipment is shown in Figur 16.4.5.

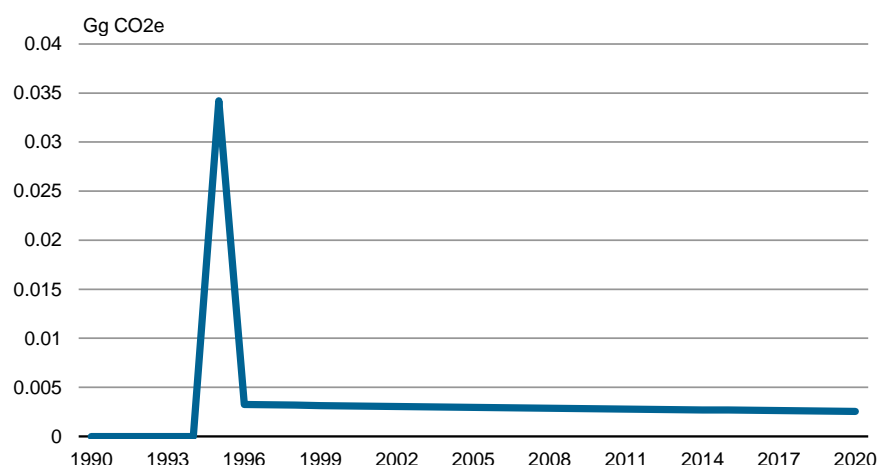

Figure 16.4.5 Emission of SF₆ (from electrical equipment).

Table 16.4.7 quantifies an overview of the emissions of the all F-gases in CO₂ eqv. from the two subsectors Product Uses as Substitutes for ODS (2F) and Other Product Manufacture and Use (2G). The emissions are extracted from the CRF tables and the values are rounded.

Table 16.4.7 Time series for emission of HFCs and SF₆ (tonnes CO₂ eqv.).

	1990	1991	1992	1993	1994	1995	1996	1997	1998	1999
HFCs	NE	NE	NE	NE	18	27	33	87	421	781
SF ₆	NE	NE	NE	NE	NE	34.2	34.2	3.2	3.2	3.2
<i>continued</i>	2000	2001	2002	2003	2004	2005	2006	2007	2008	2009
HFCs	2 000	3 141	4 222	5 057	5 792	5 740	5 842	6 206	6 557	6 809
SF ₆	3.1	3.1	3.1	3.0	3.0	3.0	2.9	2.9	2.9	2.9
<i>continued</i>	2010	2011	2012	2013	2014	2015	2016	2017	2018	2019
HFCs	7 282	7 681	8 406	8 962	9 261	9 772	9 994	10 078	9 733	11 108
SF ₆	2.8	2.8	2.8	2.7	2.7	2.7	2.7	2.6	2.6	2.6
<i>continued</i>	2020									
HFCs	12 910									
SF ₆	2.6									

HFCs is by far the most dominant group among the F-gases. HFCs constitute a key category both with regard to the key category level and the trend analysis.

Other

The subsector *Other* (2H) covers the following processes:

- 2H2 Food and Beverages Industry.

Emission of NMVOC from food and beverages industry is presented in the CRF sector 2H.2 Other. There is no emission of CO₂ from this source.

16.4.3 Methodological issues

General

The CO₂ emission from the use of limestone and dolomite, paraffin wax, asphalt materials used for roof covering and road paving has been estimated from the annual import of these products to Greenland.

The emissions of HFCs and SF₆ have been estimated from data on consumption of F-gases. Activity data includes annual imports and data on consump-

tion of halocarbons and SF₆ obtained from an annual survey among importers and consumers of F-gases.

The emission modelling of solvents is done by estimating the amount of (pure) solvents consumed (EMEP/CORINAIR, 2019). All relevant solvents are estimated, or at least those representing more than 90 % of the total NMVOC emission. The estimation and modelling is based on a detailed set of data on imports of chemicals and products to Greenland. Each chemical (NMVOC) and chemical containing product (group) is estimated separately. The sum of emissions of all estimated NMVOCs used as solvents equals the NMVOC emission from solvent use.

The following sections contain a description of activity data and emission factors used for the subsectors under industrial processes. The section is concluded by a description of the emissions of greenhouse gases from industrial processes and product use.

Activity data

Activity data for subsectors *Mineral Industry (2A)*, *Non-Energy Products of Fuel and Solvent Use (2D)* and *Other (2H)* are presented in Table 16.4.8. Activity data under subsector *Other (2H)* are used for calculation of emission of non-methane volatile organic compounds (NMVOC). Emission of non-methane volatile organic compounds (NMVOC) is also calculated from the use of solvents under subsector 2D.

The activity data are rounded. Notice that production of beer is given in hectolitre (hl). All other activity data are given in tonnes (t).

Statistics on imports are used to estimate annual consumption in mineral industry and the use of non-energy products of fuel and solvents.

The definitions of solvents and VOC that are used are as defined in the solvent directive (Directive 1999/13/EC) of the EU legislation: "Organic solvent shall mean any VOC which is used alone or in combination with other agents, and without undergoing a chemical change, to dissolve raw materials, products or waste materials, or is used as a cleaning agent to dissolve contaminants, or as a dissolver, or as a dispersion medium, or as a viscosity adjuster, or as a surface tension adjuster, or a plasticiser, or as a preservative". VOCs are defined as follows: "Volatile organic compound shall mean any organic compound having at 293.15 K a vapour pressure of 0.01 kPa or more, or having a corresponding volatility under the particular condition of use".

All the import data are collected by Statistics Greenland, the emission calculation based on the import data are performed by the Ministry of Industry and Labour.

Import figures of chemicals and chemical containing products are obtained from Statistics Greenland. There is no production or export of chemicals and chemical containing products, therefore the import amount is assumed to be equivalent to the used amount.

Statistics on imports of whole coffee beans and yeast for baking are used to estimate annual production of coffee and bread. Statistics on landings of fish and seafood to domestic plants are used to determine domestic processing of fish and seafood. Statistics on imports are produced by Statistics Greenland.

Production of beer including a fermentation process has taken place at the brewery "Godthåb Bryghus" since 2005 (Godthåb Bryghus, 2021). The brewery has reported annual production in rounded hectolitre. The much larger company "Nuuk Imeq" has no production of beer including a fermentation process. As a bottling company the activity at "Nuuk Imeq" only includes diluting of the concentrated quantities imported to Greenland and afterwards bottling of the beer.

Table 16.4.8 Activity data for Mineral Industry, Non-energy Products of Fuel and Solvent Use, and Other.

	1990	1991	1992	1993	1994	1995	1996	1997	1998	1999
Mineral Industry										
2A4d Limestone and dolomite use (t)	-	-	-	-	-	-	-	-	-	-
Non-energy Products from Fuels and Solvent Use										
2D2 Paraffin wax use (t)	86	83	86	96	79	87	65	101	146	164
2D3a Solvent use (t)	190	187	188	195	198	174	141	198	206	254
2D3b Road paving with asphalt (t)	591	581	595	604	597	577	532	664	649	752
2D3c Asphalt roofing (t)	136	210	236	280	234	238	292	249	258	246
Other Production, Food and Beverage Industry										
2H2 Beans roasted to produce coffee (t)	0	0	0	0	-	0	-	-	0	0
2H2 Production of bread (t)	356	346	339	358	501	244	415	500	847	689
2H2 Landings of fish and seafood (t)	81 768	72 396	65 554	59 423	64 428	67 751	60 666	62 249	67 250	63 753
2H2 Production of beer (hl)	-	-	-	-	-	-	-	-	-	-
<i>continued</i>	2000	2001	2002	2003	2004	2005	2006	2007	2008	2009
Mineral Industry										
2A4d Limestone and dolomite use (t)	9	6	3	6	4	0	0	3	7	0
Non-energy Products from Fuels and Solvent Use										
2D2 Paraffin wax use (t)	107	119	174	324	290	328	245	262	273	228
2D3a Solvent use (t)	159	155	196	264	271	351	291	258	209	329
2D3b Road paving with asphalt (t)	694	988	705	2 218	1 127	2 258	698	912	1 206	629
2D3c Asphalt roofing (t)	136	124	148	187	282	172	242	258	387	322
Other Production, Food and Beverage Industry										
2H2 Beans roasted to produce coffee (t)	0	1	-	0	0	0	0	1	0	0
2H2 Production of bread (t)	687	566	1 020	1 048	1 338	1 014	1 134	859	931	587
2H2 Landings of fish and seafood (t)	74 105	66 929	85 970	80 667	102 570	103 642	111 351	118 260	109 420	102 393
2H2 Production of beer (hl)	-	-	-	-	-	1 000	2 000	2 000	1 850	1 650
<i>continued</i>	2010	2011	2012	2013	2014	2015	2016	2017	2018	2019
Mineral Industry										
2A4d Limestone and dolomite use (t)	11	0	45	0	15	0	0	7	91	296
Non-energy Products from Fuels and Solvent Use										
2D2 Paraffin wax use (t)	234	224	243	185	197	205	153	174	177	156
2D3a Solvent use (t)	225	234	299	275	292	244	242	246	315	358
2D3b Road paving with asphalt (t)	443	1 529	583	1 200	824	2 445	2 444	1 736	617	988
2D3c Asphalt roofing (t)	292	220	151	169	194	168	238	216	212	150
Other Production, Food and Beverage Industry										
2H2 Beans roasted to produce coffee (t)	0	0	1	3	1	1	0	2	4	11
2H2 Production of bread (t)	790	584	563	567	606	985	433	683	424	553
2H2 Landings of fish and seafood (t)	97 955	104 020	112 239	109 452	108 416	109 368	129 925	120 891	118 324	123 032
2H2 Production of beer (hl)	2 010	2 115	2 080	1 985	1 628	1 800	3 810	2 450	3 430	1 315

Continued on next page...

<i>Continued</i>	2020	Source
Mineral Industry		
2A4d Limestone and dolomite use (t)	249	1
Non-energy Products from Fuels and Solvent Use		
2D2 Paraffin wax use (t)	144	1
2D3a Solvent use (t)	306	1
2D3b Road paving with asphalt (t)	1 261	1
2D3c Asphalt roofing (t)	318	1
Other Production, Food and Beverage Industry		
2H2 Beans roasted to produce coffee (t)	2	2
2H2 Production of bread (t)	382	2
2H2 Landings of fish and seafood (t)	118 225	3
2H2 Production of beer (hl)	1 211	4

The activity data on HFCs and SF₆ are obtained by annual registrations on import and export of HFCs and SF₆, and by annual surveys among importers, wholesalers and suppliers as well as consumers of HFCs and SF₆. This means that the obtaining of activity data includes the quantification and determination of any import and export of HFCs and SF₆ contained products and substances in stock form. This is in accordance with IPCC guidelines (IPCC, 2006), as well as the relevant decision trees from the IPCC Good Practice Guidance (IPCC, 2006).

The following sources of information have been used (Statistics Greenland):

- Importers, wholesaler and suppliers.
- Statistics Greenland.
- Consuming enterprises.

Importers and suppliers provide consumption data of F-gases. Emission factors are defaults from the GPG. Import/export data for sub-source categories where import/export is relevant are quantified on estimates from import/export statistics of products + default values of the amount of gas in the product.

The determination of emissions of F-gases is based on a calculation of the actual emission. The actual emission is the emission in the evaluation year, accounting for the time lapse between consumption and emission. The actual emission includes Greenlandic emissions from production and from products during their lifetimes. Consumption and emissions of F-gases are, whenever possible for individual substances, even though the consumption of certain HFCs has been limited. This has been varied out to ensure transparency of evaluation in the determination of GWP values. However, the continued use for Other HFCs has been necessary since not all importers and suppliers have specified records of sales for individual substances.

Only the actual emission has been calculated. Thus, the potential emission is assumed to be the same as the actual emission in the CRF tables.

Table 16.4.9 Content (w/w%) of “pure” HFC in HFC-mixtures, used as trade names.

HFC mixtures	HFC32	HFC125	HFC134a	HFC143a	Unspecified HFCs
	%	%	%	%	%
HFC-134, total			100		
HFC-404, total		44	4	52	
HFC-407c, total	23	25	52		
HFC-507a, total		50		50	
Unspecified HFCs					100

The substances have been accounted for in the survey according to their trade names, which are mixtures of HFCs used in the CRF. In the transfer to the “pure” substances used in the CRF reporting schemes, the ratios shown in Table 16.4.9 have been used.

The activity data expressed as total amount of HFCs and PFCs filled into new products, present in operating systems and remaining in products at decommissioning are included in the CRF tables and are not repeated here.

Heat pumps are part of category 2.F.1.a Commercial Refrigeration. There is however no production of heat pumps in Greenland and the stock of HFC-125 and HFC-134a and other HFCs in heat pumps therefore increase without any emission from manufacture.

Emission factors

The CO₂ emission factors applied for products in 2020 are presented in Table 16.4.10. The same emission factor has been applied for 1990-2020.

Table 16.4.10 CO₂ emission factors 2020.

Product	Emission factor	Unit	Reference	IPCC Category
Limestone and dolomite use	439.71	kg/t	IPCC, 2006	2A4d
Paraffin wax use	2 910	kg/t	Shires et al. (2004)	2D2
Asphalt used for road paving	0.23	kg/t	1	2D3b
Asphalt materials used for roofing	0.40	kg/t	1	2D3c

The CH₄ emission factors applied for products in 2020 are presented in Table 16.4.11. The same emission factor has been applied for 1990-2020.

Table 16.4.11 CH₄ emission factors 2020.

Product	Emission factor	Unit	Reference	IPCC Category
Paraffin wax use	0.121	kg/t	Shires et al. (2009)	2D2
Asphalt used for road paving	0.0044	kg/t	US EPA (2004)	2D3b

The N₂O emission factors applied for products in 2020 are presented in Table 16.4.12. The same emission factor has been applied for 1990-2020.

Table 16.4.12 N₂O emission factors 2020.

Product	Emission factor	Unit	Reference	IPCC Category
Paraffin wax use	0.024	kg/t	Shires et al. (2009)	2D2

The CO emission factors applied for the consumption of asphalt products in 2020 are presented in Table 16.4.13. The same emission factor has been applied for 1990-2020.

Table 16.4.13 CO emission factors 2020.

Product	Emission factor	Unit	Reference	IPCC Category
Asphalt used for road paving	0.1202	kg/t	US EPA (2004)	2D3b
Asphalt materials used for roofing	0.0095	kg/t	EMEP/EEA (2019)	2D3c

The NMVOC emission factors applied for the consumption of asphalt products and products used in the production of food and beverages in 2020 are presented in Table 16.4.14. The same emission factor has been applied for 1990-2020.

Table 16.4.14 NMVOC emission factors 2020.

Product	Emission factor	Unit	Reference	IPCC Category
Asphalt used for road paving	0.0016	kg/t	EMEP/EEA (2019)	2D3b
Asphalt materials used for roofing	0.130	kg/t	EMEP/EEA (2019)	2D3c
Food and Beverages Industry - Beans roasted to produce coffee	0.55	kg/t	IPCC, 1997	2H2
Food and Beverages Industry - Production of bread	8	kg/t	IPCC, 1997	2H2
Food and Beverages Industry - Landings of fish and seafood	0.3	kg/t	IPCC, 1997	2H2
Food and Beverages Industry - Production of beer	0.035	kg pr hl	IPCC, 1997	2H2

NMVOC-emissions from solvent use are estimated using emission modelling of solvents by estimating the amount of (pure) solvents consumed, thus representing a chemicals approach, where each pollutant is estimated separately. All relevant solvents must be estimated, or at least those together representing more than 90 % of the total pollutant emission. These emissions are summed up to one Greenlandic total CO₂ (NMVOC) emissions from solvent use.

Emission factors are calculated for a complete conversion to CO₂ of each NMVOC molecule in unit g CO₂ per g NMVOC from:

$$n \times 12 \frac{g}{mol} / (\text{molecular weight NMVOC}) \times 3.667 \frac{g CO_2}{g C}$$

where n is the number of carbon atoms in the NMVOC molecule. The default NMVOC-CO₂ conversion factor of $0.85 * 3.667 = 3.11$ is used for solvents.

The emission factors used in the Greenlandic inventory are the same as developed for the Danish inventory (please refer to Chapter 5).

16.4.4 Emissions

The greenhouse gas (GHG) emissions are listed in Table 16.4.15. The emission from industrial processes and product use accounts for 2.4 % of the Greenlandic GHG emission in 2020.

The CO₂ emission from industrial processes and product use accounts for just 0.16 % of the Greenlandic CO₂ emission (excluding net CO₂ emission from Land Use, Land Use Change and Forestry (LULUCF)). The HFC emission from industrial processes and product use accounts for 100 % of the Greenlandic emission and the SF₆ emission accounts for 100 % of the Greenlandic SF₆ emission.

Table 16.4.15 Greenhouse gas emission for the year 2020.

	CO ₂	HFC	SF ₆
	Tonne CO ₂ equivalent		
2A4 Limestone and Dolomite Use	109.50	NA	NA
2D2 Paraffin Wax Use	418.82	NA	NA
2D3 Solvent use	324.94	NA	NA
2D3 Road paving with asphalt	0.29	NA	NA
2D3 Asphalt roofing	0.13	NA	NA
2F1 Refrigeration and air conditioning	NA	12 910	NA
2G1 Electrical Equipment	NA	NA	2.6
Total emission from industrial processes and product use	636.21	12 910	2.6
Greenlandic emission (excluding net emission from LULUCF)	553 628	12 910	2.6
	%		
Emission share for industrial processes and product use	0.16	100.00	100.00

Note: Emission of CH₄ and N₂O has been omitted from Table 16.4.15 due to very low values of emission.

HFC is the most important GHG pollutant and accounts for 93.8 % of the GHG emission in CO₂ equivalents from industrial processes and product use. Illustration of the percentage of share in a figure is omitted due to the large share of HFC, which completely dominates as the most significant GHG pollutant from industrial processes.

CO₂

Figure 16.4.6 depicts the time series of CO₂ emission from industrial processes. As shown by the red curve total CO₂ emission follows the CO₂ emission from solvent use closely. The reason is that solvent use is such a dominant source to CO₂ emission within the sector *Industrial processes and product use*.

Data on imports are used to estimate annual use of paraffin wax use, solvent use, limestone and dolomite as well as asphalt for road paving and roofing. This causes a great deal of fluctuations from year to year. Hence, in years with none or low import of solvents, i.e. 2008, 2010 and onwards, CO₂ emission from solvent use are on a lower level.

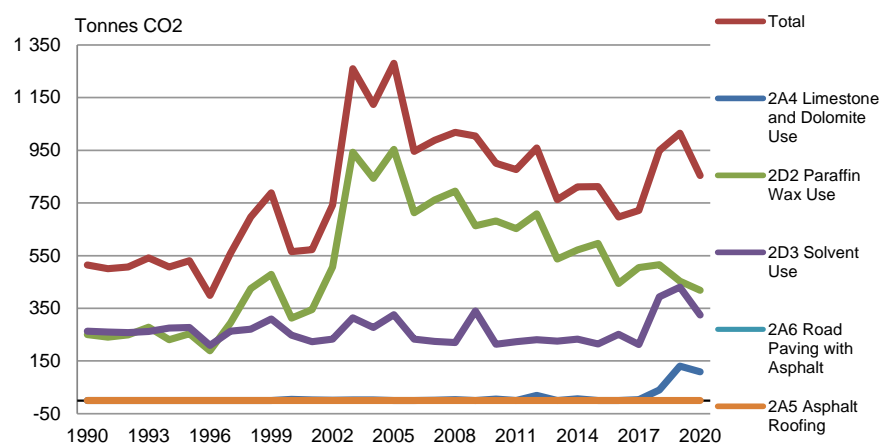

Figure 16.4.6 Emission of CO₂ from industrial processes and product use.

Emission of HFCs and SF₆ are illustrated in Figure 16.4.4 and Figure 16.4.5.

NMVOC and CO

The emissions of NMVOC and CO from industrial processes and product use in 2020 are presented in Table 16.4.16. NMVOC and CO account for 13.17 % and 0.003 % respectively, of the Greenlandic emissions for these substances.

Table 16.4.16 NMVOC and CO emission from industrial processes 2020.

		NMVOC	CO
		Tonnes	
2D3	Solvent Use	104.16	NA
2D3	Asphalt Roofing	0.04	0.00
2D3	Road Paving with Asphalt	0.02	0.15
2H2	Food and beverages industry	38.57	NA
Total emission from industrial processes and product use		142.79	0.15
Greenlandic emission		1 084.26	5 285.00
		%	
Emission share for industrial processes and product use		13.17	0.003

16.4.5 Uncertainties

A tier 1 uncertainty assessment has been carried out in accordance with the IPCC GPG (IPCC, 2006). The uncertainty has been estimated for all sources included in the reporting for industrial processes. The uncertainties for the activity data and emission factors are shown in Table 16.4.17.

Table 16.4.17 Uncertainties for activity data and emission factors for industrial processes.

Subsector	Pollutant	Activity data uncertainty	Emission factor uncertainty
2A4 Limestone and dolomite use	CO ₂	5	5
2D2 Paraffin wax use	CO ₂	5	25
2D3 Solvent use	CO ₂	5	25
2D3 Road paving with asphalt	CO ₂	5	25
2D3 Asphalt roofing	CO ₂	5	25
2D2 Paraffin wax use	CH ₄	5	25
2D3 Road paving with asphalt	CH ₄	5	25
2D2 Paraffin wax use	N ₂ O	5	25
2F Consumption of HFC	HFC	10	50
2G Consumption of SF ₆	SF ₆	10	50

The activity data comes from the import statistics, which is considered to be of high quality. Thus the uncertainty value of the activity data has been set to 5 % for limestone and dolomite use, paraffin wax use, solvent use and asphalt used for road paving and roofing. For consumption of HFCs and SF₆ the uncertainty value of the activity data has been set to 10 %.

With regard to uncertainty, the CO₂ emission factor for limestone and dolomite use is considered very certain. It is derived from stoichiometric calculations. Thus an emission factor of 5 % has been assumed. The uncertainty levels for paraffin wax use, solvent use, asphalt roofing and road paving are expert judgements set to 25 % for the emission factor. The emission of F-gases is dominated by emissions from refrigeration equipment and, therefore, the uncertainties assumed for this sector will be used for all the F-gases. The IPCC propose an uncertainty of 30-40 % for regional estimates. However, Greenlandic statistics have been developed over a number of years and, therefore the uncertainty on activity data is assumed to be 10 %. The uncertainty on the emission factor is, on the other hand, assumed to be 50 %. The base year for F-gases for Greenland is 1995.

The resulting uncertainties for the individual greenhouse gases and the total uncertainty on the greenhouse gas emission are shown in Table 16.4.18.

Table 16.4.18 Uncertainties for the emission estimates.

	Uncertainty %	Trend 1990-2020 ¹ %	Trend uncertainty %
GHG	± 48	2 264	± 1 142
CO ₂	± 16	66.0	± 9.3
HFC	± 51	38 964	± 5 524
SF ₆	± 51	-93	± 1.1

¹ For f-gases the base year of 1995 is used.

16.4.6 Source specific QA/QC

The elaboration of a formal QA/QC plan is to be completed.

However, the official Greenlandic import statistics has gone through a great deal of quality work with regard to accuracy, comparability and completeness. Statistics Greenland is responsible for the official Greenlandic import statistics, and as such responsible for the completeness of data. The import statistics is obtained by Statistic Greenland, which are used for emission for Industrial Processes and Product use.

Statistics on imports is reported by Statistics Greenland in form of a spreadsheet. Annual import of limestone and dolomite, paraffin wax use, asphalt materials used for roof covering and road paving, chemicals and chemical containing products, whole coffee beans and yeast for baking are compared with imports in previous years and large discrepancies are checked. The same procedure is used to ensure accuracy in annual use of F-gases and statistics on landings of fish and seafood to domestic plants.

All external data used for the emission inventory submission are archived in spreadsheets. Data are archived annually in order to ensure that the basic data for a given report are always available in their original form.

Safely stored and quality checked activity data are then processed by using a methodological approach consistent with international guidelines.

Calculated emission factors are compared with guideline emission factors to ensure that they are reasonable. The calculations follow the principle in international guidelines.

During data processing, it is checked that calculations are being carried out correctly. However, a documentation plan for this needs to be elaborated.

Time series for activity data, emission factors and calculated emissions are used to identify possible errors in the calculation procedure. In fact, during the calculation, numerous controls take place to ensure correctness. Sums are checked in the various stages in the calculation procedure. Implied emission factors are compared to emission factors.

Every single time series imported to the CRF Reporter is checked for annual activity, units for activity, emission factor and emissions. Additional checks are performed on the database. The database encloses every single activity data, emission factors, emission, notation key and comment imported to the CRF Reporter.

16.4.7 Source specific recalculations and improvements

In this 2022 submission there has been some revisions in the industrial processes and product use sector. These revisions are caused by the fact that emission of CH₄ and N₂O is now also calculated for the use of paraffin wax use, and CH₄ emission is now also calculated for Road Paving with Asphalt. Activity data has been revised with regard to catches of fish, shellfish and alike. Activity data has also been updated with regard to consumption of HFCs and SF₆, and a new program for estimating emission from HFCs and SF₆ has been developed and taken in use for the entire period.

Table 16.3.19 shows recalculations in the industrial processes and product use sector compared to the 2021 submission. Some changes occur.

Table 16.4.19 Changes in GHG emission in Industrial Processes and Product Use compared to the 2021 submission.

	1990	1991	1992	1993	1994	1995	1996	1997	1998	1999
Previous inventory, Gg CO ₂ eqv.	0.3	0.3	0.3	0.3	0.3	0.4	0.3	0.8	1.2	1.9
Recalculated, Gg CO ₂ eqv.	0.5	0.5	0.5	0.6	0.5	0.6	0.5	1.0	1.5	2.2
Change in Gg CO ₂ eqv.	0.2	0.2	0.2	0.3	0.2	0.2	0.2	0.2	0.3	0.3
Change in pct.	68.3	66.7	69.4	80.7	60.8	57.1	46.9	27.5	25.6	15.1
<i>continued</i>	2000	2001	2002	2003	2004	2005	2006	2007	2008	2009
Previous inventory, Gg CO ₂ eqv.	2.5	3.8	4.9	6.0	6.8	6.9	6.8	7.4	7.9	8.0
Recalculated, Gg CO ₂ eqv.	2.6	3.7	5.0	6.3	6.9	7.0	6.8	7.2	7.6	7.8
Change in Gg CO ₂ eqv.	0.1	0.0	0.1	0.3	0.1	0.1	0.0	-0.2	-0.3	-0.2
Change in pct.	2.8	-1.2	1.5	4.6	2.1	1.9	-0.2	-2.1	-3.6	-2.3
<i>continued</i>	2010	2011	2012	2013	2014	2015	2016	2017	2018	2019
Previous inventory, Gg CO ₂ eqv.	8.1	8.5	8.7	9.3	8.9	10.5	10.2	8.4	9.4	10.7
Recalculated, Gg CO ₂ eqv.	8.2	8.6	9.4	9.7	10.1	10.6	10.7	10.8	10.7	12.1
Change in Gg CO ₂ eqv.	0.1	0.0	0.6	0.4	1.2	0.1	0.5	2.4	1.3	1.4
Change in pct.	1.0	0.5	7.1	4.5	13.7	0.9	4.8	29.2	13.9	13.3
<i>continued</i>	2020									
Previous inventory, Gg CO ₂ eqv.	-									
Recalculated, Gg CO ₂ eqv.	13.8									
Change in Gg CO ₂ eqv.	-									
Change in pct.	-									

16.4.8 Source specific planned improvements

Some planned improvements to the emission inventories are discussed below.

1) Distribution of unspecified mix of HFCs into single HFCs

An unspecified mix of HFCs is used in commercials and industries. In future inventories attempts will be made in order to distribute the unspecified mix of HFCs into single substances.

It will be investigated whether use of N₂O from solvents is occurring in Greenland.

16.4.9 References

Godthåb Bryghus (Brewery in Nuuk), 2021: Data on production of beer 2006-2020. Not published.

EMEP/EEA, 2016: EMEP/EEA air pollutant emission inventory guidebook 2016, Technical guidance to prepare national emission inventories. Published by the EEA with the CLRTAP Task Force on Emission Inventories and Projec-

tions responsible for the technical content of the chapters. Technical report No 21/2016. Available at:

<https://www.eea.europa.eu/publications/emep-eea-guidebook-2016> (14/01-2021).

EMEP/EEA, 2019: EMEP/EEA air pollutant emission inventory guidebook 2019, Technical guidance to prepare national emission inventories. Published by the EEA with the CLRTAP Task Force on Emission Inventories and Projections responsible for the technical content of the chapters. Technical report No 13/2019. Available at:

<https://www.eea.europa.eu/publications/emep-eeaguidebook-2019> (8/12-2020).

Directive 1999/13/EC of 11 March 1999 on the limitation of emissions of volatile organic compounds due to the use of organic solvents in certain activities and installations, Brüssel, 1999.

IPCC, 1997: Revised 1996 IPCC Guidelines for National Greenhouse Gas inventories. Available at:

<http://www.ipcc-nggip.iges.or.jp/public/gl/invs6.htm> (15-04-2007).

IPCC, 2000: Penman, J., Kruger, D., Galbally, I., Hiraishi, T., Nyenzi, B., Emmanuel, S., Buendia, L., Hoppaus, R., Martinsen, T., Meijer, J., Miwa, K. & Tanabe, K. (Eds). Good Practice Guidance and Uncertainty Management in National Greenhouse Gas Inventories. Published: IPCC/OECD/-IEA/IGES, Hayama, Japan. Available at:

<http://www.ipcc-nggip.iges.or.jp/public/gp/english/> (15-04-2007).

IPCC, 2006: 2006 IPCC Guidelines for National Greenhouse Gas Inventories, Prepared by the National Greenhouse Gas Inventories Programme, Eggleston H.S., Buendia L., Miwa K., Ngara T. & Tanabe K. (eds). Published: IGES, Japan. Available at:

<http://www.ipcc-nggip.iges.or.jp/public/2006gl/index.html> (21-02-2014).

IPCC, 2007: Climate Change 2007. The Physical Science Basis. Contribution of Working Group I to the Fourth Assessment report of the Intergovernmental Panel on Climate Change [Solomon, S., D. Qin, M. Manning, Z.Chen. M. Marquis, K.B. Averyt, M. Tignor & H.L. Miller (eds.)]. Cambridge University Press, Cambridge, United Kingdom and New York, NY, USA 996 pp.

Nielsen, O.-K., Plejdrup, M.S., Winther, M., Nielsen, M., Gyldenkerne, S., Mikkelsen, M.H., Albrektsen, R., Thomsen, M., Hjelgaard, K., Fauser, P., Bruun, H.G., Johannsen, V.K., Nord-Larsen, T., Vesterdal, L., Stupak, I., Scott-Bentsen, N., Rasmussen, E., Petersen, S.B., Olsen, T.M. & Hansen, M.G. 2021. Denmark's National Inventory Report 2021. Emission Inventories 1990-2019 - Submitted under the United Nations Framework Convention on Climate Change and the Kyoto Protocol. 944 pp. - Scientific Report from DCE - Danish Center for Environment and Energy no. 437. Available at: <https://dce2.au.dk/pub/SR437.pdf>

Shires et al., 2004: Theresa M. Shires and Christopher J. Loughran. American Petroleum Institute (API), Compendium of Greenhouse Gas Emissions Methodologies for the Oil and Gas Industry, February 2004. Available at: <http://www.scribd.com/doc/73896273/2004-COMPENDIUM-of-Greenhouse-Gas-Emissions-Estimates> (8/12-2020).

Shires, T.M., Loughran, C.J., Jones, S. Hopkins, E., 2009: Theresa M. Shires, Christopher J. Loughran, Stephanie Jones and Emily Hopkins. American Petroleum Institute (API), Compendium of Greenhouse Gas Emissions Methodologies for the Oil and Gas Industry, August 2009. Available at: [Compendium of GHG Emissions Methodologies for Oil and Natural Gas Industry \(ca.gov\)](https://www.eia.doe.gov/totalinfo/compendium_of_ghg_emissions_methodologies_for_oil_and_natural_gas_industry) (23/3-2022).

US EPA, 2004: Technology Transfer Network Clearinghouse for Inventories & Emissions Factors. AP 42, Fifth Edition, Volume I, Chapter 11: Mineral Products Industry Available at: <https://www3.epa.gov/ttnchie1/ap42/ch11/> (8/12-2020).

16.5 Agriculture (CRF sector 3)

The emission of greenhouse gases from agricultural activities includes CH₄ emission from enteric fermentation, CH₄ and N₂O emission from manure management and N₂O emission from agricultural soils. The emissions are reported in CRF Tables 3.A, 3.B, 3.D and 3.G.

Emission from rice production, burning of agricultural crop residue and burning of savannas does not occur in Greenland and the CRF Tables 3.C, 3.E and 3.F have, consequently, not been completed.

Emission of non-methane volatile organic compounds (NMVOC) from agricultural activities has not been estimated.

16.5.1 Overview of sector

In CO₂ equivalents, the agricultural sector (without LULUCF) contributes with 1.5 % of the overall greenhouse gas emission (GHG) in 2020. From 1990 to 2020 emissions have decreased from 9.54 Gg CO₂ equivalents to 8.91 Gg CO₂ equivalents, which correspond to a decrease of 6.6 %, see Table 16.5.1. This emission decrease is primarily caused by a decrease in the number of reindeers.

Table 16.5.1 Emission of GHG in the agricultural sector 1990-2020 in Gg CO₂ equivalents.

	1990	1991	1992	1993	1994	1995	1996	1997	1998	1999	2000
CH ₄	7.81	7.88	7.08	6.21	6.78	7.29	7.50	8.20	7.81	7.08	6.88
N ₂ O	1.73	1.74	1.57	1.42	1.54	1.64	2.26	2.01	2.49	2.57	2.29
Total	9.54	9.62	8.65	7.63	8.32	8.92	9.76	10.21	10.30	9.65	9.17
<i>continued</i>	2001	2002	2003	2004	2005	2006	2007	2008	2009	2010	2011
CH ₄	6.99	6.72	6.81	7.16	7.45	7.22	7.39	7.21	7.06	7.24	7.08
N ₂ O	2.36	2.22	2.26	2.40	2.52	2.53	2.23	3.28	2.43	2.40	2.61
Total	9.35	8.94	9.07	9.56	9.97	9.75	9.62	10.49	9.49	9.63	9.70
<i>continued</i>	2012	2013	2014	2015	2016	2017	2018	2019	2020		
CH ₄	7.05	7.01	6.62	6.24	6.45	6.33	6.46	6.33	6.43		
N ₂ O	2.48	2.44	2.56	2.34	2.31	1.83	1.61	2.35	2.48		
Total	9.52	9.45	9.18	8.58	8.76	8.16	8.07	8.68	8.91		

As showed in Figure 16.5.1, CH₄ emission contributed with 72% of the total GHG emission from the agricultural sector in 2020. N₂O contributed with 28 %. The major part of the emission is related to livestock production, which in Greenland particularly means the production of sheep. A smaller part is related to the reindeer production. Concerning the emission from agricultural soils, the main sources are use of inorganic fertiliser, nitrogen leaching from leaching and run-off and emission from grassing animals.

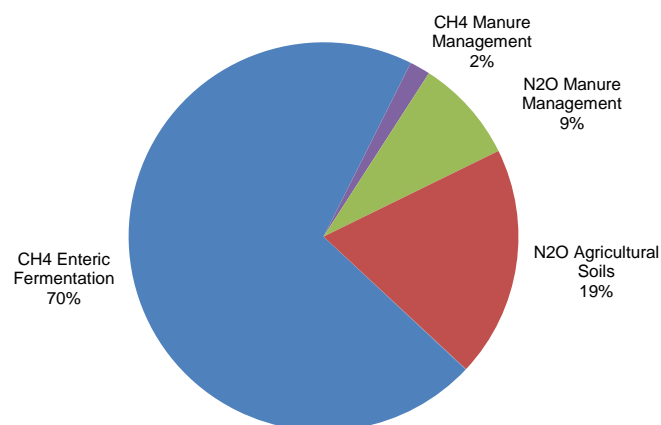

Figure 16.5.1 Emission of greenhouse gases from agriculture in 2020.

16.5.2 Source category description

The calculations of the emissions are based on methods described in the IPCC Reference Manual (IPCC, 2006) and the Good Practice Guidance (IPCC, 2000).

Statistics Greenland is responsible for collecting of data, preparation of emission inventory and reporting. Inputs of data are basically obtained from Statistics Greenland and the Greenland Agricultural Consulting Services (ACS). Data on climate are supplied by the Danish Meteorological Institute (DMI) and Greenland Survey (ASIAQ), and published by Statistics Greenland.

Table 16.5.2 List of institutes involved in the emission inventory for the agricultural sector.

References	Link	Abbreviation	Data/information
Statistics Greenland	www.stat.gl	GS	- reporting - data collecting - no. of animal - feed import - use of inorganic fertiliser - spring temperature
The Agricultural Consulting Services	http://nunalerineq.org	ACS	- N-excretion - milk yield - feed consumption and composition - stable- and grassing situation - animal growth and weight - land use - crop production
The Danish Plant Directorate	www.pdir.dk	PD	- N content in different fertiliser types
The Danish Agricultural Advisory Centre, Aarhus University	www.lr.dk	DAAC	- N content in crop residue - CO ₂ from liming

16.5.3 CH₄ emission from Enteric Fermentation (CRF sector 3A)

Description

The majority part of the agricultural CH₄ emission originates from digestive processes. In 2020 this source accounts for 70.4 % of the total GHG emission from agricultural activities. The emission is primarily related to ruminants, which in Greenland is sheep. In 2020 sheep contributed with 87.2 % and the remaining 12.8 % from reindeer.

Methodological issues

The implied emission factors for all animal categories are based on the Tier 2/Country Specific (CS) approach. Feed consumption and composition for

sheep and reindeer is based on data from Statistics Greenland and the Agricultural Consulting Services (ACS), which has information concerning the agricultural conditions in practice. Default values for the methane conversion rate (Y_m) for sheep given by the IPCC are used, as an average of mature sheep and lambs, which mean an Y_m value of 6.5 % for sheep and 6.0 % for reindeer.

Gross energy intake (GE)

The gross energy intake for sheep and reindeer is based on feeding plans for sheep from the Greenland Agricultural Consulting Services supplemented by data on imported feed. For reindeer information on gross energy intake is based on an article on reindeer management in Greenland.

Table 16.5.3 Parameters for calculation of emission from enteric fermentation.

Animal Category	Gross Energy (GE) MJ pr head pr day	Methane conversion factor (Y_m)	Emission factor Kg CH ₄ pr head pr yr
Sheep	28.4	0.065	12.1
Reindeer	27.2	0.060	10.7

The default CH₄ emission factor for sheep Tier 1 methodology is estimated to 8 kg CH₄ per animal per year for developed countries. The default GE is given as 20 MJ/head/yr, which is lower than the calculated GE for Greenland, and can explain the lower emission factor. Another reason could be the fact that the national value for feed intake includes lambs. After lambing, ewes and lambs are put out to pasture. Thus lambs only feed through their mother and grass. Lambs are not fed separately before slaughter.

There is no default GE for reindeer. However, Norway, Sweden and Finland have estimated gross energy intake for reindeer to 29.6 - 31.6 MJ/head/day. Based on an article on reindeer management in southern Greenland by H.E. Rasmussen in 1992, the Greenlandic gross energy intake for reindeer has been estimated to 27.2 MJ pr head pr day, which is lower than Norway, Sweden and Finland. However, holding in mind that food conditions for reindeer is more scarcely in Greenland compared to conditions in Norway, Sweden and Finland, which have more forest, and that reindeer in Greenland are not fed separately, the estimated of gross energy intake for reindeer in Greenland seems acceptable.

Activity data

Table 16.5.4 shows the development in livestock. The number of sheep is varying slightly. The number of reindeer has decreased considerably since 1990. The reindeer livestock decreased significantly in 1999, when one of two reindeer stations closed. Since 1999 there has been only one reindeer station in Greenland.

Table 16.5.4 Number of animals from 1990-2020 (CRF Table 3.A. 3.B (a) and 3.B (b)).

	1990	1991	1992	1993	1994	1995	1996	1997	1998	1999	2000
Sheep	19 929	20 134	17 900	16 256	17 818	19 464	20 163	23 134	19 929	21 007	20 444
Reindeer	6 000	6 000	5 600	4 300	4 600	4 600	4 600	3 800	6 000	2 106	2 000
<i>continued</i>	2001	2002	2003	2004	2005	2006	2007	2008	2009	2010	2011
Sheep	20 394	18 967	19 259	20 383	21 317	21 289	21 704	21 080	20 139	20 729	20 232
Reindeer	2 480	3 100	3 100	3 100	3 100	2 318	2 441	2 500	3 000	3 000	3 000
<i>continued</i>	2012	2013	2014	2015	2016	2017	2018	2019	2020		
Sheep	20 107	19 994	18 738	17 501	18 190	17 785	18 212	17 785	18 105		
Reindeer	3 000	3 000	3 000	3 000	3 000	3 000	3 000	3 000	3 000		

Implied emission factor

The implied emission factor (IEF) could vary across years for sheep and reindeer due to changes in feed consumption. However, no existing data can document a change in feed intake. Therefore the same IEF is used for all years.

Time series consistency

The emission from enteric fermentation is given in Table 16.5.5. From 1990 to 2020, the emission has decreased by 17.7 % specifically due to a fall in number of both reindeer and sheep.

Table 16.5.5 Emission of CH₄ from Enteric Fermentation 1990-2020, tonnes CH₄.

CRF 3.A	1990	1991	1992	1993	1994	1995	1996	1997	1998	1999	2000
Sheep	241	243	216	197	215	235	244	280	241	254	247
Reindeer	64	64	60	46	49	49	49	41	64	23	21
Total, tonnes CH ₄	305	308	276	243	265	284	293	320	305	276	269
Total, tonnes CO ₂ eqv.	7 627	7 689	6 907	6 063	6 615	7 112	7 324	8 008	7 627	6 912	6 714
<i>continued</i>	2001	2002	2003	2004	2005	2006	2007	2008	2009	2010	2011
Sheep	247	229	233	246	258	257	262	255	243	251	245
Reindeer	27	33	33	33	33	25	26	27	32	32	32
Total, tonnes CH ₄	273	262	266	280	291	282	288	282	276	283	277
Total, tonnes CO ₂ eqv.	6 827	6 561	6 650	6 989	7 272	7 054	7 212	7 040	6 889	7 067	6 917
<i>continued</i>	2012	2013	2014	2015	2016	2017	2018	2019	2020		
Sheep	243	242	227	212	220	215	220	215	219		
Reindeer	32	32	32	32	32	32	32	32	32		
Total, tonnes CH ₄	275	274	259	244	252	247	252	247	251		
Total, tonnes CO ₂ eqv.	6 879	6 845	6 465	6 091	6 300	6 177	6 306	6 177	6 274		

16.5.4 CH₄ and N₂O emission from Manure Management (CRF sector 3B)**Description**

The emissions of CH₄ and N₂O from manure management are given in CRF Table 3.B (a) and 3.B (b). This source contributes with 10.3 % of the total emission from the agricultural sector in 2020. The major part of the emission originates from the production of sheep.

Methodological issues**CH₄ emission**

The IPCC 2006 Tier 2/CS methodology has been used for the estimation of the CH₄ emission from manure management. Calculation of volatile solid excretion rates, VS is based on national value of gross energy intake (GE). The VS excretion rate is estimated as:

$$VS = \left[GE \times \left(1 - \frac{DE\%}{100} \right) + (UE \times GE) \right] \times \left[\left(\frac{1 - ASH}{18.45} \right) \right]$$

Where default values are used for digestibility (DE), the fraction of urinary energy excretion (UE) and the ash content (ASH), see Table 16.5.6.

In the calculation of the CH₄ emission factor from manure management default values are used for maximum methane producing capacity (B₀) and the methane conversion factor (MCF), see Table 16.5.6.

For reindeer no default values exists. Thus DE, ASH and B₀ estimates for sheep are used. Sheep and reindeer are similar creatures, both ruminants. Greenlandic reindeer weigh an average of 70 kg. Greenlandic sheep weight approximately 50 kg. However, while sheep are fed relative more intensively, reindeer only feed on what they find in nature all year around. On these arguments the best estimate is to use DE, ASH and B₀ estimates for sheep on reindeer as well.

Table 16.5.6 CH₄ – Manure management – use of national parameters and IPCC default values.

Parameter	Unit	Sheep	Reindeer	Default or national value
Gross energy intake (GE)	MJ pr head pr day	28.4	27.2	National
Digestibility (DE)	Percent	60	60	IPCC default
Urinary energy excretion (UE)	Percent	4	4	IPCC default
Ash content (ASH)	Percent	8	8	IPCC default
Volatile solids (VS)	Kg VS pr head pr day	0.62	0.60	National
Max. methane producing capacity (B ₀)	M ³ pr kg VS	0.19	0.19	IPCC default
CH ₄ conversion factor (MCF), dry lot	Percent	1	1	IPCC default
CH ₄ conversion factor (MCF), pasture, range and paddock	Percent	1	1	IPCC default
Emission factor	Kg CH ₄ pr head pr yr	0.29	0.28	Tier 2

There are no changes in stable conditions or feed intake during the years 1990 to 2020. The implied emission factor is therefore the same for all years.

The default emission factor for sheep in cool areas is 0.19 kg CH₄ per head per year. The higher national value is due to a higher estimate for gross energy intake that accounts for both sheep and lamb.

Table 16.5.7 shows a decrease in the CH₄ emission from manure management from 1990 to 2020 by 18.4 % related to the fall in the number of both reindeer and sheep.

Table 16.5.7 Emission of CH₄ from Manure Management 1990-2020, tonnes CH₄.

CRF 3.A	1990	1991	1992	1993	1994	1995	1996	1997	1998	1999	2000
Sheep	5.8	5.8	5.2	4.7	5.2	5.6	5.8	6.7	5.8	6.1	5.9
Reindeer	1.7	1.7	1.6	1.2	1.3	1.3	1.3	1.1	1.7	0.6	0.6
Total, tonnes CH ₄	7.5	7.5	6.8	5.9	6.5	6.9	7.1	7.8	7.5	6.7	6.5
<i>continued</i>	2001	2002	2003	2004	2005	2006	2007	2008	2009	2010	2011
Sheep	5.9	5.5	5.6	5.9	6.2	6.2	6.3	6.1	5.8	6.0	5.9
Reindeer	0.7	0.9	0.9	0.9	0.9	0.6	0.7	0.7	0.8	0.8	0.8
Total, tonnes CH ₄	6.6	6.4	6.5	6.8	7.0	6.8	7.0	6.8	6.7	6.9	6.7
<i>continued</i>	2012	2013	2014	2015	2016	2017	2018	2019	2020		
Sheep	5.8	5.8	5.4	5.1	5.3	5.2	5.3	5.2	5.3		
Reindeer	0.8	0.8	0.8	0.8	0.8	0.8	0.8	0.8	0.8		
Total, tonnes CH ₄	6.7	6.6	6.3	5.9	6.1	6.0	6.1	6.0	6.1		

N₂O emission

Based on information from the Greenland Agricultural Consulting Services it is estimated that for sheep 55 % of the N-excretion is taken place in stable (dry lot) and all manure is handled as solid manure. The IPCC default emission value is applied, which means 2.0 % of the N-excretion for solid manure. Sheep is grassing 45 % of the year. The emission from manure deposits on grass is included in "Pasture, Range and Paddock".

Reindeer is grassing all year. The emission from manure deposits on grass is included in "Pasture, Range and Paddock".

The total nitrogen excretion for sheep has decreased by 18.3 % from 1990 to 2020 (Table 16.5.8) due to a drop in the number of livestock.

Table 16.5.8 Total nitrogen excretion for sheep, 1990-2020, tonnes N.

CRF table 3.B(b)	1990	1991	1992	1993	1994	1995	1996	1997	1998	1999	2000
N-excreted, tonnes in total	154	155	140	122	133	143	147	161	154	138	134
N-excretion, tonnes in stable	66	66	59	54	59	64	67	76	66	69	67
<i>continued</i>	2001	2002	2003	2004	2005	2006	2007	2008	2009	2010	2011
N-excreted, tonnes in total	137	132	133	140	146	141	144	141	138	142	139
N-excretion, tonnes in stable	67	63	64	67	70	70	72	70	66	68	67
<i>continued</i>	2012	2013	2014	2015	2016	2017	2018	2019	2020		
N-excreted, tonnes in total	138	137	130	122	126	124	127	124	126		
N-excretion, tonnes in stable	66	66	62	58	60	59	60	59	60		

Time series consistency

As shown in Table 16.5.9 total emission from manure management has decreased by 12.6 % from 1990 to 2020 due to a decrease in the number of sheep and reindeer.

Table 16.5.9 Emissions of N₂O and CH₄ from Manure Management 1990-2020.

	1990	1991	1992	1993	1994	1995	1996	1997	1998	1999	2000
N ₂ O emission, tonnes CO ₂ eqv.	869	877	782	704	771	839	867	983	869	882	858
CH ₄ emission, tonnes CO ₂ eqv.	186	188	169	148	161	173	178	194	186	167	162
Total, tonnes CO ₂ eqv.	1 055	1 065	951	852	932	1 012	1 046	1 178	1 055	1 049	1 020
<i>continued</i>	2001	2002	2003	2004	2005	2006	2007	2008	2009	2010	2011
N ₂ O emission, tonnes CO ₂ eqv.	860	806	818	864	903	896	914	888	854	878	857
CH ₄ emission, tonnes CO ₂ eqv.	165	159	161	169	176	171	174	170	167	171	168
Total, tonnes CO ₂ eqv.	1 025	965	980	1 034	1 079	1 066	1 088	1 059	1 021	1 049	1 025
<i>continued</i>	2012	2013	2014	2015	2016	2017	2018	2019	2020		
N ₂ O emission, tonnes CO ₂ eqv.	852	848	796	745	773	757	774	757	770		
CH ₄ emission, tonnes CO ₂ eqv.	167	166	157	148	153	150	153	150	152		
Total, tonnes CO ₂ eqv.	1 019	1 014	953	893	926	907	927	907	922		

16.5.5 N₂O emission from Agricultural Soils (CRF sector 3D)

Description

N₂O emissions from agricultural soils contributed with 20.0 % of total emissions from the agricultural sector in 2020. Figure 16.5.2 shows the overall development from 1990 to 2020 and the distribution on different sources. Since 1990 N₂O emissions increased suddenly in 1996, when farmers increased their use of inorganic fertiliser significantly. From 1997 to 2007 the emission of N₂O varied with an increasing trend. In 2008 the emission of N₂O increased considerably due to a considerable increase in the use of inorganic fertiliser caused by a periodical drought in the agricultural part of Greenland. In 2009 the use of inorganic fertiliser returned back to a more normal level, thus the emission of N₂O dropped as well. In 2017 and 2018 N₂O emissions decreased quite abrupt due to a sudden drop in the use of inorganic fertilisers. In 2019 and 2020 emission from the use on inorganic fertilisers has returned to the usual level, returning overall N₂O emission to its usual level as well.

Emission from inorganic fertiliser and nitrogen leaching is an essential part of the total emission from agricultural soils and contributes totally with 55.6 % of total in 2020. Of the remaining sources the greatest part of the emission, by 16.8 %, origins from urine and dung deposited by grazing animals. Emissions from all sources have increased or remained the same from 1990 to 2020 except from animal manure applied to soils and urine and dung deposited by grazing animals both due to a fall in number of reindeer and sheep.

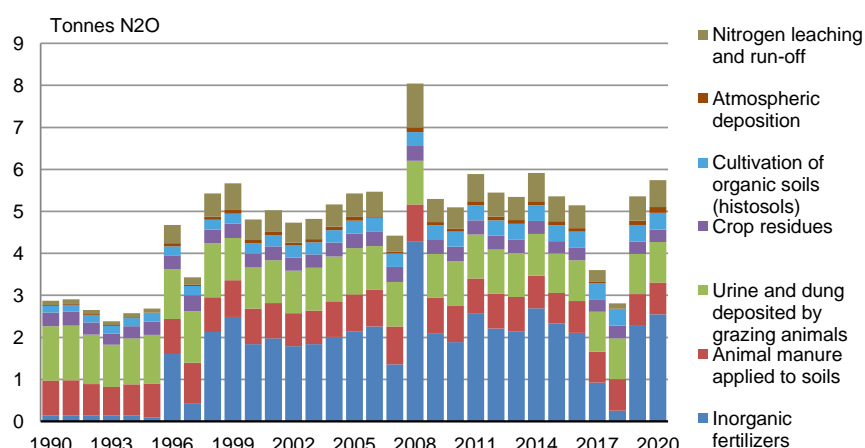
Figure 16.5.2 N₂O emissions from agricultural soils 1990-2020.

Methodological issues

To calculate the N₂O emission a combination of IPCC Tier 1a and Tier 1b is used. Tier 1b is used in calculation of emission from crop residues. Emissions of N₂O are closely related to the nitrogen balance. Data concerning the N-excretion, evaporation of ammonia from inorganic fertiliser and grassing animal are based on national values.

The NH₃ and N₂O emission factor survey is presented in Table 16.5.10 and shows that except from histosols all N₂O emission factor is based on IPCC default values. The estimated emissions from the different sub-sources are described in the text which follows.

Table 16.5.10 Emissions factor - N₂O emission from Agricultural Soils 1990-2020.

Agricultural soils – emission sources CRF Table 3.D	Ammonia emission factor Kg NH ₃ -N pr kg N	N ₂ O emission factor (country specific value) kg N ₂ O-N pr ha	N ₂ O emission factor (IPCC default value) kg N ₂ O -N pr kg N
a. Direct N ₂ O emissions from managed soils			
1. Inorganic N fertilisers	0.06 (CS)		0.01
2. Organic N fertilisers			
Animal manure applied to soils	0.20 (IPCC default)		0.01
3. Urine and dung deposited by grazin animals			0.01
4. Crop residues			0.01
Cultivation of organic soils (i.e. histosols)		0.86*	
b. Indirect N ₂ O emissions from managed soils			
Atmospheric deposition			0.01
Nitrogen leaching and run-off			0.0075

CS = country specific value. FracGASF, depending upon the annual mix of inorganic fertilisers.

* Include both emission from cropland and improved grassland. For further details see Section 16.6.

Direct emissions

Inorganic fertiliser

The calculation of nitrogen (N) applied to soils from use of inorganic fertiliser is based on data on imports from the Statistics Greenland. No data is available before 1994. The consumption for 1990 to 1993 is assumed to be on the same level as 1994. The nitrogen content for each fertiliser type is estimated based on expert judgement from the Danish Plant Directorate (Troels Knudsen, pers. comm.).

Table 16.5.11 shows the consumption of each type of fertiliser in 2020. Furthermore, the ammonia emission factor for each fertiliser is given, based on the values given in EMEP/EEA emission inventory guide book 2019 (Table 3-2). The emission factors are depending on a normal pH of 7.0 or below, and a cool climate with mean spring temperature estimated to seven degrees in Greenland. The spring temperature has to reflect the time where the fertilisers are applied, which in Greenland normally is June.

Table 16.5.11 Consumption of inorganic fertiliser 2020 and the NH₃ emission factors.

Inorganic fertiliser	NH ₃ Emission factor ¹ kg NH ₃ per kg N applied	Consumption ² t N
Type of fertiliser		
Ammonium sulphate	0.090	NO
Ammonium nitrate	0.015	0.0
Calcium ammonium nitrate	0.008	0.0
Anhydrous ammonia	0.019	NO
Urea	0.155	26.8
Nitrogen solutions	0.098	NO
Ammonium phosphates	0.050	NO
Other NK and NPK	0.050	135.6
Total consumption of N in inorganic fertiliser		162.4
National emission of NH ₃ , tonnes	10.933	
National emission of NH ₃ -N, tonnes	9.004	
Average NH ₃ -N emission (Frac _{GASF}) ³	0.055	

¹) EMEP/EEA (2019), cool climate and pH-value of 7.0 or below.

²) Statistics Greenland and the Danish Plant Directorate.

³) Frac_{GASF} fraction of synthetic fertiliser N that volatilises as NH₃.

The Greenlandic value for the Frac_{GASF} is estimated to 0.06 in 2020, which is considerably lower than the recommended default value 0.10 (IPCC 2006, Table 11.3). The majority part of the fertiliser types used in Greenland is related to NPK fertiliser where the emission factor is relative low, i.e. 5.0 kg NH₃-N pr kg N. Before 1995 urea accounted for a higher fraction. The value of Frac_{GASF} for these years is estimated to 0.127.

Table 16.5.12 Frac_{GASF}, 1990-2020.

	1990	1991	1992	1993	1994	1995	1996	1997	1998	1999	2000
Frac _{GASF}	0.127	0.127	0.127	0.127	0.127	0.106	0.047	0.055	0.036	0.034	0.041
<i>continued</i>	2001	2002	2003	2004	2005	2006	2007	2008	2009	2010	2011
Frac _{GASF}	0.041	0.041	0.041	0.041	0.040	0.016	0.026	0.025	0.039	0.041	0.036
<i>continued</i>	2012	2013	2014	2015	2016	2017	2018	2019	2020		
Frac _{GASF}	0.040	0.041	0.034	0.043	0.040	0.040	0.049	0.044	0.055		

Table 16.5.13 shows a general increase in use of fertiliser and a particular jump upwards in 1996 and 2008. Due to a relatively small number of farms the individual handling of one farmer has a high effect on the total consumptions. With consumption of fertilisers being based on imports of fertilisers it is not possible to account for fertilisers bought for stockpiling. Thus it is possible that the relative high increase in use of fertilisers in 2008 is due to stockpiling. Another explanation could be that both 2007 and 2008 were relative dry years leading to a considerable decrease in amount of hay harvested.

Table 16.5.13 Nitrogen applied as fertiliser to agricultural soils 1990-2020.

	1990	1991	1992	1993	1994	1995	1996	1997	1998	1999
N content in inorganic fertiliser, tonnes N	9	9	9	9	9	6	102	28	135	158
NH ₃ -N emission, tonnes	1	1	1	1	1	1	5	2	5	5
N in fertiliser applied on soil, tonnes N	8	8	8	8	8	5	97	26	130	153
N ₂ O emission, tonnes	0.15	0.15	0.15	0.15	0.15	0.10	1.60	0.43	2.13	2.49
<i>continued</i>	2000	2001	2002	2003	2004	2005	2006	2007	2008	2009
N content in inorganic fertiliser, tonnes N	117	126	114	117	128	136	144	86	273	134
NH ₃ -N emission, tonnes	5	5	5	5	5	5	2	2	7	5
N in fertiliser applied on soil, tonnes N	112	120	109	112	123	131	141	84	266	129
N ₂ O emission, tonnes	1.84	1.97	1.79	1.84	2.01	2.14	2.26	1.36	4.29	2.10
<i>continued</i>	2010	2011	2012	2013	2014	2015	2016	2017	2018	2019
N content in inorganic fertiliser, tonnes N	120	163	141	136	172	148	134	59	16	146
NH ₃ -N emission, tonnes	5	6	6	6	6	6	5	2	1	6
N in fertiliser applied on soil, tonnes N	115	157	135	130	166	142	129	56	15	140
N ₂ O emission, tonnes	1.89	2.56	2.21	2.13	2.70	2.33	2.11	0.92	0.25	2.30
<i>continued</i>	2020									
N content in inorganic fertiliser, tonnes N	162									
NH ₃ -N emission, tonnes	9									
N in fertiliser applied on soil, tonnes N	153									
N ₂ O emission, tonnes	2.55									

Manure applied to soil

The amount of nitrogen applied to soils from sheep on stables is estimated as the N-excretion in stables minus the ammonia emission, which occur in stables, under storage and in relation to the application of manure. There are no measurements of ammonia emission from stables in Greenland. Thus IPCC default is used. The FracGASM default at 0.20 (IPCC 2006, Table 11-3) match the Danish emission ammonia from sheep and lamb together, which are estimated to 18 % in 2020. A lower ammonia emission in Greenland is expected due to the cold climate, but on the other hand no ammonia reducing measures are implemented as in Denmark. The FracGASM at 0.20 are therefore considered as reliable.

Table 16.5.14 shows the development in nitrogen excretion in stables, the estimated amount of N applied on soil and the N₂O emission.

Table 16.5.14 Nitrogen applied as manure to agricultural soils 1990-2020.

	1990	1991	1992	1993	1994	1995	1996	1997	1998	1999
N-excretion in stable, tonnes N	66	66	59	54	59	64	67	76	66	69
NH ₃ -N emission, tonnes N	13	13	12	11	12	13	13	15	13	14
N in manure applied on soil, tonnes N	53	53	47	43	47	51	53	61	53	55
N ₂ O emission, tonnes N ₂ O	0.83	0.84	0.74	0.67	0.74	0.81	0.84	0.96	0.83	0.87
<i>continued</i>	2000	2001	2002	2003	2004	2005	2006	2007	2008	2009
N-excretion in stable, tonnes N	67	67	63	64	67	70	70	72	70	66
NH ₃ -N emission, tonnes N	13	13	13	13	13	14	14	14	14	13
N in manure applied on soil, tonnes N	54	54	50	51	54	56	56	57	56	53
N ₂ O emission, tonnes N ₂ O	0.85	0.85	0.79	0.80	0.85	0.88	0.88	0.90	0.87	0.84
<i>continued</i>	2010	2011	2012	2013	2014	2015	2016	2017	2018	2019
N-excretion in stable, tonnes N	68	67	66	66	62	58	60	59	60	59
NH ₃ -N emission, tonnes N	14	13	13	13	12	12	12	12	12	12
N in manure applied on soil, tonnes N	55	53	53	53	49	46	48	47	48	47
N ₂ O emission, tonnes N ₂ O	0.86	0.84	0.83	0.83	0.78	0.73	0.75	0.74	0.76	0.74
<i>continued</i>	2020									
N-excretion in stable, tonnes N	60									
NH ₃ -N emission, tonnes N	12									
N in manure applied on soil, tonnes N	48									
N ₂ O emission, tonnes N ₂ O	0.75									

Crop residue

The cultivated area is approximately 1,177 ha with the main part as grass fields. Only 10.5 ha are used for potato production. The cultivated area has increased slightly over the years.

The emission from crop residues is estimated based on the tier 1 methodology in the 2006 IPCC Guidelines. Default values for all parameters given in IPCC 2006 Table 11.2 are used.

N₂O emissions from crop residues are calculated based on the total above- and belowground Nitrogen content (N-content) in crop residue returned to soil, which in Greenland includes residue of leaves and roots from grass fields and the top and root from potatoes. Harvest of potatoes and grass-clover are calculated based on relatively few observations related to Danish conditions, but are at present the best available data.

In this 2022-submission the calculation of belowground N-content has been revised. In prior submissions calculation of belowground N-content was based only on the dry matter fraction (DRY) of the harvested crop. However, Danish studies have shown that the above-ground residue dry matter (AGDM) should be included in the calculation of belowground N-content. The revised calculation of belowground N-content in crop residue has led to a higher amount of dry matter and therefore to a higher estimate of N-content in the belowground crop residue.

Table 16.5.15 N-content in crop residues 2020.

Crop type	Husks	Stubble	Top	Leafs	Frequency of ploughing	Nitrogen content in crop residue	
	kg N pr ha				No. of years between ploughing	kg N pr ha	kg N
Potatoes	7.8	-	4.8	-	1	12.7	133
Grass-Clover mixtures in rotation	-	11.2	-	5.0	5	16.2	18 881
Total N from crop residue, kg						19 014	

Reference: National data and IPCC 2006 (Table 11.2).

To calculate the N₂O emission the IPCC standard emission factor 1.0 % is used. The national emission from crop residues has been relatively stable from 1990 to 2020 (Table 16.5.16).

Table 16.5.16 Emission from crop residues 1990-2020.

Crop residue	1990	1991	1992	1993	1994	1995	1996	1997	1998	1999
Potatoes, kg N	-	-	-	-	-	-	-	-	-	-
Grass-Clover, kg N	20 783	20 997	18 667	16 953	18 581	20 298	21 027	24 125	20 783	21 907
Crop residue total, kg N	20 783	20 997	18 667	16 953	18 581	20 298	21 027	24 125	20 783	21 907
N ₂ O emission, kg	327	330	293	266	292	319	330	379	327	344
<i>continued</i>	2000	2001	2004	2005	2006	2007	2008	2009	2010	2011
Potatoes, kg N	-	63	63	63	63	63	63	63	63	82
Grass-Clover, kg N	21 320	21 268	19 780	20 084	21 256	22 230	22 201	22 634	21 983	21 002
Crop residue total, kg N	21 320	21 331	19 843	20 148	21 320	22 294	22 265	22 697	22 047	21 084
N ₂ O emission, kg	335	335	312	317	335	350	350	357	346	331
<i>continued</i>	2010	2011	2012	2013	2014	2015	2016	2017	2018	2019
Potatoes, kg N	82	133	133	133	133	133	133	133	133	133
Grass-Clover, kg N	21 617	21 099	20 969	20 851	19 541	18 251	18 969	18 547	18 992	18 547
Crop residue total, kg N	21 700	21 232	21 102	20 984	19 674	18 384	19 102	18 680	19 125	18 680
N ₂ O emission, kg	341	334	332	330	309	289	300	294	301	294
<i>continued</i>	2020									
Potatoes, kg N	133									
Grass-Clover, kg N	18 881									
Crop residue total, kg N	19 014									
N ₂ O emission, kg	299									

Cultivation of histosols

N₂O emissions from histosols are based on the area with organic soils multiplied by the emission factor of 0.86 kg N₂O-N pr. hectare in 2020. See Section 16.6 on LULUCF for further description on cultivation of histosols.

Table 16.5.17 shows an increase in the N₂O emission from 1990 to 2020 due an increase in the agricultural area.

Table 16.5.17 Activity data and emission from cultivation of histosols 1990-2020.

CRF – Table 3.D	1990	1991	1992	1993	1994	1995	1996	1997	1998	1999
Cultivated histosols, ha	123	129	136	142	149	155	161	168	174	181
N ₂ O emission, kg	160	169	177	186	194	203	211	220	228	237
<i>continued</i>	2000	2001	2002	2003	2004	2005	2006	2007	2008	2009
Cultivated histosols, ha	187	195	214	220	223	232	242	247	252	262
N ₂ O emission, kg	245	260	285	293	297	308	321	328	335	350
<i>continued</i>	2010	2011	2012	2013	2014	2015	2016	2017	2018	2019
Cultivated histosols, ha	268	270	273	275	277	282	285	287	291	293
N ₂ O emission, kg	357	364	367	370	373	379	383	386	391	394
<i>continued</i>	2020									
Cultivated histosols, ha	294									
N ₂ O emission, kg	396									

Pasture, Range and Paddock

The amount of nitrogen deposited on grass includes grassing from reindeer 365 days a year and from sheep 164 days a year. An ammonia emission factor of 7 % is used for all animal categories based on investigations from the Netherlands and the United Kingdom (Jarvis et al., 1989a, Jarvis et al., 1989b and Bussink, 1994). EMEP/EEA Emission Inventory Guidebook 2019 use a similar emission factor at 9 % for sheep (Table 3.9).

Table 16.5.18 shows the estimated values of N-excretion from grassing animals, ammonia emission and N₂O emission. As a consequence of an overall drop in number of reindeer and recently also sheeps N₂O emission has decreased from 1990 to 2020.

Table 16.5.18 Emission from grassing animals 1990-2020.

	1990	1991	1992	1993	1994	1995	1996	1997	1998	1999
N-excretion on grass, tonnes N	88	89	81	69	75	79	81	84	88	69
NH ₃ -N emission, tonnes	6	6	6	5	5	6	6	6	6	5
N deposited on grass, tonnes N	82	83	75	64	69	73	75	78	82	64
N ₂ O emission, tonnes	1.29	1.30	1.18	1.00	1.09	1.15	1.18	1.23	1.29	1.01
<i>continued</i>	2000	2001	2002	2003	2004	2005	2006	2007	2008	2009
N-excretion on grass, tonnes N	67	69	69	70	73	75	71	73	71	72
NH ₃ -N emission, tonnes	5	5	5	5	5	5	5	5	5	5
N deposited on grass, tonnes N	62	64	64	65	68	70	66	68	66	67
N ₂ O emission, tonnes	0.97	1.01	1.01	1.02	1.06	1.10	1.03	1.06	1.04	1.05
<i>continued</i>	2010	2011	2012	2013	2014	2015	2016	2017	2018	2019
N-excretion on grass, tonnes N	73	72	72	71	68	65	66	65	66	65
NH ₃ -N emission, tonnes	5	5	5	5	5	5	5	5	5	5
N deposited on grass, tonnes N	68	67	67	66	63	60	62	61	62	61
N ₂ O emission, tonnes	1.07	1.05	1.05	1.04	0.99	0.94	0.97	0.95	0.97	0.95
<i>continued</i>	2020									
N-excretion on grass, tonnes N	66									
NH ₃ -N emission, tonnes	5									
N deposited on grass, tonnes N	62									
N ₂ O emission, tonnes	0.97									

Indirect emissions

Atmospheric deposition

Atmospheric deposition includes ammonia emission from manure management, use of inorganic fertiliser and from grassing animals.

N₂O emission from atmospheric deposition has more than doubled from since 1990. Even though the number of reindeer and sheep has decreased, the increasing use of inorganic fertiliser has increased total N₂O emission from atmospheric deposition by 665.4 % from 1990 to 2020.

Table 16.5.19 Emission from atmospheric deposition 1990-2020.

	1990	1991	1992	1993	1994	1995	1996	1997	1998	1999
NH ₃ -N manure management, tonnes	13	13	12	11	12	13	13	15	13	14
NH ₃ -N inorganic fertilizer, tonnes	1	1	1	1	1	1	5	2	5	5
NH ₃ -N pasture, tonnes	6	6	6	5	5	6	6	6	6	5
NH ₃ -N total, tonnes	21	21	19	17	18	19	24	23	24	24
N ₂ O emission, tonnes	0.02	0.02	0.02	0.02	0.02	0.01	0.08	0.02	0.08	0.09
<i>continued</i>	2000	2001	2002	2003	2004	2005	2006	2007	2008	2009
NH ₃ -N manure management, tonnes	13	13	13	13	13	14	14	14	14	13
NH ₃ -N inorganic fertilizer, tonnes	5	5	5	5	5	5	2	2	7	5
NH ₃ -N pasture, tonnes	5	5	5	5	5	5	5	5	5	5
NH ₃ -N total, tonnes	23	23	22	22	24	25	21	22	26	24
N ₂ O emission, tonnes	0.08	0.08	0.07	0.08	0.08	0.09	0.04	0.04	0.11	0.08
<i>continued</i>	2010	2011	2012	2013	2014	2015	2016	2017	2018	2019
NH ₃ -N manure management, tonnes	14	13	13	13	12	12	12	12	12	12
NH ₃ -N inorganic fertilizer, tonnes	5	6	6	6	6	6	5	2	1	6
NH ₃ -N pasture, tonnes	5	5	5	5	5	5	5	5	5	5
NH ₃ -N total, tonnes	24	24	24	24	23	22	22	19	17	23
N ₂ O emission, tonnes	0.08	0.09	0.09	0.09	0.09	0.10	0.08	0.04	0.01	0.10
<i>continued</i>	2020									
NH ₃ -N manure management, tonnes	12									
NH ₃ -N inorganic fertilizer, tonnes	9									
NH ₃ -N pasture, tonnes	5									
NH ₃ -N total, tonnes	26									
N ₂ O emission, tonnes	0.14									

Nitrogen leaching and Run-off

The amount of nitrogen lost by leaching and run-off is calculated by using the IPCC default FracLEACH-(H) at 0.3 (IPCC 2006, Table 11.3).

N₂O emission from N-leaching and runoff has increased more than five times from 1990 to 2020.

From 1990 to 2020 total nitrogen content in manure has decreased due to a fall in the number of reindeer and sheep. However, in the same period the use of inorganic fertilisers has increased significantly causing the overall N₂O emission from N-leaching and runoff to increase. The annual use of inorganic fertiliser seems to fluctuate from year to year, causing overall N₂O emission from N-leaching and runoff to vary from year to year as well.

Table 16.5.20 Emission from N-leaching and runoff 1990-2020.

	1990	1991	1992	1993	1994	1995	1996	1997	1998	1999
N-excretion total, tonnes N	154	155	140	122	133	143	147	161	154	138
N in inorganic fertiliser, tonnes	9	9	9	9	9	6	102	28	135	158
N ₂ O emission, tonnes	0.11	0.11	0.10	0.09	0.10	0.09	0.44	0.18	0.55	0.64
<i>continued</i>	2000	2001	2002	2003	2004	2005	2006	2007	2008	2009
N-excretion total, tonnes N	134	137	132	133	140	146	141	144	141	138
N in inorganic fertiliser, tonnes	117	126	114	117	128	136	144	86	273	134
N ₂ O emission, tonnes	0.49	0.52	0.47	0.48	0.53	0.56	0.59	0.39	1.04	0.55
<i>continued</i>	2010	2011	2012	2013	2014	2015	2016	2017	2018	2019
N-excretion total, tonnes N	142	139	138	137	130	122	126	124	127	124
N in inorganic fertiliser, tonnes	120	163	141	136	172	148	134	59	16	146
N ₂ O emission, tonnes	0.50	0.65	0.57	0.55	0.68	0.59	0.54	0.27	0.12	0.58
<i>continued</i>	2020									
N-excretion total, tonnes N	126									
N in inorganic fertiliser, tonnes	162									
N ₂ O emission, tonnes	0.64									

Activity data

Table 16.5.21 provides an overview on activity data from 1990 to 2020 used for the estimation of N₂O emission from agricultural soils. For all emission sources the unit tonnes of nitrogen are used except from cultivation of histosols, where the unit is given as hectare.

Table 16.5.21 Activity data - agricultural soils 1990-2020, tonnes N (cultivation of histosols = ha).

CRF – Table 3.D	1990	1991	1992	1993	1994	1995	1996	1997	1998	1999
A. Direct N ₂ O emissions from managed soils										
Inorganic fertiliser	9	9	9	9	9	6	102	28	135	158
Animal manure applied to soils	53	53	47	43	47	51	53	61	53	55
Urine and dung deposited by grazing animals	82	83	75	64	69	73	75	78	82	64
Crop residue	21	21	19	17	19	20	21	24	21	22
Cultivation of histosols	123	129	136	142	149	155	161	168	174	181
B. Indirect N ₂ O emissions from managed soils										
Atmospheric deposition	1	1	1	1	1	1	5	2	5	5
Nitrogen leaching and run-off	9	9	8	8	8	8	37	16	47	54
<i>continued</i>	2000	2001	2002	2003	2004	2005	2006	2007	2008	2009
A. Direct N ₂ O emissions from managed soils										
Inorganic fertiliser	117	126	114	117	128	136	144	86	273	134
Animal manure applied to soils	54	54	50	51	54	56	56	57	56	53
Urine and dung deposited by grazing animals	62	64	64	65	68	70	66	68	66	67
Crop residue	21	21	20	20	21	22	22	23	22	21
Cultivation of histosols	187	195	214	220	223	232	242	247	252	262
B. Indirect N ₂ O emissions from managed soils										
Atmospheric deposition	5	5	5	5	5	5	2	2	7	5
Nitrogen leaching and run-off	41	44	40	41	45	47	50	33	89	46
<i>continued</i>	2010	2011	2012	2013	2014	2015	2016	2017	2018	2019
A. Direct N ₂ O emissions from managed soils										
Inorganic fertiliser	120	163	141	136	172	148	134	59	16	146
Animal manure applied to soils	55	53	53	53	49	46	48	47	48	47
Urine and dung deposited by grazing animals	68	67	67	66	63	60	62	61	62	61
Crop residue	22	21	21	21	20	18	19	19	19	19
Cultivation of histosols	268	270	273	275	277	282	285	287	291	293
B. Indirect N ₂ O emissions from managed soils										
Atmospheric deposition	5	6	6	6	6	6	5	2	1	6
Nitrogen leaching and run-off	43	55	49	47	57	50	46	23	11	49
<i>continued</i>	2020									
A. Direct N ₂ O emissions from managed soils										
Inorganic fertiliser	162									
Animal manure applied to soils	48									
Urine and dung deposited by grazing animals	62									
Crop residue	19									
Cultivation of histosols	294									
B. Indirect N ₂ O emissions from managed soils										
Atmospheric deposition	9									
Nitrogen leaching and run-off	54									

Time series consistency

N₂O emissions from agricultural soils have increased from 2.9 tonnes N₂O in 1990 to 5.7 tonnes N₂O in 2020 (Table 16.5.22).

Table 16.5.22 Emissions of N₂O from Agricultural Soils 1990–2020, tonnes N₂O.

CRF – Table 3.D	1990	1991	1992	1993	1994	1995	1996	1997	1998	1999
Total N ₂ O emission	2.9	2.9	2.7	2.4	2.6	2.7	4.7	3.4	5.4	5.7
A. Direct N ₂ O emissions from managed soils										
Inorganic fertiliser	0.1	0.1	0.1	0.1	0.1	0.1	1.6	0.4	2.1	2.5
Animal manure applied on soil	0.8	0.8	0.7	0.7	0.7	0.8	0.8	1.0	0.8	0.9
Urine and dung deposited by grazing animals	1.3	1.3	1.2	1.0	1.1	1.2	1.2	1.2	1.3	1.0
Crop residue	0.3	0.3	0.3	0.3	0.3	0.3	0.3	0.4	0.3	0.3
Cultivation of histosols	0.2	0.2	0.2	0.2	0.2	0.2	0.2	0.2	0.2	0.2
B. Indirect N ₂ O emissions from managed soils										
Atmospheric deposition	0.0	0.0	0.0	0.0	0.0	0.0	0.1	0.0	0.1	0.1
Nitrogen leaching and run-off	0.1	0.1	0.1	0.1	0.1	0.1	0.4	0.2	0.6	0.6
<i>continued</i>	2000	2001	2002	2003	2004	2005	2006	2007	2008	2009
Total N ₂ O emission	4.8	5.0	4.7	4.8	5.2	5.4	5.5	4.4	8.0	5.3
A. Direct N ₂ O emissions from managed soils										
Inorganic fertiliser	1.8	2.0	1.8	1.8	2.0	2.1	2.3	1.4	4.3	2.1
Animal manure applied on soil	0.8	0.8	0.8	0.8	0.8	0.9	0.9	0.9	0.9	0.8
Urine and dung deposited by grazing animals	1.0	1.0	1.0	1.0	1.1	1.1	1.0	1.1	1.0	1.0
Crop residue	0.3	0.3	0.3	0.3	0.3	0.4	0.3	0.4	0.3	0.3
Cultivation of histosols	0.2	0.3	0.3	0.3	0.3	0.3	0.3	0.3	0.3	0.3
B. Indirect N ₂ O emissions from managed soils										
Atmospheric deposition	0.1	0.1	0.1	0.1	0.1	0.1	0.0	0.0	0.1	0.1
Nitrogen leaching and run-off	0.5	0.5	0.5	0.5	0.5	0.6	0.6	0.4	1.0	0.5
<i>continued</i>	2010	2011	2012	2013	2014	2015	2016	2017	2018	2019
Total N ₂ O emission	5.1	5.9	5.4	5.3	5.9	5.4	5.1	3.6	2.8	5.4
A. Direct N ₂ O emissions from managed soils										
Inorganic fertiliser	1.9	2.6	2.2	2.1	2.7	2.3	2.1	0.9	0.3	2.3
Animal manure applied on soil	0.9	0.8	0.8	0.8	0.8	0.7	0.8	0.7	0.8	0.7
Urine and dung deposited by grazing animals	1.1	1.1	1.0	1.0	1.0	0.9	1.0	1.0	1.0	1.0
Crop residue	0.3	0.3	0.3	0.3	0.3	0.3	0.3	0.3	0.3	0.3
Cultivation of histosols	0.4	0.4	0.4	0.4	0.4	0.4	0.4	0.4	0.4	0.4
B. Indirect N ₂ O emissions from managed soils										
Atmospheric deposition	0.1	0.1	0.1	0.1	0.1	0.1	0.1	0.0	0.0	0.1
Nitrogen leaching and run-off	0.5	0.7	0.6	0.6	0.7	0.6	0.5	0.3	0.1	0.6
<i>continued</i>	2020									
Total N ₂ O emission	5.7									
A. Direct N ₂ O emissions from managed soils										
Inorganic fertiliser	2.6									
Animal manure applied on soil	0.8									
Urine and dung deposited by grazing animals	1.0									
Crop residue	0.3									
Cultivation of histosols	0.4									
B. Indirect N ₂ O emissions from managed soils										
Atmospheric deposition	0.1									
Nitrogen leaching and run-off	0.6									

16.5.6 Uncertainties

A tier 1 uncertainty assessment has been carried out in accordance with the IPCC Guidelines (IPCC, 2006). The uncertainty has been estimated for all sources included in the reporting for agricultural sector. The uncertainties for the activity data and emission factors are shown in Table 16.5.23.

Table 16.5.23 Uncertainties for activity data and emission factors for agriculture.

Subsector	Pollutant	Activity data uncertainty	Emission factor uncertainty
3A Enteric Fermentation	CH ₄	10	100
3B Manure Management	CH ₄	10	100
3B Manure Management	N ₂ O	10	100
3D Agricultural soils	N ₂ O	20	50
3G Liming	CO ₂	5	50

The resulting uncertainties for the individual greenhouse gases and the total uncertainty on the greenhouse gas emission are shown in Table 16.5.24.

Table 16.5.24 Uncertainties for the emission estimates.

	Uncertainty %	Trend 1990-2020 %	Trend uncertainty %
GHG	± 72	-6.6	± 14.6
CO ₂	± 50	-50.0	± 3.5
CH ₄	± 98	-17.8	± 11.4
N ₂ O	± 48	43.9	± 42.3

16.5.7 Source specific QA/QC

The elaboration of a formal QA/QC plan is to be completed.

However, data on livestock, land-use categories, inorganic fertilisers and cultivation of histosols has gone through a great deal of quality work with regard to accuracy, comparability and completeness.

All external data used for the emission inventory submission are archived in spreadsheets. Data are archived annually in order to ensure that the basic data for a given report are always available in their original form.

Annual data on livestock, land-use categories, inorganic fertilisers and cultivation of histosols are compared with previous years and large discrepancies are checked.

Safely stored and quality checked activity data are then processed by using a methodological approach consistent with international guidelines.

Calculated emission factors are compared with guideline emission factors to ensure that they are reasonable. The calculations follow the principle in international guidelines.

During data processing, it is checked that calculations are being carried out correctly. However, a documentation plan for this needs to be elaborated.

Time series for activity data, emission factors and calculated emissions are used to identify possible errors in the calculation procedure. In fact, during the calculation, numerous controls take place to ensure correctness. Sums are checked of the various stages in the calculation procedure. Implied emission factors are compared to emission factors.

Every single time series imported to the CRF Reporter is checked for annual activity, units for activity, emission factor and emissions. Additional checks are performed on the database. The database encloses every single activity da-

ta, emission factors, emission, notation key and comment imported to the CRF Reporter.

16.5.8 Source specific recalculations and improvements

In this 2022 submission there has been minor revisions in the agricultural sector. These revision are primarily caused by an update of emission factors with regard to synthetic fertilisers and a change in the calculation of emissions from crop residue, see Section 16.5.5.

Table 16.5.25 shows recalculations in the agricultural sector compared to the 2021 submission. Minor changes occur.

Table 16.5.25 Changes in GHG emission in the agricultural sector compared to the 2021 submission.

	1990	1991	1992	1993	1994	1995	1996	1997	1998	1999
Previous inventory, Gg CO ₂ eqv.	9.5	9.6	8.6	7.6	8.3	8.9	9.7	10.2	10.3	9.6
Recalculated, Gg CO ₂ eqv.	9.5	9.6	8.7	7.6	8.3	8.9	9.8	10.2	10.3	9.7
Change in Gg CO ₂ eqv.	0.0	0.0	0.0	0.0	0.0	0.0	0.0	0.0	0.0	0.0
Change in pct.	0.4	0.4	0.4	0.4	0.4	0.4	0.4	0.4	0.4	0.4
<i>continued</i>	2000	2001	2002	2003	2004	2005	2006	2007	2008	2009
Previous inventory, Gg CO ₂ eqv.	9.1	9.3	8.9	9.0	9.5	9.9	9.7	9.6	10.5	9.5
Recalculated, Gg CO ₂ eqv.	9.2	9.4	8.9	9.1	9.6	10.0	9.8	9.6	10.5	9.5
Change in Gg CO ₂ eqv.	0.0	0.0	0.0	0.0	0.0	0.0	0.0	0.0	0.0	0.0
Change in pct.	0.5	0.5	0.5	0.5	0.5	0.5	0.3	0.4	0.3	0.4
<i>continued</i>	2010	2011	2012	2013	2014	2015	2016	2017	2018	2019
Previous inventory, Gg CO ₂ eqv.	9.6	9.7	9.5	9.4	9.1	8.5	8.7	8.1	8.0	8.6
Recalculated, Gg CO ₂ eqv.	9.6	9.7	9.5	9.5	9.2	8.6	8.8	8.2	8.1	8.7
Change in Gg CO ₂ eqv.	0.0	0.0	0.0	0.0	0.0	0.0	0.0	0.0	0.0	0.0
Change in pct.	0.5	0.4	0.5	0.5	0.4	0.5	0.5	0.3	0.5	0.5
<i>continued</i>	2020									
Previous inventory, Gg CO ₂ eqv.	-									
Recalculated, Gg CO ₂ eqv.	8.9									
Change in Gg CO ₂ eqv.	-									
Change in pct.	-									

16.5.9 Source specific planned improvements

The Greenlandic emission inventory for the agricultural sector largely meets the request as set down in the IPCC Good Practice Guidance. Thus for the moment improvements especially concern the QA/QC practice.

16.5.10 References

Greenland Agricultural Consulting Service: Statistics on livestock (sheep and reindeer) and background data on land use (cropland and grassland).

Bussink, D.W. 1994: Relationship between ammonia volatilisation and nitrogen fertiliser application rate, intake and excretion of herbage nitrogen by cattle on grazed swards. *Fertil. Res.* 38, 111-121.

Djurhuus, J. & Hansen, E.M. 2003: Notat vedr. tørstof og kvælstof i efterladte planterester for landbrugsjord - af 21. maj 2003. Forskningscenter Foulum, Tjele. (In Danish).

EEA, 2019: EMEP/EEA air pollutant emission inventory guidebook 2019. Technical guidance to prepare national emission inventories. EEA Report 13/2019. Available at:
<https://www.eea.europa.eu/publications/emep-eea-guidebook-2019>
(07-02-2021).

IPCC, 1997: Revised 1996 IPCC Guidelines for National Greenhouse Gas inventories. Available at:
<http://www.ipcc-nggip.iges.or.jp/public/gl/invs6.htm> (15-04-2007).

IPCC, 2000: Penman, J., Kruger, D., Galbally, I., Hiraishi, T., Nyenzi, B., Emmanuel, S., Buendia, L., Hoppaus, R., Martinsen, T., Meijer, J., Miwa, K. & Tanabe, K. (Eds). Good Practice Guidance and Uncertainty Management in National Greenhouse Gas Inventories. Published: IPCC/OECD/-IEA/IGES, Hayama, Japan. Available at:
<http://www.ipcc-nggip.iges.or.jp/public/gp/english/> (15-04-2007).

IPCC, 2006: 2006 IPCC Guidelines for National Greenhouse Gas Inventories, Prepared by the National Greenhouse Gas Inventories Programme, Eggleston H.S., Buendia L., Miwa K., Ngara T. & Tanabe K. (eds). Published: IGES, Japan. Available at:
<http://www.ipcc-nggip.iges.or.jp/public/2006gl/index.html> (21-02-2014).

Jarvis, S.C., Hatch, D.J. & Roberts, D.H., 1989a: The effects of grassland management on nitrogen losses from grazed swards through ammonia volatilization; the relationship to extral N returns from cattle. *J. Agric. Sci. Camb.* 112,205-216.

Jarvis, S.C., Hatch, D.J. & Lockyer, D.R., 1989b: Ammonia fluxes from grazed grassland annual losses form cattle production systems and their relation to nitrogen inputs. *J. Agric. Camp.* 113, 99-108.

Nielsen, O.-K., Plejdrup, M.S., Winther, M., Nielsen, M., Gyldenkerne, S., Mikkelsen, M.H., Albrektsen, R., Thomsen, M., Hjelgaard, K., Fauser, P., Bruun, H.G., Johannsen, V.K., Nord-Larsen, T., Vesterdal, L., Stupak, I., Scott-Bentsen, N., Rasmussen, E., Petersen, S.B., Olsen, T.M. & Hansen, M.G. 2021: Denmark's National Inventory Report 2021. Emission Inventories 1990-2019 - Submitted under the United Nations Framework Convention on Climate Change and the Kyoto Protocol. 944 pp. - Scientific Report from DCE - Danish Center for Environment and Energy no. 437. Available at:
<https://dce2.au.dk/pub/SR437.pdf>

Rasmussen, H.E., 1992: Reindeer Management in Southern Greenland (1992). Published in Danish as "Den sydgrønlandske rendrift" (1992).

Statistics Greenland, Stat Bank: Data on average temperature in June in Southern Greenland. Available at:
https://bank.stat.gl/pxweb/en/Greenland/Greenland_EN_EN30/

Statistics Greenland, 1990-2020 Data on livestock (sheep and reindeer).

16.6 LULUCF (CRF sector 4)

16.6.1 Overview of LULUCF

This LULUCF chapter covers only the territory of Greenland. Greenland is part of the Danish Kingdom.



Figure 16.6.1 Municipalities and major cities in Greenland.

Greenland is the world's largest non-continental island located on the northern American continent between the Arctic Ocean and the North Atlantic Ocean, northeast of Canada. The northernmost point of Greenland, Cape Morris Jesup, is only 740 km from the North Pole. The southernmost point is Cape Farewell, which lies at about the same latitude as Oslo in Norway. Geographical coordinates are 72 00 N, 40 00 W.

Greenland is covering approximately 2,166,086 km². It has been estimated that 81 % is covered permanently with ice leaving only 410,449 km² ice free. The distance from the South to the North is 2,670 km, and from East to West 1,050 km.

The terrain is flat to gradually sloping ice cap, which covers all but a narrow, mountainous, barren, rocky coast. The ice cap is up to 3 km thick, and contains 10 per cent of the world's resources of freshwater.

The climate is arctic to sub-arctic with cool winters and cold summers in which the mean temperature does not exceed 10° C.

The mean temperature in January is for Nuuk -9.7°, Kangerlussuaq -20.8° and Ilulissat -14.5° (2020) and for July: Nuuk 8.3°, Kangerlussuaq 11.3° and Ilulissat 8.7° (2020).

Greenland is normally defined as having three different climatic zones. For the purpose of reporting is used the definition "Polar and Moist" according to IPCC 2006 Guidelines although some areas may qualify as arctic deserts.

The sparse population is confined to small settlements along the coast, but close to one-quarter of the population lives in the capital, Nuuk. In January 2022 the total Greenlandic population was 56 562 inhabitants.

Due to the cold climate and the small constant population there is almost no land use change occurring. The total area with Forests has been estimated to 218.5 hectares and 10.5 hectares with Cropland. Grassland is divided into improved Grassland covering 1667 hectares and unimproved Grassland covering 240 823 hectares. Wetlands consist of man made water reservoirs - in total 1 076 hectares. Settlements cover 6 046 hectares. Land classified as "Other Land" is then 99.9 % of the total area.

In the following text the abbreviations are used in accordance with definitions in the IPCC guidelines:

- A: Afforestation, areas with forest established after 1990 under Article 3.3.
- R: Reforestation, areas which have temporarily been unstocked for less than 10 years - included under Article 3.4.
- D: Deforestation, areas where forests are permanently removed to allow for other land use, included under Article 3.3.
- FF: Forest remaining Forest, areas remaining forest after 1990.
- FL: Forest Land meeting the definition of forests.
- CL: Cropland.
- GL: Grassland.
- SE: Settlements.
- OL: Other land, unclassified land.
- HWP: Harvested Wood Products.

The LULUCF sector differs from the other sectors in that it contains both sources and sinks of carbon dioxide. LULUCF are reported in the CRF format. Removals are given as negative figures and emissions are reported as positive figures in accordance with the guidelines.

In total the LULUCF sector has been estimated as a net source of 1.339 kt CO₂ equivalents in 2020 equivalent to 0.2 % of the total Greenlandic emission.

The overall land use change from 1990 to 2020 is very small. Afforestation has been made on 14 hectares. No deforestation has occurred and the Cropland area has increased from none to 10.5 hectares.

The emission data are reported in the new CRF format under IPCC categories 4A (Forestry), 4B (Cropland), 4C (Grassland), 4D (Wetlands), 4E (Settlements) and 4F (Other Land).

Fertilisation of forests and other land is not occurring and all fertiliser consumption is therefore reported in the agricultural sector. No drainage of forest soils is made. All liming is reported under Grassland because liming is not occurring in the forests and the very small area with Cropland. Field burning of wooden biomass is not occurring. Wildfires may occur sporadic in the mountains and these are reported as "Other land". Hence, wildfires are reported as NO.

Table 16.6.1 gives an overview of the emission from the LULUCF sector in Greenland. The Forests are a net sink. Cropland is ranging from being zero in 1990 (no Cropland was occurring in 1990) to being a net source in 2020. GL has been estimated to be a net source too. The major emission from CL and GL in 2020 is due to cultivation of organic soils.

Table 16.6.1 Overall emission (kt CO₂ eq) from the LULUCF sector in Greenland, 1990-2020.

	1990	2000	2010	2015	2017	2018	2019	2020
4. Land use, land-use change and forestry	0.26	0.58	1.03	1.13	1.26	1.19	1.28	1.34
A. Forest land	0.05	0.02	0.02	0.00	0.00	0.00	-0.01	-0.01
B. Cropland	NO	NO	0.03	0.05	0.05	0.05	0.05	0.05
C. Grassland	0.21	0.56	0.98	1.08	1.22	1.14	1.24	1.30
D. Wetlands	NO,NE	NO,NE	NO,NE	NO,NE	NO,NE	NO,NE	NO,NE	NO,NE
E. Settlements	NO	NO	NO	NO	NO	NO	NO	NO
F. Other land	NO	NO	NO	NO	NO	NO	NO	NO
G. Harvested wood products	NO	NO	NO	NO	NO	NO	NO	NO

16.6.2 Forest remaining forest (4A1)

Forests and forest management

Greenland has virtually no forests and therefore there exist no official forest statistics. All forests are situated in the most southern part of Greenland. In an attempt to introduce trees to Greenland research were carried out to find species adaptable to the Greenlandic climate. This resulted in establishment of the Greenlandic Arboretum, which covers 150 hectares out of the total area of 218.5 hectares, Figure 16.6.2 and Table 16.6.2. Information about the Greenlandic Arboret can be found at

<http://ign.ku.dk/om/arboreter/arboret-groenland/skovplantninger>



Figure 16.6.2 The position of the Greenlandic forests (Courtesy to Rasmus Enoksen Christensen).

Table 16.6.2 Forests in Greenland 1990 and 2020.

Location	Established	Dominant tree	Area, ha	1990 average tree height (m)	2020 average tree height (m)	Density 1990 (trees pr ha)	Density 2020 (trees pr ha)
Qinngua Valley	Natural	Birch and mountain ash	45	n.a	6	100	100
Qanassiassat Forest	1953-63	Conifer	1	5	13.8	1500	1000
Kuussuaq Forest	1962-64 -1982	Conifer	5	3	13.6	1300	900
Kuussuaq Forest	2008	Conifer	3	***	< 1	***	3500
Greenland Arboretum	(1976-1980)	Conifer	3	4	7	300	300
Greenland Arboretum	1980 -	Conifer	150	2	3	1500	1700
Itilleq	2004-2005	Conifer	6	***	< 1	***	3500
Upernaviarsuk	1954	Conifer	0,5	1,5	3	200	200
Lejrskolen	1999-2005	Conifer	4	***	1	***	2500
Klosterdalen	2000	Conifer	1	***	1	***	2000
Total			218.5				

Forest definition

The forest definition adopted in Greenland is almost identical to the FAO definition (TBFRA, 2000). It includes “wooded areas larger than 0.5 ha, that are able to form a forest with a height of at least 5 m and crown cover of at least 10 %. The minimum width is 20 m.” Temporarily non wooded areas, fire breaks, and other small open areas, that are an integrated part of the forest, are also included. However, due to extreme slow growing rates many of the forests are currently below 5 meters height.

Figure 16.6.3 shows a picture of the best developed forest in Greenland.



Figure 16.6.3 The forest in Kuusuaq. Photo: Rasmus E. Christensen, 2005.

Of special interest is the forest in Qinngua Valley. The Qinngua Valley is situated in a remote area. It consists of natural birch (*Betula pubescens* spp. *czerepanovii* and *B. glandulosa*.) which develops to forest like trees probably due to an introgressiv hybridisation (Rasmus Enoksen Christensen). This forest will probably not follow the FAO forest definition but are included in the inventory as a sub-division under forests. The Qinngua-valley is not included in the FAO forest statistics.



Figure 16.6.4 Kuusuaq, Tasermiut fjor. Photo: Rasmus Christensen, Juni 2004.

Methodological issues for forests

Estimation of volume, biomass and carbon pools

Due to lack of precise data and slow growth rates, simple functions are used that only include the height of the trees and the number per hectare.

The height of the trees has been estimated by Rasmus Enoksen Christensen based on data from the Aboretum. It is assumed that the trees are conical and the stem diameter at ground level is based on the general formula for even-aged forests (Vanclay, 2009).

$$D = \beta(H - 1.3) / \ln(N) \quad (\text{eq.1})$$

Where:

D = diameter at breast height, cm

β = slope, species dependent

H = Height of the trees (meters)

N = Number of trees per hectare

Eq. 1 has been simplified by omitting the breast height (1.3 meters) to

$$D = \beta(H) / \ln(N) \quad (\text{eq.2})$$

so that D is representing the diameter at ground level. The β -value used is given in Table 16.6.3.

Table 16.6.3 β -values for estimating the diameter of trees (from Vanclay, 2009).

	Betula, spp	Conifers
β -values	6.54	7.51

In order to estimate the C stock and C stock change is used the average default values from the IPCC 2006 guidelines for BCEF, density, C-content and Root-Shoot ratio for Boreal stands with a growing stock level of 21-50 m³, IPCC table 4.5, pp 4.50. The values are given in Table 16.6.4.

Table 16.6.4 Biomass expansion factors used for Greenland.

		Qinngua Walley (Betula, spp.) Birch	Conifers	Orpiuteqarfia (Larix sibirica) Siberian Larch)
BCEF	Dimensionless	0.7	0.66	0.78
Density	kg dry matter per litre	0.51	0.4	0.46
C-content	kg C per kg dry matter	0.48	0.51	0.51
Root-shoot-ratio	Dimensionless	0.39	0.39	0.39
Dead Organic Matter	kg per kg aboveground biomass	0.1	0.2	0.1

Source: IPCC 2006 guidelines.

Dead wood volume, biomass and carbon

The volume of dead organic matter (DOM) is estimated as a fraction of the aboveground biomass (Table 16.6.4). It is assumed that litter is included in DOM.

Forest soils: forest floors and mineral soil

Following the cold climate and the slow growing rate it is assumed that no changes takes place in C-stock in the soil and hereby following the IPCC 2006 guidelines at Tier 1 level.

Uncertainties and time series consistency

The uncertainty in estimation of the C stock changes in the Greenlandic forests is very high. As there are very limited resources to visit and monitor in the remote areas there are very few data available. The current inventory is therefore based on the best knowledge available. It should also be taken into consideration that the importance of the forest sector in Greenland is marginal as only very little thinning is taking place as well as no deforestation and that the effect on the inventory is almost not measurable.

In the overall uncertainty section for the LULUCF is made a Tier 1 uncertainty analysis.

QA/QC and verification

Focus on the measurements of carbon pools in forest in Greenland will contribute to QA/QC and verification, but presently there are no plans to a further monitoring of the Greenlandic forests.

Recalculations and changes made in response to the review process

No recalculations have been made.

Planned improvements

No improvements are planned.

16.6.3 Land converted to forests (4A2)**Forest area**

See Section 16.2.1 Information on approaches used for representing land areas and on land-use databases used for the inventory preparation.

Forest definition

See Section 16.2.1 Land-use definitions and the classification systems used and their correspondence to the LULUCF categories (e.g. land use and land-use change matrix).

Methodological issues for land converted to forest

See also Section 16.2.1.

Since 1990, there has been a slight increase in the forest area of 14 hectares. This has taken place on land converted from "OL".

Uncertainties and time series consistency

For time series consistency, see Section 16.2.1. For uncertainties, please see Chapter 16.6.15.

QA/QC and verification

No QA/QC plan has been made yet. The afforested area is known.

Recalculations, including changes made in response to the review process

None

Planned improvements

No improvements are planned.

16.6.4 Cropland (4B)**Cropland and cropland management (4B1)**

In 1990 there were no cropland occurring in Greenland. Due to global warming, it is now possible to have a few crops, which may mature. In 2001, the first five hectares with annual crops were established. These are reported under 5.B.2. A more intensive description of the agriculture in Greenland can be found at

<http://nunalerineq.gl/english/landbrug/jord/index-jord.htm>

Land converted to cropland (4B2)

In 2001, the first annual crops were grown in Greenland. Approximately five hectares with garden crops were grown. Of this it is assumed that 25 % of the area is on organic soils (pers. comm. with Kenneth Høeg, former chief agricultural advisor in Greenland). The area converted to cropland was improved grassland.



Figure 16.6.5 Cropland and Grassland in Greenland.
(Photos from: <http://nunalerineq.gl/english/landbrug/landbrug/index-landbrug.htm>).

The region is generally characterized by a slightly podsol type of soil with a low pH value and small amounts of accessible plant nutrients. Larger concentrations of clay rarely occur, but considerable quantities of silt are often observable on the surface. Also, a certain amount of brown earth occurs in inland areas.

Methodological issues

Change in carbon stock in living biomass

For land converted to cropland is used a standard default value of 5,000 kg DM (dry matter) per hectare in above- and below-ground (IPCC 2006).

Change in carbon stock in dead organic matter

No organic matter is reported under CL.

Change in carbon stock in soils

No C stock changes in mineral soils are assumed. The emission in the 25 % organic soils is estimated by using the IPCC 2006 default value for cropland, Table 5.6 pp 5.19 of 5,000 kg C per ha per year. The emission factors for organic soils in the 2013 Supplement to the 2006 IPCC Guidelines for National Greenhouse Gas Inventories: Wetlands (IPCC 2014a) are based on expert judgement assumed to be too high for the cold conditions in Greenland.

Uncertainties and time series consistency

The time series are complete. For uncertainties, please see Chapter 16.6.15.

Category-specific QA/QC and verification

The number of hectares is provided by the Greenlandic Agricultural Consulting Services. As agricultural activities are economically subsidised in Greenland the figures are very accurate.

Category-specific recalculation

No recalculations have been made.

Category-specific planned improvements

No improvements are planned.

16.6.5 Grassland (4C)**Grassland remaining grassland (4C1)**

Grassland in Greenland is dominated by unimproved grassland where the sheep is grazing. The total area with GL has been estimated to 241,990 hectares. Of these, only approximately 1,667 hectare is improved where stones have been removed combined with sowing of more high yielding species, see Figure 16.6.5.

Since 1990, the area with improved grassland has been extended from 490 hectares to 1,667 hectares.

Methodological issues for grassland

Grassland is divided into improved and unmanaged Grassland.

Change in carbon stock in living biomass

As more GL becomes improved the amount of living biomass at peak is increased. To estimate the amount of living biomass in improved GL is using the same default value as for Cropland, e.g. 5000 kg DM per hectare, IPCC 2006 default value for cropland, Table 5.9 pp 5.28. For unmanaged Grassland is used a default value of 1700 kg DM per hectare according to IPCC 2006 default, Table 6.4 pp 6.27. No estimates for below-ground biomass are given. For conversion from DM to C is used a default value of 0.5 kg C per kg DM.

Change in carbon stock in dead organic matter

No changes in dead organic matter are estimated as this is not occurring for this category.

Change in carbon stock in soils

No changes in the carbon stock in mineral soils are assumed. For organic soils on improved grassland is used a default EF of 1,250 kg C per ha per year (IPCC, 2006) default value for grassland, Table 6.3 pp 6.17. For unmanaged grassland no carbon stock change is expected. The emission factors for organic soils in the 2013 Wetland Supplement to the 2006 IPCC Guidelines for National Greenhouse Gas Inventories: Wetlands (IPCC 2014a) are based on expert judgement assumed to be too high for the cold conditions in Greenland.

Uncertainties and time series consistency

The time series is complete. For uncertainties, please see Chapter 16.6.15.

Category-specific QA/QC and verification

The number of hectares is provided by the Greenlandic Agricultural Consulting Services. As the agriculture is subsidised in Greenland the figures are very accurate.

Recalculations

No recalculation has been made.

Planned improvements

No improvements are planned.

16.6.6 Wetlands (4D)

Wetland in Greenland includes only human made water reservoirs and not naturally occurring wetlands. In total 1,076 hectares with ponds and water reservoirs distributed on 48 locations are reported.

No emission estimates from these reservoirs has been made yet.

Uncertainties and time series consistency

Not estimated.

QA/QC and verification

QA and QC have been made by DCE and Statistics Greenland.

Recalculations

No recalculations have been made.

Category-specific planned improvements

No improvements are planned.

16.6.7 Settlements (4E)

In total there are approximately 56,000 inhabitants in Greenland with about one quarter of the population in the capital, Nuuk.

Table 16.6.5 Inhabitants and the area occupied with houses, hectares.

	1990	2000	2015	2020
Inhabitants	55 589	56 176	55 916	56 421
Settlements, total, ha	4801	4891	5761	6046

The cities are build on the rocky coastline where almost none vegetation occurs. As a consequence, estimates for C stock in living biomass and in soil have been made.

The small increase in the area with Settlements since 1990 has taken place on "Other land".

Currently, no official data or measurements of the area of villages and settlements are available. Alternatively, land utilized for villages and settlements have been measured by the use of NunaGIS, which is a digital internet atlas displaying maps over villages and settlements in Greenland. NunaGIS is available at www.nunagis.gl.

16.6.8 Other land (4F)

The major part of Greenland is covered with snow or rocks. Thus, Other Land consists of 99.9 % of the total area.

No emission estimates have been made for this area.

The global warming can be seen in Greenland with longer and warmer summers, which again increase the amount of living biomass. Especially since the early 1990's there has been changes observed in the environment, e.g. as given in the area with Cropland and Grassland has increased. However, no methodology exists currently to estimate a proper estimate of the amount of living biomass in the large area classified as "Other land".

16.6.9 Harvested Wood Products (4G)

Due to the very low area with slowgrowing forests and the constant Greenlandic population is it assumed that no national changes in the carbon stock in Harvested Wood Products (HWP) are taking place.

16.6.10 Direct nitrous oxide (N₂O) emissions from nitrogen (N) inputs to managed soils– 4(I)

Reported under 3.D.

16.6.11 Emissions and removals from drainage and rewetting and other management of organic and mineral soils – 4(II)

Not estimated

16.6.12 Direct nitrous oxide (N₂O) emissions from nitrogen (N) mineralization/immobilization associated with loss/gain of soil organic matter - 4(III)

Not occurring.

16.6.13 Indirect nitrous oxide (N₂O) emissions from managed soils– 4(IV)

Reported under 3.D.

16.6.14 Biomass burning – 4(V)

No biomass burning takes place in Greenland, and wildfires rarely occur due to the moist climate.

16.6.15 Uncertainties

A tier 1 uncertainty assessment has been carried out in accordance with the IPCC GPG (IPCC, 2000). The uncertainty has been estimated for all sources included in the reporting for LULUCF. The uncertainties for the activity data and emission factors are shown in Table 16.6.6.

Table 16.6.6 Uncertainties for activity data and emission factors for LULUCF.

Subsector	Pollutant	Activity data uncertainty	Emission factor uncertainty
4A Forest	CO ₂	5	50
4B Cropland	CO ₂	5	50
4C Grassland	CO ₂	5	50
4A Forest	CH ₄	5	50
4C Grassland	CH ₄	5	50
4A Forest	N ₂ O	5	50

The assumed uncertainties represent expert judgement.

The resulting uncertainties for the individual greenhouse gases and the total uncertainty on the greenhouse gas emission are shown in Table 16.6.7.

Table 16.6.7 Uncertainties for the emission estimates.

	Uncertainty %	Trend 1990-2020 %	Trend uncertainty %
GHG	± 49	410.6	± 80.4
CO ₂	± 51	519	± 49.0
CH ₄	± 50	5.6	± 7.5

16.6.16 References

Christensen, R.E. 2010: Information on Greenlandic forests. Not published.

IPCC, 2006: 2006 IPCC Guidelines for National Greenhouse Gas Inventories, Prepared by the National Greenhouse Gas Inventories Programme, Eggleston, H.S., Buendia, L., Miwa, K., Ngara, T. & Tanabe, K. (eds). Published: IGES, Japan. Available at:

<http://www.ipcc-nggip.iges.or.jp/public/2006gl/index.html>

IPCC 2014a, 2013 Supplement to the 2006 IPCC Guidelines for National Greenhouse Gas Inventories: Wetlands, Hiraishi, T., Krug, T., Tanabe, K., Srivastava, N., Baasansuren, J., Fukuda, M. and Troxler, T.G. (eds). Published: IPCC, Switzerland.

Vanclay, J.K. 2009: Tree diameter, height and stocking in even-aged forests, *Ann. For. Sci.* 66. 702 Available online at: EDP Sciences, 2009. Available at: www.afs-journal.org DOI: 10.1051/forest/2009063.

16.7 Waste (CRF sector 5)

16.7.1 Overview of sector

The waste sector consists of the CRF source category 5.A. Solid Waste Disposal, 5.C. Incineration and Open Burning of Waste and 5.D. Wastewater Treatment and Discharge.

In CO₂ equivalents, the waste sector (without LULUCF) contributes with 2.8 % of the overall greenhouse gas emission in 2020. This corresponds to an emission of 16.0 Gg CO₂ equivalents.

The Greenlandic inventory includes CH₄ emissions from managed and unmanaged waste disposal sites on land, N₂O from wastewater and CO₂, CH₄, N₂O, NO_x, CO, NMVOC and SO₂ from open burning and waste incineration and open burning. Only emissions from waste incineration without energy recovery are included in the waste sector. Emissions from waste incineration with energy recovery are included in the energy sector.

Table 16.7.1 shows the greenhouse gas emissions from the waste sector. The emissions are taken from the CRF tables and are presented as rounded figures.

Table 16.7.1 Emissions from the waste sector, Gg CO₂ equivalents.

		1990	1991	1992	1993	1994	1995	1996	1997	1998	1999
5A Solid waste disposal	CH ₄	4.6	4.6	4.7	4.8	4.9	4.9	5.0	5.1	5.1	5.2
5B Incineration and open burning	CO ₂	2.6	2.6	2.6	2.6	2.7	2.7	2.9	3.1	3.5	3.4
5B Incineration and open burning	CH ₄	2.7	2.7	2.7	2.8	2.8	2.8	2.8	2.8	2.6	2.5
5B Incineration and open burning	N ₂ O	0.7	0.7	0.8	0.8	0.8	0.8	0.8	0.8	0.8	0.7
5C Wastewater treatment and discharge	N ₂ O	7.2	7.2	7.1	7.1	7.2	7.2	7.2	7.2	7.2	7.2
5. Waste total		17.7	17.8	17.9	18.0	18.2	18.4	18.6	18.9	19.2	18.9
<i>continued</i>		2000	2001	2002	2003	2004	2005	2006	2007	2008	2009
5A Solid waste disposal	CH ₄	5.2	5.2	5.2	5.2	5.1	5.1	5.0	5.0	5.0	4.9
5B Incineration and open burning	CO ₂	3.2	3.3	3.2	3.1	3.1	3.1	3.1	3.1	3.1	3.1
5B Incineration and open burning	CH ₄	2.1	2.1	2.1	1.9	1.9	1.9	1.9	1.9	1.9	1.9
5B Incineration and open burning	N ₂ O	0.6	0.6	0.6	0.6	0.5	0.5	0.6	0.6	0.5	0.6
5C Wastewater treatment and discharge	N ₂ O	7.2	7.2	7.2	7.2	7.2	7.2	7.2	7.3	7.6	6.3
5. Waste total		18.3	18.4	18.2	18.0	17.8	17.8	17.8	17.8	18.1	16.7
<i>continued</i>		2010	2011	2012	2013	2014	2015	2016	2017	2018	2019
5A Solid waste disposal	CH ₄	4.9	4.9	4.9	4.8	4.8	4.8	4.8	4.8	4.8	4.7
5B Incineration and open burning	CO ₂	3.1	3.2	3.2	3.3	3.4	3.4	3.4	3.4	3.4	3.4
5B Incineration and open burning	CH ₄	1.9	1.9	1.9	1.9	1.9	1.9	1.9	1.9	1.9	1.9
5B Incineration and open burning	N ₂ O	0.6	0.6	0.6	0.6	0.6	0.6	0.6	0.6	0.6	0.6
5C Wastewater treatment and discharge	N ₂ O	6.0	6.1	5.7	4.6	4.4	4.2	4.8	4.8	4.9	5.0
5. Waste total		16.5	16.6	16.2	15.2	15.0	14.8	15.4	15.4	15.6	15.7
<i>continued</i>		2020									
5A Solid waste disposal	CH ₄	4.7									
5B Incineration and open burning	CO ₂	3.4									
5B Incineration and open burning	CH ₄	1.9									
5B Incineration and open burning	N ₂ O	0.6									
5C Wastewater treatment and discharge	N ₂ O	5.3									
5. Waste total		16.0									

The largest sources of greenhouse gas emission from the waste sector in 2020 are N₂O emission from waste water treatment and discharge (32.9 %) and CH₄ emission from solid waste disposal (29.7 %) followed by CO₂ from waste incineration and open burning (21.6 %).

Total greenhouse gas emission from the waste sector has decreased by 9.8 % since 1990. In 2020 emissions from all sources were more or less unchanged. However, emissions from waste water treatment increased by 4.0 %.

16.7.2 Solid waste management

Activity data for waste amounts for solid waste management are shown in Table 16.7.2.

Table 16.7.2 Waste amounts for solid waste management, tonnes.

	1990	1991	1992	1993	1994	1995	1996	1997	1998	1999
5A1 Managed waste disposal sites	6 057	6 126	6 170	6 233	6 335	6 430	6 412	6 418	6 150	5 704
5A2 Unmanaged waste disposal sites	1 361	1 358	1 356	1 359	1 340	1 288	1 215	1 159	1 060	986
5C1 Incineration, with energy recovery	5 520	5 579	5 619	5 734	5 919	6 073	6 179	6 276	6 403	8 208
5C1 Incineration, without energy rec.	0	0	0	0	56	225	795	1 240	2 666	2 899
5C2 Open burning of waste	16 567	16 714	16 808	16 956	17 140	17 236	17 033	16 922	16 101	14 941
5. Waste total	29 505	29 777	29 953	30 281	30 789	31 251	31 635	32 016	32 380	32 738
<i>continued</i>	2000	2001	2002	2003	2004	2005	2006	2007	2008	2009
5A1 Managed waste disposal sites	4 880	4 945	4 750	4 455	4 216	4 248	4 267	4 296	4 321	4 355
5A2 Unmanaged waste disposal sites	906	865	839	830	825	824	815	788	756	738
5C1 Incineration, with energy recovery	11 283	11 526	12 658	14 084	15 312	15 576	15 791	16 060	16 371	16 691
5C1 Incineration, without energy rec.	3 148	3 306	3 390	3 415	3 437	3 461	3 485	3 468	3 444	3 466
5C2 Open burning of waste	12 924	12 976	12 481	11 803	11 259	11 329	11 351	11 355	11 338	11 374
5. Waste total	33 142	33 618	34 118	34 587	35 049	35 437	35 709	35 968	36 229	36 624
<i>continued</i>	2010	2011	2012	2013	2014	2015	2016	2017	2018	2019
5A1 Managed waste disposal sites	4 418	4 481	4 507	4 520	4 549	4 569	4 589	4 633	4 693	4 748
5A2 Unmanaged waste disposal sites	718	687	654	629	600	576	569	549	527	509
5C1 Incineration, with energy recovery	17 082	17 505	17 860	18 137	18 401	18 685	18 996	19 322	19 660	20 041
5C1 Incineration, without energy rec.	3 486	3 488	3 501	3 523	3 550	3 548	3 557	3 592	3 616	3 628
5C2 Open burning of waste	11 470	11 541	11 526	11 498	11 499	11 491	11 519	11 573	11 658	11 739
5. Waste total	37 174	37 702	38 048	38 307	38 600	38 869	39 230	39 669	40 153	40 664
<i>continued</i>	2020									
5A1 Managed waste disposal sites	4 786									
5A2 Unmanaged waste disposal sites	500									
5C1 Incineration, with energy recovery	20 509									
5C1 Incineration, without energy rec.	3 653									
5C2 Open burning of waste	11 806									
5. Waste total	41 254									

Waste amounts are based on municipal data on waste and waste incineration with energy recovery on local incinerator plants in 2004, and a survey by Consulting Company Carl Bro in 1996 and 2001, where waste amounts per person per year was identified as 650 kg and 455 kg for Greenlandic towns and settlements, respectively. For the time series these amounts were regulated by 1 % per year upwards for years after 2004 and by 1 % per year downwards for years before 2004. Further, to construct the time series statistical data from Statistics Greenland on population in towns and settlements were used. Other results of the survey used for the time series are that it was estimated that (1) 70 % of waste amounts is incinerated and 30 % deposited and (2) 80 % of combustible waste amounts deposited is burned in open burning.

Solid waste disposal

Source Category Description

The category consists of managed and unmanaged disposal sites of waste on land.

Methodological issues, activity data, emission factors and emissions

In Table 16.7.3 the composition of the waste according to the survey mentioned is shown.

Table 16.7.3 Composition of household and commercial waste before and after open burning.

Fraction	Household waste ²	Commercial waste ²	Household / Commercial Weighted	After open burning	Weighted (after open burning)
%					
Paper/cardboard, dry	8.00 ¹	20.00	11.84	2.37	7.66
Paper/cardboard, wet	10.00 ¹	7.00	9.04	1.81	5.85
Plastics	7.00 ¹	9.00	7.64	1.53	4.94
Organic waste	44.00 ¹	34.00	40.80	8.16	26.38
Other combustible	17.50 ¹	16.00	17.02	3.40	11.01
Glass	7.50 ¹	3.00 ¹	6.06	6.06	19.59
Metal	3.50 ¹	3.00 ¹	3.34	3.34	10.80
Other, non combustible	1.00 ¹	5.00	2.28	2.28	7.37
Hazardous waste	1.50 ¹	3.00 ¹	1.98	1.98	6.40
Total	100.00	100.00	100.00	30.93	100.00
Pct (%)	68 ³	32 ³		80 ⁴	

Notes:

¹ Measured values.

² Source: Former Environmental and Nature Agency, Ministry of Infrastructure and Environment. Survey from 2004.

³ Distribution of household and commercial waste.

⁴ Share of combustible waste burned at waste disposal sites.

A Tier 2 approach with a first order decay model is used for estimation of emissions of CH₄ from the solid waste disposals. For this purpose the activity data in Table 16.7.2 are estimated back to 1960 (not shown) based on the methodology described in connection to Table 16.7.2. Combining these activity data and the composition data in Table 16.7.3 time series for 1960-2020 with amounts of waste in waste fractions is calculated.

For these time series the waste fractions are associated to (1) Dissolved Organic Carbon (DOC) values according to Section 16.7.2 of this NIR and (2) emission factors based on DOC values and values of methane correction factors, fraction of DOC dissimilated and fraction of CH₄ in gas emitted according to the IPCC 2006 Guidelines (Table 2.4) and GPG for managed disposals, Table 16.7.4 and unmanaged disposals, Table 16.7.5.

Table 16.7.4 DOC values and emission factors for CH₄ for managed disposals.

	Paper / cardboard, dry	Paper / cardboard, wet	Plastics	Organic waste	Other combustible	Glass	Metal	Other, non combustible	Hazardous waste
DOC weighted (after open burning) fraction	0.44	0.40	0.00	0.15	0.24	0.00	0.00	0.00	0.00
Emission factor kg CH ₄ /tonnes ¹	146.7	133.3	0.0	50.0	80.0	0.0	0.0	0.0	0.0
¹) based on:									
Methane correction factor				1					
Fraction of DOC dissimilated and emitted				0.5					
Fraction of CH ₄ in gas emitted				0.5					

Table 16.7.5 DOC values and emission factors for CH₄ for unmanaged disposals.

	Paper/ cardboard dry	Paper/ cardboard wet	Plastics	Organic waste	Other combustible	Glass	Metal	Other, non- combustible	Hazardous waste
DOC weighted (after open burning) fraction	0.44	0.40	0.00	0.15	0.24	0.00	0.00	0.00	0.00
Emission factor kg CH ₄ /tonnes ¹	58.7	53.3	0.0	20.0	32.0	0.0	0.0	0.0	0.0
1) based on:									
Methane correction factor				0.4					
Fraction of DOC dissimilated and emitted				0.5					
Fraction of CH ₄ in gas emitted				0.5					

For managed and unmanaged disposals the default half life time of 14 years and a time lag of 0.5 years are used. For the oxidation factor and according to the GPG for managed disposal 0.1 and for unmanaged 0.0 are used.

In Tables 16.7.6 and 16.7.7 selected data and results are shown for 1990-2020 for managed and unmanaged disposal, respectively. The data in the tables are as follows. The AD for the FOD model as amounts of waste in fractions, the potential emission of CH₄ calculated with emission factors on waste amounts in fractions, the annual generated emission of CH₄ calculated with the FOD model using the potential emissions, the oxidized CH₄ and the actual annual CH₄ emission calculated as the annual generated emission minus the CH₄ oxidized. Calculations are performed since 1960 and are not shown.

Table 16.7.6 Managed disposal. AD for the FOD model (amount of waste in fractions), potential emission of CH₄, oxidized CH₄ and annual CH₄ emission 1990-2020.

Unit	Paper/ cardboard dry Tonnes	Paper/ cardboard wet Tonnes	Plastics Tonnes	Organic waste Tonnes	Other com- bustible Tonnes	Glass Tonnes	Metal Tonnes	Other, non com- bustible Tonnes	Hazardous waste Tonnes	Waste total Tonnes	Potential emission Tonnes CH ₄	Annual generated emission Tonnes CH ₄	Annual oxidized emission Tonnes CH ₄	Annual emission Tonnes CH ₄
1990	464	354	299	1 598	667	1 187	654	447	388	6 057	244.6	183.8	18.4	165.4
1991	469	358	303	1 616	674	1 200	662	452	392	6 126	248.5	186.9	18.7	168.2
1992	472	361	305	1 628	679	1 209	666	455	395	6 170	251.3	190.0	19.0	171.0
1993	477	364	308	1 645	686	1 221	673	460	399	6 233	253.1	193.1	19.3	173.8
1994	485	370	313	1 671	697	1 241	684	467	406	6 335	255.7	196.1	19.6	176.5
1995	492	376	318	1 696	708	1 260	694	474	412	6 430	259.9	199.2	19.9	179.3
1996	491	375	317	1 692	706	1 256	692	473	410	6 412	263.8	202.3	20.2	182.1
1997	491	375	317	1 693	706	1 258	693	473	411	6 418	263.0	205.2	20.5	184.7
1998	471	359	304	1 622	677	1 205	664	453	394	6 150	263.3	208.0	20.8	187.2
1999	437	333	282	1 505	628	1 118	616	420	365	5 704	252.3	210.2	21.0	189.2
2000	374	285	241	1 288	537	956	527	360	312	4 880	234.0	211.3	21.1	190.2
2001	379	289	244	1 305	544	969	534	365	317	4 945	200.2	210.8	21.1	189.7
2002	364	278	235	1 253	523	931	513	350	304	4 750	202.9	210.4	21.0	189.4
2003	341	260	220	1 175	490	873	481	328	285	4 455	194.8	209.7	21.0	188.7
2004	323	246	208	1 112	464	826	455	311	270	4 216	182.7	208.4	20.8	187.5
2005	325	248	210	1 121	468	832	459	313	272	4 248	172.9	206.6	20.7	186.0
2006	327	249	211	1 126	470	836	461	315	273	4 267	174.3	205.1	20.5	184.6
2007	329	251	212	1 133	473	842	464	317	275	4 296	175.0	203.6	20.4	183.3
2008	331	253	213	1 140	476	847	467	319	277	4 321	176.2	202.3	20.2	182.1
2009	333	255	215	1 149	479	853	470	321	279	4 355	177.2	201.1	20.1	181.0
2010	338	258	218	1 166	486	866	477	326	283	4 418	178.6	200.0	20.0	180.0
2011	343	262	221	1 182	493	878	484	330	287	4 481	181.2	199.1	19.9	179.2
2012	345	263	223	1 189	496	883	487	332	289	4 507	183.8	198.4	19.8	178.5
2013	346	264	223	1 193	497	886	488	333	289	4 520	184.9	197.7	19.8	177.9
2014	348	266	225	1 200	501	891	491	335	291	4 549	185.4	197.1	19.7	177.4
2015	350	267	226	1 206	503	895	493	337	293	4 569	186.6	196.6	19.7	177.0
2016	351	268	227	1 211	505	899	496	338	294	4 589	187.4	196.2	19.6	176.6
2017	355	271	229	1 222	510	908	500	342	297	4 633	188.2	195.8	19.6	176.2
2018	359	274	232	1 238	517	920	507	346	300	4 693	190.0	195.5	19.6	176.0
2019	364	278	235	1 253	523	930	513	350	304	4 748	192.5	195.4	19.5	175.8
2020	366	280	236	1 263	527	938	517	353	306	4 786	194.8	195.3	19.5	175.8

Table 16.7.7 Unmanaged disposal. AD for the FOD model (amount of waste in fractions), potential emission of CH₄, oxidized CH₄ and annual CH₄ emission 1990-2020.

Unit	Paper/ cardboard dry Tonnes	Paper/ cardboard wet Tonnes	Plastics Tonnes	Organic waste Tonnes	Other com- bustible Tonnes	Glass Tonnes	Metal Tonnes	Other, non combustible Tonnes	Hazardous waste Tonnes	Waste total Tonnes	Potential emission Tonnes CH ₄	Annual generated emission Tonnes CH ₄	Annual oxidized emission Tonnes CH ₄	Annual emission Tonnes CH ₄
1990	104	80	67	359	150	267	147	100	87	1 361	22.3	16.6	0.0	16.6
1991	104	79	67	358	149	266	147	100	87	1 358	22.3	16.9	0.0	16.9
1992	104	79	67	358	149	266	146	100	87	1 356	22.3	17.1	0.0	17.1
1993	104	79	67	358	150	266	147	100	87	1 359	22.3	17.4	0.0	17.4
1994	103	78	66	354	147	263	145	99	86	1 340	22.3	17.6	0.0	17.6
1995	99	75	64	340	142	252	139	95	82	1 288	22.0	17.8	0.0	17.8
1996	93	71	60	321	134	238	131	90	78	1 215	21.1	18.0	0.0	18.0
1997	89	68	57	306	128	227	125	85	74	1 159	19.9	18.1	0.0	18.1
1998	81	62	52	280	117	208	114	78	68	1 060	19.0	18.1	0.0	18.1
1999	76	58	49	260	109	193	107	73	63	986	17.4	18.1	0.0	18.1
2000	69	53	45	239	100	178	98	67	58	906	16.2	18.0	0.0	18.0
2001	66	51	43	228	95	170	93	64	55	865	14.9	17.9	0.0	17.9
2002	64	49	41	221	92	164	91	62	54	839	14.2	17.7	0.0	17.7
2003	64	49	41	219	91	163	90	61	53	830	13.8	17.5	0.0	17.5
2004	63	48	41	218	91	162	89	61	53	825	13.6	17.3	0.0	17.3
2005	63	48	41	217	91	162	89	61	53	824	13.5	17.1	0.0	17.1
2006	62	48	40	215	90	160	88	60	52	815	13.5	16.9	0.0	16.9
2007	60	46	39	208	87	154	85	58	50	788	13.4	16.8	0.0	16.8
2008	58	44	37	200	83	148	82	56	48	756	12.9	16.6	0.0	16.6
2009	57	43	36	195	81	145	80	54	47	738	12.4	16.4	0.0	16.4
2010	55	42	35	189	79	141	78	53	46	718	12.1	16.2	0.0	16.2
2011	53	40	34	181	76	135	74	51	44	687	11.8	16.0	0.0	16.0
2012	50	38	32	173	72	128	71	48	42	654	11.3	15.7	0.0	15.7
2013	48	37	31	166	69	123	68	46	40	629	10.7	15.5	0.0	15.5
2014	46	35	30	158	66	117	65	44	38	600	10.3	15.2	0.0	15.2
2015	44	34	28	152	63	113	62	42	37	576	9.8	15.0	0.0	15.0
2016	44	33	28	150	63	112	61	42	36	569	9.5	14.7	0.0	14.7
2017	42	32	27	145	60	108	59	40	35	549	9.3	14.5	0.0	14.5
2018	40	31	26	139	58	103	57	39	34	527	9.0	14.2	0.0	14.2
2019	39	30	25	134	56	100	55	38	33	509	8.6	13.9	0.0	13.9
2020	38	29	25	132	55	98	54	37	32	500	8.3	13.7	0.0	13.7

16.7.3 Incineration and open burning of waste

Source category description

In Greenland waste incineration is carried out both with and without energy recovery. According to IPCC Guidelines the emissions associated with waste incineration for energy production is included in the energy sector more specifically in the source category 1.A1a Public Electricity and Heat Production. The emissions from waste incineration without energy recovery is reported in source category 5.C. Waste Incineration. Additionally in Greenland open burning of waste occurs at landfill sites. Emissions associated with this are also reported under sector 5.C. Waste Incineration.

Methodological issues

The methodology used follows the IPCC Guidelines (IPCC, 2006). For waste incineration the Danish emission factors are used, as it is trusted that they are also a good representation of Greenlandic conditions.

The emission factors used for both waste incineration and open burning are included in Section 16.7.3.4.

Activity data

The amount of waste incinerated without energy recovery is presented in Table 16.7.8. The activity data is provided by the method described in Section 16.7.2.

Table 16.7.8 Activity data for waste incineration without energy recovery, Mg.

	1990	1991	1992	1993	1994	1995	1996	1997	1998	1999
Incinerated waste without energy recovery, Mg	NO	NO	NO	NO	56	225	795	1 240	2 666	2 899
<i>continued</i>	2000	2001	2002	2003	2004	2005	2006	2007	2008	2009
Incinerated waste without energy recovery, Mg	3 148	3 306	3 390	3 415	3 437	3 461	3 485	3 468	3 444	3 466
<i>continued</i>	2010	2011	2012	2013	2014	2015	2016	2017	2018	2019
Incinerated waste without energy recovery, Mg	3 486	3 488	3 501	3 523	3 550	3 548	3 557	3 592	3 616	3 628
<i>continued</i>	2020									
Incinerated waste without energy recovery, Mg	3 653									

The open burning of waste is assumed to be 80 % of the waste deposited to landfills (Survey on waste by Carl Bro, 1996 and 2001). The activity data for open burning is presented in Table 16.7.9. The activity data for open burning is provided by the method described in Section 16.7.2.

Table 16.7.9 Activity data for open burning of waste, Mg.

	1990	1991	1992	1993	1994	1995	1996	1997	1998	1999
Open burning of waste, Mg	16 567	16 714	16 808	16 956	17 140	17 236	17 033	16 922	16 101	14 941
<i>continued</i>	2000	2001	2002	2003	2004	2005	2006	2007	2008	2009
Open burning of waste, Mg	12 924	12 976	12 481	11 803	11 259	11 329	11 351	11 355	11 338	11 374
<i>continued</i>	2010	2011	2012	2013	2014	2015	2016	2017	2018	2019
Open burning of waste, Mg	11 470	11 541	11 526	11 498	11 499	11 491	11 519	11 573	11 658	11 739
<i>continued</i>	2020									
Open burning of waste, Mg	11 806									

Emission factors

Waste incineration

For waste incineration without energy recovery the same emission factors have been assumed as for waste incineration with energy recovery. The emission factors refer to the IPCC, 2006 and Danish emission factors (Nielsen et al., 2010). CO₂ emission factors have been revised recently, see chapter 3 for description. The greenhouse gas emission factors are shown in Table 16.7.10.

Table 16.7.10 Emission factors for greenhouse gases from waste incineration.

	Year	Emission factor	Unit
CO ₂	1990-2010	37.0	Kg pr GJ
CO ₂	2011	37.5	Kg pr GJ
CO ₂	2012	40.0	Kg pr GJ
CO ₂	2013-2020	42.5	Kg pr GJ
CH ₄	1990-2020	30	g pr GJ
N ₂ O	1990-2020	4	g pr GJ

The emission factors used for the indirect greenhouse gases are shown in table 16.7.11.

Table 16.7.11 Emission factors for indirect greenhouse gases from waste incineration.

	NO _x	SO ₂	NMVOC	CO	Unit
Waste incineration	134	138	0.98	7.4	g pr GJ

Open burning

For open burning emissions are calculated using the methodology, standard parameters and emission factors provided by the IPCC 2006 Guidelines.

The CH₄ emission factor used is the recommended and default is 6,500 g per tonne MSW wet weight (IPCC, 2006).

For N₂O a default emission factor of 150 g/t MSW dry weight is recommended (IPCC, 2006) this is corrected for the dry matter content to acquire an N₂O emission factor of 214 g per tonne MSW wet weight.

For calculating the CO₂ emission the dry matter content, carbon content and the fossil carbon content of the waste fractions are used. The parameters are included in Table 16.7.12.

Table 16.7.12 Parameter used in calculating CO₂ emissions from open burning.

	Dry matter content	Total carbon content, %	Fossil carbon content as percent of total carbon
Paper	0.90	46	1
Cardboard	0.90	46	1
Plastics	1.00	75	100
Organic waste	0.40	38	0
Other	0.85	3	100

Source: IPCC Guidelines 2006, Volume 5, Chapter 2, Table 2.4

An oxidation factor of 58 % is assumed for open burning (IPCC, 2006).

The emission factors for NO_x, SO₂, NMVOC and CO are presented in Table 16.7.13. The source of these emission factors are EMEP/EEA 2019 (Table 3.1).

Table 16.7.13 Emission factors for indirect greenhouse gases from open burning of waste.

	NO _x	SO ₂	NMVOC	CO	Unit
Open burning of municipal waste	3.18	0.11	1.23	55.83	Kg pr Mg

Emissions

Total emission of greenhouse gases from sector 5.C. Incineration and open burning of waste is shown in Table 16.7.14. Figure 16.7.1 shows total emission of greenhouse gases from sector 5.C. Incineration and open burning.

Table 16.7.14 Greenhouse gas emissions from incineration and open burning.

	1990	1991	1992	1993	1994	1995	1996	1997	1998	1999
CO ₂ , Gg	2.6	2.6	2.6	2.6	2.7	2.7	2.9	3.1	3.5	3.4
CH ₄ , Mg	107.7	108.6	109.3	110.2	111.4	112.1	111.0	110.4	105.5	98.0
N ₂ O, Mg	2.5	2.5	2.5	2.5	2.6	2.6	2.6	2.6	2.5	2.4
CO ₂ eqv., Gg	6.0	6.0	6.1	6.1	6.2	6.3	6.5	6.6	6.9	6.6
<i>continued</i>	2000	2001	2002	2003	2004	2005	2006	2007	2008	2009
CO ₂ , Gg	3.2	3.3	3.2	3.1	3.1	3.1	3.1	3.1	3.1	3.1
CH ₄ , Mg	85.0	85.4	82.2	77.8	74.3	74.7	74.9	74.9	74.8	75.0
N ₂ O, Mg	2.1	2.1	2.0	1.9	1.8	1.8	1.8	1.8	1.8	1.9
CO ₂ eqv., Gg	6.0	6.0	5.9	5.7	5.5	5.5	5.5	5.5	5.5	5.5
<i>continued</i>	2010	2011	2012	2013	2014	2015	2016	2017	2018	2019
CO ₂ , Gg	3.1	3.2	3.2	3.3	3.4	3.4	3.4	3.4	3.4	3.4
CH ₄ , Mg	75.7	76.1	76.0	75.8	75.9	75.8	76.0	76.4	76.9	77.4
N ₂ O, Mg	1.9	1.9	1.9	1.9	1.9	1.9	1.9	1.9	1.9	1.9
CO ₂ eqv., Gg	5.6	5.6	5.7	5.8	5.8	5.8	5.8	5.9	5.9	5.9
<i>continued</i>	2020									
CO ₂ , Gg	3.4									
CH ₄ , Mg	77.9									
N ₂ O, Mg	1.9									
CO ₂ eqv., Gg	6.0									

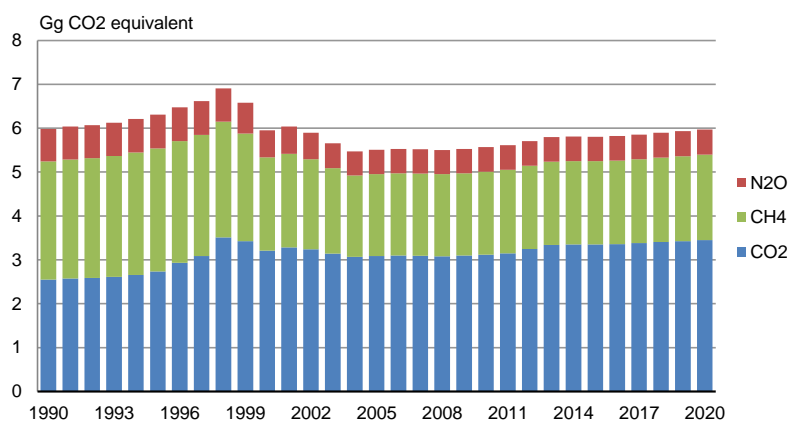

Figure 16.7.1 Emission of greenhouse gases from incineration and open burning.

The emissions of indirect greenhouse gases from incineration and open burning are shown in Table 16.7.15.

Table 16.7.15 Emission of indirect greenhouse gases from incineration and open burning, Mg.

	1990	1991	1992	1993	1994	1995	1996	1997	1998	1999
NO _x	52.7	53.1	53.5	53.9	54.6	55.1	55.3	55.6	55.0	51.6
SO ₂	1.8	1.8	1.8	1.9	2.0	2.2	3.0	3.7	5.6	5.8
NM VOC	20.4	20.6	20.7	20.9	21.1	21.2	21.0	20.8	19.8	18.4
CO	924.9	933.1	938.4	946.6	956.9	962.3	951.0	944.9	899.1	834.4
<i>continued</i>	2000	2001	2002	2003	2004	2005	2006	2007	2008	2009
NO _x	45.5	45.9	44.5	42.3	40.6	40.9	41.0	41.0	40.9	41.0
SO ₂	6.0	6.2	6.3	6.2	6.2	6.3	6.3	6.3	6.2	6.3
NM VOC	15.9	16.0	15.4	14.6	13.9	14.0	14.0	14.0	14.0	14.0
CO	721.8	724.7	697.1	659.2	628.9	632.7	634.0	634.2	633.3	635.3
<i>continued</i>	2010	2011	2012	2013	2014	2015	2016	2017	2018	2019
NO _x	41.4	41.6	41.6	41.5	41.6	41.5	41.6	41.9	42.2	42.4
SO ₂	6.3	6.3	6.3	6.4	6.4	6.4	6.4	6.5	6.5	6.5
NM VOC	14.1	14.2	14.2	14.2	14.2	14.2	14.2	14.3	14.4	14.5
CO	640.7	644.6	643.8	642.2	642.3	641.8	643.4	646.4	651.1	655.7
<i>continued</i>	2020									
NO _x	42.7									
SO ₂	6.6									
NM VOC	14.6									
CO	659.4									

16.7.4 Wastewater treatment and discharge

Source category description

In Greenland no wastewater treatment occurs; although it should be mentioned some filtering of solid residues from industry may occur and likewise there are ongoing projects focussing on septic tanks at household levels. N₂O emission from human sewage is estimated. It is assumed that no methane emission occurs.

Methodological issues

According to the IPCC Guidelines (IPCC, 2006) the important factors for CH₄ production from handling of wastewater are: wastewater characteristics; especially the quantity of degradable organic material in the wastewater, handling systems, temperature and BOD vs. COD.

The Guidelines state that production of CH₄ generally requires temperatures above 15°C, and at temperatures below this the lagoon is principally a sedimentation tank (IPCC2006). Temperatures in Greenland rarely exceed 15°C, and the monthly average temperature has not exceeded 12°C during the period 1993-2020. Therefore CH₄ is reported as Not Applicable in the CRF.

N₂O emission from wastewater handling

The IPCC default methodology only includes N₂O emissions from human sewage based on annual per capita protein intake. The methodology account for nitrogen intake (“outcome”), i.e. faeces and urine, only and neither the industrial nitrogen input nor non-consumption protein from kitchen, bath and laundry discharges are included.

Total nitrogen in the effluent discharges is calculated by the following formula from IPCC, 2006 (Equation 6.8):

$$N_{EFFLUENT} = (P \times Protein \times F_{NPR} \times F_{NON-CON} \times F_{IND-CON}) - N_{SLUDGE}$$

where P is the Greenlandic population (source: Statistics Greenland).

$Protein$ is the annual per capita protein consumption (kg/person/yr) set constant to 171.5 g/day (see text below).

F_{NPR} is the fraction of nitrogen in protein, default 0.16 kg N/kg protein (IPCC, 2006).

$F_{NON-CON}$ is the factor for non-consumed protein added to wastewater, default 1.1 (IPCC, 2006).

$F_{IND-CON}$ is the factor for industrial and commercial co-discharged protein into the sewer system, default 1.25 (IPCC, 2006).

N_{SLUDGE} is nitrogen removed with sludge, default zero kg N/yr.

Thus, total N₂O emission from effluent discharges is calculated by the formula:

$$N_2O_{EFFLUENT} = N_{EFFLUENT} \times EF_{N_2O-N} \times \frac{44}{28}$$

The default IPCC emission factor for N₂O emissions from domestic wastewater nitrogen effluent is 0.005 kg N₂O-N/kg N. This emission factor is based on limited field data and on specific assumptions regarding the occurrence of nitrification and denitrification in rivers and in estuaries. To convert total N in effluents to emissions in N₂O the mass ratio 44/28 is used.

For households

A large part of the diet originates from seafood, fish or sea mammals, but imported fabricated foods are expected to continue to take over an increasing part of human energy consumption. Due to weather conditions most of fresh food comes from wild animals or fish. Greenland has a production of lamb and a limited supply of vegetables; still most of the produced foods are imported from outside (Mulvad et al., 2007).

In Greenland, the traditional diet based on meat and fish has undergone diversification towards more carbohydrates with the development of a monetary economy; in 1855 the protein content of a mean diet was 377 g protein, whereas 80 years later, in 1935 - 43, the protein content of a mean diet was 257 g protein (Périssé and François, 1981). Today, the majority of young urbanised Greenlandic Inuit have Western dietary habits and consume less meat from marine mammals, terrestrial mammals and birds than Inuit from the hunting districts; Dietary profiles of Canadian Baffin Island Inuit with a high consumption of traditional foods have shown a mean daily protein intake of 144-199 g/day in 41- to 61-year-old (Laursen et al, 2001).

As no data on the protein intake are available a protein intake of 171.5 g/day, i.e. the average of the Canadian Inuit were adopted, as it is assumed that the protein intake has declined even more since 1935 due to increased number of urbanised Greenlandic Inuit. For comparison the Danish yearly protein consumption according to FAOSTAT has increased from 98 g/day in 1990 to 112 g/day in 2005. Using this number, the yearly protein intakes may be derived by multiplying with the population number and days in a year. Based on the above it was decided to set the protein intake to the average value of the Canadian Inuit data, 171.5 g/day. The N-content in effluent wastewater in Greenland was calculated the equation shown above.

From industries

The production of residue products from the fish industry in Greenland amounts to around 14,000 tonnes per year (Nielsen et al., 2005). Overall the waste amount from the Greenland halibut production is around 40 %, while the waste amount from codfish production is 50 %; this governs only the fish production including pre-processing.

According to IPCC, the fraction of nitrogen in protein is 0.16 (IPCC, 2006). The IPCC reports a range of 0.3 to 3.1 kg total N/tonne fish referring to effluent loads from cod filleting; i.e. 0.0031. The report also presents values of the total N content of untreated wastewater from the fish industry in the range of 400-1000 mg/l corresponding to a fraction of corresponding. However, as it was not possible to find data for all fish groups, and as it was not possible to determine that fraction of fish, which was pre-processed and how big a fraction that was sold without pre-processing, the below approach was adopted.

From the EC BAT note (EC, 2003) the total N-content of untreated wastewater from the fishing industry was reported to be between 400 and 1000 mg/L with an average value of 700 mg/L. The number was multiplied by the water used within the fishing industry reported for 2004 to 2020 by Statistics Greenland. The effluent N-content for 1990 to 2002 was set equal to the estimated value for 2003.

Emissions

Emission of N₂O from wastewater discharges is shown in Table 16.7.16.

Table 16.7.16 N₂O emissions in wastewater from households and industries 1990-2020.

	1990	1991	1992	1993	1994	1995	1996	1997	1998	1999
N ₂ O emission, effluents households, Gg	0.005	0.005	0.005	0.005	0.005	0.005	0.005	0.005	0.005	0.005
N ₂ O emission, effluents industries, Gg	0.019	0.019	0.019	0.019	0.019	0.019	0.019	0.019	0.019	0.019
N ₂ O emission, effluents sum, Gg	0.024	0.024	0.024	0.024	0.024	0.024	0.024	0.024	0.024	0.024
<i>continued</i>	2000	2001	2002	2003	2004	2005	2006	2007	2008	2009
N ₂ O emission, effluents households, Gg	0.005	0.005	0.005	0.005	0.005	0.005	0.005	0.005	0.005	0.005
N ₂ O emission, effluents industries, Gg	0.019	0.019	0.019	0.019	0.019	0.019	0.019	0.020	0.021	0.016
N ₂ O emission, effluents sum, Gg	0.024	0.024	0.024	0.024	0.024	0.024	0.024	0.024	0.025	0.021
<i>continued</i>	2010	2011	2012	2013	2014	2015	2016	2017	2018	2019
N ₂ O emission, effluents households, Gg	0.005	0.005	0.005	0.005	0.005	0.005	0.005	0.005	0.005	0.005
N ₂ O emission, effluents industries, Gg	0.015	0.016	0.014	0.010	0.010	0.009	0.011	0.011	0.012	0.012
N ₂ O emission, effluents sum, Gg	0.020	0.020	0.019	0.015	0.015	0.014	0.016	0.016	0.017	0.017
<i>continued</i>	2020									
N ₂ O emission, effluents households, Gg	0.005									
N ₂ O emission, effluents industries, Gg	0.013									
N ₂ O emission, effluents sum, Gg	0.018									

Total emission of N₂O increased slightly until 2008 due to an increase in the emission from industrial effluents. However, since 2009 total emission of N₂O has decreased to a total level of 0.015-0.020 Gg (which is lower than 1990) due to a temporarily decrease in industrial effluents primarily caused by a decrease in the catches of shrimps.

16.7.5 Uncertainties

A tier 1 uncertainty assessment has been carried out in accordance with the IPCC Guidelines (IPCC, 2006). The uncertainty has been estimated for all sources included in the reporting for the waste sector. The uncertainties for the activity data and emission factors are shown in Table 16.7.17.

Table 16.7.17 Uncertainties for activity data and emission factors for the waste sector.

Subsector	Pollutant	Activity data uncertainty	Emission factor uncertainty
5C Waste incineration	CO ₂	10	25
5A Solid Waste Disposals sites	CH ₄	10	100
5C Waste incineration	CH ₄	10	50
5D Wastewater Handling	N ₂ O	30	100
5C Waste incineration	N ₂ O	10	100

The amount of waste incinerated and open burned is relatively well known and the uncertainty is set to 10 %. The same is the case for the waste deposited to landfills. For waste water handling an uncertainty of 30 % on the activity data has been assumed.

Regarding the emission factor uncertainty, a value of 100 % has been used for CH₄ from solid waste disposal, N₂O from wastewater treatment and N₂O from waste incineration. This is in the same range as recommended by the IPCC Guidelines (IPCC, 2000). For CO₂ and CH₄ from waste incineration emission factor uncertainties of 25 % and 50 % respectively have been chosen.

The resulting uncertainties for the individual greenhouse gases and the total uncertainty on the greenhouse gas emission are shown in Table 16.7.18.

Table 16.7.18 Uncertainties for the emission estimates.

	Uncertainty %	Trend 1990-2020 %	Trend uncertainty %
GHG	± 46	-9.8	± 15.7
CO ₂	± 27	35.2	± 19.1
CH ₄	± 73	-7.7	± 13.0
N ₂ O	± 95	-26.2	± 28.2

16.7.6 Source specific QA/QC

The elaboration of a formal QA/QC plan is to be completed.

However, data on solid waste disposal, waste water handling and waste incineration has gone through a great deal of quality work with regard to accuracy, comparability and completeness.

All external data used for the emission inventory submission are archived in spreadsheets. Data are archived annually in order to ensure that the basic data for a given report are always available in their original form.

Annual data on solid waste disposal, waste water handling and waste incineration are compared with previous years and large discrepancies are checked.

Safely stored and quality checked activity data are then processed by using a methodological approach consistent with international guidelines.

Calculated emission factors are compared with guideline emission factors to ensure that they are reasonable. The calculations follow the principle in international guidelines.

During data processing, it is checked that calculations are being carried out correctly.

Time series for activity data, emission factors and calculated emissions are used to identify possible errors in the calculation procedure. In fact, during the calculation, numerous controls take place to ensure correctness. Sums are checked in the various stages in the calculation procedure. Implied emission factors are compared to emission factors.

Every single time series imported to the CRF Reporter is checked for annual activity, units for activity, emission factor and emissions. Additional checks are performed on the database. The database encloses every single activity data, emission factors, emission, notation key and comment imported to the CRF Reporter.

16.7.7 Source specific recalculations and improvements

In this 2022 submission there has been minor revisions in the waste sector. These revisions are caused by the fact that DOC-values have been revised according to IPCC 2006, CO₂ emission factors for the fossil fuel part of municipal waste has also been revised according to Table 16.7.10.

Table 16.8.19 shows recalculations in the waste sector compared to the 2021 submission. Minor changes occur.

Table 16.8.19 Changes in GHG emission in the waste sector compared to the 2021 submission.

	1990	1991	1992	1993	1994	1995	1996	1997	1998	1999
Previous inventory, Gg CO ₂ eqv.	17.5	17.6	17.7	17.8	18.0	18.2	18.4	18.6	19.0	18.7
Recalculated, Gg CO ₂ eqv.	17.7	17.8	17.9	18.0	18.2	18.4	18.6	18.9	19.2	18.9
Change in Gg CO ₂ eqv.	0.2	0.2	0.2	0.2	0.2	0.2	0.2	0.2	0.3	0.3
Change in pct.	1.3	1.3	1.3	1.3	1.3	1.3	1.3	1.3	1.3	1.4
<i>continued</i>	2000	2001	2002	2003	2004	2005	2006	2007	2008	2009
Previous inventory, Gg CO ₂ eqv.	18.1	18.1	18.0	17.7	17.5	17.5	17.5	17.6	17.8	16.5
Recalculated, Gg CO ₂ eqv.	18.3	18.4	18.2	18.0	17.8	17.8	17.8	17.8	18.1	16.7
Change in Gg CO ₂ eqv.	0.3	0.3	0.3	0.3	0.2	0.2	0.2	0.2	0.2	0.2
Change in pct.	1.4	1.4	1.4	1.4	1.4	1.4	1.4	1.4	1.4	1.5
<i>continued</i>	2010	2011	2012	2013	2014	2015	2016	2017	2018	2019
Previous inventory, Gg CO ₂ eqv.	16.2	16.3	15.9	14.7	14.6	14.4	14.9	15.0	15.1	15.3
Recalculated, Gg CO ₂ eqv.	16.5	16.6	16.2	15.2	15.0	14.8	15.4	15.4	15.6	15.7
Change in Gg CO ₂ eqv.	0.2	0.3	0.3	0.4	0.4	0.4	0.4	0.4	0.5	0.4
Change in pct.	1.5	1.6	2.2	3.0	3.0	3.0	2.9	2.8	3.2	2.8
<i>continued</i>	2020									
Previous inventory, Gg CO ₂ eqv.	-									
Recalculated, Gg CO ₂ eqv.	16.0									
Change in Gg CO ₂ eqv.	-									
Change in pct.	-									

16.7.8 Source specific planned improvements

Some planned improvements to the emission inventories are discussed below.

1) Improved data on solid waste disposals

In future inventories attempts will be made in order to improve data on solid waste disposals in general. Statistics Greenland has encouraged the municipal technical departments with responsibility for waste handling to start gathering data on the yearly amounts of waste handled.

2) Improved data on waste water handling

In future inventories attempts will be made in order to improve data on waste water handling in general. However, at the moment the municipal technical departments seem to have no data on waste water handling at all.

16.7.9 References

EC, 2003: Reference Document on BAT in the food, drink and milk industry. Available at:
<http://gasunie.eldoc.ub.rug.nl/FILES/root/2003/2665985/2665985.pdf>

EEA, 2019: EMEP/EEA air pollutant emission inventory guidebook 2019. Technical guidance to prepare national emission inventories. EEA Report 13/2019. Available at:
<https://www.eea.europa.eu/publications/emep-eea-guidebook-2019>
 (07-02-2021).

IPCC, 1997: Revised 1996 IPCC Guidelines for National Greenhouse Gas Inventories. Available at:
<http://www.ipcc-nggip.iges.or.jp/public/gl/invs1.html>

IPCC, 2000: Penman, J., Kruger, D., Galbally, I., Hiraishi, T., Nyenzi, B., Emmanuel, S., Buendia, L., Hoppaus, R., Martinsen, T., Meijer, J., Miwa, K. & Tanabe, K. (Eds). Good Practice Guidance and Uncertainty Management in National Greenhouse Gas Inventories. Published: IPCC/OECD/IEA/IGES, Hayama, Japan. Available at:

<http://www.ipcc-nggip.iges.or.jp/public/gp/english/> (15-04-2007).

IPCC, 2006: 2006 IPCC Guidelines for National Greenhouse Gas Inventories, Prepared by the National Greenhouse Gas Inventories Programme, Eggleston H.S., Buendia L., Miwa K., Ngara T. & Tanabe K. (eds). Published: IGES, Japan. Available at:

<http://www.ipcc-nggip.iges.or.jp/public/2006gl/index.html> (21-02-2014).

Laursen, J., Milman, N., Pedersen, H.S., Mulvad, G., Saaby, H. and Byg, K.-E., 2001: Elements in autopsy liver tissue samples from Greenlandic Inuit and Danes. III. Zinc measured by X-ray fluorescence spectrometry. *Journal of Trace Elements in Medicine and Biology*, 15:209-214.

Mulvad, G., Petersen, H.S. and Olsen, J., 2007: Arctic health problems and environmental challenges in Greenland. In: Ørbæk, J.B., Kallenborn, R., Tombre, I., Hegseth, E.N., Falk-Petersen, S. and Hoel, A.H. *Arctic Alpine Ecosystems and People in a Changing Environment*. Available at:

<http://www.springerlink.com/content/tu377x6715200027/fulltext.pdf>

Nielsen M., Nielsen, O.-K. & Thomsen, M. 2010: Emissions from decentralised CHP plants 2007 - Energinet.dk Environmental project no. 07/1882. Project report 5 - Emission factors and emission inventory for decentralised CHP production. National Environmental Research Institute, Aarhus University. 113 pp. - NERI Technical report No. 786. Available at:

<http://www.dmu.dk/Pub/FR786.pdf> (2011-02-28).

Nielsen, O.-K., Plejdrup, M.S., Winther, M., Nielsen, M., Gyldenkerne, S., Mikkelsen, M.H., Albrektsen, R., Thomsen, M., Hjelgaard, K., Fauser, P., Bruun, H.G., Johannsen, V.K., Nord-Larsen, T., Vesterdal, L., Stupak, I., Scott-Bentsen, N., Rasmussen, E., Petersen, S.B., Olsen, T.M. & Hansen, M.G. 2021. Denmark's National Inventory Report 2021. Emission Inventories 1990-2019 - Submitted under the United Nations Framework Convention on Climate Change and the Kyoto Protocol. 944 pp. - Scientific Report from DCE - Danish Center for Environment and Energy no. 437. Available at:

<https://dce2.au.dk/pub/SR437.pdf>

Nielsen, U., Nielsen, K., Mai, P., Frederiksen, O., 2006: Organisk industriaffald i Grønland - Værktøjer til fremme af bedste tilgængelige teknik og nyttiggørelse af restprodukter nr. M. 127/001-0164. Realistiske muligheder for nyttiggørelse/udnyttelse af organisk industriaffald i Grønland. (In Danish)

Périssé, J. and François, P., 1981: Variability of the protein-calorie ratio in diets. *FAO/WHO/UNUEPR/81/40*. Available at:

<http://www.fao.org/docrep/MEETING/004/AA054E/AA054E00.htm>

Statistics Greenland, 2020: Statistics on Population 1960-2020. Available at:

<http://bank.stat.gl/BEEST3>

US EPA, 1992: AP 42, Fifth Edition, Volume I Chapter 2.5: Open burning. Available at: <http://www.epa.gov/ttn/chief/ap42/ch02/final/c02s05.pdf>

US EPA, 2001: US-EPA Emission Inventory Improvement Program. Volume III Chapter 16 Open Burning. United States Environmental Protection Agency (USEPA). Available at: http://www.epa.gov/ttn/chief/eiip/techreport/volume03/iii16_apr2001.pdf

16.8 Other

In CRF Sector 7, there are no activities and emissions or removals for the inventory of Greenland.

16.9 Recalculations and improvements

The 2022 submission is the twelfth year where Greenland on the request of the ERT submits a full CRF.

For recalculations and improvements please refer to Sections 16.3 - 16.7 and Section 16.10.

16.10 KP-LULUCF

Greenland does not have a commitment in the second commitment period and therefore is not accounting for KP-LULUCF activities. However, the reporting is still done as Greenland continues to be part of the Kyoto Protocol.

The KP-LULUCF emission estimates are made in accordance with the Revised Supplementary Methods and Good Practice Guidance Arising from the Kyoto Protocol (IPCC 2014) and the 2006 IPCC guidelines.

16.10.1 General information

In the following text, the abbreviations used are in accordance with definitions in the IPCC guidelines:

A:	Afforestation
R:	Reforestation
D:	Deforestation
FF:	Forest remaining Forest, areas remaining forest after 1990
FL:	Forest Land meeting the Danish definition of forests
CL:	Cropland
GL:	Grassland
SE:	Settlements
OL:	Other land, unclassified land
FM:	Forest Management, areas managed under article 3.4
CM:	Cropland Management, areas managed under article 3.4
GM:	Grazing land Management, areas managed under article 3.4
RE:	Revegetation
WDR:	Wetland Drainage and Rewetting

Definition of forest and any other criteria

For the estimation of anthropogenic emissions by sources and removals by sinks associated with afforestation (A), reforestation (R) and deforestation (D) since 1990 under Article 3.3 and forest management (FM) under Article 3.4 of the Kyoto Protocol, the following forest definition will be applied:

- Minimum values for tree crown cover: 10 % tree crown cover for forests.

- Minimum values for land area: 0.5 ha.
- Minimum value for tree height: trees must be able to reach a minimum height of 5 m in the site.

In addition, the forest area includes temporarily unstocked areas, smaller open areas in the forest needed for management purposes and fire breaks. Forests in national parks, reserves or areas under special protection are included. Windbreaks and groves covering more than 0.5 ha and with a minimum width of 20 m are also considered as forests.

Woody biomass does not exist outside the forest and hence not reported under Cropland and Grassland.

Elected activities under Article 3, paragraph 4, of the Kyoto Protocol

As regards the possibility of including in the first commitment period emissions and removals associated with land use, land-use change and forestry activities under Article 3.4 of the Kyoto Protocol, it has been decided to include emissions and removals from forest management (FM), cropland management (CM) and grazing land management (GM).

The national system has identified land areas associated with the activities under Article 3.4 of the Kyoto Protocol in accordance with definitions, modalities, rules and guidelines relating to land use, land-use change and forestry activities under the protocol by satellite monitoring, use of Greenlandic agricultural subsidiary system and forest information.

Inventories of emissions and removals under Article 3.3 and Article 3.4 are prepared and reported annually together with the other greenhouse gas inventory information.

Description of how the definitions of each activity under Article 3.3 and each elected activity under Article 3.4 have been implemented and applied consistently over time

The definition of afforestation, reforestation and deforestation is in accordance with the IPCC 2006 and the Revised Supplementary Methods and Good Practice Guidance Arising from the Kyoto Protocol (IPCC 2014).

Afforestation or reforestation is identified when areas have wooded tree cover and fulfil the forest definition given above. The time of the AF is given by the time of action, i.e. planting of trees. No deforestation and reforestation is reported for Greenland as this is not occurring. All types of establishment of forest (AF or RF) are considered human induced.

As for the forest management (Article 3.4), the forest areas fulfilling the definition given above are included under this activity. All forest areas are considered managed except for the remote Qinnua-valley.

For Cropland and Grassland the area accounted for under Art. 3.4 have been estimated with the best knowledge from the Greenlandic Agricultural Consulting Services. As the agriculture in Greenland is economically subsidized the area is estimated with a high accuracy. Only areas that are reported as CL and GL are included in the accounted area.

Description of precedence conditions and/or hierarchy among article 3.4 activities and how they have been consistently applied in determining how land was classified

All Forest activities have precedence, after this Cropland activities and then Grassland activities.

Afforestation has precedence. All land converted to forest are included as afforested area. Deforested areas are not reported as this is not occurring. The following categories in the Convention reporting are included under afforestation:

- 4A25 OL to A

FM activities are only related to:

- 4A1 Forest remaining Forest

CM activities are related to:

- 4B22 GL to CL

GM activities area related to:

- 4C1 GL remaining GL

No elected land has left land that is not accounted for. Land conversion between elected activities (FM, CM and GM) has been allowed but is currently not occurring. No land elected under article 3.4 activities has been converted to Other Land. Other land converted to elected activities is included in the respective category. As the small increase in CL is made on elected GL areas the total reported area under CL and GL under article 3.4 is constant.

16.10.2 Spatial assessment unit used for determining the areas of the units of land under Article 3.3

Afforestation and reforestation are identified as areas which not were covered by forest in 1990. The increase in the forest area is planted.

Methodology used to develop the land transition matrix

The land use matrix is based on the best available data. No vector maps exist of the individual forests, cropland and grassland.

Maps and/or database to identify the geographical locations, and the system of identification codes for the geographical locations

The forests have been given individual names. For the Cropland and Grassland area no identification has been made.

16.10.3 Afforestation, Reforestation & Deforestation (ARD)

Methods for carbon stock change and GHG emission and removal estimates

For afforestation the carbon stock change in the period 1990 - 2014 is based both on the area of afforestation and the information on species composition.

Description of the methodologies and the underlying assumptions used

See Chapter 16.6.

Justification when omitting any carbon pool or GHG emissions/removals from ARD

C stock changes in the soil are not expected due to the cold climate to occur and hence following the guidelines for a Tier 1 approach. As the afforestation is made by hand planting no damages of the existing soil C is expected to take place.

Information on whether or not indirect and natural GHG emissions and removals have been factored out

No factoring out has been performed in the emission and removal estimates.

Changes in data and methods since the previous submission (recalculations)

No recalculation has been performed.

Uncertainty estimates

Not given in the current reporting.

Information on other methodological issues

See Chapter 16.6.

The year of the onset of an activity, if after 2008

Not applicable.

16.10.4 Forest Management (FM)

Methods for carbon stock change and GHG emission and removal estimates

See Chapter 16.6 in LULUCF on "Forest remaining forest (4.A.1)".

Methodologies and the underlying assumptions

See Chapter 16.6 in LULUCF on "Forest remaining forest (4.A.1)".

Omission of pools from FM

C changes in forest soils are omitted and hereby following IPCC 2006 guidelines at a Tier 1 level and the Revised Supplementary Methods and Good Practice Guidance Arising from the Kyoto Protocol (IPCC 2014).

Factoring out

No factoring out has been performed.

Recalculations

No recalculation has been performed.

Uncertainty estimates

See Table 16.11.2

Information on other methodological issues

See Chapter 16.7 in LULUCF on "Forest remaining forest (4.A.1)".

The year of the onset of an activity, if after 2008

Not applicable.

16.10.5 Cropland Management (CM)

Methods for carbon stock change and GHG emission and removal estimates

Methodologies and the underlying assumptions used

The area with agricultural CM is reported as the area given in Statistics Greenland.

The same methodology as used in the Convention reporting is used in the KP reporting.

Omission of pool from CM

Aboveground and belowground living biomass, litter and dead organic are only reported for perennial woody crops in accordance with IPCC 2006 guidelines. No litter and dead organic matter are reported under CM as these are not occurring. Therefore only aboveground living biomasses are reported under CM. Below-ground biomass is included in above-ground biomass.

Factoring out

No factoring out has been made.

Recalculations

None.

Uncertainty estimates

See Table 16.10.1.

Information on other methodological issues

None.

The year of the onset of an activity, if after 2008

Not applicable.

16.10.6 Grazing land management (GM)

Methods for carbon stock change and GHG emission and removal estimates

Grazing land is defined as land improved grassland and unmanaged grassland.

Description of the methodologies and the underlying assumptions used

The major part of the grassland is unmanaged (241,000 hectare). Only 1078 hectares is improved grassland with occasional reseeding and fertiliser application. The methodology used is the default Tier 1. This is in accordance with IPCC 2006 guidelines as the total emission from LULUCF consists of less than 0.2 % of the total emission from Greenland.

Omission of pools from GM

Aboveground and belowground living biomass, litter and dead organic are only reported for perennial woody crops in accordance with IPCC 2006 guidelines. No litter and dead organic matter are reported under GM as these are not occurring. Therefore, only aboveground living biomasses are reported under GM. Below-ground biomass is included in above-ground biomass.

Factoring out

No factoring out has been made.

Recalculations

No recalculation has been performed.

Uncertainty estimates

See Table 16.11.2.

Information on other methodological issues

None.

The year of the onset of an activity, if after 2008

Not applicable.

16.10.7 Revegetation

Not elected.

16.10.8 Wetland drainage and rewetting

Not elected.

16.10.9 Article 3.3**Information that demonstrates that activities under Article 3.3 began on or after 1 January 1990 and before 31 December 2012 and are direct human-induced**

All forests in Greenland are planted except for the Qinnua valley, which is in a remote area.

Information on how harvesting or forest disturbance that is followed by the reestablishment of forest is distinguished from deforestation

No deforestation is occurring and therefore not applicable.

Information on the size and geographical location of forest areas that have lost forest cover but which are not yet classified as deforested

Not applicable.

16.10.10 Article 3.4**Information that demonstrates that activities under Article 3.4 have occurred since 1 January 1990 and are human-induced****Forest Management**

In Forest Management, all forest areas are under management and changes in carbon stock are hence seen as human induced.

Cropland Management

Due to the cold climate and the recent increase in temperature, it has only very recently been possible to grow agricultural crops in Greenland with the first fields established around 2001. Today it is estimated that 10.5 hectares are regularly ploughed.

Grassland Management

Due to the cold climate in Greenland and the recent increase in temperature, it has only recently been valuable to introduce management activities in the grassland to increase the crop yield. This is well documented in the Greenlandic subsidiary system to the farmers.

Information relating to Cropland Management, Grazing Land Management and Revegetation, if elected, for the base year

No further information is available.

Information relating to Forest Management

No further information is available.

16.10.11 Other information

Key category analysis for Article 3.3 activities and any elected activities under Article 3.4

According to the IPCC Good Practice Guidance for LULUCF a category that is identified as key in the UNFCCC inventory should also be considered key under the Kyoto Protocol (IPCC, 2014).

No LULUCF categories are reported as a key source. The total emission from the LULUCF sector is only 0.2 % of the total emission from Greenland.

16.10.12 Information relating to Article 6

There are no Article 6 projects (Joint Implementation) on the Greenlandic territory.

16.10.13 Literature

IPCC 2014, 2013 Revised Supplementary Methods and Good Practice Guidance Arising from the Kyoto Protocol, Hiraishi, T., Krug, T., Tanabe, K., Srivastava, N., Baasansuren, J., Fukuda, M. and Troxler, T.G. (eds). Published: IPCC, Switzerland.

16.11 Annex 1 Key categories

A Key Category Analysis (KCA) for year 1990 and 2020 for Greenland has been carried out in accordance with the IPCC Good Practice Guidance. For 1990 a level KCA has been carried out.

The base year in the analysis is the year 1990 for the greenhouse gases CO₂, CH₄, N₂O and 1995 for the greenhouse F-gases HFC, PFC and SF₆. The KCA approach is a Tier 1 quantitative analysis.

The level assessment of the Tier 1 KCA is a ranking of the source categories in accordance to their relative contribution to the national total of greenhouse gases calculated in CO₂ equivalents. The level key categories are found from the list of source categories ranked according to their contribution in descending order. Level key categories are those from the top of the list and of which the sum constitutes 95 % of the national total.

The trend assessment of the Tier 1 KCA is a ranking of the source categories according to their contribution to the trend of the national total of greenhouse gases, calculated in CO₂ equivalents, from the base year to the year under consideration. The trend of the source category is calculated relative to that of the national totals and the trend is then weighted with the contribution, according to the level assessment. The ranking is in descending order. As for the level assessment, the cut-off point for the sum of contribution to the trend is 95 % and the source categories from the top of the list to the cut-off line are trend key categories.

Result of the Key Category Analysis for Greenland for the year 1990 and 2020

The entries in the results of KCA in Tables 16.11.1 to 16.11.3 for the years 1990 and 2020 are composed from CRFs for those years in this report. Note that base-year estimates are not used in the level assessment analysis for

year 2020, but are only included in Table 16.11.2 to make it more uniform with Tables 16.11.1 and 16.11.3.

The result of the Tier 1 KCA level assessment for Greenland for 1990 is shown in Table 16.11.1. For the assessment, five categories were identified as key categories and marked as shaded, see Table 16.11.1.

The result of the Tier 1 KCA level assessment for Greenland for 2020 is shown in Table 16.11.2. For the assessment, seven categories were identified as key categories, see Table 16.11.2.

The result of the Tier 1 KCA trend assessment for Greenland for 1990/1995-2020 is shown in Table 16.11.3. For the trend assessment, nine categories were identified as key categories, see Table 16.11.3. Note that according to the GPG, the analysis implies that contributions to the trend are all calculated as mathematically positive to be able to perform the ranking. LULUCF activities are in the table included with their sign, i.e. emissions: +, removals: -.

In Table 16.11.4 a summary of Key Category Analysis for Greenland is given for level assessment for year 1990/95 and 2020 and for trend for years 1990-2020. All the categories are listed by sector and key sources are shown with their ranking.

Table 16.11.1 Key Category Analysis base year 1990/1995, level assessment, Tier 1.

Table 7.A1 (of Good Practice Guidance) Tier 1 Analysis - Level Assessment GRL – inventory

A			B	C	D	E
IPCC Source Categories (LULUCF included)			Direct GHG	Base Year Estimate	Base Year Level Assessment	Base year Cumulative total of Col. D
				Ex,o Gg CO ₂ eqv.	Lx,o	
Energy	Combustion excluding transport	Liquid fuels	CO ₂	523.872	0.802	0.802
Energy	Domestic aviation		CO ₂	38.709	0.059	0.861
Energy	Road transportation		CO ₂	36.423	0.056	0.917
Energy	Domestic navigation		CO ₂	20.941	0.032	0.949
Agriculture	Enteric fermentation		CH ₄	7.627	0.012	0.961
Waste	Wastewater treatment and discharge		N ₂ O	7.154	0.011	0.972
Waste	Solid waste disposal		CH ₄	4.551	0.007	0.979
Waste	Incineration and open burning of waste		CH ₄	2.692	0.004	0.983
Waste	Incineration and open burning of waste		CO ₂	2.551	0.004	0.987
Energy	Combustion excluding transport	Other fuels	CO ₂	1.675	0.003	0.989
Energy	Combustion excluding transport		N ₂ O	1.339	0.002	0.991
Energy	Combustion excluding transport		CH ₄	1.133	0.002	0.993
Agriculture	Manure management		N ₂ O	0.869	0.001	0.994
Agriculture	Agricultural soils		N ₂ O	0.857	0.001	0.996
Waste	Incineration and open burning of waste		N ₂ O	0.741	0.001	0.997
Energy	Road transportation		N ₂ O	0.627	0.001	0.998
Energy	Domestic aviation		N ₂ O	0.323	0.000	0.998
Industry	Solvent use		CO ₂	0.263	0.000	0.999
Industry	Paraffin wax use		CO ₂	0.251	0.000	0.999
LULUCF	Grassland remaining grassland		CO ₂	0.206	0.000	0.999
Agriculture	Manure management		CH ₄	0.186	0.000	1.000
Energy	Road transportation		CH ₄	0.068	0.000	1.000
LULUCF	Forest land		N ₂ O	0.052	0.000	1.000
Energy	Domestic navigation		N ₂ O	0.051	0.000	1.000
Energy	Domestic navigation		CH ₄	0.036	0.000	1.000
Industry	Emission of SF ₆		SF ₆	0.034	0.000	1.000
Industry	Emission of HFC's		HFCs	0.033	0.000	1.000
Agriculture	Liming		CO ₂	0.008	0.000	1.000
Energy	Domestic aviation		CH ₄	0.007	0.000	1.000
LULUCF	Grassland		CO ₂	0.004	0.000	1.000
Industry	Paraffin wax use		N ₂ O	0.001	0.000	1.000
Industry	Paraffin wax use		CH ₄	0.000	0.000	1.000
LULUCF	Forest land		CH ₄	0.000	0.000	1.000
Industry	Road paving with asphalt		CO ₂	0.000	0.000	1.000
Industry	Road paving with asphalt		CH ₄	0.000	0.000	1.000
Industry	Asphalt roofing		CO ₂	0.000	0.000	1.000
Industry	Limestone and dolomite use		CO ₂	0.000	0.000	1.000
LULUCF	Forest land remaining forest land		CO ₂	0.000	0.000	1.000
LULUCF	Land converted to cropland		CO ₂	0.000	0.000	1.000
Total				653.283	1.000	

Table 16.11.2 Key Category Analysis year 2020, level assessment, Tier 1.

Table 7.A1 (of Good Practice Guidance) Tier 1 Analysis - Level Assessment GRL – inventory

A			B	C	D	E	F
IPCC Source Categories (LULUCF included)			Direct GHG	Base Year Estimate Ex,o Gg CO ₂ eqv	Year 2020 Estimate Ex,t Gg CO ₂ eqv	Year 2020 Level Assessment Lx,t	Year 2020 Cumulative total of Col. E
Energy	Combustion excluding transport	Liquid fuels	CO ₂	523.872	431.820	0.749	0.749
Energy	Road transportation		CO ₂	36.423	38.984	0.068	0.816
Energy	Domestic aviation		CO ₂	38.709	27.036	0.047	0.863
Energy	Domestic navigation		CO ₂	20.941	25.922	0.045	0.908
Industry	Emission of HFC's		HFCs	0.033	12.910	0.022	0.930
Energy	Combustion excluding transport	Other fuels	CO ₂	1.675	9.152	0.016	0.946
Agriculture	Enteric fermentation		CH ₄	7.627	6.274	0.011	0.957
Waste	Wastewater treatment and discharge		N ₂ O	7.154	5.250	0.009	0.966
Waste	Solid waste disposal		CH ₄	4.551	4.736	0.008	0.974
Waste	Incineration and open burning of waste		CO ₂	2.551	3.448	0.006	0.980
Waste	Incineration and open burning of waste		CH ₄	2.692	1.947	0.003	0.984
Agriculture	Agricultural soils		N ₂ O	0.857	1.712	0.003	0.987
Energy	Combustion excluding transport		N ₂ O	1.339	1.316	0.002	0.989
LULUCF	Grassland remaining grassland		CO ₂	0.206	1.292	0.002	0.991
Energy	Combustion excluding transport		CH ₄	1.133	1.085	0.002	0.993
Energy	Road transportation		N ₂ O	0.627	0.895	0.002	0.995
Agriculture	Manure management		N ₂ O	0.869	0.770	0.001	0.996
Waste	Incineration and open burning of waste		N ₂ O	0.741	0.573	0.001	0.997
Industry	Paraffin wax use		CO ₂	0.251	0.419	0.001	0.998
Industry	Solvent use		CO ₂	0.263	0.325	0.001	0.998
Energy	Domestic aviation		N ₂ O	0.323	0.225	0.000	0.999
Energy	Road transportation		CH ₄	0.068	0.166	0.000	0.999
Agriculture	Manure management		CH ₄	0.186	0.152	0.000	0.999
Industry	Limestone and dolomite use		CO ₂	0.000	0.110	0.000	0.999
LULUCF	Forest land remaining forest land		CO ₂	0.000	-0.066	0.000	1.000
Energy	Domestic navigation		N ₂ O	0.051	0.065	0.000	1.000
LULUCF	Forest land		N ₂ O	0.052	0.055	0.000	1.000
LULUCF	Land converted to cropland		CO ₂	0.000	0.048	0.000	1.000
Energy	Domestic navigation		CH ₄	0.036	0.045	0.000	1.000
LULUCF	Grassland		CO ₂	0.004	0.010	0.000	1.000
Energy	Domestic aviation		CH ₄	0.007	0.005	0.000	1.000
Agriculture	Liming		CO ₂	0.008	0.004	0.000	1.000
Industry	Emission of SF ₆		SF ₆	0.034	0.003	0.000	1.000
Industry	Paraffin wax use		N ₂ O	0.001	0.001	0.000	1.000
Industry	Paraffin wax use		CH ₄	0.000	0.000	0.000	1.000
Industry	Road paving with asphalt		CO ₂	0.000	0.000	0.000	1.000
LULUCF	Forest land		CH ₄	0.000	0.000	0.000	1.000
Industry	Road paving with asphalt		CH ₄	0.000	0.000	0.000	1.000
Industry	Asphalt roofing		CO ₂	0.000	0.000	0.000	1.000
Total				653.283	576.690	1.000	

Table 16.11.3 Key Category Analysis years 1990/1995-2020, trend assessment, Tier 1.

Table 7.A1 (of Good Practice Guidance) Tier 1 Analysis - Trend Assessment GRL – inventory

A			B	C	D	E	F	G
IPCC Source Categories (LULUCF included)			Direct GHG	Base Year Estimate	Year 2020 Estimate	Trend Assessment	Contribution To	Cumul. total of Col. F
				Ex,o Gg CO ₂ - eq	Ex,t Gg CO ₂ - eq	Tx,t	Trend	
Energy	Combustion excluding transport	Liquid fuels	CO ₂	523.872	431.820	0.047	0.383	0.383
Industry	Emission of HFC's		HFCs	0.033	12.910	0.020	0.161	0.544
Energy	Combustion excluding transport,	Other fuels	CO ₂	1.675	9.152	0.012	0.096	0.640
Energy	Domestic navigation		CO ₂	20.941	25.922	0.011	0.093	0.733
Energy	Domestic aviation		CO ₂	38.709	27.036	0.011	0.089	0.823
Energy	Road transportation		CO ₂	36.423	38.984	0.010	0.085	0.908
Waste	Incineration and open burning of waste		CO ₂	2.551	3.448	0.002	0.015	0.923
LULUCF	Grassland remaining grassland		CO ₂	0.206	1.292	0.002	0.014	0.937
Waste	Wastewater treatment and discharge		N ₂ O	7.154	5.250	0.002	0.013	0.950
Agriculture	Agricultural soils		N ₂ O	0.857	1.712	0.001	0.012	0.962
Waste	Solid waste disposal		CH ₄	4.551	4.736	0.001	0.009	0.971
Agriculture	Enteric fermentation		CH ₄	7.627	6.274	0.001	0.006	0.977
Waste	Incineration and open burning of waste		CH ₄	2.692	1.947	0.001	0.005	0.982
Energy	Road transportation		N ₂ O	0.627	0.895	0.001	0.004	0.987
Industry	Paraffin wax use		CO ₂	0.251	0.419	0.000	0.002	0.989
Energy	Combustion excluding transport		N ₂ O	1.339	1.316	0.000	0.002	0.991
Industry	Limestone and dolomite use		CO ₂	0.000	0.110	0.000	0.001	0.992
Energy	Road transportation		CH ₄	0.068	0.166	0.000	0.001	0.993
Industry	Solvent use		CO ₂	0.263	0.325	0.000	0.001	0.995
Energy	Combustion excluding transport		CH ₄	1.133	1.085	0.000	0.001	0.996
Waste	Incineration and open burning of waste		N ₂ O	0.741	0.573	0.000	0.001	0.997
LULUCF	Forest land remaining forest land		CO ₂	0.000	-0.066	0.000	0.001	0.997
Energy	Domestic aviation		N ₂ O	0.323	0.225	0.000	0.001	0.998
LULUCF	Land converted to cropland		CO ₂	0.000	0.048	0.000	0.001	0.999
Industry	Emission of SF ₆		SF ₆	0.034	0.003	0.000	0.000	0.999
Energy	Domestic navigation		N ₂ O	0.051	0.065	0.000	0.000	0.999
Energy	Domestic navigation		CH ₄	0.036	0.045	0.000	0.000	1.000
Agriculture	Manure management		CH ₄	0.186	0.152	0.000	0.000	1.000
LULUCF	Forest land		N ₂ O	0.052	0.055	0.000	0.000	1.000
LULUCF	Grassland		CO ₂	0.004	0.010	0.000	0.000	1.000
Agriculture	Liming		CO ₂	0.008	0.004	0.000	0.000	1.000
Agriculture	Manure management		N ₂ O	0.869	0.770	0.000	0.000	1.000
Energy	Domestic aviation		CH ₄	0.007	0.005	0.000	0.000	1.000
Industry	Paraffin wax use		N ₂ O	0.001	0.001	0.000	0.000	1.000
Industry	Paraffin wax use		CH ₄	0.000	0.000	0.000	0.000	1.000
Industry	Road paving with asphalt		CO ₂	0.000	0.000	0.000	0.000	1.000
Industry	Road paving with asphalt		CH ₄	0.000	0.000	0.000	0.000	1.000
Industry	Asphalt roofing		CO ₂	0.000	0.000	0.000	0.000	1.000
LULUCF	Forest land		CH ₄	0.000	0.000	0.000	0.000	1.000
Total				653.283	576.690	0.122	1.000	

Table 16.11.4 Summary of Key Category Analysis for Greenland for level assessment for year 1990/95 and 2020 and for trend for the years 1990-2020.

Summary of Key Category analysis for Greenland			Key categories with number according to ranking in analysis			
IPCC Source Categories (LULUCF included)			GHG	Identification criteria		
				Level Tier1 1990	Level Tier1 2020	Trend Tier1 1990-2020
Energy	Combustion excluding transport	Liquid fuels	CO ₂	1	1	1
Energy	Combustion excluding transport	Other fuels	CO ₂		6	3
Energy	Combustion excluding transport		CH ₄			
Energy	Combustion excluding transport		N ₂ O			
Energy	Domestic aviation		CO ₂	2	3	5
Energy	Domestic aviation		CH ₄			
Energy	Domestic aviation		N ₂ O			
Energy	Road transportation		CO ₂	3	2	6
Energy	Road transportation		CH ₄			
Energy	Road transportation		N ₂ O			
Energy	Domestic navigation		CO ₂	4	4	4
Energy	Domestic navigation		CH ₄			
Energy	Domestic navigation		N ₂ O			
Industry	Limestone and dolomite use		CO ₂			
Industry	Paraffin wax use		CO ₂			
Industry	Paraffin wax use		CH ₄			
Industry	Paraffin wax use		N ₂ O			
Industry	Solvent use		CO ₂			
Industry	Road paving with asphalt		CO ₂			
Industry	Road paving with asphalt		CH ₄			
Industry	Asphalt roofing		CO ₂			
Industry	Emission of HFC's		HFCs		5	2
Industry	Emission of SF ₆		SF ₆			
Agriculture	Enteric fermentation		CH ₄	5	7	
Agriculture	Manure management		CH ₄			
Agriculture	Manure management		N ₂ O			
Agriculture	Agricultural soils		N ₂ O			
Agriculture	Liming		CO ₂			
Waste	Solid waste disposal		CH ₄			
Waste	Incineration and open burning of waste		CO ₂			7
Waste	Incineration and open burning of waste		CH ₄			
Waste	Incineration and open burning of waste		N ₂ O			
Waste	Wastewater treatment and discharge		N ₂ O			9
LULUCF	Forest land remaining forest land		CO ₂			
LULUCF	Forest land		CH ₄			
LULUCF	Forest land		N ₂ O			
LULUCF	Land converted to cropland		CO ₂			
LULUCF	Grassland remaining grassland		CO ₂			8
LULUCF	Grassland		CO ₂			

16.12 Annex 2 Detailed discussion of methodology and data for estimating CO₂ emission from fossil fuel combustion

Detailed information regarding the methodology and input data used to calculate CO₂ emissions from fossil fuel combustion is included in Section 16.3.

16.13 Annex 3 Other detailed methodological descriptions for individual source or sink categories

All methodological descriptions are included in Sections 16.3 – 16.7 and Section 16.10.

16.14 Annex 4 CO₂ reference approach and comparison with sectoral approach, and relevant information on the national energy balance

See Section 16.3.6 of this annex for the results of the comparison between the sectoral and reference approach.

16.15 Annex 5 Assessment of completeness and (potential) sources and sinks of greenhouse gas emissions and removals excluded

16.15.1 GHG inventory

The Greenlandic greenhouse gas emission inventories for 1990-2020 include all sources identified by the 2006 IPCC Guidelines and the 2000 IPCC Good Practice Guidance except the following:

In the Industrial Processes and Product Use sector, no N₂O emissions are included in (CRF category 2D3) Solvent Use. With regard to N₂O from fire extinguishers (CRF category 2G3b) the notation key NE was priorily used. However, a Danish research on the matter has showed that N₂O is not used in fire extinguishers. Since Greenland imports all fireextinguishers from Denmark, the notation key on N₂O in fire extinguishers has been changed from NE to NO concerning every year in the time series 1990-2018. With regard to aerosol cans, we are aware that N₂O is found in the products. However, since we cannot find any activity data on aerosol cans, we continue to report the notation key NE for N₂O in aerosol cans.

Direct and indirect CH₄ emissions from agricultural soils are not estimated. Direct and indirect soil emissions are considered of minor importance for CH₄.

In the LULUCF sector, emissions/removals from wetlands, settlements and other land are currently not estimated due to the lack of available data. The lack of data availability is also an issue for other aspects of LULUCF, e.g. harvested wood products. For more detail, please see Section 16.6.

In the Waste sector, CO₂ emissions from managed waste disposal on land are not estimated. According to the 2006 IPCC Guidelines: "Decomposition of organic material deriving from biomass sources (e.g., crops, wood) is the primary source of CO₂ release from waste. These CO₂ emissions are not included in national totals, because the carbon is of biogenic origin and net emissions are accounted for under the AFOLU Sector."

16.15.2 KP-LULUCF inventory

The KP-LULUCF inventory is considered complete. The carbon pools not estimated has been documented as not being sources, please see Section 16.10 for further documentation.

16.16 Annex 6 Additional information to be considered as part of the annual inventory submission and the supplementary information required under Article 7, paragraph 1, of the Kyoto Protocol or other useful reference information

No additional information for Greenland is deemed relevant.

16.17 Annex 7 Tables 6.1 and 6.2 of the IPCC good practice guidance

IPCC Source category	Gas	Base year emission	Year t emission	Activity data uncertainty	Emission factor uncertainty	Combined uncertainty	Combined uncertainty as % of total national emissions in year t	Type A sensitivity	Type B sensitivity	Uncertainty in trend in national emissions introduced by emission factor uncertainty	Uncertainty in trend in national emissions introduced by activity data uncertainty	Uncertainty introduced into the trend in total national emissions
		Input data Gg CO ₂ eq	Input data Gg CO ₂ eq	Input data %	Input data %	%	%	%	%	%	%	%
1A Liquid fuels	CO ₂	620	524	3	2	3.606	10.723	0.036	0.802	0.071	3.401	11.575
1A Municipal waste	CO ₂	2	9	3	25	25.179	0.160	0.012	0.014	0.294	0.059	0.090
1A Liquid fuels	CH ₄	1	1	3	100	100.045	0.039	0.000	0.002	0.011	0.007	0.000
1A Municipal waste	CH ₄	0	0	3	100	100.045	0.000	0.000	0.000	0.009	0.000	0.000
1A Biomass	CH ₄	0	0	3	100	100.045	0.000	0.000	0.000	0.011	0.001	0.000
1A Liquid fuels	N ₂ O	2	2	3	500	500.009	3.787	0.000	0.003	0.173	0.015	0.030
1A Municipal waste	N ₂ O	0	0	3	500	500.009	0.010	0.000	0.000	0.072	0.001	0.005
1A Biomass	N ₂ O	0	0	3	200	200.022	0.002	0.000	0.000	0.035	0.001	0.001
1B2 Oil exploration	CO ₂	0	0	3	1000	1 000.004	0.000	0.000	0.000	0.000	0.000	0.000
1B2 Oil exploration	CH ₄	0	0	3	1000	1 000.004	0.000	0.000	0.000	0.000	0.000	0.000
1B2 Oil exploration	N ₂ O	0	0	3	1000	1 000.004	0.000	0.000	0.000	0.000	0.000	0.000
2A4 Limestone and dolomite use	CO ₂	0	0	5	5	7.071	0.000	0.000	0.000	0.001	0.001	0.000
2D2 Paraffin wax use	CO ₂	0	0	5	25	25.495	0.000	0.000	0.001	0.008	0.005	0.000
2D2 Paraffin wax use	N ₂ O	0	0	5	25	25.495	0.000	0.000	0.000	0.000	0.000	0.000
2D2 Paraffin wax use	CH ₄	0	0	5	25	25.495	0.000	0.000	0.000	0.000	0.000	0.000
2D3 Solvent use	CO ₂	0	0	5	25	25.495	0.000	0.000	0.000	0.004	0.004	0.000
2D3 Road paving with asphalt	CO ₂	0	0	5	25	25.495	0.000	0.000	0.000	0.000	0.000	0.000
2D3 Road paving with asphalt	CH ₄	0	0	5	25	25.495	0.000	0.000	0.000	0.000	0.000	0.000
2D3 Asphalt roofing	CO ₂	0	0	5	25	25.495	0.000	0.000	0.000	0.000	0.000	0.000
2F Emission of HFC	HFC	0	13	10	50	50.990	1.303	0.020	0.020	0.986	0.279	1.050
2G Emission of SF ₆	SF ₆	0	0	10	50	50.990	0.000	0.000	0.000	0.002	0.000	0.000

Continued

IPCC Source category	Gas	Base year emission	Year t emission	Activity data	Emission factor	Combined emissions in year t	Combined uncertainty as % of total national	Type A sensitivity	Type B sensitivity	Uncertainty	Uncertainty	Uncertainty	
										in trend in national emissions introduced by emission factor	in trend in national emissions introduced by activity data	introduced into the trend in total national emissions	
										uncertainty	uncertainty	emissions	
		Input data	Input data	Input data	Input data								
		Gg CO ₂ eq	Gg CO ₂ eq	%	%	%	%	%	%	%	%	%	
3A Enteric Fermentation	CH ₄	8	6	10	100	100.499	1.195	0.001	0.010	0.070	0.136	0.023	
3B Manure Management	CH ₄	0	0	10	100	100.499	0.001	0.000	0.000	0.002	0.003	0.000	
3B Manure Management	N ₂ O	1	1	10	100	100.499	0.018	0.000	0.001	0.000	0.017	0.000	
3D Agricultural soils	N ₂ O	1	2	20	50	53.852	0.026	0.001	0.003	0.073	0.074	0.011	
3G Liming	CO ₂	0	0	5	50	50.249	0.000	0.000	0.000	0.000	0.000	0.000	
4A Forest	CO ₂	0	0	5	50	50.249	0.000	0.000	0.000	0.005	0.001	0.000	
4A Forest	CH ₄	0	0	5	50	50.249	0.000	0.000	0.000	0.000	0.000	0.000	
4A Forest	N ₂ O	0	0	5	50	50.249	0.000	0.000	0.000	0.001	0.001	0.000	
4B Cropland	CO ₂	0	0	5	50	50.249	0.000	0.000	0.000	0.004	0.001	0.000	
4C Grassland	CO ₂	0	1	5	50	50.249	0.013	0.002	0.002	0.085	0.014	0.007	
4C Grassland	CH ₄	0	0	5	50	50.249	0.000	0.000	0.000	0.000	0.000	0.000	
5A Solid Waste Disposal	CH ₄	5	5	10	100	100.499	0.681	0.001	0.007	0.110	0.103	0.023	
5C Incineration and open burning of waste	CO ₂	3	3	10	25	26.926	0.026	0.002	0.005	0.046	0.075	0.008	
5C Incineration and open burning of waste	CH ₄	3	2	10	50	50.990	0.030	0.001	0.003	0.033	0.042	0.003	
5C Incineration and open burning of waste	N ₂ O	1	1	10	100	100.499	0.010	0.000	0.001	0.012	0.012	0.000	
5D Wastewater treatment and discharge	N ₂ O	7	5	30	100	104.403	0.903	0.002	0.008	0.163	0.341	0.143	
Total		653	577				18,928					12,970	
Total uncertainties				Overall uncertainty in the year (%):				4.351			Trend uncertainty (%):		3.601

16.18 Annex 8 Results of a technical analysis conducted on the Greenlandic gasoil

In 2013, a technical analysis has been conducted on the arctic gasoil that is by far the most dominant type of fuel in Greenland. The analysis was conducted by the Danish Technological Institute in order to gain a country specific emission factor on the Greenlandic gasoil.

Table 16.18.1 shows the results of the technological analysis on the Greenlandic gasoil. The CO₂ emission factor was revised in the 2015 submission due to an increase in the recommended oxidation factor from 0.99 to 1.0.

Table 16.18.1 Results on the technical analysis on the Greenlandic gasoil

	Test result	Method
C, %	85.4	Elementaranalyse
Upper calorific, J/g	45860	DS/CEN/TS 14918
Lower calorific, J/g	42900	Calculation
CO ₂ emission factor, kg CO ₂ /GJ	72.967	Calculation

17 Information regarding the aggregated submission for Denmark and Greenland

This chapter contains information on the aggregated submission for Denmark and Greenland submitted under the Kyoto Protocol. This chapter contains a trend discussion, an approach 1 uncertainty analysis, information on the aggregated reference approach, information relating to key categories and information on recalculations. Sector specific information is included for Denmark in Chapter 3-10 and for Greenland in Chapter 16.

The institutional arrangements and the overall QA/QC plan are described in Chapter 1. This description covers all the Danish submissions to the European Union, the UNFCCC and the Kyoto Protocol, and therefore information regarding the national system is not presented in this chapter. Information on the specific QA/QC activities concerning the aggregated submission is presented in Chapter 17.7.

In Chapter 17.6, a description of the aggregation process is provided. The chapter explains the technical issues in aggregating two CRF submissions, including the software used in the process and the handling of background data.

17.1 Trends in emissions

Due to the small emissions originating from Greenland, the trends for Denmark and Greenland are practically identical to the trends for Denmark presented in Chapter 2. Therefore, they are not further described here.

17.2 The reference approach

In addition to the sector-specific CO₂ emission inventories (the national approach), the CO₂ emission is also estimated using the reference approach described in the 2006 IPCC Guidelines. The reference approach is based on data for fuel production, import, export and stock change. The CO₂ emission inventory based on the reference approach is reported to the Climate Convention and used for verification of the official data in the national approach.

The reference approach for Denmark and Greenland is an aggregation of the individual reference approaches for the two. The reference approach for Denmark is described in Chapter 3.4 and the reference approach for Greenland is included in Chapter 16.

The difference between the two methods is almost exclusively caused by the difference between the Danish sectoral and reference approach. Please refer to Chapter 3.4 for more information.

17.3 Uncertainties

An uncertainty estimate has been calculated for Denmark and Greenland. The uncertainty estimate for Denmark is included in Chapter 1.7 and for Greenland in Chapter 16.

The uncertainty estimates are based on the Approach 1 methodology in the 2006 IPCC Guidelines. Uncertainty estimates cover 100 % of the total net greenhouse gas emissions and removals. The emissions from Greenland have been treated separately due to the uncertainties being different than the uncertainties in the Danish inventory. The uncertainty of the Greenlandic emissions has almost no effect on the overall uncertainty estimate, due to the low emissions originating from Greenland.

The estimated uncertainties for total GHG and for CO₂, CH₄, N₂O and F-gases are shown in Table 17.1. The base year for F-gases is 1995 and for all other sources the base year is 1990. The total net GHG emission from Denmark and Greenland is estimated with an uncertainty of ±13.8 % and the trend in net GHG emission since 1990/1995 has been estimated to be -41.9 % ± 3.0 %-age points. The GHG uncertainty estimates do not take into account the uncertainty of the GWP factors.

Table 17.1 Uncertainties 1990-2020.

	Uncertainty [%]	Trend [%]	Uncertainty in trend [%-age points]
GHG	13.8	-41.9	3.0
GHG ex. LULUCF	14.3	-40.7	3.1
CO ₂	5.6	-47.9	1.6
CH ₄	14.3	-10.0	11.2
N ₂ O	102	-32	21
F-gases	44	-4	45

The uncertainties shown in Table 17.1 are practically identical to the values for Denmark only presented in Chapter 1. The uncertainties for the activity rates and emission factors are shown in Table 17.2.

Table 17.2 Uncertainties for activity rates and emission factors.

IPCC Source category		Gas	Base year emission Input data kt CO ₂ eqv.	2020 emission Input data kt CO ₂ eqv.	Activity data uncertainty Input data %	Emission factor un- certainty Input data %
Denmark	1A Stationary combustion, Coal, ETS data, CO ₂	CO ₂	0.0	2966.2	0.5	0.3
Denmark	1A Stationary combustion, Coal, no ETS data, CO ₂	CO ₂	23826.7	134.6	1.6	1.0
Denmark	1A Stationary combustion, BKB, CO ₂	CO ₂	11.3	0.0	2.9	5.0
Denmark	1A Stationary combustion, Coke oven coke, CO ₂	CO ₂	136.5	41.4	1.8	5.0
Denmark	1A Stationary combustion, Fossil waste, ETS data, CO ₂	CO ₂	0.0	1392.8	2.0	3.0
Denmark	1A Stationary combustion, Fossil waste, no ETS data, CO ₂	CO ₂	573.5	459.0	5.0	10.0
Denmark	1A Stationary combustion, Petroleum coke, ETS data, CO ₂	CO ₂	0.0	703.3	0.5	0.5
Denmark	1A Stationary combustion, Petroleum coke, no ETS data, CO ₂	CO ₂	414.7	31.2	2.0	5.0
Denmark	1A Stationary combustion, Residual oil, ETS data, CO ₂	CO ₂	0.0	227.7	0.5	0.5
Denmark	1A Stationary combustion, Residual oil, no ETS data, CO ₂	CO ₂	2526.6	16.2	1.0	2.0
Denmark	1A Stationary combustion, Gas oil, CO ₂	CO ₂	5164.5	564.0	2.4	1.3
Denmark	1A Stationary combustion, Kerosene, CO ₂	CO ₂	367.6	3.3	2.8	3.0
Denmark	1A Stationary combustion, LPG, CO ₂	CO ₂	195.3	150.4	1.9	4.0
Denmark	1A1b Stationary combustion, Petroleum refining, Refinery gas, CO ₂	CO ₂	816.1	872.6	1.0	0.5
Denmark	1A Stationary combustion, Natural gas, onshore, CO ₂	CO ₂	3790.5	3898.1	1.5	0.4
Denmark	1A1c_ii Stationary combustion, Oil and gas extraction, Off shore gas turbines, Natural gas, CO ₂	CO ₂	544.9	872.3	0.5	0.5
Denmark	1A1 Stationary Combustion, Solid fuels, CH ₄	CH ₄	5.3	0.6	1.0	100.0
Denmark	1A1 Stationary Combustion, Liquid fuels, CH ₄	CH ₄	0.7	0.5	1.0	100.0
Denmark	1A1 Stationary Combustion, not engines, gaseous fuels, CH ₄	CH ₄	0.8	1.1	1.0	100.0
Denmark	1A1 Stationary Combustion, Waste, CH ₄	CH ₄	0.2	0.3	3.0	100.0
Denmark	1A1 Stationary Combustion, not engines, Biomass, CH ₄	CH ₄	3.3	13.5	3.0	100.0

IPCC Source category		Gas	Base year emission Input data kt CO ₂ eqv.	2020 emission Input data kt CO ₂ eqv.	Activity data uncertainty Input data %	Emission factor un- certainty Input data %
Denmark	1A2 Stationary Combustion, solid fuels, CH ₄	CH ₄	3.8	1.1	2.0	100.0
Denmark	1A2 Stationary Combustion, Liquid fuels, CH ₄	CH ₄	0.9	0.7	2.0	100.0
Denmark	1A2 Stationary Combustion, not engines, gaseous fuels, CH ₄	CH ₄	0.6	0.6	2.0	100.0
Denmark	1A2 Stationary Combustion, Waste, CH ₄	CH ₄	0.0	2.6	3.0	100.0
Denmark	1A2 Stationary Combustion, not engines, Biomass, CH ₄	CH ₄	1.6	1.2	3.0	100.0
Denmark	1A4 Stationary Combustion, Solid fuels, CH ₄	CH ₄	6.2	0.0	3.0	100.0
Denmark	1A4 Stationary Combustion, Liquid fuels, CH ₄	CH ₄	3.0	0.3	3.0	100.0
Denmark	1A4 Stationary Combustion, not engines, gaseous fuels, CH ₄	CH ₄	0.6	0.7	3.0	100.0
Denmark	1A4 Stationary Combustion, Waste, CH ₄	CH ₄	0.7	0.0	3.0	100.0
Denmark	1A4 Stationary Combustion, not engines, not residential wood and not residential/agricultural straw, Biomass, CH ₄	CH ₄	0.1	0.4	3.0	100.0
Denmark	1A4b_i Stationary combustion, Residential wood combustion, CH ₄	CH ₄	72.3	39.0	10.0	150.0
Denmark	1A4b_i/1A4c_i Stationary Combustion, Residential and agricultural straw combustion, CH ₄	CH ₄	63.6	35.5	10.0	150.0
Denmark	1A Stationary combustion, Natural gas fuelled engines, gaseous fuels, CH ₄	CH ₄	5.5	42.3	1.0	2.0
Denmark	1A Stationary combustion, Biogas fuelled engines, Biomass, CH ₄	CH ₄	2.2	61.9	3.0	10.0
Denmark	1A1 Stationary Combustion, Solid fuels, N ₂ O	N ₂ O	57.4	6.9	1.0	400.0
Denmark	1A1 Stationary Combustion, Liquid fuels, N ₂ O	N ₂ O	2.8	1.3	1.0	1000.0
Denmark	1A1 Stationary Combustion, Gaseous fuels, N ₂ O	N ₂ O	11.8	9.2	1.0	750.0
Denmark	1A1 Stationary Combustion, Waste, N ₂ O	N ₂ O	5.2	13.7	3.0	400.0
Denmark	1A1 Stationary Combustion, Biomass, N ₂ O	N ₂ O	8.4	44.8	3.0	400.0
Denmark	1A2 Stationary Combustion, Solid fuels, N ₂ O	N ₂ O	6.7	19.4	2.0	400.0
Denmark	1A2 Stationary Combustion, Liquid fuels, N ₂ O	N ₂ O	29.1	6.8	2.0	1000.0
Denmark	1A2 Stationary Combustion, Gaseous fuels, N ₂ O	N ₂ O	7.2	7.1	2.0	750.0
Denmark	1A2 Stationary Combustion, Waste, N ₂ O	N ₂ O	0.0	4.1	3.0	400.0
Denmark	1A2 Stationary Combustion, Biomass, N ₂ O	N ₂ O	12.1	9.5	3.0	400.0
Denmark	1A4 Stationary Combustion, Solid fuels, N ₂ O	N ₂ O	1.5	0.1	3.0	400.0
Denmark	1A4 Stationary Combustion, Liquid fuels, N ₂ O	N ₂ O	11.7	1.0	3.0	1000.0
Denmark	1A4 Stationary Combustion, Gaseous fuels, N ₂ O	N ₂ O	7.7	8.7	3.0	750.0
Denmark	1A4 Stationary Combustion, Waste, N ₂ O	N ₂ O	1.1	0.0	3.0	400.0
Denmark	1A4 Stationary Combustion, not residential wood and not residential/agricultural straw, Biomass, N ₂ O	N ₂ O	0.5	4.6	3.0	400.0
Denmark	1A4b_i Stationary Combustion, Residential wood combustion, N ₂ O	N ₂ O	10.7	36.2	10.0	500.0
Denmark	1A4b_i/1A4c_i Stationary Combustion, Residential and agricultural straw combustion, N ₂ O	N ₂ O	10.1	5.6	10.0	500.0
Denmark	1.A.2.g Industry (mobile)	CO ₂	533.5	542.2	41.0	5.0
Denmark	1.A.3.a Civil aviation	CO ₂	225.9	78.0	10.0	5.0
Denmark	1.A.3.b Road Transport	CO ₂	9370.8	11139.9	2.0	5.0
Denmark	1.A.3.c Railways	CO ₂	297.1	196.7	2.0	5.0
Denmark	1.A.3.d Navigation (large vessels)	CO ₂	715.2	477.7	11.0	5.0
Denmark	1.A.4.a Commercial/Institutional (mobile)	CO ₂	162.5	199.4	35.0	5.0
Denmark	1.A.4.b Residential (mobile)	CO ₂	18.8	19.9	35.0	5.0
Denmark	1.A.4.c ii Agriculture (mobile)	CO ₂	821.1	816.5	24.0	5.0
Denmark	1.A.4.c ii Forestry (mobile)	CO ₂	35.9	44.2	30.0	5.0
Denmark	1.A.4.c iii Fisheries	CO ₂	614.8	264.2	2.0	5.0
Denmark	1.A.5.b Other (military)	CO ₂	48.0	96.7	41.0	5.0
Denmark	1.A.5.b Other (small boats)	CO ₂	119.0	146.5	2.0	5.0
Denmark	1.A.2.g Industry (mobile)	CH ₄	1.2	0.4	41.0	100.0
Denmark	1.A.3.a Civil aviation	CH ₄	0.1	0.0	10.0	100.0
Denmark	1.A.3.b Road Transport	CH ₄	78.6	7.9	2.0	40.0
Denmark	1.A.3.c Railways	CH ₄	0.3	0.1	2.0	100.0

IPCC Source category		Gas	Base year emission Input data kt CO ₂ eqv.	2020 emission Input data kt CO ₂ eqv.	Activity data uncertainty Input data %	Emission factor un- certainty Input data %
Denmark	1.A.3.d Navigation (large vessels)	CH ₄	0.4	0.8	11.0	100.0
Denmark	1.A.4.a Commercial/Institutional (mobile)	CH ₄	0.8	0.8	35.0	100.0
Denmark	1.A.4.b Residential (mobile)	CH ₄	0.9	0.4	35.0	100.0
Denmark	1.A.4.c ii Agriculture (mobile)	CH ₄	1.5	0.9	24.0	100.0
Denmark	1.A.4.c ii Forestry (mobile)	CH ₄	4.0	0.4	30.0	100.0
Denmark	1.A.4.c iii Fisheries	CH ₄	0.3	0.1	2.0	100.0
Denmark	1.A.5.b Other (military)	CH ₄	1.9	0.2	41.0	100.0
Denmark	1.A.5.b Other (small boats)	CH ₄	0.1	0.1	2.0	100.0
Denmark	1.A.2.g Industry (mobile)	N ₂ O	6.2	7.6	41.0	1000.0
Denmark	1.A.3.a Civil aviation	N ₂ O	3.1	1.2	10.0	1000.0
Denmark	1.A.3.b Road Transport	N ₂ O	87.4	123.8	2.0	50.0
Denmark	1.A.3.c Railways	N ₂ O	2.7	1.8	2.0	1000.0
Denmark	1.A.3.d Navigation (large vessels)	N ₂ O	5.3	3.6	11.0	1000.0
Denmark	1.A.4.a Commercial/Institutional (mobile)	N ₂ O	1.9	2.3	35.0	1000.0
Denmark	1.A.4.b Residential (mobile)	N ₂ O	0.1	0.1	35.0	1000.0
Denmark	1.A.4.c ii Agriculture (mobile)	N ₂ O	9.4	11.5	24.0	1000.0
Denmark	1.A.4.c ii Forestry (mobile)	N ₂ O	0.2	0.6	30.0	1000.0
Denmark	1.A.4.c iii Fisheries	N ₂ O	4.5	1.9	2.0	1000.0
Denmark	1.A.5.b Other (military)	N ₂ O	0.4	1.0	41.0	1000.0
Denmark	1.A.5.b Other (small boats)	N ₂ O	1.1	1.6	2.0	1000.0
Denmark	1.B.2.a.1 Exploration	CO ₂	4.7	0.0	2.0	10.0
Denmark	1.B.2.a.2 Production	CO ₂	0.0	0.0	2.0	100.0
Denmark	1.B.2.a.4 Refining/storage	CO ₂	0.0	0.1	2.0	40.0
Denmark	1.B.2.b.1 Exploration	CO ₂	8.2	0.0	2.0	10.0
Denmark	1.B.2.b.2 Production	CO ₂	0.1	0.0	2.0	100.0
Denmark	1.B.2.b.4 Transmission and storage	CO ₂	0.0	0.0	15.0	2.0
Denmark	1.B.2.b.5 Distribution	CO ₂	0.0	0.0	25.0	10.0
Denmark	1.B.2.c.1.ii Venting	CO ₂	0.0	0.0	15.0	2.0
Denmark	1.B.2.c.2.i Flaring, oil	CO ₂	22.9	15.7	11.0	2.0
Denmark	1.B.2.c.2.ii Flaring, gas	CO ₂	2.1	1.3	7.5	2.0
Denmark	1.B.2.c.2.iii Flaring, combined	CO ₂	302.6	109.1	7.5	2.0
Denmark	1.B.2.a.1 Exploration	CH ₄	0.0	0.0	2.0	125.0
Denmark	1.B.2.a.2 Production	CH ₄	0.1	0.1	2.0	100.0
Denmark	1.B.2.a.3 Transport	CH ₄	12.3	0.8	2.0	100.0
Denmark	1.B.2.a.4 Refining/storage	CH ₄	30.6	17.8	1.0	200.0
Denmark	1.B.2.b.1 Exploration	CH ₄	0.8	0.0	2.0	125.0
Denmark	1.B.2.b.2 Production	CH ₄	48.8	13.3	2.0	100.0
Denmark	1.B.2.b.4 Transmission and storage	CH ₄	3.6	4.9	15.0	2.0
Denmark	1.B.2.b.5 Distribution	CH ₄	6.4	3.5	25.0	10.0
Denmark	1.B.2.c.1.ii Venting	CH ₄	1.5	1.0	15.0	2.0
Denmark	1.B.2.c.2.i Flaring, oil	CH ₄	0.2	0.1	11.0	15.0
Denmark	1.B.2.c.2.ii Flaring, gas	CH ₄	0.0	0.0	7.5	2.0
Denmark	1.B.2.c.2.iii Flaring, combined	CH ₄	28.6	11.7	7.5	125.0
Denmark	1.B.2.a.1 Exploration, oil	N ₂ O	1.4	0.0	2.0	1000.0
Denmark	1.B.2.c.2.i Flaring, oil	N ₂ O	0.1	0.0	11.0	1000.0
Denmark	1.B.2.c.2.ii Flaring, gas	N ₂ O	0.0	0.0	7.5	1000.0
Denmark	1.B.2.c.2.iii Flaring, combined	N ₂ O	51.6	21.1	7.5	1000.0
Denmark	2A1 Cement production	CO ₂	882.4	1227.0	1.6	2.0
Denmark	2A2 Lime production	CO ₂	105.4	43.2	1.4	4.0
Denmark	2A3 Glass production	CO ₂	16.5	9.8	1.0	2.0
Denmark	2A4a Ceramics	CO ₂	46.1	43.4	5.0	2.0
Denmark	2A4b Other uses of soda ash	CO ₂	13.8	17.3	5.0	2.0

IPCC Source category		Gas	Base year emission Input data kt CO ₂ eqv.	2020 emission Input data kt CO ₂ eqv.	Activity data uncertainty Input data %	Emission factor un- certainty Input data %
Denmark	2A4d Other process uses of carbonates	CO ₂	17.0	12.7	4.0	2.0
Denmark	2B10 Production of catalysts	CO ₂	0.6	1.4	5.0	5.0
Denmark	2C1a Steel	CO ₂	30.3	0.0	5.0	10.0
Denmark	2C5 Lead production	CO ₂	0.2	0.1	10.0	50.0
Denmark	2D1 Lubricant use	CO ₂	49.7	31.7	5.0	10.0
Denmark	2D2 Paraffin wax use	CO ₂	21.7	57.6	10.0	20.0
Denmark	Paint Application	CO ₂	12.9	6.8	10.0	15.0
Denmark	Degreasing, dry cleaning and electronics	CO ₂	0.0	0.0	10.0	15.0
Denmark	Chemical products manufacturing or processing	CO ₂	19.4	16.1	10.0	15.0
Denmark	Other use of solvents and related activities	CO ₂	52.0	39.3	10.0	20.0
Denmark	Printing industry	CO ₂	0.0	0.0	10.0	15.0
Denmark	Domestic solvent use (other than paint application)	CO ₂	9.4	6.8	10.0	15.0
Denmark	2D3 Road paving with asphalt	CO ₂	0.6	0.9	5.0	75.0
Denmark	2D3 Asphalt roofing	CO ₂	0.0	0.0	5.0	75.0
Denmark	2D3 Urea based catalysts	CO ₂	0.0	9.1	5.0	10.0
Denmark	2G4 Fireworks	CO ₂	0.1	0.2	5.0	50.0
Denmark	2D2 Paraffin wax use	CH ₄	0.0	0.1	10.0	20.0
Denmark	2D3 Road paving with asphalt	CH ₄	0.3	0.4	5.0	75.0
Denmark	2G4 Fireworks	CH ₄	0.0	0.1	5.0	50.0
Denmark	2G4 Tobacco	CH ₄	1.0	0.4	5.0	50.0
Denmark	2G4 Charcoal	CH ₄	1.1	1.0	5.0	100.0
Denmark	2B2 Nitric acid production	N ₂ O	1002.5	0.0	2.0	25.0
Denmark	2D2 Paraffin wax use	N ₂ O	0.1	0.1	10.0	20.0
Denmark	2G3a Medical application of N ₂ O	N ₂ O	11.3	11.3	25.0	20.0
Denmark	2G3b N ₂ O as propellant for pressure and aerosol products	N ₂ O	5.3	5.9	100.0	150.0
Denmark	2G4 Fireworks	N ₂ O	0.7	2.4	5.0	50.0
Denmark	2G4 Tobacco	N ₂ O	0.3	0.1	5.0	50.0
Denmark	2G4 Charcoal	N ₂ O	0.1	0.1	5.0	100.0
Denmark	2E Electronics industry	HFCs	0.0	0.0	0.0	0.0
Denmark	2F1 Refrigeration and air conditioning	HFCs	47.6	322.8	10.0	50.0
Denmark	2F2 Foam blowing agents	HFCs	210.3	0.6	10.00	50.00
Denmark	2F4 Aerosols	HFCs	0.0	11.1	10.00	50.00
Denmark	2E Electronics industry	PFCs	0.0	0.0	10.00	50.00
Denmark	2F1 Refrigeration and air conditioning	PFCs	0.6	0.0	10.00	50.00
Denmark	2C4 Magnesium production	SF ₆	34.2	0.0	10.00	30.00
Denmark	2G1 Electrical equipment	SF ₆	3.7	13.1	10.00	50.00
Denmark	2G2 SF ₆ and PFCs from other product use	SF ₆	65.9	32.4	10.00	50.00
Denmark	3A Enteric Fermentation	CH ₄	4039.5	3679.6	2.00	20.00
Denmark	3B Manure Management	CH ₄	1855.3	2197.7	5.00	20.00
Denmark	3F Field Burning of Agricultural Residues	CH ₄	2.2	3.8	25.00	50.00
Denmark	3B Manure Management	N ₂ O	770.1	546.1	20.00	100.00
Denmark	3B5 Atmospheric deposition	N ₂ O	196.3	127.0	15.00	100.00
Denmark	3Da1 Inorganic N fertilizer	N ₂ O	1875.0	1179.5	3.00	300.00
Denmark	3Da2a Animal manure applied to soils	N ₂ O	991.0	986.9	25.00	300.00
Denmark	3Da2b Sewage sludge applied to soils	N ₂ O	14.6	17.5	15.00	300.00
Denmark	3Da2c Other organic fertilizer applied to soils	N ₂ O	7.2	25.5	20.00	300.00
Denmark	3Da3 Urine and dung deposited by grazing animals	N ₂ O	297.9	177.9	10.00	300.00
Denmark	3Da4 Crop Residues	N ₂ O	732.9	891.1	25.00	300.00
Denmark	3Da5 Mineralization	N ₂ O	201.8	63.7	50.00	300.00
Denmark	3Da6 Cultivation of organic soils	N ₂ O	817.8	599.9	50.00	300.00
Denmark	3Db1 Atmospheric deposition	N ₂ O	376.1	182.3	15.00	500.00
Denmark	3Db2 Leaching	N ₂ O	545.9	333.6	20.00	300.00

IPCC Source category		Gas	Base year emission Input data kt CO ₂ eqv.	2020 emission Input data kt CO ₂ eqv.	Activity data uncertainty Input data %	Emission factor un- certainty Input data %
Denmark	3F Field Burning of Agricultural Residues	N ₂ O	0.7	1.2	25.00	50.00
Denmark	3G Liming	CO ₂	565.5	249.6	5.00	100.00
Denmark	3H Urea applicaton	CO ₂	14.7	0.9	3.00	100.00
Denmark	3I Other carbon-containing fertilizers	CO ₂	33.3	3.8	3.00	100.00
Denmark	4.A.1 Forest land remaining forest land, Living biomass	CO ₂	-244.4	-300.2	5.00	2.00
Denmark	4.A.1 Forest land remaining forest land, Dead organic matter	CO ₂	-127.0	-836.3	5.00	3.29
Denmark	4.A.1 Forest land remaining forest land, Mineral soils	CO ₂	0.0	0.0	5.00	2.00
Denmark	4.A.1 Forest land remaining forest land, Organic soils	CO ₂	147.4	123.0	10.00	50.00
Denmark	4.A.2 Land converted to forest land	CO ₂	-1036.6	-1186.7	10.00	8.74
Denmark	4.B.1 Cropland remaining cropland, Living biomass	CO ₂	74.6	154.9	2.50	15.00
Denmark	4.B.1 Cropland remaining cropland, Mineral soils	CO ₂	932.2	-109.5	2.50	75.00
Denmark	4.B.1 Cropland remaining cropland, Organic soils	CO ₂	3959.1	2549.0	3.30	50.00
Denmark	4.B.2 Forest land converted to cropland	CO ₂	2.2	119.4	10.00	50.00
Denmark	4.B.2 Other land uses converted to cropland	CO ₂	86.3	-31.6	10.00	50.00
Denmark	4(II) Cropland on organic soils	CO ₂	106.7	70.6	3.30	40.00
Denmark	4.C.1 Grassland remaining grassland, Living biomass	CO ₂	7.5	130.1	2.50	7.00
Denmark	4.C.1 Grassland remaining grassland, Organic soils	CO ₂	1974.2	1873.8	3.30	50.00
Denmark	4.C.2 Forest land converted to grassland	CO ₂	2.4	14.7	10.00	50.00
Denmark	4.C.2 Other land uses converted to grassland	CO ₂	53.7	30.2	10.00	50.00
Denmark	4(II) Grassland on organic soils	CO ₂	72.9	69.4	3.30	40.00
Denmark	4.D.1.1 Peat extraction remaining peat extraction	CO ₂	99.5	8.2	10.00	75.00
Denmark	4.D.1.2 Flooded land remaining flooded land	CO ₂	0.0	0.0	10.00	75.00
Denmark	4.D.2. Land converted to wetlands	CO ₂	3.2	35.4	10.00	75.00
Denmark	4.E.2 Forest land converted to settlements	CO ₂	4.4	35.2	10.00	75.00
Denmark	4.E.2 Other land uses converted to settlements	CO ₂	424.0	189.4	10.00	75.00
Denmark	4.G Harvested wood products	CO ₂	-2.4	-117.6	25.00	75.00
Denmark	4(II) Cropland on organic soils	CH ₄	136.7	92.7	10.00	90.00
Denmark	4(II) Grassland on organic soils	CH ₄	119.0	113.4	10.00	90.00
Denmark	4(II) A. Forest land, organic soils	CH ₄	4.3	3.7	10.00	90.00
Denmark	4(II) Land converted to wetlands	CH ₄	0.5	27.9	10.00	90.00
Denmark	4(II) Peatland	CH ₄	1.3	0.7	10.00	90.00
Denmark	4(V) Biomass Burning	CH ₄	0.7	0.0	10.00	30.00
Denmark	4(III) Mineralization/immobilization, Forest land	N ₂ O	0.0	0.0	10.00	90.00
Denmark	4(III) Mineralization/immobilization, Cropland	N ₂ O	0.1	5.6	10.00	90.00
Denmark	4(III) Mineralization/immobilization, Grassland	N ₂ O	0.0	0.2	10.00	90.00
Denmark	4(III) Mineralization/immobilization, Land converted to Settlements	N ₂ O	43.8	17.5	10.00	90.00
Denmark	4(V) Biomass burning	N ₂ O	0.4	0.0	10.00	30.00
Denmark	4(II) Drainage and rewetting, Forest soils	N ₂ O	26.5	24.2	10.00	50.00
Denmark	4(II) Peat extraction remaining peat extraction	N ₂ O	0.2	0.1	10.00	50.00
Denmark	5.E Accidental fires	CO ₂	21.8	23.0	10.00	300.00
Denmark	5.A Solid waste disposal	CH ₄	1536.3	536.8	10.00	104.52
Denmark	5.B.1 Composting	CH ₄	26.7	85.1	20.00	100.00
Denmark	5.B.2. Anaerobic digestion at biogas facilities	CH ₄	5.6	289.1	5.00	20.00
Denmark	5.C.1 Incineration of corpses	CH ₄	0.0	0.0	1.00	150.00
Denmark	5.C.2 Incineration of carcasses	CH ₄	0.0	0.0	40.00	150.00
Denmark	5.D.1 Domestic wastewater	CH ₄	41.1	52.9	30.00	50.00
Denmark	5.E Accidental fires	CH ₄	2.7	2.8	10.00	500.00
Denmark	5.B.1 Composting	N ₂ O	22.2	72.9	20.00	100.00
Denmark	5.C.1 Incineration of corpses	N ₂ O	0.2	0.2	1.00	150.00
Denmark	5.C.2 Incineration of carcasses	N ₂ O	0.0	0.1	40.00	150.00
Denmark	5.D.1 Domestic wastewater	N ₂ O	112.5	133.0	30.00	50.00

IPCC Source category		Gas	Base year emission Input data kt CO ₂ eqv.	2020 emission Input data kt CO ₂ eqv.	Activity data uncertainty Input data %	Emission factor un- certainty Input data %
Denmark	5.D.2 Industrial wastewater	N ₂ O	126.6	13.9	30.00	50.00
Greenland	1A Liquid fuels	CO ₂	619.9	523.8	3.0	2.0
Greenland	1A Municipal waste	CO ₂	1.7	9.2	3.0	25.0
Greenland	1A Liquid fuels	CH ₄	1.2	1.1	3.0	100.0
Greenland	1A Municipal waste	CH ₄	0.0	0.1	3.0	100.0
Greenland	1A Biomass	CH ₄	0.0	0.1	3.0	100.0
Greenland	1A Liquid fuels	N ₂ O	2.3	2.2	3.0	500.0
Greenland	1A Municipal waste	N ₂ O	0.0	0.1	3.0	500.0
Greenland	1A Biomass	N ₂ O	0.0	0.1	3.0	200.0
Greenland	1B2 Oil exploration	CO ₂	0.0	0.0	3.0	1000.0
Greenland	1B2 Oil exploration	CH ₄	0.0	0.0	3.0	1000.0
Greenland	1B2 Oil exploration	N ₂ O	0.0	0.0	3.0	1000.0
Greenland	2A4 Limestone and dolomite use	CO ₂	0.0	0.1	5.0	5.0
Greenland	2D2 Paraffin wax use	CO ₂	0.3	0.4	5.0	25.0
Greenland	2D2 Paraffin wax use	N ₂ O	0.0	0.0	5.0	25.0
Greenland	2D2 Paraffin wax use	CH ₄	0.0	0.0	5.0	25.0
Greenland	2D3 Solvent use	CO ₂	0.3	0.3	5.0	25.0
Greenland	2D3 Road paving with asphalt	CO ₂	0.0	0.0	5.0	25.0
Greenland	2D3 Road paving with asphalt	CH ₄	0.0	0.0	5.0	25.0
Greenland	2D3 Asphalt roofing	CO ₂	0.0	0.0	5.0	25.0
Greenland	2F Emission of HFC	HFC	0.0	12.9	10.0	50.0
Greenland	2G Emission of SF ₆	SF ₆	0.0	0.0	10.0	50.0
Greenland	3A Enteric Fermentation	CH ₄	7.6	6.3	10.0	100.0
Greenland	3B Manure Management	CH ₄	0.2	0.2	10.0	100.0
Greenland	3B Manure Management	N ₂ O	0.9	0.8	10.0	100.0
Greenland	3D Agricultural soils	N ₂ O	0.9	1.7	20.0	50.0
Greenland	3G Liming	CO ₂	0.0	0.0	5.0	50.0
Greenland	4A Forest	CO ₂	0.0	-0.1	5.0	50.0
Greenland	4A Forest	CH ₄	0.0	0.0	5.0	50.0
Greenland	4A Forest	N ₂ O	0.1	0.1	5.0	50.0
Greenland	4B Cropland	CO ₂	0.0	0.0	5.0	50.0
Greenland	4C Grassland	CO ₂	0.2	1.3	5.0	50.0
Greenland	4C Grassland	CH ₄	0.0	0.0	5.0	50.0
Greenland	5A Solid Waste Disposal	CH ₄	4.6	4.7	10.0	100.0
Greenland	5C Incineration and open burning of waste	CO ₂	2.6	3.4	10.0	25.0
Greenland	5C Incineration and open burning of waste	CH ₄	2.7	1.9	10.0	50.0
Greenland	5C Incineration and open burning of waste	N ₂ O	0.7	0.6	10.0	100.0
Greenland	5D Wastewater treatment and discharge	N ₂ O	7.2	5.3	30.0	100.0

17.4 Key category analysis

A tier 1 key category analysis (KCA) has been carried out on emissions from Denmark and Greenland. The key category analysis for Denmark is included in Chapter 1.5 and Annex 1, and the key category analysis for Greenland is included in Chapter 16.

The KCA for 1990 and 2020 has been carried out in accordance with the IPCC Guidelines 2006. The KCA is based on data available in CRF and thus slightly more aggregated than the KCA carried out for Denmark. The categorisation

used results in a total of 141 source categories of which 22 are LULUCF categories.

The KCA for Denmark and Greenland includes a total of six different analyses:

- Base year, reporting year and trend,
- Including and excluding LULUCF.

The six different KCA for Denmark and Greenland point out 19-28 key source categories each and a total of 32 different key source categories. The number of key categories in each of the main sectors are Energy 16, Industrial processes and product use 4, Agriculture 5, LULUCF 5 and Waste 2.

The KCA for Denmark and Greenland are shown in Annex 8. An overview for all KCA is given in Table 17.3.

Table 17.3 Key Category Analysis for Denmark and Greenland, overview.

IPCC Source Categories		GHG	Level Tier 1 1990 Excl. LULUCF	Level Tier 1 2020 Excl. LULUCF	Trend Tier 1 1990/1995 - 2020 Excl. LULUCF	Level Tier 1 1990 Incl. LULUCF	Level Tier 1 2020 Incl. LULUCF	Trend Tier 1 1990/1995 - 2020 Incl. LULUCF
Energy	1A1 Energy industries, Liquid Fuels	CO ₂	7	13	10	8	16	11
Energy	1A1 Energy industries, Solid Fuels	CO ₂	1	4	1	1	4	1
Energy	1A1 Energy industries, Gaseous Fuels	CO ₂	10	7	19	12	9	22
Energy	1A1 Energy industries, Other Fuels	CO ₂	19	8	6	22	10	7
Energy	1A2 Manufacturing industries and construction, Liquid Fuels	CO ₂	6	10	5	7	12	6
Energy	1A2 Manufacturing industries and construction, Solid Fuels	CO ₂	12	17	7	14	21	8
Energy	1A2 Manufacturing industries and construction, Gaseous Fuels	CO ₂	13	11		15	13	
Energy	1A2 Manufacturing industries and construction, Other Fuels	CO ₂			22		27	26
Energy	1A4 Other sectors , Liquid Fuels	CO ₂	3	6	2	3	7	2
Energy	1A4 Other sectors , Solid Fuels	CO ₂			15	25		17
Energy	1A4 Other sectors , Gaseous Fuels	CO ₂	11	9		13	11	
Energy	1A4 Other sectors , Other Fuels	CO ₂						
Energy	1A5 Non-specified, Mobile	CO ₂		21			25	
Energy	1A1 Energy industries, Liquid Fuels	CH ₄						
Energy	1A1 Energy industries, Solid Fuels	CH ₄						
Energy	1A1 Energy industries, Gaseous Fuels	CH ₄						
Energy	1A1 Energy industries, Other Fuels	CH ₄						
Energy	1A1 Energy industries, Biomass	CH ₄						
Energy	1A2 Manufacturing industries and construction, Liquid Fuels	CH ₄						
Energy	1A2 Manufacturing industries and construction, Solid Fuels	CH ₄						
Energy	1A2 Manufacturing industries and construction, Gaseous Fuels	CH ₄						
Energy	1A2 Manufacturing industries and construction, Other Fuels	CH ₄						
Energy	1A2 Manufacturing industries and construction, Biomass	CH ₄						
Energy	1A4 Other sectors , Liquid Fuels	CH ₄						
Energy	1A4 Other sectors , Solid Fuels	CH ₄						
Energy	1A4 Other sectors , Gaseous Fuels	CH ₄						
Energy	1A4 Other sectors , Other Fuels	CH ₄						
Energy	1A4 Other sectors , Biomass	CH ₄						
Energy	1A5 Non-specified, Mobile	CH ₄						
Energy	1A1 Energy industries, Liquid Fuels	N ₂ O						
Energy	1A1 Energy industries, Solid Fuels	N ₂ O						
Energy	1A1 Energy industries, Gaseous Fuels	N ₂ O						
Energy	1A1 Energy industries, Other Fuels	N ₂ O						
Energy	1A1 Energy industries, Biomass	N ₂ O						
Energy	1A2 Manufacturing industries and construction, Liquid Fuels	N ₂ O						

IPCC Source Categories		GHG	Level Tier 1 1990 Excl. LULUCF	Level Tier 1 2020 Excl. LULUCF	Trend Tier 1 1990/1995 - 2020 Excl. LULUCF	Level Tier 1 1990 Incl. LULUCF	Level Tier 1 2020 Incl. LULUCF	Trend Tier 1 1990/1995 - 2020 Incl. LULUCF
Energy	1A2 Manufacturing industries and construction, Solid Fuels	N ₂ O						
Energy	1A2 Manufacturing industries and construction, Gaseous Fuels	N ₂ O						
Energy	1A2 Manufacturing industries and construction, Other Fuels	N ₂ O						
Energy	1A2 Manufacturing industries and construction, Biomass	N ₂ O						
Energy	1A4 Other sectors , Liquid Fuels	N ₂ O						
Energy	1A4 Other sectors , Solid Fuels	N ₂ O						
Energy	1A4 Other sectors , Gaseous Fuels	N ₂ O						
Energy	1A4 Other sectors , Other Fuels	N ₂ O						
Energy	1A4 Other sectors , Biomass	N ₂ O						
Energy	1A5 Non-specified, Mobile	N ₂ O						
Energy	1A3. Transport, a Domestic aviation	CO ₂						
Energy	1A3. Transport, a Domestic aviation	CH ₄						
Energy	1A3. Transport, a Domestic aviation	N ₂ O						
Energy	1A3. Transport, b Road transportation	CO ₂	2	1	3	2	1	5
Energy	1A3. Transport, b Road transportation	CH ₄						
Energy	1A3. Transport, b Road transportation	N ₂ O						
Energy	1A3. Transport, c Railways	CO ₂					28	
Energy	1A3. Transport, c Railways	CH ₄						
Energy	1A3. Transport, c Railways	N ₂ O						
Energy	1A3. Transport, d Domestic navigation	CO ₂	17	16	20	20	20	21
Energy	1A3. Transport, d Domestic navigation	CH ₄						
Energy	1A3. Transport, d Domestic navigation	N ₂ O						
Energy	1B Fugitive emissions from fuels, 2a Oil	CO ₂						
Energy	1B Fugitive emissions from fuels, 2a Oil	CH ₄						
Energy	1B Fugitive emissions from fuels, 2a Oil	N ₂ O						
Energy	1B Fugitive emissions from fuels, 2b Natural gas	CO ₂						
Energy	1B Fugitive emissions from fuels, 2b Natural gas	CH ₄						
Energy	1B Fugitive emissions from fuels, 2c Venting gas	CO ₂						
Energy	1B Fugitive emissions from fuels, 2c Venting gas	CH ₄						
Energy	1B Fugitive emissions from fuels, 2c, Flaring	CO ₂				24		25
Energy	1B Fugitive emissions from fuels, 2c, Flaring	CH ₄						
Energy	1B Fugitive emissions from fuels, 2c, Flaring	N ₂ O						
Industrial processes	2A. Mineral industry, 1 Cement production	CO ₂	16	12	12	19	14	16
Industrial processes	2A. Mineral industry, 2 Lime production	CO ₂						
Industrial processes	2A. Mineral industry, 3 Glass production	CO ₂						
Industrial processes	2A. Mineral industry, 4 Other process uses of carbonates	CO ₂						

IPCC Source Categories		GHG	Level Tier 1 1990 Excl. LULUCF	Level Tier 1 2020 Excl. LULUCF	Trend Tier 1 1990/1995 - 2020 Excl. LULUCF	Level Tier 1 1990 Incl. LULUCF	Level Tier 1 2020 Incl. LULUCF	Trend Tier 1 1990/1995 - 2020 Incl. LULUCF
Industrial processes	2B. Chemical Industry, 2 Nitric acid production	N ₂ O	14		8	17		10
Industrial processes	2B. Chemical Industry, 10 Other	CO ₂						
Industrial processes	2C. Metal industry, 1 Iron and steel production	CO ₂						
Industrial processes	2C. Metal industry, 1 Iron and steel production	CH ₄						
Industrial processes	2C. Metal industry, 4 Magnesium production	SF ₆						
Industrial processes	2C. Metal industry, 5 Lead production	CO ₂						
Industrial processes	2D. Non-energy products from fuels and solvent use, 1 Lubricant use	CO ₂						
Industrial processes	2D. Non-energy products from fuels and solvent use, 2 Paraffin wax use	CO ₂						
Industrial processes	2D. Non-energy products from fuels and solvent use, 2 Paraffin wax use	CH ₄						
Industrial processes	2D. Non-energy products from fuels and solvent use, 2 Paraffin wax use	N ₂ O						
Industrial processes	2D. Non-energy products from fuels and solvent use, 3 Other	CO ₂						
Industrial processes	2D. Non-energy products from fuels and solvent use, 3 Other	CH ₄						
Industrial processes	2E. Electronics industry, 5 Other	HFCs						
Industrial processes	2E. Electronics industry, 5 Other	PFCs						
Industrial processes	2F. Product uses as substitutes for ODS, 1 Refrigeration and air conditioning	HFCs		18	17		22	18
Industrial processes	2F. Product uses as substitutes for ODS, 1 Refrigeration and air conditioning	PFCs						
Industrial processes	2F. Product uses as substitutes for ODS, 2 Foam blowing agents	HFCs			21			24
Industrial processes	2F. Product uses as substitutes for ODS, 4 Aerosols	HFCs						
Industrial processes	2G. Other product manufacture and use, 1 Electrical equipment	SF ₆						
Industrial processes	2G. Other product manufacture and use, 2 SF ₆ and PFCs from other product use	SF ₆						
Industrial processes	2G. Other product manufacture and use, 3 N ₂ O from product uses	N ₂ O						
Industrial processes	2G. Other product manufacture and use, 4 Other	CO ₂						
Industrial processes	2G. Other product manufacture and use, 4 Other	CH ₄						
Industrial processes	2G. Other product manufacture and use, 4 Other	N ₂ O						
Agriculture	3A. Enteric fermentation, -	CH ₄	5	3	11	6	3	13
Agriculture	3B. Manure management, -	CH ₄	8	5	13	10	6	20
Agriculture	3B. Manure management, -	N ₂ O	15	14	16	18	18	15
Agriculture	3D. Agricultural soils, -	N ₂ O	4	2	4	4	2	4
Agriculture	3F. Field burning of agricultural residues, -	CH ₄						
Agriculture	3F. Field burning of agricultural residues, -	N ₂ O						
Agriculture	3G. Liming, -	CO ₂	18	20	14	21	24	14
Agriculture	3H. Urea application, -	CO ₂						
Agriculture	3I. Other carbon-containing fertilizers, -	CO ₂						
Waste	5A. Solid waste disposal, -	CH ₄	9	15	9	11	19	9
Waste	5B. Biological treatment of solid waste, 1. Composting	CH ₄						
Waste	5B. Biological treatment of solid waste, 1. Composting	N ₂ O						

IPCC Source Categories		GHG	Level Tier 1 1990 Excl. LULUCF	Level Tier 1 2020 Excl. LULUCF	Trend Tier 1 1990/1995 - 2020 Excl. LULUCF	Level Tier 1 1990 Incl. LULUCF	Level Tier 1 2020 Incl. LULUCF	Trend Tier 1 1990/1995 - 2020 Incl. LULUCF
Waste	5B. Biological treatment of solid waste, 2. Anaerobic digestion at biogas facilities	CH ₄		19	18		23	19
Waste	5C. Incineration and open burning of waste, 1. Waste incineration	CO ₂						
Waste	5C. Incineration and open burning of waste, 1. Waste incineration	CH ₄						
Waste	5C. Incineration and open burning of waste, 1. Waste incineration	N ₂ O						
Waste	5C. Incineration and open burning of waste, 2. Open burning of waste	CO ₂						
Waste	5C. Incineration and open burning of waste, 2. Open burning of waste	CH ₄						
Waste	5C. Incineration and open burning of waste, 2. Open burning of waste	N ₂ O						
Waste	5D. Wastewater treatment and discharge, 1. Domestic wastewater	CH ₄						
Waste	5D. Wastewater treatment and discharge, 1. Domestic wastewater	N ₂ O						
Waste	5D. Wastewater treatment and discharge, 2. Industrial wastewater	N ₂ O						
Waste	5E. Other (please specify), -	CO ₂						
Waste	5E. Other (please specify), -	CH ₄						
LULUCF	4A. Forest land, -	CH ₄						
LULUCF	4A. Forest land, -	N ₂ O						
LULUCF	4A. Forest land, 1. Forest land remaining forest land	CO ₂					17	12
LULUCF	4A. Forest land, 2. Land converted to forest land	CO ₂				16	15	27
LULUCF	4B. Cropland, 1. Cropland remaining cropland	CO ₂				5	5	3
LULUCF	4B. Cropland, 2. Land converted to cropland	CO ₂						
LULUCF	4B. Cropland, -	CH ₄						
LULUCF	4B. Cropland, 2. Land converted to cropland	N ₂ O						
LULUCF	4B. Cropland, Drained organic soils	CO ₂						
LULUCF	4C. Grassland, -	CH ₄						
LULUCF	4C. Grassland, 1. Grassland remaining grassland	CO ₂				9	8	
LULUCF	4C. Grassland, 1. Grassland remaining grassland	N ₂ O						
LULUCF	4C. Grassland, 2. Land converted to grassland	CO ₂						
LULUCF	4C. Grassland, 2. Land converted to grassland	N ₂ O						
LULUCF	4C. Grassland, Drained organic soils	CO ₂						
LULUCF	4D. Wetlands, -	CH ₄						
LULUCF	4D. Wetlands, -	N ₂ O						
LULUCF	4D. Wetlands, 1. Wetlands remaining wetlands	CO ₂						
LULUCF	4D. Wetlands, 2. Land converted to wetlands	CO ₂						
LULUCF	4E. Settlements, 2. Land converted to settlements	CO ₂				23	26	23
LULUCF	4E. Settlements, 2. Land converted to settlements	N ₂ O						
LULUCF	4G. Harvested wood products, -	CO ₂						

17.4.1 Key category analysis for KP-LULUCF

The contribution from Greenland to the KP-LULUCF inventory is miniscule the same categories are therefore identified as key as for the submission from Denmark, see Chapter 11.9 for more information.

17.5 Recalculations

17.5.1 Implications for emission levels

The impact of recalculations in the Greenlandic inventory is insignificant compared to the recalculations in the Danish inventory. Therefore, the explanations and justifications are not repeated in this Chapter. Detailed information on the recalculations in the Danish inventory is provided in Chapter 9 and in the sectoral Chapters 3-7. The recalculations carried out for the Greenlandic inventory are described in Chapter 16.

17.6 Technical description of the aggregation of the emission inventories of Denmark and Greenland

In order to accommodate the request of the ERT of full inclusion of the Greenlandic emission data in the full CRF format, Denmark operates separate installations for Denmark and Greenland (and the Faroe Islands). The country identification codes provided by the UNFCCC secretariat are DNM for Denmark and GRL for Greenland (FRO for the Faroe Islands). Two additional installations are necessary to enable the submission of aggregated submissions under the Kyoto Protocol (Denmark and Greenland) and under UNFCCC (Denmark, Greenland and the Faroe Islands). The country identification codes provided by the UNFCCC secretariat are DKE for the aggregated submission for Denmark and Greenland, and DNK for the UNFCCC submission (Denmark, Greenland and the Faroe Islands).

For the aggregation of the submissions two IT tools are used; 'CRF Aggregator DKE' and 'CRF Aggregator DNK' developed by DCE.

The three main work processes in connection with the aggregation of the submissions are:

- In the CRF Aggregator DKE/DNK the following work processes take place:
 - Aggregation of variables; sum of emissions and activity data, notation keys and comments
 - As input data the xml submission files from the CRF Reporter installations for DNM (Denmark), GRL (Greenland) and FRO (Faroe Islands) are used
 - As output file, a CRF Reporter xml import file is generated. This file is then imported into the CRF Reporter website, DKE (KP-CP1) or DNK (UNFCCC).

17.7 QA/QC of the aggregated submission for Denmark and Greenland

The QA/QC procedures for the Danish inventory are described in Chapter 1.6 and the sectoral chapters. Please refer to Chapter 1.6 for a general description of the QA/QC system, and the structural setup of the Danish QA/QC system for the greenhouse gas inventory. The QA/QC procedures carried out

by Greenlandic authorities for the Greenlandic inventory are described in Chapter 16. The following focuses on the specific QA/QC measures carried out at DCE both on the data (CRF tables and documentation) received from Greenland and the QC checks carried out for the aggregated versions of the inventory for reporting to the Kyoto Protocol and the UNFCCC. The PM's relevant for this are listed in Table 17.5.

Table 17.5 PM's specific to the handling of Greenlandic emission data and the aggregated submissions.

Data Storage level 4	3.Completeness	DS.4.3.3	Check that no sources where methodology exists in the IPCC guidelines are reported as NE by Greenland.
	4.Consistency	DS.4.4.2	Check time series consistency of the reporting by Greenland prior to aggregating the final submissions.
	5.Correctness	DS.4.5.1	Check that the aggregated submissions for Denmark under the Kyoto Protocol and the UNFCCC match the sum of the individual submissions.
		DS.4.5.2	Check that additional information and information related to land-use changes has been correctly aggregated compared to the individual submissions of Denmark and Greenland.
7.Transparency	DS.4.7.2	Perform QA on the documentation report provided by the Government of Greenland.	

Data Storage level 4	3.Completeness	DS.4.3.3	Check that no sources where a methodology exists in the IPCC guidelines or good practice guidance are reported as NE by Greenland
----------------------	----------------	----------	---

A check is made to filter any NE's from the CRF tables. If any greenhouse gas emissions are reported as NE, it is checked whether methodologies exist in the IPCC guidelines or the IPCC good practice guidance. If methodologies do exist, efforts are made to quickly estimate and report emissions. No categories where methodology exists were identified for the submission of Denmark and Greenland.

Data Storage level 4	4.Consistency	DS.4.4.2	Check time series consistency of the reporting of Greenland and the Faroe Islands prior to aggregating the final submissions
----------------------	---------------	----------	--

The time series for all pollutants in the submissions from Greenland and the Faroe Islands are checked at the CRF 3 level for large variations in the time series. Any large variations are explained or corrected in cooperation with the authorities in Greenland and the Faroe Islands.

Data Storage level 4	5.Correctness	DS.4.5.1	Check that the aggregated submissions for Denmark under the Kyoto Protocol and the UNFCCC matches the sum of the individual submissions
----------------------	---------------	----------	---

To ensure that the submission for Denmark under the Kyoto Protocol matches the sum of the submissions of Denmark and Greenland a spreadsheet check has been implemented to ensure complete correctness of the submitted inventory. The same procedure is followed for the submission under the UNFCCC, where it is ensured that the submitted emissions equate to the sum of Den-

mark, Greenland and the Faroe Islands. Special attention is paid to the additional information provided in the CRF, e.g. for the agricultural sector. Certain parameters cannot simply be added, e.g. animal weights. In these cases, a weighted average is reported in the CRF tables.

The check has since the 2012 submission, been extended to also cover area information reported in the KP-LULUCF tables (NIR-2).

Data Storage level 4	5. Correctness	DS.4.5.2	Check that additional information and information related to land-use changes has been correctly aggregated compared to the individual submissions of Denmark and Greenland.
----------------------	----------------	----------	--

The CRF submission for Denmark and Greenland is checked to see if the additional information has been aggregated correctly. The additional information is mainly related to the agricultural and waste sectors.

Data Storage level 4	7. Transparency	DS.4.7.2	Perform QA on the documentation report provided by the Government of Greenland
----------------------	-----------------	----------	--

The documentation report is received by DCE from the Government of Greenland in the early spring every year. The documentation report is included in the NIR as Chapter 16. DCE experts read and provide comments on the report to the Government of Greenland, so that any questions are resolved prior to the UNFCCC reporting deadline of April 15.

Annexes

Annex 1 – Key category analysis

Annex 2 – Assessment of uncertainty

Annex 3 – Other detailed methodological descriptions for individual source or sink categories (where relevant)

Annex 3A – Stationary combustion

Annex 3B – Transport and other mobile sources

Annex 3C – Industrial processes and product use

Annex 3D – Agriculture

Annex 3E – LULUCF

Annex 3F – Waste

Annex 4 – Information on the energy statistics

Annex 5 – Assessment of completeness and (potential) sources and sinks of greenhouse gas emissions and removals excluded

Annex 6 – Additional information to be considered as part of the annual inventory submission and the supplementary information required under Article 7, paragraph 1, of the Kyoto Protocol or other useful reference information

Annex 7 – Methodology applied for the greenhouse gas inventory for the Faroe Islands

Annex 8 – Key category analysis for Denmark and Greenland

Annex 9 – Comparison of fuel data from Eurostat and CRF

Annex 1 - Key category analysis

Description of the methodology used for identifying key categories

Key Category Analysis (KCA) approach 1 and 2 for year 1990 and 2020 for Denmark (excluding Greenland and Faroe Islands) has been carried out in accordance with the IPCC Guidelines (2006). The KCA has been carried out excluding and including the LULUCF sector. An approach 1 KCA has also been worked out for Greenland and for Denmark and Greenland; refer to Chapter 16 and Chapter 17, respectively.

The base year in the analysis is the year 1990 for the greenhouse gases CO₂, CH₄, N₂O and 1995 for the F-gases HFC, PFC and SF₆. The KCA approaches are:

- A quantitative analysis, approach 1 KCA.
- An analysis based on uncertainties, approach 2 KCA.

The level assessment of the approach 1 KCA is a ranking of the source categories in accordance to their relative contribution to the national total of greenhouse gases calculated in CO₂ equivalent units. The level key categories are found from the list of source categories ranked according to their contribution in descending order. Level key categories are those from the top of the list and of which the sum constitutes 95 % of the national total.

The trend assessment of the approach 1 KCA is a ranking of the source categories according to their contribution to the trend of the national total of greenhouse gases, calculated in CO₂ equivalents, from the base year to the latest year. The trend of the source category is calculated relative to that of the national totals and the trend is then weighted with the contribution, according to the level assessment. The ranking is in descending order. As for the level assessment, the cut-off point for the sum of contribution to the trend is 95 % and the source categories from the top of the list to the cut-off line are trend key categories.

In addition, an approach 2 KCA has been carried out to provide additional insight into categories being key sources. The categorisation used is as for the approach 1 analysis and the uncertainties used are approach 1 uncertainties as listed in Annex 2.

The level approach 2 KCA is a ranking of the categories according to their relative contribution to the national total multiplied by the uncertainty of the emission of the category as the combined uncertainty on activity data and on emission factor. Chosen for cut of for key categories in the analysis is 90 %.

The trend approach 2 KCA is a ranking of the categories according to their relative contribution to the trend 1990-2020 of the national total multiplied by the uncertainty of the emission of the category. Chosen for cut of for key categories in the analysis is 90 %.

Since the level KCA is carried out for 1990, 2020 and trend, for data exclusive and inclusive LULUCF and based on approach 1 and approach 2 a total of 12 KCA tables for Denmark (excluding Greenland and Faroe Islands) has been worked out.

In addition, two¹ overview tables based on the Guidebook (2006), Vol. 1, Table 4.4 are shown. The overview tables show summary results of the KCAs for 1990, for 2020, and for the trend 1990-2020.

The inclusion of the LULUCF sector in the level analysis implies that the emissions in this sector are all calculated positive, i.e. the absolute value of removals are included. Note also that according to the Guidebook, the analysis implies that contributions to the trend are all calculated as mathematically positive to be able to perform the ranking.

Emission source categories

The emission source categories are identical to the emission source categories applied in the uncertainty analysis. The KCA is based on 224 emission source categories including 35 LULUCF source categories.

Result of the Key Category Analysis for Denmark

An overview of results of the KCA excluding LULUCF is shown in Table A1-1 and results of the KCA including LULUCF is shown in Table A1-2. The number of key source categories for each of the KCA are shown in Table A1-3.

The 12 different KCA for Denmark point out 22-48 key source categories each and a total of 74 different key source categories. The number of key categories in each of the main sectors is: energy 35, IPPU 4, agriculture 14, LULUCF 16 and waste 5.

Approach 1 point out mainly the large emission sources as key categories and thus CO₂ emission from stationary and mobile combustion are important key categories. Approach 2 point out some of the sources with larger uncertainty rates.

The list below gives an overview of the different KCA for Denmark (not including Greenland and Faroe Islands) that are presented in Table A1-4 – Table A1-15.

Table A1-4 KCA for Denmark, level assessment, base year excl. LULUCF, approach 1.

Table A1-5 KCA for Denmark, level assessment base year incl. LULUCF, approach 1.

Table A1-6 KCA for Denmark, level assessment 2020 excl. LULUCF, approach 1.

Table A1-7 KCA for Denmark, level assessment 2020 incl. LULUCF, approach 1.

Table A1-8 KCA for Denmark, trend assessment 1990-2020 excl. LULUCF, approach 1.

Table A1-9 KCA for Denmark, trend assessment 1990-2020 incl. LULUCF, approach 1.

Table A1-10 KCA for Denmark, level assessment base year excl. LULUCF, approach 2.

Table A1-11 KCA for Denmark, level assessment base year incl. LULUCF, approach 2.

Table A1-12 KCA for Denmark, level assessment 2020 excl. LULUCF, approach 2.

Table A1-13 KCA for Denmark, level assessment 2020 incl. LULUCF, approach 2.

Table A1-14 KCA for Denmark, trend assessment 1990-2020 excl. LULUCF, approach 2.

Table A1-15 KCA for Denmark, trend assessment 1990-2020 incl. LULUCF, approach 2.

¹ Including and excluding LULUCF.

Table A1-1 Summary of KCA for Denmark, level and trend for 1990-2020, excl. LULUCF, approach 1 and approach 2.

IPCC Source Categories (LULUCF excluded)		GHG	Key categories with number according to ranking in analysis					
			Level Approach 1 1990	Level Approach 1 2020	Trend Approach 1 1990-2020	Level Approach 2 1990	Level Approach 2 2020	Trend Approach 2 1990-2020
Energy	1A Stationary combustion, Coal, ETS data, CO ₂	CO ₂		4	3			
Energy	1A Stationary combustion, Coal, no ETS data, CO ₂	CO ₂	1	34	1	15		6
Energy	1A Stationary combustion, BKB, CO ₂	CO ₂						
Energy	1A Stationary combustion, Coke oven coke, CO ₂	CO ₂						
Energy	1A Stationary combustion, Fossil waste, ETS data, CO ₂	CO ₂		6	7			32
Energy	1A Stationary combustion, Fossil waste, no ETS data, CO ₂	CO ₂	20	21	26			
Energy	1A Stationary combustion, Petroleum coke, ETS data, CO ₂	CO ₂		14	11			
Energy	1A Stationary combustion, Petroleum coke, no ETS data, CO ₂	CO ₂	25		24			
Energy	1A Stationary combustion, Residual oil, ETS data, CO ₂	CO ₂		27	21			
Energy	1A Stationary combustion, Residual oil, no ETS data, CO ₂	CO ₂	6		6			
Energy	1A Stationary combustion, Gas oil, CO ₂	CO ₂	3	16	4			24
Energy	1A Stationary combustion, Kerosene, CO ₂	CO ₂	27		23			
Energy	1A Stationary combustion, LPG, CO ₂	CO ₂		32				
Energy	1A1b Stationary combustion, Petroleum refining, Refinery gas, CO ₂	CO ₂	15	11	16			
Energy	1A Stationary combustion, Natural gas, onshore, CO ₂	CO ₂	5	2	5			
Energy	1A1c_ii Stationary combustion, Oil and gas extraction, Off shore gas turbines, Natural gas, CO ₂	CO ₂	23	12	13			
Energy	1A1 Stationary Combustion, Solid fuels, CH ₄	CH ₄						
Energy	1A1 Stationary Combustion, Liquid fuels, CH ₄	CH ₄						
Energy	1A1 Stationary Combustion, not engines, gaseous fuels, CH ₄	CH ₄						
Energy	1A1 Stationary Combustion, Waste, CH ₄	CH ₄						
Energy	1A1 Stationary Combustion, not engines, Biomass, CH ₄	CH ₄						
Energy	1A2 Stationary Combustion, solid fuels, CH ₄	CH ₄						
Energy	1A2 Stationary Combustion, Liquid fuels, CH ₄	CH ₄						
Energy	1A2 Stationary Combustion, not engines, gaseous fuels, CH ₄	CH ₄						
Energy	1A2 Stationary Combustion, Waste, CH ₄	CH ₄						
Energy	1A2 Stationary Combustion, not engines, Biomass, CH ₄	CH ₄						
Energy	1A4 Stationary Combustion, Solid fuels, CH ₄	CH ₄						
Energy	1A4 Stationary Combustion, Liquid fuels, CH ₄	CH ₄						
Energy	1A4 Stationary Combustion, not engines, gaseous fuels, CH ₄	CH ₄						
Energy	1A4 Stationary Combustion, Waste, CH ₄	CH ₄						
Energy	1A4 Stationary Combustion, not engines, not residential wood and not residential/agricultural straw, Biomass, CH ₄	CH ₄						
Energy	1A4b_i Stationary combustion, Residential wood combustion, CH ₄	CH ₄						
Energy	1A4b_i/1A4c_i Stationary Combustion, Residential and agricultural straw combustion, CH ₄	CH ₄						

IPCC Source Categories (LULUCF excluded)		GHG	Key categories with number according to ranking in analysis					
			Level Approach 1 1990	Level Approach 1 2020	Trend Approach 1 1990-2020	Level Approach 2 1990	Level Approach 2 2020	Trend Approach 2 1990-2020
Energy	1A Stationary combustion, Natural gas fuelled engines, gaseous fuels, CH ₄	CH ₄						
Energy	1A Stationary combustion, Biogas fuelled engines, Biomass, CH ₄	CH ₄						
Energy	1A1 Stationary Combustion, Solid fuels, N ₂ O	N ₂ O				19		16
Energy	1A1 Stationary Combustion, Liquid fuels, N ₂ O	N ₂ O						
Energy	1A1 Stationary Combustion, Gaseous fuels, N ₂ O	N ₂ O						
Energy	1A1 Stationary Combustion, Waste, N ₂ O	N ₂ O						33
Energy	1A1 Stationary Combustion, Biomass, N ₂ O	N ₂ O					19	12
Energy	1A2 Stationary Combustion, Solid fuels, N ₂ O	N ₂ O					24	27
Energy	1A2 Stationary Combustion, Liquid fuels, N ₂ O	N ₂ O				17		17
Energy	1A2 Stationary Combustion, Gaseous fuels, N ₂ O	N ₂ O						
Energy	1A2 Stationary Combustion, Waste, N ₂ O	N ₂ O						
Energy	1A2 Stationary Combustion, Biomass, N ₂ O	N ₂ O						
Energy	1A4 Stationary Combustion, Solid fuels, N ₂ O	N ₂ O						
Energy	1A4 Stationary Combustion, Liquid fuels, N ₂ O	N ₂ O						31
Energy	1A4 Stationary Combustion, Gaseous fuels, N ₂ O	N ₂ O						
Energy	1A4 Stationary Combustion, Waste, N ₂ O	N ₂ O						
Energy	1A4 Stationary Combustion, not residential wood and not residential/agricultural straw, Biomass, N ₂ O	N ₂ O						
Energy	1A4b_i Stationary Combustion, Residential wood combustion, N ₂ O	N ₂ O					18	14
Energy	1A4b_i/1A4c_i Stationary Combustion, Residential and agricultural straw combustion, N ₂ O	N ₂ O						
Energy	1.A.2.g Industry (mobile)	CO ₂	24	18	22	20	14	18
Energy	1.A.3.a Civil aviation	CO ₂						
Energy	1.A.3.b Road Transport	CO ₂	2	1	2	14	8	5
Energy	1.A.3.c Railways	CO ₂	30	29				
Energy	1.A.3.d Navigation (large vessels)	CO ₂	18	20				
Energy	1.A.4.a Commercial/Institutional (mobile)	CO ₂		28	28			36
Energy	1.A.4.b Residential (mobile)	CO ₂						
Energy	1.A.4.c ii Agriculture (mobile)	CO ₂	13	13	18	21	16	22
Energy	1.A.4.c ii Forestry (mobile)	CO ₂						
Energy	1.A.4.c iii Fisheries	CO ₂	19	25				
Energy	1.A.5.b Other (military)	CO ₂						
Energy	1.A.5.b Other (small boats)	CO ₂		33				
Energy	1.A.2.g Industry (mobile)	CH ₄						
Energy	1.A.3.a Civil aviation	CH ₄						
Energy	1.A.3.b Road Transport	CH ₄						
Energy	1.A.3.c Railways	CH ₄						

IPCC Source Categories (LULUCF excluded)		GHG	Key categories with number according to ranking in analysis					
			Level Approach 1 1990	Level Approach 1 2020	Trend Approach 1 1990-2020	Level Approach 2 1990	Level Approach 2 2020	Trend Approach 2 1990-2020
Energy	1.A.3.d Navigation (large vessels)	CH ₄						
Energy	1.A.4.a Commercial/Institutional (mobile)	CH ₄						
Energy	1.A.4.b Residential (mobile)	CH ₄						
Energy	1.A.4.c ii Agriculture (mobile)	CH ₄						
Energy	1.A.4.c ii Forestry (mobile)	CH ₄						
Energy	1.A.4.c iii Fisheries	CH ₄						
Energy	1.A.5.b Other (military)	CH ₄						
Energy	1.A.5.b Other (small boats)	CH ₄						
Energy	1.A.2.g Industry (mobile)	N ₂ O						34
Energy	1.A.3.a Civil aviation	N ₂ O						
Energy	1.A.3.b Road Transport	N ₂ O						
Energy	1.A.3.c Railways	N ₂ O						
Energy	1.A.3.d Navigation (large vessels)	N ₂ O						
Energy	1.A.4.a Commercial/Institutional (mobile)	N ₂ O						
Energy	1.A.4.b Residential (mobile)	N ₂ O						
Energy	1.A.4.c ii Agriculture (mobile)	N ₂ O					22	29
Energy	1.A.4.c ii Forestry (mobile)	N ₂ O						
Energy	1.A.4.c iii Fisheries	N ₂ O						
Energy	1.A.5.b Other (military)	N ₂ O						
Energy	1.A.5.b Other (small boats)	N ₂ O						
Energy	1.B.2.a.1 Exploration	CO ₂						
Energy	1.B.2.a.2 Production	CO ₂						
Energy	1.B.2.a.4 Refining/storage	CO ₂						
Energy	1.B.2.b.1 Exploration	CO ₂						
Energy	1.B.2.b.2 Production	CO ₂						
Energy	1.B.2.b.4 Transmission and storage	CO ₂						
Energy	1.B.2.b.5 Distribution	CO ₂						
Energy	1.B.2.c.1.ii Venting	CO ₂						
Energy	1.B.2.c.2.i Flaring, oil	CO ₂						
Energy	1.B.2.c.2.ii Flaring, gas	CO ₂						
Energy	1.B.2.c.2.iii Flaring, combined	CO ₂	28					
Energy	1.B.2.a.1 Exploration	CH ₄						
Energy	1.B.2.a.2 Production	CH ₄						
Energy	1.B.2.a.3 Transport	CH ₄						
Energy	1.B.2.a.4 Refining/storage	CH ₄						
Energy	1.B.2.b.1 Exploration	CH ₄						
Energy	1.B.2.b.2 Production	CH ₄						

IPCC Source Categories (LULUCF excluded)		GHG	Key categories with number according to ranking in analysis						
			Level Approach 1 1990	Level Approach 1 2020	Trend Approach 1 1990-2020	Level Approach 2 1990	Level Approach 2 2020	Trend Approach 2 1990-2020	
Energy	1.B.2.b.4 Transmission and storage	CH ₄							
Energy	1.B.2.b.5 Distribution	CH ₄							
Energy	1.B.2.c.1.ii Venting	CH ₄							
Energy	1.B.2.c.2.i Flaring, oil	CH ₄							
Energy	1.B.2.c.2.ii Flaring, gas	CH ₄							
Energy	1.B.2.c.2.iii Flaring, combined	CH ₄							
Energy	1.B.2.a.1 Exploration, oil	N ₂ O							
Energy	1.B.2.c.2.i Flaring, oil	N ₂ O							
Energy	1.B.2.c.2.ii Flaring, gas	N ₂ O							
Energy	1.B.2.c.2.iii Flaring, combined	N ₂ O				13	15	20	
IPPU	2A1 Cement production	CO ₂	12	7	10				
IPPU	2A2 Lime production	CO ₂							
IPPU	2A3 Glass production	CO ₂							
IPPU	2A4a Ceramics	CO ₂							
IPPU	2A4b Other uses of soda ash	CO ₂							
IPPU	2A4d Other process uses of carbonates	CO ₂							
IPPU	2B10 Production of catalysts	CO ₂							
IPPU	2C1a Steel	CO ₂							
IPPU	2C5 Lead production	CO ₂							
IPPU	2D1 Lubricant use	CO ₂							
IPPU	2D2 Paraffin wax use	CO ₂							
IPPU	Paint Application	CO ₂							
IPPU	Degreasing, dry cleaning and electronics	CO ₂							
IPPU	Chemical products manufacturing or processing	CO ₂							
IPPU	Other use of solvents and related activities	CO ₂							
IPPU	Printing industry	CO ₂							
IPPU	Domestic solvent use (other than paint application)	CO ₂							
IPPU	2D3 Road paving with asphalt	CO ₂							
IPPU	2D3 Asphalt roofing	CO ₂							
IPPU	2D3 Urea based catalysts	CO ₂							
IPPU	2G4 Fireworks	CO ₂							
IPPU	2D2 Paraffin wax use	CH ₄							
IPPU	2D3 Road paving with asphalt	CH ₄							
IPPU	2G4 Fireworks	CH ₄							
IPPU	2G4 Tobacco	CH ₄							
IPPU	2G4 Charcoal	CH ₄							
IPPU	2B2 Nitric acid production	N ₂ O	10		12	18		15	

IPCC Source Categories (LULUCF excluded)		GHG	Key categories with number according to ranking in analysis					
			Level Approach 1 1990	Level Approach 1 2020	Trend Approach 1 1990-2020	Level Approach 2 1990	Level Approach 2 2020	Trend Approach 2 1990-2020
IPPU	2D2 Paraffin wax use	N ₂ O						
IPPU	2G3a Medical application of N ₂ O	N ₂ O						
IPPU	2G3b N ₂ O as propellant for pressure and aerosol products	N ₂ O						
IPPU	2G4 Fireworks	N ₂ O						
IPPU	2G4 Tobacco	N ₂ O						
IPPU	2G4 Charcoal	N ₂ O						
IPPU	2E Electronics industry	HFCs						
IPPU	2F1 Refrigeration and air conditioning	HFCs		23	19		20	13
IPPU	2F2 Foam blowing agents	HFCs			25			26
IPPU	2F4 Aerosols	HFCs						
IPPU	2E Electronics industry	PFCs						
IPPU	2F1 Refrigeration and air conditioning	PFCs						
IPPU	2C4 Magnesium production	SF ₆						
IPPU	2G1 Electrical equipment	SF ₆						
IPPU	2G2 SF6 and PFCs from other product use	SF ₆						
Agriculture	3A Enteric Fermentation	CH ₄	4	3	8	9	7	7
Agriculture	3B Manure Management	CH ₄	8	5	9	16	12	8
Agriculture	3F Field Burning of Agricultural Residues	CH ₄						
Agriculture	3B Manure Management	N ₂ O	16	17		10	10	19
Agriculture	3B5 Atmospheric deposition	N ₂ O				22	21	
Agriculture	3Da1 Inorganic N fertilizer	N ₂ O	7	8		1	1	9
Agriculture	3Da2a Animal manure applied to soils	N ₂ O	11	9	15	2	2	2
Agriculture	3Da2b Sewage sludge applied to soils	N ₂ O						
Agriculture	3Da2c Other organic fertilizer applied to soils	N ₂ O						25
Agriculture	3Da3 Urine and dung deposited by grazing animals	N ₂ O	29	31		8	11	
Agriculture	3Da4 Crop Residues	N ₂ O	17	10	14	4	3	1
Agriculture	3Da5 Mineralization	N ₂ O				11	17	11
Agriculture	3Da6 Cultivation of organic soils	N ₂ O	14	15	27	3	4	4
Agriculture	3Db1 Atmospheric deposition	N ₂ O	26	30		5	6	10
Agriculture	3Db2 Leaching	N ₂ O	22	22		6	5	
Agriculture	3F Field Burning of Agricultural Residues	N ₂ O						
Agriculture	3G Liming	CO ₂	21	26		12	13	21
Agriculture	3H Urea applicaton	CO ₂						
Agriculture	3I Other carbon-containing fertilizers	CO ₂						
Waste	5.E Accidental fires	CO ₂						
Waste	5.A Solid waste disposal	CH ₄	9	19	17	7	9	3
Waste	5.B.1 Composting	CH ₄					23	23

IPCC Source Categories (LULUCF excluded)		GHG	Key categories with number according to ranking in analysis						
			Level	Level	Trend	Level	Level	Trend	
			Approach 1 1990	Approach 1 2020	Approach 1 1990-2020	Approach 2 1990	Approach 2 2020	Approach 2 1990-2020	
Waste	5.B.2. Anaerobic digestion at biogas facilities	CH ₄		24	20				30
Waste	5.C.1 Incineration of corpses	CH ₄							
Waste	5.C.2 Incineration of carcasses	CH ₄							
Waste	5.D.1 Domestic wastewater	CH ₄							
Waste	5.E Accidental fires	CH ₄							
Waste	5.B.1 Composting	N ₂ O							28
Waste	5.C.1 Incineration of corpses	N ₂ O							
Waste	5.C.2 Incineration of carcasses	N ₂ O							
Waste	5.D.1 Domestic wastewater	N ₂ O		35					35
Waste	5.D.2 Industrial wastewater	N ₂ O							

Table A1-2 Summary of KCA for Denmark, level and trend for 1990-2020, incl. LULUCF, approach 1 and approach 2.

IPCC Source Categories (LULUCF included)		GHG	Key categories with number according to ranking in analysis					
			Level Approach 1 1990	Level Approach 1 2020	Trend Approach 1 1990-2020	Level Approach 2 1990	Level Approach 2 2020	Trend Approach 2 1990-2020
Energy	1A Stationary combustion, Coal, ETS data, CO ₂	CO ₂		4	3			
Energy	1A Stationary combustion, Coal, no ETS data, CO ₂	CO ₂	1	41	1	18		10
Energy	1A Stationary combustion, BKB, CO ₂	CO ₂						
Energy	1A Stationary combustion, Coke oven coke, CO ₂	CO ₂						
Energy	1A Stationary combustion, Fossil waste, ETS data, CO ₂	CO ₂		8	7			38
Energy	1A Stationary combustion, Fossil waste, no ETS data, CO ₂	CO ₂	24	25	30			
Energy	1A Stationary combustion, Petroleum coke, ETS data, CO ₂	CO ₂		18	12			
Energy	1A Stationary combustion, Petroleum coke, no ETS data, CO ₂	CO ₂	30		29			
Energy	1A Stationary combustion, Residual oil, ETS data, CO ₂	CO ₂		32	27			
Energy	1A Stationary combustion, Residual oil, no ETS data, CO ₂	CO ₂	7		6			
Energy	1A Stationary combustion, Gas oil, CO ₂	CO ₂	3	20	4	27		28
Energy	1A Stationary combustion, Kerosene, CO ₂	CO ₂	32		28			
Energy	1A Stationary combustion, LPG, CO ₂	CO ₂		39				
Energy	1A1b Stationary combustion, Petroleum refining, Refinery gas, CO ₂	CO ₂	19	14	19			
Energy	1A Stationary combustion, Natural gas, onshore, CO ₂	CO ₂	6	2	5			
Energy	1A1c_ii Stationary combustion, Oil and gas extraction, Off shore gas turbines, Natural gas, CO ₂	CO ₂	27	15	16			
Energy	1A1 Stationary Combustion, Solid fuels, CH ₄	CH ₄						
Energy	1A1 Stationary Combustion, Liquid fuels, CH ₄	CH ₄						
Energy	1A1 Stationary Combustion, not engines, gaseous fuels, CH ₄	CH ₄						
Energy	1A1 Stationary Combustion, Waste, CH ₄	CH ₄						
Energy	1A1 Stationary Combustion, not engines, Biomass, CH ₄	CH ₄						
Energy	1A2 Stationary Combustion, solid fuels, CH ₄	CH ₄						
Energy	1A2 Stationary Combustion, Liquid fuels, CH ₄	CH ₄						
Energy	1A2 Stationary Combustion, not engines, gaseous fuels, CH ₄	CH ₄						
Energy	1A2 Stationary Combustion, Waste, CH ₄	CH ₄						
Energy	1A2 Stationary Combustion, not engines, Biomass, CH ₄	CH ₄						
Energy	1A4 Stationary Combustion, Solid fuels, CH ₄	CH ₄						
Energy	1A4 Stationary Combustion, Liquid fuels, CH ₄	CH ₄						
Energy	1A4 Stationary Combustion, not engines, gaseous fuels, CH ₄	CH ₄						
Energy	1A4 Stationary Combustion, Waste, CH ₄	CH ₄						
Energy	1A4 Stationary Combustion, not engines, not residential wood and not residential/agricultural straw, Biomass, CH ₄	CH ₄						
Energy	1A4b_i Stationary combustion, Residential wood combustion, CH ₄	CH ₄						
Energy	1A4b_i/1A4c_i Stationary Combustion, Residential and agricultural straw combustion, CH ₄	CH ₄						

IPCC Source Categories (LULUCF included)		GHG	Key categories with number according to ranking in analysis					
			Level Approach 1 1990	Level Approach 1 2020	Trend Approach 1 1990-2020	Level Approach 2 1990	Level Approach 2 2020	Trend Approach 2 1990-2020
Energy	1A Stationary combustion, Natural gas fuelled engines, gaseous fuels, CH ₄	CH ₄						
Energy	1A Stationary combustion, Biogas fuelled engines, Biomass, CH ₄	CH ₄						
Energy	1A1 Stationary Combustion, Solid fuels, N ₂ O	N ₂ O				23		19
Energy	1A1 Stationary Combustion, Liquid fuels, N ₂ O	N ₂ O						
Energy	1A1 Stationary Combustion, Gaseous fuels, N ₂ O	N ₂ O						
Energy	1A1 Stationary Combustion, Waste, N ₂ O	N ₂ O						40
Energy	1A1 Stationary Combustion, Biomass, N ₂ O	N ₂ O					21	14
Energy	1A2 Stationary Combustion, Solid fuels, N ₂ O	N ₂ O					32	30
Energy	1A2 Stationary Combustion, Liquid fuels, N ₂ O	N ₂ O				21		21
Energy	1A2 Stationary Combustion, Gaseous fuels, N ₂ O	N ₂ O						
Energy	1A2 Stationary Combustion, Waste N ₂ O	N ₂ O						
Energy	1A2 Stationary Combustion, Biomass, N ₂ O	N ₂ O						
Energy	1A4 Stationary Combustion, Solid fuels, N ₂ O	N ₂ O						
Energy	1A4 Stationary Combustion, Liquid fuels, N ₂ O	N ₂ O						36
Energy	1A4 Stationary Combustion, Gaseous fuels N ₂ O	N ₂ O						
Energy	1A4 Stationary Combustion, Waste, N ₂ O	N ₂ O						
Energy	1A4 Stationary Combustion, not residential wood and not residential/agricultural straw, Biomass, N ₂ O	N ₂ O						
Energy	1A4b_i Stationary Combustion, Residential wood combustion, N ₂ O	N ₂ O					20	16
Energy	1A4b_i/1A4c_i Stationary Combustion, Residential and agricultural straw combustion, N ₂ O	N ₂ O						
Energy	1.A.2.g Industry (mobile)	CO ₂	28	22	26	24	16	22
Energy	1.A.3.a Civil aviation	CO ₂	37					
Energy	1.A.3.b Road Transport	CO ₂	2	1	2	17	10	7
Energy	1.A.3.c Railways	CO ₂	35	34				
Energy	1.A.3.d Navigation (large vessels)	CO ₂	22	24				
Energy	1.A.4.a Commercial/Institutional (mobile)	CO ₂		33	37			48
Energy	1.A.4.b Residential (mobile)	CO ₂						
Energy	1.A.4.c ii Agriculture (mobile)	CO ₂	17	17	21	25	18	25
Energy	1.A.4.c ii Forestry (mobile)	CO ₂						
Energy	1.A.4.c iii Fisheries	CO ₂	23	30	40			
Energy	1.A.5.b Other (military)	CO ₂						
Energy	1.A.5.b Other (small boats)	CO ₂		40				
Energy	1.A.2.g Industry (mobile)	CH ₄						
Energy	1.A.3.a Civil aviation	CH ₄						
Energy	1.A.3.b Road Transport	CH ₄						
Energy	1.A.3.c Railways	CH ₄						

IPCC Source Categories (LULUCF included)		GHG	Key categories with number according to ranking in analysis						
			Level Approach 1 1990	Level Approach 1 2020	Trend Approach 1 1990-2020	Level Approach 2 1990	Level Approach 2 2020	Trend Approach 2 1990-2020	
Energy	1.A.3.d Navigation (large vessels)	CH ₄							
Energy	1.A.4.a Commercial/Institutional (mobile)	CH ₄							
Energy	1.A.4.b Residential (mobile)	CH ₄							
Energy	1.A.4.c ii Agriculture (mobile)	CH ₄							
Energy	1.A.4.c ii Forestry (mobile)	CH ₄							
Energy	1.A.4.c iii Fisheries	CH ₄							
Energy	1.A.5.b Other (military)	CH ₄							
Energy	1.A.5.b Other (small boats)	CH ₄							
Energy	1.A.2.g Industry (mobile)	N ₂ O							42
Energy	1.A.3.a Civil aviation	N ₂ O							
Energy	1.A.3.b Road Transport	N ₂ O		45					
Energy	1.A.3.c Railways	N ₂ O							
Energy	1.A.3.d Navigation (large vessels)	N ₂ O							
Energy	1.A.4.a Commercial/Institutional (mobile)	N ₂ O							
Energy	1.A.4.b Residential (mobile)	N ₂ O							
Energy	1.A.4.c ii Agriculture (mobile)	N ₂ O						26	33
Energy	1.A.4.c ii Forestry (mobile)	N ₂ O							
Energy	1.A.4.c iii Fisheries	N ₂ O							
Energy	1.A.5.b Other (military)	N ₂ O							
Energy	1.A.5.b Other (small boats)	N ₂ O							
Energy	1.B.2.a.1 Exploration	CO ₂							
Energy	1.B.2.a.2 Production	CO ₂							
Energy	1.B.2.a.4 Refining/storage	CO ₂							
Energy	1.B.2.b.1 Exploration	CO ₂							
Energy	1.B.2.b.2 Production	CO ₂							
Energy	1.B.2.b.4 Transmission and storage	CO ₂							
Energy	1.B.2.b.5 Distribution	CO ₂							
Energy	1.B.2.c.1.ii Venting	CO ₂							
Energy	1.B.2.c.2.i Flaring, oil	CO ₂							
Energy	1.B.2.c.2.ii Flaring, gas	CO ₂							
Energy	1.B.2.c.2.iii Flaring, combined	CO ₂	33						
Energy	1.B.2.a.1 Exploration	CH ₄							
Energy	1.B.2.a.2 Production	CH ₄							
Energy	1.B.2.a.3 Transport	CH ₄							
Energy	1.B.2.a.4 Refining/storage	CH ₄							
Energy	1.B.2.b.1 Exploration	CH ₄							
Energy	1.B.2.b.2 Production	CH ₄							

IPCC Source Categories (LULUCF included)		GHG	Key categories with number according to ranking in analysis							
			Level	Level	Trend	Level	Level	Trend		
			Approach 1 1990	Approach 1 2020	Approach 1 1990-2020	Approach 2 1990	Approach 2 2020	Approach 2 1990-2020		
Energy	1.B.2.b.4 Transmission and storage	CH ₄								
Energy	1.B.2.b.5 Distribution	CH ₄								
Energy	1.B.2.c.1.ii Venting	CH ₄								
Energy	1.B.2.c.2.i Flaring, oil	CH ₄								
Energy	1.B.2.c.2.ii Flaring, gas	CH ₄								
Energy	1.B.2.c.2.iii Flaring, combined	CH ₄								
Energy	1.B.2.a.1 Exploration, oil	N ₂ O								
Energy	1.B.2.c.2.i Flaring, oil	N ₂ O								
Energy	1.B.2.c.2.ii Flaring, gas	N ₂ O								
Energy	1.B.2.c.2.iii Flaring, combined	N ₂ O					16	17		24
IPPU	2A1 Cement production	CO ₂	16	9	11					
IPPU	2A2 Lime production	CO ₂								
IPPU	2A3 Glass production	CO ₂								
IPPU	2A4a Ceramics	CO ₂								
IPPU	2A4b Other uses of soda ash	CO ₂								
IPPU	2A4d Other process uses of carbonates	CO ₂								
IPPU	2B10 Production of catalysts	CO ₂								
IPPU	2C1a Steel	CO ₂								
IPPU	2C5 Lead production	CO ₂								
IPPU	2D1 Lubricant use	CO ₂								
IPPU	2D2 Paraffin wax use	CO ₂								
IPPU	Paint Application	CO ₂								
IPPU	Degreasing, dry cleaning and electronics	CO ₂								
IPPU	Chemical products manufacturing or processing	CO ₂								
IPPU	Other use of solvents and related activities	CO ₂								
IPPU	Printing industry	CO ₂								
IPPU	Domestic solvent use (other than paint application)	CO ₂								
IPPU	2D3 Road paving with asphalt	CO ₂								
IPPU	2D3 Asphalt roofing	CO ₂								
IPPU	2D3 Urea based catalysts	CO ₂								
IPPU	2G4 Fireworks	CO ₂								
IPPU	2D2 Paraffin wax use	CH ₄								
IPPU	2D3 Road paving with asphalt	CH ₄								
IPPU	2G4 Fireworks	CH ₄								
IPPU	2G4 Tobacco	CH ₄								
IPPU	2G4 Charcoal	CH ₄								
IPPU	2B2 Nitric acid production	N ₂ O	13		15		22			17

IPCC Source Categories (LULUCF included)		GHG	Key categories with number according to ranking in analysis					
			Level Approach 1 1990	Level Approach 1 2020	Trend Approach 1 1990-2020	Level Approach 2 1990	Level Approach 2 2020	Trend Approach 2 1990-2020
IPPU	2D2 Paraffin wax use	N ₂ O						
IPPU	2G3a Medical application of N ₂ O	N ₂ O						
IPPU	2G3b N ₂ O as propellant for pressure and aerosol products	N ₂ O						
IPPU	2G4 Fireworks	N ₂ O						
IPPU	2G4 Tobacco	N ₂ O						
IPPU	2G4 Charcoal	N ₂ O						
IPPU	2E Electronics industry	HFCs						
IPPU	2F1 Refrigeration and air conditioning	HFCs		27	22		22	15
IPPU	2F2 Foam blowing agents	HFCs	38		33			31
IPPU	2F4 Aerosols	HFCs						
IPPU	2E Electronics industry	PFCs						
IPPU	2F1 Refrigeration and air conditioning	PFCs						
IPPU	2C4 Magnesium production	SF ₆						
IPPU	2G1 Electrical equipment	SF ₆						
IPPU	2G2 SF ₆ and PFCs from other product use	SF ₆						
Agriculture	3A Enteric Fermentation	CH ₄	4	3	8	11	9	9
Agriculture	3B Manure Management	CH ₄	10	6	9	19	14	11
Agriculture	3F Field Burning of Agricultural Residues	CH ₄						
Agriculture	3B Manure Management	N ₂ O	20	21	38	12	12	20
Agriculture	3B5 Atmospheric deposition	N ₂ O		44		26	25	
Agriculture	3Da1 Inorganic N fertilizer	N ₂ O	9	11	39	1	1	8
Agriculture	3Da2a Animal manure applied to soils	N ₂ O	14	12	18	2	2	2
Agriculture	3Da2b Sewage sludge applied to soils	N ₂ O						
Agriculture	3Da2c Other organic fertilizer applied to soils	N ₂ O					34	29
Agriculture	3Da3 Urine and dung deposited by grazing animals	N ₂ O	34	37		10	13	
Agriculture	3Da4 Crop Residues	N ₂ O	21	13	17	4	3	1
Agriculture	3Da5 Mineralization	N ₂ O	39			14	19	13
Agriculture	3Da6 Cultivation of organic soils	N ₂ O	18	19	31	3	4	4
Agriculture	3Db1 Atmospheric deposition	N ₂ O	31	36		6	8	12
Agriculture	3Db2 Leaching	N ₂ O	26	26		7	6	37
Agriculture	3F Field Burning of Agricultural Residues	N ₂ O						
Agriculture	3G Liming	CO ₂	25	31		15	15	26
Agriculture	3H Urea applicaton	CO ₂						
Agriculture	3I Other carbon-containing fertilizers	CO ₂						
LULUCF	4.A.1 Forest land remaining forest land, Living biomass	CO ₂	36	28				
LULUCF	4.A.1 Forest land remaining forest land, Dead organic matter	CO ₂		16	13			45
LULUCF	4.A.1 Forest land remaining forest land, Mineral soils	CO ₂						

IPCC Source Categories (LULUCF included)		GHG	Key categories with number according to ranking in analysis					
			Level	Level	Trend	Level	Level	Trend
			Approach 1 1990	Approach 1 2020	Approach 1 1990-2020	Approach 2 1990	Approach 2 2020	Approach 2 1990-2020
LULUCF	4.A.1 Forest land remaining forest land, Organic soils	CO ₂		46				
LULUCF	4.A.2 Land converted to forest land	CO ₂	12	10	23	28	23	46
LULUCF	4.B.1 Cropland remaining cropland, Living biomass	CO ₂		38	36			
LULUCF	4.B.1 Cropland remaining cropland, Mineral soils	CO ₂	15		14	13	31	3
LULUCF	4.B.1 Cropland remaining cropland, Organic soils	CO ₂	5	5	25	5	5	18
LULUCF	4.B.2 Forest land converted to cropland	CO ₂		47	34			34
LULUCF	4.B.2 Other land uses converted to cropland	CO ₂			41			41
LULUCF	4(II) Cropland on organic soils	CO ₂						
LULUCF	4.C.1 Grassland remaining grassland, Living biomass	CO ₂		43	32			
LULUCF	4.C.1 Grassland remaining grassland, Organic soils	CO ₂	8	7	10	9	7	6
LULUCF	4.C.2 Forest land converted to grassland	CO ₂						
LULUCF	4.C.2 Other land uses converted to grassland	CO ₂						
LULUCF	4(II) Grassland on organic soils	CO ₂						
LULUCF	4.D.1.1 Peat extraction remaining peat extraction	CO ₂						47
LULUCF	4.D.1.2 Flooded land remaining flooded land	CO ₂						
LULUCF	4.D.2. Land converted to wetlands	CO ₂						
LULUCF	4.E.2 Forest land converted to settlements	CO ₂						
LULUCF	4.E.2 Other land uses converted to settlements	CO ₂	29	35		20	24	39
LULUCF	4.G Harvested wood products	CO ₂		48	35		28	23
LULUCF	4(II) Cropland on organic soils	CH ₄					30	
LULUCF	4(II) Grassland on organic soils	CH ₄					27	43
LULUCF	4(II) A. Forest land, organic soils	CH ₄						
LULUCF	4(II) Land converted to wetlands	CH ₄						
LULUCF	4(II) Peatland	CH ₄						
LULUCF	4(V) Biomass Burning	CH ₄						
LULUCF	4(III) Mineralization/immobilization, Forest land	N ₂ O						
LULUCF	4(III) Mineralization/immobilization, Cropland	N ₂ O						
LULUCF	4(III) Mineralization/immobilization, Grassland	N ₂ O						
LULUCF	4(III) Mineralization/immobilization, Land converted to Settlements	N ₂ O						
LULUCF	4(V) Biomass burning	N ₂ O						
LULUCF	4(II) Drainage and rewetting, Forest soils	N ₂ O						
LULUCF	4(II) Peat extraction remaining peat extraction	N ₂ O						
Waste	5.E Accidental fires	CO ₂						
Waste	5.A Solid waste disposal	CH ₄	11	23	20	8	11	5
Waste	5.B.1 Composting	CH ₄					29	27
Waste	5.B.2. Anaerobic digestion at biogas facilities	CH ₄		29	24			35
Waste	5.C.1 Incineration of corpses	CH ₄						

IPCC Source Categories (LULUCF included)		GHG	Key categories with number according to ranking in analysis					
			Level Approach 1 1990	Level Approach 1 2020	Trend Approach 1 1990-2020	Level Approach 2 1990	Level Approach 2 2020	Trend Approach 2 1990-2020
Waste	5.C.2 Incineration of carcasses	CH ₄						
Waste	5.D.1 Domestic wastewater	CH ₄						
Waste	5.E Accidental fires	CH ₄						
Waste	5.B.1 Composting	N ₂ O						32
Waste	5.C.1 Incineration of corpses	N ₂ O						
Waste	5.C.2 Incineration of carcasses	N ₂ O						
Waste	5.D.1 Domestic wastewater	N ₂ O		42			33	44
Waste	5.D.2 Industrial wastewater	N ₂ O						

Table A1-3 Summary of KCA for Denmark, number of key source categories in each of the KCA.

	Level Approach 1 1990	Level Approach 1 2020	Trend Approach 1 1990-2020	Level Approach 2 1990	Level Approach 2 2020	Trend Approach 2 1990-2020
Excluding LULUCF	30	35	28	22	24	36
Including LULUCF	39	48	41	28	34	48

Table A1-4 KCA for Denmark, level assessment, base year excl. LULUCF, approach 1.
This table is available at: <https://envs.au.dk/en/faglige-omraader/luffforurening-udledninger-og-effekter/udledning-af-luffforurening/greenhouse-gases/supporting-documentation>

Table A1-5 KCA for Denmark, level assessment base year incl. LULUCF, approach 1.
This table is available at: <https://envs.au.dk/en/faglige-omraader/luffforurening-udledninger-og-effekter/udledning-af-luffforurening/greenhouse-gases/supporting-documentation>

Table A1-6 KCA for Denmark, level assessment 2020 excl. LULUCF, approach 1.
This table is available at: <https://envs.au.dk/en/faglige-omraader/luffforurening-udledninger-og-effekter/udledning-af-luffforurening/greenhouse-gases/supporting-documentation>

Table A1-7 KCA for Denmark, level assessment 2020 incl. LULUCF, approach 1.
This table is available at: <https://envs.au.dk/en/faglige-omraader/luffforurening-udledninger-og-effekter/udledning-af-luffforurening/greenhouse-gases/supporting-documentation>

Table A1-8 KCA for Denmark, trend assessment 1990-2020 excl. LULUCF, approach 1.
This table is available at: <https://envs.au.dk/en/faglige-omraader/luffforurening-udledninger-og-effekter/udledning-af-luffforurening/greenhouse-gases/supporting-documentation>

Table A1-9 KCA for Denmark, trend assessment 1990-2020 incl. LULUCF, approach 1.
This table is available at: <https://envs.au.dk/en/faglige-omraader/luffforurening-udledninger-og-effekter/udledning-af-luffforurening/greenhouse-gases/supporting-documentation>

Table A1-10 KCA for Denmark, level assessment base year excl. LULUCF, approach 2.
This table is available at: <https://envs.au.dk/en/faglige-omraader/luffforurening-udledninger-og-effekter/udledning-af-luffforurening/greenhouse-gases/supporting-documentation>

Table A1-11 KCA for Denmark, level assessment base year incl. LULUCF, approach 2.
This table is available at: <https://envs.au.dk/en/faglige-omraader/luffforurening-udledninger-og-effekter/udledning-af-luffforurening/greenhouse-gases/supporting-documentation>

Table A1-12 KCA for Denmark, level assessment 2020 excl. LULUCF, approach 2.
This table is available at: <https://envs.au.dk/en/faglige-omraader/luffforurening-udledninger-og-effekter/udledning-af-luffforurening/greenhouse-gases/supporting-documentation>

Table A1-13 KCA for Denmark, level assessment 2020 incl. LULUCF, approach 2.

This table is available at: <https://envs.au.dk/en/faglige-omraader/luffforurening-udledninger-og-effekter/udledning-af-luffforurening/greenhouse-gases/supporting-documentation>

Table A1-14 KCA for Denmark, trend assessment 1990-2020 excl. LULUCF, approach 2.

This table is available at: <https://envs.au.dk/en/faglige-omraader/luffforurening-udledninger-og-effekter/udledning-af-luffforurening/greenhouse-gases/supporting-documentation>

Table A1-15 KCA for Denmark, trend assessment 1990-2020 incl. LULUCF, approach 2.

This table is available at: <https://envs.au.dk/en/faglige-omraader/luffforurening-udledninger-og-effekter/udledning-af-luffforurening/greenhouse-gases/supporting-documentation>

Annex 2 - Assessment of uncertainty

Description of methodology used for identifying uncertainties

For the inventory of Denmark, the uncertainties are estimated using Approach 1 of the 2006 IPCC Guidelines.

More information and the results are provided in Chapter 1.7.

The underlying table, corresponding to Table 3.3 of volume 1 of the 2006 IPCC Guidelines, is very large and not suitable for incorporation in a text document. The table in Excel format can be found at

<https://envs.au.dk/en/research-areas/air-pollution-emissions-and-effects/air-emissions/greenhouse-gases/supporting-documentation/>

Annex 3 - Other detailed methodological descriptions for individual source or sink categories (where relevant)

Annex 3A - Stationary Combustion

Annex 3B - Transport and other mobile sources

Annex 3C - Industrial processes and product use

Annex 3D - Agriculture

Annex 3E - LULUCF

Annex 3F - Waste

Annex 3A - Stationary combustion

Annex 3A-1:	Correspondence list between SNAP and CRF source categories
Annex 3A-2:	Fuel rate
Annex 3A-3:	Default Lower Calorific Value (LCV) of fuels and fuel correspondence list
Annex 3A-4:	Emission factors
Annex 3A-5:	Large point sources
Annex 3A-6:	Adjustment of CO ₂ emission
Annex 3A-7:	Uncertainty estimates
Annex 3A-8:	Emission inventory 2020 based on SNAP sectors
Annex 3A-9:	EU ETS data

Annex 3A-1 Correspondence list between SNAP and CRF source categories

Table 3A-1.1 Correspondence list between SNAP and CRF source categories for stationary combustion.

snap_name	CRF id	CRF name	
010100	Public power	1A1a	Public electricity and heat production
010101	Combustion plants >= 300 MW (boilers)	1A1a	Public electricity and heat production
010102	Combustion plants >= 50 and < 300 MW (boilers)	1A1a	Public electricity and heat production
010103	Combustion plants < 50 MW (boilers)	1A1a	Public electricity and heat production
010104	Gas turbines	1A1a	Public electricity and heat production
010105	Stationary engines	1A1a	Public electricity and heat production
010200	District heating plants	1A1a	Public electricity and heat production
010201	Combustion plants >= 300 MW (boilers)	1A1a	Public electricity and heat production
010202	Combustion plants >= 50 and < 300 MW (boilers)	1A1a	Public electricity and heat production
010203	Combustion plants < 50 MW (boilers)	1A1a	Public electricity and heat production
010204	Gas turbines	1A1a	Public electricity and heat production
010205	Stationary engines	1A1a	Public electricity and heat production
010300	Petroleum refining plants	1A1b	Petroleum refining
010301	Combustion plants >= 300 MW (boilers)	1A1b	Petroleum refining
010302	Combustion plants >= 50 and < 300 MW (boilers)	1A1b	Petroleum refining
010303	Combustion plants < 50 MW (boilers)	1A1b	Petroleum refining
010304	Gas turbines	1A1b	Petroleum refining
010305	Stationary engines	1A1b	Petroleum refining
010306	Process furnaces	1A1b	Petroleum refining
010400	Solid fuel transformation plants	1A1c	Oil and gas extraction
010401	Combustion plants >= 300 MW (boilers)	1A1c	Oil and gas extraction
010402	Combustion plants >= 50 and < 300 MW (boilers)	1A1c	Oil and gas extraction
010403	Combustion plants < 50 MW (boilers)	1A1c	Oil and gas extraction
010404	Gas turbines	1A1c	Oil and gas extraction
010405	Stationary engines	1A1c	Oil and gas extraction
010406	Coke oven furnaces	1A1c	Oil and gas extraction
010407	Other (coal gasification, liquefaction)	1A1c	Oil and gas extraction
010500	Coal mining, oil / gas extraction, pipeline compressors	1A1c	Oil and gas extraction
010501	Combustion plants >= 300 MW (boilers)	1A1c	Oil and gas extraction
010502	Combustion plants >= 50 and < 300 MW (boilers)	1A1c	Oil and gas extraction
010503	Combustion plants < 50 MW (boilers)	1A1c	Oil and gas extraction
010504	Gas turbines	1A1c	Oil and gas extraction
010505	Stationary engines	1A1c	Oil and gas extraction
010506	Pipeline compressors	1A3e i	Pipeline transport
020100	Commercial and institutional plants	1A4a i	Commercial/institutional: Stationary
020101	Combustion plants >= 300 MW (boilers)	1A4a i	Commercial/institutional: Stationary
020102	Combustion plants >= 50 and < 300 MW (boilers)	1A4a i	Commercial/institutional: Stationary
020103	Combustion plants < 50 MW (boilers)	1A4a i	Commercial/institutional: Stationary
020104	Stationary gas turbines	1A4a i	Commercial/institutional: Stationary
020105	Stationary engines	1A4a i	Commercial/institutional: Stationary
020106	Other stationary equipments	1A4a i	Commercial/institutional: Stationary
020200	Residential plants	1A4b i	Residential: Stationary
020201	Combustion plants >= 50 MW (boilers)	1A4b i	Residential: Stationary
020202	Combustion plants < 50 MW (boilers)	1A4b i	Residential: Stationary
020203	Gas turbines	1A4b i	Residential: Stationary
020204	Stationary engines	1A4b i	Residential: Stationary
020205	Other equipments (stoves, fireplaces, cooking)	1A4b i	Residential: Stationary
020300	Plants in agriculture, forestry and aquaculture	1A4c i	Agriculture/Forestry/Fishing: Stationary
020301	Combustion plants >= 50 MW (boilers)	1A4c i	Agriculture/Forestry/Fishing: Stationary
020302	Combustion plants < 50 MW (boilers)	1A4c i	Agriculture/Forestry/Fishing: Stationary
020303	Stationary gas turbines	1A4c i	Agriculture/Forestry/Fishing: Stationary
020304	Stationary engines	1A4c i	Agriculture/Forestry/Fishing: Stationary
020305	Other stationary equipments	1A4c i	Agriculture/Forestry/Fishing: Stationary
030100	Comb. in boilers, gas turbines and stationary	1A2g viii	Other manufacturing industry
030101	Combustion plants >= 300 MW (boilers)	1A2g viii	Other manufacturing industry
030102	Combustion plants >= 50 and < 300 MW (boilers)	1A2g viii	Other manufacturing industry
030103	Combustion plants < 50 MW (boilers)	1A2g viii	Other manufacturing industry
030104	Gas turbines	1A2g viii	Other manufacturing industry
030105	Stationary engines	1A2g viii	Other manufacturing industry

	snap_name	CRF id	CRF name
030106	Other stationary equipments	1A2g viii	Other manufacturing industry
030200	Process furnaces without contact (a)	1A2g viii	Other manufacturing industry
030203	Blast furnace cowpers	1A2a	Iron and steel
030204	Plaster furnaces	1A2g viii	Other manufacturing industry
030205	Other furnaces	1A2g viii	Other manufacturing industry
030400	Iron and Steel	1A2a	Iron and steel
030401	Combustion plants >= 300 MW (boilers)	1A2a	Iron and steel
030402	Combustion plants >= 50 and < 300 MW (boilers)	1A2a	Iron and steel
030403	Combustion plants < 50 MW (boilers)	1A2a	Iron and steel
030404	Gas turbines	1A2a	Iron and steel
030405	Stationary engines	1A2a	Iron and steel
030406	Other stationary equipments	1A2a	Iron and steel
030500	Non-Ferrous Metals	1A2b	Non-ferrous metals
030501	Combustion plants >= 300 MW (boilers)	1A2b	Non-ferrous metals
030502	Combustion plants >= 50 and < 300 MW (boilers)	1A2b	Non-ferrous metals
030503	Combustion plants < 50 MW (boilers)	1A2b	Non-ferrous metals
030504	Gas turbines	1A2b	Non-ferrous metals
030505	Stationary engines	1A2b	Non-ferrous metals
030506	Other stationary equipments	1A2b	Non-ferrous metals
030600	Chemical and Petrochemical	1A2c	Chemicals
030601	Combustion plants >= 300 MW (boilers)	1A2c	Chemicals
030602	Combustion plants >= 50 and < 300 MW (boilers)	1A2c	Chemicals
030603	Combustion plants < 50 MW (boilers)	1A2c	Chemicals
030604	Gas turbines	1A2c	Chemicals
030605	Stationary engines	1A2c	Chemicals
030606	Other stationary equipments	1A2c	Chemicals
030700	Non-Metallic Minerals	1A2f	Non-metallic minerals
030701	Mineral wool	1A2f	Non-metallic minerals
030702	Glass	1A2f	Non-metallic minerals
030703	Tile	1A2f	Non-metallic minerals
030704	Gas turbines	1A2f	Non-metallic minerals
030705	Stationary engines	1A2f	Non-metallic minerals
030706	Other non-metallic minerals	1A2f	Non-metallic minerals
030800	Mining and Quarrying	1A2g viii	Other manufacturing industry
030801	Combustion plants >= 300 MW (boilers)	1A2g viii	Other manufacturing industry
030802	Combustion plants >= 50 and < 300 MW (boilers)	1A2g viii	Other manufacturing industry
030803	Combustion plants < 50 MW (boilers)	1A2g viii	Other manufacturing industry
030804	Gas turbines	1A2g viii	Other manufacturing industry
030805	Stationary engines	1A2g viii	Other manufacturing industry
030806	Other stationary equipments	1A2g viii	Other manufacturing industry
030900	Food and Tobacco	1A2e	Food processing, beverages and tobacco
030901	Combustion plants >= 300 MW (boilers)	1A2e	Food processing, beverages and tobacco
030902	Combustion plants >= 50 and < 300 MW (boilers)	1A2e	Food processing, beverages and tobacco
030903	Combustion plants < 50 MW (boilers)	1A2e	Food processing, beverages and tobacco
030904	Gas turbines	1A2e	Food processing, beverages and tobacco
030905	Stationary engines	1A2e	Food processing, beverages and tobacco
030906	Other stationary equipments	1A2e	Food processing, beverages and tobacco
031000	Textile and Leather	1A2g viii	Other manufacturing industry
031001	Combustion plants >= 300 MW (boilers)	1A2g viii	Other manufacturing industry
031002	Combustion plants >= 50 and < 300 MW (boilers)	1A2g viii	Other manufacturing industry
031003	Combustion plants < 50 MW (boilers)	1A2g viii	Other manufacturing industry
031004	Gas turbines	1A2g viii	Other manufacturing industry
031005	Stationary engines	1A2g viii	Other manufacturing industry
031006	Other stationary equipments	1A2g viii	Other manufacturing industry
031100	Paper, Pulp and Print	1A2d	Pulp, Paper and Print
031101	Combustion plants >= 300 MW (boilers)	1A2d	Pulp, Paper and Print
031102	Combustion plants >= 50 and < 300 MW (boilers)	1A2d	Pulp, Paper and Print
031103	Combustion plants < 50 MW (boilers)	1A2d	Pulp, Paper and Print
031104	Gas turbines	1A2d	Pulp, Paper and Print
031105	Stationary engines	1A2d	Pulp, Paper and Print
031106	Other stationary equipments	1A2d	Pulp, Paper and Print
031200	Transport Equipment	1A2g viii	Other manufacturing industry
031201	Combustion plants >= 300 MW (boilers)	1A2g viii	Other manufacturing industry

	snap_name	CRF id	CRF name
031202	Combustion plants >= 50 and < 300 MW (boilers)	1A2g viii	Other manufacturing industry
031203	Combustion plants < 50 MW (boilers)	1A2g viii	Other manufacturing industry
031204	Gas turbines	1A2g viii	Other manufacturing industry
031205	Stationary engines	1A2g viii	Other manufacturing industry
031206	Other stationary equipments	1A2g viii	Other manufacturing industry
031300	Machinery	1A2g viii	Other manufacturing industry
031301	Combustion plants >= 300 MW (boilers)	1A2g viii	Other manufacturing industry
031302	Combustion plants >= 50 and < 300 MW (boilers)	1A2g viii	Other manufacturing industry
031303	Combustion plants < 50 MW (boilers)	1A2g viii	Other manufacturing industry
031304	Gas turbines	1A2g viii	Other manufacturing industry
031305	Stationary engines	1A2g viii	Other manufacturing industry
031306	Other stationary equipments	1A2g viii	Other manufacturing industry
031400	Wood and Wood Products	1A2g viii	Other manufacturing industry
031401	Combustion plants >= 300 MW (boilers)	1A2g viii	Other manufacturing industry
031402	Combustion plants >= 50 and < 300 MW (boilers)	1A2g viii	Other manufacturing industry
031403	Combustion plants < 50 MW (boilers)	1A2g viii	Other manufacturing industry
031404	Gas turbines	1A2g viii	Other manufacturing industry
031405	Stationary engines	1A2g viii	Other manufacturing industry
031406	Other stationary equipments	1A2g viii	Other manufacturing industry
031500	Construction	1A2g viii	Other manufacturing industry
031501	Combustion plants >= 300 MW (boilers)	1A2g viii	Other manufacturing industry
031502	Combustion plants >= 50 and < 300 MW (boilers)	1A2g viii	Other manufacturing industry
031503	Combustion plants < 50 MW (boilers)	1A2g viii	Other manufacturing industry
031504	Gas turbines	1A2g viii	Other manufacturing industry
031505	Stationary engines	1A2g viii	Other manufacturing industry
031506	Other stationary equipments	1A2g viii	Other manufacturing industry
031600	Cement production	1A2f	Non-metallic minerals
031601	Combustion plants >= 300 MW (boilers)	1A2f	Non-metallic minerals
031602	Combustion plants >= 50 and < 300 MW (boilers)	1A2f	Non-metallic minerals
031603	Combustion plants < 50 MW (boilers)	1A2f	Non-metallic minerals
031604	Gas turbines	1A2f	Non-metallic minerals
031605	Stationary engines	1A2f	Non-metallic minerals
031606	Other stationary equipments	1A2f	Non-metallic minerals
032000	Non-specified (Industry)	1A2g viii	Other manufacturing industry
032001	Combustion plants >= 300 MW (boilers)	1A2g viii	Other manufacturing industry
032002	Combustion plants >= 50 and < 300 MW (boilers)	1A2g viii	Other manufacturing industry
032003	Combustion plants < 50 MW (boilers)	1A2g viii	Other manufacturing industry
032004	Gas turbines	1A2g viii	Other manufacturing industry
032005	Stationary engines	1A2g viii	Other manufacturing industry
032006	Other stationary equipments	1A2g viii	Other manufacturing industry

Annex 3A-2 Fuel rate

Table 3A-2.1 Fuel consumption rate for stationary combustion plants 1990-2020, PJ.

Sum of Fuel_rate_PJ			Year									
fuel_type	fuel_id	fuel_gr_abbr	1990	1991	1992	1993	1994	1995	1996	1997	1998	1999
SOLID	101A	Other solid fossil										
	102A	Coal	253.4	344.3	286.8	300.8	323.4	270.3	371.9	276.3	234.3	196.5
	103A	Fly ash (fossil)										
	106A	BKB	0.1	0.2	0.1	0.1	0.1	0.1	0.1	0.1	0.0	0.0
	107A	Coke oven coke	1.3	1.4	1.2	1.2	1.2	1.3	1.2	1.3	1.3	1.4
LIQUID	110A	Petroleum coke	4.5	4.4	4.3	5.7	7.5	5.3	5.9	6.0	5.3	6.8
	203A	Residual oil	32.1	37.0	37.3	32.5	46.6	33.3	38.1	26.7	29.5	23.0
	204A	Gas oil	69.7	73.0	63.6	69.3	60.6	60.5	64.2	57.5	54.2	53.2
	206A	Kerosene	5.1	1.0	0.8	0.8	0.7	0.6	0.5	0.4	0.4	0.3
	225A	Orimulsion						19.9	36.8	40.5	32.6	34.2
	303A	LPG	3.0	2.8	2.5	2.6	2.6	2.8	3.1	2.6	2.8	2.5
	308A	Refinery gas	14.2	14.5	14.9	15.4	16.4	20.8	21.4	16.9	15.2	15.7
GAS	301A	Natural gas	76.1	86.1	90.5	102.5	114.6	132.7	156.3	164.5	178.7	187.9
WASTE	114A	Waste	15.5	16.7	17.8	19.4	20.3	22.9	25.0	26.8	26.6	29.1
	115A	Industrial waste										
BIOMASS	111A	Wood	16.7	17.9	18.6	20.1	19.7	19.5	20.7	20.5	19.7	20.3
	117A	Straw	12.5	13.3	13.9	13.4	12.7	13.1	13.5	13.9	13.9	13.7
		Wood pellets	1.6	2.1	2.5	2.1	2.1	2.3	2.7	2.9	3.2	4.0
	215A	Bio oil	0.7	0.7	0.7	0.8	0.2	0.3	0.1	0.0	0.0	0.0
	309A	Biogas	0.8	0.9	0.9	1.1	1.3	1.8	2.0	2.4	2.7	2.7
	310A	Bio gasification gas					0.1	0.0	0.0	0.0	0.0	0.0
	315A	Bio natural gas										
Total			507.2	616.6	556.3	587.7	630.1	607.5	763.4	659.2	620.5	591.4
Sum of Fuel_rate_PJ			Year									
fuel_type	fuel_id	fuel_gr_abbr	2000	2001	2002	2003	2004	2005	2006	2007	2008	2009
SOLID	101A	Other solid fossil										0.0
	102A	Coal	164.7	174.3	174.7	239.0	182.5	154.0	232.0	194.1	170.5	167.7
	103A	Fly ash (fossil)										
	106A	BKB	0.0	0.0	0.0	0.0					0.0	0.0
	107A	Coke oven coke	1.2	1.1	1.1	1.0	1.1	1.0	1.0	1.1	1.0	0.8
LIQUID	110A	Petroleum coke	6.8	7.8	7.8	8.0	8.4	8.1	8.5	9.2	6.9	5.9
	203A	Residual oil	18.0	20.2	24.8	27.3	23.5	21.1	25.4	19.3	15.3	14.2
	204A	Gas oil	46.4	48.6	43.4	43.2	40.3	36.4	31.7	27.3	26.9	28.8
	206A	Kerosene	0.2	0.3	0.3	0.3	0.2	0.3	0.2	0.1	0.1	0.1
	225A	Orimulsion	34.1	30.2	23.8	1.9	0.0					
	303A	LPG	2.4	2.1	2.0	2.1	2.1	2.1	2.2	1.9	1.7	1.5
	308A	Refinery gas	15.6	15.8	15.2	16.6	15.9	15.3	16.1	15.9	14.1	15.0
GAS	301A	Natural gas	186.1	193.8	193.6	195.9	195.1	187.4	191.1	171.0	173.0	165.7
WASTE	114A	Waste	29.8	31.3	33.3	35.1	35.3	35.8	37.8	38.9	40.1	38.1
	115A	Industrial waste	0.5	1.4	1.9	1.5	2.0	2.0	0.6	0.9	1.4	1.2
BIOMASS	111A	Wood	22.3	23.7	23.7	29.1	31.1	33.7	36.5	43.8	45.1	45.9
	117A	Straw	12.2	13.7	15.7	16.9	17.9	18.5	18.5	18.8	15.9	17.4
		Wood pellets	5.1	7.1	7.9	9.8	12.8	16.1	15.6	16.5	18.5	20.1
	215A	Bio oil	0.0	0.2	0.1	0.4	0.6	0.8	1.1	1.2	1.8	1.7
	309A	Biogas	2.9	3.0	3.4	3.6	3.7	3.8	3.9	3.9	3.9	4.2
	310A	Bio gasification gas	0.0	0.1	0.1	0.1	0.1	0.1	0.1	0.1	0.1	0.3
	315A	Bio natural gas										
Total			548.7	574.8	572.5	631.8	572.6	536.4	622.4	563.9	536.4	528.6

			Year										
Sum of Fuel_rate_PJ													
fuel_type	fuel_id	fuel_gr_abbr	2010	2011	2012	2013	2014	2015	2016	2017	2018	2019	
SOLID	101A	Other solid fossil	0.0	0.0	0.0	0.0							
	102A	Coal	163.0	135.5	106.2	135.0	107.0	76.0	88.2	65.8	67.2	37.8	
	103A	Fly ash (fossil)		0.0	0.1	0.1	0.0	0.0	0.1	0.1	0.0	0.0	
	106A	BKB	0.0	0.0	0.0	0.0	0.0		0.0				
	107A	Coke oven coke	0.7	0.7	0.6	0.6	0.6	0.5	0.3	0.3	0.4	0.3	
	LIQUID	110A	Petroleum coke	5.1	6.5	6.7	6.1	6.6	6.6	7.6	7.9	6.9	7.7
		203A	Residual oil	12.8	7.8	7.2	5.5	4.5	4.2	4.1	4.1	3.2	3.0
204A		Gas oil	28.5	22.4	18.7	17.1	10.3	11.3	11.6	9.9	11.4	8.4	
206A		Kerosene	0.1	0.0	0.0	0.0	0.0	0.0	0.0	0.0	0.2	0.2	
225A		Orimulsion											
303A		LPG	1.6	1.5	1.7	1.6	1.3	1.8	2.1	2.3	2.3	2.3	
308A		Refinery gas	14.3	13.7	14.8	14.8	15.4	16.2	14.4	15.6	15.0	16.1	
GAS	301A	Natural gas	186.0	157.5	147.3	139.5	119.4	120.7	122.6	116.6	113.2	105.6	
WASTE	114A	Waste	37.2	37.1	36.1	35.9	37.1	37.7	37.8	38.1	37.1	38.4	
	115A	Industrial waste	0.9	1.3	1.2	1.6	1.6	2.2	2.6	2.7	3.4	3.1	
BIOMASS	111A	Wood	51.3	48.8	48.6	46.4	45.0	50.1	51.6	51.6	52.7	52.4	
	117A	Straw	23.3	20.2	18.3	20.3	18.6	19.8	19.7	20.2	17.6	18.0	
	122A	Wood pellets	29.9	30.0	33.2	34.6	36.3	36.5	44.3	57.4	55.2	53.3	
	215A	Bio oil	2.0	0.8	1.1	0.9	0.7	0.6	0.3	0.2	0.2	0.1	
	309A	Biogas	4.3	4.1	4.4	4.6	5.2	5.3	5.9	5.8	6.3	6.9	
	310A	Bio gasification gas	0.2	0.3	0.4	0.4	0.4	0.5	0.5	1.0	1.4	1.5	
	315A	Bio natural gas					0.3	1.0	3.1	5.2	7.1	9.4	
Total			561.2	488.3	446.7	464.9	410.5	391.1	416.7	404.8	400.7	364.7	
			Year										
Sum of Fuel_rate_PJ													
fuel_type	fuel_id	fuel_gr_abbr	2020										
SOLID	101A	Other solid fossil											
	102A	Coal	32.9										
	103A	Fly ash (fossil)	0.0										
	106A	BKB											
	107A	Coke oven coke	0.3										
	LIQUID	110A	Petroleum coke	7.9									
		203A	Residual oil	3.1									
204A		Gas oil	7.6										
206A		Kerosene	0.0										
225A		Orimulsion											
303A		LPG	2.3										
308A		Refinery gas	15.3										
GAS	301A	Natural gas	85.4										
WASTE	114A	Waste	38.2										
	115A	Industrial waste	3.4										
BIOMASS	111A	Wood	57.7										
	117A	Straw	18.9										
	122A	Wood pellets	47.1										
	215A	Bio oil	0.1										
	309A	Biogas	7.0										
	310A	Bio gasification gas	1.6										
	315A	Bio natural gas	13.5										
Total			342.3										

Table 3A-2.2 Detailed fuel consumption data for stationary combustion plants, 1990-2020, PJ.

This table is available at: <https://envs.au.dk/en/faglige-omraader/luftforurening-udledninger-og-effekter/udledning-af-luftforurening/greenhouse-gases/supporting-documentation>

Annex 3A-3 Default Lower Calorific Value (LCV) of fuels and fuel correspondence list

Table 3A-3.1 Time series for calorific values of fuels (DEA, 2021a).

		1990	1991	1992	1993	1994	1995	1996	1997	1998	1999
Crude Oil, Average	GJ per tonne	42.40	42.40	42.40	42.70	42.70	42.70	42.70	43.00	43.00	43.00
Crude Oil, Golf	GJ per tonne	41.80	41.80	41.80	41.80	41.80	41.80	41.80	41.80	41.80	41.80
Crude Oil, North Sea	GJ per tonne	42.70	42.70	42.70	42.70	42.70	42.70	42.70	43.00	43.00	43.00
Refinery Feedstocks	GJ per tonne	41.60	41.60	41.60	41.60	41.60	41.60	41.60	42.70	42.70	42.70
Refinery Gas	GJ per tonne	52.00	52.00	52.00	52.00	52.00	52.00	52.00	52.00	52.00	52.00
LPG	GJ per tonne	46.00	46.00	46.00	46.00	46.00	46.00	46.00	46.00	46.00	46.00
Naphtha (LVN)	GJ per tonne	44.50	44.50	44.50	44.50	44.50	44.50	44.50	44.50	44.50	44.50
Motor Gasoline	GJ per tonne	43.80	43.80	43.80	43.80	43.80	43.80	43.80	43.80	43.80	43.80
Aviation Gasoline	GJ per tonne	43.80	43.80	43.80	43.80	43.80	43.80	43.80	43.80	43.80	43.80
JP4	GJ per tonne	43.80	43.80	43.80	43.80	43.80	43.80	43.80	43.80	43.80	43.80
Other Kerosene	GJ per tonne	43.50	43.50	43.50	43.50	43.50	43.50	43.50	43.50	43.50	43.50
JP1	GJ per tonne	43.50	43.50	43.50	43.50	43.50	43.50	43.50	43.50	43.50	43.50
Gas/Diesel Oil	GJ per tonne	42.70	42.70	42.70	42.70	42.70	42.70	42.70	42.70	42.70	42.70
Fuel Oil	GJ per tonne	40.40	40.40	40.40	40.40	40.40	40.40	40.70	40.65	40.65	40.65
Orimulsion	GJ per tonne	27.60	27.60	27.60	27.60	27.60	28.13	28.02	27.72	27.84	27.58
Petroleum Coke	GJ per tonne	31.40	31.40	31.40	31.40	31.40	31.40	31.40	31.40	31.40	31.40
Waste Oil	GJ per tonne	41.90	41.90	41.90	41.90	41.90	41.90	41.90	41.90	41.90	41.90
White Spirit	GJ per tonne	43.50	43.50	43.50	43.50	43.50	43.50	43.50	43.50	43.50	43.50
Bitumen	GJ per tonne	39.80	39.80	39.80	39.80	39.80	39.80	39.80	39.80	39.80	39.80
Lubricants	GJ per tonne	41.90	41.90	41.90	41.90	41.90	41.90	41.90	41.90	41.90	41.90
Natural Gas	GJ per 1000 Nm ³	39.00	39.00	39.00	39.30	39.30	39.30	39.30	39.60	39.90	40.00
Town Gas	GJ per 1000 m ³							17.00	17.00	17.00	17.00
Liquefied Natural Gas	GJ per 1000 m ³										
Electricity Plant Coal	GJ per tonne	25.30	25.40	25.80	25.20	24.50	24.50	24.70	24.96	25.00	25.00
Other Hard Coal	GJ per tonne	26.10	26.50	26.50	26.50	26.50	26.50	26.50	26.50	26.50	26.50
Coke	GJ per tonne	31.80	29.30	29.30	29.30	29.30	29.30	29.30	29.30	29.30	29.30
Brown Coal Briquettes	GJ per tonne	18.30	18.30	18.30	18.30	18.30	18.30	18.30	18.30	18.30	18.30
Straw	GJ per tonne	14.50	14.50	14.50	14.50	14.50	14.50	14.50	14.50	14.50	14.50
Wood Chips	GJ per m ³	2.80	2.80	2.80	2.80	2.80	2.80	2.80	2.80	2.80	2.80
Wood Chips	GJ per tonne	9.30	9.30	9.30	9.30	9.30	9.30	9.30	9.30	9.30	9.30
Firewood, Hardwood	GJ per m ³	10.40	10.40	10.40	10.40	10.40	10.40	10.40	10.40	10.40	10.40
Firewood, Conifer	GJ per tonne	7.60	7.60	7.60	7.60	7.60	7.60	7.60	7.60	7.60	7.60
Wood Pellets	GJ per tonne	17.50	17.50	17.50	17.50	17.50	17.50	17.50	17.50	17.50	17.50
Wood Waste	GJ per tonne	14.70	14.70	14.70	14.70	14.70	14.70	14.70	14.70	14.70	14.70
Wood Waste	GJ per m ³	3.20	3.20	3.20	3.20	3.20	3.20	3.20	3.20	3.20	3.20
Biogas	GJ per 1000 m ³								23.00	23.00	23.00
Wastes	GJ per tonne	8.20	8.20	9.00	9.40	9.40	10.00	10.50	10.50	10.50	10.50
Bioethanol	GJ per tonne	26.70	26.70	26.70	26.70	26.70	26.70	26.70	26.70	26.70	26.70
Liquid Biofuels	GJ per tonne	37.60	37.60	37.60	37.60	37.60	37.60	37.60	37.60	37.60	37.60
Bio Oil	GJ per tonne	37.20	37.20	37.20	37.20	37.20	37.20	37.20	37.20	37.20	37.20

<i>Continued</i>		2000	2001	2002	2003	2004	2005	2006	2007	2008	2009
Crude Oil, Average	GJ per tonne	43.00	43.00	43.00	43.00	43.00	43.00	43.00	43.00	43.00	43.00
Crude Oil, Gulf	GJ per tonne	41.80	41.80	41.80	41.80	41.80	41.80	41.80	41.80	41.80	41.80
Crude Oil, North Sea	GJ per tonne	43.00	43.00	43.00	43.00	43.00	43.00	43.00	43.00	43.00	43.00
Refinery Feedstocks	GJ per tonne	42.70	42.70	42.70	42.70	42.70	42.70	42.70	42.70	42.70	42.70
Refinery Gas	GJ per tonne	52.00	52.00	52.00	52.00	52.00	52.00	52.00	52.00	52.00	52.00
LPG	GJ per tonne	46.00	46.00	46.00	46.00	46.00	46.00	46.00	46.00	46.00	46.00
Naphtha (LVN)	GJ per tonne	44.50	44.50	44.50	44.50	44.50	44.50	44.50	44.50	44.50	44.50
Motor Gasoline	GJ per tonne	43.80	43.80	43.80	43.80	43.80	43.80	43.80	43.80	43.80	43.80
Aviation Gasoline	GJ per tonne	43.80	43.80	43.80	43.80	43.80	43.80	43.80	43.80	43.80	43.80
JP4	GJ per tonne	43.80	43.80	43.80	43.80	43.80	43.80	43.80	43.80	43.80	43.80
Other Kerosene	GJ per tonne	43.50	43.50	43.50	43.50	43.50	43.50	43.50	43.50	43.50	43.50
JP1	GJ per tonne	43.50	43.50	43.50	43.50	43.50	43.50	43.50	43.50	43.50	43.50
Gas/Diesel Oil	GJ per tonne	42.70	42.70	42.70	42.70	42.70	42.70	42.70	42.70	42.70	42.70
Fuel Oil	GJ per tonne	40.65	40.65	40.65	40.65	40.65	40.65	40.65	40.65	40.65	40.65
Orimulsion	GJ per tonne	27.62	27.64	27.71	27.65	27.65	27.65	27.65	27.65	27.65	27.65
Petroleum Coke	GJ per tonne	31.40	31.40	31.40	31.40	31.40	31.40	31.40	31.40	31.40	31.40
Waste Oil	GJ per tonne	41.90	41.90	41.90	41.90	41.90	41.90	41.90	41.90	41.90	41.90
White Spirit	GJ per tonne	43.50	43.50	43.50	43.50	43.50	43.50	43.50	43.50	43.50	43.50
Bitumen	GJ per tonne	39.80	39.80	39.80	39.80	39.80	39.80	39.80	39.80	39.80	39.80
Lubricants	GJ per tonne	41.90	41.90	41.90	41.90	41.90	41.90	41.90	41.90	41.90	41.90
Natural Gas	GJ per 1000 Nm ³	40.15	39.99	40.06	39.94	39.77	39.67	39.54	39.59	39.48	39.46
Town Gas	GJ per 1000 m ³	17.01	16.88	17.39	16.88	17.58	17.51	17.20	17.14	15.50	21.29
Liquefied Natural Gas	GJ per 1000 m ³										
Electricity Plant Coal	GJ per tonne	24.80	24.90	25.15	24.73	24.60	24.40	24.80	24.40	24.30	24.60
Other Hard Coal	GJ per tonne	26.50	26.50	26.50	26.50	26.50	26.50	26.50	26.50	25.81	25.13
Coke	GJ per tonne	29.30	29.30	29.30	29.30	29.30	29.30	29.30	29.30	29.30	29.30
Brown Coal Briquettes	GJ per tonne	18.30	18.30	18.30	18.30	18.30	18.30	18.30	18.30	18.30	18.30
Straw	GJ per tonne	14.50	14.50	14.50	14.50	14.50	14.50	14.50	14.50	14.50	14.50
Wood Chips	GJ per m ³	2.80	2.80	2.80	2.80	2.80	2.80	2.80	2.80	2.80	2.80
Wood Chips	GJ per tonne	9.30	9.30	9.30	9.30	9.30	9.30	9.30	9.30	9.30	9.30
Firewood, Hardwood	GJ per m ³	10.40	10.40	10.40	10.40	10.40	10.40	10.40	10.40	10.40	10.40
Firewood, Conifer	GJ per tonne	7.60	7.60	7.60	7.60	7.60	7.60	7.60	7.60	7.60	7.60
Wood Pellets	GJ per tonne	17.50	17.50	17.50	17.50	17.50	17.50	17.50	17.50	17.50	17.50
Wood Waste	GJ per tonne	14.70	14.70	14.70	14.70	14.70	14.70	14.70	14.70	14.70	14.70
Wood Waste	GJ per m ³	3.20	3.20	3.20	3.20	3.20	3.20	3.20	3.20	3.20	3.20
Biogas	GJ per 1000 m ³	23.00	23.00	23.00	23.00	23.00	23.00	23.00	23.00	23.00	23.00
Wastes	GJ per tonne	10.50	10.50	10.50	10.50	10.50	10.50	10.50	10.50	10.50	10.50
Bioethanol	GJ per tonne	26.70	26.70	26.70	26.70	26.70	26.70	26.70	26.70	26.70	26.70
Liquid Biofuels	GJ per tonne	37.60	37.60	37.60	37.60	37.60	37.60	37.60	37.60	37.50	37.50
Bio Oil	GJ per tonne	37.20	37.20	37.20	37.20	37.20	37.20	37.20	37.20	37.20	37.20

<i>Continued</i>		2010	2011	2012	2013	2014	2015	2016	2017	2018	2019
Crude Oil, Average	GJ per tonne	43.00	43.00	43.00	43.00	43.00	43.00	43.00	43.00	43.00	43.00
Crude Oil, Gulf	GJ per tonne	41.80	41.80	41.80	41.80	41.80	41.80	41.80	41.80	41.80	41.80
Crude Oil, North Sea	GJ per tonne	43.00	43.00	43.00	43.00	43.00	43.00	43.00	43.00	43.00	43.00
Refinery Feedstocks	GJ per tonne	42.70	42.70	42.70	42.70	42.70	42.70	42.70	42.70	42.70	42.70
Refinery Gas	GJ per tonne	52.00	52.00	52.00	52.00	52.00	52.00	52.00	52.00	52.00	52.00
LPG	GJ per tonne	46.00	46.00	46.00	46.00	46.00	46.00	46.00	46.00	46.00	46.00
Naphtha (LVN)	GJ per tonne	44.50	44.50	44.50	44.50	44.50	44.50	44.50	44.50	44.50	44.50
Motor Gasoline	GJ per tonne	43.80	43.80	43.80	43.80	43.80	43.80	43.80	43.80	43.80	43.80
Aviation Gasoline	GJ per tonne	43.80	43.80	43.80	43.80	43.80	43.80	43.80	43.80	43.80	43.80
JP4	GJ per tonne	43.80	43.80	43.80	43.80	43.80	43.80	43.80	43.80	43.80	43.80
Other Kerosene	GJ per tonne	43.50	43.50	43.50	43.50	43.50	43.50	43.50	43.50	43.50	43.50
JP1	GJ per tonne	43.50	43.50	43.50	43.50	43.50	43.50	43.50	43.50	43.50	43.50
Gas/Diesel Oil	GJ per tonne	42.70	42.70	42.70	42.70	42.70	42.70	42.70	42.70	42.70	42.70
Fuel Oil	GJ per tonne	40.65	40.65	40.65	40.65	40.65	40.65	40.65	40.65	40.65	40.65
Orimulsion	GJ per tonne	27.65	27.65	27.65	27.65	27.65	27.65	27.65	27.65	27.65	27.65
Petroleum Coke	GJ per tonne	31.40	31.40	31.40	31.40	31.40	31.40	31.40	31.40	31.40	31.40
Waste Oil	GJ per tonne	41.90	41.90	41.90	41.90	41.90	41.90	41.90	41.90	41.90	41.90
White Spirit	GJ per tonne	43.50	43.50	43.50	43.50	43.50	43.50	43.50	43.50	43.50	43.50
Bitumen	GJ per tonne	39.80	39.80	39.80	39.80	39.80	39.80	39.80	39.80	39.80	39.80
Lubricants	GJ per tonne	41.90	41.90	41.90	41.90	41.90	41.90	41.90	41.90	41.90	41.90
Natural Gas	GJ per 1000 Nm ³	39.46	39.51	39.55	38.99	39.53	39.64	39.63	39.66	39.59	38.81
Town Gas	GJ per 1000 m ³	21.35	21.37	19.30	19.31	20.20	19.80	20.28	20.80	20.82	20.80
Liquefied Natural Gas	GJ per 1000 m ³						26.50	26.50	26.50	26.50	26.50
Electricity Plant Coal	GJ per tonne	24.44	24.38	24.23	24.49	24.70	24.10	24.29	24.33	24.13	23.89
Other Hard Coal	GJ per tonne	24.44	24.38	24.23	24.49	24.70	24.10	26.10	26.88	26.64	24.17
Coke	GJ per tonne	29.30	29.30	29.30	29.30	29.30	29.30	29.30	29.30	29.30	29.30
Brown Coal Briquettes	GJ per tonne	18.30	18.30	18.30	18.30	18.30	18.30	18.30	18.30	18.30	18.30
Straw	GJ per tonne	14.50	14.50	14.50	14.50	14.50	14.50	14.50	14.50	14.50	14.50
Wood Chips	GJ per m ³	2.80	2.80	2.80	2.80	2.80	2.80	2.80	2.80	2.80	2.80
Wood Chips	GJ per tonne	9.30	9.30	9.30	9.30	9.30	9.30	9.30	9.30	9.30	9.30
Firewood, Hardwood	GJ per m ³	10.40	10.40	10.40	10.40	10.40	10.40	10.40	10.40	10.40	10.40
Firewood, Conifer	GJ per tonne	7.60	7.60	7.60	7.60	7.60	7.60	7.60	7.60	7.60	7.60
Wood Pellets	GJ per tonne	17.50	17.50	17.50	17.50	17.50	17.50	17.50	17.50	17.50	17.50
Wood Waste	GJ per tonne	14.70	14.70	14.70	14.70	14.70	14.70	14.70	14.70	14.70	14.70
Wood Waste	GJ per m ³	3.20	3.20	3.20	3.20	3.20	3.20	3.20	3.20	3.20	3.20
Biogas	GJ per 1000 m ³	23.00	23.00	23.00	23.00	23.00	23.00	23.00	23.00	23.00	23.00
Wastes	GJ per tonne	10.50	10.50	10.50	10.60	10.60	10.60	10.60	10.60	10.60	10.60
Bioethanol	GJ per tonne	26.70	26.70	26.70	26.70	26.70	26.70	26.70	26.70	26.70	26.70
Liquid Biofuels	GJ per tonne	37.50	37.50	37.50	37.50	37.50	37.50	37.50	37.50	37.50	37.50
Bio Oil	GJ per tonne	37.20	37.20	37.20	37.20	37.20	37.20	37.20	37.20	37.20	37.20

<i>Continued</i>		2020
Crude Oil, Average	GJ per tonne	43.00
Crude Oil, Golf	GJ per tonne	41.80
Crude Oil, North Sea	GJ per tonne	43.00
Refinery Feedstocks	GJ per tonne	42.70
Refinery Gas	GJ per tonne	52.00
LPG	GJ per tonne	46.00
Naphtha (LVN)	GJ per tonne	44.50
Motor Gasoline	GJ per tonne	43.80
Aviation Gasoline	GJ per tonne	43.80
JP4	GJ per tonne	43.80
Other Kerosene	GJ per tonne	43.50
JP1	GJ per tonne	43.50
Gas/Diesel Oil	GJ per tonne	42.70
Fuel Oil	GJ per tonne	40.65
Orimulsion	GJ per tonne	27.65
Petroleum Coke	GJ per tonne	31.40
Waste Oil	GJ per tonne	41.90
White Spirit	GJ per tonne	43.50
Bitumen	GJ per tonne	39.80
Lubricants	GJ per tonne	41.90
Natural Gas	GJ per 1000 Nm ³	36.70
Town Gas	GJ per 1000 m ³	20.78
Liquefied Natural Gas	GJ per 1000 m ³	26.50
Electricity Plant Coal	GJ per tonne	23.89
Other Hard Coal	GJ per tonne	24.17
Coke	GJ per tonne	29.30
Brown Coal Briquettes	GJ per tonne	18.30
Straw	GJ per tonne	14.50
Wood Chips	GJ per m ³	2.80
Wood Chips	GJ per tonne	9.30
Firewood, Hardwood	GJ per m ³	10.40
Firewood, Conifer	GJ per tonne	7.60
Wood Pellets	GJ per tonne	17.50
Wood Waste	GJ per tonne	14.70
Wood Waste	GJ per m ³	3.20
Biogas	GJ per 1000 m ³	23.00
Wastes	GJ per tonne	10.60
Bioethanol	GJ per tonne	26.70
Liquid Biofuels	GJ per tonne	37.50
Bio Oil	GJ per tonne	37.20

Table 3A-3.2 Fuel category correspondence list, DEA, DCE and Climate Convention reporting (CRF).

Danish Energy Agency	DCE Emission database	IPCC fuel category
Other Hard Coal	Coal	Solid
Coke	Coke oven coke	Solid
Electricity Plant Coal	Coal	Solid
Brown Coal Briquettes	BKB	Solid
-	Other solid fossil	Solid
-	Fly ash fossil	Solid
Orimulsion	Orimulsion	Liquid
Petroleum Coke	Petroleum coke	Liquid
Fuel Oil	Residual oil	Liquid
Waste Oil	Residual oil	Liquid
Gas/Diesel Oil	Gas oil	Liquid
Other Kerosene	Kerosene	Liquid
LPG	LPG	Liquid
Refinery Gas	Refinery gas	Liquid
Town Gas	Natural gas	Gas
Natural Gas	Natural gas	Gas
Straw	Straw	Biomass
Wood Waste	Wood	Biomass
Wood Pellets	Wood pellets	Biomass
Wood Chips	Wood	Biomass
Firewood	Wood	Biomass
Wastes, Renewable	Municipal wastes	Biomass
Biooil	Liquid biofuels	Biomass
Biogas	Biogas	Biomass
(Wood applied in gas engines)	Biomass gasification gas	Biomass
Bio methane	Bio natural gas	Biomass
Biogas distributed in the town gas grid	Biogas	Biomass
Wastes, Non-renewable	Fossil waste	Other fuel

Annex 3A-4 Emission factors

Table 3A-4.1 CO₂ emission factors, 2020.

Fuel	Emission factor, kg per GJ		Reference type	IPCC fuel category
	Biomass	Fossil fuel		
Coal		94.20 ¹⁾	Country specific	Solid
Brown coal briquettes		97.5	IPCC (2006)	Solid
Coke oven coke		107 ³⁾	IPCC (2006)	Solid
Other solid fossil fuels ⁶⁾		118 ¹⁾	Country specific	Solid
Fly ash fossil (from coal)		94.20	Country specific	Solid
Petroleum coke		93 ³⁾	Country-specific	Liquid
Residual oil		79.03 ¹⁾	Country-specific	Liquid
Gas oil		74.1 ¹⁾	Country-specific	Liquid
Kerosene		71.9	IPCC (2006)	Liquid
Orimulsion		80 ²⁾	Country-specific	Liquid
LPG		64.8	Country-specific	Liquid
Refinery gas		56.813	Country-specific	Liquid
Natural gas, offshore gas turbines		57.456	Country-specific	Gas
Natural gas, other		55.52	Country-specific	Gas
Waste	63.3 ³⁾⁴⁾	+ 42.5 ¹⁾³⁾⁴⁾	Country-specific	Biomass and Other fuels
Straw	100		IPCC (2006)	Biomass
Wood	112		IPCC (2006)	Biomass
Wood pellets	112		IPCC (2006)	Biomass
Bio oil	70.8		IPCC (2006)	Biomass
Biogas	84.1		Country-specific	Biomass
Biomass gasification gas	142.9 ⁵⁾		Country-specific	Biomass
Bio natural gas	55.55		Country-specific	Biomass

1) Plant specific data from EU ETS incorporated for individual plants.

2) Not applied in 2020. Orimulsion was applied in Denmark in 1995 – 2004.

3) Plant specific data from EU ETS incorporated for cement industry and sugar, lime and mineral wool production.

4) The emission factor for waste is (42.5+63.3) kg CO₂ per GJ waste. The fuel consumption and the CO₂ emission have been disaggregated to the two IPCC fuel categories Biomass and Other fossil fuels in CRF. The corresponding fossil CO₂ emission factor for Other fuels is 94.44 kg CO₂ per GJ fossil waste and 115 kg biomass CO₂ per GJ biomass waste.

5) Includes a high content of CO₂ in the gas.

6) Anodic carbon. Not applied in Denmark in 2020.

Time series have been estimated for:

- Coal
- Residual oil
- Refinery gas
- Natural gas applied in offshore gas turbines
- Natural gas, other
- Waste, fossil part
- Industrial waste, biomass part

For all other fuels the same emission factor has been applied for 1990-2020.

Table 3A-4.2 CO₂ emission factors, time series.

Year	Coal, kg per GJ	Residual oil, kg per GJ	Refinery gas, kg per GJ	Natural gas, offshore gas turbines, kg per GJ	Natural gas, other, kg per GJ	Waste, fossil part kg fossil CO ₂ per GJ waste	Industrial waste, biomass part, kg biogenic CO ₂ per GJ waste
1990	94	78.7	57.6	57.469	56.9	37	86.7
1991	94	78.7	57.6	57.469	56.9	37	86.7
1992	94	78.7	57.6	57.469	56.9	37	84.2
1993	94	78.7	57.6	57.469	56.9	37	83.0
1994	94	78.7	57.6	57.469	56.9	37	83.0
1995	94	78.7	57.6	57.469	56.9	37	81.1
1996	94	78.7	57.6	57.469	56.9	37	79.6
1997	94	78.7	57.6	57.469	56.9	37	79.6
1998	94	78.7	57.6	57.469	56.9	37	79.6
1999	94	78.7	57.6	57.469	56.9	37	79.6
2000	94	78.7	57.6	57.469	57.1	37	79.6
2001	94	78.7	57.6	57.469	57.25	37	79.6
2002	94	78.7	57.6	57.469	57.28	37	79.6
2003	94	78.7	57.6	57.469	57.19	37	79.6
2004	94	78.7	57.6	57.469	57.12	37	79.6
2005	94	78.7	57.6	57.469	56.96	37	79.6
2006	94.4	78.6	57.812	57.879	56.78	37	79.6
2007	94.3	78.5	57.848	57.784	56.78	37	79.6
2008	94.0	78.5	57.948	56.959	56.77	37	79.6
2009	93.6	78.9	56.817	57.254	56.69	37	79.6
2010	93.6	79.2	57.134	57.314	56.74	37	79.6
2011	94.73	79.25	57.861	57.379	56.97	37.5	79.6
2012	94.25	79.21	58.108	57.423	57.03	40.0	79.6
2013	93.95	79.28	58.274	57.295	56.79	42.5	79.6
2014	94.17	79.49	57.620	57.381	56.95	42.5	79.6
2015	94.46	79.17	57.508	57.615	57.06	42.5	79.6
2016	94.95	79.29	57.335	57.704	57.01	42.5	79.6
2017	94.37	79.19	57.109	57.628	57.00	42.5	79.6
2018	94.04	79.42	56.144	57.639	56.89	42.5	79.6
2019	94.13	79.32	56.452	57.588	56.54	42.5	79.6
2020	94.20	79.03	56.813	57.456	55.52	42.5	79.6

Table 3A-4.3 CH₄ emission factors and references, 20120.

Fuel group	Fuel	CRF source category	CRF source category	SNAP	Emission factor, g per GJ	Reference	
SOLID	Coal	1A1a	Public electricity and heat production	0101 0102	0.9	IPCC (2006), Tier 3, Table 2-6, Utility Boiler, Pulverised bituminous coal combustion, Wet bottom.	
		1A2 a-g	Industry	03	10	IPCC (2006), Tier 1, Table 2-3, Manufacturing industries.	
		1A4b i	Residential	0202	300	IPCC (2006), Tier 1, Table 2.5, Residential, Bituminous coal.	
		1A4c i	Agriculture/Forestry	0203	10	IPCC (2006), Tier 1, Table 2-4, Commercial, coal. ¹⁾	
	BKB	1A4b i	Residential	0202	300	IPCC (2006), Tier 1, Table 2-5, Residential, brown coal briquettes	
	Coke oven coke	1A2 a-g	Industry	03	10	IPCC (2006), Tier 1, Table 2-4, Commercial, coke oven coke.	
		1A4b i	Residential	0202	300	IPCC (2006), Tier 1, Table 2-5, Residential, coke oven coke.	
	Anodic carbon	1A2 a-g	Industry	03	10	IPCC (2006), Tier 1, Table 2-3, Manufacturing industries.	
	Fossil fly ash	1A1a	Public electricity and heat production	0101	0.9	IPCC (2006), Tier 3, Table 2-6, Utility Boiler, Pulverised bituminous coal combustion, Wet bottom.	
	LIQUID	Petroleum coke	1A2 a-g	Industry	03	3	IPCC (2006), Tier 1, Table 2-3, Industry, petroleum coke.
1A4a			Commercial/Institutional	0201	10	IPCC (2006), Tier 1, Table 2-4, Commercial, Petroleum coke.	
1A4b			Residential	0202	10	IPCC (2006), Tier 1, Table 2-5, Residential / agricultural, Petroleum coke.	
1A4c			Agriculture/Forestry	0203	10	IPCC (2006), Tier 1, Table 2-5, Residential / agricultural, Petroleum coke.	
Residual oil		1A1a	Public electricity and heat production	010101	0.8	IPCC (2006), Tier 3, Table 2-6, Utility Boiler, Residual fuel oil.	
				010102 010103	1.3	Nielsen et al. (2010a)	
				010104	3	IPCC (2006), Tier 1, Table 2-2, Energy industries, residual oil.	
				010105	4	IPCC (2006), Tier 3, Table 2-6, Utility, Large diesel engines	
				010203	0.8	IPCC (2006), Tier 3, Table 2-6, Utility Boiler, Residual fuel oil.	
				1A1b	Petroleum refining	010306	3
		1A2 a-g	Industry	03	1.3	Nielsen et al. (2010a)	
				Engines	4	IPCC (2006), Tier 3, Table 2-6, Utility, Large diesel engines	
		1A4a	Commercial/Institutional	0201	1.4	IPCC (2006), Tier 3, Table 2-10, Commercial, residual fuel oil boilers.	
		1A4b	Residential	0202	1.4	IPCC (2006), Tier 3, Table 2-9, Residential, residual fuel oil.	
		1A4c	Agriculture/Forestry	0203	1.4	IPCC (2006), Tier 3, Table 2-10, Commercial, residual fuel oil boilers. ¹⁾	
		Gas oil	1A1a	Public electricity and heat production	010101 010102 010103	0.9	IPCC (2006), Tier 3, Table 2-6, Utility, gas oil, boilers.
010104					3	IPCC (2006), Tier 1, Table 2-2, Energy industries, gas oil.	
010105					24	Nielsen et al. (2010a)	
010202 010203					0.9	IPCC (2006), Tier 3, Table 2-6, Utility, gas oil, boilers.	
1A1b					Petroleum refining	010306	3
1A1c	Oil and gas extraction				010500	0.9	IPCC (2006), Tier 3, Table 2-6, Utility, gas oil, boilers.
1A2 a-g	Industry		03	0.2	IPCC (2006), Tier 3, Table 2-7, Industry, gas oil, boilers.		
			Turbines Engines	3 24	IPCC (2006), Tier 1, Table 2-3, Industry, gas oil. Nielsen et al. (2010a)		

Fuel group	Fuel	CRF source category	CRF source category	SNAP	Emission factor, g per GJ	Reference				
Kerosene	LPG	1A4a	Commercial/Institutional	0201	0.7	IPCC (2006), Tier 3, Table 2-10, Commercial, gas oil.				
				020105	24	Nielsen et al. (2010a)				
		1A4b i	Residential	0202	0.7	IPCC (2006), Tier 3, Table 2.9, Residential, gas oil.				
				020204	24	Nielsen et al. (2010a)				
		1A4c	Agriculture/Forestry	0203	0.7	IPCC (2006), Tier 3, Table 2-10, Commercial, gas oil ¹⁾ .				
				020304	24	Nielsen et al. (2010a)				
	Kerosene	Kerosene	1A2 a-g	Industry	03	3	IPCC (2006), Tier 1, Table 2-3, Industry, other kerosene.			
			1A4a	Commercial/Institutional	0201	10	IPCC (2006), Tier 1, Table 2-4, Commercial, other kerosene.			
			1A4b i	Residential	0202	10	IPCC (2006), Tier 1, Table 2-5, Residential/agricultural, other kerosene.			
			1A4c i	Agriculture/Forestry	0203	10	IPCC (2006), Tier 1, Table 2-5, Residential/agricultural, other kerosene.			
			LPG	LPG	1A1a	Public electricity and heat production	0101 0102	1	IPCC (2006), Tier 1, Table 2-2, Energy Industries, LPG.	
					1A1b	Petroleum refining	0103	1	IPCC (2006), Tier 1, Table 2-2, Energy Industries, LPG.	
1A2 a-g	Industry	03			1	IPCC (2006), Tier 1, Table 2-3, Industry, LPG				
1A4a	Commercial/Institutional	0201			5	IPCC (2006), Tier 1, Table 2-4, Commercial, LPG.				
1A4b i	Residential	0202			5	IPCC (2006), Tier 1, Table 2-5, Residential / agricultural, LPG.				
1A4c i	Agriculture/Forestry	0203			5	IPCC (2006), Tier 1, Table 2-5, Residential / agricultural, LPG.				
Refinery gas	Refinery gas	1A1b	Petroleum refining	010304	1.7	Assumed equal to natural gas fuelled gas turbines. Nielsen et al. (2010a)				
				010306	1	IPCC (2006), Tier 1, Table 2-2, refinery gas.				
GAS	Natural gas	1A1a	Public electricity and heat production	010101 010102 010103 010104	1	IPCC (2006), Tier 3, Table 2-6, Utility, natural gas, boilers.				
				010105	481	Nielsen et al. (2010a)				
				010202 010203	1	IPCC (2006), Tier 3, Table 2-6, Utility, natural gas, boilers.				
				1A1b	Petroleum refining	010306	1	Assumed equal to industrial boilers.		
				1A1c	Oil and gas extraction	010503 010504	1 1.7	Assumed equal to industrial boilers. Nielsen et al. (2010a)		
				1A2 a-g	Industry	Other	1	IPCC (2006), Tier 3, Table 2-7, Industry, natural gas boilers.		
						Gas turbines	1.7	Nielsen et al. (2010a)		
						Engines	481	Nielsen et al. (2010a)		
				1A4a	Commercial/Institutional	0201	1	IPCC (2006), Tier 3, Table 2-10, Commercial, natural gas boilers.		
						020105	481	Nielsen et al. (2010a)		
				1A4b i	Residential	0202	1	IPCC (2006), Tier 3, Table 2-9. Residential, natural gas boilers.		
						020204	481	Nielsen et al. (2010a)		
				1A4c i	Agriculture/Forestry	0203	1	IPCC (2006), Tier 3, Table 2-10, Commercial, natural gas boilers ¹⁾ .		
						020304	481	Nielsen et al. (2010a)		
				WASTE	Waste	1A1a	Public electricity and heat production	0101 0102	0.34	Nielsen et al. (2010a)
								1A2 a-g	Industry	03
						1A4a	Commercial/Institutional	0201	30	IPCC (2006), Tier 1, Table 2-3, Industry, municipal wastes ²⁾ .
						Industrial waste	1A2f	Industry	0316	30

Fuel group	Fuel	CRF source category	CRF source category	SNAP	Emission factor, g per GJ	Reference
BIO-MASS	Wood	1A1a	Public electricity and heat production	0101	3.1	Nielsen et al. (2010a)
				0102	11	IPCC (2006), Tier 3, Table 2-6, Utility boilers, wood
		1A2 a-g	Industry	03	11	IPCC (2006), Tier 3, Table 2-7, Industry, wood, boilers.
		1A4a	Commercial/Institutional	0201	11	IPCC (2006), Tier 3, Table 2-10, Commercial, wood.
		1A4b i	Residential	0202	99.01	DCE estimate based on technology distribution, Nielsen et al. (2021) ³⁾
	1A4c i	Agriculture/Forestry	0203	11	IPCC (2006), Tier 3, Table 2-10, Commercial, wood. ¹⁾	
Straw		1A1a	Public electricity and heat production	0101	0.47	Nielsen et al. (2010a)
				0102	30	IPCC (2006), Tier 1, Table 2-2, Energy industries, other primary solid biomass
		1A4b i	Residential	0202	300	IPCC (2006), Tier 1, Table 2-5, Residential, other primary solid biomass.
		1A4c i	Agriculture/ Forestry	020300	300	IPCC (2006), Tier 1, Table 2-5, Agriculture, other primary solid biomass.
				020302	30	IPCC (2006), Tier 1, Table 2-2, Energy industries, other primary solid biomass (large agricultural plants considered equal to this plant category)
Wood pellets		1A1a	Public electricity and heat production	0101	3.1	Nielsen et al. (2010a)
				0102	3	Paulrud et al. (2005)
		1A2 a-g	Industry	03	3	Paulrud et al. (2005)
		1A4a	Commercial/Institutional	0201	3	Paulrud et al. (2005)
		1A4b i	Residential	0202	3	Paulrud et al. (2005)
		1A4c i	Agriculture/Forestry	0203	3	Paulrud et al. (2005)
Bio oil		1A1a	Public electricity and heat production	010102	3	IPCC (2006), Tier 1, Table 2-2, Energy industries, biodiesels.
				010105	24	Nielsen et al. (2010a) assumed same emission factor as for gas oil fuelled engines.
				0102	3	IPCC (2006), Tier 1, Table 2-2, Energy industries, biodiesels.
		1A2 a-g	Industry	03	3	IPCC (2006), Tier 1, Table 2-3, Industry, biodiesels.
				030902	0.2	-
		1A4b i	Residential	0202	10	IPCC (2006), Tier 1, Table 2-5, Residential, biodiesels.
Biogas		1A1a	Public electricity and heat production	0101	1	IPCC (2006), Tier 1, Table 2-2, Energy industries, other biogas.
				010105	434	Nielsen et al. (2010a)
				0102	1	IPCC (2006), Tier 1, Table 2-2, Energy industries, other biogas.
		1A2 a-g	Industry	03	1	IPCC (2006), Tier 1, Table 2-3, Industry, other biogas.
				Engines	434	Nielsen et al. (2010a)
		1A4a	Commercial/Institutional	0201	5	IPCC (2006), Tier 1, Table 2-4, Commercial, other biogas.
				020105	434	Nielsen et al. (2010a)
		1A4b	Residential	0202	1	Assumed equal to natural gas.
1A4c i	Agriculture/Forestry	0203	5	IPCC (2006), Tier 1, Table 2-5, Agriculture, other biogas.		
		020304	434	Nielsen et al. (2010a)		
Bio gasification gas	1A1a	Public electricity and heat production	010101	1	Assumed equal to biogas.	
			010105	13	Nielsen et al. (2010a)	
			020105	13	Nielsen et al. (2010a)	
Bio natural gas	1A1a	Public electricity and heat production	0101	1	Assumed equal to natural gas.	
			0102			
	1A2 a-g	Industry	03	1	Assumed equal to natural gas.	

Fuel group	Fuel	CRF source category	CRF source category	SNAP	Emission factor, g per GJ	Reference
		1A4a	Commercial/Institutional	0201	1	Assumed equal to natural gas.
		1A4b	Residential	0202	1	Assumed equal to natural gas.
		1A4c	Agriculture/Forestry	0203	1	Assumed equal to natural gas.

- 1) Assumed same emission factors as for commercial plants. Plant capacity and technology are similar for Danish plants.
- 2) Assumed same emission factor as for industrial plants. Plant capacity and technology is similar to industrial plants rather than to residential plants.
- 3) Aggregated emission factor based on the technology distribution in the sector (Nielsen et al., 2021) and technology specific emission factors that refer to Paulrud et al. (2005), Johansson et al. (2004) and Olsson & Kjällstrand (2005). The emission factor is within the IPCC (2006) interval for residential wood combustion (100-900 g per GJ).

In general, the same CH₄ emission factors have been applied for 1990-2020. However, time series have been estimated for both natural gas fuelled engines and biogas fuelled engines, residential wood combustion, natural gas fuelled gas turbines¹ and waste incineration plants^{Error! Bookmark not defined.}.

Table 3A-4.4 CH₄ emission factors, time series.

Year	Natural gas fuelled engines Emission factor, g per GJ	Biogas fuelled engines Emission factor, g per GJ	Residential wood combustion, g per GJ	Waste incineration g per GJ	Natural gas fuelled gas turbines, g per GJ
1990	266	239	327	0.59	1.5
1991	309	251	321	0.59	1.5
1992	359	264	314	0.59	1.5
1993	562	276	308	0.59	1.5
1994	623	289	302	0.59	1.5
1995	632	301	296	0.59	1.5
1996	616	305	289	0.59	1.5
1997	551	310	283	0.59	1.5
1998	542	314	276	0.59	1.5
1999	541	318	270	0.59	1.5
2000	537	323	263	0.59	1.5
2001	522	342	256	0.59	1.5
2002	508	360	248	0.59	1.6
2003	494	379	240	0.59	1.6
2004	479	397	227	0.51	1.7
2005	465	416	215	0.42	1.7
2006	473	434	206	0.34	1.7
2007	481	434	197	0.34	1.7
2008	481	434	188	0.34	1.7
2009	481	434	178	0.34	1.7
2010	481	434	167	0.34	1.7
2011	481	434	160	0.34	1.7
2012	481	434	152	0.34	1.7
2013	481	434	145	0.34	1.7
2014	481	434	138	0.34	1.7
2015	481	434	131	0.34	1.7
2016	481	434	124	0.34	1.7
2017	481	434	117	0.34	1.7
2018	481	434	111	0.34	1.7
2019	481	434	105	0.34	1.7
2020	481	434	99	0.34	1.7

¹ A minor emission source.

Table 3A-4.5 N₂O emission factors and references, 2020.

Fuel group	Fuel	CRF source category	CRF source category	SNAP	Emission factor, g per GJ	Reference	
SOLID	Coal	1A1a	Public electricity and heat production	0101	0.8	Henriksen (2005)	
				0102	1.4	IPCC (2006), Tier 3, Table 2.6, Utility source, pulverised bituminous coal, wet bottom boiler.	
		1A2 a-g	Industry	03	1.5	IPCC (2006), Tier 1, Table 2-3, Manufacturing industries, coal	
		1A4b i	Residential	0202	1.5	IPCC (2006), Tier 1, Table 2-5, Residential, coal	
		1A4c i	Agriculture/Forestry	0203	1.5	IPCC (2006), Tier 1, Table 2-4, Commercial, coal ¹⁾	
	BKB	1A4b i	Residential	0202	1.5	IPCC (2006), Tier 1, Table 2-5, Residential, brown coal briquettes	
	Coke oven coke	1A2 a-g	Industry	03	1.5	IPCC (2006), Tier 1, Table 2-3, Industry, coke oven coke	
					020200	1.5	IPCC (2006), Tier 1, Table 2-5, Residential, coke oven coke
	Anodic carbon	1A2 a-g	Industry	03	1.5	IPCC (2006), Tier 1, Table 2-3, manufacturing industries, other bituminous coal	
	Fossil fly ash	1A1a	Public electricity and heat production	0101	0.8	Assumed equal to coal.	
	LIQ-UID	Petroleum coke	1A2 a-g	Industry – other	03	0.6	IPCC (2006), Tier 1, Table 2-3, Industry, petroleum coke
					031600	1.5	-
			1A4a	Commercial/Institutional	0201	0.6	IPCC (2006), Tier 1, Table 2-4, Commercial, petroleum coke
1A4b i			Residential	0202	0.6	IPCC (2006), Tier 1, Table 2-5, Residential, petroleum coke	
1A4c i			Agriculture/Forestry	0203	0.6	IPCC (2006), Tier 1, Table 2-5, Residential/Agricultural, petroleum coke	
Residual oil		1A1a	Public electricity and heat production	010101	0.3	IPCC (2006), Tier 3, Table 2-6, Utility, residual fuel oil	
					010102	5	Nielsen et al. (2010a)
					010103		
					010104	0.6	IPCC (2006), Tier 1, Table 2-2, Energy industries, residual fuel oil
					010105	0.3	IPCC (2006), Tier 3, Table 2-6, Utility, residual fuel oil
		1A1b	Petroleum refining	010306	0.6	IPCC (2006), Tier 1, Table 2-2, Energy industries, residual fuel oil	
		1A2 a-g	Industry	03	5	Nielsen et al. (2010a)	
					Engines	0.6	IPCC (2006), Tier 1, Table 2-3, manufacturing industries and construction, residual fuel oil.
	1A4a	Commercial/Institutional	0201	0.3	IPCC (2006), Tier 3, Table 2-10, Commercial, fuel oil boilers		
	1A4b i	Residential	0202	0.6	IPCC (2006), Tier 1, Table 2-5, Residential, residual fuel oil		
1A4c i	Agriculture/Forestry	0203	0.3	IPCC (2006), Tier 3, Table 2-10, Commercial, fuel oil boilers ¹⁾			
Gas oil	1A1a	Public electricity and heat production	010101	0.4	IPCC (2006), Tier 3, Table 2-6, Utility, gas oil boilers		
				010102			
				010103			
				010104	0.6	IPCC (2006), Tier 1, Table 2-2, Energy industries, gas oil	
				010105	2.1	Nielsen et al. (2010a)	
			0102	0.4	IPCC (2006), Tier 3, Table 2-6, Utility, gas oil boilers		

Fuel group	Fuel	CRF source category	CRF source category	SNAP	Emission factor, g per GJ	Reference		
		1A1b	Petroleum refining	010306	0.6	IPCC (2006), Tier 1, Table 2-2, Energy industries, gas oil		
		1A1c	Oil and gas extraction	010500	0.4	IPCC (2006), Tier 3, Table 2-6, Utility, gas oil boilers		
		1A2 a-g	Industry	03	0.4	IPCC (2006), Tier 3, Table 2-7, Industry, gas oil boilers		
				Tur-bines	0.6	IPCC (2006), Tier 1, Table 2-3, Industry, gas oil		
				Engines	2.1	Nielsen et al. (2010a)		
		1A4a	Commercial/Institutional	0201	0.4	IPCC (2006), Tier 3, Table 2-10, Commercial, gas oil boilers		
				Engines	2.1	Nielsen et al. (2010a)		
		1A4b i	Residential	0202	0.6	IPCC (2006), Tier 1, Table 2-5, Residential, gas oil		
				Engines	2.1	Nielsen et al. (2010a)		
		1A4c	Agriculture/Forestry	0203	0.4	IPCC (2006), Tier 3, Table 2-10, Commercial, gas oil boilers ¹⁾		
				Engines	2.1	Nielsen et al. (2010a)		
		Kerosene		1A2 a-g	Industry	03	0.6	IPCC (2006), Tier 1, Table 2-3, Industry, other kerosene
				1A4a	Commercial/Institutional	0201	0.6	IPCC (2006), Tier 1, Table 2-4, Commercial, other kerosene
				1A4b i	Residential	0202	0.6	IPCC (2006), Tier 1, Table 2-5, Residential, other kerosene
1A4c i	Agriculture/Forestry			0203	0.6	IPCC (2006), Tier 1, Table 2-4, Commercial, other kerosene ¹⁾		
LPG		1A1a	Public electricity and heat production	0101	0.1	IPCC (2006), Tier 1, Table 2-2, Energy industries, LPG		
				0102	0.1	IPCC (2006), Tier 1, Table 2-2, Energy industries, LPG		
		1A1b	Petroleum refining	010306	0.1	IPCC (2006), Tier 1, Table 2-2, Energy industries, LPG		
		1A2 a-g	Industry	03	0.1	IPCC (2006), Tier 1, Table 2-3, Industry, LPG		
		1A4a	Commercial/Institutional	0201	0.1	IPCC (2006), Tier 1, Table 2-4, Commercial, LPG		
		1A4b i	Residential	0202	0.1	IPCC (2006), Tier 1, Table 2-5, Residential, LPG		
1A4c i	Agriculture/Forestry	0203	0.1	IPCC (2006), Tier 1, Table 2-5, Residential/Agricultural, LPG				
				IPCC (2006), Tier 1, Table 2-5, Residential/Agricultural, LPG				
Refinery gas		1A1b	Petroleum refining	010304	1	Assumed equal to natural gas fuelled turbines. Based on Nielsen et al. (2010a).		
				010306	0.1	IPCC (2006), Tier 1, Table 2-2, Energy industries, refinery gas		
GAS	Natural gas	1A1a	Public electricity and heat production	010101	1	IPCC (2006), Tier 3, Table 2-6, Natural gas, Utility, boiler		
				010102				
				010103				
				010104			1	Nielsen et al. (2010a)
				010105			0.58	Nielsen et al. (2010a)
		1A1b	Petroleum refining	010306	1	IPCC (2006), Tier 3, Table 2-6, Natural gas, Utility, boiler		
						IPCC (2006), Tier 3, Table 2-6, Natural gas, Utility, boiler		
		1A1c	Oil and gas extraction	010504	1	Nielsen et al. (2010a)		
		1A2 a-g	Industry	03	1	IPCC (2006), Tier 3, Table 2-7, Industry, natural gas boilers		
						Gas turbines	1	Nielsen et al. (2010a)
						Engines	0.58	Nielsen et al. (2010a)
1A4a	Commercial/Institutional	020100	1	IPCC (2006), Tier 3, Table 2-10, Commercial, natural gas boilers				
020103								

Fuel group	Fuel	CRF source category	CRF source category	SNAP	Emission factor, g per GJ	Reference
				Engines	0.58	Nielsen et al. (2010a)
		1A4b i	Residential	0202	1	IPCC (2006), Tier 3, Table 2-9, Residential, natural gas boilers
				Engines	0.58	Nielsen et al. (2010a)
		1A4c i	Agriculture/Forestry	0203	1	IPCC (2006), Tier 3, Table 2-10, Commercial, natural gas boilers ¹⁾
				Engines	0.58	Nielsen et al. (2010a)
WASTE	Waste	1A1a	Public electricity and heat production	0101 0102	1.2	Nielsen et al. (2010a)
		1A2 a-g	Industry	03	4	IPCC (2006), Tier 1, Table 2-3, Industry, wastes
		1A4a	Commercial/Institutional	0201	4	IPCC (2006), Tier 1, Table 2-4, Commercial, municipal wastes
	Industrial waste	1A2 a-g	Industry	03	4	IPCC (2006), Tier 1, Table 2-3, Industry, industrial wastes
BIO-MASS	Wood	1A1a	Public electricity and heat production	0101 0102	0.8 4	Nielsen et al. (2010a) IPCC (2006), Tier 1, Table 2-2, Energy industries, wood
		1A2 a-g	Industry	03	7	IPCC (2006), Table 2-7 Industrial source emission factors, wood / wood waste boilers
		1A4a	Commercial/Institutional	0201	4	IPCC (2006), Tier 1, Table 2-4, Commercial, wood
		1A4b i	Residential	0202	4	IPCC (2006), Tier 1, Table 2-5, Residential, wood
		1A4c i	Agriculture/Forestry	0203	4	IPCC (2006), Tier 1, Table 2-5, Agriculture, wood
	Straw	1A1a	Public electricity and heat production	0101 0102	1.1 4	Nielsen et al. (2010a) IPCC (2006), Tier 1, Table 2-2, Energy industries, other primary solid biomass
		1A4b i	Residential	0202	4	IPCC (2006), Tier 1, Table 2-5, Residential, other primary solid biomass
		1A4c i	Agriculture/Forestry	0203	4	IPCC (2006), Tier 1, Table 2-5, Agriculture, other primary solid biomass
	Wood pellets	1A1a	Public electricity and heat production	0101 0102	0.8 4	Nielsen et al. (2010a) IPCC (2006), Tier 1, Table 2-2, Energy industries, wood
		1A2 a-g	Industry	03	4	IPCC (2006), Tier 1, Table 2-3, Industry, wood
		1A4a	Commercial/Institutional	0201	4	IPCC (2006), Tier 1, Table 2-4, Commercial, wood
		1A4b i	Residential	0202	4	IPCC (2006), Tier 1, Table 2-5, Residential, wood
	Bio oil	1A1a	Public electricity and heat production	0101 0102 Engines	0.6 2.1	IPCC (2006), Tier 3, Table 2-2, Utility, biodiesels Assumed equal to gas oil. Based on Nielsen et al. (2010a)
		1A2 a-g	Industry	03	0.4	Assumed equal to gas oil.
		1A4b i	Residential	0202	0.6	IPCC (2006), Tier 1, Table 2-5, Residential, biodiesels
	Biogas	1A1a	Public electricity and heat production	0101 0102 Engines	0.1 1.6	IPCC (2006), Tier 1, Table 2-2, Energy industries, other biogas Nielsen et al. (2010a)
		1A2 a-g	Industry	03	0.1	IPCC (2006), Tier 1, Table 2-3, Industry, other biogas

Fuel group	Fuel	CRF source category	CRF source category	SNAP	Emission factor, g per GJ	Reference
				Engines	1.6	Nielsen et al. (2010a)
		1A4a	Commercial/Institutional	0201	0.1	IPCC (2006), Tier 1, Table 2.4, Commercial, other biogas
				Engines	1.6	Nielsen et al. (2010a)
		1A4b	Residential	0202	1	Assumed equal to natural gas.
		1A4c i	Agriculture/Forestry	0203	0.1	IPCC (2006), Tier 1, Table 2-5, Agriculture, other biogas
				Engines	1.6	Nielsen et al. (2010a)
Bio gasification gas		1A1a	Public electricity and heat production	010101	0.1	Assumed equal to biogas.
				010105	2.7	Nielsen et al. (2010a)
		1A4a	Commercial/Institutional	020105	2.7	Nielsen et al. (2010a)
Bio natural gas		1A1a	Public electricity and heat production	0101 or 0102	1	Assumed equal to natural gas.
		1A2 a-g	Industry	03	1	Assumed equal to natural gas.
		1A4a	Commercial/Institutional	0201	1	Assumed equal to natural gas.
		1A4b	Residential	0202	1	Assumed equal to natural gas.
		1A4c	Agriculture/Forestry	0203	1	Assumed equal to natural gas.

1) In Denmark, plants in Agriculture/Forestry are similar to Commercial plants.

Time series have been estimated for natural gas fuelled gas turbines and refinery gas fuelled turbines. All other emission factors have been applied unchanged for 1990-2020.

Table 3A-4.6 N₂O emission factors, time series.

Year	Natural gas fuelled gas turbines. Emission factor, g per GJ	Refinery gas fuelled gas turbines. Emission factor, g per GJ
1990	2.2	2.2
1991	2.2	2.2
1992	2.2	2.2
1993	2.2	2.2
1994	2.2	2.2
1995	2.2	2.2
1996	2.2	2.2
1997	2.2	2.2
1998	2.2	2.2
1999	2.2	2.2
2000	2.2	2.2
2001	2.0	2.0
2002	1.9	1.9
2003	1.7	1.7
2004	1.5	1.5
2005	1.4	1.4
2006	1.2	1.2
2007	1.0	1.0
2008	1.0	1.0
2009	1.0	1.0
2010	1.0	1.0
2011	1.0	1.0
2012	1.0	1.0
2013	1.0	1.0
2014	1.0	1.0
2015	1.0	1.0
2016	1.0	1.0
2017	1.0	1.0
2018	1.0	1.0
2019	1.0	1.0
2020	1.0	1.0

Table 3A-4.15 Technology specific CH₄ emission factors for residential wood combustion.

Technology	Emission factor, g per GJ	Reference
Stoves (-1989)	430	Methane emissions from residential biomass combustion, Paulrud et al. (2005) (SMED report, Sweden)
Stoves (1990-2007)	215	Assumed ½ the emission factor for stoves (-1989).
Stoves (2008-2014)	125	Estimated based on the emission factor for stoves (1990-2007) and the emission factors for NMVOC.
Stoves (2015-2016)	125	Same as stoves (2008-2014)
Stoves (2017-)	125	Same as stoves (2008-2014)
Eco labelled stoves / new advanced stoves (-2014)	2	Low emissions from wood burning in an ecolabelled residential boiler. Olsson & Kjällstrand (2005).
Eco labelled stoves / new advanced stoves (2015-2016)	2	Same as advanced/ecolabelled stoves
Eco labelled stoves / new advanced stoves (2017-)	2	Same as advanced/ecolabelled stoves
Open fireplaces and similar	430	Assumed equal to stoves (-1989).
Masonry heat accumulating stoves and similar	215	Assumed equal to stoves (-1989).
Boilers with accumulation tank (-1979)	211	Methane emissions from residential biomass combustion, Paulrud et al 2005 (SMED report, Sweden)
Boilers without accumulation tank (-1979)	256	Methane emissions from residential biomass combustion, Paulrud et al 2005 (SMED report, Sweden)
Boilers with accumulation tank (1980-)	50	Emission characteristics of modern and old-type residential boilers fired with wood logs and wood pellets. Johansson et al. (2004)
Boilers without accumulation tank (1980-)	50	Emission characteristics of modern and old-type residential boilers fired with wood logs and wood pellets. Johansson et al. (2004)

Annex 3A-5 Large point sources

Table 3A-5.1 Large point sources, 2020 (stationary combustion).

Large point sources

AffaldPlus+, Naestved Forbraendingsanlaeg
Affaldplus+, Slagelse Forbr. and DONG Slagelse KVV
Affaldscenter aarhus - Forbraendsanlaegget
Amagerforbraending
Amagervaerket
Ardagh Glass Holmegaard A/S
Asnaesvaerket
Avedoerevaerket
AVV Forbraendingsanlaeg
Bofa I/S
Cheminova
Dalum Kraftvarmevaerk
Danisco Grindsted Dupont
DanSteel
Duferco Danish Steel
Enstedvaerket
Esbjergvaerket
Faxe Kalk
Fjernvarme Fyn, Centrum Varmecentral
Frederikshavn Affaldskraftvarmevaerk
Fynsvaerket
H.C.Oerstedsvaerket
Haldor Topsoee
Hammel Fjernvarmeselskab
Herningvaerket
Horsens Kraftvarmevaerk
I/S Faelles Forbraending
I/S Kara Affaldsforbraendingsanlaeg
I/S Kraftvarmevaerk Thisted
I/S Nordforbraending
I/S Reno Nord
I/S Reno Syd
I/S Vestforbraending
Koege Kraftvarmevaerk
Kolding Forbraendingsanlaeg TAS
Kommunekemi
Kyndbyvaerket
L90 Affaldsforbraending
Maricogen
Nordic Sugar Nakskov
Nordic Sugar Nykoebing
Nordjyllandsvaerket
Nybro Gasbehandlingsanlaeg
Odense Kraftvarmevaerk
Oestkraft
Randersvaerket Verdo
Rensningsanlaegget Lynetten
Rockwool A/S Doense
Rockwool A/S Vamdrup
Saint-Gobain Isover A/S
Shell Raffinaderi
Skaerbaekvaerket
Soenderborg Kraftvarmevaerk
Statoil Raffinaderi
Studstrupvaerket
Svanemoellevaerket
Svendborg Kraftvarmevaerk
Viborg Kraftvarme
Vordingborg Kraftvarme
Aalborg Portland
AarhusKarlshamn Denmark A/S

Table 3A-5.2 Large point sources, aggregated fuel consumption in 2020.

nfr_id_EA	fuel_id	fuel_gr_abbr	Fuel, TJ
1A1a	102A	COAL	28780
	103A	SUB-BITUMINOUS	46
	111A	WOOD	25703
	114A	WASTE	37873
	117A	STRAW	4628
	122A	Wood Pellets	27984
	203A	RESIDUAL OIL	791
	204A	GAS OIL	508
	215A	BIO OIL	10
	301A	NATURAL GAS	8140
	303A	LPG	1
	309A	BIOGAS	146
1A1a Total			134611
1A1b	203A	RESIDUAL OIL	106
	204A	GAS OIL	3
	301A	NATURAL GAS	622
	303A	LPG	0
	308A	REFINERY GAS	15316
1A1b Total			16048
1A1c	204A	GAS OIL	0
	301A	NATURAL GAS	93
1A1c Total			93
1A2a	204A	GAS OIL	0
	301A	NATURAL GAS	1646
	303A	LPG	2
1A2a Total			1648
1A2c	204A	GAS OIL	0
	301A	NATURAL GAS	1180
	303A	LPG	1
1A2c Total			1181
1A2e	102A	COAL	442
	107A	COKE OVEN COKE	110
	111A	WOOD	618
	203A	RESIDUAL OIL	2149
	204A	GAS OIL	21
	215A	BIO OIL	79
	301A	NATURAL GAS	327
	303A	LPG	40
309A	BIOGAS	108	
1A2e Total			3894
1A2f	102A	COAL	3151
	107A	COKE OVEN COKE	224
	110A	PETROLEUM COKE	7534
	111A	WOOD	737
	115A	INDUSTR. WASTES	3409
	203A	RESIDUAL OIL	69
	204A	GAS OIL	79
	215A	BIO OIL	0
	301A	NATURAL GAS	1594
	303A	LPG	112
	1A2f Total		
1A4a i	111A	WOOD	220
	114A	WASTE	0
	309A	BIOGAS	0
1A4a i Total			220
Grand Total			174602

Annex 3A-6 Adjustment of CO₂ emission

Table 3A-6.1 Adjustment of CO₂ emission (DEA, 2021a).

		1990	1991	1992	1993	1994	1995	1996	1997	1998	1999
Actual Degree Days	Degree days	2857	3284	3022	3434	3148	3297	3837	3236	3217	3056
Normal Degree Days	Degree days	3379	3380	3359	3365	3366	3378	3395	3389	3375	3339
Net electricity import	PJ	25.4	-7.1	13.5	4.3	-17.4	-2.9	-55.4	-26.1	-15.6	-8.3
Actual CO ₂ emission	1 000 000 tonnes	38.4	47.9	42.0	44.3	47.8	44.6	57.6	47.8	43.9	40.6
Adjusted CO ₂ emission	1 000 000 tonnes	44.6	46.3	44.9	45.4	44.0	43.9	44.6	41.9	40.2	38.7
Continued		2000	2001	2002	2003	2004	2005	2006	2007	2008	2009
Actual Degree Days	Degree days	2902	3279	3011	3150	3113	3068	2908	2807	2853	3061
Normal Degree Days	Degree days	3304	3289	3273	3271	3261	3224	3188	3136	3120	3127
Net electricity import	PJ	2.4	-2.1	-7.5	-30.8	-10.3	4.9	-25.0	-3.4	5.2	1.2
Actual CO ₂ emission	1 000 000 tonnes	36.7	38.2	37.7	42.5	36.5	32.8	40.5	35.1	32.3	31.4
Adjusted CO ₂ emission	1 000 000 tonnes	37.3	37.9	36.2	35.7	34.3	34.0	34.9	34.3	33.5	31.7
Continued		2010	2011	2012	2013	2014	2015	2016	2017	2018	2019
Actual Degree Days	Degree days	3742	2970	3234	3207	2664	2921	2998	2970	2900	2847
Normal Degree Days	Degree days	3171	3156	3166	3155	3131	3112	3070	3057	3041	3030
Net electricity import	PJ	-4.1	4.7	18.8	3.9	10.3	21.3	18.2	16.4	18.8	20.9
Actual CO ₂ emission	1 000 000 tonnes	31.9	27.1	23.6	25.5	21.3	18.7	20.1	17.5	17.4	14.1
Adjusted CO ₂ emission	1 000 000 tonnes	31.0	28.2	27.8	26.2	23.1	22.3	23.1	20.2	20.4	17.2
Continued		2020									
Actual Degree Days	Degree days	2715									
Normal Degree Days	Degree days	3021									
Net electricity import	PJ	24.8									
Actual CO ₂ emission	1 000 000 tonnes	12.3									
Adjusted CO ₂ emission	1 000 000 tonnes	15.4									

Annex 3A-7 Uncertainty estimates

Table 3A-7.1 Uncertainty estimation, approach 1, GHG

This table is available at: <https://envs.au.dk/en/faglige-omraader/luffforurening-udledninger-og-effekter/udledning-af-luffforurening/greenhouse-gases/supporting-documentation>

Table 3A-7.2 Uncertainty estimation, approach 1, CO₂

This table is available at: <https://envs.au.dk/en/faglige-omraader/luffforurening-udledninger-og-effekter/udledning-af-luffforurening/greenhouse-gases/supporting-documentation>

Table 3A-7.3 Uncertainty estimation, approach 1, CH₄

This table is available at: <https://envs.au.dk/en/faglige-omraader/luffforurening-udledninger-og-effekter/udledning-af-luffforurening/greenhouse-gases/supporting-documentation>

Table 3A-7.4 Uncertainty estimation, approach 1, N₂O

This table is available at: <https://envs.au.dk/en/faglige-omraader/luffforurening-udledninger-og-effekter/udledning-af-luffforurening/greenhouse-gases/supporting-documentation>

Annex 3A-8 Emission inventory 2020 based on SNAP sectors

Table 3A-8.1 Emission inventory 2020 based on SNAP sectors.

CRF	SNAP	CO ₂ , kt	CH ₄ , t	N ₂ O, t
1A1a	010100	0.0	1.5	1.5
	010101	2925.8	108.6	46.5
	010102	988.1	79.4	53.3
	010103	432.4	8.2	15.2
	010104	449.2	39.1	17.2
	010105	159.9	2744.4	11.0
	010200	0.0	1.6	1.6
	010201	0.0	0.0	0.0
	010202	82.3	1.5	1.4
	010203	335.6	337.0	87.2
	010205	0.0	0.0	0.0
1A1a Total		5373.3	3321.3	235.0
1A1b	010304	114.4	3.3	1.9
	010306	801.4	14.3	2.0
1A1b Total		915.8	17.6	4.0
1A2	030104	0.0	0.0	0.0
	030105	0.0	0.0	0.0
	030106	3.6	0.1	0.1
	030400	2.2	0.0	0.0
	030402	91.5	1.6	1.6
	030500	0.0	0.0	0.0
	030600	138.5	2.5	2.5
	030602	36.3	0.7	0.7
	030603	0.0	0.0	0.0
	030604	29.2	0.9	0.5
	030605	0.0	46.2	0.2
	030700	182.8	4.0	2.9
	030701	73.7	4.0	59.9
	030702	41.5	0.8	0.7
	030703	8.4	0.9	0.1
	030705	0.2	2.1	0.0
	030706	99.0	9.2	1.6
	030800	47.7	3.9	3.0
	030900	591.5	14.3	10.3
	030902	122.3	11.1	8.9
	030903	122.6	4.5	5.5
	030904	15.5	0.5	0.3
	030905	17.3	561.0	1.7
	031000	9.0	0.4	0.3
	031005	0.0	0.0	0.0
	031100	55.2	3.6	2.8
	031102	0.0	0.0	0.0
	031103	0.0	0.8	0.5
	031104	0.0	0.0	0.0
	031200	7.8	0.3	0.2
	031205	0.0	0.0	0.0
	031300	111.9	2.5	2.5
	031305	2.4	20.5	0.0
	031400	6.0	13.5	10.3
	031403	0.0	2.2	1.4
	031405	0.1	0.8	0.0
031500	25.2	0.5	0.4	
031600	1112.9	153.6	31.3	
031604	0.0	0.0	0.0	
031605	0.0	0.0	0.0	
032000	2.8	8.1	7.1	
032002	0.0	0.0	0.0	
032004	0.0	0.0	0.0	
032005	0.1	19.3	0.1	
1A2 Total		2957.4	894.2	157.6

CRF	SNAP	CO ₂ , kt	CH ₄ , t	N ₂ O, t
1A1c_ii	010500	24.3	0.3	0.1
	010503	5.1	0.1	0.1
	010504	872.3	25.8	15.2
	010505	0.0	0.0	0.0
1A1c_ii Total		901.8	26.2	15.4
1A4a_i	020100	503.8	17.0	14.6
	020103	1.9	3.3	0.9
	020105	3.1	358.8	1.3
1A4a_i Total		508.7	379.0	16.8
1A4b_i	020200	1516.1	2443.9	160.4
	020202	2.5	0.1	0.1
	020204	4.3	36.9	0.0
1A4b_i Total		1522.9	2480.8	160.5
1A4c_i	020300	141.3	575.4	10.4
	020302	0.0	0.0	0.0
	020303	0.0	0.0	0.0
	020304	11.9	397.6	1.2
	020305	0.0	0.0	0.0
1A4c_i Total		153.2	973.0	11.6
Grand Total		12333.1	8092.3	600.8

Annex 3A-9 EU ETS data for coal

EU ETS data are available for the years 2006-2019. Corresponding values for lower calorific value (LCV) and implied emission factor (IEF) for CO₂ for 2006-2009 are shown in Figure 3A-9.1. The IEF factors include the oxidation factors.

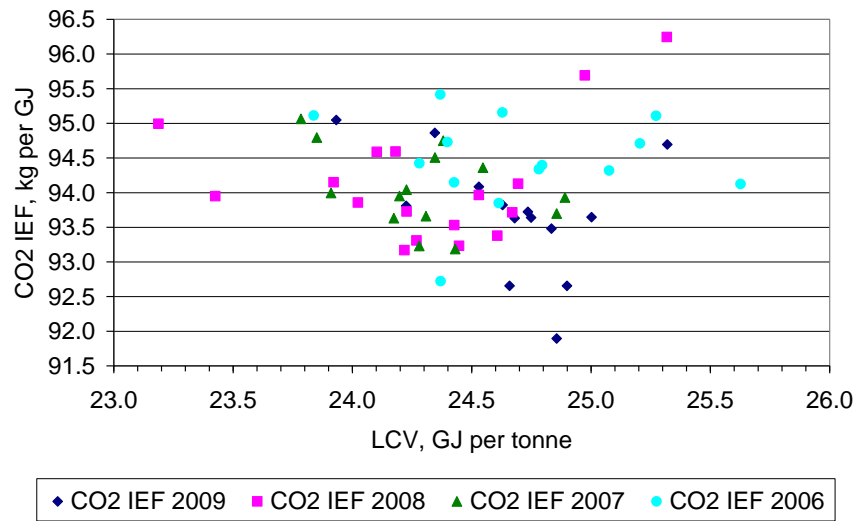

Figure 3A-9.1 EU ETS data for LCV and CO₂ IEF (including oxidation factor) for coal. Data for the years 2006-2009.

Annex 3B - Transport and other mobile sources

- Annex 3B-1: Fleet data 1985-2020 for road transport (No. vehicles)
- Annex 3B-2: Mileage data 1985-2020 for road transport (km)
- Annex 3B-3: EU directive emission limits for road transportation vehicles
- Annex 3B-4: Basis fuel consumption and emission factors (g pr km) for conventional vehicles and PHEV (gasoline), fuel consumption factors for electric, PHEV (el) and hydrogen vehicles
- Annex 3B-6: Deterioration factors in 2020
- Annex 3B-7: Final fuel consumption factors (MJ/km) and emission factors (g/km) for conventional vehicles and PHEV (gasoline), fuel consumption factors for electric, PHEV (el) and hydrogen vehicles in 2020, for urban/rural/highway and weighted traffic
- Annex 3B-8: Fuel consumption (GJ) and emissions (tonnes) per vehicle category and as totals
- Annex 3B-9: Model consumption: Fuel sales derived fuel and emission adjustment factors
- Annex 3B-10-1: Correspondence table between actual aircraft type codes and representative aircraft types
- Annex 3B-10-2: LTO no. and average LTO fuel consumption and emission factors per representative aircraft type for domestic and international flights (Copenhagen and other airports)
- Annex 3B-10-3: No. of flights between Danish airports and airports in Greenland and Faroe Islands
- Annex 3B-10-4: Total distance flown (NM) and average cruise fuel consumption and emission factors per representative aircraft type for cruise flying
- Annex 3B-10-5: LTO times-in-modes (s) for the Danish airports
- Annex 3B-10-6: APU Engine mode specific fuel flows (kg/h), emission rates (kg/h or g/kg) and times-in-modes per aircraft type
- Annex 3B-11-1: Stock data for diesel tractors 1985-2020
- Annex 3B-11-2: Stock data for gasoline tractors 1985-2005
- Annex 3B-11-3: Stock data for harvesters 1985-2020
- Annex 3B-11-4: Stock data for fork lifts 1985-2020
- Annex 3B-11-6: Stock data for construction machinery 1985-2020
- Annex 3B-11-7: Stock data for machine pools 1985-2020
- Annex 3B-11-8: Stock data for household and gardening machinery 1985-2020
- Annex 3B-11-9: Stock data for recreational craft 1985-2020
- Annex 3B-11-10: Stage V Emission Standards for Nonroad Engines
- Annex 3B-11-11: Engine size, annual working hours (0 year engines), load factors and maximum lifetime for building and construction machinery
- Annex 3B-11-12: Engine size, annual working hours (0 year engines), load factors and maximum lifetime for gasoline fueled working machinery
- Annex 3B-12-1: Annual traffic data (no. of round trips) per route for Danish ferries 1990-2020
- Annex 3B-12-2: Annual traffic data (no. of round trips) per route per ferry for Danish ferries 1990-2020
- Annex 3B-12-3: Round trip shares per route per ferry for Danish ferries 1990-2020
- Annex 3B-12-4: Sailing time (single trip) per route per ferry for Danish ferries 1990-2020
- Annex 3B-12-5: Engine load factor (% MCR) per route per ferry for Danish ferries 1990-2020
- Annex 3B-12-6: Ferry service, ferry name, engine type, engine year, fuel type, main engine MCR (kW), aux. engine (kW), engine load factors (%), Number of round trips, Sailing time (mins), MWh produced, fuel

consumption (tons and GJ), specific fuel consumption (g/kWh), SO₂, NO_x, NMVOC, CH₄, VOC, CO, CO₂, N₂O, NH₃, TSP, PM₁₀, PM_{2.5} and BC emission factors for 2020 (g/kWh, g/GJ, g/kg fuel).

Annex 3B-12-7: Hours at sea, engine load (%), MWh produced, fuel consumption (PJ), specific fuel consumption (g/kWh), SO₂, NO_x, NMVOC, CH₄, VOC, CO, CO₂, N₂O, NH₃, TSP, PM₁₀, PM_{2.5} and BC emission factors (g/kWh, g/GJ, g/kg fuel) for Danish fishing vessels 1985-2020 distributed into overall length classes.

Annex 3B-13-1: Specific fuel consumption, NO_x, CO, VOC, NMVOC and CH₄ emission factors (g pr kWh) per engine year for marine engines

Annex 3B-13-2: Fuel consumption (PJ and tonnes), S-%, SO₂, NO_x, NMVOC, CH₄, CO, CO₂, N₂O, TSP, PM₁₀, PM_{2.5} and BC emission factors (g/kg fuel and g/GJ) per fuel type for national sea transport, international sea transport and fisheries

Annex 3B-13-3: Engine load adjustment functions for sfc, NO_x, VOC, CO, N₂O and TSP emission factors for marine engines

Annex 3B-14-1: Fuel sales figures from DEA, and further processed fuel consumption data suited for the Danish inventory

Annex 3B-14-2: Fuel sulphur legislation limits, fuel sulphur content and lower heating values used in the Danish inventory

Annex 3B-15-1: Emission factors for 1990 in CollectER format

Annex 3B-15-2: Emission factors for 2020 in CollectER format

Annex 3B-15-3: Emissions for 1990 in CollectER format

Annex 3B-15-4: Emissions for 2020 in CollectER format

Annex 3B-15-5: Non-exhaust emission factors, activity data and total non-exhaust emissions of TSP, PM₁, PM_{2.5}, BC and heavy metals in 2020

Annex 3B-16-1: Fuel consumption 1985-2020 in CRF format

Annex 3B-16-2: Emissions 1985-2020 in CRF format

Annex 3B-16-3: Fuel consumption 1985-2020 in NFR format

Annex 3B-16-4: Emissions 1985-2020 in NFR format

Annex 3B-17-1: Uncertainty estimates for greenhouse gases

Annex 3B-17-2: Uncertainty estimates for emission components reported to the LRTAP Convention

All annexes are available at:

<https://envs.au.dk/en/faglige-omraader/luftforurening-udledninger-og-effekter/udledning-af-luftforurening/greenhouse-gases/supporting-documentation>

Annex 3C - Industrial processes and product use

Annex 3C-1:	Production statistics for cement and clinker production, kt
Annex 3C-2:	Implied emission factors for CO ₂ for cement production
Annex 3C-3:	Emission of CO ₂ from cement production, kt
Annex 3C-4:	Production of burnt lime, kt
Annex 3C-5:	Emission of CO ₂ from lime production, kt
Annex 3C-6:	Production of container/art glass, kt
Annex 3C-7:	Production of glass wool, kt
Annex 3C-8:	Statistics for production of bricks/tiles and expanded clay products
Annex 3C-9:	CO ₂ emissions from the production of ceramics, kt
Annex 3C-10:	Statistics of other uses of soda ash, kt
Annex 3C-11:	CO ₂ emissions from other uses of soda ash, kt
Annex 3C-12:	Activity data for flue gas desulphurisation, kt
Annex 3C-13:	CO ₂ emissions from flue gas desulphurisation, kt
Annex 3C-14:	Activity data for stone wool production, kt CaCO ₃ equivalents
Annex 3C-15:	Emissions from stone wool production, kt
Annex 3C-16:	Production of nitric acid, kt
Annex 3C-17:	N ₂ O emissions from nitric acid production, kt
Annex 3C-18:	Production of catalysts and potassium nitrate
Annex 3C-19:	CO ₂ emissions from production of catalysts, kt
Annex 3C-20:	Overall mass flow for Danish steel production, kt
Annex 3C-21:	CO ₂ emissions from steel production, kt
Annex 3C-22:	Activity data for secondary lead production, t
Annex 3C-23:	CO ₂ emissions from secondary lead production, kt
Annex 3C-24:	Consumption of lubricant oil

Annex 3C-25:	CO ₂ emissions from consumption of lubricants, kt
Annex 3C-26:	Use of paraffin wax candles, kt
Annex 3C-27:	Emissions from the use of paraffin wax candles
Annex 3C-28:	Activity data for solvent use, kt
Annex 3C-29:	CO ₂ emission factors for solvent use
Annex 3C-30:	CO ₂ emissions from solvent use
Annex 3C-31:	Activity data for road paving with asphalt, kt
Annex 3C-32:	Emissions from road paving with asphalt, t
Annex 3C-33:	Activity data for asphalt roofing, kt
Annex 3C-34:	Emissions from asphalt roofing, t
Annex 3C-35:	Activity data for urea used in catalysts, kt
Annex 3C-36:	Emissions from urea used in catalysts, kt
Annex 3C-37:	Consumption of F-gasses in other electronic industry, t
Annex 3C-38:	Emissions from other electronic industry, kt CO ₂ equivalents
Annex 3C-39:	Consumption of cream in Denmark, t
Annex 3C-40:	Emissions from the use of canned whipped cream, kt
Annex 3C-41:	Activity data for other product uses, kt
Annex 3C-42:	Emissions from other product uses, kt

All annexes are available at:

<https://envs.au.dk/en/faglige-omraader/luftforurening-udledninger-og-effekter/udledning-af-luftforurening/greenhouse-gases/supporting-documentation>

Please note that data found via this link are updated annually. This means that data in the annexes always matches the newest version of the NIR report.

Annex 3D - Agriculture

Table 3D-1 Changes in housing type 1990 – 2020

Table 3D-2 Number of animals allocated on subcategories for 1990-2020, 1000 head.

Table 3D-3 (a-d) NH₃ emission factors for housing units, 2020.

Table 3D-4 NH₃ emission factors for storage units, 2020.

Table 3D-5 EF for poultry for CH₄ from enteric fermentation, kg CH₄ per 100 or 1000 heads.

Table 3D-6 Parameters for winter-feeding plans.

Table 3D-7 Energy factors used for GE.

Table 3D-8 Feed intake 1990-2020, Dairy cattle; kg DM per cow per year, Others; FU per animal per year.

Table 3D-9 Grazing animals 1990 – 2020, number of days on grass per year.

Table 3D-10 Gross energy per kg DM for dairy cattle, 1990-2020, MJ per kg DM.

Table 3D-11 Average gross energy intake (GE) 1990 – 2020, MJ per head per day.

Table 3D-12 Implied Emission Factor for CH₄ from enteric fermentation, 1990-2020, kg CH₄ per head per day

Table 3D-13 Emission of CH₄ from enteric fermentation, 1990 – 2020, kt CH₄

Table 3D-14 VS daily excretion 1990 – 2020, kg DM per head per day.

Table 3D-15 National manure management system and MCF vs. IPCC manure management system and MCF

Table 3D-16 MCF for liquid manure, 1990 – 2020.

Table 3D-17 Implied Emission Factor of CH₄ from manure management, 1990 – 2020, kg CH₄ per head per day

Table 3D-18 Emission of CH₄ from manure management, 1990-2020, kt CH₄

Table 3D-19 Area of agricultural land, 1990 – 2020, ha

Table 3D-20 Above-ground residue dry matter AG_{DM(T)} 1990-2020, kg DM per ha.

Figure 3D-1 Model calculation of nitrogen leaching from groundwater nationwide by SKEP/DAISY and N-LES.

Table 3D-21 QA/QC procedure, stage I – III

Chapter 3D-1 Biogas treatment of manure

Table 3D-1 Changes in housing type 1990 – 2020. <https://envs.au.dk/en/faglige-omraader/luffforurening-udledninger-og-effekter/udledning-af-luffforurening/greenhouse-gases/supporting-documentation> (most recently submitted values)

Table 3D-2 Number of animals allocated on subcategories for 1990-2020, 1 000 head. <https://envs.au.dk/en/faglige-omraader/luffforurening-udledninger-og-effekter/udledning-af-luffforurening/greenhouse-gases/supporting-documentation> (most recently submitted values)

Table 3D-3 (a-d) NH₃ emission factors for housing units, 2020.

a) **Cattle**

Housing type		Urine	Slurry	Solid manure	Deep litter manure
		TAN	TAN	Total N	Total N
		pct. loss of TAN ex animal		pct. loss of N ex animal	
Tethered	urine and solid manure	6	-	5	-
	slurry manure	-	6	-	-
Loose-housing with beds	solid floor	-	20	-	-
	slatted floor	-	13.5	-	-
	slatted floor and scrape	-	12	-	-
	drained floor	-	10.4	-	-
	solid floor with tilt	-	10.4	-	-
Deep litter	All	-	-	-	6
	solid floor	-	-	-	6
	slatted floor	-	13.5	-	6
	slatted floor and scrape	-	12	-	6
	solid floor and scrape	-	20	-	6
Boxes	sloping bedded floor	-	16	-	-
	slatted floor	-	16	-	-

Continued...

b) Swine

			Urine TAN	Slurry TAN	Solid manure Total N	Deep litter Total N
Housing type	Floor or manure type	Pct. loss of TAN ex animal	pct. loss of N ex animal			
<u>Sows</u>	Individual, mating and gestation	Partly slatted floor	-	13	-	-
		Full slatted floor	-	19	-	-
		Solid floor	21	-	16	-
	Group, mating and gestation	Deep litter	-	-	-	15
		Deep litter + slatted floor	-	16	-	15
		Deep litter + solid floor	-	19	-	15
		Partly slatted floor	-	16	-	-
	Organic production	Deep litter	-	16	-	15
		Farrowing crate	-	26	-	-
	Farrowing pen	Partly slatted floor	-	13	-	-
		Solid floor	20	-	15	-
	Partly slatted floor	-	22	15	-	
<u>Weaners</u>	Full slatted floor	-	24	-	-	
	Drained + partly slatted floor	-	21	-	-	
	Deep litter (to-climate housings)	-	10	-	15	
	Solid floor	37	-	25	-	
	Deep litter	-	-	-	15	
	Organic production	Deep litter	-	15	-	15
<u>Fattening pigs</u>	Partly slatted floor (50-75 % solid)	-	13	-	-	
	Partly slatted floor (25-49% solid)	-	17	-	-	
	Drained + partly slatted floor	-	21	-	-	
	Full slatted floor	-	24	-	-	
	Solid floor	27	-	18	-	
	Deep litter, divided	-	18	-	15	
	Deep litter	-	-	-	15	
	Organic production	Partly slatted floor	-	38	-	-

c) Poultry

			Solid manure Total N	Deep litter Total N
Housing type	Floor or manure type	pct. loss of N ex animal		
Hens and pullets	Free-range, organic and barn	Deep pit	40	25
		Deep litter	-	28
		Manure belt	10	25
	Battery	Deep pit	12	-
		Manure belt	10	-
Broilers	Conventional	Deep litter	-	10
	Organic and barn	Deep litter	-	13
Turkeys, ducks and geese	Deep litter	-	20	

Continued...

d) Other

	Slurry TAN	Deep litter Total N
	Pct. loss of TAN ex animal	pct. loss of N ex animal
Fur animals	30-67	40
Horses, sheep and goats	-	15

Table 3D-4 NH₃ emission factors for storage units, 2020.

		Urine	Slurry	Solid manure	Deep litter	Pct. of solid manure stored in heap on field	
Cattle	Total N	2.2	2	4	1	35	
	TAN	2.2	3.4	-	-	-	
Pigs	Sows	Total N	2.2	2.1	19	6.5	50
		TAN	2.2	2.7	-	-	-
	Weaners	Total N	2.2	2.1	19	9.8	-
		TAN	2.2	2.7	-	-	-
	Fattening pigs	Total N	2.2	2.1	19	9.8	75
		TAN	2.2	2.7	-	-	-
Poultry	Hens and pullets	Total N	-	2	7.5	4.8	95
		TAN	-	-	11.5	6.8	85
	Turkeys, ducks, and geese	Total N	-	-	-	6.8, 8(Tur- keys)	-
Ostric	Total N	-	-	-	4.8	-	
Fur animals	Total N	0	1.9	-	8	-	
	TAN	0	2.7	-	-	-	
Sheep and goats	Total N	-	-	-	3	-	
Horses	Total N	-	-	-	3	-	

Table 3D-5 EF for poultry for CH₄ from enteric fermentation, kg CH₄ per 100 or 1000 heads

	Number of heads	CH ₄ EF
Hens	100	1.061
Pullets (consumption), 112 days	100	0.285
Pullets (hatching), 119 days	100	0.303
Broilers:		
30 days	1 000	0.011
32 days	1 000	0.012
35 days	1 000	0.013
40 days	1 000	0.015
45 days	1 000	0.017
56 days	1 000	0.021
81 days (organic)	1 000	0.075
Other poultry		
Turkeys, male	100	0.014
Turkeys, hen	100	0.007
Ducks	100	0.003
Geese	100	0.005
Pheasant, chicken	1 000	0.003
Pheasant, hen	100	0.472
Ostrich, chicken	1	0.001
Ostrich, hen	1	0.660

Table 3D-6 Parameters for winter feeding plans.

		Feeding code*	% dm*	% Crude protein*	% Raw fat*	% Raw ashes*	% Carbo-hydrates	FU/kg dm*	kg dm/day**	MJ/day	GE _{FU}
		PDIR (2002)									
Heifers:	Straw	781	85.0	4.0	1.9	4.5	89.6	0.2	33.4	571.8	
	Maize silage	593	31.0	8.7	2.2	4.2	84.9	0.9	57.5	1 009.0	
	Toasted soya	155	87.5	49.1	3.2	7.4	40.3	1.4	8.1	161.7	
	Total	-	-	-	-	-	-	-	99.0	1 742.4	25.8
Suckling cows: Period 1 (2 mth)	Straw	781	85.0	4.0	1.9	4.5	89.6	0.2	1.6	119.1	
	Toasted soya	155	87.5	49.1	3.2	7.4	40.3	1.4	3.4	49.6	
	Barley	201	85.0	11.2	2.9	2.2	83.7	1.1	1.8	29.2	
Period 2 (4 mth)	Straw	781	85.0	4.0	1.9	4.5	89.6	0.2	3.2	238.2	
	Toasted soya	155	87.5	49.1	3.2	7.4	40.3	1.4	3.0	29.1	
	Barley	202	85.0	11.2	2.9	2.2	83.7	1.1	3.2	52.0	
	Total	-	-	-	-	-	-	-	15.2	517.1	34.0
Horses:	Straw	781	85.0	4.0	1.9	4.5	89.6	0.2	4.0	58.2	
	Hay	665	85.0	12.1	2.6	7.7	77.6	0.6	3.0	44.0	
	Oat	202	86.0	12.1	5.7	2.7	79.5	0.9	2.5	40.1	
	Supplemental		86.4	15.4	4.3	6.6	73.7	1.0	1.0	15.5	
	Total	-	-	-	-	-	-	-	-	157.7	29.8
Sheep and Goats:	Straw	781	85.0	4.0	1.9	4.5	89.6	0.2	1.0	14.6	
	Toasted soya	155	87.5	49.1	3.2	7.4	40.3	1.4	0.1	1.8	
	Barley	202	85.0	11.2	2.9	2.2	83.7	1.1	0.4	6.2	
	Grass pills (dried)	707	92.0	17.0	3.1	11.0	68.9	0.6	1.0	15.7	
	Total	-	-	-	-	-	-	-	-	38.2	30.0
Summer grazing											
Grazing	Clover grass, 2 weeks old	422	18.0	22.0	4.1	9.4	64.5	1.0	1.0	18.8	
	Total	-	-	-	-	-	-	-	1.0	18.8	18.8
Swine:	Full feeding										
	Sows	-	87.1	16.1	5.2	5.5	73.2	1.2	-	64.2	17.5
	Weaners	-	87.4	18.8	5.7	5.5	70.0	1.3	-	2.1	16.5
	Fattening pigs	-	86.9	17.0	4.7	5.1	73.3	1.2	-	9.6	17.3

Table 3D-7 Energy factors used for GE.

	MJ per kg dm
E _{Crude protein}	24.237
E _{Raw fat}	34.116
E _{Carbohydrates}	17.3

Table 3D-8 Feed intake 1990-2020, Dairy cattle; kg DM per cow per year, Others; FU per animal per year. <https://envs.au.dk/en/faglige-omraader/luftforurening-udledninger-og-effekter/udledning-af-luftforurening/greenhouse-gases/supporting-documentation> (most recently submitted values)

Table 3D-9 Grazing animals 1990 – 2020, number of days on grass per year. <https://envs.au.dk/en/faglige-omraader/luftforurening-udledninger-og-effekter/udledning-af-luftforurening/greenhouse-gases/supporting-documentation> (most recently submitted values)

Table 3D-10 Gross energy per kg DM for dairy cattle, 1990-2020, MJ per kg DM. <https://envs.au.dk/en/faglige-omraader/luftforurening-udledninger-og-effekter/udledning-af-luftforurening/greenhouse-gases/supporting-documentation> (most recently submitted values)

Table 3D-11 Average gross energy intake (GE) 1990 – 2020, MJ per head per day. <https://envs.au.dk/en/faglige-omraader/luftforurening-udledninger-og-effekter/udledning-af-luftforurening/greenhouse-gases/supporting-documentation> (most recently submitted values)

Table 3D-12 Implied Emission Factor of CH₄ from enteric fermentation, 1990 – 2020. <https://envs.au.dk/en/faglige-omraader/luftforurening-udledninger-og-effekter/udledning-af-luftforurening/greenhouse-gases/supporting-documentation> (most recently submitted values)

Table 3D-13 Emission of CH₄ from enteric fermentation, 1990 – 2020. <https://envs.au.dk/en/faglige-omraader/luftforurening-udledninger-og-effekter/udledning-af-luftforurening/greenhouse-gases/supporting-documentation> (most recently submitted values)

Table 3D-14 VS daily excretion 1990 – 2020, kg DM per head per day. <https://envs.au.dk/en/faglige-omraader/luftforurening-udledninger-og-effekter/udledning-af-luftforurening/greenhouse-gases/supporting-documentation> (most recently submitted values)

Table 3D-15 National manure management system and MCF vs. IPCC manure management system and MCF <https://envs.au.dk/en/faglige-omraader/luftforurening-udledninger-og-effekter/udledning-af-luftforurening/greenhouse-gases/supporting-documentation>

Table 3D-16 MCF for liquid manure, 1990 – 20 <https://envs.au.dk/en/faglige-omraader/luftforurening-udledninger-og-effekter/udledning-af-luftforurening/greenhouse-gases/supporting-documentation> (most recently submitted values)

Table 3D-17 Implied Emission Factor of CH₄ from manure management, 1990 – 2020, <https://envs.au.dk/en/faglige-omraader/luftforurening-udledninger-og-effekter/udledning-af-luftforurening/greenhouse-gases/supporting-documentation> (most recently submitted values)

Table 3D-18 Emission of CH₄ from manure management, 1990 – 2020.

<https://envs.au.dk/en/faglige-omraader/luffforurening-udledninger-og-effekter/udledning-af-luffforurening/greenhouse-gases/supporting-documentation> (most recently submitted values)

Table 3D-19 Area of agricultural land, 1990 – 2020, ha. <https://envs.au.dk/en/faglige-omraader/luffforurening-udledninger-og-effekter/udledning-af-luffforurening/greenhouse-gases/supporting-documentation> (most recently submitted values)

Table 3D-20 Above-ground residue dry matter AG_{DM(T)} 1990-2020, kg DM per ha.

<https://envs.au.dk/en/faglige-omraader/luffforurening-udledninger-og-effekter/udledning-af-luffforurening/greenhouse-gases/supporting-documentation> (most recently submitted values)

Nitrogen leaching and Run-off

Calculations of nitrogen lost by leaching from groundwater are based on two models described in Børgesen and Grant (2003) (in Danish). The model SKEP/DAISY is a dynamic model, N-LES is an empirical model and SKEP is an up scaling model. The SKEP/DAISY calculations were done for 10 scenarios (the years 1984, 1989 and 1995-2002) and the N-LES calculations were done for an 11-year period (1990-2000). Both calculations were up-scaled nationwide. The key parameters for the models were land use, nitrogen from synthetic fertilizer and manure, application practice for manure and NH₃ evaporation at application of manure (SKEP/DAISY only). The calculations were normalised to an average climate. A schematic overview of the models is seen below.

Basic DAISY calculations of N-leaching

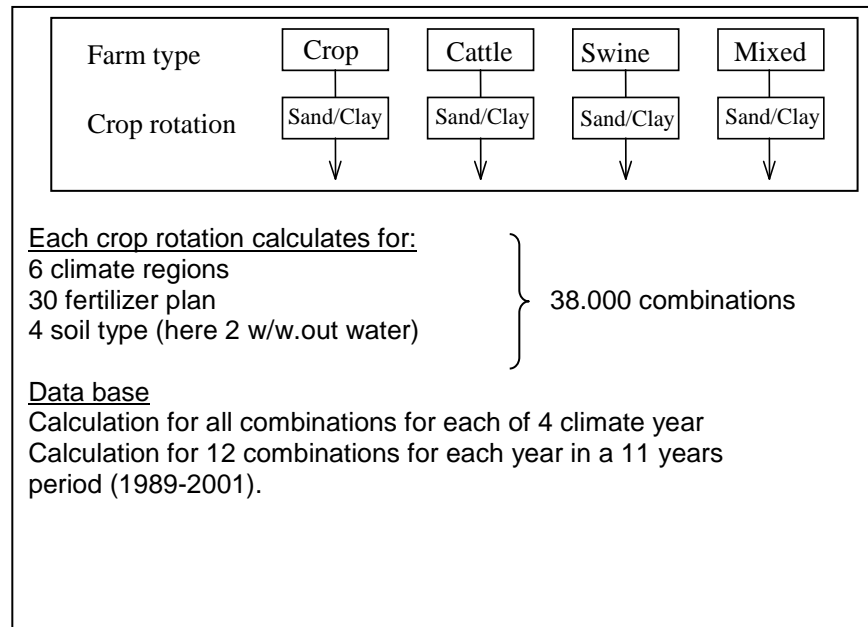

N-LES calculations

Model calculations for the crop rotations and fertilizer planes in SKEP plus appurtenant percolations from the DAISY calculations. Model calculations for each of the 11 years in the period 1989-2001, mean of the 11 years is up scaled nationwide by SKEP

Up-scaling by the SKEP model

In the up scaling of DAISY calculations a climate normalisation and yield correction is made

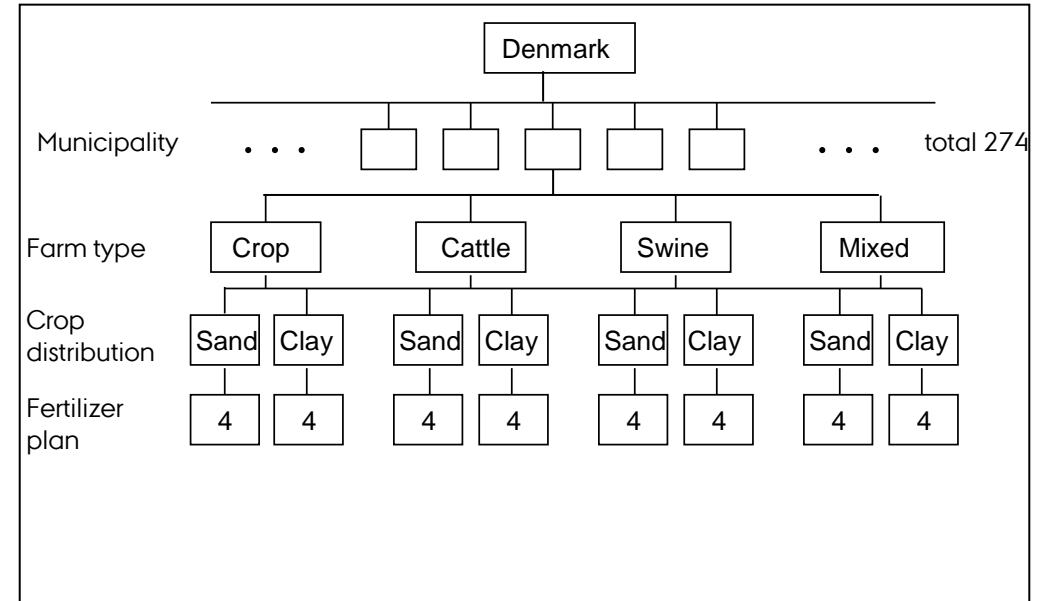

Figure 3D-1 Model calculation of nitrogen leaching from groundwater nationwide by SKEP/DAISY and N-LES.

Table 3D-21 QA/QC procedure, stage I – III.

Stage I: Check of input data	Variable	Reference
Livestock production	- number of animal - slaughter data	DSt
Normative figures	- N-excretion - use of straw - amount of manure - feed intake - milk yield	DCA
Housing types	- distribution	DAAS + DAFA
Grazing days		DAAS
Crops	- land use - crop yield - crop production	DSt
Synthetic fertiliser	- N-content - fertiliser types	DAFA
N-leaching	- amount of nitrogen leached	DCE
Atmospheric deposition	- all NH ₃ emission sources	DCE – NH ₃ inventory
Sewage sludge and industrial waste	- Amount of sludge applied to soils	EPA + DAFA
Stage II: Check of IDA data – overall	Emission source	Variable
Recalculation	- CO ₂ eqv. total emission - CH ₄ , N ₂ O, NMVOC - emission from field burning	- compared with latest submission
Time series	- CO ₂ eqv. total emission - CH ₄ , N ₂ O, NMVOC - emission from field burning	- trends - jumps and dips
Stage III: Check of IDA data – specific	Emission source	Variable
CH ₄	- enteric fermentation	- IEF (jumps and dips) - Y _m (dairy cattle + heifer) - GE
CH ₄	- manure management	- IEF (jumps and dips) - VS - biogas
N ₂ O	- manure management	- trends (jumps and dips) - IEF - biogas
N ₂ O	- synthetic fertiliser	- trends (jumps and dips) - IEF
N ₂ O	- animal waste applied to soil	- trends (jumps and dips) - IEF
N ₂ O	- N-fixing crops	- trends (jumps and dips) - IEF
N ₂ O	- crop residue	- trends (jumps and dips) - IEF
N ₂ O	- pasture, range and paddock	- trends (jumps and dips) - IEF
N ₂ O	- atmospheric deposition	- trends (jumps and dips) - IEF
N ₂ O	- N-leaching and run-off	- trends (jumps and dips) - IEF
N ₂ O	- sewage sludge + industrial waste	- trends (jumps and dips) - IEF
NMVOC	- crops	- trends (jumps and dips)

Chapter 3D-1 Biogas treatment of manure

Introduction

A significant and growing part of the Danish animal slurry is being used for production of biogas. The production uses anaerobic digestion of animal manure in combination with other biodegradable products, e.g. agricultural waste and slaughterhouse waste. Biogas treatment is important to include in the inventory, because the anaerobic digested slurry produces lower CH₄ emission from storage and from applied slurry on cultivated soils.

CH₄ emission from manure management depends, among other variables, on the CH₄ conversion factor (MCF), which depends on the actual temperature and storage conditions. The 2006 IPCC Guidelines Tier 2 approach recommends a MCF at 10 % for covered and a MCF at 17 % for uncovered swine and cattle slurry for cool climate (average annual temperature ≤10 °C). Based on study activities in 2015-2016 a national MCF has been estimated for raw untreated slurry and for anaerobic digested slurry, from cattle and swine slurry respectively. Focus has been on cattle and swine slurry, which cover >95 % of the total CH₄ emission from manure management.

The result of the national MCF estimated will first be presented. Following is an overview of the biogas production in Denmark and the estimation of the amount of treated slurry. Finally a more detailed description and documentation of the estimation of the national MCF is provided.

National estimated MCF for cattle- and swine slurry

The national estimates of MCF are based on temperature dependent degradation functions, which take into account the different temperature conditions inside the barns and during outdoor storage. The storage time and the related CH₄ emission inside the barns, outdoor storage and storage of anaerobic digested biomass is also taken into account. The approach use temperature dependent functions adapted to Danish conditions.

The national estimated MCF for untreated swine- and cattle slurry is higher than the 2006 IPCC Guidelines default for cool climate (≤10 °C) The national study shows a fast turnover of VS especially for the swine slurry inside the barns caused by the relatively high temperatures (Møller, 2013), which leading to a high emission of methane per kg of VS.

Table 3D-22 shows the trend 1990 - 2020 for the national estimated MCF for cattle and swine slurry both digested and not digested. The national estimated MCF for not digested slurry for cattle is changing slightly over time, from 12.00 in 1990 to 12.28 in 2020. The MCF for not digested slurry for swine is reduced from 15.25 in 1990 to 13.31 in 2020. The changes in MCF over time is mainly caused by change in the distribution of housing system, which influences the average HRT (Hydraulic Retention Time).

Table 3D-22 Estimated methane conversion factor (MCF) for digested and not digested cattle and swine slurry from 1990 to 2020, %.

	1990	1995	2000	2005	2010	2015	2018	2019	2020
Cattle									
MCF for digested cattle slurry	6.46	6.43	7.40	7.40	7.66	8.11	7.81	7.78	7.74
MCF for not digested cattle slurry	12.00	11.89	12.70	12.55	12.56	12.59	12.40	12.32	12.28
Swine									
MCF for digested swine slurry	12,13	11,98	11,68	10,92	11,01	10,99	10,33	10,35	10,34
MCF for not digested swine slurry	15.25	15.11	14.87	14.03	13.93	13.67	13.37	13.33	13.31

Estimation of slurry treated in biogas plants in Denmark

In Denmark, the biogas plants are divided in five facility types; wastewater, industrial, landfills, large-scale plants (centralised multi farms) and farm-level plants. Large-scale biogas plants are larger facilities, where slurry is received from several farms and farm-level plants are characterised by receiving manure from one or a few farms. For 2020, the Energy Statistics estimated the total energy production based on biogas to 21 379 TJ (DEA, 2020a), and out of this, the manure based biogas plants account for 90 % produced at approximately 30 large-scale plants and 60 farm-level plants. The Energy Statistic provides data annually and thus data from all years 1990-2020 is available.

Table 3D-23 Biogas production, 2020 (DEA, 2021a).

Facility type	Biogas production, TJ	%
Wastewater treatment	1 307	6
Industrial	844	4
Large-scale and farm-scale*	19 228	90
Total	21 379	100

*Include Landfill, which only accounts for approximately 135 TJ (less than 1 % of total biogas production).

The livestock production mainly takes place in the western parts of Denmark in Jutland and consequently the majority of manure based biogas plants are located here.

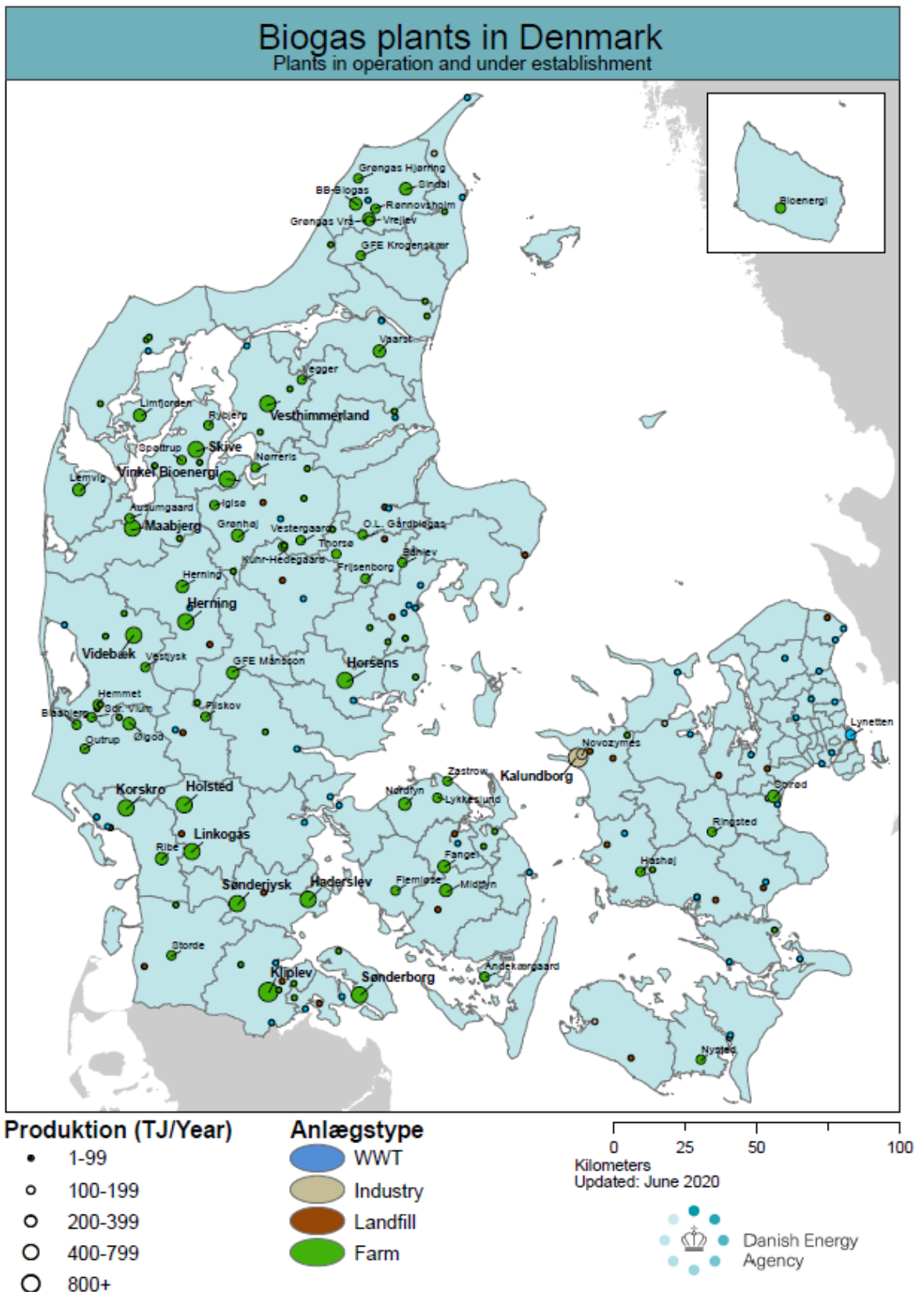

Figure 3D-2 Biogas producers in Denmark, 2019 (DEA, 2020). WWT – waste water treatment.

For year 2015-2020, data for the actual amount and different types of biomass delivered to the biogas plants is available. Data is collected by the Danish Energy Agency (DEA, 2021b), based on reporting from each biogas plant and covers data from all the biggest biogas plants. In the following, these data are

referenced as the BIB-register; Biomass Input to Biogas production. The BIB register does not fully cover all biogas plants, but the most important biogas producers, and thus it covers 80-90 % of the total biogas production.

Data regarding the amount of slurry delivered to biogas plants is available for the years 2001, 2003, 2015-2020. Data for year 2001 and 2003 is based on a single investigation provided by the DEA – the Danish Energy Agency, while the data for year 2015-2020 is based on the BIB – register. For the intervening years, 1990-2000, 2002 and 2004-2014, the data for amount of slurry delivered to the biogas production is based on an interpolation, by using the relation between the amount of slurry delivered and the total energy production produced at the biogas plants. The total energy production from biogas plants for all years is based on the Energy Statistics (DEA, 2021a).

In 1990, the biogas production at the large-scale, farm-level and industrial biogas plants is 266 TJ, which correspond to slurry input of 220 kt, increasing to 19 937 TJ and 8 303 kt slurry in 2020.

In 2020, around 14 % of total amount of slurry is delivered to biogas production, 17 % of the total amount of cattle slurry and 12 % for swine slurry.

Table 3D-24 Biogas production, 1990-2020.

	1990	1995	2000	2005	2010	2015	2018	2019	2020
Biogas production, TJ¹									
Total	752	1 758	2 912	3 830	4 337	6 285	13 333	16 544	21 379
Biogas plants*	266	746	1 442	2 375	3 184	5 199	12 244	15 278	19 937
Slurry delivered to biogas plants, kt²									
Cattle, swine and mixed	220	617	1 192	1 838	2 115	2 884	5 741	7 073	8 303
Percent of total produced slurry	1	2	3	4	4	5	10	13	14

* Large-scale, farm-level and industrial.

¹DEA, 2021a.

²DEA, 2021b.

The anaerobic digestion process is complicated and sensitive to several factors, such as different biomass types and different combination of biomass input, nutrients concentration, species and concentration of bacteria, operational conditions for each biogas plants, etc. Uses of current data from the BIB register will to some extent take these variations from biogas plant to biogas plant into account, because the data is based on existing production.

Calculation method for the national MCF

MCF is estimated by using the Tier 2 equation for estimating CH₄ emission factor from manure management from IPCC 2006:

$$MCF_{not\ digested} = \left(\frac{E_{barns} + E_{storage, not\ digested}}{VS_{barns}} \right) / (0.67 \cdot B_0) \quad (\text{Eq. 3D-1})$$

Where:

MCF_{not digested} = methane conversion factor for not digested slurry, %

E_{barns} = emission of CH₄ from barns, kg CH₄, see Equation 3D-3

$E_{\text{storage, not digested}}$	= emission of CH ₄ from storage of not digested slurry, kg CH ₄ , see Equation 3D-4
VS_{barns}	= amount of volatile solids, kg VS, based on VS excreted, see Table 3D-26
B_0	= maximum methane producing capacity, m ³ CH ₄ per VS
0.67	= conversion factor, CH ₄ per m ³ CH ₄

$$\text{MCF}_{\text{digested}} = \left(\frac{E_{\text{barns}} + E_{\text{storage, digested}}}{VS_{\text{barns}}} \right) / (0.67 \cdot B_0) \quad (\text{Eq. 3D-2})$$

Where:

$\text{MCF}_{\text{digested}}$	= methane conversion factor for digested slurry, %
E_{barns}	= emission of CH ₄ from barns, kg CH ₄ , see Equation 3D-3
$E_{\text{storage, digested}}$	= emission of CH ₄ from storage of not digested slurry, kg CH ₄ , see Equation 3D-4
VS_{barns}	= amount of volatile solids, kg VS, based on VS excreted, see Table 3D-26
B_0	= maximum methane producing capacity, m ³ CH ₄ per VS
0.67	= conversion factor, CH ₄ per m ³ CH ₄

Estimation of methane emission from raw cattle and swine slurry and anaerobic digested animal manure

The CH₄ emission from liquid cattle and swine manure is based on CH₄ emission from barns, from outdoor stored raw cattle and swine slurry, from anaerobic digesters and from anaerobically digested biomass/primarily animal manure.

Emission of CH₄ from barns

$$E_{\text{barns}} = VS_{\text{barns}} \cdot \text{EF}_{\text{barns}} \cdot \text{HRT} / 365 \quad (\text{Eq. 3D-3})$$

Where:

E_{barns}	= emission of CH ₄ from barns, kg CH ₄
VS_{barns}	= amount of volatile solids, kg VS, based on VS excreted, see Table 3D-26
EF_{barns}	= emission factor for CH ₄ , based on measurements see Table 3D-25
HRT	= Hydraulic Retention Time, days, see Table 3D-26

Emission of CH₄ from storage of not digested slurry

CH₄ emission from storage of slurry is estimated as VS multiplied by EF where VS is divided in VS degradable (VSd) and VS non-degradable¹ (VSnd).

$$E_{\text{storage, not digested}} = VS_{\text{d, storage, not digested}} \cdot \text{EF}_{\text{d, storage, not digested}} + VS_{\text{nd, storage, not digested}} \cdot \text{EF}_{\text{nd, storage, not digested}} \quad (\text{Eq. 3D-4})$$

Where:

$E_{\text{storage, not digested}}$	= emission of CH ₄ from storage of not digested slurry, kg CH ₄
$VS_{\text{d, storage, not digested}}$	= amount of degradable volatile solids in the slurry not digested, see Table 3D-26
$\text{EF}_{\text{d, storage, not digested}}$	= emission factor for CH ₄ for degradable VS, see Table 3D-25

¹ Non-degradable could also be referred to as low-degradable because a small decomposition is possible.

$VS_{nd,storage, not\ digested}$ = amount of non-degradable volatile solids in the slurry not digested, see Table 3D-26

$EF_{nd,storage, not\ digested}$ = emission factor for CH₄ for degradable VS, see Table 3D-25

Emission of CH₄ from storage of digested slurry

$$E_{Storage,digested} = VS_{Storage,digested} \cdot EF_{Storage,digested} \quad (\text{Eq. 3D-5})$$

Where:

$E_{Storage, digested}$ = emission of CH₄ from storage of digested slurry, kg CH₄

$VS_{Storage, digested}$ = amount of volatile solids in the slurry digested, see Table 3D-26

$EF_{Storage, digested}$ = emission factor for CH₄ for VS, see Table 3D-25

Table 3D-25 Estimated emission factors.

Cattle	
EF_{barns} , g CH ₄ per kg VS per year	179.79
$EF_{d,storage, not\ digested}$, g CH ₄ per kg VSd per year	28.08
$EF_{nd,storage, not\ digested}$, g CH ₄ per kg VSnd per year	0.51
$EF_{Storage, digested}$, g CH ₄ per kg VS per year	1.76
Swine	
EF_{barns} , g CH ₄ per kg VS per year	563.22
$EF_{d,storage, not\ digested}$, g CH ₄ per kg VSd per year	29.58
$EF_{nd,storage, not\ digested}$, g CH ₄ per kg VSnd per year	0.56
$EF_{Storage, digested}$, g CH ₄ per kg VS per year	1.76

Table 3D-26a-c shows the estimated CH₄ emission from liquid cattle and swine slurry for the years 1990-2020. Table 3D-26a-c shows the total amount of liquid VS excreted by cattle and swine, the average HRT, the estimated g CH₄ per kg VS and the total emission of CH₄ from that category.

For cattle slurry, the total emission in barns in 1990 has been estimated to 10.32 kt CH₄ increasing to 13.33 kt CH₄ in 2020. The increase in this emission is due to change in housing systems where the slurry is kept in the housings longer and more slurry. In addition to this, an emission from outdoor storage estimated to 10.30 kt CH₄ in 1990 and decreased to 9.99 kt CH₄ in 2020. To this comes a small amount from digested manure (Table 3D-26c).

For swine slurry, the total emission inside the barns in 1990 has been estimated to 18.69 kt CH₄ in 1990 increasing to 26.64 kt CH₄ in 2020, due to a growing swine production until 2011. To this comes an emission from outdoor storage. This has been estimated to 6.52 kt CH₄ in 1990 and an increase to 10.72 kt CH₄ in 2020. The increase in this emission is due to increase in the share of degradable volatile solids in the slurry. In addition, a small amount is realised from the digested manure (Table 3D-26c).

Table 3D-26a Emission estimates for cattle slurry inside the barns and not digested stored liquid manure.

Cattle	1990	1995	2000	2005	2010	2015	2018	2019	2020
<u>Barns</u>									
Slurry, tonnes VS per year	1 140 939	1 044 346	1 014 726	1 160 046	1 204 501	1 281 868	1 342 416	1 329 862	1 330 589
EF, g CH ₄ per kg VS per year	179.79	179.79	179.79	179.79	179.79	179.79	179.79	179.79	179.79
Average HRT, days	18.36	18.48	21.47	21.25	21.17	21.21	20.70	20.44	20.33
EF, g CH ₄ per kg VS per year	9.04	9.10	10.58	10.47	10.43	10.44	10.20	10.07	10.02
Emission, kt CH ₄ per year	10.32	9.51	10.73	12.14	12.56	13.39	13.69	13.39	13.33
<u>Storage, not digested</u>									
Slurry, not digested, tonnes VSd ab barn	353 217	317 484	299 454	339 155	352 957	373 431	367 803	352 149	342 575
Slurry, not digested, tonnes VSnd ab barn	756 868	680 564	647 771	733 148	762 807	807 135	793 752	759 370	738 482
EF, g CH ₄ per kg VSd per year	28.08	28.08	28.08	28.08	28.08	28.08	28.08	28.08	28.08
EF, g CH ₄ per kg VSnd per year	0.51	0.51	0.51	0.51	0.51	0.51	0.51	0.51	0.51
Emission, kt CH ₄ per year	10.30	9.26	8.74	9.89	10.30	10.89	10.73	10.27	9.99

Table 3D-26b Emission estimates for swine slurry inside the barns and not digested stored liquid manure.

Swine	1990	1995	2000	2005	2010	2015	2018	2019	2020
<u>Barns</u>									
Slurry, tonnes VS per year	548 932	718 704	816 232	944 522	950 766	930 091	951 393	909 293	966 929
EF, g CH ₄ per kg VS per year	563.22	563.22	563.22	563.22	563.22	563.22	563.22	563.22	563.22
Average HRT, days	22.06	21.77	21.23	19.41	19.19	18.62	17.97	17.90	17.85
EF, g CH ₄ per kg VS per year	34.04	33.59	32.76	29.95	29.62	28.74	27.72	27.62	27.55
Emission, kt CH ₄ per year	18.69	24.14	26.74	28.29	28.16	26.73	26.38	25.11	26.64
<u>Storage, not digested</u>									
Slurry, not digested, tonnes VSd ab barn	215 207	281 082	318 577	375 945	377 809	367 629	361 792	337 868	354 959
Slurry, not digested, tonnes VSnd ab barn	266 891	347 231	390 775	450 443	451 444	436 121	425 663	397 163	417 019
EF, g CH ₄ per kg VSd per year	29.58	29.58	29.58	29.58	29.58	29.58	29.58	29.58	29.58
EF, g CH ₄ per kg VSnd per year	0.56	0.56	0.56	0.56	0.56	0.56	0.56	0.56	0.56
Emission, kt CH ₄ per year	6.52	8.51	9.64	11.37	11.43	11.12	10.94	10.22	10.73

Table 3D-26c Emission estimates for digested biomass.

Digested biomass	1990	1995	2000	2005	2010	2015	2018	2019	2020
VSd, tonnes	8 551	23 942	46 279	77 773	109 374	186 923	328 671	422 714	495 469
EF, g CH ₄ per kg VS per year	1.76	1.76	1.76	1.76	1.76	1.76	1.76	1.76	1.76
Emission, kt CH ₄ per year	0.02	0.04	0.08	0.14	0.19	0.33	0.58	0.74	0.87

Documentation for estimation of the national MCF

CH₄ formation in manure is mainly formed by microorganisms that produce methane as a metabolic by-product in anoxic conditions. They are classified as archaea, a domain distinct from bacteria. The metabolism is temperature dependent, and actual temperatures are therefore the main driver for the methanogenesis.

The overall methodology for estimating the CH₄ emission from liquid animal manure and anaerobically digested biomass is based on the available amount of volatile substance (VS) in the biomass and the temperature dependent CH₄ formation functions (Van't-Hoof/ Arrhenius equation) (Sommer et al., 2004). The model by Sommer et al. (2004) uses a 2-pooled concept for estimating the CH₄ emission from degradable VS (VS_d) and from non-degradable² VS (VS_{nd}). The emission from VS_{nd} has been set to 1 % of VS (Sommer et al., 2001, 2004). During storage inside the barns, in outdoor storages and in the anaerobic digesters VS is degraded. To take into account a "decreasing" emission due to depletion of the VS in the manure in up to 8-9 months a degradation model has been developed.

For the purpose of documenting the emission estimate in the inventories the following tasks have been performed:

- a thorough literature search
- estimation of temperature functions for animal manure stored
 - inside the barns for swine and cattle barns
 - outdoor storage for untreated liquid manure
 - anaerobically digested manure
- estimation of storage time, HRT (Hydraulic Retention Time) in the barns (Kai et al., 2015)
- temperature dependent CH₄ formation from 20 samples of different types of liquid swine manure and 11 samples of different type of liquid dairy cattle manure (Petersen et al., 2016)
- developing a model to estimate the storage time in outdoor liquid manure stores
- compilation of data from BIB. The BIB include information on suppliers, amount and types of manure and other biomass used in the Danish anaerobic digesters
- developing an emission model based on time steps of 10 days.

Parameters for Arrhenius function

For the CH₄ calculation, a model based on VS quantity and degradability and temperature was used (Sommer et al., 2004). The parameters for Arrhenius function is based on Petersen et al. (2016), Elsgaard et al. (2016) and Maldaner et al. (2018). Equation 11.18 shows the calculation of CH₄ emission form slurry $F(T)$, VS_d and VS_{nd} are the proportions of degradable and "non-degradable" VS. The $\ln A$ is the pre-exponential factor (\approx methane production potential) and E_a the activation energy of methanogenesis, while R is the universal gas constant and T is the absolute temperature.

$$F(T) = \left(VS_d * b_1 * \exp\left(\ln A - E_a * \left(\frac{1}{RT}\right)\right) + VS_{nd} * b_2 * \exp\left(\ln A - E_a * \left(\frac{1}{RT}\right)\right) \right) \cdot 24 \quad (\text{Eq. 11.18})$$

Where:

² Non-degradable could also be refed to as low-degradable because a small decomposition is possible.

$F(T)$	= the methane production rate, g CH ₄ per day
VS_d	= the proportions of degradable volatile solids, kg
VS_{nd}	= the proportions of non-degradable volatile solids, kg
b_1 and b_2	= scaling factors, 1 for VS_d and 0.01 for VS_{nd} (dimension-less)
$\ln A$	= the pre-exponential factor (\approx methane production potential), g CH ₄ per kg VS _d per h or g CH ₄ per kg VS per h (digestate)
E_a	= the activation energy of methanogenesis, J per mol
R	= the gas constant, 8.314 J per mol per K
T	= temperature, K
24	= conversion from hour to day

Ea: An activation energy, E_a , of 81 kJ per mol was recently proposed by Elsgaard et al. (2016) which represented the temperature response of a cattle slurry, a swine slurry, fresh digestate and stored digestate (no significant differences).

lnA: The parameter $\ln A$ reflects a potential for CH₄ production that is influenced by the chemical and biological characteristics of the slurry, which in Petersen et al. (2016) is derived for 20 samples of swine slurry and 11 samples cattle slurry. In average the observed $\ln A$ was 31.3 and 31.2 g CH₄ kg⁻¹ VS h⁻¹ for pig and cattle slurry, respectively.

VS – volatile solid: The amount of excreted dry matter is taken from the Danish Normative System for animal manure (data included in IDA). The share of VS of dry matter is set as a default to 80 % as used in the agricultural inventories.

VS_d and VS_{nd}: In the model for estimating the CH₄ emission a 2-pooled model is used, dividing the VS in VS_d and VS_{nd} (Tong et al., 1990, Sommer et al., 2004). The share of VS_d and VS_{nd} has for the purpose of the inventories been estimated by Petersen et al. (2016) for swine (sow, weaners and fattening pigs) and cattle slurry (mainly dairy cattle slurry). The manure samples were taken in barns in full production and can thus be seen as normal farming practise. Petersen et al. (2016) estimated the average age of the swine slurry to 13-15 days and the cattle slurry to around 20-30 days. The slurry samples can therefore be seen as quite fresh manure with only little degradation.

Petersen et al. (2016) sampled 20 swine slurry samples and 11 dairy cattle slurry samples and estimated the VS_d . For swine manure they found an average VS_d of 51 % (95 % Confidence Interval: 44 – 57 %) and for slurry for dairy cattle a VS_d of 33 % (95 % Confidence Interval: 29 – 37 %).

Møller and Moset (2015) has measured dry matter and VS in digested manure from eight biogas plants. They found an average dry matter in the digested manure of 4.88 % were VS of dry matter in average were 3.32 %. Møller (2016) has measured the B₀-value of the digestate from the continuous biogas plants to 13.8 m³ CH₄ per kg VS indicating that the major part of the digestate is non-degradable. Based on the model, which take storage time and temperature into account, the emission factor for VS_{digested} were estimated to 1.76 g CH₄ per kg VS per year

In Table 3D-27 is shown the used parameters.

Table 3D-27 CH₄ emission estimate parameters. Petersen et al. (2016) combined with Elsgaard et al. (2016) and Maldaner et al. (2018).

	Ea, kJ per mol	Ln(A), g CH ₄ per kg VS per hour	VSd, %	VSnd, %
Liquid cattle manure	81	31.2	33	67
Liquid swine manure	81	31.3	51	49
Digestate	81	27.9	100 ^a	0

^aFor digestate, the model parameter is set to 100 mimicking that all VS is degradable.

Degradation function

Based on literature data and unpublished research data it was estimated that the C loss from manure stores constitutes roughly of 20 % CH₄-C and 80 % CO₂-C (Dinuccion et al., 2008). In the emission estimate a conservative figure of 25 % is used. Beside this Patni and Jui (1987) found 10-25 % losses of dry matter during storage of dairy cattle slurry supporting that a high share of loss of VS is taken place as CO₂ as this is not lost as CH₄. For effluent from digested animal manure, Wang et al. (2016) found very low CH₄/CO₂ ratios at around 3-4 % (unpublished data received from Yue Wang). For the digestate, an estimate for CH₄-C/CO₂-C fraction of 10 % is used (Dong, 2013, Pers. Comm.).

The CH₄/degradation model was built in an excel spreadsheet with a time step of 10 days.

Danish animal housing systems and Hydraulic Retention Time (HRT)

The most common housing systems for swine in Denmark are partly plug-systems with slatted floors and a depth of the slurry channels of 40-60 cm. The storage capacity inside the barns in these systems is around 40 days. After 40 days the farmers pull the plugs and the slurry under the slats are flushed to the outdoor storage tanks. During the production cycle of weaners and fattening pigs it is normally only needed to flush once during the production, and once after the pigs have been moved and the barn is washed and cleaned. In these systems the average storage time is therefore app. 40 days/2 = 20 days. The average storage time is named the Hydraulic Retention Time (HRT).

For the purpose of the Danish inventories, Kai et al. (2015) have investigated/measured the storage capacity in swine and cattle barns and estimated the HRT for all barn types mentioned in the Danish Normative System for animal manure.

Animal housing systems change over time. To take into account changes in the HRT inside the barns over time since 1990, the shares of the different barn types have been multiplied with the HRT for each barn type and summed for swine and cattle slurry to get the average HRT for swine and cattle slurry (Table 3D.29). The HRT for liquid cattle manure has increased since 1990. This is mainly because in the 1990's there was a high share of tied-up dairy cattle with liquid handling and frequent removal of the slurry. These were later replaced by cubicles combined with slats. In recent years cubicles with scrapers are becoming more common so a decrease in the HRT for cattle is expected in the future. The most common housing system for swine has until recently been fully slatted floors. A ban on fully slatted floors forced the farmers to build partly slatted floors/drainage floors. This has reduced the storage capacity below the slats and thus reduced the average HRT for swine slurry.

Table 3D-28 Average Hydraulic Retention Time (HRT) in cattle and swine barns from 1990 to 2020.

	1990	1995	2000	2005	2010	2015	2018	2019	2020
Cattle	18.36	18.48	21.47	21.25	21.17	21.21	20.70	20.44	20.33
Swine	22.06	21.77	21.23	19.41	19.19	18.62	17.97	17.90	17.85

In the emission estimate, it is assumed that all manure regardless of whether it is used for anaerobic digestion or not is having the same HRT. The data collected by Kai et al. (2015) do not prove that farms delivering manure to anaerobic digestion are emptying their slurry channels more frequently than farmers who are not.

Temperatures

Based on average air temperature for the period 2001-2010, measured temperatures and literature data temperature functions have been developed.

Insulated swine barns

Only few measured slurry temperatures inside the barns can be found in the literature. Some measurements have been made by SEGES (Holm, 2015). Besides this, Petersen et al. (2016) have measured slurry temperatures in 27 different swine barns in November and December 2014 in connection with the CH₄ emission parameterisation. Holm (2015, Pers. Comm.) has made 48 measurements in barns with fattening pigs at different times of the year and found an average slurry temperature of 18.6 °C (16.0-21.8 °C) with a standard deviation of 1.29. The highest temperatures were measured in summer. When the average outdoor temperature was 16-17 °C the slurry temperature tended to be around 19 °C. In winter when the average outdoor temperature was around 2-5 °C the slurry temperature was 17-18 °C (Figure 3D-5). The dots represent different combinations of slurry height and temperatures. Petersen et al. (2016) found an average temperature of 18.7 °C in their measurements in November and December. In the inventories are used the average data of 18.6 °C from SEGES throughout as the data are not sufficient qualified to distinguish between winter and summer. Figure 3D-3 shows the measured data by SEGES.

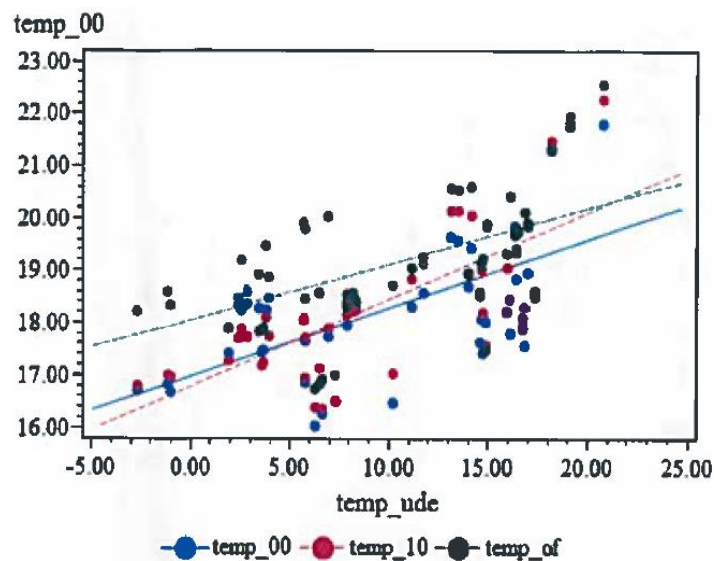

Figure 3D-3 Measured slurry temperature in fattening pig slurry channel in different times during the production cycle. The different colours indicate different slurry heights in the slurry channel (Holm, 2015).

Open cattle barns

Most cattle barns in Denmark are naturally ventilated. Inside the barns the air temperature is generally 5-6 °C higher than the outdoor temperature. The manure temperature inside the slurry channels do not follow the air temperature closely (Andersen and Grønkjær, 2020). In 2017 and 2018, temperature measurements were carried out in one cattle barn in the Southern Denmark and one in the Northern Denmark with logging 2-5 times per day. As Denmark is quite small, these data were combined and converted to a sine-wave representing whole Denmark (Figure 3D-4).

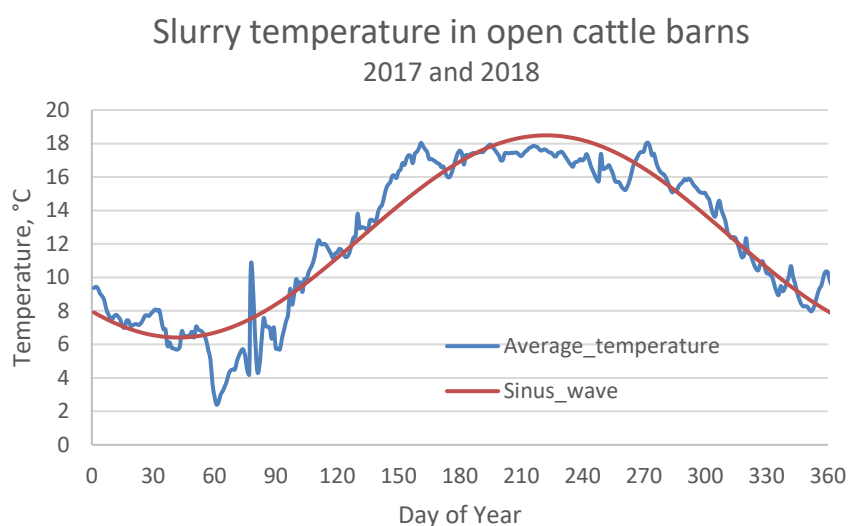

Figure 3D-4 Average daily measured slurry temperature in two cattle barns in 2017 and 2018 (Andersen and Grønkjær, 2020).

Table 3D-29 shows given the parameters for the Sine-function, which estimates the daily average air temperatures.

Table 3D-29 Parameters for the Sine-function ($y=a+ b \sin (2\pi x/d+c)$) for air temperature. $R^2 = 0.92$

Parameter	Value	Std Error	t-value	95% confidence limits	
a	12.45	0.087	142.64	12.28	12.62
b	6.04	0.098	61.55	5.84	6.23
c	3.97	0.046	86.73	3.89	4.07
d	360.08	4.209	85.55	351.80	368.35

Outdoor storage temperatures

The temperature in outdoor slurry tanks is expected to follow the outdoor temperature to a great extent. As with indoor storage only few data can be found in the literature. The temperature is a function of the loading with slurry, the actual amount stored and the solar radiation. If data from other climatic conditions is used they therefore have to be converted to Danish conditions. E.g. Park et al. (2006) found a linear relation between air temperature and slurry temperature in Canada with the following model parameters: $\text{Slurry_temperature} = \text{Air_temperature} * 0.879 + 4.24$ (Figure 3D-5). However, the locations used for this study is far more southern than Denmark and are thus not suited for Danish conditions, especially not during summer where a higher solar radiation is occurring. Hansen et al. (2006) measured the slurry temperatures in slurry tanks throughout a year on three farms receiving digestate from anaerobic digesters. They found also a linear relation similar to Park et al. (2006) with the parameters $\text{Slurry_temperature} = \text{Air_temperature} * 0.75 + 6.23$ (Figure 3D-5). The measurements by Hansen et al. (2006) cannot be seen as representative for raw liquid manure as the digestate as a starting

point is having a higher temperature than raw slurry due to the exothermic process in the anaerobic digesters. The model by Hansen et al. (2006) is used for anaerobically digested manure as this is likely a normal temperature profile for digestate returned to the farms for continued storage.

For raw slurry, a linear model has been constructed with data from Husted (1994) and Rodhe et al. (2009, 2012, 2015) with the following parameters $\text{Slurry_temperature} = \text{Air_temperature} * 0.5011 + 5.1886$ ($r^2 = 0.75$).

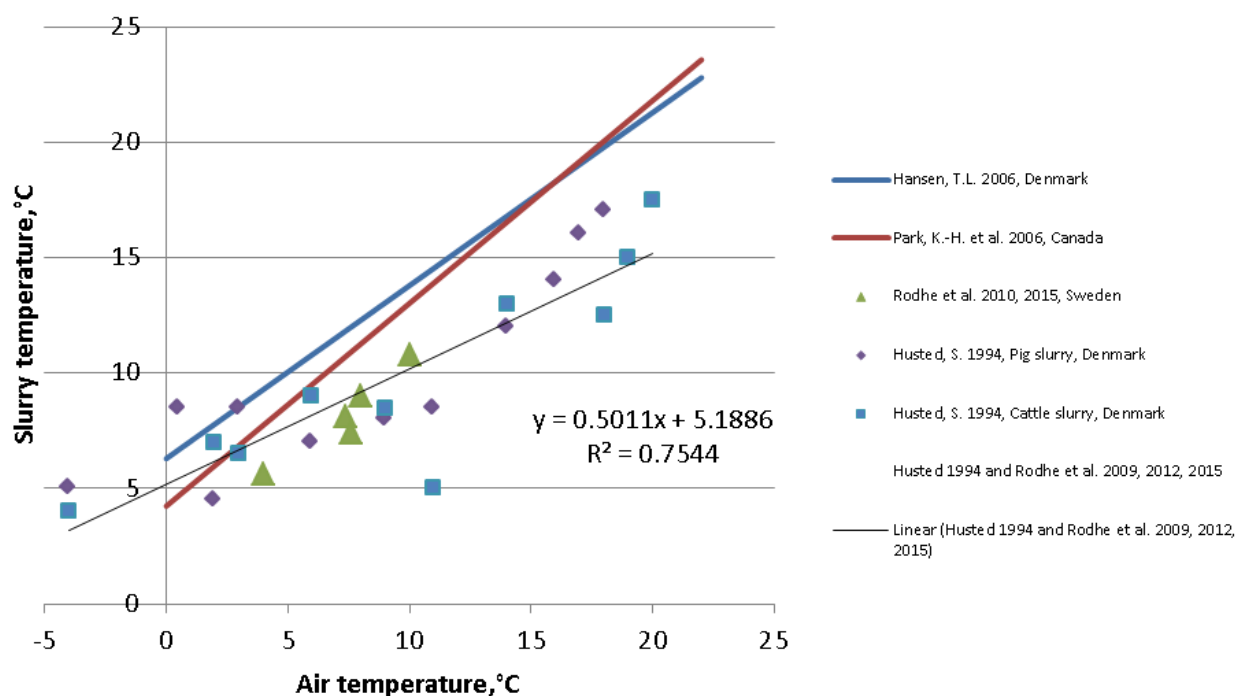

Figure 3D-5 Measured and modelled slurry temperatures in outdoor storage tanks.

Manure storage and application to fields

The Ministry of Environment and Food of Denmark regulate the storage time and the secondary field application of raw biomass and digested biomass. The general rule is that manure is only allowed to be applied to crops, which have a nitrogen norm and is harvested the same calendar year. Only crops with an official nitrogen norm are allowed to be fertilised.

It means that autumn application is not allowed as these crops are not harvested within the calendar year. The storage manure capacity is therefore 8-10 months including eventually storage capacity inside the barns.

Field application of manure is not allowed before February 1st and not on frozen or snow covered areas. Because of difficulties for driving in the fields the optimum application time is March and April, plus some application to grass cuttings during summer. In cooperation with the Danish Agricultural Advisory Centre (SEGES), a general storage profile for animal manure storages has been developed, Figure 3D-6. The figure shows that the maximum storage is in February and the minimum in end April. Slurry is generally stored in four meter deep concrete tanks where two meters are above ground and two meters below ground. As it is not possible to empty the tanks completely (crust cover) it is assumed that 10 % of the annual production is the minimum amount stored by end of April.

No reduction in the CH₄ emission due to microbial degradation in the crust cover (IPCC 2006) is implemented in the emission estimate so far.

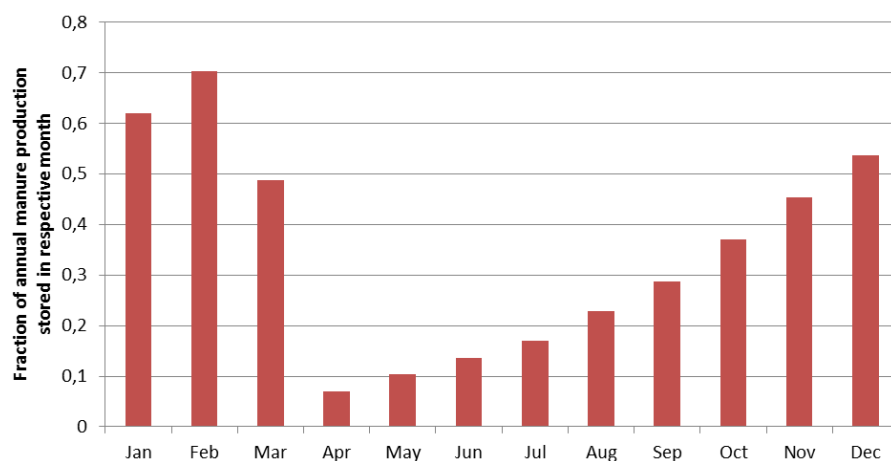

Figure 3D-6 The fraction of animal manure stored during different month of the year. The fraction is the share of the total annual manure production corrected for grazing. Small amounts are applied to grass during summer giving a lower increase in the summer months than in the winter period.

The model

The model estimates methane emission for slurry from cattle and swine. Estimations of CH_4 , VSd and VSnd is based on measurements (Petersen et al., 2016). The measurements are not made on the exact time for excretion of the manure and the CH_4 emission is therefore calculated as a constant emission per day, even though some degrading of VS in the barn will take place. The CH_4 emission in barns for swine at 18.6 °C is estimated to 563.22 g CH_4 per kg VS per year, corresponding to 1.54 g CH_4 per kg VS per day. VS from barns are not divided in VSd and VSnd because the measured emission relate to the total amount of VS. The total CH_4 emission from barns is calculated as excreted VS multiplied by 1.54 g CH_4 per kg VS per day and average storage time (HRT) in the barn.

For cattle barns, the temperature varies through the year. The emission factor of 179.79 g CH_4 per kg VS per year given in Table 3D-25 is an average for a year. For cattle total CH_4 emission from barns is also calculated as VS multiplied with average store time (HRT). It is assumed that excretion of VS in barns is constant. The period in which the cattle is on grass gives less manure in the barns, but this is not taken in to account. It is assumed that the effect of grazing is very small because the majority of dairy cattle in Denmark spend most of the time in the barns.

Methane emission from outdoor storage of not digested slurry is estimated in a matrix, where slurry is supplied and taken away with a time step of 10 days. The matrix sums the total methane emission until the decomposition of VS is almost null (around two years). The amount of VS supplied the storage is the total VS excretion from the animals and the straw used for bedding, subtracted VS-loss from barns. Removal of VSd and VSnd from storage is estimated for every time step and a new methane emission is calculated. For cattle slurry the estimation gives an emission of 0.51 g CH_4 per kg and for swine slurry the estimation gives 0.56 g CH_4 per kg VS (Table 3D-25).

For estimation of methane emission from outdoor storage of digested slurry, the amount of digested slurry delivered to the biogas plants based on the BIB register is used. Same model as used for not digested slurry is used for digested slurry, though with a higher temperature in the storage after biogas treatment. The stored digested slurry has a high content of VSnd and the emission of methane is therefore low. Due to the low activity of the decomposition,

a lower CH₄:CO₂-ratio (of 0.1) is assumed for digested slurry compared to not digested slurry (Dong, 2013, Pers. Comm.).

References

Andersen, M and Grønkjær, A., 2020: Personal communication. Unpublished data on slurry temperatures in two cattle barns measured in 2017 and 2018. Danish Technological Institute, DTI.

DEA (Danish Energy Agency), 2021a: The Danish energy statistics, Available at: <https://ens.dk/en/our-services/statistics-data-key-figures-and-energy-maps/annual-and-monthly-statistics> (Feb. 2022).

DEA, 2021b: BIB register, covering data for biomass delivered to the biogas plants and the biogas production. Data received from DEA, autumn 2021.

DEA, 2020: Available at: <https://ens.dk/en/our-services/statistics-data-key-figures-and-energy-maps/energy-infomaps> (Feb. 2022).

Dinuccio, E, Berg, W. & Balsari, P. 2008: Gaseous emissions from the storage of untreated slurries and the fractions obtained after mechanical separation. *Atm. Env.* 42, 2448-2459.

Dong, H. 2013: Pers. Comm. Dr. Hongmin Dong, medforfatter til IPCC Guidelines og ansat i CAAS - Chinese Academy of Agricultural Sciences, Beijing.

Elsgaard, L., Olsen, A.B. & Petersen, S.O. 2016: Temperature response of methane production in liquid manures and co-digestates, *Sci. of the Total Env.* 539, pp 78-84.

Hansen, T.L., Sommer, S.G., Gabriel, S. & Christensen, T.H. 2006: Methane production during storage of anaerobically digested municipal organic waste. *J. Environ. Qual.*, 35, 830-836.

Holm, M. 2015: Personal Communication. Unpublished data recorded in SEGESs Pig Research Centre, Vinkelvej 11, 8620 Kjellerup, Denmark.

Husted, S. 1994: Seasonal variation in methane emission from stored slurry and solid manures. *J Environ Qual.* 23:585-592.

IPCC, 2006: 2006 IPCC Guidelines for National Greenhouse Gas Inventories, Prepared by the National Greenhouse Gas Inventories Programme, Eggleston H.S., Buendia L., Miwa K., Ngara T. & Tanabe K. (eds). Published: IGES, Japan. Available at: <http://www.ipcc-nggip.iges.or.jp/public/2006gl/index.html> (Feb. 2022).

Kai, P., Birkmose, T. & Petersen, S. 2015: Slurry in Danish livestock Buildings. Report by AgroTech to the Danish Energy Agency, pp 32.

Møller, H.B. 2013: Final Report: Biogas potentials in manure and effects of pre-treatment (2009-1-010294). Report to the Danish Energy Agency.

Møller, Henrik Bjarne. 2016: Personal communication. Department of Engineering - Anaerobe Digestion Technologies, Aarhus University.

Møller, H.B. & Moset, V. 2015: Methane emissions from liquid manure storage – influence of temperature, storage time, substrate type and anaerobic digestion. Draft Final report 2015, Biogas Taskforce. Aarhus University, Department of Engineering.

Sommer, S.G., Møller, H.B. & Petersen, S.O. 2001: Reduktion af drivhusgas-emission fra gylle og organisk affald ved Biogasbehandling. DJF rapport - Husdyrbrug, 31, 53 pp. (In Danish).

Sommer S.G., Petersen S.O. & Møller H.B. 2004: Algorithms for calculating methane and nitrous oxide emissions from manure management. *Nutrient Cycling in Agroecosystems*. 69, 143-154.

Park, K.-H., Thompson, A.G., Marinier, M., Clark, K. & Wagner-Riddle, C. 2006: Greenhouse gas emissions from stored liquid swine manure in a cold climate. *Atm. Env.* 618-627.

Patni, N.K. & Jui, P.Y. 1987: Changes in solids and carbon content of dairy-cattle slurry in farm tanks. *Bio. Wastes*, 20, 11-34.

Petersen, S.O., Olsen, A.B., Elsgaard, L., Triolo, J.M. & Sommer, S.G. 2016: Estimation of Methane Emissions from Slurry Pits below Pig and Cattle Confinements. *PLoS ONE* 11(8): e0160968. doi:10.1371/journal.pone.0160968

Rodhe, L.K.K., Ascue, J., Willén, A., Persson, B.V. & Nordberg, Å. 2015: Greenhouse gas emissions from storage and field application of anaerobically digested and non-digested cattle slurry.

Rodhe, L., Ascue, J. & Nordberg, Å. 2009: Emissions of greenhouse gases (methane and nitrous oxide) from cattle slurry storage in Northern Europe. *IOP Conf. Ser. Earth Environ. Sci.* 8, 012019. doi:http://dx.doi.org/10.1088/1755-1315/8/1/012019

Rodhe, L.K.K., Abubaker, J., Ascue, J., Pell, M. & Nordberg, Å. 2012: Greenhouse gas emissions from pig slurry during storage and after field application in northern European conditions. *Biosyst. Eng.* 113, 379-394. doi:http://dx.doi.org/10.1016/j.biosystemseng.2012.09.010

Tong, X., Smith, L.H. & McCarty, P.L. 1990: Methane fermentation of selected lignocellulosic materials. *Biomass* 21: 239-255.

Wang, P.R., 2012: Referenceværdier: Døgn-, måneds-og årsværdier for regioner og hele landet 2001-2010, Danmark for temperatur, relativ luftfugtighed, vindhastighed, globalstråling og nedbør. Teknisk rapport 12-24 DMI.

Wang, Y., Dong, H., Zhu, Z., Li, L. Zhou, T., Jiang, B. & Xin, H. 2016: CH₄, NH₃, N₂O and NO emissions from stored biogas digester effluent of pig manure at different temperatures, *Agr. Eco. Env.* 217, 1-12.

Annex 3E - LULUCF

Table 3E.1 Estimation of forest percentage and forest area.

Table 3E.2 Estimation of forest area with a specific characteristic.

Table 3E.3 Estimation of diameter-height equations.

Table 3E.4 Estimation of quadratic mean diameter.

Table 3E.5 Estimation of biomass and carbon of trees.

Table 3E.6 Estimation of total biomass and carbon pools.

Table 3E.7 Estimation of biomass and carbon with a given characteristic.

Table 3E.8 Estimation of biomass and carbon content of dead wood.

Table 3E.9 Estimation of total biomass and carbon pools of dead wood.

Table 3E.10 Estimation of forest floor carbon.

Table 3E.11 Crops grown from Statistics Denmark in 2018 distributed regions.

Table 3E.12 Crop yield from Statistics Denmark in 2018 distributed regions, Hhg crop ha⁻¹.

Table 3E.13 Area input format to C-TOOL in 2018 in hectares.

Table 3E.14 Average annual temperatures for Denmark, 1977-2018.

Table 3E.15 Modelled half-lives and pool sizes in Rothamstedt.

List of figures

Figure 3E.1 Average annual temperatures for Denmark, 1977-2018, °C.

Figure 3E.2 The dynamics of hedgerows in the Danish Landscape 1990 to 2005. Blue colour indicates no changes, red colours are removed hedges and green colours are new hedges.

Figure 3E.2 Land Use Change 1888-2018.

Table 3E.1 Estimation of forest percentage and forest area.

Equation	Description
$X_j = \frac{A_j}{A_{15,j}}$	The forest percentage (X) of the j th sample plot (SSU) is estimated as the forested area (A) divided by the total area of the 15 m radius sample plot ($A_{15,j}$).
$\bar{X}_Z = \frac{1}{n_Z} \sum_Z X_j R_j$	Average forest percentage (\bar{X}) of all inventoried plots (SSU) with forest status Z based on aerial photos. R_j is an indicator variable that is 1 for inventoried plots and 0 otherwise. n_Z is the number of inventoried plots identified as forest or OWL from the air photos.
$\bar{X} = \frac{1}{n} \left(\sum_{j=1}^n X_j R_j + N_{21} \bar{X}_1 + N_{22} \bar{X}_2 \right)$	Overall average forest percentage ($\bar{\bar{X}}$). n is the total number of inventoried and non-inventoried sample plots. N_{21} and N_{22} is the number of non-inventoried sample plots with forest and OWL, respectively.
$A_{Forest} = \bar{\bar{X}} \cdot A_{Total}$	Total forest area. A_{Total} is the total land area, $\bar{\bar{X}}$ is the estimated forest percentage and A_{Forest} is the total forest area.

Table 3E.2 Estimation of forest area with a specific characteristic.

Equation	Description
$\bar{X}_k = \frac{\sum_{j=1}^n R_{jk} A_j}{\sum_{j=1}^n A_j}$	Proportion of the forest area with a given characteristic (\bar{X}_k). R_{jk} is an indicator variable which is 1 if the forest area on the j th sample plots has the k 'th characteristic and 0 otherwise. A_j is the sample plot area and n is the total number of inventoried sample plots with forest cover.
$A_k = \bar{X}_k \cdot A_{Forest}$	Total area with a given characteristic (A_k). \bar{X}_k is the estimated proportion of the forest area with the k 'th characteristic and A_{Forest} is the total forest area.

Table 3E.3 Estimation of diameter-height equations.

Equation	Description
$h_{ij} = 13 + (\bar{h}_j - 13) \cdot \exp\left(\alpha_1 \cdot \left(1 - \frac{\bar{d}_j}{d_{ij}} \right) + \alpha_2 \cdot \left(\frac{1}{\bar{d}_j} - \frac{1}{d_{ij}} \right) \right)$	Site specific dh-regression for calculating height of trees not measured for height. h_{ij} and d_{ij} is the height and diameter of the i 'th tree on the j 'th sample plot. \bar{h}_j and \bar{d}_j are the average height and diameter of trees measured for height on the j th sample plot. α_1 and α_2 are species and growth-region specific parameters
$h_{ij} = 13 + \beta_1 \cdot \exp\left(-\frac{\beta_2}{d_{ij}}\right)$	General dh-regression for calculating height of trees not measured for height. h_{ij} and d_{ij} is the height and diameter of the i 'th tree on the j 'th sample plot. β_1 and β_2 are species and growth-region specific parameters

Table 3E.4 Estimation of quadratic mean diameter.

Equation	Description
$g_{ij} = \frac{\pi}{4} d_{ij}^2$	Basal area (g) of the i th tree on the j th plot is calculated from the diameter at breast height (d) (1.3 m above ground) assuming a circular stem form.
$G_j = \sum_{i=1}^m \frac{1}{A_{c,ij}} g_{ij}$	Basal area per hectare (G) the j th sample plot is calculated as the scaled sum of individual tree basal areas. Basal area (g) of the i th tree on the j th sample plot is scaled according to the plot area ($A_{c,ij}$) of the c th concentric circle ($c=3,5; 10; 15$ m).
$N_j = \sum_{i=1}^m \frac{1}{A_{c,ij}}$	Stem number per hectare (N) the j th sample plot is calculated as the scaled number of individual trees. The i th tree on the j th sample plot is scaled according to the plot area ($A_{c,ij}$) of the c th concentric circle ($c=3,5; 10; 15$ m).
$D_{g,j} = \sqrt{\frac{4 G_j}{\pi N_j}}$	The mean squared diameter is calculated from the calculated basal area and stem number for each plot.

Table 3E.5 Estimation of biomass and carbon of trees.

Equation	Description
$v_{ij} = F(d_{ij}, h_{ij}, D_{g,j})$	The volume (v) of the i th tree on the j th sample plots is calculated using the existing volume functions (F) using the tree diameter and height and the quadratic mean diameter.
$B_{ij} = V_{ij} \cdot \text{Density}_{ij}$	Biomass (B) of the i th tree on the j th sample plot is estimated as the total volume (V_{tot}) times the species-specific density.
$E_{ij} = F(d_{ij}, h_{ij})$	Expansion factor model for beech and Norway spruce
$v_{tot,ij} = B_{ij} \cdot E_{ij}$	The total above and below ground volume (v_{tot}) of the i th tree on the j th sample plot. B_{ij} is the calculated aboveground biomass of the tree and E is the expansion factor.
$C_{ij} = B_{ij} \cdot 0.5$	Carbon of the i th tree on the j th sample plot is calculated as the biomass (B) times 0.5.

Table 3E.6 Estimation of total biomass and carbon pools.

Equation	Description
$V_{cj} = \frac{1}{A_{cj}} \sum_{i=1}^m R_{c,i} v_{ij}$	Volume, biomass or carbon per hectare (V) of the c th concentric circle on the j th sample plot ($c=3,5; 10; 15$ m). R_c is an indicator variable that is 1 if the i th tree is measured on the c th circle and 0 otherwise. $A_{c,ij}$ is the area of the j th sample plot and c th concentric circle; m is the number of trees on the j th sample plot.
$\bar{V}_c = \frac{\sum_{j=1}^n A_{cj} V_{cj}}{\sum_{j=1}^n A_{cj}}$	The average area weighted volume, biomass or carbon per hectare (\bar{V}) of the c th concentric circle. $A_{c,ij}$ is the area of the j th sample plot and c th concentric circle; n is the number of sample plots.
$\bar{\bar{V}} = \bar{V}_{3,5} + \bar{V}_{10} + \bar{V}_{15}$	The overall average volume, biomass or carbon per hectare ($\bar{\bar{V}}$) is estimated as the sum of the average volume, biomass or carbon per hectare (\bar{V}_c) for the three concentric circles ($c=3.5, 10$ and 15)
$V = \bar{\bar{V}} \cdot A_{Skov}$	Total volume, biomass or carbon V is the overall average volume, biomass or carbon per hectare ($\bar{\bar{V}}$) times the forest area A_{Forest} .

Table 3E.7 Estimation of biomass and carbon with a given characteristic.

Equation	Description
$V_{cj,k} = \frac{1}{A_{cj}} \sum_{i=1}^m R_{c,ij} R_{k,ij} v_{ij}$	Volume, biomass or carbon per hectare (V) with the k th characteristic of the c th concentric circle on the j th sample plot ($c=3,5; 10; 15$ m). R_c is an indicator variable that is 1 if the i th tree is measured on the c th circle and 0 otherwise. R_k is an indicator variable that is 1 if the tree has k th characteristic and 0 otherwise. $A_{c,ij}$ is the area of the j th sample plot and c th concentric circle; m is the number of trees on the j th sample plot.
$\bar{V}_{c,k} = \frac{\sum_{j=1}^n A_{cj} V_{cj,k}}{\sum_{j=1}^n A_{cj}}$	The average area weighted volume, biomass or carbon per hectare (\bar{V}) with the k th characteristic of the c th concentric circle. $A_{c,ij}$ is the area of the j th sample plot and c th concentric circle; m is the number of trees on the j th sample plot.
$\bar{\bar{V}}_k = \bar{V}_{3,5,k} + \bar{V}_{10,k} + \bar{V}_{15,k}$	The overall average volume, biomass or carbon per hectare with the k th characteristic ($\bar{\bar{V}}$) is estimated as the sum of the average volume, biomass or carbon per hectare ($\bar{V}_{c,k}$) for the three concentric circles ($c=3.5, 10$ and 15)
$V_k = \bar{\bar{V}}_k \cdot A_{Forest}$	Total volume, biomass or carbon with the k th characteristic (V_k) is the overall average volume, biomass or carbon per hectare ($\bar{\bar{V}}_k$) times the forest area A_{Forest} .

Table 3E.8 Estimation of biomass and carbon content of dead wood.

Equation	Description
$v_{s,ij} = F(d_{s,ij}, h_{s,ij}, D_{g,j})$	The volume (v_s) of the i th standing, dead tree on the j th sample plots is calculated using the existing volume functions (F) using the tree diameter and height and the squared mean diameter.
$v_{l,ij} = \frac{\pi}{4} d_{l,ij}^2 \cdot l_{l,ij}$	Volume of lying dead trees (v_l) is calculated as the length (l) and the i th tree on the j th sample plot times the cross sectional area. The cross sectional area is calculated from the mid-diameter (d) of the dead wood.
$B_{s,ij} = v_{s,ij} \cdot D_{ij} \cdot r_{k,ij}$	Biomass of the i th standing (B_s) or lying (B_l) tree on the j th sample plot is calculated as the volume (v_s or v_l) times the species specific density (D) and a k th reduction factor according to the structural decay of the wood observed in the field.
$B_{l,ij} = v_{l,ij} \cdot D_{ij} \cdot r_{k,ij}$	
$B_{s,tot,ij} = B_{s,ij} \cdot E_{ij}$	The total above and below ground volume ($B_{s,tot}$) of the i th standing, dead tree on the j th sample plot. v_s is the calculated biomass of the tree and E is the expansion factor.
$K_{s,ij} = B_{s,ij} \cdot 0.5$	Carbon in standing or lying dead wood (C_s or C_l) is calculated as the biomass (B_s or B_l) times 0.5.
$K_{l,ij} = B_{l,ij} \cdot 0.5$	

Table 3E.9 Estimation of total biomass and carbon pools of dead wood.

Equation	Description
$V_{D,cj} = \frac{1}{A_{cj}} \sum_{i=1}^m R_c v_{s,ij} + R_c v_{l,ij}$	Deadwood volume, biomass or carbon pools per hectare (V_D) for the c th circle and the j th sample plot. v_s and v_l is the volume of standing and lying deadwood respectively. R_c is an indicator variable that is 1 if the tree is measured in the c th circle and 0 otherwise. A_c is the sample plot area of the c th circle. m is the number of trees within the j th sample plot.
$\bar{V}_{D,c} = \frac{\sum_{j=1}^n A_{cj} V_{D,cj}}{\sum_{j=1}^n A_{cj}}$	The average area weighted deadwood volume, biomass or carbon per hectare (\bar{V}_D) of the c th concentric circle. $A_{c,j}$ is the area of the j th sample plot and c th concentric circle; n is the number of sample plots.
$\bar{\bar{V}}_D = \bar{V}_{D,3.5} + \bar{V}_{D,10} + \bar{V}_{D,15}$	The overall average deadwood volume, biomass or carbon per hectare ($\bar{\bar{V}}_D$) is estimated as the sum of the average volume, biomass or carbon per hectare ($\bar{V}_{D,c}$) for the three concentric circles ($c=3.5, 10$ and 15)
$V_D = \bar{\bar{V}}_D \cdot A_{Forest}$	Total deadwood volume, biomass or carbon V_D is the overall average deadwood volume, biomass or carbon per hectare ($\bar{\bar{V}}_D$) times the forest area A_{Forest} .

Table 3E.10 Estimation of forest floor carbon.

Equation	Description
$C_{floor,s,j} = Depth_j \cdot A_j \cdot B_s \cdot F_{s,j}$	Forest floor carbon ($C_{floor,s,j}$) of the s th species, on the j th plot with an area of A . B_s is the species specific forest floor density and F is the fraction of species s .
$C_{floor,j} = \sum_{s=1}^k C_{floor,s,j}$	Total forest floor carbon on the j th plot.
$C_{floor} = \frac{\sum_{j=1}^n C_{floor,j}}{\sum_{j=1}^n A_j} \cdot A_{Forest}$	Total forest floor carbon is estimated as the area weighted average forest floor carbon content times the total forest area.

Table 3E.11 Crops grown from Statistics Denmark in 2020 distributed on regions, ha.

	All Denmark	Province Nord- sjælland	Province Bornholm	Province Sjælland	Province Fyn	Province Syd- jylland	Province Øst- jylland	Province Vest- jylland	Region Nord- jylland
Agriculture and horticulture total	2619987	66427	34306	464282	219392	559336	345874	443087	487284
1. Cereals for the production of grain	1363958	31467	21456	272352	127914	250276	213016	205820	241655
1.1 Common wheat	501733	12461	11712	128350	61271	75054	87927	44734	80223
1.1.1 Common winter	483445	11695	10871	123977	59813	70751	86097	43209	77032
1.1.2 Common spring wheat	18288	766	842	4373	1458	4303	1831	1525	3191
1.2 Barley	651545	12298	8455	125225	53397	126374	93303	121696	110796
1.2.1 Winter barley	87665	1603	1462	8855	8137	17245	23586	10274	16504
1.2.2 Spring barley	563879	10695	6993	116370	45260	109130	69718	111422	94292
1.3 Rye	115002	3754	375	9067	7544	23181	19039	23536	28508
1.4 Oats	74633	2500	731	7040	4431	20871	8612	12105	18345
1.5 Triticale	6479	124	..	452	187	632	2204	575	2271
1.6 Grain maize and corn-cob mix	6195	76	8	871	651	2187	949	1220	232
1.7 Mixed grains and other cereals	8372	254	143	1347	434	1977	981	1956	1280
2. Pulses	27273	547	688	5643	1944	6310	3776	3832	4534
2.1 Pulses for the production of grain	7404	172	86	3517	437	1192	644	710	646
2.2 Horse beans	19170	337	600	1974	1420	4867	3073	3060	3839
2.3 Other pulses	700	153	87	252	58	61	49
3. Root crops	99867	689	61	34573	2375	17414	3371	27579	13805
3.1 Potatoes	62679	462	56	2353	1325	16150	3039	26859	12435
3.1.1 Seed potatoes	9205	777	149	1993	168	4647	1431
3.1.2 Potatoes for manufacturing	42304	30	..	162	346	11511	2195	19122	8898
3.1.3 Potatoes for human consumption	11170	393	15	1414	830	2645	676	3090	2107
3.2 Sugar beets	33064	32152	913
3.3 Beets and other root crops for fodder	4123	227	..	68	137	1264	333	720	1370
4. Industrial crops	147031	5020	2572	39220	18444	21051	25902	13637	21185
4.1 Rape	145726	4996	2556	38639	18409	20913	25662	13517	21034
4.1.1 Winter rape	144708	4994	2556	38480	18318	20636	25632	13410	20683
4.1.2 Spring rape	1018	159	91	277	..	107	351
4.2 Flax	72
4.3 Other industrial crops	1233	24	..	580	33	138	240	50	151
5. Seeds for sowing	106308	1842	2645	38556	20267	7723	11717	12219	11339
6. Temporary grass and green fodder	520873	7969	4167	23502	22000	184673	39848	118600	120115
6.1 Lucerne	873	57	..	192	72	318	62	43	129
6.2 Green maize	188359	520	1695	4664	9843	82878	11033	44106	33621
6.3 Cereals and pulses harvested green	49259	351	178	1249	828	15396	3141	12080	16035
6.4 Temporary grass and clover	282383	7041	2294	17397	11258	86080	25612	62371	70330
7. Horticultural crops	19892	793	62	5810	5200	1503	2787	2566	1172
7.1 Vegetables grown outdoors	9476	417	18	1697	2271	278	2151	1847	797
7.2 Peas for human consumption	3228	2281	825	21	15	48	27
7.3 fruits and berries	5218	265	39	1661	1618	625	504	220	286
7.3.1 Apples	1489	91	12	448	635	111	113	39	41
7.3.2 Pears	305	16	..	114	125	13	24	8	4
7.3.3 Strawberries	1106	68	..	381	186	157	119	69	127
7.3.4 Cherries	640	13	..	306	226	73	12
7.3.5 Blackcurrants	463	20	..	133	127	82	45	43	11
7.3.6 Redcurrants	185	76	63	18	9
7.3.7 Other fruits and berries	1031	43	25	204	256	171	182	58	92
7.4 Bulbs and flowers	71	40	6	4	6
7.5 Nursery area	1899	92	..	132	481	575	110	447	62
8. Permanent grassland	222405	14266	1647	27528	13069	50309	28199	39668	47720
9. Christmas trees and decorative greenery	22319	334	86	2969	2415	5280	4424	3036	3774
10. Fallow land	81727	3310	900	13596	5196	12927	12010	14260	19529

Table 3E.12 Crop yield from Statistics Denmark in 2020 distributed regions, Hhg crop ha⁻¹.

Crop	Capital_								
	Bornholm	North Zealand	East Jutland	Fyn	North Jutland	South Jutland	West Jutland	Zealand	
Flax	18.5	34	32.8	31.1	34.4	31.2	29.6	33.2	
Green cereals for silage	186	186	185	193	194	178	191	229	
Green maize for silage	386	386	333	376	305	329	321	379	
Lucerne	525	542	538	561	566	519	558	668	
Oat and mixed cereals	58.4	63.4	55.5	59.5	56.1	58.7	50.1	55.9	
Other seeds for industrial use	18.5	34	32.8	31.1	34.4	31.2	29.6	33.2	
Permanent grass outside rotation	161	131	90	99	86	114	92	128	
Potatoes for consumption	496	496	306	382	225	423	394	281	
Potatoes for seed	400	300	202	353	383	289	273	267	
Potatoes for starch production	400	492	592	534	493	489	489	492	
Pulses for maturity	48.2	36.8	40.8	40.7	42.4	42	36.8	45.9	
Rye	57.6	74.2	63.2	68.2	60.9	55.9	57.6	72.1	
Seeds for sowing	12.9	12.9	12.9	12.9	12.9	12.9	12.9	12.9	
Spring barley	70	61.5	63.8	66.4	59.6	61.2	61	69	
Spring rape	18.5	34	32.8	31.1	34.4	31.2	29.6	33.2	
Spring wheat	38.4	49	50.7	44.7	59.1	53.7	63.2	57.8	
Sugar beet for sugar production	525	521.6	580.9	739	616.3	0	654	770.8	
Sugar beets for feeding	531	531	601	691	682	846	506	517	
Triticale	62.8	62.8	61.2	62.8	69.1	62.8	74.2	50.2	
Vegetables grown in the open, total	18.5	34	32.8	31.1	34.4	31.2	29.6	33.2	

Table 3E.13 Area input format to C-TOOL in 2018 in hectares. Soil Group 1 represents sandy soils, 2 is sandy loam and 3 is loamy sand. Soil Group 4 is organic soils with >6% SOC. Organic soils are NOT included in the estimation of changes in SOC in mineral soils (Modelling with C-TOOL).

Crop type	Soil Group	Copenhagen and				Eastern	Southern	Western	Zealand	Northern
		North Zealand	Bornholm	Funen	Jutland	Jutland	Jutland	Jutland		
Bulbs and flowers	1	9		73	621	357	1013	11	141	
Bulbs and flowers	2	281	3	1779	1260	181	646	609	593	
Bulbs and flowers	3	178	143	1646	215	129	87	3835	1	
Bulbs and flowers	4	19		11	30	8	11	42	21	
Fallow land	1	199	86	1272	7970	20400	21736	2323	13667	
Fallow land	2	9560	514	6634	14103	13888	10044	11976	28957	
Fallow land	3	5594	2197	5910	6365	13530	3043	16437	2128	
Fallow land	4	2091	126	2934	9412	12171	12776	7269	14753	
Flax	1				7	28	67		46	
Flax	2	16	0	1	69	7	29	42	65	
Flax	3		2	0	53	3		89	1	
Flax	4	0	0		46	6	1	0	0	
Grass and clover fields in rotation	1	49	15	316	7320	37036	28669	237	8187	
Grass and clover fields in rotation	2	4441	208	4483	17452	26682	21756	3818	41804	
Grass and clover fields in rotation	3	1782	1585	5704	7145	13528	3400	8560	3309	
Grass and clover fields in rotation	4	545	7	902	3954	9115	7054	1845	9522	
Green cereals for silage	1	1		30	829	3689	3655	2	624	
Green cereals for silage	2	152	3	296	1769	2859	2581	357	3778	
Green cereals for silage	3	60	146	312	504	663	434	608	347	
Green cereals for silage	4	9	2	12	198	637	422	45	471	
Green maize for silage	1	1	3	170	4235	46537	25403	10	4384	
Green maize for silage	2	417	300	4363	8761	28902	17688	1425	22854	
Green maize for silage	3	58	1406	5898	2134	5136	1862	3950	1586	
Green maize for silage	4	29	3	172	253	3926	1325	356	1228	
Lucerne	1			1	18	142	8		4	
Lucerne	2	47		40	40	205	33	38	29	
Lucerne	3	23	3	23	7	5	0	150	28	
Lucerne	4	0		0	1	18	3	4	1	
Nursery area	1	9		73	621	357	1013	11	141	
Nursery area	2	281	3	1779	1260	181	646	609	593	
Nursery area	3	178	143	1646	215	129	87	3835	1	
Nursery area	4	19		11	30	8	11	42	21	
Oat and mixed cereals	1	3	2	36	1405	6697	5006	33	1395	
Oat and mixed cereals	2	1391	40	1396	4795	6935	4843	1482	12071	
Oat and mixed cereals	3	918	682	2859	3138	6342	1505	5578	1556	
Oat and mixed cereals	4	47	7	70	284	1308	867	241	1778	
Other crops and fallow land	1	199	86	1272	7970	20400	21736	2323	13667	
Other crops and fallow land	2	9560	514	6634	14103	13888	10044	11976	28957	
Other crops and fallow land	3	5594	2197	5910	6365	13530	3043	16437	2128	
Other crops and fallow land	4	2091	126	2934	9412	12171	12776	7269	14753	
Other seeds for industrial use	1				34	17	7	2	8	
Other seeds for industrial use	2	12	0	89	8	7	2	24	19	
Other seeds for industrial use	3		14	85	5	22	0	394		
Other seeds for industrial use	4			0	1	0	0	15	0	
Permanent grass outside rotation	1	199	86	1272	7970	20400	21736	2323	13667	
Permanent grass outside rotation	2	9560	514	6634	14103	13888	10044	11976	28957	
Permanent grass outside rotation	3	5594	2197	5910	6365	13530	3043	16437	2128	
Permanent grass outside rotation	4	2091	126	2934	9412	12171	12776	7269	14753	
Potatoes for consumption	1	0		64	82	2041	2350	18	509	
Potatoes for consumption	2	295	13	526	596	435	654	672	815	
Potatoes for consumption	3	78	4	232	73	111	7	707	13	
Potatoes for consumption	4	6		4	2	90	73	15	757	
Potatoes for seed	1			4	137	1183	2410	0	155	
Potatoes for seed	2	38		81	496	785	1527	91	1250	
Potatoes for seed	3	0		64	102	198	92	556	42	
Potatoes for seed	4	0		1	2	37	88	1	51	
Potatoes for starch production	1			0	626	8151	13968		647	
Potatoes for starch production	2			192	1493	2026	3529		7232	
Potatoes for starch production	3			111	261	95	160	6	88	
Potatoes for starch production	4			1	58	441	581		728	
Pulses for maturity	1	2	8	17	341	1973	1666	16	223	

Crop type	Soil Group	Copenhagen and			Eastern Jutland	Southern Jutland	Western Jutland	Zealand	Northern Jutland
		North Zealand	Bornholm	Funen					
Pulses for maturity	2	135	2	614	1653	1923	1557	711	3273
Pulses for maturity	3	298	686	1380	1812	2363	610	5056	435
Pulses for maturity	4	6	4	24	72	222	94	85	275
Pulses, fodder cabbage etc	1			0	0		10		0
Pulses, fodder cabbage etc	2			1	1		0	3	12
Pulses, fodder cabbage etc	3		0	0	0			2	
Pulses, fodder cabbage etc	4			0	0			4	0
Rye	1	98	9	389	6911	13220	14578	222	3737
Rye	2	2664	76	4976	12923	7603	8262	3868	19434
Rye	3	848	278	2130	1998	1499	500	4704	658
Rye	4	53	2	68	411	1045	761	489	866
Seeds for sowing	1	0	0	139	945	1896	4842	118	818
Seeds for sowing	2	966	144	5126	6129	2316	5079	4192	8280
Seeds for sowing	3	645	2376	14811	5090	3446	1734	33719	781
Seeds for sowing	4	19	7	164	267	137	485	594	377
Set aside with grass	1	10	15	88	1591	4440	4406	466	1505
Set aside with grass	2	588	42	1321	3996	3534	2720	2440	8479
Set aside with grass	3	279	306	1160	1920	2951	383	4008	591
Set aside with grass	4	185	13	329	1927	1891	1903	1496	3276
Set aside, total	1	199	86	1272	7970	20400	21736	2323	13667
Set aside, total	2	9560	514	6634	14103	13888	10044	11976	28957
Set aside, total	3	5594	2197	5910	6365	13530	3043	16437	2128
Set aside, total	4	2091	126	2934	9412	12171	12776	7269	14753
Spring barley	1	39	23	448	9006	45646	59852	422	6306
Spring barley	2	6038	345	14331	39184	36873	39560	16910	64424
Spring barley	3	4249	6578	30375	25747	21486	8958	98326	11048
Spring barley	4	256	31	652	2232	5395	5399	2397	6656
Spring rape	1				23	203	70		2
Spring rape	2			36	50	51	27	1	189
Spring rape	3			55	15	8	2	160	58
Spring rape	4			0	1	15	0	0	39
Spring wheat	1	0	4	3	135	1452	843	106	107
Spring wheat	2	446	41	329	718	1149	454	729	1987
Spring wheat	3	274	797	1075	961	1415	153	3317	413
Spring wheat	4	22	2	45	324	210	124	357	535
Sugar beet for sugar production	1			3		5	11	148	
Sugar beet for sugar production	2	19		145	0		4	2510	
Sugar beet for sugar production	3	2		689	12	5		29420	
Sugar beet for sugar production	4			15		0		295	
Sugar beets for feeding	1		2	0	29	774	388		86
Sugar beets for feeding	2	11	4	75	239	382	286	15	1200
Sugar beets for feeding	3	12	0	64	82	69	20	52	24
Sugar beets for feeding	4	0		1	2	25	10	0	30
Triticale	1		9	45	430	988	901	27	267
Triticale	2	149	19	262	1789	839	620	439	2195
Triticale	3	144	93	221	789	434	84	1116	207
Triticale	4	11	12	11	249	99	61	62	198
Vegetables grown in the open, total	1	9		73	621	357	1013	11	141
Vegetables grown in the open, total	2	281	3	1779	1260	181	646	609	593
Vegetables grown in the open, total	3	178	143	1646	215	129	87	3835	1
Vegetables grown in the open, total	4	19		11	30	8	11	42	21
Winter barley	1	3	19	139	2208	4133	3726	5	892
Winter barley	2	974	178	3215	11798	4491	4778	1955	11228
Winter barley	3	624	1274	4721	10230	8504	1509	6779	2954
Winter barley	4	47	1	86	267	336	162	147	493
Winter rape	1	11	2	74	2051	2524	2974	114	1207
Winter rape	2	2771	111	6137	13732	5476	6847	6531	14085
Winter rape	3	1908	2437	11999	10853	12521	3021	31960	3079
Winter rape	4	108	6	155	438	419	225	590	774
Winter wheat	1	13	41	385	4541	7574	9505	521	3171
Winter wheat	2	6440	407	17203	40518	16027	22228	17029	48774
Winter wheat	3	4503	10362	41835	42465	45792	10035	105333	16485
Winter wheat	4	261	33	561	2077	1744	942	1918	4716

Table 3E.14 Average annual temperatures for Denmark, 1977-2020, °C.

Year	Average	Year	Average
1977	7.7	2000	9.2
1978	7.7	2001	8.2
1979	7.7	2002	9.2
1980	7.2	2003	8.7
1981	7.2	2004	8.7
1982	8.0	2005	8.8
1983	8.4	2006	9.4
1984	8.0	2007	9.4
1985	6.5	2008	9.4
1986	7.0	2009	8.8
1987	6.6	2010	6.9
1988	8.5	2011	8.9
1989	9.2	2012	8.3
1990	9.2	2013	8.3
1991	8.1	2014	10.0
1992	9.0	2015	9.1
1993	7.6	2016	9.0
1994	8.6	2017	8.9
1995	8.2	2018	9.5
1996	6.8	2019	9.4
1997	8.5	2020	9.7
1998	8.2		
1999	8.9		

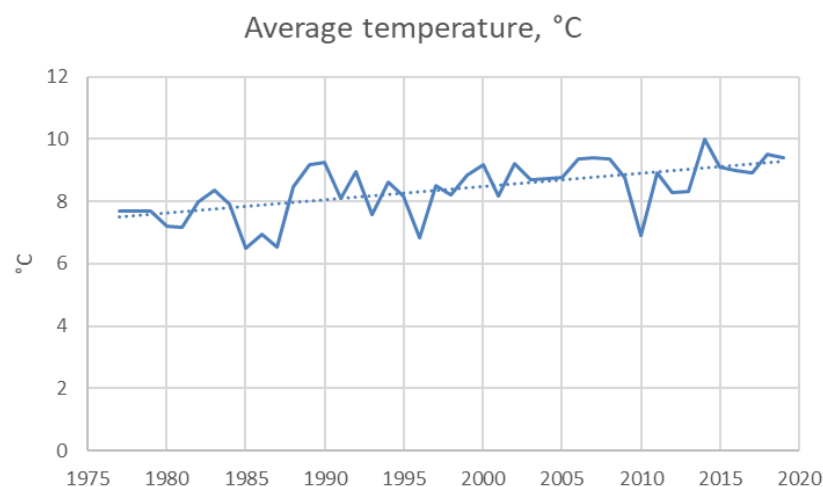

Figure 3E.1 Average annual temperatures for Denmark, 1977-2019, °C.

Hedgerows

Since the beginning of the early 1930s, governmental subsidiaries have been given to increase the area with hedgerows to reduce soil erosion. In the 1950-60's, 6-9 million single rowed confers, mainly white spruce (*Picea glauca*), were planted annually. From around 1965, the annual rate decreased sharply to almost zero. Instead new hedges were made of broad leaf trees/plants but only to around 2-3 million trees. This can be converted to annually financial support given to approximately 400-800 km of hedgerow. In the latter years, financial support has only been given to approximately 100 ha. From 2014, only minor subsidized areas has been erected. Currently there is a small annual governmental subsidy available for approximately 100 ha per year.

The new updated LiDAR-model for hedges and biotopes not qualifying for forest is based on LiDAR measurements in 2006 and 2014/15. Information on the exact location of subsidized hedge planting and some of the removal is available from 2007 and onwards. In the period from 2006 to 2014/15 is the area with removed hedges estimated from what is missing in the 2014/15 LiDAR measurements compared to 2006.

Future updates with this technology will be available because the Danish Government has decided to make new LiDAR measurements in a five years rotation for the whole country starting 2019.

Transition period and effect on eventual on under- or overestimation of the C source/sink in the period up to 1990

The Danish inventory has implemented an annual Land Use Matrix from 1990 and onwards using a 30 years transition period for estimating emissions from Land Use Change (LUC). This is different from the 20 years transition period as mentioned in the 2006 IPCC Guidelines.

The choice of transition period has mainly two effects on the inventory.

The first issue is a distribution of the reported emission between “Land remaining in the same Land category” and the subcategory “Land converted to.” For all emission estimates except for the carbon stock in soils is used either a distribution of the known carbon stock as in forest or the instant oxidation approach is used. For all living and dead biomass Denmark is using instant oxidation. No carrying over model of living biomass is used, except for hedges where an area based Tier 3 carbon stock model is developed. Thus, the emission/sink from living and dead biomass has no impact on the emission estimate for the base year. An eventual over- or underestimation of the emission will therefore only occur from mineral soils in transition.

For mineral soils is the default transition period of 20 years when land use change is taking place not appropriate under the cold temperate conditions in Denmark where the average annual temperature is around 9 °C.

The main LUC in Denmark is from

- Cropland (CL) to Settlement (SE) with an indicative loss of carbon stock/ha
- CL to Forest land (FL) with an indicative increase in the carbon stock/ha

Figure 3E.2 shows the apparent Land Use Change from 1888 to 2018 (Statistics Denmark 1896, 1919, 1952, 1990). As can be seen has the area with FL increased substantially as well as the SE area. The total area with CL is more or less constant but the GL has decreased substantially. Approximately half of the 900 000 ha GL in 1888 were heathland. Of this is only 70 000 ha left today. The remaining heathland has been turned into agricultural soils. According to our forest statistics from 1954 (Vivian Kvist Johannesen, pers. com) has about 55 % of the afforestation from 1954 to now taken place on CL and 32 % on which we consider as GL. The afforestation on CL has mainly taken place on the fertile land around the cities and the afforestation on GL were mainly on the sandy heathland with Norwegian spruce.

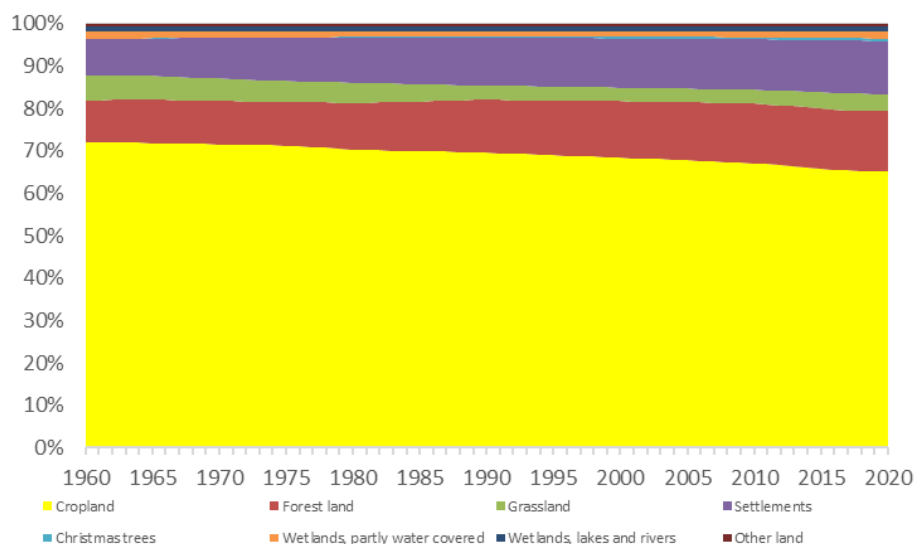

Figure 3E.2 Land Use Change 1960-2020.

Very few data is available on the carbon stock in the different soil types and it is therefore very difficult to estimate Danish default reference carbon stocks. The earliest representative data we have on agricultural land is from the beginning of the 1960'ies from our agricultural research stations (Lamm, 1971). Forty-nine of these soil samples can be considered as mineral. They had an average C stock (0-100 cm) of 103.3 tonnes C/ha (SE \pm 33.8). The sandy soils showed both low and high values, depending on its podsolization. In Danish soil sampling grid from 1986 (approximately 500 samples), the weighted average C stock was 120.8 tonnes C/ha indication a build-up in the period from the 1960's to the 1980's. This coincided with the increased fertilization in agriculture leading to higher yields.

Long-term agricultural experiments at Rothhamsted in the United Kingdom has shown that >95 % of the Soil Organic Matter (SOM) has a half-life ($t_{1/2}$) of more than 49 years (Jenkinson and Rayner, 1977), Table 1. Both the Roth-C model and C-TOOL (Petersen et al., 2002) is based on the long-term experiments. All models are using prediction of the age of the soil carbon. Basically, the models are operating with fast pools (crop residue), medium reacting pools and slow acting pools. Within the time frame of the inventories submitted to UNFCCC is it mainly the medium pools which are important for understanding the carbon sink/source from LUC. The fast pools are normally considered as crop residues or litter and the slow reacting pools is of minor interest for inventory purposes because of $t_{1/2} \gg 100$ years. Hence, the medium pools is the single most important factor for the reporting obligation. According to the data from Rothhamsted (Jenkinson and Rayner 1977) and Denmark (Petersen et al., 2002) account the medium pool to approximately 45 % of the total C stock. New unpublished data in Denmark has estimated that on sandy soils (former heathland) is the medium pool even lower (Arezoo T., Pers. comm).

Table 3E.17 Modelled half-lives and pool sizes in Rothamsted (Jenkinson and Rayner, 1977).

	t½, yr	t ha-1 (0-23 cm)	Fraction
Decomposable Plant Material, DPM	0.165	0.01	0.0004
Resistant Plant Material, RPM	2.31	0.47	0.0194
Soil Biomass	1.69	0.28	0.0115
Physically stabilized Organic Matter POM	49.5	11.3	0.4658
Chemically Stabilized Organic Matter, COM	1980	12.2	0.5029
Total		24.3	1.0000

The Danish inventory are using C-TOOL to estimate the C turnover in agricultural soils. As the major Land Use Conversion is from agricultural land to SE, this model may be able to predict loss from agricultural soils when land is transferred to SE. When looking on the large Danish conversion from unfertile sandy heathland to fertile CL and the afforestation on this land it is currently a difficult task to come with any conclusive figures on the loss and gain from mineral soils combined with LUC.

Technical documentation for C-TOOL

C-TOOL is a simple tool for simulation of soil carbon turnover. The technical documentation for C-TOOL with parameterization is provided and documented by Taghizadeh-Toosi et al., 2015 (https://agro.au.dk/fileadmin/DIF/Agro/Medarbejderportal_AGRO/Sektioner/KLIMA/C-TOOL_Documentation.pdf)

References

Jenkinson, D.S. & Rayner, J.H., 1977: The turnover of soil organic matter in some of the Rothamsted classical experiments. *Soil Science* 123: 298–305.

Lamm, C.G., 1971: The Danish soil library, *Tidskrift for Planteavl*, 75, 703-720.

Petersen, B.M., Olesen, J.E. & Heidmann, T., 2002: A flexible tool for simulation of soil carbon turnover. *Ecol. Model.* 151, 1–14

Taghizadeh-Toosi, A., Christensen, B.T., Hutchings, N.J., Vejlin, J. Kätterer, T. Glendining, M. & Olesen, J.E., 2014: C-TOOL: A simple model for simulating whole-profile carbon storage in temperate agricultural soils, *Ecological Modelling*, 292, pp 11-25. Available at:

https://agro.au.dk/fileadmin/DJF/Agro/Medarbejderportal_AGRO/Sektioner/KLIMA/C-TOOL_Documentation.pdf

Vivian Kvist Johannesen, pers. Com. University of Copenhagen, Department of Geosciences and Natural Resource Management.

Annex 3F - Waste

Annex 3F-1: Emissions from the waste sector, 1990-2020

Annex 3F-2: Solid Waste Disposal, 5.A

Annex 3F-3: Biological treatment of Solid Waste, 5.B

Annex 3F-4: Incineration and open burning of waste, 5.C

Annex 3F-5: Wastewater treatment and discharge, 5.D

Annex 3F-6: Other, 5.E

Annex 3F-1 Emissions from the waste sector, 1990-2020

Table 3F-1.1 Emissions for the waste sector, kt CO₂ equivalents.

See:

<https://envs.au.dk/en/faglige-omraader/luftforurening-udledninger-og-effekter/udledning-af-luftforurening/greenhouse-gases/supporting-documentation>

Annex 3F-2 Solid Waste Disposal on Land, 6A

Table 3F-2.1 All nationally produced waste categorised after handling method, collected for the ISAG database 1994-2009 and the new waste reporting system for 2010-2020.

Table 3F-2.2 Annual amounts of deposited waste, gross methane emission, recovered methane collected for biogas production, oxidised methane in the top layer and resulting net emission for the Danish SWDS.

Table 3F-2.3 Annual amounts of deposited inert and decomposable waste allocated according to 18 identified waste types characterised according to their DOCi and decomposition rate quantified by their half-life times, t_{1/2}.

Table 3F-2.4 European waste codes allocated according to 18 characterised waste types.

Table 3F-2.5 Fractional distribution of waste types for the whole time series 1990-2020.

See:

<https://envs.au.dk/en/faglige-omraader/luftforurening-udledninger-og-effekter/udledning-af-luftforurening/greenhouse-gases/supporting-documentation>

Annex 3F-3 Biological Treatment of Solid Waste, 5.B

Table 3F-3.1 National emissions from composting – 1990 to 2020, tonnes.

Table 3F-3.2 Activity data composting, kt.

Table 3F-3.3 Activity data and methane emissions from anaerobic digestion at manure-based biogas plants.

See:

<https://envs.au.dk/en/faglige-omraader/luftforurening-udledninger-og-effekter/udledning-af-luftforurening/greenhouse-gases/supporting-documentation>

Annex 3F-4 Incineration and open burning of waste, 5. C

Table 3F-4.1 presents the greenhouse gas emissions from 5.C Incineration and open burning of waste for 1990-2020.

Table 3F-4.2 presents the activity data for human cremation for 1990-2020.

Table 3F-4.3 presents the activity data for animal cremation for 1990-2020.

See:

<https://envs.au.dk/en/faglige-omraader/luftforurening-udledninger-og-effekter/udledning-af-luftforurening/greenhouse-gases/supporting-documentation>

Annex 3F-5 Wastewater treatment and discharge, 5.D

Table 3F-5.1 Produced, recovered and emitted CH₄ from wastewater treatment, kt, 1990-2020.

Table 3F-5.2 N₂O emissions from wastewater, tonnes, 1990-2020.

Table 3F-5.3 Time series for the contribution from industrial wastewater to the influent TOW at Danish wastewater treatment plants, population number, measured BOD and COD data and resulting COD/BOD ratio, 1990-2020.

Table 3F-5.4 Nitrogen content in the influent and effluent wastewater, tonnes.

See:

<https://envs.au.dk/en/faglige-omraader/luftforurening-udledninger-og-effekter/udledning-af-luftforurening/greenhouse-gases/supporting-documentation>

Annex 3F-6 Other. 5.E.1 Accidental fires

Table 3F-6.1 Overall emission of greenhouse gasses from accidental fires, 1990-2020.

Table 3F-6.2 Occurrence of accidental fires, 1990-2020.

Table 3F-6.3 Accidental building fires full scale equivalent activity data.

Table 3F-6.4a Emission factors for accidental detached building fires, 1990-2014 and the average emission factor, used for alle years.

Table 3F-6.4b Emission factors for accidental undetached building fire, 1990-2014 and the average emission factor, used for alle years.

Table 3F-6.4c Emission factors for accidental apartment building fires, 1990-2014 and the average emission factor, used for alle years.

Table 3F-6.5 Average floor space in building types, 1990-2014. Used to estimate average emission factors for building fires.

Table 3F-6.6a Number of nationally registered vehicles and full scale equivalent vehicle fires.

Table 3F-6.6b Number of nationally registered vehicles and full scale equivalent vehicle fires.

Table 3F-6.6c Number of nationally registered vehicles and full scale equivalent vehicle fires.

Table 3F-6.7 Average weight of different vehicle categories, kg, 1990-2020.

Table 3F-6.8 Burnt mass of different vehicle and machine categories, tonnes.

See:

<https://envs.au.dk/en/faglige-omraader/luftforurening-udledninger-og-effekter/udledning-af-luftforurening/greenhouse-gases/supporting-documentation>

Annex 4 - Information on the energy statistics

This description of the Danish energy statistics has been prepared by DCE in cooperation with the Danish Energy Agency (DEA) as background information to the Danish National Inventory Report (NIR).

The Danish energy statistics system

DEA is responsible for the Danish energy balance. Main contributors to the energy statistics outside DEA are Statistics Denmark and Danish Energy Association (before Association of Danish Energy Companies). The statistics are performed using an integrated statistical system building on an Access database and Excel spreadsheets.

The DEA follows the recommendations of the International Energy Agency as well as Eurostat.

The national energy statistics is updated annually and all revisions are immediately included in the published statistics, which can be found on the DEA homepage¹. It is an easy task to check for breaks in a series because the statistics is 100 % time-series oriented.

The national energy statistics does not include Greenland and the Faroe Islands.

For historical reasons, DEA receive monthly information from the Danish oil companies regarding Danish deliveries of oil products to Greenland and Faroe Islands. However, the monthly (MOS) and annual (AOS) reporting of oil statistics to Eurostat and IEA exclude Greenland and Faroe Islands. For all other energy products, the Danish figures are also excluding Greenland and Faroe Islands.

Reporting to the Danish Energy Agency

The Danish Energy Agency receives monthly statistics for the following fuel groups:

- Crude oil and oil products
 - Monthly data from 46 oil companies, the main purpose is monitoring oil stocks according to the oil preparedness system
- Natural gas
 - Fuel/flare from platforms in the North Sea
 - Natural gas balance from the regulator Energinet.dk (National monopoly)
- Coal and coke
 - Power plants (94 %)
 - Industry companies (4 %)
 - Coal and coke traders (2 %)
- Electricity
 - Monthly reporting by e-mail from the regulator Energinet.dk (National monopoly)
 - The statistics covers:

¹ <https://ens.dk/en/our-services/statistics-data-key-figures-and-energy-maps/annual-and-monthly-statistics>

- Production by type of producer
- Own use of electricity
- Import and export by country
- Domestic supply (consumption + distribution loss)
- Town gas (quarterly) from two town gas producers
- The large central power plants also report monthly consumption of biomass

Annual data includes renewable energy including waste. The DEA conducts a biannual survey on wood pellets and wood fuel. Statistics Denmark conducts biannual surveys on the energy consumption in the service and industrial sectors. Statistics Denmark prepares annual surveys on forest (wood fuel) & straw.

Other annual data sources include:

- DEA
 - Survey on production of electricity and heat and fuels used
 - Survey on end use of oil
 - Survey on end use of natural gas
 - Survey on end use of coal and coke
- DCE, Aarhus University
 - Energy consumption for domestic air transport
- Danish Energy Association (Association of Danish Energy companies)
 - Survey on electricity consumption
- Ministry of Taxation
 - Border trade
- Centre for Biomass Technology
 - Annual estimates of final consumption of straw and wood chips

Annual revisions

In general, DEA follows the same procedures as in the Danish national account. This means that normally only figures for the last two years are revised.

Aggregating the energy statistics on SNAP level

The sectors used in the official energy statistics have been mapped to SNAP categories, used in the Danish emission database. DCE aggregates the official energy statistics to SNAP level based on a source correspondence table.

In cooperation between DEA and DCE, a fuel correspondence table has been developed mapping the fuels used by the DEA in the official energy statistics with the fuel codes used in the Danish national emission database. The fuel correspondence table between fuel categories used by the DEA, DCE and IPCC is presented in Annex 3A-3.

The mapping between the energy statistics and the SNAP and fuel codes used by DCE can be seen in the table below.

Table 3A-9.1 Correspondence between the Danish national energy statistics and the SNAP nomenclature (only stationary combustion part shown).

Unit: TJ	End-use		Transformation	
	SNAP	Fuel	SNAP	Fuel
Energy Sector				
Extraction and Gasification				
- Extraction				
- - Natural Gas	010504	301A		
- Gasification				
- - Biogas, Landfill				
- - Biogas, Other				
- - Electricity				
Refineries				
- Used for Refining				
- - Crude Oil				
- - Refinery Feedstocks				
- - Electricity				
- - District Heating				
- Own Use				
- - Refinery Gas	010306	308A		
- - LPG	010306	303A		
- - Gas-/Diesel Oil	010306	204A		
- - Fuel Oil	010306	203A		
- Net Production				
- - Refinery Gas				
- - LPG				
- - Naphtha (LVN)				
- - Aviation Gasoline				
- - Motor Gasoline				
- - JP4				
- - Other Kerosene				
- - JP1				
- - Gas-/Diesel Oil				
- - Fuel Oil				
- - Petroleum Coke				
- - White Spirit				
- - Lubricants				
- - Bitumen				
- - Biodiesel				
Distribution				
- Electricity Used in Distribution				
- - Electricity Distribution				
- - District Heating Distribution				
- - Gas Distribution				
Transformation Sector				
Large-scale Power Units				
- Fuels Used for Power Production				
- - Gas-/Diesel Oil			010100	204A
- - Fuel Oil			010100	203A
- - Electricity Plant Coal			010100	102A
- - Straw			010100	117A
- Own Use				
- - Electricity				
- Gross Production				
- - Electricity				
Large-Scale CHP Units				
- Fuels Used for Power Production				
- - Refinery Gas			010300	308A
- - LPG			010100	303A
- - Naphtha (LVN)			010100	210A
- - Gas-/Diesel Oil			010100	204A
- - Fuel Oil			010100	203A
- - Petroleum Coke			010100	110A
- - Orimulsion			010100	225A
- - Natural Gas			010100	301A
- - Electricity Plant Coal			010100	102A
- - Straw			010100	117A
- - Wood Chips			010100	111A
- - Wood Pellets			010100	111A
- - Wood Waste			010100	111A
- - Biogas, Landfill			010100	309A
- - Biogas, Sludge			010100	309A

<i>Continued</i>			
- - Biogas, Others		010100	309A
- - Bio Natural Gas		010100	315A
- - Waste, Non-renewable		010100	114A
- - Wastes, Renewable		010100	114A
- Fuels Used for Heat Production			
- - Refinery Gas		010300	308A
- - LPG		010100	303A
- - Naphtha (LVN)		010100	210A
- - Gas-/Diesel Oil		010100	204A
- - Fuel Oil		010100	203A
- - Petroleum Coke		010100	110A
- - Orimulsion		010100	225A
- - Natural Gas		010100	301A
- - Electricity Plant Coal		010100	102A
- - Straw		010100	117A
- - Wood Chips		010100	111A
- - Wood Pellets		010100	111A
- - Wood Waste		010100	111A
- - Biogas, Landfill		010100	309A
- - Biogas, Sludge		010100	309A
- - Biogas, Other		010100	309A
- - Bio Natural Gas		010100	315A
- - Wastes, Non-renewable		010100	114A
- - Wastes, Renewable		010100	114A
- Own Use			
- - Electricity			
- - District Heating			
- Production			
- - Electricity, Gross			
- - District Heating, Net			
Small-Scale CHP Units			
- Fuels Used for Power Production			
- - Gas-/Diesel Oil		010100	204A
- - Fuel Oil		010100	203A
- - Natural Gas		010100	301A
- - Electricity Plant Coal		010100	102A
- - Straw		010100	117A
- - Wood Chips		010100	111A
- - Wood Pellets		010100	111A
- - Wood Waste		010100	111A
- - Biogas, Landfill		010100	309A
- - Biogas, Sludge		010100	309A
- - Biogas, Other		010100	309A
- - Bio Natural Gas		010100	315A
- - Waste, Non-renewable		010100	114A
- - Wastes, Renewable		010100	114A
- Fuels Used for Heat Production			
- - Gas-/Diesel Oil		010100	204A
- - Fuel Oil		010100	203A
- - Natural Gas		010100	301A
- - Electricity Plant Coal		010100	102A
- - Straw		010100	117A
- - Wood Chips		010100	111A
- - Wood Pellets		010100	111A
- - Wood Waste		010100	111A
- - Biogas, Landfill		010100	309A
- - Biogas, Sludge		010100	309A
- - Biogas, Other		010100	309A
- - Bio Natural Gas		010100	315A
- - Wastes, Non-renewable		010100	114A
- - Wastes, Renewable		010100	114A
- Own Use			
- - Electricity			
- - District Heating			
- Production			
- - Electricity, Gross			
- - District Heating, Net			
Wind Turbines			
- Used for Power Production			
- - Wind Power			
- Gross Production			
- - Electricity			

<i>Continued</i>			
Hydro Power Units			
- Used for Power Production			
- - Hydro Power			
- Gross Production			
- - Electricity			
District Heating Units			
- Fuels Used for Heat Production			
- - Refinery Gas		010300	308A
- - LPG		010200	303A
- - Gas-/Diesel Oil		010200	204A
- - Fuel Oil		010200	203A
- - Waste Oil		010200	203A
- - Petroleum Coke		010200	110A
- - Natural Gas		010200	301A
- - Electricity Plant Coal		010200	102A
- - Coal		010200	102A
- - Solar Energy			
- - Geothermal Energy			
- - Straw		010200	117A
- - Wood Chips		010200	111A
- - Wood Pellets		010200	111A
- - Wood Waste		010200	111A
- - Biogas, Landfill		010200	309A
- - Biogas, Sludge		010200	309A
- - Biogas, Other		010200	309A
- - Bio Natural Gas		010200	315A
- - Wastes, Non-renewable		010200	114A
- - Wastes, Renewable		010200	114A
- - Bio Oil		010200	215A
- - Electricity for Heat Pumps			
- Own Use			
- - District Heating			
- Net Production			
- - District Heating			
Auto producers, Electricity Only			
- Fuels Used for Power Production			
- - Natural Gas		030100	301A
- - Solar Energy			
- - Biogas, Landfill		030100	309A
- - Biogas, Sewage Sludge		030100	309A
- - Biogas, Other		030100	309A
- - Bio Natural Gas		030100	315A
- Gross Production			
- - Electricity			
Auto producers, CHP Units			
- Fuels Used for Power Production			
- - Refinery Gas		010300	308A
- - Gas-/Diesel Oil		030100	204A
- - Fuel Oil		030100	203A
- - Waste Oil		030100	203A
- - Natural Gas		030100	301A
- - Coal		030100	102A
- - Straw		030100	117A
- - Wood Chips		030100	111A
- - Wood Pellets		030100	111A
- - Wood Waste		030100	111A
- - Biogas, Landfill		030100	309A
- - Biogas, Sludge		030100	309A
- - Biogas, Other		030100	309A
- - Bio Natural Gas		030100	315A
- - Bio Oil		030100	215A
- - Wastes, Non-renewable		010100	114A
- - Wastes, Renewable		010100	114A
- Fuels Used for Heat Production			
- - Refinery Gas		010300	308A
- - Gas-/Diesel Oil		030100	204A
- - Fuel Oil		030100	203A
- - Waste Oil		030100	203A
- - Natural Gas		030100	301A
- - Coal		030100	102A
- - Wood Chips		030100	111A
- - Wood Waste		030100	111A

<i>Continued</i>			
- - Biogas, Landfill			030100 309A
- - Biogas, Sludge			030100 309A
- - Biogas, Other			030100 309A
- - Bio Natural Gas			030100 315A
- - Wastes, Non-renewable			010100 114A
- - Wastes, Renewable			010100 114A
- Production			
- - Electricity, Gross			
- - District Heating, Net			
Auto producers, Heat Only			
- Fuels Used for Heat Production			
- - Gas-/Diesel Oil			030100 204A
- - Fuel Oil			030100 203A
- - Waste Oil			030100 203A
- - Natural Gas			030100 301A
- - Straw			030100 117A
- - Wood Chips			030100 111A
- - Wood Pellets			030100 111A
- - Wood Waste			030100 111A
- - Biogas, Landfill			030100 309A
- - Biogas, Sludge			030100 309A
- - Biogas, Other			030100 309A
- - Bio Natural Gas			030100 315A
- - Wastes, Non-renewable			010200 114A
- - Wastes, Renewable			010200 114A
- - Heat Pumps			
- Net Production			
- - District Heating			
Gas Works Gas Units		030106	301A
- Fuels Used for Gas Works Gas			
- - Refinery Gas			
- - LPG			
- - Naphtha (LVN)			
- - Gas-/Diesel Oil			
- - Natural Gas			
- - Hard Coal			
- Production			
- - Gas Works Gas			
- - Coke			
Distribution Losses			
- Distribution Losses etc.			
- - Natural Gas			
- - Electricity			
- - District Heating			
- - Gas Works Gas			
Consumption Sector			
- Non-energy Use			
- - White Spirit			
- - Lubricants			
- - Bitumen			
Transport			
Military Transport			
- Aviation Gasoline	Transport	209A	
- Motor Gasoline	Transport	208A	
- JP4	Transport	207A	
- JP1	Transport	207A	
- Gas-/Diesel Oil	Transport	205A	
Road			
- LPG	Transport	303A	
- Motor Gasoline	Transport	208A	
- Other Kerosene	020200	206A	
- Gas-/Diesel Oil	Transport	205A	
- Fuel Oil	Transport	203A	
- Natural gas	Transport	301A	
- Bio Natural Gas	Transport	315A	
- Bioethanol	Transport	223A	
- Biodiesel	Transport	215A	
Rail			
- Motor Gasoline	Transport	208A	
- Other Kerosene	Transport	206A	
- Gas-/Diesel Oil	Transport	205A	

<i>Continued</i>			
- Electricity			
Domestic Sea Transport			
- LPG	Transport	303A	
- Other Kerosene	Transport	206A	
- Gas-/Diesel Oil	Transport	205A	
- Fuel Oil	Transport	203A	
Domestic Aviation			
- LPG	Transport	303A	
- Aviation Gasoline	Transport	209A	
- Motor Gasoline	Transport	208A	
- Other Kerosene	020100	206A	
- JP1	Transport	207A	
International Aviation			
- Aviation Gasoline	Transport	209A	
- JP1	Transport	207A	
Agriculture and Forestry and Horticulture			
- LPG	Transport	303A	
- Motor Gasoline	Transport	208A	
- Other Kerosene	020300	206A	
- Gas-/Diesel Oil	Transport	205A	
- Fuel Oil	020300	203A	
- Petroleum Coke	020300	110A	
- Natural Gas	020300	301A	
- Coal	020300	102A	
- Brown Coal Briquettes	020300	106A	
- Straw	020300	117A	
- Wood Chips	020300	111A	
- Wood Waste	020300	111A	
- Biogas, Other	020300	309A	
- Bio Natural Gas	020300	315A	
- Heat Pumps			
- Electricity			
- District Heating			
Fishing			
- LPG	Transport	303A	
- Motor Gasoline	Transport	208A	
- Other Kerosene	Transport	206A	
- Gas-/Diesel Oil	Transport	205A	
- Fuel Oil	Transport	203A	
Manufacturing Industry			
- Refinery Gas	030100	308A	
- LPG	Transport	303A	
- Naphtha (LVN)	Transport	210A	
- Motor Gasoline	Transport	208A	
- Other Kerosene	030100	206A	
- Gas-/Diesel Oil	Transport	205A	
- Fuel Oil	030100	203A	
- Waste Oil	030100	203A	
- Petroleum Coke	030100	110A	
- Natural Gas	030100	301A	
- Coal	030100	102A	
- Coke	030100	107A	
- Brown Coal Briquettes	030100	106A	
- Wood Chips	030100	111A	
- Wood Pellets	030100	111A	
- Wood Waste	030100	111A	
- Biogas, Landfill	030100	111A	
- Biogas, Other	030100	309A	
- Bio Natural Gas	030100	315A	
- Wastes, Non-renewable	030100	114A	
- Wastes, Renewable	030100	114A	
- Heat Pumps			
- Electricity			
- District Heating			
- Gas Works Gas	030100	301A	
Construction			
- LPG	031500	303A	
- Motor Gasoline	Transport		
- Other Kerosene	031500	206A	
- Gas-/Diesel Oil	Transport		
- Fuel Oil	031500	203A	
- Natural Gas	031500	301A	

<i>Continued</i>			
- Bio Natural Gas	031500	315A	
- Electricity			
Wholesale			
- LPG	020100	303A	
- Other Kerosene	020100	206A	
- Gas-/Diesel Oil	020100	204A	
- Petroleum Coke	020100	110A	
- Natural Gas	020100	301A	
- Wood Waste	020100	111A	
- Bio Natural Gas	020100	315A	
- Electricity			
- District Heating			
Retail Trade			
- LPG	020100	303A	
- Other Kerosene	020100	206A	
- Gas-/Diesel Oil	020100	204A	
- Fuel Oil	020100	203A	
- Petroleum Coke	020100	110A	
- Natural Gas	020100	301A	
- Electricity			
- District Heating			
Private Service			
- LPG	020100	303A	
- Other Kerosene	020100	206A	
- Gas-/Diesel Oil	020100	204A	
- Fuel Oil	020100	203A	
- Waste Oil	020100	203A	
- Petroleum Coke	020100	110A	
- Natural Gas	020100	301A	
- Wood Chips	020100	111A	
- Wood Waste	020100	111A	
- Biogas, Landfill	020100	309A	
- Biogas, Sludge	020100	309A	
- Biogas, Other	020100	309A	
- Bio Natural Gas	020100	315A	
- Wastes, Non-renewable	020100	114A	
- Wastes, Renewable	020100	114A	
- Electricity			
- District Heating			
- Gas Works Gas	020100	301A	
Public Service			
- LPG	020100	303A	
- Other Kerosene	020100	206A	
- Gas-/Diesel Oil	020100	204A	
- Fuel Oil	020100	203A	
- Petroleum Coke	020100	110A	
- Natural Gas	020100	301A	
- Coal	020100	102A	
- Brown Coal Briquettes	020100	106A	
- Solar Energy			
- Wood Chips	020100	111A	
- Wood Pellets	020100	111A	
- Bio Natural Gas	020100	315A	
- Electricity			
- District Heating			
- Gas Works Gas	020100	301A	
Single Family Houses			
- LPG	020200	303A	
- Motor Gasoline	Transport	208A	
- Other Kerosene	020200	206A	
- Gas-/Diesel Oil	020200	204A	
- Fuel Oil	020200	203A	
- Petroleum Coke	020200	110A	
- Natural Gas	020200	301A	
- Coal	020200	102A	
- Coke	020200	107A	
- Brown Coal Briquettes	020200	106A	
- Solar Energy			
- Straw	020200	117A	
- Firewood	020200	111A	
- Wood Chips	020200	111A	
- Wood Pellets	020200	111A	

<i>Continued</i>		
- Bio Natural Gas	020200	315A
- Biodiesel	020200	215A
- Heat Pumps		
- Electricity		
- District Heating		
- Gas Works Gas	020200	301A
Multi-family Houses		
- LPG	020200	303A
- Other Kerosene	020200	206A
- Gas-/Diesel Oil	020200	204A
- Fuel Oil	020200	203A
- Petroleum Coke	020200	110A
- Natural Gas	020200	301A
- Coal	020200	102A
- Coke	020200	107A
- Brown Coal Briquettes	020200	106A
- Solar Energy		
- Bio Natural Gas	020200	315A
- Electricity		
- District Heating		
- Gas Works Gas	020200	301A

Annex 5 - Assessment of completeness and (potential) sources and sinks of greenhouse gas emissions and removals excluded

GHG inventory

The Danish greenhouse gas emission inventories for 1990-2020 include all sources identified by the 2006 IPCC Guidelines where methodologies and default emission factors exist. Some very minor sources have not been estimated due to lack of methodology, activity data or emission factors, i.e.:

- Direct and indirect CH₄ emissions from agricultural soils;
- N₂O emissions from accidental fires.

In addition to these sources, Denmark reports emissions from the memo items 'Multilateral operations', 'Long-term Storage of C in Waste Disposal Sites', 'Annual Change in Total Long-term C Storage' and 'Annual Change in Total Long-term C Storage in HWP Waste' as not estimated due to lack of data.

KP-LULUCF inventory

The KP-LULUCF inventory is considered complete. Please see Chapter 11 for further documentation.

Annex 6 - Additional information to be considered as part of the annual inventory submission and the supplementary information required under Article 7, paragraph 1, of the Kyoto Protocol or other useful reference information

Tables A6.1 to A6.5 below contain the information publically available in this report. Table A6.6 includes the list of discrepancies identified by the ITL (no discrepancies in this submission).

Table A6.1 Total quantities of Kyoto Protocol units by account type at beginning of reported year.

Account type	Unit type					
	AAUs	ERUs	RMUs	CERs	tCERs	ICERs
Party holding accounts	NO	NO	NO	284 392	NO	NO
Entity holding accounts	NO	NO	NO	3 786 243	NO	NO
Retirement account	NO	NO	NO	NO	NO	NO
Previous period surplus reserve account	NO					
Article 3.3/3.4 net source cancellation accounts	NO	NO	NO	NO		
Non-compliance cancellation account	NO	NO	NO	NO		
Voluntary cancellation account	NO	NO	NO	11 164	NO	NO
Cancellation account for remaining units after carry-over	NO	NO	NO	NO	NO	NO
Article 3.1 ter and quater ambition increase cancellation account	NO					
Article 3.7 ter cancellation account	NO					
tCER cancellation account for expiry					NO	
ICER cancellation account for expiry						NO
ICER cancellation account for reversal of storage						NO
ICER cancellation account for non-submission of certification report						NO
tCER replacement account for expiry	NO	NO	NO	NO	NO	
ICER replacement account for expiry	NO	NO	NO	NO		
ICER replacement account for reversal of storage	NO	NO	NO	NO		NO
ICER replacement account for non-submission of certification report	NO	NO	NO	NO		NO
Total	NO	NO	NO	4 081 799	NO	NO

Table A6.2a Annual internal transactions.

Transaction type	Additions						Subtractions					
	AAUs	ERUs	RMUs	CERs	tCERs	ICERs	AAUs	ERUs	RMUs	CERs	tCERs	ICERs
Art6 issuance and conversion												
Party verified projects		NO					NO		NO			
Independently verified projects		NO					NO		NO			
Art3.3 and 3.4 issuance or cancellation												
3.3 Afforestation reforestation			NO				NO	NO	NO	NO		
3.3 Deforestation			NO				NO	NO	NO	NO		
3.4 Forest management			NO				NO	NO	NO	NO		
3.4 Cropland management			NO				NO	NO	NO	NO		
3.4 Grazing land management			NO				NO	NO	NO	NO		
3.4 Revegetation			NO				NO	NO	NO	NO		
3.4 Wetland drainage and rewetting			NO				NO	NO	NO	NO		
Art 12 afforestation and reforestation												
Replacement of expired tCERs							NO	NO	NO	NO	NO	
Replacement of expired ICERs							NO	NO	NO	NO		
Replacement for reversal of storage							NO	NO	NO	NO		NO
Cancellation for reversal of storage												NO
Replacement for non-submission of certification report							NO	NO	NO	NO		NO
Cancellation for non-submission of certification report												NO
Other cancellation												
Voluntary cancellation							NO	NO	NO	284 392	NO	NO
Article 3.1 ter and quater ambition increase cancellation							NO					
Subtotal		NO	NO				NO	NO	NO	284 392	NO	NO

Table A6.2ab Annual internal transactions.

Transaction type	Retirement					
	AAUs	ERUs	RMUs	CERs	tCERs	ICERs
Retirement	NO	NO	NO	NO	NO	NO
Retirement from PPSR	NO					
Total	NO	NO	NO	NO	NO	NO

Table A6.2b Annual external transactions.

Total transfers and acquisitions	Additions						Subtractions					
	AAUs	ERUs	RMUs	CERs	tCERs	ICERs	AAUs	ERUs	RMUs	CERs	tCERs	ICERs
CDM	NO	NO	NO	4 049 551	NO	NO	NO	NO	NO	NO	NO	NO
EU	NO	NO	NO	42 367	NO	NO	NO	NO	NO	102 367	NO	NO
AU	NO	NO	NO	NO	NO	NO	NO	NO	NO	200 000	NO	NO
CH	NO	NO	NO	NO	NO	NO	NO	NO	NO	5 090 001	NO	NO
Subtotal	NO	NO	NO	4 091 918	NO	NO	NO	NO	NO	5 392 368	NO	NO

Table A6.2c Annual transactions between PPSR accounts.

	AAUs	ERUs	RMUs	CERs	tCERs	ICERs	AAUs	ERUs	RMUs	CERs	tCERs	ICERs
Subtotal	NO	NO	NO	NO	NO	NO	NO	NO	NO	NO	NO	NO

Table A6.2d Share of proceeds transactions under decision 1/CMP.8, paragraph 21 - Adaptation Fund.

	AAUs	ERUs	RMUs	CERs	tCERs	ICERs	AAUs	ERUs	RMUs	CERs	tCERs	ICERs
First international transfers of AAUs	NO						NO					
Issuance of ERU from Party-verified projects		NO						NO				
Issuance of independently verified ERUs		NO						NO				

Table A6.2f Total annual transactions.

	Additions						Subtractions					
	AAUs	ERUs	RMUs	CERs	tCERs	ICERs	AAUs	ERUs	RMUs	CERs	tCERs	ICERs
Total (Sum of sub-totals in table 2a and table 2b)	NO	NO	NO	4 091 918	NO	NO	NO	NO	NO	5 676 760	NO	NO

Table A6.3 Expiry, cancellation and replacement.

Transaction or event type	Requirement to replace or cancel			Replacement						Cancellation					
	tCERs	ICERs	CERs	AAUs	ERUs	RMUs	CERs	tCERs	ICERs	AAUs	ERUs	RMUs	CERs	tCERs	ICERs
Temporary CERs															
Expired in retirement and replacement accounts	NO			NO	NO	NO	NO	NO							
Expired in holding accounts	NO													NO	
Long-term CERs															
Expired in retirement and replacement accounts		NO		NO	NO	NO	NO								
Expired in holding accounts		NO													NO
Subject to reversal of Storage		NO		NO	NO	NO	NO		NO						NO
Subject to non submission of certification Report		NO		NO	NO	NO	NO		NO						NO
Carbon Capture and Storage CERs															
Subject to net reversal of storage			NO							NO	NO	NO	NO		
Subject to non submission of certification report			NO							NO	NO	NO	NO		
Total	NO	NO	NO	NO	NO	NO	NO	NO	NO	NO	NO	NO	NO	NO	NO

Table A6.4 Total quantities of Kyoto Protocol units by account type at end of reported year.

Account type	Unit type					
	AAUs	ERUs	RMUs	CERs	tCERs	ICERs
Party holding accounts	269 377 890	NO	NO	NO	NO	NO
Entity holding accounts	NO	NO	NO	2 485 793	NO	NO
Retirement account	NO	NO	NO	NO	NO	NO
Previous period surplus reserve account	NO					
Article 3.3/3.4 net source cancellation accounts	NO	NO	NO	NO		
Non-compliance cancellation account	NO	NO	NO	NO		
Voluntary cancellation account	NO	NO	NO	295 556	NO	NO
Cancellation account for remaining units after carry-over	NO	NO	NO	NO	NO	NO
Article 3.1 ter and quater ambition increase cancellation account	NO					
Article 3.7 ter cancellation account	NO					
tCER cancellation account for expiry					NO	
ICER cancellation account for expiry						NO
ICER cancellation account for reversal of storage						NO
ICER cancellation account for non-submission of certification report						NO
tCER replacement account for expiry	NO	NO	NO	NO	NO	
ICER replacement account for expiry	NO	NO	NO	NO		
ICER replacement account for reversal of storage	NO	NO	NO	NO		NO
ICER replacement account for non-submission of certification report	NO	NO	NO	NO		NO
Total	269 377 890	NO	NO	2 781 349	NO	NO

Table A6.5(a) Summary information on additions and subtractions.

	Additions					ICERs	Subtractions					
	AAUs	ERUs	RMUs	CERs	tCERs		AAUs	ERUs	RMUs	CERs	tCERs	ICERs
Assigned amount units issued	269 377 890											
Article 3 Paragraph 7 ter cancellations							NO					
Cancellation following increase in ambition							NO					
Cancellation of remaining units after carry over							NO	NO	NO	NO	NO	NO
Non-compliance cancellation							NO	NO	NO	NO		
Carry-over		NO		NO								
Carry-over to PPSR	NO						NO					
Total	269 377 890	NO		NO			NO	NO	NO	NO	NO	NO

Table A6.5(b) Summary information on annual transactions.

	Additions					ICERs	Subtractions					
	AAUs	ERUs	RMUs	CERs	tCERs		AAUs	ERUs	RMUs	CERs	tCERs	ICERs
Year 1 (2013)	NO	NO	NO	NO	NO	NO	NO	NO	NO	NO	NO	NO
Year 2 (2014)	NO	NO	NO	37 361	NO	NO	NO	NO	NO	3 142	NO	NO
Year 3 (2015)	NO	NO	NO	815 943	NO	NO	NO	NO	NO	56 320	NO	NO
Year 4 (2016)	NO	NO	NO	60 795	NO	NO	NO	NO	NO	634 856	NO	NO
Year 5 (2017)	NO	NO	NO	77 456	NO	NO	NO	NO	NO	16 155	NO	NO
Year 6 (2018)	NO	NO	NO	5 456	NO	NO	NO	NO	NO	2 559	NO	NO
Year 7 (2019)	NO	NO	NO	3 381 133	NO	NO	NO	NO	NO	1 199	NO	NO
Year 8 (2020)	NO	NO	NO	3 981 722	NO	NO	NO	NO	NO	3 575 000	NO	NO
Year 2021	NO	NO	NO	4 091 918	NO	NO	NO	NO	NO	5 676 760	NO	NO
Year 2022	NO	NO	NO	NO	NO	NO	NO	NO	NO	NO	NO	NO
Year 2023	NO	NO	NO	NO	NO	NO	NO	NO	NO	NO	NO	NO
Total	NO	NO	NO	12 451 784	NO	NO	NO	NO	NO	9 965 991	NO	NO

Table A6.5(c) Summary information on annual transactions between PPSR accounts.

	Additions						Subtractions						
	AAUs	ERUs	RMUs	CERs	tCERs	ICERs	AAUs	ERUs	RMUs	CERs	tCERs	ICERs	
Year 1 (2013)	NO						NO						
Year 2 (2014)	NO						NO						
Year 3 (2015)	NO						NO						
Year 4 (2016)	NO						NO						
Year 5 (2017)	NO						NO						
Year 6 (2018)	NO						NO						
Year 7 (2019)	NO						NO						
Year 8 (2020)	NO						NO						
Year 2021	NO						NO						
Year 2022	NO						NO						
Year 2023	NO						NO						
Total	NO						NO						

Table A6.5(d) Summary information on expiry, cancellation and replacement.

	Requirement to replace or cancel			Replacement						Cancellation					
	tCERs	ICERs	CERs	AAUs	ERUs	RMUs	CERs	tCERs	ICERs	AAUs	ERUs	RMUs	CERs	tCERs	ICERs
Year 1 (2013)	NO	NO	NO	NO	NO	NO	NO	NO	NO	NO	NO	NO	NO	NO	NO
Year 2 (2014)	NO	NO	NO	NO	NO	NO	NO	NO	NO	NO	NO	NO	NO	NO	NO
Year 3 (2015)	NO	NO	NO	NO	NO	NO	NO	NO	NO	NO	NO	NO	NO	NO	NO
Year 4 (2016)	NO	NO	NO	NO	NO	NO	NO	NO	NO	NO	NO	NO	NO	NO	NO
Year 5 (2017)	NO	NO	NO	NO	NO	NO	NO	NO	NO	NO	NO	NO	NO	NO	NO
Year 6 (2018)	NO	NO	NO	NO	NO	NO	NO	NO	NO	NO	NO	NO	NO	NO	NO
Year 7 (2019)	NO	NO	NO	NO	NO	NO	NO	NO	NO	NO	NO	NO	NO	NO	NO
Year 8 (2020)	NO	NO	NO	NO	NO	NO	NO	NO	NO	NO	NO	NO	NO	NO	NO
Year 2021	NO	NO	NO	NO	NO	NO	NO	NO	NO	NO	NO	NO	NO	NO	NO
Year 2022	NO	NO	NO	NO	NO	NO	NO	NO	NO	NO	NO	NO	NO	NO	NO
Year 2023	NO	NO	NO	NO	NO	NO	NO	NO	NO	NO	NO	NO	NO	NO	NO
Total	NO	NO	NO	NO	NO	NO	NO	NO	NO	NO	NO	NO	NO	NO	NO

Table A6.5(e) Summary information on retirement.

Year	Retirement – Unit type					
	AAUs	ERUs	RMUs	CERs	tCERs	ICERs
Year 1 (2013)	NO	NO	NO	NO	NO	NO
Year 2 (2014)	NO	NO	NO	NO	NO	NO
Year 3 (2015)	NO	NO	NO	NO	NO	NO
Year 4 (2016)	NO	NO	NO	NO	NO	NO
Year 5 (2017)	NO	NO	NO	NO	NO	NO
Year 6 (2018)	NO	NO	NO	NO	NO	NO
Year 7 (2019)	NO	NO	NO	NO	NO	NO
Year 8 (2020)	NO	NO	NO	NO	NO	NO
Year 2021	NO	NO	NO	NO	NO	NO
Year 2022	NO	NO	NO	NO	NO	NO
Year 2023	NO	NO	NO	NO	NO	NO

Annex 7 - Information related to the greenhouse gas inventory for the Faroe Islands

Introduction

This report covers the Faroese part of the National Inventory Report for the Kingdom of Denmark.

The report is made by Umhvørvisstovan, the Faroese Environment Agency (FEA) www.us.fo.

Background information on greenhouse gas inventories and climate change

Each year the Faroe Islands is obligated to report its emission of greenhouse gases (GHG), according to the requirements of the United Nations Framework Convention on Climate Change (UNFCCC). The Kingdom of Denmark (which includes Denmark, Greenland and the Faroe Islands as geographical areas) has signed the UNFCCC. The Faroese emission figures are part of the emission total for the Kingdom of Denmark.

When Denmark ratified the Kyoto Protocol, it was with territorial reservation for the Faroe Islands. Since the reservation has not been lifted, the requirements for reporting are only those related to the Convention.

The first emission inventories for the Faroe Islands were made using an average method based upon the total use of fossil fuels in the Faroe Islands and consequently the inventories have only included total estimates of CO₂ emissions. Later, the inventories were done according to IPCC guidelines. Since 2008, the FEA has yearly reported GHG emissions to Danish Centre for Environment and Energy (DCE), Dep. of Environmental Science (ENVS), Aarhus University.

The GHGs reported are:

- Carbon dioxide CO₂
- Methane CH₄
- Nitrous Oxide N₂O
- Hydrofluorocarbons HFCs
- Perfluorocarbons PFCs
- Sulphur hexafluoride SF₆
- Nitrogen trifluoride NF₃

A description of the institutional arrangement for inventory preparation

FEA, an agency under the Ministry of Environment, Industry and Trade (www.uvmr.fo), is responsible for the annual preparation and submission to the UNFCCC of the Faroe Islands' contribution to the Kingdom of Denmark's National Inventory Report and the GHG inventories in the Common Reporting Format in accordance with the UNFCCC Guidelines. The inventory is done with guidance from and in co-operation with DCE.

The work concerning the annual greenhouse gas emission inventory is carried out in co-operation with other Faroese ministries, research institutes, organisations and companies:

- *Statistics Faroe Islands (Ministry of Finance)* www.hagstova.fo

Annual statistics on liquid fuel sale, fuel usage for electricity and heat production, and statistics on livestock (sheep and cows). Fish export. Population.

- *Búnaðarstovan (Agricultural Agency of the Faroe Islands)* www.bst.fo
Dato on usage of fertilizers, number of sheep, estimations and calculations related to emissions form Agriculture
- *Landsverk* – the road authority. www.landsverk.fo.
Data on the vehicle stock and other related data
- *Municipal Waste Plants* www.irf.fo
Data on amount of incinerated and deponized waste.
- *Electricity producing company* www.sev.fo
Data on import of F-gases (SF₆).
- *Airline Company* www.atlantic.fo
Data for fuel bunkers for domestic flights and international flights to and from the Faroe Islands.
- *Refrigeration and other gas sale companies*
Data on import of F-gases (HFCs) and N₂O.
- *Oil companies – license holders*
Data on use of fuel oil in connection with exploration (deep water) drilling in Faroese territorial waters.

In January 2010, DCE and FEA made a formal agreement about data delivery.

Brief description of the process of inventory preparation. Data collection and processing, data storage and archiving

Statistic Faroe Islands collects and stores a major part of the activity data for the inventory, e.g. fuel sale and fuel usage by combustion plants, as well as a number of livestock (sheep and cows). Each year, FEA receives new activity data for fuel sale and fuel usage and other data for the previous year. An increasing part of the data is accessible on the homepage of Statistics Faroe Islands.

Other activity data are delivered by plants owned by municipalities or private companies.

After receiving the data, the material is placed on servers at FEA. The servers are subject to routine backup services. Material that has been backed up is archived safely. All collected data is also archived in the electronic journal of the agency.

The emission factors are yearly received from DCE Denmark, sent by email to the FEA as Excel files. In addition to copying the factors to spread sheet files, the e-mails are archived in the electronic journal.

Since the 2008 submission, all subsequent submissions have been reported in the Common Reporting Format of UNFCCC (CRF). The new format has meant improvements, higher data security and limited the potential for errors in the reporting.

Brief general description of methodologies and data sources used

The GHG inventory for the Faroe Islands includes the following sectors:

- Energy (CRF sector 1)
- Industrial Processes and Product Use (CRF sector 2)
- Agriculture (CRF sector 3)

- LULUCF (CFR sector 4)
- Waste (CRF sector 5)

The applied methodologies follow the IPCC Guidelines. In some cases, the IPCC tier 1 methodologies have been used and in other a combination of tier 2 and tier 3 methodologies have been used.

The methods and the emission factors used in the inventory are shown in Table 1 (emission factors for CO₂, CH₄ and N₂O) and in Table 2 (emission factors for HFCs and SF₆). A brief general description of methodologies is included below for the different sectors.

Table 1 Methods applied, and emission factors used for calculating CO₂, CH₄ and N₂O emissions.

GHG CATEGORIES	CO ₂		CH ₄		N ₂ O	
	Method applied	Emission factor	Method applied	Emission factor	Method applied	Emission factor
1. Energy						
A. Fuel Combustion	T1	CS	T1	CS	T1	CS
1. Energy Industries	T1	CS	T1	CS	T1	CS
2. Manufacturing Industries and Construction	T1	CS	T1	CS	T1	CS
3. Transport	T1, T2	CS	T1, T3	CS, OTH	T1, T3	CS, OTH
4. Other Sectors	T1	CS	T1	CS	T1	CS
2. Industrial Processes and Product Use						
D. Non-energy products from fuels and solvent use	T1	D				
G. Other product manufacture and use					T1	D
3. Agriculture						
A. Enteric Fermentation			T1	D		
B. Manure Management			T1	D	T1	D
D. Agricultural Soils						
4. Land use, land-use change and forestry					T2	D
A. Forest land	T1, T2	CS, D				
B. Cropland						
C. Grassland	T1	D	T1	CS		
D. Wetlands						
E. Settlements	T1	D				
F. Other land						
G. Harvested wood products						
H. Other						
5. Waste						
A. Solid waste disposal			T2	D		
D. Wastewater treatment and discharge			T1	D	T1	D

Table 2 Methods and Emission factors used for calculating HFCs and SF₆ emissions in the Industrial Processes and Product Use sector.

GHG CATEGORIES	HFCs		SF ₆	
	Method applied	Emission factor	Method applied	Emission factor
2. Industrial Processes and Product Use				
F. Product Uses as Substitutes of ODS	T1	D	T1	D

Energy sector

All emissions in the Energy sector are from Fuel combustion (1.A.A), and in these categories:

- 1.A.1 Energy Industries

- 1.A.1.a Public Electricity and Heat Production (incl. Waste incineration)
- 1.A.1.c Manufacture of Solid Fuels and Other Energy Industries
- 1.A.2 Manufacturing Industries and Construction
 - 1.A.2.a Iron and Steel
 - 1.A.2.b Non-Ferrous Metals
 - 1.A.2.c Chemicals
 - 1.A.2.d Pulp, Paper and Print
 - 1.A.2.e Food Processing, Beverages and Tobacco
 - 1.A.2.f Non-metallic Minerals
 - 1.A.2.g v Construction
 - 1.A.2.g viii Other
- 1.A.3 Transport
 - 1.A.3.a Domestic Aviation
 - 1.A.3.b Road Transportation
 - 1.A.3.b.i Cars
 - 1.A.3.b.ii Light duty trucks
 - 1.A.3.b.iii Heavy duty trucks
 - 1.A.3.b.iv Motorcycles
 - 1.A.3.d Domestic Navigation
- 1.A.4 Other Sectors
 - 1.A.4.a Commercial/Institutional
 - 1.A.4.b Residential
 - 1.A.4.c Agriculture/Forestry/Fishing
 - 1.A.4.c.iii Fishing

Statistics Faroe Islands provides the information on fuel sales by fuel type (in m³) and divided into eight main groups (original titles: Fishing vessels, Other ships, Transportation, Industry, Trading and Service, Residential and Communities, Institutions and Public Power), each group again divided into sub-groups.

The fuel data delivered by Statistics Faroe Islands originate from several sources. The main data sources are the two main oil companies in the Faroe Islands. Fuel data not included in sales information from the oil companies are delivered by the industry to FEA.

Since the delivered data on fuel sale are not fully arranged according to IPCC guidelines, the FEA rearranges the data to comply with the guidelines.

Emission factors

Emissions from fuel combustion can be divided into two main sources: stationary and mobile combustion. Stationary combustion is fuel combustion related to e.g. industry on land, house heating and oil exploration. Mobile combustion includes the combustion in engines used for propulsion in the various modes of transport such as road transport, marine activities, and aviation. The emission factors used for stationary, transport, waste and aviation are country specific and provided by DCE. All emissions factors used in the inventory are found in Annex 1.

Emissions are calculated by multiplying fuel consumption data with an emission factor (e.g., in tonnes emission per GJ fuel).

Public Electricity and Heat Production (1A1a)

The activity data used for calculations of emissions of GHG from Public Electricity and Heat Production are the consumption of residual oil and diesel oil at electricity producing plants on the Faroe Islands. The emission factors are calculated and delivered by DCE, see

Table 23 in Annex 1.a.

Manufacture of Solid Fuels and Other Energy Industries (1A1c)

This category only covers the emissions of GHG from activities related to exploration drilling in Faroese territory. The operators deliver the activity data (usage of diesel on the rigs). The emission factors are calculated and delivered by DCE, see

Table 23 in Annex 1.a.

Manufacturing Industries and Construction (1A2)

Statistics Faroe Islands deliver the activity data for oil usage. The emission factors are calculated and delivered by DCE, see

Table 23 in Annex 1.a.

Domestic Aviation (1A3a)

The Faroese airline company, Atlantic Airways, www.atlantic.fo delivers data for jet fuel bunkered in the Faroe Islands. Since the Faroe Islands has accepted the United Nations Framework Convention on Climate Change as a part of the Kingdom of Denmark, aviation between Denmark and the Faroe Islands is to be reported as Domestic Aviation. The jet fuel data is thus divided by destination: flights to destinations inside the Kingdom of Denmark, i.e., Denmark and Greenland (Domestic Aviation), and outside the Danish Kingdom, e.g., Iceland, Norway, and Great Britain (International Aviation). Fuel refuelled outside the Faroe Islands is not included in the Faroese inventory. The emission factors for aviation are calculated and delivered by DCE, see Table 25 in Annex 1.b.

Road Transportation (1A3b)

The activity data for road transportation is data for sale of gasoline and diesel to all types of vehicles at all filling stations in the Faroe Islands. The data is delivered by the Statistics Faroe Islands. The emission factors for road traffic are calculated and delivered by DCE taking into account vehicle stock data from the Faroe Islands combined with assumptions on size and age distribution for each vehicle class derived from the Danish inventory. The Danish results are modified for Faroese traffic conditions such as other gross vehicle weights for heavy-duty vehicles and no highway driving conditions. The emissions factors are also modified because biofuel is not used in the Faroe Islands, unlike in Denmark. The emission factors are shown in Table 26 in Annex 1.b.

Domestic Navigation (1A3d)

Statistics Faroe Islands deliver the activity data for oil used in navigation. The emission factors are calculated and delivered by DCE, see Table 27 in Annex 1.b.

Other sectors (1A4)

The activity data for oil usage used to calculate the GHG emissions from the Commercial/Institutional (1A4a) and Residential (1A4b) sectors are delivered by Statistics Faroe Islands. The emission factors calculated and delivered by DCE are found in

Table 23 in Annex 1.a.

Fishing (1A4ciii)

Statistics Faroe Islands deliver the activity data (sale of oil to fishing vessels). A private oil company delivers data on oil bunkered in the Faroe Island onto foreign fishing vessels. This data is not a part of the official statistic in Statistics of the Faroe Islands. The emission factors are calculated and delivered by DCE and are found in Table 27 in Annex 1.b.

The inventory includes all oil bunkered on Faroese territory, though excluding oil bunkered by international companies, i.e., from a foreign supplier to a foreign customer at open sea or on near-coast sites.

Industrial Processes and Product Use

Emissions from Industrial processes and Product Use are allocated to these categories:

- 2.D Non-energy products from fuels and solvent use
 - 2.D.1 Lubricant use
 - 2.D.2 Paraffin wax use
- 2.F Product Uses as Substitutes for ODS
 - 2.F.1 Refrigeration and Air conditioning
- 2.G Other Product Manufacture and Use
 - 2.G.1 Electrical Equipment
 - 2.G.3a Medical applications

The inventory follows the principles in the IPCC Guidelines with a Tier 1 methodology. The emissions factors are IPCC default.

The activity data for lubricant use, wax use come from Statistics Faroe Islands. The activity data for N₂O comes from the importer.

The activity data on the consumption (import) of HFCs and SF₆ origin from FEA surveys that have been conducted annually since 2003. An estimate of the consumption has been done for the years 1990-2002.

Solvent and other product use

Since no data are available, emissions from solvent and other product use are not calculated.

Agriculture

GHG emissions from agriculture are calculated for following categories:

- 3.1 Livestock
 - 3.A Enteric Fermentation
 - 3.B Manure Management
- 3.D Agricultural Soils
 - 3.D.1 Direct N₂O Emissions from Managed Soils
 - 3.D.2 Indirect N₂O Emission from Managed Soils

The inventory follows the principles in the IPCC Guidelines and the IPCC Good Practice Guidance. Tier 1 method is always used. All emission factors used for agriculture are IPCC standard values. The emissions are calculated

with support from DCE. Activity data is accessible on the homepage of Statistics Faroe Islands (number of cows and sheep) and received from other sources.

Waste

GHG emissions from Waste are calculated for following categories:

- 5.A Solid Waste Disposal
 - 5.A.1 Managed Waste Disposal Sites
 - 5.A.2 Unmanaged Waste Disposal Sites
- 5.D Wastewater treatment and discharge

Waste incineration is done with energy recovery as such the emissions are allocated to the Energy sector. Emission factors relative to emissions of CO₂, N₂O and CH₄ from waste incineration in 1990-2020 are listed in able 24 in Annex 1.a. Heating values for waste incineration are listed in Table 3.

Table 3 Heating values (GJ/t) for waste.

Year	Heating values
1990-91	8,2
1992	9,0
1993-94	9,4
1995	10,0
1996-2012	10,5
2013-2020	10,6

Brief description of key categories

No country-specific key category analysis has been carried out.

Information on QA/QC plan including verification and treatment of confidential issues where relevant

Several measures are in place to ensure the quality of the greenhouse gas inventory for the Faroe Islands.

The general QC activities include:

- Check that data from Statistics Faroe Islands and other data deliverers are correctly transferred to emissions spreadsheets.
- Check that data are correctly transferred between data processing steps, e.g., it is ensured that the data are imported correctly from the emission spread sheets/databases to the CRF Reporter.
- The time series are analysed. Any large fluctuations are investigated and explained/corrected.
- The completeness of the inventory is checked utilising the completeness checker incorporated in the CRF Reporter.

These types of QC checks are recommended as Tier 1 QC checks in the IPCC Guidelines (IPCC, 2006).

No confidential issues are relevant.

General uncertainty evaluation, including data on the overall uncertainty for the inventory totals

Uncertainty evaluation has not been made for the Faroese inventory.

General assessment of the completeness

In general, the inventory is complete for what is considered the significant sources. Since last delivery, the inventory has been improved and does now also include the LULUCF sectors as well as some improvements have been made, mostly in the IPPC, Agriculture and Waste sector.

References

Lastein, L. & Winther, M. 2003: Emissions of greenhouse gases and long-range transboundary air pollutants in the Faroe Islands 1990-2001. National Environmental Research Institute, Denmark. 62 p. NERI Technical Report no. 477. Available at:
http://www2.dmu.dk/1_viden/2_Publikationer/3_fagrapporter/rapporter/FR477.pdf

Winther, M. 2001: 1998 Fuel Use and Emissions for Danish IFR Flights. Environmental Project no. 628, 2001. 112 pp. Danish EPA. Prepared by the National Environmental Research Institute (NERI), Denmark. Electronic report at homepage of Danish EPA. Available at:
<https://www2.mst.dk/udgiv/publications/2001/87-7944-661-2/pdf/87-7944-662-0.pdf>

Umhvørvisstovan, 2021: Útlát av vakstrarhúsgassi í Føroyum 1990-2020. July 2021. Available at: <https://www.us.fo/Default.aspx?ID=13912>

Trends in Greenhouse Gas Emissions

The trends present in this Chapter cover the emissions from the Faroe Islands.

The whole inventory, including trend tables and emission trend summary tables, can be found on the homepage of EIONET. Available at: https://cdr.eionet.europa.eu/dk/Air_Emission_Inventories/Submission_UNFCCC/

Description and interpretation of emission trends for aggregated greenhouse gas emissions

The greenhouse gas emissions are estimated according to the IPCC guidelines and are aggregated into five main sectors: Energy, Industrial Processes and Product Use, Agriculture, Land Use, Land-Use Change and Forestry and Waste. Emissions from waste incineration are allocated to the Energy sector. The main part, 81 %, of the emissions is from the fuel consumption in the energy sector. Figure 1 shows the estimated total greenhouse gas emissions in CO₂ equivalents from 1990 to 2020. The total greenhouse gas emission in CO₂ equivalents has increased by 74.0 % from 1990 to 2020. Comments on the overall trends etc. are given in the sections below.

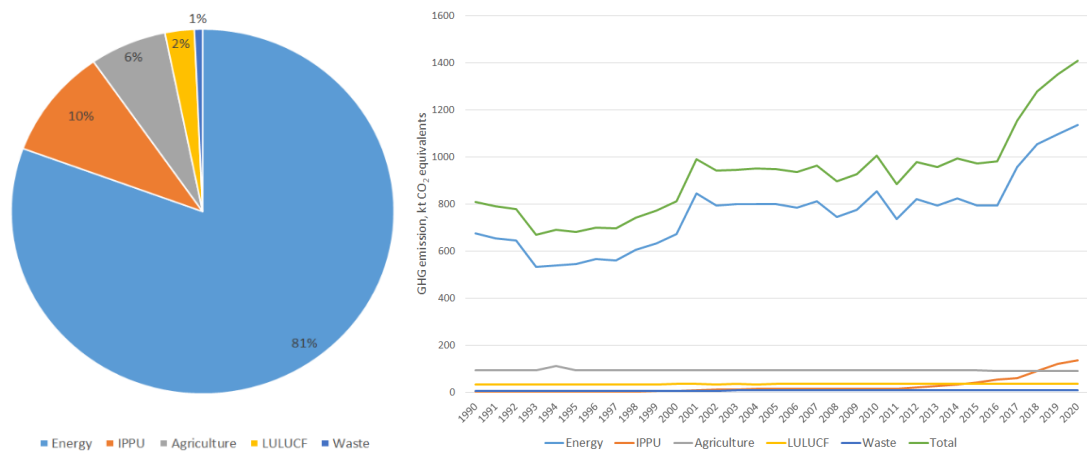

Figure 1 Greenhouse gas emissions in CO₂ equivalents distributed on main sectors for 2020 and time series for 1990 to 2020.

The greenhouse gases include CO₂, CH₄, N₂O, HFCs and SF₆. Figure 2 shows the composition of greenhouse gas emissions (CO₂, N₂O, CH₄ and F-gases) in 2020, calculated in GWP values. CO₂ is the most important greenhouse gas contributing with 83%, followed by F-gases (HFCs and SF₆) with 9.6 %, N₂O with 5.4 % and CH₄ with 2.3 %.

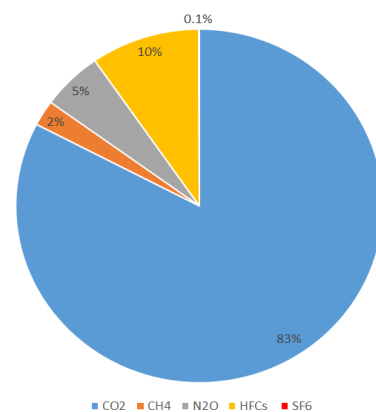

Figure 2 Emissions of GHG in CO₂ equivalents in 2020, distributed on type of gas.

Figure 3 shows the total emissions of greenhouse gases and the emission of CO₂, N₂O, CH₄ and F-gases (in CO₂ equivalents) in the time period 1990-2020. From 1990 to 1993, a decrease is observed, due to an economic crisis in the Faroe Islands, which lasts for 6-8 years. From 2001 to 2007, the emissions were rather stable. In 2008-2011, the emissions from Faroese fishing ship were significantly lower than previous years, especially due to rising oil prices and lower prices on fish. The decrease is concealed by emissions related to new bunkering activity starting in 2009 that has led to a substantial increase in the number of foreign fishing vessels bunkering in the Faroe Island. In general, the total emission of greenhouse gases on the Faroe Islands were relative stable from 2001 until 2016, around and above 800 thousand tonnes of CO₂ equivalents pr. year. A significant and step rise in the emission was seen in 2017 and every year after, increasing the emissions to more than 1.3 million CO₂ equivalents in 2020.

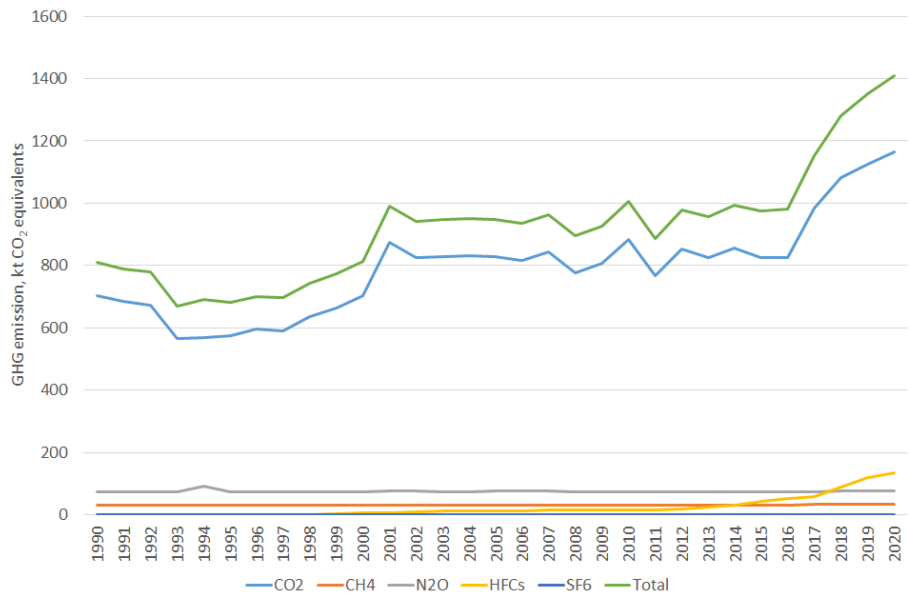

Figure 3 GHG emission by gas in CO₂ equivalents, time series 1990-2020.

Description and interpretation of emission trends by gas

Carbon dioxide

The emission of CO₂ on the Faroe Islands is from fuel consumption only. The trend in the total emission of CO₂ (Figure 4) is nearly identical with the trend of the total emission of GHG in the Faroe Islands (Figure 3) showing the trends in CO₂ emissions in the period from 1990 to 2020. After the economic decline in the 1990's, the emissions rose and were rather constant until 2007. From 2008 to 2011, the effort in the Faroese fishing fleet was significantly lower than previous years, also meaning a significant reduction in oil consumption. The reduction in the emissions for fisheries in 2009 and 2011 is not visible because a new oil bunkering activity (mostly used by foreign fishing vessels) started up in 2009, increasing the emissions. As seen in figure 4, the rise in the total emission in 2017 and 2018 is due to more energy usage on fishing vessels, whereas the rise in 2019 and 2020 is mainly due to increase in use of fuel in fishing vessels and in production of public electricity.

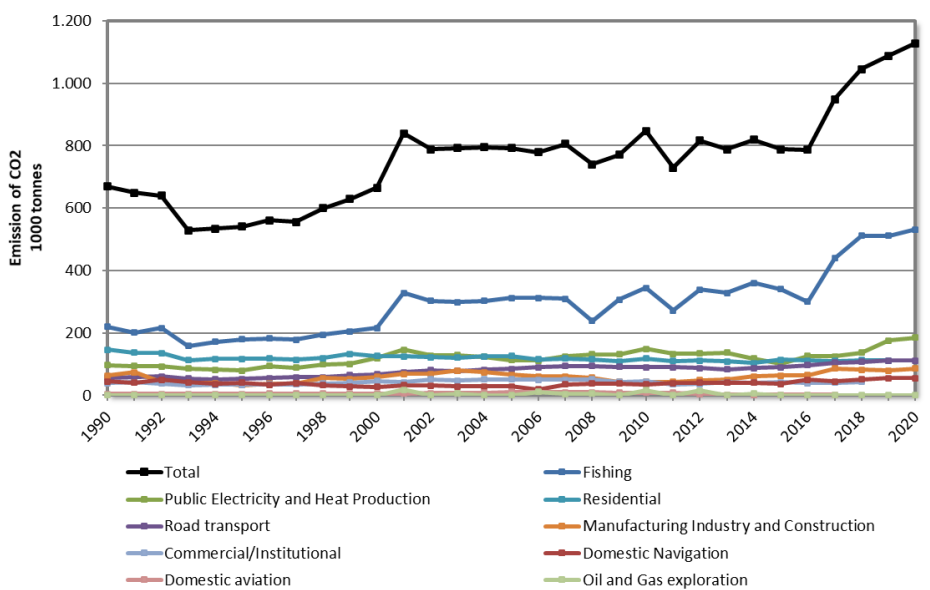

Figure 4 Total CO₂ emissions, by sector, time series for 1990-2020.

Figure 5 shows how the emissions are distributed between categories. In 2020, 41 % of the emissions of CO₂ came from fishing vessels. Public Electricity and Heat Production, Residential and Road Transportation accounted for 14 %, 9 % and 9 % of the total CO₂ emission.

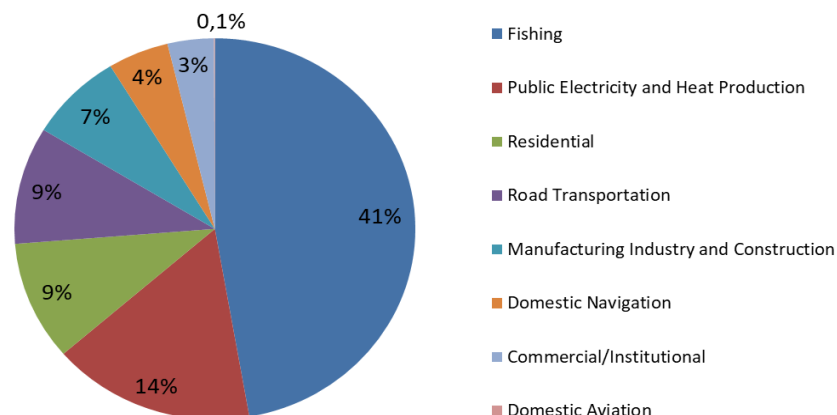

Figure 5 Emissions of CO₂ in the Energy sector, divided in fuel consumption categories, in CO₂ equivalents, 2020.

Nitrous oxide

Figure 6 shows the emissions of nitrous oxide in the Faroe Islands 1990-2020. Almost all of the N₂O emissions are from the Agricultural sector (89 %), i.e. from animals grazing on agricultural soils, but much less from manure management. A smaller contribution comes from energy and wastewater treatment. The peak in 1994 will be further investigated for the next submission. There is an apparent inconsistency in the area of grassland causing the peak in emissions related to crop residues.

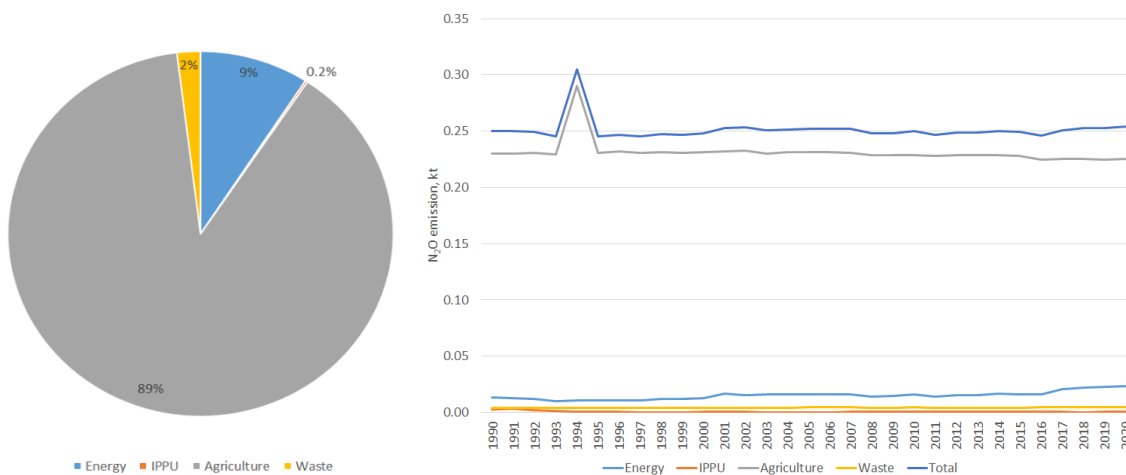

Figure 6 N₂O emissions in tonnes distributed on sector and time series for 1990-2020.

Methane

Figure 7 shows the emissions of methane in the Faroe Islands 1990-2020. Most of the methane emission is from the agriculture sector, especially from enteric fermentation (71 %). With the second most important source being the waste sector (landfills and wastewater treatment) accounting for 25 %. Most of the emission of CH₄ in the energy sector is due to aviation activity.

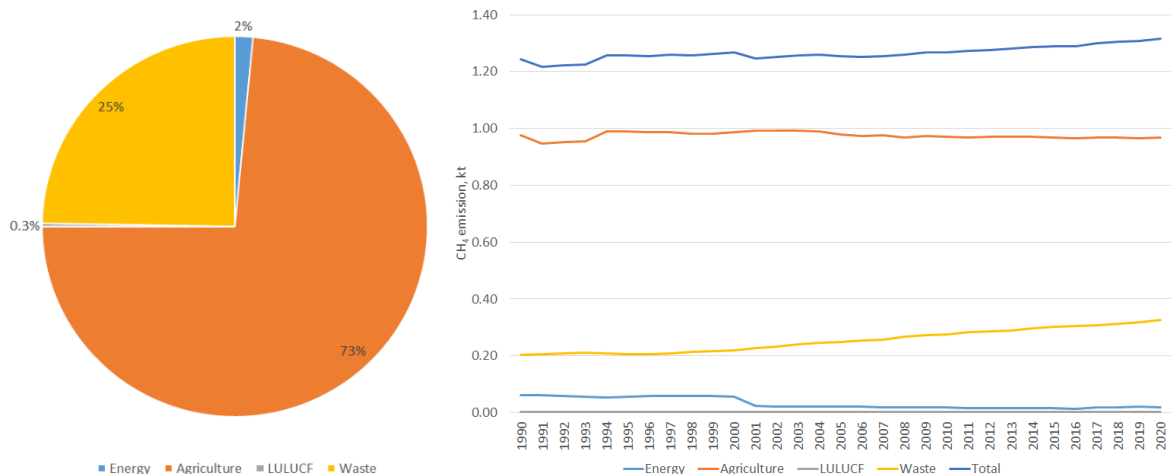

Figure 7 CH₄ emissions in tonnes distributed on sectors and time series for 1990-2020.

HFCs, PFCs, SF₆ and NF₃

Figure 8 shows the emissions of F-gases, HFCs and SF₆ respectively, in the years 1990-2020. Most of the emission is HFCs, used for refrigeration purposes, as substitutes for HCFCs. After the emissions increased in the period 1996-2005, the emissions were rather stable at around 14,000 tonnes of CO₂ equivalents pr. year until 2011. Since then, the emission has increased each year, and in 2020, the emissions of HFC have eight folded since 2012, to in total around 135 kt of CO₂ equivalents. This is due to higher use of HFC-125 and HFC-143a, both components in the HFC-blend HFC-507a, which in recent years has been used as a substitute when phasing out HCFC-22 (ozone depleting freezing agent) on fishing vessels. See also Table 4.

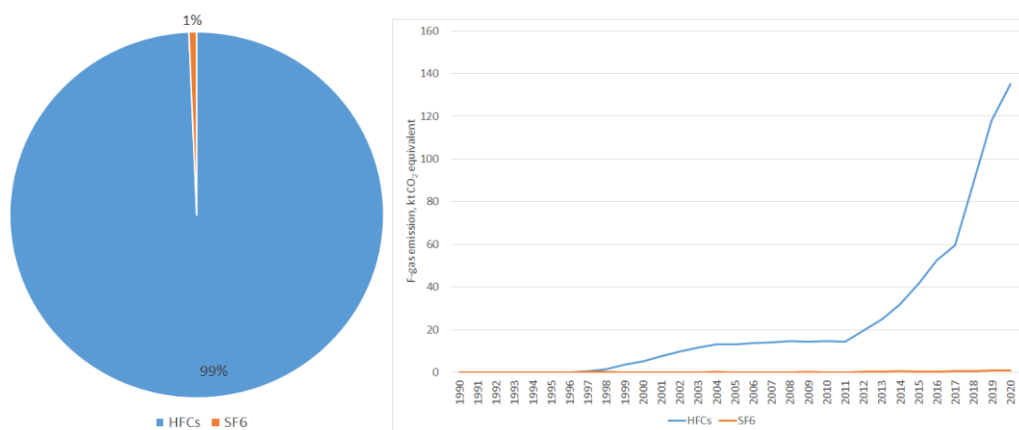

Figure 8 F-gas emissions in CO₂ equivalents, contribution from type of F-gas and time series for 1990-2020.

Neither PFCs nor NF₃ have been in use in the Faroe Islands.

Description and interpretation of emission trends by source

In 2020, 81 % of all GHG emissions were from the Energy sector, including waste incineration. Approximately 10 % were from Industrial Processes and Product Use, and around 6 % from Agriculture, see Figure 9. The remaining emission is from LULUCF and the waste sector.

The fluctuations in the GHG emissions in the Energy sector are decisive for the fluctuations in the total GHG emissions, see Figure 9. The emissions from the Agriculture sector, Industrial processes and Product Use sector, LULUCF sector and the Waste sector are relatively small and constant.

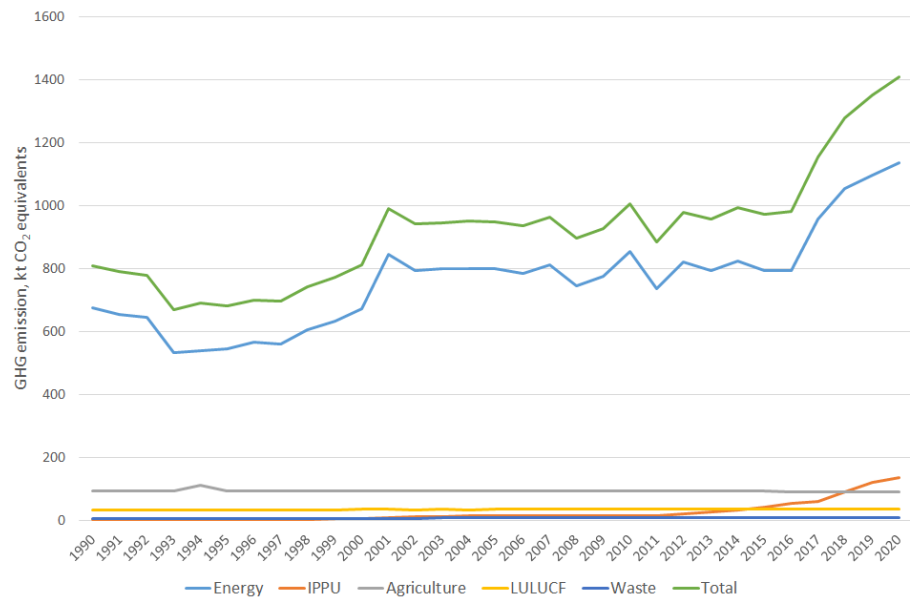

Figure 9 GHG emissions in CO₂ equivalents, main sectors, time series 1990-2020.

Description and interpretation of emission trends for indirect greenhouse gases and SO₂

Emission trends for indirect greenhouse gases and SO₂ have not been made for the Faroe Islands.

Energy (CRF sector 1)

Overview of the sector

Fuel consumption on the Faroe Islands, 1990-2020, can be seen in Figure 10. Most of the fuel is used by fishing vessels.

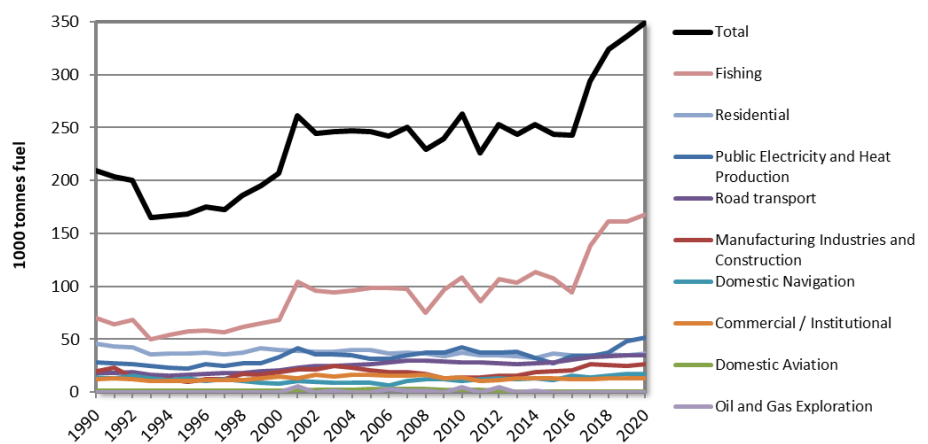

Figure 10 Fuel consumption (tonnes) in the Energy sector, including waste incineration, 1990-2020.

Figure 11 shows the GHG emissions in the Energy sector on the Faroe Islands 1990-2020. The trend is just the same as in Figure 10.

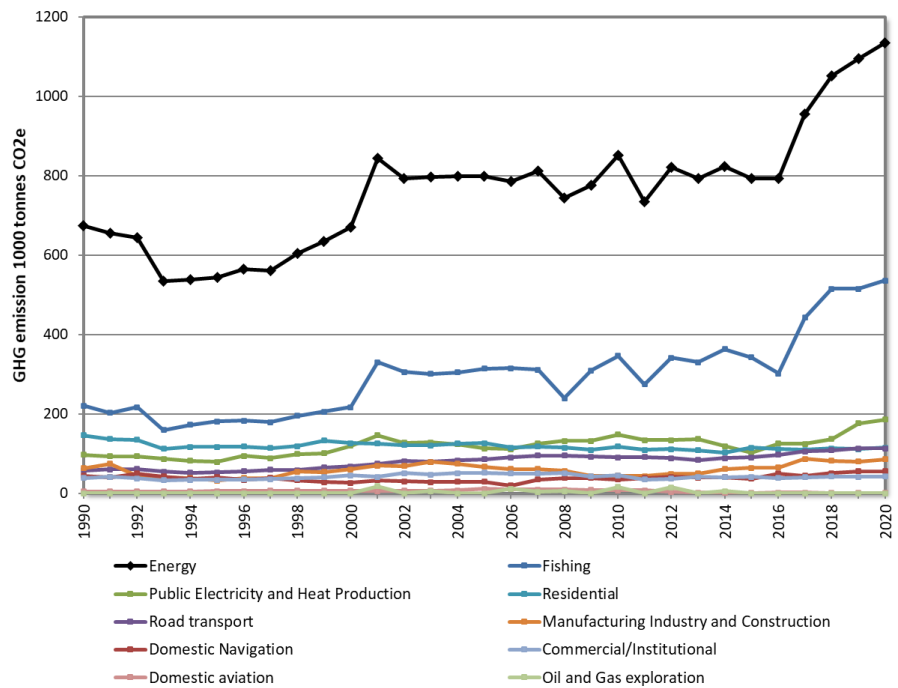

Figure 11 GHG emissions in CO₂ equivalents, categories in the Energy sector, 1990-2020.

Figure 12 shows how the emission of GHG in 2020 was distributed between groups of fuel users. Fishing vessels, Public Electricity and Heat Production, Residential and Road transportation had 41, 14, 9 and 9 %, respectively, of the emissions in the Energy sector in 2020.

Waste Incineration has been included under category 1.A.1.a (Public Electricity and Heat Production), comprising 11 % of the total emissions in the category and 1.5 % of the total emissions in the Faroe Islands in 2020.

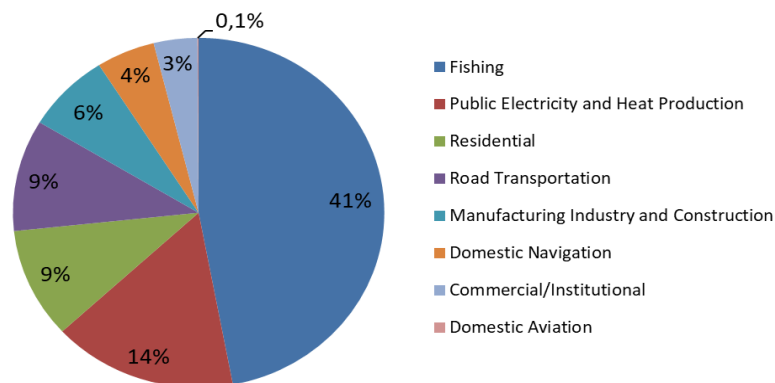

Figure 12 GHG emissions in CO₂ equivalents; Energy sector divided in categories, 2020.

Reference approach

In the 2022 submission, the reference approach was reported for the first time. Further improvements need to be made as it relates to incorporation of data on international bunkers and to investigate the differences between the sectoral and reference approaches.

Fugitive emissions (CRF sector 1B)

Fugitive emissions of GHG gases are estimated to be very limited on the Faroe Islands. These emissions have not been estimated.

Industrial Processes and Product Use (CRF Sector 2)

There is no chemical industry, no metal production, no production of F-gases and no mineral production (other than road paving with asphalt) on the Faroe Islands.

Overview of the sector

The only industrial processes leading to GHG emissions on the Faroe Islands is the use of f-gases and use of lubricants, paraffin wax and N₂O. Of the total emissions in 2020, 9.7 % are emissions related to Industrial Processes and Product Use.

Figure 13 shows the f-gas emissions from Industrial Processes and Product Use sector on the Faroe Islands 1990-2020. The increase in f-gas emissions, starting in 1996, is due to use of HFCs in refrigeration, as substitute for ODS. See also Figure 8.

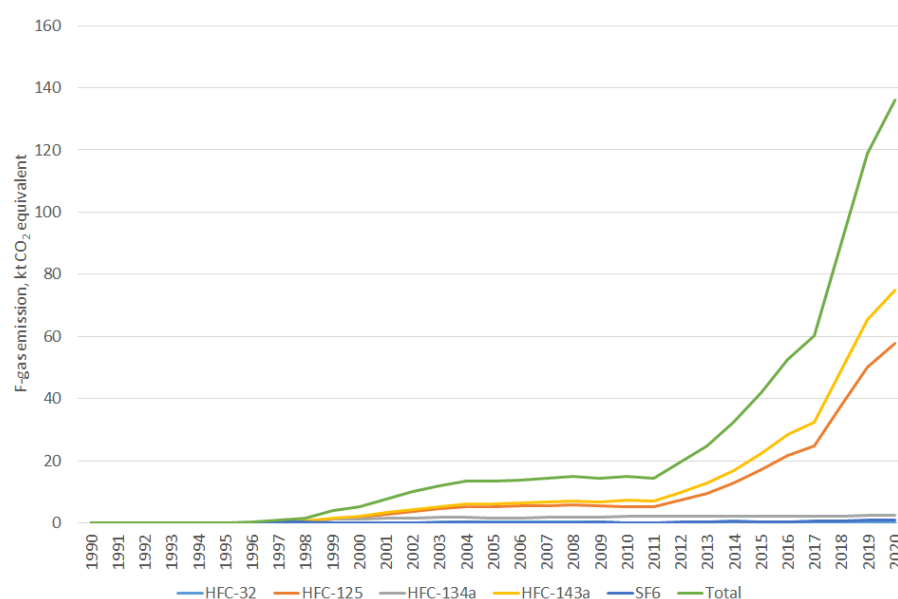

Figure 13 Emissions of f-gases, in CO₂ equivalents, Industrial processes and Product Use, 1990-2020.

Mineral Industry (2A)

There is no mineral production in the Faroe Islands, other than paving roads with asphalt, which does not lead to direct greenhouse gas emissions.

Chemical Industry (2B)

No chemical industry with GHG emission is in the Faroe Islands.

Metal Industry (2C)

No metal production industry is in the Faroe Islands.

Non-energy products from fuels and solvent use (2D)

CO₂ emissions from lubricant use and paraffin wax use have been estimated and reported. The activity data are from Statistics Faroe Islands and the methodologies used are the IPCC tier 1 methodologies. In the calculation is used the IPCC default net calorific values for lubricants and paraffin wax as well as the default carbon content. The IPCC default percentage of carbon oxidised during use (ODU) is 20 % and this value has been used.

Production of Halocarbons and SF₆ (2E)

There is no production of halocarbons and SF₆ in the Faroe Islands.

Product Uses as Substitutes for ODS (2F)

Of the total emissions of f-gases, nearly all (99 %) is HFC gasses used as substitutes for ozone depleting substance HCFC-22, used for refrigeration purposes domestically, commercially and in the industry. Four different types of HFCs are used on the Faroe Islands, mostly in HFC gas blends, such as HFC-507. Time series of the emission (tonnes) of the four different HFC for the years 1990, 2000, 2005, 2010-2020, are seen in Table 4.

The HFC emissions are reported with the following assumptions:

- Domestic refrigeration is use in freezers and refrigerators.
- Commercial refrigeration is use in land-based units.
- Industrial refrigeration is use on ships.
- Mobile air conditioning is use in cars, buses, and trucks.

Table 4 Emissions of HFCs from refrigeration and air conditioning, 1990, 2000, 2005, 2010-2020 (tonnes).

	1990	2000	2005	2010	2011	2012	2013	2014	2015	2016	2017	2018	2019	2020
Domestic refrigeration														
HFC-134a	0,00	0,003	0,007	0,012	0,012	0,012	0,012	0,012	0,011	0,010	0,010	0,009	0,008	0,007
Commercial refrigeration														
HFC-134a	0,00	0,04	0,14	0,15	0,19	0,17	0,19	0,25	0,28	0,26	0,23	0,20	0,23	0,23
HFC-32	0,00	0,09	0,32	0,08	0,08	0,08	0,08	0,07	0,06	0,04	0,03	0,02	0,02	0,03
HFC-125	0,00	0,15	0,51	0,55	0,58	0,68	0,77	0,87	1,00	1,11	1,19	1,23	1,42	1,37
HFC-143a	0,00	0,06	0,19	0,51	0,56	0,67	0,77	0,89	1,04	1,15	1,25	1,32	1,56	1,50
Industrial refrigeration														
HFC-134a	0,00	0,16	0,43	0,35	0,35	0,29	0,30	0,28	0,27	0,25	0,30	0,31	0,38	0,35
HFC-125	0,00	0,34	1,00	0,96	0,87	1,43	1,97	2,77	3,84	5,11	5,91	9,53	12,93	15,11
HFC-143a	0,00	0,40	1,17	1,10	0,99	1,53	2,08	2,85	3,93	5,19	5,98	9,59	13,07	15,26
Mobile Air Conditioning														
HFC-134a	0,00	0,70	0,59	0,94	0,97	1,00	1,02	1,03	1,04	1,04	1,05	1,08	1,08	1,06

Other Product Manufacture and Use (2G)

Figure 14 shows the emissions of SF₆ from Electrical Equipment on the Faroe Islands 1990-2020.

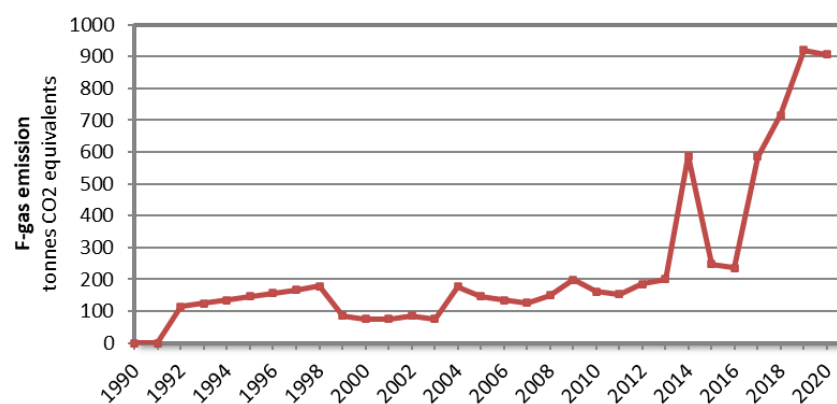

Figure 14 Emission of SF₆, in CO₂ equivalents, time series for Electrical Equipment, 1990-2020.

In 2014, a significant increase was in the actual emission of SF₆. The increase was due to establishment of a new windmill park in Húsahagi, just outside

the capital Tórshavn, owned by SEV, the public electricity company. The high usage in 2017 was due to establishment of a new switchyard “innan Eið”, near Fuglafjørð.

In addition to the SF₆, N₂O emissions are estimated based on the imported amounts. There is no production of N₂O in the Faroe Islands. In accordance with the 2006 IPCC Guidelines, an emission factor of 1 is assumed. All emissions are reported under 2G3a Medical applications as this is considered the main (perhaps only) use.

Uncertainty

Estimations of the uncertainties for emission calculations in the sector Industrial processes and Product Use have not been done.

Agriculture (CRF Sector 3)

6.5 % of the total GHG emissions on the Faroe Islands in 2020 are due to agriculture. The sources are cattle and sheep. The agricultural sector at the Faroe Islands is a relatively small contributor to the total greenhouse gas emission, and thus for years 1990 – 2020 the sector accounts for between 6-16 % of total emission. At the Faroe Islands, only 5-6% of the total area are cultivated and only 1% of Faroese is today full-time farmers. However, it is common at the countryside to keep sheep breeding and cultivate hay. Besides the sheep population, the Faroe Islands also have 1550-2000 cattle.

Figure 15 shows the total emissions from the Agriculture sector. The emissions are very constant. The peak in 1994 will be further investigated for the next submission. There seems to be an inconsistency in the grassland area causing the peak in emissions from crop residues.

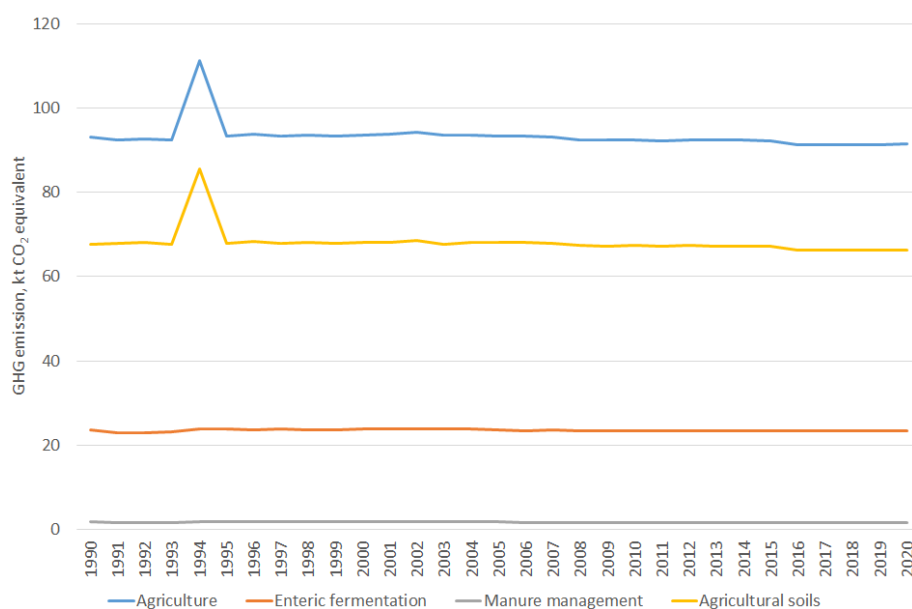

Figure 15 GHG emissions in CO₂ equivalents, in the Agriculture sector, 1990-2020.

Overview

The emission of greenhouse gases from agricultural activities includes:

- CH₄ emission from manure management and enteric fermentation.
- N₂O emission from manure management and agricultural soil (direct and indirect N₂O emission from managed soils).

CH₄ and N₂O emission from the livestock production

Number of animals

Sheep

There are no official requirements for registration of the individual sheep, and there is no slaughterhouse at the Faroes Islands, which is a challenge for estimation of the population. The sheep management is not driven by an intensively production, thus the sheep farmers slaughter their sheep themselves and the products is used by the farmers themselves or their family members, and only a small part of the meat may be sold within the Faroes (Austrheim et al., 2008).

In the FO national emission inventory, the number of mother sheep is estimated to approximately 80,000 mother sheep for all years 1990 – 2020.; approximately 75,000 mother sheep and 5,000 rams. Furthermore, the Agricultural Agency estimated the number of lambs to 52,500 based on the assumption that each mother sheep in average produce 0.7 lamb, see Table 5.

In this year's reporting, lamb as well as rams are not included.

Table 5 Number of sheep in the Faroe Islands.

	Winther	Spring	Summer	Autumn
Ewe/Áseyður/Moderfár	75 000	75 000	75 000	75 000
Rams/Young rams	2 500	2 500	2 500	2 500
Veðrar/veðragjólingar				
Væddere/ Unge væddere				
Lamb in the autumn and sheep that grazes on grass-covered terraces in bird cliffs	2 500	2 500	2 500	2 500
Heystlomb, skoraseyður				
Efterårsfår og får, som græsser på terrasser i fuglebjerge				
Lamb/Lomb/Lam	-	-	52 500	52 500
Inside in sheephouse	2 500	6 000	-	-
Inni í fjósi, seyðahúsi /				
Inde i stald, fårehus				
In the outfield /	77 500	74 00	132 500	132 500
Haga / I udmarken/				
Sheep in total	80 000	80 000	132 500	132 500
Seyður í alt / Får í alt				

Reference: Jens Ivan í Gerðinum, the Agricultural Agency of the Faroe Islands.

Dairy cattle and Non-dairy cattle

The number of dairy cattle and non-dairy cattle is based on data from Statistics of Faroe Islands. The national emission inventory distinguishes between dairy cattle and non-dairy cattle (all other cattle), see Table 6.

Table 6 Number of cattle at the Faroe Islands, 1990-2020.

IPCC code	Livestock category, no. of cattle	1990	1995	2000	2005	2010	2015	2016	2017	2018	2019	2020
3A1	Total cattle	2.070	2.322	2.306	2.135	1.990	1.872	1.826	1.895	1.873	1.801	1837
3A1a	Dairy cattle	1.040	1.206	1.101	1.048	919	1.113	1.116	1.104	1.115	1.116	1148
3A1b	Non-Dairy	1.030	1.116	1.205	1.087	1.071	759	710	791	758	685	689

Reference: Hagstova Føroya, Statistics of Faroe Islands.

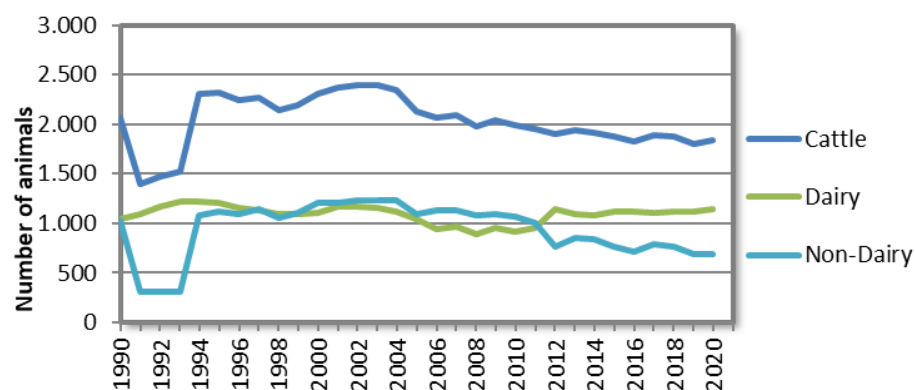

Figure 16 Number of cattle (dairy and non-dairy), time series for 1990-2020.

Figure 16 shows the number of cattle in the Faroe Islands from 1990 to 2020. The number of sheep is around 80,000, which corresponds to the carrying capacity for sheep on the islands. There are no data on the exact number of sheep nor on the number of sheep slaughtered.

CH₄ emission from Enteric Fermentation (CRF Sector 3A)

The calculation of CH₄ production from the animals' digestive process is based on the total gross energy intake (GE) in feed and the CH₄ conversion factor (Y_m), which is the fraction of gross energy in feed converted to CH₄ (see IPCC 2006 calculation equation below).

EQUATION 10.21
CH₄ EMISSION FACTORS FOR ENTERIC FERMENTATION FROM A LIVESTOCK CATEGORY

$$EF = \left[\frac{GE \cdot \left(\frac{Y_m}{100} \right) \cdot 365}{55.65} \right]$$

Where:

EF = emission factor, kg CH₄ head⁻¹ yr⁻¹

GE = gross energy intake, MJ head⁻¹ day⁻¹

Y_m = methane conversion factor, per cent of gross energy in feed converted to methane

The factor 55.65 (MJ/kg CH₄) is the energy content of methane

Table 7 lists the GE factors used in the calculations. The value for dairy cattle, 118 MJ/animal/day, is from the Agriculture Agency of the Faroe Islands. Since the GE for non-dairy cattle and sheep was not complete this year, the GE for these has been estimated by scaling the value relative to the corresponding Icelandic values¹. In Table 7 GE for cattle, where the calculated values are in italic.

Table 7 GE values for Cattle and sheep (MJ/head/day).

	Dairy cattle	Non-dairy cattle	Sheep
Faroe Islands	118	83	12
Iceland	250	175	25

Table 8 lists the Y_m factor recommend in IPCC 2006.

Table 8 Methane conversion factor – Y_m.

Livestock category	Y _m , %

¹ ICELAND National Inventory Report. <https://unfccc.int/documents/273420>.

Dairy cattle	6.5
Non-Dairy	6.5
Mature sheep	6.5
Lamb	4.5

Reference: IPCC 2006, Table 10.12 and 10.13.

Figure 17 shows emissions of CH₄ from enteric fermentation in livestock on the Faroe Islands, 1990-2020.

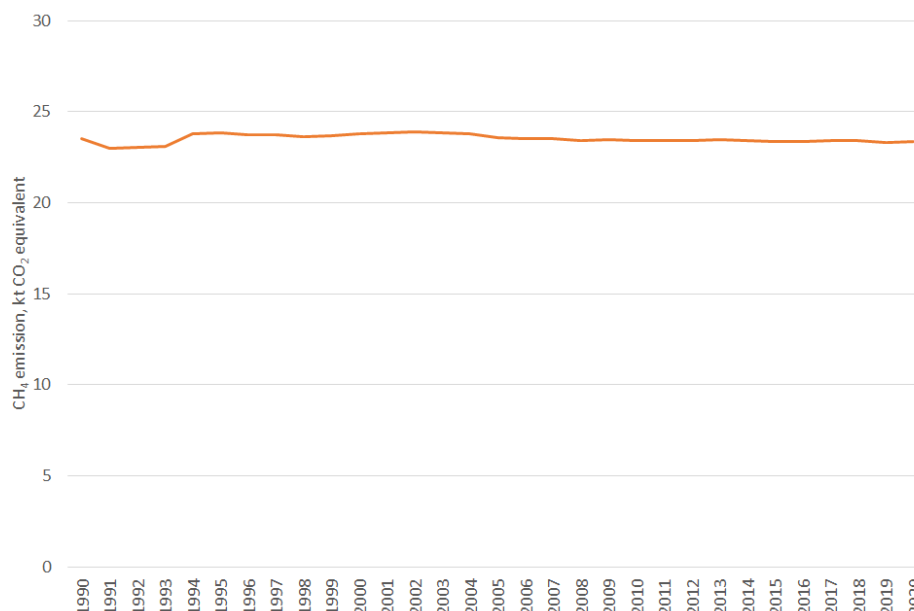

Figure 17 CH₄ emissions in CO₂ equivalents from enteric fermentation, 1990-2020.

CH₄ emission from Manure Management (CRF Sector 3B)

To calculate the CH₄ emission from manure management, information is needed about:

- The content of volatile solid (VS) in manure
- Allocation on manure management system

Based on this information an average CH₄ emission per animal per year has been estimated. See IPCC 2006 calculation equation below:

EQUATION 10.23
CH₄ EMISSION FACTOR FROM MANURE MANAGEMENT

$$EF_{(T)} = (VS_{(T)} \cdot 365) \cdot \left[B_{o(T)} \cdot 0.67 \text{ kg} / \text{m}^3 \cdot \sum_{S,k} \frac{MCF_{S,k}}{100} \cdot MS_{(T,S,k)} \right]$$

Where:

$EF_{(T)}$ = annual CH₄ emission factor for livestock category T , kg CH₄ animal⁻¹ yr⁻¹

$VS_{(T)}$ = daily volatile solid excreted for livestock category T , kg dry matter animal⁻¹ day⁻¹

365 = basis for calculating annual VS production, days yr⁻¹

$B_{o(T)}$ = maximum methane producing capacity for manure produced by livestock category T , m³ CH₄ kg⁻¹ of VS excreted

0.67 = conversion factor of m³ CH₄ to kilograms CH₄

$MCF_{(S,k)}$ = methane conversion factors for each manure management system S by climate region k , %

$MS_{(T,S,k)}$ = fraction of livestock category T 's manure handled using manure management system S in climate region k , dimensionless

The content of volatile solid (VS) in manure has been calculated, see the IPCC equation below.

EQUATION 10.24
VOLATILE SOLID EXCRETION RATES

$$VS = \left[GE \cdot \left(1 - \frac{DE\%}{100} \right) + (UE \cdot GE) \right] \cdot \left[\frac{1 - ASH}{18.45} \right]$$

Where:

VS = volatile solid excretion per day on a dry-organic matter basis, kg VS day⁻¹

GE = gross energy intake, MJ day⁻¹

DE% = digestibility of the feed in percent (e.g. 60%)

(UE • GE) = urinary energy expressed as fraction of GE. Typically 0.04GE can be considered urinary energy excretion by most ruminants (reduce to 0.02 for ruminants fed with 85% or more grain in the diet or for swine). Use country-specific values where available.

ASH = the ash content of manure calculated as a fraction of the dry matter feed intake (e.g., 0.08 for cattle). Use country-specific values where available.

18.45 = conversion factor for dietary GE per kg of dry matter (MJ kg⁻¹). This value is relatively constant across a wide range of forage and grain-based feeds commonly consumed by livestock.

Table 9 shows the values used in the calculation of VS. For DE is used IPCC default, 70% for dairy cattle and 60% for non-dairy cattle, mother sheep and lamb. Furthermore, IPCC default is used for UE, 0.04 and ASH content, 8% for all animal categories.

Table 9 Values used to estimate the volatile solid (VS) in manure.

Livestock category	GE	DE - Digestibility	UE - urinary energy	ASH	VS
	MJ/head/yr	%		%	kg dry matter /head/day
Dairy cattle	118	70	0,04	8	0,4
Non-Dairy	83	60	0,04	8	0,5
Mature sheep	12	60	0,04	8	0,5
Lamb	(*)	60	0,04	8	0,5

(*) Lamb will be included in next year's reporting.

The estimate for VS is used as input data for calculation of the CH₄ emission factor from manure management. The emission is depending on the manure type, which must be reflected, thus emission from liquid manure is higher compared to solid manure.

Table 10 presents the parameters used in the calculations of the EF(T). The values for the methane conversion factor (MCF) and the maximum methane producing capacity (B₀) are based on the IPCC default. The allocation of manure management system is based on information from the Faroese Agriculture Agency.

Table 10 Parameters used to calculate the average CH₄ emission per animal (Dairy, Non-Dairy and Sheep) per year.

	MMS	VS	B₀	MCF	CH₄ EF
		kg dry mat-	M ³ /kg CH ₄ /VS		
Dairy cattle	% allocation	ter/head/day	excreted	% Kg CH ₄ /head/yr	
Total	100				
Liquid/slurry	17	2,0	0,24	17	19,96
Solid storage	0	2,0	0,24	2	2,35
Dry lot	0	2,0	0,24	1	1,17
Pasture	0	2,0	0,24	1	1,17
Daily spread	0	2,0	0,24	0,1	0,12
Digester	83	2,0	0,24	10	11,74
Burned for fuel	0	2,0	0,24	10	11,74
Other	0	2,0	0,24	1	1,17
CH ₄ weighted EF, kg CH ₄ /head/yr					13,14

	MMS	VS	B₀	MCF	CH₄ EF
		kg dry mat-	M ³ /kg CH ₄ /VS		
Non-Dairy cattle	% allocation	ter/head/day	excreted	% Kg CH ₄ /head/yr	
Total	100				
Liquid/slurry	17	1,8	0,18	17	13,63
Solid storage	0	1,8	0,18	2	1,60
Dry lot	0	1,8	0,18	1	0,80
Pasture	0	1,8	0,18	1	0,80
Daily spread	0	1,8	0,18	0,1	0,08
Digester	83	1,8	0,18	10	8,02
Burned for fuel	0	1,8	0,18	10	8,02
Other	0	1,8	0,18	1	0,80
CH ₄ weighted EF, kg CH ₄ /head/yr					8,97

	MMS	VS	B₀	MCF	CH₄ EF
		kg dry mat-	M ³ /kg CH ₄ /VS		
Mature sheep	% allocation	ter/head/day	excreted	% Kg CH ₄ /head/yr	
Total	100				
Liquid/slurry	0	0,3	0,19	17	2,08
Solid storage	20	0,3	0,19	2	0,24
Dry lot	0	0,3	0,19	1	0,12
Pasture	80	0,3	0,19	1	0,12
Daily spread	0	0,3	0,19	0,1	0,01
Digester	0	0,3	0,19	10	1,22
Burned for fuel	0	0,3	0,19	10	1,22
Other	0	0,3	0,19	1	0,12
CH ₄ weighted EF, kg CH ₄ /head/yr					0,15

Figure 18 shows emissions of N₂O and CH₄ from manure management on the Faroe Islands, 1990-2020, in CO₂ eqv. The emissions are very stable. The total yearly emission in recent years is around 1.700 tonnes of CO₂ eqv. The total GHG emission is comprised of roughly half CH₄ and half N₂O.

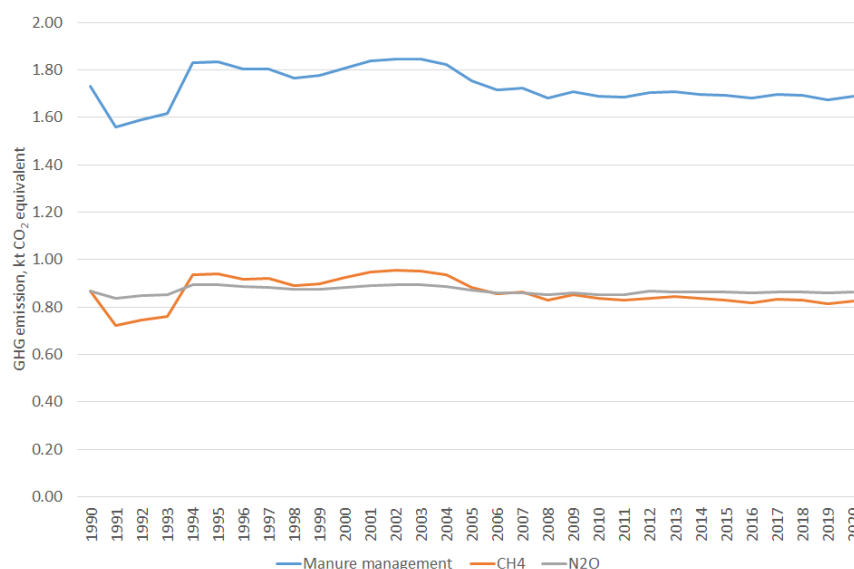

Figure 18 N₂O and CH₄ emission in CO₂ eqv. from Manure management, time series 1990-2020.

N₂O emission from Manure Management (CRF Sector 3B2)

The N₂O emission from manure management is divided into the direct emission and the indirect emission. The direct emission is depended on the manure type, while the indirect emission is from the volatilization of NH₃ and NO₂ (housing and storage), which also leads to N₂O emission. The emissions needed to have information on the animals N-excretion in manure and allocation of manure management system. N₂O emission from grassing animals is reported under CRF Table 3.D.

Conversion of N₂O-N emissions to N₂O emissions for reporting purposes is performed by using the following equation: N₂O = N₂O-N * 44/28.

Direct N₂O emission

The animal N-excretion is calculated based on the IPCC 2006 equation 10.30 (see below).

EQUATION 10.30
ANNUAL N EXCRETION RATES

$$Nex_{(T)} = N_{rate(T)} \cdot \frac{TAM}{1000} \cdot 365$$

Where:

$Nex_{(T)}$ = annual N excretion for livestock category T , kg N animal⁻¹ yr⁻¹

$N_{rate(T)}$ = default N excretion rate, kg N (1000 kg animal mass)⁻¹ day⁻¹ (see Table 10.19)

$TAM_{(T)}$ = typical animal mass for livestock category T , kg animal⁻¹

Information on typical animal mass for cattle and sheep is from Faroese Agricultural Agency. The values are: Dairy Cattle: 650 kg. Non-dairy cattle 400 kg and sheep 45 kg. The values for N-rate (kg N exc. per 1000 kg animal weight) refer to IPCC 2006 default (Table 10.19) for Western Europe. The weighted N-excretion for mature sheep and lamb is 10 kg N/head/yr, which match the average N-exr. for sheep for Iceland, Norway, and Finland.

Table 10 Variable used for estimation the N-excretion.

	N-rate	TAM	N-excretion
	Kg N-ex/1000 kg animal weight/day	Animal weight	Kg N-ex/head/yr
Dairy Cattle	0.48	600	105.12
Non-dairy cattle	0.33	400	48.18
Mature sheep	0.85	45	13.96

Besides the animals N-excretion, the direct N₂O emission depends on the allocation of manure management system, because the emissions factor varies between the manure types. Se IPCC equation below.

EQUATION 10.25
DIRECT N₂O EMISSIONS FROM MANURE MANAGEMENT

$$N_2O_{D(mm)} = \left[\sum_S \left[\sum_T (N_{(T)} \cdot Nex_{(T)} \cdot MS_{(T,S)}) \right] \cdot EF_{3(S)} \right] \cdot \frac{44}{28}$$

Where:

$N_2O_{D(mm)}$ = direct N₂O emissions from Manure Management in the country, kg N₂O yr⁻¹

$N_{(T)}$ = number of head of livestock species/category *T* in the country

$Nex_{(T)}$ = annual average N excretion per head of species/category *T* in the country, kg N animal⁻¹ yr⁻¹

$MS_{(T,S)}$ = fraction of total annual nitrogen excretion for each livestock species/category *T* that is managed in manure management system *S* in the country, dimensionless

$EF_{3(S)}$ = emission factor for direct N₂O emissions from manure management system *S* in the country, kg N₂O-N/kg N in manure management system *S*

S = manure management system

T = species/category of livestock

44/28 = conversion of (N₂O-N)_(mm) emissions to N₂O_(mm) emissions

The distribution on different manure management systems for cattle and sheep are provided by the Agriculture Agency of the Faroe Islands.

The N₂O emission factor for each manure type is based on the IPCC 2006 default, Table 10.21 and Table 11.1 for grassing animals. Note that N₂O for animal on grass is reported in CRF Table 3D (agricultural soils).

Indirect N₂O emission (housing + storage)

The indirect N₂O emission depends on the amount of N, which are volatilities as NH₃ and NO₂- see IPCC equation below. The volatilization is estimated based on NH₃ and NO₂ emission factor from the EMEP Guidebook 2019 Table 3.2 and Table 3.3, which distinguish between liquid and solid manure.

EQUATION 10.27
INDIRECT N₂O EMISSIONS DUE TO VOLATILISATION OF N FROM MANURE MANAGEMENT

$$N_2O_{G(mm)} = (N_{volatilization-MMS} \cdot EF_4) \cdot \frac{44}{28}$$

Where:

$N_2O_{G(mm)}$ = indirect N₂O emissions due to volatilization of N from Manure Management in the country, kg N₂O yr⁻¹

EF_4 = emission factor for N₂O emissions from atmospheric deposition of nitrogen on soils and water surfaces, kg N₂O-N (kg NH₃-N + NO_x-N volatilised)⁻¹; default value is 0.01 kg N₂O-N (kg NH₃-N + NO_x-N volatilised)⁻¹, given in Chapter 11, Table 11.3

N₂O emission from Agricultural Soils (CRF Sector 3D)

Figure 19 shows the N₂O emissions from agricultural soil. Since the number of animals is constant, the emissions are constant also. The peak in 1994 will be further investigated for the next submission. There seems to be an inconsistency in the grassland area causing the peak in emissions from crop residues.

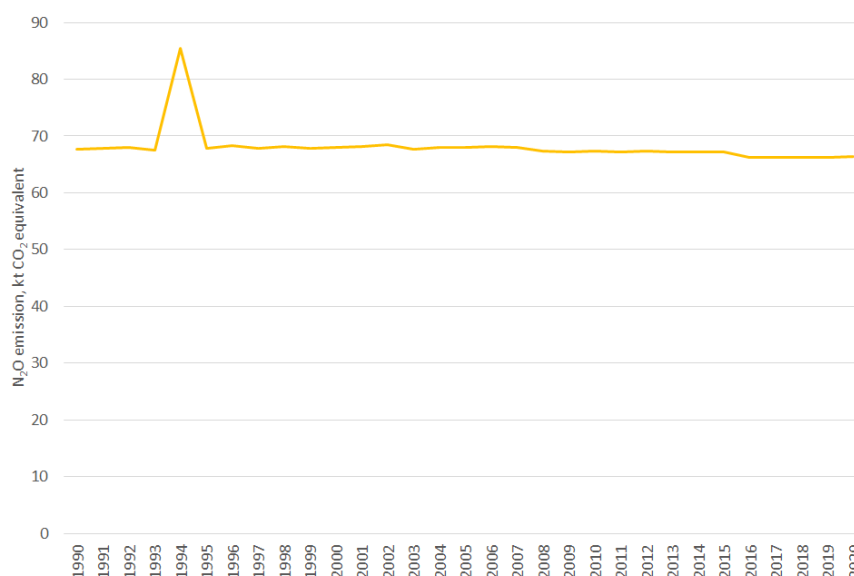

Figure 19 N₂O emissions (tonnes CO₂ eqv.) from Agricultural Soils, time series 1990-2020.

All N applied to the agricultural soil will lead to emission of N₂O. The N₂O emission from cultivation of agricultural soils is divided into two groups, direct and indirect emission. The direct emissions include sources which are related directly to nitrogen applied on soil as fertilizer during inorganic fertilizer or animal manure applied or during grassing, this also includes N from N turnover from crop residues. The indirect emission includes N₂O emission from the emission sources where a volatilization of NH₃ and NO₂ take place (atmospheric deposition). Furthermore, a N₂O emission also occurs from leaching of N to the groundwater, water streams and the sea.

Direct N₂O emissions

Inorganic fertilizers

Data on import of NPK fertilizer to the Faroe Islands are used to calculate the N₂O emission from use of inorganic fertilizer. Most of the fertilizers are of the type “19-3-13” i.e., with 19 % N. See Table 11. The N₂O emission factor 0.01 kg N₂O-N/kg N applied is the default value from the IPCC 2006 Table 11.1.

Table 11 Import of inorganic fertilizers to the Faroe Islands (kt), 1990, 2000, 2010-2020.

	1990	2000	2010	2011	2012	2013	2014	2015	2016	2017	2018	2019	2020
Import (kt)	1.097	1.373	1.005	869	966	883	942	856	12	4	2	8	117
19 % N (kt)	208	261	191	165	184	168	179	163	2	1	0	1	22

The import numbers will be revised in next year’s reporting.

The emissions of NH₃ and NO₂ are calculated because these values are part of the calculation of atmospheric deposition. These emission factors are based on EMEP Guidebook 3D 2019 Table 3.1, corresponding to 0.05 kg NH₃/kg N applied and 0.04 kg NO₂/kg N applied and converted to 0.04 kg NH₃-N/kg N applied and 0.01 kg NO₂-N/kg N applied.

Organic fertilizers

This source includes products used for fertilizes the soil, e.g., animal manure or other products with nitrogen content.

The amount of N applied in form of animal depends on the livestock category. The N applied to agricultural soils are N excreted minus the emission of NH₃, NO₂ and N₂O, which has taken place in housing and storage. The N₂O emission factor is 0.01 kg N₂O-N/kg N applied based on the IPCC default (IPCC 2006, Table 11.1). The allocation of manure management system (MMS) in the Faroe Islands is in **Error! Reference source not found.** The emission factor for NH₃ is based on the EMEP GB 3B Table 3.2 and emission factor for NO₂ is based on EMEP GB 3B Table 3.3.

Sewage sludge applied to soils and other organic fertilizers applied to soils

In the Faroe Islands, the soil is sometimes in certain areas fertilized with salmon ensilage and with biofertilizers from the new biogas plant Förka. The production of organic matter from the biogas plant in 2020 is in Table 12. Since manure is included in the calculation of N₂O from Manure Management, only 15 % are included in other organic fertilizers applied to soils.

Input data is the amount of N applied to the soil. The N₂O emission factor is 0.01 kg N₂O-N/kg N applied based on the IPCC default (IPCC 2006, Table 11.1).

Table 12 Type of organic matter delivered to the biogas plant in 2020.

Type of organic matter	Amount (m3)	Amount (%)
Manure	18170	85 %
Ensilage, salmon	3165	15 %
Excrements from salmon hatchery	37	0,2 %
Other – fish	80	0,4 %
Total	21452	100 %

The N-content in the biofertilizers, which is used to calculate the amount of N, is 5.2 kg/t. Salmon ensilage is not reported this year, due to lack of data on N-content. Sewage sludge is not used as fertilizers on the Faroe Islands.

The emission of NH₃ and NO₂ from applied organic fertilizer are estimated and included in “atmospheric deposition”. The emission factor for NH₃ and NO₂ is based on default values from the EMEP Guidebook 2019 3D, Table 3.1.

Urine and dung deposited by grazing animals

The N₂O emission from grassing animals is estimated as the total N excreted multiply with the default N₂O emission factor, which is 0.02 kg N₂O-N/kg N excreted for cattle and 0.01 N₂O-N/kg N excreted for sheep (IPCC Table 11.1).

The emission of NH₃ and NO₂ from grassing animal is included in emission source “Atmospheric deposition” (3.D.b.1). The NH₃ emission factor is default values from the EMEP guidebook 2019 3B Table 3.2 and the NO₂ emission factor is based on EMEP GB 2019 3D Table 3.1

Mineralization/immobilization associated with loss/gain of soil organic matter

The N₂O emission from the mineralization is considered as a relatively small emission source, because the Faroe Island has a limited cultivated area, only some potatoes and grassing fields. The emissions will be considered for next year’s reporting.

Crop residues

The turnover from nitrogen in crop residues, from roots and leaf, will over time lead to a N₂O emission, and the emission depends on the N content in the crop residue. Due to Búnaðarstovan (BST) the total agricultural area is estimated to 97,800 hectares, mostly grassland and few potatoes, between 80 – 116 hectares (FAO Statistics). The calculation of N₂O emission from crop residues is based on the 2006 IPCC Guidelines methodology, where default values are given for the N content per dry matter, and the fraction of the dry matter content between the crop residue below and above ground (IPCC 2006, Table 11.2). The yield for potato and grass in the Faroe Islands is in Table 13.

Table 13 Data for harvest (kg/ha), Dry matter fraction of harvest product (kg dry matter/kg harvest) and harvest (kg dry matter/ha).

2020 - Total N in residue, mill. kg N	Above ground residue		
	Dry matter fraction		Harvest kg dm/ha
	Harvest kg/ha	of harvest product kg dm/kg harvest	
Potato	40000	0.20	8000
Perennial grasses	22000	0.22	4840

Potatoes

With a dry matter (dm) content of 0.20 kg dm/kg harvest, the kg dm content is estimated to approximately 8.000 kg dm/hectare. Calculation by the IPCC methodology and values, this leads to an N content by 40 kg N per hectare potato.

Perennial grasses

For grassland is assumed a yield by 4.840 kg dm per hectare. Calculation by the IPCC methodology and values, this leads to a N content by 82 kg N per hectare grassland.

The default N₂O emission factor at 0.01 kg N₂O-N per kg N in crop residues is used, based on IPCC default (IPCC Table 11.1).

Table 14 The agricultural area

	1990	1995	2000	2005	2010	2015	2016	2017	2018	2019	2020
Agricultural area.											
cropland + grassland	98 345	98 225	98 121	98 053	97 916	97 831	97 816	97 811	97 811	97 810	97 810
Potatoes, ha	106	109	107	102	100	97	89	85	82	80	80
Grassland, ha	98 239	98 116	98 014	97 951	97 816	97 734	97 727	97 726	97 729	97 730	97 730

Reference: Total agricultural area and potato and grass: Búnaðarstovan.

Indirect N₂O emissions

Atmospheric deposition

Volatilization of NH₃ and NO₂ and the deposition of these gases and products onto soils and the surface of lakes and other water bodies cause N₂O emission. Emission of N₂O is calculated based on all:

- NH₃ emission sources; manure applied to soil, inorganic N fertilizer, and other organic matter used as fertilizer, grazing animals
- NO₂ emission sources; manure applied to soil, inorganic N fertilizer, and other organic matter fertilizer.

The N₂O emission factor, 0.01 kg N₂O-N per kg NH₃ and NO₂ volatilized is based on the IPCC default (IPCC 2006, Table 11.3).

Table 15 Calculation of N₂O emission from atmospheric deposition.

kg N volatilise as NH ₃ -N and NO ₂ -N	1990	1995	2000	2005	2010	2015	2020
Inorganic N fertilizers	11119	11040	13916	14942	10187	8675	1186
Animal manure applied to soils (application)	56065	58769	57734	56444	54583	55801	55956
Urine and dung deposited by grazing animals	70104	70104	70104	70104	70104	70104	70104
Sewage sludge applied to soils	0	0	0	0	0	0	0
Other organic fertiliser	0	0	0	0	0	0	1
Total kg N volatilise as NH ₃ -N and NO ₂ -N	137288	139913	141754	141490	134873	134579	127246
N ₂ O EF, kg N ₂ O-N/kg NH ₃ -N + NO _x -N volatilised*	0,01	0,01	0,01	0,01	0,01	0,01	0,01
Emission, kt N ₂ O	0,00216	0,00220	0,00223	0,00222	0,00212	0,00211	0,00200

Nitrogen leaching and run-off

The emission of N₂O from N-leaching and runoff is calculated based on the total amount of N applied to the agricultural soils, multiplied with the share N amount which expects to be lost to leaching and runoff, multiplied with the N₂O emission factor. The N applied is the sum of all sources contribute to N application as shown in Table 16. The IPCC default for FRacLeach, which is 0.3 kg N/ kg N applied is used (IPCC Table 11.3). The IPCC default is also used regarding the N₂O emission factor, 0.0075 kg N₂O-N/kg N leaching/runoff (IPCC Table 11.3).

Table 16 The calculation of N₂O emission from N-leaching and runoff.

Kg N applied	2020
N applied from inorganic fertilizer	22231
N applied from animal manure applied	1822624
N applied from sewage sludge	0
N applied from other organic fertilizer	6867
N applied from animal on grass	1481146
N applied from crop residue	8034955
N applied from mineralization	0
N applied total	11360964
FracLeach, kg N/ kg N applied (IPCC default)	0.3
N-leached and run-off	3408289
kg N ₂ O-N/kg N leaching/runoff (IPCC default)	0.0075
Emission, kt N ₂ O	0.402

Uncertainties

The uncertainties have not been calculated.

Recalculation

No recalculations were made in the Agriculture section in this submission.

Land Use, Land-Use Change and Forestry (CRF Sector 4)

The Faroe Islands are located in the Atlantic Ocean between Great Britain and Iceland with the Capitol, Tórshavn on 62.01°N and -6.87°E. The Faroe Islands consist of 18 islands, in total 1394 km² (app. 36*36 km²). The islands are rocky

where perennial grass is the dominating plant cover. The highest point, Slætataratindur, translated as “flat summit”, is the highest mountain in the Faroe Islands, towering at 880 meters.

The climate is cold and wet with an annual average temperature of 7 °C (1991-2020). Due to its position in the Atlantic Ocean and the Gulf Stream there is only a small variation in the temperatures between winter and summer (DMI, 2021). The mean winter temperature is around 4 °C and the mean summer temperature is around 11 °C, Figure 20, which according to the IPCC 2006 Guidelines classification is “Cool Temperate Moist.” The annual precipitation is high and around 1400 mm yr-1 with most rain in the autumn, November to January.

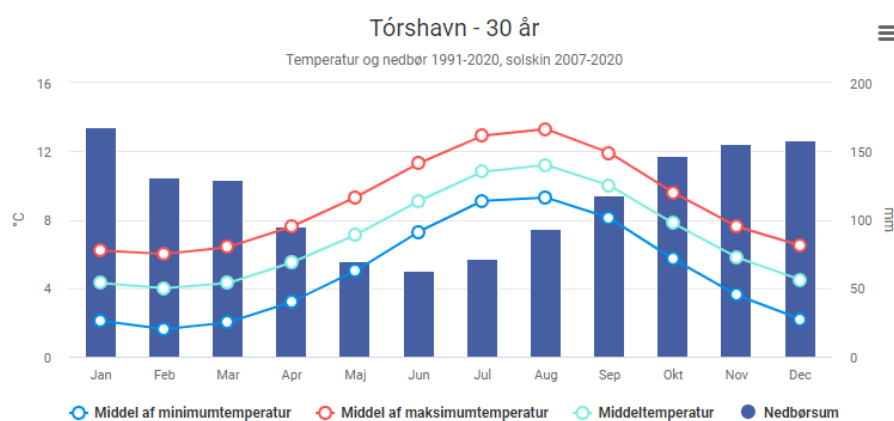

Figure 20 Average climate data for Tórshavn on the Faroe Islands, 1991-2020 (DMI, 2021, <https://www.dmi.dk/vejarkiv/normaler-faroerne/>)

Due to the rather cold climate and grazing sheep (see the agricultural sector, 3.A) perennial wooden plants seldom occurs. Minor areas with primarily pine (*Pinus spp.*) can be found in plantages/parks, which often also are protected areas. To facilitate and protect wooden crops/afforestation, the Faroe Islands implemented protection of some areas with fencing and included these in the legislation (in Faroese, “Skógfriðing.”) many years ago. The mild climate facilitate year around grazing where the sheep is excluded from designated high value grassland areas (indmark, bœur). During the spring period and while the sheep give birth to lambs, the sheep are allowed to graze in these more fertile areas which cover around 6 % of the total Grassland area. Grassland or “hagi” in Faroese, where sheep are roaming, is unfertilized and with medium to sparse grass vegetation where the rocky underground is approaching the surface, see Figure 22.

Land Use Matrix

The land use matrix is based on the best available data. The Faroe Islands has been grazed for the last 1000 years and annual agricultural crops is limited due to the low temperatures. Therefore, the dominating land use is grassland with only minor changes over time and mainly to Settlement such as houses and infrastructures. Over the past decades, more permanent grassland has been established to improve the grass quality, but although limited.

A new National Forest Definition has been defined for the purpose of the reporting to UNFCCC.

A GIS analysis was performed in 2021 (Umhvørvisstovan, 2021) to establish a classification of the six IPCC land use classes defined as per 31. December

2020. In 2016 topographic vector data was collected with an intended chart scale of 1:20 000. The topographic dataset was captured using mainly satellite images (Pleiades) and orthophotos. However, some national source data was included, e.g., roads and buildings. The data was coded according to the Multinational Geospatial Co-production Program Technical Reference Documentation 4.3, with some additions. When tasked to complete the land use matrix, the topographic dataset was considered to be the best available source.

In order to fit the classification of the land use matrix, some feature classes of the topographic dataset had to be grouped, e.g., for Wetlands and Other land, and all included land use features needed to be managed logically and geometrically. Buffers had to be created for points and line features and the new area geometry subtracted from the underlying and overlapping land use coverage. This procedure was performed using ESRI ArcGIS software.

Wetlands

Natural Pool Point Features were estimated to have a radius of 4 m. River Line Features and Ditch Line Features were given buffers according to the width encoded for each feature.

Other land

Road Line Features were given a buffer of 6 m. Road areas inside built-up areas (settlements) were not included in the area calculation of Other land.

As the Faroe Islands is not fully matriculated and roads are only lines on a map, GIS analyses were performed to achieve area estimates. The outcome per 31. December 2020 is shown in Table 17. Forest covers only 34.7 ha, Grassland 70 % of the area. Settlements 1.5 % and Other Land 27 %.

Table 17 Area estimates and changes in hectares for the six IPCC land use classes from 1. January 1990 to 31. December 2020.

1990\2020	Forest	Cropland	Grassland	Wetlands	Settlements	Other	Sum
Forest	28	0	0	0	0	0	28
Cropland	0	0	0	0	0	0	0
Grassland	6	3	97.807	0	276	0	98.090
Wetlands	0	0	0	2.037	0	0	2.037
Settlements	0	0	0	0	1.722	0	1.722
Other	0	0	0	0	92	37.629	37.724
Sum	34.7	3	97.807	2.037	2.090	37.629	139.600
Percentage	0 %	0 %	70 %	1.5 %	1.5 %	27 %	100 %

The forest area has been estimated to 34.7 ha, CL to 3, GL to 97.807 ha, wetlands to 2.037 ha, SE to 2.090 ha and other land to 37.629 ha. The Faroe Islands is using a 20 yr transition period in the UNFCCC reporting as recommended by IPCC (IPCC, 2006). To achieve this combined with a full reporting from 1990, a land use matrix has been extrapolated back to 1971 based on existing data. These are often based on expert judgment. However, for land converted to SE has a GIS analyse been performed including information on road constructions. Conversion of Grassland to Cropland is based on expert judgment. Afforestation is based on information from Umhvørvisstovan (Umhvørvisstovan, 2021).

Total emission from the LULUCF sector

The total emission from the LULUCF sector on the Faroe Islands has been estimated to 34.9 Gt CO₂ eqv. see Table 18. The emission is primarily due to emissions from drained organic grassland. Forest land is a very minor sink on the Faroe Islands. Cropland consists of only a few hectares in 2020 and no emissions have been reported from here as well as from managed Wetlands. Settlements are reported as a minor source due to clearance of living biomass when housing and roads are reported.

Table 18 Total emissions from the LULUCF sector, kt CO₂ eqv.

	1990	2000	2010	2015	2016	2017	2018	2019	2020
A. Forest land	0.00	0.00	0.00	0.00	0.00	0.00	0.00	0.00	0.00
B. Cropland	NA	NA	NA	NA	NA	NA	NA	NA	NA
C. Grassland	33.97	34.51	35.15	35.27	35.29	35.32	35.34	35.36	34.91
D. Wetlands	NA	NA	NA	NA	NA	NA	NA	NA	NA
E. Settlements	0.05	0.05	0.09	0.05	0.05	0.00	0.00	0.00	0.00
F. Other land	NA	NA	NA	NA	NA	NA	NA	NA	NA
G. Harvested wood products	NE	NE	NE	NE	NE	NE	NE	NE	NE
H. Other	NA	NA	NA	NA	NA	NA	NA	NA	NA
4. Land use, land-use change and forestry	34.02	34.56	35.24	35.32	35.34	35.32	35.34	35.36	34.91

Forest land

The area with forest on the Faroe Islands is limited. For the purpose of reporting, the Faroe Islands has made the following forest definition.

- 1) All areas which are protected by a forest reserve declaration (“Skóg-friðað”)
- 2) Other not protected areas with forest/woody vegetation excluding minor areas inside
 - a) Some areas within Settlements like Sjómannsskúlatrøðin, Müllerstrøð and Debesartrøð
 - b) Areas which are part of nurseries (Gróðurstøðin)
 - c) Some private areas like Viðarlundin í Sortudýki

Per 31. December 2020, the total estimated afforested area was 34.7 ha. For estimating the actual carbon stock and due to the sparse vegetation, a Danish developed model for hedges is used where the carbon stock estimation is based on vegetation volume, which is converted to carbon. It is not assumed that forest growth takes place on organic soils. Area and emission from organic forest soils is hence reported as Not Occurring (NO) and with zero emission (NA). As default no changes is assumed to occur in the soil organic carbon pool (IPCC, 2006), both for Forest Land remaining Forest Land and in land converted to Forest Land. Deforestation does not occur on the Faroe Islands. No dead wood can be found in the small areas with trees and is therefore reported as NO. The same for litter.

FL remaining FL and Land converted to FL

By the end of 2020, the total Forest area was estimated to 34.7 hectare. This is based on the GIS analysis made by Umhvørvisstovan in 2021. The total forest area consists of 76 individual forest parcels, each having been assigned a planting year with the earliest planting in 1914.



Figure 21 Successful afforestation near Tórshavn (left), partly successful afforestation near Tórshavn (middle) and on-going afforestation (and restoration) near the village Kirkjubøur. (Photo: Steen Gyldenkærne, Aarhus University, Denmark).

For the purpose of estimating the carbon stock, all parcels has been assigned with a plant cover and plant height in 1970, 1990, 2010 and 2021. Height at planting has as default been set to 0.5 meter. For the mentioned years, a linear interpolation of plant cover and plant height has been used to estimate the canopy volume. The canopy volume has been converted to biomass with a conversion factor of 2.538 kg dry matter biomass per m³ canopy (Levin et al. 2020), a carbon content of 0.48 and a root:shoot-factor of 0.192 (IPCC, 2006). For conversion to CO₂ eqv., the recommended conversion factors for 100 years of 25 for CH₄ and 298 for N₂O (AR5) are used. Conversion of N₂O-N to N₂O is made with multiplying with the atomic weight, i.e. 44/28.

Table 19 Parameters used to estimate emission from LULUCF. No changes in mineral soils are expected.

	Aboveground kg dry matter m ⁻³ biotope		Root:Shoot, fraction	C fraction	C loss organic soils, kg C ha ⁻¹ yr ⁻¹	CH ₄ emission organic soils, kg CH ₄ ha ⁻¹ yr ⁻¹	N ₂ O-N emission organic soils, kg N ₂ O-N ha ⁻¹ yr ⁻¹
4.A. Forest land	2.538		0.192	0.48	NA	7	NA
	Dry matter stock, Aboveground biomass, kg DM ha ⁻¹	Total dry matter stock, kg DM ha ⁻¹	Root:Shoot, fraction	C- content, kg C kg ⁻¹ OM, fraction	C loss or- ganic soils, kg C ha ⁻¹ yr ⁻¹	CH ₄ emission organic soils, kg CH ₄ ha ⁻¹ yr ⁻¹	N ₂ O-N emis- sion organic soils, kg N ₂ O- N ha ⁻¹ yr ⁻¹
4.B.1.1 Cropland, Annual crops	2400	13600	0.24	0.48	-3600	1.4	1.6
4.C.1.1. Grassland, Intensive Managed	2400	13600	0.24	0.48	-3600	1.4	1.6
4.C.1.2. Grassland, Slightly Managed	1200	6800	0.24	0.48	-1800	0.7	0.8
4.C.1.3 Grassland, Unmanaged, where sheep roam	240	1360	0.24	0.48	0	0	0
4.D.1.1 Wetlands, Lakes and streams	NE	NE	NE	NE	NE	NE	NE
4.D.1.2 Wetlands, Bogs and swamps	NE	NE	NE	NE	NE	NE	NE
4.E. Settlement	600	3400	0.24	0.48	NA	NA	NA
4.F. Other land	NO	NO	NO	NO	NA	NA	NA

When land use conversion is taking place the standing stock of living biomass on the afforested area is removed. In the case of the Faroe Islands, afforestation is only taking place on fertile grassland. Table 20 shows the estimated emission from Forestry on the Faroe Islands in 2020 in CO₂ eqv.

Table 20 Estimated Forest area and emissions from the forests. Emissions are positive (+) and sinks are negative (-).

Forest land	1990	2000	2010	2015	2018	2019	2020
Forest Land remaining Forest Land, ha	20.30	28.35	34.07	34.07	34.07	34.07	34.49
Emission, kt CO ₂	-0.001	-0.001	-0.001	-0.001	-0.001	-0.001	-0.001
Land converted to Forest land, ha	13.78	6.14	0.42	0.42	0.58	0.58	0.16
Emission, kt CO ₂	0.000	0.000	0.000	0.000	-0.001	0.000	0.000
Forest area, total, ha	34.07	34.49	34.49	34.49	34.66	34.66	34.66
Emissions, total, kt CO ₂	-0.001	-0.001	-0.001	-0.001	-0.002	-0.001	-0.001

No N₂O and CH₄ emissions has been estimated from the unfertilized forestland.

Cropland

The climate on the Faroe Islands is not suitable for annual crops. Only three hectares are reported with annual crops, primarily potatoes. It is assumed that all three hectares are grown on mineral soils.

No emission is assumed in living biomass except during Land use conversion. Default parameters for living biomass in the six different land use classes are shown in Table 19.

CL remaining CL and Land converted to CL

The total area CL remaining CL has in 1990 been estimated to 0 ha and increased to 3 ha in 2020. No changes in the carbon stock are assumed in living biomass and in mineral soils. The default C stock on Cropland is assumed the same as for Grassland (IPCC, 2006). Despite the three hectares first were reported in 2006 all Cropland is reported under Cropland remaining Cropland.

In 1986, a thoroughly soil sampling was made on improved grassland on the Faroe Islands on all islands. In total, 296 soil samples, Table 21 (<https://www.bst.fo/Default.aspx?Id=14337>). Soil sampling depth was approximately 20 cm (Jens Ivan í Gerðinum, BST, personal communication).

Table 21 Result of soil sampling on the most fertile grassland in 1986 (Data from Búnaðarstovan, 2021).

	No of Samples	% distribution	Average % OM	Average bulk density, g/cm ³
>= 20 % OM	193	65 %	27.9	0.5
<20 % OM	103	35 %	14.1	0.7
Total	296	100 %	22.9	0.59

Organic soils are identified based on criteria 1 and 2, or 1 and 3 listed below (FAO 1998):

1. Thickness of organic horizon greater than or equal to 10 cm. A horizon of less than 20 cm must have 12 percent or more organic carbon when mixed to a depth of 20 cm.
2. Soils that are never saturated with water for more than a few days must contain more than 20 percent organic carbon by weight (i.e., about 35 percent organic matter).
3. Soils are subject to water saturation episodes and has either:
 - a. At least 12 percent organic carbon by weight (i.e., about 20 percent organic matter) if the soil has no clay; or

- b. At least 18 percent organic carbon by weight (i.e., about 30 percent organic matter) if the soil has 60% or more clay; or
- c. An intermediate, proportional amount of organic carbon for intermediate amounts of clay.

All other types of soils are classified as mineral. As can be seen from Table 21, 65 % out of 296 soil samples have 20 % Organic Matter (OM) or higher which qualify them as organic soils according to IPCC (2006). The soils are quite acidic with an average pH of 4.9 (Búnaðarstovan, 2021). For the three hectares with Cropland, it is assumed that they all are on mineral soils.

Although that the good part of the Cropland may contain some organic matter it is difficult to classify these as organic in terms of the IPCC guidelines (IPCC, 2006; IPCC, 2014) as many of them do not fulfil the FAO soil classification as having a depth of > 30 cm. Furthermore, the established emission factors in the IPCC 2013 Wetland Supplement (IPCC, 2014) seems not to be comprehensive for the Faroe conditions.

Grassland and Land converted to Grassland

Grassland on the Faroe Islands is divided into three categories. Intensively managed grassland, slightly managed grassland, and unmanaged grassland where sheep is roaming. Intensive managed Grassland has been estimated to around 1000 hectares, slightly managed to 6000 hectares and grassland where sheep is roaming to about 90 000 ha, Table 22. The marginal roaming grassland is called “hagi.” The sheep may also roam on Other Land. In total, 97 807 ha is classified as Grassland in 2020.

Animal manure and fertilization may take place on both intensively and slightly managed Grassland. The difference between intensive managed Grassland and slightly managed is that on the intensive managed Grassland, stone has been removed and new seeding of grass has been made. This occurs maybe with an interval of 30-50 years and is subsidized. The slightly managed grassland has not been tilled and only slightly ditched (see Figure 22). For reporting purposes, an emission factor of 50 % of the intensively managed soils has been elected.



Figure 22 Grassland turned into Intensive Managed Grassland (left), Ditch drained Grassland (middle), slightly managed Grassland (right) on the Faroe Islands (Photo: Steen Gyldenkærne, Aarhus University, Denmark).

For Grassland it is assumed that 65 % is on organic soils and 35 % on mineral soils based on the soil sampling made in 1986, Table 21.

The Unmanaged marginal Grassland is rocky and with a shallow soil layer. Very little data on the soils are available.

For Intensive managed organic grassland soils is assumed an annual emission of 3.6 tonnes C ha⁻¹ yr⁻¹ a CH₄ emission of 1.4 kg CH₄ ha⁻¹ yr⁻¹ and a N₂O emission of 1.6 kg N₂O-N ha⁻¹ yr⁻¹ (IPCC, 2014). Slightly managed Grassland is

assumed to have an emission of 50 % of the intensive managed Grassland. No CH₄ emission is assumed. It is assumed that none of the marginal grassland qualifies as being organic. In the reporting is thus all Unmanaged Grassland reported as mineral with no changes in the amount of living biomass and soil carbon stock.

As the Faroe Islands are hilly, no Cropland and Grassland areas occur with stagnant water. Thus, the likelihood for CH₄ emission from ditches is not likely and hence no CH₄ emission from ditches is reported. No estimates have been made for dissolved organic matter (DOC). This is therefore reported as NE.

Table 22 shows the estimated area and emissions from all Grassland on the Faroe Islands. In 2020, it is estimated that 4.648 hectares of organic soils may emit greenhouse gases. The total emission has been estimated to 36.9 kt CO₂ eqv. of which 0.007 kt N₂O (2.0 kt CO₂ eqv.) is reported in the agricultural sector in Table 3.D under 3.D.a.6.

Table 22 Area with Grassland and estimated emissions.

	1990	2000	2010	2015	2018	2019	2020
Grassland Land, total, ha	98.075	97.965	97.854	97.814	97.808	97.807	97.807
Grassland, Managed, ha	7.44	870	1.022	1.049	1.066	1.071	965
Grassland, Unmanaged, ha	6.409	6.283	6.129	6.101	6.085	6.079	6.185
Grassland Land, mineral soils, ha	93.426	93.315	93.206	93.166	93.160	93.160	93.159
Grassland Land, organic soils, ha	4650	4.650	4.648	4.648	4.648	4.648	4.648
Emission, kt CO ₂ -C	9.240	9.387	9.561	9.593	9.612	9.619	9.495
Emission, kt CH ₄	0.004	0.004	0.004	0.004	0.004	0.004	0.004
Emission, kt N ₂ O (reported under Agriculture)	0.006	0.007	0.007	0.007	0.007	0.007	0.007
Emission, kt CO ₂ eqv.	35.892	36.465	37.140	37.265	37.340	37.365	36.883

Wetlands

Based on the most recent GIS analysis performed by Umhvørvisstovan in 2021, Wetlands on the Faroe Islands consist of 1749 ha flooded land (inland lakes and streams) and 287 ha partly flooded land such as swamps. In total 2037 ha. The occurring wetlands are reported as unmanaged although some of the flooded land is water reservoirs for drinking water. No peat extraction is taking place and reported area with swamp.

No changes in the area with wetlands is reported and no emissions are reported from WE.

Settlement and Land converted to Settlement

Settlement consists of built-up areas, roads, and quarries. A GIS analysis performed in 2021 has estimated the area with built-up areas to 1823 hectare and roads and quarries to 267 hectares.

In 1990, the area with Settlement was estimated to 1733 hectare increasing to 2090 hectare in 2020. New dwellings are mainly taking place on former Grassland whereas road construction takes place both on Grassland and Other Land. It is assumed that 75 % of new SE is conversion of Grassland to SE and the remaining area is from Other land.

The GIS analysis performed in 2021 has also analysed road constructions and in this work the many tunnel constructions has been excluded from the land use change.

For Other Land converted to SE, no changes in the carbon stock in all reported carbon pools are assumed. For Grassland converted to SE, a conversion from slightly managed Grassland to SE having a default of 50 % in living biomass of slightly managed Grassland is assumed. No changes in soil carbon stock are assumed, mainly due to the likely very thin layer of soil above the rock, combined with the cold and wet climate, which reduce the turnover of organic matter. It is thus assumed that the recommendation of an 80 % value of the original carbon stock in Grassland in paved areas (IPCC, 2006, Chapter 8, Settlements, page 8.24) is not applicable for Faroese conditions.

Other Land

The GIS analyse has estimated the total Other Land area to 37629 hectares. From 1990 to 2020, the area has decreased due to road constructions and new dwellings. By definition, Other Land do not have any carbon stock.

References

Búnaðarstovan, 2021: Jens Ivan í Gerðinum, personal communication and data supplier of organic soils on the Faroe Islands.

Dalsgaard, 2021: Jóannes Dalsgaard, former director of the Jarðargrunnurin, Faroese Agricultural Funds, personal communication.

DMI, 2021, Climate data for the Faroe Islands, Available at:
<https://www.dmi.dk/vejrarkiv/normaler-faroerne/>

IPCC, 2006: 2006 IPCC Guidelines for National Greenhouse Gas Inventories, Prepared by the National Greenhouse Gas Inventories Programme, Eggleston H.S., Buendia L., Miwa K., Ngara T. and Tanabe K. (eds). Published: IGES, Japan.

IPCC, 2014: 2013 Supplement to the 2006 IPCC Guidelines for National Greenhouse Gas Inventories: Wetlands, Hiraishi, T., Krug, T., Tanabe, K., Srivastava, N., Baasansuren, J., Fukuda, M. and Troxler, T.G. (eds). Published: IPCC, Switzerland.

Levin, G., Angelidis, I. & Gyldenkærne, S. 2020: Assessment of change in biomass from 2006 to 2014/2015 of non-forest woody vegetation in Denmark. Technical documentation. Aarhus University, DCE – Danish Centre for Environment and Energy, 30 pp. Technical Report No. 178. Available at:
<https://dce2.au.dk/pub/TR178.pdf>

Umhvørvisstovan, 2021: Maria Gunnleivsdóttir Hansen and Stein Fossá, personal communication and documentation.

Umhvørvisstovan, 2021: GIS analyses. Hans Olof Engberg and Óluva Maria Højgaard.

Rutherford, G.K. & Taylor, C.E.B., 1981: The Soils of the Faeroe Islands. Rutherford and Taylor. 1981.

Búnaðarstovan, 1986: En undersøgelse af indhold af humus i færøsk jord.
<https://www.bst.fo/Default.aspx?Id=14337>

Bjarnason, Gunnar: Mundtlige oplysninger fra Gunnar Bjarnason, landbrugs-kandidat. March 2021.

Waste Sector (CRF Sector 5)

Overview of the Waste sector

Waste incineration is the only source in the Waste sector with significant emission. The emissions have been allocated to the energy sector in accordance with the IPCC Guidelines.

Solid Waste Disposal (CRF Source Category 5A)

Several land-based solid waste disposals facilities are located on the Faroe Islands.

In estimating emissions, the first order decay model included in the 2006 IPCC Guidelines has been used. The activity data (amounts and types of waste) are based on data and expert judgement from the Faroe Islands. For DOC, DOCf, MCF and T_{1/2}, the default values from the 2006 IPCC Guidelines are used. Climate is considered as wet and temperate. Most of the landfilled waste are inert materials, as combustible waste generally is incinerated and in prior times discarded directly into the sea. In 2019, the composition of the landfilled waste is assumed to be 71 % inert materials, 19 % sludge and 10 % garden waste.

Biological Treatment of Solid Waste (CRF Source Category 5B)

The first biogas facility on the Faroe Island, FORKA, did open in Hoyvík in 2020. Primarily receiving organic waste from the aquaculture industry and from agriculture.

Composting in the Faroes is primarily a small-scale activity in private households only. In recent years though, some Faroese municipalities, are about to establish compost sites where people can deliver their organic household waste, e.g., the municipality of Vágur in Suðuroy.

Incineration and Open Burning of Waste (CRF Source Category 5C)

There are two waste incineration plants on the Faroe Islands, one in Hoyvík and one in Leirvík. Both plants perform energy recovery operations and therefore the emissions from the plants have been allocated to the energy sector (Public Electricity and Heat Production, 1A1a) in accordance with the IPCC Guidelines. Figure 23 shows the amounts of waste incinerated on the Faroe Islands 1990-2020. A substantial increase in the amounts of burned municipal waste was seen in 2019, which was the same in 2020.

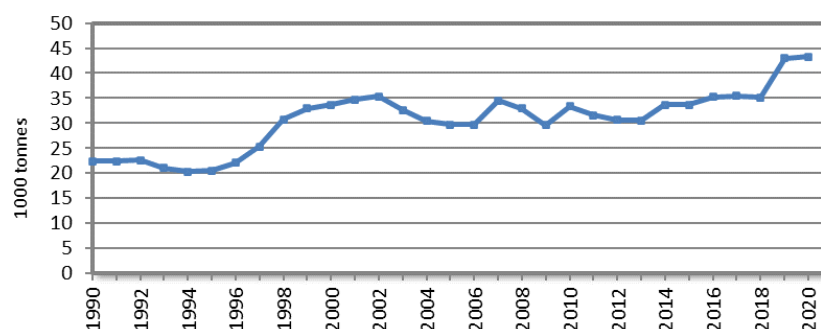

Figure 23 Incineration of municipal waste on the Faroe Islands, 1990-2019.

Open burning of waste is prohibited and is not occurring in the Faroes.

Wastewater Treatment and Discharge (CRF Source Category 5D)

In the Faroe Islands, many households have a septic tank through which domestic wastewater (sewage) flows for basic mechanical treatment. Industrial

wastewater, e.g., from the fishing industry, is treated mechanically (oil/fat separation). Only a very few wastewater handling plants are treating the wastewater chemically and/or biologically.

For CH₄ emissions from domestic wastewater, the TOW is estimated based on the population and the default value for BOD of 62 gram per person per day, the default value for additional industrial BOD discharged to sewers (1.25) and the B₀ default value (0.6 kg CH₄ per kg BOD). MCF values are the IPCC default values. The pathways for the wastewater are based on expert judgement and are under review. In this submission, it is assumed that 50 % of the wastewater is treated aerobically in plants, 40 % of the wastewater is treated in septic systems and the remaining 10 % is discharged directly into the sea. There are no anaerobic wastewater treatment systems in the Faroe Islands.

For industrial wastewater, only a few industries have separate wastewater treatment, especially the fishing industry. All treatment is done in aerobic plants and since the default MCF value is zero, there is no emissions reported from industrial wastewater treatment.

The N₂O emission is estimated both for the effluents and for the plants. As mentioned above, it is assumed that 50 % of the wastewater is treated in modern plants. The default EF of 3.2 g N₂O per person is used. For the N₂O from effluents, the emission is calculated based on the population, protein consumption data for Denmark and default values for fraction of nitrogen in protein, factor for non-consumed protein added to the wastewater and factor for industrial and commercial co-discharged protein into the sewer system. The EF is also the IPCC default of 0.005 kg N₂O-N per kg N.

Waste Other (CRF Source Category 5E)

There are no activities and emissions in the category Waste Other.

Other (CRF sector 6)

There are no activities, emissions or removals for the Other category in the inventory of the Faroe Islands.

Recalculations and improvements

Otherwise, most of the recalculations in the 2022 submission for the Faroe Islands are due to changes in emissions factors, and in all these cases, the changes are the same as in the inventory for Denmark, and thus explained in the main part of this report. These recalculations led to nearly no changes in the total emission, always less than 0,001 %. Also, some minor corrections have been made, with no substantial effect on the emissions trends or levels. Additionally, a number of improvements have been made as part of a project aimed to improve the inventory. The LULUCF-sector has been included in the inventory. This has increased the total emissions with around 2 % for the whole timeseries. Other new categories, in Agriculture and IPPU have also increased the emissions, but not substantially.

Explanations and justifications for recalculations

The following recalculations and improvements to the emission inventory have been made since the reporting in 2021.

Energy

Public Electricity and Heat Production

No changes in the emission factors.

Manufacturing Industries and Construction

No changes in the emission factors.

Domestic Aviation

No changes in the emission factors.

Road Transportation

The emission factors for road transportation, diesel and gasoline, N₂O and CH₄, has been updated for the whole time series, 1990-2019. The update includes reporting emissions separately by vehicle category.

Domestic Navigation

The emission factors for diesel, CO₂, N₂O and CH₄, has been updated for 1990-2019.

Commercial/Institutional

No changes in the emission factors.

Residential

Emissions factors for CH₄ and N₂O have been corrected for the whole time series, 1990-2018.

Fishing

The emission factors for diesel, CO₂, N₂O and CH₄, has been updated for 1990-2019.

International bunkers

The emission factors for diesel, CO₂ has been updated for 1990-2019. Activity data for 2019 has been corrected.

International aviation

These emission factors for International aviation, Jet fuel, have been updated for CH₄ and N₂O, 1990-2019.

Industrial Processes and Product Use

Emissions from use of lubricants, paraffin wax and N₂O have been included for the first time. The estimates cover the entire time-series.

Agriculture

Emissions from fertilization of Agricultural soil and from Crop residues have been included for the first time. The estimates cover the entire time-series.

Waste

Emissions from landfills and wastewater treatment have been included for the first time in the present inventory.

Implications for emission levels

Most of the recalculations have only had small implication for the emissions levels.

Implications for emission trends, including time series consistency

No significant changes.

Improvements

As part of a project funded by the Danish Ministry for Climate, Energy and Utilities, several improvements have been included in this year's inventory and additional improvements are planned to be implemented in time for the 2023 submission.

The improvements carried out in this year's submission are:

- The reference approach has been reported for the first time
- The LULUCF sector has been included in the inventory
- The Agriculture sector now includes more emission categories

A number of improvements are planned for the 2023 submission:

- In the 2014 delivery, the recalculation made for fishing vessels, for certain reasons could only be done for the time-series 2001-2012. Therefore, the time series for fishing vessels, 2001-2019, is inconsistent with the time series 1990-2000. Oil sold to foreign fishing vessels for 1990-2000 will be estimated, and the activity data will be corrected correspondently.
- For agriculture data and emissions from horses and lamb will be included
- An uncertainty assessment using IPCC approach 1 will be included;
- Key categories will be described and discussed.

Annexes

All emissions factors used in the inventory are found in this Annex.

Annex 1.a. Emissions factors – Stationary combustion

The emissions factors used for calculating the Faroese emission of GHG in following stationary combustion categories are found in

Table 23.

- 1A1a Public Electricity and Heat Production
- 1A2 Manufacturing Industry and Construction
- 1A4a Commercial/Institutional
- 1A4b Residential

Table 23 Emission Factors for Stationary Combustion, 1990-2020.

Category	Fuel	Pollutant	1990-2006	2007-2020
Public Electricity and Heat Production	Gas/diesel oil	CH ₄ (g/GJ)	0.9	0.9
		CO ₂ (kg/GJ)	74.1	74.1
		N ₂ O (g/GJ)	0.4	0.4
	Heavy fuel oil	CH ₄ (g/GJ)	0.8	0.8
		CO ₂ (kg/GJ)	78.7	78.6-79.4
		N ₂ O (g/GJ)	0.3	0.3
Manufacturing Industries and Construction	Gas/diesel oil	CH ₄ (g/GJ)	0.2	0.2
		CO ₂ (kg/GJ)	74.1	74.1
		N ₂ O (g/GJ)	0.4	0.4
	Heavy fuel oil	CH ₄ (g/GJ)	1.3	1.3
		CO ₂ (kg/GJ)	78.7	78.6
		N ₂ O (g/GJ)	5	5
	Kerosene	CH ₄ (g/GJ)	3	3
		CO ₂ (kg/GJ)	71.9	71.9
		N ₂ O (g/GJ)	0.6	0.6
Commercial/Institutional	Gas/diesel oil	CH ₄ (g/GJ)	0.7	0.7
		CO ₂ (kg/GJ)	74.1	74.1
		N ₂ O (g/GJ)	0.4	0.4
	Kerosene	CH ₄ (g/GJ)	10	10
		CO ₂ (kg/GJ)	71.9	71.9
		N ₂ O (g/GJ)	0.6	0.6
Residential	Gas/diesel oil	CH ₄ (g/GJ)	0.7	0.7
		CO ₂ (kg/GJ)	74.1	74.1
		N ₂ O (g/GJ)	0.6	0.6
	Kerosene	CH ₄ (g/GJ)	10	10
		CO ₂ (kg/GJ)	71.9	71.9
		N ₂ O (g/GJ)	0.6	0.6

The emissions factors for calculating the Faroese emissions from the waste sector are found in Table 24.

Table 24 Emission factors for Waste Incineration, 1990-2020.

Year	Fossil Waste %	CO ₂ EMF-fossil kg/GJ	CO ₂ EMF-biogen kg/GJ	CH ₄ EMF-total g/GJ	N ₂ O EMF-total g/GJ
1990	32,2	37	86,7	0,59	1,2
1991	32,2	37	86,7	0,59	1,2
1992	35,4	37	84,2	0,59	1,2
1993	36,9	37	83	0,59	1,2
1994	36,9	37	83	0,59	1,2
1995	39,3	37	81,1	0,59	1,2
1996	41,2	37	79,6	0,59	1,2
1997	41,2	37	79,6	0,59	1,2
1998	41,2	37	79,6	0,59	1,2
1999	41,2	37	79,6	0,59	1,2
2000	41,2	37	79,6	0,59	1,2
2001	41,2	37	79,6	0,59	1,2
2002	41,2	37	79,6	0,59	1,2
2003	41,2	37	79,6	0,59	1,2
2004	41,2	37	79,6	0,51	1,2
2005	41,2	37	79,6	0,42	1,2
2006	41,2	37	79,6	0,34	1,2
2007	41,2	37	79,6	0,34	1,2
2008	41,2	37	79,6	0,34	1,2
2009	41,2	37	79,6	0,34	1,2
2010	41,2	37	79,6	0,34	1,2
2011	41,2	37,5	79,6	0,34	1,2
2012	41,2	40	79,6	0,34	1,2
2013	41,2	42,5	79,6	0,34	1,2
2014	41,2	42,5	79,6	0,34	1,2
2015	41,2	42,5	79,6	0,34	1,2
2016	41,2	42,5	79,6	0,34	1,2
2017	41,2	42,5	79,6	0,34	1,2
2018	41,2	42,5	79,6	0,34	1,2
2019	41,2	42,5	79,6	0,34	1,2
2020	41,2	42,5	79,6	0,34	1,2

Annex 1.b. Emissions factors – Mobile combustion

The emissions factors used for calculating the Faroese emission of GHG in following mobile combustion categories are found in Table 25, Table 26 and Table 27:

- 1A3a Domestic Aviation
- 1A3b Road Transportation
- 1A3d Domestic Navigation
- 1A4c Agriculture, Forestry and Fishing

Table 25 Emission factors for national aviation, 1990-2020.

	CH ₄ g/GJ	CO ₂ kg/GJ	N ₂ O g/GJ
1990	485,3	72	2,68
1991	485,3	72	2,68
1992	485,3	72	2,68
1993	485,3	72	2,68
1994	485,3	72	2,68
1995	485,3	72	2,68
1996	485,3	72	2,68
1997	485,3	72	2,68
1998	485,3	72	2,68
1999	485,3	72	2,68
2000	485,3	72	2,68
2001	0,13	72	2,58
2002	0,13	72	2,58
2003	0,13	72	2,58
2004	0,14	72	2,59
2005	0,15	72	2,63
2006	0,15	72	2,63
2007	0,16	72	2,64
2008	0,16	72	2,64
2009	0,16	72	2,64
2010	0,16	72	2,64
2011	0,15	72	2,63
2012	0,20	72	2,62
2013	0,23	72	2,61
2014	0,25	72	2,60
2015	0,26	72	2,59
2016	0,25	72	2,59
2017	0,23	72	2,55
2018	0,23	72	2,56
2019	0,23	72	2,55
2020	0,23	72	2,55

Table 26 Emission factors for Road Transportation, Example for diesel passenger cars, 1990-2020. EFs in g/km for urban and rural driving.

	Year	co2u_g_km	ch4u_g_km	n2ou_g_km	co2r_g_km	ch4r_g_km	n2or_g_km
Diesel PC	1990	234.0	0.022	0.000	130.2	0.012	0.000
Diesel PC	1991	237.0	0.021	0.000	131.6	0.012	0.000
Diesel PC	1992	235.1	0.021	0.000	133.8	0.012	0.000
Diesel PC	1993	237.9	0.021	0.000	135.3	0.012	0.001
Diesel PC	1994	235.5	0.021	0.000	136.9	0.011	0.001
Diesel PC	1995	236.0	0.021	0.001	138.3	0.011	0.001
Diesel PC	1996	238.8	0.020	0.001	139.9	0.011	0.001
Diesel PC	1997	234.6	0.020	0.001	141.9	0.010	0.002
Diesel PC	1998	234.8	0.017	0.001	144.2	0.009	0.002
Diesel PC	1999	232.1	0.015	0.001	146.2	0.008	0.003
Diesel PC	2000	228.9	0.014	0.002	147.3	0.007	0.004
Diesel PC	2001	229.5	0.012	0.003	148.0	0.006	0.004
Diesel PC	2002	223.2	0.010	0.006	147.5	0.005	0.004
Diesel PC	2003	220.2	0.009	0.007	146.9	0.004	0.004
Diesel PC	2004	215.1	0.008	0.009	146.3	0.003	0.004
Diesel PC	2005	216.5	0.007	0.010	145.9	0.003	0.004
Diesel PC	2006	214.7	0.006	0.011	145.7	0.002	0.004
Diesel PC	2007	211.7	0.005	0.012	145.0	0.001	0.004
Diesel PC	2008	211.0	0.004	0.014	142.9	0.001	0.004
Diesel PC	2009	205.7	0.003	0.014	140.6	0.001	0.004
Diesel PC	2010	208.6	0.003	0.014	139.0	0.001	0.004
Diesel PC	2011	197.9	0.002	0.015	135.7	0.000	0.004
Diesel PC	2012	199.9	0.002	0.015	135.6	0.000	0.004
Diesel PC	2013	198.4	0.001	0.015	134.3	0.000	0.004
Diesel PC	2014	194.8	0.001	0.015	134.4	0.000	0.004
Diesel PC	2015	195.2	0.001	0.015	133.0	0.000	0.004
Diesel PC	2016	196.2	0.001	0.015	132.7	0.000	0.004
Diesel PC	2017	198.2	0.001	0.014	133.5	0.000	0.004
Diesel PC	2018	200.4	0.000	0.014	135.2	0.000	0.004
Diesel PC	2019	204.5	0.000	0.014	136.9	0.000	0.004
Diesel PC	2020	204.5	0.000	0.014	136.9	0.000	0.004

Table 27 Emission factors for Domestic Navigation (diesel and residual) and Fisheries (diesel), 1990-2019.

	Navigation - diesel			Navigation and Fisheries - Residual			Fisheries - diesel		
	CH ₄ g/GJ	CO ₂ kg/GJ	N ₂ O g/GJ	CH ₄ g/GJ	CO ₂ kg/GJ	N ₂ O g/GJ	CH ₄ g/GJ	CO ₂ kg/GJ	N ₂ O kg/GJ
1990	1,545	74	1,852	1,632	78	1,932	1,519	74	1,874
1991	1,554	74	1,854	1,636	78	1,936	1,530	74	1,874
1992	1,562	74	1,855	1,637	78	1,936	1,541	74	1,874
1993	1,562	74	1,855	1,632	78	1,935	1,553	74	1,874
1994	1,566	74	1,855	1,619	78	1,930	1,565	74	1,874
1995	1,580	74	1,854	1,621	78	1,930	1,578	74	1,874
1996	1,648	74	1,857	1,631	78	1,925	1,592	74	1,874
1997	1,594	74	1,860	1,657	78	1,917	1,606	74	1,874
1998	1,604	74	1,861	1,693	78	1,923	1,622	74	1,874
1999	1,589	74	1,864	1,709	78	1,922	1,639	74	1,874
2000	1,664	74	1,867	1,725	78	1,924	1,656	74	1,874
2001	1,671	74	1,867	1,746	78	1,928	1,673	74	1,874
2002	1,710	74	1,867	1,773	78	1,934	1,689	74	1,874
2003	1,698	74	1,868	1,805	78	1,934	1,704	74	1,874
2004	1,678	74	1,867	1,811	78	1,930	1,718	74	1,874
2005	1,685	74	1,869	1,854	78	1,942	1,731	74	1,874
2006	1,673	74	1,868	1,886	78	1,950	1,743	74	1,874
2007	1,673	74	1,867	1,898	78	1,950	1,753	74	1,874
2008	1,697	74	1,868	1,905	78	1,950	1,762	74	1,874
2009	1,700	74	1,868	1,918	78	1,949	1,770	74	1,874
2010	1,691	74	1,868	1,927	78	1,949	1,775	74	1,874
2011	1,663	74	1,868	1,936	78	1,949	1,780	74	1,874
2012	1,783	74	1,868	1,945	78	1,949	1,785	74	1,874
2013	1,816	74	1,868	1,954	78	1,949	1,791	74	1,874
2014	1,794	74	1,867	1,962	78	1,949	1,797	74	1,874
2015	1,803	74	1,868	1,957	78	1,946	1,803	74	1,874
2016	1,799	74	1,869	1,962	78	1,946	1,810	74	1,874
2017	1,843	74	1,869	1,974	78	1,947	1,817	74	1,874
2018	1,829	74	1,869	1,980	78	1,947	1,823	74	1,874
2019	1,741	74	1,868	2,004	78	1,949	1,828	74	1,874

Annex 8 - Key category analysis for Denmark and Greenland

The KCAs for Denmark and Greenland includes six KCAs shown in Table A8-1 – A8-6 below.

Table A8-1 KCA for Denmark+Greenland, level assessment, base year excl. LULUCF.

This table is available at: <https://envs.au.dk/en/faglige-omraader/luftforurening-udledninger-og-effekter/udledning-af-luftforurening/greenhouse-gases/supporting-documentation>

Table A8-2 KCA for Denmark+Greenland, level assessment, base year incl. LULUCF.

This table is available at: <https://envs.au.dk/en/faglige-omraader/luftforurening-udledninger-og-effekter/udledning-af-luftforurening/greenhouse-gases/supporting-documentation>

Table A8-3 KCA for Denmark+Greenland, level assessment, 2020 excl. LULUCF.

This table is available at: <https://envs.au.dk/en/faglige-omraader/luftforurening-udledninger-og-effekter/udledning-af-luftforurening/greenhouse-gases/supporting-documentation>

Table A8-4 KCA for Denmark+Greenland, level assessment, 2020 incl. LULUCF.

This table is available at: <https://envs.au.dk/en/faglige-omraader/luftforurening-udledninger-og-effekter/udledning-af-luftforurening/greenhouse-gases/supporting-documentation>

Table A8-5 KCA for Denmark+Greenland, trend assessment 1990-2020, excl. LULUCF.

This table is available at: <https://envs.au.dk/en/faglige-omraader/luftforurening-udledninger-og-effekter/udledning-af-luftforurening/greenhouse-gases/supporting-documentation>

Table A8-6 KCA for Denmark+Greenland, trend assessment 1990-2020, incl. LULUCF.

This table is available at: <https://envs.au.dk/en/faglige-omraader/luftforurening-udledninger-og-effekter/udledning-af-luftforurening/greenhouse-gases/supporting-documentation>

Annex 9 - Comparison of fuel data from Eurostat and CRF

As part of the EU review of the reported GHG emission data, EU performs for each member state a comparison of Eurostat energy data in terms of TJ with energy data provided in the CRF. The comparison has been performed in accordance with the Commission implementing regulation (EU) No 749/2014 of 30 June 2014 and with the IPCC Guidelines (2006). The comparison includes comparisons of the reference approach (RA) and the sectoral approach (SA) for the years 2005 and 2008-2020.

In Denmark, the emission inventory is based on the energy statistics published by the Danish Energy Agency (DEA). DEA is responsible for the reporting to Eurostat.

Reference approach, comparison of CRF and Eurostat data

The apparent fuel consumption reported in the CRF reference approach has been compared to data aggregated from Eurostat as part of the EU internal review for the EU-GHG inventory. The results are shown in Table A9-1. Fuel consumption differences for all years (2005 and 2008-2020) are shown in Table A9-2.

The fossil fuel consumption stated in CRF for 2020 differs 4141 TJ or 1.1 % from the fossil fuel consumption based on the Eurostat data. The differences are -98 TJ (-0.3 %) for solid fuels, 4235 TJ (1.8 %) for liquid fuels, 4 TJ (0.0 %) for gaseous fuels, and 0 TJ for fossil waste (0 %).

Solid fuels

The Danish energy statistics include two different types of coal in the fuel category Other bituminous coal; Electricity plant coal and Other hard coal. The LCV reported to Eurostat in the category “Used for main activity plants (net)” is the LCV for Electricity plant coal. However, a small amount of Other hard coal is also applied in these plants. Thus, the Eurostat data includes a small deviation fuel consumption for 2016-2020.

Liquid fuels

The apparent consumption differs 4235 TJ for liquid fuels, 2020. The fuels with large differences are gas-/diesel oil (8236 TJ), residual fuel oil (4368 TJ) and jet kerosene (369 TJ). In addition, the apparent consumption of white spirit (350 TJ) has been included in the fuel category Other liquid in the Danish CRF whereas the consumption has been included in Other oil in the EU compare file.

Fuel consumption for transport between mainland Denmark and Greenland and the Faroe Islands is not included in the reporting to the IEA and Eurostat. In the Danish emission inventory, the transport between Denmark, Greenland and the Faroe Islands is considered domestic. This causes a difference for liquid fuels used for aviation and navigation.

For jet kerosene, a considerable difference between CRF and Eurostat data all years is related to the fuel consumption to/from Greenland or the Faroe Islands. The consumption of jet kerosene between Denmark, Greenland and the Faroe Islands was 369 TJ in 2020. The difference for consumption of jet kerosene was 369 TJ in the 2020 data set.

For diesel oil, the difference between the apparent consumption in the two data sets is 8236 TJ for 2020. The fuel consumption to/from Greenland or the Faroe Islands was 445 TJ in 2020. In addition, the Eurostat data for stock change have not been reported correctly by the Danish Energy Agency for the fuel category *Non-bio gasdiesel oil*. The Danish Energy Agency have confirmed that biodiesel is included in the reported data for stock change and that the Eurostat data will be corrected (Zarnaghi, 2021). This cause a 937 TJ difference for 2020. For the years until 2014 data also differ for import and export between CRF and Eurostat due to inconsistency of the international reporting. Finally, a 5638 TJ difference is related to an error in the data for international bunkers reported in the January version of CRF. This has been corrected in the CRF reported in March.

For residual oil, the difference between the two data sets is 4368 TJ for 2020. The data for import, export and stock change are in agreement whereas the data for international bunkers differ considerably. For other years than 2020, the difference in data for international bunkers is almost equal to the fuel consumption to/from Greenland or Faroe Islands. For 2020, the difference in data for international bunkers is 4368 TJ. The fuel consumption to/from Greenland or Faroe Islands was 1270 TJ in 2020. The remaining difference (5638 TJ) is related to an error in the January version of CRF that have been corrected in the CRF reported in March.

For gasoline, the apparent fuel consumption differs all years, however the difference is low for later years and thus for 2020 the difference is only 4 TJ. The data for export and international bunkers are almost equal whereas the import differ considerably for the years before 2013. In addition, stock change differs for some years. The data in CRF are in agreement with the [Danish energy statistics](#). The inconsistency of the international reporting is part of an ongoing dialogue with the Danish Energy Agency and the data will be corrected by the Danish Energy Agency if relevant.

For crude oil, the relatively large difference in 2005 (326 TJ) is due to implementation of waste oil in the fuel category crude oil in the CRF reference approach. The consumption of waste oil was lower in 2008-2020.

DCE reports white spirit in the CRF fuel category Other liquid fossil, whereas the aggregation based on data from Eurostat includes white spirit in the fuel category Other oil.

Gaseous fuels

Differences in apparent consumption are below 5 TJ for gaseous fuels all years.

Waste

The data for waste are equal in the two data sets.

Biomass

Data for apparent consumption of solid biomass consumption are equal in 2010-2020. However, for the years 2005 and 2008-2009 the CRF and Eurostat data differ up to 1800 TJ. The Eurostat data for primary production of solid biofuels include production of bio oil for the years 2005 and 2008-2009. The data are expected to be revised before 2023 as this difference is part of the ongoing dialogue with the Danish Energy Agency.

For liquid biomass the difference between the two data sets is small for 2016-2019. For 2005 and 2008-2015, the difference is between -59 TJ - 513 TJ. This is mainly due to implementation of bio oil in the fuel category primary solid biofuels in the data reported to Eurostat for these years. The inconsistency of the international reporting is part of an ongoing dialogue with the Danish Energy Agency and the data will be corrected by the Danish Energy Agency if relevant.

Data for apparent consumption of gaseous biomass do not differ considerably.

Table A9-1 Comparison of apparent consumption in 2020 (EU, 2022).

CRF Fuel Group	CRF Fuel Name	2020 Eurostat, TJ	2020 Crf, TJ	2020 Difference, TJ	2020 Difference, %
solid	Anthracite	--	--	0	0.0%
solid	BKB and patent fuel	--	--	0	0.0%
solid	Coal tar	--	--	0	0.0%
solid	Coke oven/gas coke	90	90	0	0.0%
solid	Coking coal	--	--	0	0.0%
solid	Lignite	--	--	0	0.0%
solid	Oil shale and tar sand	--	--	0	0.0%
solid	Other bituminous coal	29,731	29,633	-98	-0.3%
solid	Other solid	--	--	0	0.0%
solid	Sub-bituminous coal	--	--	0	0.0%
solid	Total solid	29,820	29,723	-98	-0.3%
liquid	Bitumen	6,959	6,959	0	0.0%
liquid	Crude oil	303,799	303,801	2	0.0%
liquid	Ethane	--	--	0	0.0%
liquid	Gas/diesel oil	-2,584	5,652	8,236	-318.8%
liquid	Gasoline	-33,168	-33,172	-4	0.0%
liquid	Jet kerosene	-1,006	-637	369	-36.7%
liquid	Liquefied petroleum gas (lpg)	-2,588	-2,588	0	0.0%
liquid	Lubricants	2,150	2,150	0	0.0%
liquid	Naphta	--	--	0	0.0%
liquid	Natural gas liquids	--	--	0	0.0%
liquid	Orimulsion	--	--	0	0.0%
liquid	Other kerosene	--	--	0	0.0%
liquid	Other liquid	--	350	350	0.0%
liquid	Other oil	350	--	-350	-100.0%
liquid	Petroleum coke	7,868	7,868	0	0.0%
liquid	Refinery feedstocks	342	342	0	0.0%
liquid	Residual fuel oil	-53,094	-57,461	-4,368	8.2%
liquid	Shale oil	--	--	0	0.0%
liquid	Total liquid	229,029	233,264	4,235	1.8%
gaseous	Natural gas	88,435	88,439	4	0.0%
gaseous	Other gaseous	--	--	0	0.0%
gaseous	Total gaseous	88,435	88,439	4	0.0%
waste	Waste	18,723	18,723	0	0.0%
biomass	Solid biomass	125,302	125,302	0	0.0%
biomass	Liquid biomass	10,132	10,132	0	0.0%
biomass	Gas biomass	21,379	21,379	0	0.0%
biomass	Other biomass	22,884	22,884	0	0.0%
biomass	Total biomass	179,696	179,697	0	0.0%
All	Total	366,008	370,149	4,141	1.1%

Table A9-2 Comparison of apparent consumption (EU, 2022).

CRF Fuel Name	2005	2008	2009	2010	2011	2012	2013	2014	2015	2016	2017	2018	2019	2020
	Difference	Difference	Difference	Difference	Difference	Difference	Difference	Difference	Difference	Difference	Difference	Difference	Difference	Difference
	TJ	TJ	TJ	TJ	TJ	TJ	TJ	TJ	TJ	TJ	TJ	TJ	TJ	TJ
Anthracite	0	0	0	0	0	0	0	0	0	0	0	0	0	0
BKB and patent fuel	-6	-6	-7	-9	2	-3	0	0	-1	0	0	0	0	0
Coal tar	0	0	0	0	0	0	0	0	0	0	0	0	0	0
Coke oven/gas coke	6	15	-10	23	-25	-17	10	-2	0	0	0	0	0	0
Coking coal	0	0	0	0	0	0	0	0	0	0	0	0	0	0
Lignite	0	0	0	0	0	0	0	0	0	0	0	0	0	0
Oil shale and tar sand	0	0	0	0	0	0	0	0	0	0	0	0	0	0
Other bituminous coal	10	29	1	-11	-23	2	-48	-20	0	-934	1054	204	226	-98
Other solid	0	0	0	0	0	0	0	0	0	0	0	0	0	0
Sub-bituminous coal	0	0	0	0	0	0	0	0	0	0	0	0	0	0
Total solid	11	39	-16	3	-46	-18	-38	-22	-1	-934	1054	203	226	-98
Bitumen	7	17	-37	-15	1	-8	20	-17	-1	0	0	0	0	0
Crude oil	326	88	42	-8	60	71	38	-46	37	19	19	3	3	2
Ethane	0	0	0	0	0	0	0	0	0	0	0	0	0	0
Gas/diesel oil	248	-1625	-7293	-379	-2206	-5508	224	-233	327	183	925	402	555	8236
Gasoline	-197	-731	8015	-1788	-3008	-2999	-54	278	-10	-408	149	-1024	-13	-4
Jet kerosene	809	747	632	609	582	584	540	488	487	511	607	691	720	369
Liquefied petroleum gas (lpg)	-25	-40	-79	32	46	-121	2	145	0	0	0	0	0	0
Lubricants	-37	31	-8	13	13	13	13	13	0	0	0	0	0	0
Naphta	-3	70	8	-23	-22	0	0	0	0	0	0	0	0	0
Natural gas liquids	0	0	0	0	0	0	0	0	0	0	0	0	0	0
Orimulsion	0	0	0	0	0	0	0	0	0	0	0	0	0	0
Other kerosene	0	0	0	0	0	0	0	0	0	18	19	0	0	0
Other liquid	849	351	407	382	383	411	452	358	319	357	269	261	335	350
Other oil	-870	-348	-392	-392	-392	-392	-479	-348	-319	-357	-269	-261	-335	-350
Petroleum coke	5	-20	29	-3	-2	30	-48	-8	13	0	0	0	0	0
Refinery feedstocks	-390	36	29	-27	2160	114	-750	40	7	0	0	0	0	0
Residual fuel oil	1132	1420	1530	1500	1521	1700	2426	1551	1534	1550	1739	1509	1019	-4368
Shale oil	0	0	0	0	0	0	0	0	0	0	0	0	0	0
Total liquid	1853	-6	2883	-95	-863	-6105	2385	2224	2394	1874	3458	1581	2283	4235
Natural gas	-3	-3	-2	0	-2	-2	2	0	4	2	3	2	4	4
Other gaseous	0	0	0	0	0	0	0	0	0	0	0	0	0	0
Total gaseous	-3	-3	-2	0	-2	-2	2	0	4	2	3	2	4	4
Waste	0	0	0	0	0	0	0	0	0	0	0	0	0	0

CRF Fuel Name	2005 Difference TJ	2008 Difference TJ	2009 Difference TJ	2010 Difference TJ	2011 Difference TJ	2012 Difference TJ	2013 Difference TJ	2014 Difference TJ	2015 Difference TJ	2016 Difference TJ	2017 Difference TJ	2018 Difference TJ	2019 Difference TJ	2020 Difference TJ
Solid biomass	-760	-1794	-1622	0	0	0	0	0	0	0	0	0	0	0
Liquid biomass	200	484	411	513	174	210	274	-59	71	0	-4	-3	-2	0
Gas biomass	0	0	4	0	0	0	0	0	0	0	6	0	0	0
Other biomass	0	0	0	0	0	0	0	0	-1	0	1	0	0	0
Total biomass	-560	-1310	-1207	513	174	210	274	-59	70	0	3	-3	-2	0
Other fossil fuels	0	0	0	0	0	0	0	0	0	0	0	0	0	0
Peat	0	0	0	0	0	0	0	0	0	0	0	0	0	0
Total	1862	31	2865	-92	-910	-6125	2348	2202	2397	943	4516	1786	2513	4141

Sectoral approach, comparison of CRF and Eurostat data

The difference between the fuel consumption in the national approach of CRF have been compared to fuel consumption data from Eurostat for 2005 and 2008-2020.

Table A9-3 shows the fuel consumptions and differences between fuel consumption data from CRF and Eurostat for 2020. Table A9-4 shows the differences between the fuel consumption data in CRF and Eurostat for 2005 and 2008-2020.

The 2020 fossil fuel consumption is 354 TJ (0.1 %) lower in CRF than the data aggregated based on the Eurostat data. The difference in fossil fuel consumption is between 0.0 % and 2.5 % for 2005 and 2008-2020. Except for 2020, the fuel consumption reported in CRF is higher than the Eurostat fuel consumption data. This is due to the inclusion of fuel consumption to/from Greenland or Faroe Islands in domestic consumption in CRF.

The 2020 fuel consumption for solid fuels is 46 TJ higher in the CRF data than in the Eurostat data, corresponding to 0.1%. This difference is related to the implementation of plant specific data in the CRF national approach.

The 2020 fuel consumption for liquid fuels is 10129 TJ higher in CRF than in the Eurostat data, corresponding to 4.7% higher.

For liquid fuels, the domestic consumption jet kerosene, gas / diesel oil and residual oil reported to Eurostat is lower than in CRF. The fuel consumption for transport between mainland Denmark and Greenland and the Faroe Islands is included in international bunkers in the reporting to Eurostat. In the Danish emission inventory, the transport between Denmark, Greenland and the Faroe Islands is considered domestic. This causes a difference for liquid fuels used for aviation and navigation. In 2020, this cause a 1270 TJ difference for fuel oil and a 445 TJ difference for diesel oil.

The border trade motor gasoline (1643 TJ in 2020) and diesel oil (12195 TJ in 2020) is included in CRF but not in the consumption rates for road transport in the Eurostat-data.

Finally, the Danish Energy Agency have confirmed an error in the international reporting of fossil diesel oil. The reported data for road transport includes biodiesel. The DEA have confirmed that this will be corrected (Zarnaghi, 2022).

For gaseous fuels, the 2020 fuel consumption in CRF is 11801 TJ lower than the Eurostat data, corresponding to 12.1 %. The Eurostat data for gaseous fuels includes biogas upgraded for distribution in the natural gas grid (bio natural gas or bio methane). The consumption of this fuel added up to 13481 TJ in 2020. In CRF, this fuel consumption is included in the fuel category biomass. In addition, the gaseous fuel consumption for offshore gas turbines is higher in CRF than in the Eurostat data. CRF data for offshore gas turbines is based on EU ETS data that are not in agreement with the energy statistics due to application of an inaccurate NCV in the energy statistics. Thus, the natural gas consumption in the energy statistics and in the Eurostat-data are 1746 TJ lower for Oil and gas extraction than reported in CRF for 2020.

For fossil waste, the 2020 consumption in the CRF data are 1272 TJ or 6.8 % higher than in the Eurostat data. The fossil part of waste is plant-specific for some plants in the CRF data whereas a fixed fossil energy part is applied in the energy statistics. The fossil part of waste applied in the cement production plant differ from the fossil part of municipal waste applied in Denmark.

For biomass, the 2020 consumption in the CRF data are 12273 TJ or 7.4 % higher than in the CRF data. Bio natural gas has been reported in the fuel category biomass in CRF whereas it has been included in gaseous fuels in the Eurostat data. This cause a 13481 TJ lower fuel consumption in the 2020 Eurostat data. The large increase of bio natural gas in the Danish gas grid is reflected in the time series in Table A9-4. In addition, the biogenic part of waste is plant-specific for some plants in the CRF data whereas a fixed fossil energy part is applied in the energy statistics.

Table A9-3 Total fuel consumption, sectoral approach, 2020 (EU, 2022).

	Fuel Eurostat, TJ	Fuel CRF, TJ	Difference, TJ	Difference, %
Solid	33,266	33,312	46	0.1%
Liquid	215,452	225,581	10,129	4.7%
Gaseous	97,550	85,749	-11,801	-12.1%
Other fossil	18,723	19,995	1,272	6.8%
Biomass	165,709	177,982	12,273	7.4%
Fossil fuels	364,991	364,636	-354	-0.10%

Table A9-4 Fuel consumption difference between CRF national approach and Eurostat data (EU, 2022).

	2005	2008	2009	2010	2011	2012	2013	2014	2015	2016	2017	2018	2019	2020
Solid, TJ	131	104	44	58	24	119	73	117	49	79	146	37	25	46
Liquid, TJ	2272	1857	2503	2488	1563	8849	9428	10241	7148	8890	12313	12324	11176	10129
Gaseous, TJ	10	1067	842	1211	1401	959	1573	383	-1024	-1612	-5803	-6321	-8293	-11801
Other, TJ	-172	222	305	160	437	508	739	707	840	1098	951	1162	1147	1272
Biomass, TJ	-385	-1573	-1558	321	-218	-385	-557	-433	134	2404	4235	5955	8331	12273
Fossil, TJ	2241	3250	3693	3918	3425	10435	11813	11448	7013	8455	7608	7203	4056	-354
Fossil, %	0.7%	0.5%	1.8%	2.0%	1.9%	1.2%	1.8%	2.1%	2.5%	1.8%	1.7%	0.0%	0.0%	0.0%

References

EU, 2022: EU GHG Comparison Eurostat data with CRF data, EC22_Eurostat_Crf_Compare_TJ Jan.

Zarnaghi, 2021: Email from Ali Zarnaghi, The Danish Energy Agency, 09-03-2021.

Zarnaghi, 2022: Email from Ali Zarnaghi, The Danish Energy Agency, 10-03-2022.

DENMARK'S NATIONAL INVENTORY REPORT 2022

Emission Inventories 1990-2020 – Submitted under the United Nations Framework Convention on Climate Change and the Kyoto Protocol

This report is Denmark's National Inventory Report 2022, which serves as documentation for the Danish greenhouse gas inventories submitted to the European Union and the United Nations. The report contains information on Denmark's emission inventories for all years' from 1990 to 2020 for CO₂, CH₄, N₂O, HFCs, PFCs and SF₆.