



**KEMENTERIAN PERHUBUNGAN
DIREKTORAT JENDERAL PERKERETAAPIAN**

GEDUNG KARYA
JL. MEDAN MERDEKA BARAT N08
JAKARTA 10110

TEL : (021) 3506204 , 385683
3505557, 3505558
3505559, 3506526

Fax : (021) 350620 4,
3813972

KEPUTUSAN DIREKTUR JENDERAL PERKERETAAPIAN

NOMOR : KP-DJKA 68 TAHUN 2023

T E N T A N G

**GRAFIK PERJALANAN KERETA API
PADA JARINGAN JALUR KERETA API NASIONAL DI
SUMATERA BAGIAN UTARA TAHUN 2023**

DIREKTUR JENDERAL PERKERETAAPIAN,

- Menimbang : a. bahwa untuk melaksanakan ketentuan Pasal 29 Peraturan Menteri Perhubungan Nomor PM. 110 Tahun 2017 tentang Tata Cara dan Standar Pembuatan Grafik Perjalanan Kereta Api, Perjalanan Kereta Api di Luar Grafik Perjalanan Kereta Api, dan Perjalanan Kereta Api Luar Biasa, perlu menetapkan grafik perjalanan kereta api pada jaringan jalur kereta api nasional di Sumatera Bagian Utara tahun 2023;
- b. bahwa dengan adanya perubahan kebutuhan angkutan, perubahan kondisi prasarana, dan peningkatan kecepatan kereta api, perlu untuk menyesuaikan jadwal dan frekuensi perjalanan kereta api pada jaringan jalur kereta api nasional di Sumatera Bagian Utara;
- c. bahwa berdasarkan pertimbangan sebagaimana dimaksud dalam huruf a dan huruf b, perlu menetapkan Keputusan Direktur Jenderal Perkeretaapian tentang Grafik Perjalanan Kereta Api Pada Jaringan Jalur Kereta Api Nasional di Sumatera Bagian Utara Tahun 2023;
- Mengingat : 1. Undang-undang Nomor 23 Tahun 2007 tentang Perkeretaapian (Lembaran Negara Tahun 2007 Nomor 65, Tambahan Lembaran Negara Nomor 4722);

2. Peraturan Pemerintah Nomor 56 Tahun 2009 tentang Penyelenggaraan Perkeretaapian sebagaimana telah diubah dengan Peraturan Pemerintah Nomor 6 Tahun 2017 tentang Perubahan atas Peraturan Pemerintah Nomor 56 Tahun 2009 tentang Penyelenggaraan Perkeretaapian (Lembaran Negara Tahun 2017 Nomor 29, Tambahan Lembaran Negara Nomor 6022);
3. Peraturan Pemerintah Nomor 72 Tahun 2009 tentang Lalu Lintas dan Angkutan Kereta Api sebagaimana telah diubah dengan Peraturan Pemerintah Nomor 61 Tahun 2016 tentang Perubahan Atas Peraturan Pemerintah Nomor 72 Tahun 2009 tentang Lalu Lintas dan Angkutan Kereta Api (Lembaran Negara Tahun 2016 Nomor 264, Tambahan Lembaran Negara Nomor 5961);
4. Peraturan Menteri Perhubungan Republik Indonesia Nomor PM. 110 Tahun 2017 tentang Tata Cara Dan Standar Pembuatan Grafik Perjalanan Kereta Api, Perjalanan Kereta Api Di Luar Grafik Perjalanan Kereta Api, Dan Perjalanan Kereta Api Luar Biasa;
5. Peraturan Menteri Perhubungan Republik Indonesia Nomor PM. 17 Tahun 2022 tentang Organisasi dan Tata Kerja Kementerian Perhubungan (Berita Negara Republik Indonesia Tahun 2022 Nomor 815);

MEMUTUSKAN :

Menetapkan : KEPUTUSAN DIREKTUR JENDERAL PERKERETAAPIAN TENTANG GRAFIK PERJALANAN KERETA API PADA JARINGAN JALUR KERETA API NASIONAL DI SUMATERA BAGIAN UTARA TAHUN 2023.

KESATU : Menetapkan dan mengumumkan rencana perjalanan kereta api sesuai dengan Grafik Perjalanan Kereta Api (Gapeka) Pada Jaringan Jalur Kereta Api Nasional di Sumatera Bagian Utara sebagaimana tercantum dalam Lampiran I yang merupakan bagian tidak terpisahkan dari Keputusan ini, dengan pendukung yang terdiri atas:

1. Buku penomoran kereta api kapasitas lintas dan jarak antar stasiun sebagaimana tercantum dalam Lampiran II yang merupakan bagian tidak terpisahkan dari Keputusan ini;

2. Buku perjalanan kereta api sebagaimana tercantum dalam Lampiran III yang merupakan bagian tidak terpisahkan dari Keputusan ini;
3. Buku dukungan sarana perkeretaapian sebagaimana tercantum dalam Lampiran IV yang merupakan bagian tidak terpisahkan dari Keputusan ini.

KEDUA

: PT. Kereta Api Indonesia (Persero) selaku pelaksana penyelenggara prasarana perkeretaapian milik negara, mengoperasikan prasarana perkeretaapian di Sumatera Bagian Utara melalui serangkaian kegiatan pengaturan dan pengendalian perjalanan kereta api sesuai dengan Gapeka sebagaimana ditetapkan dalam Keputusan ini, dengan ketentuan sebagai berikut:

- a. Melakukan sosialisasi kepada masyarakat sebelum pemberlakuan Gapeka;
- b. Melaporkan pelaksanaan Gapeka secara periodik;
- c. Apabila terdapat perubahan rencana perjalanan kereta api yang tercantum di dalam Gapeka maupun rencana perjalanan kereta api baru, maka penetapan dan pengumuman perjalanan kereta api dilakukan sesuai dengan ketentuan peraturan perundang-undangan yang mengatur mengenai perjalanan kereta api di luar Gapeka yang persetujuannya ditandatangani oleh Direktur Lalu Lintas dan Angkutan Kereta Api;
- d. Melakukan evaluasi terhadap pelaksanaan Gapeka bersama dengan Direktorat Jenderal Perkeretaapian paling sedikit 1 (satu) kali setiap 3 (tiga) bulan;
- e. Mengembangkan aplikasi sistem pelaporan pelaksanaan Gapeka berbasis website bersama dengan Direktorat Jenderal Perkeretaapian untuk mewujudkan Sistem Pemerintahan Berbasis Elektronik (SPBE).

KETIGA

: Laporan pelaksanaan Gapeka secara periodik sebagaimana Diktum KEDUA huruf b, meliputi:

- a. Laporan Mingguan, paling lambat setiap hari Selasa minggu berikutnya;
- b. Laporan Bulanan, paling lambat setiap tanggal 10 (sepuluh) bulan berikutnya;
- c. Laporan Tahunan, paling lambat setiap tanggal 20 (dua puluh) pada bulan Januari tahun berikutnya.

KEEMPAT : Laporan Mingguan, Bulanan, dan Tahunan sebagaimana dimaksud pada Diktum KETIGA paling sedikit memuat:

- a. realisasi waktu kelambatan perjalanan tiap kereta api;
- b. realisasi ketepatan perjalanan tiap kereta api;
- c. realisasi frekuensi perjalanan kereta api;
- d. kejadian kecelakaan kereta api (KKA) dan kejadian non-kecelakaan kereta api (NKKA) dan penanganannya;
- e. perubahan perjalanan kereta api;
- f. persentase ketepatan perjalanan kereta api;
- g. penyebab kelambatan perjalanan kereta api;
- h. pemindahan persilangan dan penyusulan perjalanan kereta api;
- i. realisasi kilometer tempuh tiap-tiap kereta api (KM-KA) dan *gross-ton* kereta api (GT-KA).

KELIMA : PT. Kereta Api Indonesia (Persero) dan PT. Railink selaku badan usaha penyelenggara sarana perkeretaapian, mengoperasikan sarana perkeretaapian di Sumatera Bagian Utara sesuai dengan Gapeka sebagaimana ditetapkan dalam Keputusan ini, dengan ketentuan sebagai berikut:

- a. Melakukan sosialisasi kepada masyarakat sebelum pemberlakuan Gapeka;
- b. Apabila terdapat perubahan rencana perjalanan kereta api yang tercantum di dalam Gapeka maupun rencana perjalanan kereta api baru, maka penetapan dan pengumuman perjalanan kereta api dilakukan sesuai dengan ketentuan peraturan perundang-undangan yang mengatur mengenai perjalanan kereta api di luar Gapeka;
- c. Apabila diperlukan, dapat melakukan perhitungan secara *self-assessment* terhadap biaya penggunaan prasarana perkeretaapian milik negara di Sumatera Bagian Utara berdasarkan Gapeka sebagaimana ditetapkan dalam Keputusan ini.

KEENAM : Rencana perjalanan kereta api sesuai dengan Gapeka sebagaimana ditetapkan dalam Keputusan ini, dilaksanakan mulai tanggal 1 Juni 2023.

- KETUJUH : Direktur Lalu Lintas dan Angkutan Kereta Api dan Kepala Balai Teknik Perkeretaapian melakukan pengawasan terhadap pelaksanaan Gapeka sebagaimana ditetapkan dalam Keputusan ini.
- KEDELAPAN : Pelaksanaan pengawasan sebagaimana Diktum KETUJUH, dapat melibatkan pakar, akademisi, dan/atau tenaga ahli sesuai dengan kebutuhan.
- KESEMBILAN : Apabila dikemudian hari dinyatakan terdapat kekeliruan dalam Keputusan ini, maka akan diadakan perbaikan sebagaimana mestinya.
- KESEPULUH : Keputusan ini mulai berlaku sejak tanggal ditetapkan.

Ditetapkan di : J A K A R T A

Pada tanggal : 14 April 2023

DIREKTUR JENDERAL PERKERETAAPIAN

ttd.

Ir. MOHAMAD RISAL WASAL, ATD., MM., IPM

Pembina Utama Madya (IV/d)

NIP. 19670608 199003 1 005

Salinan Keputusan ini disampaikan kepada Yth.:

1. Menteri Perhubungan;
2. Sekretaris Jenderal Kementerian Perhubungan;
3. Inspektur Jenderal Kementerian Perhubungan;
4. Para Direktur di lingkungan Direktorat Jenderal Perkeretaapian;
5. Direktur Utama PT. Kereta Api Indonesia (Persero);
6. Direktur Utama PT. Railink.

Salinan sesuai dengan aslinya
KEPALA BAGIAN HUKUM

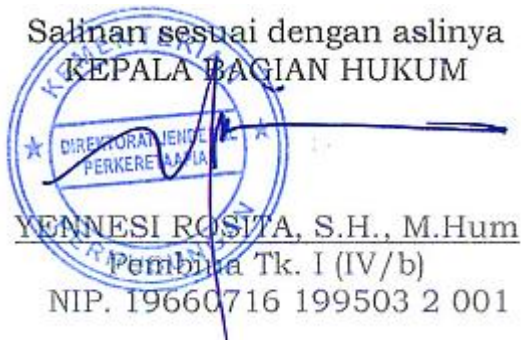

YENNESI ROSITA, S.H., M.Hum

Pembina Tk. I (IV/b)

NIP. 19660716 199503 2 001

LAMPIRAN I KEPUTUSAN DIREKTUR JENDERAL
PERKERETAAPIAN

NOMOR : KP-DJKA 68 TAHUN 2023

TANGGAL : 14 APRIL 2023



**GRAFIK PERJALANAN KERETA API
JARINGAN JALUR KERETA API NASIONAL DI
SUMATERA BAGIAN UTARA**

**KEMENTERIAN PERHUBUNGAN
DIREKTORAT JENDERAL PERKERETAAPIAN
JAKARTA 2023**



UJUNG BARU - MEDAN - ARASKABU - TEBING TINGGI - BANDAR TINGGI - KISARAN - RANTAU PRAPAT
MEDAN - BESITANG
MEDAN - BANDAR KALIPAH
ARASKABU - KUALANAMU
TEBING TINGGI - SIANTAR
BANDAR TINGGI - KUALA TANJUNG
KISARAN - TANJUNG BALAI - SSP TELUK NIBUNG
KRUENGGUKUEH - KRUENGMANE - KUTABLANG

1B
08.00-16.00

Yang berhak mengumumkan perjalanan kereta api
Ksb Mdn untuk lintas : Mdn-Biw, Mdn-Knm, Mdn-Tbi, Mdn-Bsg
Ks Tbi untuk lintas : Tbi-Sir, Tbi-Kis, Tbi-Kj
Ksb Kis untuk lintas : Kis-Tnb, Kis-Rap

JALUR GANDA
MDN - BAP
BAP - ARB
ARB - KNM

Berlaku mulai tanggal 1 Juni 2023

(Waktu Indonesia Barat)

Stasiun	08.00	09.00	10.00	11.00	12.00	13.00	14.00	15.00	16.00
Ujung Baru									
Belawan									
Labuan									
Kampung Harau									
Titi Papan									
Sip Caya Brada Bayu									
Palu Brayau									
Medan									
Medan Pasar									
Kecua Pungur									
Bandar Kalipah									
Batang Kuis									
Sindang									
Araskabu									
Pasar Sani									
Lubuk Pakam									
Perbaungan									
Lidah Tanah									
Ibu									
Teluk Mengkudu									
Rampah									
Bamban									
Batubara									
Tebing Tinggi									
Pasar Pening									
Mendut									
Laui Tador									
Tanjung Kuro									
Bandar Tinggi									
Paritbatan									
Bahilau									
Perlanjau									
Sip Linau Baru									
Lima Puluh									
Sip Linau Manis									
Dusun									
Saibjanjau									
Sip Hant									
Bumai									
Kisaran									
Sorang									
Sip Aian									
Sipah									
Hengelo									
Teluk Dalam									
Mauit									
Pulau									
Aekloba									
Membang Mada									
Geumpang									
Sitangin									
Tanah Gajah									
Adianjaya									
Kp. Adianjaya									
Panienke									
Palang Halahan									
Sip P. Siantar									
Marbau									
Bahau Selatan									
Sip Malar									
Sip Aek Pala									
Rantau Prapat									
Medan									
Sorang									
Sip Sevil									
Daki									
Binjai									
Kedah Lada									
Pangau									
Kuala Beringin									
Kampung Panti Ganti									
Stabar									
Tanjung Patah									
Tanjung Selamat									
Kuala Perantas									
Tanjung Pura Batu									
Tanjung Pura									
Gehang									
Pangkalan Brandan									
Besitang									
Medan									
Bandar Kalipah									
Araskabu									
Kualanamu									
Tebing Tinggi									
Sip Pahau									
Naga Kevangan									
Sip O. Kutaran									
Beau Linggih									
Sip Dikon									
Dolak Merangin									
Sirakak									
Sip STTC									
Sip Mandas									
Siantar									
Sip Pening									
Bandar Tinggi									
Tanjung Gading									
Lalang									
Kuala Tanjung									
Kisaran									
Serangan									
Kalua Suya									
Air Jantan									
Tanjung Balai									
Sip Muka Nibung									
Kruenggeukueh									
Bungkah									
Kruengmane									
Geumpang									
Kutablang									

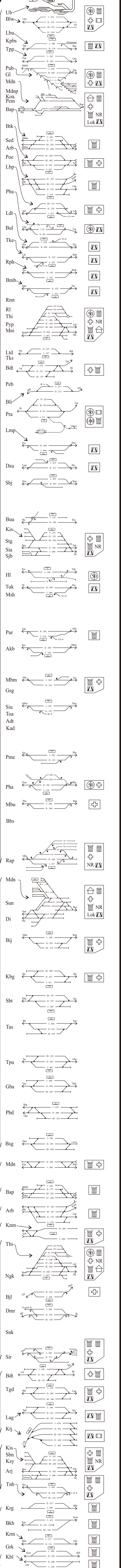
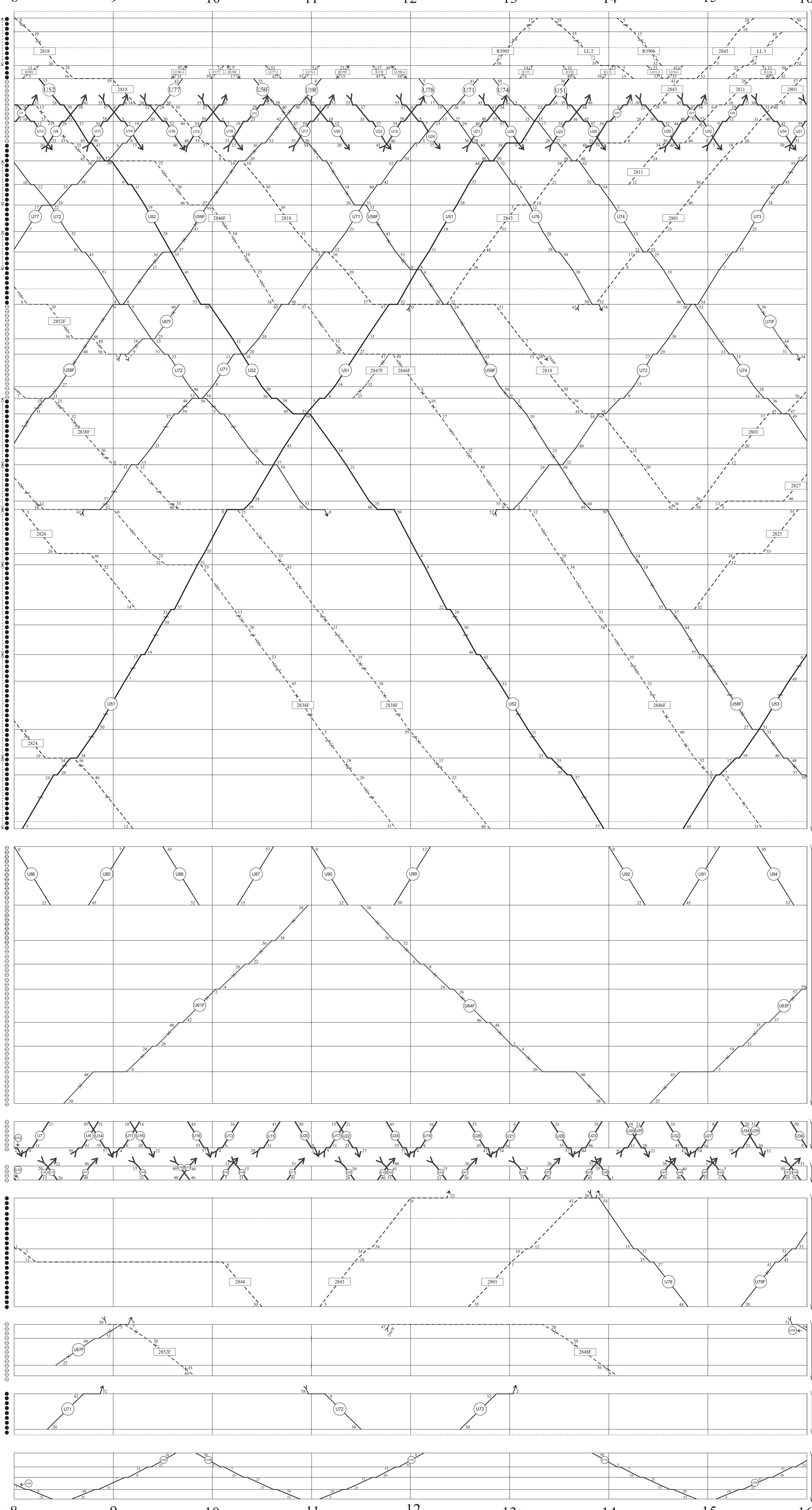



UJUNG BARU - MEDAN - ARASKABU - TEBING TINGGI - BANDAR TINGGI - KISARAN - RANTAU PRAPAT
MEDAN - BESITANG
MEDAN - BANDAR KALIPAH
ARASKABU - KUALANAMU
TEBING TINGGI - SIANTAR
BANDAR TINGGI - KUALA TANJUNG
KISARAN - TANJUNG BALAI - SSP TELUK NIBUNG
KRUENGGUEKUEH - KRUENGMANE - KUTABLANG

1C
16.00-24.00

Yang berhak mengumumkan perjalanan kereta api
Ksb Mdn untuk lintas : Mdn-Biw, Mdn-Knm, Mdn-Tbi, Mdn-Bsg
Ks Tbi untuk lintas : Tbi-Sir, Tbi-Kis, Tbi-Kj
Ksb Kis untuk lintas : Kis-Tnb, Kis-Rap

JALUR GANDA
MDN - BAP
BAP - ARB
ARB - KNM

Berlaku mulai tanggal 1 Juni 2023

(Waktu Indonesia Barat)

No. Urut	Nama Stasiun	Kategori	Kode	Jarak (km)		Kategori	Kode
				MDN - BAP	BAP - ARB		
1	Ujung Baru	Stasiun	UB	0,00	0,00	Stasiun	UB
2	Belawan	Stasiun	BLW	1,90	1,90	Stasiun	BLW
3	Lubau	Stasiun	LU	2,30	2,30	Stasiun	LU
4	Karang Haur	Stasiun	KH	3,70	3,70	Stasiun	KH
5	Titi Papan	Stasiun	TP	8,30	8,30	Stasiun	TP
6	Sip Cijay Bando Jaya	Stasiun	SCBJ	15,00	15,00	Stasiun	SCBJ
7	Medan	Stasiun	MDN	22,31	22,31	Stasiun	MDN
8	Medan Pasar	Stasiun	MP	23,23	23,23	Stasiun	MP
9	Bandar Kalipah	Stasiun	BK	16,13	16,13	Stasiun	BK
10	Batang Kuis	Stasiun	BKUIS	9,13	9,13	Stasiun	BKUIS
11	Araskabu	Stasiun	AR	5,63	5,63	Stasiun	AR
12	Lubuk Pakam	Stasiun	LP	7,21	7,21	Stasiun	LP
13	Perbaungan	Stasiun	PR	6,612	6,612	Stasiun	PR
14	Lidah Tanah	Stasiun	LT	8,424	8,424	Stasiun	LT
15	Teluk Mengkudu	Stasiun	TM	16,85	16,85	Stasiun	TM
16	Rampah	Stasiun	RA	16,80	16,80	Stasiun	RA
17	Bamban	Stasiun	BA	11,47	11,47	Stasiun	BA
18	Tebing Tinggi	Stasiun	TT	13,22	13,22	Stasiun	TT
19	Laui Tador	Stasiun	LT	13,90	13,90	Stasiun	LT
20	Bandar Tinggi	Stasiun	BT	13,90	13,90	Stasiun	BT
21	Bahilau	Stasiun	BAH	32,70	32,70	Stasiun	BAH
22	Perlanjau	Stasiun	PL	33,02	33,02	Stasiun	PL
23	Lima Puluh	Stasiun	LP	34,70	34,70	Stasiun	LP
24	Dusun	Stasiun	DS	19,80	19,80	Stasiun	DS
25	Sibjanjajar	Stasiun	SB	0,30	0,30	Stasiun	SB
26	Bumut	Stasiun	BU	18,37	18,37	Stasiun	BU
27	Kisaran	Stasiun	KIS	19,87	19,87	Stasiun	KIS
28	Hengelo	Stasiun	HE	18,50	18,50	Stasiun	HE
29	Teluk Dalam	Stasiun	TD	27,38	27,38	Stasiun	TD
30	Pulau	Stasiun	PU	28,00	28,00	Stasiun	PU
31	Aekloba	Stasiun	AK	24,00	24,00	Stasiun	AK
32	Membang MUDA	Stasiun	MM	27,50	27,50	Stasiun	MM
33	Sitangir	Stasiun	SI	18,50	18,50	Stasiun	SI
34	Panjenke	Stasiun	PA	26,97	26,97	Stasiun	PA
35	Pulang Halahan	Stasiun	PH	26,90	26,90	Stasiun	PH
36	Marbau	Stasiun	MA	25,81	25,81	Stasiun	MA
37	Besitang	Stasiun	BS	22,30	22,30	Stasiun	BS
38	Medan	Stasiun	MDN	22,85	22,85	Stasiun	MDN
39	Binjai	Stasiun	BJ	26,00	26,00	Stasiun	BJ
40	Kuala Bingei	Stasiun	KB	22,00	22,00	Stasiun	KB
41	Stabar	Stasiun	ST	12,00	12,00	Stasiun	ST
42	Tanjung Selamat	Stasiun	TS	9,00	9,00	Stasiun	TS
43	Gebang	Stasiun	GB	7,00	7,00	Stasiun	GB
44	Pangkalan Brandan	Stasiun	PB	6,00	6,00	Stasiun	PB
45	Besitang	Stasiun	BS	6,00	6,00	Stasiun	BS
46	Medan	Stasiun	MDN	16,13	16,13	Stasiun	MDN
47	Bandar Kalipah	Stasiun	BK	5,63	5,63	Stasiun	BK
48	Araskabu	Stasiun	AR	5,21	5,21	Stasiun	AR
49	Kualanamu	Stasiun	KA	28,6	28,6	Stasiun	KA
50	Tebing Tinggi	Stasiun	TT	27,17	27,17	Stasiun	TT
51	Bandar Tinggi	Stasiun	BT	11,11	11,11	Stasiun	BT
52	Tanjung Gading	Stasiun	TG	3,56	3,56	Stasiun	TG
53	Lalang	Stasiun	LA	3,57	3,57	Stasiun	LA
54	Kuala Tanjung	Stasiun	KT	12,05	12,05	Stasiun	KT
55	Kisaran	Stasiun	KIS	8,07	8,07	Stasiun	KIS
56	Tanjung Balai	Stasiun	TB	4,50	4,50	Stasiun	TB
57	Kruenggeukueh	Stasiun	KG	6,40	6,40	Stasiun	KG
58	Bungkah	Stasiun	BK	4,80	4,80	Stasiun	BK
59	Kruengmane	Stasiun	KM	5,00	5,00	Stasiun	KM
60	Kutablang	Stasiun	KU	4,50	4,50	Stasiun	KU

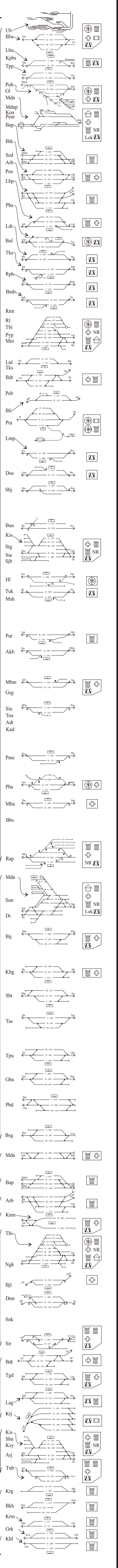
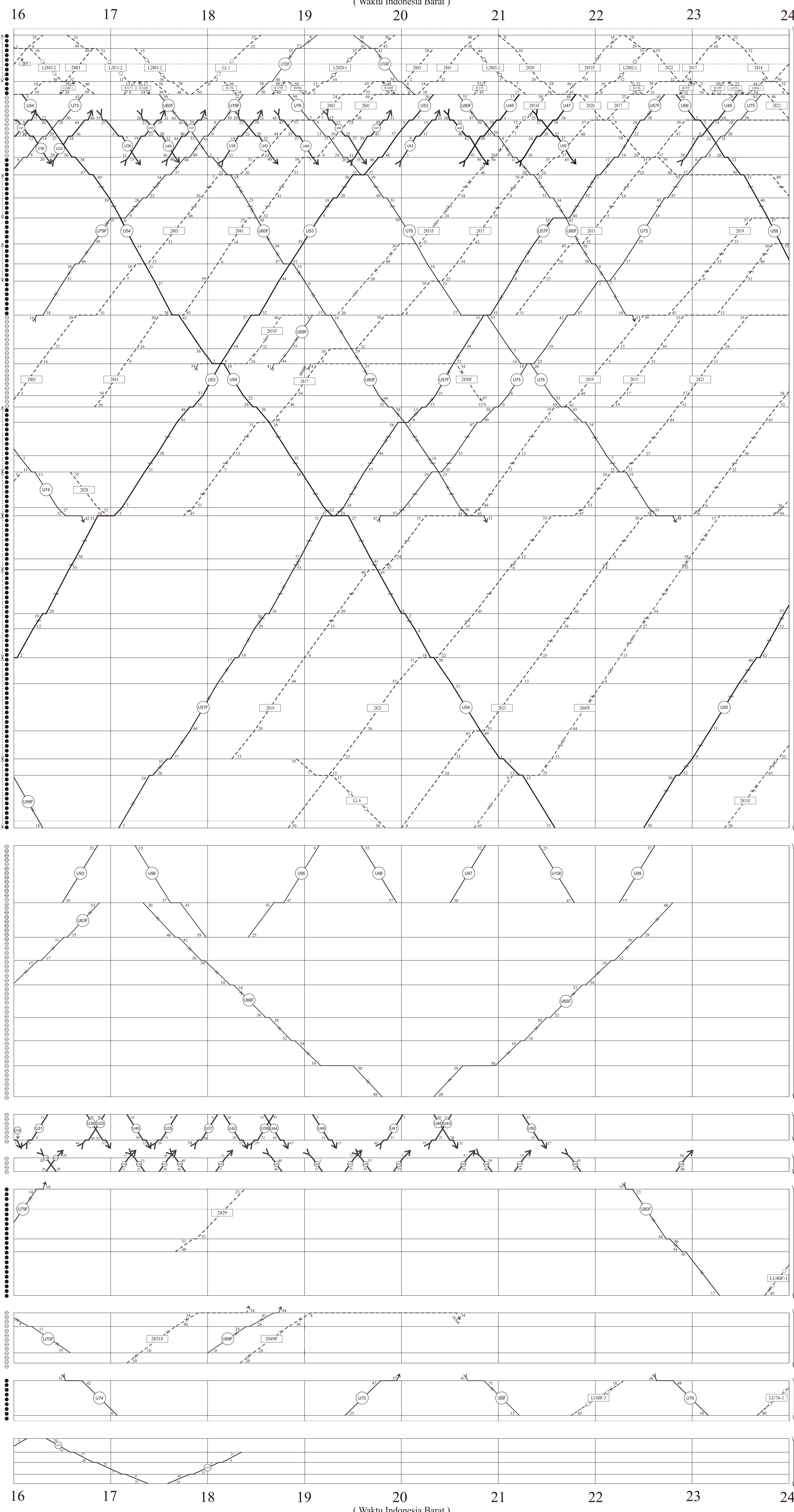

LAMPIRAN II KEPUTUSAN DIREKTUR JENDERAL
PERKERETAAPIAN

NOMOR : KP-DJKA 68 TAHUN 2023

TANGGAL : 14 APRIL 2023



**BUKU PENOMORAN KERETA API,
KAPASITAS LINTAS, DAN JARAK ANTAR STASIUN
JARINGAN JALUR KERETA API NASIONAL DI
SUMATERA BAGIAN UTARA**

**KEMENTERIAN PERHUBUNGAN
DIREKTORAT JENDERAL PERKERETAAPIAN
JAKARTA 2023**

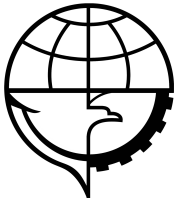

LAMPIRAN II
NOMOR : KP - DJKA 68 TAHUN 2023
TANGGAL : 14 APRIL 2023



Penomoran KA, Kapasitas Lintas & Jarak Antar Stasiun

Jaringan Jalur Kereta Api Nasional Di Sumatera Bagian Utara



Berlaku Pada GAPEKA 2023

KANTOR PUSAT

BANDUNG 2023

PT KERETA API INDONESIA (PERSERO)

**REKAPITULASI JENIS PELAYANAN, KELAS KA & KM KA SUMATERA UTARA
GAPEKA 2023**

NO	JENIS PELAYANAN	KELAS KA	JUMLAH KA			JUMLAH KM KA
			REG	FAK	JUMLAH KA	
1	KOMERSIAL	Bandara	50	0	50	1.372
		Eksekutif Campuran	6	2	8	2.141
		Bisnis	0	2	2	349
		<i>Jumlah Komersial</i>	56	4	60	3.861
2	EKONOMI	Ekonomi 80	0	14	14	613
		Ekonomi	28	2	30	2.037
		KRD Ekonomi	8	0	8	165
		<i>Jumlah Ekonomi</i>	36	16	52	2.814
3	BARANG	BBM	4	0	4	632
		CPO	20	4	24	3.551
		Petikemas	20	4	24	3.551
		<i>Jumlah Barang</i>	44	8	52	7.734
4	DINAS	Dinas Rangkaian Divre I Sumut	24	4	28	172
		Dinas Lokomotif Divre I Sumut	27	6	33	475
		<i>Jumlah Dinas</i>	51	10	61	647
		JUMLAH DIVRE I SUMUT	189	36	225	15.056

PENOMORAN KA

Jaringan Jalur Kereta Api Di Sumatera Bagian Utara

Berlaku Pada GAPEKA 2023

PENOMORAN PERJALANAN KERETA API GAPEKA 2023

KLASIFIKASI KA : KA ANTARKOTA
KELAS KA : KA BANDARA
WILAYAH : DIVRE I SUMUT

REGULER: 50
JUMLAH : 50
KM KA : 1371,700

FAKULTATIF: 0

NO		JENIS PERJALANAN	NAMA KERETA API	LINTAS PELAYANAN	BADAN USAHA PENYELENGGARA SARANA	JARAK	JAM		WP
URUT	KA						BRK	DAT	JAM
1	U1	REGULER	BANDARA KUALANAMU	KNM - MDN	PT. RAILINK	27,434	05.20	05.56	00.36
2	U2	REGULER	BANDARA KUALANAMU	MDN - KNM	PT. RAILINK	27,434	04.00	04.38	00.38
3	U3	REGULER	BANDARA KUALANAMU	KNM - MDN	PT. RAILINK	27,434	06.00	06.36	00.36
4	U4	REGULER	BANDARA KUALANAMU	MDN - KNM	PT. RAILINK	27,434	05.00	05.38	00.38
5	U5	REGULER	BANDARA KUALANAMU	KNM - MDN	PT. RAILINK	27,434	06.50	07.26	00.36
6	U6	REGULER	BANDARA KUALANAMU	MDN - KNM	PT. RAILINK	27,434	06.00	06.38	00.38
7	U7	REGULER	BANDARA KUALANAMU	KNM - MDN	PT. RAILINK	27,434	07.45	08.21	00.36
8	U8	REGULER	BANDARA KUALANAMU	MDN - KNM	PT. RAILINK	27,434	06.35	07.11	00.36
9	U9	REGULER	BANDARA KUALANAMU	KNM - MDN	PT. RAILINK	27,434	08.15	08.51	00.36
10	U10	REGULER	BANDARA KUALANAMU	MDN - KNM	PT. RAILINK	27,434	07.25	08.01	00.36
11	U11	REGULER	BANDARA KUALANAMU	KNM - MDN	PT. RAILINK	27,434	08.40	09.16	00.36
12	U12	REGULER	BANDARA KUALANAMU	MDN - KNM	PT. RAILINK	27,434	07.50	08.26	00.36
13	U13	REGULER	BANDARA KUALANAMU	KNM - MDN	PT. RAILINK	27,434	09.40	10.16	00.36
14	U14	REGULER	BANDARA KUALANAMU	MDN - KNM	PT. RAILINK	27,434	08.45	09.21	00.36
15	U15	REGULER	BANDARA KUALANAMU	KNM - MDN	PT. RAILINK	27,434	10.05	10.41	00.36
16	U16	REGULER	BANDARA KUALANAMU	MDN - KNM	PT. RAILINK	27,434	09.10	09.46	00.36
17	U17	REGULER	BANDARA KUALANAMU	KNM - MDN	PT. RAILINK	27,434	10.45	11.21	00.36
18	U18	REGULER	BANDARA KUALANAMU	MDN - KNM	PT. RAILINK	27,434	09.45	10.21	00.36
19	U19	REGULER	BANDARA KUALANAMU	KNM - MDN	PT. RAILINK	27,434	11.40	12.16	00.36
20	U20	REGULER	BANDARA KUALANAMU	MDN - KNM	PT. RAILINK	27,434	10.50	11.26	00.36
21	U21	REGULER	BANDARA KUALANAMU	KNM - MDN	PT. RAILINK	27,434	12.30	13.06	00.36
22	U22	REGULER	BANDARA KUALANAMU	MDN - KNM	PT. RAILINK	27,434	11.15	11.51	00.36
23	U23	REGULER	BANDARA KUALANAMU	KNM - MDN	PT. RAILINK	27,434	13.20	13.56	00.36
24	U24	REGULER	BANDARA KUALANAMU	MDN - KNM	PT. RAILINK	27,434	11.45	12.21	00.36
25	U25	REGULER	BANDARA KUALANAMU	KNM - MDN	PT. RAILINK	27,434	13.45	14.21	00.36
26	U26	REGULER	BANDARA KUALANAMU	MDN - KNM	PT. RAILINK	27,434	12.35	13.11	00.36
27	U27	REGULER	BANDARA KUALANAMU	KNM - MDN	PT. RAILINK	27,434	14.30	15.06	00.36
28	U28	REGULER	BANDARA KUALANAMU	MDN - KNM	PT. RAILINK	27,434	13.25	14.01	00.36
29	U29	REGULER	BANDARA KUALANAMU	KNM - MDN	PT. RAILINK	27,434	14.55	15.31	00.36
30	U30	REGULER	BANDARA KUALANAMU	MDN - KNM	PT. RAILINK	27,434	14.10	14.46	00.36
31	U31	REGULER	BANDARA KUALANAMU	KNM - MDN	PT. RAILINK	27,434	15.45	16.21	00.36
32	U32	REGULER	BANDARA KUALANAMU	MDN - KNM	PT. RAILINK	27,434	14.35	15.11	00.36
33	U33	REGULER	BANDARA KUALANAMU	KNM - MDN	PT. RAILINK	27,434	16.20	16.56	00.36
34	U34	REGULER	BANDARA KUALANAMU	MDN - KNM	PT. RAILINK	27,434	15.20	15.56	00.36
35	U35	REGULER	BANDARA KUALANAMU	KNM - MDN	PT. RAILINK	27,434	17.05	17.41	00.36
36	U36	REGULER	BANDARA KUALANAMU	MDN - KNM	PT. RAILINK	27,434	15.50	16.26	00.36
37	U37	REGULER	BANDARA KUALANAMU	KNM - MDN	PT. RAILINK	27,434	17.30	18.06	00.36
38	U38	REGULER	BANDARA KUALANAMU	MDN - KNM	PT. RAILINK	27,434	16.45	17.21	00.36

NO		JENIS PERJALANAN	NAMA KERETA API	LINTAS PELAYANAN	BADAN USAHA PENYELENGGARA SARANA	JARAK	JAM		WP
URUT	KA						BRK	DAT	JAM
39	U39	REGULER	BANDARA KUALANAMU	KNM - MDN	PT. RAILINK	27,434	18.05	18.41	00.36
40	U40	REGULER	BANDARA KUALANAMU	MDN - KNM	PT. RAILINK	27,434	17.10	17.46	00.36
41	U41	REGULER	BANDARA KUALANAMU	KNM - MDN	PT. RAILINK	27,434	19.25	20.01	00.36
42	U42	REGULER	BANDARA KUALANAMU	MDN - KNM	PT. RAILINK	27,434	18.10	18.46	00.36
43	U43	REGULER	BANDARA KUALANAMU	KNM - MDN	PT. RAILINK	27,434	19.55	20.31	00.36
44	U44	REGULER	BANDARA KUALANAMU	MDN - KNM	PT. RAILINK	27,434	18.35	19.11	00.36
45	U45	REGULER	BANDARA KUALANAMU	KNM - MDN	PT. RAILINK	27,434	20.35	21.13	00.38
46	U46	REGULER	BANDARA KUALANAMU	MDN - KNM	PT. RAILINK	27,434	19.05	19.41	00.36
47	U47	REGULER	BANDARA KUALANAMU	KNM - MDN	PT. RAILINK	27,434	21.10	21.48	00.38
48	U48	REGULER	BANDARA KUALANAMU	MDN - KNM	PT. RAILINK	27,434	20.20	20.56	00.36
49	U49	REGULER	BANDARA KUALANAMU	KNM - MDN	PT. RAILINK	27,434	22.50	23.28	00.38
50	U50	REGULER	BANDARA KUALANAMU	MDN - KNM	PT. RAILINK	27,434	21.15	21.51	00.36
50	JUMLAH KA DAN KM-KA					1371,700			

KLASIFIKASI KA : KA ANTARKOTA
 KELAS KA : KA EKSEKUTIF CAMPURAN
 WILAYAH : DIVRE I SUMUT

REGULER: 6
 JUMLAH : 8
 FAKULTATIF: 2
 KM KA : 2140,888

NO		JENIS PERJALANAN	NAMA KERETA API	LINTAS PELAYANAN	BADAN USAHA PENYELENGGARA SARANA	JARAK	JAM		WP
URUT	KA						BRK	DAT	JAM
1	U51	REGULER	SRIBILAH UTAMA	RAP - MDN	PT. KAI	267,611	08.05	13.36	05.31
2	U52	REGULER	SRIBILAH UTAMA	MDN - RAP	PT. KAI	267,611	08.15	13.57	05.42
3	U53	REGULER	SRIBILAH UTAMA	RAP - MDN	PT. KAI	267,611	14.45	20.20	05.35
4	U54	REGULER	SRIBILAH UTAMA	MDN - RAP	PT. KAI	267,611	16.05	21.35	05.30
5	U55	REGULER	SRIBILAH UTAMA	RAP - MDN	PT. KAI	267,611	22.30	03.44	05.14
6	U56	REGULER	SRIBILAH UTAMA	MDN - RAP	PT. KAI	267,611	22.50	04.10	05.20
7	U57F	FAKULTATIF	SRIBILAH UTAMA	RAP - MDN	PT. KAI	267,611	17.05	22.43	05.38
8	U58F	FAKULTATIF	SRIBILAH UTAMA	MDN - RAP	PT. KAI	267,611	10.25	16.18	05.53
8	JUMLAH KA DAN KM-KA					2.140,888			

KLASIFIKASI KA : KA ANTARKOTA
 KELAS KA : KA BISNIS
 WILAYAH : DIVRE I SUMUT

REGULER: 0
 JUMLAH : 2
 FAKULTATIF: 2
 KM KA : 348,844

NO		JENIS PERJALANAN	NAMA KERETA API	LINTAS PELAYANAN	BADAN USAHA PENYELENGGARA SARANA	JARAK	JAM		WP
URUT	KA						BRK	DAT	JAM
1	U59F	FAKULTATIF	TANJUNG BALAI EKSPRES	TNB - MDN	PT. KAI	174,422	07.00	11.06	04.06
2	U60F	FAKULTATIF	TANJUNG BALAI EKSPRES	MDN - TNB	PT. KAI	174,422	17.30	21.13	03.43
2	JUMLAH KA DAN KM-KA					348,844			

NO		JENIS PERJALANAN	NAMA KERETA API	LINTAS PELAYANAN	BADAN USAHA PENYELENGGARA SARANA	JARAK	JAM		WP
URUT	KA						BRK	DAT	JAM

KLASIFIKASI KA : KA PERKOTAAN
KELAS KA : KA EKONOMI 80
WILAYAH : DIVRE I SUMUT

REGULER: 0
JUMLAH : 14
KM KA : 612,820
FAKULTATIF 14

NO		JENIS PERJALANAN	NAMA KERETA API	LINTAS PELAYANAN	BADAN USAHA PENYELENGGARA SARANA	JARAK	JAM		WP
URUT	KA						BRK	DAT	JAM
1	U61F	FAKULTATIF	AMIR HAMZAH	BSG - BIJ	PT. KAI	78,400	08.30	10.58	02.28
2	U62F	FAKULTATIF	AMIR HAMZAH	BIJ - BSG	PT. KAI	78,400	05.30	07.58	02.28
3	U63F	FAKULTATIF	AMIR HAMZAH	BSG - BIJ	PT. KAI	78,400	14.25	16.53	02.28
4	U64F	FAKULTATIF	AMIR HAMZAH	BIJ - BSG	PT. KAI	78,400	11.30	13.58	02.28
5	U65F	FAKULTATIF	AMIR HAMZAH	BSG - BIJ	PT. KAI	78,400	20.20	22.48	02.28
6	U66F	FAKULTATIF	AMIR HAMZAH	BIJ - BSG	PT. KAI	78,400	17.20	19.48	02.28
7	U67F	FAKULTATIF	DATUK BELAMBANGAN	LAG - TBI	PT. KAI	35,605	08.25	09.40	01.15
8	U68F	FAKULTATIF	DATUK BELAMBANGAN	TBI - LAG	PT. KAI	35,605	06.20	07.25	01.05
9	U69F	FAKULTATIF	DATUK BELAMBANGAN	LAG - TBI	PT. KAI	35,605	18.00	19.05	01.05
10	U70F	FAKULTATIF	DATUK BELAMBANGAN	TBI - LAG	PT. KAI	35,605	15.30	16.35	01.05
11	U101F	FAKULTATIF	BELAWAN INDAH	MDN - BLW	PT. KAI	21,607	04.50	05.28	00.38
12	U102F	FAKULTATIF	BELAWAN INDAH	BLW - MDN	PT. KAI	21,607	06.03	06.45	00.42
13	U103F	FAKULTATIF	BELAWAN INDAH	MDN - BLW	PT. KAI	21,607	18.30	19.08	00.38
14	U104F	FAKULTATIF	BELAWAN INDAH	BLW - MDN	PT. KAI	21,607	19.30	20.08	00.38
14	JUMLAH KA DAN KM-KA					612,820			

KLASIFIKASI KA : KA ANTARKOTA
KELAS KA : KA EKONOMI
WILAYAH : DIVRE I SUMUT

REGULER: 8
JUMLAH : 10
KM KA : 1.562,568
FAKULTATIF: 2

NO		JENIS PERJALANAN	NAMA KERETA API	LINTAS PELAYANAN	BADAN USAHA PENYELENGGARA SARANA	JARAK	JAM		WP
URUT	KA						BRK	DAT	JAM
1	U71	REGULER	PUTRI DELI	TNB - MDN	PT. KAI	174,422	08.20	12.41	04.21
2	U72	REGULER	PUTRI DELI	MDN - TNB	PT. KAI	174,422	07.10	11.30	04.20
3	U73	REGULER	PUTRI DELI	TNB - MDN	PT. KAI	174,422	12.30	16.43	04.13
4	U74	REGULER	PUTRI DELI	MDN - TNB	PT. KAI	174,422	12.50	17.04	04.14
5	U75	REGULER	PUTRI DELI	TNB - MDN	PT. KAI	174,422	19.25	23.43	04.18
6	U76	REGULER	PUTRI DELI	MDN - TNB	PT. KAI	174,422	18.50	23.10	04.20
7	U77	REGULER	SIANTAR EKSPRES	SIR - MDN	PT. KAI	129,009	06.40	09.42	03.02
8	U78	REGULER	SIANTAR EKSPRES	MDN - SIR	PT. KAI	129,009	12.05	14.48	02.43
9	U79F	FAKULTATIF	SIANTAR EKSPRES	SIR - MDN	PT. KAI	129,009	15.20	18.22	03.02
10	U80F	FAKULTATIF	SIANTAR EKSPRES	MDN - SIR	PT. KAI	129,009	20.35	23.17	02.42
10	JUMLAH KA DAN KM-KA					1562,568			

NO		JENIS PERJALANAN	NAMA KERETA API	LINTAS PELAYANAN	BADAN USAHA PENYELENGGARA SARANA	JARAK	JAM		WP
URUT	KA						BRK	DAT	JAM

KLASIFIKASI KA : KA PERKOTAAN
KELAS KA : KA EKONOMI
WILAYAH : DIVRE I SUMUT

REGULER: 20
JUMLAH : 20
KM KA : 473,980

FAKULTATIF 0

NO		JENIS PERJALANAN	NAMA KERETA API	LINTAS PELAYANAN	BADAN USAHA PENYELENGGARA SARANA	JARAK	JAM		WP	
URUT	KA						BRK	DAT	JAM	
1	U81	REGULER	SRI LELAWANGSA	BIJ - MDN	PT. KAI	20,889	04.50	05.12	00.22	
2	U82	REGULER	SRI LELAWANGSA	MDN - BIJ	PT. KAI	20,889	04.05	04.27	00.22	
3	U83	REGULER	SRI LELAWANGSA	KBG - MDN	PT. KAI	34,939	06.45	07.32	00.47	
4	U84	REGULER	SRI LELAWANGSA	MDN - KBG	PT. KAI	34,939	05.35	06.18	00.43	
5	U85	REGULER	SRI LELAWANGSA	BIJ - MDN	PT. KAI	20,889	08.45	09.07	00.22	
6	U86	REGULER	SRI LELAWANGSA	MDN - BIJ	PT. KAI	20,889	08.00	08.22	00.22	
7	U87	REGULER	SRI LELAWANGSA	BIJ - MDN	PT. KAI	20,889	10.15	10.37	00.22	
8	U88	REGULER	SRI LELAWANGSA	MDN - BIJ	PT. KAI	20,889	09.30	09.52	00.22	
9	U89	REGULER	SRI LELAWANGSA	BIJ - MDN	PT. KAI	20,889	11.50	12.12	00.22	
10	U90	REGULER	SRI LELAWANGSA	MDN - BIJ	PT. KAI	20,889	11.00	11.22	00.22	
11	U91	REGULER	SRI LELAWANGSA	BIJ - MDN	PT. KAI	20,889	14.45	15.07	00.22	
12	U92	REGULER	SRI LELAWANGSA	MDN - BIJ	PT. KAI	20,889	14.00	14.22	00.22	
13	U93	REGULER	SRI LELAWANGSA	BIJ - MDN	PT. KAI	20,889	16.30	16.52	00.22	
14	U94	REGULER	SRI LELAWANGSA	MDN - BIJ	PT. KAI	20,889	15.30	15.52	00.22	
15	U95	REGULER	SRI LELAWANGSA	KBG - MDN	PT. KAI	34,939	18.25	19.09	00.44	
16	U96	REGULER	SRI LELAWANGSA	MDN - KBG	PT. KAI	34,939	17.15	17.59	00.44	
17	U97	REGULER	SRI LELAWANGSA	BIJ - MDN	PT. KAI	20,889	20.30	20.52	00.22	
18	U98	REGULER	SRI LELAWANGSA	MDN - BIJ	PT. KAI	20,889	19.35	19.57	00.22	
19	U99	REGULER	SRI LELAWANGSA	BIJ - MDN	PT. KAI	20,889	22.15	22.37	00.22	
20	U100	REGULER	SRI LELAWANGSA	MDN - BIJ	PT. KAI	20,889	21.25	21.47	00.22	
20	JUMLAH KA DAN KM-KA						473,980			

KLASIFIKASI KA : KA PERKOTAAN
KELAS KA : KR D EKONOMI
WILAYAH : DIVRE I SUMUT

REGULER: 8
JUMLAH : 8
KM KA : 164,750

FAKULTATIF 0

NO		JENIS PERJALANAN	NAMA KERETA API	LINTAS PELAYANAN	BADAN USAHA PENYELENGGARA SARANA	JARAK	JAM		WP
URUT	KA						BRK	DAT	JAM
1	U105	REGULER	CUT MEUTIA	KBL - KRG	PT. KAI	21,400	08.35	09.38	01.03
2	U106	REGULER	CUT MEUTIA	KRG - KBL	PT. KAI	21,400	07.20	08.23	01.03
3	U107	REGULER	CUT MEUTIA	KBL - KRG	PT. KAI	21,400	11.05	12.08	01.03
4	U108	REGULER	CUT MEUTIA	KRG - KBL	PT. KAI	21,400	09.50	10.53	01.03
5	U109	REGULER	CUT MEUTIA	KBL - KRG	PT. KAI	21,400	15.05	16.08	01.03
6	U110	REGULER	CUT MEUTIA	KRG - KBL	PT. KAI	21,400	13.50	14.53	01.03

NO		JENIS PERJALANAN	NAMA KERETA API	LINTAS PELAYANAN	BADAN USAHA PENYELENGGARA SARANA	JARAK	JAM		WP
URUT	KA						BRK	DAT	JAM
7	U111	REGULER	CUT MEUTIA	KBL - BKH	PT. KAI	14,950	17.35	18.21	00.46
8	U112	REGULER	CUT MEUTIA	KRG - KBL	PT. KAI	21,400	16.20	17.23	01.03
8	JUMLAH KA DAN KM-KA					164,750			

KLASIFIKASI KA : KA PERKOTAAN
 KELAS KA : KA BARANG BBM
 WILAYAH : DIVRE I SUMUT

REGULER: 4
 JUMLAH : 4
 FAKULTATIF: 0
 KM KA : 632,364

NO		JENIS PERJALANAN	NAMA KERETA API	LINTAS PELAYANAN	BADAN USAHA PENYELENGGARA SARANA	JARAK	JAM		WP
URUT	KA						BRK	DAT	JAM
1	2801	REGULER	SITARBU EKSPRES	SIR - LBU	PT. KAI	145,726	12.35	16.49	04.14
2	2802	REGULER	SITARBU EKSPRES	LBU - SIR	PT. KAI	145,726	00.15	05.25	05.10
3	2803	REGULER	KISARBU EKSPRES	KIS - LBU	PT. KAI	170,456	14.50	20.20	05.30
4	2804	REGULER	KISARBU EKSPRES	LBU - KIS	PT. KAI	170,456	01.18	06.46	05.28
4	JUMLAH KA DAN KM-KA					632,364			

KLASIFIKASI KA : KA PERKOTAAN
 KELAS KA : KA BARANG CPO
 WILAYAH : DIVRE I SUMUT

REGULER: 20
 JUMLAH : 24
 FAKULTATIF: 4
 KM KA : 3.550,680

NO		JENIS PERJALANAN	NAMA KERETA API	LINTAS PELAYANAN	BADAN USAHA PENYELENGGARA SARANA	JARAK	JAM		WP
URUT	KA						BRK	DAT	JAM
1	2813	REGULER	TEBEL CPO	TBI - BLW	PT. KAI	102,149	21.11	01.25	04.14
2	2814	REGULER	TEBEL CPO	BLW - TBI	PT. KAI	102,149	23.22	02.42	03.20
3	2815	REGULER	PRANABEL CPO	PRA - BLW	PT. KAI	135,660	22.10	03.09	04.59
4	2816	REGULER	PRANABEL CPO	BLW - PRA	PT. KAI	135,660	02.00	06.36	04.36
5	2817	REGULER	KISABEL CPO	KIS - BLW	PT. KAI	175,346	17.45	23.20	05.35
6	2818	REGULER	KISABEL CPO	BLW - KIS	PT. KAI	175,346	08.00	14.42	06.42
7	2819	REGULER	PAHABEL CPO	PHA - BLW	PT. KAI	264,018	18.15	02.30	08.15
8	2820	REGULER	PAHABEL CPO	BLW - PHA	PT. KAI	264,018	21.00	05.30	08.30
9	2821	REGULER	RANPABEL CPO	RAP - BLW	PT. KAI	289,218	18.50	03.49	08.59
10	2822	REGULER	RANPABEL CPO	BLW - RAP	PT. KAI	289,218	22.18	07.10	08.52
11	2823	REGULER	RANPABEL CPO	RAP - BLW	PT. KAI	289,218	20.00	05.53	09.53
12	2824	REGULER	RANPABEL CPO	BLW - RAP	PT. KAI	289,218	00.30	09.12	08.42
13	2825	REGULER	PURJAKIS CPO	PUR - KIS	PT. KAI	35,670	14.52	15.55	01.03
14	2826	REGULER	PURJAKIS CPO	KIS - PUR	PT. KAI	35,670	08.05	09.14	01.09
15	2827	REGULER	SIBERKIS CPO	KIS - SBJ	PT. KAI	15,982	15.05	16.05	01.00
16	2828	REGULER	SIBERKIS CPO	SBJ - KIS	PT. KAI	15,982	16.35	16.58	00.23
17	2829	REGULER	DOLBING CPO	DMR - TBI	PT. KAI	28,542	17.40	18.23	00.43
18	2830	REGULER	DOLBING CPO	TBI - DMR	PT. KAI	28,542	06.05	06.48	00.43
19	2831F - 2832F	FAKULTATIF	RANBAKU CPO	RAP - BDT - KTJ	PT. KAI	190,070	23.20	04.43	05.23
20	2833F - 2834F	FAKULTATIF	RANBAKU CPO	KTJ - BDT - RAP	PT. KAI	190,070	05.15	11.51	06.36
21	2835F - 2836F	FAKULTATIF	RANBAKU CPO	RAP - BDT - KTJ	PT. KAI	190,070	00.15	05.43	05.28
22	2837F - 2838F	FAKULTATIF	RANBAKU CPO	KTJ - BDT - RAP	PT. KAI	190,070	06.20	12.48	06.28
23	2811	REGULER	PERBABEL CPO	PBA - BLW	PT. KAI	59,397	14.12	16.18	02.06
24	2812	REGULER	PERBABEL CPO	BLW - PBA	PT. KAI	59,397	05.30	07.52	02.22
24	JUMLAH KA DAN KM-KA					3.550,680			

NO		JENIS PERJALANAN	NAMA KERETA API	LINTAS PELAYANAN	BADAN USAHA PENYELENGGARA SARANA	JARAK	JAM		WP
URUT	KA						BRK	DAT	JAM

KLASIFIKASI KA : KA PERKOTAAN
 KELAS KA : KA BARANG PETIKEMAS
 WILAYAH : DIVRE I SUMUT

REGULER: 4
 JUMLAH : 10
 KM KA : 1.505,308

FAKULTATIF: 6

NO		JENIS PERJALANAN	NAMA KERETA API	LINTAS PELAYANAN	BADAN USAHA PENYELENGGARA SARANA	JARAK	JAM		WP
URUT	KA						BRK	DAT	JAM
1	2841	REGULER	PRABA CARGO	PRA - BLW	PT. KAI	135,660	16.50	20.48	03.58
2	2842	REGULER	PRABA CARGO	BLW - PRA	PT. KAI	135,660	02.40	07.17	04.37
3	2843	REGULER	SITABEL CARGO	SIR - BLW	PT. KAI	150,616	11.05	15.28	04.23
4	2844	REGULER	SITABEL CARGO	BLW - SIR	PT. KAI	150,616	03.20	10.30	07.10
5	2845F	FAKULTATIF	RANBA CARGO	RAP - BLW	PT. KAI	289,218	20.45	06.28	09.43
6	2846F	FAKULTATIF	RANBA CARGO	BLW - RAP	PT. KAI	289,218	06.45	15.33	08.48
7	2847F - 2848F	FAKULTATIF	PRAKUTA CARGO	PRA - BDT - KTJ	PT. KAI	36,512	11.25	14.05	02.40
8	2849F - 2850F	FAKULTATIF	PRAKUTA CARGO	KTJ - BDT - PRA	PT. KAI	36,512	18.20	20.53	02.33
9	2851F	FAKULTATIF	UTABA CARGO	KTJ - BLW	PT. KAI	140,648	17.10	22.16	05.06
10	2852F	FAKULTATIF	UTABA CARGO	BLW - KTJ	PT. KAI	140,648	04.25	09.49	05.24
10	JUMLAH KA DAN KM-KA					1.505,308			

KLASIFIKASI KA : KA DINAS
 KELAS KA : DINAS RANGKAIAN DIVRE I SUMUT
 WILAYAH : SUMATERA

REGULER: 22
 JUMLAH : 28
 KM KA : 171,999

FAKULTATIF: 6

NO		JENIS PERJALANAN	NAMA KERETA API	LINTAS PELAYANAN	BADAN USAHA PENYELENGGARA SARANA	JARAK	JAM		WP
URUT	KA						BRK	DAT	JAM
1	R2802	REGULER	DINAS RANGKAIAN	DMR - SIR		19,925	07.05	07.33	00.28
2	R3903	REGULER	DINAS RANGKAIAN	MDN - PUB		4,655	08.05	08.15	00.10
3	R3904	REGULER	DINAS RANGKAIAN	PUB - MDN		4,655	18.50	19.00	00.10
4	R3905	REGULER	DINAS RANGKAIAN	PUB - BLW		16,952	12.50	13.17	00.27
5	R3906	REGULER	DINAS RANGKAIAN	BLW - PUB		16,952	14.05	14.32	00.27
6	RU106-1	REGULER	DINAS RANGKAIAN	BKH - KRG		6,450	06.45	07.00	00.15
7	RU51	REGULER	DINAS RANGKAIAN	MDN - PUB		4,655	13.56	14.03	00.07
8	RU52	REGULER	DINAS RANGKAIAN	PUB - MDN		4,655	07.42	07.50	00.08
9	RU53	REGULER	DINAS RANGKAIAN	MDN - PUB		4,655	20.45	20.52	00.07
10	RU54	REGULER	DINAS RANGKAIAN	PUB - MDN		4,655	15.33	15.40	00.07
11	RU55	REGULER	DINAS RANGKAIAN	MDN - PUB		4,655	03.58	04.05	00.07
12	RU56	REGULER	DINAS RANGKAIAN	PUB - MDN		4,655	22.22	22.29	00.07
13	RU57F	FAKULTATIF	DINAS RANGKAIAN	MDN - PUB		4,655	22.52	23.00	00.08
14	RU58F	FAKULTATIF	DINAS RANGKAIAN	PUB - MDN		4,655	10.09	10.17	00.08
15	RU59F	FAKULTATIF	DINAS RANGKAIAN	MDN - PUB		4,655	11.15	11.23	00.08
16	RU60F	FAKULTATIF	DINAS RANGKAIAN	PUB - MDN		4,655	17.17	17.24	00.07
17	RU71	REGULER	DINAS RANGKAIAN	MDN - PUB		4,655	13.06	13.14	00.08
18	RU72	REGULER	DINAS RANGKAIAN	PUB - MDN		4,655	04.17	04.24	00.07
19	RU73	REGULER	DINAS RANGKAIAN	MDN - PUB		4,655	17.08	17.15	00.07
20	RU75	REGULER	DINAS RANGKAIAN	MDN - PUB		4,655	00.08	00.15	00.07
21	RU76	REGULER	DINAS RANGKAIAN	PUB - MDN		4,655	18.10	18.18	00.08
22	RU77	REGULER	DINAS RANGKAIAN	MDN - PUB		4,655	09.59	10.07	00.08
23	RU78	REGULER	DINAS RANGKAIAN	PUB - MDN		4,655	11.37	11.45	00.08

NO		JENIS PERJALANAN	NAMA KERETA API	LINTAS PELAYANAN	BADAN USAHA PENYELENGGARA SARANA	JARAK	JAM		WP
URUT	KA						BRK	DAT	JAM
24	RU79F	FAKULTATIF	DINAS RANGKAIAN	MDN - PUB		4,655	18.40	18.48	00.08
25	RU80F	FAKULTATIF	DINAS RANGKAIAN	PUB - MDN		4,655	19.48	19.56	00.08
26	RU82	REGULER	DINAS RANGKAIAN	PUB - MDN		4,655	03.27	03.35	00.08
27	RU92	REGULER	DINAS RANGKAIAN	PUB - MDN		4,655	13.32	13.40	00.08
28	RU99	REGULER	DINAS RANGKAIAN	MDN - PUB		4,655	23.12	23.20	00.08
28	JUMLAH KA DAN KM-KA					171,999			

KLASIFIKASI KA : **KA DINAS**
KELAS KA : **DINAS LOKOMOTIF DIVRE I SUMUT**
WILAYAH : **SUMATERA**

REGULER: 26
JUMLAH : 33
KM KA : 475,031

Fak : 7

NO		JENIS PERJALANAN	NAMA KERETA API	LINTAS PELAYANAN	BADAN USAHA PENYELENGGARA SARANA	JARAK	JAM		WP
URUT	KA						BRK	DAT	JAM
1	LU51-2	REGULER	DINAS LOK	PUB - MDN		4,655	14.23	14.33	00.10
2	LU52-1	REGULER	DINAS LOK	MDN - PUB		4,655	06.55	07.05	00.10
3	LU54-1	REGULER	DINAS LOK	MDN - PUB		4,655	14.35	14.45	00.10
4	LU55-2	REGULER	DINAS LOK	PUB - MDN		4,655	04.28	04.38	00.10
5	LU57F-2	FAKULTATIF	DINAS LOK	PUB - MDN		4,655	23.22	23.32	00.10
6	LU58F-1	FAKULTATIF	DINAS LOK	MDN - PUB		4,655	09.35	09.45	00.10
7	LU59F-2	FAKULTATIF	DINAS LOK	KIS - TNB		20,683	05.30	06.03	00.33
8	LU59F-4	FAKULTATIF	DINAS LOK	PUB - MDN		4,655	11.48	11.58	00.10
9	LU60F-1	FAKULTATIF	DINAS LOK	MDN - PUB		4,655	16.28	16.38	00.10
10	LU60F-3	FAKULTATIF	DINAS LOK	TNB - KIS		20,683	21.45	22.18	00.33
11	LU71-2	REGULER	DINAS LOK	KIS - TNB		20,683	06.10	06.43	00.33
12	LU72-1	REGULER	DINAS LOK	MDN - PUB		4,655	03.37	03.47	00.10

NO		JENIS PERJALANAN	NAMA KERETA API	LINTAS PELAYANAN	BADAN USAHA PENYELENGGARA SARANA	JARAK	JAM		WP
URUT	KA						BRK	DAT	JAM
13	LU75-2	REGULER	DINAS LOK	PUB - MDN		4,655	01.15	01.25	00.10
14	LU76-1	REGULER	DINAS LOK	TNB - KIS		20,683	23.40	00.13	00.33
15	LU77-2	REGULER	DINAS LOK	PUB - MDN		4,655	10.32	10.42	00.10
16	LU78-1	REGULER	DINAS LOK	MDN - PUB		4,655	10.55	11.05	00.10
17	LU80F-1	FAKULTATIF	DINAS LOK	SIR - TBI		48,467	23.45	01.10	01.25
18	LU82-1	REGULER	DINAS LOK	MDN - PUB		4,655	02.51	03.01	00.10
19	LU99-2	REGULER	DINAS LOK	PUB - MDN		4,655	00.17	00.27	00.10
20	L2801-2	REGULER	DINAS LOK	LBU - MDN		16,717	17.15	17.48	00.33
21	L2802-1	REGULER	DINAS LOK	MDN - LBU		16,717	22.00	22.33	00.33
22	L2802-3	REGULER	DINAS LOK	SIR - DMR		19,925	06.00	06.35	00.35
23	L2803-2	REGULER	DINAS LOK	LBU - MDN		16,717	20.44	21.17	00.33
24	L2804-1	REGULER	DINAS LOK	MDN - LBU		16,717	23.34	00.11	00.37
25	L2811-2	REGULER	DINAS LOK	BLW - MDN		21,607	16.33	17.36	01.03
26	L2820-1	REGULER	DINAS LOK	MDN - BLW		21,607	19.02	19.56	00.54
27	L2843-2	REGULER	DINAS LOK	BLW - MDN		21,607	15.50	16.50	01.00
28	LL1	REGULER	DINAS LOK LOK LANGSIR	MDN - BLW		21,607	17.50	18.33	00.43
29	LL2	REGULER	DINAS LOK LOK LANGSIR	BLW - MDN		21,607	13.25	14.15	00.50
30	LL3	REGULER	DINAS LOK LOK LANGSIR	MDN - LBU		16,717	15.12	15.45	00.33
31	LL4	REGULER	DINAS LOK LOK LANGSIR	LBU - MDN		16,717	01.38	02.16	00.38
32	LL5	REGULER	DINAS LOK LOK LANGSIR	RAP - PHA		25,200	05.10	05.50	00.40
33	LL6	REGULER	DINAS LOK LOK LANGSIR	PHA - RAP		25,200	18.55	19.50	00.55
33	JUMLAH KA DAN KM-KA					475,031			

KAPASITAS LINTAS

Jaringan Jalur Kereta Api Di Sumatera Bagian Utara

Berlaku Pada GAPEKA 2023

PROGRAM KA DAN KAPASITAS LINTAS DIVRE I SUMUT GAPEKA 2023

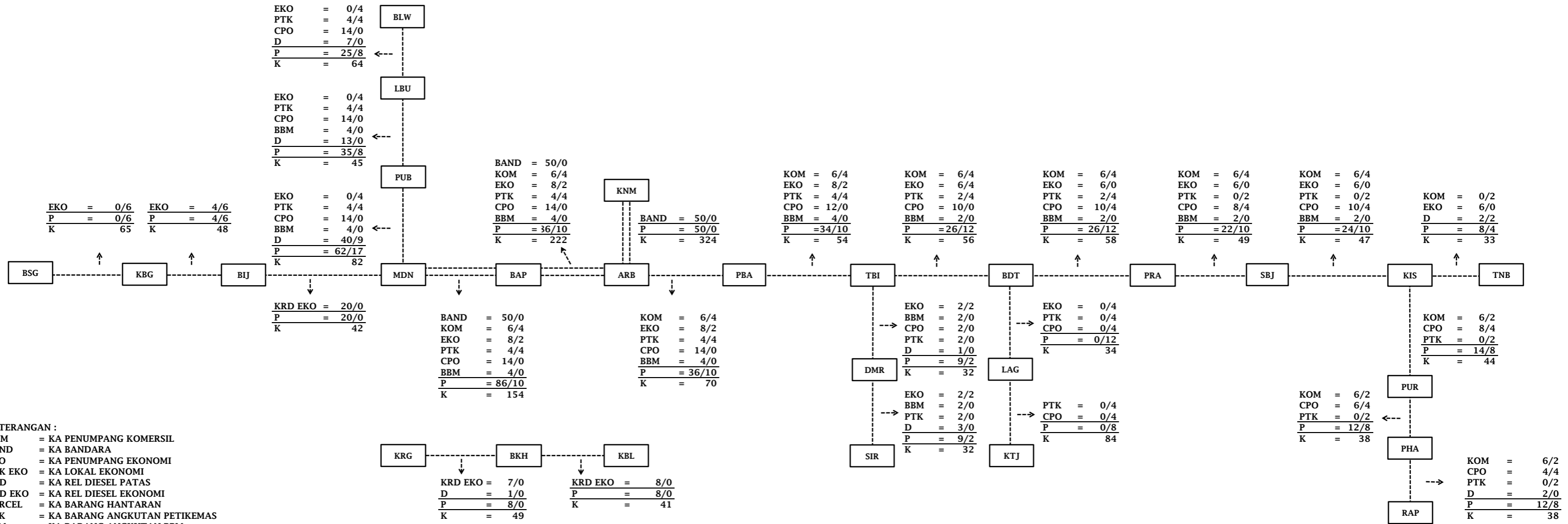

- KETERANGAN :**
- KOM = KA PENUMPANG KOMERSIL
 - BAND = KA BANDARA
 - EKO = KA PENUMPANG EKONOMI
 - LOK EKO = KA LOKAL EKONOMI
 - KRD = KA REL DIESEL PATAS
 - KRD EKO = KA REL DIESEL EKONOMI
 - PARCEL = KA BARANG HANTARAN
 - PTK = KA BARANG ANGKUTAN PETIKEMAS
 - BBM = KA BARANG ANGKUTAN BBM
 - BAR = KA BARANG ANGKUTAN BATUBARA
 - SEMEN = KA BARANG ANGKUTAN SEMEN
 - PUPUK = KA BARANG ANGKUTAN PUPUK
 - KLINKER = KA BARANG ANGKUTAN PASIR
 - CPO = KA BARANG ANGKUTAN CPO
 - D = KA DINAS
 - P = PROGRAM
 - K = KAPASITAS
 - .../... = REGULER/FAKULTATIF

KANTOR PUSAT
BANDUNG 2023



JARAK ANTAR STASIUN

Jaringan Jalur Kereta Api Di Sumatera Bagian Utara

Berlaku Pada GAPEKA 2023

PT KERETA API INDONESIA (PERSERO)

LAMPIRAN III KEPUTUSAN DIREKTUR JENDERAL
PERKERETAAPIAN

NOMOR : KP-DJKA 68 TAHUN 2023

TANGGAL : 14 APRIL 2023



**BUKU PERJALANAN KERETA API
JARINGAN JALUR KERETA API NASIONAL DI
SUMATERA BAGIAN UTARA**

**KEMENTERIAN PERHUBUNGAN
DIREKTORAT JENDERAL PERKERETAAPIAN
JAKARTA 2023**



LAMPIRAN III
NOMOR : KP - DJKA 68 TAHUN 2023
TANGGAL : 14 APRIL 2023



DAFTAR WAKTU KERETA API

**Jaringan Jalur Kereta Api Nasional
Di Sumatera Bagian Utara**

Berlaku Pada GAPEKA 2023

KANTOR PUSAT
BANDUNG 2023

PT KERETA API INDONESIA (PERSERO)

DAFTAR ISI

NOMOR		KELAS KA	NAMA KA	LINTAS	JAM		HAL
URT	KA				BRK	DAT	
1	U1	KA BANDARA	Bandara Kualanamu	KNM - MDN	05.20	05.56	2
2	U2	KA BANDARA	Bandara Kualanamu	MDN - KNM	04.00	04.38	
3	U3	KA BANDARA	Bandara Kualanamu	KNM - MDN	06.00	06.36	
4	U4	KA BANDARA	Bandara Kualanamu	MDN - KNM	05.00	05.38	
5	U5	KA BANDARA	Bandara Kualanamu	KNM - MDN	06.50	07.26	
6	U6	KA BANDARA	Bandara Kualanamu	MDN - KNM	06.00	06.38	
7	U7	KA BANDARA	Bandara Kualanamu	KNM - MDN	07.45	08.21	3
8	U8	KA BANDARA	Bandara Kualanamu	MDN - KNM	06.35	07.11	
9	U9	KA BANDARA	Bandara Kualanamu	KNM - MDN	08.15	08.51	
10	U10	KA BANDARA	Bandara Kualanamu	MDN - KNM	07.25	08.01	
11	U11	KA BANDARA	Bandara Kualanamu	KNM - MDN	08.40	09.16	
12	U12	KA BANDARA	Bandara Kualanamu	MDN - KNM	07.50	08.26	4
13	U13	KA BANDARA	Bandara Kualanamu	KNM - MDN	09.40	10.16	
14	U14	KA BANDARA	Bandara Kualanamu	MDN - KNM	08.45	09.21	
15	U15	KA BANDARA	Bandara Kualanamu	KNM - MDN	10.05	10.41	
16	U16	KA BANDARA	Bandara Kualanamu	MDN - KNM	09.10	09.46	5
17	U17	KA BANDARA	Bandara Kualanamu	KNM - MDN	10.45	11.21	
18	U18	KA BANDARA	Bandara Kualanamu	MDN - KNM	09.45	10.21	
19	U19	KA BANDARA	Bandara Kualanamu	KNM - MDN	11.40	12.16	
20	U20	KA BANDARA	Bandara Kualanamu	MDN - KNM	10.50	11.26	6
21	U21	KA BANDARA	Bandara Kualanamu	KNM - MDN	12.30	13.06	
22	U22	KA BANDARA	Bandara Kualanamu	MDN - KNM	11.15	11.51	
23	U23	KA BANDARA	Bandara Kualanamu	KNM - MDN	13.20	13.56	
24	U24	KA BANDARA	Bandara Kualanamu	MDN - KNM	11.45	12.21	
25	U25	KA BANDARA	Bandara Kualanamu	KNM - MDN	13.45	14.21	
26	U26	KA BANDARA	Bandara Kualanamu	MDN - KNM	12.35	13.11	
27	U27	KA BANDARA	Bandara Kualanamu	KNM - MDN	14.30	15.06	7
28	U28	KA BANDARA	Bandara Kualanamu	MDN - KNM	13.25	14.01	
29	U29	KA BANDARA	Bandara Kualanamu	KNM - MDN	14.55	15.31	
30	U30	KA BANDARA	Bandara Kualanamu	MDN - KNM	14.10	14.46	
31	U31	KA BANDARA	Bandara Kualanamu	KNM - MDN	15.45	16.21	
32	U32	KA BANDARA	Bandara Kualanamu	MDN - KNM	14.35	15.11	8
33	U33	KA BANDARA	Bandara Kualanamu	KNM - MDN	16.20	16.56	
34	U34	KA BANDARA	Bandara Kualanamu	MDN - KNM	15.20	15.56	
35	U35	KA BANDARA	Bandara Kualanamu	KNM - MDN	17.05	17.41	
36	U36	KA BANDARA	Bandara Kualanamu	MDN - KNM	15.50	16.26	9
37	U37	KA BANDARA	Bandara Kualanamu	KNM - MDN	17.30	18.06	
38	U38	KA BANDARA	Bandara Kualanamu	MDN - KNM	16.45	17.21	
39	U39	KA BANDARA	Bandara Kualanamu	KNM - MDN	18.05	18.41	
40	U40	KA BANDARA	Bandara Kualanamu	MDN - KNM	17.10	17.46	
41	U41	KA BANDARA	Bandara Kualanamu	KNM - MDN	19.25	20.01	
42	U42	KA BANDARA	Bandara Kualanamu	MDN - KNM	18.10	18.46	10
43	U43	KA BANDARA	Bandara Kualanamu	KNM - MDN	19.55	20.31	
44	U44	KA BANDARA	Bandara Kualanamu	MDN - KNM	18.35	19.11	
45	U45	KA BANDARA	Bandara Kualanamu	KNM - MDN	20.35	21.13	
46	U46	KA BANDARA	Bandara Kualanamu	MDN - KNM	19.05	19.41	
47	U47	KA BANDARA	Bandara Kualanamu	KNM - MDN	21.10	21.48	11
48	U48	KA BANDARA	Bandara Kualanamu	MDN - KNM	20.20	20.56	
49	U49	KA BANDARA	Bandara Kualanamu	KNM - MDN	22.50	23.28	
50	U50	KA BANDARA	Bandara Kualanamu	MDN - KNM	21.15	21.51	

NOMOR		KELAS KA	NAMA KA	LINTAS	JAM		HAL
URT	KA				BRK	DAT	
51	U51	KA EKSEKUTIF BISNIS	Sribilah Utama	RAP - MDN	08.05	13.36	13
52	U52	KA EKSEKUTIF BISNIS	Sribilah Utama	MDN - RAP	08.15	13.57	
53	U53	KA EKSEKUTIF BISNIS	Sribilah Utama	RAP - MDN	14.45	20.20	14
54	U54	KA EKSEKUTIF BISNIS	Sribilah Utama	MDN - RAP	16.05	21.35	15
55	U55	KA EKSEKUTIF BISNIS	Sribilah Utama	RAP - MDN	22.30	03.44	16
56	U56	KA EKSEKUTIF BISNIS	Sribilah Utama	MDN - RAP	22.50	04.10	
57	U57F	KA EKSEKUTIF BISNIS	Sribilah Utama	RAP - MDN	17.05	22.43	17
58	U58F	KA EKSEKUTIF BISNIS	Sribilah Utama	MDN - RAP	10.25	16.18	18
59	U59F	KA BISNIS	Tanjung Balai Ekspres	TNB - MDN	07.00	11.06	21
60	U60F	KA BISNIS	Tanjung Balai Ekspres	MDN - TNB	17.30	21.13	
61	U61F	KA EKONOMI 80	Amir Hamzah	BSG - BIJ	08.30	10.58	24
62	U62F	KA EKONOMI 80	Amir Hamzah	BIJ - BSG	05.30	07.58	
63	U63F	KA EKONOMI 80	Amir Hamzah	BSG - BIJ	14.25	16.53	
64	U64F	KA EKONOMI 80	Amir Hamzah	BIJ - BSG	11.30	13.58	
65	U65F	KA EKONOMI 80	Amir Hamzah	BSG - BIJ	20.20	22.48	25
66	U66F	KA EKONOMI 80	Amir Hamzah	BIJ - BSG	17.20	19.48	
67	U67F	KA EKONOMI 80	Datuk Belambangan	LAG - TBI	08.25	09.40	27
68	U68F	KA EKONOMI 80	Datuk Belambangan	TBI - LAG	06.20	07.25	
69	U69F	KA EKONOMI 80	Datuk Belambangan	LAG - TBI	18.00	19.05	
70	U70F	KA EKONOMI 80	Datuk Belambangan	TBI - LAG	15.30	16.35	29
71	U101F	KA EKONOMI 80	Belawan Indah	MDN - BLW	04.50	05.28	
72	U102F	KA EKONOMI 80	Belawan Indah	BLW - MDN	06.03	06.45	
73	U103F	KA EKONOMI 80	Belawan Indah	MDN - BLW	18.30	19.08	
74	U104F	KA EKONOMI 80	Belawan Indah	BLW - MDN	19.30	20.08	31
75	U71	KA EKONOMI 106	Putri Deli	TNB - MDN	08.20	12.41	
76	U72	KA EKONOMI 106	Putri Deli	MDN - TNB	07.10	11.30	32
77	U73	KA EKONOMI 106	Putri Deli	TNB - MDN	12.30	16.43	
78	U74	KA EKONOMI 106	Putri Deli	MDN - TNB	12.50	17.04	33
79	U75	KA EKONOMI 106	Putri Deli	TNB - MDN	19.25	23.43	
80	U76	KA EKONOMI 106	Putri Deli	MDN - TNB	18.50	23.10	36
81	U77	KA EKONOMI 106	Siantar Ekspres	SIR - MDN	06.40	09.42	
82	U78	KA EKONOMI 106	Siantar Ekspres	MDN - SIR	12.05	14.48	
83	U79F	KA EKONOMI 106	Siantar Ekspres	SIR - MDN	15.20	18.22	
84	U80F	KA EKONOMI 106	Siantar Ekspres	MDN - SIR	20.35	23.17	37
85	U81	KA EKONOMI 106	Sri Lelawangsa	BIJ - MDN	04.50	05.12	
86	U82	KA EKONOMI 106	Sri Lelawangsa	MDN - BIJ	04.05	04.27	39
87	U83	KA EKONOMI 106	Sri Lelawangsa	KBG - MDN	06.45	07.32	
88	U84	KA EKONOMI 106	Sri Lelawangsa	MDN - KBG	05.35	06.18	
89	U85	KA EKONOMI 106	Sri Lelawangsa	BIJ - MDN	08.45	09.07	
90	U86	KA EKONOMI 106	Sri Lelawangsa	MDN - BIJ	08.00	08.22	
91	U87	KA EKONOMI 106	Sri Lelawangsa	BIJ - MDN	10.15	10.37	
92	U88	KA EKONOMI 106	Sri Lelawangsa	MDN - BIJ	09.30	09.52	
93	U89	KA EKONOMI 106	Sri Lelawangsa	BIJ - MDN	11.50	12.12	40
94	U90	KA EKONOMI 106	Sri Lelawangsa	MDN - BIJ	11.00	11.22	
95	U91	KA EKONOMI 106	Sri Lelawangsa	BIJ - MDN	14.45	15.07	
96	U92	KA EKONOMI 106	Sri Lelawangsa	MDN - BIJ	14.00	14.22	
97	U93	KA EKONOMI 106	Sri Lelawangsa	BIJ - MDN	16.30	16.52	
98	U94	KA EKONOMI 106	Sri Lelawangsa	MDN - BIJ	15.30	15.52	
99	U95	KA EKONOMI 106	Sri Lelawangsa	KBG - MDN	18.25	19.09	
100	U96	KA EKONOMI 106	Sri Lelawangsa	MDN - KBG	17.15	17.59	41
101	U97	KA EKONOMI 106	Sri Lelawangsa	BIJ - MDN	20.30	20.52	
102	U98	KA EKONOMI 106	Sri Lelawangsa	MDN - BIJ	19.35	19.57	
103	U99	KA EKONOMI 106	Sri Lelawangsa	BIJ - MDN	22.15	22.37	
104	U100	KA EKONOMI 106	Sri Lelawangsa	MDN - BIJ	21.25	21.47	

NOMOR		KELAS KA	NAMA KA	LINTAS	JAM		HAL
URT	KA				BRK	DAT	
105	U105	KRD EKONOMI	Cut Meutia	KBL - KRG	08.35	09.38	43
106	U106	KRD EKONOMI	Cut Meutia	KRG - KBL	07.20	08.23	
107	U107	KRD EKONOMI	Cut Meutia	KBL - KRG	11.05	12.08	
108	U108	KRD EKONOMI	Cut Meutia	KRG - KBL	09.50	10.53	
109	U109	KRD EKONOMI	Cut Meutia	KBL - KRG	15.05	16.08	
110	U110	KRD EKONOMI	Cut Meutia	KRG - KBL	13.50	14.53	
111	U111	KRD EKONOMI	Cut Meutia	KBL - BKH	17.35	18.21	44
112	U112	KRD EKONOMI	Cut Meutia	KRG - KBL	16.20	17.23	
113	2801	KA BARANG BBM	Sitarbu Ekspres	SIR - LBU	12.35	16.49	46
114	2802	KA BARANG BBM	Sitarbu Ekspres	LBU - SIR	00.15	05.25	
115	2803	KA BARANG BBM	Kisarbu Ekspres	KIS - LBU	14.50	20.20	
116	2804	KA BARANG BBM	Kisarbu Ekspres	LBU - KIS	01.18	06.46	47
117	2813	KA BARANG CPO	Tebel CPO	TBI - BLW	21.11	01.25	50
118	2814	KA BARANG CPO	Tebel CPO	BLW - TBI	23.22	02.42	
119	2815	KA BARANG CPO	Pranabel CPO	PRA - BLW	22.10	03.09	
120	2816	KA BARANG CPO	Pranabel CPO	BLW - PRA	02.00	06.36	51
121	2817	KA BARANG CPO	Kisabel Cpo	KIS - BLW	17.45	23.20	
122	2818	KA BARANG CPO	Kisabel Cpo	BLW - KIS	08.00	14.42	52
123	2819	KA BARANG CPO	Pahabel CPO	PHA - BLW	18.15	02.30	53
124	2820	KA BARANG CPO	Pahabel CPO	BLW - PHA	21.00	05.30	
125	2821	KA BARANG CPO	Ranpabel CPO	RAP - BLW	18.50	03.49	54
126	2822	KA BARANG CPO	Ranpabel CPO	BLW - RAP	22.18	07.10	55
127	2823	KA BARANG CPO	Ranpabel CPO	RAP - BLW	20.00	05.43	56
128	2824	KA BARANG CPO	Ranpabel CPO	BLW - RAP	00.30	09.12	57
129	2825	KA BARANG CPO	Purjakis CPO	PUR - KIS	14.52	15.55	58
130	2826	KA BARANG CPO	Purjakis CPO	KIS - PUR	08.05	09.14	
131	2827	KA BARANG CPO	Siberkis CPO	KIS - SBJ	15.05	16.05	
132	2828	KA BARANG CPO	Siberkis CPO	SBJ - KIS	16.35	16.58	
133	2829	KA BARANG CPO	Dolbing CPO	DMR - TBI	17.40	18.23	
134	2830	KA BARANG CPO	Dolbing CPO	TBI - DMR	06.05	06.48	
135	2831F	KA BARANG CPO	Ranbaku Cpo	RAP - BDT	23.20	03.34	59
136	2832F	KA BARANG CPO	Ranbaku Cpo	BDT - KTJ	03.59	04.43	
137	2833F	KA BARANG CPO	Ranbaku Cpo	KTJ - BDT	05.15	06.10	
138	2834F	KA BARANG CPO	Ranbaku Cpo	BDT - RAP	06.35	11.51	60
139	2835F	KA BARANG CPO	Ranbaku Cpo	RAP - BDT	00.15	04.37	
140	2836F	KA BARANG CPO	Ranbaku Cpo	BDT - KTJ	05.02	05.43	
141	2837F	KA BARANG CPO	Ranbaku Cpo	KTJ - BDT	06.20	07.17	61
142	2838F	KA BARANG CPO	Ranbaku Cpo	BDT - RAP	07.42	12.48	
143	2811	KA BARANG CPO	Perbabel Cpo	PBA - BLW	14.12	16.18	62
144	2812	KA BARANG CPO	Perbabel Cpo	BLW - PBA	05.30	07.52	
145	2841	KA BARANG PETIKEMAS	Praba Cargo	PRA - BLW	16.50	20.48	64
146	2842	KA BARANG PETIKEMAS	Praba Cargo	BLW - PRA	02.40	07.17	
147	2843	KA BARANG PETIKEMAS	Sitabel Cargo	SIR - BLW	11.05	15.28	65
148	2844	KA BARANG PETIKEMAS	Sitabel Cargo	BLW - SIR	03.20	10.30	
149	2845F	KA BARANG PETIKEMAS	Ranba Cargo	RAP - BLW	20.45	06.28	
150	2846F	KA BARANG PETIKEMAS	Ranba Cargo	BLW - RAP	06.45	15.33	66
151	2847F	KA BARANG PETIKEMAS	Prakuta Cargo	PRA - BDT	11.25	11.47	67
152	2848F	KA BARANG PETIKEMAS	Prakuta Cargo	BDT - KTJ	13.20	14.05	
153	2849F	KA BARANG PETIKEMAS	Prakuta Cargo	KTJ - BDT	18.20	19.04	68
154	2850F	KA BARANG PETIKEMAS	Prakuta Cargo	BDT - PRA	20.34	20.53	
155	2851F	KA BARANG PETIKEMAS	Utaba Cargo	KTJ - BLW	17.10	22.16	
156	2852F	KA BARANG PETIKEMAS	Utaba Cargo	BLW - KTJ	04.25	09.49	

PT. KERETA API INDONESIA (Persero)

KANTOR PUSAT - BANDUNG

Toka: 12310, 12320, 12321, 12311 Fax: -

DAFTAR WAKTU

Berlaku pada Gapeka 2023

ISI:

- KA U1 (Bandara Kualanamu) Relasi KNM - MDN
KA U2 (Bandara Kualanamu) Relasi MDN - KNM
KA U3 (Bandara Kualanamu) Relasi KNM - MDN
KA U4 (Bandara Kualanamu) Relasi MDN - KNM
KA U5 (Bandara Kualanamu) Relasi KNM - MDN
KA U6 (Bandara Kualanamu) Relasi MDN - KNM
KA U7 (Bandara Kualanamu) Relasi KNM - MDN
KA U8 (Bandara Kualanamu) Relasi MDN - KNM
KA U9 (Bandara Kualanamu) Relasi KNM - MDN
KA U10 (Bandara Kualanamu) Relasi MDN - KNM
KA U11 (Bandara Kualanamu) Relasi KNM - MDN
KA U12 (Bandara Kualanamu) Relasi MDN - KNM
KA U13 (Bandara Kualanamu) Relasi KNM - MDN
KA U14 (Bandara Kualanamu) Relasi MDN - KNM
KA U15 (Bandara Kualanamu) Relasi KNM - MDN
KA U16 (Bandara Kualanamu) Relasi MDN - KNM
KA U17 (Bandara Kualanamu) Relasi KNM - MDN
KA U18 (Bandara Kualanamu) Relasi MDN - KNM
KA U19 (Bandara Kualanamu) Relasi KNM - MDN
KA U20 (Bandara Kualanamu) Relasi MDN - KNM
KA U21 (Bandara Kualanamu) Relasi KNM - MDN
KA U22 (Bandara Kualanamu) Relasi MDN - KNM
KA U23 (Bandara Kualanamu) Relasi KNM - MDN
KA U24 (Bandara Kualanamu) Relasi MDN - KNM
KA U25 (Bandara Kualanamu) Relasi KNM - MDN
KA U26 (Bandara Kualanamu) Relasi MDN - KNM
KA U27 (Bandara Kualanamu) Relasi KNM - MDN
KA U28 (Bandara Kualanamu) Relasi MDN - KNM
KA U29 (Bandara Kualanamu) Relasi KNM - MDN
KA U30 (Bandara Kualanamu) Relasi MDN - KNM
KA U31 (Bandara Kualanamu) Relasi KNM - MDN
KA U32 (Bandara Kualanamu) Relasi MDN - KNM
KA U33 (Bandara Kualanamu) Relasi KNM - MDN
KA U34 (Bandara Kualanamu) Relasi MDN - KNM
KA U35 (Bandara Kualanamu) Relasi KNM - MDN
KA U36 (Bandara Kualanamu) Relasi MDN - KNM
KA U37 (Bandara Kualanamu) Relasi KNM - MDN
KA U38 (Bandara Kualanamu) Relasi MDN - KNM
KA U39 (Bandara Kualanamu) Relasi KNM - MDN
KA U40 (Bandara Kualanamu) Relasi MDN - KNM
KA U41 (Bandara Kualanamu) Relasi KNM - MDN
KA U42 (Bandara Kualanamu) Relasi MDN - KNM
KA U43 (Bandara Kualanamu) Relasi KNM - MDN
KA U44 (Bandara Kualanamu) Relasi MDN - KNM
KA U45 (Bandara Kualanamu) Relasi KNM - MDN
KA U46 (Bandara Kualanamu) Relasi MDN - KNM
KA U47 (Bandara Kualanamu) Relasi KNM - MDN
KA U48 (Bandara Kualanamu) Relasi MDN - KNM
KA U49 (Bandara Kualanamu) Relasi KNM - MDN
KA U50 (Bandara Kualanamu) Relasi MDN - KNM

2. EKSEKUTIF

- Untuk keperluan angkutan penumpang
- Puncak kecepatan lintas:

KNM - MDN = 90 Km/Jam

- KA tersebut perjalanannya sesuai dengan GAPEKA.
- EVP / VP, Manager Op, Manager Sarana Divre 1 Mdn, atur dinas lok rangkaian dan awak KA-nya.
- Memberhentikan luar biasa (BLB) suatu KA harus sesuai dengan PD 19 jilid 1 pasal 86.

KA U1 (Bandara Kualanamu) Relasi KNM-MDN

No.	Stasiun dan Perhentian	Datang	Berangkat	Keterangan
1	Kualanamu (KNM)		05:20:00	
2	Araskabu (ARB)	Ls	05:26:00	
3	Batang Kuis (BTK)	05:34:00	05:36:00	
4	Bandar Kalipah (BAP)	05:44:00	05:46:00	
5	Medan (MDN)	05:56:00		

KA U2 (Bandara Kualanamu) Relasi MDN-KNM

No.	Stasiun dan Perhentian	Datang	Berangkat	Keterangan
1	Medan (MDN)		04:00:00	X KA U55
2	Bandar Kalipah (BAP)	04:12:00	04:14:00	
3	Batang Kuis (BTK)	04:22:00	04:24:00	
4	Araskabu (ARB)	Ls	04:32:00	
5	Kualanamu (KNM)	04:38:00		

KA U3 (Bandara Kualanamu) Relasi KNM-MDN

No.	Stasiun dan Perhentian	Datang	Berangkat	Keterangan
1	Kualanamu (KNM)		06:00:00	
2	Araskabu (ARB)	Ls	06:06:00	
3	Batang Kuis (BTK)	06:14:00	06:16:00	
4	Bandar Kalipah (BAP)	06:24:00	06:26:00	
5	Medan (MDN)	06:36:00		

KA U4 (Bandara Kualanamu) Relasi MDN-KNM

No.	Stasiun dan Perhentian	Datang	Berangkat	Keterangan
1	Medan (MDN)		05:00:00	X KA 2823
2	Bandar Kalipah (BAP)	05:12:00	05:14:00	
3	Batang Kuis (BTK)	05:22:00	05:24:00	
4	Araskabu (ARB)	Ls	05:32:00	
5	Kualanamu (KNM)	05:38:00		

KA U5 (Bandara Kualanamu) Relasi KNM-MDN

No.	Stasiun dan Perhentian	Datang	Berangkat	Keterangan
1	Kualanamu (KNM)		06:50:00	
2	Araskabu (ARB)	Ls	06:56:00	
3	Batang Kuis (BTK)	07:04:00	07:06:00	
4	Bandar Kalipah (BAP)	07:14:00	07:16:00	
5	Medan (MDN)	07:26:00		

KA U6 (Bandara Kualanamu) Relasi MDN-KNM

No.	Stasiun dan Perhentian	Datang	Berangkat	Keterangan
1	Medan (MDN)		06:00:00	X KA 2845F JJ
2	Bandar Kalipah (BAP)	06:12:00	06:14:00	
3	Batang Kuis (BTK)	06:22:00	06:24:00	
4	Araskabu (ARB)	Ls	06:32:00	
5	Kualanamu (KNM)	06:38:00		

KA U7 (Bandara Kualanamu) Relasi KNM-MDN

No.	Stasiun dan Perhentian	Datang	Berangkat	Keterangan
1	Kualanamu (KNM)		07:45:00	
2	Araskabu (ARB)	Ls	07:51:00	
3	Batang Kuis (BTK)	07:59:00	08:01:00	
4	Bandar Kalipah (BAP)	08:09:00	08:11:00	
5	Medan (MDN)	08:21:00		

KA U8 (Bandara Kualanamu) Relasi MDN-KNM

No.	Stasiun dan Perhentian	Datang	Berangkat	Keterangan
1	Medan (MDN)		06:35:00	
2	Bandar Kalipah (BAP)	06:45:00	06:47:00	
3	Batang Kuis (BTK)	06:55:00	06:57:00	
4	Araskabu (ARB)	Ls	07:05:00	
5	Kualanamu (KNM)	07:11:00		

KA U9 (Bandara Kualanamu) Relasi KNM-MDN

No.	Stasiun dan Perhentian	Datang	Berangkat	Keterangan
1	Kualanamu (KNM)		08:15:00	
2	Araskabu (ARB)	Ls	08:21:00	
3	Batang Kuis (BTK)	08:29:00	08:31:00	
4	Bandar Kalipah (BAP)	08:39:00	08:41:00	
5	Medan (MDN)	08:51:00		

KA U10 (Bandara Kualanamu) Relasi MDN-KNM

No.	Stasiun dan Perhentian	Datang	Berangkat	Keterangan
1	Medan (MDN)		07:25:00	
2	Bandar Kalipah (BAP)	07:35:00	07:37:00	
3	Batang Kuis (BTK)	07:45:00	07:47:00	
4	Araskabu (ARB)	Ls	07:55:00	
5	Kualanamu (KNM)	08:01:00		

KA U11 (Bandara Kualanamu) Relasi KNM-MDN

No.	Stasiun dan Perhentian	Datang	Berangkat	Keterangan
1	Kualanamu (KNM)		08:40:00	
2	Araskabu (ARB)	Ls	08:46:00	

No.	Stasiun dan Perhentian	Datang	Berangkat	Keterangan
3	Batang Kuis (BTK)	08:54:00	08:56:00	
4	Bandar Kalipah (BAP)	09:04:00	09:06:00	
5	Medan (MDN)	09:16:00		

KA U12 (Bandara Kualanamu) Relasi MDN-KNM

No.	Stasiun dan Perhentian	Datang	Berangkat	Keterangan
1	Medan (MDN)		07:50:00	
2	Bandar Kalipah (BAP)	08:00:00	08:02:00	// KA 2846F JJ (KA 2846F JJ =)
3	Batang Kuis (BTK)	08:10:00	08:12:00	
4	Araskabu (ARB)	Ls	08:20:00	
5	Kualanamu (KNM)	08:26:00		

KA U13 (Bandara Kualanamu) Relasi KNM-MDN

No.	Stasiun dan Perhentian	Datang	Berangkat	Keterangan
1	Kualanamu (KNM)		09:40:00	
2	Araskabu (ARB)	Ls	09:46:00	
3	Batang Kuis (BTK)	09:54:00	09:56:00	
4	Bandar Kalipah (BAP)	10:04:00	10:06:00	
5	Medan (MDN)	10:16:00		

KA U14 (Bandara Kualanamu) Relasi MDN-KNM

No.	Stasiun dan Perhentian	Datang	Berangkat	Keterangan
1	Medan (MDN)		08:45:00	
2	Bandar Kalipah (BAP)	08:55:00	08:57:00	
3	Batang Kuis (BTK)	09:05:00	09:07:00	
4	Araskabu (ARB)	Ls	09:15:00	
5	Kualanamu (KNM)	09:21:00		

KA U15 (Bandara Kualanamu) Relasi KNM-MDN

No.	Stasiun dan Perhentian	Datang	Berangkat	Keterangan
1	Kualanamu (KNM)		10:05:00	
2	Araskabu (ARB)	Ls	10:11:00	
3	Batang Kuis (BTK)	10:19:00	10:21:00	
4	Bandar Kalipah (BAP)	10:29:00	10:31:00	
5	Medan (MDN)	10:41:00		

KA U16 (Bandara Kualanamu) Relasi MDN-KNM

No.	Stasiun dan Perhentian	Datang	Berangkat	Keterangan
1	Medan (MDN)		09:10:00	
2	Bandar Kalipah (BAP)	09:20:00	09:22:00	// KA 2818 (KA 2818 =)
3	Batang Kuis (BTK)	09:30:00	09:32:00	
4	Araskabu (ARB)	Ls	09:40:00	

No.	Stasiun dan Perhentian	Datang	Berangkat	Keterangan
5	Kualanamu (KNM)	09:46:00		

KA U17 (Bandara Kualanamu) Relasi KNM-MDN

No.	Stasiun dan Perhentian	Datang	Berangkat	Keterangan
1	Kualanamu (KNM)		10:45:00	
2	Araskabu (ARB)	Ls	10:51:00	
3	Batang Kuis (BTK)	10:59:00	11:01:00	
4	Bandar Kalipah (BAP)	11:09:00	11:11:00	
5	Medan (MDN)	11:21:00		

KA U18 (Bandara Kualanamu) Relasi MDN-KNM

No.	Stasiun dan Perhentian	Datang	Berangkat	Keterangan
1	Medan (MDN)		09:45:00	
2	Bandar Kalipah (BAP)	09:55:00	09:57:00	
3	Batang Kuis (BTK)	10:05:00	10:07:00	
4	Araskabu (ARB)	Ls	10:15:00	
5	Kualanamu (KNM)	10:21:00		

KA U19 (Bandara Kualanamu) Relasi KNM-MDN

No.	Stasiun dan Perhentian	Datang	Berangkat	Keterangan
1	Kualanamu (KNM)		11:40:00	
2	Araskabu (ARB)	Ls	11:46:00	
3	Batang Kuis (BTK)	11:54:00	11:56:00	
4	Bandar Kalipah (BAP)	12:04:00	12:06:00	
5	Medan (MDN)	12:16:00		

KA U20 (Bandara Kualanamu) Relasi MDN-KNM

No.	Stasiun dan Perhentian	Datang	Berangkat	Keterangan
1	Medan (MDN)		10:50:00	
2	Bandar Kalipah (BAP)	11:00:00	11:02:00	
3	Batang Kuis (BTK)	11:10:00	11:12:00	
4	Araskabu (ARB)	Ls	11:20:00	
5	Kualanamu (KNM)	11:26:00		

KA U21 (Bandara Kualanamu) Relasi KNM-MDN

No.	Stasiun dan Perhentian	Datang	Berangkat	Keterangan
1	Kualanamu (KNM)		12:30:00	
2	Araskabu (ARB)	Ls	12:36:00	
3	Batang Kuis (BTK)	12:44:00	12:46:00	
4	Bandar Kalipah (BAP)	12:54:00	12:56:00	
5	Medan (MDN)	13:06:00		

KA U22 (Bandara Kualanamu) Relasi MDN-KNM

No.	Stasiun dan Perhentian	Datang	Berangkat	Keterangan
1	Medan (MDN)		11:15:00	
2	Bandar Kalipah (BAP)	11:25:00	11:27:00	
3	Batang Kuis (BTK)	11:35:00	11:37:00	
4	Araskabu (ARB)	Ls	11:45:00	
5	Kualanamu (KNM)	11:51:00		

KA U23 (Bandara Kualanamu) Relasi KNM-MDN

No.	Stasiun dan Perhentian	Datang	Berangkat	Keterangan
1	Kualanamu (KNM)		13:20:00	
2	Araskabu (ARB)	Ls	13:26:00	
3	Batang Kuis (BTK)	13:34:00	13:36:00	
4	Bandar Kalipah (BAP)	13:44:00	13:46:00	
5	Medan (MDN)	13:56:00		

KA U24 (Bandara Kualanamu) Relasi MDN-KNM

No.	Stasiun dan Perhentian	Datang	Berangkat	Keterangan
1	Medan (MDN)		11:45:00	
2	Bandar Kalipah (BAP)	11:55:00	11:57:00	
3	Batang Kuis (BTK)	12:05:00	12:07:00	
4	Araskabu (ARB)	Ls	12:15:00	
5	Kualanamu (KNM)	12:21:00		

KA U25 (Bandara Kualanamu) Relasi KNM-MDN

No.	Stasiun dan Perhentian	Datang	Berangkat	Keterangan
1	Kualanamu (KNM)		13:45:00	
2	Araskabu (ARB)	Ls	13:51:00	// KA 2843 (KA 2843 =)
3	Batang Kuis (BTK)	13:59:00	14:01:00	
4	Bandar Kalipah (BAP)	14:09:00	14:11:00	
5	Medan (MDN)	14:21:00		

KA U26 (Bandara Kualanamu) Relasi MDN-KNM

No.	Stasiun dan Perhentian	Datang	Berangkat	Keterangan
1	Medan (MDN)		12:35:00	
2	Bandar Kalipah (BAP)	12:45:00	12:47:00	
3	Batang Kuis (BTK)	12:55:00	12:57:00	
4	Araskabu (ARB)	Ls	13:05:00	
5	Kualanamu (KNM)	13:11:00		

KA U27 (Bandara Kualanamu) Relasi KNM-MDN

No.	Stasiun dan Perhentian	Datang	Berangkat	Keterangan
1	Kualanamu (KNM)		14:30:00	
2	Araskabu (ARB)	Ls	14:36:00	// KA 2811 (KA 2811 =)
3	Batang Kuis (BTK)	14:44:00	14:46:00	
4	Bandar Kalipah (BAP)	14:54:00	14:56:00	
5	Medan (MDN)	15:06:00		

KA U28 (Bandara Kualanamu) Relasi MDN-KNM

No.	Stasiun dan Perhentian	Datang	Berangkat	Keterangan
1	Medan (MDN)		13:25:00	
2	Bandar Kalipah (BAP)	13:35:00	13:37:00	
3	Batang Kuis (BTK)	13:45:00	13:47:00	
4	Araskabu (ARB)	Ls	13:55:00	
5	Kualanamu (KNM)	14:01:00		

KA U29 (Bandara Kualanamu) Relasi KNM-MDN

No.	Stasiun dan Perhentian	Datang	Berangkat	Keterangan
1	Kualanamu (KNM)		14:55:00	
2	Araskabu (ARB)	Ls	15:01:00	
3	Batang Kuis (BTK)	15:09:00	15:11:00	
4	Bandar Kalipah (BAP)	15:19:00	15:21:00	
5	Medan (MDN)	15:31:00		

KA U30 (Bandara Kualanamu) Relasi MDN-KNM

No.	Stasiun dan Perhentian	Datang	Berangkat	Keterangan
1	Medan (MDN)		14:10:00	
2	Bandar Kalipah (BAP)	14:20:00	14:22:00	
3	Batang Kuis (BTK)	14:30:00	14:32:00	
4	Araskabu (ARB)	Ls	14:40:00	
5	Kualanamu (KNM)	14:46:00		

KA U31 (Bandara Kualanamu) Relasi KNM-MDN

No.	Stasiun dan Perhentian	Datang	Berangkat	Keterangan
1	Kualanamu (KNM)		15:45:00	
2	Araskabu (ARB)	Ls	15:51:00	
3	Batang Kuis (BTK)	15:59:00	16:01:00	
4	Bandar Kalipah (BAP)	16:09:00	16:11:00	
5	Medan (MDN)	16:21:00		

KA U32 (Bandara Kualanamu) Relasi MDN-KNM

No.	Stasiun dan Perhentian	Datang	Berangkat	Keterangan
1	Medan (MDN)		14:35:00	
2	Bandar Kalipah (BAP)	14:45:00	14:47:00	

No.	Stasiun dan Perhentian	Datang	Berangkat	Keterangan
3	Batang Kuis (BTK)	14:55:00	14:57:00	
4	Araskabu (ARB)	Ls	15:05:00	
5	Kualanamu (KNM)	15:11:00		

KA U33 (Bandara Kualanamu) Relasi KNM-MDN

No.	Stasiun dan Perhentian	Datang	Berangkat	Keterangan
1	Kualanamu (KNM)		16:20:00	
2	Araskabu (ARB)	Ls	16:26:00	
3	Batang Kuis (BTK)	16:34:00	16:36:00	
4	Bandar Kalipah (BAP)	16:44:00	16:46:00	
5	Medan (MDN)	16:56:00		

KA U34 (Bandara Kualanamu) Relasi MDN-KNM

No.	Stasiun dan Perhentian	Datang	Berangkat	Keterangan
1	Medan (MDN)		15:20:00	
2	Bandar Kalipah (BAP)	15:30:00	15:32:00	
3	Batang Kuis (BTK)	15:40:00	15:42:00	
4	Araskabu (ARB)	Ls	15:50:00	
5	Kualanamu (KNM)	15:56:00		

KA U35 (Bandara Kualanamu) Relasi KNM-MDN

No.	Stasiun dan Perhentian	Datang	Berangkat	Keterangan
1	Kualanamu (KNM)		17:05:00	
2	Araskabu (ARB)	Ls	17:11:00	
3	Batang Kuis (BTK)	17:19:00	17:21:00	
4	Bandar Kalipah (BAP)	17:29:00	17:31:00	
5	Medan (MDN)	17:41:00		

KA U36 (Bandara Kualanamu) Relasi MDN-KNM

No.	Stasiun dan Perhentian	Datang	Berangkat	Keterangan
1	Medan (MDN)		15:50:00	
2	Bandar Kalipah (BAP)	16:00:00	16:02:00	
3	Batang Kuis (BTK)	16:10:00	16:12:00	
4	Araskabu (ARB)	Ls	16:20:00	
5	Kualanamu (KNM)	16:26:00		

KA U37 (Bandara Kualanamu) Relasi KNM-MDN

No.	Stasiun dan Perhentian	Datang	Berangkat	Keterangan
1	Kualanamu (KNM)		17:30:00	
2	Araskabu (ARB)	Ls	17:36:00	
3	Batang Kuis (BTK)	17:44:00	17:46:00	
4	Bandar Kalipah (BAP)	17:54:00	17:56:00	

No.	Stasiun dan Perhentian	Datang	Berangkat	Keterangan
5	Medan (MDN)	18:06:00		

KA U38 (Bandara Kualanamu) Relasi MDN-KNM

No.	Stasiun dan Perhentian	Datang	Berangkat	Keterangan
1	Medan (MDN)		16:45:00	
2	Bandar Kalipah (BAP)	16:55:00	16:57:00	
3	Batang Kuis (BTK)	17:05:00	17:07:00	
4	Araskabu (ARB)	Ls	17:15:00	
5	Kualanamu (KNM)	17:21:00		

KA U39 (Bandara Kualanamu) Relasi KNM-MDN

No.	Stasiun dan Perhentian	Datang	Berangkat	Keterangan
1	Kualanamu (KNM)		18:05:00	
2	Araskabu (ARB)	Ls	18:11:00	
3	Batang Kuis (BTK)	18:19:00	18:21:00	
4	Bandar Kalipah (BAP)	18:29:00	18:31:00	
5	Medan (MDN)	18:41:00		

KA U40 (Bandara Kualanamu) Relasi MDN-KNM

No.	Stasiun dan Perhentian	Datang	Berangkat	Keterangan
1	Medan (MDN)		17:10:00	
2	Bandar Kalipah (BAP)	17:20:00	17:22:00	
3	Batang Kuis (BTK)	17:30:00	17:32:00	
4	Araskabu (ARB)	Ls	17:40:00	
5	Kualanamu (KNM)	17:46:00		

KA U41 (Bandara Kualanamu) Relasi KNM-MDN

No.	Stasiun dan Perhentian	Datang	Berangkat	Keterangan
1	Kualanamu (KNM)		19:25:00	
2	Araskabu (ARB)	Ls	19:31:00	
3	Batang Kuis (BTK)	19:39:00	19:41:00	
4	Bandar Kalipah (BAP)	19:49:00	19:51:00	
5	Medan (MDN)	20:01:00		

KA U42 (Bandara Kualanamu) Relasi MDN-KNM

No.	Stasiun dan Perhentian	Datang	Berangkat	Keterangan
1	Medan (MDN)		18:10:00	
2	Bandar Kalipah (BAP)	18:20:00	18:22:00	
3	Batang Kuis (BTK)	18:30:00	18:32:00	
4	Araskabu (ARB)	Ls	18:40:00	
5	Kualanamu (KNM)	18:46:00		

KA U43 (Bandara Kualanamu) Relasi KNM-MDN

No.	Stasiun dan Perhentian	Datang	Berangkat	Keterangan
1	Kualanamu (KNM)		19:55:00	
2	Araskabu (ARB)	Ls	20:01:00	
3	Batang Kuis (BTK)	20:09:00	20:11:00	
4	Bandar Kalipah (BAP)	20:19:00	20:21:00	
5	Medan (MDN)	20:31:00		

KA U44 (Bandara Kualanamu) Relasi MDN-KNM

No.	Stasiun dan Perhentian	Datang	Berangkat	Keterangan
1	Medan (MDN)		18:35:00	
2	Bandar Kalipah (BAP)	18:45:00	18:47:00	
3	Batang Kuis (BTK)	18:55:00	18:57:00	
4	Araskabu (ARB)	Ls	19:05:00	
5	Kualanamu (KNM)	19:11:00		

KA U45 (Bandara Kualanamu) Relasi KNM-MDN

No.	Stasiun dan Perhentian	Datang	Berangkat	Keterangan
1	Kualanamu (KNM)		20:35:00	
2	Araskabu (ARB)	Ls	20:41:00	
3	Batang Kuis (BTK)	20:49:00	20:51:00	
4	Bandar Kalipah (BAP)	20:59:00	21:01:00	
5	Medan (MDN)	21:13:00		

KA U46 (Bandara Kualanamu) Relasi MDN-KNM

No.	Stasiun dan Perhentian	Datang	Berangkat	Keterangan
1	Medan (MDN)		19:05:00	
2	Bandar Kalipah (BAP)	19:15:00	19:17:00	
3	Batang Kuis (BTK)	19:25:00	19:27:00	
4	Araskabu (ARB)	Ls	19:35:00	
5	Kualanamu (KNM)	19:41:00		

KA U47 (Bandara Kualanamu) Relasi KNM-MDN

No.	Stasiun dan Perhentian	Datang	Berangkat	Keterangan
1	Kualanamu (KNM)		21:10:00	
2	Araskabu (ARB)	Ls	21:16:00	
3	Batang Kuis (BTK)	21:24:00	21:26:00	
4	Bandar Kalipah (BAP)	21:34:00	21:36:00	
5	Medan (MDN)	21:48:00		(KA 2820 X)

KA U48 (Bandara Kualanamu) Relasi MDN-KNM

No.	Stasiun dan Perhentian	Datang	Berangkat	Keterangan
1	Medan (MDN)		20:20:00	
2	Bandar Kalipah (BAP)	20:30:00	20:32:00	
3	Batang Kuis (BTK)	20:40:00	20:42:00	
4	Araskabu (ARB)	Ls	20:50:00	
5	Kualanamu (KNM)	20:56:00		

KA U49 (Bandara Kualanamu) Relasi KNM-MDN

No.	Stasiun dan Perhentian	Datang	Berangkat	Keterangan
1	Kualanamu (KNM)		22:50:00	
2	Araskabu (ARB)	Ls	22:56:00	
3	Batang Kuis (BTK)	23:04:00	23:06:00	
4	Bandar Kalipah (BAP)	23:14:00	23:16:00	
5	Medan (MDN)	23:28:00		(KA 2822 X)

KA U50 (Bandara Kualanamu) Relasi MDN-KNM

No.	Stasiun dan Perhentian	Datang	Berangkat	Keterangan
1	Medan (MDN)		21:15:00	
2	Bandar Kalipah (BAP)	21:25:00	21:27:00	
3	Batang Kuis (BTK)	21:35:00	21:37:00	
4	Araskabu (ARB)	Ls	21:45:00	
5	Kualanamu (KNM)	21:51:00		

A.N. Direktur Operasi
OMR

IQBAL T ISKANDAR
NIPP. 44330

PT. KERETA API INDONESIA (Persero)
KANTOR PUSAT - BANDUNG

Toka: 12310, 12320, 12321, 12311 Fax: -

DAFTAR WAKTU

Berlaku pada Gapeka 2023

ISI:

1. KA U51 (Sribilah Utama) Relasi RAP - MDN
KA U52 (Sribilah Utama) Relasi MDN - RAP
KA U53 (Sribilah Utama) Relasi RAP - MDN
KA U54 (Sribilah Utama) Relasi MDN - RAP
KA U55 (Sribilah Utama) Relasi RAP - MDN
KA U56 (Sribilah Utama) Relasi MDN - RAP
KA U57F (Sribilah Utama) Relasi RAP - MDN
KA U58F (Sribilah Utama) Relasi MDN - RAP
2. CAMPURAN (EKSE/BIS)
3. Untuk keperluan angkutan penumpang
4. Puncak kecepatan lintas:

RAP - MBU = 90 Km/Jam

MBU - MBM = 70 Km/Jam

MBM - KIS = 90 Km/Jam

KIS - PRA = 70 Km/Jam

PRA - TBI = 80 Km/Jam

TBI - MDN = 90 Km/Jam

5. KA tersebut perjalanannya sesuai dengan GAPEKA.
6. EVP / VP, Manager Op, Manager Sarana Divre 1 Mdn, atur dinasan lok rangkaian dan awak KA-nya.
7. Memberhentikan luar biasa (BLB) suatu KA harus sesuai dengan PD 19 jilid 1 pasal 86.

KA U51 (Sribilah Utama) Relasi RAP-MDN

No.	Stasiun dan Perhentian	Datang	Berangkat	Keterangan
1	Rantau Prapat (RAP)		08:05:00	
2	Marbau (MBU)	08:24:00	08:26:00	
3	Padang Halaban (PHA)	08:34:00	08:38:00	X KA 2824 (KA 2824 X)
4	Pamienke (PME)	Ls	08:50:00	
5	Situngir (SIU)	Ls	09:07:00	
6	Membang Muda (MBM)	09:17:00	09:19:00	
7	Aekloba (AKB)	Ls	09:29:00	
8	Puluraja (PUR)	09:35:00	09:37:00	
9	Teluk Dalam (TUK)	Ls	09:51:00	X KA 2834F JJ (KA 2834F JJ X)
10	Hengelo (HL)	Ls	09:55:00	
11	Kisaran (KIS)	10:09:00	10:19:00	X KA 2838F JJ (KA 2838F JJ X)
12	Bunut (BUU)	Ls	10:24:00	
13	Seibejangkar (SBJ)	Ls	10:37:00	X KA U72 (KA U72 X)
14	Dusun (DSU)	Ls	10:43:00	
15	Lima Puluh (LMP)	Ls	10:57:00	X KA U52 (KA U52 X)
16	Perlanaan (PRA)	11:05:00	11:08:00	
17	Bahlias (BLI)	Ls	11:14:00	
18	Bandar Tinggi (BDT)	Ls	11:27:00	X KA 2846F JJ (KA 2846F JJ X)
19	Laut Tador (LTD)	Ls	11:33:00	
20	Tebing Tinggi (TBI)	11:47:00	11:52:00	X KA 2818 (KA 2818 X)
21	Bamban (BMB)	Ls	12:04:00	X KA U58F JJ (KA U58F JJ X)
22	Rampah (RPH)	Ls	12:11:00	
23	Teluk Mengkudu (TKE)	Ls	12:18:00	
24	Lidah Tanah (LDT)	Ls	12:28:00	
25	Perbaungan (PBA)	Ls	12:35:00	
26	Lubuk Pakam (LBP)	12:44:00	12:50:00	X KA U78 (KA U78 X)
27	Araskabu (ARB)	12:58:00	13:07:00	
28	Batang Kuis (BTK)	Ls	13:15:00	
29	Bandar Kalipah (BAP)	13:22:00	13:24:00	
30	Medan (MDN)	13:36:00		

KA U52 (Sribilah Utama) Relasi MDN-RAP

No.	Stasiun dan Perhentian	Datang	Berangkat	Keterangan
1	Medan (MDN)		08:15:00	
2	Bandar Kalipah (BAP)	08:28:00	08:30:00	
3	Batang Kuis (BTK)	Ls	08:37:00	
4	Araskabu (ARB)	08:45:00	08:47:00	
5	Lubuk Pakam (LBP)	08:55:00	08:59:00	X KA U77 (KA U77 X) // KA 2846F JJ (KA 2846F JJ =)
6	Perbaungan (PBA)	09:09:00	09:11:00	
7	Lidah Tanah (LDT)	Ls	09:19:00	
8	Teluk Mengkudu (TKE)	Ls	09:28:00	

No.	Stasiun dan Perhentian	Datang	Berangkat	Keterangan
9	Rampah (RPH)	Ls	09:35:00	X KA U59F JJ (KA U59F JJ X)
10	Bamban (BMB)	Ls	09:41:00	
11	Tebing Tinggi (TBI)	09:53:00	09:58:00	X KA U67F JJ
12	Laut Tador (LTD)	Ls	10:12:00	
13	Bandar Tinggi (BDT)	Ls	10:18:00	X KA U71 (KA U71 X)
14	Bahlias (BLI)	Ls	10:30:00	
15	Perlanaan (PRA)	10:36:00	10:39:00	
16	Lima Puluh (LMP)	10:49:00	10:59:00	X KA U51 (KA U51 X)
17	Dusun (DSU)	Ls	11:14:00	
18	Seibejangkar (SBJ)	Ls	11:21:00	
19	Bunut (BUU)	Ls	11:35:00	
20	Kisaran (KIS)	11:40:00	11:50:00	
21	Hengelo (HL)	Ls	12:04:00	
22	Teluk Dalam (TUK)	Ls	12:08:00	
23	Puluraja (PUR)	12:22:00	12:24:00	
24	Aekloba (AKB)	Ls	12:30:00	
25	Membang Muda (MBM)	12:40:00	12:42:00	
26	Situngir (SIU)	Ls	12:53:00	
27	Pamienke (PME)	Ls	13:11:00	
28	Padang Halaban (PHA)	13:23:00	13:25:00	
29	Marbau (MBU)	13:35:00	13:37:00	
30	Rantau Prapat (RAP)	13:57:00		

KA U53 (Sribilah Utama) Relasi RAP-MDN

No.	Stasiun dan Perhentian	Datang	Berangkat	Keterangan
1	Rantau Prapat (RAP)		14:45:00	
2	Marbau (MBU)	15:05:00	15:07:00	X KA 2846F JJ (KA 2846F JJ X)
3	Padang Halaban (PHA)	15:17:00	15:19:00	
4	Pamienke (PME)	Ls	15:31:00	X KA U58F JJ (KA U58F JJ X)
5	Situngir (SIU)	Ls	15:49:00	
6	Membang Muda (MBM)	16:00:00	16:02:00	
7	Aekloba (AKB)	Ls	16:12:00	
8	Puluraja (PUR)	16:18:00	16:20:00	
9	Teluk Dalam (TUK)	Ls	16:34:00	
10	Hengelo (HL)	Ls	16:38:00	
11	Kisaran (KIS)	16:52:00	17:02:00	X KA 2828
12	Bunut (BUU)	Ls	17:07:00	
13	Seibejangkar (SBJ)	Ls	17:21:00	
14	Dusun (DSU)	Ls	17:28:00	
15	Lima Puluh (LMP)	Ls	17:41:00	
16	Perlanaan (PRA)	17:49:00	17:51:00	
17	Bahlias (BLI)	Ls	17:57:00	

No.	Stasiun dan Perhentian	Datang	Berangkat	Keterangan
18	Bandar Tinggi (BDT)	Ls	18:08:00	X KA U54 (KA U54 X) // KA 2851F JJ (KA 2851F JJ =)
19	Laut Tador (LTD)	Ls	18:14:00	
20	Tebing Tinggi (TBI)	18:27:00	18:32:00	
21	Bamban (BMB)	Ls	18:44:00	
22	Rampah (RPH)	Ls	18:51:00	X KA U60F JJ (KA U60F JJ X)
23	Teluk Mengkudu (TKE)	Ls	18:59:00	
24	Lidah Tanah (LDT)	Ls	19:09:00	
25	Perbaungan (PBA)	19:18:00	19:20:00	
26	Lubuk Pakam (LBP)	19:30:00	19:37:00	X KA U76 (KA U76 X)
27	Araskabu (ARB)	19:46:00	19:48:00	
28	Batang Kuis (BTK)	Ls	19:57:00	
29	Bandar Kalipah (BAP)	20:05:00	20:07:00	
30	Medan (MDN)	20:20:00		(KA U80F JJ X)

KA U54 (Sribilah Utama) Relasi MDN-RAP

No.	Stasiun dan Perhentian	Datang	Berangkat	Keterangan
1	Medan (MDN)		16:05:00	X KA 2801
2	Bandar Kalipah (BAP)	16:17:00	16:20:00	
3	Batang Kuis (BTK)	Ls	16:27:00	
4	Araskabu (ARB)	16:36:00	16:38:00	
5	Lubuk Pakam (LBP)	16:47:00	16:49:00	
6	Perbaungan (PBA)	Ls	16:59:00	
7	Lidah Tanah (LDT)	Ls	17:06:00	X KA U79F JJ (KA U79F JJ X)
8	Teluk Mengkudu (TKE)	Ls	17:14:00	
9	Rampah (RPH)	Ls	17:21:00	X KA 2803 (KA 2803 X)
10	Bamban (BMB)	Ls	17:27:00	
11	Tebing Tinggi (TBI)	17:38:00	17:42:00	X KA 2841 (KA 2841 X)
12	Laut Tador (LTD)	Ls	17:56:00	
13	Bandar Tinggi (BDT)	18:03:00	18:10:00	X KA U53 (KA U53, 2851F JJ X)
14	Bahlias (BLI)	Ls	18:22:00	
15	Perlanaan (PRA)	18:28:00	18:30:00	
16	Lima Puluh (LMP)	Ls	18:38:00	X KA 2817 (KA 2817 X)
17	Dusun (DSU)	Ls	18:51:00	
18	Seibejangkar (SBJ)	Ls	18:58:00	
19	Bunut (BUU)	Ls	19:12:00	
20	Kisaran (KIS)	19:17:00	19:27:00	X KA U57F JJ (KA U57F JJ X)
21	Hengelo (HL)	Ls	19:41:00	
22	Teluk Dalam (TUK)	Ls	19:45:00	X KA 2819 (KA 2819 X)
23	Puluraja (PUR)	20:00:00	20:02:00	
24	Aekloba (AKB)	Ls	20:08:00	
25	Membang Muda (MBM)	20:18:00	20:20:00	X KA 2821 (KA 2821 X)
26	Situngir (SIU)	Ls	20:31:00	

No.	Stasiun dan Perhentian	Datang	Berangkat	Keterangan
27	Pamienke (PME)	Ls	20:49:00	X KA 2823 (KA 2823 X)
28	Padang Halaban (PHA)	21:01:00	21:03:00	
29	Marbau (MBU)	21:13:00	21:15:00	X KA 2845F JJ (KA 2845F JJ X)
30	Rantau Prapat (RAP)	21:35:00		

KA U55 (Sribilah Utama) Relasi RAP-MDN

No.	Stasiun dan Perhentian	Datang	Berangkat	Keterangan
1	Rantau Prapat (RAP)		22:30:00	
2	Marbau (MBU)	22:50:00	22:52:00	
3	Padang Halaban (PHA)	Ls	23:00:00	
4	Pamienke (PME)	Ls	23:11:00	
5	Situngir (SIU)	Ls	23:29:00	
6	Membang Muda (MBM)	23:40:00	23:42:00	
7	Aekloba (AKB)	Ls	23:52:00	
8	Puluraja (PUR)	Ls	23:57:00	
9	Teluk Dalam (TUK)	Ls	00:10:00	
10	Hengelo (HL)	Ls	00:14:00	
11	Kisaran (KIS)	00:28:00	00:38:00	
12	Bunut (BUU)	Ls	00:43:00	
13	Seibejangkar (SBJ)	Ls	00:57:00	
14	Dusun (DSU)	Ls	01:04:00	
15	Lima Puluh (LMP)	Ls	01:18:00	X KA U56 (KA U56 X)
16	Perlanaan (PRA)	01:26:00	01:28:00	// KA 2845F JJ (KA 2845F JJ =)
17	Bahlias (BLI)	Ls	01:34:00	
18	Bandar Tinggi (BDT)	Ls	01:46:00	X KA 2820 (KA 2820 X)
19	Laut Tador (LTD)	Ls	01:52:00	
20	Tebing Tinggi (TBI)	02:06:00	02:10:00	X KA 2822 (KA 2822 X)
21	Bamban (BMB)	Ls	02:22:00	X KA 2814 (KA 2814 X)
22	Rampah (RPH)	Ls	02:28:00	
23	Teluk Mengkudu (TKE)	Ls	02:35:00	// KA 2823 (KA 2823 =)
24	Lidah Tanah (LDT)	Ls	02:43:00	X KA 2802 (KA 2802 X)
25	Perbaungan (PBA)	Ls	02:50:00	
26	Lubuk Pakam (LBP)	02:59:00	03:03:00	X KA 2824 (KA 2824 X)
27	Araskabu (ARB)	03:11:00	03:13:00	(KA 2804 X)
28	Batang Kuis (BTK)	Ls	03:21:00	
29	Bandar Kalipah (BAP)	03:28:00	03:32:00	X KA 2816
30	Medan (MDN)	03:44:00		(KA U2 X)

KA U56 (Sribilah Utama) Relasi MDN-RAP

No.	Stasiun dan Perhentian	Datang	Berangkat	Keterangan
1	Medan (MDN)		22:50:00	X KA U57F JJ
2	Bandar Kalipah (BAP)	23:02:00	23:05:00	
3	Batang Kuis (BTK)	Ls	23:12:00	

No.	Stasiun dan Perhentian	Datang	Berangkat	Keterangan
4	Araskabu (ARB)	23:20:00	23:22:00	
5	Lubuk Pakam (LBP)	23:30:00	23:32:00	// KA 2820 (KA 2820 =)
6	Perbaungan (PBA)	Ls	23:40:00	
7	Lidah Tanah (LDT)	Ls	23:47:00	X KA 2819 (KA 2819 X)
8	Teluk Mengkudu (TKE)	Ls	23:55:00	X KA 2815 (KA 2815 X)
9	Rampah (RPH)	Ls	00:02:00	
10	Bamban (BMB)	Ls	00:08:00	
11	Tebing Tinggi (TBI)	00:20:00	00:24:00	X KA 2821 (KA 2821 X)
12	Laut Tador (LTD)	Ls	00:37:00	X KA 2823 (KA 2823 X)
13	Bandar Tinggi (BDT)	Ls	00:43:00	
14	Bahlias (BLI)	Ls	00:54:00	
15	Perlanaan (PRA)	01:00:00	01:02:00	X KA 2845F JJ (KA 2845F JJ X)
16	Lima Puluh (LMP)	01:12:00	01:20:00	X KA U55 (KA U55 X)
17	Dusun (DSU)	Ls	01:34:00	
18	Seibejangkar (SBJ)	Ls	01:41:00	
19	Bunut (BUU)	Ls	01:55:00	
20	Kisaran (KIS)	02:00:00	02:10:00	X KA 2831F JJ (KA 2831F JJ X)
21	Hengelo (HL)	Ls	02:24:00	
22	Teluk Dalam (TUK)	Ls	02:28:00	X KA 2835F JJ (KA 2835F JJ X)
23	Puluraja (PUR)	Ls	02:41:00	
24	Aekloba (AKB)	Ls	02:46:00	
25	Membang Muda (MBM)	02:56:00	02:58:00	
26	Situngir (SIU)	Ls	03:09:00	
27	Pamienke (PME)	Ls	03:27:00	
28	Padang Halaban (PHA)	Ls	03:39:00	
29	Marbau (MBU)	03:48:00	03:50:00	
30	Rantau Prapat (RAP)	04:10:00		

KA U57F (Sribilah Utama) Relasi RAP-MDN

No.	Stasiun dan Perhentian	Datang	Berangkat	Keterangan
1	Rantau Prapat (RAP)		17:05:00	
2	Marbau (MBU)	17:24:00	17:26:00	
3	Padang Halaban (PHA)	17:35:00	17:37:00	
4	Pamienke (PME)	Ls	17:49:00	
5	Situngir (SIU)	Ls	18:06:00	
6	Membang Muda (MBM)	18:17:00	18:19:00	
7	Aekloba (AKB)	Ls	18:29:00	
8	Puluraja (PUR)	18:36:00	18:38:00	
9	Teluk Dalam (TUK)	Ls	18:53:00	
10	Hengelo (HL)	Ls	18:57:00	
11	Kisaran (KIS)	19:11:00	19:19:00	X KA U54 (KA U54 X)
12	Bunut (BUU)	Ls	19:24:00	
13	Seibejangkar (SBJ)	Ls	19:37:00	

No.	Stasiun dan Perhentian	Datang	Berangkat	Keterangan
14	Dusun (DSU)	Ls	19:44:00	
15	Lima Puluh (LMP)	19:58:00	20:04:00	X KA U60F JJ (KA U60F JJ X)
16	Perlanaan (PRA)	20:13:00	20:15:00	
17	Bahlias (BLI)	Ls	20:21:00	
18	Bandar Tinggi (BDT)	Ls	20:32:00	(KA 2850F JJ X)
19	Laut Tador (LTD)	Ls	20:38:00	
20	Tebing Tinggi (TBI)	20:51:00	20:55:00	X KA U76 (KA U76 X)
21	Bamban (BMB)	Ls	21:08:00	
22	Rampah (RPH)	Ls	21:15:00	
23	Teluk Mengkudu (TKE)	Ls	21:23:00	
24	Lidah Tanah (LDT)	21:35:00	21:44:00	X KA U80F JJ (KA U80F JJ X)
25	Perbaungan (PBA)	Ls	21:52:00	
26	Lubuk Pakam (LBP)	22:01:00	22:03:00	
27	Araskabu (ARB)	22:12:00	22:14:00	
28	Batang Kuis (BTK)	Ls	22:22:00	
29	Bandar Kalipah (BAP)	22:28:00	22:30:00	
30	Medan (MDN)	22:43:00		(KA U56 X)

KA U58F (Sribilah Utama) Relasi MDN-RAP

No.	Stasiun dan Perhentian	Datang	Berangkat	Keterangan
1	Medan (MDN)		10:25:00	
2	Bandar Kalipah (BAP)	10:38:00	10:40:00	
3	Batang Kuis (BTK)	Ls	10:47:00	
4	Araskabu (ARB)	10:56:00	10:58:00	
5	Lubuk Pakam (LBP)	11:07:00	11:09:00	
6	Perbaungan (PBA)	Ls	11:18:00	
7	Lidah Tanah (LDT)	11:26:00	11:33:00	X KA U71 (KA U71 X)
8	Teluk Mengkudu (TKE)	Ls	11:43:00	
9	Rampah (RPH)	Ls	11:51:00	
10	Bamban (BMB)	12:00:00	12:06:00	X KA U51 (KA U51 X)
11	Tebing Tinggi (TBI)	12:20:00	12:24:00	(KA 2843 X) // KA 2818 (KA 2818 =)
12	Laut Tador (LTD)	Ls	12:37:00	
13	Bandar Tinggi (BDT)	Ls	12:43:00	
14	Bahlias (BLI)	Ls	12:54:00	
15	Perlanaan (PRA)	13:00:00	13:02:00	
16	Lima Puluh (LMP)	Ls	13:10:00	
17	Dusun (DSU)	Ls	13:23:00	
18	Seibejangkar (SBJ)	Ls	13:30:00	X KA U73 (KA U73 X)
19	Bunut (BUU)	Ls	13:44:00	
20	Kisaran (KIS)	13:49:00	13:59:00	
21	Hengelo (HL)	Ls	14:14:00	
22	Teluk Dalam (TUK)	Ls	14:19:00	

No.	Stasiun dan Perhentian	Datang	Berangkat	Keterangan
23	Puluraja (PUR)	14:35:00	14:37:00	(KA 2825 X)
24	Aekloba (AKB)	Ls	14:44:00	
25	Membang Muda (MBM)	14:55:00	14:57:00	
26	Situngir (SIU)	Ls	15:08:00	
27	Pamienke (PME)	15:27:00	15:33:00	X KA U53 (KA U53 X)
28	Padang Halaban (PHA)	15:46:00	15:48:00	
29	Marbau (MBU)	15:57:00	15:59:00	
30	Rantau Prapat (RAP)	16:18:00		

A.N. Direktur Operasi
OMR

IQBAL T ISKANDAR
NIPP. 44330

PT. KERETA API INDONESIA (Persero)
KANTOR PUSAT - BANDUNG

Toka: 12310, 12320, 12321, 12311 Fax: -

DAFTAR WAKTU

Berlaku pada Gapeka 2023

ISI:

1. KA U59F (Tanjung Balai Ekspres) Relasi TNB - MDN
KA U60F (Tanjung Balai Ekspres) Relasi MDN - TNB
2. BISNIS
3. Untuk keperluan angkutan penumpang
4. Puncak kecepatan lintas:

TNB - KIS = 80 Km/Jam

KIS - PRA = 70 Km/Jam

PRA - MDN = 80 Km/Jam

5. KA tersebut perjalanannya sesuai dengan GAPEKA.
6. EVP / VP, Manager Op, Manager Sarana Divre 1 Mdn, atur dinasan lok rangkaian dan awak KA-nya.
7. Memberhentikan luar biasa (BLB) suatu KA harus sesuai dengan PD 19 jilid 1 pasal 86.

KA U59F (Tanjung Balai Ekspres) Relasi TNB-MDN

No.	Stasiun dan Perhentian	Datang	Berangkat	Keterangan
1	Tanjung Balai (TNB)		07:00:00	X KA LU71-2
2	Kisaran (KIS)	07:22:00	07:32:00	
3	Bunut (BUU)	Ls	07:37:00	
4	Seibejangkar (SBJ)	Ls	07:51:00	X KA 2834F JJ (KA 2834F JJ X)
5	Dusun (DSU)	Ls	07:58:00	
6	Lima Puluh (LMP)	Ls	08:11:00	
7	Perlanaan (PRA)	08:19:00	08:21:00	X KA 2838F JJ (KA 2838F JJ X)
8	Bahliah (BLI)	Ls	08:27:00	
9	Bandar Tinggi (BDT)	Ls	08:40:00	
10	Laut Tador (LTD)	Ls	08:46:00	X KA 2852F JJ (KA 2852F JJ X)
11	Tebing Tinggi (TBI)	09:00:00	09:06:00	X KA U72 (KA U72 X)
12	Bamban (BMB)	Ls	09:21:00	
13	Rampah (RPH)	09:30:00	09:37:00	X KA U52 (KA U52 X)
14	Teluk Mengkudu (TKE)	Ls	09:47:00	
15	Lidah Tanah (LDT)	Ls	09:57:00	X KA 2846F JJ (KA 2846F JJ X)
16	Perbaungan (PBA)	Ls	10:06:00	
17	Lubuk Pakam (LBP)	10:16:00	10:20:00	X KA 2818 (KA 2818 X)
18	Araskabu (ARB)	10:30:00	10:32:00	
19	Batang Kuis (BTK)	Ls	10:42:00	
20	Bandar Kalipah (BAP)	10:50:00	10:53:00	X KA U58F JJ
21	Medan (MDN)	11:06:00		

KA U60F (Tanjung Balai Ekspres) Relasi MDN-TNB

No.	Stasiun dan Perhentian	Datang	Berangkat	Keterangan
1	Medan (MDN)		17:30:00	
2	Bandar Kalipah (BAP)	17:43:00	17:45:00	
3	Batang Kuis (BTK)	Ls	17:52:00	
4	Araskabu (ARB)	18:01:00	18:03:00	
5	Lubuk Pakam (LBP)	18:12:00	18:14:00	X KA 2803 (KA 2803 X)
6	Perbaungan (PBA)	Ls	18:23:00	
7	Lidah Tanah (LDT)	Ls	18:30:00	X KA 2841 (KA 2841 X)
8	Teluk Mengkudu (TKE)	Ls	18:39:00	
9	Rampah (RPH)	18:47:00	18:53:00	X KA U53 (KA U53 X)
10	Bamban (BMB)	Ls	19:00:00	
11	Tebing Tinggi (TBI)	19:13:00	19:16:00	X KA U69F JJ, 2851F JJ (KA 2851F JJ X)
12	Laut Tador (LTD)	Ls	19:29:00	X KA 2817 (KA 2817 X)
13	Bandar Tinggi (BDT)	Ls	19:35:00	
14	Bahliah (BLI)	Ls	19:46:00	
15	Perlanaan (PRA)	19:52:00	19:54:00	
16	Lima Puluh (LMP)	Ls	20:02:00	X KA U57F JJ (KA U57F JJ X)
17	Dusun (DSU)	Ls	20:16:00	
18	Seibejangkar (SBJ)	Ls	20:23:00	X KA U75 (KA U75 X)

No.	Stasiun dan Perhentian	Datang	Berangkat	Keterangan
19	Bunut (BUU)	Ls	20:36:00	
20	Kisaran (KIS)	20:41:00	20:51:00	(KA 2819 X)
21	Tanjung Balai (TNB)	21:13:00		(KA LU60F-3 JJ X)

A.N. Direktur Operasi
OMR



IQBAL T ISKANDAR
NIPP. 44330

PT. KERETA API INDONESIA (Persero)
KANTOR PUSAT - BANDUNG

Toka: 12310, 12320, 12321, 12311 Fax: -

DAFTAR WAKTU

Berlaku pada Gapeka 2023

ISI:

1. KA U61F (Amir Hamzah) Relasi BSG - BIJ
KA U62F (Amir Hamzah) Relasi BIJ - BSG
KA U63F (Amir Hamzah) Relasi BSG - BIJ
KA U64F (Amir Hamzah) Relasi BIJ - BSG
KA U65F (Amir Hamzah) Relasi BSG - BIJ
KA U66F (Amir Hamzah) Relasi BIJ - BSG

2. EKONOMI

3. Untuk keperluan angkutan penumpang

4. Puncak kecepatan lintas:

BSG - BIJ = 60 Km/Jam

5. KA tersebut perjalanannya sesuai dengan GAPEKA.

6. EVP / VP, Manager Op, Manager Sarana Divre 1 Mdn, atur dinas lok rangkaian dan awak KA-nya.

7. Memberhentikan luar biasa (BLB) suatu KA harus sesuai dengan PD 19 jilid 1 pasal 86.

KA U61F (Amir Hamzah) Relasi BSG-BIJ

No.	Stasiun dan Perhentian	Datang	Berangkat	Keterangan
1	Besitang (BSG)		08:30:00	X KA U62F JJ
2	Pangkalan Brandan (PBD)	08:48:00	09:08:00	
3	Gebang (GBA)	09:24:00	09:26:00	
4	Tanjung Pura (TPU)	09:40:00	09:42:00	
5	Tanjung Selamat (TAS)	10:02:00	10:04:00	
6	Stabat (SBT)	10:20:00	10:22:00	
7	Kuala Bingei (KBG)	10:36:00	10:38:00	
8	Binjai (BIJ)	10:58:00		(KA U64F JJ X)

KA U62F (Amir Hamzah) Relasi BIJ-BSG

No.	Stasiun dan Perhentian	Datang	Berangkat	Keterangan
1	Binjai (BIJ)		05:30:00	
2	Kuala Bingei (KBG)	05:50:00	05:52:00	
3	Stabat (SBT)	06:06:00	06:08:00	
4	Tanjung Selamat (TAS)	06:24:00	06:26:00	
5	Tanjung Pura (TPU)	06:46:00	06:48:00	
6	Gebang (GBA)	07:02:00	07:04:00	
7	Pangkalan Brandan (PBD)	07:20:00	07:40:00	
8	Besitang (BSG)	07:58:00		(KA U61F JJ X)

KA U63F (Amir Hamzah) Relasi BSG-BIJ

No.	Stasiun dan Perhentian	Datang	Berangkat	Keterangan
1	Besitang (BSG)		14:25:00	X KA U64F JJ
2	Pangkalan Brandan (PBD)	14:43:00	15:03:00	
3	Gebang (GBA)	15:19:00	15:21:00	
4	Tanjung Pura (TPU)	15:35:00	15:37:00	
5	Tanjung Selamat (TAS)	15:57:00	15:59:00	
6	Stabat (SBT)	16:15:00	16:17:00	
7	Kuala Bingei (KBG)	16:31:00	16:33:00	
8	Binjai (BIJ)	16:53:00		(KA U66F JJ X)

KA U64F (Amir Hamzah) Relasi BIJ-BSG

No.	Stasiun dan Perhentian	Datang	Berangkat	Keterangan
1	Binjai (BIJ)		11:30:00	(KA U61F JJ X)
2	Kuala Bingei (KBG)	11:50:00	11:52:00	
3	Stabat (SBT)	12:06:00	12:08:00	
4	Tanjung Selamat (TAS)	12:24:00	12:26:00	
5	Tanjung Pura (TPU)	12:46:00	12:48:00	
6	Gebang (GBA)	13:02:00	13:04:00	
7	Pangkalan Brandan (PBD)	13:20:00	13:40:00	
8	Besitang (BSG)	13:58:00		(KA U63F JJ X)

KA U65F (Amir Hamzah) Relasi BSG-BIJ

No.	Stasiun dan Perhentian	Datang	Berangkat	Keterangan
1	Besitang (BSG)		20:20:00	X KA U66F JJ
2	Pangkalan Brandan (PBD)	20:38:00	20:58:00	
3	Gebang (GBA)	21:14:00	21:16:00	
4	Tanjung Pura (TPU)	21:30:00	21:32:00	
5	Tanjung Selamat (TAS)	21:52:00	21:54:00	
6	Stabat (SBT)	22:10:00	22:12:00	
7	Kuala Bingei (KBG)	22:26:00	22:28:00	
8	Binjai (BIJ)	22:48:00		

KA U66F (Amir Hamzah) Relasi BIJ-BSG

No.	Stasiun dan Perhentian	Datang	Berangkat	Keterangan
1	Binjai (BIJ)		17:20:00	X KA U63F JJ
2	Kuala Bingei (KBG)	17:40:00	17:42:00	
3	Stabat (SBT)	17:56:00	17:58:00	
4	Tanjung Selamat (TAS)	18:14:00	18:16:00	
5	Tanjung Pura (TPU)	18:36:00	18:38:00	
6	Gebang (GBA)	18:52:00	18:54:00	
7	Pangkalan Brandan (PBD)	19:10:00	19:30:00	
8	Besitang (BSG)	19:48:00		(KA U65F JJ X)

A.N. Direktur Operasi
OMR



IQBAL T ISKANDAR
NIPP. 44330

PT. KERETA API INDONESIA (Persero)
KANTOR PUSAT - BANDUNG

Toka: 12310, 12320, 12321, 12311 Fax: -

DAFTAR WAKTU

Berlaku mulai pada Gapeka 2023

ISI:

1. KA U67F (Datuk Belambangan) Relasi KTJ - TBI
KA U68F (Datuk Belambangan) Relasi TBI - KTJ
KA U69F (Datuk Belambangan) Relasi KTJ - TBI
KA U70F (Datuk Belambangan) Relasi TBI - KTJ
2. EKONOMI
3. Untuk keperluan angkutan penumpang
4. Puncak kecepatan lintas:

LAG - BDT = 40 Km/Jam
BDT - TBI = 60 Km/Jam
5. KA tersebut perjalanannya sesuai dengan GAPEKA.
6. EVP / VP, Manager Op, Manager Sarana Divre 1 Mdn, atur dinasan lok rangkaian dan awak KA-nya.
7. Memberhentikan luar biasa (BLB) suatu KA harus sesuai dengan PD 19 jilid 1 pasal 86.

KA U67F (Datuk Belambangan) Relasi LAG-TBI

No.	Stasiun dan Perhentian	Datang	Berangkat	Keterangan
1	Lalang (LAG)		08:25:00	
2	Tanjung Gading (TGD)	08:49:00	08:51:00	
3	Bandar Tinggi (BDT)	09:05:00	09:09:00	X KA 2852F JJ (KA 2852F JJ X)
4	Laut Tador (LTD)	09:18:00	09:25:00	X KA U72 (KA U72 X)
5	Tebing Tinggi (TBI)	09:40:00		(KA U52 X)

KA U68F (Datuk Belambangan) Relasi TBI-LAG

No.	Stasiun dan Perhentian	Datang	Berangkat	Keterangan
1	Tebing Tinggi (TBI)		06:20:00	
2	Laut Tador (LTD)	Ls	06:34:00	
3	Bandar Tinggi (BDT)	06:41:00	06:44:00	
4	Tanjung Gading (TGD)	06:59:00	07:01:00	X KA 2837F JJ (KA 2837F JJ X)
5	Lalang (LAG)	07:25:00		

KA U69F (Datuk Belambangan) Relasi LAG-TBI

No.	Stasiun dan Perhentian	Datang	Berangkat	Keterangan
1	Lalang (LAG)		18:00:00	
2	Tanjung Gading (TGD)	18:24:00	18:26:00	
3	Bandar Tinggi (BDT)	18:41:00	18:44:00	
4	Laut Tador (LTD)	Ls	18:51:00	
5	Tebing Tinggi (TBI)	19:05:00		(KA U60F JJ X)

KA U70F (Datuk Belambangan) Relasi TBI-LAG

No.	Stasiun dan Perhentian	Datang	Berangkat	Keterangan
1	Tebing Tinggi (TBI)		15:30:00	
2	Laut Tador (LTD)	Ls	15:44:00	
3	Bandar Tinggi (BDT)	15:51:00	15:54:00	
4	Tanjung Gading (TGD)	16:09:00	16:11:00	
5	Lalang (LAG)	16:35:00		

A.N. Direktur Operasi
OMR

IQBAL T ISKANDAR
NIPP. 44330

PT. KERETA API INDONESIA (Persero)
KANTOR PUSAT - BANDUNG

Toka: 12310, 12320, 12321, 12311 Fax: -

DAFTAR WAKTU

Berlaku pada Gapeka 2023

ISI:

1. KA U101F (Belawan Indah) Relasi MDN - BLW
KA U102F (Belawan Indah) Relasi BLW - MDN
KA U103F (Belawan Indah) Relasi MDN - BLW
KA U104F (Belawan Indah) Relasi BLW - MDN
2. EKONOMI
3. Untuk keperluan angkutan penumpang
4. Puncak kecepatan lintas:

MDN - LBU = 70 Km/Jam
LBU - BLW = 45 Km/Jam
5. KA tersebut perjalanannya sesuai dengan GAPEKA.
6. EVP / VP, Manager Op, Manager Sarana Divre 1 Mdn, atur dinasan lok rangkaian dan awak KA-nya.
7. Memberhentikan luar biasa (BLB) suatu KA harus sesuai dengan PD 19 jilid 1 pasal 86.

KA U101F (Belawan Indah) Relasi MDN-BLW

No.	Stasiun dan Perhentian	Datang	Berangkat	Keterangan
1	Medan (MDN)		04:50:00	X KA RU72, LU55-2, 2844
2	Pulu Brayan (PUB)	04:58:00	05:00:00	X KA 2852F JJ (KA 2852F JJ X)
3	Titi Papan (TPP)	Ls	-	
4	Labuan (LBU)	05:15:00	05:17:00	
5	Belawan (BLW)	05:28:00		(KA 2812, U102F JJ X)

KA U102F (Belawan Indah) Relasi BLW-MDN

No.	Stasiun dan Perhentian	Datang	Berangkat	Keterangan
1	Belawan (BLW)		06:03:00	X KA U101F JJ, 2823
2	Labuan (LBU)	06:14:00	06:20:00	X KA 2845F JJ (KA 2845F JJ X)
3	Titi Papan (TPP)	Ls	-	
4	Pulu Brayan (PUB)	06:35:00	06:37:00	
5	Medan (MDN)	06:45:00		(KA LU52-1 X)

KA U103F (Belawan Indah) Relasi MDN-BLW

No.	Stasiun dan Perhentian	Datang	Berangkat	Keterangan
1	Medan (MDN)		18:30:00	X KA RU76
2	Pulu Brayan (PUB)	18:38:00	18:40:00	(KA R3904 X)
3	Titi Papan (TPP)	Ls	-	
4	Labuan (LBU)	18:55:00	18:57:00	
5	Belawan (BLW)	19:08:00		(KA U104F JJ X)

KA U104F (Belawan Indah) Relasi BLW-MDN

No.	Stasiun dan Perhentian	Datang	Berangkat	Keterangan
1	Belawan (BLW)		19:30:00	X KA U103F JJ
2	Labuan (LBU)	19:41:00	19:43:00	X KA L2820-1 (KA L2820-1 X)
3	Titi Papan (TPP)	Ls	-	
4	Pulu Brayan (PUB)	19:58:00	20:00:00	X KA 2803 (KA 2803 X)
5	Medan (MDN)	20:08:00		(KA 2841 X)

A.N. Direktur Operasi
OMR

IQBAL T ISKANDAR
NIPP. 44330

PT. KERETA API INDONESIA (Persero)
KANTOR PUSAT - BANDUNG

Toka: 12310, 12320, 12321, 12311 Fax: -

DAFTAR WAKTU

Berlaku pada Gapeka 2023

ISI:

1. KA U71 (Putri Deli) Relasi TNB - MDN
KA U72 (Putri Deli) Relasi MDN - TNB
KA U73 (Putri Deli) Relasi TNB - MDN
KA U74 (Putri Deli) Relasi MDN - TNB
KA U75 (Putri Deli) Relasi TNB - MDN
KA U76 (Putri Deli) Relasi MDN - TNB

2. EKONOMI

3. Untuk keperluan angkutan penumpang

4. Puncak kecepatan lintas:

TNB - KIS = 80 Km/Jam

KIS - PRA = 70 Km/Jam

PRA - MDN = 80 Km/Jam

5. KA tersebut perjalanannya sesuai dengan GAPEKA.
6. EVP / VP, Manager Op, Manager Sarana Divre 1 Mdn, atur dinasan lok rangkaian dan awak KA-nya.
7. Memberhentikan luar biasa (BLB) suatu KA harus sesuai dengan PD 19 jilid 1 pasal 86.

KA U71 (Putri Deli) Relasi TNB-MDN

No.	Stasiun dan Perhentian	Datang	Berangkat	Keterangan
1	Tanjung Balai (TNB)		08:20:00	
2	Kisaran (KIS)	08:42:00	08:52:00	X KA 2834F JJ
3	Bunut (BUU)	Ls	08:57:00	
4	Seibejangkar (SBJ)	09:11:00	09:15:00	X KA 2838F JJ (KA 2838F JJ X)
5	Dusun (DSU)	Ls	09:23:00	
6	Lima Puluh (LMP)	09:37:00	09:39:00	
7	Perlanaan (PRA)	09:48:00	09:54:00	X KA U72 (KA U72 X)
8	Bahliah (BLI)	Ls	10:00:00	
9	Bandar Tinggi (BDT)	10:13:00	10:20:00	X KA U52 (KA U52 X)
10	Laut Tador (LTD)	Ls	10:28:00	
11	Tebing Tinggi (TBI)	10:42:00	10:46:00	X KA 2846F JJ (KA 2846F JJ X)
12	Bamban (BMB)	Ls	11:00:00	
13	Rampah (RPH)	11:08:00	11:12:00	X KA 2818 (KA 2818 X)
14	Teluk Mengkudu (TKE)	Ls	11:21:00	
15	Lidah Tanah (LDT)	Ls	11:31:00	X KA U58F JJ (KA U58F JJ X)
16	Perbaungan (PBA)	11:40:00	11:42:00	
17	Lubuk Pakam (LBP)	11:52:00	11:54:00	
18	Araskabu (ARB)	12:03:00	12:05:00	
19	Batang Kuis (BTK)	12:15:00	12:17:00	
20	Bandar Kalipah (BAP)	12:26:00	12:28:00	
21	Medan (MDN)	12:41:00		(KA U74 X)

KA U72 (Putri Deli) Relasi MDN-TNB

No.	Stasiun dan Perhentian	Datang	Berangkat	Keterangan
1	Medan (MDN)		07:10:00	
2	Bandar Kalipah (BAP)	07:23:00	07:25:00	
3	Batang Kuis (BTK)	07:33:00	07:35:00	
4	Araskabu (ARB)	07:45:00	07:47:00	
5	Lubuk Pakam (LBP)	07:57:00	07:59:00	
6	Perbaungan (PBA)	08:10:00	08:12:00	
7	Lidah Tanah (LDT)	Ls	08:22:00	X KA U77 (KA U77 X)
8	Teluk Mengkudu (TKE)	Ls	08:32:00	
9	Rampah (RPH)	08:41:00	08:43:00	
10	Bamban (BMB)	Ls	08:51:00	
11	Tebing Tinggi (TBI)	09:04:00	09:09:00	X KA U59F JJ (KA U59F JJ X)
12	Laut Tador (LTD)	Ls	09:23:00	X KA U67F JJ (KA U67F JJ X)
13	Bandar Tinggi (BDT)	09:31:00	09:33:00	
14	Bahliah (BLI)	Ls	09:46:00	
15	Perlanaan (PRA)	09:52:00	09:56:00	X KA U71 (KA U71 X)
16	Lima Puluh (LMP)	10:05:00	10:07:00	
17	Dusun (DSU)	Ls	10:22:00	
18	Seibejangkar (SBJ)	10:31:00	10:39:00	X KA U51 (KA U51 X)

No.	Stasiun dan Perhentian	Datang	Berangkat	Keterangan
19	Bunut (BUU)	Ls	10:53:00	
20	Kisaran (KIS)	10:58:00	11:08:00	
21	Tanjung Balai (TNB)	11:30:00		

KA U73 (Putri Deli) Relasi TNB-MDN

No.	Stasiun dan Perhentian	Datang	Berangkat	Keterangan
1	Tanjung Balai (TNB)		12:30:00	
2	Kisaran (KIS)	12:52:00	13:02:00	X KA 2846F JJ
3	Bunut (BUU)	Ls	13:07:00	
4	Seibejangkar (SBJ)	13:24:00	13:32:00	X KA U58F JJ (KA U58F JJ X)
5	Dusun (DSU)	Ls	13:40:00	
6	Lima Puluh (LMP)	13:54:00	13:58:00	X KA 2818 (KA 2818 X)
7	Perlanaan (PRA)	14:07:00	14:09:00	
8	Bahlias (BLI)	Ls	14:15:00	
9	Bandar Tinggi (BDT)	14:27:00	14:29:00	
10	Laut Tador (LTD)	Ls	14:36:00	
11	Tebing Tinggi (TBI)	14:50:00	14:54:00	X KA U74 (KA U74 X)
12	Bamban (BMB)	Ls	15:07:00	
13	Rampah (RPH)	15:15:00	15:17:00	
14	Teluk Mengkudu (TKE)	Ls	15:25:00	
15	Lidah Tanah (LDT)	Ls	15:34:00	
16	Perbaungan (PBA)	15:43:00	15:45:00	
17	Lubuk Pakam (LBP)	15:55:00	15:57:00	
18	Araskabu (ARB)	16:06:00	16:08:00	
19	Batang Kuis (BTK)	16:18:00	16:20:00	
20	Bandar Kalipah (BAP)	16:28:00	16:30:00	X KA U54
21	Medan (MDN)	16:43:00		

KA U74 (Putri Deli) Relasi MDN-TNB

No.	Stasiun dan Perhentian	Datang	Berangkat	Keterangan
1	Medan (MDN)		12:50:00	X KA U71
2	Bandar Kalipah (BAP)	13:03:00	13:06:00	
3	Batang Kuis (BTK)	13:15:00	13:17:00	
4	Araskabu (ARB)	13:27:00	13:29:00	
5	Lubuk Pakam (LBP)	13:38:00	13:42:00	X KA 2843 (KA 2843 X)
6	Perbaungan (PBA)	13:52:00	13:54:00	(KA 2811 X)
7	Lidah Tanah (LDT)	Ls	14:03:00	
8	Teluk Mengkudu (TKE)	Ls	14:13:00	
9	Rampah (RPH)	14:21:00	14:25:00	X KA 2801 (KA 2801 X)
10	Bamban (BMB)	Ls	14:33:00	
11	Tebing Tinggi (TBI)	14:46:00	14:52:00	X KA U73 (KA U73 X)
12	Laut Tador (LTD)	Ls	15:06:00	
13	Bandar Tinggi (BDT)	15:13:00	15:15:00	

No.	Stasiun dan Perhentian	Datang	Berangkat	Keterangan
14	Bahlias (BLI)	Ls	15:28:00	
15	Perlanaan (PRA)	15:34:00	15:36:00	
16	Lima Puluh (LMP)	15:45:00	15:49:00	X KA 2803 (KA 2803 X)
17	Dusun (DSU)	Ls	16:03:00	
18	Seibejangkar (SBJ)	16:11:00	16:13:00	X KA 2827
19	Bunut (BUU)	Ls	16:27:00	
20	Kisaran (KIS)	16:32:00	16:42:00	
21	Tanjung Balai (TNB)	17:04:00		

KA U75 (Putri Deli) Relasi TNB-MDN

No.	Stasiun dan Perhentian	Datang	Berangkat	Keterangan
1	Tanjung Balai (TNB)		19:25:00	
2	Kisaran (KIS)	19:47:00	19:57:00	
3	Bunut (BUU)	Ls	20:02:00	
4	Seibejangkar (SBJ)	20:19:00	20:25:00	X KA U60F JJ (KA U60F JJ X)
5	Dusun (DSU)	Ls	20:33:00	
6	Lima Puluh (LMP)	20:47:00	20:49:00	
7	Perlanaan (PRA)	20:58:00	21:00:00	X KA 2850F JJ
8	Bahlias (BLI)	Ls	21:06:00	
9	Bandar Tinggi (BDT)	21:18:00	21:22:00	X KA U76 (KA U76 X)
10	Laut Tador (LTD)	Ls	21:29:00	
11	Tebing Tinggi (TBI)	21:43:00	21:47:00	
12	Bamban (BMB)	22:02:00	22:09:00	X KA U80F JJ (KA U80F JJ X)
13	Rampah (RPH)	Ls	22:17:00	
14	Teluk Mengkudu (TKE)	Ls	22:25:00	
15	Lidah Tanah (LDT)	Ls	22:35:00	
16	Perbaungan (PBA)	22:43:00	22:45:00	
17	Lubuk Pakam (LBP)	22:55:00	22:57:00	X KA 2820 (KA 2820 X)
18	Araskabu (ARB)	23:06:00	23:08:00	
19	Batang Kuis (BTK)	23:18:00	23:20:00	
20	Bandar Kalipah (BAP)	23:28:00	23:30:00	// KA 2813 (KA 2813 =)
21	Medan (MDN)	23:43:00		(KA 2822 X)

KA U76 (Putri Deli) Relasi MDN-TNB

No.	Stasiun dan Perhentian	Datang	Berangkat	Keterangan
1	Medan (MDN)		18:50:00	X KA U79F JJ
2	Bandar Kalipah (BAP)	19:03:00	19:05:00	(KA 2803 X)
3	Batang Kuis (BTK)	19:13:00	19:15:00	
4	Araskabu (ARB)	19:24:00	19:26:00	
5	Lubuk Pakam (LBP)	19:35:00	19:39:00	X KA U53 (KA U53 X)
6	Perbaungan (PBA)	19:49:00	19:51:00	
7	Lidah Tanah (LDT)	Ls	19:59:00	
8	Teluk Mengkudu (TKE)	Ls	20:09:00	X KA 2851F JJ (KA 2851F JJ X)

No.	Stasiun dan Perhentian	Datang	Berangkat	Keterangan
9	Rampah (RPH)	Ls	20:16:00	
10	Bamban (BMB)	Ls	20:23:00	X KA 2817 (KA 2817 X)
11	Tebing Tinggi (TBI)	20:37:00	20:53:00	X KA U57F JJ (KA U57F JJ X)
12	Laut Tador (LTD)	Ls	21:07:00	
13	Bandar Tinggi (BDT)	21:14:00	21:20:00	X KA U75 (KA U75 X)
14	Bahlias (BLI)	Ls	21:33:00	
15	Perlanaan (PRA)	21:39:00	21:43:00	X KA 2819 (KA 2819 X)
16	Lima Puluh (LMP)	21:52:00	21:54:00	
17	Dusun (DSU)	Ls	22:07:00	
18	Seibejangkar (SBJ)	22:15:00	22:19:00	X KA 2821 (KA 2821 X)
19	Bunut (BUU)	Ls	22:33:00	
20	Kisaran (KIS)	22:38:00	22:48:00	(KA 2823 X)
21	Tanjung Balai (TNB)	23:10:00		

A.N. Direktur Operasi
OMR

IQBAL T ISKANDAR
NIPP. 44330

PT. KERETA API INDONESIA (Persero)
KANTOR PUSAT - BANDUNG

Toka: 12310, 12320, 12321, 12311 Fax: -

DAFTAR WAKTU

Berlaku pada Gapeka 2023

ISI:

1. KA U77 (Siantar Ekspres) Relasi SIR - MDN
KA U78 (Siantar Ekspres) Relasi MDN - SIR
KA U79 (Siantar Ekspres) Relasi SIR - MDN
KA U80 (Siantar Ekspres) Relasi MDN - SIR

2. EKONOMI

3. Untuk keperluan angkutan penumpang

4. Puncak kecepatan lintas:

SIR - MDN = 90 Km/Jam

5. KA tersebut perjalanannya sesuai dengan GAPEKA.

6. EVP / VP, Manager Op, Manager Sarana Divre 1 Mdn, atur dinasan lok rangkaian dan awak KA-nya.

7. Memberhentikan luar biasa (BLB) suatu KA harus sesuai dengan PD 19 jilid 1 pasal 86.

KA U77 (Siantar Ekspres) Relasi SIR-MDN

No.	Stasiun dan Perhentian	Datang	Berangkat	Keterangan
1	Siantar (SIR)		06:40:00	
2	Dolok Merangir (DMR)	07:01:00	07:03:00	X KA 2830, (KA R2802 X)
3	Baja Linggei (BJL)	07:11:00	07:13:00	
4	Tebing Tinggi (TBI)	07:34:00	07:38:00	X KA 2844 (KA 2844 X)
5	Bamban (BMB)	Ls	07:50:00	X KA 2852F JJ (KA 2852F JJ X)
6	Rampah (RPH)	07:57:00	07:59:00	
7	Teluk Mengkudu (TKE)	Ls	08:07:00	
8	Lidah Tanah (LDT)	08:17:00	08:24:00	X KA U72 (KA U72 X)
9	Perbaungan (PBA)	08:35:00	08:38:00	
10	Lubuk Pakam (LBP)	08:50:00	08:57:00	X KA U52, 2846F JJ (KA U52, 2846F JJ X)
11	Araskabu (ARB)	09:06:00	09:08:00	
12	Batang Kuis (BTK)	09:18:00	09:20:00	
13	Bandar Kalipah (BAP)	09:28:00	09:30:00	X KA 2818
14	Medan (MDN)	09:42:00		

KA U78 (Siantar Ekspres) Relasi MDN-SIR

No.	Stasiun dan Perhentian	Datang	Berangkat	Keterangan
1	Medan (MDN)		12:05:00	
2	Bandar Kalipah (BAP)	12:17:00	12:19:00	(KA U71 X)
3	Batang Kuis (BTK)	12:27:00	12:29:00	
4	Araskabu (ARB)	12:38:00	12:40:00	
5	Lubuk Pakam (LBP)	12:48:00	12:52:00	X KA U51 (KA U51 X)
6	Perbaungan (PBA)	13:02:00	13:04:00	
7	Lidah Tanah (LDT)	Ls	13:12:00	X KA 2843 (KA 2843 X)
8	Teluk Mengkudu (TKE)	Ls	13:20:00	
9	Rampah (RPH)	13:28:00	13:30:00	
10	Bamban (BMB)	Ls	13:38:00	
11	Tebing Tinggi (TBI)	13:50:00	13:54:00	X KA 2801 (KA 2801 X)
12	Baja Linggei (BJL)	14:15:00	14:17:00	
13	Dolok Merangir (DMR)	14:25:00	14:27:00	
14	Siantar (SIR)	14:48:00		(KA U79F JJ X)

KA U79F (Siantar Ekspres) Relasi SIR-MDN

No.	Stasiun dan Perhentian	Datang	Berangkat	Keterangan
1	Siantar (SIR)		15:20:00	X KA U78
2	Dolok Merangir (DMR)	15:41:00	15:43:00	
3	Baja Linggei (BJL)	15:51:00	15:53:00	
4	Tebing Tinggi (TBI)	16:14:00	16:18:00	
5	Bamban (BMB)	Ls	16:31:00	
6	Rampah (RPH)	16:38:00	16:40:00	
7	Teluk Mengkudu (TKE)	Ls	16:49:00	

No.	Stasiun dan Perhentian	Datang	Berangkat	Keterangan
8	Lidah Tanah (LDT)	17:00:00	17:09:00	X KA U54 (KA U54 X)
9	Perbaungan (PBA)	17:20:00	17:22:00	
10	Lubuk Pakam (LBP)	17:34:00	17:37:00	
11	Araskabu (ARB)	17:46:00	17:49:00	
12	Batang Kuis (BTK)	17:58:00	18:00:00	
13	Bandar Kalipah (BAP)	18:08:00	18:10:00	
14	Medan (MDN)	18:22:00		(KA U76 X)

KA U80F (Siantar Ekspres) Relasi MDN-SIR

No.	Stasiun dan Perhentian	Datang	Berangkat	Keterangan
1	Medan (MDN)		20:35:00	X KA U53
2	Bandar Kalipah (BAP)	20:47:00	20:50:00	
3	Batang Kuis (BTK)	20:58:00	21:00:00	
4	Araskabu (ARB)	21:09:00	21:11:00	X KA 2851F JJ
5	Lubuk Pakam (LBP)	21:20:00	21:22:00	X KA 2817 (KA 2817 X)
6	Perbaungan (PBA)	21:32:00	21:34:00	
7	Lidah Tanah (LDT)	Ls	21:42:00	X KA U57F JJ (KA U57F JJ X)
8	Teluk Mengkudu (TKE)	Ls	21:50:00	X KA 2813 (KA 2813 X)
9	Rampah (RPH)	21:58:00	22:00:00	
10	Bamban (BMB)	Ls	22:07:00	X KA U75 (KA U75 X)
11	Tebing Tinggi (TBI)	22:19:00	22:23:00	
12	Baja Linggei (BJL)	22:44:00	22:46:00	
13	Dolok Merangir (DMR)	22:54:00	22:56:00	
14	Siantar (SIR)	23:17:00		(KA LU80-1 X)

KA U81 (Sri Lelawangsa) Relasi BIJ-MDN

No.	Stasiun dan Perhentian	Datang	Berangkat	Keterangan
1	Binjai (BIJ)		04:50:00	X KA U82
2	Medan (MDN)	05:12:00		(KA U84 X)

A.N. Direktur Operasi
OMR

IQBAL T ISKANDAR
NIPP. 44330

PT. KERETA API INDONESIA (Persero)
KANTOR PUSAT - BANDUNG

Toka: 12310, 12320, 12321, 12311 Fax: -

DAFTAR WAKTU

Berlaku pada Gapeka 2023

ISI:

1. KA U81 (Sri Lelawangsa) Relasi BIJ - MDN
KA U82 (Sri Lelawangsa) Relasi MDN - BIJ
KA U83 (Sri Lelawangsa) Relasi KBG - MDN
KA U84 (Sri Lelawangsa) Relasi MDN - KBG
KA U85 (Sri Lelawangsa) Relasi BIJ - MDN
KA U86 (Sri Lelawangsa) Relasi MDN - BIJ
KA U87 (Sri Lelawangsa) Relasi BIJ - MDN
KA U88 (Sri Lelawangsa) Relasi MDN - BIJ
KA U89 (Sri Lelawangsa) Relasi BIJ - MDN
KA U90 (Sri Lelawangsa) Relasi MDN - BIJ
KA U91 (Sri Lelawangsa) Relasi BIJ - MDN
KA U92 (Sri Lelawangsa) Relasi MDN - BIJ
KA U93 (Sri Lelawangsa) Relasi BIJ - MDN
KA U94 (Sri Lelawangsa) Relasi MDN - BIJ
KA U95 (Sri Lelawangsa) Relasi KBG - MDN
KA U96 (Sri Lelawangsa) Relasi MDN - KBG
KA U97 (Sri Lelawangsa) Relasi BIJ - MDN
KA U98 (Sri Lelawangsa) Relasi MDN - BIJ
KA U99 (Sri Lelawangsa) Relasi BIJ - MDN
KA U100 (Sri Lelawangsa) Relasi MDN - BIJ

2. EKONOMI

3. Untuk keperluan angkutan penumpang

4. Puncak kecepatan lintas:

MDN - BIJ = 80 Km/Jam

KBG - MDN = 80 Km/Jam

5. KA tersebut perjalanannya sesuai dengan GAPEKA.

6. EVP / VP, Manager Op, Manager Sarana Divre 1 Mdn, atur dinasan lok rangkaian dan awak KA-nya.

7. Memberhentikan luar biasa (BLB) suatu KA harus sesuai dengan PD 19 jilid 1 pasal 86.

KA U82 (Sri Lelawangsa) Relasi MDN-BIJ

No.	Stasiun dan Perhentian	Datang	Berangkat	Keterangan
1	Medan (MDN)		04:05:00	
2	Binjai (BIJ)	04:27:00		(KA U81 X)

KA U83 (Sri Lelawangsa) Relasi KBG-MDN

No.	Stasiun dan Perhentian	Datang	Berangkat	Keterangan
1	Kuala Bingei (KBG)		06:45:00	X KA U84
2	Binjai (BIJ)	07:01:00	07:10:00	
3	Medan (MDN)	07:32:00		(KA U86 X)

KA U84 (Sri Lelawangsa) Relasi MDN-KBG

No.	Stasiun dan Perhentian	Datang	Berangkat	Keterangan
1	Medan (MDN)		05:35:00	X KA U81
2	Binjai (BIJ)	05:57:00	06:02:00	
3	Kuala Bingei (KBG)	06:18:00		(KA U83 X)

KA U85 (Sri Lelawangsa) Relasi BIJ-MDN

No.	Stasiun dan Perhentian	Datang	Berangkat	Keterangan
1	Binjai (BIJ)		08:45:00	X KA U86
2	Medan (MDN)	09:07:00		(KA U88 X)

KA U86 (Sri Lelawangsa) Relasi MDN-BIJ

No.	Stasiun dan Perhentian	Datang	Berangkat	Keterangan
1	Medan (MDN)		08:00:00	X KA U83
2	Binjai (BIJ)	08:22:00		(KA U85 X)

KA U87 (Sri Lelawangsa) Relasi BIJ-MDN

No.	Stasiun dan Perhentian	Datang	Berangkat	Keterangan
1	Binjai (BIJ)		10:15:00	X KA U88
2	Medan (MDN)	10:37:00		(KA U90 X)

KA U88 (Sri Lelawangsa) Relasi MDN-BIJ

No.	Stasiun dan Perhentian	Datang	Berangkat	Keterangan
1	Medan (MDN)		09:30:00	X KA U85
2	Binjai (BIJ)	09:52:00		(KA U87 X)

KA U89 (Sri Lelawangsa) Relasi BIJ-MDN

No.	Stasiun dan Perhentian	Datang	Berangkat	Keterangan
1	Binjai (BIJ)		11:50:00	X KA U90
2	Medan (MDN)	12:12:00		

KA U90 (Sri Lelawangsa) Relasi MDN-BIJ

No.	Stasiun dan Perhentian	Datang	Berangkat	Keterangan
1	Medan (MDN)		11:00:00	X KA U87
2	Binjai (BIJ)	11:22:00		(KA U89 X)

KA U91 (Sri Lelawangsa) Relasi BIJ-MDN

No.	Stasiun dan Perhentian	Datang	Berangkat	Keterangan
1	Binjai (BIJ)		14:45:00	X KA U92
2	Medan (MDN)	15:07:00		(KA U94 X)

KA U92 (Sri Lelawangsa) Relasi MDN-BIJ

No.	Stasiun dan Perhentian	Datang	Berangkat	Keterangan
1	Medan (MDN)		14:00:00	
2	Binjai (BIJ)	14:22:00		(KA U91 X)

KA U93 (Sri Lelawangsa) Relasi BIJ-MDN

No.	Stasiun dan Perhentian	Datang	Berangkat	Keterangan
1	Binjai (BIJ)		16:30:00	X KA U94
2	Medan (MDN)	16:52:00		(KA U96 X)

KA U94 (Sri Lelawangsa) Relasi MDN-BIJ

No.	Stasiun dan Perhentian	Datang	Berangkat	Keterangan
1	Medan (MDN)		15:30:00	X KA U91
2	Binjai (BIJ)	15:52:00		(KA U93 X)

KA U95 (Sri Lelawangsa) Relasi KBG-MDN

No.	Stasiun dan Perhentian	Datang	Berangkat	Keterangan
1	Kuala Bingei (KBG)		18:25:00	X KA U96
2	Binjai (BIJ)	18:41:00	18:47:00	
3	Medan (MDN)	19:09:00		(KA U98 X)

KA U96 (Sri Lelawangsa) Relasi MDN-KBG

No.	Stasiun dan Perhentian	Datang	Berangkat	Keterangan
1	Medan (MDN)		17:15:00	X KA U93
2	Binjai (BIJ)	17:37:00	17:43:00	
3	Kuala Bingei (KBG)	17:59:00		(KA U95 X)

KA U97 (Sri Lelawangsa) Relasi BIJ-MDN

No.	Stasiun dan Perhentian	Datang	Berangkat	Keterangan
1	Binjai (BIJ)		20:30:00	X KA U98
2	Medan (MDN)	20:52:00		(KA U100 X)

KA U98 (Sri Lelawangsa) Relasi MDN-BIJ

No.	Stasiun dan Perhentian	Datang	Berangkat	Keterangan
1	Medan (MDN)		19:35:00	X KA U95
2	Binjai (BIJ)	19:57:00		(KA U97 X)

KA U99 (Sri Lelawangsa) Relasi BIJ-MDN

No.	Stasiun dan Perhentian	Datang	Berangkat	Keterangan
1	Binjai (BIJ)		22:15:00	X KA U100
2	Medan (MDN)	22:37:00		

KA U100 (Sri Lelawangsa) Relasi MDN-BIJ

No.	Stasiun dan Perhentian	Datang	Berangkat	Keterangan
1	Medan (MDN)		21:25:00	X KA U97
2	Binjai (BIJ)	21:47:00		(KA U99 X)

A.N. Direktur Operasi
OMR



IQBAL T ISKANDAR
NIPP. 44330

PT. KERETA API INDONESIA (Persero)
KANTOR PUSAT - BANDUNG

Toka: 12310, 12320, 12321, 12311 Fax: -

DAFTAR WAKTU

Berlaku pada Gapeka 2023

ISI:

1. KA U105 (Cut Meutia) Relasi KBL - KRG
KA U106 (Cut Meutia) Relasi KRG - KBL
KA U107 (Cut Meutia) Relasi KBL - KRG
KA U108 (Cut Meutia) Relasi KRG - KBL
KA U109 (Cut Meutia) Relasi KBL - KRG
KA U110 (Cut Meutia) Relasi KRG - KBL
KA U111 (Cut Meutia) Relasi KBL - BKH
KA U112 (Cut Meutia) Relasi KRG - KBL

2. KRD EKONOMI

3. Untuk keperluan angkutan penumpang

4. Puncak kecepatan lintas:

KBL - KRM = 30 Km/Jam

KRM - KRG = 40 Km/Jam

5. KA tersebut perjalanannya sesuai dengan GAPEKA.

6. EVP / VP, Manager Op, Manager Sarana Divre 1 Mdn, atur dinasan lok rangkaian dan awak KA-nya.

7. Memberhentikan luar biasa (BLB) suatu KA harus sesuai dengan PD 19 jilid 1 pasal 86.

KA U105 (Cut Meutia) Relasi KBL-KRG

No.	Stasiun dan Perhentian	Datang	Berangkat	Keterangan
1	Kutablang (KBL)		08:35:00	X KA U106
2	Geurogok (GRK)	08:49:00	08:51:00	
3	Kruengmane (KRM)	09:07:00	09:09:00	
4	Bungkaih (BKH)	09:21:00	09:23:00	
5	Kruenggeukueh (KRG)	09:38:00		(KA U108 X)

KA U106 (Cut Meutia) Relasi KRG-KBL

No.	Stasiun dan Perhentian	Datang	Berangkat	Keterangan
1	Kruenggeukueh (KRG)		07:20:00	X KA RU106-1
2	Bungkaih (BKH)	07:35:00	07:37:00	
3	Kruengmane (KRM)	07:49:00	07:51:00	
4	Geurogok (GRK)	08:07:00	08:09:00	
5	Kutablang (KBL)	08:23:00		(KA 105 X)

KA U107 (Cut Meutia) Relasi KBL-KRG

No.	Stasiun dan Perhentian	Datang	Berangkat	Keterangan
1	Kutablang (KBL)		11:05:00	X KA U108
2	Geurogok (GRK)	11:19:00	11:21:00	
3	Kruengmane (KRM)	11:37:00	11:39:00	
4	Bungkaih (BKH)	11:51:00	11:53:00	
5	Kruenggeukueh (KRG)	12:08:00		

KA U108 (Cut Meutia) Relasi KRG-KBL

No.	Stasiun dan Perhentian	Datang	Berangkat	Keterangan
1	Kruenggeukueh (KRG)		09:50:00	X KA U105
2	Bungkaih (BKH)	10:05:00	10:07:00	
3	Kruengmane (KRM)	10:19:00	10:21:00	
4	Geurogok (GRK)	10:37:00	10:39:00	
5	Kutablang (KBL)	10:53:00		(KA U107 X)

KA U109 (Cut Meutia) Relasi KBL-KRG

No.	Stasiun dan Perhentian	Datang	Berangkat	Keterangan
1	Kutablang (KBL)		15:05:00	X KA U110
2	Geurogok (GRK)	15:19:00	15:21:00	
3	Kruengmane (KRM)	15:37:00	15:39:00	
4	Bungkaih (BKH)	15:51:00	15:53:00	
5	Kruenggeukueh (KRG)	16:08:00		(KA U112 X)

KA U110 (Cut Meutia) Relasi KRG-KBL

No.	Stasiun dan Perhentian	Datang	Berangkat	Keterangan
1	Kruenggeukueh (KRG)		13:50:00	
2	Bungkaih (BKH)	14:05:00	14:07:00	
3	Kruengmane (KRM)	14:19:00	14:21:00	
4	Geurogok (GRK)	14:37:00	14:39:00	
5	Kutablang (KBL)	14:53:00		(KA U109 X)

KA U111 (Cut Meutia) Relasi KBL-BKH

No.	Stasiun dan Perhentian	Datang	Berangkat	Keterangan
1	Kutablang (KBL)		17:35:00	X KA U112
2	Geurogok (GRK)	17:49:00	17:51:00	
3	Kruengmane (KRM)	18:07:00	18:09:00	
4	Bungkaih (BKH)	18:21:00		

KA U112 (Cut Meutia) Relasi KRG-KBL

No.	Stasiun dan Perhentian	Datang	Berangkat	Keterangan
1	Kruenggeukueh (KRG)		16:20:00	X KA U109
2	Bungkaih (BKH)	16:35:00	16:37:00	
3	Kruengmane (KRM)	16:49:00	16:51:00	
4	Geurogok (GRK)	17:07:00	17:09:00	
5	Kutablang (KBL)	17:23:00		(KA U111 X)

A.N. Direktur Operasi
OMR

IQBAL T ISKANDAR
NIPP. 44330

PT. KERETA API INDONESIA (Persero)
KANTOR PUSAT - BANDUNG

Toka: 12310, 12320, 12321, 12311 Fax: -

DAFTAR WAKTU

Berlaku pada Gapeka 2023

ISI:

1. KA 2801 (Sitarbu Ekspres) Relasi SIR - LBU
KA 2802 (Sitarbu Ekspres) Relasi LBU - SIR
KA 2803 (Kisarbu Ekspres) Relasi KIS - LBU
KA 2804 (Kisarbu Ekspres) Relasi LBU - KIS

2. BARANG

3. Untuk keperluan angkutan barang

4. Puncak kecepatan lintas:

SIR - LBU = 60 Km/Jam

5. KA tersebut perjalanannya sesuai dengan GAPEKA.

6. EVP / VP, Manager Op, Manager Sarana Divre 1 Mdn, atur dinasan lok rangkaian dan awak KA-nya.

7. Memberhentikan luar biasa (BLB) suatu KA harus sesuai dengan PD 19 jilid 1 pasal 86.

KA 2801 (Sitarbu Ekspres) Relasi SIR-LBU

No.	Stasiun dan Perhentian	Datang	Berangkat	Keterangan
1	Siantar (SIR)		12:35:00	
2	Dolok Merangir (DMR)	Ls	13:01:00	
3	Baja Linggei (BJL)	13:10:00	13:12:00	
4	Tebing Tinggi (TBI)	13:42:00	13:52:00	X KA U78 (KA U78 X)
5	Bamban (BMB)	Ls	14:08:00	
6	Rampah (RPH)	14:17:00	14:23:00	X KA U74 (KA U74 X)
7	Teluk Mengkudu (TKE)	Ls	14:33:00	
8	Lidah Tanah (LDT)	Ls	14:46:00	
9	Perbaungan (PBA)	Ls	14:56:00	
10	Lubuk Pakam (LBP)	Ls	15:08:00	
11	Araskabu (ARB)	15:18:00	15:20:00	
12	Batang Kuis (BTK)	Ls	15:31:00	
13	Bandar Kalipah (BAP)	15:40:00	15:42:00	
14	Medan (MDN)	15:57:00	16:10:00	(KA U54 X)
15	Pulu Brayan (PUB)	16:18:00	16:32:00	X KA L2843-2 (KA L2843-2 X)
16	Titi Papan (TPP)	Ls	-	
17	Labuan (LBU)	16:49:00		(KA L2811-2 X)

KA 2802 (Sitarbu Ekspres) Relasi LBU-SIR

No.	Stasiun dan Perhentian	Datang	Berangkat	Keterangan
1	Labuan (LBU)		00:15:00	X KA L2804-1
2	Titi Papan (TPP)	Ls	-	
3	Pulu Brayan (PUB)	00:32:00	00:34:00	
4	Medan (MDN)	00:42:00	00:52:00	X KA 2813 (KA 2813 X)
5	Bandar Kalipah (BAP)	01:07:00	01:09:00	(KA 2819 X)
6	Batang Kuis (BTK)	Ls	01:18:00	
7	Araskabu (ARB)	01:29:00	01:38:00	X KA 2815
8	Lubuk Pakam (LBP)	01:50:00	02:12:00	X KA 2821 (KA 2821 X)
9	Perbaungan (PBA)	Ls	02:25:00	
10	Lidah Tanah (LDT)	02:37:00	02:45:00	X KA U55 (KA U55 X)
11	Teluk Mengkudu (TKE)	Ls	02:58:00	X KA 2823 (KA 2823 X)
12	Rampah (RPH)	Ls	03:07:00	
13	Bamban (BMB)	Ls	03:15:00	
14	Tebing Tinggi (TBI)	03:32:00	04:00:00	(KA 2845F JJ X)
15	Baja Linggei (BJL)	04:30:00	04:32:00	
16	Dolok Merangir (DMR)	04:43:00	04:58:00	
17	Siantar (SIR)	05:25:00		(KA L2802-3 X)

KA 2803 (Kisarbu Ekspres) Relasi KIS-LBU

No.	Stasiun dan Perhentian	Datang	Berangkat	Keterangan
1	Kisaran (KIS)		14:50:00	X KA 2818

No.	Stasiun dan Perhentian	Datang	Berangkat	Keterangan
2	Bunut (BUU)	Ls	14:56:00	
3	Seibejangkar (SBJ)	Ls	15:12:00	
4	Dusun (DSU)	Ls	15:20:00	
5	Lima Puluh (LMP)	15:37:00	15:47:00	X KA U74 (KA U74 X)
6	Perlanaan (PRA)	Ls	15:56:00	
7	Bahlias (BLI)	Ls	16:02:00	
8	Bandar Tinggi (BDT)	Ls	16:16:00	
9	Laut Tador (LTD)	Ls	16:23:00	
10	Tebing Tinggi (TBI)	16:39:00	16:51:00	
11	Bamban (BMB)	Ls	17:07:00	
12	Rampah (RPH)	17:16:00	17:23:00	X KA U54 (KA U54 X)
13	Teluk Mengkudu (TKE)	Ls	17:33:00	
14	Lidah Tanah (LDT)	Ls	17:46:00	
15	Perbaungan (PBA)	Ls	17:56:00	
16	Lubuk Pakam (LBP)	18:07:00	18:20:00	X KA U60F JJ (KA U60F JJ X)
17	Araskabu (ARB)	18:31:00	18:33:00	
18	Batang Kuis (BTK)	Ls	18:44:00	
19	Bandar Kalipah (BAP)	18:53:00	19:07:00	X KA U76
20	Medan (MDN)	19:24:00	19:35:00	
21	Pulu Brayan (PUB)	19:43:00	20:02:00	X KA U104F JJ (KA U104F JJ, RU80F JJ X)
22	Titi Papan (TPP)	Ls	-	
23	Labuan (LBU)	20:20:00		(KA L2803-2 X)

KA 2804 (Kisarbu Ekspres) Relasi LBU-KIS

No.	Stasiun dan Perhentian	Datang	Berangkat	Keterangan
1	Labuan (LBU)		01:18:00	X KA 2813
2	Titi Papan (TPP)	Ls	-	
3	Pulu Brayan (PUB)	01:35:00	01:37:00	
4	Medan (MDN)	01:45:00	02:18:00	X KA 2819, 2815 (KA 2819, 2815 X)
5	Bandar Kalipah (BAP)	02:33:00	02:35:00	(KA 2821 X)
6	Batang Kuis (BTK)	Ls	02:45:00	
7	Araskabu (ARB)	02:58:00	03:17:00	X KA U55
8	Lubuk Pakam (LBP)	03:30:00	03:48:00	X KA 2823 (KA 2823 X)
9	Perbaungan (PBA)	Ls	04:00:00	
10	Lidah Tanah (LDT)	Ls	04:09:00	
11	Teluk Mengkudu (TKE)	Ls	04:21:00	X KA 2845F JJ (KA 2845F JJ X)
12	Rampah (RPH)	Ls	04:30:00	
13	Bamban (BMB)	Ls	04:38:00	
14	Tebing Tinggi (TBI)	04:54:00	05:10:00	
15	Laut Tador (LTD)	Ls	05:26:00	
16	Bandar Tinggi (BDT)	Ls	05:33:00	
17	Bahlias (BLI)	Ls	05:47:00	
18	Perlanaan (PRA)	Ls	05:53:00	

No.	Stasiun dan Perhentian	Datang	Berangkat	Keterangan
19	Lima Puluh (LMP)	Ls	06:00:00	
20	Dusun (DSU)	Ls	06:15:00	
21	Seibejangkar (SBJ)	Ls	06:23:00	
22	Bunut (BUU)	Ls	06:39:00	
23	Kisaran (KIS)	06:46:00		

A.N. Direktur Operasi
OMR

IQBAL T ISKANDAR
NIPP. 44330

PT. KERETA API INDONESIA (Persero)

KANTOR PUSAT - BANDUNG

Toka: 12310, 12320, 12321, 12311 Fax: -

DAFTAR WAKTU

Berlaku pada Gapeka 2023

ISI:

- | | |
|---|---|
| 1. KA 2813 (Tebel CPO) Relasi TBI - BLW | KA 2827 (Siberkis CPO) Relasi KIS - SBJ |
| KA 2814 (Tebel CPO) Relasi BLW - TBI | KA 2828 (Siberkis CPO) Relasi SBJ - KIS |
| KA 2815 (Pranabel CPO) Relasi PRA - BLW | KA 2829 (Dolbing CPO) Relasi DMR - TBI |
| KA 2816 (Pranabel CPO) Relasi BLW - PRA | KA 2830 (Dolbing CPO) Relasi TBI - DMR |
| KA 2817 (Kisabel Cpo) Relasi KIS - BLW | KA 2831F (Ranbaku Cpo) Relasi RAP - BDT |
| KA 2818 (Kisabel Cpo) Relasi BLW - KIS | KA 2832F (Ranbaku Cpo) Relasi BDT - KTJ |
| KA 2819 (Pahabel CPO) Relasi PHA - BLW | KA 2833F (Ranbaku Cpo) Relasi KTJ - BDT |
| KA 2820 (Pahabel CPO) Relasi BLW - PHA | KA 2834F (Ranbaku Cpo) Relasi BDT - RAP |
| KA 2821 (Ranpabel CPO) Relasi RAP - BLW | KA 2835F (Ranbaku Cpo) Relasi RAP - BDT |
| KA 2822 (Ranpabel CPO) Relasi BLW - RA | KA 2836F (Ranbaku Cpo) Relasi BDT - KTJ |
| KA 2823 (Ranpabel CPO) Relasi RAP - BLW | KA 2837F (Ranbaku Cpo) Relasi KTJ - BDT |
| KA 2824 (Ranpabel CPO) Relasi BLW - RAP | KA 2838F (Ranbaku Cpo) Relasi BDT - RAP |
| KA 2825 (Purjakis CPO) Relasi PUR - KIS | KA 2811 (Perbabel Cpo) Relasi PBA - BLW |
| KA 2826 (Purjakis CPO) Relasi KIS - PUR | KA 2812 (Perbabel Cpo) Relasi BLW - PBA |

2. BARANG

3. Untuk keperluan angkutan barang

4. Puncak kecepatan lintas:

TBI - LBU = 60 Km/Jam
LBU - BLW = 45 Km/Jam

RAP - BDT = 60 Km/Jam
KTJ - BDT = 40 Km/Jam

PRA - LBU = 60 Km/Jam
LBU - BLW = 45 Km/Jam

PBA - LBU = 60 Km/Jam
LBU - BLW = 45 Km/Jam

KIS - LBU = 60 Km/Jam
LBU - BLW = 45 Km/Jam

PHA - LBU = 60 Km/Jam
LBU - BLW = 45 Km/Jam

RAP - LBU = 60 Km/Jam
LBU - BLW = 45 Km/Jam

PUR - KIS = 60 Km/Jam
KIS - SBJ = 60 Km/Jam
DMR - TBI = 60 Km/Jam

5. KA tersebut perjalanannya sesuai dengan GAPEKA.

6. EVP / VP, Manager Op, Manager Sarana Divre 1 Mdn, atur dinasan lok rangkaian dan awak KA-nya.

7. Memberhentikan luar biasa (BLB) suatu KA harus sesuai dengan PD 19 jilid 1 pasal 86.

KA 2813 (Tebel CPO) Relasi TBI-BLW

No.	Stasiun dan Perhentian	Datang	Berangkat	Keterangan
1	Tebing Tinggi (TBI)		21:11:00	
2	Bamban (BMB)	Ls	21:27:00	
3	Rampah (RPH)	Ls	21:35:00	
4	Teluk Mengkudu (TKE)	21:45:00	21:52:00	X KA U80F JJ (KA U80F JJ X)
5	Lidah Tanah (LDT)	Ls	22:05:00	
6	Perbaungan (PBA)	Ls	22:14:00	
7	Lubuk Pakam (LBP)	Ls	22:25:00	
8	Araskabu (ARB)	22:35:00	22:37:00	(KA 2820 X)
9	Batang Kuis (BTK)	Ls	22:47:00	
10	Bandar Kalipah (BAP)	22:56:00	00:03:00	X KA 2822 = KA U49, U75 (KA U49, U75 //)
11	Medan (MDN)	00:18:00	00:45:00	X KA 2814, 2802, LU99-2 (KA 2814, 2802 X)
12	Pulu Brayan (PUB)	00:53:00	00:59:00	X KA 2824 (KA 2824 X)
13	Titi Papan (TPP)	Ls	-	
14	Labuan (LBU)	Ls	01:15:00	(KA 2804 X)
15	Belawan (BLW)	01:25:00		(KA 2816 X)

KA 2814 (Tebel CPO) Relasi BLW-TBI

No.	Stasiun dan Perhentian	Datang	Berangkat	Keterangan
1	Belawan (BLW)		23:22:00	X KA 2817
2	Labuan (LBU)	Ls	23:32:00	
3	Titi Papan (TPP)	Ls	-	
4	Pulu Brayan (PUB)	23:48:00	23:52:00	X KA L2804-1 (KA L2804-1 X)
5	Medan (MDN)	00:00:00	00:20:00	X KA 2813 (KA RU75, 2813 X)
6	Bandar Kalipah (BAP)	00:35:00	00:37:00	
7	Batang Kuis (BTK)	Ls	00:46:00	
8	Araskabu (ARB)	00:57:00	01:01:00	X KA 2819
9	Lubuk Pakam (LBP)	01:13:00	01:25:00	X KA 2815 (KA 2815 X)
10	Perbaungan (PBA)	Ls	01:37:00	
11	Lidah Tanah (LDT)	Ls	01:47:00	X KA 2821 (KA 2821 X)
12	Teluk Mengkudu (TKE)	Ls	01:59:00	X KA 2823 (KA 2823 X)
13	Rampah (RPH)	Ls	02:08:00	
14	Bamban (BMB)	02:17:00	02:24:00	X KA U55 (KA U55 X)
15	Tebing Tinggi (TBI)	02:42:00		

KA 2815 (Pranabel CPO) Relasi PRA-BLW

No.	Stasiun dan Perhentian	Datang	Berangkat	Keterangan
1	Perlanaan (PRA)		22:10:00	
2	Bahlias (BLI)	Ls	22:17:00	
3	Bandar Tinggi (BDT)	Ls	22:32:00	
4	Laut Tador (LTD)	Ls	22:39:00	

No.	Stasiun dan Perhentian	Datang	Berangkat	Keterangan
5	Tebing Tinggi (TBI)	22:55:00	23:15:00	
6	Bamban (BMB)	Ls	23:32:00	
7	Rampah (RPH)	Ls	23:40:00	
8	Teluk Mengkudu (TKE)	23:50:00	00:25:00	X KA U56, 2820 (KA U56, 2820 X)
9	Lidah Tanah (LDT)	00:42:00	01:02:00	X KA 2822 (KA 2822 X)
10	Perbaungan (PBA)	Ls	01:12:00	
11	Lubuk Pakam (LBP)	Ls	01:23:00	X KA 2814 (KA 2814 X)
12	Araskabu (ARB)	01:33:00	01:35:00	(KA 2802 X)
13	Batang Kuis (BTK)	Ls	01:46:00	
14	Bandar Kalipah (BAP)	01:55:00	01:57:00	X KA 2824
15	Medan (MDN)	02:12:00	02:22:00	X KA 2804, LL4 (KA 2804 X)
16	Pulu Brayan (PUB)	02:30:00	02:43:00	X KA 2816 (KA 2816 X)
17	Titi Papan (TPP)	Ls	-	
18	Labuan (LBU)	Ls	02:59:00	X KA 2842 (KA 2842 X)
19	Belawan (BLW)	03:09:00		(KA 2844 X)

KA 2816 (Pranabel CPO) Relasi BLW-PRA

No.	Stasiun dan Perhentian	Datang	Berangkat	Keterangan
1	Belawan (BLW)		02:00:00	X KA 2813
2	Labuan (LBU)	02:11:00	02:22:00	X KA 2819 (KA 2819 X)
3	Titi Papan (TPP)	Ls	-	
4	Pulu Brayan (PUB)	02:39:00	02:41:00	X KA 2815 (KA 2815 X)
5	Medan (MDN)	02:49:00	03:15:00	X KA 2821 (KA LU82-1, 2821 X)
6	Bandar Kalipah (BAP)	03:30:00	03:34:00	(KA U55 X)
7	Batang Kuis (BTK)	Ls	03:43:00	
8	Araskabu (ARB)	03:54:00	04:10:00	X KA 2823
9	Lubuk Pakam (LBP)	Ls	04:20:00	
10	Perbaungan (PBA)	Ls	04:31:00	
11	Lidah Tanah (LDT)	Ls	04:40:00	X KA 2845F JJ (KA 2845F JJ X)
12	Teluk Mengkudu (TKE)	Ls	04:52:00	
13	Rampah (RPH)	Ls	05:01:00	
14	Bamban (BMB)	Ls	05:09:00	
15	Tebing Tinggi (TBI)	05:25:00	05:50:00	
16	Laut Tador (LTD)	Ls	06:06:00	
17	Bandar Tinggi (BDT)	Ls	06:14:00	
18	Bahlias (BLI)	Ls	06:29:00	
19	Perlanaan (PRA)	06:36:00		

KA 2817 (Kisabel Cpo) Relasi KIS-BLW

No.	Stasiun dan Perhentian	Datang	Berangkat	Keterangan
1	Kisaran (KIS)		17:45:00	
2	Bunut (BUU)	Ls	17:51:00	
3	Seibejangkar (SBJ)	Ls	18:07:00	

No.	Stasiun dan Perhentian	Datang	Berangkat	Keterangan
4	Dusun (DSU)	Ls	18:15:00	
5	Lima Puluh (LMP)	18:31:00	18:40:00	X KA U54 (KA U54 X)
6	Perlanaan (PRA)	Ls	18:48:00	
7	Bahlias (BLI)	Ls	18:54:00	
8	Bandar Tinggi (BDT)	Ls	19:08:00	
9	Laut Tador (LTD)	19:16:00	19:32:00	X KA U60F JJ (KA U60F JJ X)
10	Tebing Tinggi (TBI)	19:50:00	20:00:00	
11	Bamban (BMB)	20:18:00	20:25:00	X KA U76 (KA U76 X)
12	Rampah (RPH)	Ls	20:34:00	
13	Teluk Mengkudu (TKE)	Ls	20:43:00	
14	Lidah Tanah (LDT)	Ls	20:55:00	
15	Perbaungan (PBA)	Ls	21:04:00	
16	Lubuk Pakam (LBP)	21:16:00	21:24:00	X KA U80F JJ (KA U80F JJ X)
17	Araskabu (ARB)	21:35:00	21:37:00	
18	Batang Kuis (BTK)	Ls	21:48:00	
19	Bandar Kalipah (BAP)	21:57:00	22:07:00	X KA 2820
20	Medan (MDN)	22:22:00	22:31:00	X KA RU56
21	Pulu Brayan (PUB)	22:39:00	22:54:00	X KA 2822 (KA 2822 X)
22	Titi Papan (TPP)	Ls	-	
23	Labuan (LBU)	Ls	23:10:00	
24	Belawan (BLW)	23:20:00		(KA 2814 X)

KA 2818 (Kisabel Cpo) Relasi BLW-KIS

No.	Stasiun dan Perhentian	Datang	Berangkat	Keterangan
1	Belawan (BLW)		08:00:00	
2	Labuan (LBU)	Ls	08:10:00	
3	Titi Papan (TPP)	Ls	-	
4	Pulu Brayan (PUB)	08:26:00	08:28:00	X KA R3903
5	Medan (MDN)	08:36:00	08:59:00	
6	Bandar Kalipah (BAP)	09:14:00	09:35:00	(KA U77 X) = KA U16 (KA U16 //)
7	Batang Kuis (BTK)	Ls	09:44:00	
8	Araskabu (ARB)	09:55:00	09:57:00	
9	Lubuk Pakam (LBP)	10:08:00	10:18:00	X KA U59F JJ (KA U59F JJ X)
10	Perbaungan (PBA)	Ls	10:30:00	
11	Lidah Tanah (LDT)	Ls	10:39:00	
12	Teluk Mengkudu (TKE)	Ls	10:51:00	
13	Rampah (RPH)	11:02:00	11:10:00	X KA U71 (KA U71 X)
14	Bamban (BMB)	Ls	11:20:00	
15	Tebing Tinggi (TBI)	11:37:00	12:51:00	X KA U51 (KA U51 X) = KA U58 (KA U58 //)
16	Laut Tador (LTD)	Ls	13:07:00	
17	Bandar Tinggi (BDT)	Ls	13:15:00	
18	Bahlias (BLI)	Ls	13:30:00	

No.	Stasiun dan Perhentian	Datang	Berangkat	Keterangan
19	Perlanaan (PRA)	Ls	13:36:00	
20	Lima Puluh (LMP)	13:45:00	13:56:00	X KA U73 (KA U73 X)
21	Dusun (DSU)	Ls	14:12:00	
22	Seibejangkar (SBJ)	Ls	14:20:00	
23	Bunut (BUU)	Ls	14:36:00	
24	Kisaran (KIS)	14:42:00		(KA 2803, 2827 X)

KA 2819 (Pahabel CPO) Relasi PHA-BLW

No.	Stasiun dan Perhentian	Datang	Berangkat	Keterangan
1	Padang Halaban (PHA)		18:15:00	
2	Pamienke (PME)	Ls	18:29:00	
3	Situngir (SIU)	Ls	18:49:00	
4	Membang Muda (MBM)	Ls	19:00:00	
5	Aekloba (AKB)	Ls	19:13:00	
6	Puluraja (PUR)	Ls	19:20:00	
7	Teluk Dalam (TUK)	19:40:00	19:47:00	X KA U54 (KA U54 X)
8	Hengelo (HL)	Ls	19:54:00	
9	Kisaran (KIS)	20:15:00	20:43:00	X KA U60F JJ
10	Bunut (BUU)	Ls	20:49:00	
11	Seibejangkar (SBJ)	Ls	21:05:00	
12	Dusun (DSU)	Ls	21:12:00	
13	Lima Puluh (LMP)	Ls	21:27:00	
14	Perlanaan (PRA)	21:35:00	21:41:00	X KA U76 (KA U76 X)
15	Bahlias (BLI)	Ls	21:49:00	
16	Bandar Tinggi (BDT)	Ls	22:05:00	
17	Laut Tador (LTD)	Ls	22:13:00	
18	Tebing Tinggi (TBI)	22:30:00	22:45:00	X KA U80
19	Bamban (BMB)	Ls	23:04:00	
20	Rampah (RPH)	Ls	23:13:00	
21	Teluk Mengkudu (TKE)	Ls	23:23:00	
22	Lidah Tanah (LDT)	23:37:00	00:12:00	X KA U56, 2820 (KA U56, 2820 X)
23	Perbaungan (PBA)	Ls	00:22:00	
24	Lubuk Pakam (LBP)	00:34:00	00:40:00	X KA 2822 (KA 2822 X)
25	Araskabu (ARB)	00:51:00	00:59:00	(KA 2814 X)
26	Batang Kuis (BTK)	Ls	01:10:00	
27	Bandar Kalipah (BAP)	01:19:00	01:21:00	X KA 2802
28	Medan (MDN)	01:36:00	01:54:00	X KA 2824, LU75-2, 2804 (KA 2824, 2804 X)
29	Pulu Brayan (PUB)	02:02:00	02:04:00	X KA LL4 (KA LL4 X)
30	Titi Papan (TPP)	Ls	-	
31	Labuan (LBU)	Ls	02:20:00	X KA 2816 (KA 2816 X)
32	Belawan (BLW)	02:30:00		(KA 2842 X)

KA 2820 (Pahabel CPO) Relasi BLW-PHA

No.	Stasiun dan Perhentian	Datang	Berangkat	Keterangan
1	Belawan (BLW)		21:00:00	X KA 2841
2	Labuan (LBU)	Ls	21:10:00	
3	Titi Papan (TPP)	Ls	-	
4	Pulu Brayan (PUB)	21:26:00	21:28:00	
5	Medan (MDN)	21:36:00	21:50:00	X KA U47, 2851F JJ (KA L2802-1, 2851F JJ X)
6	Bandar Kalipah (BAP)	22:05:00	22:09:00	(KA 2817 X)
7	Batang Kuis (BTK)	Ls	22:18:00	
8	Araskabu (ARB)	22:29:00	22:39:00	X KA 2813
9	Lubuk Pakam (LBP)	22:50:00	23:49:00	X KA U75 (KA U75 X) = KA U56 (KA U56 //)
10	Perbaungan (PBA)	Ls	00:01:00	
11	Lidah Tanah (LDT)	Ls	00:10:00	X KA 2819 (KA 2819 X)
12	Teluk Mengkudu (TKE)	Ls	00:22:00	X KA 2815 (KA 2815 X)
13	Rampah (RPH)	Ls	00:31:00	
14	Bamban (BMB)	00:40:00	00:47:00	X KA 2821 (KA 2821 X)
15	Tebing Tinggi (TBI)	01:05:00	01:15:00	X KA 2823 (KA 2823 X)
16	Laut Tador (LTD)	Ls	01:32:00	
17	Bandar Tinggi (BDT)	01:41:00	01:48:00	X KA U55 (KA U55 X)
18	Bahlias (BLI)	Ls	02:03:00	
19	Perlanaan (PRA)	Ls	02:09:00	X KA 2845F JJ (KA 2845F JJ X)
20	Lima Puluh (LMP)	Ls	02:16:00	
21	Dusun (DSU)	Ls	02:31:00	
22	Seibejangkar (SBJ)	Ls	02:39:00	X KA 2831F JJ (KA 2831F JJ X)
23	Bunut (BUU)	Ls	02:57:00	
24	Kisaran (KIS)	03:03:00	03:35:00	X KA 2835F JJ (KA 2835F JJ X)
25	Hengelo (HL)	Ls	03:55:00	
26	Teluk Dalam (TUK)	Ls	04:01:00	
27	Puluraja (PUR)	Ls	04:22:00	
28	Aekloba (AKB)	Ls	04:29:00	
29	Membang Muda (MBM)	Ls	04:43:00	
30	Situngir (SIU)	Ls	04:55:00	
31	Pamienke (PME)	Ls	05:16:00	
32	Padang Halaban (PHA)	05:30:00		

KA 2821 (Ranpabel CPO) Relasi RAP-BLW

No.	Stasiun dan Perhentian	Datang	Berangkat	Keterangan
1	Rantau Prapat (RAP)		18:50:00	
2	Marbau (MBU)	Ls	19:15:00	X KA LL6 (KA LL6 X)
3	Padang Halaban (PHA)	Ls	19:23:00	
4	Pamienke (PME)	Ls	19:36:00	
5	Situngir (SIU)	Ls	19:57:00	
6	Membang Muda (MBM)	20:11:00	20:22:00	X KA U54 (KA U54 X)
7	Aekloba (AKB)	Ls	20:37:00	

No.	Stasiun dan Perhentian	Datang	Berangkat	Keterangan
8	Puluraja (PUR)	Ls	20:45:00	
9	Teluk Dalam (TUK)	Ls	21:06:00	
10	Hengelo (HL)	Ls	21:12:00	
11	Kisaran (KIS)	21:33:00	21:47:00	
12	Bunut (BUU)	Ls	21:53:00	
13	Seibejangkar (SBJ)	22:10:00	22:17:00	X KA U76 (KA U76 X)
14	Dusun (DSU)	Ls	22:27:00	
15	Lima Puluh (LMP)	Ls	22:44:00	
16	Perlanaan (PRA)	Ls	22:51:00	
17	Bahlias (BLI)	Ls	22:57:00	
18	Bandar Tinggi (BDT)	Ls	23:11:00	
19	Laut Tador (LTD)	Ls	23:18:00	
20	Tebing Tinggi (TBI)	23:35:00	00:28:00	X KA U56 (KA U56 X)
21	Bamban (BMB)	Ls	00:45:00	X KA 2820 (KA 2820 X)
22	Rampah (RPH)	Ls	00:55:00	
23	Teluk Mengkudu (TKE)	01:06:00	01:15:00	X KA 2822 (KA 2822 X)
24	Lidah Tanah (LDT)	01:32:00	01:49:00	X KA 2814 (KA 2814 X)
25	Perbaungan (PBA)	Ls	01:59:00	
26	Lubuk Pakam (LBP)	Ls	02:10:00	X KA 2802 (KA 2802 X)
27	Araskabu (ARB)	02:20:00	02:26:00	(KA 2824 X)
28	Batang Kuis (BTK)	Ls	02:37:00	
29	Bandar Kalipah (BAP)	02:46:00	02:48:00	X KA 2804
30	Medan (MDN)	03:03:00	03:13:00	X KA 2816 (KA 2816 X)
31	Pulu Brayon (PUB)	03:21:00	03:23:00	X KA 2842 (KA RU82, 2842 X)
32	Titi Papan (TPP)	Ls	-	
33	Labuan (LBU)	Ls	03:39:00	X KA 2844 (KA 2844 X)
34	Belawan (BLW)	03:49:00		(KA 2852F JJ X)

KA 2822 (Ranpabel CPO) Relasi BLW-RAP

No.	Stasiun dan Perhentian	Datang	Berangkat	Keterangan
1	Belawan (BLW)		22:18:00	X KA 2851F JJ
2	Labuan (LBU)	22:29:00	22:35:00	X KA L2802-1
3	Titi Papan (TPP)	Ls	-	
4	Pulu Brayon (PUB)	22:52:00	23:02:00	X KA 2817, RU57F JJ (KA 2817 X)
5	Medan (MDN)	23:10:00	23:46:00	X KA U49, U75 (KA RU99 X)
6	Bandar Kalipah (BAP)	00:01:00	00:05:00	(KA 2813 X)
7	Batang Kuis (BTK)	Ls	00:14:00	
8	Araskabu (ARB)	00:26:00	00:28:00	
9	Lubuk Pakam (LBP)	Ls	00:38:00	X KA 2819 (KA 2819 X)
10	Perbaungan (PBA)	Ls	00:50:00	
11	Lidah Tanah (LDT)	Ls	01:00:00	X KA 2815 (KA 2815 X)
12	Teluk Mengkudu (TKE)	Ls	01:12:00	X KA 2821 (KA 2821 X)

No.	Stasiun dan Perhentian	Datang	Berangkat	Keterangan
13	Rampah (RPH)	Ls	01:22:00	
14	Bamban (BMB)	Ls	01:30:00	X KA 2823 (KA 2823 X)
15	Tebing Tinggi (TBI)	01:47:00	02:15:00	X KA U55 (KA U55 X)
16	Laut Tador (LTD)	02:32:00	02:40:00	X KA 2845F JJ (KA 2845F JJ X)
17	Bandar Tinggi (BDT)	Ls	02:48:00	
18	Bahlias (BLI)	Ls	03:02:00	
19	Perlanaan (PRA)	03:09:00	03:15:00	X KA 2831F JJ (KA 2831F JJ X)
20	Lima Puluh (LMP)	Ls	03:23:00	
21	Dusun (DSU)	Ls	03:38:00	
22	Seibejangkar (SBJ)	Ls	03:46:00	X KA 2835F JJ (KA 2835F JJ X)
23	Bunut (BUU)	Ls	04:03:00	
24	Kisaran (KIS)	04:09:00	04:46:00	
25	Hengelo (HL)	Ls	05:06:00	
26	Teluk Dalam (TUK)	Ls	05:12:00	
27	Puluraja (PUR)	Ls	05:32:00	
28	Aekloba (AKB)	Ls	05:39:00	
29	Membang Muda (MBM)	Ls	05:52:00	
30	Situngir (SIU)	Ls	06:04:00	
31	Pamienke (PME)	Ls	06:25:00	
32	Padang Halaban (PHA)	Ls	06:38:00	
33	Marbau (MBU)	Ls	06:46:00	
34	Rantau Prapat (RAP)	07:10:00		

KA 2823 (Ranpabel CPO) Relasi RAP-BLW

No.	Stasiun dan Perhentian	Datang	Berangkat	Keterangan
1	Rantau Prapat (RAP)		20:00:00	X KA LL6
2	Marbau (MBU)	Ls	20:24:00	
3	Padang Halaban (PHA)	Ls	20:31:00	
4	Pamienke (PME)	20:45:00	20:51:00	X KA U54 (KA U54 X)
5	Situngir (SIU)	Ls	21:13:00	
6	Membang Muda (MBM)	Ls	21:25:00	
7	Aekloba (AKB)	Ls	21:38:00	
8	Puluraja (PUR)	Ls	21:45:00	
9	Teluk Dalam (TUK)	Ls	22:04:00	
10	Hengelo (HL)	Ls	22:09:00	
11	Kisaran (KIS)	22:30:00	23:00:00	X KA U76
12	Bunut (BUU)	Ls	23:06:00	
13	Seibejangkar (SBJ)	Ls	23:22:00	
14	Dusun (DSU)	Ls	23:30:00	
15	Lima Puluh (LMP)	Ls	23:45:00	
16	Perlanaan (PRA)	Ls	23:52:00	
17	Bahlias (BLI)	Ls	23:58:00	
18	Bandar Tinggi (BDT)	Ls	00:13:00	

No.	Stasiun dan Perhentian	Datang	Berangkat	Keterangan
19	Laut Tador (LTD)	00:22:00	00:29:00	X KA U56 (KA U56 X)
20	Tebing Tinggi (TBI)	00:46:00	00:58:00	X KA 2820 (KA 2820 X)
21	Bamban (BMB)	01:16:00	01:22:00	X KA 2822 (KA 2822 X)
22	Rampah (RPH)	Ls	01:32:00	
23	Teluk Mengkudu (TKE)	01:43:00	02:51:00	X KA 2814, 2802 (KA 2814, 2802 X) = KA U55 (KA U55 //)
24	Lidah Tanah (LDT)	03:06:00	03:15:00	X KA 2824 (KA 2824 X)
25	Perbaungan (PBA)	Ls	03:25:00	
26	Lubuk Pakam (LBP)	Ls	03:36:00	X KA 2804 (KA 2804 X)
27	Araskabu (ARB)	03:46:00	03:56:00	(KA 2816 X)
28	Batang Kuis (BTK)	Ls	04:08:00	
29	Bandar Kalipah (BAP)	04:17:00	04:31:00	X KA 2842
30	Medan (MDN)	04:46:00	04:56:00	X KA 2844 (KA U4, 2844 X)
31	Pulu Brayan (PUB)	05:04:00	05:08:00	X KA 2852F JJ (KA 2852F JJ X)
32	Titi Papan (TPP)	Ls	-	
33	Labuan (LBU)	05:25:00	05:32:00	X KA 2812 (KA 2812 X)
34	Belawan (BLW)	05:43:00		(KA U102F JJ X)

KA 2824 (Ranpabel CPO) Relasi BLW-RAP

No.	Stasiun dan Perhentian	Datang	Berangkat	Keterangan
1	Belawan (BLW)		00:30:00	
2	Labuan (LBU)	Ls	00:40:00	
3	Titi Papan (TPP)	Ls	-	
4	Pulu Brayan (PUB)	00:57:00	01:01:00	X KA 2813 (KA 2813 X)
5	Medan (MDN)	01:09:00	01:38:00	X KA 2819 (KA 2819 X)
6	Bandar Kalipah (BAP)	01:53:00	01:59:00	(KA 2815 X)
7	Batang Kuis (BTK)	Ls	02:07:00	
8	Araskabu (ARB)	02:18:00	02:24:00	X KA 2821
9	Lubuk Pakam (LBP)	02:37:00	03:01:00	X KA U55 (KA U55 X)
10	Perbaungan (PBA)	Ls	03:13:00	
11	Lidah Tanah (LDT)	Ls	03:23:00	X KA 2823 (KA 2823 X)
12	Teluk Mengkudu (TKE)	Ls	03:35:00	
13	Rampah (RPH)	Ls	03:45:00	
14	Bamban (BMB)	Ls	03:54:00	X KA 2845F JJ (KA 2845F JJ X)
15	Tebing Tinggi (TBI)	04:11:00	04:30:00	
16	Laut Tador (LTD)	Ls	04:46:00	
17	Bandar Tinggi (BDT)	Ls	04:53:00	X KA 2835F JJ
18	Bahlias (BLI)	Ls	05:07:00	
19	Perlanaan (PRA)	Ls	05:13:00	
20	Lima Puluh (LMP)	Ls	05:20:00	
21	Dusun (DSU)	Ls	05:35:00	
22	Seibejangkar (SBJ)	Ls	05:43:00	
23	Bunut (BUU)	Ls	05:59:00	

No.	Stasiun dan Perhentian	Datang	Berangkat	Keterangan
24	Kisaran (KIS)	06:05:00	06:25:00	
25	Hengelo (HL)	Ls	06:45:00	
26	Teluk Dalam (TUK)	Ls	06:51:00	
27	Puluraja (PUR)	Ls	07:10:00	
28	Aekloba (AKB)	Ls	07:17:00	
29	Membang Muda (MBM)	Ls	07:30:00	
30	Situngir (SIU)	Ls	07:42:00	
31	Pamienke (PME)	Ls	08:04:00	
32	Padang Halaban (PHA)	08:19:00	08:36:00	X KA U51 (KA U51 X)
33	Marbau (MBU)	Ls	08:46:00	
34	Rantau Prapat (RAP)	09:12:00		

KA 2825 (Purjakis CPO) Relasi PUR-KIS

No.	Stasiun dan Perhentian	Datang	Berangkat	Keterangan
1	Puluraja (PUR)		14:52:00	X KA U58F JJ
2	Teluk Dalam (TUK)	Ls	15:12:00	
3	Hengelo (HL)	15:18:00	15:33:00	
4	Kisaran (KIS)	15:55:00		

KA 2826 (Purjakis CPO) Relasi KIS-PUR

No.	Stasiun dan Perhentian	Datang	Berangkat	Keterangan
1	Kisaran (KIS)		08:05:00	
2	Hengelo (HL)	08:26:00	08:46:00	
3	Teluk Dalam (TUK)	Ls	08:52:00	
4	Puluraja (PUR)	09:14:00		(KA U51 X)

KA 2827 (Siberkis CPO) Relasi KIS-SBJ

No.	Stasiun dan Perhentian	Datang	Berangkat	Keterangan
1	Kisaran (KIS)		15:05:00	X KA 2818
2	Bunut (BUU)	15:12:00	15:46:00	
3	Seibejangkar (SBJ)	16:05:00		(KA U74, 2828 X)

KA 2828 (Siberkis CPO) Relasi SBJ-KIS

No.	Stasiun dan Perhentian	Datang	Berangkat	Keterangan
1	Seibejangkar (SBJ)		16:35:00	X KA 2827
2	Bunut (BUU)	Ls	16:52:00	
3	Kisaran (KIS)	16:58:00		(KA U53 X)

KA 2829 (Dolbing CPO) Relasi DMR-TBI

No.	Stasiun dan Perhentian	Datang	Berangkat	Keterangan
1	Dolok Merangir (DMR)		17:40:00	
2	Baja Linggei (BJL)	17:51:00	17:53:00	

No.	Stasiun dan Perhentian	Datang	Berangkat	Keterangan
3	Tebing Tinggi (TBI)	18:23:00		

KA 2830 (Dolbing CPO) Relasi TBI-DMR

No.	Stasiun dan Perhentian	Datang	Berangkat	Keterangan
1	Tebing Tinggi (TBI)		06:05:00	
2	Baja Linggei (BJL)	06:35:00	06:37:00	
3	Dolok Merangir (DMR)	06:48:00		(KA U77 X)

KA 2831F (Ranbaku Cpo) Relasi RAP-BDT

No.	Stasiun dan Perhentian	Datang	Berangkat	Keterangan
1	Rantau Prapat (RAP)		23:20:00	
2	Marbau (MBU)	Ls	23:45:00	
3	Padang Halaban (PHA)	Ls	23:53:00	
4	Pamienke (PME)	Ls	00:06:00	
5	Situngir (SIU)	Ls	00:26:00	
6	Membang Muda (MBM)	Ls	00:38:00	
7	Aekloba (AKB)	Ls	00:51:00	
8	Puluraja (PUR)	Ls	00:58:00	
9	Teluk Dalam (TUK)	Ls	01:18:00	
10	Hengelo (HL)	Ls	01:23:00	
11	Kisaran (KIS)	01:44:00	02:05:00	X KA U56 (KA U56 X)
12	Bunut (BUU)	Ls	02:11:00	
13	Seibejangkar (SBJ)	02:28:00	02:41:00	X KA 2820 (KA 2820 X)
14	Dusun (DSU)	Ls	02:51:00	
15	Lima Puluh (LMP)	Ls	03:06:00	
16	Perlanaan (PRA)	Ls	03:13:00	X KA 2822 (KA 2822 X)
17	Bahliah (BLI)	Ls	03:19:00	
18	Bandar Tinggi (BDT)	03:34:00	03:59:00	

KA 2832F (Ranbaku Cpo) Relasi BDT-KTJ

No.	Stasiun dan Perhentian	Datang	Berangkat	Keterangan
1	Bandar Tinggi (BDT)	03:34:00	03:59:00	
2	Tanjung Gading (TGD)	Ls	04:13:00	
3	Lalang (LAG)	Ls	04:35:00	
4	Kuala Tanjung (KTJ)	04:43:00		(KA 2833F JJ X)

KA 2833F (Ranbaku Cpo) Relasi KTJ-BDT

No.	Stasiun dan Perhentian	Datang	Berangkat	Keterangan
1	Kuala Tanjung (KTJ)		05:15:00	X KA 2832F JJ
2	Lalang (LAG)	05:25:00	05:37:00	X KA 2836F JJ (KA 2836F JJ X)
3	Tanjung Gading (TGD)	Ls	05:58:00	
4	Bandar Tinggi (BDT)	06:10:00	06:35:00	

KA 2834F (Ranbaku Cpo) Relasi BDT-RAP

No.	Stasiun dan Perhentian	Datang	Berangkat	Keterangan
1	Bandar Tinggi (BDT)	06:10:00	06:35:00	
2	Bahlias (BLI)	Ls	06:52:00	
3	Perlanaan (PRA)	Ls	06:58:00	
4	Lima Puluh (LMP)	Ls	07:06:00	
5	Dusun (DSU)	Ls	07:23:00	
6	Seibejangkar (SBJ)	07:34:00	07:53:00	X KA U59F JJ (KA U59F JJ X)
7	Bunut (BUU)	Ls	08:12:00	
8	Kisaran (KIS)	08:18:00	09:00:00	(KA U71 X)
9	Hengelo (HL)	Ls	09:23:00	
10	Teluk Dalam (TUK)	09:32:00	09:53:00	X KA U51 (KA U51 X)
11	Puluraja (PUR)	Ls	10:13:00	
12	Aekloba (AKB)	Ls	10:20:00	
13	Membang Muda (MBM)	Ls	10:33:00	
14	Situngir (SIU)	Ls	10:45:00	
15	Pamienke (PME)	Ls	11:05:00	
16	Padang Halaban (PHA)	Ls	11:18:00	
17	Marbau (MBU)	Ls	11:26:00	
18	Rantau Prapat (RAP)	11:51:00		

KA 2835F (Ranbaku Cpo) Relasi RAP-BDT

No.	Stasiun dan Perhentian	Datang	Berangkat	Keterangan
1	Rantau Prapat (RAP)		00:15:00	
2	Marbau (MBU)	Ls	00:40:00	
3	Padang Halaban (PHA)	Ls	00:49:00	
4	Pamienke (PME)	Ls	01:03:00	
5	Situngir (SIU)	Ls	01:25:00	
6	Membang Muda (MBM)	Ls	01:37:00	
7	Aekloba (AKB)	Ls	01:51:00	
8	Puluraja (PUR)	Ls	01:59:00	
9	Teluk Dalam (TUK)	02:20:00	02:30:00	X KA U56 (KA U56 X)
10	Hengelo (HL)	Ls	02:36:00	
11	Kisaran (KIS)	02:56:00	03:11:00	X KA 2820 (KA 2820 X)
12	Bunut (BUU)	Ls	03:17:00	
13	Seibejangkar (SBJ)	03:34:00	03:48:00	X KA 2822 (KA 2822 X)
14	Dusun (DSU)	Ls	03:56:00	
15	Lima Puluh (LMP)	Ls	04:10:00	
16	Perlanaan (PRA)	Ls	04:17:00	
17	Bahlias (BLI)	Ls	04:22:00	
18	Bandar Tinggi (BDT)	04:37:00	05:02:00	(KA 2824 X)

KA 2836F (Ranbaku Cpo) Relasi BDT-KTJ

No.	Stasiun dan Perhentian	Datang	Berangkat	Keterangan
1	Bandar Tinggi (BDT)	04:37:00	05:02:00	
2	Tanjung Gading (TGD)	Ls	05:15:00	
3	Lalang (LAG)	Ls	05:35:00	X KA 2833F JJ (KA 2833F JJ X)
4	Kuala Tanjung (KTJ)	05:43:00		(KA 2837F JJ X)

KA 2837F (Ranbaku Cpo) Relasi KTJ-BDT

No.	Stasiun dan Perhentian	Datang	Berangkat	Keterangan
1	Kuala Tanjung (KTJ)		06:20:00	X KA 2836F JJ
2	Lalang (LAG)	Ls	06:28:00	
3	Tanjung Gading (TGD)	06:51:00	07:03:00	X KA U68F JJ (KA U68F JJ X)
4	Bandar Tinggi (BDT)	07:17:00	07:42:00	

KA 2838F (Ranbaku Cpo) Relasi BDT-RAP

No.	Stasiun dan Perhentian	Datang	Berangkat	Keterangan
1	Bandar Tinggi (BDT)	07:17:00	07:42:00	
2	Bahlias (BLI)	Ls	07:59:00	
3	Perlanaan (PRA)	08:07:00	08:23:00	X KA U59F JJ (KA U59F JJ X)
4	Lima Puluh (LMP)	Ls	08:32:00	
5	Dusun (DSU)	Ls	08:50:00	
6	Seibejangkar (SBJ)	09:00:00	09:13:00	X KA U71 (KA U71 X)
7	Bunut (BUU)	Ls	09:33:00	
8	Kisaran (KIS)	09:40:00	10:15:00	X KA U51 (KA U51 X)
9	Hengelo (HL)	Ls	10:37:00	
10	Teluk Dalam (TUK)	Ls	10:43:00	
11	Puluraja (PUR)	Ls	11:03:00	
12	Aekloba (AKB)	Ls	11:11:00	
13	Membang Muda (MBM)	Ls	11:25:00	
14	Situngir (SIU)	Ls	11:38:00	
15	Pamienke (PME)	Ls	11:59:00	
16	Padang Halaban (PHA)	Ls	12:13:00	
17	Marbau (MBU)	Ls	12:22:00	
18	Rantau Prapat (RAP)	12:48:00		

KA 2811 (Perbabel Cpo) Relasi PBA-BLW

No.	Stasiun dan Perhentian	Datang	Berangkat	Keterangan
1	Perbaungan (PBA)		14:12:00	X KA U74
2	Lubuk Pakam (LBP)	Ls	14:24:00	
3	Araskabu (ARB)	14:34:00	14:46:00	= KA U27 (KA U27 //)
4	Batang Kuis (BTK)	Ls	14:57:00	
5	Bandar Kalipah (BAP)	15:06:00	15:10:00	
6	Medan (MDN)	15:26:00	15:42:00	X KA RU54
7	Pulu Brayan (PUB)	15:50:00	15:52:00	
8	Titi Papan (TPP)	Ls	-	

No.	Stasiun dan Perhentian	Datang	Berangkat	Keterangan
9	Labuan (LBU)	Ls	16:08:00	X KA L2843-2 (KA L2843-2 X)
10	Belawan (BLW)	16:18:00		(KA L2811-2 X)

KA 2812 (Perbabel Cpo) Relasi BLW-PBA

No.	Stasiun dan Perhentian	Datang	Berangkat	Keterangan
1	Belawan (BLW)		05:30:00	X KA U101F JJ
2	Labuan (LBU)	Ls	05:40:00	X KA 2823 (KA 2823 X)
3	Titi Papan (TPP)	Ls	-	
4	Pulu Brayon (PUB)	05:56:00	06:05:00	X KA 2845F JJ (KA 2845F JJ X)
5	Medan (MDN)	06:13:00	06:50:00	
6	Bandar Kalipah (BAP)	07:05:00	07:07:00	
7	Batang Kuis (BTK)	Ls	07:16:00	
8	Araskabu (ARB)	07:27:00	07:29:00	
9	Lubuk Pakam (LBP)	Ls	07:40:00	
10	Perbaungan (PBA)	07:52:00		

A.N. Direktur Operasi
OMR

IQBAL T ISKANDAR
NIPP. 44330

PT. KERETA API INDONESIA (Persero)

KANTOR PUSAT - BANDUNG

Toka: 12310, 12320, 12321, 12311 Fax: -

DAFTAR WAKTU

Berlaku pada Gapeka 2023

ISI:

1. KA 2841 (Praba Cargo) Relasi PRA - BLW
KA 2842 (Praba Cargo) Relasi BLW - PRA
KA 2843 (Sitabel Cargo) Relasi SIR - BLW
KA 2844 (Sitabel Cargo) Relasi BLW - SIR
KA 2845F (Ranba Cargo) Relasi RAP - BLW
KA 2846F (Ranba Cargo) Relasi BLW - RAP
KA 2847F (Prakuta Cargo) Relasi PRA - BDT
KA 2848F (Prakuta Cargo) Relasi BDT - KTJ
KA 2849F (Prakuta Cargo) Relasi KTJ - BDT
KA 2850F (Prakuta Cargo) Relasi BDT - PRA
KA 2851F (Utaba Cargo) Relasi KTJ - BLW
KA 2852F (Utaba Cargo) Relasi BLW - KTJ

2. BARANG

3. Untuk keperluan angkutan barang
4. Puncak kecepatan lintas:

PRA - MDN = 75 Km/Jam
MDN - LBU = 70 Km/Jam
LBU - BLW = 45 Km/Jam

KTJ - BDT = 40 Km/Jam
BDT - MDN = 75 Km/Jam
MDN - LBU = 70 Km/Jam
LBU - BLW = 45 Km/Jam

SIR - MDN = 75 Km/Jam
MDN - LBU = 70 Km/Jam
LBU - BLW = 45 Km/Jam

RAP - MBU = 75 Km/Jam
MBU - MBM = 70 Km/Jam
MBM - KIS = 75 Km/Jam
KIS - PRA = 70 Km/Jam
PRA - MDN = 75 Km/Jam
MDN - LBU = 70 Km/Jam
LBU - BLW = 45 Km/Jam

PRA - BDT = 75 Km/Jam
BDT - KTJ = 40 Km/Jam

5. KA tersebut perjalanannya sesuai dengan GAPEKA.
6. EVP / VP, Manager Op, Manager Sarana Divre 1 Mdn, atur dinasan lok rangkaian dan awak KA-nya.
7. Memberhentikan luar biasa (BLB) suatu KA harus sesuai dengan PD 19 jilid 1 pasal 86.

KA 2841 (Praba Cargo) Relasi PRA-BLW

No.	Stasiun dan Perhentian	Datang	Berangkat	Keterangan
1	Perlanaan (PRA)		16:50:00	
2	Bahlias (BLI)	Ls	16:56:00	
3	Bandar Tinggi (BDT)	Ls	17:09:00	
4	Laut Tador (LTD)	Ls	17:16:00	
5	Tebing Tinggi (TBI)	17:30:00	17:45:00	X KA U54 (KA U54 X)
6	Bamban (BMB)	Ls	17:59:00	
7	Rampah (RPH)	Ls	18:06:00	
8	Teluk Mengkudu (TKE)	Ls	18:14:00	
9	Lidah Tanah (LDT)	18:25:00	18:32:00	X KA U60F JJ (KA U60F JJ X)
10	Perbaungan (PBA)	Ls	18:41:00	
11	Lubuk Pakam (LBP)	Ls	18:51:00	
12	Araskabu (ARB)	18:59:00	19:08:00	
13	Batang Kuis (BTK)	Ls	19:19:00	
14	Bandar Kalipah (BAP)	19:28:00	19:30:00	
15	Medan (MDN)	19:44:00	20:10:00	X KA RU80F JJ, U104F JJ
16	Pulu Brayan (PUB)	20:18:00	20:22:00	
17	Titi Papan (TPP)	Ls	-	
18	Labuan (LBU)	Ls	20:38:00	(KA L2803-2 X)
19	Belawan (BLW)	20:48:00		(KA 2820 X)

KA 2842 (Praba Cargo) Relasi BLW-PRA

No.	Stasiun dan Perhentian	Datang	Berangkat	Keterangan
1	Belawan (BLW)		02:40:00	X KA 2819
2	Labuan (LBU)	02:51:00	03:01:00	X KA 2815 (KA 2815 X)
3	Titi Papan (TPP)	Ls	-	
4	Pulu Brayan (PUB)	03:17:00	04:07:00	X KA 2821, LU72-1, RU55 (KA 2821 X)
5	Medan (MDN)	04:15:00	04:26:00	
6	Bandar Kalipah (BAP)	04:39:00	04:43:00	(KA 2823 X)
7	Batang Kuis (BTK)	Ls	04:51:00	
8	Araskabu (ARB)	05:01:00	05:12:00	X KA 2845F JJ
9	Lubuk Pakam (LBP)	Ls	05:22:00	
10	Perbaungan (PBA)	Ls	05:33:00	
11	Lidah Tanah (LDT)	Ls	05:42:00	
12	Teluk Mengkudu (TKE)	Ls	05:53:00	
13	Rampah (RPH)	Ls	06:02:00	
14	Bamban (BMB)	Ls	06:10:00	
15	Tebing Tinggi (TBI)	06:26:00	06:36:00	
16	Laut Tador (LTD)	Ls	06:50:00	
17	Bandar Tinggi (BDT)	Ls	06:57:00	
18	Bahlias (BLI)	Ls	07:11:00	
19	Perlanaan (PRA)	07:17:00		

KA 2843 (Sitabel Cargo) Relasi SIR-BLW

No.	Stasiun dan Perhentian	Datang	Berangkat	Keterangan
1	Siantar (SIR)		11:05:00	X KA 2844
2	Dolok Merangir (DMR)	Ls	11:26:00	
3	Baja Linggei (BJL)	11:34:00	11:36:00	
4	Tebing Tinggi (TBI)	12:00:00	12:22:00	X KA U58F JJ
5	Bamban (BMB)	Ls	12:36:00	
6	Rampah (RPH)	Ls	12:44:00	
7	Teluk Mengkudu (TKE)	Ls	12:53:00	
8	Lidah Tanah (LDT)	13:05:00	13:14:00	X KA U78 (KA U78 X)
9	Perbaungan (PBA)	Ls	13:23:00	
10	Lubuk Pakam (LBP)	13:34:00	13:40:00	X KA U74 (KA U74 X)
11	Araskabu (ARB)	13:49:00	14:09:00	= KA U25 (KA U25 //)
12	Batang Kuis (BTK)	Ls	14:20:00	
13	Bandar Kalipah (BAP)	14:28:00	14:30:00	
14	Medan (MDN)	14:43:00	14:53:00	X KA LU51-2
15	Pulu Brayan (PUB)	15:01:00	15:03:00	
16	Titi Papan (TPP)	Ls	-	
17	Labuan (LBU)	Ls	15:18:00	
18	Belawan (BLW)	15:28:00		(KA L2843-2 X)

KA 2844 (Sitabel Cargo) Relasi BLW-SIR

No.	Stasiun dan Perhentian	Datang	Berangkat	Keterangan
1	Belawan (BLW)		03:20:00	X KA 2815
2	Labuan (LBU)	03:31:00	03:41:00	X KA 2821 (KA 2821 X)
3	Titi Papan (TPP)	Ls	-	
4	Pulu Brayan (PUB)	03:58:00	04:40:00	X KA RU55
5	Medan (MDN)	04:48:00	05:14:00	X KA 2823 (KA U101F JJ, 2823 X)
6	Bandar Kalipah (BAP)	05:28:00	05:34:00	(KA 2845F JJ X)
7	Batang Kuis (BTK)	Ls	05:42:00	
8	Araskabu (ARB)	05:52:00	05:54:00	
9	Lubuk Pakam (LBP)	Ls	06:03:00	
10	Perbaungan (PBA)	Ls	06:13:00	
11	Lidah Tanah (LDT)	Ls	06:22:00	
12	Teluk Mengkudu (TKE)	Ls	06:33:00	
13	Rampah (RPH)	Ls	06:41:00	
14	Bamban (BMB)	Ls	06:49:00	
15	Tebing Tinggi (TBI)	07:04:00	07:36:00	X KA U77 (KA U77 X)
16	Baja Linggei (BJL)	08:01:00	08:03:00	
17	Dolok Merangir (DMR)	08:13:00	10:06:00	
18	Siantar (SIR)	10:30:00		(KA 2843 X)

KA 2845F (Ranba Cargo) Relasi RAP-BLW

No.	Stasiun dan Perhentian	Datang	Berangkat	Keterangan
1	Rantau Prapat (RAP)		20:45:00	
2	Marbau (MBU)	21:09:00	21:25:00	X KA U54 (KA U54 X)
3	Padang Halaban (PHA)	Ls	21:33:00	
4	Pamienke (PME)	Ls	21:44:00	
5	Situngir (SIU)	Ls	22:04:00	
6	Membang Muda (MBM)	Ls	22:15:00	
7	Aekloba (AKB)	Ls	22:27:00	
8	Puluraja (PUR)	Ls	22:34:00	
9	Teluk Dalam (TUK)	Ls	22:53:00	
10	Hengelo (HL)	Ls	22:58:00	
11	Kisaran (KIS)	23:17:00	23:50:00	
12	Bunut (BUU)	Ls	23:56:00	
13	Seibejangkar (SBJ)	Ls	00:14:00	
14	Dusun (DSU)	Ls	00:22:00	
15	Lima Puluh (LMP)	Ls	00:37:00	
16	Perlanaan (PRA)	00:45:00	02:11:00	X KA U56, 2820 (KA U56, 2820 X) = KA U55 (KA U55 //)
17	Bahlias (BLI)	Ls	02:18:00	
18	Bandar Tinggi (BDT)	Ls	02:32:00	
19	Laut Tador (LTD)	Ls	02:38:00	X KA 2822 (KA 2822 X)
20	Tebing Tinggi (TBI)	02:52:00	03:34:00	X KA 2802
21	Bamban (BMB)	03:50:00	03:56:00	X KA 2824 (KA 2824 X)
22	Rampah (RPH)	Ls	04:05:00	
23	Teluk Mengkudu (TKE)	04:15:00	04:23:00	X KA 2804 (KA 2804 X)
24	Lidah Tanah (LDT)	04:36:00	04:42:00	X KA 2816 (KA 2816 X)
25	Perbaungan (PBA)	Ls	04:51:00	
26	Lubuk Pakam (LBP)	Ls	05:00:00	
27	Araskabu (ARB)	05:08:00	05:10:00	(KA 2842 X)
28	Batang Kuis (BTK)	Ls	05:19:00	
29	Bandar Kalipah (BAP)	05:26:00	05:30:00	X KA 2844
30	Medan (MDN)	05:43:00	05:53:00	X KA 2852F JJ (KA 2852F JJ X)
31	Pulu Brayan (PUB)	06:01:00	06:03:00	X KA 2812 (KA 2812 X)
32	Titi Papan (TPP)	Ls	-	
33	Labuan (LBU)	Ls	06:18:00	X KA U102F JJ (KA U102F JJ X)
34	Belawan (BLW)	06:28:00		(KA 2846F JJ X)

KA 2846F (Ranba Cargo) Relasi BLW-RAP

No.	Stasiun dan Perhentian	Datang	Berangkat	Keterangan
1	Belawan (BLW)		06:45:00	X KA 2845F JJ
2	Labuan (LBU)	Ls	06:55:00	
3	Titi Papan (TPP)	Ls	-	
4	Pulu Brayan (PUB)	07:10:00	07:12:00	X KA LU52-1
5	Medan (MDN)	07:20:00	07:40:00	

No.	Stasiun dan Perhentian	Datang	Berangkat	Keterangan
6	Bandar Kalipah (BAP)	07:53:00	08:13:00	= KA U12 (KA U12 //)
7	Batang Kuis (BTK)	08:21:00	08:23:00	
8	Araskabu (ARB)	08:33:00	08:35:00	
9	Lubuk Pakam (LBP)	08:45:00	09:25:00	X KA U77 (KA U77 X) = KA U52 (KA U52 //)
10	Perbaungan (PBA)	Ls	09:36:00	
11	Lidah Tanah (LDT)	09:46:00	09:59:00	X KA U59F JJ (KA U59F JJ X)
12	Teluk Mengkudu (TKE)	Ls	10:10:00	
13	Rampah (RPH)	Ls	10:18:00	
14	Bamban (BMB)	Ls	10:25:00	
15	Tebing Tinggi (TBI)	10:38:00	10:57:00	X KA U71 (KA U71 X)
16	Laut Tador (LTD)	Ls	11:12:00	
17	Bandar Tinggi (BDT)	11:20:00	11:49:00	X KA U51, 2847F JJ (KA U51 X)
18	Bahlias (BLI)	Ls	12:04:00	
19	Perlanaan (PRA)	Ls	12:10:00	
20	Lima Puluh (LMP)	Ls	12:17:00	
21	Dusun (DSU)	Ls	12:32:00	
22	Seibejangkar (SBJ)	Ls	12:40:00	
23	Bunut (BUU)	Ls	12:55:00	
24	Kisaran (KIS)	13:00:00	13:12:00	(KA U73 X)
25	Hengelo (HL)	Ls	13:29:00	
26	Teluk Dalam (TUK)	Ls	13:34:00	
27	Puluraja (PUR)	Ls	13:51:00	
28	Aekloba (AKB)	Ls	13:58:00	
29	Membang Muda (MBM)	Ls	14:10:00	
30	Situngir (SIU)	Ls	14:21:00	
31	Pamienke (PME)	Ls	14:40:00	
32	Padang Halaban (PHA)	Ls	14:52:00	
33	Marbau (MBU)	15:01:00	15:09:00	X KA U53 (KA U53 X)
34	Rantau Prapat (RAP)	15:33:00		

KA 2847F (Prakuta Cargo) Relasi PRA-BDT

No.	Stasiun dan Perhentian	Datang	Berangkat	Keterangan
1	Perlanaan (PRA)		11:25:00	
2	Bahlias (BLI)	Ls	11:32:00	
3	Bandar Tinggi (BDT)	11:47:00	13:20:00	(KA 2846F JJ X)

KA 2848F (Prakuta Cargo) Relasi BDT-KTJ

No.	Stasiun dan Perhentian	Datang	Berangkat	Keterangan
1	Bandar Tinggi (BDT)	11:47:00	13:20:00	
2	Tanjung Gading (TGD)	Ls	13:34:00	
3	Lalang (LAG)	Ls	13:56:00	
4	Kuala Tanjung (KTJ)	14:05:00		

KA 2849F (Prakuta Cargo) Relasi KTJ-BDT

No.	Stasiun dan Perhentian	Datang	Berangkat	Keterangan
1	Kuala Tanjung (KTJ)		18:20:00	
2	Lalang (LAG)	Ls	18:28:00	
3	Tanjung Gading (TGD)	Ls	18:50:00	
4	Bandar Tinggi (BDT)	19:04:00	20:34:00	

KA 2850F (Prakuta Cargo) Relasi BDT-PRA

No.	Stasiun dan Perhentian	Datang	Berangkat	Keterangan
1	Bandar Tinggi (BDT)	19:04:00	20:34:00	X KA U57F JJ
2	Bahlias (BLI)	Ls	20:47:00	
3	Perlanaan (PRA)	20:53:00		(KA U75 X)

KA 2851F (Utaba Cargo) Relasi KTJ-BLW

No.	Stasiun dan Perhentian	Datang	Berangkat	Keterangan
1	Kuala Tanjung (KTJ)		17:10:00	
2	Lalang (LAG)	Ls	17:18:00	
3	Tanjung Gading (TGD)	Ls	17:40:00	
4	Bandar Tinggi (BDT)	17:54:00	18:24:00	X KA U54 = KA U53 (KA U53 //)
5	Laut Tador (LTD)	Ls	18:32:00	
6	Tebing Tinggi (TBI)	18:46:00	19:20:00	X KA U60F JJ (KA U60F JJ X)
7	Bamban (BMB)	Ls	19:38:00	
8	Rampah (RPH)	Ls	19:48:00	
9	Teluk Mengkudu (TKE)	19:59:00	20:11:00	X KA U76 (KA U76 X)
10	Lidah Tanah (LDT)	Ls	20:24:00	
11	Perbaungan (PBA)	Ls	20:34:00	
12	Lubuk Pakam (LBP)	Ls	20:46:00	
13	Araskabu (ARB)	20:56:00	20:58:00	(KA U80 F JJ X)
14	Batang Kuis (BTK)	Ls	21:07:00	
15	Bandar Kalipah (BAP)	21:15:00	21:17:00	
16	Medan (MDN)	21:30:00	21:41:00	X KA L2803-2, 2820 (KA 2820 X)
17	Pulu Brayan (PUB)	21:49:00	21:51:00	
18	Titi Papan (TPP)	Ls	-	
19	Labuan (LBU)	Ls	22:06:00	
20	Belawan (BLW)	22:16:00		(KA 2822 X)

KA 2852F (Utaba Cargo) Relasi BLW-KTJ

No.	Stasiun dan Perhentian	Datang	Berangkat	Keterangan
1	Belawan (BLW)		04:25:00	X KA 2821
2	Labuan (LBU)	Ls	04:35:00	
3	Titi Papan (TPP)	Ls	-	
4	Pulu Brayan (PUB)	04:50:00	05:20:00	X KA U101F JJ, 2823 (KA U101F JJ, 2823 X)

No.	Stasiun dan Perhentian	Datang	Berangkat	Keterangan
5	Medan (MDN)	05:30:00	06:20:00	X KA 2845F JJ (KA 2845F JJ X)
6	Bandar Kalipah (BAP)	06:33:00	06:35:00	
7	Batang Kuis (BTK)	Ls	06:43:00	
8	Araskabu (ARB)	06:52:00	06:54:00	
9	Lubuk Pakam (LBP)	Ls	07:02:00	
10	Perbaungan (PBA)	Ls	07:11:00	
11	Lidah Tanah (LDT)	Ls	07:19:00	
12	Teluk Mengkudu (TKE)	Ls	07:29:00	
13	Rampah (RPH)	Ls	07:37:00	
14	Bamban (BMB)	07:45:00	07:52:00	X KA U77 (KA U77 X)
15	Tebing Tinggi (TBI)	08:08:00	08:20:00	
16	Laut Tador (LTD)	08:36:00	08:48:00	X KA U59F JJ (KA U59F JJ X)
17	Bandar Tinggi (BDT)	08:56:00	09:07:00	X KA U67F JJ (KA U67F JJ X)
18	Tanjung Gading (TGD)	Ls	09:20:00	
19	Lalang (LAG)	Ls	09:41:00	
20	Kuala Tanjung (KTJ)	09:49:00		

A.N. Direktur Operasi
OMR

IQBAL T ISKANDAR
NIPP. 44330

LAMPIRAN IV KEPUTUSAN DIREKTUR JENDERAL
PERKERETAAPIAN

NOMOR : KP-DJKA 68 TAHUN 2023

TANGGAL : 14 APRIL 2023



**BUKU DUKUNGAN SARANA PERKERETAAPIAN
JARINGAN JALUR KERETA API NASIONAL DI
SUMATERA BAGIAN UTARA**

**KEMENTERIAN PERHUBUNGAN
DIREKTORAT JENDERAL PERKERETAAPIAN
JAKARTA 2023**



LAMPIRAN IV
NOMOR : KP - DJKA 68 TAHUN 2023
TANGGAL : 14 APRIL 2023



BUKU PEDOMAN DUKUNGAN SARANA

Jaringan Jalur Kereta Api Nasional Di Sumatera Bagian Utara

Berlaku Pada GAPEKA 2023



KANTOR PUSAT
BANDUNG 2023

PT KERETA API INDONESIA (PERSERO)

P R A K A T A

1. Sehubungan dengan pemberlakuan GAPEKA 2023 maka kami susun kembali Pola Dinas Sarana (O.18) Gapeka 2023 dan kami tetapkan sebagai **Peraturan Tambahan Dinas Operasi (PTDO) Gapeka 2023** tentang Pedoman Dinas Sarana Gapeka 2023;
2. Demi untuk memenuhi harapan stakeholder terhadap pelayanan Kereta Api yang terus meningkat, khususnya Kereta Api Penumpang, kami buat pengaturan pola operasi dengan mempertimbangkan :
 - a. Kapasitas tempat duduk bisa meningkat dengan mengoptimalkan sarana yang tersedia;
 - b. Peningkatan utilisasi sarana dengan mengefektifkan waktu Idle Rangkaian;
 - c. Meminimalisir kebutuhan jalur stabling rangkaian;
3. Buku ini sebagai **Pedoman Operasional KA** yang terdiri dari 4 (empat) bagian meliputi :
 - a. Dinas Lokomotif;
 - b. Dinas dan Stamformasi KRD;
 - c. Dinas Kereta dan Stamformasi KA Penumpang;
 - d. Dinas Gerbong dan Stamformasi KA Barang;Beserta data dukung sarannya;
4. Bilamana terdapat kekeliruan dalam penyusunan buku ini, maka akan dibuat warta dinas tentang perubahan dan tambahan seperlunya.

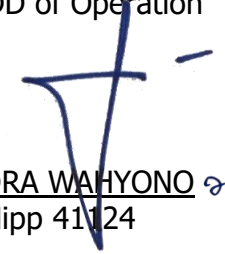
Bandung, 12 April 2023
Plt. CDD of Operation

HENDRA WAHYONO 
Nipp 41124

DASAR POLA OPERASI

1. Buku Pedoman Dinasan Sarana Gapeka 2023 ini, mengatur hal yang terkait dengan pengoperasian KA Penumpang, KA Barang dan KRD sesuai Pola Operasi GAPEKA 2023 dan didalamnya memuat tentang :
 - ~ Alat Produksi, terdiri dari : Lokomotif, KRD, Kereta dan Gerbong di Sumatera Utara ;
 - ~ Sarana Siap Guna dan Sarana Siap Operasi tiap Dipo Induk;
 - ~ Penetapan Dinasan Lok, Dinasan dan SF KRD dan SF KA Penumpang, SF KA Barang ;
 - ~ Data Produksi Sarana dan data pendukung lain;
2. Ketersediaan Armada Sarana yang termuat dalam buku ini adalah :

~ Lokomoti	31 unit
~ KRD	2 unit
~ Kereta	71 unit
~ Gerbong	305 unit
Jumlah	409 unit
3. Dengan terbitnya buku P & T ini, maka Buku PTDO Bab XI GAPEKA 2021 dan P & T tentang Dukungan Sarana Gapeka 2021 khususnya Lokomotif, KRD, Kereta dan Gerbong dinyatakan tidak berlaku lagi;
4. Demikian buku ini diterbitkan untuk menjadi Pedoman setiap Bagian dan Unit terkait dalam menentukan kebijakan pelaksanaan Operasional Kereta Api, terima kasih.

VP TRAIN OPERATION PLANNING



IQBAL T ISKANDAR ♂

Nipp : 44330

REKAP DUKUNGAN & PENDINASAN SARANA

SUMATERA UTARA

GAPEKA TAHUN 2023

NO	JENIS SARANA	SIAP GUNA	SIAP OPERASI	STAMFORMASI	CADANGAN
1	LOKOMOTIF	31	26	26	0
2	KRD	2	2	2	0
3	KERETA	71	59	52	7
4	GERBONG	305	259	226	33

CATATAN :

- ~ KRD Termasuk kepemilikan Pemprov Aceh (2 unit Rail bus)
- ~ KRD Railink tidak masuk dalam armada PT KAI (4ts / 18 unit)



KANTOR PUSAT
BANDUNG
2023

LOKOMOTIF

DINASAN LOK & KETERSEDIAAN WILAYAH SUMUT



KETERSEDIAAN LOK DAN DINASAN

SUMATERA UTARA

GAPEKA 2023

NO	URAIAN	LOK DI SUMATERA UTARA
1	SIAP GUNA	31
2	TSGO	3
3	SGO	28
4	TSO	2
5	SO	26
6	SF	26
7	CAD	0

REKAP KETERSEDIAAN LOKOMOTIF GAPEKA 2023
SUMATERA UTARA

SUMATERA UTARA

DIPO	JENIS LOKO		SIAP GUNA	TSGO	SGO	TSO	SO
MDN	1	CC 201	15	1	14	1	13
	2	BB 203	5	1	4		4
	3	BB 302	1		1		1
	4	BB 303	10	1	9	1	8
Jumlah Lok DE			20	2	18	1	17
Jumlah Lok DH			11	1	10	1	9
TOTAL LOK DI SUMATERA UTARA			31	3	28	2	26

Vice President Tractive Rail Vehicle



SOEGITO
NIPP : 41003

Vice President Train Operation Planing



IQBAL T ISKANDAR
NIPP : 44330

PT. KERETA API INDONESIA (PERSERO)

KANTOR PUSAT BANDUNG					SERI LOK					DINASAN LOKOMOTIF DIESEL														LOKOMOTIF				JUMLAH				
DIVRE : I MEDAN					BB 203 / 302 / 303																			GAPEKA TAHUN 2023								
DIPO : Medan					CC 201					Berlaku mulai tanggal 01 Juni 2023																						
																								Jumlah Km				8.072				
																								Jumlah Km sehari				448				
																								Jam dinas efektif rata-rata				11				
																								Jam dinas operasi rata-rata				24				
No	KmLok	Lok	Hari	Seri	0	1	2	3	4	5	6	7	8	9	10	11	12	13	14	15	16	17	18	19	20	21	22	23	Jam			
16	397,68	8	IV	CC 201	Blw	2824 (Ranpabel CPO)					Rap															Rap	2823 (Ranpabel CPO)				12	24
17	780,27	9	V	CC 201	2823 (Ranpabel CPO)					Blw	2812 (CPO) Pba					(Perabel CPO)				Pba	2811 (CPO)				Blw	Mdn				12	24	
18	71,34	1	I	BB 303															Kis	2826 Pur (Purjakis CPO)				Pur	2825 Kis				2	24		
19		1	I	BB 303															<i>Dinasan KLB Kerja / Langsir di Medan (Mdn)</i>													
20		1	I	BB 303															<i>Dinasan Langsir di Rantauprapat (Rap)</i>													
21.22		2.3	I	BB 303															<i>Dinasan Langsir di Belawan (Blw)</i>													
23		4	I	BB 303															<i>Dinasan Langsir di Kisaran (Kis)</i>													
24		5	I	BB 303															<i>Dinasan Langsir di Labuan (Lbu)</i>													
25		6	1	BB 303															<i>Dinasan Langsir di Tebingtinggi (Tbi)</i>													
26		1		BB 302															<i>Dinasan Langsir di Pulubrayan (Pub)</i>													
27		1		BB 303															<i>TSO 1 (Perawatan di Depo 1)</i>													
28		1		CC 201															<i>TSO 2 (Perawatan di Depo 2)</i>													
29		1		BB 203															<i>TSGO 1 (Perawatan di Balai Yasa 1)</i>													
30		1		BB 303															<i>TSGO 2 (Perawatan di Balai Yasa 2)</i>													
31		1		CC 201															<i>TSGO 3 (Perawatan di Balai Yasa 3)</i>													
Urt	KmLok	Lok	Hari	Seri	0	1	2	3	4	5	6	7	8	9	10	11	12	13	14	15	16	17	18	19	20	21	22	23	Eff	Opr		

VP TRAIN OPERATION PLANNING



IQBAL T ISKANDAR
Nipp : 44330

Eff : Jumlah Jam Efektif yang dihitung berdasar Jam Dinas KA

Opr : Jumlah Operasi yang dihitung dari Jam Efektif + Jam Lok Selama Berada Diluar Dipo Induk

KETERSEDIAAN SO & DINASAN LOK

SUMATERA UTARA

GAPEKA 2023

DIPO	LOK SO		DINAS KA PNP	DINAS KA BRG	POSKO	KLB KERJA	DINAS LANGSIR	JUMLAH	TOTAL DINASAN	LBH / KRG
	Jenis	Jumlah								
MDN	CC 201	13	4	9				13	26	0
	BB 203	4	4					4		0
	BB 302	1					1	1		0
	BB 303	8		1		1	6	8		0
JUMLAH		26	8	10	0	1	7	26	26	0

KETERSEDIAAN & DINASAN LOKOMOTIF

SUMATERA UTARA

GAPEKA 2023

NO SERIE LOK	DIPO	KM LOK SEHARI	JUMLAH DINASAN LOKOMOTIF							CAD	KETERSEDIAAN LOK				
			KA Pnp	KA Brng	PLB	Posko/DT	Klb Kerja	Langsir	Jumlah		SO	TSO	SGO	TSGO	SG
BB 203, CC 201	MDN	8.001	8	9	0	0	0	0	17	0	17	1	18	2	20
BB 302/303	MDN	71	0	1	0	0	1	7	9	0	9	1	10	1	11
LOKOMOTIF DE		8.001	8	9	0	0	0	0	17	0	17	1	18	2	20
LOKOMOTIF DH		71	0	1	0	0	1	7	9	0	9	1	10	1	11
JUMLAH		8.072	8	10	0	0	1	7	26	0	26	2	28	3	31

KILOMETER TEMPUH LOK SUMATERA UTARA

GAPEKA TAHUN 2023

NO SERIE LOK	DIPO	KM LOK SEHARI	KILOMETER TEMPUH LOK DALAM BULAN												TAHUN 2022
			JAN	FEB	MAR	APR	MEI	JUN	JUL	AGST	SEPT	OKT	NOP	DES	
CC 201 / BB 203	MDN	8.001	248.022	232.021	248.022	240.021	248.022	240.021	248.022	248.022	240.021	248.022	240.021	248.022	2.928.260
BB 302 / 303	MDN	71	2.212	2.069	2.212	2.140	2.212	2.140	2.212	2.212	2.140	2.212	2.140	2.212	26.110
LOKOMOTIF DE		8.001	248.022	232.021	248.022	240.021	248.022	240.021	248.022	248.022	240.021	248.022	240.021	248.022	2.928.260
LOKOMOTIF DH		71	2.212	2.069	2.212	2.140	2.212	2.140	2.212	2.212	2.140	2.212	2.140	2.212	26.110
JUMLAH DI SUMATERA		8.072	250.234	234.089	250.234	242.162	250.234	242.162	250.234	250.234	242.162	250.234	242.162	250.234	2.954.370



**KANTOR PUSAT
BANDUNG
2023**

KRD
STAMFORMASI
&
KETERSEDIAAN
WILAYAH SUMUT



PT. KERETA API INDONESIA (PERSERO)

DUKUNGAN KRDI, KRDE & RB
GAPEKA TAHUN 2023

DIPO	JENIS		NOMOR SERIE								SG		SF		PERAWATAN		CADANGAN		KETERANGAN
			1	2	3	4	5	6	7	8	JML	TS	JML	TS	JML	TS	JML	TS	
MDN	KDE-RB	K3	3 13 09	3 13 10							2	1	2	1	0	0	0	0	KA Perintis Aceh (BPYBDS)
JUMLAH PEMPROV ACEH											2	1	2	1	0	0	0	0	
RAILINK MDN	KDE 1 AC	K1	2 13 01	2 13 02	2 13 03	2 13 04	2 13 05	2 13 06	2 13 07	2 13 08	8	2	8	2	0	0	0	0	RAILINK MDN - KNO
			2 13 09	2 13 10	2 13 11	2 13 12	2 13 13	2 13 14	2 13 15	2 13 16	8	2	4	1	4	1	0	0	
JUMLAH RAILINK											16	4	12	3	4	1	0	0	
JUMLAH KRDI DI SUMATERA UTARA											18	5	14	4	4	1	0	0	

RANGKAIAN POKOK GAPEKA 2023

DIVRE I MEDAN

NO	NO. KA	NAMA KA	RELASI	JENIS KRD	DEPO	KM TEMPUH	RANGKAIAN POKOK							JUMLAH per HARI				
							KD1	KDE1	KDE3	KDI3	KDE3 AC	KDI3 AC	RB	TS	SF	JUML KA	KAPASITAS	KM KRD
1	U106 / U105 / U108 / U107 / U110 / U109 / U112 / U111	CUT MEUTIA	Bkh - Krg - Kbl	KDI3	MDN	149,80							2	1	2	8	912	300
JUMLAH						Stamformasi	-	-	-	-	-	-	2	1	2			
						Armada	-	-	-	-	-	-	2	1	2	8	912	300
						Cad + TSGO + TSO	-	-	-	-	-	-	-	-	-	-	-	300

NO	NOMOR KA	NAMA KA	RELASI	JENIS KRD	DEPO	KM TEMPUH	RANGKAIAN POKOK							JUMLAH per HARI				
							KD1	KDE1	KDE3	KDI3	KDE3 AC	KDI3 AC	RB	TS	SF	JUML KA	KAPASITAS	KM KRD
1	U2-U1-U8-U7-U14-U13-U20-U19-U26-U25-U32-U31-U38-U37-U44-U43-U50-U49	BANDARA KUALANAMU	Mdn - Knm	KDE1 AC	RAILINK	493,81		4						1	4	18	3.096	1975,248
2	U4-U3-U10-U9-U16-U15-U22-U21-U28-U27-U34-U33-U40-U39-U46-U45	BANDARA KUALANAMU	Mdn - Knm	KDE1 AC		438,94		4						1	4	16	2.752	1755,776
3	U6-U5-U12-U11-U18-U17-U24-U23-U30-U29-U36-U35-U42-U41-U48-U47	BANDARA KUALANAMU	Mdn - Knm	KDE1 AC		438,94		4						1	4	16	2.752	1755,776
JUMLAH						Stamformasi	-	12	-	-	-	-	-	3	12			
						Armada	-	16	-	-	-	-	-	4	16			
						Cad + TSGO + TSO	-	4	-	-	-	-	-	1				

VP TRACTIVE RAIL VEHICLE



SOEGITO
NIPP : 41003

VP TRAIN PASSANGER MARKETING



GOTRO NURYADI
NIPP : 50564

VP TRAIN OPERATION PLANNING



IQBAL T ISKANDAR
NIPP : 44330

The background of the slide is a photograph of a modern train station platform. A white train with red and blue accents is stopped at the platform. The platform has a blue and white striped roof structure. Several people are visible on the platform, some standing and some walking. The overall scene is bright and clean.

KERETA
STAMFORMASI
&
KETERSEDIAAN
(KA PENUMPANG)
WILAYAH SUMUT

KETERSEDIAAN KERETA DAN STAMFORMASI SUMATERA UTARA (MEDAN)

Gapeka 2023

NO	URAIAN	KERETA DI SUMATERA
1	SIAP GUNA	71
2	PERAWATAN	12
3	SIAP OPERASI	59
4	STAMFORMASI	52
5	CADANGAN	7

KERETA SIAP GUNA GAPEKA 2023

DIPO INDUK MEDAN

NO	JENIS KERETA	NOMOR SERIE KERETA																	A	BERAT SIAP	JUMLAH TD
		1	2	3	4	5	6	7	8	9	10	11	12	13	14	15	16	17			
1	K1	0 78 03	0 78 05	0 81 07	0 98 01	0 98 03	0 98 05	0 98 06	0 98 07										8	37	50
2	K2	0 78 46	0 78 48	0 78 54	0 78 64	0 78 61	0 78 65	0 78 66	0 78 69	0 78 72	0 81 05	0 81 06	0 86 08						12	37	64
3	KMP2	0 78 03	0 78 04																2	40	26
4	KP2	0 78 01	0 78 02																2	40	80
5	K3 Split	0 07 34	0 07 35	0 07 36	0 07 37	0 07 38	0 07 39	0 78 07	0 78 09	0 78 11	0 78 19	0 78 20	0 81 01	0 94 10	0 94 11	0 94 12	0 94 13	0 94 14	21	37	106
		0 94 15	0 94 16	0 94 17	0 94 18																
6	K3 prem	0 17 11	0 17 12	0 17 13	0 17 14	0 17 15	0 17 16	0 17 17	0 17 18	0 17 19	0 17 20								10	44	80
7	MP3	0 17 02																	1	40	0
8	KMP3	0 07 04	0 80 01	0 82 04															3	36	48
9	KP3	0 94 04																	1	36	80
10	B	0 82 05	0 82 06	0 82 07	0 82 08	0 82 09	0 82 10	0 85 01											7	36	0
11	P	0 68 05	0 68 06	0 78 05	0 78 08														4	43	0
JUMLAH																		71			

**RANGKAIAN POKOK KA PENUMPANG GAPEKA 2023
DIPO INDUK MEDAN**

NO	NO. KA	NAMA KA	RELASI	JENIS LOK	KM TEMPUH PER KRT	RANGKAIAN POKOK																	JUMLAH PER HARI										
						Lux	K1 Wls	K1 ni	K1	K1 ss	M1	MP1	K2	KMP2	KP2	K3 Split	K3	K3 ni	K3 Prm	K3 ss	KP3	KMP3	MP3	B / BP	P	RANG	KA	SF	TD	KAPASI	TAS TD	KM TEMPUH	
1	U51 / U54 / U56	Sribilah Utama	Rap - Mdn	CC 201	802,83				2					5	1										1			1	3	9	420	1.260	7.225
2	U52 / U53 / U55	Sribilah Utama	Rap - Mdn	CC 201	802,83				2					5	1									1			1	3	9	420	1.260	7.225	
3	U72 / U73 / U76	Puti Deli	Mdn - Tnb	CC 201	523,27											5								1	1		1	3	7	530	1.590	3.663	
	U101F / U102F	Belawan Indah	Mdn - Blw	CC 201	43,21											5										1		1	2	6	530	1.060	259
4	U71	Puti Deli	Tnb - Mdn	BB 203	209,26											5									1	1		1	1	7	530	530	1.465
	U92/U91/U94/U93/U96/U95/U98/97/U100/U99	Sri Lelawangsa	Mdn - bji - Kbg	BB 203	167,11											5										1	10	6	530	5.300	1.003		
5	74/U75	Puti Deli	Mdn - Tnb	BB 203	418,52											5								1		1		1	2	7	530	1.060	2.930
	U82/U81/U84/U83/U86/U85/U88/U87/U90/U89	Sri Lelawangsa	Mdn -Bij-Mdn-Kbg	BB 203	167,11											5										1	10	6	530	5.300	1.003		
6	U77 / U78	Siantar Ekspres	Sir - Mdn	CC 201	516,04												3									1		1	2	4	318	636	2.064
	U79F / U80F	Siantar Ekspres	Sir - Mdn	CC 201	516,04												3									1		1	2	4	318	636	2.064
	U103F / U104F	Belawan Indah	Mdn - Blw	CC 201	43,21												3									1		1	2	4	318	636	173
7	U62F / U61F / U64F / U63F / U66F / U65F	Amir Hamzah	Bsg - Bij	BB 203	470,40																						1	6	5	320	1.920	2.352	
8	U68F / U67F / U70F / U69F	Datuk Belambangan	Tbi - Lag	BB 203	142,42																							1	4	4	240	960	570
JUMLAH		Stamformasi				-	-	-	4	-	-	-	10	2	-	18	-	-	7	-	1	2	1	5	2	9	50	56	840	2.520	14.451		
		Siap Guna				-	-	-	8		-	-	12	2	2	21	-	-	10	-	1	3	1	7	4			71	4.694	19.628	17.545		
		Perawatan				-	-	-	1	-	-	-	2	-	1	3	-	-	2	-	-	1	-	1	1				12				
		Cadangan				-	-	-	3	-	-	-	-	-	1	-	-	-	-	1	-	-	-	-	1	1			7	5.534	22.148	31.996	

Catatan :

Vice President Passenger Marketing



GOTRO NURYADI
NIPP : 50564

Vice President Coaches and Wagons



BUDI HERJANTO
NIPP : 40966

VP TRAIN OPERATION PLANNING



IQBAL T ISKANDAR
Nipp : 44330

KETERSEDIAAN KERETA SUMATERA UTARA TAHUN 2023

NO	JENIS KERETA	POSISI KETERSEDIAAN				
		SIAP GUNA	PERAWATAN	SO	SF	CADANGAN
1	Luxury					
2	K1 Wisata					
3	K1 ni					
4	K1	8	1	7	4	3
5	K1 ss					
6	K/M1					
7	MP1					
8	K2	12	2	10	10	0
9	KMP2	2	0	2	2	0
10	KP2	2	1	1	0	1
11	MP2					
12	K3 Split	21	3	18	18	0
13	K3					
14	K3 ni					
15	K3 Prem	10	2	8	7	1
16	K3 ss					
17	MP3	1	0	1	1	0
18	KMP3	3	1	2	2	0
19	KP3	1	0	1	1	
20	P	4	1	3	2	1
21	B / BP	7	1	6	5	1
TOTAL		71	12	59	52	7



**KANTOR PUSAT
BANDUNG
2023**

**GERBONG
STAMFORMASI
&
KETERSEDIAAN
(KA BARANG)
SUMUT**



KETERSEDIAAN GERBONG DAN STAMFORMASI SUMATERA UTARA (DIVRE I MEDAN)

GAPEKA TAHUN 2023

NO	URAIAN	DIVRE I
1	SIAP GUNA	305
2	PERAWATAN	46
3	SIAP OPERASI	259
3	STAMFORMASI	226
4	CADANGAN	33

GERBONG SIAP GUNA GAPEKA 2023
SUMATERA UTARA (DIVRE I MEDAN)

KLASIFIKASI	JENIS	NOMOR GERBONG										JUMLAH	BERAT	
		1	2	3	4	5	6	7	8	9	10			
BM 30 T	GK-KKW 30 TON (INKA) CPO	30 84 64	30 84 67	30 84 69	30 84 72	30 84 73	30 84 74	30 84 75	30 84 78	30 84 80	30 84 81	10	18	
		30 84 82	30 84 83	30 84 86	30 84 88	30 84 90	30 84 91	30 84 92	30 84 93	30 84 94	30 84 95	10		
		30 84 96	30 84 99	30 84 103	30 84 105	30 84 109	30 84 110	30 84 112	30 84 115	30 84 116	30 84 117	10		
		30 84 118	30 84 123	30 84 124	30 84 126	30 84 127	30 84 128	30 84 130	30 84 131	30 84 132	30 84 140	10		
		30 84 141	30 84 145	30 84 148	30 84 150	30 84 152	30 84 155	30 84 157	30 84 161	30 84 162	30 84 164	10		
		30 84 165	30 84 166	30 84 170	30 84 173	30 84 174	30 84 175	30 84 179	30 84 181	30 84 182	30 84 186	10		
		30 84 187	30 84 188	30 84 190	30 84 192	30 84 193	30 84 194	30 84 196	30 84 197	30 84 199	30 84 200	10		
		30 84 201	30 84 202	30 84 204	30 84 205	30 84 207	30 84 208	30 84 210	30 84 212	30 84 213	30 84 214	10		
		30 84 222	30 84 223	30 84 225	30 84 228	30 84 229	30 84 230	30 84 232	30 84 235	30 84 236	30 84 238	10		
		30 84 240	30 84 241	30 84 242	30 84 244	30 84 245	30 84 246	30 84 249	30 84 250	30 84 251	30 84 254	10		
		30 84 255	30 84 256	30 84 274	30 84 275	30 84 276	30 84 277	30 84 278	30 84 279	30 84 280	30 84 282	10		
		30 84 283	30 84 284	30 84 285	30 84 286	30 84 287	30 84 288	30 84 289	30 84 290	30 84 292	30 84 293	10		
		30 84 309										1		
		JUMLAH GK CPO												121
		30 84 68	30 84 108	30 84 133	30 84 134	30 84 135	30 84 136	30 84 138	30 84 139	30 84 142	30 84 143	10		
	30 84 146	30 84 149	30 84 151	30 84 153	30 84 154	30 84 156	30 84 158	30 84 167	30 84 169	30 84 176	10			
	30 84 177	30 84 206	30 84 216	30 84 217	30 84 218	30 84 224	30 84 239	30 84 248			8			
	JUMLAH GK CPO SMART											28		
	30 84 97	30 84 104	30 84 119	30 84 129	30 84 172	30 84 178	30 84 183	30 84 198			8			
	JUMLAH GK CPO LATEX											8		
	30 84 147										1			
	JUMLAH GK TIMBANGAN											1		
	JUMLAH GK CPO											158		
	GK-KKW 30 TON (PERTAMINA) BBM	30 84 71	30 84 114	30 84 171	30 84 195	30 84 209	30 84 221	30 84 233	30 84 234	30 84 252	30 84 257	10		
		30 84 295	30 84 296	30 84 297	30 84 298	30 84 299	30 84 300	30 84 301	30 84 302	30 84 303	30 84 304	10		
		30 84 305	30 84 306	30 84 307	30 84 308	30 84 311	30 84 312	30 84 313	30 84 315	30 84 316	30 84 317	10		
		30 84 318	30 84 319	30 84 320	30 84 321	30 84 322	30 84 323	30 84 324	30 84 325	30 84 326	30 84 327	10		
		30 84 328	30 84 329	30 84 330	30 84 331	30 84 332	30 84 333	30 84 334	30 84 335			8		
		JUMLAH GK PERTAMINA												48
	JUMLAH GK - KKW 30 TON											206		
GB-KKBW 30 T	30 65 50	30 66 73	30 65 80	30 65 110	30 65 138	30 65 171	30 65 178	30 65 194	30 65 201	30 65 285	10	17		
	30 65 283	30 66 27	30 66 46	30 66 53	30 66 56						5			
	JUMLAH												15	

KLASIFIKASI	JENIS	NOMOR GERBONG										JUMLAH	BERAT	
		1	2	3	4	5	6	7	8	9	10			
BM 30 T	GD-PPCW 30 TON	30 84 92	30 84 97	30 84 110	30 84 119								4	
		JUMLAH										4		
BM 42 T	GD-PPCW 42 TON	42 11 302	42 11 303	42 11 305	42 11 307	42 11 308	42 11 311	42 11 313	42 11 317	42 11 321	42 11 323	10	15	
		42 11 325	42 11 329	42 11 334	42 11 335	42 11 336	42 11 337	42 11 340	42 11 341	42 11 344	42 11 346	10		
		42 11 347	42 11 348	42 11 351	42 11 353	42 11 356	42 11 357	42 11 359	42 11 360	42 11 361	42 11 362	10		
		42 11 363	42 11 364	42 11 365	42 11 366	42 11 372	42 11 375	42 11 376	42 11 378	42 11 379	42 11 380	10		
		42 11 383	42 11 384	42 11 386	42 11 388	42 11 389	42 11 392	42 11 396	42 11 398	42 11 400	42 12 01	10		
		42 12 09	42 12 20	42 12 23	42 12 30	42 12 34	42 12 35	42 12 39	42 12 40	42 12 41	42 12 43	10		
		42 12 45	42 12 48	42 12 52	42 12 53	42 12 59	42 12 60	42 12 62	42 12 63	42 12 64	42 12 65	10		
		42 12 71	42 12 73	42 12 75	42 12 77	42 12 79	42 12 80	42 12 82	42 12 83	42 12 85	42 12 90	10		
		JUMLAH										80		
JUMLAH GERBONG DIVRE I MEDAN											305			

REKAP POSISI GERBONG GAPEKA 2023
SUMATERA UTARA (DIVRE I MEDAN)

NO	KELOMPOK & JENIS		KETERSEDIAAN				
			SIAP GUNA	PERAWATAN	SIAP OPERASI	STAMFORMASI	CADANGAN
DIVRE I MEDAN							
1	GD	PPCW 30 T	4	1	3	0	3
2		PPCW 40 T					
3		PPCW 42 T	80	12	68	63	5
4		PKPKW 45 T					
5		PPCW 50 T					
6		PPCW 54 T (INKA)					
7		PPCW 54 T (Cina)					
8	GB	KKBW 25 T					
9		KKBW 30 T	15	2	13	0	13
10		KKBW 30 T Batubara					
11		KKBW 45 T Batubara					
12		KKBW 50 T Batubara (Canada)					
13		KKBW 50 T Batubara (INKA)					
14		KKBW 50 T Batubara (China)					
15		ZZOW 30 T					
16		ZZOW 50 T					
17	GK	KKW 30 T	206	31	175	163	12
18		KKW 40 T					
19	GT	GGW 30 T					
20		ZZOW 50 T					
JUMLAH PT KAI			305	46	259	226	33

**ARMADA GERBONG DINAS UNTUK PRASARANA SUMUT
KEBUTUHAN PRASARANA TAHUN 2023**

NO	KELOMPOK & JENIS		DIPO INDUK MDN
1	GD	GD - PPCW 30T	4
2		GD - PPCW 40T	
3		GD - PPCW 42T	
4		GD - PKPKW 45T	
5		GD - PPCW 50T	
6	GB	GB - KKBW 25T	
7		GB - KKBW 30T	15
8		GB - ZZOW 30T	
9		GB - ZZOW 50T	
10	GT	GT - ZZOW 50T	
JUMLAH			19