

**Principal Items Delivered to Armed Forces During World War II From 1941 to 1946**

**By Camillus Cutlery Co.**

<u>Item Numbers</u>	<u>Description</u>	<u>Quantity</u>
5677 L99 ; 5682 L75 ; 5683 L75 ; 5683 L94; 5684 L77 ; 5684 Q3 ;5685 Q39	Fighting & Utility Bayonets	1,955,024
5369 L67B	Fish Knives	247,380
14 F31 ; 14 L23 ; 14 QZ ; 14 Q38 ; 14 S13 ; 14 S26	Navy 4 blade Knives	2,564,220
14 F31 ; 14 L55	Army or Engr. Knives	3,282,988
425 L21 ; 425 L39 ; 5541 J51	Sailor's Knives	698,020
14 L79 ; 14 J95A ; 14 J95S ; 5665 L66 ; 5679 L36	Air Corps Knives	1,042,040
57 L49 ; S7 A73 ; 54 J94	Signal C. Elec. Knives	2,183,136
5541 L29 ; 5541 L34 ; 5541 L46	Navy Jack Knives	1,711,012
5674 L12 ; 5674 L45 ; 5675 L13; 5676 L14 ; 5680 L60 ; 5671 L61	Surgical Knives	196,593
14 S11 ; 14 S25 ; 14 L68 ; 14 L69;	Quartermaster Knives	855,472
7085 J72	Spike Knife	38,148
5678 L35	Machetes	<u>121,848</u>
	<b>Total</b>	<b><u>14,895,881</u></b>

1/10/62

NAVY DEPARTMENT

Navy Knife #5541 L 46  
5541L 29

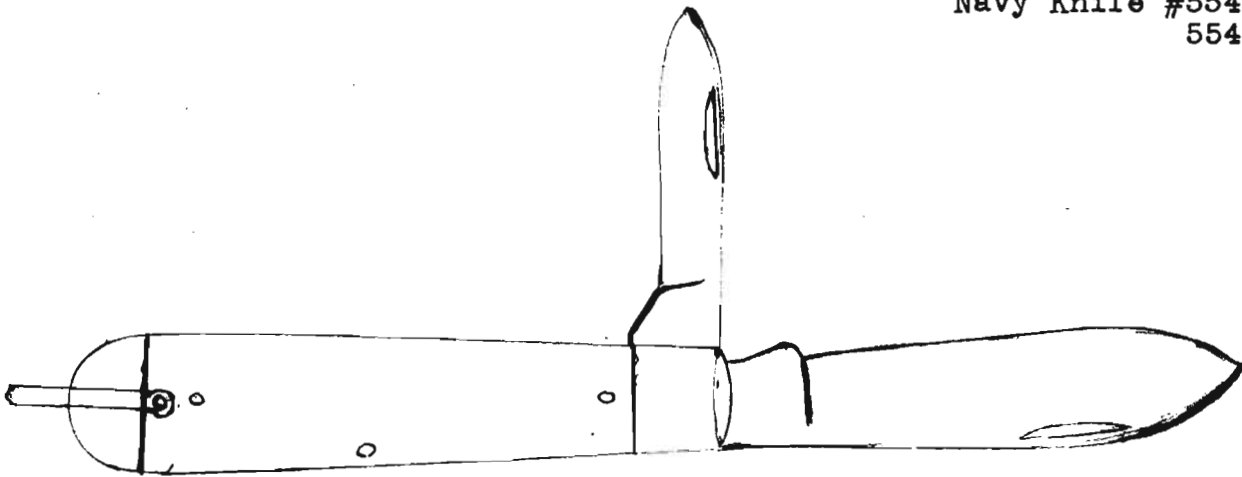

5541 L 34 L 46  
5541 L 31  
5541 L 46 - L 46  
S 3999

DESCRIPTION:

Original number S-3999, Specifications 41J4  
Made with n/s bolster, brass lining and n.s shackle, no shield

#5541J51 brass lining and n/s bolster, n/s shackle, no shield,  
sold in February 1942 under this number.

5541L46 - all steel - no shield, SFBA, linings, center and  
springs to be zinc plated before assembly. Sold in August  
1942 under this number.

5541L29 - same as 5541L46 except we received permission from  
the Navy Dept. to aluminum paint the springs, instead of zinc  
plating.

SPECIFICATIONS:

41J4b of 6/29/42 9/1/42

OTHER MANUFACTURERS:

Imperial, Ulster, Utica, Pal

CONTRACTS:

Sold in 1940 - 243,000  
1941 - 108,000

1942- 906,000  
1943 - 443,200 to date  
1944 - 1,800 - 1/24 CCC  
" ~~57,000 - 2/24~~ ?

12/30/43

ARMY AIR FORCES

Hunting Knife - 5" w/sheath

Govt #  
Our # 5665 L 66

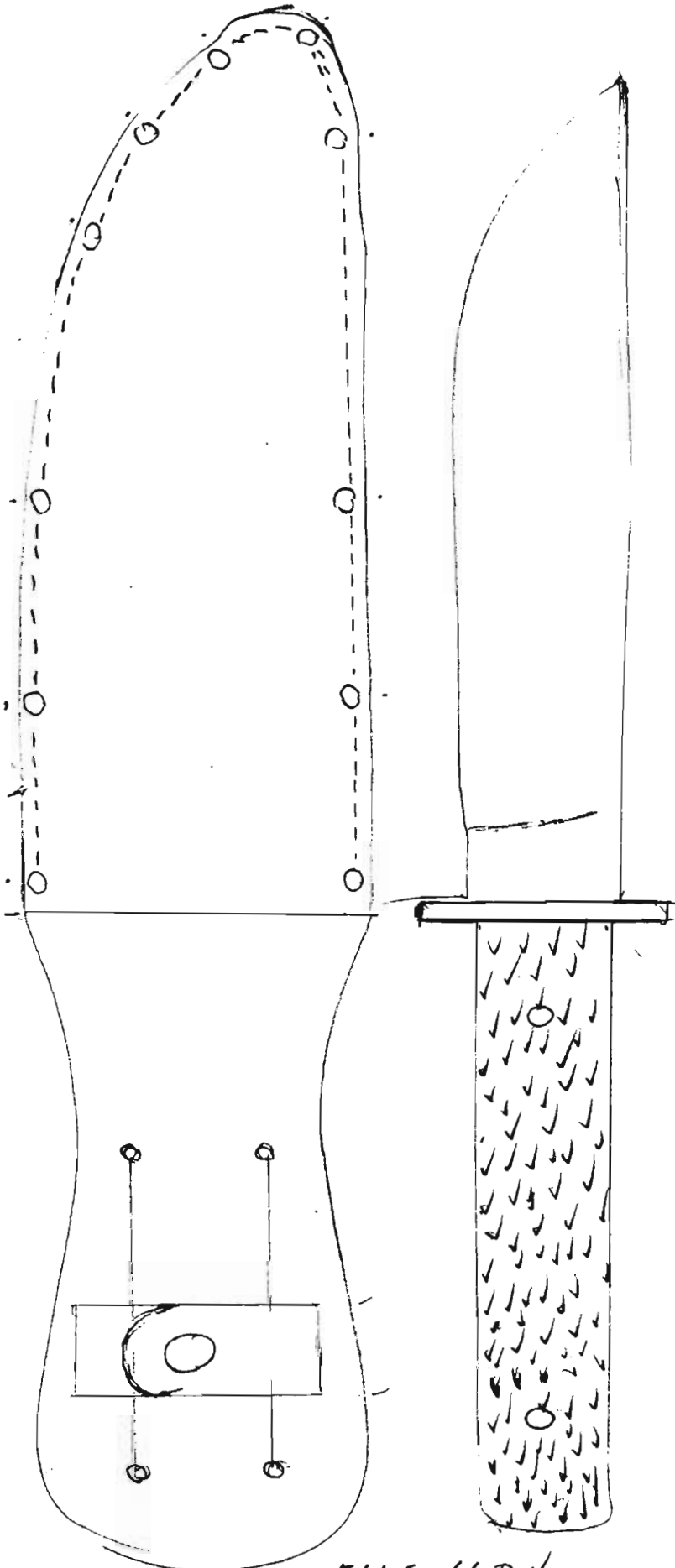

DESCRIPTION

5" polished blade, ~~staged~~ rosewood handle, steel guard, Mosser sheath - also with bone handle.

SPECIFICATIONS

none

CHANGES

handle

OTHER MANUFACTURERS:

none

USES

Emergency kits

CONTRACTS

sub-contracted through Liberty Electric Co. Camillus: 35,500

5665 L 66 RW

OTF:JL

ALSO

5665 L 66 BONA

12/30/43

U.S. ARMY ENGINEERS CORPS

Hunting Knife - 5" w/sheath

Govt #

Our # 5665 J 86

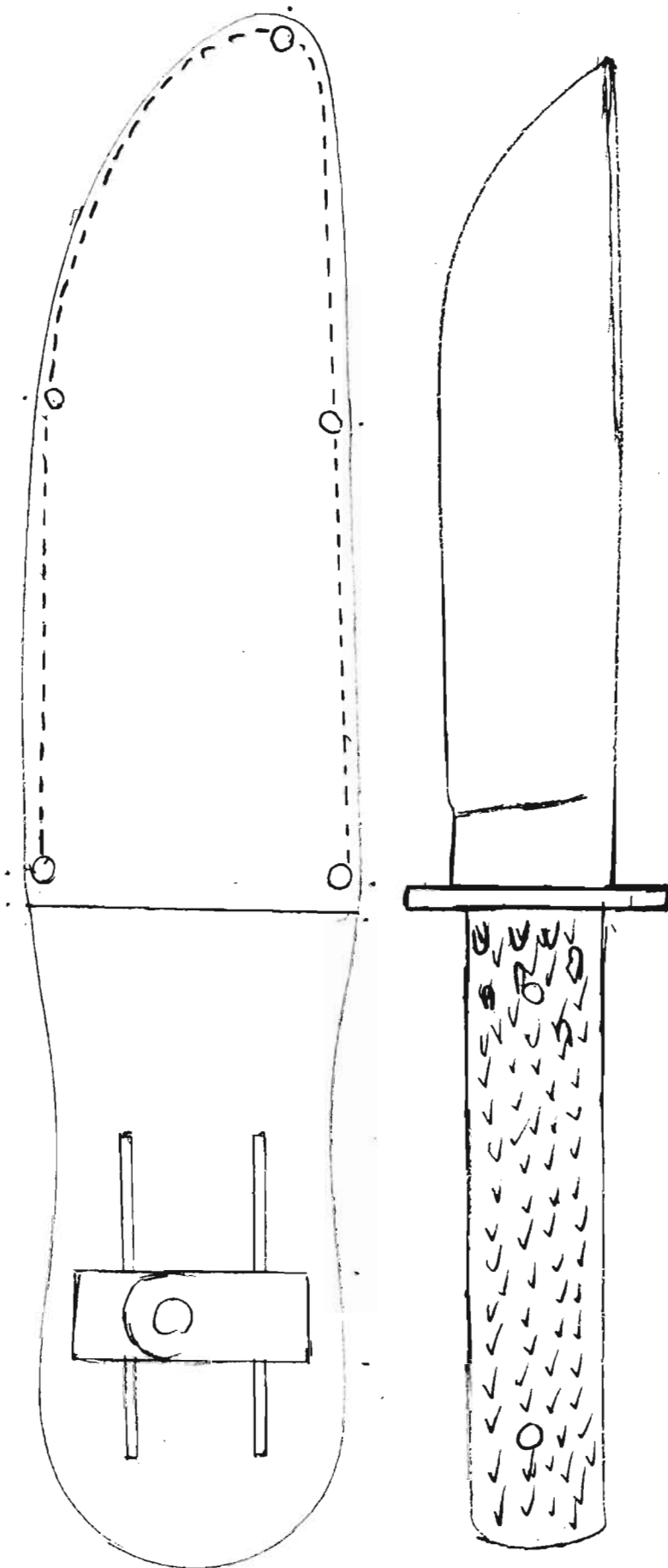

DESCRIPTION

5" polished blade, with stagged rosewood handle.

Sheath from Atlantic Mfg. Co. K153

SPECIFICATIONS

none

CHANGES

OTHER MANUFACTURERS

Utica Cutlery Co.

CONTRACTS

Camillus: 828 only

5665 J 86 RW

CTF:JL

Ena.

Govt #

Our # 5665 - with leather sheath

HUNTING KNIFE

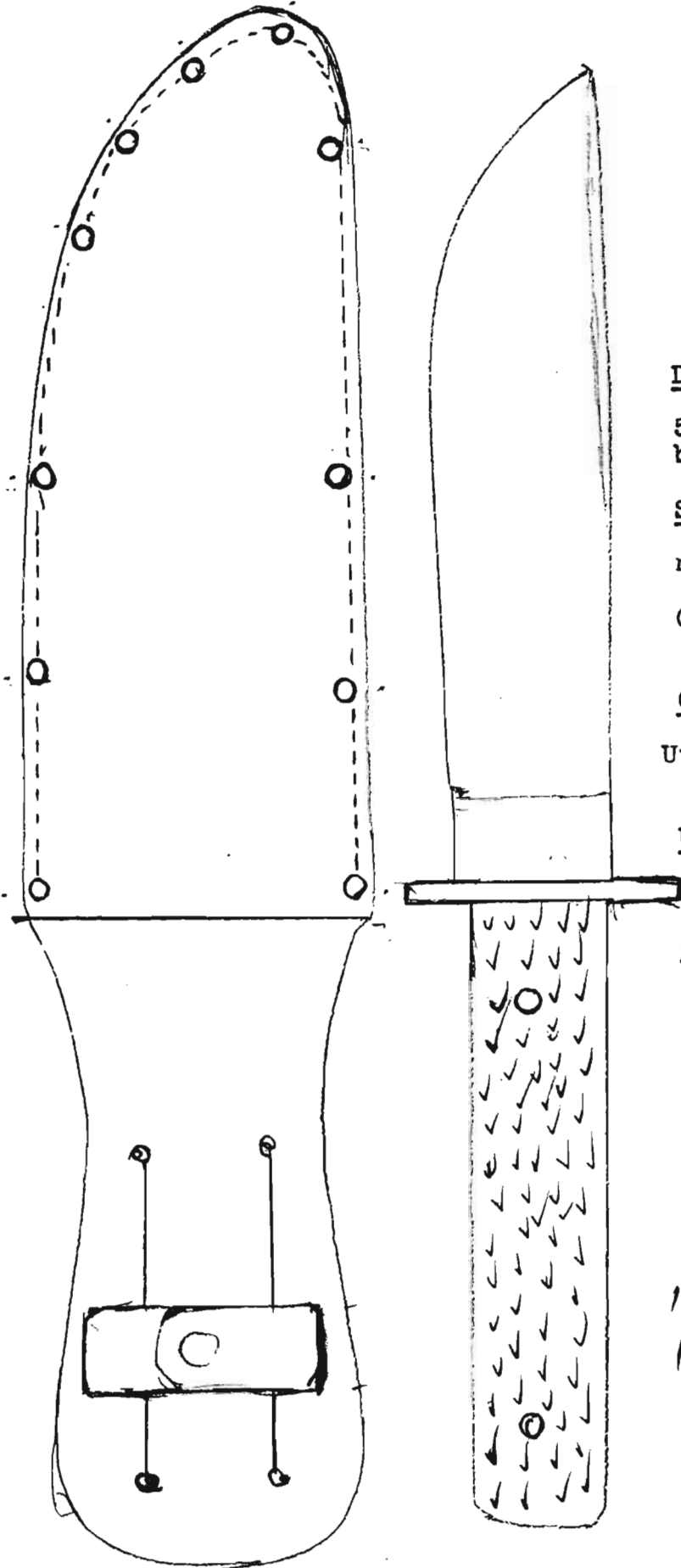

DESCRIPTION

5" blade, Hunting Knife, steel bolsters, bone handle

SPECIFICATIONS

none

CHANGES

OTHER MANUFACTURERS

Utica Cutlery Co.

USES

CONTRACTS

Camillus: 1,000;

CAMILLUS

1942 1000

SUB-Govt 5"

1942	- 7,452
1943	36,792
1944	72
1945	1

5665 MARINE CORPS

ON ORDER 9858

19/30/43

ARMY AIR FORCES

Govt. #  
Our # 5679 L 36 - Hunting  
Knife with Mosser Sheath

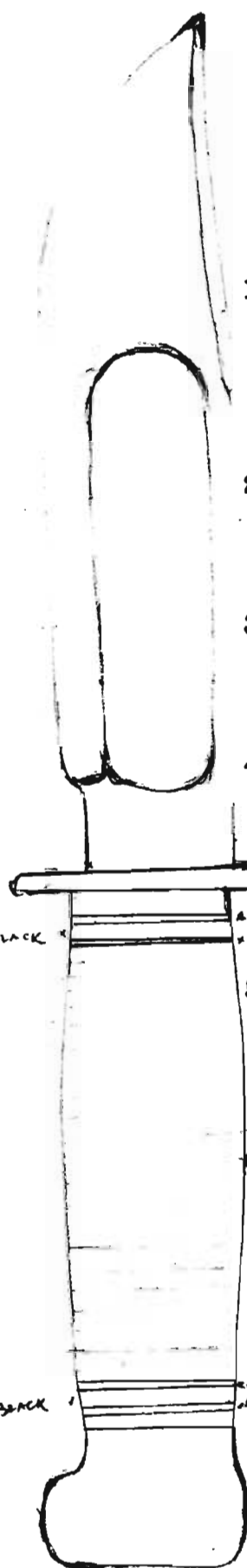
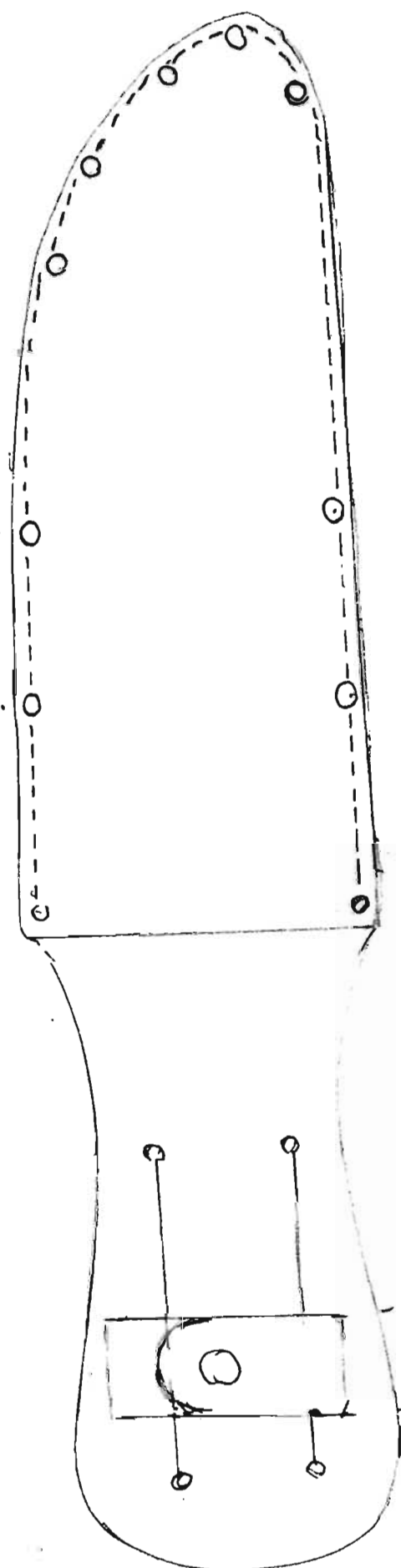

1. DESCRIPTION

5" glazed blade Hunting Knife,  
brass guard, aluminum butt,  
leather washer handle.

2. SPECIFICATIONS

none

3. CHANGES

none

4. OTHER MANUFACTURERS

Marble Arms Mfg. Co., Western  
States, Cattaraugus, Kinsfolk

5. USES

Used in all types of emergency  
kits.

6. CONTRACTS

Camillus - 75,000

4 others - 257,000 total

1942 Camillus 75,000 ea.

5679 L 36 5" HUNTING  
AIR CORPS

10/27/43

AIR CORPS KNIFE

Our No. S-6018

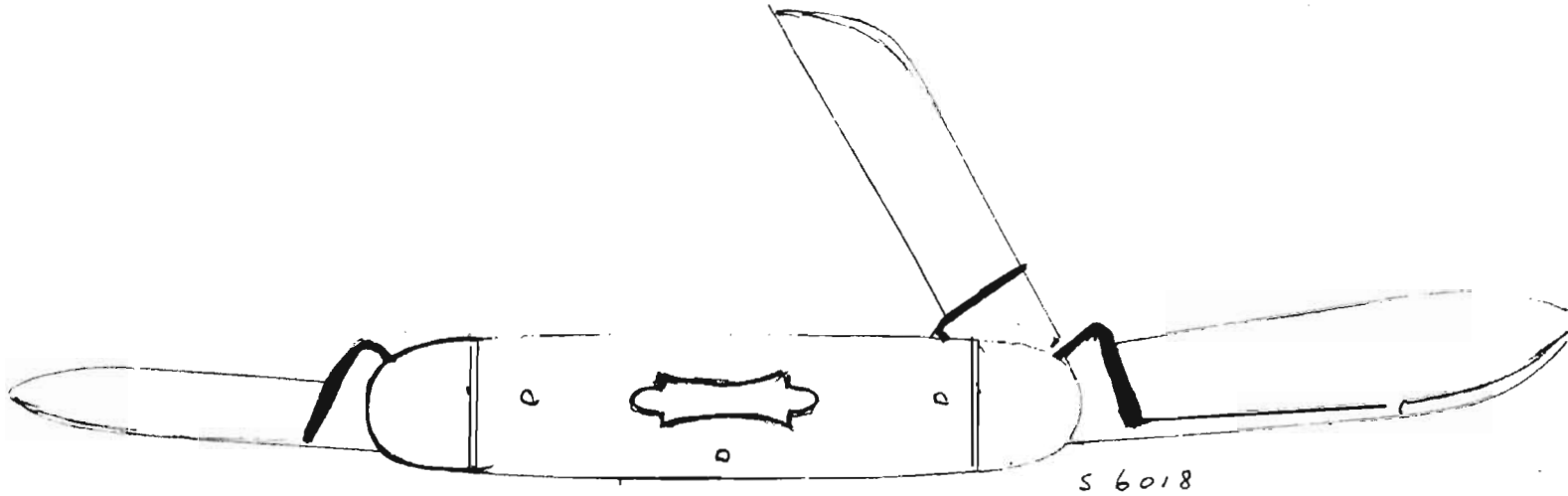

See page on 14J95C for description. Original knife made with shield, brass linings, n/s bolster.

12/27/43

AIR CORPS KNIFE

Govt. No.

Our No. 14J95C  
14J95A

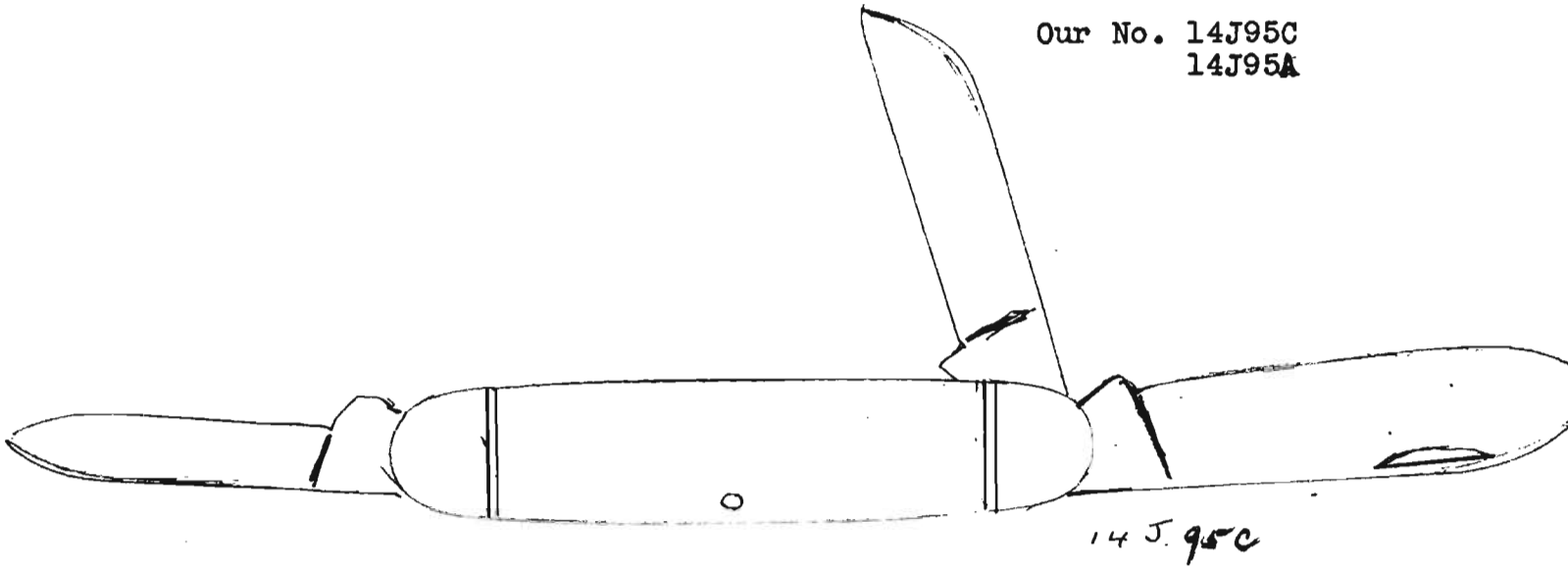

Purchased only by the Air Corps

DESCRIPTION: Original knife, our S6018 - see drawing on next page  
S6018 bone stag, 14 pattern, 3-5/8" spear, sheepfoot and pen, n/s shield, painted springs, brass lining, n/s bolster.

First change made on order placed 12/11/41: steel bolsters and linings, n/s shield, SFAA.

14J95C - 4/25/42 - changed to FG molded stag, no shield, all iron and springs finished before assembly.

14J95A - for use in life rafts. Constructed exactly like the 14J95C but with clevice.

SPECIFICATIONS

OTHER MANUFACTURERS

Imperial, Pal, W.R. Case, Union, Utica, Schrade, Ulster, Cattaraugus

USES - Utility

CONTRACTS - CCC.

1940	Camillus -	29,450 ea.
1941	"	40,000
1942	"	775,767
1943	"	15,000

CONTRACTS - OTHERS

Imperial 1942 540,000 ea.



BREAD KNIFE

12/30/43

U.S. ARMY QUARTERMASTER

BREAD KNIFE, 10" blade

Govt Stock #64-K-515

Our # 5669 J 60

DESCRIPTION

10" Bread Knife, brass rivets, beechwood handle

SPECIFICATIONS

Q.M. #43, type 4, table 4

CHANGES

OTHER MANUFACTURERS

CONTRACTS

Camillus: 11,396

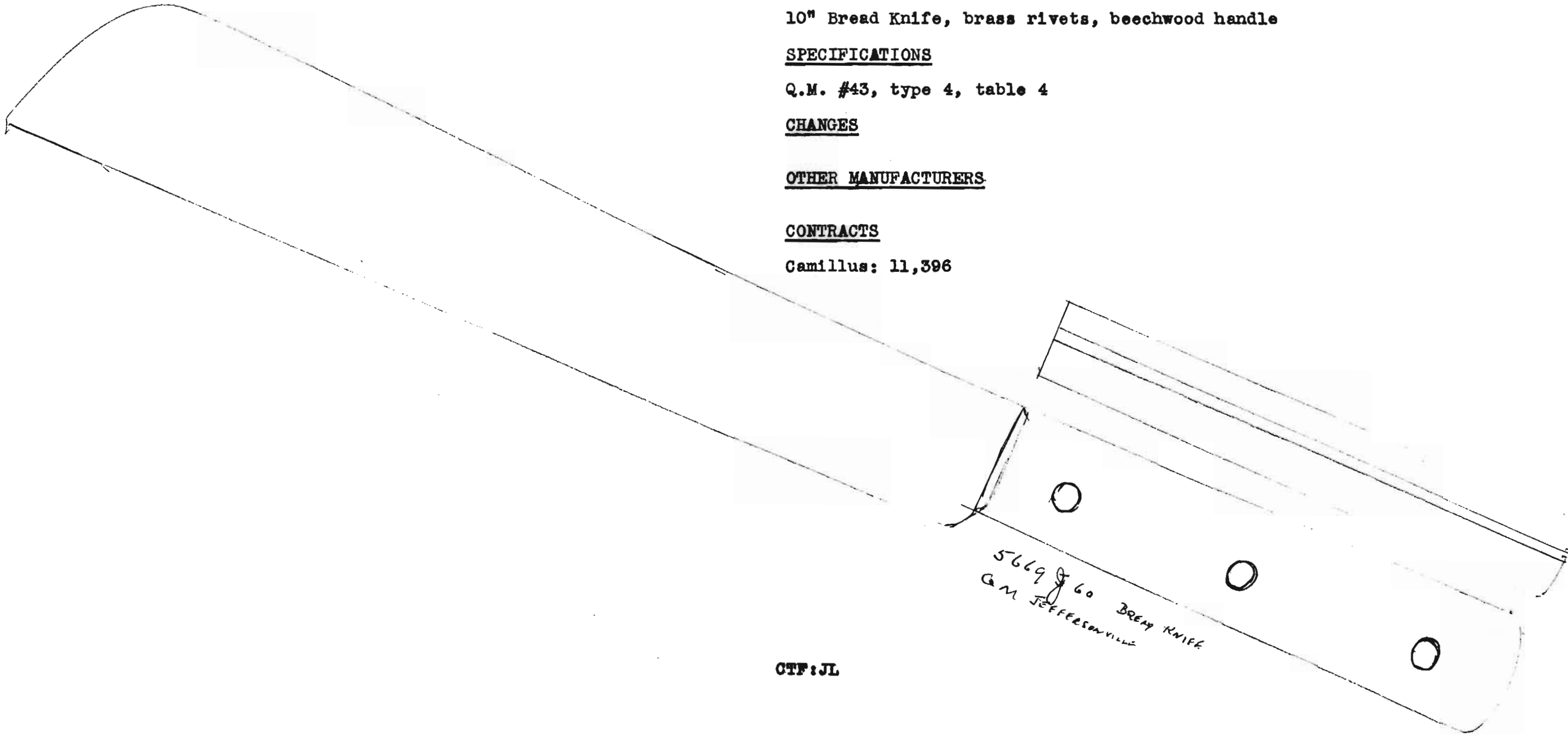

5669 J 60 BREAD KNIFE  
G M JEFFERSONVILLE

CTF:JL

Our #5669L44  
Their type 2, 10" blade

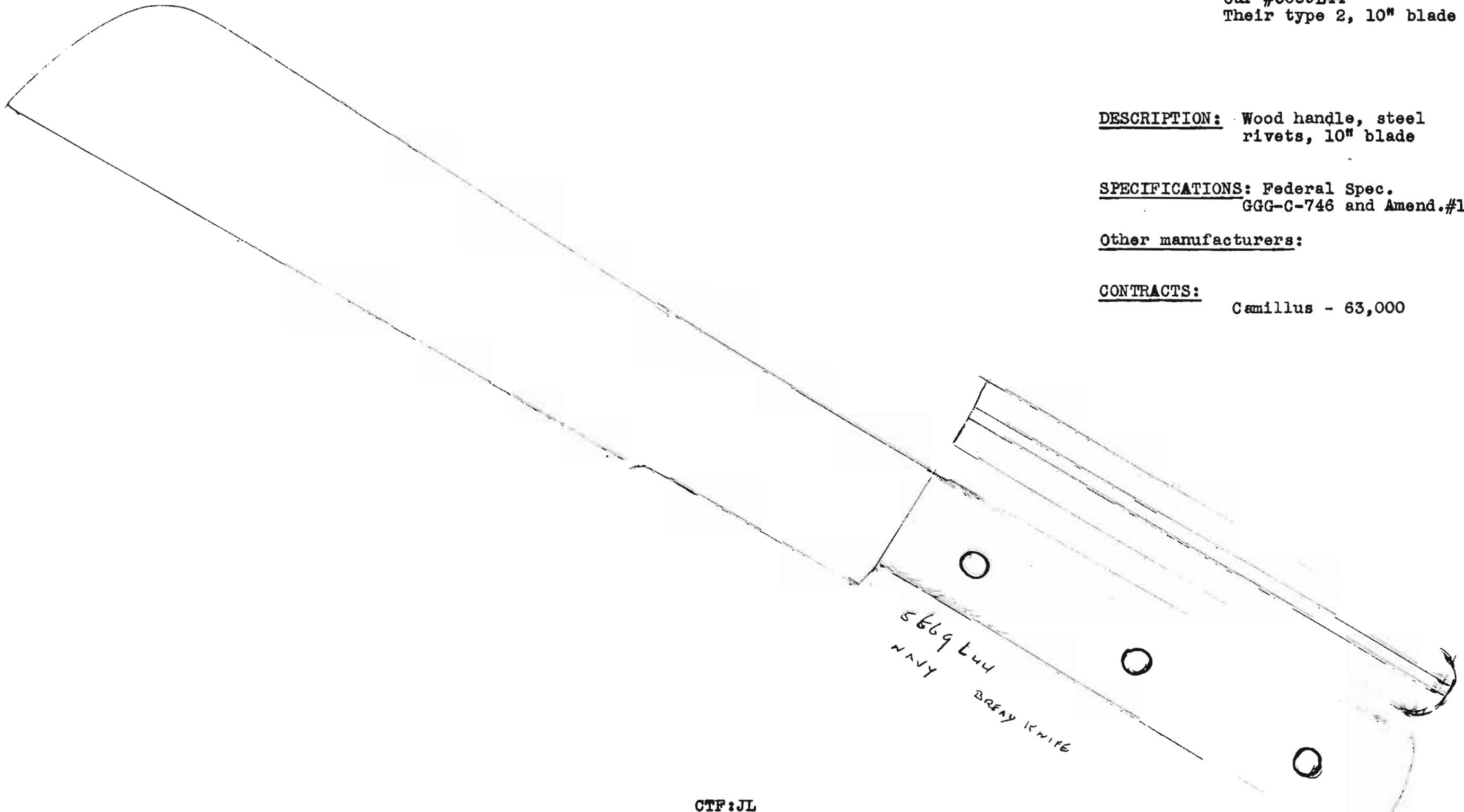

DESCRIPTION: Wood handle, steel rivets, 10" blade

SPECIFICATIONS: Federal Spec. GGG-C-746 and Amend.#1

Other manufacturers:

CONTRACTS: Camillus - 63,000

10" Butcher Knife

12/30/43

F  
U.S. ARMY QUARTERMASTER

BUTCHER KNIFE - 10"

Govt Stock# 64-K-545

Our # 5670 J 61

DESCRIPTION

10" blade, no bolster, brass rivets, beechwood handle

SPECIFICATIONS

Type 5, table 5, figure 5, Spec. #43.

CHANGES

OTHER MANUFACTURERS

Lamson, Goodnow, Russel Harrington, Clyde Cutlery, Ontario Cutlery

CONTRACTS

Camillus: 22792; 5736;

Others:

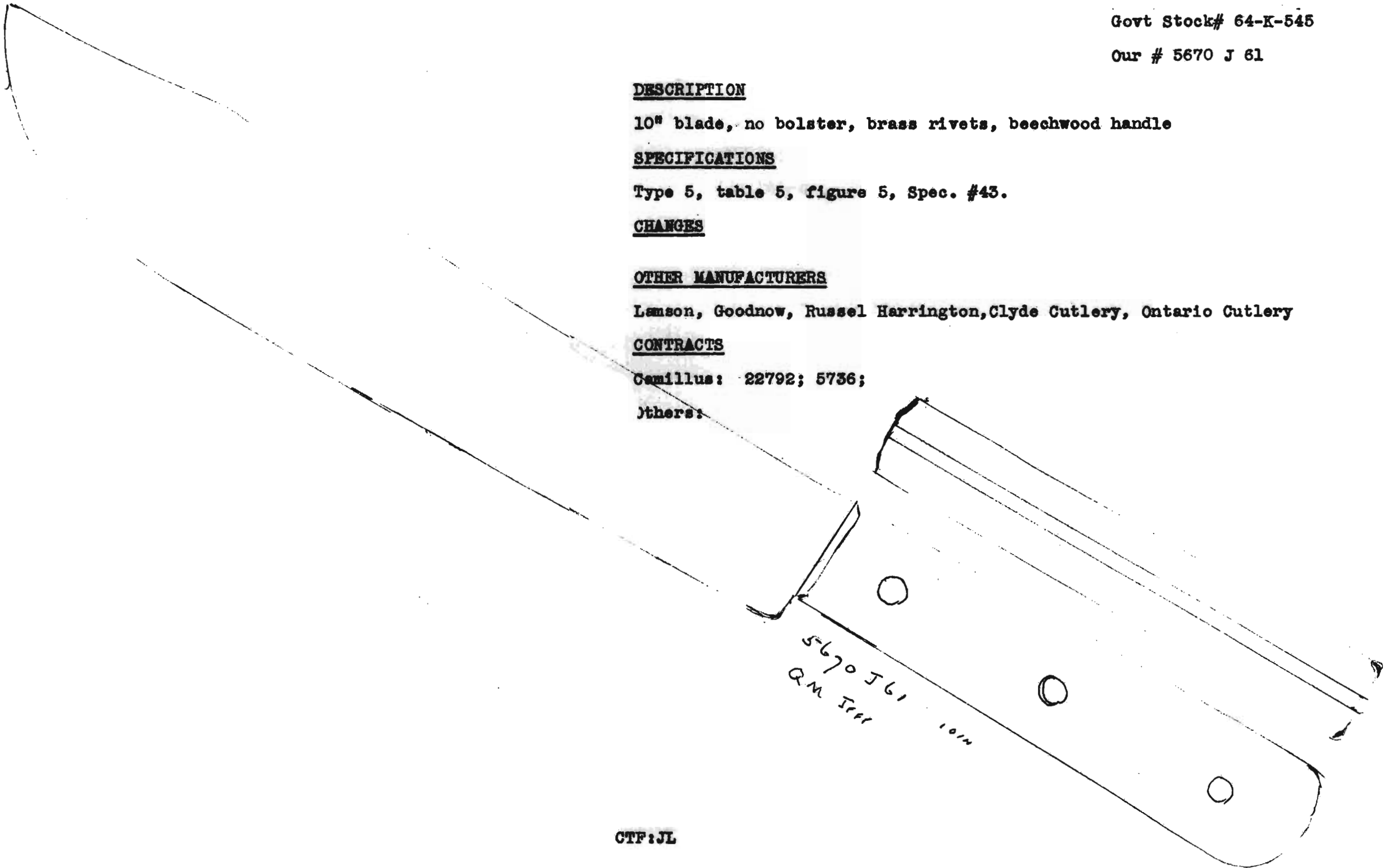

CTF:JL

Butcher Knife 10"

1/5/44

Navy Department

13.

BUTCHER KNIFE - 10"

Our 5670 L8  
Their Lot 59, grade A, type V

DESCRIPTION: 10" blade, wood handle,  
brass rivets, no bolster

SPECIFICATIONS: GGG-C-746, Amend #1  
(Federal)

CONTRACTS: - Camillus-26,000 only

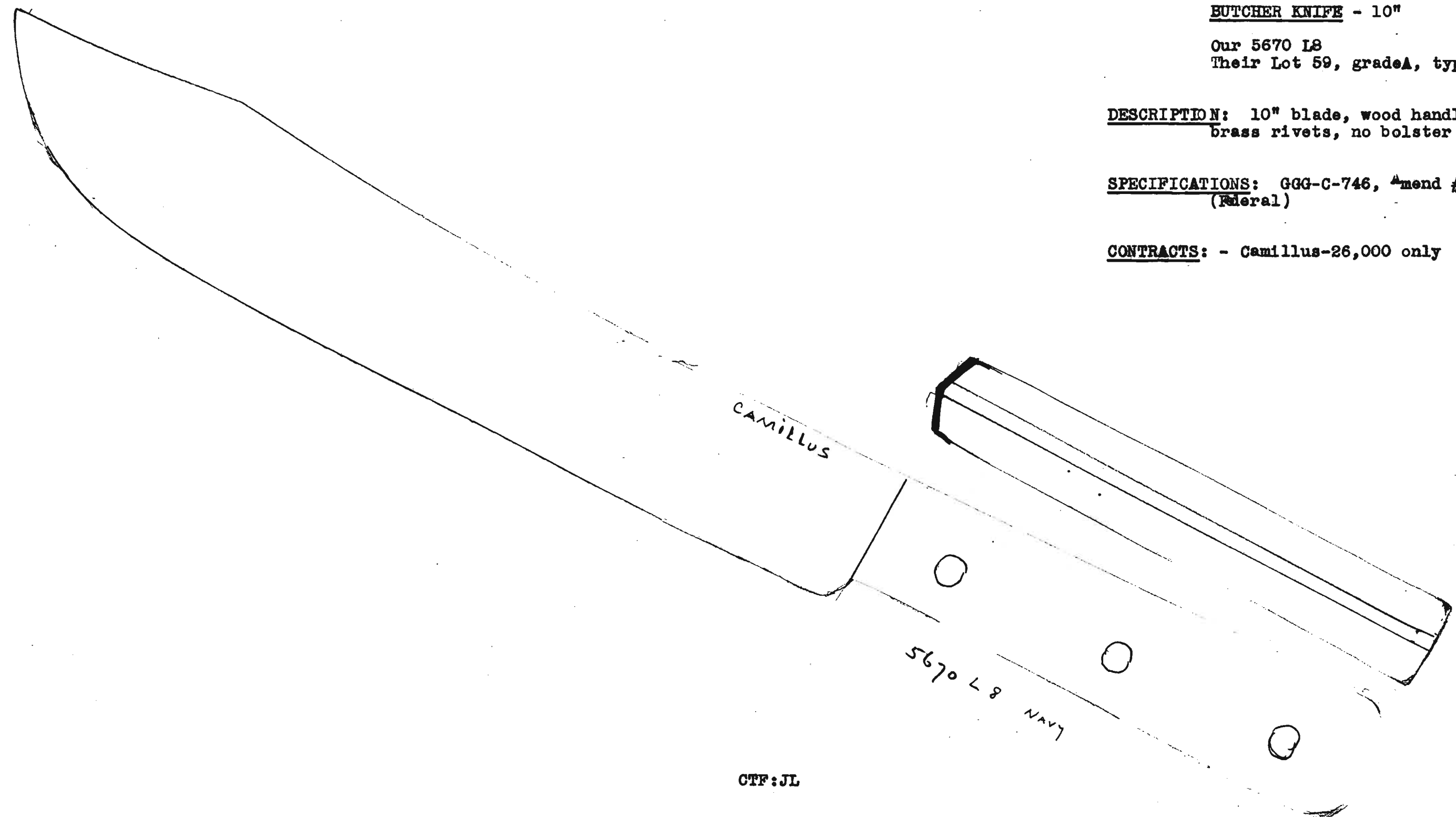

GTF:JL

10" Butcher Knife

12/30/43

U.S. ARMY QUARTERMASTER <sup>2</sup>

GOVT # Stock 64K550-65

Our # 5670 L 38

BUTCHER KNIFE - 10"

DESCRIPTION

10" blade Butcher Knife with metal bolster, beechwood handle,  
3 brass rivets.

SPECIFICATIONS

U.S. Army 28-119

CHANGES: 9/9/42 - revised to steel rivets

OTHER MANUFACTURERS

Lamson, Goodnow, Russel Harrington, Clyde Cutlery, Ontario Cutlery,

CONTRACTS:

Camillus - 11,760

Others -

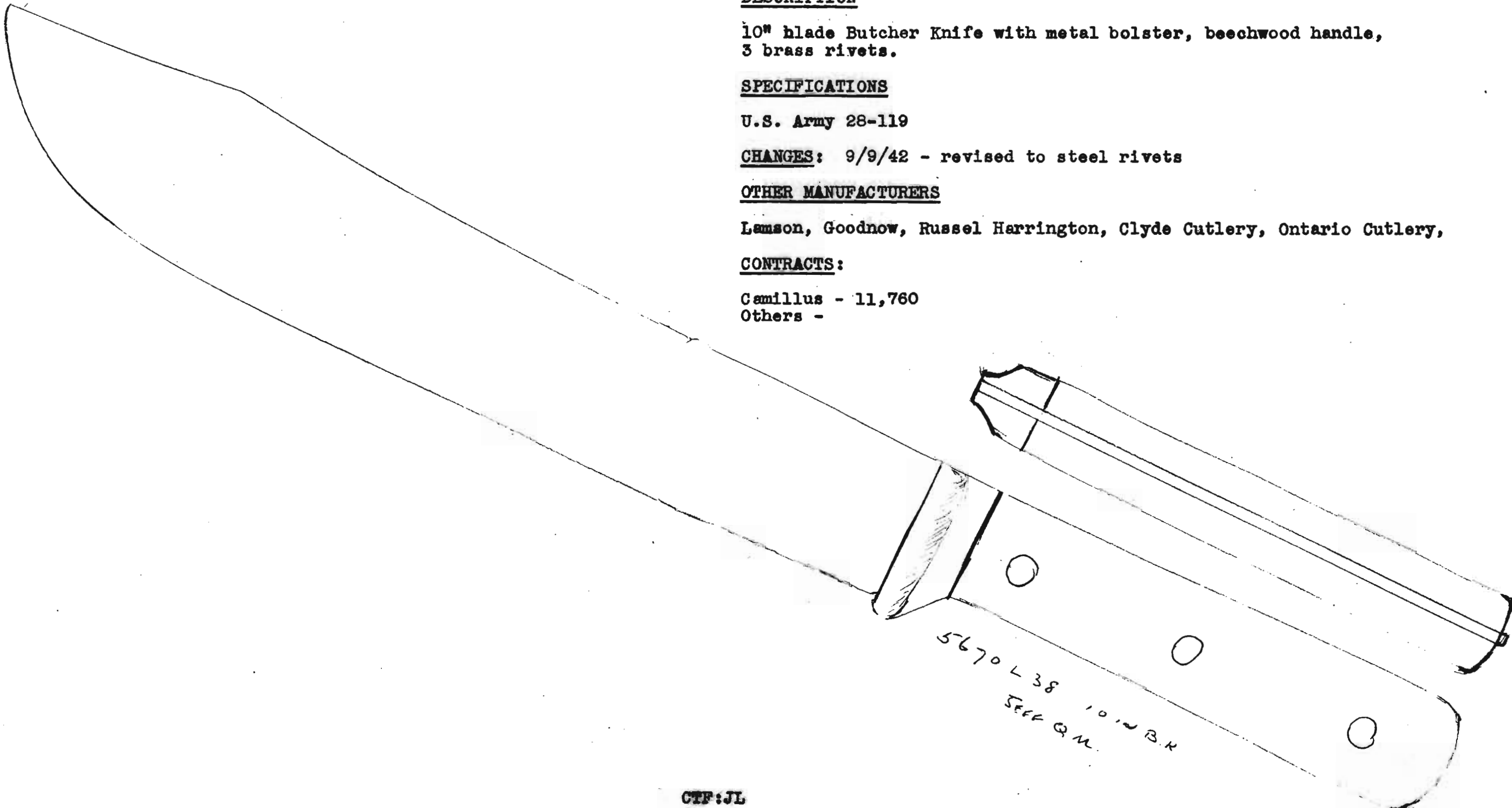

CTF:JL

10/27/43

CAMP TYPE KNIFE

U.S. NAVY

Bureau of Medicine and Surgery

Gov't No. - Stock 6-125  
Our No. - Like 14F31 and 14L23, bone stag  
14Q2 -all steel

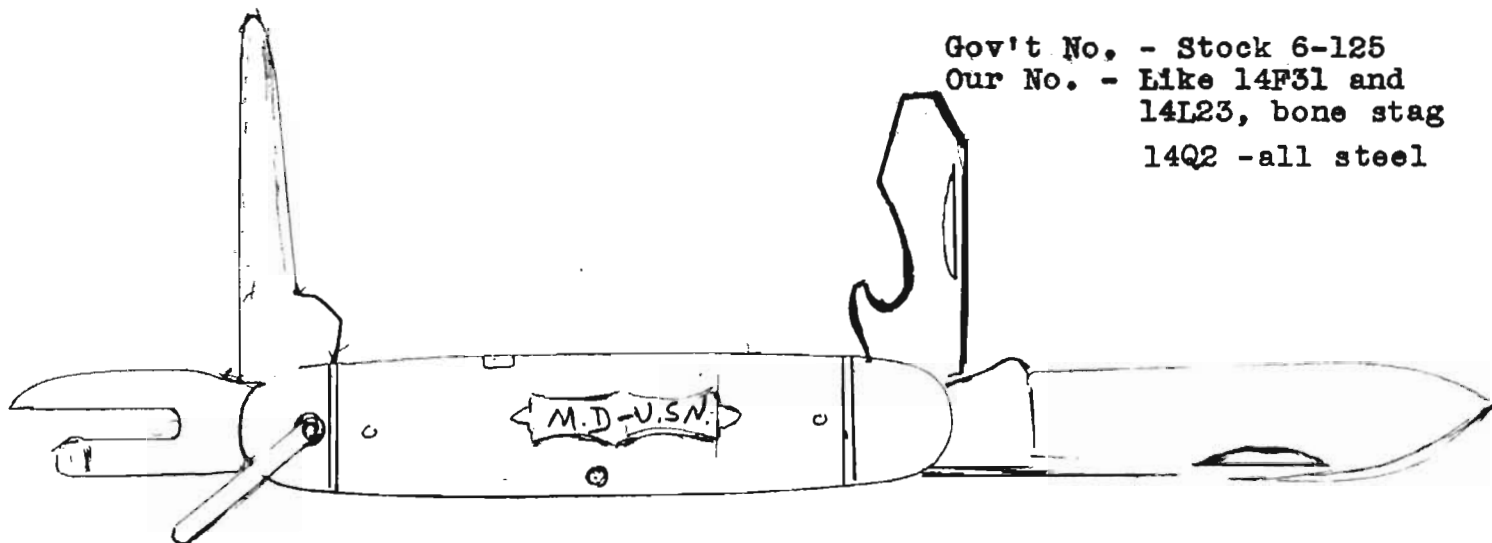

1. DESCRIPTION

- a) Cost Book Sheet S-33, 5/27.42  
Like 14F31 bone stag, 14/4 scout, spear, 978 C.O; 14 S.D; punch, 23 shield stamped MD-USN; brass and n/s, 5 tang 8 inside; round haft, n/s clevice.
- b) Like 14L23 bone stag, Cost book sheet S-29 of 5/7/42  
Like above but all steel with n/s clevice.
- c) 14Q2 - all steel, bone stag

2. SPECIFICATIONS

Bureau of Medicine and Surgery, Jackknife "Boy Scout" type, Spec. #1-J-001a (INT) 4/1/41, 4 blade (see description above) All blades forged, carbon content 1.0-1.1%, Rockwell C scale 56-61, center lining brass or steel. Marking MD-USN on shield or cutting blade. No shield required. See Spec. 41-J-4 of 9/1/42 all steel, w/shield

A. CHANGES -

#1 - Spec. 41-J-001b (INT) of 9/10/42, primarily clarification of previous specifications with minor changes in packing and inspection.

#1a - Same specification but all steel with n/s blade rivets.

#1b - 3/26/43 - same specs but all steel. (Change made on an Imperial contract)

Our changes 14L23 - all steel but n/s blade rivets and n/s shackle described above.

3. OTHER MANUFACTURERS

Schrade Cutlery

Utica Cutlery

Imperial

Russell-Harrington

JL

4. CONTRACTS

				<u>Total</u>
1942-3	Camillus - 3 contracts	3600 - 14,400 - 14,400		32,400

Imperial (had portion of their contract of April 1943 rejected due to two piece can opener being defective.

1944 - Camillus

33,600

14,400

10/27/43

U.S. ARMY

ENGINEERS KNIFE

No. 14F31  
14L55

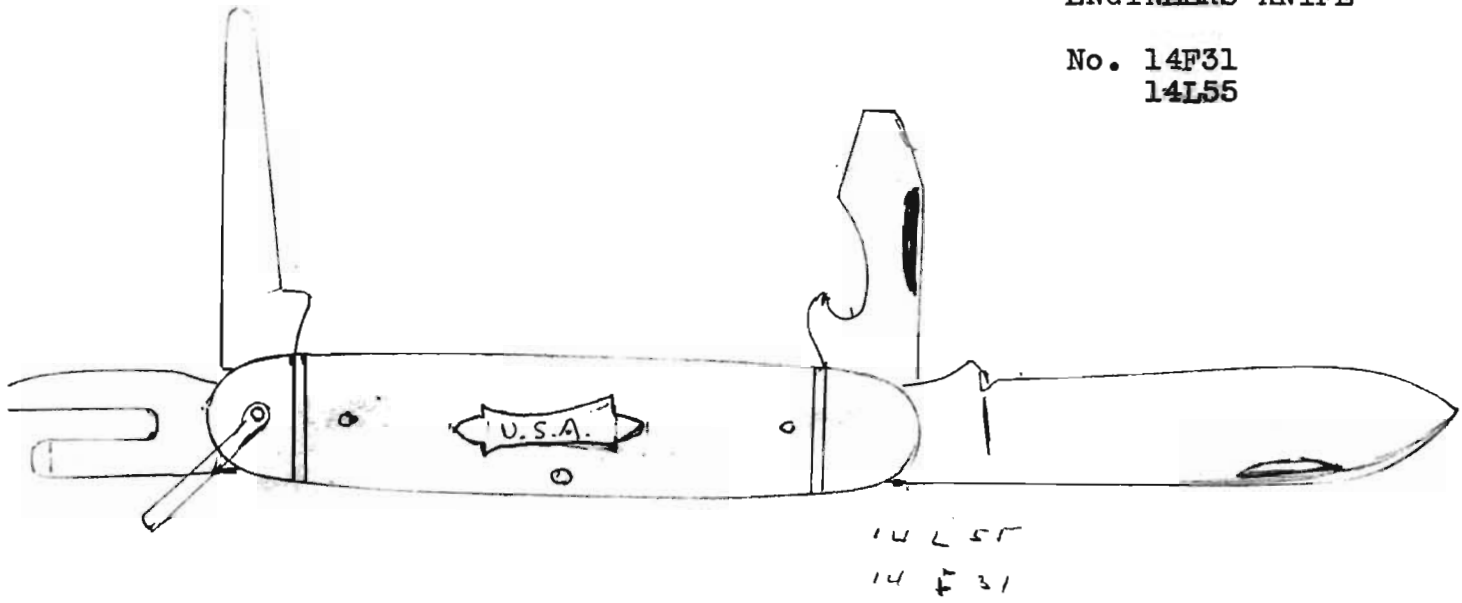

DESCRIPTION:

4 blade with clevice

14F31 - first made with brass lining and n/s bolster for Engineers in 1940.

In 1942 we made some of the knives with steel linings, steel bolsters and brass center scale. Also made with U.S.M.C. on shield for the Marines.

14L55 - first order placed 10/5/42 - made all steel. No new specifications issued, although they were suggested. Shield stamped U.S.A.

SPECIFICATIONS: U.S. Army Engineers 17-170

OTHER MANUFACTURERS:

Imperial, Cattaraugus, Ulster, Utica, Case, Pal, Queen City, Aerial Cutlery Kinfolks, Inc.

CONTRACTS:	1940 - 57,882	1942 - 1,112,652
	1941 - 83,384	1943 - 1,722,820 to 11/13
		941,790
		1944 745,044
		1945 32,000

sub-government contracts

HKZ: JL

SUB-GOVT:	1942	53,900
	1943	30,468

10/27/43

LIFE RAFT FISHING KIT KNIFE

U.S. NAVY  
Bureau of Aeronautics

Gov't No.  
Our No. - 5369 L 67B

(Reference: A.A.F. Life Raft  
Fishing Kit Knife)

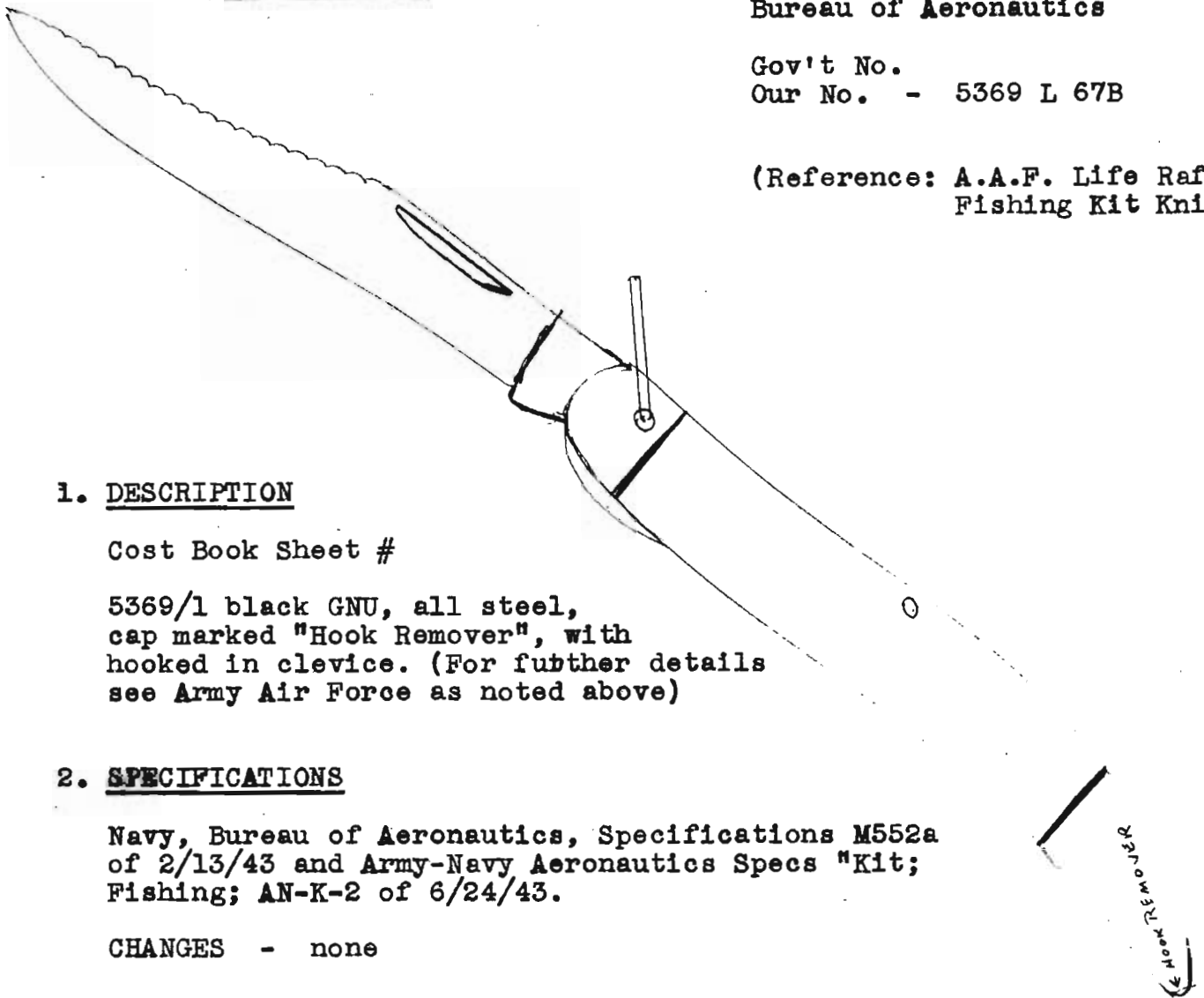

1. DESCRIPTION

Cost Book Sheet #

5369/1 black GNU, all steel,  
cap marked "Hook Remover", with  
hooked in clevice. (For fubther details  
see Army Air Force as noted above)

2. SPECIFICATIONS

Navy, Bureau of Aeronautics, Specifications M552a  
of 2/13/43 and Army-Navy Aeronautics Specs "Kit;  
Fishing; AN-K-2 of 6/24/43.

CHANGES - none

3. OTHER MANUFACTURERS

none

4. USES

For emergency landings at sea in connection with equipment  
contained in Fishing Kits. Lanyard attached to knife to prevent  
its being lost overboard.

5. CONTRACTS

Ashaway Line & Twine Co. (1943)



10/30/43

ARMY AIR FORCES

FISH KNIFE

Govt #  
Our # 5369 L 67b

REFERENCE: Navy Bureau of  
Aeronautics

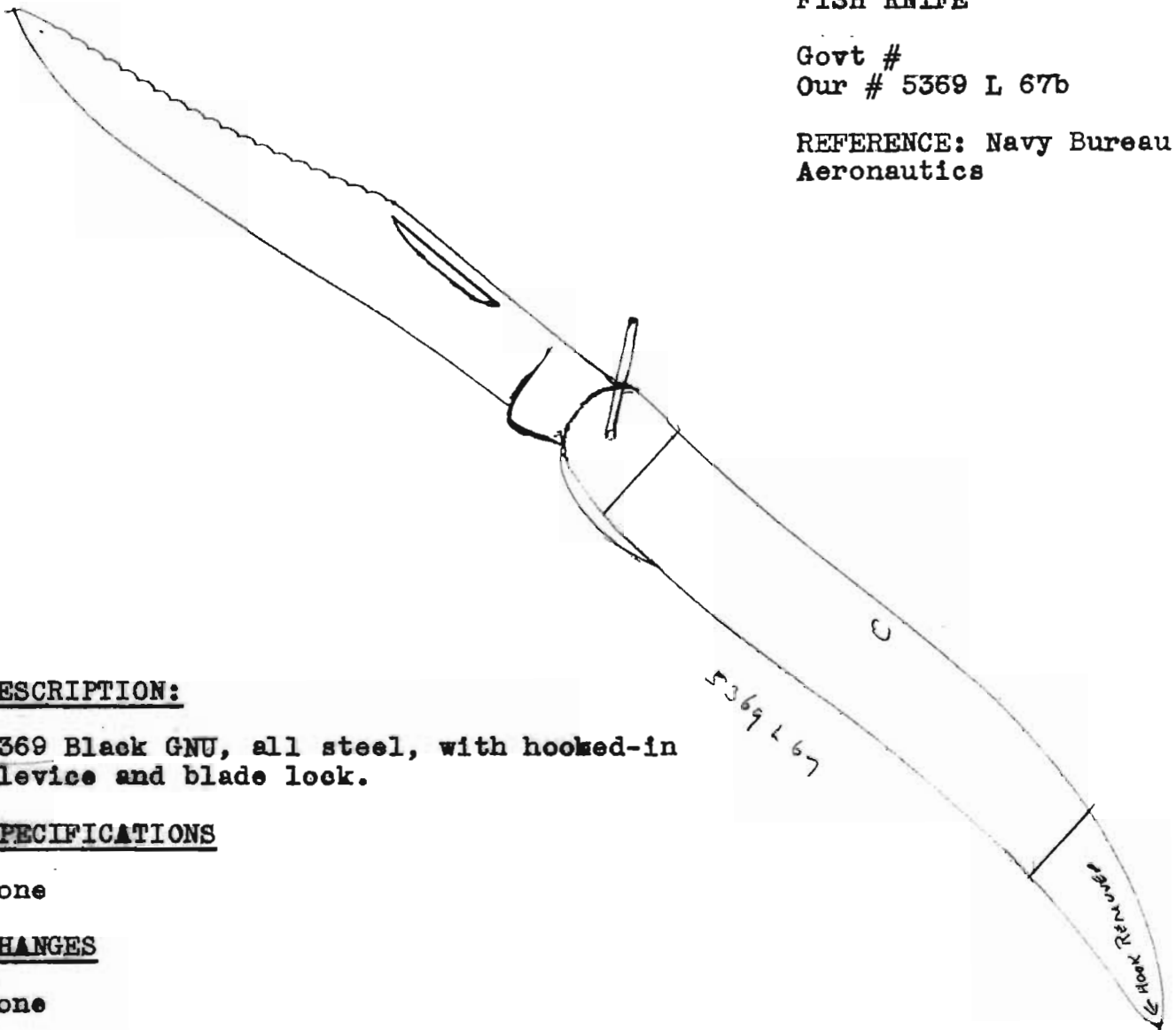

DESCRIPTION:

5369 Black GNU, all steel, with hooked-in clevice and blade lock.

SPECIFICATIONS

none

CHANGES

none

OTHER MANUFACTURERS

none

USES

In fishing kits which are included in life rafts for emergency uses at sea.

CONTRACTS

No prime contracts - subcontracts: ~~Henrietta Johnson 40,000~~  
~~Sports Products 66,000, 15,000;~~

↓

1943 -	167,41 ✓
1944	15,067
1945	14,808

19/30/43

U.S. ARMY  
ROCHESTER ORDNANCE DISTRICT

Govt No. M3  
Our No. 5682 L 75

With scabbards furnished by  
the Government. M6  
\* (Changed to M8 plastic)

**DESCRIPTION** - 6-3/4", Parkerized, double edge blade, steel guard,  
steel butt, leather handle

**SPECIFICATIONS** - Drawing # 20-2B-52 dated 12/30/42

**CHANGES** - revised drawing with minor radius changes 11/13/43

**OTHER MANUFACTURERS:** Imperial, Utica, W.R. Case, Kinsfolk, Pal,  
Aerial Cutlery, Robeson

**USES** - Utility knife used by certain ground forces of the AAF,  
Tank Units and specialised Commando units.

**CONTRACTS** - Camillus: 35,900; 113,000; 117,000;  
137,009; *total 402,909*

Others: Received approximately 1,500,000

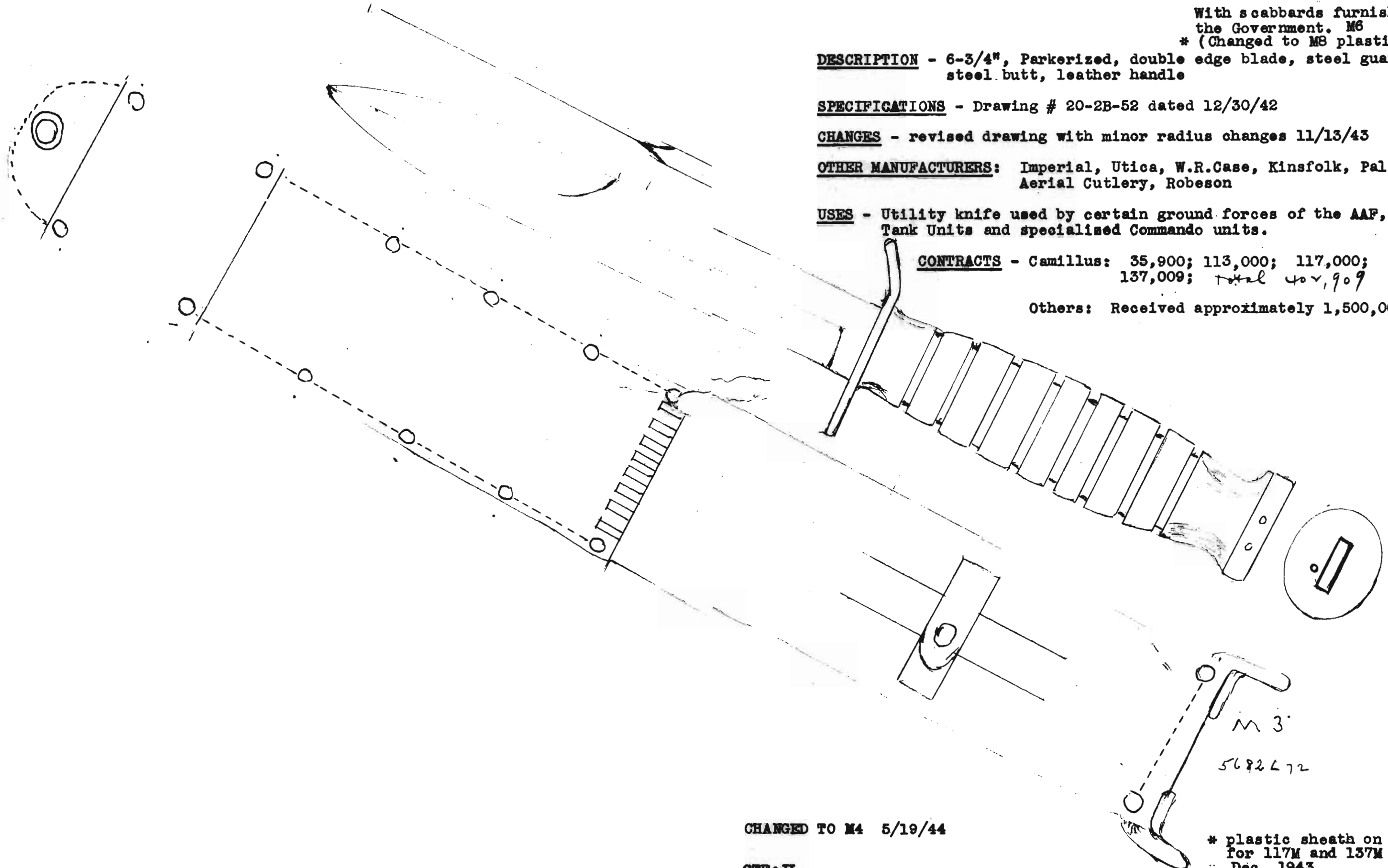

M 3  
5682 L 72

CHANGED TO M4 5/19/44

CTF:JL

\* plastic sheath on contracts  
for 117M and 137M  
- Dec. 1943

5/19/44

~~ARMY ORDNANCE~~

M4 Knife, Bayonet

Our 5685Q39

( W/sheath same as M3 )

DESCRIPTION: Bayonet for carbine rifle  
with plastic sheath M8

SPECIFICATIONS: Tentative Specs AXS 1278

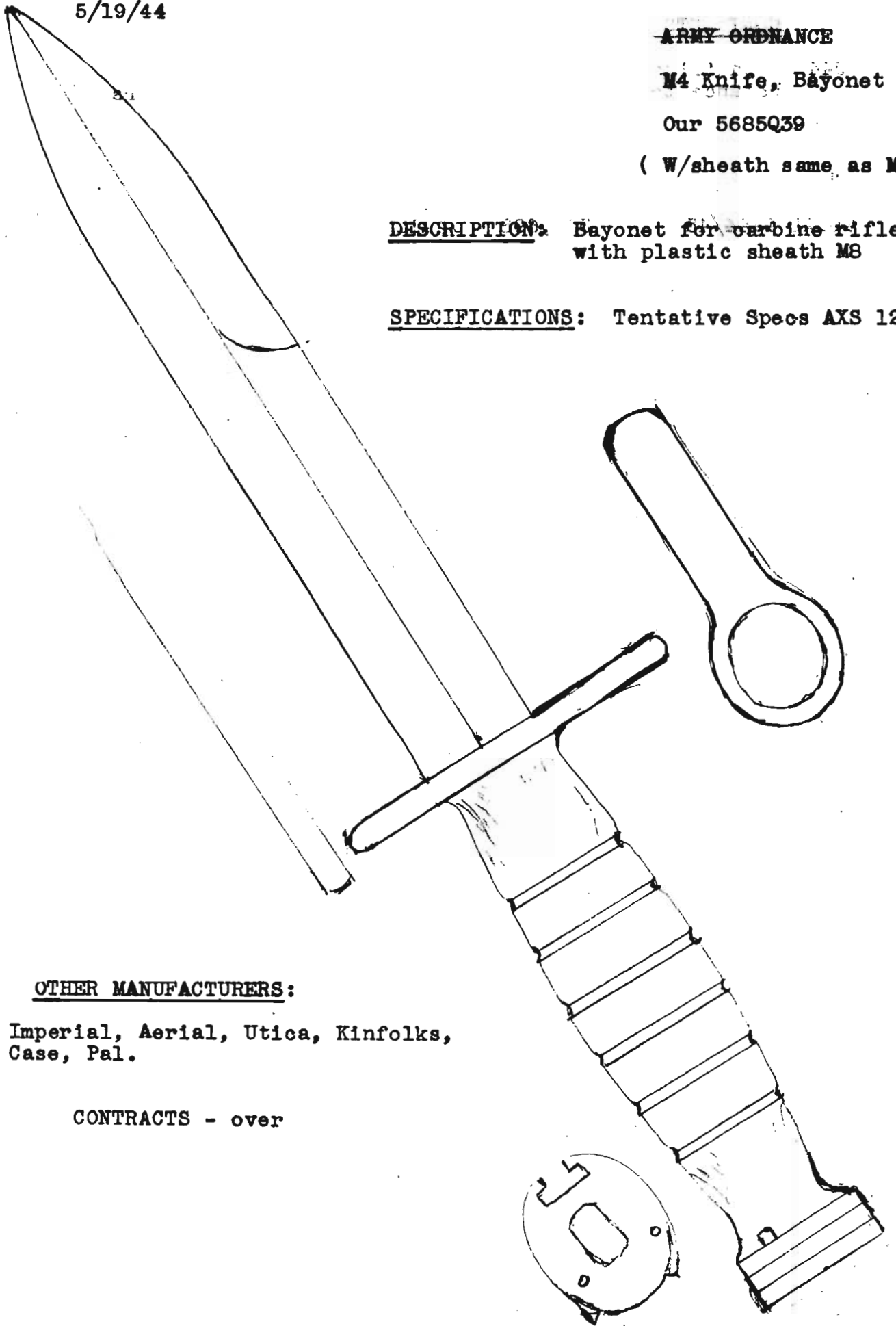

OTHER MANUFACTURERS:

Imperial, Aerial, Utica, Kinfolks,  
Case, Pal.

CONTRACTS - over

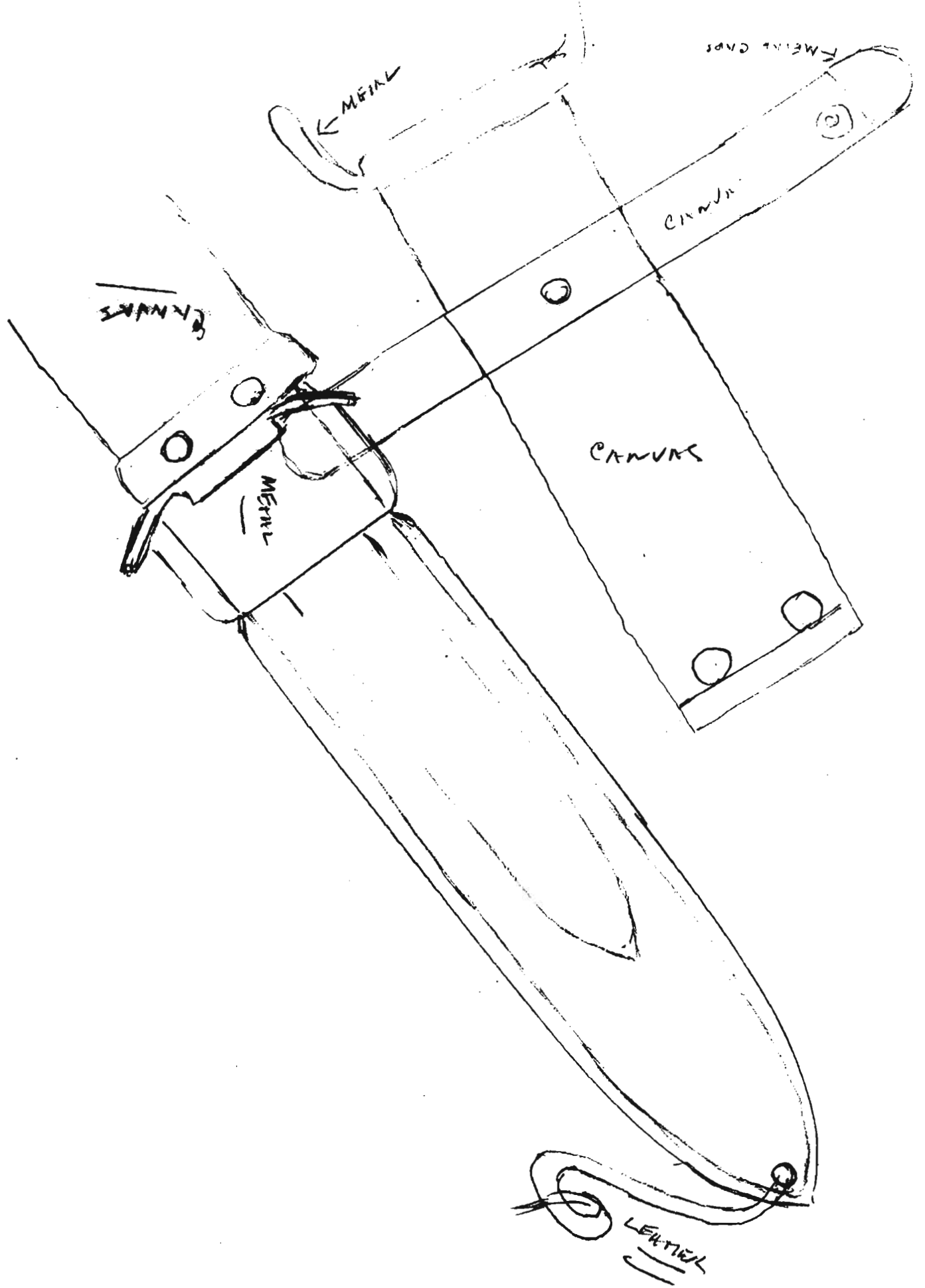

CONTRACTS

1944	Camillus	224,893	
	balance to make up 1,000,000 to other manufacturers		
"		50,000	
"		<sup>7,805</sup> 105,107	
<b>TOTAL 1944/45</b>		<u>382,698</u>	<b>CAMILLUS</b>
		<sup>57,805</sup>	
		<u>274,893</u>	

MACHETE

12/30/43

ARMY AIR FORCES

MACHETE (in metal sheath)

Govt # -  
Our # 5678 L 35

DESCRIPTION - Folding machete with molded handle, in metal sheath

SPECIFICATIONS - Air Corps Drawing S-42-d-7462

CHANGES - none

OTHER MANUFACTURERS - W.R. Case, Cattaraugus;

USES - by AAF in all emergency kits and equipment for jungle use

CONTRACTS - ~~Camillus, 114,000~~

see other side

~~Others, 180,000~~

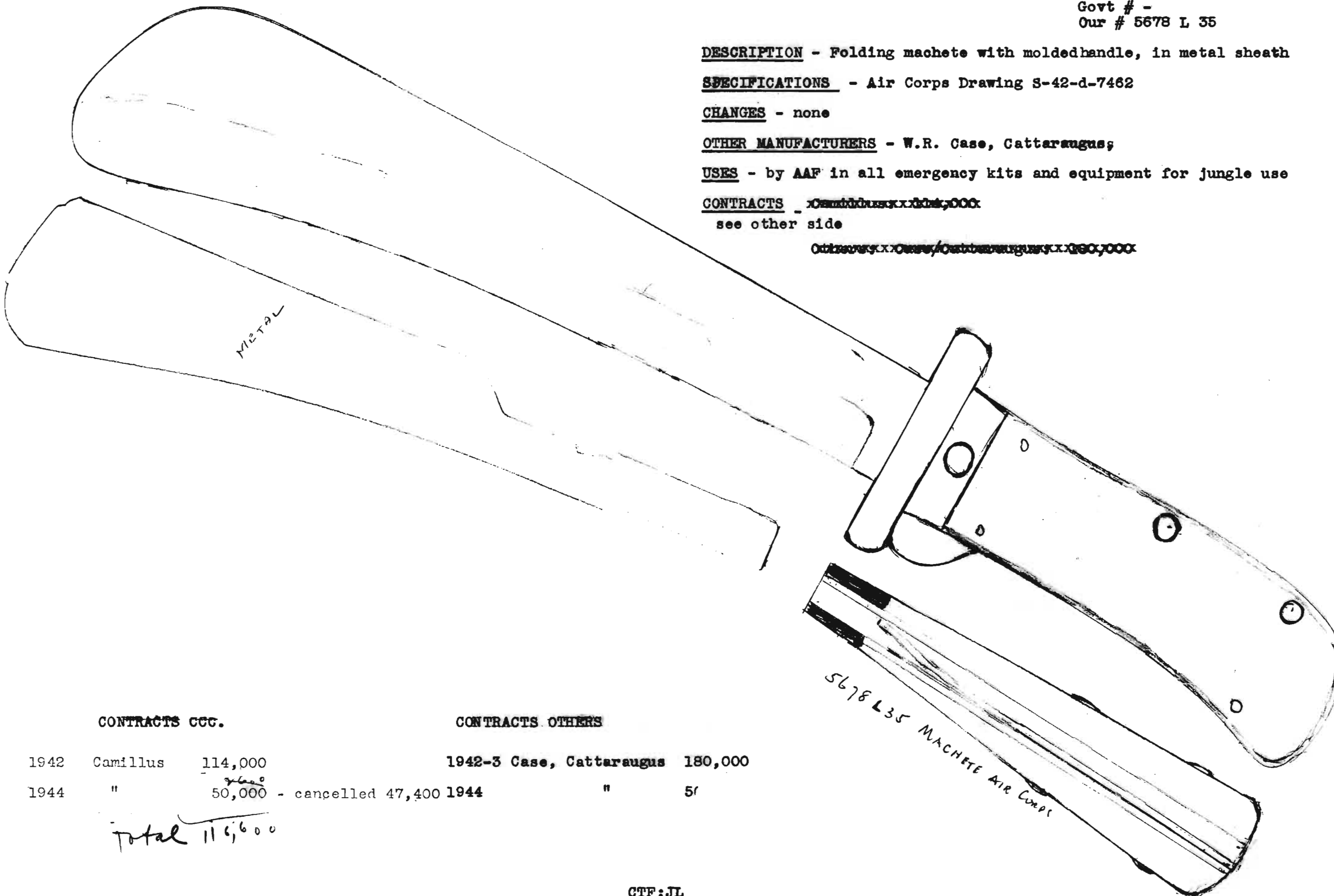

CONTRACTS CGC.

1942	Camillus	114,000
1944	"	50,000 - cancelled

Total 116,600

CONTRACTS OTHERS

1942-3	Case, Cattaraugus	180,000
1944	"	50,000

5678 L35 MACHETE AIR CORPS

1/10/44

SHEATH KNIFE - 7" blade

Our 5684L77 or  
5684Q3

NAVY DEPARTMENT

Their Mark 2.

With plastic sheath from Beckwith Mfg. Co., Victory Plastic Division, or leather sheath from A.L. Siegel Co., or Boyt-Harness

DESCRIPTION & SPECIFICATIONS

MC Drawing 1219C2c - with leather sheath, on first order.

CHANGES

On order 12/17/43 changed to Q3 and approved by Bureau of Ordnance. With plastic sheath.

USES

Fighting Knife

CONTRACTS

942-3	Camillus	331,600
	Boker	50,000
	Pal	75,000
	Robeson	90,000
	Union	60,000
944	Camillus	250,000
	Union	50,000
	Robeson	100,000
.945	Camillus	175,000 <i>terminated 6/7/50</i>

OTHER MANUFACTURERS:

Union, Robeson, Geneva Forge, Colonial Knife Co., Imperial, Pal, Ulster.

CFP:JL

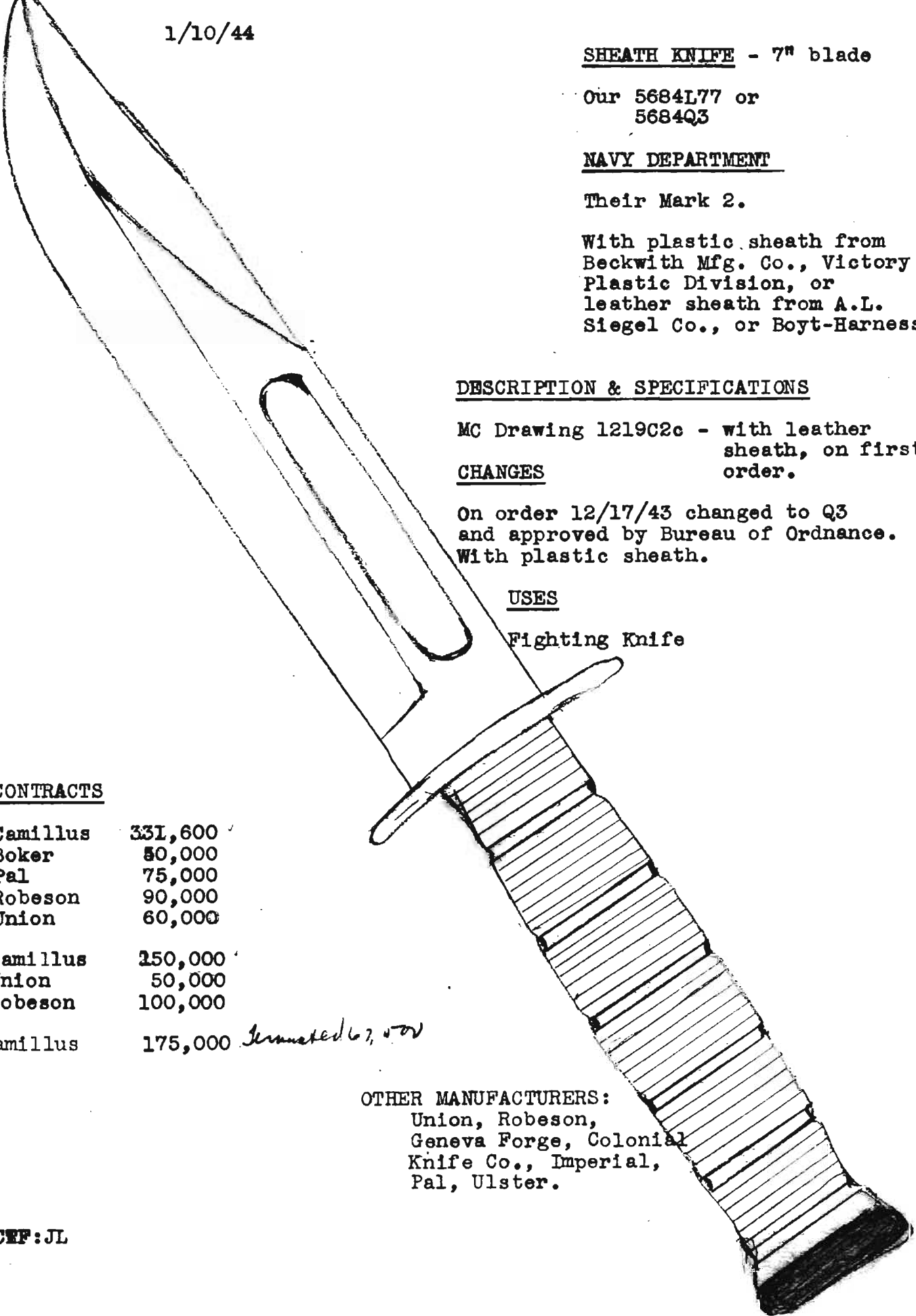

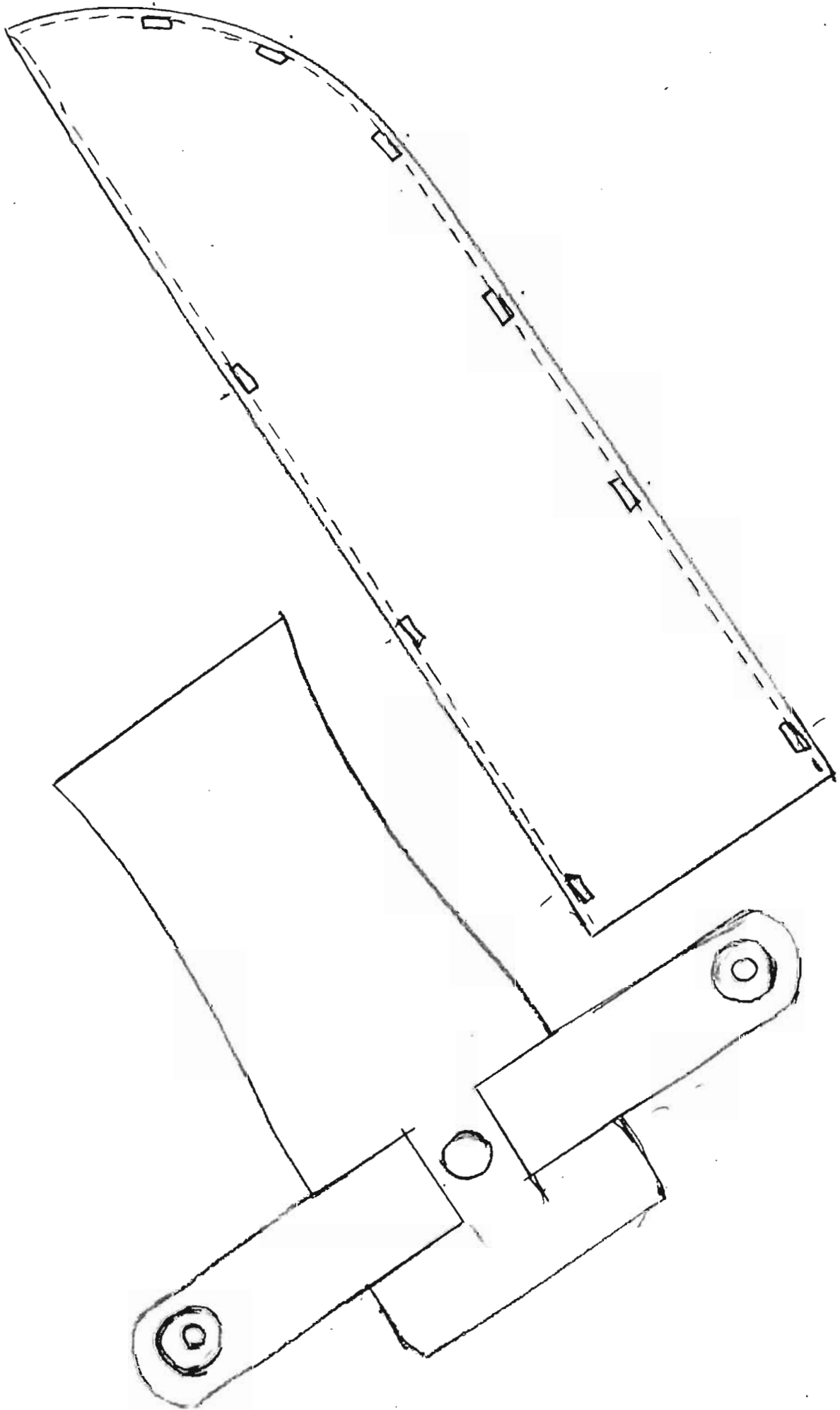

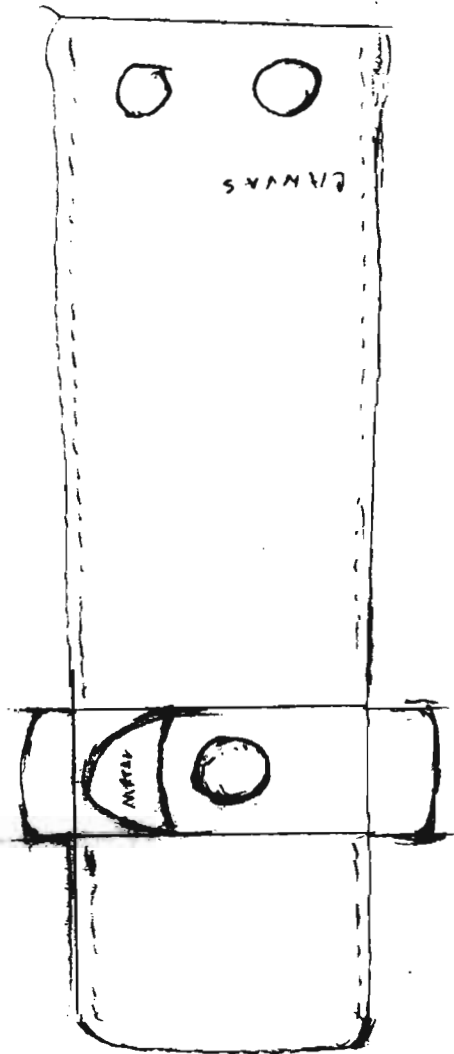
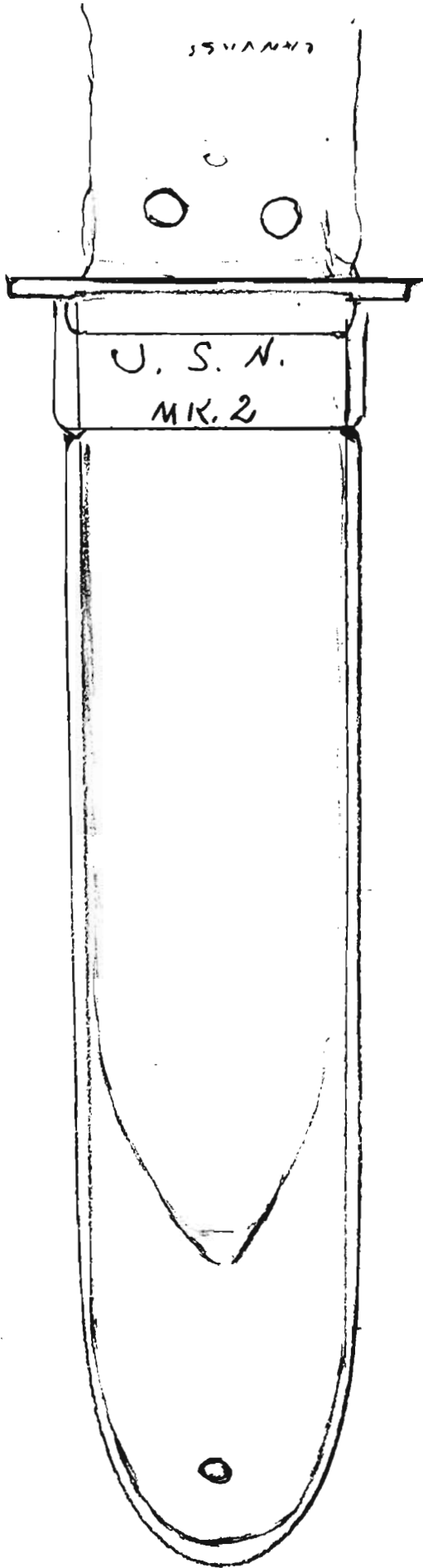

Very Plastic Sheath

Q3.



1/10/44

SHEATH KNIFE - 7 " blade

Our 5684L77 or Q3

MARINE CORPS

(See same knife made for the Navy)

With leather sheath from Boyt-Harness Co.

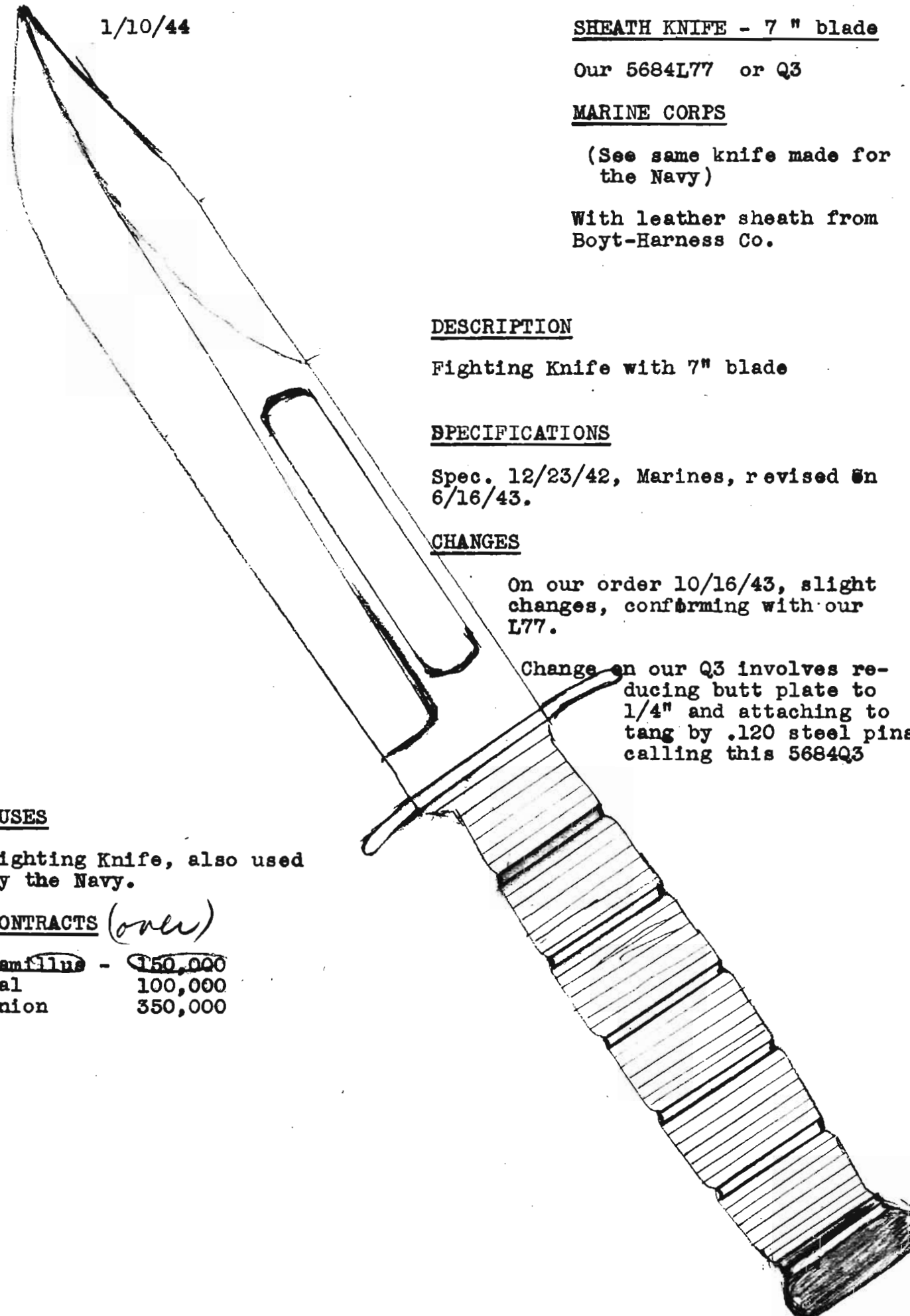

DESCRIPTION

Fighting Knife with 7" blade

SPECIFICATIONS

Spec. 12/23/42, Marines, revised on 6/16/43.

CHANGES

On our order 10/16/43, slight changes, conforming with our L77.

Change on our Q3 involves reducing butt plate to 1/4" and attaching to tang by .120 steel pins calling this 5684Q3

USES

Fighting Knife, also used by the Navy.

CONTRACTS

*(over)*

<del>Camillus</del>	-	<del>150,000</del>
Pal		100,000
Union		350,000

Marine Corps - sheath for 7" knife

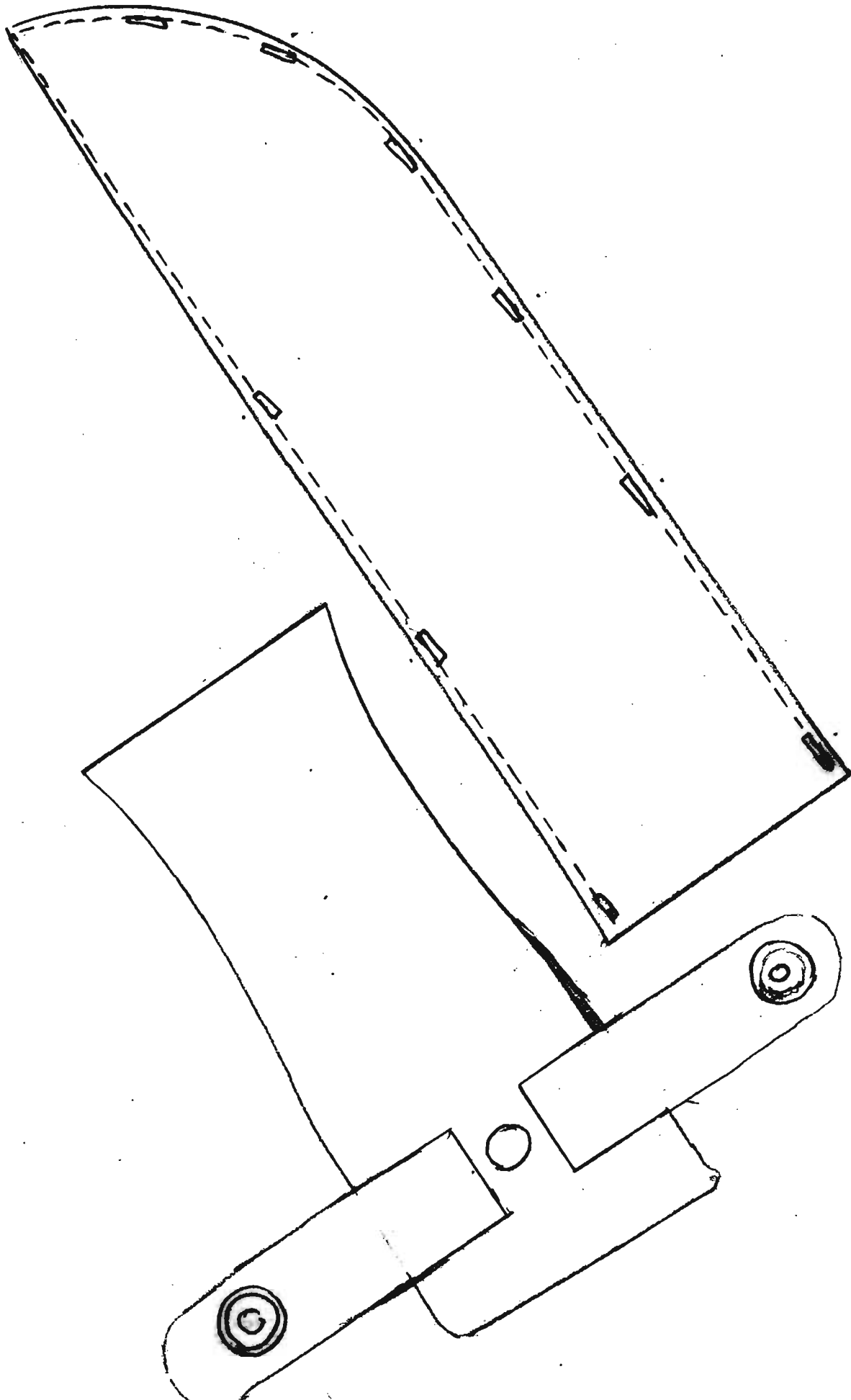

PRIME CONTRACTS:

1943  
1944  
1945

150,000 ✓  
150,000 ✓  
125,000 ✓

*Amount \$3,000*

1/10/44

SHEATH KNIFE - 5" blade

Our No. 5683 L75 Parkerized

Our No. 5683L94 -not Parkerized

FOR NAVY DEPARTMENT

MARK I.

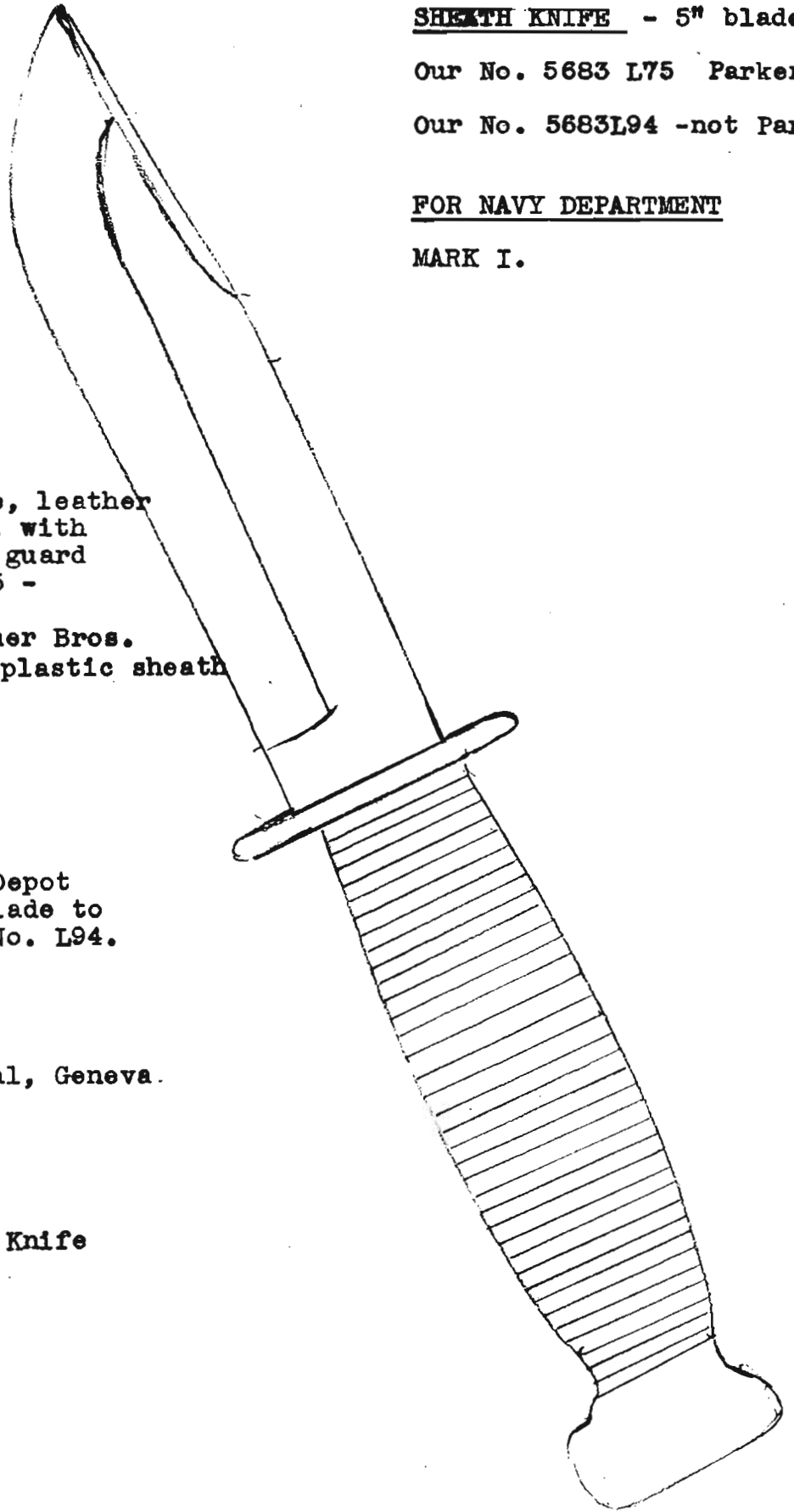

DESCRIPTION

5" sabre ground blade, leather handle, plastic butt, with steel nut, blade and guard parkerized on 5683L75 -

With sheath from Brauer Bros.  
9/13/44 - changed to plastic sheath

SPECIFICATIONS

none

CHANGES

Boston Naval Supply Depot changed Parkerized blade to glazed blade, under No. L94.

OTHER MANUFACTURERS

Robeson, Colonial, Pal, Geneva.  
Forge Cutlery Co.

USES

Utility and Fighting Knife

CONTRACTS

12/3-	Camillus	- 135,000 -
	Robeson	175,000
	Colonial	175,000
	Pal	140,000
	Geneva	120,000
1944	Camillus	135,482

1945 Camillus 195,000 *Transferred*

NAVY DEPARTMENT - Sheath for 5" knife

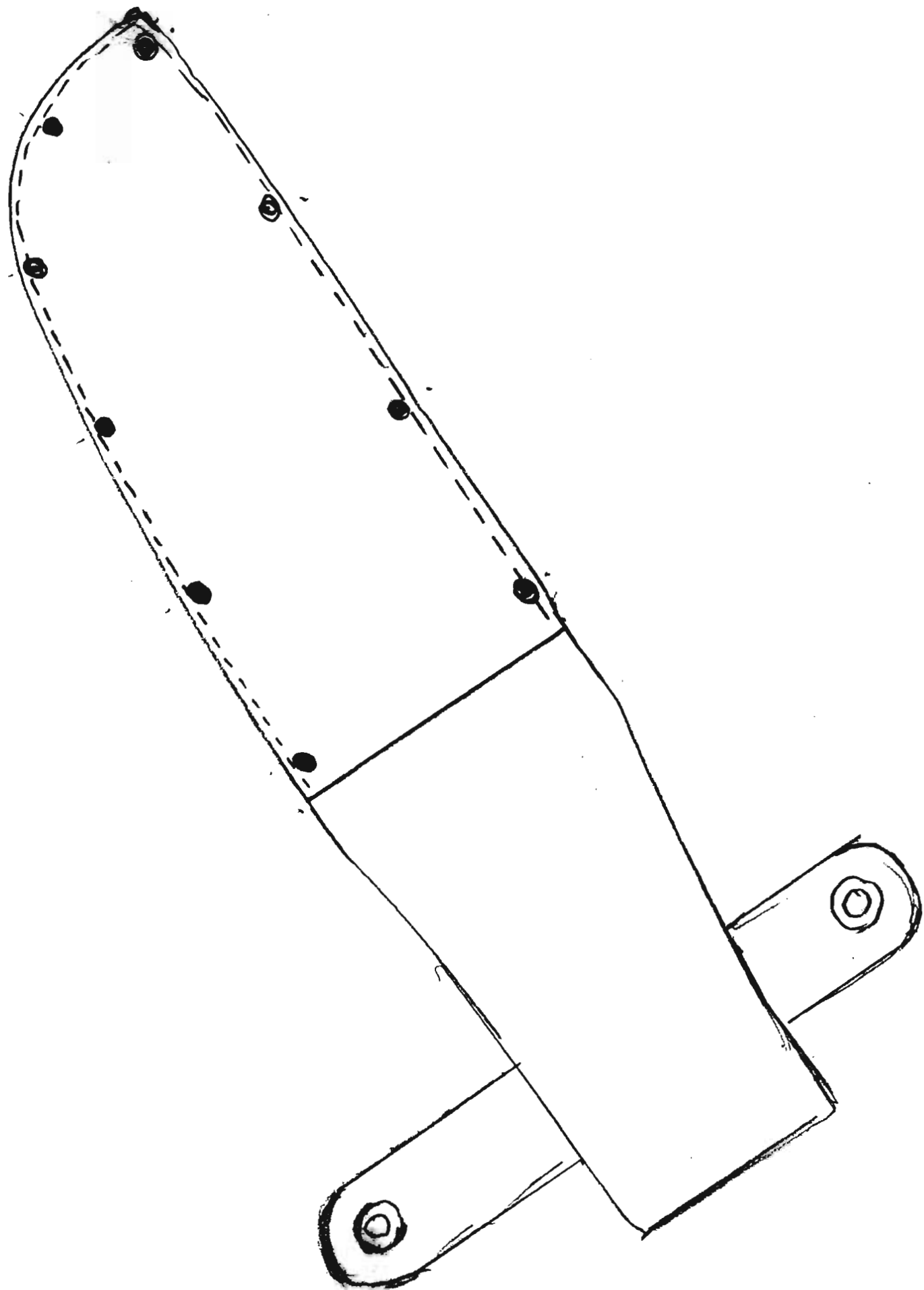

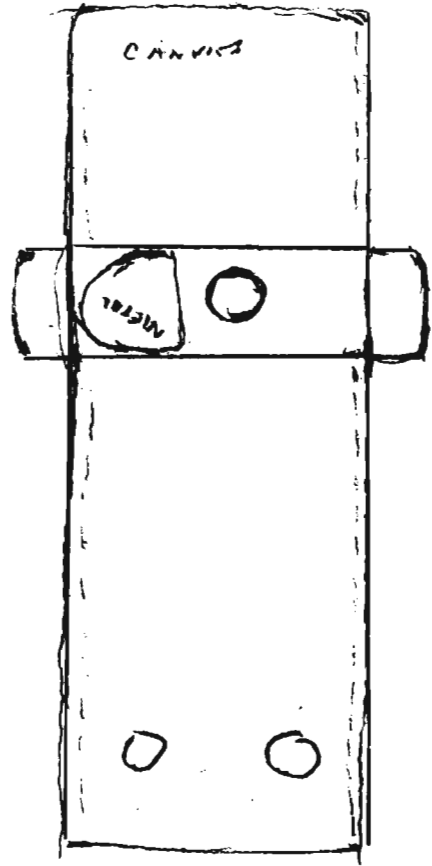
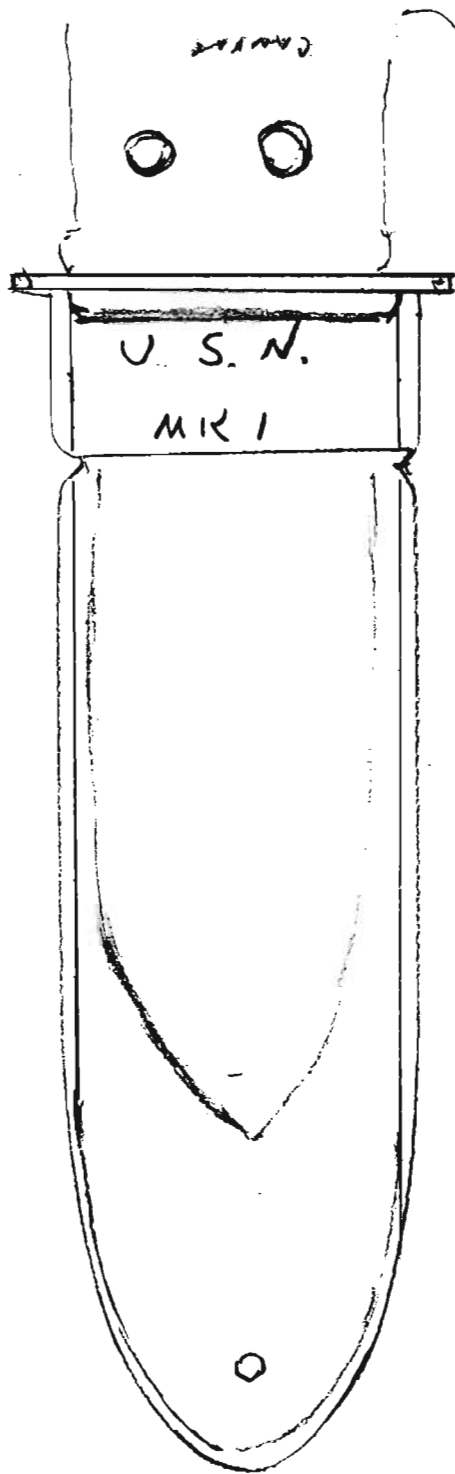

MEDICAL TENATOME

U.S. NAVY

Gov't No. - Stock 3-890

Our No. - 5674 L 45

M D - USN

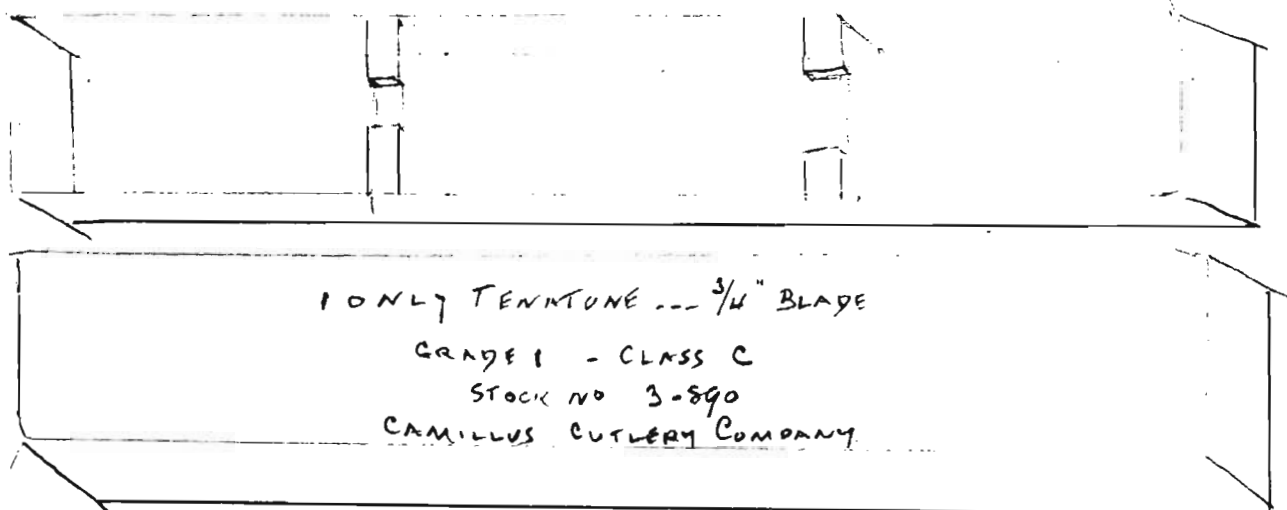
I. DESCRIPTION

Cost Book Sheet S-50 - 9/10/42  
 3/4" blade, A finish  
 Chrome plated handle, 3 1/2" long

2. SPECIFICATIONS

Navy Medical 57-I-3 of 7/1/41  
 Hardened steel, chromium plated over nickel over copper  
 Marked - M.D. U.S.N.

Packed in individual telescope boxes with transparent window,  
 knife suspended in box on blocks.

Size and shape like Sklar #311 blade G or equal.

A. CHANGES

#1 - length of blade 3/4" instead of 1 1/16"

3. OTHER MANUFACTURERS

Sklar, Langbein, Oneida, Wigder, Geo. Tiemann

4. USES

In emergency operating kit with other types of medical  
 operating knives.

5. CONTRACTS

MISCELLANEOUS POCKET KNIVES

10/27/43  
JERSEY CITY QUARTERMASTER DEPOT

Assortments: 1A, 2A, 1B, 2B, 1C  
1D, 1E

Description:

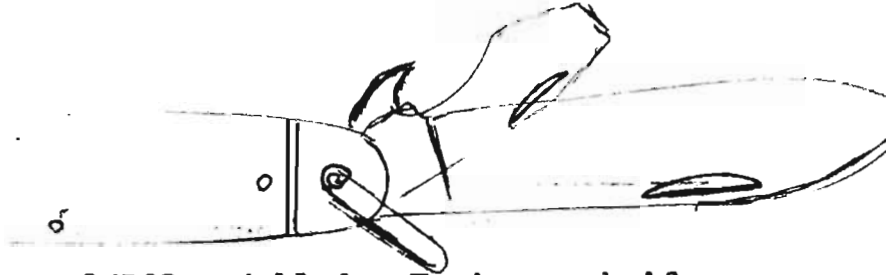
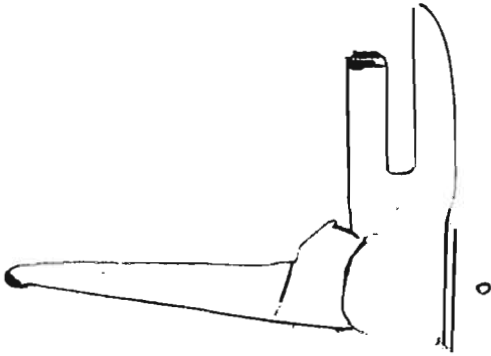

14L68 - 4 blade, Engineers knife,  
no shield

Assortment 1D consists of:  
14L68-14L69-57L70

Assortment 1E: 14L68-14L69-57L93

Assortment 1G: SR numbers 9525,9509,9508

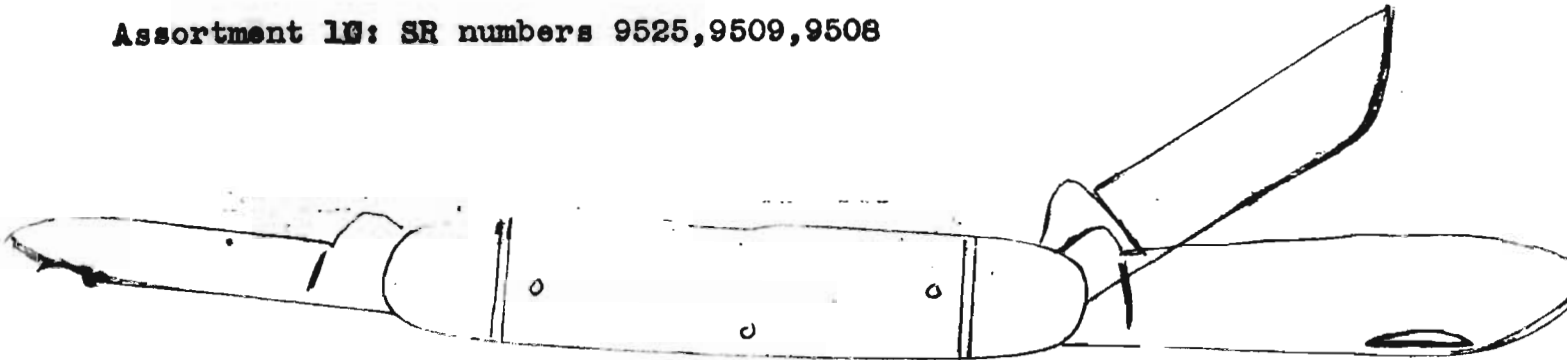

14L69 - 14/3 bone stag, spear and  
pen, all steel, no shield, black  
inside, SFAA

Specifications:

At first brought any knives available,  
preferably better quality - assortments  
#1 - higher priced items; assortments #2  
lower priced; assortments 1A-2A-1B-2B  
miscellaneous items, assorted S.B. and  
stock numbers as per factory orders.

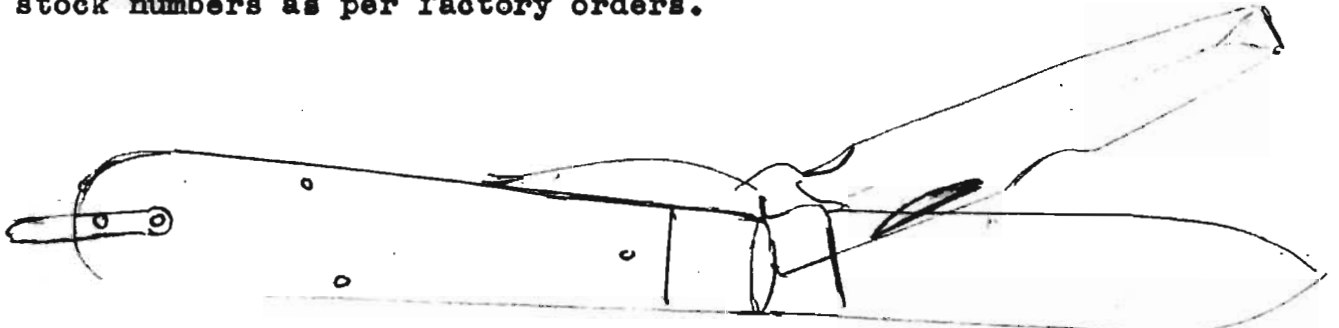

57L70 - 57/2 electricians, spear, long  
screwdriver, all steel, rosewood,  
like 57L49 but no "TL-29"

57L93 - Same as 57L70 but bone stag  
handle.

Other manufacturers:

Case, Cattaraugus, Ulster, Imperial

CONTRACTS

Camillus - 874,838 assorted

Others - received combined slightly more than the total business we have received.

1/26/44 - Imperial received an order for 400,000 for domestic post exchanges of 3 different knives, a large part of which was a 4 blade camp, bone stag.

USES

Bought for resale through foreign- post exchanges. Resale price slightly above cost price, just sufficient to cover handling.



14L79

NAVY AVIATION

REG. NO. 555-15597

CONT. N 2285-24170

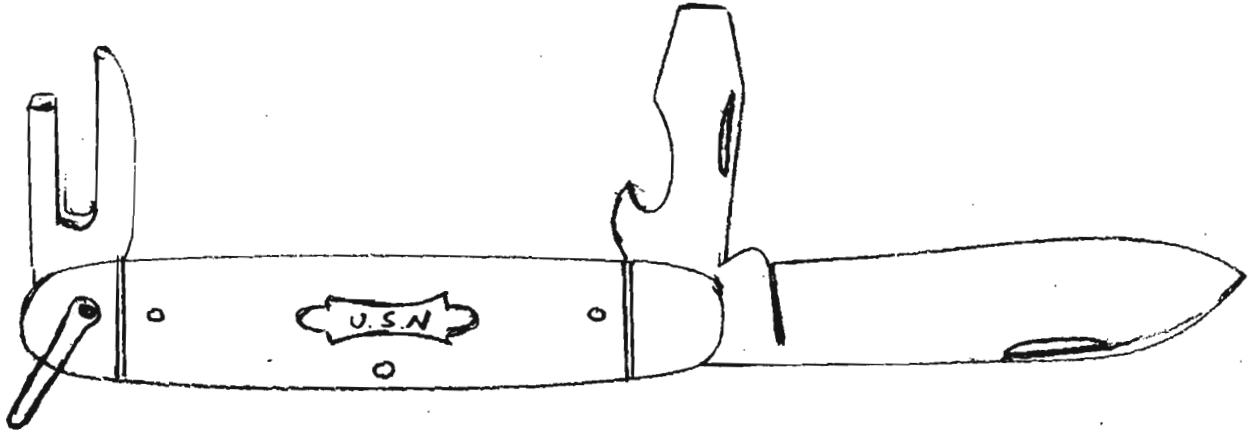

N 14S 2    0 brass linings & center scales

049 14299

14L79    Spear, canopener 14-1, screwdriver caplifter. Linings, center scales and springs zinc plated. All steel.

14S2    Brass linings and center.

CONTRACTS:    1944            54,246 ✓

NAVAL AVIATION SUPPLY DEPT  
DIXIE BARRACKS

PARING KNIFE

Govt. Stock# 64-K\*660-65

Our No. 5587J57

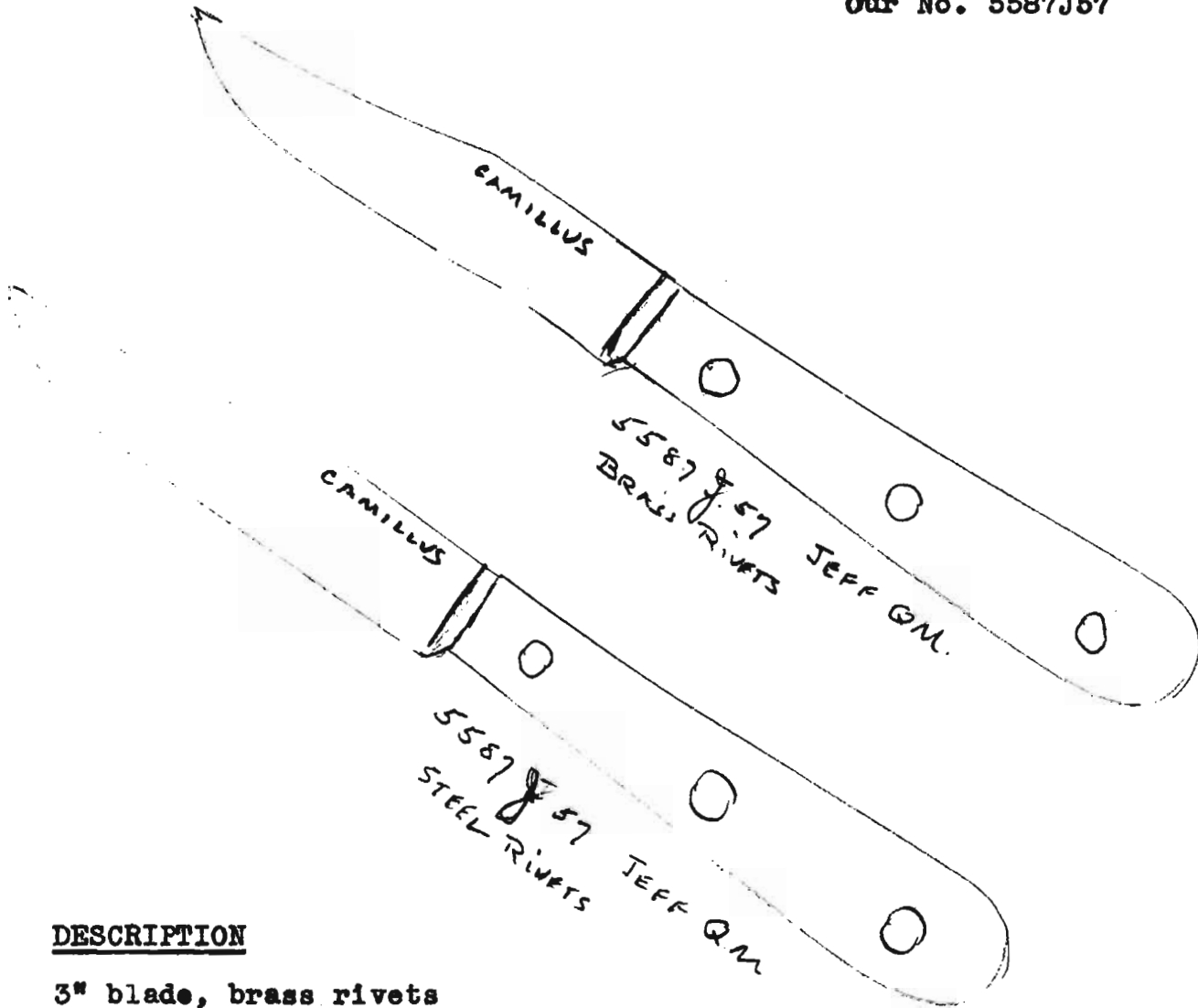

DESCRIPTION

3" blade, brass rivets

SPECIFICATIONS

QM 28-119, type IV

CHANGES

9/9/42 - revised to steel rivets

OTHER MANUFACTURERS

Clyde Cutlery Co., Ontario Cutlery Co.

CONTRACTS

Camillus: 12,342; 11,396; 62,640

10/27/43

SAILORS SPIKE KNIFE

U.S. NAVY

For Lend Lease to British Navy

Gov't No. - Class 251

Our No. - 7085 J 72 Rosewood

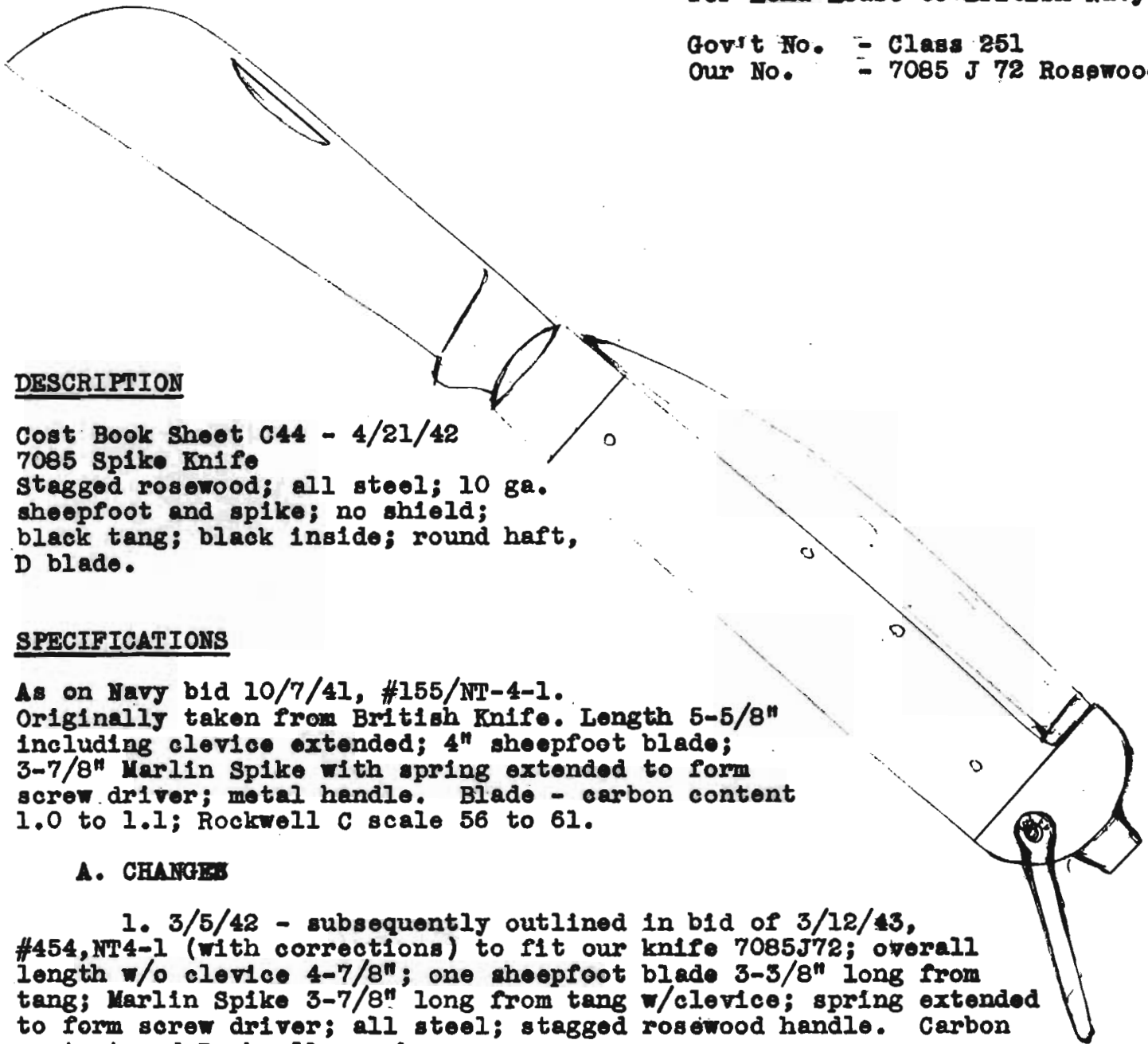

1. DESCRIPTION

Cost Book Sheet C44 - 4/21/42  
7085 Spike Knife  
Staggd rosewood; all steel; 10 ga.  
sheepfoot and spike; no shield;  
black tang; black inside; round haft,  
D blade.

2. SPECIFICATIONS

As on Navy bid 10/7/41, #155/NT-4-1.  
Originally taken from British Knife. Length 5-5/8"  
including clevice extended; 4" sheepfoot blade;  
3-7/8" Marlin Spike with spring extended to form  
screw driver; metal handle. Blade - carbon content  
1.0 to 1.1; Rockwell C scale 56 to 61.

A. CHANGES

1. 3/5/42 - subsequently outlined in bid of 3/12/43,  
#454, NT4-1 (with corrections) to fit our knife 7085J72; overall  
length w/o clevice 4-7/8"; one sheepfoot blade 3-3/8" long from  
tang; Marlin Spike 3-7/8" long from tang w/clevice; spring extended  
to form screw driver; all steel; staggd rosewood handle. Carbon  
content and Rockwell as above.

2. 3/12/43 - back of spring glazed instead of black.

3. OTHER MANUFACTURERS

Ulster Knife Co.

4. USES

By British sailors for general utility, splicing ropes, opening knots  
and emergency.

5. CONTRACTS (to date)

11/4	Camillus	-	3	contracts:	8000	-	11,000	-	10,000
	"		1		36,000				
	Ulster Knife Co.		1	contract			-	11,000	

68,088  
65,000  
Total 29,000  
" 11,000

SAILORS JACK KNIFE

MARITIME SERVICE

- Gov't No.
- (A) 1 blade - Our No. 425L21 RW
- (B) 2 blades - Our No. 5541 J 51  
bone stag.

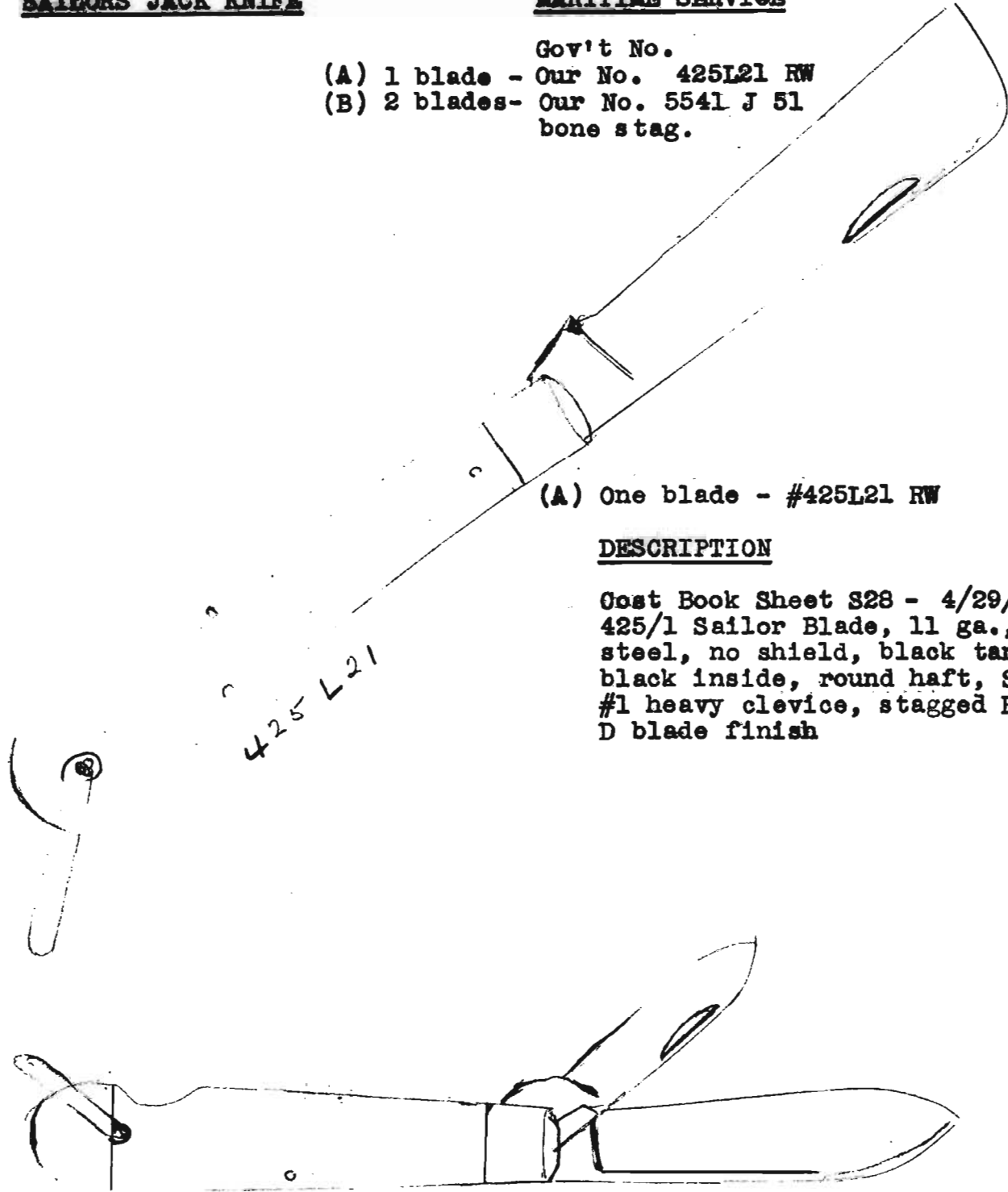

(A) One blade - #425L21 RW

DESCRIPTION

Cost Book Sheet S28 - 4/29/42  
 425/1 Sailor Blade, 11 ga., all  
 steel, no shield, black tang,  
 black inside, round haft, SFAA,  
 #1 heavy clevice, stagged R.W.  
 D blade finish

(B) Two blade - #5541 J 51

DESCRIPTION

Cost Book Sheet S-124, 12/31/41  
 Bone stag, 5541/2 brass and n/s  
 bolster, no shield, 3 tang,  
 painted inside, round haft, SFAA

SPECIFICATIONS

One blade knife - same as Maritime Commission, Bureau of Marine Inspection and Navigation.

Two blade knife - no specifications

CHANGES

OTHER MANUFACTURERS

Imperial, Utica, Ulster

USES

General utility aboard ship and emergency in event of sinking.

CONTRACTS

One blade Knife - to date - total 77,000

Two blade Knife - <del>to date</del> -	1942	109,000
PRIME CONTRACTS	1943	204,188
	1944	44,237
	1945	85,000

2 blade SUB-Contracts	1942	48,000
	1943	- 158,764
	1944	43,944
	1945	1464

SAILORS JACK KNIFE

Govt. No.  
Our No. 425 L 39

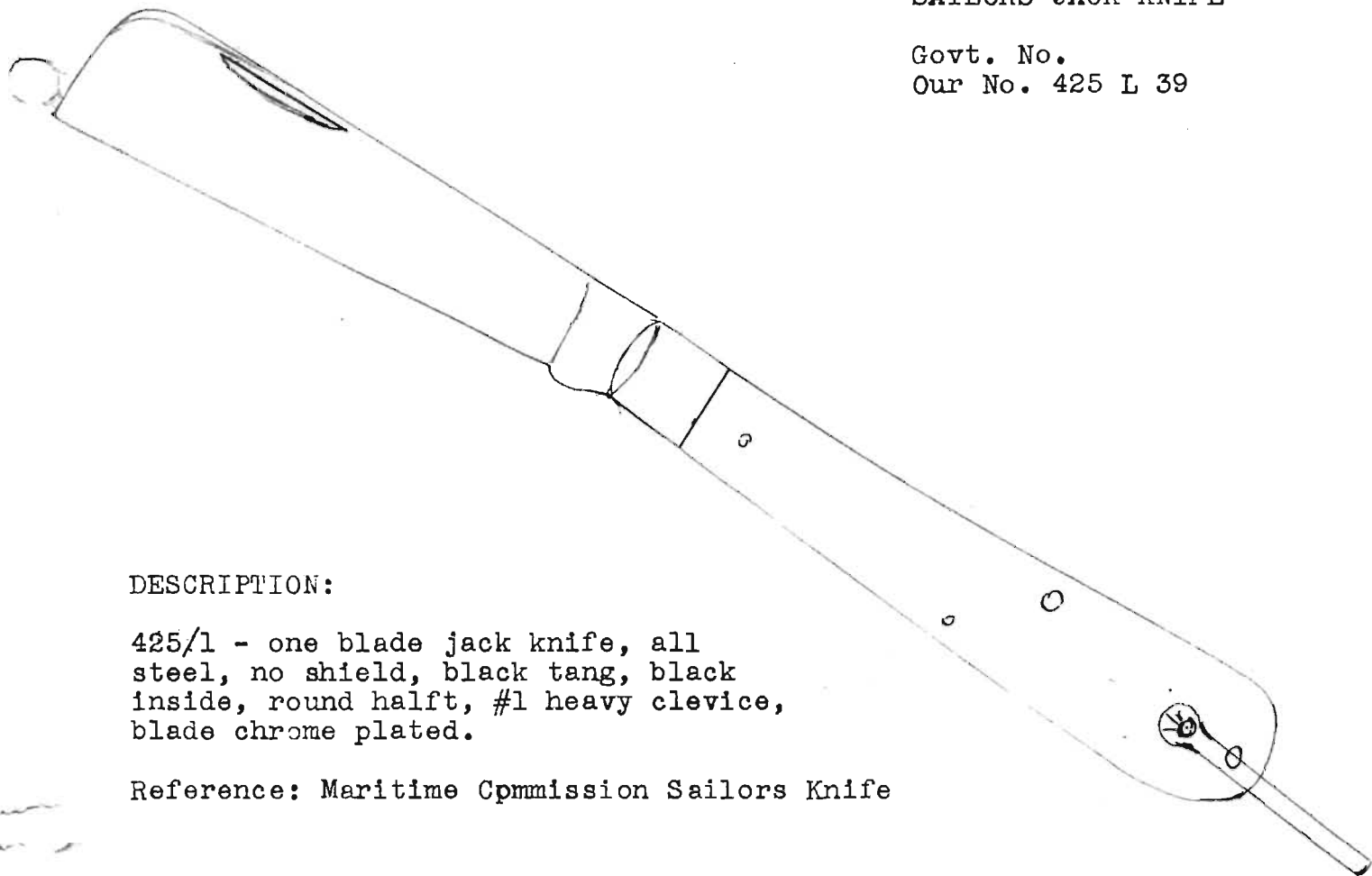

DESCRIPTION:

425/1 - one blade jack knife, all steel, no shield, black tang, black inside, round half, #1 heavy clevice, blade chrome plated.

Reference: Maritime Commission Sailors Knife

SPECIFICATIONS:

none

Like Bureau of Marine Inspection and Navigation's specifications, but chrome plated.

USES:

General utility aboard ship, emergency in event of sinking.

OTHER MANUFACTURERS:

CONTRACTS:

5,000 - 20,000  
7,000

SURGICAL KNIVES

U.S. ARMY MEDICAL

and for Lend-Lease

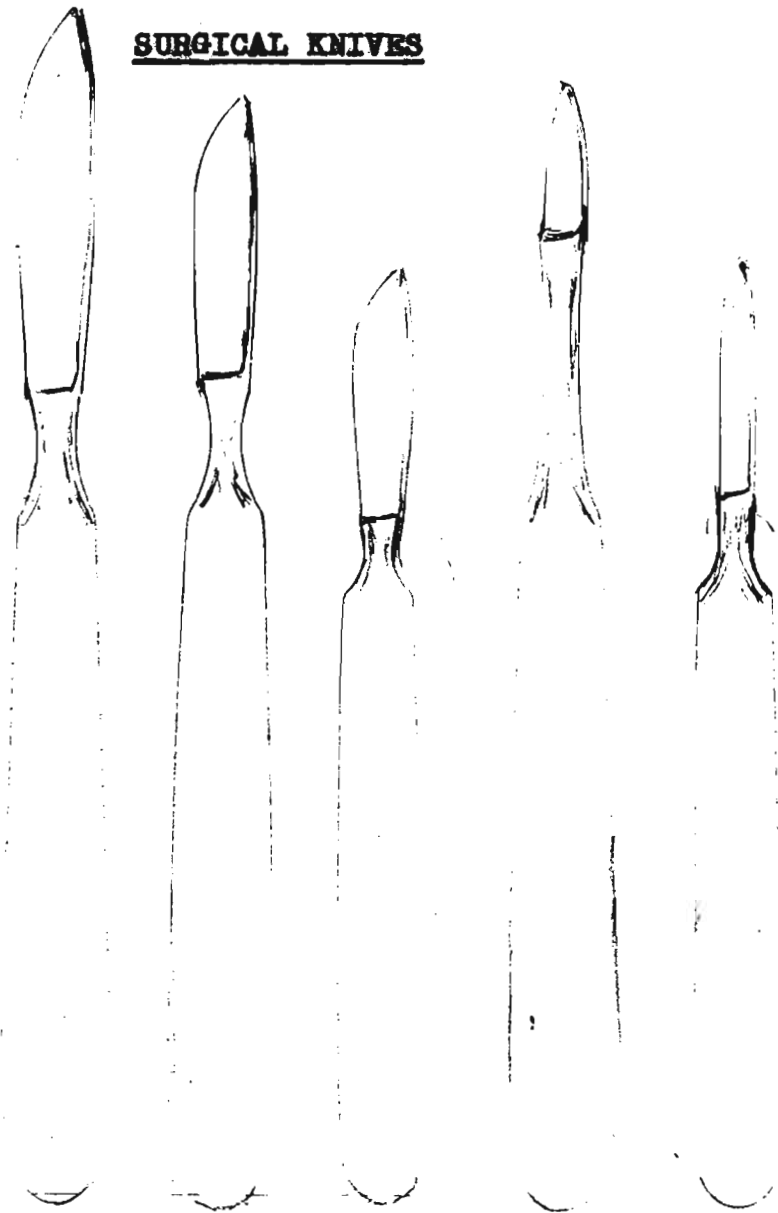

DESCRIPTION

1. 33362 - our 5676L14  
2" Operating Knife <sup>PLATED</sup>
2. 33359 - our 5675L13  
1 1/2" Operating Knife
3. 33356 - our 5680L60  
1 1/4" Operating Knife
4. 33410 - Tenatome 3/4"  
carbon steel, chrome  
plated, nickel over  
copper, blade not plated  
glazed finish -5674L12
5. 30085 - our 5681L61  
Bistoury, straight  
blade 1-5/16"

See Cost page S50-9/10/43

Identical handles on the 1 1/2", and 2" operating and on the tenatome.

Identical handles on the 1 1/4" operating and on bistoury.

	33362	33359	33356	33410	30085
blade:	2"	1 1/2"	1 1/4"	3/4"	Bistoury 1-5/16"
overall-	6-1/8"	5-5/8"	4-3/4"	5-3/4"	4-13/16"
handle	-3-5/8"	3-5/8"	3-1/8"	3-5/8"	3-1/8"

Plating and blade finish same on all knives.

SPECIFICATIONS

Surgical knives 10-2277B dated 1/14/42, also 10-2996.

Changes: handles of knives standardized as noted above. Changed from different types on each knife as used previously.

USES

Assembled in emergency kits for front line use.

OTHER MANUFACTURERS:

Tieman. Sklar. Ulster. International Silver

CONTRACTS

Tenatome -	2382 ea.
1 1/2" Operating -	85,629
1 1/4" Operating -	15,549
2" Operating -	10,068
Bistoury -	90,606

1/5/44

Navy Department

SPATULA - 12"

Our 5673L11  
Their Grade B, type X

DESCRIPTION:  
12" blade, wood handle

SPECIFICATIONS:  
Federal GGG-C-746 and  
Amend #1

CONTRACTS:  
Camillus - 7400 each

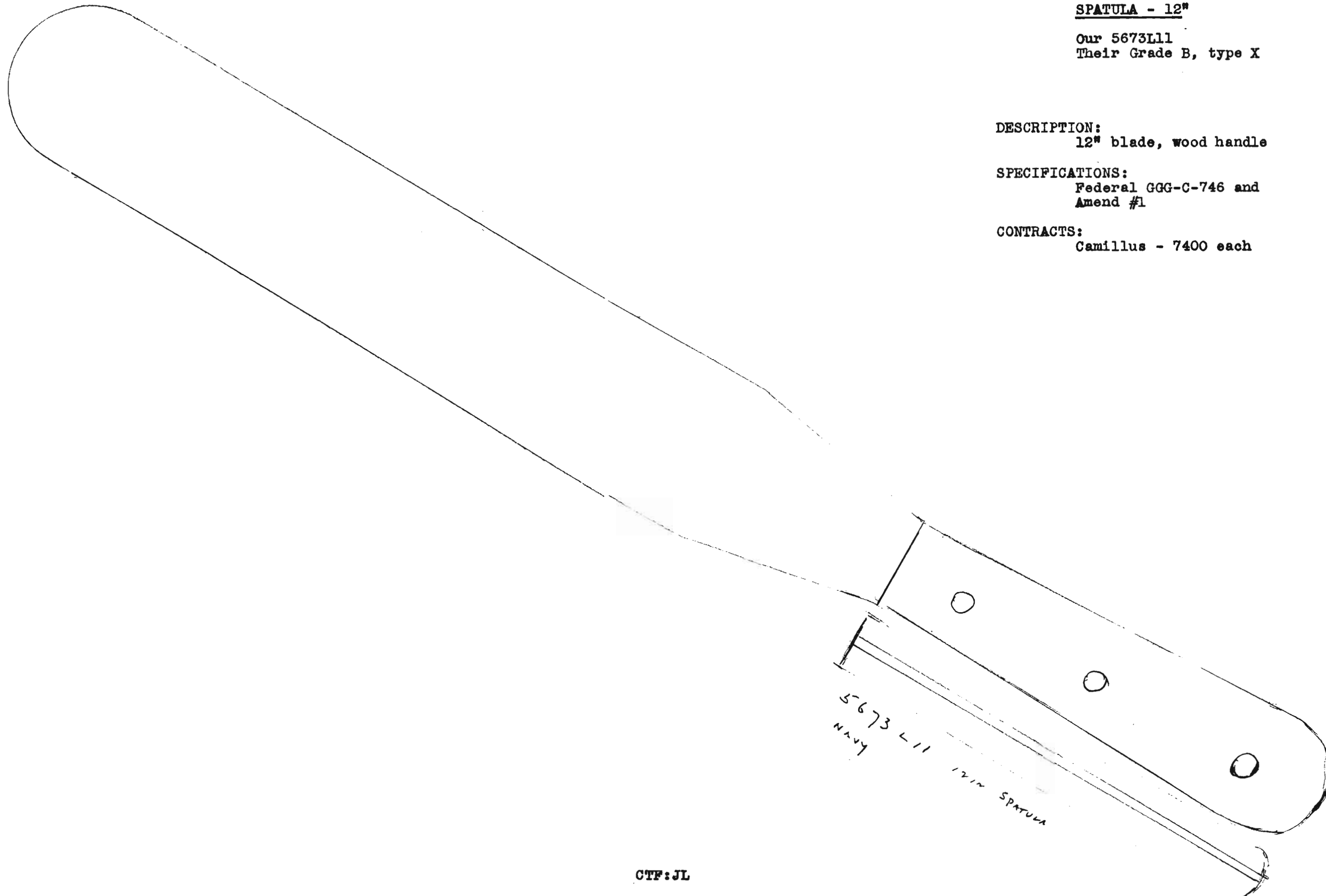

CTF:JL



1/5/44

NAVY DEPARTMENT

Spatula, 10"

SPATULA - 10"

Our 5672L10  
Their Brade B, type X

DESCRIPTION:  
10" blade, wood handle

SPECIFICATIONS:  
Federal GGG-C-746 and  
Amend.#1

CONTRACTS:  
Camillus - 10,900 only

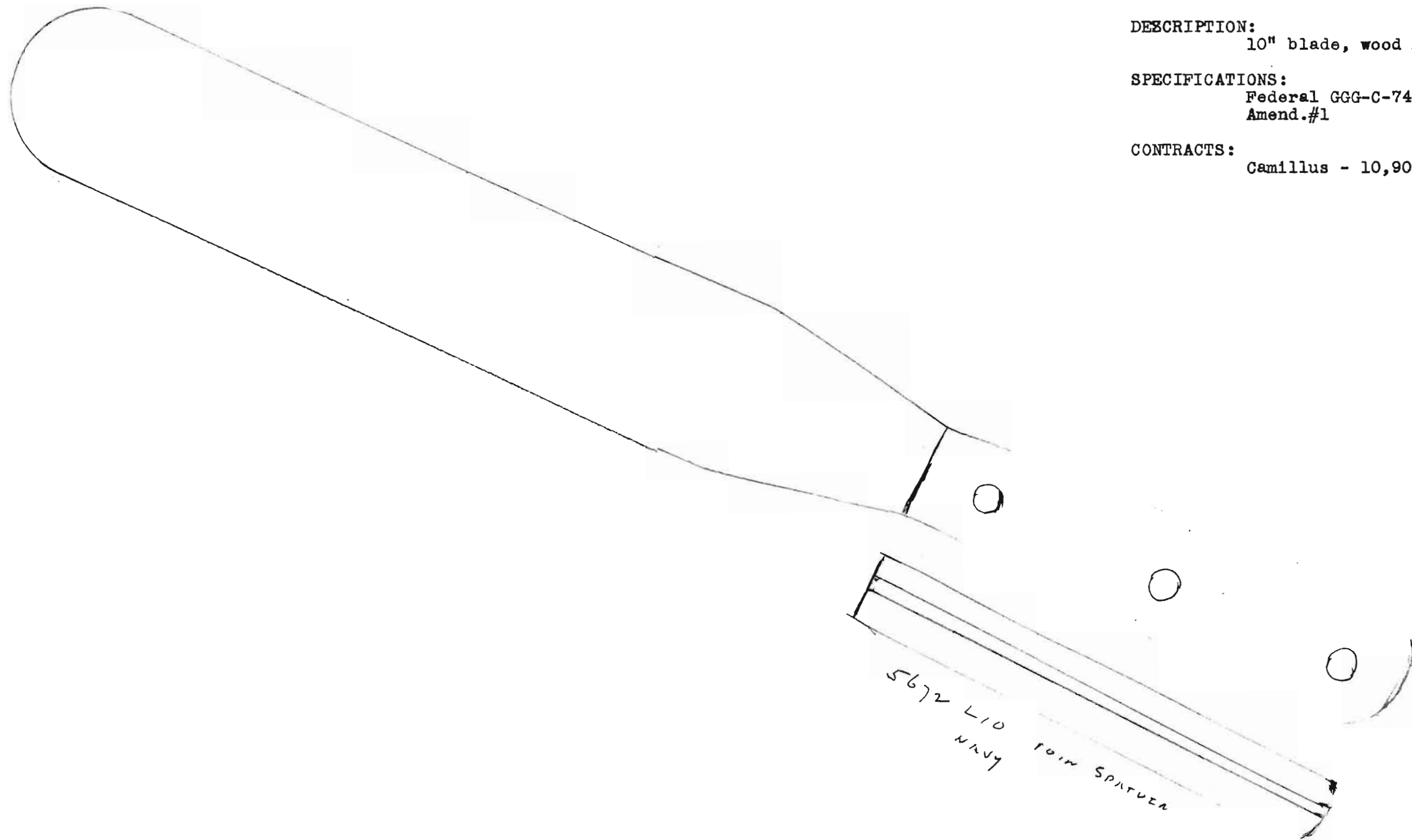

CTF:JL

Spatula 8"

1/5/44

Navy Department

SPATULA - 8"

Our 5671L9  
Their Grade B, type IX

DESCRIPTION:  
8" blade, wood handle

SPECIFICATIONS:  
Fed.GGG-C-746 and Amend #1

CONTRACTS:  
Camillus - 7,000 each

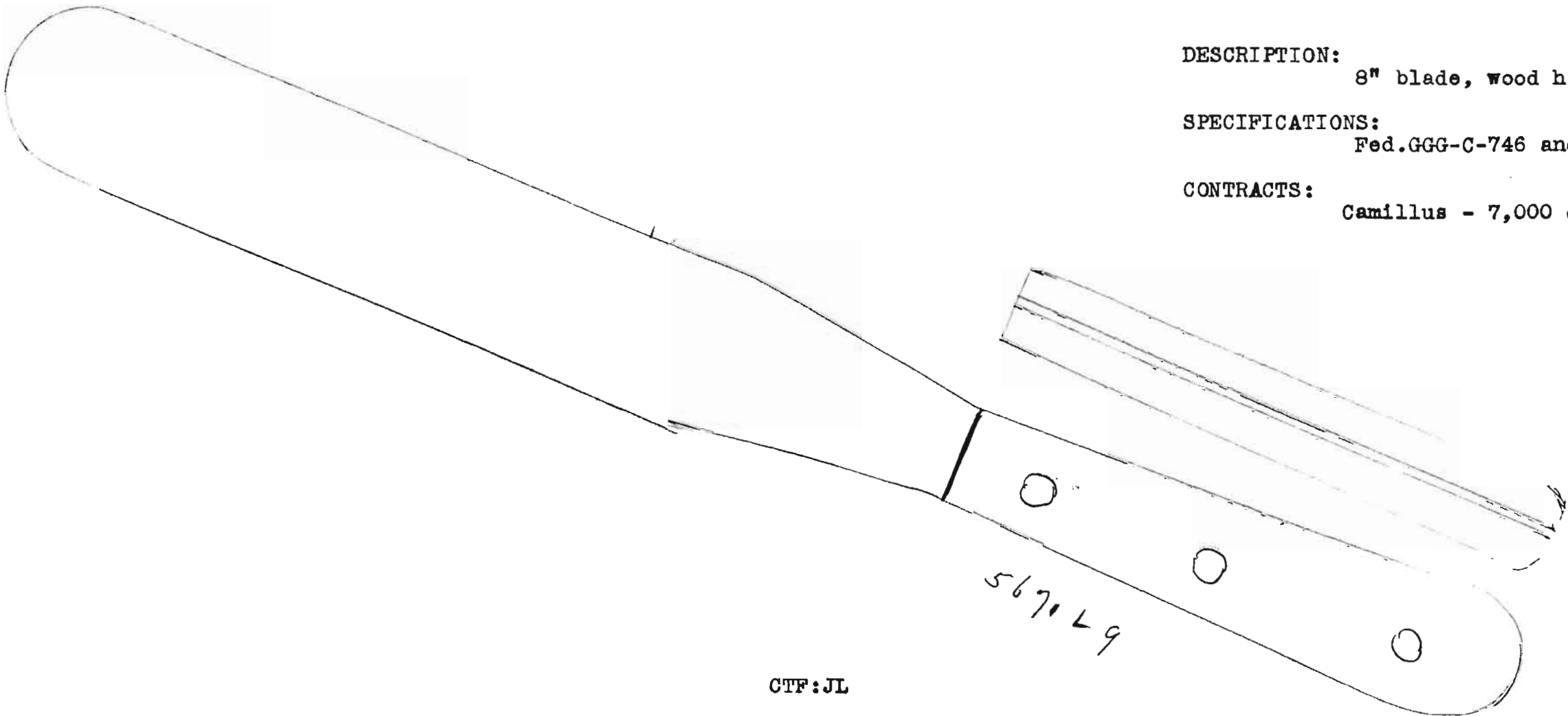

5671L9

CTF:JL

19/30/43

U.S. MARINE CORPS

STILETTO

Govt #

Our # 5677 L 99

(with Mosser sheath  
and thongs from Williams)

DESCRIPTION

7" double edge polished blade, zinc die cast handle, etching on blade.

SPECIFICATIONS

none

CHANGES

OTHER MANUFACTURERS - W.R. Case

USES - for the U.S.M.C. rangers

CONTRACTS - Camillus: 5,000; 9370:

Others:

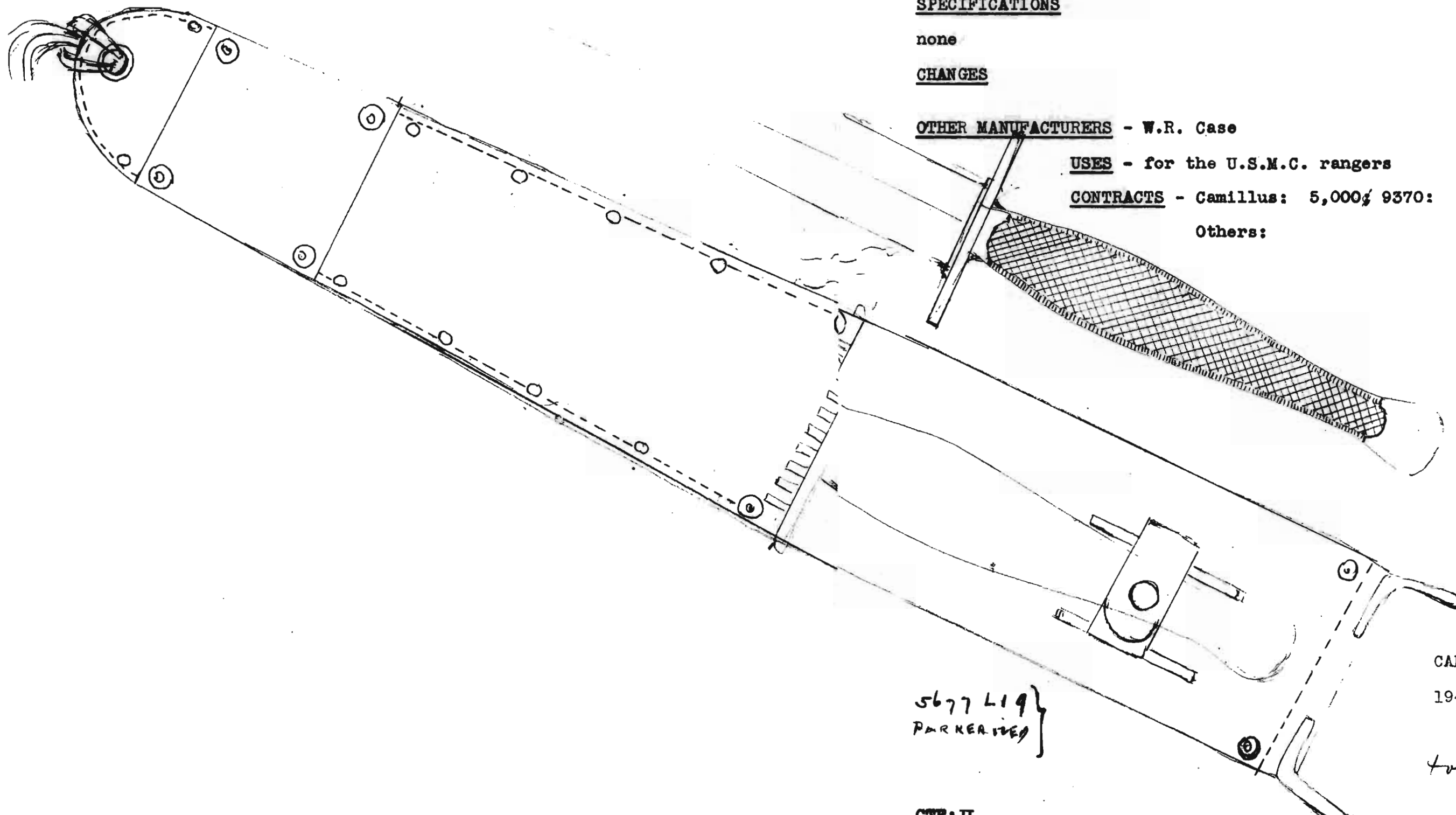

5677 L 99 }  
PARKER IDEP }

CAMILLUS

1942	5,000 ea.
	8,800 9370

total 14,370

SIGNAL CORPS

Govt No. - TL-29  
Our No. 57A73  
57J94  
57L49

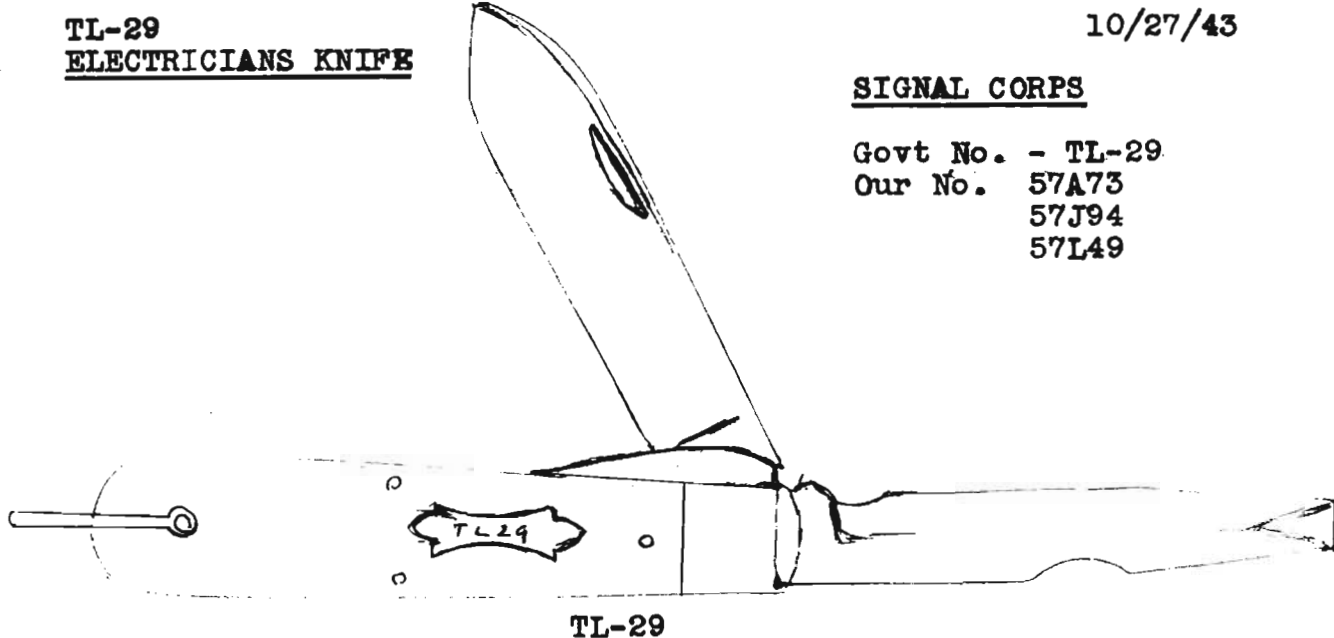

1. DESCRIPTION

57A73 - electricians knife, 1 blade and 1 screwdriver with locking device, shackle, rosewood handle. Under this number, the knife had brass lining and center lock, n/s shield, pins and shackle.

57J94 - Same description as above but: Steel linings and bolsters, brass center scale, n/s clevice, shield stamped TL-29. First order placed by Signal Corps on this number 3/30/42.

57L49 - Same description as above but: Steel bolsters, linings, rivets, pins, clevice and lock center scale. Handle stamped TL29. No shield.

2. SPECIFICATIONS

Specifications No. 71-569-C dated 3/8/38 which in turn superseded spec. 71-569-B of 5/25/35. Used for 57A73.

No new specifications written for 57J94.

9/17/42 - Amendment No. 1 issued but actually never fit the knife we started delivering on contract placed 9/4/42.

5/22/43 - Amendment No. 2 written with one correction still to be made. Par. E9 should read "Linings and Center to be of Steel" instead of brass.

3. OTHER MANUFACTURERS

Pal, Case, Utica, Union, Schrade, Ulster, ~~Cattaraugus~~, Robeson.

USES

By Signal Corps, Marines, Engineers, Quartermaster, Navy;  
Mostly by Signal Corps in kits with pliers, assembled by us.

<del>CONTRACTS</del>	-	<u>PRIME CONTRACTS</u>	1940	84,685
			1941	86,263
<del>UPON THE BASIS OF</del>			1942	691,158
			1943	598,963
<del>Other</del>			1944	49,758
			1945	86,100

			1942	26,508
		<u>SUB-CONTRACTS</u>	1943	106,236
			1944	<del>10,140</del>
			1945	55,956

10/27/43

U.S. MARINE CORPS

Govt- TL-29 Electricians  
Knife

Our 57L49

SEE SIGNAL CORPS TL29

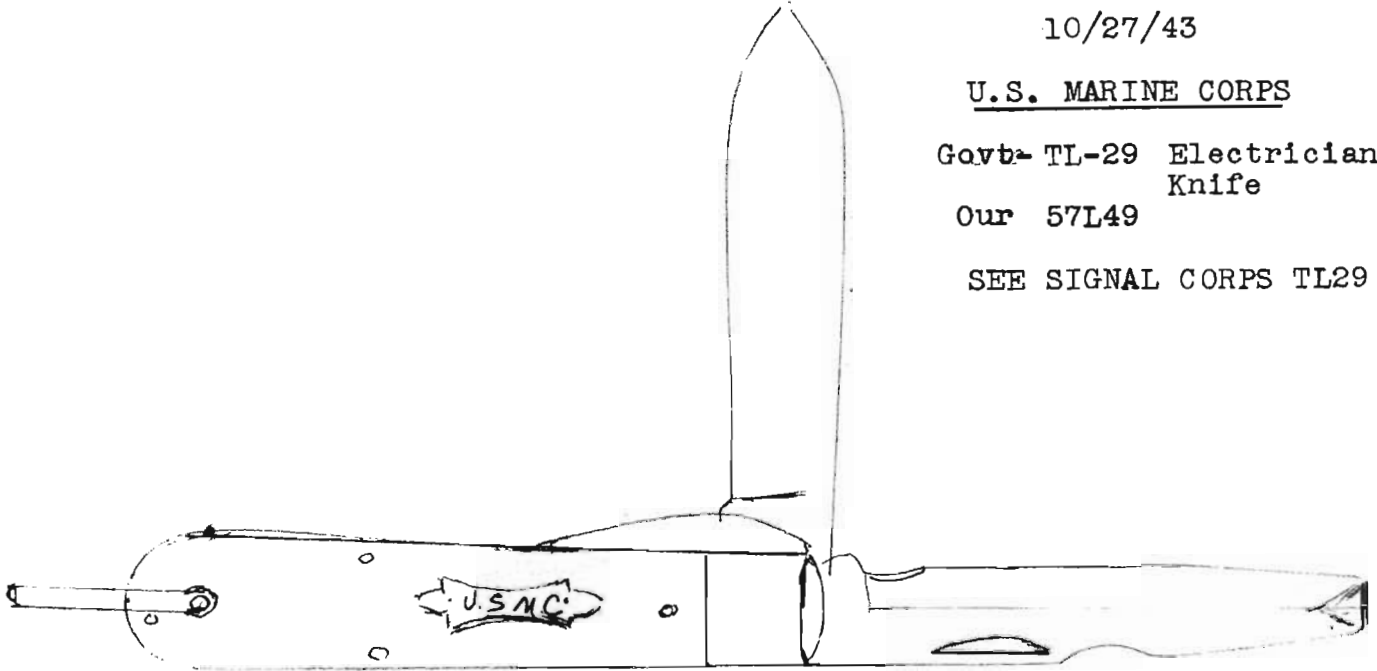

57 I 92

57 L 49 all steel

DESCRIPTION:

57L49 - same as used for Signal Corps but shield reading  
USMC instead of TL29. All steel.

No. 14811 - Jeffersonville Q.M.  
4 blade, Bone stag, brass lined and brass center scale steel bolsters and new long shackle. Bladed spear, old canopener, old screwdr. caplif. and plain punch. Black tangs, springs painted inside, SFAA.

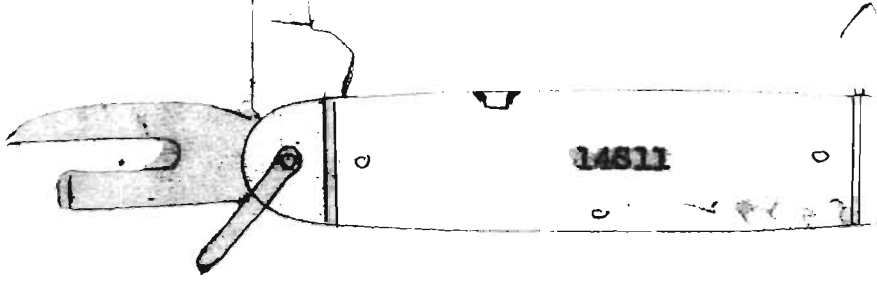

No. 14938 - Navy Dept.  
4 blade Utility Jack, FG stag handle, brass lining and center scale, steel bolsters and new long shackle. Bladed spear, pen, new canopener and long screwdr. caplif. Springs clear inside. SFAA

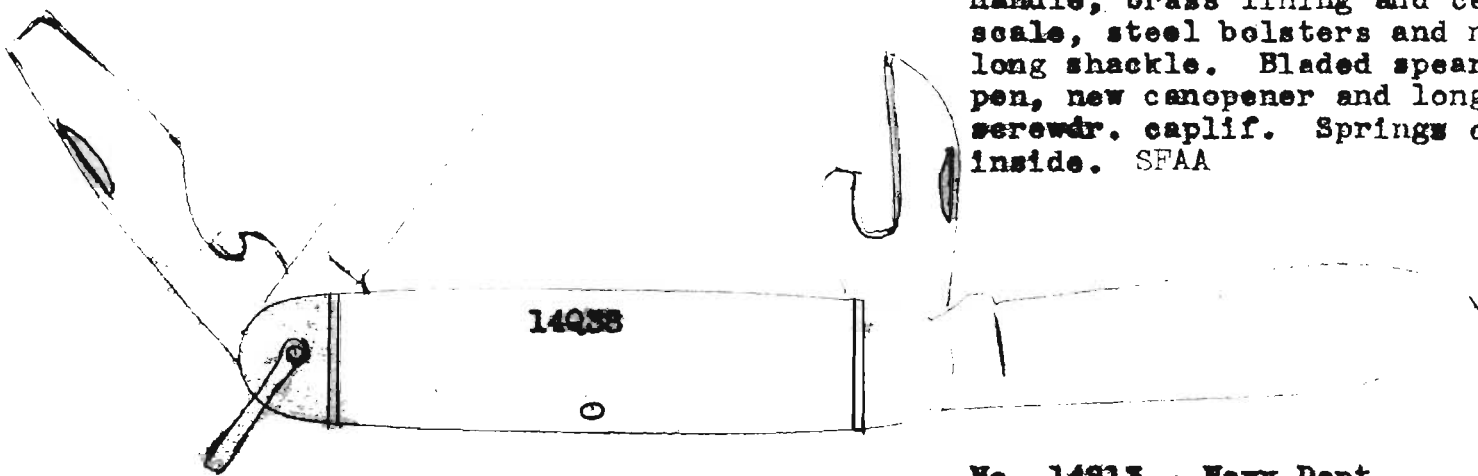

No. 14813 - Navy Dept.  
4 Blade, Utility Jack, FG stag handle, brass lining and center scale, steel bolster and new long shackle. Bladed spear, pen, new canopener and long screwdr. caplif. Black tangs, springs painted inside, SFAA.

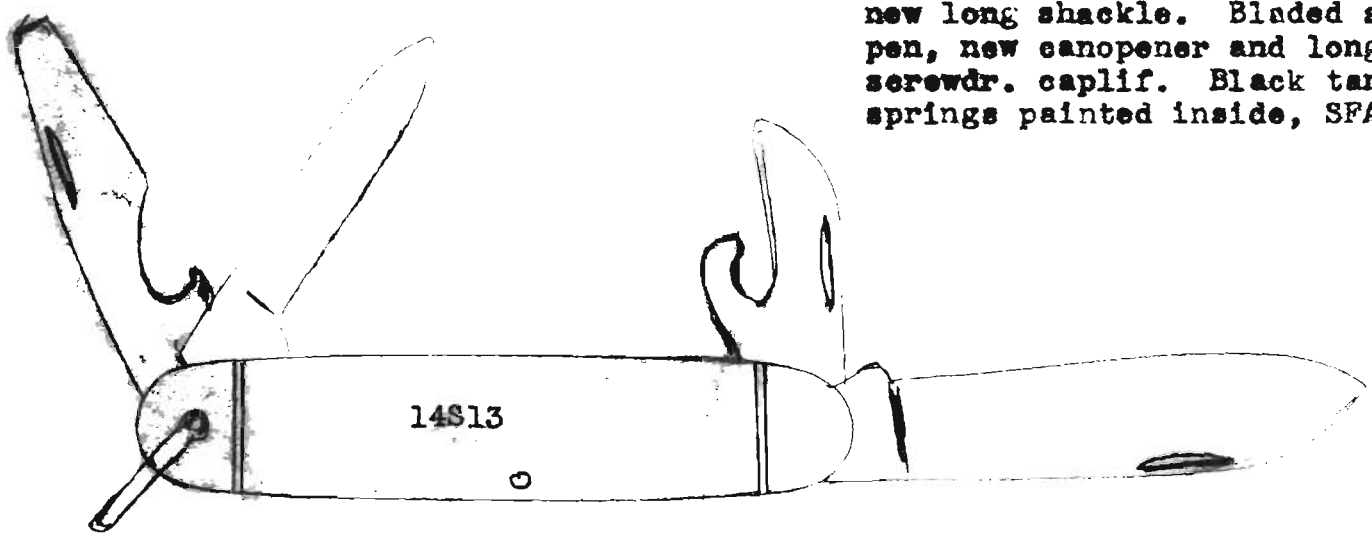

4/1/45

14325 - Quartermaster  
4 blade, FO stag handle,  
brass lining and center  
seals, steel bolsters, new  
long shackle; bladed spear,  
new canopener, long screw-  
driver, caplif, plain  
punch. Springs painted  
inside, black tangs, SP1A.  
(Like S15 but with punch  
instead of pen blade),

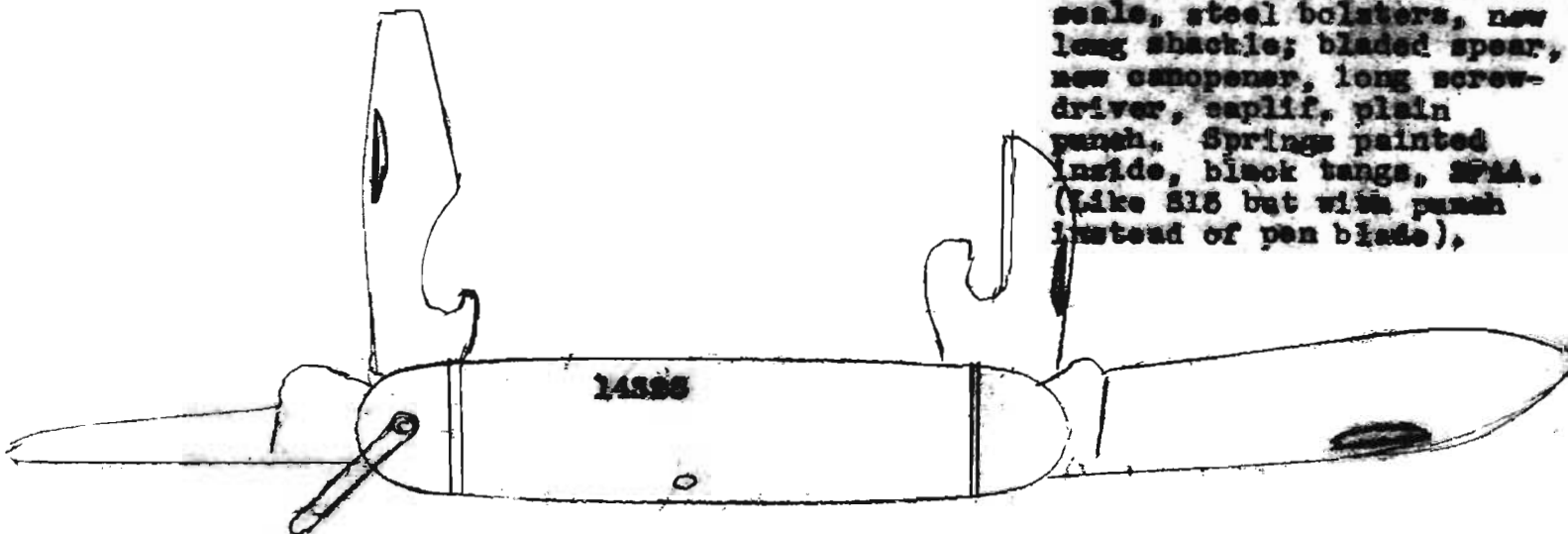

14326 - 4 blade Utility  
Navy Dept.  
Cellulose acetate, new  
solid Tech-Art handle,  
thick bolster, brass lining  
Bladed spear, pen, new  
canopener, long screwdr.  
caplif, Black tangs, spring  
painted inside, SP1A.  
(Same as S13 with TA handle)

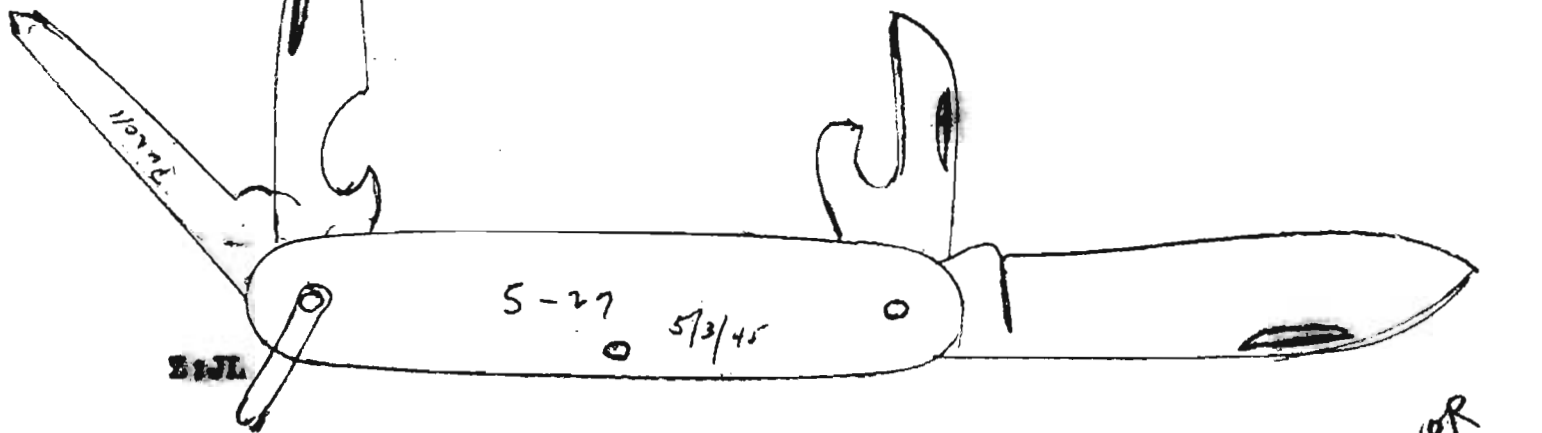
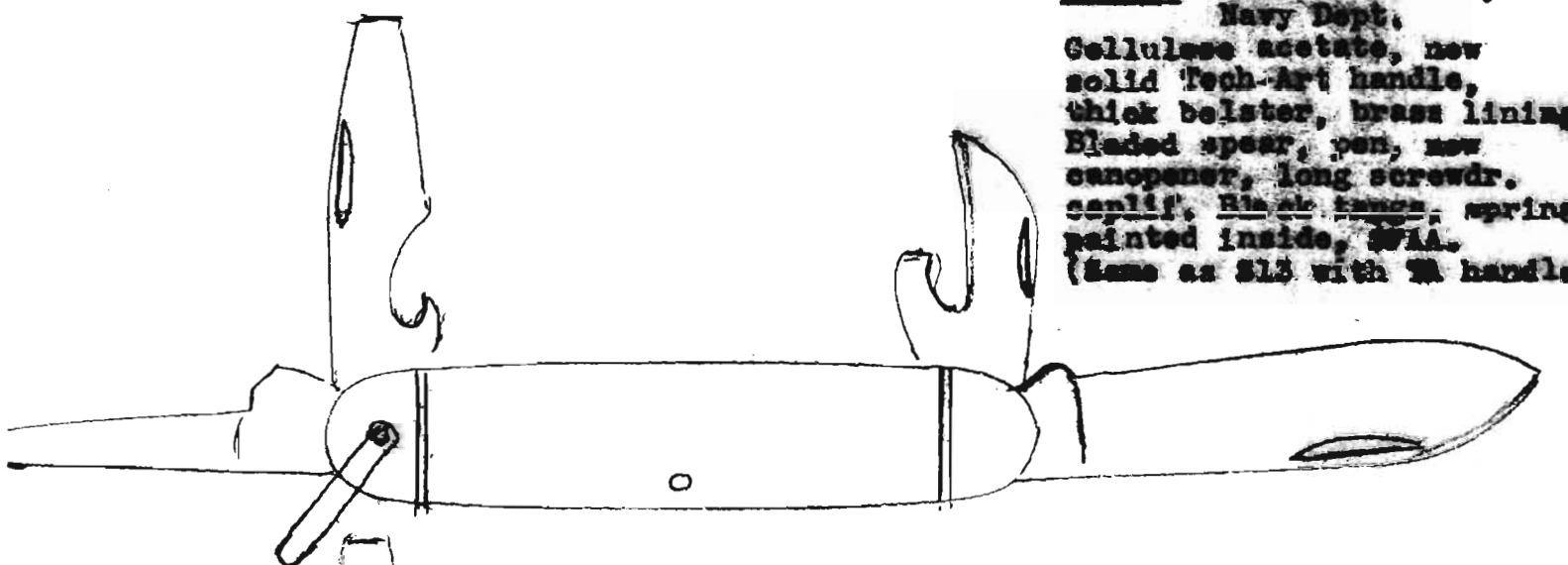

SP1A

over



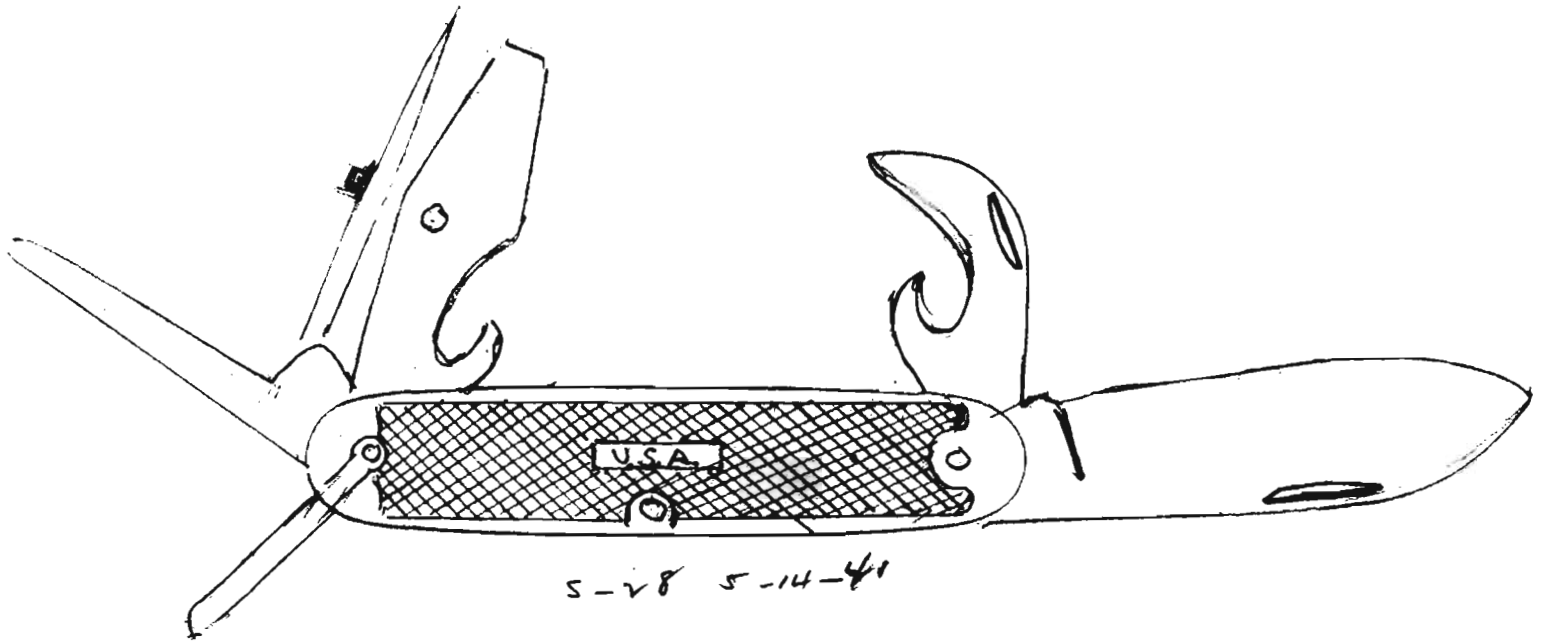

4 blade

**PRIME CONTRACTS:**

1943	23,000 ea.
1944	2,006,121
1945	930,000

Sub-Govt

1944	89,292
1945	32,760.