

# OMRON

## Mobile I/O Box

### User's Manual



I677-E-01

**NOTE**

All rights reserved. No part of this publication may be reproduced, stored in a retrieval system, or transmitted, in any form, or by any means, mechanical, electronic, photocopying, recording, or otherwise, without the prior written permission of OMRON.

No patent liability is assumed with respect to the use of the information contained herein. Moreover, because OMRON is constantly striving to improve its high-quality products, the information contained in this manual is subject to change without notice. Every precaution has been taken in the preparation of this manual. Nevertheless, OMRON assumes no responsibility for errors or omissions. Neither is any liability assumed for damages resulting from the use of the information contained in this publication.

**Trademarks**

Company names and product names in this document are the trademarks or registered trademarks of their respective companies.

**Copyrights**

Microsoft product screen shots reprinted with permission from Microsoft Corporation.

# Introduction

Thank you for purchasing the Mobile I/O Box.

This manual is OMRON's original instructions describing the setup, operations, and user maintenance of the Mobile I/O Box.

Please read this manual and make sure you understand the functionality and performance of the Mobile I/O Box before attempting to use it.

Keep this manual in a safe place where it will be available for reference during operation.

## Intended Audience

This manual is intended for the following personnel, who must also have knowledge of factory automation (FA) systems and robotic control methods.

- Personnel in charge of introducing FA systems.
- Personnel in charge of designing FA systems.
- Personnel in charge of installing and maintaining FA systems.
- Personnel in charge of managing FA systems and facilities.

It is the end-user's responsibility to ensure that all personnel who will work with or around AMRs have attended an appropriate training and have a working knowledge of the system. The user must provide the necessary additional training for all personnel who will be working with the system.

As described in this document, you should allow only skilled persons or instructed persons to do certain procedures. Skilled persons have technical knowledge or sufficient experience to enable them to avoid either electrical or mechanical dangers. Instructed persons are adequately advised or supervised by skilled persons to enable them to avoid either electrical or mechanical dangers.

All personnel must observe industry-prescribed safety practices during the installation, operation, and testing of all electrically-powered equipment.

Before working with the AMR, every person must confirm that they:

- Have the necessary qualifications and training.
- Have access to this document and other safety documentation.
- Have read and understand the related documentation.
- Have agreed work in the manner specified by the documentation.

## Applicable Products

This manual covers following products:

Product	Model
Mobile I/O Box	23419-802

## Units

All units are metric unless otherwise noted.

# Manual Information

## Page Structure

The following page structure is used in this manual.

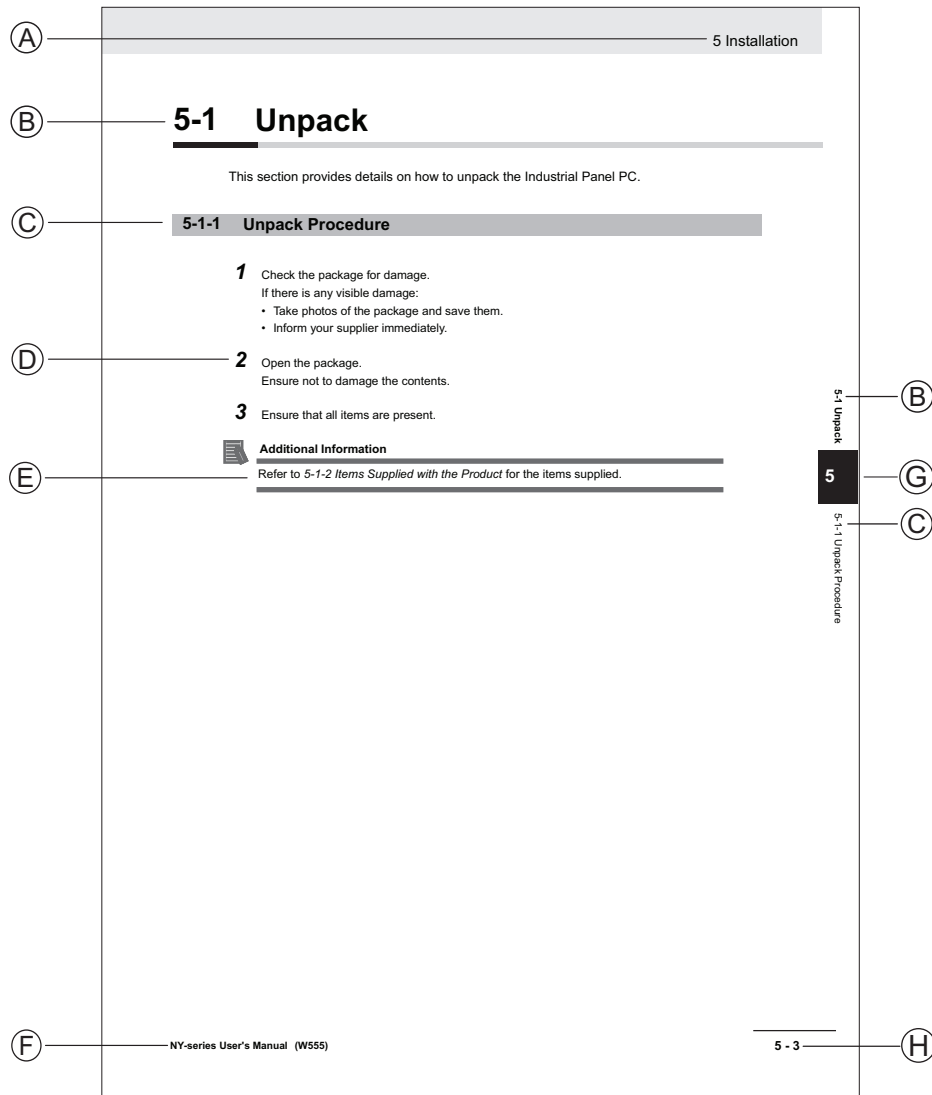

Note: This illustration is provided as a sample. It will not literally appear in this manual.

Item	Explanation	Item	Explanation
A	Level 1 heading	E	Special Information
B	Level 2 heading	F	Manual name
C	Level 3 heading	G	Page tab with the number of the main section
D	Step in a procedure	H	Page number

## Special Information

Special information in this manual is classified as follows:



### **Precautions for Safe Use**

---

Precautions on what to do and what not to do to ensure safe usage of the product.

---



### **Precautions for Correct Use**

---

Precautions on what to do and what not to do to ensure proper operation and performance.

---



### **Additional Information**

---

Additional information to read as required.

This information is provided to increase understanding or make operation easier.

---



### **Version Information**

---

Information on differences in specifications and functionality between different versions.

---



# Sections in this Manual

---

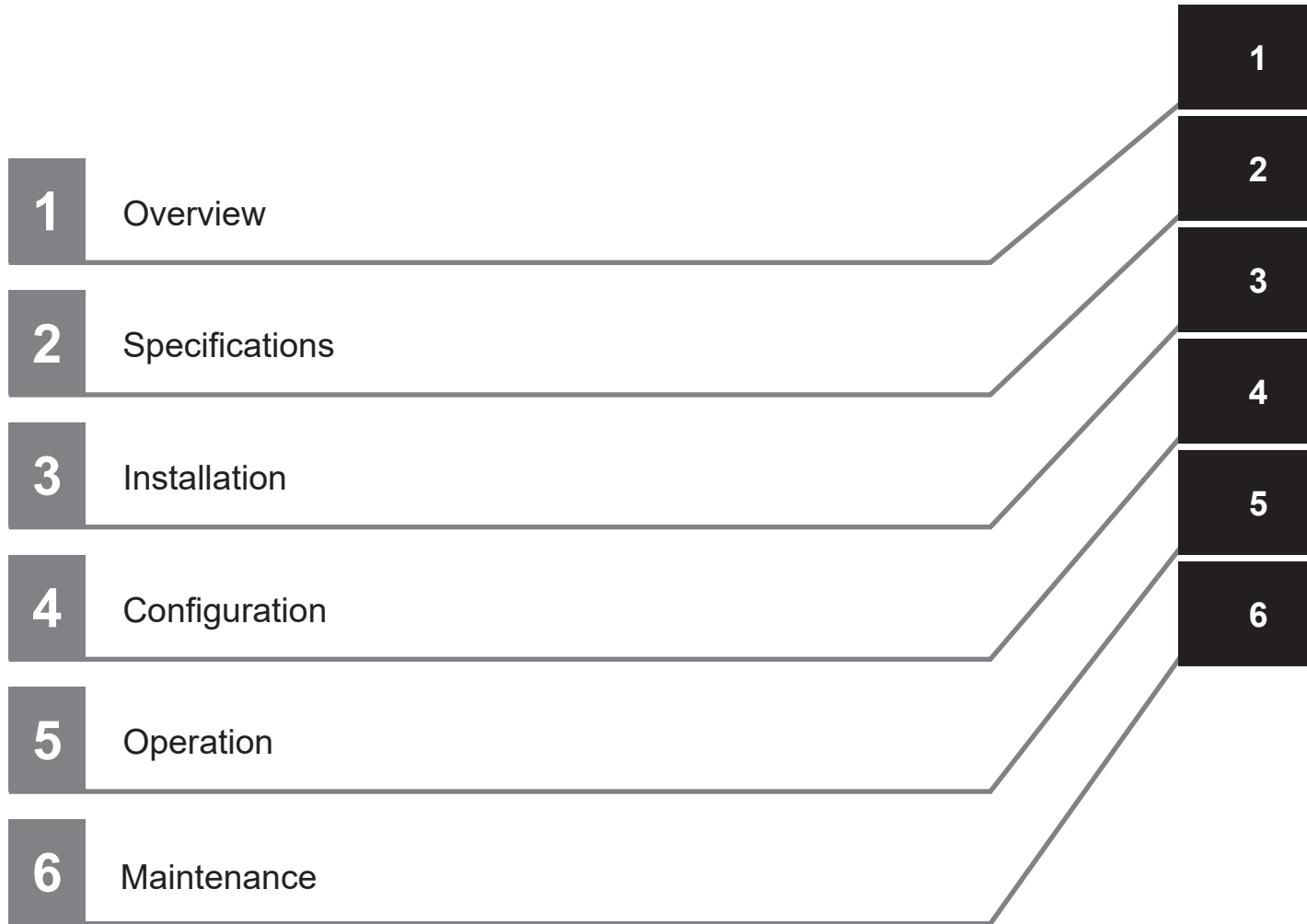

# CONTENTS

---

<b>Introduction .....</b>	<b>1</b>
Intended Audience .....	1
Applicable Products .....	1
Units .....	1
<b>Manual Information .....</b>	<b>2</b>
Page Structure .....	2
Special Information .....	3
<b>Sections in this Manual .....</b>	<b>5</b>
<b>Terms and Conditions Agreement.....</b>	<b>9</b>
Warranty and Limitations of Liability .....	9
Application Considerations .....	10
Disclaimers .....	11
<b>Safety Precautions.....</b>	<b>12</b>
Definition of Precautionary Information.....	12
Symbols .....	12
Warnings.....	13
Cautions.....	15
<b>Precautions for Safe Use .....</b>	<b>16</b>
Disassembly, Dropping, Mounting, Installation and Storage .....	16
Wiring.....	16
Power Supply.....	16
Operation .....	17
Disposal .....	17
<b>Precautions for Correct Use .....</b>	<b>18</b>
Installation.....	18
Operation .....	18
<b>Regulations and Standards .....</b>	<b>19</b>
Conformance to EU Directives .....	19
EN Harmonized Standards .....	19
UL / Canada Standards .....	19
Conformance to KC Certification .....	19
<b>Related Manuals.....</b>	<b>20</b>
<b>Glossary.....</b>	<b>21</b>
<b>Revision History.....</b>	<b>22</b>

## Section 1 Overview

---

<b>1-1 Intended Use .....</b>	<b>1-2</b>
<b>1-2 Product Overview .....</b>	<b>1-3</b>
<b>1-3 Information Label .....</b>	<b>1-4</b>
<b>1-4 Communication.....</b>	<b>1-5</b>
<b>1-5 Functions.....</b>	<b>1-6</b>



1-5-1	Call Function .....	1-6
1-5-2	External Digital I/O .....	1-6

## Section 2 Specifications

<b>2-1</b>	<b>Physical Specifications .....</b>	<b>2-2</b>
2-1-1	Dimensions .....	2-2
2-1-2	Weight .....	2-2
<b>2-2</b>	<b>Environmental Specifications.....</b>	<b>2-3</b>
2-2-1	Recycling Specifications .....	2-3
<b>2-3</b>	<b>Electrical Specifications.....</b>	<b>2-4</b>
2-3-1	Power Consumption Specifications.....	2-4
<b>2-4</b>	<b>Connector Specifications .....</b>	<b>2-5</b>
2-4-1	I/O Connector Specifications.....	2-5
2-4-2	USB Connector Specifications .....	2-9
2-4-3	Ethernet Connector Specifications .....	2-10
2-4-4	RS-232C Connector Specifications.....	2-12
2-4-5	RP-SMA Antenna Connector Specifications .....	2-13
<b>2-5</b>	<b>Display Specifications.....</b>	<b>2-14</b>

## Section 3 Installation

<b>3-1</b>	<b>Installation Procedure .....</b>	<b>3-2</b>
<b>3-2</b>	<b>Unpack.....</b>	<b>3-3</b>
<b>3-3</b>	<b>Mount .....</b>	<b>3-4</b>
<b>3-4</b>	<b>Connect.....</b>	<b>3-5</b>
3-4-1	Power Supply .....	3-6

## Section 4 Configuration

<b>4-1</b>	<b>Configuration Overview .....</b>	<b>4-2</b>
<b>4-2</b>	<b>Required and Recommended Software .....</b>	<b>4-3</b>
4-2-1	SetNetGo .....	4-4
<b>4-3</b>	<b>Configure the Mobile I/O Box.....</b>	<b>4-6</b>
<b>4-4</b>	<b>Configure MobilePlanner .....</b>	<b>4-8</b>
4-4-1	MobilePlanner Configuration Overview .....	4-8
4-4-2	Configure MobileIO .....	4-9
4-4-3	Configure the Call Function.....	4-11
4-4-4	Configure External Digital Outputs.....	4-13
4-4-5	Configure External Digital Inputs.....	4-14
<b>4-5</b>	<b>Verify the Functionality .....</b>	<b>4-15</b>

## Section 5 Operation

<b>5-1</b>	<b>The User Interface.....</b>	<b>5-2</b>
5-1-1	Setup Screens.....	5-5
<b>5-2</b>	<b>Call an AMR.....</b>	<b>5-7</b>
<b>5-3</b>	<b>Cancel an AMR Summon Request .....</b>	<b>5-9</b>

## Section 6 Maintenance

---

<b>6-1</b>	<b>Preventive Maintenance</b> .....	<b>6-2</b>
6-1-1	Preventive Maintenance Schedule .....	6-2
6-1-2	Clean the Mobile I/O Box .....	6-2
6-1-3	Replace the Battery .....	6-3
<b>6-2</b>	<b>Corrective Maintenance</b> .....	<b>6-6</b>
6-2-1	Error Situations .....	6-6
6-2-2	Error States Mobile I/O Box .....	6-7
6-2-3	Error Messages MobilePlanner .....	6-9

## Index

---

# Terms and Conditions Agreement

---

## Warranty and Limitations of Liability

### Warranty

---

- **Exclusive Warranty**

Omron's exclusive warranty is that the Products will be free from defects in materials and workmanship for a period of twelve months from the date of sale by Omron (or such other period expressed in writing by Omron). Omron disclaims all other warranties, expressed or implied.

- **Limitations**

OMRON MAKES NO WARRANTY OR REPRESENTATION, EXPRESS OR IMPLIED, ABOUT NON-INFRINGEMENT, MERCHANTABILITY OR FITNESS FOR A PARTICULAR PURPOSE OF THE PRODUCTS. BUYER ACKNOWLEDGES THAT IT ALONE HAS DETERMINED THAT THE PRODUCTS WILL SUITABLY MEET THE REQUIREMENTS OF THEIR INTENDED USE.

Omron further disclaims all warranties and responsibility of any type for claims or expenses based on infringement by the Products or otherwise of any intellectual property right.

- **Buyer Remedy**

Omron's sole obligation hereunder shall be, at Omron's election, to (i) replace (in the form originally shipped with Buyer responsible for labor charges for removal or replacement thereof) the non-complying Product, (ii) repair the non-complying Product, or (iii) repay or credit Buyer an amount equal to the purchase price of the non-complying Product; provided that in no event shall Omron be responsible for warranty, repair, indemnity or any other claims or expenses regarding the Products unless Omron's analysis confirms that the Products were properly handled, stored, installed and maintained and not subject to contamination, abuse, misuse or inappropriate modification. Return of any Products by Buyer must be approved in writing by Omron before shipment. Omron Companies shall not be liable for the suitability or unsuitability or the results from the use of Products in combination with any electrical or electronic components, circuits, system assemblies or any other materials or substances or environments. Any advice, recommendations or information given orally or in writing, are not to be construed as an amendment or addition to the above warranty.

See <http://www.omron.com/global/> or contact your Omron representative for published information.

### Limitations of Liability

---

OMRON COMPANIES SHALL NOT BE LIABLE FOR SPECIAL, INDIRECT, INCIDENTAL, OR CONSEQUENTIAL DAMAGES, LOSS OF PROFITS OR PRODUCTION OR COMMERCIAL LOSS IN ANY WAY CONNECTED WITH THE PRODUCTS, WHETHER SUCH CLAIM IS BASED IN CONTRACT, WARRANTY, NEGLIGENCE OR STRICT LIABILITY. Further, in no event shall liability of Omron Companies exceed the individual price of the Product on which liability is asserted.

## Application Considerations

### Suitability for Use

---

Omron Companies shall not be responsible for conformity with any standards, codes or regulations which apply to the combination of the Product in the Buyer's application or use of the Product. At Buyer's request, Omron will provide applicable third party certification documents identifying ratings and limitations of use which apply to the Product. This information by itself is not sufficient for a complete determination of the suitability of the Product in combination with the end product, machine, system, or other application or use. Buyer shall be solely responsible for determining appropriateness of the particular Product with respect to Buyer's application, product or system. Buyer shall take application responsibility in all cases.

NEVER USE THE PRODUCT FOR AN APPLICATION INVOLVING SERIOUS RISK TO LIFE OR PROPERTY WITHOUT ENSURING THAT THE SYSTEM AS A WHOLE HAS BEEN DESIGNED TO ADDRESS THE RISKS, AND THAT THE OMRON PRODUCT(S) IS PROPERLY RATED AND INSTALLED FOR THE INTENDED USE WITHIN THE OVERALL EQUIPMENT OR SYSTEM.

### Programmable Products

---

- Omron Companies shall not be responsible for the user's programming of a programmable Product, or any consequence thereof.
- Omron Companies shall not be responsible for the operation of the user accessible operating system (e.g. Windows, Linux), or any consequence thereof.

## Disclaimers

### Performance Data

---

Data presented in Omron Company websites, catalogs and other materials is provided as a guide for the user in determining suitability and does not constitute a warranty. It may represent the result of Omron's test conditions, and the user must correlate it to actual application requirements. Actual performance is subject to the Omron's Warranty and Limitations of Liability.

### Change in Specifications

---

Product specifications and accessories may be changed at any time based on improvements and other reasons. It is our practice to change part numbers when published ratings or features are changed, or when significant construction changes are made. However, some specifications of the Product may be changed without any notice. When in doubt, special part numbers may be assigned to fix or establish key specifications for your application. Please consult with your Omron's representative at any time to confirm actual specifications of purchased Product.

### Errors and Omissions

---



Information presented by Omron Companies has been checked and is believed to be accurate; however, no responsibility is assumed for clerical, typographical or proofreading errors or omissions.

# Safety Precautions





## Definition of Precautionary Information

The following notation is used in this manual to provide precautions required to ensure safe usage of the Mobile I/O Box. The safety precautions that are provided are extremely important to safety. Always read and heed the information provided in all safety precautions.

The following notation is used.

 <b>DANGER</b>	Identifies an imminently hazardous situation which, if not avoided, is likely to result in serious injury, and might result in fatality or severe property damage.
 <b>WARNING</b>	Indicates a potentially hazardous situation which, if not avoided, could result in death or serious injury. Additionally, there may be severe property damage.
 <b>CAUTION</b>	Indicates a potentially hazardous situation which, if not avoided, may result in minor or moderate injury, or property damage.

## Symbols

	The circle and slash symbol indicates operations that you must not do. The specific operation is shown in the circle and explained in text. This example indicates prohibiting disassembly.
	The triangle symbol indicates precautions (including warnings). The specific operation is shown in the triangle and explained in text. This example indicates a precaution for electric shock.
	The triangle symbol indicates precautions (including warnings). The specific operation is shown in the triangle and explained in text. This example indicates a general precaution.
	The filled circle symbol indicates operations that you must do. The specific operation is shown in the circle and explained in text. This example shows a general precaution for something that you must do.
	The triangle symbol indicates precautions (including warnings). The specific operation is shown in the triangle and explained in text. This example indicates a precaution for high temperatures.

## Warnings

### **WARNING**

#### **Disassembly and Dropping**

Do not attempt to disassemble, repair, or modify the product in any way. Doing so may result in malfunction or fire.



#### **Installation**

Ensure that installation and post-installation checks of the product are performed by personnel in charge who possess a thorough understanding of the machinery to be installed.



Unintended access to areas may be granted when Outputs are used to open doors or panels. Provide external safety measures to prevent access to restricted areas.



#### **Fail-safe Measures**

The product will turn OFF all outputs in the following cases:

- If an error occurs in the power supply
- During a firmware upgrade of a host
- If a product error occurs

External safety measures must be provided to ensure safe operation of the system in such cases.



## Cybersecurity

---

To maintain the security and reliability of the system, a robust cybersecurity defense program should be implemented, which may include some or all of the following:

### Anti-virus protection

- Install the latest commercial-quality anti-virus software on the computer connected to the control system and keep the software and virus definitions up-to-date.
- Scan USB drives or other external storage devices before connecting them to control systems and equipment.

### Security measures to prevent unauthorized network access

- Install physical controls so that only authorized personnel can access control systems and equipment.
- Reduce connections to control systems and equipment via networks to prevent access from untrusted devices.
- Install firewalls to block unused communications ports and limit communication between systems. Limit access between control systems and systems from the IT network.
- Control remote access and adopt multifactor authentication to devices with remote access to control systems and equipment.
- Set strong password policies and monitor for compliance frequently.

### Data input and output protection

- Backup data and keep the data up-to-date periodically to prepare for data loss.
- Validate backups and retention policies to cope with unintentional modification of input/output data to control systems and equipment.
- Validate the scope of data protection regularly to accommodate changes.
- Check validity of backups by scheduling test restores to ensure successful recovery from incidents.
- Safety design, such as emergency shutdown and fail-soft operations in case of data tampering and incidents.

### Additional recommendations

- When using an external network environment to connect to an unauthorized terminal such as a SCADA, HMI or to an unauthorized server may result in network security issues such as spoofing and tampering.
  - You must take sufficient measures such as restricting access to the terminal, using a terminal equipped with a secure function, and locking the installation area by yourself.
  - When constructing network infrastructure, communication failure may occur due to cable disconnection or the influence of unauthorized network equipment.
  - Take adequate measures, such as restricting physical access to network devices, by means such as locking the installation area.
  - When using devices equipped with an SD Memory Card, there is a security risk that a third party may acquire, alter, or replace the files and data in the removable media by removing or unmounting the media.
  - Please take sufficient measures, such as restricting physical access to the Controller or taking appropriate management measures for removable media, by means of locking and controlling access to the installation area.
  - Educate employees to help them identify phishing scams received via email on systems that will connect to the control network.
- 





## Cautions

### CAUTION

#### Operation

---

The following actions are required for safe use of the I/O Box.

- Make sure that the environment is suitable for safe operation of the I/O Box.
  - Mechanically maintain and service the I/O Box for proper operation of all control and safety functions.
- 



# Precautions for Safe Use

## Disassembly, Dropping, Mounting, Installation and Storage

- Do not drop the product or subject it to abnormal vibration or shock. Doing so may result in product malfunction or burning.
- When unpacking, check carefully for any external scratches or other damages. Also, shake the product gently and check for any abnormal sound.
- Always use the devices specified in the relevant manual.
- Install the product in the correct orientation and temperature according to the specifications in the manual to prevent overheating. Not doing so may result in malfunction.
- When connecting peripheral devices to the product, ensure sufficient countermeasures against noise and static electricity during installation of the peripheral devices.
- Do not operate or store the product in the following locations. Operation may stop or malfunctions may occur.
  - Locations subject to direct sunlight
  - Locations subject to temperatures or humidity outside the range specified in the specifications
  - Locations subject to condensation as the result of severe changes in temperature
  - Locations subject to corrosive or flammable gases
  - Locations subject to dust (especially iron dust) or salts
  - Locations subject to exposure to water, oil or chemicals
  - Locations subject to shock or vibration
  - Locations outdoors subject to direct wind and rain
  - Locations subject to strong ultraviolet light

## Wiring

- Follow the instructions in the manual to correctly perform connector wiring and insertion. Double-check all wiring and connector insertion before turning ON the power supply.
- Do not bend or pull the cables beyond normal limit. Do not place heavy objects on top of the cables or other wiring lines. Doing so may break the cables.
- Be sure that all mounting bracket screws and cable connector screws are tightened to the torque specified in the relevant manuals. The loose screws may result in fire or malfunction.
- Use crimp terminals for wiring.

## Power Supply

- Ensure the Mobile I/O Box is powered by an approved certified AC power adaptor that complies to the required electrical specifications.
- Always check the power supply and power connections before applying power. Incorrect power connections can damage the product or cause burning.
- Always turn OFF the power supply to system before you attempt any of the following:
  - Connecting cables
  - Connecting or disconnecting the connectors
  - Wiring the system

## Operation

- The following actions are strictly prohibited and could result in injury or damage to the equipment.
  - Operating in environments with life support systems.
  - Operating in residential areas.
  - Operating on non-stationary areas, including moving floors or any type of land vehicle, watercraft, or aircraft.
  - Using unauthorized parts to repair the I/O Box.
  - Operating the I/O Box in hazardous environments where there is explosive gas, an oil mist, or a corrosive atmosphere.
- Any modifications made to the I/O Box can lead to loss of safety or functionality of the I/O Box. It is the end-user's responsibility to perform complete risk assessment after making any modifications to the I/O Box, and to confirm that all safety features of the I/O Box are fully functional.
- It is the end-user's responsibility to perform a task-based risk assessment and to implement appropriate safety measures at the point of use of the I/O Box in accordance with local regulations.
- It is the end-user's responsibility to make sure that the I/O Box design and implementation complies with all local standards and legal requirements.
- It is the end-user's responsibility to make sure that the I/O Box is operated within its specifications, intended use, and intended environments.
- The following actions are required for safe use of the I/O Box.
  - Review and understand the safety protections associated with your specific application and environment.
  - Make sure that any person working with or near a Mobile I/O Box is trained and has read and understands this document.

## Disposal

- Dispose of the product and batteries according to local ordinances as they apply.



廢電池請回收

- Dispose in accordance with applicable regulations.



- Customers can contribute to resource conservation and protecting the environment by the proper disposal of WEEE (Waste Electronics and Electrical Equipment). All electrical and electronic products should be disposed of separately from the municipal waste system via designated collection facilities. For information about disposal of your old equipment, contact your local OMRON representative.

# Precautions for Correct Use

---

## Installation

- Take appropriate and sufficient countermeasures when installing the product in the following locations
  - Locations subject to strong, high-frequency noise
  - Locations subject to static electricity or other forms of noise
  - Locations subject to strong electromagnetic fields
  - Locations subject to possible exposure to radioactivity
  - Locations close to power lines
- Before you configure WiFi on your Mobile I/O Box, contact your network administrator to confirm the IP, radio, and security settings.
- When using WiFi, check the signal strength. The position of the antenna is critical to correct operation.

## Operation

Ensure that available software checks are performed by personnel in charge who possess a thorough understanding of the software.

# Regulations and Standards

## Conformance to EU Directives

The Mobile I/O box complies with the following EU Directives:

- 2006/42/EC  
Machinery Directive
- 2014/30/EU  
EMC Directive
- 2014/53/EU  
RED Directive

## EN Harmonized Standards

The I/O Box conforms to the following EN standards:

- EN ISO 12100  
Safety of Machinery. General Principles for Design. Risk Assessment and Reduction.
- EN 301 489 -17  
EMC, Standard for radio equipment, Part 17: Specific conditions for Broadband Data Transmission Systems.
- EN 301 328 v2.2.2  
EMC, Standard for wideband transmission systems: Data transmission equipment operating in the 2.4GHz band; Harmonized Standard for access to radio spectrum.

## UL / Canada Standards

The I/O Box conforms to the following UL / Canada standards:

- UL 61010 Standard for Electrical Equipment for Measurement, Control, and Laboratory Use; Part 1: General Requirements
- CAN/CSA C22.2. NO. 61010. Standard for Safety requirements for electrical equipment for measurement, control, and laboratory use - Part 1: General requirements

## Conformance to KC Certification

When you use this product in South Korea, observe the following precautions.

<b>사 용 자 안 내 문</b>
이 기기는 업무용 환경에서 사용할 목적으로 적합성평가를 받은 기기로서 가정용 환경에서 사용하는 경우 전파간섭의 우려가 있습니다.

This product meets the electromagnetic compatibility requirements for business use.

# Related Manuals

---

Use the following related manuals for reference.

Manual Title	Description
LD-250 Platform User's Manual (Cat. No. I642)	Describes the installation, start-up, operation, and maintenance of the LD-250 AMR.
HD-1500 Platform User's Manual (Cat. No. I645)	Contains information necessary to install, operate, maintain and troubleshoot HD-1500 AMRs.
HD Mobile Robot Safety Manual (Cat. No. I647)	Contains general safety information for HD-1500 AMRs.
Fleet Operations Workspace Core User's Manual (Cat. No. I635)	Describes Fleet management, MobilePlanner software, the SetNetGo OS, and most of the configuration procedures for an AMR.
Enterprise Manager 2100 User's Guide (Cat. No. I631)	Describes the installation of an EM2100 appliance, which runs the Fleet Operations Workspace software to manage a fleet of AMRs.

# Glossary

Term / Abbreviation	Description
AMR	This term is used to refer to an Autonomous Mobile Robot.
AMR Controller	The AMR's main computing system that provides all navigational controls and application interfaces.
Ethernet	A type of network used in local area networks that typically uses a twisted pair cable and supports data speeds up to 1 Gbps.
FA	Factory Automation
Fleet	Two or more AMRs operating in the same workspace controlled by a single Fleet Manager.
Fleet Manager	The operational mode of the computing appliance (EM2100) that runs the FLOW Core software to control a fleet of AMRs.
Fleet Operations Workspace (FLOW)	A computing system that consists of software and hardware packages and is used to set up, integrate, and manage a fleet of AMRs within a factory environment.
Goal	A map-defined virtual destination for mobile robots (e.g., pickup or dropoff points).
I/O	Input and output signals that are transmitted to and from a device.
IP	Internet protocol that provides a set of communication standards for transmitting data between networked devices. An IP address is used as a device's unique network identifier.
Job	An activity typically consisting of one or two segments that instruct the AMR to drive to a goal for material pickup or dropoff.
LAN	Local Area Network
LED	A light emitting diode that illuminates to provide a visual indication of some operation.
MAC	Media Access Control – identifies an individual electronic device on a network.
Map	A representation of the AMR's environment within MobilePlanner that it uses for navigation.
MobilePlanner	The primary software application for programming AMR actions. It provides the tools for all major AMR activities, such as observing a fleet of AMRs, commanding individual AMRs to drive, creating and editing map files, goals, and tasks, and modifying AMR configurations.
Pendant	A handheld, external input device for manually driving an AMR. Connects to the AMR's pendant (or joystick) connection port. In this manual, pendant can mean either pendant (for HD AMRs) or joystick (for LD-series AMRs). The two devices are similar, but not interchangeable.
Pickup	A job segment where an AMR typically acquires a payload.
Skilled persons	Persons that have the technical knowledge or sufficient experience to enable them to avoid electrical or mechanical dangers.
SSID	Service Set Identification – identifies a wireless LAN.
Tasks	Instructions for the AMR to perform certain actions like reading inputs, setting outputs, movement commands, talking, waiting and other functions.
Troubleshooting	Efforts such as information collection, diagnostics, and error recovery to resume normal operation.
WLAN	Wireless Local Area Network
Workspace	The intended operating area of the AMR.

# Revision History

---

A manual revision code appears as a suffix to the catalog number on the front and back covers of the manual.

<b>Cat. No.</b>	<b>I677-E-01</b>
-----------------	------------------

↑  
Revision code

Revision code	Date	Revised content
01	February 2023	First release



# 1

## Overview

This section provides an overview of the Mobile I/O Box.

---

<b>1-1</b>	<b>Intended Use</b> .....	<b>1-2</b>
<b>1-2</b>	<b>Product Overview</b> .....	<b>1-3</b>
<b>1-3</b>	<b>Information Label</b> .....	<b>1-4</b>
<b>1-4</b>	<b>Communication</b> .....	<b>1-5</b>
<b>1-5</b>	<b>Functions</b> .....	<b>1-6</b>
1-5-1	Call Function .....	1-6
1-5-2	External Digital I/O .....	1-6

# 1-1 Intended Use

---

The Mobile I/O Box can be used to:

1. Summon an AMR to a goal with the Call Function.
2. Use External Digital I/O for control of connected devices. These can be associated with AMR related actions like opening a door for an AMR.

The Mobile I/O Box is intended to be part of an environment with AMRs controlled by a Fleet Manager. Refer to *Related Manuals* on page 20 for more information.

The Mobile I/O Box is designed to work in an indoor, industrial environment, and in the presence of trained personnel. This includes structured or semi-structured workplaces such as warehouses, distribution, and logistics facilities where general public access is restricted. You must deploy it only in applications where you anticipate and mitigate potential risks to personnel and equipment.

The Mobile I/O Box is not intended to be used in the following environments.

- Outdoor or uncontrolled areas without risk analysis.
- Areas with general public access.
- Areas with life-support systems.
- Residential areas.

## 1-2 Product Overview

This section provides an overview of the basic features and components of the Mobile I/O Box.

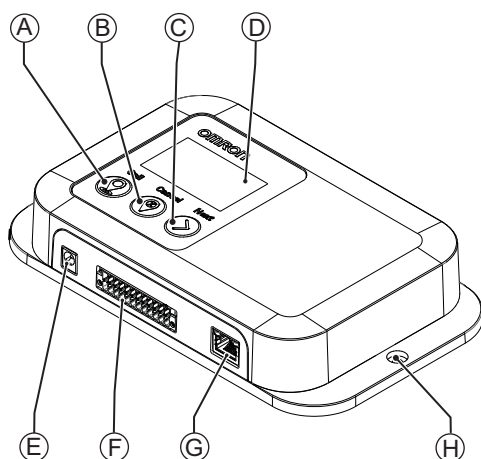

Front and bottomside

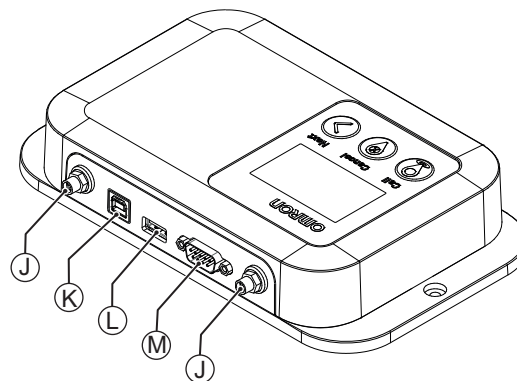

Topside

Item	Description	Function	Details
A	Call Button	Request an AMR User Interface action <b>Enter</b>	<i>Section 5 Operation</i> on page 5-1
B	Cancel Button	Cancel an AMR User Interface action <b>Cancel</b>	
C	Next Button	User Interface actions <ul style="list-style-type: none"> <li>• Normal press (&lt;0.75 s) = <b>Next</b></li> <li>• Long press (&gt;0.75 s) = <b>Back</b></li> </ul>	
D	LCD Screen	Display of the User Interface	<i>Section 5 Operation</i> on page 5-1 <i>2-5 Display Specifications</i> on page 2-14
E	Power Supply Connection	Power supply	<i>3-4-1 Power Supply</i> on page 3-6
F	I/O Ports	Communication with external hardware	<i>2-4-1 I/O Connector Specifications</i> on page 2-5
G	Ethernet Port	<ul style="list-style-type: none"> <li>• Connection to a LAN</li> <li>• Configuration of the Mobile I/O Box</li> <li>• Communication with a Fleet Manager or an AMR</li> </ul>	<i>2-4-3 Ethernet Connector Specifications</i> on page 2-10
H	Wall Mounting Hole	Secure the unit to a surface	<i>3-3 Mount</i> on page 3-4
J	RP-SMA Antenna Connectors	<ul style="list-style-type: none"> <li>• Connection to a WLAN</li> <li>• Communication with a Fleet Manager or an AMR</li> </ul>	<i>2-4-5 RP-SMA Antenna Connector Specifications</i> on page 2-13
K	USB-B Port	Reserved for future use	<i>2-4-2 USB Connector Specifications</i> on page 2-9
L	USB-A Port		
M	RS232-C Serial Ports		

## 1-3 Information Label

The information labels contain relevant information about the Mobile I/O Box. The following examples may be different from your product label.

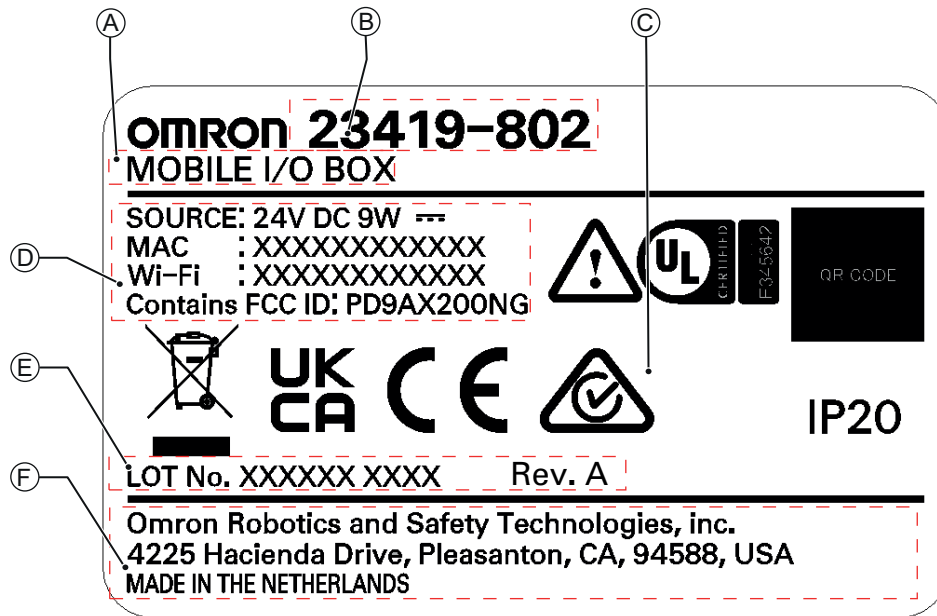

Item	Name	Description
A	Product Type	The product type
B	Part Number	The Mobile I/O Box part number
C	Alerts and Compliance	General alerts and compliance information
D	Mobile I/O Box Information	General information about the Mobile I/O Box
E	Lot Number and Revision	Lot. No. indicates the lot number in the format of DDMMYYFF. Month number 1 to 9 for January to September, X for October, Y for November, and Z for December. Rev. indicates the product revision.
F	Product Origin Information	Product origin information is provided.

# 1-4 Communication

---

The Mobile I/O Box will communicate with the environment.

The communication can be with:

- a Fleet Manager, using WiFi or wired Ethernet
- an AMR, using WiFi for normal operations



## Additional Information

---

- The Mobile I/O Box communicates with SetNetGo. SetNetGo will be installed on an AMR but it is mostly used within MobilePlanner, Fleet Manager or Enterprise Manager.
  - Call Boxes and this Mobile I/O Box can be used simultaneously with the most recent version of FLOW software.
  - A router or access point is allowed as an extra step in the communication.
  - A Call for an AMR cannot be used when an AMR is in Patrol Route mode.
- 

Inputs and Outputs can communicate with the environment.

A typical example is an input detecting a door status and an output being able to open/close the door.

# 1-5 Functions

The Mobile I/O Box can perform two functions simultaneously:

1. Summon an AMR to a goal  
Refer to *1-5-1 Call Function* on page 1-6 for details.
2. Use External Digital Inputs and Outputs  
Refer to *1-5-2 External Digital I/O* on page 1-6 for details.

## 1-5-1 Call Function

The Mobile I/O Box can summon an AMR to a goal.

The functionality to request on AMR is referred to as Call Function.

One goal can be selected for each Mobile I/O Box.

There are 2 procedures to set a goal:

1. With Fleet Manager to select a goal using the MobileIO parameters.  
Refer to *Goal Configuration With Fleet Manager* on page 4-12 for more information.
2. Without Fleet Manager using a joy-stick combined with a scan of the environment.  
Refer to *Goal Configuration Without Fleet Manager* on page 4-12 for more information.



### Additional Information

- The Fleet Manager supports the simultaneous use of up to 40 Mobile I/O Boxes.
- A call for an AMR cannot be used when an AMR is in Patrol Route mode.
- Refer to *4-4-3 Configure the Call Function* on page 4-11 for more information.
- Refer to *5-2 Call an AMR* on page 5-7 for more information.

## 1-5-2 External Digital I/O

The Mobile I/O Box can be configured to work with external digital I/O. E.g. a digital Output can activate a door to open for an AMR.

In the Fleet Manager MobileIO parameters a goal can be selected for each Mobile I/O Box.

Refer to *4-4-2 Configure MobileIO* on page 4-9 for more information.



### Additional Information

- The External Digital I/O can be contact inputs, optocouplers and relays.  
Refer to *2-4-1 I/O Connector Specifications* on page 2-5 for more information.
- Refer to *4-4-4 Configure External Digital Outputs* on page 4-13 for more information.
- Refer to *4-4-5 Configure External Digital Inputs* on page 4-14 for more information.

# 2

## Specifications

This section provides the specifications for the Mobile I/O Box.

---

<b>2-1</b>	<b>Physical Specifications .....</b>	<b>2-2</b>
2-1-1	Dimensions.....	2-2
2-1-2	Weight .....	2-2
<b>2-2</b>	<b>Environmental Specifications .....</b>	<b>2-3</b>
2-2-1	Recycling Specifications.....	2-3
<b>2-3</b>	<b>Electrical Specifications .....</b>	<b>2-4</b>
2-3-1	Power Consumption Specifications.....	2-4
<b>2-4</b>	<b>Connector Specifications .....</b>	<b>2-5</b>
2-4-1	I/O Connector Specifications.....	2-5
2-4-2	USB Connector Specifications .....	2-9
2-4-3	Ethernet Connector Specifications .....	2-10
2-4-4	RS-232C Connector Specifications.....	2-12
2-4-5	RP-SMA Antenna Connector Specifications .....	2-13
<b>2-5</b>	<b>Display Specifications .....</b>	<b>2-14</b>

## 2-1 Physical Specifications

Physical specification of the Mobile I/O Box are provided below.

### 2-1-1 Dimensions

Physical dimensions of the Mobile I/O Box are provided below.

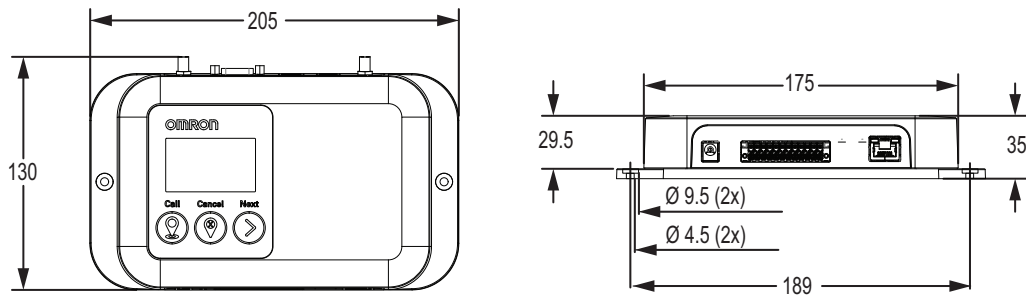

### 2-1-2 Weight

Weights for the Mobile I/O Box are provided in the following table.

Item	Weight
Mobile I/O Box	0.50 kg
Mobile I/O Box with packaging	0.85 kg



## 2-2 Environmental Specifications

Environmental specifications are provided below.

Item	Specification
Ambient operating temperature	0 to 40° C
Storage temperature	-20 to 60° C
Humidity	Up to 40°C: 90%RH; 40 – 60°C: 90 – 30%RH (Non-condensing) During storage and transportation: 75% or less (non-condensing)
Special Hazards	No corrosive gasses
Altitude	2000 m max.
Pollution degree	2
Degree of protection	IP20

### 2-2-1 Recycling Specifications

The following table provides recycling information for the Mobile I/O Box.

Part	Recycle specifications
Battery	Chemical waste
Other electrical components	Electrical waste



#### Precautions for Safe Use



廢電池請回收

Dispose of the product and batteries according to local ordinances as they apply.



Dispose in accordance with applicable regulations.

Customers can contribute to resource conservation and protecting the environment by the proper disposal of WEEE (Waste Electronics and Electrical Equipment). All electrical and electronic products should be disposed of separately from the municipal waste system via designated collection facilities. For information about disposal of your old equipment, contact your local OMRON representative.

## 2-3 Electrical Specifications

Electrical Specifications are provided below.

Item	Specification
Supply voltage	12 to 24 VDC
Operating voltage range	10.8 to 28.8 VDC (-10% to +20%)
Power Consumption	9 W max.
Isolation	None
Protection	Reverse power, over current (resettable)
Grounding method	No grounding method supplied
Connector	Barrel jack, 5.5 x 2.5 mm (inner pin positive)

### 2-3-1 Power Consumption Specifications

The total power consumption for the Mobile I/O Box is the sum of the power consumption of all installed components.

The power consumption Mobile I/O Box:

Mobile I/O Box	Power consumption
Complete	9 W



#### Additional Information

Ensure to use a power supply with sufficient capacity.  
Refer to *3-4-1 Power Supply* on page 3-6 for more information.

## 2-4 Connector Specifications

This section provides the connector specifications of the Mobile I/O Box.

### 2-4-1 I/O Connector Specifications

Details of the I/O connector are provided below.

Lock the I/O connector when inserted to prevent unintentional disconnection.

The connector can only be inserted in the correct way.

#### I/O Connector

The I/O connector on the I/O Box provides Input and Output signals.

The I/O connector is supplied with the I/O Box

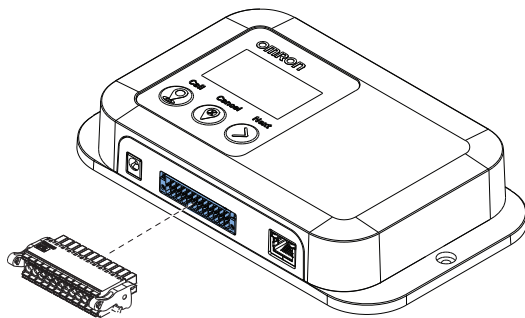

#### Additional Information

Refer to *I/O Connector Pin Details* on page 2-7 for more information.

Refer to *I/O Connector Wiring Materials* on page 2-8 for more information.

#### ● Connectors

Details for the recommended connectors are provided below.

OMRON is not responsible for the operation or performance of any other connector.

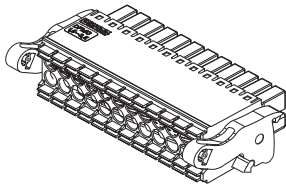
Model	Appearance	Specifications
DFMC 1,5/ 12-ST-3,5-LR BK (1711130), Phoenix Contact		I/O Connector for OMRON Mobile I/O Box 1 piece.

## Lock and Remove the I/O Connector

The I/O connector locks into place when the black part of the connector is held and pushed in.

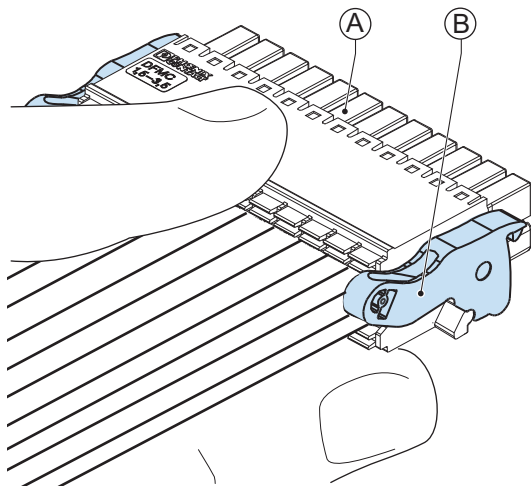

Tilting both levers **(B)** will release the I/O connector **(A)** from the I/O Box.

## I/O Connector Pin Details

The pin details of the I/O connector.

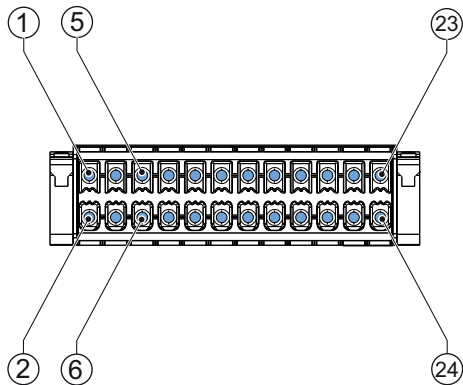

The pin layout represents the I/O connector on the I/O Box.

The I/O signals connected must be powered from a power supply which conforms to the SELV standards.

Pin details of the I/O Connector:

Pin ID	1	3	5	7	9	11	13	15	17	19	21	23
Description	IN0	IN1	IN2	IN3	IN4	IN5	OUT0	OUT1	OUT2	OUT3	OUT4	OUT5
Description	CI0	CI1	CI2	CI3	CI4	CI5	CO0	CO1	CO2	CO3	CO4	CO5
Pin ID	2	4	6	8	10	12	14	16	18	20	22	24

Pin	Description	Type	Electrical Specifications	Details
1,3	IN0, IN1	Contact input	<ul style="list-style-type: none"> <li>ON: 5 mA</li> <li>OFF: 0.5 mA</li> <li>Non-isolated</li> </ul>	<ul style="list-style-type: none"> <li>Internally powered</li> <li>Pin 2 and 4, CI0 and CI1 are internally connected to the 0V of the power-supply input.</li> </ul>

Pin	Description	Type	Electrical Specifications	Details
5, 7, 9, 11	IN2 ... IN5	Optocouplers	<ul style="list-style-type: none"> <li>• ON: 8.8 VDC min./5 mA min.</li> <li>• OFF: 1.1 VDC max./0.5 mA max.</li> <li>• Isolation 500V between outputs and system</li> </ul>	
13, 15, 17, 19, 21, 23	OUT0 ... OUT5	Relay SPST- NO	<ul style="list-style-type: none"> <li>• 24 VDC, 2A resistive load</li> <li>• Isolation 500V between outputs and system</li> <li>• Lifetime 100,000 cycles at 2A max.</li> </ul>	<p>Switch capacity 24 VDC, 2A resistive load</p>



**Additional Information**

Refer to *I/O Connector Wiring Materials* on page 2-8 for more information.

## I/O Connector Wiring Materials

Use the supplied I/O connector to connect the inputs and outputs to the Mobile I/O Box. Recommended I/O conductor sizes for the connector are provided in the table.

Wire type	Conductor cross-section
Solid conductor	0.2 to 1.5 mm <sup>2</sup>
Flexible conductor	
Flexible conductor, with ferrule and no plastic sleeve	0.25 to 1.5 mm <sup>2</sup>
Flexible conductor, with ferrule and plastic sleeve	0.25 to 0.75 mm <sup>2</sup>
Minimum AWG according to UL/cUL	24
Maximum AWG according to UL/cUL	16

## 2-4-2 USB Connector Specifications

The Mobile I/O Box includes several USB connectors.



### Additional Information

USB-A and USB-B connectors are reserved for future use.

## USB Connectors

For future use there are 2 USB connectors on the I/O Box.

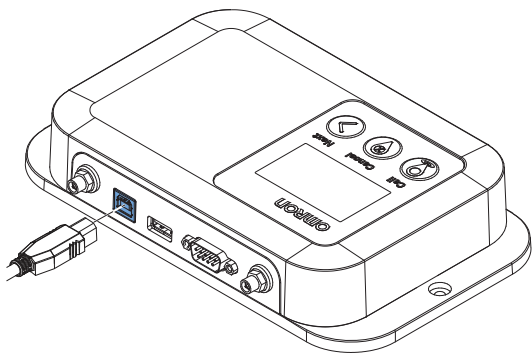

USB-B connector

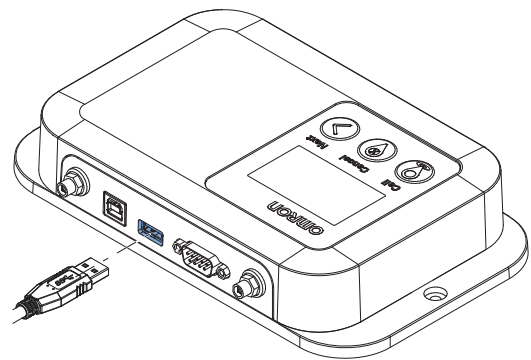

USB-A connector

### 2-4-3 Ethernet Connector Specifications

Details of the RJ45 Ethernet connectors are provided below.

The Ethernet connector locks automatically to prevent unintentional disconnection.

#### Ethernet Connector

The Ethernet connector is locked when inserted to prevent unintentional disconnection.

The connector can only be inserted in the correct way.

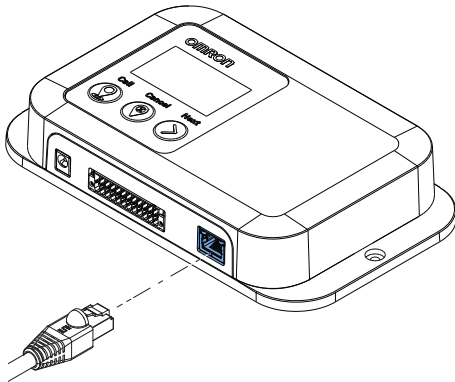

#### Ethernet Connector Specification Details

Details of the RJ45 Ethernet connectors are provided below.

Item	Specifications
Physical layer	10BASE-T, 100BASE-TX or 1000BASE-T
Frame length	1,514 bytes max.
Media access method	CSMA/CD
Modulation	Baseband
Topology	Star
Transmission media	STP (shielded, twisted pair) cable of Ethernet category 5,5e or higher
Maximum transmission distance between Ethernet switch and node	100 m
Cascade connections	There are no restrictions if an Ethernet switch is used



## Ethernet Connector LED Indicators

This section explains the RJ45 Ethernet connector LED indicators.

Each connector has LED indicators that display the link, activity and speed status.

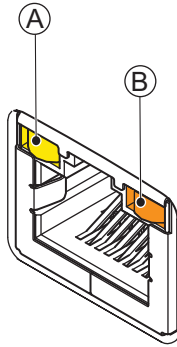

Item	Indicator	Color	Status		Description
A	Link/Act	Yellow		Not lit	No link
				Lit	Link
				Flashing	Link and activity
B	Speed	Not lit		Not lit	10 Mbps or no link
		Green		Lit	100 Mbps link
		Orange		Lit	1 Gbps link

## 2-4-4 RS-232C Connector Specifications

The Mobile I/O Box has one RS232 Serial port.



### Additional Information

The RS-232C connector is reserved for future use.

## RS-232C Connector

The RS-232C connector on the I/O Box uses a standard SUBD9 connector.  
The RS-232C interface is not isolated from the internal I/O Box components.

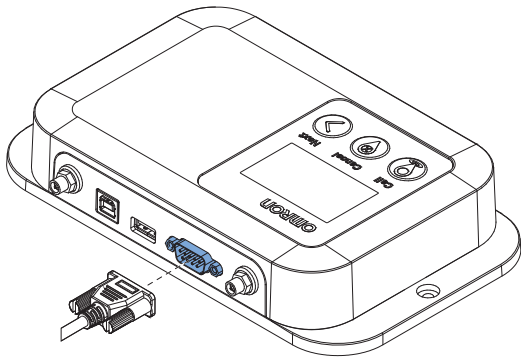

## 2-4-5 RP-SMA Antenna Connector Specifications

The Mobile I/O Box includes 2 connectors for RP-SMA Antennas.

Two Reverse Polarity SMA antennas are provided with the Mobile I/O Box.

Interface	Specification	Details
RP-SMA Male connector, inside thread, female central receptacle	Frequency band coverage	2.4G, 5G
	WiFi standards	<ul style="list-style-type: none"> <li>• Wi-Fi 6 (802.11ax)</li> <li>• Wi-Fi 802.11a, b, g, n, ac</li> </ul>
	Signal emission	360 degrees omni-directional
	Length of each antenna	10.8cm
	Type	2J Antennas, 2JW1102 -C943B
	Part Number 23419-100F	ID for a set of two antennas



### Additional Information

The antenna positioning influences the signal quality.

## RP-SMA Antenna Connectors

The 2 connectors for an RP-SMA Antenna.

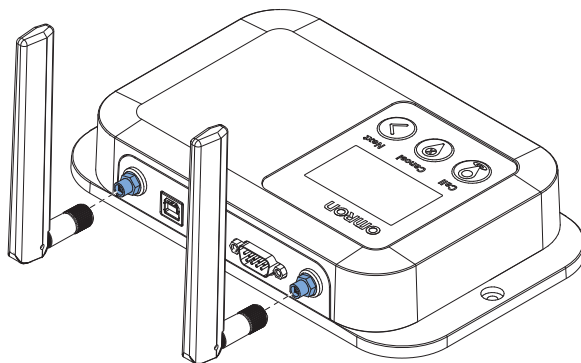

## 2-5 Display Specifications

---

The Mobile I/O Box contains a display screen for interaction with the user. The specifications for this display are listed below.

Item	Specification
Screen type	LCD, FSTN negative
Backlight color	White
Backlight technology	LED
Backlight control	Dimmable
Backlight lifetime	100,000 hours at 25°C
Text color	White
Resolution	128 x 64 pixels
Effective display area	47.99 mm x 27.83 mm

# 3

## Installation

This section provides information about installing the Mobile I/O Box.

---

<b>3-1</b>	<b>Installation Procedure .....</b>	<b>3-2</b>
<b>3-2</b>	<b>Unpack .....</b>	<b>3-3</b>
<b>3-3</b>	<b>Mount.....</b>	<b>3-4</b>
<b>3-4</b>	<b>Connect.....</b>	<b>3-5</b>
3-4-1	Power Supply .....	3-6

## 3-1 Installation Procedure

---

The following procedure provides details about installing the Mobile I/O Box.

- 1** Remove the Unit from its packaging.  
Refer to *3-2 Unpack* on page 3-3 for more information.
- 2** Mount the I/O Box.  
Refer to *3-3 Mount* on page 3-4 for more information.
- 3** Wire and connect the I/O Box.  
Refer to *3-4 Connect* on page 3-5 for more information.
- 4** Configure the Mobile I/O Box and the related environment.  
Refer to *Section 4 Configuration* on page 4-1 for more information.

The Mobile I/O Box is installed.

## 3-2 Unpack

To unpack the Mobile I/O Box:

- 1** Check the package for damage.  
If there is any visible damage:
  - Take photos of the package and save them.
  - Inform your supplier immediately.
- 2** Open the package.  
Ensure not to damage the contents.
- 3** Ensure that all items are present.  
The items supplied:
  - The Mobile I/O Box
  - 4 Rubber feet
  - 2 Antennas
  - 1 I/O Connector
  - 1 RJ45 Dust-plug
  - 1 Safety Precaution Sheet

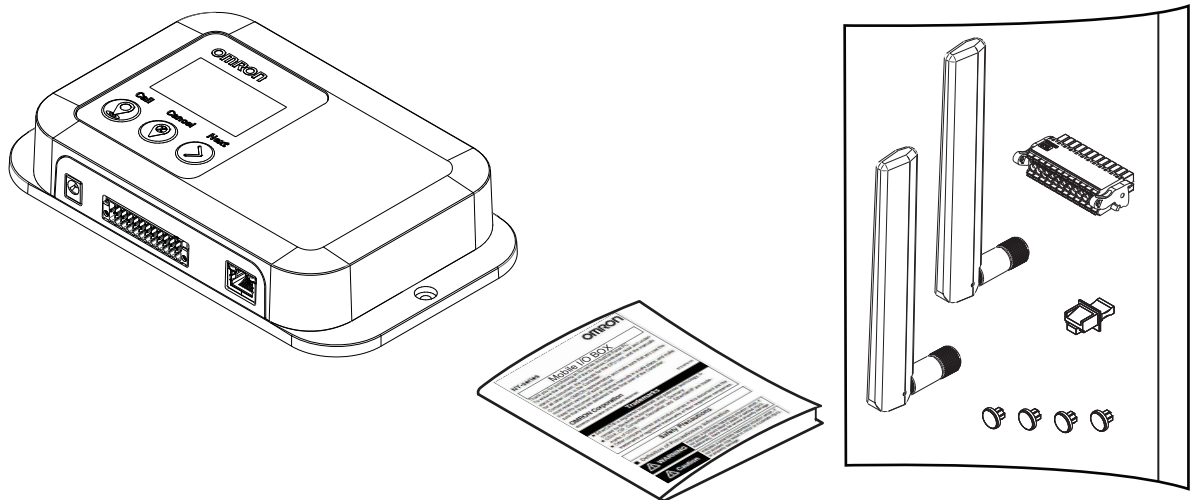

### Additional Information

A power supply is not included.  
Refer to 3-4-1 *Power Supply* on page 3-6 for more information.

## 3-3 Mount

---

The Mobile I/O Box can be wall mounted or placed on a horizontal surface without securing.

The following tools and items are required for this procedure.

- Four M4 or #8 Screws (user-supplied)
- Torque wrench
- Four rubber feet (horizontal placement)

Fasten the Mobile I/O Box directly to the mounting surface using M4 or #8 screws. Screws are not included in the delivery.

Tighten the screws evenly to a torque of 0.6 Nm.

The Mobile I/O Box can be placed on a horizontal flat surface without fixation.

If the Mobile I/O Box is placed on a horizontal surface without fasteners, mount the four rubber feet by pressing them inside the holes at the backside of the Mobile I/O Box.



## 3-4 Connect

---

Connect all required connectors and antennas.

- 1** Remove the dust covers.
- 2** Connect the antennas and/or the Ethernet connector.
  - Rotate the bottom part of the antenna clockwise to connect it hand tightened to the Mobile I/O Box.  
Refer to *2-4-5 RP-SMA Antenna Connector Specifications* on page 2-13 for more information.
  - Insert the Ethernet connector and ensure it is locked.  
Refer to *2-4-3 Ethernet Connector Specifications* on page 2-10 for more information.
- 3** Make all necessary wire connections to the I/O connector and then insert the connector into the I/O Box.
  - Refer to *2-4-1 I/O Connector Specifications* on page 2-5 for more information.
  - Refer to *Lock and Remove the I/O Connector* on page 2-6 for more information.
- 4** Connect the power connector.  
Insert the barrel connector.  
Refer to *3-4-1 Power Supply* on page 3-6 for more information.
- 5** Remove the thin protective plastic sheet that covers the display.

The Mobile I/O Box is connected and ready for configuration.

### 3-4-1 Power Supply

A power supply for the Mobile I/O Box is available as a separate OMRON product.

If a power supply with KCC certification is required contact your local OMRON representative.

OMRON is not responsible for the operation or performance of any other third party power supply.

OMRON Part number	Appearance	Specifications
23419-812		Input voltage: 100 - 240 VAC Output voltage: 24 VDC Output current: 500 mA Connector: Barrel jack Cable length: 1.83 m Adapters: <ul style="list-style-type: none"> <li>• EURO (type C)</li> <li>• USA/JPN (type A)</li> <li>• UK (type G)</li> <li>• AUS/CHN (type I)</li> </ul> Standards: IEC protection Class II, cULus



#### Additional Information

Refer to 2-3-1 *Power Consumption Specifications* on page 2-4 for more information.

# 4

## Configuration

This section provides information about the configuration of the Mobile I/O Box and MobilePlanner.

4

---

<b>4-1</b>	<b>Configuration Overview</b> .....	<b>4-2</b>
<b>4-2</b>	<b>Required and Recommended Software</b> .....	<b>4-3</b>
4-2-1	SetNetGo.....	4-4
<b>4-3</b>	<b>Configure the Mobile I/O Box</b> .....	<b>4-6</b>
<b>4-4</b>	<b>Configure MobilePlanner</b> .....	<b>4-8</b>
4-4-1	MobilePlanner Configuration Overview .....	4-8
4-4-2	Configure MobileIO .....	4-9
4-4-3	Configure the Call Function .....	4-11
4-4-4	Configure External Digital Outputs.....	4-13
4-4-5	Configure External Digital Inputs.....	4-14
<b>4-5</b>	<b>Verify the Functionality</b> .....	<b>4-15</b>

# 4-1 Configuration Overview

---

The configuration for the Mobile I/O Box consists of several steps.

Make the following considerations before beginning this procedure:

- Determine if the Mobile I/O Box host is a Fleet Manager or an AMR.
- Determine the following IP configuration items:
  - Static or dynamic IP address.
  - The IP address of the host.
  - Determine the subnetmask.
  - For a static IP address, the IP address to use.
- Determine the goal locations if using the Call Function.
- Determine the digital I/O that will be used.

Use the following procedure to configure the Mobile I/O Box:

- 1** Ensure the required software is installed and active.  
Refer to *4-2 Required and Recommended Software* on page 4-3 for more information.
- 2** Configure the Mobile I/O Box.  
This will enable communication between the Mobile I/O Box and the host.  
Refer to *4-3 Configure the Mobile I/O Box* on page 4-6 for more information.
- 3** Configure the MobilePlanner software.  
Refer to *4-4 Configure MobilePlanner* on page 4-8 for more information on
  - *4-4-2 Configure MobileIO* on page 4-9
  - *4-4-3 Configure the Call Function* on page 4-11
  - *4-4-4 Configure External Digital Outputs* on page 4-13
  - *4-4-5 Configure External Digital Inputs* on page 4-14
- 4** Check the complete configuration.  
Refer to *4-5 Verify the Functionality* on page 4-15 for more information.

The configuration of the Mobile I/O Box and MobilePlanner is completed.

## 4-2 Required and Recommended Software

Following software is required for the Mobile I/O Box:

- **Internet Browser**

A browser is required to download and upload software and to display a User Interface.

- **SetNetGo**

SetNetGo is required to install the MobileIO package.

SetNetGo is the Operating System on a host related to the Mobile I/O Box. The Mobile I/O Box will connect to a SetNetGo instance.

The Mobile I/O Box can connect to SetNetGo in the Fleet Manager or to SetNetGo installed on an AMR.

Refer to *Fleet Operations Workspace Core User's Manual (Cat. No. I635)* for more information.

Refer to 4-2-1 *SetNetGo* on page 4-4 for more information.

Refer to *SetNetGo - MobileIO* on page 4-5 for more information.

- **MobilePlanner**

MobilePlanner is required as the overall control software for configuration and monitoring.

- **MobileIO SNG package**

The MobileIO SNG package is a component in SetNetGo that communicates with the Mobile I/O Box. It is required to set a goal and to link digital I/O to the Mobile I/O Box.

Refer to *SetNetGo - MobileIO* on page 4-5 for more information.

The following software is recommended for the Mobile I/O Box:

- **Fleet Manager**

A component in the MobilePlanner that will be available for most applications with more than one AMR.

Using the Fleet Manager is not required if there is only a single AMR.

## 4-2-1 SetNetGo

SetNetGo is the operating system available on the Fleet Manager and on the AMR. The SetNetGo interface is used for configuring the Ethernet settings for the platform, upgrading software, and performing systems diagnostics, such as retrieving log files. It can be accessed using an Ethernet port, or via wireless Ethernet if enabled.

Refer to *Fleet Operations Workspace Core User's Manual (Cat. No. I635)* for more information.

The Mobile I/O Box will communicate using SetNetGo.

In SetNetGo the software package **MobileIO** must be installed to use a Mobile I/O Box. This MobileIO software provides the parameters that are specific for your I/O Box.

To check if SetNetGo is configured for the Mobile I/O Box:

- 1 Open **SetNetGo**.
- 2 Select the tab **Software** and then in the left column **Manage Installed Software**. The Manage Installed Software screen will appear.



- 3 Browse the installed software.  
If MobileIO is not visible in the list of installed software then install MobileIO.  
Refer to *SetNetGo - MobileIO* on page 4-5 for more information.

SetNetGo is available and functional and the required MobileIO package is installed.

## SetNetGo - MobileIO

The **MobileIO** software package must be installed in SetNetGo before using the Mobile I/O Box. The MobileIO software provides the parameters that are specific for your I/O Box.

Use the following procedure to install and activate the MobileIO software package:

- 1 Ensure FLOW Core version 3.1 or higher is installed.  
FLOW Core software with a version below 3.1 does not have the MobileIO software package available.  
Update FLOW Core if required. Refer to *Fleet Operations Workspace Core User's Manual* (Cat. No. I635) for more information.
- 2 In SetNetGo select **Choose File** and select the downloaded MobileIO file.

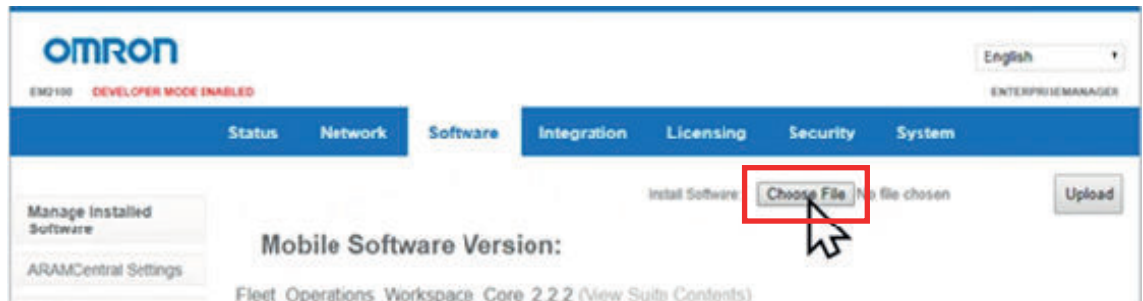

- 3 Select the **Upload** button.  
The MobileIO package will become visible in SetNetGo.
- 4 Select the buttons **Enable** and **Restart** in the MobileIO window.  
The button texts will change to **Disable** and **Restart**.



- 5 Confirm the MobileIO state is **Running**.  
The state is displayed at the end of the topline.

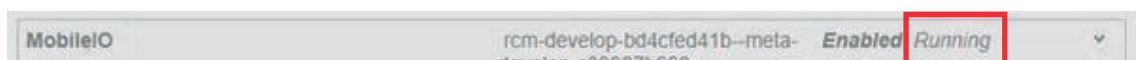

The MobileIO software package is installed and active.

## 4-3 Configure the Mobile I/O Box

Configure the Mobile I/O Box to enable communication with a host. The display and buttons on the Mobile I/O Box are used to configure the Mobile I/O Box as described below.

Use the following procedure to configure the Mobile I/O Box:

- 1 Select the **Next** button to browse to the screen *Setup Menu*.  
Refer to 5-1-1 *Setup Screens* on page 5-5 for more information.

- 2 Select the **Call** button.  
The *Setup Menu* will appear with the selection arrow at the first entry.

```
Setup Menu
->Network setup
  Language select
  Exit setup
```

- 3 With the arrow at *Network setup* select **Call**.  
The *Network setup* screen will appear.

```
Network Setup:
-> Host Address
  eth0 IP Setup
  wlan0 IP Setup
  Default Gateway
  Webserver
```

- 4 Select **Call** at *Host Address* to configure this address. If the host is an Enterprise Manager then use the Fleet IP address for this parameter.
  - Select **Call** to increment the active digit.  
Select **Next** to select the next digit.  
After the last digit **Next** will automatically save the entry and exit.
  - Select **Cancel** to return to the previous menu.
- 5 Select *eth0 IP info* and then select **Call** to configure:
  - DHCP for dynamic assignment of the IP Address.
  - STATIC to manually input the IP Address.  
The required fields are:
    - IP address
    - IP netmask
  - Select **Call** to increment the active digit.  
Select **Next** to select the next digit.  
After the last digit **Next** will automatically save the entry and exit.



- Select **Cancel** to return to the previous menu.

**6** Select *wlan0 IP info* and then select **Call** to configure:

- Select **Call** to increment the active digit.  
Select **Next** to select the next digit.  
After the last digit **Next** will automatically save the entry and exit.
- Select **Cancel** to return to the previous menu.

**7** Select *Default Gateway* and then select **Call** to configure the address:

- Select **Call** to increment the active digit.  
Select **Next** to select the next digit.  
After the last digit **Next** will automatically save the entry and exit.
- Select **Cancel** to return to the previous menu.

**8** Select *Webserver* and then select **Call** to toggle the enabled / disabled status.

The Mobile I/O Box configuration is completed.

## 4-4 Configure MobilePlanner

Use the following information to configure MobilePlanner for use with the Mobile I/O Box.

### 4-4-1 MobilePlanner Configuration Overview

Use the following procedures to configure the MobilePlanner:

- 1** Connect to MobilePlanner.  
Create a new connection in SetNetGo.  
Login with the correct User Name and Password and enter the IP address of the server.

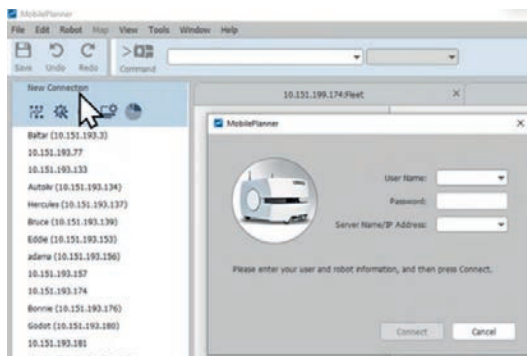

- 2** Configure the Call Function if applicable.  
Refer to *4-4-3 Configure the Call Function* on page 4-11 for more information.
- 3** Configure the MobileIO if applicable.  
Refer to *4-4-2 Configure MobileIO* on page 4-9 for more information.
- 4** Configure the External Digital Outputs if applicable.  
Refer to *4-4-4 Configure External Digital Outputs* on page 4-13 for more information.
- 5** Configure the External Digital Inputs if applicable.  
Refer to *4-4-5 Configure External Digital Inputs* on page 4-14 for more information.
- 6** Check the complete MobilePlanner configuration.  
Refer to *4-5 Verify the Functionality* on page 4-15 for more information.

The MobilePlanner configuration is completed.

## 4-4-2 Configure MobileIO

The configuration procedure for the MobileIO configuration for the Mobile I/O Box in MobilePlanner.

Use the following procedure to configure the Call Function of the Mobile I/O Box using MobilePlanner:

### 1 Configure the global beep parameters.

The beep configuration is in MobilePlanner in the Configuration Tab in the section *MobileIO*

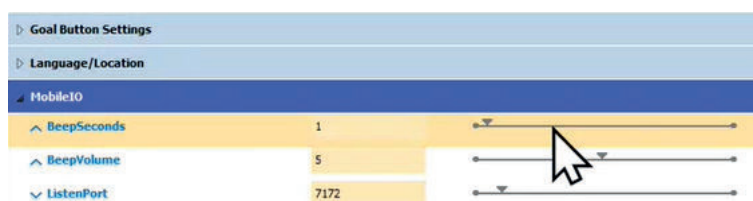

#### Note

This configuration applies to all Mobile I/O Boxes available in the Fleet Manager.

### 2 Configure the Mobile I/O Box specific parameters.

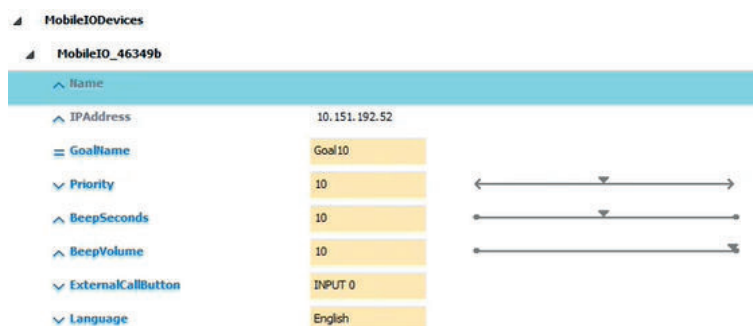

Fields that are auto-populated or do not apply will be greyed out, and you will not be able to change them.

- **Name**

Modify the default name to a logical name.

The default name is the MAC address of the interface card in the Mobile I/O Box.

In the Mobile I/O Box menus this number can be found in the **Eth0 IP Info** or in the **Wlan0 IP Info** screen.

- **IPAddress**

Enter the IP address that you assigned to the Mobile I/O Box.

- **GoalName**

Enter the name of the associated goal.

- **Priority**

Enter the priority to assign to the associated goal. This field will only be visible if the Show Expert + Parameters box is checked.

This is an integer value that represents the priority of the pickup request. The higher the number, the sooner the Fleet Manager will service the request. The default priority is 10. The range is -2147483648 to 2147483647..

- **BeepSeconds**

Configure this if to modify the BeepSeconds to a different value than the default BeepSeconds setting.

- 0: the Call Function will not beep at all.
- -1: the Call Function will beep continuously while the AMR is in the arrived state.
- n: where n is a positive number.

The Call Function will beep for n seconds when the AMR arrives.

The default value is  $n = 1$ .

- **BeepVolume**

Modify the BeepVolume to a value different from the default BeepVolume setting.

- **ExternalCallButton**

Select one of the inputs to function as an external call button.

Note that only one goal can be assigned to the Mobile I/O Box. The ExternalCallButton input will call an AMR to the same goal as the standard **Call** button.

- **Language**

For future use.

The MobilePlanner MobileIO configuration is completed.

### 4-4-3 Configure the Call Function

The Call Function sends an AMR to a specified goal. The configuration of the Call Function consists of the configuration of a goal and assigning that goal to the Mobile I/O Box.

There are two different situations for MobilePlanner and therefore also two different procedures to configure and assign a goal:

1. MobilePlanner can be active on a Fleet Manager.  
Refer to *Goal Configuration With Fleet Manager* on page 4-12 for more information.
2. MobilePlanner can be active on an AMR without a Fleet Manager present.  
Refer to *Goal Configuration Without Fleet Manager* on page 4-12 for more information.

The MobilePlanner Call Function configuration is completed.

## Goal Configuration With Fleet Manager

---

Use the following information for goal configuration using MobilePlanner running on a Fleet Manager. Refer to *Fleet Operations Workspace Core User's Manual (Cat. No. I635)* for more information.

A general overview of the procedure is:

- 1** Open MobilePlanner
- 2** Add goals to the map.  
Refer to *Fleet Operations Workspace Core User's Manual (Cat. No. I635)* for more information.
- 3** Check if the goal is set correctly.  
In MobilePlanner double-click the created goal. The AMR will go to the set location.

The goal configuration for the MobilePlanner Call Function is completed using Fleet Manager.

## Goal Configuration Without Fleet Manager

---

Use the following information for goal configuration using MobilePlanner on an AMR.

Refer to *Fleet Operations Workspace Core User's Manual (Cat. No. I635)* for more information.

A general overview of the procedure is:

- 1** Connect a Pendant (Joystick) to the AMR for manually driving.
- 2** Start the scanning software of MobilePlanner on the AMR.
- 3** Drive the AMR to the goal location.
- 4** Add a goal to the current location of the AMR.

The goal configuration for the MobilePlanner Call Function is completed on the AMR.

## 4-4-4 Configure External Digital Outputs

Use the following procedure to configure the external Digital Outputs of the Mobile I/O Box using MobilePlanner:

- 1 Open the External Digital Outputs section in MobilePlanner.

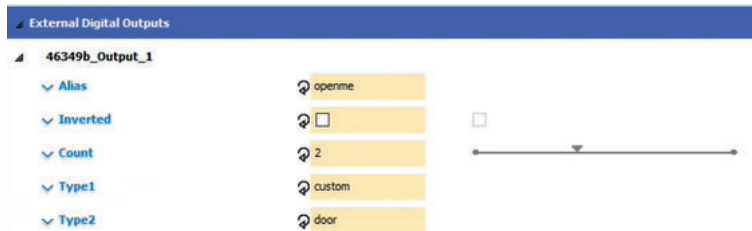

The top level is the name of the Mobile I/O Box.

Refer to *4-4-2 Configure MobileIO* on page 4-9 for more information.

- 2 Configure:

- **Alias**
- **Inverted**
- **Count**
- **Type1**
- **Type2**

For configuration details use the additional information that is visible when an option is selected.

Refer to *Fleet Operations Workspace Core User's Manual (Cat. No. I635)* for more information.

- 3 Ensure activating the specified output is safe.



### Precautions for Safe Use

The specified output will be activated and if not selected correctly this might cause a dangerous situation. Test activating the output before operating the Mobile I/O Box.



### Additional Information

- To monitor the status of DIO in MobilePlanner use Type Custom.
- In FleetManager or in the Map screen use the **Monitor** button in the right bottom corner and the select **Digital I/O** to view the status of the DIO of the MIOB.

The MobilePlanner External Digital Outputs configuration is completed.

## 4-4-5 Configure External Digital Inputs

Use the following procedure to configure the external Digital Inputs of the Mobile I/O Box using MobilePlanner:

- 1 Open the External Digital Inputs section in MobilePlanner.

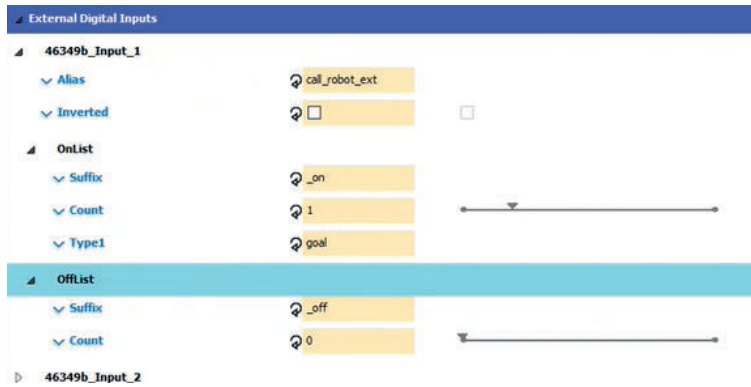

The top level is the name of the Mobile I/O Box.

Refer to *4-4-2 Configure MobileI/O* on page 4-9 for more information.

- 2 Configure:

- **Alias**
- **Inverted**
- OnList - **Suffix**
- OnList - **Count**
- OnList - **Type1**
- OffList - **Suffix**
- OffList - **Count**

For configuration details use the additional information that is visible when an option is selected.

Refer to *Fleet Operations Workspace Core User's Manual (Cat. No. I635)* for more information.

The MobilePlanner External Digital Inputs configuration is completed.



## 4-5 Verify the Functionality

---

This functional verification will confirm the installation and configuration where successful and the Mobile I/O Box can be used for the intended operations.

Use the following procedure to verify the functionality of the Mobile I/O Box:

- 1** Check Outputs.  
Compare the status of each output in Mobile Planner with the status of these outputs in the Mobile I/O Box. The statuses should be identical.
- 2** Check Inputs.  
Compare the status of each input (e.g. sensor) with the status of these inputs in the Mobile I/O Box. The statuses should be identical.
- 3** Check if the name of the goal appears if the **Call** button is activated.  
Refer to *4-4-4 Configure External Digital Outputs* on page 4-13 for details.

The functionality is verified.





# Operation

This section provides information necessary to operate the Mobile I/O Box.

---

<b>5-1</b>	<b>The User Interface .....</b>	<b>5-2</b>
5-1-1	Setup Screens .....	5-5
<b>5-2</b>	<b>Call an AMR .....</b>	<b>5-7</b>
<b>5-3</b>	<b>Cancel an AMR Summon Request .....</b>	<b>5-9</b>



## 5-1 The User Interface

This section gives details on the User Interface of the Mobile I/O Box.

The 7 different screens of the User Interface can be browsed with the **Next** button.

The **Call** button will give access to functionality in the displayed screen.

### 1. Robot Call

```
Robot call:
READY
```

The second line displays the state of the Robot Call, in this example status **READY**.

Other standard Robot Call states are:

- **Initiated**  
The Mobile I/O Box did send a request to MobilePlanner.
- **Pending.**  
The state where MobilePlanner is looking for an AMR to perform the requested job.
- **UnAllocated** and then **Allocated.**  
UnAllocated is only displayed when an AMR is undocking to take the requested job.  
Allocated is displayed when an AMR is selected to start with the requested job.
- **Driving**  
The state when an AMR is driving to the set goal.  
A progress bar and the distance to the goal are displayed.
- **Cancelling** and then **Cancelled.**  
The state when a user presses the **Cancel** button before the job is finished.
- **Completed**  
The state when the AMR reached the set goal.  
Note that a distance of 0.1 m is also considered to have reached the goal.

For other Robot Call states refer to *6-2-2 Error States Mobile I/O Box* on page 6-7.

### 2. Current State

```
Current state:
Connected: True
HOST: 123.123.123.123
```

or

```
Current state:
Connected: False
HOST: 0.0.0.0
```

- **Connected** displays the connected state of the Mobile I/O Box.
- **HOST** displays the IP address of the host.

### 3. DIO Status

```
DIO Status:
IN:  0  0  0  0  0  0
OUT: 0  0  0  0  0  0
```

The status of Digital Inputs and Outputs:

- **IN** displays the status of the inputs, with **0** for not activated and **1** for activated.
- **OUT** displays the status of the outputs, with **0** for not activated and **1** for activated.

### 4. Eth0 IP Setup

```
eth0 IP Setup:
Source: Static
IP: 1.2.3.4/20
GW: 1.2.3.5
MAC: 12:12:12:12:12:12
```

or

```
eth0 IP Setup:
Source: DHCP
IP: 1.2.3.4/20
GW: 1.2.3.5
MAC: 12:12:12:12:12:12
```

- **Source** Static when configuring the Ethernet line during configuration of the Wireless communication.
- **IP** Displays the IP address of the connection.  
IP includes the netmask. E.g. In this example **/20** is the netmask.  
If the ethernet cable is not connected the IP address displays **None** .
- **GW** Displays the address of the GateWay, or **None** .
- **MAC** Displays the MAC address of the eth0 port.

### 5. *Wlan0 IP Setup*

```
wlan0 IP Setup:
Source: Static
IP: 12.3452678.90/20
GW: 1.2.3.5
SSID: TheIDName
MAC: 34:34:34:34:34:34
```

- **Source** Static when configuring the Ethernet line during configuration of the Wireless communication.
- **IP** Displays the IP address of the connection.  
IP includes the netmask. E.g. In this example **/20** is the netmask.
- **GW** Displays the address of the GateWay or **None** .
- **SSID** Displays the address of the SSID.
- **MAC** Displays the MAC address of the wlan0 port.

### 6. *Setup*

```
Setup:
Press "Call"
for setup menu
```

Refer to *5-1-1 Setup Screens* on page 5-5 for more information.

### 7. *Software Version*

```
Software:
Version:
MobileIO-1.23.456
Identifier:
MobileIO_121212
```

- **Software Version** is the software version installed on the I/O Box.  
Mention this software version when communicating with your local OMRON representative.  
This is also the ID of the SetNetGo package loaded at the host.
- **Identifier** is the unique ID of this Mobile I/O Box. This identifier is used in the Mobile Planner configuration parameters.

## 5-1-1 Setup Screens

This section gives details on the User Interface setup screens of the Mobile I/O Box.

```
Setup Menu:
-> Network setup
    Language select
    Exit setup
```

The different screens of the Setup Menu can be browsed with the **Next** button. The **Call** button will give access to functionality in the displayed screen.

### 1. Network Setup

```
Network Setup:
-> Host Address
    eth0 IP Setup
    wlan0 IP Setup
    Default Gateway
    Webserver
```

The network setup options are:

#### 1) Host Address

```
Host Address
123.123.123.123
^
```

Set the IP address of the host.

#### 2) eth0 IP Setup

```
eth0 IP Setup:
-> DHCP
    STATIC
```

Select DHCP or STATIC.

Suboptions that will appear are:

- IP Address
- IP Netmask

3) **wlan0 IP Setup**

```
wlan0 IP Setup:
-> DHCP
    STATIC
```

Select DHCP or STATIC.

Suboptions that will appear are:

- IP Address
- IP Netmask

To configure the Wi-Fi network you must use the webserver.

4) **Default Gateway**

```
Default Gateway:
123.123.123.123
^
```

Set the IP address of the gateway.

5) **Webserver**

```
Webserver:
Disabled
"Call" to toggle
```

```
Webserver:
Enabled
"Call" to toggle

Connect ethernet:
    http://12.123.123.123
```

or

Select to Enable or Disable the Webserver.

When set to Enabled an extra line will display **Connect ethernet: http://12.123.123.123**.

To configure the Wi-Fi network you must use the webserver.

Enter the supplied IP address in a browser (e.g. Edge, FireFox, Chrome) to display the webserver.

2. **Language select**

```
Language select:
-> English
    Deutsch
    Español
    Français
    Italiano
>>>>
```

Select the desired language.

3. **Exit setup**

Exit the setup menu and return to the default menu.



## 5-2 Call an AMR

Use following procedure to summon an AMR to a set goal:

- 1 Press the **Call** button.

The Mobile I/O Box will display following screens:

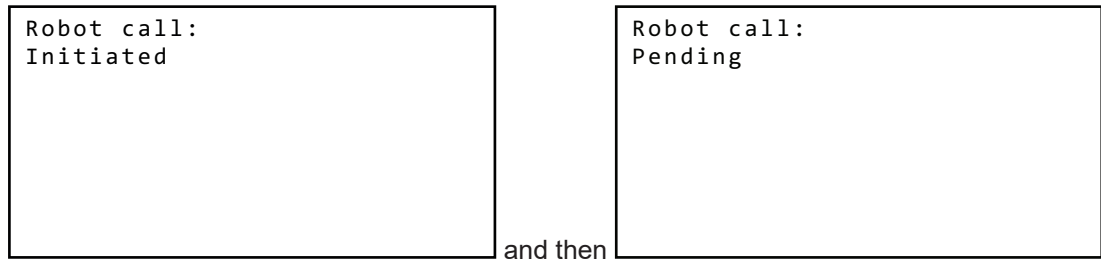

Refer to 5-1 *The User Interface* on page 5-2 for state details.

In MobilePlanner a job is created and the state is Pending until the moment the AMR starts moving. Monitor the AMR state in MobilePlanner for the status of the Call action.

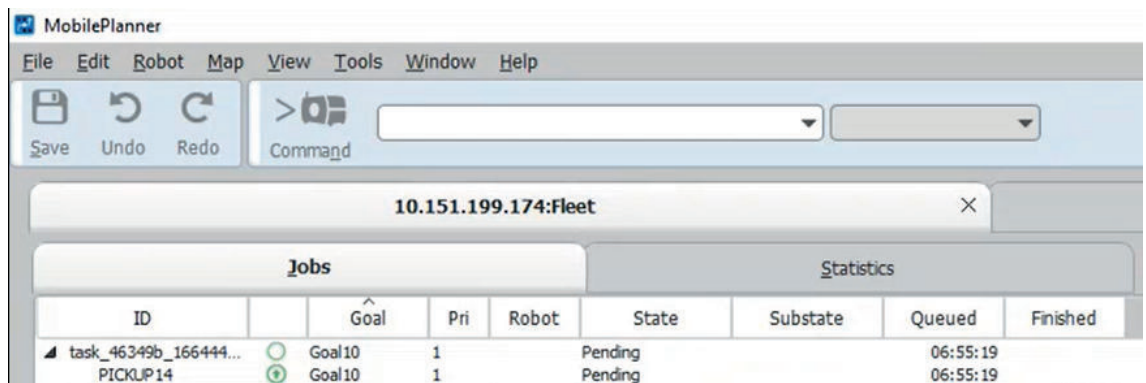

The Fleet Manager will send a Mobile Robot to the location of the Mobile I/O Box.

- 2 When the AMR starts moving, the Mobile I/O Box will display *Driving* and additional information.

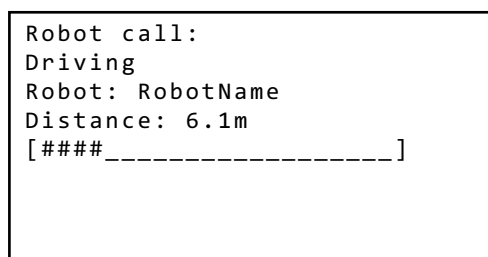

- 3** When the goal is reached the Mobile I/O Box will sound a (configurable) beep. The screen will display status *Completed* and the distance bar will be filled completely.

```
Robot call:
Completed
Robot: RobotName
Distance: 0.1m
[#####]
```



#### Additional Information

---

- When a goal is behind a door, the Fleet Manager can open the door after a configurable wait duration (parametername: WaitTime).
  - The distance will not change when the AMR is waiting. Waiting can occur when e.g. a door needs to be opened or when another AMR has a higher priority.
  - The distance might temporarily increase, depending on the route of the AMR.
  - Every goal has a configurable tolerance. For an AMR, a distance of 0.1 m to the goal is considered goal reached.
  - A goal can have a configurable orientation. If the orientation of the AMR is not according to a set orientation, then the AMR goal is not reached even if the AMR is on the correct location.
- 

The AMR is called and has arrived at the set goal.

## 5-3 Cancel an AMR Summon Request

---

This procedure describes how to cancel a summon request for an AMR.

- 1** Press the **Cancel** button.  
Refer to *1-2 Product Overview* on page 1-3 for the Cancel button location.  
The Fleet Manager will cancel the summon request for an AMR that was scheduled to visit the goal location of the Mobile I/O Box.  
The User Interface displays *Robot call: Cancelling*
- 2** Wait until the User Interface displays *Robot call: Cancelled*.

The summon request for an AMR is canceled.





# Maintenance

This section provides information on preventive and corrective maintenance actions.

---

<b>6-1</b>	<b>Preventive Maintenance .....</b>	<b>6-2</b>
6-1-1	Preventive Maintenance Schedule .....	6-2
6-1-2	Clean the Mobile I/O Box .....	6-2
6-1-3	Replace the Battery .....	6-3
<b>6-2</b>	<b>Corrective Maintenance .....</b>	<b>6-6</b>
6-2-1	Error Situations .....	6-6
6-2-2	Error States Mobile I/O Box .....	6-7
6-2-3	Error Messages MobilePlanner .....	6-9

# 6-1 Preventive Maintenance

Preventive Maintenance covers all actions that prevent downtime.

## 6-1-1 Preventive Maintenance Schedule

Prevent unscheduled downtime with the following preventive maintenance schedule.

Weekly	Reference
Clean the Mobile I/O Box	Refer to 6-1-2 <i>Clean the Mobile I/O Box</i> on page 6-2 for more information.
Periodically but at least every 6 months	Reference
Check the ambient environment: <ul style="list-style-type: none"> <li>• Temperature and humidity within specifications</li> <li>• Noise sources not close to the Mobile I/O Box</li> </ul>	Refer to 2-2 <i>Environmental Specifications</i> on page 2-3 for more information.
Check if the Mobile I/O Box is mounted securely	Refer to 3-3 <i>Mount</i> on page 3-4 for more information.
Check wiring and connections: <ul style="list-style-type: none"> <li>• Cable connectors fully inserted and locked</li> <li>• No damaged wiring or connectors</li> </ul>	Refer to 3-4 <i>Connect</i> on page 3-5 for more information.
Every 5 years	Reference
Replace the battery	Refer to 6-1-3 <i>Replace the Battery</i> on page 6-3 for more information.

## 6-1-2 Clean the Mobile I/O Box

Clean the surface of the Mobile I/O Box when necessary to keep it in the best operating condition.

- Ensure the I/O Box is OFF before cleaning to prevent activating one of the keys.
- Wipe the I/O Box with a dry, soft cloth. If the screen is very dirty and you try to clean it with a dry cloth, you may scratch the surface. Use a damp cloth first to remove the dirt.
- When a spot cannot be removed with a dry cloth, dampen the cloth with a neutral cleanser, wring out the cloth and wipe the touchscreen surface.
- Remove all residue from gum, vinyl or tape when cleaning.



### Additional Information

Allowed cleaning materials for the screen surface:

- Isopropyl alcohol
- Detergents between pH 5 and pH 8
- Rinse with demineralized water after cleaning
- Demineralized water

## 6-1-3 Replace the Battery

Use the following procedure to replace the Real Time Clock battery.



### Precautions for Safe Use

- Batteries may leak, rupture, heat, or ignite. Never short-circuit, charge, disassemble, heat, or incinerate a battery or subject it to strong shock.
- Dispose of any battery that has been dropped or otherwise subjected to excessive shock. Batteries that have been subjected to shock may leak if they are used.

To replace the battery:

- 1** Disassemble the Mobile I/O Box to get access to the battery.  
Refer to *Disassemble the Mobile I/O Box* on page 6-4 for more information.
- 2** Push out **(A)** the battery with a non-conductive flat tool to remove it. Replace the battery while observing orientation for correct polarity indicated on the battery compartment (+ facing up).  
Refer to *Battery CR2032* on page 6-4 for battery details.

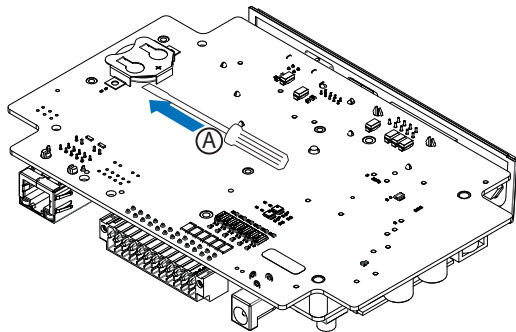

- 3** Reassemble the Mobile I/O Box to complete this procedure.  
Assemble the Mobile I/O Box in the reverse order.  
Refer to *Disassemble the Mobile I/O Box* on page 6-4 for more information.

The battery is replaced.

## Battery CR2032

Following battery is used for your Mobile I/O Box.

Model	Appearance	Specifications
CR2032		Service life: 5 years at 25°C



### Additional Information

Refer to the label on the battery package for the Best If Used By date.

## Disassemble the Mobile I/O Box

Use the following procedure to disassemble, and optionally reassemble, the Mobile I/O Box.



### Precautions for Safe Use

- Ensure power is disconnected.
- This procedure should be performed by personnel in charge of installing and maintaining FA systems.

To open the Mobile I/O Box:

- 1** Remove the power connector and then remove all other connectors from the I/O Box.
- 2** When mounted then unmount the I/O Box.  
Place the I/O Box with the frontside on a flat soft surface.
- 3** Remove the 4 rubber feet from the I/O Box when these are mounted.  
Inside the 4 holes at the backside Phillips screws are now accessible.  
Remove the 4 Phillips screws that are mounted with a torque of 0.3 N m.

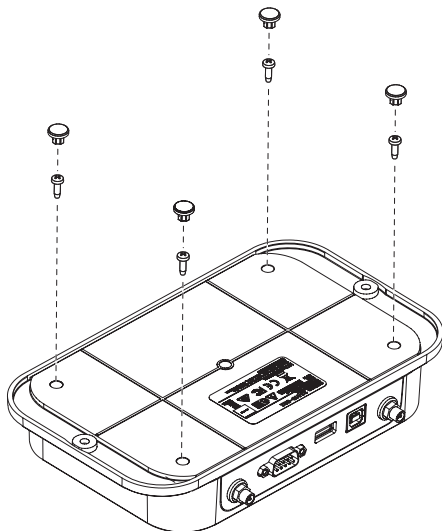

- 4** Place the I/O Box with the backside on a flat soft surface.



- 5** Lift and then remove the top cover.

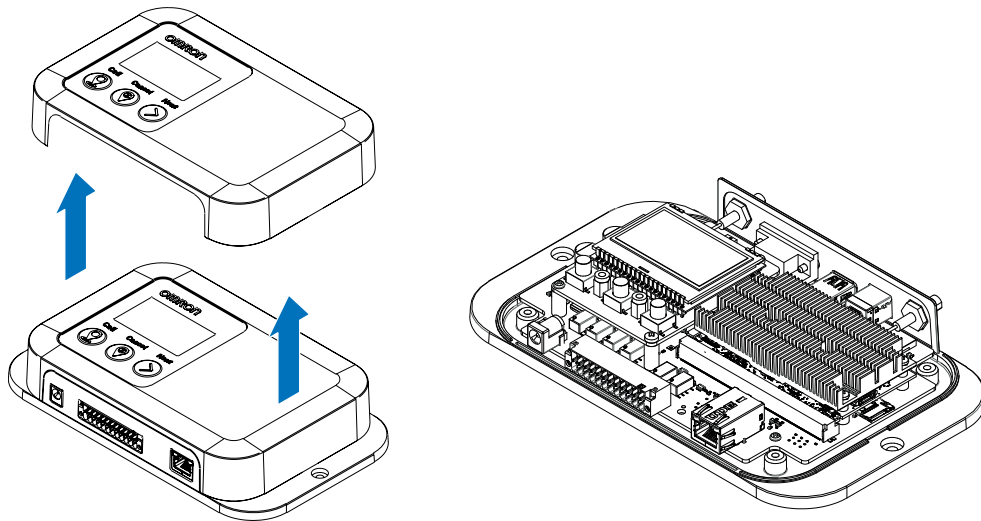

The electrical assembly is now visible, mounted to the bottom plate.

- 6** Remove the 4 Phillips screws **(A)** that mount the electrical assembly to the bottom plate. The 4 screws are mounted with a torque of 0.3 N m.

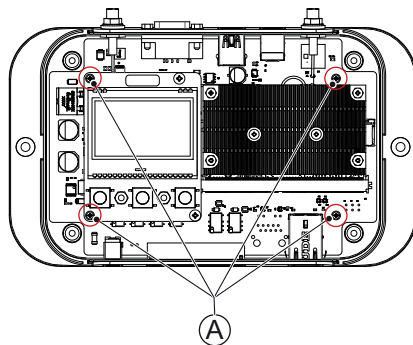

- 7** Lift the complete electrical assembly **(B)** and put it upside down on a non-conductive surface. The battery **(A)** is now visible to be removed or replaced.

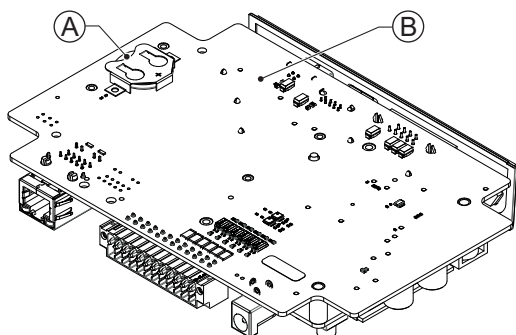

- 8** Assemble the Mobile I/O Box in reverse order.

The Mobile I/O Box is disassembled for maintenance or recycling purposes.

## 6-2 Corrective Maintenance

Corrective maintenance covers all actions to correct problems that cause downtime.

WARNING

Do not attempt to repair or modify the product in any way. Doing so may result in malfunction or fire.



Contact your local OMRON representative if the corrective maintenance actions did not solve the problem.

### 6-2-1 Error Situations

Error situations are situations that obstruct the intended use of the Mobile I/O Box.

Possible error situations:

Situation	Explanation	Corrective Action
Error states on the Mobile I/O Box	A state on the Mobile I/O Box can indicate a state where action is required.	Refer to <i>6-2-2 Error States Mobile I/O Box</i> on page 6-7 for more information.
Error message in MobilePlanner	An error in MobilePlanner can indicate the Mobile I/O Box configuration is not correct.	Refer to <i>6-2-3 Error Messages MobilePlanner</i> on page 6-9 for more information.
Configuration is not possible	In SetNetGo the MobileIO package is not available because the MobileIO package is not installed.	Install the MobileIO package. Refer to <i>SetNetGo - MobileIO</i> on page 4-5 for more information.
Unexpected behavior of the Mobile I/O Box	The Mobile I/O Box is not functional.	Refer to <i>Mobile I/O Box - Not Functional</i> on page 6-6 for more information.

### Mobile I/O Box - Not Functional

Use this procedure when Mobile I/O Box actions appear to have no effect.

- 1** Check if the Mobile I/O Box is powered ON.  
Refer to *3-4 Connect* on page 3-5 for more information.
- 2** Verify the functionality.  
Refer to *4-5 Verify the Functionality* on page 4-15 for more information.

The Mobile I/O Box is functional.

## 6-2-2 Error States Mobile I/O Box

The following table lists Mobile I/O Box error states.



### Additional Information

Error states displayed on the Mobile I/O Box can be the result of incorrect settings or the result of settings in related software.

Screen	Error State	Explanation	Corrective Action
Robot Call	<b>NOT CONNECTED</b>	IP Address not entered or not entered correctly.	Enter the IP address of the host.
		Wire breakage or Connector problem or other cause for disconnection.	Ensure there is a connection between the MIOB and the host.
		The MobileIO package is not in the state Running.	Restart the MobileIO package.
	<b>ERROR</b>	Can be visible just before entering the state 'Ready'.	No action required, this state will change automatically to state 'Ready'.
		The 'Call button' is pressed but there is no goal configured.	Configure a goal.
<b>CANCELLED</b>	Can be visible just before entering the state 'Ready'.	No action required, this state will change automatically to state 'Ready'.	
eth0 IP Setup	<b>DISABLED</b>	The wired ethernet interface is turned off in the Setup screen.	Enable Eth0 in the Setup screen.
	<b>Invalid - static IP NOT set</b>	The entered IP address is not accepted.	Press "Call" to resolve this error. Re-enter the IP address.
	<b>IP not set - Duplicate local IP</b>		
	<b>Bad Default Gateway IP. Try again</b>		
wlan0 IP Setup	<b>DISABLED</b>	The wireless ethernet interface is turned off in the Setup screen.	Enable Wlan0 in the Setup screen.
	<b>Invalid - static IP NOT set</b>	The entered IP address is not accepted.	Press "Call" to resolve this error. Re-enter the IP address.
	<b>IP not set - Duplicate local IP</b>		
	<b>Bad Default Gateway IP. Try again</b>		
_ *1	<b>PROCESS TERMINATED</b>	An unknown error occurred.	No action required. The MIOB will automatically reboot and return to the Robot Call screen.

Screen	Error State	Explanation	Corrective Action
Firmware Update *2	<b>Stage: DOWNLOAD</b> <b>Stage: UNPACK</b> <b>Stage: FLASH</b> <b>Stage: IDLE</b> <b>Stage: REBOOT</b> <b>Process terminated</b> <b>Omron MobileIO</b>	These states will be visible only when flashing the firmware.	No action required. The MIOB will automatically reboot and return to the Robot Call screen.
ERROR:	<b>Firmware Update Failed.</b> <b>Press "Call" to confirm.</b>	This error message will be visible when there was an error while flashing the firmware.	Press "Call" to resolve this error. Ensure the firmware image is correct and then retry the firmware update.

\*1. Not a selectable screen but a message that might appear.

\*2. Not a selectable screen, it will appear when performing a Firmware upgrade.  
 The sequence of stages and states will change automatically.

## 6-2-3 Error Messages MobilePlanner

The following table lists error messages in MobilePlanner that are related to the Mobile I/O Box.

Error Message	Details
Device ID button pressed with no goal assigned.	Refer to Message "Device ID button pressed with no goal assigned" on page 6-9 for more information.

### Message "Device ID button pressed with no goal assigned"

The message **Device ID button pressed with no goal assigned** appears in MobilePlanner if the **Call** button is pressed but there is no goal assigned. MobilePlanner does not know where to send the AMR.

To assign a goal to a Mobile I/O Box:

- 1** Locate the Mobile I/O Box.  
 In MobilePlanner the ID of the message represents the MAC address of the applicable Mobile I/O Box.  
 Confirm the MAC address in the message is identical to the MAC address of the Mobile I/O Box that is visible in the **Eth0 IP Info** screen.
- 2** Assign a goal to the located Mobile I/O Box.  
 Refer to *4-4-3 Configure the Call Function* on page 4-11 for more information.
- 3** Confirm the solution.
  - Select the **Call** button on the located Mobile I/O Box.
  - Check the message does not reappear in MobilePlanner.
  - Ensure the AMR comes to the set goal.

The goal is assigned to the correct Mobile I/O Box.





# Index



# Index

---

<b>A</b>		
Altitude.....	2-3	
<b>B</b>		
Battery .....	6-4	
<b>C</b>		
Call Function.....	1-6	
Call		
Call button .....	5-7	
Cancel		
Cancel button .....	5-9	
Communication.....	1-5	
Configure.....	4-2	
Mobile I/O Box.....	4-6	
MobilePlanner.....	4-8	
Connect .....	3-5	
Connectors .....	2-5	
Corrective maintenance .....	6-6	
<b>E</b>		
Environment (operating).....	1-2	
Error Messages.....	6-9	
Error States.....	6-7	
Ethernet connectors		
LED indicators .....	2-11	
Link/Act indicator .....	2-11	
Specifications .....	2-10	
Speed indicator .....	2-11	
External Digital I/O.....	1-6	
<b>F</b>		
Functions.....	1-6	
<b>H</b>		
Humidity.....	2-3	
<b>I</b>		
I/O connector		
Specifications .....	2-5	
<b>O</b>		
Operating Temperature.....	2-3	
<b>P</b>		
Protection Class.....	2-3	
Pollution Degree.....	2-3	
Power supply .....	3-6	
Preventive maintenance .....	6-2	
<b>R</b>		
RP-SMA Antenna		
Specifications .....	2-13	
<b>S</b>		
Setup .....	5-5	
Specifications		
Physical.....	2-2	
Storage Temperature.....	2-3	
<b>U</b>		
Unpack .....	3-3	
USB connectors		
Specifications .....	2-9	
User Interface .....	5-2	





## **OMRON Corporation Industrial Automation Company**

**Kyoto, JAPAN**

**Contact : [www.ia.omron.com](http://www.ia.omron.com)**

### ***Regional Headquarters***

#### **OMRON EUROPE B.V.**

Wegalaan 67-69, 2132 JD Hoofddorp  
The Netherlands  
Tel: (31) 2356-81-300 Fax: (31) 2356-81-388

#### **OMRON ASIA PACIFIC PTE. LTD.**

438B Alexandra Road, #08-01/02 Alexandra  
Technopark, Singapore 119968  
Tel: (65) 6835-3011 Fax: (65) 6835-2711

#### **OMRON ELECTRONICS LLC**

2895 Greenspoint Parkway, Suite 200  
Hoffman Estates, IL 60169 U.S.A.  
Tel: (1) 847-843-7900 Fax: (1) 847-843-7787

#### **OMRON (CHINA) CO., LTD.**

Room 2211, Bank of China Tower,  
200 Yin Cheng Zhong Road,  
PuDong New Area, Shanghai, 200120, China  
Tel: (86) 21-5037-2222 Fax: (86) 21-5037-2200

**Authorized Distributor:**

©OMRON Corporation 2023 All Rights Reserved.  
In the interest of product improvement,  
specifications are subject to change without notice.

**Cat. No. I677-E-01** 0223

24334-000 A