

# Short-Term Revamping Technology for Large Blast Furnace<sup>†</sup>

FUJITA Masao<sup>\*1</sup> TOKUDA Keiichiro<sup>\*2</sup> KOJIMA Hirotaka<sup>\*3</sup>

## Abstract:

To revamp a blast furnace (BF) is required about every 15 years, and revamp duration by a conventional method is around 130 days. JFE Steel has developed a new revamping method, so called "Large Block Ring Construction Method." By employing the method, the revamp duration was remarkably reduced to a half of a conventional one. A furnace body (10 000 t) was segmented into blocks of 10 t to 20 t weight during dismantling and installation in conventional method. Blocks by the Large Block Ring Constitution Method weigh over 2 000 t a piece. Consequently, the revamp duration of No. 6 BF at East Japan Works (Chiba) in 1998 was only 62 days, which was the world shortest record of revamp duration. The method was also successfully adopted to No. 5 BF at West Japan works (Fukuyama) in 2005, and established a new world record of 58 days.

## 1. Introduction

In recent years, the blast furnace (BF) in integrated steel works not only produces hot metal (molten pig iron) for steelmaking, but also plays the role of an energy base, supplying by-product gas to the steel works as a whole. Once a blast furnace is blown in, it supplies hot metal and by-product gas continuously until the furnace body reaches the end of its life. When a furnace approaches the end of its useful life, operation is stopped, repair, relining, and modernization work (revamping) are performed, and the furnace is blown in for resuming operation. Because the supply of hot metal and by-product gas is stopped for the duration of the revamping work, shortening of the revamping period

and extension of the life of the blast furnace, which determines the revamping cycle, are important for the steel works. With recent large-scale blast furnaces, the revamping period was around 130 days and blast furnace life was approximately 15 years. However, JFE Steel set new world's records for both short-term revamping and long furnace life, completing a revamp of the West Japan Works Fukuyama District No. 5 BF (Fukuyama No. 5 BF) in only 58 days (2005) and achieving life of 24 years, 5 months with the West Japan Works Kurashiki District No. 2 BF (Kurashiki No. 2 BF) (2003). As a short-term revamping technology, JFE Steel led the world in developing the Large Block Ring Method<sup>1-3)</sup>, which reduced the conventional revamping period by half when applied in revamping the East Japan Works Chiba District No. 6 BF (Chiba No. 6 BF) in 1998. The 58-days revamp at Fukuyama No. 5 BF was also carried out using this method. This paper presents an outline of ultra-short-term revamping by the Large Block Ring Method and describes the main newly-developed technologies which make this method possible.

## 2. Outline of Development

A blast furnace is a large-scale structure standing 110 m above the ground and having a total mass of approximately 10 000 t. Blast furnace revamping refers to construction work in which the body of the furnace is dismantled and a new furnace body is then assembled in the blast furnace structure. The conventional revamping method was a labor-intensive technique in which the mantle was divided into blocks weighing several tens of tons for dismantling/assembly. In contrast, the

<sup>†</sup> Originally published in *JFE GIHO* No. 11 (Apr. 2006), p. 1-8



<sup>\*1</sup> Staff, Plant Engineering Technology Sec.,  
Plant Engineering Dept.,  
West Japan Works (Fukuyama),  
JFE Steel



<sup>\*2</sup> General Manager,  
Plant Engineering Dept.,  
West Japan Works (Kurashiki),  
JFE Steel



<sup>\*3</sup> Staff Assistant General Manager,  
Blast Furnace Relining Project Team,  
JFE Mechanical

Table 1 Comparison of conventional revamp and Large Block Ring Construction Method

Revamp method	Conventional revamp	Large Block Ring Construction Method
Construction method	Carry 10–20 t shell units into site and assemble at site	Transport pre-assembled ring-blocks of 2 000 t into site
Unit number and weight	500–1 000 units 1 unit: 10–20 t	3–4 units 1 unit: 2 000 t
Revamp duration	130 days	58 days

Table 2 Revamp duration by Large Block Ring Method

	Chiba No. 6 BF	Kurashiki No. 4 BF	Kurashiki No. 2 BF	Fukuyama No. 5 BF
Revamp duration (day)	62	70	75	58
Revamp time (year)	1998	2001	2003	2005
Inner volume (m <sup>3</sup> )	5 153	5 005	4 100	5 500

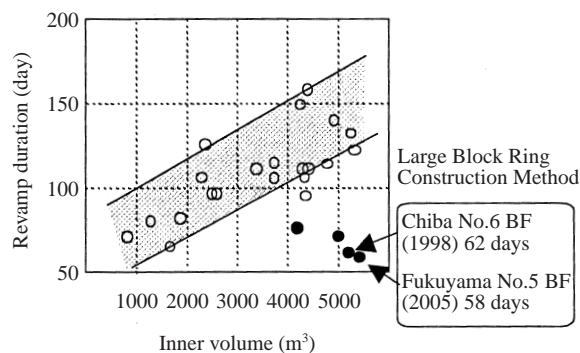

Fig. 1 Relation between inner volume and duration of revamps

Large Block Ring Method is a revolutionary technology in which a new mantle is fabricated in advance in 3–4 large blocks weighing approximately 2 000 t, and work during the actual revamp is limited to transportation and joining of these blocks. **Table 1** shows a comparison of the conventional method and the new Large Block Ring Method.

In blast furnace revamping projects since 1998, JFE Steel has carried out short-term revamping by the Large Block Ring Method, as shown in **Table 2**. The blast furnace revamping period is proportional to the inner volume of the blast furnace. **Figure 1** shows a comparison of the revamping period for other Japanese blast furnaces. Although Fukuyama No. 5 BF is JFE Steel's largest blast furnace, revamping was completed in 58 days, renewing the world's record for shortest revamping time previously held by JFE Steel's Chiba No. 6 BF.

### 3. Problems with Conventional Method

#### 3.1 Outline of Conventional Method

The conventional blast furnace revamping method was a labor-intensive construction method which required mobilization of personnel totaling approximately 1 500 man/day. Moreover, it was difficult to achieve any large reduction in the work period because work space was limited and dismantling/assembly work were performed successively. The following presents an outline of the conventional revamping work (**Fig. 2**).

#### (1) Dismantling of Residual Materials in Furnace Bottom

After blast furnace operation is stopped and the furnace has been cooled, residual materials (slag and coke) in the furnace bottom are raked out with shovels, and the residual iron remaining in the hearth is broken up into smaller pieces weighing several tens of tons by dynamiting and removed. In dismantling of the residual iron, the blasting/removal process is rate-governing, and dismantling requires approximately 30 days.

#### (2) Dismantling of Old Mantle

The old mantle is dismantled by cutting into smaller blocks. This process requires approximately 20 days due to the large number of blocks, together with the constricted work area and restrictions on the routes for removing the blocks.

#### (3) Assembly of New Mantle and Cooling Equipment

Due to restrictions on the lifting capacity of cranes, etc., the new mantle is assembled by horizontal movement of blocks weighing several tens of tons in the narrow confines of the furnace interior. Next, the cooling equipment, called stove (comprising approximately 500 pieces), is brought in by crane and

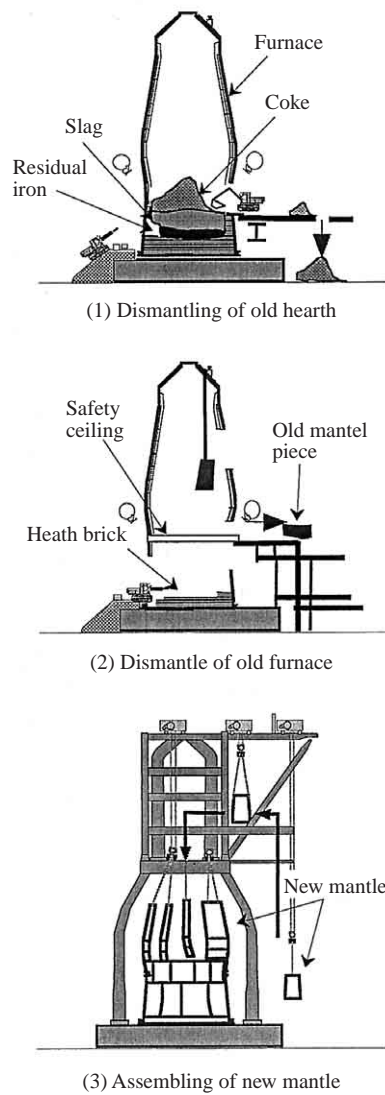

Fig.2 Outline of conventional method

mounted on the furnace body. Due to the large number of blocks which must be moved into place, this work requires approximately 40 days.

- (4) Furnace Relining Work and Preparation for Blow-in Requires approximately 40 days.

Thus, as the total of the above (1) through (4), the conventional revamping method requires approximately 130 days.

### 3.2 Problems with Conventional Method

The problems with the conventional method are described in the following.

- (1) Limits on Shortening of Revamping Period

Due to limitations on the transportation and lifting capacities of the equipment used in both the furnace dismantling work and assembly work, the weight of components delivered to the site was limited to several tens of tons, and consequently, the number of blocks was between 500 and 1 000. Due to the constricted work space and restrictions on

removal/delivery routes, the volume of work per day was limited to at most 10–20 blocks. As a result, approximately 130 days was the limit for the revamping period with the conventional method, and it was difficult to achieve any large reduction in this period.

- (2) Poor Work Environment

Because the work inside the furnace consisted of removal/delivery of heavy components in a constricted space, accidents in which personnel might fall or be crushed were an important safety concern. Furthermore, because the residual iron was broken up by dynamiting, removal of the resulting irregular-shaped pieces required heavy labor in a dust-filled environment.

- (3) Declining Number of Skilled Personnel

The work of removing/delivering heavy components inside the blast furnace is skilled work involving precise placement of heavy components in a limited space in high places, and a large number of skilled personnel are required in blast furnace revamping. However, in recent years, the frequency of blast furnace revamping has decreased as a result of the trends toward large-scale blast furnaces and extended furnace life, making it difficult to secure skilled personnel.

To solve these problems, JFE Steel conceived a method of fabricating large block rings in advance, in which the new furnace body is divided into only 3–4 blocks, and transporting these components to the construction site in block units. In other words, it was thought that a large reduction could be achieved in the revamping period for the first time, and all of the above-mentioned problems could be solved, by realizing the Large Block Ring Method.

## 4. Outline of Large Block Ring Method

The Large Block Ring Method is a revolutionary blast furnace revamping method in which dismantling/assembly are performed in large block units, with the furnace mantle divided into 3–4 blocks. An outline is presented in the following.

### 4.1 Dismantling Process

An outline of the dismantling process is shown in Fig. 3.

- (1) Unitary Dismantling of Operating Floor

In order to secure a route for removal/delivery of the furnace body in large blocks, the operating floor is removed in a single unit by transporting trucks.

- (2) Dismantling of Furnace Bottom

The residual materials (slag, coke) in the furnace bottom are dismantled and the residual iron is removed in large blocks. The furnace body is then

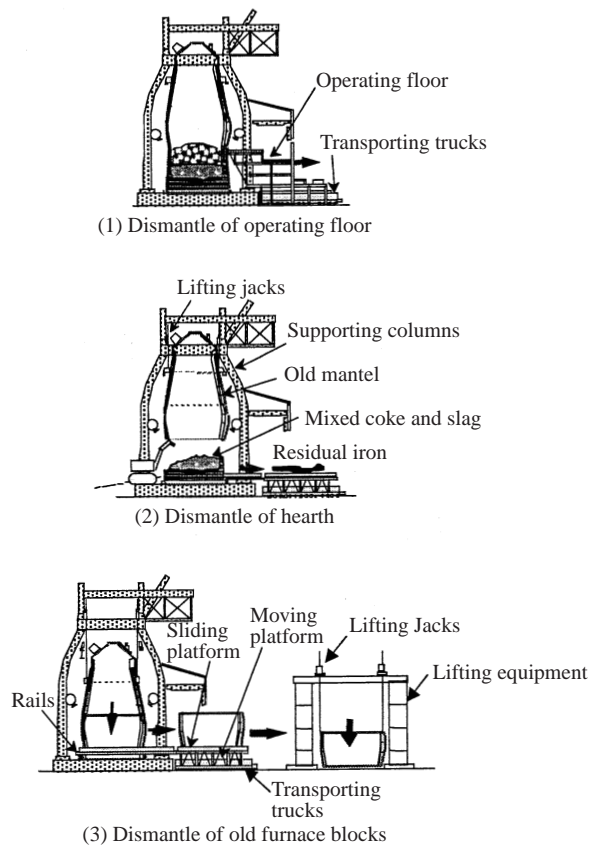

Fig. 3 Outline of dismantling operation in Large Block Ring Method

lowered from the top of the structure of the blast furnace by lifting jacks.

### (3) Removal of Old Furnace Blocks

After the hearth is dismantled, rails are laid in the furnace and the furnace blocks, divided into three pieces, are placed on a sliding platform and moved on a moving platform at the same level as the blast furnace foundation (height of 5–7 m above the ground). The furnace blocks are moved by transporting trucks as far as the off-line lifting equipment, and are then lowered to the ground by the lift jacks of the lifting equipment.

By repeating the above steps (1) through (3), it was possible to dismantle the old furnace body in large blocks.

## 4.2 Assembly Process

As an example, Fig. 4 show an outline of the assembly process with the Large Block Ring Method when the new mantle is divided into 4 blocks.

### (1) Advance Construction of New Mantle

The new mantle is fabricated in advance in 4 blocks. With each block, large block rings are prepared by constructing the furnace shell and cooling equipment (staves) and the refractories between these parts in advance. The mass of each block is 1 000–2 000 t (Photo 1).

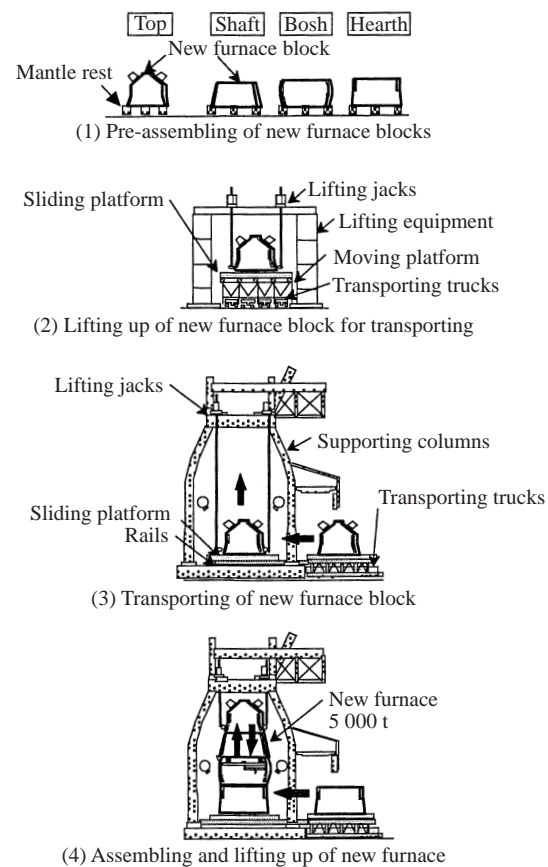

Fig. 4 Outline of assembling operation in Large Block Ring Method

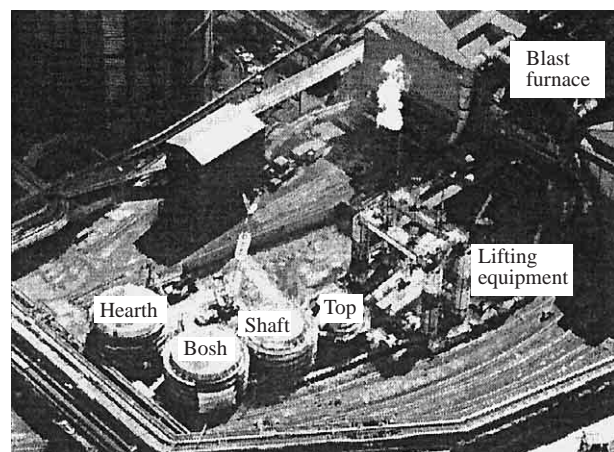

Photo 1 Pre-assembly of new furnace blocks

### (2) Preparation for Transportation of New Mantle

The new mantle is lifted by the lifting equipment and loaded on the moving platform.

### (3) Delivery of New Mantle

The new mantle is transported as far as the furnace foundation by transporting trucks, and is then moved into the structure of the blast furnace by the sliding platform. Each furnace block is lifted up from the sliding platform by the lift jacks at the top of the furnace, and the sliding platform is pulled out. Succeeding furnace blocks are moved into the furnace in



order by the same process. The succeeding blocks are joined and welded to the preceding blocks, and this assembly is then lifted up.

#### (4) Overall Lifting/Installation of New Mantle

After the final furnace block has been transported into the furnace and joined/welded to the upper blocks, the new mantle with a total mass of 5 000 t is raised and the sliding platform is removed to outside of the furnace. The new mantle is then installed on the foundation, completing the assembly of the new mantle.

This is followed by furnace interior relining work and preparation for blow-in. By dismantling the furnace body and assembling the new mantle in large blocks, a large reduction in the revamping term is possible.

### 5. Technologies Developed for Achievement of Large Block Ring Method

Ultra-short-term revamping by the Large Block Ring Method was made possible by technical development of the following seven items.

#### 5.1 Transportation/Lifting Technique for Composite Structure Including Refractories

The furnace blocks are composite structures consisting of the furnace shell, staves, and refractories (**Fig. 5**). The most important challenge was to prevent cracks in the refractories during transportation and lifting, as the refractories have the greatest influence on furnace life. However, because no knowledge was available on cracking in refractories in a composite structure, a full-scale model was prepared and the conditions under which cracking occurs in refractories were analyzed experimentally. This experiment was conducted with 4-point support by the lifting equipment (**Photo 2**), as deformation of the furnace blocks during transportation and lifting is greatest under this condition. The following were confirmed based on the results of this experiment.

- (1) Reinforcing structure and strength of reinforcements necessary to prevent deformation of furnace blocks
- (2) Deformation limit of furnace blocks without causing cracks in refractories

In addition, application of the experimental data made it possible to improve the accuracy of structural analysis of the composite structure and design reinforcing structures for furnace blocks with different shapes. Thus, this technical development made it possible to transport and lift furnace blocks with a composite structure without causing cracks in the refractories.

#### 5.2 Development of High Efficiency Structural Analysis System

With the Large Block Ring Method, in the stage

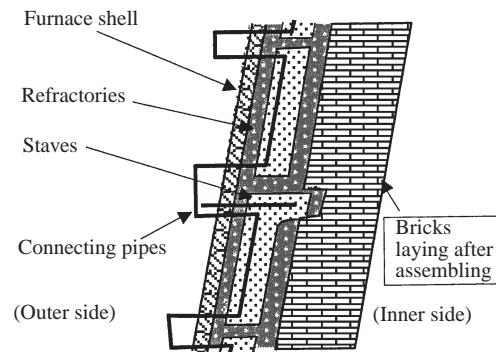

Fig. 5 The section of furnace block

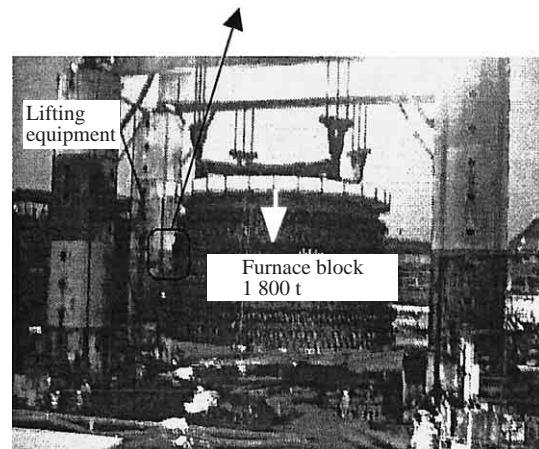

Photo 2 4 points supporting in lifting equipment

when joining of the furnace blocks has been completed, it is necessary to lift the new mantle, which has a total mass of 5 000 t, using the structure of the blast furnace. However the bearing capacity of the beams in the blast furnace structure is approximately 1 000 t. Therefore, in order to lift the 5 000 t mantle in a single unit, it was necessary to install a reinforcing structure which would greatly increase the strength of the beams. In comparison with general structures, a blast furnace has a complex 3-dimensional structure, load conditions are on the order of several 1 000 t, and the members used in the structure exceed 3 m, which means the volume of data for analysis is large. With ordinary structural analysis systems, it was difficult to analyze blast furnace structural models for as many as several tens of cases. To solve this problem, JFE Steel developed a specialized high efficiency structural analysis system for blast furnaces called JBSD (JFE Steel Blast furnace Structure Design system)<sup>4</sup>. The features of the system are as follows.

- (1) Automatic calculation of all stresses in all members/total cross-section specialized for components used in the structure of the blast furnace.
- (2) Automatic search for the maximum value of stress by group from several million stress values calculated by the system.
- (3) Automatic generation of approximately 30 load conditions, including seismic loads specific to blast

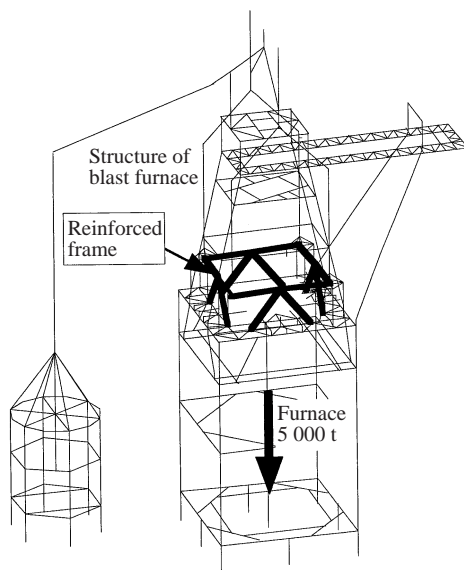

Fig. 6 Model for framed structure analysis of blast furnace

furnaces, from input of basic load conditions.

An example of analysis of a reinforcing structure using JBSD is shown in Fig. 6. This analysis system made it possible to analyze approximately 100 models of the structure of the blast furnace in a short time, and thereby realized the design for a reinforcing structure for lifting the 5 000 t furnace mantle.

### 5.3 Single-Bevel Groove Welding Technique

With the Large Block Ring Method, the only field welding required is welding of the upper/lower furnace block rings. As a result, the amount of field welding is less than 1/10 that with the conventional method, enabling a reduction in revamping time. However, it was necessary to solve the following problems in field welding of the furnace blocks.

- (1) Because refractories and staves are installed on the inner side of the furnace blocks, welding is limited to single-bevel groove welding from the outer side, but the backing plate which is necessary in single-bevel groove welding of plates cannot be attached in the field (Fig. 7).
- (2) Root face error in the steel shell at field-welded joints (linear misalignment in the fitting accuracy of the upper and lower sections of the shell) cannot be forcibly repaired, as this will cause cracks in the refractories.

Therefore, the optimum dimensions/shape and welding conditions for the groove and backing plate were obtained considering limitations due to shell joint accuracy (maximum linear misalignment: 6 mm), assuming that the backing plate will be attached in advance. As a result, it was concluded that defect-free welding is possible.

The development of this technique made it pos-

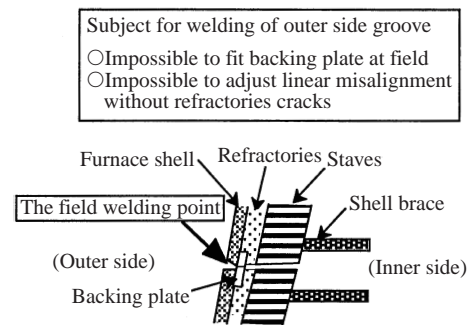

Fig. 7 The welding of one side groove

sible to weld the furnace blocks in the Large Block Ring Method.

### 5.4 Technique for Realizing High Accuracy in Steel Shell Joining Work

As mentioned above, with the Large Block Ring Method, it is impossible to correct shell fitting error in the field due to the possibility of refractory damage. Accordingly, maintaining the accuracy of joints until immediately prior to field welding was an essential condition. In order to realize high accuracy in joints, the joint parts of the upper and lower shell sections were finished in a ring as a single unit in the shop, enabling installation with fitting accuracy of 3 mm or less at the joints. The shell reinforcements described in paragraph 5.1 were installed above and below the joint in this condition. Deformation of the shell during the process from transportation/advance assembly to joining at the site was prevented by restraining the shell ring in this manner, realizing high accuracy in joints. For joint positioning, centering jigs were installed in the shop, making it possible to reproduced the positioning accuracy in the shop during joining at the site (Fig. 8).

With this high accuracy technique for joining the steel shell blocks, fitting linear misalignment dur-

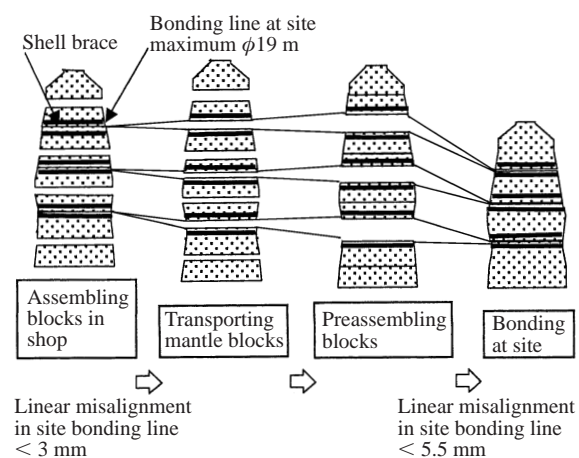

Fig. 8 Technology of precise bonding by welding between large block rings

ing joining at the site was reduced to 5.5 mm or less, enabling speedy positioning and sound welding of joints.

### 5.5 Technique for Removal of Residual Iron Block

The dismantling process was greatly shortened by removing the residual iron block (550 t) in the hearth in a single mass rather than breaking it up into smaller pieces by dynamiting. The method is explained below.

- (1) The residual iron was jacked up from the hearth bricks. Trucks capable of supporting this heavy load were inserted under the block, and the block was pulled out on the moving platform.
- (2) The residual iron block was moved to the lifting equipment and hoisted from the moving platform (**Photo 3**).
- (3) The residual iron was placed on transporting trucks by the lifting equipment and transported to the residual iron yard.

In order to remove the block of residual iron, it is essential to lift the heavy residual iron block with the lifting equipment. However, because the residual iron has an irregular shape and welding is not possible, a method of hoisting the block using bands made from steel plates was devised. The optimum shape of the hoisting bands enabling uniform distribution of the load on the entire band width surface was obtained by performing a full-scale, full-load experiment in advance using a forging press. The development of this technique resulted in a substantial shortening of the residual iron dismantling process.

### 5.6 Transportation/Lifting Technique for Heavy Objects

The furnace blocks are lifted with the lifting equipment, placed on the moving platform, and transported to the furnace foundation. The blocks are then transferred

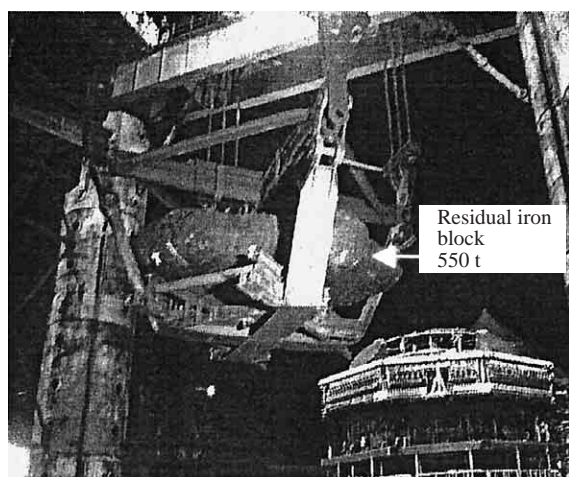
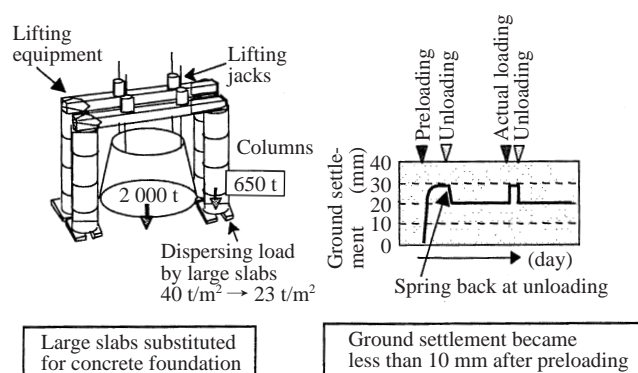

Photo 3 Hanging up large residual iron block



Large slabs substituted for concrete foundation

Ground settlement became less than 10 mm after preloading

Fig. 9 Technology of foundationless lifting equipment and settlement trend at loading

from the moving platform to the furnace foundation by the sliding platform. Therefore, countermeasures to prevent ground subsidence due to the transportation and lifting of heavy objects weighing 2 000 t were necessary. While the 2 000 t furnace blocks are lifted by the lifting equipment, a foundation load of 650 t acts on each of the four supporting columns. However, focusing on the fact that the furnace body would actually be lifted during the revamping work for a short time of within several hours, JFE Steel undertook the challenge of a foundation-less method in order to reduce the revamping period. In the foundation part, a structure for distribution of the load was created by laying a large slab instead of the conventional concrete foundation. The schedule of the revamping work was also carefully studied, and the hoisting equipment was improved in order to minimize the time when the furnace blocks would be suspended by the lifting equipment. Changes in the amount of ground settlement within the time when the furnace blocks would be suspended were investigated. Actual loads were applied to the ground under each of the four supporting columns, and the results confirmed that ground settlement is stable, at a maximum of 30 mm, and changes in settlement would not present a problem if within the time when the furnace body would be suspended. As springback was also 10 mm at maximum, a decision was made to correct for these changes using the lift jacks of the lifting equipment (**Fig. 9**). Ground settlement during temporary holding of the furnace blocks after transportation to a position in front of the furnace foundation was also confirmed in advance by laying a large slab which imposed the same load as the furnace blocks. This technique made it possible to transport and lift the 2 000 t furnace blocks without constructing a permanent foundation.

### 5.7 Space-Saving Techniques

In the revamping project at Chiba No. 6 BF, the Large Block Ring Method was realized using a construction space of 15 000 m<sup>2</sup>. However, the construction



space which could be secured for the Kurashiki No. 4 BF revamping project (2001) was limited to 6 500 m<sup>2</sup>, even using a rail line near the blast furnace and a dry pit for slag treatment. In order to expand the adoption of the Large Block Ring Method to general blast furnaces, space-saving techniques are necessary. Therefore, the following techniques were developed.

(1) Technique for Transporting Furnace Blocks by Air Caster

At Chiba No. 6 BF, a space of 15 m was required between furnace blocks in order to transport blocks with a length of 30 m on the transporting trucks. However, at Kurashiki No. 4 BF, the space between the blocks was limited to 3 m. Therefore, air casters were adopted, as this equipment is small in scale and has a large load capacity. A seal for an air pressure of 0.35 MPa and a flat concrete foundation with strength exceeding a foundation load of 35 t/m<sup>2</sup> are assumed

as conditions when air casters are to be employed. However, the following techniques were developed, shortening the construction period.

(a) The ground was prepared by laying steel plates 25 mm in thickness over rolling compacted ballast. This enabled stable floating of the air casters, verifying the fact that this method satisfies caster use conditions.

(b) The flatness accuracy of the ground during use of the air casters was approximately 30 mm due to the limitations on the flatness of rolling compacted ballast and relative settlement of the ground. In order to follow these changes, a rotating support structure was adopted in the air caster frame (Fig. 10).

(2) Use of Fixed Lifting Equipment

A fixed arrangement was adopted for the lifting equipment used in hoisting the furnace blocks. This

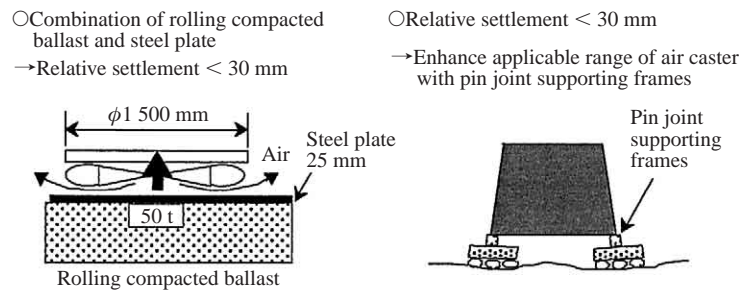

Fig.10 Technology of using foundationless air caster

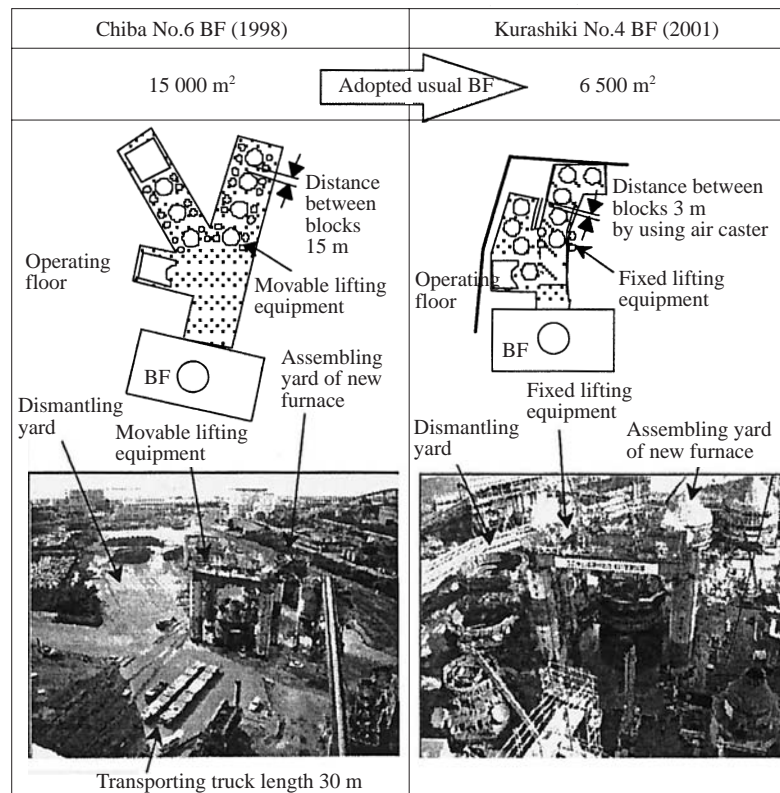

Fig.11 Comparison of revamping area



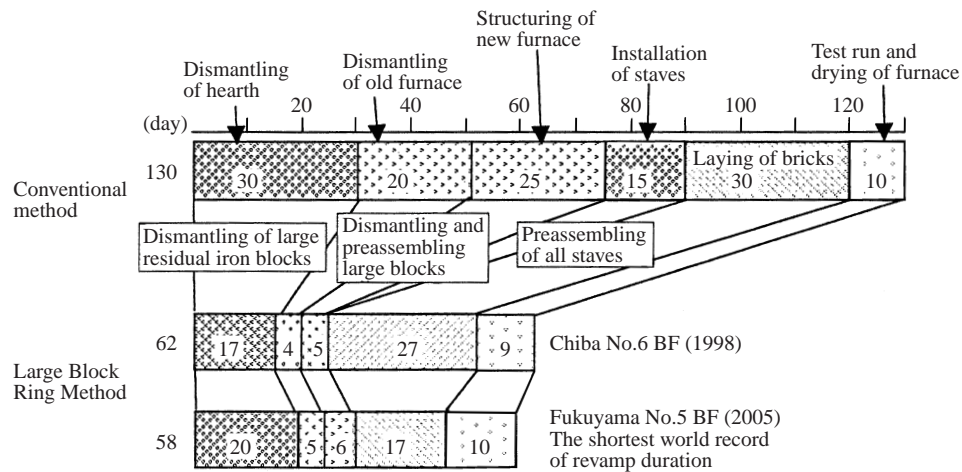

Fig. 12 Duration of revamps using conventional and new method

was achieved by transporting the blocks from the assembly yard to the lifting equipment, and eliminated the need to move the lifting equipment, greatly reducing construction space requirements (Fig. 11).

These space-saving techniques make it possible to apply the Large Block Ring Method widely to general blast furnaces, and were also adopted at Kurashiki No. 2 BF.

## 6. Benefits of Development of Large Block Ring Method

The benefits of the Large Block Ring Method which was realized by this development may be summarized by the following (1) through (3):

- (1) Reduction of the revamping period by half
- (2) Intrinsic safety of work
- (3) Extension of blast furnace life by improved accuracy in furnace body construction

The factors in the one-half reduction in the revamping period can be understood from Fig. 12, which shows a comparison of the respective processes in the Large Block Ring Method and the conventional method. In particular, the old furnace body dismantling process, new mantle assembly process, and stove installation process were reduced to 1/6 that with the conventional method.

Where safety is concerned, because the furnace body dismantling/assembly methods are radically changed in the Large Block Ring Method, work in high places and cramped quarters can be reduced by half in comparison with the conventional method. In addition, dynamiting work accompanying dismantling of the residual iron

could also be greatly reduced.

## 7. Conclusion

JFE Steel developed the Large Block Ring Method for blast furnace revamping and achieved a short-term revamping of 62 days, or one-half of the time required with the conventional method, during the revamping of Chiba No. 6 BF in 1998. As a result of the development of space-saving techniques for the Large Block Ring Method, short-term revamps were also realized at Kurashiki No. 4 BF and Kurashiki No. 2 BF using the same method. Although Fukuyama No. 5 BF is JFE Steel's largest blast furnace, the company set a new world's record for short-term revamping of 58 days at this plant by developing additional techniques for shortening the revamping period. Now the revamp at JFE Steel is the Fukuyama No. 4 BF revamping project, which started 22 Feb. in 2006. In addition to the Large Block Ring Method for the furnace body, JFE Steel applied a challenging new method of large-block dismantling/assembly to the charging equipment as a further evolution of its short-term revamping method.

## References

- 1) Fujita, M.; Kojima, H.; Marushima, H.; Kawai, T. *Iron and Steel Engineer*. 1999-06, p. 38-42.
- 2) Fujita, M.; Kojima, H.; Marushima, H.; Matsumoto, T.; Yokogawa, A. *La Revue de Metallurgie*. 1999-03, p. 350-357.
- 3) Matsuda, K.; Mashino, Y. *Kawasaki Steel Giho*. vol. 32, no. 3, 2000, p. 194.
- 4) Iwata, K.; Morimoto, T.; Kanaya, H.; Ichihara, I.; Fujita, M.; Kiyohara, S. *Kawasaki Steel Giho*. vol. 15, no. 3, 1983, p. 193-200.