



Process sensors

Precise compressed air measurement for efficient energy management.



Flow sensors / flow meters



Exact allocation of energy costs due to precise consumption measurement

Improvement of energy efficiency via leakage monitoring

The basis for a comprehensive energy management system according to DIN EN ISO 50001

Pressure monitoring thanks to the integrated pressure sensor

⌚ Different process values being indicated simultaneously removes the need for multiple instruments



“All-in-one sensor” reduces costs

The SD compressed air meter is a real all-rounder. Thanks to the additionally integrated sensors for pressure and temperature, the user can see four process values (flow rate, pressure, temperature and total consumption) at a glance, which provide information about the energy efficiency of his system. In addition to the inline version, a screw-in version is also available for pipes from 14 to 254 mm diameter.

Compressed air monitoring at a glance

Integration of the SD into the maintenance unit of existing or new installations provides additional advantages: The process values of compressed air in industrial use can be effectively monitored in common compressed-air networks via the integrated TFT display, which allows for selection between four individually adjustable graphic layouts. The process values can also be transmitted via IO-Link.



Improvement of energy efficiency due to the integrated leakage monitoring in the installation

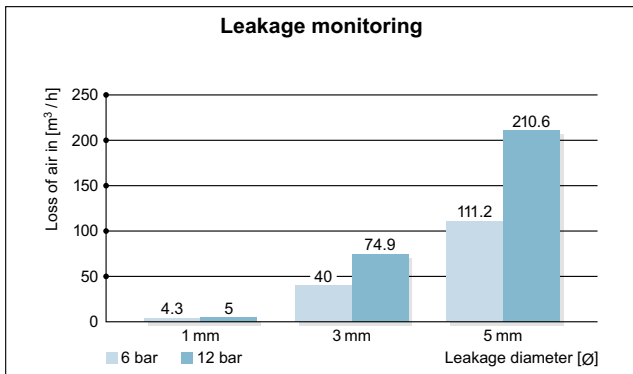

The SD's precise flow monitoring allows for leakage detection and energy cost savings. In addition, the unit's high repeatability enables exact allocation of the costs of compressed air to the respective production line as well as optimised product cost calculation.

Efficient monitoring of the operating pressure

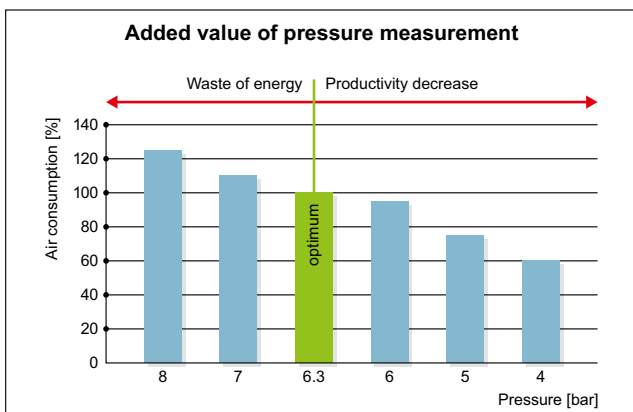

Due to the integrated pressure measurement the SD offers the possibility to monitor the general operating pressure of the compressed air system. But also a falling pressure, for example caused by dirty filter systems, can be detected.

The basis for a comprehensive energy management system according to DIN EN ISO 50001

Following the EU directive on energy efficiency DIN EN ISO 50001, all member states have undertaken to achieve energy savings.

The requirement for obtaining energy tax reductions is the implementation of an energy management system. Combining the new SD compressed air meter with regular DAkkS calibrations provides the optimum basis for this.

* Applies to the specified article(s) and must be requested when ordering the sensor. Subsequent orders are only possible if the device is returned.

Measuring range [Nm³/h]	Medium	Process connection	Order no.
0.05...15	air	G 1/4 (DN8)	SD5500
0.25...75	air	R 1/2 (DN15)	SD6500
0.8...225	air	R 1 (DN25)	SD8500
1.4...410	air	R 1 1/2 (DN40)	SD9500
2.5...700	air	R 2 (DN50)	SD2500
0.3...26260	air	G 1	SD1540

Calibration certificate for flow sensors (SD)*

ISO calibration (6 calibration points)	ZC0020
DAkkS calibration (6 calibration points)	ZC0075

Common technical data Type SD

Flow

Measuring range	[Nm³/h]	0.05...2110
Accuracy	[%]	± (2.0 MV + 0.5 VMR)
Repeatability	[%]	± (6.0 MV + 0.6 VMR)
Response time	[s]	(0.8 MV + 0.2 VMR) ± (1.5 MV)

Temperature

Measuring range	[°C]	-10...60
Accuracy	[K]	± 0.5
Response time T09	[s]	0.5

Pressure

Measuring range	[bar]	-1...16
Linearity error	[%]	< ± 0.5 (BFSL)
Repeatability	[%]	± 0.2
Response time	[s]	0.05

Output signal

Switching output, analogue output, pulse output, IO-Link (configurable)

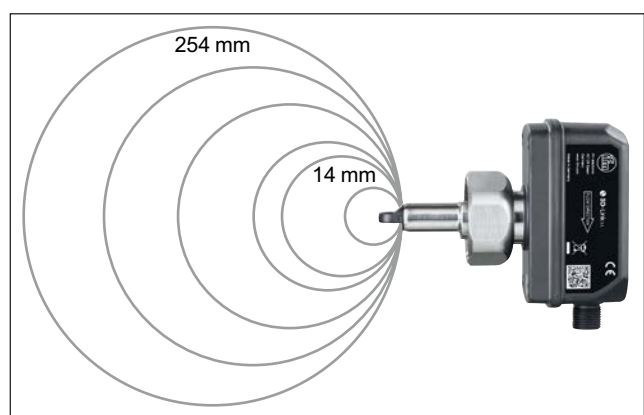

Depending on the pipe diameter, the sensor outputs the consumption in either European or American units.

For further interesting information go to: ifm.com/gb/compressed-air-meter