

# **USER'S MANUAL**

## **VFD Customer Pole Display**

---

48200530  
March 2002, V1.1

# Preface & Contents

This user's manual illustrated how to install VFD Customer Pole Display and its technical settings. The Customer Pole Displays have integrated type for bundling POS PC system and stand alone type as well, the ideal products for Point-Of-Sale solutions.

## **FCC Notice**

### **Federal Communications Commission (FCC) Radio Frequency Interference Statement**

This device complies with part 15 of the FCC Rules. Operation is subject to the following two conditions; (1) This device may not cause harmful interference, and (2) this device must accept any interference received, including interference that may cause undesired operation.

## **COPYRIGHT & TRADEMARK**

All rights reserved. The information contained in this guide has been validated and reviewed for accuracy. No patent liability is assumed with respect to the use of the information contained herein. While every precaution has been taken in the preparation of this guide, the Manufacturer assumes no responsibility for errors or omissions.

No part of this publication may be reproduced, stored in a retrieval system, or transmitted in any form or by any means, electronic, mechanical, photocopying, recording, or otherwise, without the prior written permission of Manufacturer.

General Notice: All the company names used herein are for identification purposes only and may be trademarks of their respective companies.

## **NOTICE**

The contents of this manual are subject to change without notice.

POS7300 VFD Customer Display (V1.1)  
Part no. 48200530

# Contents

<b>1. FEATURES .....</b>	<b>1</b>
<b>2. GENERAL SPECIFICATION.....</b>	<b>2</b>
<b>3 UNPACKING AND CHECKING THE PARTS .....</b>	<b>3</b>
3.1 VFD POLE DISPLAY FOR 720/750 MONITOR.....	3
3.2 VFD POLE DISPLAY FOR 800cx SERIES.....	6
3.3 VFD POLE DISPLAY FOR 800cx SERIES.....	6
3.4. POLE DISPLAY FOR 800cx SERIES.....	6
3. 5 STAND ALONE VFD POLE DISPLAY .....	7
<b>4. INTERFACE .....</b>	<b>8</b>
4.1. VFD POLE DISPLAY FOR 720/750 MONITOR.....	8
4.2 VFD POLE DISPLAY FOR 800cx SERIES.....	14
4.3 VFD POLE DISPLAY FOR 800cx SERIES.....	14
4.4. VFD POLE DISPLAY FOR 800cx SERIES .....	14
4. 5 STAND ALONE VFD POLE DISPLAY .....	15
4.5.1. <i>Specifications</i> .....	15
4.5.2. <i>The communication flow</i> .....	15
4.5.3. <i>Interface</i> .....	16
<b>5. DIP SWITCH AND SOFTWARE SETTING .....</b>	<b>18</b>
5.1 COMMAND TYPE SELECTION.....	18
5.2 BAUD RATE SELECTION.....	18
5.3 PARITY CHECK SELECTION.....	18
5.4 DEMO MODE SELECTION.....	18
5.4 INTERNATIONAL CHARACTER SET .....	19
5.5 SELF-TEST .....	19
5.6. SOFTWARE STATUS SETTING.....	20
5.6.1. <i>Baud rate</i> .....	20
5.6.2 <i>International character set</i> .....	20
5.6.3 <i>Command type select</i> .....	21
5.6.4 <i>Reset EEPROM</i> .....	21
5.6.5 <i>Save data for demo display</i> .....	22
5.6.6 <i>Run Demo message</i> .....	22
5.6.7 <i>Set Communication parity</i> .....	23
5.6.8 <i>Show VFD Firmware Version</i> .....	23
5.6.9 <i>Save title data to EEPROM</i> .....	23
<b>6. COMMAND LIST TABLE .....</b>	<b>24</b>

<b>7. COMMAND</b> .....	<b>27</b>
7.1. POS7300 SERIES COMMAND SET .....	27
7.2 CD5220 STANDARD MODE COMMAND LIST .....	28
7.3 UTC STANDARD MODE COMMAND LIST .....	32
7.4 UTC ENHANCED MODE COMMAND LIST .....	32
7.5 AEDEX MODE COMMAND LIST .....	33
7.6 ADM787/788 MODE COMMAND LIST .....	33
7.7 DSP-800 MODE COMMAND LIST .....	34
7.8 EPSON ESC/POS COMMAND LIST .....	35
<b>8. CHARACTER SET</b> .....	<b>38</b>
8.1 INTERNATIONAL CHARACTER SETS.....	38
8.2 USA, STANDARD CHARACTER SETS (20H – 7EH) .....	39
8.3 PAGE 0 (PC437: USA, STANDARD EUROPE) (80H – FFH) .....	39
8.4 PAGE 1 (KATAKANA) (80H – FFH).....	40
8.5 PAGE 2 (PC850: MULTILINGUAL ) (80H – FFH) .....	40
8.6 PAGE 3 (PC860: PORTUGUESE) (80H – FFH) .....	41
8.7 PAGE 4 (PC863: CANADIAN-FRENCH) (80H – FFH).....	41
8.8 PAGE 5 (PC865: NORDIC) (80H – FFH) .....	42
8.9 PAGE 6 (SLAVONIC) (80H – FFH).....	42
8.10 PAGE 7 (RUSSIA) (80H – FFH) .....	43
<b>9.COMMAND DETAILS</b> .....	<b>44</b>
9.1 OVERWRITE MODE.....	44
9.2 VERTICAL SCROLL MODE.....	44
9.3 HORIZONTAL SCROLL MODE .....	44
9.4 SET THE STRING DISPLAY MODE, AND WRITE STRING TO DISPLAY .....	44
9.5 UPPER LINE MESSAGE SCROLL CONTINUOUSLY.....	44
9.6 MOVE CURSOR LEFT .....	45
9.7 MOVE CURSOR RIGHT.....	45
9.8 MOVE CURSOR UP.....	45
9.9 MOVE CURSOR DOWN.....	45
9.10 MOVE CURSOR TO HOME POSITION.....	46
9.11 MOVE CURSOR TO LEFT -MOST POSITION.....	46
9.12 MOVE CURSOR TO RIGHT -MOST POSITION .....	46
9.13 MOVE CURSOR TO BOTTOM POSITION.....	46
9.14 MOVE CURSOR TO SPECIFIED POSITION .....	46
9.15 INITIALIZE DISPLAY .....	46
9.16 RESET THE WINDOW .....	46
9.17 CLEAR DISPLAY SCREEN, AND CLEAR STRING MODE.....	46
9.18 CLEAR CURRENT LINE, AND CANCEL STRING MODE.....	47
9.19 BRIGHTNESS ADJUSTMENT .....	47
9.20 SET CURSOR ON OR OFF .....	47
9.21 SET USER-DEFINED CHARACTERS.....	47

9.22 RESET USER DEFINED CHARACTER SET .....	47
9.23 CANCEL USER DEFINED CHARACTERS.....	47
9.24 STORE THE USER DEFINED CHARACTER INTO EEPROM .....	47
9.25 RESTORE THE USER DEFINED CHARACTER FROM EEPROM .....	48
9.26 CHARACTER FONT FORMAT .....	48
<b>10. CONTROL CODE SET .....</b>	<b>49</b>

# 1. Features

- (1) Data can be display on 20 columns x 2 lines.
- (2) Blue–green color and large character are easy to see
- (3)The DIP switches setting emulate commands mode, baud rate and international character.
- (4) Command emulation modes include POS7300/ CD5220 II/ ADM787/ UTC / AEDEX/ Epson/ DSP800.
- (5) User' s-defined character and message can be downloaded.
- (6) Display area can be controlled by window function.
- (7) Provides an interface based in RS-232C, and RS232C baud rate from 4800 to 38400 bps.
- (8) Reverse characters can be specified using the Epson command set.
- (9) Support software has facility for designing user-defined characters and downloading setup parameters to the display.

## 2. General Specification

NO	ITEM	DESCRIPTIONS
1	Display method	Vacuum fluorescent display
2	Number of character	40 characters (20 columns x 2 lines)
3	Character font	5 x 7 Dot matrix
4	Display color	Blue green
5	Brightness	700 cd
6	Character type	96 alphanumeric 13 kinds of international character set 1 kind of user define character
7	Character size	9.0mm x 5.25mm
8	Power supply	9 - 35VDC
9	Power consumption	3 - 6 W
10	Operating Temperature	5 - 45
11	Operating Humidity	30%-85%
12	Storage Temperature	-10 - 55
13	Storage Humidity	10%-85%
14	Data transmission	Serial
15	Synchronization	Asynchronous
16	Handshaking	DTR / DSR
17	Signal level	MARK = -3 to -15 V (logic "1") SPACE = +3 to +15 V (logic "0")
18	Baud rates	4800,9600,19200,38400 bps
19	Parity	None, even
20	Bit length	8 bits
21	Stop bits	1 or more

## 3 Unpacking and Checking the Parts

Please make sure following parts are found in the customer display box.

### 3.1 VFD Pole Display for 720/750 Monitor

VFD Pole Display For 720/750 Monitor

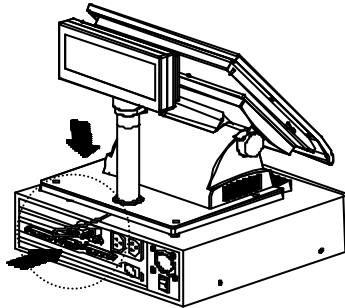

Figure :720 with 300dx PC and Pole Display

The parts of the Pole Display kits: (Part no. P07304)

- (1) Pole Display Module
- (2) Flat Cable (RJ-45 to DB-9F flat cable connector )
- (3) Installation Guide
- (4) Two pieces of pole support (22cm x 1, 9cm x 1)
- (5) Pole Display cover kit



### 3..4. Pole Display for 800cx Series

VFD Pole Display for 800cx series

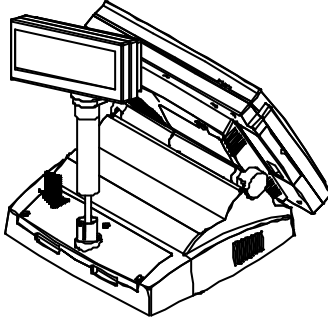

The parts of pole display kits: (Part no. P07308)

- (1) Pole Display Module
- (2) Flat Cable (RJ-45 to DB-9F flat cable connector)
- (3) Installation Guide
- (4) Two pieces of pole support (22cm x 1, 9cm x 1)
- (5) Pole Display cover kit

Flat Type VFD Customer Display for 800cx

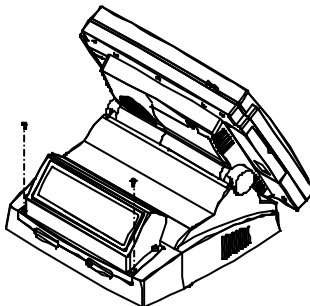

The parts of pole display kits: (Part no. P07307)

- (1) Pole Display Module
- (2) Flat Cable (RJ-45 to DB-9F flat cable connector)
- (3) Installation Guide

### 3. 5 Stand Alone VFD Pole Display

Stand Alone VFD Customer Pole Display (Part no. P07303)

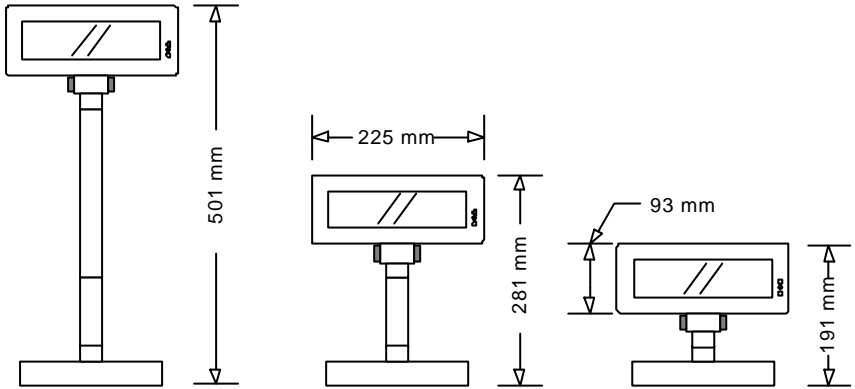

The parts of pole display kits : (Part no.P07303 )

- (1) Pole Display Module
- (2) Flat Cable (DB-9P to DB-9P flat cable connector)
- (3) Base Unit
- (4) Two pieces of pole support (1x22cm, 1x9cm)
- (5) User' s manual
- (6) Power Adapter

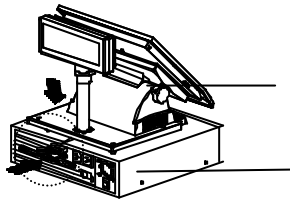

P 720 Monitor

P 300dx PC

Set jumpers on 300dx mainboard

COM1	JP4	1-2 (Default)	Data Line
		3-4	+5V
		5-6	+12V
COM2	JP3	1-2(Default)	Data Line
		3-4	+5V
		5-6	+12V
COM3	JP9	1-2(Default)	Data Line
		3-4	+5V
		5-6	+12V
COM4	JP5	1-2(Default)	Data Line
		3-4	+5V

## 4.4. VFD Pole Display for 800cx series

1. Connect flat cable DB-9P end connector to 800cx serial port COM4. If COM 4 has been used by other device, please use COM1, COM2, or COM3 serial port.

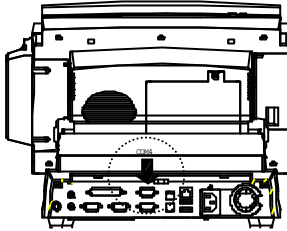
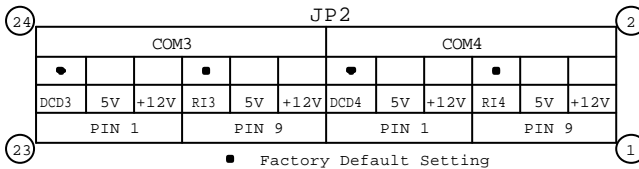
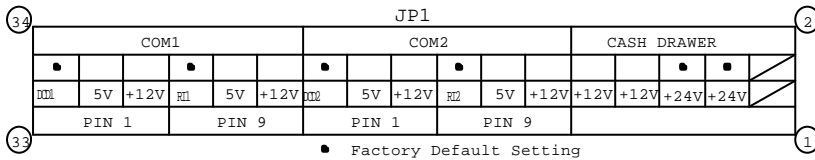

Figure: 800cx rear view

2. Pole Display Jumper setting (on the base of 800cx terminal)

- (1). Set JP2 com4 port Pin 1-2 at +12V or Pin 7-8 at +12V.
- (2). If com4 has been used, select com1, com2, or com3 for Pole Display.
- (3). Below is the jumper setting label on the base of 800cx terminal.



## 4. 5 Stand Alone VFD Pole Display

### 4.5.1. Specifications

Data transmission:	Serial
Synchronization:	Asynchronous
Handshaking:	DTR / DSR
Signal level:	MARK = -3 to -15 V (logic "1") SPACE = +3 to +15 V (logic "0")
Baud rates:	4800,9600,19200,38400 bps
Parity:	None, even
Bit length:	8 bits
Stop bits:	1 or more

### 4.5.2. The communication flow

Data flow:	PC/host to display, Display to printer, Printer to PC/host
Handshaking flow:	Display to PC/host, printer to display, PC/host to printer

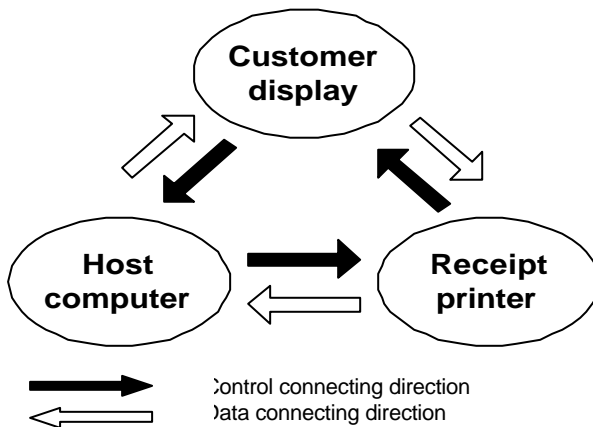

**Note:** There are 200 bytes resident buffer in the display for pass data to printer. If PC/host keep transmitting the data to printer when the display inactive DTR or RTS, data will be lost.

### 4.5.3. Interface

Below illustrate the configuration of Stand Alone VFD Pole Display base.

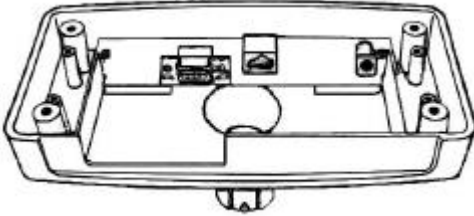
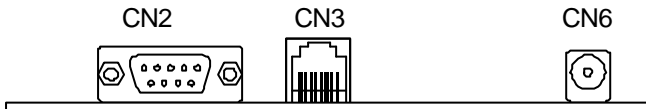

Figure of Stand Alone Pole Display Base

Interface connector on the bottom of Pole Display Base (standard )



CN2: RS-232C connects to PC/Host

CN3: Connect to display panel

CN6: Power supply connector

CN1,CN4, CN5: No used

Power Supply Connectors

CN6 / Connector type: DC jack (5.5/2.1)

Interface connector on the bottom of Pole Display Base (option )

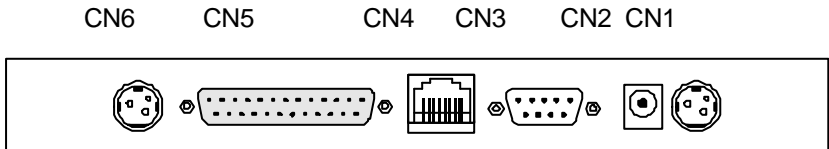

CN2: Power input connector from adapter (range from 9-35VDC,  
Manufacture offer +12V power adapter)

CN3: RS-232C connect to printer (Reserved)

CN4: Connect to display panel

CN5: RS-232C connect to PC/Host

CN1,CN6: 24Vdc power supply pass-through connects (option)

Pin assignment

No	Signal
+	Vin
-	GND



RS232C link to PC/HOST connector  
CN2 / Connector type: D-sub 9 pin female



Pin assignment

No	Signal	Direction	Function description
2	RXD	From PC/Host to display	Receive data
3	TXD	From printer to PC/Host	Printer status data
4	DSR	From PC/Host to printer	PC/Host ready signal
5	GND	-	Signal ground
6	DSR	From display to PC/Host	Display/printer ready signal
8	DSR	From display to PC/Host	Display/printer ready signal

RS232C link to printer connector

CN1 / Connector type: Phone-jack 10P/8C



Pin assignment

No	Signal	Direction	Function description
4,5	GND	-	Signal ground
6	DTR	From PC/Host to printer	PC/Host ready signal
7	DSR	From printer to display	Printer ready signal
8	TXD	From display to printer	Printing data
9	RXD	From printer to PC/Host	Printer status data

Display penal connector

CN3 / Connector type: Phone-jack 10P/8C



Pin assignment

No	Signal	Direction	Function description
2,3	Vin	-	Power 9 – 33 Vdc
4,5	GND	-	Signal ground
6	DSR	From Printer to Display	Printer ready signal
7	DTR	From Display to PC/Host	Display ready signal
8	RXD	From PC/Host to Display	Display/Printing data signal
9	TXD	From Display to Printer	Printer status data signal



## 5. Dip Switch and Software Setting

### 5.1 Command type selection

SW1	SW2	SW3	Command type	Default
ON	ON	ON	POS7300	*
OFF	ON	ON	ESC/POS	
ON	OFF	ON	ADM 787	
OFF	OFF	ON	DSP800	
ON	ON	OFF	AEDEX	
OFF	ON	OFF	UTC/P	
ON	OFF	OFF	UTC/S	
OFF	OFF	OFF	CD5220	

### 5.2 Baud rate selection

SW8	SW9	Baud rate (bps)	Default
ON	ON	4800	
OFF	ON	9600	*
ON	OFF	19200	
OFF	OFF	38400	

### 5.3 Parity check selection

SW10	Parity check	Default
ON	None-parity	*
OFF	Even-parity	

### 5.4 Demo Mode selection

SW11	Show demo string	Default
ON	Enable	*
OFF	Disable	

## 5.4 International character set

SW4	SW5	SW6	SW7	Character set	Code table ( 80H-FFH)
ON	ON	ON	ON	*default U.S.A.	PC-437(USA, standard Europe)
OFF	ON	ON	ON	FRANCE	PC-850(multilingual)
ON	OFF	ON	ON	GERMANY	PC-850(multilingual)
OFF	OFF	ON	ON	U.K.	PC-850(multilingual)
ON	ON	OFF	ON	DENMARK I	PC-850(multilingual)
OFF	ON	OFF	ON	SWEDEN	PC-850(multilingual)
ON	OFF	OFF	ON	ITALY	PC-850(multilingual)
OFF	OFF	OFF	ON	SPAIN	PC-850(multilingual)
ON	ON	ON	OFF	JAPAN	Katakana
OFF	ON	ON	OFF	NORWAY	PC-850(multilingual)
ON	OFF	ON	OFF	DENMARK II	PC-850(multilingual)
OFF	OFF	ON	OFF	SLAVONIC	
ON	ON	OFF	OFF	RUSSIA	
OFF	ON	OFF	OFF	U.S.A	PC860 (Portuguese)
ON	OFF	OFF	OFF	Not used	
OFF	OFF	OFF	OFF	Used define pattern from EEPROM	

## 5.5 Self-test

SW11	function
ON	Power on self-test
OFF	No test

\* **SW12** is reserved

## 5.6. Software Status Setting

When system POWER ON, there is no need to turn off to modify Command Type, Baud Rate, Parity, Demo Mode and International Character. To re-set DIP Switch to various Command Type under the following list of Command to modify the setting. The setup value will be stored in the EEPROM.

When DIP Switch is OFF. Next time the system POWER ON previous setup value will be the default value and no need to modify.

### 5.6.1. Baud rate

**STX 05 B n ETX** /Set baud rate and keep it with EEPROM/

ASCII Format STX 05 B n ETX

Dec. Format [02][05][66] n [03]

Hex. Format [02h][05h][42h] n [03h] 30h n 34h

Description Change the display communication baud rate.

The baud rate setting can be selected from 4800 to 38400.

N	Baud rate
30h	4800
31h	9600
32h	19200
33h	38400

### 5.6.2 International character set

**STX 05 S n ETX** /Change international character set/

ASCII Format STX 05 S N ETX

Dec. Format [02][05][83] n [03]

Hex. Format [02h][05h][53h] n [03h] 30h n 3fh

Description Change the display international character font .A total of 16 different character fonts to select form. The setting function will be saved to EEPROM.

N	International font	n	International font
30h	U.S.A.	38h	JAPAN
31h		39h	NORWAY
32h	GERMANY	3Ah	DENMARK II
33h	U.K.	3Bh	SLAVONIC
34h	DENMARK I	3Ch	RUSSIA
35h	SWEDEN	3Dh	U.S.A.
36h	ITALY	3Eh	Not used
37h	SPAIN	3Fh	User define pattern

### 5.6.3 Command type select

**STX 05 C n ETX** /Change command type/

ASCII Format STX 05 C n ETX

Dec. Format [02][05][67] n [03]

Hex. Format [02h][05h][43h] n [03h] 30h n 37h

Description This command will change the command type and initialize the display.

The display emulation mode is based on DSP800/ESC/ADM787/POS7301/AEDEX/UTC/CD5220 mode. The setting function will be saved to EEPROM.

N	Command type	n	Command type
30h	POS7300	34h	AEDEX
31h	ESC/POS	35h	UTC/P
32h	ADM 787	36h	UTC/S
33h	DSP800	37h	CD5220

### 5.6.4 Reset EEPROM

**STX 05 07 n ETX** /Reset EEPROM/

ASCII Format STX 05 07 n ETX

Dec. Format [02][05][07][n][03]

Hex. Format [02h][05h][07h][n][03h]

Description This command will reset the content of EEPROM (e.g. Demo scroll data, user-define character)

N	Description
31h	Clear all EEPROM contents
32h	Clear upper line data message
33h	Clear lower line data message

### 5.6.5 Save data for demo display

**STX 05 L n m ETX** /Save demo message to EEPROM/  
ASCII Format STX 05 L n m ETX  
Dec. Format [02][05][76] n m [03]  
Hex. Format [02h][05h][4Ch] n m [03h]  
Description Save demo message for upper line and bottom  
line  
n = 31h save data message for upper line  
n = 32h save data message for lower line  
m=data message ; the maximum data character  
is under 200

### 5.6.6 Run Demo message

**STX 05 L n m ETX** /Run demo message/  
ASCII Format STX 05 D 08 ETX  
Dec. Format [02][05][68][08][03]  
Hex. Format [02h][05h][44h][08][03h]  
Description Run demo message for the display

### 5.6.7 Set Communication parity

**STX 05 P n ETX** /Parity check selection/  
ASCII Format STX 05 P n ETX  
Dec. Format [02][05][80] n [03]  
Hex. Format [02h][05h][50h] n [03h] n=30h,31h  
Description Change the display communication parity. Set 8 data bit and the parity set for even or non-parity.

N	Parity check
30h	None-parity
31h	Even-parity

### 5.6.8 Show VFD Firmware Version

**STX 05 V 01 ETX** /Show VFD Firmware Version/  
ASCII Format STX 05 V 01 ETX  
Dec. Format [02][05][86][01][03]  
Hex. Format [02h][05h][56h][01h][03h]  
Description Show VFD firmware version

### 5.6.9 Save title data to EEPROM

**STX 05 T 01 ETX** /Save title data to EEPROM/  
ASCII Format STX 05 T 01 ETX  
Dec. Format [02][05][84][01][03]  
Hex. Format [02h][05h][54h][01h][03h]  
Description Save title data to EEPROM

## 6. Command List Table

Table –1

	I2 POS7300	PARTNER CD5220	EPSON D101	JTC/S	JTC/P	AEDEX	ADM788	GIGA DSP800
Move cursor right	<input type="radio"/>	<input type="radio"/>	<input type="radio"/>					
Move cursor left	<input type="radio"/>	<input type="radio"/>	<input type="radio"/>					
Move cursor up	<input type="radio"/>	<input type="radio"/>	<input type="radio"/>					
Move cursor down	<input type="radio"/>	<input type="radio"/>	<input type="radio"/>					
Move cursor to right-most position	<input type="radio"/>	<input type="radio"/>	<input type="radio"/>					
Move cursor to left-most position	<input type="radio"/>	<input type="radio"/>	<input type="radio"/>					
Move cursor to home position	<input type="radio"/>	<input type="radio"/>	<input type="radio"/>					
Move cursor to bottom position		<input type="radio"/>	<input type="radio"/>					
Move cursor to specified position	<input type="radio"/>	<input type="radio"/>	<input type="radio"/>					<input type="radio"/>
Clear display screen	<input type="radio"/>	<input type="radio"/>	<input type="radio"/>	<input type="radio"/>			<input type="radio"/>	
Clear cursor line	<input type="radio"/>	<input type="radio"/>	<input type="radio"/>					
Brightness adjustment		<input type="radio"/>	<input type="radio"/>					<input type="radio"/>
Blink display screen	<input type="radio"/>	<input type="radio"/>	<input type="radio"/>					<input type="radio"/>
Initialize display	<input type="radio"/>	<input type="radio"/>	<input type="radio"/>					<input type="radio"/>
Select character code table		<input type="radio"/>	<input type="radio"/>					
Select international character set		<input type="radio"/>	<input type="radio"/>					<input type="radio"/>
Select/cancel reverse character			<input type="radio"/>					
Overwrite mode	<input type="radio"/>	<input type="radio"/>	<input type="radio"/>	<input type="radio"/>				
Vertical scroll mode	<input type="radio"/>	<input type="radio"/>	<input type="radio"/>	<input type="radio"/>				
Horizontal scroll mode	<input type="radio"/>	<input type="radio"/>	<input type="radio"/>					
Define download characters		<input type="radio"/>	<input type="radio"/>					<input type="radio"/>
Delete downloads characters		<input type="radio"/>	<input type="radio"/>					<input type="radio"/>
Select/cancel download character set		<input type="radio"/>	<input type="radio"/>					
Set/cancel the window range		<input type="radio"/>	<input type="radio"/>					
Select peripheral device		<input type="radio"/>	<input type="radio"/>					<input type="radio"/>
Set starting/ending position of maro definition			<input type="radio"/>					
Execute and quit macro			<input type="radio"/>					
Execute self -test		<input type="radio"/>	<input type="radio"/>					<input type="radio"/>
Display time			<input type="radio"/>		<input type="radio"/>	<input type="radio"/>		
Display time continuously			<input type="radio"/>					
Display position				<input type="radio"/>				
Cursor on/off	<input type="radio"/>	<input type="radio"/>	<input type="radio"/>	<input type="radio"/>				

Change to UTC enhanced mode				○				
Change to UTC standard mode					○			
Write string to upper line	○	○			○	○		
Write string to lower line	○	○			○	○		
Upper line message scroll continuously	○	○			○	○		
Bottom line message scroll continuously	○							
Message vertical down scroll continuously	○							
Message vertical upper scroll continuously	○							
Carriage return	○			○			○	
Line feed	○			○				
Back space	○			○				
Horizontal tab	○			○				
Command type select		○	○					○



## Table-2

	J2 POS7300	PARTNER CD5220	EPSON D101	JTC/S	JTC/P	AEDEX	ADM788	GIGA DSP800
Upper line message scroll once pass					<input type="radio"/>	<input type="radio"/>		
Change attention code					<input type="radio"/>	<input type="radio"/>		
Two line display					<input type="radio"/>	<input type="radio"/>		
Clear upper line and move cursor to upper left-end position							<input type="radio"/>	
Clear bottom line and move cursor to bottom left-end position							<input type="radio"/>	
Set period to upper line, last n position							<input type="radio"/>	
Set line blinking, upper line	<input type="radio"/>						<input type="radio"/>	
Clear line blinking, upper line	<input type="radio"/>						<input type="radio"/>	
Clear field 1 and move cursor to field 1, first position							<input type="radio"/>	
Clear field 2 and move cursor to field 2,first position							<input type="radio"/>	
Clear display range from n position to m position and move cursor to n position								<input type="radio"/>
Save the current displaying data to n layer for demo display								<input type="radio"/>
Save demo message to EEPROM		<input type="radio"/>						
Store the use define character into EEPROM		<input type="radio"/>	<input type="radio"/>					
Store the use define character from EEPROM		<input type="radio"/>	<input type="radio"/>					
Turn annunciator on/off			<input type="radio"/>					
Specify period			<input type="radio"/>					
Specify comma			<input type="radio"/>					
Specify semicolon (period + comma)			<input type="radio"/>					

# 7. Command

## 7.1. POS7300 series command set

POS7300 Standard Mode Command List

Command	Code (hex)	Function Description
ESC F A .. CR	1B 46 41 [DATA X 40] 0D	Write string to upper line
ESC F B .. CR	1B 46 42 [DATA X 40] 0D	Write string to lower line
ESC F D .. CR	1B 46 44 [DATA X 40] 0D	Upper line message scroll continuously
ESC F O .. CR	1B 46 4F [DATA X 40] 0D	Bottom line message scroll continuously
ESC P x y	1B 50 x y 1 x 20,y=1,2	Move cursor to specified position
ESC _ n	1B 5F n      n=00,01	Set cursor on/off
ESC DC1	1B 11	Overwrite mode
ESC DC2	1B 12	Vertical scroll mode
ESC DC3	1B 13	Horizontal scroll mode
ESC @	1B 40	Initialize display
US MD2 n	1F 02 n      n=01~0Ch	Message vertical down scroll continuously
US MD1 n	1F 01 n      n=01~0Ch	Message vertical upper scroll continuously
US DC1 n	1F 11 n      n=' 1' , ' 2'	Set line blinking N=' 1' up line, n=' 2' low line
US DC2 n	1F 12 n      n=' 1' , ' 2'	Clear line blinking N=' 1' up line, n=' 2' low line
US E n	1F 45 n      n=0~FFh	Blink display screen
NULL H	0 48	Move cursor up
NULL K	0 4B	Move cursor left
NULL M	0 4D	Move cursor right
NULL P	0 50	Move cursor down
NULL G	0 47	Move cursor to left-most position
NULL O	0 4F	Move cursor to right-most position
BS	08	Back space
HT	09	Horizontal tab
LF	0A	Line feed
HOM	0B	Move cursor to home position
CLR	0C	Clear display screen
CR	0D	Carriage return
CAN	18	Clear cursor line , and clear string mode

## 7.2 CD5220 Standard Mode Command List

Command	Code (hex)	Function description
ESC DC1	1B 11	Overwrite mode
US SOH	1F 01	Overwrite mode
ESC DC2	1B 12	Vertical scroll mode
US STX	1F 02	Vertical scroll mode
ESC DC3	1B 13	Horizontal scroll mode
US ETX	1F 03	Horizontal scroll mode
ESC Q A .. CR	1B 51 41 [n]x20 0D	Set the string display mode, write string to upper line.
ESC Q B .. CR	1B 51 42 [n]x20 0D	Set the string display mode, write string to lower line.
ESC Q D .. CR	1B 51 44 [n]xm 0D m40	Upper line message scroll continuously
ESD [ D	1B 5B 44	Move cursor left
BS	08	Move cursor left
ESC [ C	1B 5B 43	Move cursor right
HT	09	Move cursor right
ESC [ A	1B 5B 41	Move cursor up
US LF	1F 0A	Move cursor up
ESC [ B	1B 5B 42	Move cursor down
LF	0A	Move cursor down
ESC [ H	1B 5B 48	Move cursor to home position
HOM	0B	Move cursor to home position
ESC [ L	1B 5B 4C	Move cursor to left-most position
CR	0D	Move cursor to left-most position
ESC [ R	1B 5B 52	Move cursor to right-most position
US CR	1F 0D	Move cursor to right-most position
ESC [ K	1B 5B 4B	Move cursor to bottom position
US B	1F 42	Move cursor to bottom position
ESC b [n]xC8 [m]xC8	1B 62 [n]xC8h [m]xC8h	Save demo message to EEPROM n=Line 1; m=Line 2
ESC # n	1B 23 n (n=30~37)	Command type select
US @	1F 40	Execute self test
US E n	1F 45 n	Blink display mode

### (REMARK)

\*While using command "ESC Q A" or "ESC Q B", other commands can not be used except when using command "CLR" to change operating mode.

\*When using command "ESC Q D", the upper line message will scroll continuously until a new command is received, it will then clear the upper line and move the cursor to the

upper left-end position.

CD5220 Standard Mode Command List-2

Command	Code (hex)	Function description
ESC l x y	1B 6C x y / 1F 24 x y 1x20, y=1,2	Move cursor to specified position
US \$ x y	1F 24 x y 1x20,y=1,2	Move cursor to specified position
ESC @	1B 40	Initialize display
ESC W s x1 x2 y	1B 57 1 x1 x2 y 1x1x220 y=1,2	Set or cancel the window range at horizontal scroll mode
CLR	0C	Clear display screen, and clear string mode
CAN	18	Clear cursor line, and clear string mode
ESC * n	1B 2A n      1 n 4	Brightness adjustment
US X n	1F 58 n      1 n 4	Brightness adjustment
ESC & s n m [a (P1..Pa)]x (m-n+1)	1B 26 1 n m [a(p1..pa)]x(m-n+1) 20 n m FF	Define download characters. A=1-5 p1..p5=row1..row5
ESC ? n	1B 3F n      n=20h~7Fh	Deletes download characters.
ESC % n	1B 25 n      n=00,01	Select/cancel download character set.
ESC _ n	1B 5F n      n=00,01	Set cursor on/off
ESC f n	1B 66 n	Select international fonts, refer *2
ESC c n	1B 63 n	Select fonts, ASCII code or JIS code, refer *3
ESC = n	1B 3D n n=01,02,03,31,32,33	Select peripheral device, display or printer n=01,enable printer n=02,enable display n=03,enable printer, display
ESC s 1	1B 73 01	Store the use define character into EEPROM
ESC d 1	1B 64 01	Store the use define character from EEPROM

\*2: The parameter of international fonts set control by command “ESC f n”

Parameter n	International Font Set
'A	U.S.A.
'G	Germany
'I	Italy
'J	Japan
'U	U.K.
'F	France
'S	Spain
'N	Norway
'W	Sweden
'D	Denmark I
'E	Denmark II
'L	Slavonic
'R	Russia

\*3: The parameter of the code table control by command “ESC c n”

Parameter “n”	International Font Set
'A	Compliance with ASCII code
'J	Compliance with JIS code
'L	Compliance with SLOVONIC code
'R	Compliance with RUSSIA code

### 7.3 UTC standard mode command list

Command	Code (hex)	Function description
BS	08	Back space
HT	09	Horizontal tab
LF	0A	Line feed
CR	0D	Carriage return
DLE	10 n 0 n 28h	Display position
DC1	11	Over write display mode
DC2	12	Vertical scroll mode
DC3	13	Cursor on
DC4	14	Cursor off
US	1F	Clear display
ESC d	1B 64	Change to UTC enhanced mode

### 7.4 UTC enhanced mode command list

Command	Code (hex)	Function description
ESC u A .. CR	1B 75 41 [data x 40] 0D	Upper line display
ESC u B .. CR	1B 75 42 [data x 40] 0D	Bottom line display
ESC u D .. CR	1B 75 44 [data x 40] 0D	Upper line message scroll continuously
ESC u E .. CR	1B 75 45 h h ':' m m 0D h, m = '0' - '9'	Display time
ESC u F .. CR	1B 75 46 [data x 40] 0D	Upper line message scroll Once pass
ESC u H .. CR	1B 75 48 n m 0D 20h n, m	Change attention code
ESC u I .. CR	1B 75 49 [data x 40] 0D	Two line display
ESC RS CR	1B 0F 0D	Change to UTC standard mode

## 7.5 AEDEX mode command list

Command	Code (hex)	Function description
! # 1 ...CR	21 23 31 [data x 40] 0D	Upper line display
! # 2 ...CR	21 23 32 [data x 40] 0D	Bottom line display
! # 4 ...CR	21 23 34 [data x 40] 0D	Upper line message scroll
! # 5 ...CR	21 23 35 h h ':' m m 0D h, m='0'-'9'	Display time
! # 8 ...CR	21 23 38 n m 0D 20H,n,m	Change attention code
! # 9 ...CR	21 23 39 [data x 40] 0D	Two line display
! # 6 ...CR	21 23 36 [data x 40] 0D	Upper line message scroll once pass

## 7.6 ADM787/788 mode command list

Command	Code (hex)	Function description
CLR	0C	Clear display
CR	0D	Carriage return
SLE1	0E	Clear upper line and move cursor to upper left-end position
SLE2	0F	Clear bottom line and move, Cursor to bottom left-end Position
DC0	10 n	Set period to upper line last n position 31H n 37H
DC1	11 n	Set line blinking, upper line n='1' up line, n='2' low line
DC2	12n	Clear line blinking, upper line n='1' up line, n='2' low line
SF1	1E	Clear field 1 and move cursor to field 1, first position
SF2	1F	Clear field 2 and move cursor to field 2, first position



## 7.7 DSP-800 mode command list

Command	Code (hex)	Function descriptions
EOT SOH I n ETB	04 01 49 n 17 n=00~0Fh or 30~3Fh	Select international character set
EOT SOH P n ETB	04 01 50 n 17 n=31h-58h	Move cursor to specified position
EOT SOH C n m ETB	04 01 43 n m 17 31h n m 58h	Clear display range from <u>n</u> position to <u>m</u> position and move cursor to <u>n</u> position
EOT SOH S n ETB	04 01 53 n 17 n=31h-35h	Save current view message to n layer for demo view data
EOT SOH D n m ETB	04 01 44 n m 17 n=31h-4Fh,m=31h-33h	Display the saved demo message
EOT SOH A n ETB	04 01 41 n 17 n=31h-34h	Brightness adjustment
EOT SOH F n ETB	04 01 46 n 17 00h n FFh	Blink display Screen
EOT SOH & n [ px5] ETB	04 01 26 n p1..p5 17, 20h n	Define download characters
EOT SOH ? n ETB	04 01 3F n 17 20h n	Delete download characters
EOT SOH = n ETB	04 01 3D n 17 n='1', '2', '3'	Select peripheral device. n='1',enable printer n='2',enable display n='3',enable printer display
EOT SOH % ETB	04 01 25 17	Initialize display
EOT SOH @ ETB	04 01 40 17	Execute self-test
EOT SOH # n ETB	04 01 23 n 17, n=30~37h	Command type select

## 7.8 EPSON ESC/POS command list

EPSON ESC/POS command list-1

Command	Code (hex)	Function description
HT	09	Move cursor right.
BS	08	Move cursor left.
US LF	1F 0A	Move cursor up.
LF	0A	Move cursor down.
US CR	1F 0D	Move cursor to right-most position.
CR	0D	Move cursor to left-most position.
HOM	0B	Move cursor to home position.
US B	1F 42	Move cursor to bottom position.
US \$ x y	1F 24 x y (x=1~20, y=01,02)	Move cursor to specified position.
CLR	0C	Clear display screen.
US X n	1F 58 n (01 n 04)	Brightness adjustment.
US E n	1F 45 n (n=00~ffh)	Blink display screen.
ESC @	1B 40	Initialize display.
ESC t n	1B 74 n (n=00-0fh)	Select character code table.
ESC R n	1B 52 n (n=00-0fh)	Select international character set.
US r n	1F 72 n (n=00,01)	Select/cancel reverse character.
US MD1	1F 01	Specify overwrite mode.
US MD2	1F 02	Specify vertical scroll mode.
US MD3	1F 03	Specify horizontal scroll mode.
ESC & s n m [a(p1..pa)]x m-n	1B 26 1 n m [a(p1..pa)]x m-n 20<n<=m<=ff	Define download characters. 20<n<=m<=ff a=1-5 p1 .. p5 = row1 .. row5
ESC ? n	1B 3F n (20 n FF)	Delete downloads characters.
ESC % n	1B 25 n (n=0,30,1,31)	Select/cancel download character set.
CAN	18	Clear cursor line
ESC # n	1B 23 n (30h n 38h)	Command type select
US # n m	1F 23 n m, (n=0 or 1,0<m 20)	Turn annunciator on/off
US C n	1F 43 n (n=1,31 then on)	Set cursor on/off
US . n	1F 2E n, n=a displayable character code	Specify period
US , n	1F 2C n, n=a displayable character code	Specify comma
US ; n	1F 3B n, n=a displayable character code	Specify semicolon (period +comma)

EPSON Esc/pos command list

Command	Code (hex)	Function description
ESC W n s x1 y1 x2 y2	1B 57 n s x1 y1 x2 y2 n=1,2,3,4 s=0,1	Specify/cancel the window range. 1<=x1<=x2<=20 1<=y1<=y2<=2
ESC = n	1B 3D n n=1,31,select printer n=2,32,select display n=3,33, select printer, display	Select peripheral device.
US :	1F 3A	Set starting/ending position of macro definition. Ex.: 1F 3A ..... (macro string) ..... 1F 3A
US ^ n m	1F 5E n m 00 (n, m) ff n=Word time m=show string time	Execute and quit macro. It's an interval of n between the two words. It's an interval of m between the two string.
US @	1F 40	Execute self - test
US T h m	1F 54 h m 0<=h<=17h, 0<=m<=3bh	Display time
US U	1F 55	Display time continuously
ESC s 1	1B 73 01	Store define download character to EEPROM
ESC d 1	1B 64 01	Restore user define character from EEPROM

Set international font for ESC/POS (Table 7-11)

n	International font set	n	International font set
0	U.S.A	7	SPAIN
1	FRANCE	8	JAPAN
2	GERMANY	9	NORWAY
3	U.K.	10	DENMARK II
4	DENMARK I	11	SLAVONIC
5	SWEDEN	12	RUSSIA
6	ITALY	15	Reserved

Select code for ESC/POS (Table 7-12)

n	International font set (80H~FFH)
0	Page 0, (PC437: U.S.A., standard Europe)
1	Page 1, (Katakana for Japan)
2	Page 2, (PC850: multilingual)
3	Page 3, (PC860: Portuguese)
4	Page 4, (PC863: Canadian-French)
5	Page 5, (PC865: Nordic)
6	Page 6, (SLAVONIC)
7	Page 7, (RUSSLA)

# 8. Character Set

## 8.1 International Character Sets

		ASCII Code											
Country	Hex Dec	23	24	40	5B	5C	5D	5E	60	7B	7C	7D	7E
		35	36	64	91	92	93	94	96	123	124	125	126
U.S.A	#	\$	@	[	\	]	^	`	{		}	~	
France	#	\$	à	°	ç	§	^	`	é	ù	è	¨	
Germany	#	\$	§	Ä	Ö	Ü	^	`	ä	ö	ü	â	
U.K	£	\$	@	[	\	]	^	`	{		}	~	
Denmark I	#	\$	@	Æ	Ø	Å	^	`	æ	ø	å	~	
Sweden	#	¤	É	Ä	Ö	Å	Ü	é	ä	ö	å	ü	
Italy	#	\$	@	°	\	é	^	ù	à	ò	è	ì	
Spain	Pt	\$	@	ı	Ñ	ı	^	`	¨	ñ	}	~	
Japan	#	\$	@	[	¥	]	^	`	{		}	~	
Norway	#	¤	É	Æ	Ø	Å	Ü	é	æ	ø	å	ü	
Denmark II	#	\$	É	Æ	Ø	Å	Ü	é	æ	ø	å	ü	
Slawie	#	\$	@	[	\	]	^	`	{		}	~	
Russia	#	\$	@	[	\	]	^	`	{		}	~	

## 8.2 USA, Standard Character Sets (20H – 7EH)

	00	01	02	03	04	05	06	07	08	09	0A	0B	0C	0D	0E	0F
20H	SP	!	"	#	\$	%	&	'	(	)	ç	+	,	-	.	/
30H	0	1	2	3	4	5	6	7	8	9	:	;	<	=	>	?
40H	@	A	B	C	D	E	F	G	H	I	J	K	L	M	N	O
50H	P	Q	R	S	T	U	V	W	X	Y	Z	[	\	]	^	_
60H	`	a	b	c	d	e	f	g	h	i	j	k	l	m	n	o
70H	p	q	r	s	t	u	v	w	x	y	Z	{		}	~	SP

## 8.3 Page 0 (PC437: USA, Standard Europe) (80H – FFH)

	00	01	02	03	04	05	06	07	08	09	0A	0B	0C	0D	0E	0F
80H	Ç	ü	é	â	ä	à	å	ç	ê	ë	è	ï	î	ì	Ë	À
90H	É	æ	Æ	ô	ö	ò	û	ù	ÿ	ö	Û	¢	£	¥	Pt	f
A0H	á	í	ó	ú	ñ	Ñ	a	o	ı		¬	½	¼	i	«	»
B0H																
C0H																
D0H																
E0H	á	ß	Ã	ð	Ó	ó	ì	ô	Ô	è	Ù	ä		ø		
F0H		±					÷		°	.			°	²		SP

### 8.4 Page 1 (Katakana) (80H – FFH)

	00	01	02	03	04	05	06	07	08	09	0A	0B	0C	0D	0E	0F
80H	á	â	ã			ç	è	ë	ì	ï	ñ	ó	ô	Õ		
90H	f	§	IE	IR		⊗		<sup>-1</sup>	<sup>2</sup>	<sup>3</sup>	<sup>x</sup>	½	¼		±	
A0H	SP						ㄨ	ㄚ	ㄛ	ㄜ	ㄝ	ㄞ	ㄟ	ㄠ	ㄡ	ㄢ
B0H	一	ア	イ	ウ	エ	オ	カ	キ	ク	ケ	コ	サ	シ	ス	セ	ソ
C0H	タ	チ	ツ	テ	ト	ナ	ニ	ヌ	ネ	ノ	ハ	ヒ	フ	ヘ	ホ	マ
D0H	ミ	ム	メ	モ	ヤ	ユ	ヨ	ラ	リ	ル	レ	ロ	ワ	ン	"	
E0H								←	→			«	»			
F0H	≤	≥						✱	✶		~					

### 8.5 Page 2 (PC850: Multilingual ) (80H – FFH)

	00	01	02	03	04	05	06	07	08	09	0A	0B	0C	0D	0E	0F
80H	Ç	ü	é	â	ä	à	â	ç	ê	ë	è	ï	î	ì	Ä	Å
90H	É	æ	Æ	ô	ö	ò	û	ù	ÿ	ö	Ü	ø	£	Ø	×	f
A0H	á	í	ó	ú	ñ	Ñ	a	o	¿	®	¬	½	¼	¡	«	»
B0H						Á	Â	À	©					¢	¥	
C0H						ã	Ã									¤
D0H	ø	Ð	Ê	Ë	È	ý	í	î	ï					ì	ì	
E0H	ó	ß	ô	ò	õ	Õ	ì	þ	Þ	Ú	Û	Ù	ý	Ý	-	'
F0H	ˆ	±	¾	¶	§	÷	¸		"	ÿ	<sup>1</sup>	<sup>3</sup>	<sup>2</sup>			SP

### 8.6 Page 3 (PC860: Portuguese) (80H – FFH)

	00	01	02	03	04	05	06	07	08	09	0A	0B	0C	0D	0E	0F
80H	Ç	ü	é	â	ã	à	Á	ç	ê	Ê	è	í	Ô	ì	Ã	Â
90H	É	À	È	ô	õ	ò	Ú	ù	ì	Õ	Û	ç	£	Ù	Pt	Ó
A0H	á	í	ó	ú	ñ	Ñ	a	o	ç	Ò	¬	½	¼	¡	«	»
B0H																
C0H																
D0H																
E0H	á	â	Ã	ä	Ó	ó	ì	ô	Ô	è	Ù	ä		ø		
F0H		±					÷		°				n	z		SP

### 8.7 Page 4 (PC863: Canadian-French) (80H – FFH)

	00	01	02	03	04	05	06	07	08	09	0A	0B	0C	0D	0E	0F
80H	Ç	ü	é	â	Â	à	¶	ç	ê	ë	è	ï	î		À	§
90H	É	È	Ê	ô	Ë	ï	û	ù	æ	Ô	Û	ç	£	Ù	Û	f
A0H	í	´	ó	ú	¨	¸	³	¬	î		¬	½	¼	¾	«	»
B0H																
C0H																
D0H																
E0H	á	â	Ã	ä	Ó	ó	ì	ô	Ô	è	Ù	ä		ø		
F0H		±					÷		°		.		n	z		SP



### 8.8 Page 5 (PC865: Nordic) (80H – FFH)

	00	01	02	03	04	05	06	07	08	09	0A	0B	0C	0D	0E	0F
80H	Ç	ü	é	â	ä	à	å	ç	ê	ë	è	ï	î	ì	Ë	Å
90H	É	æ	Æ	ô	ö	ò	û	ù	ÿ	Ö	Ü	ø	£	Ø	Pt	f
A0H	á	í	ó	ú	ñ	Ñ	a	o	ı		¬	½	¼	j	«	»
B0H																
C0H																
D0H																
E0H	á	â	Ã	ð	Ó	ó	ì	ô	Ô	è	Ù	ä		ø		
F0H		±					÷		°		.	n	z			SP

### 8.9 Page 6 (Slavonic) (80H – FFH)

	00	01	02	03	04	05	06	07	08	09	0A	0B	0C	0D	0E	0F
80H	Ç	ü	é	â	ä	ù	æ	ç	Á	ë	ō	õ	î	ÿ	ä	æ
90H	é	Á	í	ô	ö	¼		œ	œ	Ö	Ü			á	õ	è
A0H	á	í	ó	ú	ı	ı	ž	ž	ê	ê		ÿ	è	°	«	»
B0H						á	â		°					ı	ı	
C0H							ã	ã								»
D0H			ã	ë	ã	ò	í	î	ì					p	ù	
E0H	ó	â	ô	ñ	ñ	ò	š	š	à	ú	à		ý	ý	p	
F0H	–		í	i	ç	š	÷	ĩ		¨	ÿ		ø	ø		SP

### 8.10 Page 7 (Russia) (80H – FFH)

	00	01	02	03	04	05	06	07	08	09	0A	0B	0C	0D	0E	0F
80H	À	Á	Â	Ã	Ä	Å	Æ	Ç	É	Ê	Ë	Ì	Í	Î	Ï	
90H	Ð	Ñ	Ò	Ó	Ô	Õ	Ö	×	Ø	Ù	Ú	Û	Ü	Ý	Þ	ß
A0H	à	á	â	ã	ä	å	æ	ç	è	é	ê	ë	ì	í	î	ï
B0H																
C0H																
D0H																
E0H	ð	ñ	ò	ó	ô	õ	ö	÷	ø	ù	ú	û	ü	ý	þ	ÿ
F0H		¥	К	Н	è	У	У	h		´	k	h	è	У	У	SP

## **9.Command details**

### **9.1 Overwrite mode**

In this mode, the cursor will move rightward and begin from the upper left-end position. When the cursor reached the end of the upper line, the cursor will move down to the bottom left-end position to continue. When the cursor reached the end of the bottom line, it will move up the upper left-end position and overwrite the previous characters.

### **9.2 Vertical scroll mode**

In this mode, the cursor will move rightward. The cursor will begin from the upper left-end position until it reached the end of the upper line, the cursor will then move down to the bottom left-end position to continue until it reached the end of the bottom line.

### **9.3 Horizontal scroll mode**

In this mode, the extend of the cursor activity is bond by predefined range, limited to the upper line.(Please refer to Set or cancel window command), where the default window is the whole upper line. The cursor will begin from the left-end of the range and move rightward until it reached the end of the range, to continue, the characters that comes thereafter will start pushing the previous characters leftward from the right-end, scrolling the characters to the left.

### **9.4 Set the string display mode, and write string to display**

Set the string display mode, write to upper or lower line d1 d2 d3 ..... dn {1 n 20} ' A' stands for the upper line, ' B' stands for the lower line, The string display mode will be cancelled and back to last mode after receive CLR or CAN

### **9.5 Upper line message scroll continuously**

The message (previously defined) will scroll continuously in the horizontal direction until a new command is received.

## 9.6 Move cursor left

When the current cursor is at the left-end position, this command operates differently depending on the display mode. Overwrite mode: When the cursor reached the left-end of the lower line, it will continue to the right-end of the upper line, overwrite previous characters.

When it reached the left end of the upper line, it will continue to the right-end of the lower line. Vertical scroll mode: When the cursor reached the left-end of the lower line, the lower line will scroll up and replace the previous upper line, the lower line will be cleared and the cursor will continue to the right end of the lower line. Horizontal scroll mode: The cursor will remain stationary.

## 9.7 Move cursor right

Move the cursor to the right. When the cursor reached the right-end, this command operates differently depending on the display mode. Overwrite mode: When the cursor reached the right-end of the lower line, it will continue to the left-end of the upper line, overwrite previous characters. When it reached the right-end of the upper line, it will continue to the right-end of the lower line. Vertical scroll mode: When the cursor reached the right-end of the lower line, the lower line will scroll up to replace the upper line, the lower line is cleared and ready to continue characters there after. Horizontal scroll mode: The cursor will remain stationary.

## 9.8 Move cursor up

Move the cursor up one line. When the cursor is on the upper line, this command operates differently depending on the display mode. Overwrite mode: The cursor is moved to the same column the lower line. Vertical scroll mode: The characters display on the upper line is scrolled to the lower line, and the upper line is cleared. The cursor will remain at the same position. Horizontal scroll mode: The cursor will remain stationary.

## 9.9 Move cursor down

Move the cursor down one line. When the cursor reached the lower line, this command operates differently depending on the display mode. Overwrite mode: The cursor is moved to the same column on the upper line. Vertical scroll mode: The characters display on the lower line are scrolled to the upper line, and the lower line is cleared. The cursor will remain at

the same position.

Horizontal scroll mode: The cursor will remain stationary.

## **9.10 Move cursor to home position**

The cursor will move to the left-end position of the upper line

## **9.11 Move cursor to left-most position**

The cursor will be moved to the left-end position of the current line.

## **9.12 Move cursor to right-most position**

The cursor will be moved to the right-end position of the current line.

## **9.13 Move cursor to bottom position**

The cursor will be moved to the right-end position on the lower line.

## **9.14 Move cursor to specified position**

The cursor will be moved to the x column on the y line.

## **9.15 Initialize display**

The data in the input buffer will be cleared and reset from default.

## **9.16 Reset the window**

Reset the window on the display. When  $s=0$ , window is cancelled (values:  $x_1$ ,  $x_2$ , and  $y$  are not required.)

When  $s=1$  the window will be reset (values:  $x_1$ ,  $x_2$ , and  $y$  are required.) The  $x_1$  and  $x_2$  set the position of the left column and right column, respectively, of the window. The  $y$  sets the upper line or the lower line of the window.

This function is valid within the horizontal mode.

## **9.17 Clear display screen, and clear string mode**

All the display characters will be cleared, and the string mode will be cancelled.

## 9.18 Clear current line, and cancel string mode

The current line is cleared, and the string mode is cancelled.

## 9.19 Brightness adjustment

Adjust the brightness of the vacuum fluorescent display.

When  $n=3$ , brightness=70%

When  $n=4$ , brightness=100%

## 9.20 Set cursor ON or OFF

When  $n=0$ , cursor is OFF

When  $n=1$ , cursor is ON

## 9.21 Set user-defined characters

The  $n$  defines the beginning character code, and  $m$  defines the ending character code. When only one character is defined, use  $n=m$ . The 'a' denotes the number of dots in the horizontal direction. When  $a < 5$ , the dot pattern for 'a' on the right side of the user-defined characters are padded with spaces  $p_1 \dots p_a$ , the dot data is to defined the characters. This indicates the dot pattern for /a/ in the horizontal direction from the left side.

## 9.22 Reset user defined character set

When  $n=1$ , user-defined characters are selected. When the user-defined characters are not defined by the ESC & command, the internal character set will be displayed.

When  $n=0$ , user-defined characters are cancelled and the international character set is selected.

## 9.23 Cancel user defined characters

User-defined characters are cancelled.

This command cancels the defined characters specified by  $n$ . If specified code is transmitted after the pattern is cancelled, the international character will be displayed.

## 9.24 Store the user defined character into EEPROM

If EEPROM is not supported, this command is ignored.

## 9.25 Restore the user defined character from EEPROM

If EEPROM is not supported, this command is ignored.

## 9.26 Character font format

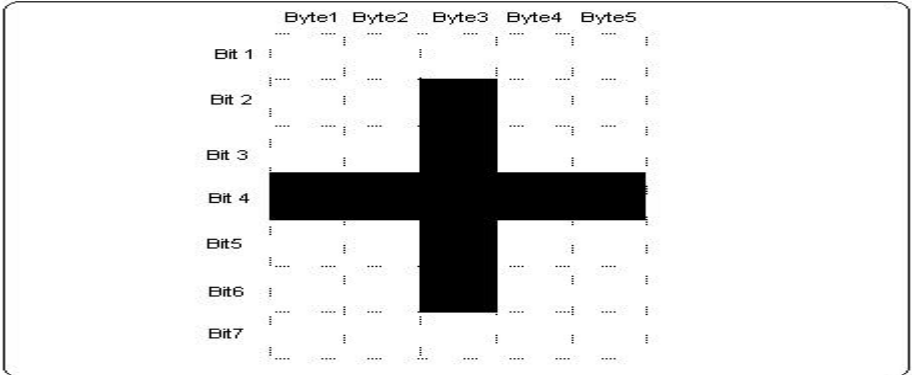

One font consists of 5 bytes' string. The string format is:

Bit	7	6	5	4	3	2	1	0
Byte 1	0	R7C1	R6C1	R5C1	R4C1	R3C1	R2C1	R1C1
Byte 2	0	R7C2	R6C2	R5C2	R4C2	R3C2	R2C2	R1C2
Byte 3	0	R7C3	R6C3	R5C3	R4C3	R3C3	R2C3	R1C3
Byte 4	0	R7C4	R6C4	R5C4	R4C4	R3C4	R2C4	R1C4
Byte 5	0	R7C5	R6C5	R5C5	R4C5	R3C5	R2C5	R1C5

## 10. Control code set

HEX	CODE	HEX	CODE
00H	NULL	10H	DLE
01H	SOH, MD1	11H	DC1
02H	STX, MD2	12H	DC2
03H	ETX, MD3	13H	DC3
04H	EOT, MD4	14H	DC4
05H	ENQ, MD5	15H	NAK
06H	ACK, MD6	16H	SYN
07H	BEL, MD7	17H	ETB
08H	BS, MD8	18H	CAN
09H	HT	19H	EM
0AH	LF	1AH	SUB
0BH	VT, HOM	1BH	ESC
0CH	FF, CLR	1CH	FS
0DH	CR	1DH	GS
0EH	SO, SLE1	1EH	RS, SF1
0FH	SI, SLE2	1FH	US, SF2